



Agilent U1270 Series Handheld Digital Multimeters

Service Guide



Agilent Technologies

Notices

© Agilent Technologies, Inc. 2010–2014

No part of this manual may be reproduced in any form or by any means (including electronic storage and retrieval or translation into a foreign language) without prior agreement and written consent from Agilent Technologies, Inc. as governed by United States and international copyright laws.

Manual Part Number

U1271-90020

Edition

Eleventh Edition, April 18, 2014

Agilent Technologies, Inc.
5301 Stevens Creek Blvd.
Santa Clara, CA 95051 USA

Warranty

The material contained in this document is provided “as is,” and is subject to change, without notice, in future editions. Further, to the maximum extent permitted by the applicable law, Agilent disclaims all warranties, either express or implied, with regard to this manual and any information contained herein, including but not limited to the implied warranties of merchantability and fitness for a particular purpose. Agilent shall not be liable for errors or for incidental or consequential damages in connection with the furnishing, use, or performance of this document or of any information contained herein. Should Agilent and the user have a separate written agreement with warranty terms covering the material in this document that conflict with these terms, the warranty terms in the separate agreement shall control.

Technology Licenses

The hardware and/or software described in this document are furnished under a license and may be used or copied only in accordance with the terms of such license.

Restricted Rights Legend

U.S. Government Restricted Rights. Software and technical data rights granted to the federal government include only those rights customarily provided to end user customers. Agilent provides this customary commercial license in Software and technical data pursuant to FAR 12.211 (Technical Data) and 12.212 (Computer Software) and, for the Department of Defense, DFARS 252.227-7015 (Technical Data - Commercial Items) and DFARS 227.7202-3 (Rights in Commercial Computer Software or Computer Software Documentation).

Safety Notices

CAUTION







A **CAUTION** notice denotes a hazard. It calls attention to an operating procedure, practice, or the likes of that, if not correctly performed or adhered to, could result in damage to the product or loss of important data. Do not proceed beyond a **CAUTION** notice until the indicated conditions are fully understood and met.

WARNING

A **WARNING** notice denotes a hazard. It calls attention to an operating procedure, practice, or the likes of that, if not correctly performed or adhered to, could result in personal injury or death. Do not proceed beyond a **WARNING** notice until the indicated conditions are fully understood and met.

Safety Symbols

The following symbols on the instrument and in the documentation indicate precautions which must be taken to maintain safe operation of the instrument.

	Direct current (DC)		Caution, risk of electric shock
	Alternating current (AC)		Caution, risk of danger (refer to this manual for specific Warning or Caution information)
	Both direct and alternating current	CAT III 1000 V	Category III 1000 V overvoltage protection
	Earth (ground) terminal	CAT IV 600 V	Category IV 600 V overvoltage protection
	Equipment protected throughout by double insulation or reinforced insulation		

Safety Considerations

Read the information below before using this multimeter. The descriptions and instructions in this manual apply to the Agilent U1271A, U1272A, U1273A, and U1273AX Handheld Digital Multimeters (hereafter referred to as the multimeter). The U1273A and U1272A models appear in all illustrations.

CAUTION

- Disconnect circuit power and discharge all high-voltage capacitors before measuring resistance, continuity, diodes, or capacitance.
- Use the proper terminals, function, and range for your measurements.
- This device is for use at altitudes of up to 3000 m.
- Never measure voltage when current measurement is selected.
- Always use the specified battery type. The power for the meter is supplied with four AAA 1.5 V batteries. Observe the correct polarity markings before you insert the batteries to ensure proper insertion of the batteries in the meter.
- To avoid damage to the instrument from battery leakage:
 - Always remove dead batteries immediately.
 - Always remove the batteries and store them separately if the instrument is not going to be used or is being stored for a long period of time.

WARNING

- **Do not use the multimeter if it is damaged. Before you use the multimeter, inspect the case. Look for cracks or missing plastic. Pay particular attention to the insulation surrounding the connectors.**
- **Inspect the test leads for damaged insulation or exposed metal. Check the test leads for continuity. Replace damaged test leads before you use the multimeter.**
- **Do not operate the multimeter around explosive gas, vapor, or wet environments.**

WARNING

- Do not apply more than the rated voltage (as marked on the multimeter) between terminals, or between the terminal and earth ground. Before use, verify the multimeter's operation by measuring a known voltage.
 - Never use the multimeter in wet conditions or when there is water on the surface. If the multimeter is wet, ensure that the multimeter is dried only by trained personnel.
 - When measuring current, turn off the circuit power before connecting the multimeter in the circuit. Remember to place the multimeter in series with the circuit.
 - Apply caution when working above 60 V_{DC}, 30 V_{AC} (RMS), or 42.4 V_{PEAK}. Such voltages pose a shock hazard.
 - Be aware of the presence of hazardous voltage before using the Low Pass Filter (LPF) function for voltage measurement. Voltages measured are usually greater than what are indicated on the multimeter as the voltages with higher frequencies have been filtered through the LPF function.
 - Do not use the Z_{LOW} (low input impedance) function (U1272A, U1273A, and U1273AX only) to measure voltages in circuits that could be damaged by this function's low input impedance of 2 kΩ.
 - When using the probes, keep your fingers behind the finger guards on the probes.
 - Connect the common test lead before you connect the live test lead. When you disconnect the leads, disconnect the live test lead first.
 - Remove the test leads from the multimeter before you open the battery cover. Do not operate the multimeter with the battery cover or portions of the cover removed or loosened. When servicing the multimeter, use only the specified replacement parts.
 - To avoid false readings, which may lead to possible electric shock or personal injury, replace the battery as soon as the low battery indicator appears and flashes.
-

Environmental Conditions

This instrument is designed for indoor use and in an area with low condensation. The table below shows the general environmental requirements for this instrument.





Environmental conditions	Requirements
Temperature	<ul style="list-style-type: none">• Operating condition<ul style="list-style-type: none">• U1271A/U1272A/U1273A: –20 °C to 55 °C• U1273AX: –40 °C to 55 °C (using Lithium batteries)• Storage condition<ul style="list-style-type: none">• –40°C to 70 °C
Humidity	<ul style="list-style-type: none">• Operating condition<ul style="list-style-type: none">• Maximum: 80% RH at 40 °C (non-condensing)• Minimum: 50% RH at 40 °C (non-condensing)• Storage condition<ul style="list-style-type: none">• Up to 95% RH at 40 °C (non-condensing)
Altitude	Up to 3000 m
Pollution degree	Pollution degree II

NOTE

The U1270 Series Handheld Digital Multimeters comply with the following safety and EMC requirements:

- **Safety**
 - EN/IEC 61010-1:2001
 - ANSI/UL 61010-1:2004
 - CAN/CSA-C22.2 No. 61010-1-04
- **EMC**
 - IEC61326-1:2005/EN61326-1:2006
 - Canada: ICES/NMB-001: Issue 4, June 2006
 - Australia/New Zealand: AS/NZS CISPR 11:2004

Regulatory Markings

 <p>ISM 1-A</p>	<p>The CE mark is a registered trademark of the European Community. This CE mark shows that the product complies with all the relevant European Legal Directives.</p>	 <p>N10149</p>	<p>The C-tick mark is a registered trademark of the Spectrum Management Agency of Australia. This signifies compliance with the Australia EMC Framework regulations under the terms of the Radio Communication Act of 1992.</p>
<p>ICES/NMB-001</p>	<p>ICES/NMB-001 indicates that this ISM device complies with the Canadian ICES-001. Cet appareil ISM est conforme a la norme NMB-001 du Canada.</p>		<p>This instrument complies with the WEEE Directive (2002/96/EC) marking requirement. This affixed product label indicates that you must not discard this electrical or electronic product in domestic household waste.</p>
 <p>US</p>	<p>The CSA mark is a registered trademark of the Canadian Standards Association.</p>		<p>This symbol indicates the time period during which no hazardous or toxic substance elements are expected to leak or deteriorate during normal use. Forty years is the expected useful life of the product.</p>

Waste Electrical and Electronic Equipment (WEEE) Directive 2002/96/EC

This instrument complies with the WEEE Directive (2002/96/EC) marking requirement. This affixed product label indicates that you must not discard this electrical or electronic product in domestic household waste.

Product Category:

With reference to the equipment types in the WEEE directive Annex 1, this instrument is classified as a “Monitoring and Control Instrument” product.

The affixed product label is as shown below.



Do not dispose in domestic household waste.

To return this unwanted instrument, contact your nearest Agilent Service Centre, or visit

www.agilent.com/environment/product

for more information.

Declaration of Conformity (DoC)

The Declaration of Conformity (DoC) for this instrument is available on the Agilent Web site. You can search the DoC by its product model or description at the Web address below.

<http://regulations.corporate.agilent.com/DoC/search.htm>

NOTE

If you are unable to search for the respective DoC, please contact your local Agilent representative.

THIS PAGE HAS BEEN INTENTIONALLY LEFT BLANK.

Table of Contents

1 Calibration Procedures

Calibration Overview	18
Closed-case calibration	18
Agilent calibration services	18
Calibration interval	19
Adjustment is recommended	19
Recommended Test Equipment	20
Basic Operating Test	22
Backlight test (U1271A/U1272A only)	22
Display test	22
Current terminal input test	23
Calibration Process	25
Test Considerations	26
Performance Verification Tests	27
Calibration Security	37
Unsecuring the Instrument for Calibration	38
To unsecure the instrument from the front panel	38
To change the calibration security code	39
To reset the calibration security code to its factory default	40
Using the Front Panel for Adjustments	42
Adjustment considerations	42
Valid adjustment input values	43
Adjustment procedure	47
Exiting the adjustment mode	48
Calibration Count	49
Calibration Error Codes	50

2 Service and Maintenance

Troubleshooting	52
Checking the Fuse	53
Fuse Replacement	57
Returning the Instrument for Service	61
Replaceable Parts	62
To order replaceable parts	62
Types of Service Available	63
Extended service contracts	63
Obtaining Repair Service (Worldwide)	64

List of Figures

Figure 1-1	U1273A/U1273AX OLED display screen	22
Figure 1-2	U1271A/U1272A LCD screen	23
Figure 1-3	Input warning display (A terminal)	23
Figure 1-4	Input warning display (μA mA terminal)	24
Figure 1-5	Unsecuring the instrument	38
Figure 1-6	Changing the calibration security code	39
Figure 1-7	Resetting the calibration security code	40
Figure 1-8	Reference value display	47
Figure 2-1	Testing Fuse 1	55
Figure 2-2	Testing Fuse 2	56
Figure 2-3	Replacing Fuse 1	58
Figure 2-4	Replacing Fuse 2	59
Figure 2-5	Positions of Fuse 1 and Fuse 2	60

THIS PAGE HAS BEEN INTENTIONALLY LEFT BLANK.

List of Tables

Table 1-1	Recommended test equipment	20
Table 1-2	Performance verification tests	28
Table 1-3	Adjustment input values	43
Table 1-4	Calibration error codes	50
Table 2-1	Operating checklist	52
Table 2-2	Fuse displayed readings	54

THIS PAGE HAS BEEN INTENTIONALLY LEFT BLANK.



1 Calibration Procedures

Calibration Overview	18
Closed-case calibration	18
Agilent calibration services	18
Calibration interval	19
Adjustment is recommended	19
Recommended Test Equipment	20
Basic Operating Test	22
Backlight test (U1271A/U1272A only)	22
Display test	22
Current terminal input test	23
Calibration Process	25
Test Considerations	26
Performance Verification Tests	27
Calibration Security	37
Unsecuring the Instrument for Calibration	38
To unsecure the instrument from the front panel	38
To change the calibration security code	39
To reset the calibration security code to its factory default	40
Using the Front Panel for Adjustments	42
Adjustment considerations	42
Valid adjustment input values	43
Adjustment procedure	47
Exiting the adjustment mode	48
Calibration Count	49
Calibration Error Codes	50

This chapter helps you to verify the instrument performance and to make adjustments where necessary.



Calibration Overview

This manual contains procedures to verify the U1270 Series handheld digital multimeters performance and to perform adjustments (calibration). The performance test procedures allow you to verify that the instrument is operating within its published specifications. The adjustment procedures ensure that the instrument remains within its specifications until the next calibration.

NOTE

Ensure that you have read the “[Test Considerations](#)” on page 26 before calibrating the instrument.

Closed-case calibration

The instrument features closed-case electronic calibration. In other words, no internal mechanical adjustments are required. The instrument calculates correction factors based upon the input reference value you set. The new correction factors are stored in the nonvolatile memory until the next calibration adjustment is performed. The nonvolatile EEPROM calibration memory is retained even when the power is switched off.

Agilent calibration services

When your instrument is due for calibration, contact your local Agilent Service Center to enquire about recalibration services.

Calibration interval

A 1-year interval is adequate for most applications. Accuracy specifications are warranted only if adjustment is made at regular calibration intervals. Accuracy specifications are not warranted beyond the 1-year calibration interval. Agilent does not recommend extending calibration intervals beyond 2 years for any application.

Adjustment is recommended

Specifications are only guaranteed within the period stated from the last adjustment. Agilent recommends that re-adjustment should be performed during the calibration process for best performance. This will ensure that the instrument will remain within the specifications for the next calibration interval.

This criterion for the re-adjustment provides the best long-term stability. Performance data are measured during the “[Performance Verification Tests](#)” but this does not guarantee that the instrument will remain within these limits unless the adjustments are performed.

Refer to the “[Calibration Count](#)” on page 49 and verify that all the adjustments have been performed.

Recommended Test Equipment

The test equipment recommended for the performance verification and adjustment procedures are listed below (Table 1-1). If the exact instrument is not available, substitute with another calibration standard of equivalent accuracy.

A suggested alternative method is to use the Agilent 3458A 8½ Digit Digital Multimeter to measure less accurate but stable sources. The output value measured from the source can be entered into the instrument as the target calibration value.

Table 1-1 Recommended test equipment

Application	Recommended equipment	Recommended accuracy requirements
DC voltage	Fluke 5520A	<20% of the U1270 Series accuracy specification
DC current	Fluke 5520A	<20% of the U1270 Series accuracy specification
Resistance	Fluke 5520A	<20% of the U1270 Series accuracy specification
AC voltage	Fluke 5520A	<20% of the U1270 Series accuracy specification
AC current	Fluke 5520A	<20% of the U1270 Series accuracy specification
Frequency	Fluke 5520A	<20% of the U1270 Series accuracy specification
Capacitance	Fluke 5520A	<20% of the U1270 Series accuracy specification
Duty cycle	Fluke 5520A	<20% of the U1270 Series accuracy specification
Diode	Fluke 5520A	<20% of the U1270 Series accuracy specification

Table 1-1 Recommended test equipment (continued)

Application	Recommended equipment	Recommended accuracy requirements
Temperature	Fluke 5520A	<20% of the U1270 Series accuracy specification
Short	Shorting plug — a dual banana plug with a copper wire shorting the two terminals	
Z _{low}	Agilent U1252B	—

Basic Operating Test

The tests listed below are used to test the basic operability of the instrument. Repair is required if the instrument fails any of these tests.

- “Backlight test (U1271A/U1272A only)”
- “Display test”
- “Current terminal input test”

Backlight test (U1271A/U1272A only)

Press and hold the  key while turning the rotary switch to any other position (OFF to ON). Check that the multimeter’s backlight is turned on. Press any key to exit this mode.

Display test

Press and hold the  key while turning the rotary switch to any other position (OFF to ON).

For U1273A/U1273AX models:

Check that all the OLED pixels are lit. Verify that there are no dead pixels. Press any key to exit this mode.

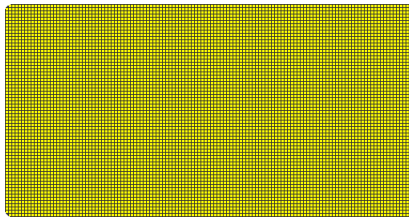

Figure 1-1 U1273A/U1273AX OLED display screen

For U1271A/U1272A models:

Check that all the annunciators are displayed on the LCD screen. Compare the display with the example shown in [Figure 1-2](#). Press any key to exit this mode.

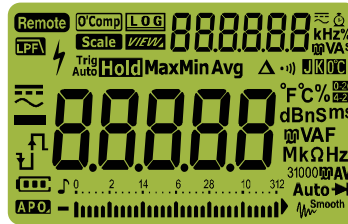

Figure 1-2 U1271A/U1272A LCD screen

Current terminal input test

This test determines if the input warnings of the current terminals are functioning properly.

Input warning test (A terminal)

The multimeter sounds a continuous alert beep when the test lead is inserted into the **A** terminal but the rotary switch is not set to the $\tilde{\sim}$ function.

The multimeter displays an input warning error ([Figure 1-3](#)).

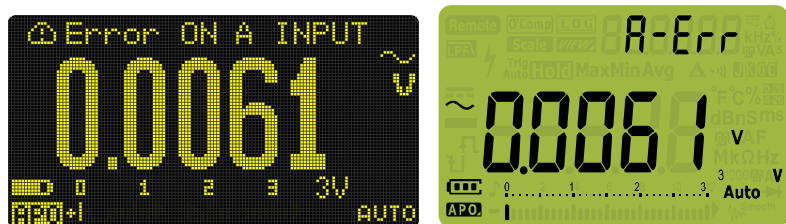

Figure 1-3 Input warning display (A terminal)

The alert beep tone will continue to beep until the test lead is removed from the **A** terminal or until the rotary switch is set to the $\tilde{\mu}\tilde{A}$ function.

NOTE

Before conducting this test, ensure that the beep function is not disabled in the multimeter's setup.

Input warning test (μA mA terminal)

The multimeter sounds a continuous alert beep when the test lead is inserted into the μA mA terminal but the rotary switch is not set to the $\tilde{\mu}\tilde{A}$ or $\tilde{\text{mA}}\tilde{\text{A}}$ function.

The multimeter displays an input warning error (Figure 1-4).

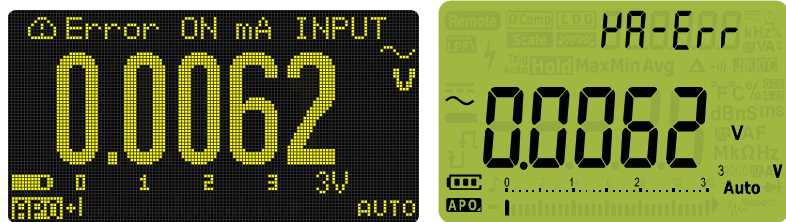

Figure 1-4 Input warning display (μA mA terminal)

The alert beep tone will continue to beep until the test lead is removed from the μA mA terminal or until the rotary switch is set to the $\tilde{\mu}\tilde{A}$ or $\tilde{\text{mA}}\tilde{\text{A}}$ function.

NOTE

Before conducting this test, ensure that the beep function is not disabled in the multimeter's setup.

Calibration Process

- 1 Prior to performing the verification tests, see the “[Test Considerations](#)” on page 26.
- 2 Perform the verification tests to characterize the instrument; see “[Performance Verification Tests](#)” on page 27.
- 3 Unsecure the instrument for calibration; see “[Calibration Security](#)” on page 37.
- 4 Prior to performing the adjustments, see the “[Adjustment considerations](#)” on page 42.
- 5 Perform the adjustment procedure; see “[Adjustment procedure](#)” on page 47.
- 6 Secure the instrument against unauthorized calibration; see “[Exiting the adjustment mode](#)” on page 48. Ensure that the instrument has quit the adjustment mode and is turned off.
- 7 Record the new security code and calibration count in the instrument's maintenance records.

Test Considerations

For optimum performance, all procedures should comply with the following recommendations:

- The performance verification test or adjustment should be performed under laboratory conditions where the ambient temperature can be controlled.
- The instrument should be put under the laboratory environment for at least 1 hour.
- Ensure that the calibration ambient temperature is stable and is between 18 °C and 28 °C. Ideally the calibration should be performed at 23 °C ± 1 °C.
- Ensure that the ambient relative humidity is less than 80%.
- Allow a warm-up period of 3 minutes.
- Use a shielded twisted pair of PTFE-insulated cables to reduce settling and noise errors. Keep the input cables as short as possible. Long test leads can also act as antennas which may pick up AC signals.
- Connect the input cable shields to earth ground.

Performance Verification Tests

Use the performance verification tests to verify the measurement performance of the instrument. The performance verification tests use the instrument's specifications listed in the *U1271A/U1272A User's Guide* and the *U1273A/U1273AX User's Guide* (available for download at www.agilent.com/find/hhTechLib).

The performance verification tests are recommended as acceptance tests when you first receive the instrument. The acceptance test results should be compared against the 1 year test limits. After acceptance, you should repeat the performance verification tests at every calibration interval.

If the instrument fails the performance verification tests, adjustment or repair is required.

NOTE

Ensure that you have read the “[Test Considerations](#)” on page 26 before running the performance verification tests.

1 Calibration Procedures

Performance Verification Tests

Table 1-2 Performance verification tests

Step	Test function	Range	5520 output	Error from nominal 1 year	
				U1271A	U1272A/ U1273A/U1273AX
1 ^[1]	Qik-V Turn the rotary switch to the $\tilde{\sim}_{Qik-V}$ position.	1000 V	1000 V 1000 V, 70 Hz	±20 V ±250 V	- -
	Z_{Low} Turn the rotary switch to the $\tilde{\sim}_{Z_{Low}V}$ position.	1000 V	3 V	-	±2.0 V
	NOTE: First connect the COM and Ω terminals of the U1252B (or equivalent) to the COM and V terminals of the U1272A/U1273A/U1273AX, then turn the U1272A/U1273A/U1273AX rotary switch to the $\tilde{\sim}_{Z_{Low}V}$ position before proceeding with the following Z_{Low} functional test.				
	U1252B input				
	Z_{Low} Turn the rotary switch to the $\tilde{\sim}_{Z_{Low}V}$ position.	1000 V	1.67 k Ω	-	±0.167 k Ω
[1] Functional test only.					

Table 1-2 Performance verification tests (continued)

Step	Test function	Range	5520 output	Error from nominal 1 year	
				U1271A	U1272A/ U1273A/U1273AX
2	ACV Turn the rotary switch to the  position.	3 V	3 V, 20 Hz	-	±0.0325 V
			3 V, 45 Hz	±0.0230 V	±0.0200 V
			3 V, 65 Hz	±0.0230 V	±0.0200 V
			3 V, 1 kHz	±0.0325 V	±0.0325 V
			3 V, 5 kHz	±0.0625 V	±0.0475 V
			3 V, 20 kHz	±0.0640 V	±0.0640 V
			2.7 V, 100 kHz	-	±0.0985 V
			30 V	-	±0.325 V
		30 V	30 V, 20 Hz	-	±0.325 V
			30 V, 45 Hz	±0.230 V	±0.200 V
			30 V, 65 Hz	±0.230 V	±0.200 V
			30 V, 1 kHz	±0.325 V	±0.325 V
			30 V, 5 kHz	±0.0625 V	±0.475 V
			30 V, 20 kHz	±0.640 V	±0.640 V
			27 V, 100 kHz	-	±0.985 V
		300 V	300 V, 45 Hz	±2.30 V	±2.00 V
			300 V, 65 Hz	±2.30 V	±2.00 V
			300 V, 1 kHz	±3.25 V	±3.25 V
			300 V, 5 kHz	±6.25 V	±4.75 V
			270 V, 20 kHz	-	±5.80 V
		1000 V	1000 V, 45 Hz	±9.0 V	±8.0 V
			1000 V, 65 Hz	±9.0 V	±8.0 V
			1000 V, 1 kHz	±12.5 V	±12.5 V
			1000 V, 5 kHz	-	±17.5 V

1 Calibration Procedures

Performance Verification Tests

Table 1-2 Performance verification tests (continued)









Step	Test function	Range	5520 output	Error from nominal 1 year	
				U1271A	U1272A/ U1273A/U1273AX
	LPF While the rotary switch is in the  position, press the  key once.	3 V	3 V, 20 Hz 3 V, 45 Hz 3 V, 65 Hz 2.7 V, 430 Hz	- ±0.0230 V ±0.0230 V ±0.1375 V	±0.0325 V ±0.0200 V ±0.0200 V ±0.1375 V
3	Frequency While the rotary switch is in the  position, press the  key once.	9.9999 kHz	1.0000 kHz, 0.096 V	±0.0005 kHz	±0.0005 kHz
4	Duty cycle While the rotary switch is in the  position, press the  key twice.	99.99%	50%, 100 Hz, 3 Vpp square wave	±0.3%	±0.3%
5	ACmV Turn the rotary switch to the  position.	30 mV	30 mV, 20 Hz	-	±0.235 mV
			30 mV, 45 Hz	-	±0.200 mV
			30 mV, 65 Hz	-	±0.200 mV
			30 mV, 1 kHz	-	±0.235 mV
			30 mV, 5 kHz	-	±0.325 mV
			30 mV, 20 kHz	-	±0.340 mV
			30 mV, 100 kHz	-	±1.090 mV
		300 mV	300 mV, 20 Hz	-	±2.35 mV
			300 mV, 45 Hz	±2.30 mV	±2.00 mV
			300 mV, 65 Hz	±2.30 mV	±2.00 mV
			300 mV, 1 kHz	±3.25 mV	±2.35 mV
			300 mV, 5 kHz	±6.25 mV	±3.25 mV
			300 mV, 20 kHz	±6.40 mV	±3.40 mV
			300 mV, 100 kHz	-	±10.90 mV

Table 1-2 Performance verification tests (continued)

Step	Test function	Range	5520 output	Error from nominal 1 year	
				U1271A	U1272A/ U1273A/U1273AX
6	DCV Turn the rotary switch to the $\overline{\nabla}$ / $\overline{\nabla}$ position.	3 V	3 V	±0.0020 V	±0.0020 V
		30 V	30 V	±0.017 V	±0.017 V
		300 V	300 V	±0.17 V	±0.17 V
		1000 V	1000 V	±0.7 V	±0.7 V
7	AC+DCV Turn the rotary switch to the $\overline{\nabla}$ position, and press the  key twice.	3 V	3 V, 20 Hz	-	±0.0360 V
			3 V, 45 Hz	-	±0.0235 V
			3 V, 65 Hz	-	±0.0235 V
			3 V, 1 kHz	-	±0.0360 V
			3 V, 5 kHz	-	±0.0510 V
			3 V, 20 kHz	-	±0.0675 V
			2.7 V, 100 kHz	-	±0.1017 V
		30 V	30 V, 20 Hz	-	±0.360 V
			30 V, 45 Hz	-	±0.235 V
			30 V, 65 Hz	-	±0.235 V
			30 V, 1 kHz	-	±0.360 V
			30 V, 5 kHz	-	±0.510 V
			30 V, 20 kHz	-	±0.675 V
			27 V, 100 kHz	-	±1.017 V
		300 V	300 V, 45 Hz	-	±2.35 V
			300 V, 65 Hz	-	±2.35 V
			300 V, 1 kHz	-	±3.60 V
			300 V, 5 kHz	-	±5.10 V
			270 V, 20 kHz	-	±6.12 V

1 Calibration Procedures

Performance Verification Tests

Table 1-2 Performance verification tests (continued)







Step	Test function	Range	5520 output	Error from nominal 1 year	
				U1271A	U1272A/ U1273A/U1273AX
	AC+DCV Turn the rotary switch to the \tilde{V} position, and press the  key twice.	1000 V	1000 V, 45 Hz	-	±9.5 V
			1000 V, 65 Hz	-	±9.5 V
			1000 V, 1 kHz	-	±14.0 V
			1000 V, 5 kHz	-	±19.0 V
8	DCmV ^[2] Turn the rotary switch to the $\overset{\sim}{mV}$ / $\overset{\sim}{mV}$ position.	30 mV	30 mV	-	±0.035 mV
			-30 mV	-	±0.035 mV
		300 mV	300 mV	±0.20 mV	±0.20 mV
			-300 mV	±0.20 mV	±0.20 mV
[2] The accuracy is specified after the Null function is used to subtract the thermal effect (by shorting the test leads) before measuring the signal.					
9	AC+DCmV Turn the rotary switch to the $\overset{\sim}{mV}$ position, and press the  key twice.	30 mV	30 mV, 20 Hz	-	±0.285 mV
			30 mV, 45 Hz	-	±0.250 mV
			30 mV, 65 Hz	-	±0.250 mV
			30 mV, 1 kHz	-	±0.285 mV
			30 mV, 5 kHz	-	±0.375 mV
			30 mV, 20 kHz	-	±0.390 mV
			30 mV, 100 kHz	-	±1.140 mV

Table 1-2 Performance verification tests (continued)

Step	Test function	Range	5520 output	Error from nominal 1 year	
				U1271A	U1272A/ U1273A/U1273AX
	AC+DCmV Turn the rotary switch to the  position, and press the  key twice.	300 mV	300 mV, 20 Hz	-	±2.70 mV
300 mV, 45 Hz			-	±2.35 mV	
300 mV, 65 Hz			-	±2.35 mV	
300 mV, 1 kHz			-	±2.70 mV	
300 mV, 5 kHz			-	±3.60 mV	
300 mV, 20 kHz			-	±3.75 mV	
300 mV, 100 kHz			-	±11.25 mV	
10 Resistance Turn the rotary switch to the  position.			30 Ω ^{[3][5]}	30 Ω	-
	300 Ω ^{[3][5]}	300 Ω	±0.65 Ω	±0.65 Ω	
	3 kΩ ^{[3][5]}	3 kΩ	±0.0065 kΩ	±0.0065 kΩ	
	30 kΩ ^[5]	30 kΩ	±0.065 kΩ	±0.065 kΩ	
	300 kΩ	300 kΩ	±0.65 kΩ	±0.65 kΩ	
	3 MΩ	3 MΩ	±0.0185 MΩ	±0.0185 MΩ	
	30 MΩ ^[4]	30 MΩ	±0.365 MΩ	±0.365 MΩ	
	100 MΩ ^[4]	100 MΩ	±2.10 MΩ	-	
	300 MΩ ^[4]	120 MΩ	-	±9.70 MΩ	
<p>[3] The accuracy of the 30 Ω to 3 kΩ range is specified after the Null function is used to subtract the test lead resistance and thermal effect (by shorting the test leads). Apply a 0 Ω calibrator output and allow the multimeter to settle before pressing the  key.</p> <p>[4] The RH is specified for <60%.</p> <p>[5] With a 2-wire connection and compensation enabled at calibrator.</p>					
11	Diode Turn the rotary switch to the  position.	3 V	3 V	0.0155 V	0.0155 V

1 Calibration Procedures

Performance Verification Tests

Table 1-2 Performance verification tests (continued)







Step	Test function	Range	5520 output	Error from nominal 1 year	
				U1271A	U1272A/ U1273A/U1273AX
12	Capacitance ^[6] Turn the rotary switch to the  position.	10 nF	10 nF	±0.015 nF	±0.015 nF
		100 nF	100 nF	±1.02 nF	±1.02 nF
		1000 nF	1000 nF	±10.2 nF	±10.2 nF
		10 μF	10 μF	±0.102 μF	±0.102 μF
		100 μF	100 μF	±1.02 μF	±1.02 μF
		1000 μF	1000 μF	±10.2 μF	±10.2 μF
		10 mF	10 mF	±0.102 mF	±0.102 mF
<p>[6] The accuracy for all ranges is specified based on a film capacitor or better, and after the Null function is used to subtract the residual values (by opening the test leads).</p>					
13	Temperature ^[7] While the rotary switch is in the  position, press the  key once.	-200 °C to 1372 °C	-200 °C	±3.0 °C	±3.0 °C
			0 °C	±1.0 °C	±1.0 °C
			1372 °C	±14.7 °C	±14.7 °C
<p>[7] Ensure that the ambient temperature is stable within ±1 °C. Ensure that the multimeter is placed in a controlled environment for at least 1 hour before you proceed to ensure that the multimeter's internal reference junction sensor and input terminal are stabilized at the same environment. Keep the multimeter away from any ventilation exit.</p> <p>Differences in ambient compensation between the calibrator and multimeter may cause some deviations shown between the readings of the calibrator and multimeter. Placing the multimeter close to the output terminal of the calibrator will help reduce this deviation.</p> <p>Keep the thermocouple test lead as close to the multimeter as possible.</p> <p>Do not touch the thermocouple test lead after connecting it to the calibrator. Allow the connection to stabilize for at least another 15 minutes before performing the measurement.</p>					
14	DCμA Turn the rotary switch to the  position.	300 μA	300 μA	±0.65 μA	±0.65 μA
		3000 μA	3000 μA	±6.5 μA	±6.5 μA

Table 1-2 Performance verification tests (continued)



Step	Test function	Range	5520 output	Error from nominal 1 year	
				U1271A	U1272A/ U1273A/U1273AX
15	ACμA While the rotary switch is in the μA position, press the  key once.	300 μA	300 μA , 20 Hz	-	$\pm 2.95 \mu\text{A}$
			300 μA , 45 Hz	$\pm 2.95 \mu\text{A}$	$\pm 2.05 \mu\text{A}$
			300 μA , 65 Hz	$\pm 2.95 \mu\text{A}$	$\pm 2.05 \mu\text{A}$
			300 μA , 1 kHz	$\pm 2.95 \mu\text{A}$	$\pm 2.95 \mu\text{A}$
		3000 μA	3000 μA , 20 Hz	-	$\pm 29.5 \mu\text{A}$
			3000 μA , 45 Hz	$\pm 29.5 \mu\text{A}$	$\pm 20.5 \mu\text{A}$
			3000 μA , 65 Hz	$\pm 29.5 \mu\text{A}$	$\pm 20.5 \mu\text{A}$
			3000 μA , 1 kHz	$\pm 29.5 \mu\text{A}$	$\pm 29.5 \mu\text{A}$
16	DCmA Turn the rotary switch to the mA position.	30 mA	30 mA	$\pm 0.065 \text{ mA}$	$\pm 0.065 \text{ mA}$
		300 mA	300 mA	$\pm 0.65 \text{ mA}$	$\pm 0.65 \text{ mA}$
17	ACmA While the rotary switch is in the mA position, press the  key once.	30 mA	30 mA, 20 Hz	-	$\pm 0.295 \text{ mA}$
			30 mA, 45 Hz	$\pm 0.295 \text{ mA}$	$\pm 0.205 \text{ mA}$
			30 mA, 65 Hz	$\pm 0.295 \text{ mA}$	$\pm 0.205 \text{ mA}$
			30 mA, 1 kHz	$\pm 0.295 \text{ mA}$	$\pm 0.295 \text{ mA}$
		300 mA	300 mA, 20 Hz	-	$\pm 2.95 \text{ mA}$
			300 mA, 45 Hz	$\pm 2.95 \text{ mA}$	$\pm 2.05 \text{ mA}$
			300 mA, 65 Hz	$\pm 2.95 \text{ mA}$	$\pm 2.05 \text{ mA}$
			300 mA, 1 kHz	$\pm 2.95 \text{ mA}$	$\pm 2.95 \text{ mA}$
18	DCA^[8] Turn the rotary switch to the mA position.	3 A	3 A	$\pm 0.0100 \text{ A}$	$\pm 0.0100 \text{ A}$
		10 A	10 A	$\pm 0.04 \text{ A}$	$\pm 0.04 \text{ A}$

[8] **CAUTION:** Connect the calibrator to the multimeter's **A** and **COM** terminals before applying the 3 A and 10 A input.

1 Calibration Procedures

Performance Verification Tests

Table 1-2 Performance verification tests (continued)

Step	Test function	Range	5520 output	Error from nominal 1 year	
				U1271A	U1272A/ U1273A/U1273AX
19	ACA While the rotary switch is in the  position, press the  key once.	3 A	3 A, 45 Hz	±0.0325 A	±0.0265 A
			3 A, 65 Hz	±0.0325 A	±0.0265 A
			3 A, 1 kHz	±0.0325 A	±0.0325 A
		10 A	10 A, 45 Hz	±0.125 A	±0.105 A
			10 A, 65 Hz	±0.125 A	±0.105 A
			10 A, 1 kHz	±0.125 A	±0.125 A

Calibration Security

The calibration security code prevents accidental or unauthorized adjustments to the instrument. When you first receive your instrument, it is secured. Before you can adjust the instrument, you must unsecure it by entering the correct security code (see [“Unsecuring the Instrument for Calibration”](#) on page 38).

NOTE

The security code can only be changed after the instrument has been unsecured. You can unsecure the instrument from its front panel.

The security code is set to “1234” when the instrument is shipped from the factory. The security code is stored in nonvolatile memory, and does not change when power has been turned off.

The security code may contain up to four numeric characters.

1 Calibration Procedures

Unsecuring the Instrument for Calibration

Unsecuring the Instrument for Calibration



Before you can adjust the instrument, you must unsecure it by entering the correct security code.

The default security code is set to 1234.

NOTE

If you forget your security code, see [“To reset the calibration security code to its factory default”](#) on page 40.

To unsecure the instrument from the front panel

- 1 Power-on the instrument and press the  and  keys simultaneously for more than 1 second.

The calibration security code entry is shown on the display.

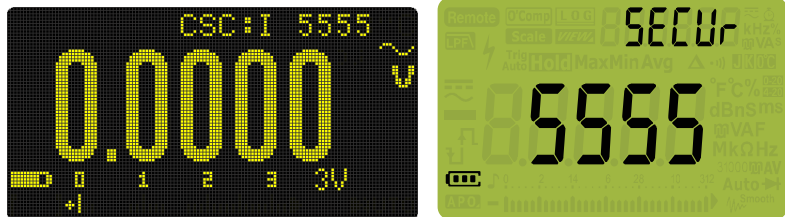







Figure 1-5 Unsecuring the instrument

- 2 Key in the default security code if you are unsecuring your instrument for the first time.
 - Press  or  to move the cursor to the right or to the left.
 - Press  or  to increment or decrement the digit.
- 3 Press  when you are done.

If the correct security code is entered, **PASS** is shown briefly, after which the instrument will enter the adjustment mode.

If the incorrect security code is entered, an error code will appear briefly, after which the instrument will prompt you for the security code again.

To change the calibration security code

- 1 After the instrument has been unsecured, press  for more than 1 second.
- 2 The factory default calibration security code “1234” is shown on the display if you are changing the calibration security code for the first time.

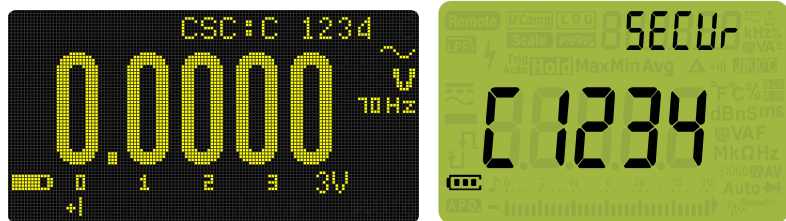







Figure 1-6 Changing the calibration security code

- 3 Set your new calibration security code.
 - Press  or  to move the cursor to the right or to the left.
 - Press  or  to increment or decrement the digit.
- 4 Press  to save the new calibration security code.

If the new calibration security code has been successfully stored, the display will show **PASS**. Record down your new calibration security code and store it in a safe location.



To reset the calibration security code to its factory default

If you have forgotten the correct calibration security code, you may follow the steps below to reset the calibration security code to the factory default code (1234).



NOTE

If you do not have a record (or have lost the record) of the security code, first try the factory default code, "1234".

1 Before you begin, note down the last four digits of the instrument's serial number (located at the bottom of the rear panel).

2 Power-on the instrument and press the  and  keys simultaneously for more than 1 second.

The calibration security code entry is shown on the display.

3 Press  (for U1273A/U1273AX) or  (for U1271A/U1272A) for more than 1 second.

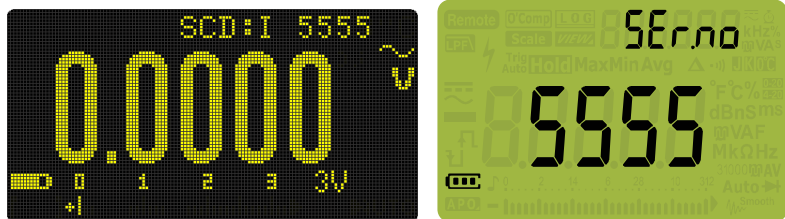







Figure 1-7 Resetting the calibration security code

4 Set the code to the same as the last four digits of the instrument's serial number.

- Press  or  to move the cursor to the right or to the left.
- Press  or  to increment or decrement the digit.

5 Press  to confirm the entry.

If the four digits entered are correct, the display will show **PASS**. The calibration security code is now set to its factory default code, 1234.

If the incorrect security code is entered, an error code will appear briefly, after which the instrument will prompt you for the security code again.

If you want to enter a new security code, see [“To change the calibration security code”](#) on page 39. Ensure that you record down the new security code.

Using the Front Panel for Adjustments

This section describes the procedures to perform adjustments from the front panel.

To unsecure the instrument, see [“To unsecure the instrument from the front panel”](#) on page 38. Once unsecured, the reference value will be indicated on the display.

Adjustment considerations

NOTE

After each adjustment, the display shows **PASS**. If the calibration fails, the instrument sounds a beep, and an error number is shown on the display. Calibration error messages are described in [“Calibration Error Codes”](#) on page 50.

- 1 Allow the instrument to warm up and stabilize for 3 minutes before performing the adjustments.
- 2 Ensure that during the adjustments, the low battery indicator does not appear. If the low battery indicator appears, replace the batteries as soon as possible to avoid false readings.
- 3 Consider the thermal effects as you are connecting the test leads to the calibrator and multimeter. It is recommended to wait for 1 minute before you begin the calibration after connecting the test leads.
- 4 Before proceeding with the ambient temperature adjustment, be sure to turn on the multimeter for at least 1 hour with the K-type thermocouple connected.

CAUTION

Never turn off the multimeter during an adjustment. This may delete the calibration memory for the present function.

Valid adjustment input values

Adjustment can be accomplished using the following input values below.

Table 1-3 Adjustment input values

Test function	Step	Reference value	Valid reference input
DCmV	SHORT	SHORT	SHORT V/COM terminals
	30 mV	30.000 mV	0.9 to 1.1 × Reference value
	300 mV	300.00 mV	0.9 to 1.1 × Reference value
ACmV		3.000 mV (70 Hz)	0.9 to 1.1 × Reference value
	30 mV	30.000 mV (70 Hz)	0.9 to 1.1 × Reference value
		30.000 mV (30 kHz)	0.9 to 1.1 × Reference value
	300 mV	30.00 mV (70 Hz)	0.9 to 1.1 × Reference value
		300.00 mV (70 Hz)	0.9 to 1.1 × Reference value
		300.00 mV (30 kHz)	0.9 to 1.1 × Reference value
DCV	SHORT	SHORT	SHORT V/COM terminals
	3 V	3.0000 V	0.9 to 1.1 × Reference value
	30 V	30.000 V	0.9 to 1.1 × Reference value
	300 V	300.00 V	0.9 to 1.1 × Reference value
	1000 V	1000.0 V	0.9 to 1.1 × Reference value

1 Calibration Procedures

Using the Front Panel for Adjustments

Table 1-3 Adjustment input values (continued)

Test function	Step	Reference value	Valid reference input
ACV	3 V	0.3000 V (70 Hz)	0.9 to 1.1 × Reference value
		3.0000 V (70 Hz)	0.9 to 1.1 × Reference value
		3.0000 V(3 kHz)	0.9 to 1.1 × Reference value
	30 V	3.000 V (70 Hz)	0.9 to 1.1 × Reference value
		30.000 V (70 Hz)	0.9 to 1.1 × Reference value
		30.000 V(3 kHz)	0.9 to 1.1 × Reference value
	300 V	30.00 V (70 Hz)	0.9 to 1.1 × Reference value
		300.00 V (70 Hz)	0.9 to 1.1 × Reference value
		300.00 V (3 kHz)	0.9 to 1.1 × Reference value
	1000 V	30.0 V (70 Hz)	0.9 to 1.1 × Reference value
		300.0 V (70 Hz)	0.9 to 1.1 × Reference value
		300.0 V (3 kHz)	0.9 to 1.1 × Reference value
DC μ A	OPEN	OPEN	OPEN terminals
	300 μ A	300.00 μ A	0.9 to 1.1 × Reference value
	3000 μ A	3000.0 μ A	0.9 to 1.1 × Reference value
AC μ A	300 μ A	030.00 μ A (70 Hz)	0.9 to 1.1 × Reference value
		300.00 μ A (70 Hz)	0.9 to 1.1 × Reference value
	3000 μ A	300.0 μ A (70 Hz)	0.9 to 1.1 × Reference value
		3000.0 μ A (70 Hz)	0.9 to 1.1 × Reference value
DCmA/DCA	OPEN	OPEN	OPEN terminals
	30 mA	30.000 mA	0.9 to 1.1 × Reference value
	300 mA	300.00 mA	0.9 to 1.1 × Reference value
	3 A	3.0000 A	0.9 to 1.1 × Reference value
	10 A	10.000 A	0.9 to 1.1 × Reference value

Table 1-3 Adjustment input values (continued)

Test function	Step	Reference value	Valid reference input	
ACmA/ACA	30 mA	03.000 mA (70 Hz)	0.9 to 1.1 × Reference value	
		30.000 mA (70 Hz)	0.9 to 1.1 × Reference value	
	300 mA	030.00 mA (70 Hz)	0.9 to 1.1 × Reference value	
		300.00 mA (70 Hz)	0.9 to 1.1 × Reference value	
	3 A	0.3000 A (70 Hz)	0.9 to 1.1 × Reference value	
		3.0000 A (70 Hz)	0.9 to 1.1 × Reference value	
	10 A	3.0000 A (70 Hz)	0.9 to 1.1 × Reference value	
		10.000 A (70 Hz)	0.9 to 1.1 × Reference value	
	Capacitance	OPEN	OPEN	With cables connected to CAP/COM terminals
		10 nF	04.000 nF	0.9 to 1.1 × Reference value
10.000 nF			0.9 to 1.1 × Reference value	
100 nF		010.00 nF	0.9 to 1.1 × Reference value	
		100.00 nF	0.9 to 1.1 × Reference value	
1000 nF		0100.0 nF	0.9 to 1.1 × Reference value	
		1000.0 nF	0.9 to 1.1 × Reference value	
10 μF		10.000 μF	0.9 to 1.1 × Reference value	
100 μF		100.00 μF	0.9 to 1.1 × Reference value	
1000 μF		1000.0 μF	0.9 to 1.1 × Reference value	
10 mF		10.000 mF	0.9 to 1.1 × Reference value	
OPEN		OPEN	OPEN terminals (no cables connected to CAP/COM terminals) ^[1]	

1 Calibration Procedures

Using the Front Panel for Adjustments

Table 1-3 Adjustment input values (continued)

Test function	Step	Reference value	Valid reference input
Resistance	SHORT	0 Ω ^[2]	0 Ω from calibrator
	30 M Ω	OPEN	OPEN terminals
		10.000 M Ω	0.9 to 1.1 \times Reference value
	3 M Ω	3.0000 M Ω	0.9 to 1.1 \times Reference value
	300 k Ω	300.00 k Ω	0.9 to 1.1 \times Reference value
	30 k Ω	30.000 k Ω ^[2]	0.9 to 1.1 \times Reference value
	3 k Ω	3.0000 k Ω ^[2]	0.9 to 1.1 \times Reference value
	300 Ω	300.00 Ω ^[2]	0.9 to 1.1 \times Reference value
	30 Ω	30.000 Ω ^[2]	0.9 to 1.1 \times Reference value
	SHORT	SHORT ^[3]	SHORT Ω /COM terminals
Temperature	K type	0000.0 $^{\circ}\text{C}$	0 $^{\circ}\text{C}$ with ambient compensation required
Note: Ensure the multimeter is turned on and stabilized for at least 60 minutes with the K-type thermocouple connected between the multimeter and the calibrator output terminal.			
Diode	SHORT	SHORT	SHORT V/COM terminals
	3 V	2.0000 V	0.9 to 1.1 \times Reference value

[1] After capacitance calibration is completed, calibrate the OPEN item again by removing all cable connections from the Device-Under-Test (DUT).

[2] With a 2-wire connection and compensation enabled at the calibrator.

[3] After resistance calibration is completed, calibrate the SHORT item again by inserting a short bar between the Ω /COM terminals.

Adjustment procedure

NOTE

Review the “Test Considerations” and “Adjustment considerations” before beginning the adjustment procedures.

- 1 Turn the rotary switch to the respective test function position as shown in the adjustment input values table (Table 1-3).
- 2 Unsecure the instrument to enter the adjustment mode. (See “Unsecuring the Instrument for Calibration” on page 38).

NOTE

While in the adjustment mode, press  and  simultaneously to exit the adjustment mode.

- 3 The reference value of the calibration item will be shown on the display.

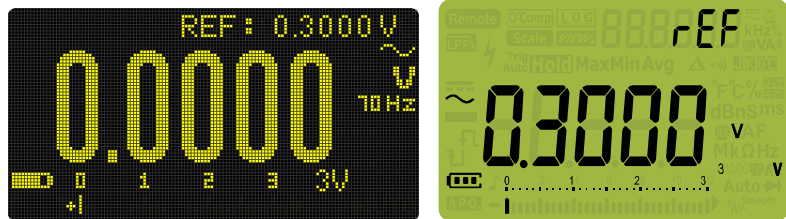

Figure 1-8 Reference value display

- 4 Configure each calibration item.
- 5 Use the arrow keys to select the calibration range.
- 6 Apply the input signal shown in the **Reference value** column of Table 1-3. The analog bar graph displays the input reading. There is no bar graph display for temperature adjustment.

1 Calibration Procedures

Using the Front Panel for Adjustments

NOTE

You are highly recommended to complete the adjustments in the same order as shown in [Table 1-3](#).



- 7 Use the arrow keys to enter the actual applied input values.
- 8 Press  to start the adjustment. **CAL** is shown on the display to indicate that the calibration is in progress.
- 9 Upon completion of each adjustment value, the display will show **PASS**. If the adjustment fails, the instrument will sound a long beep and the calibration error number is shown on the display.

NOTE

If the adjustment fails, check the input value, range, function, and entered adjustment value before repeating the adjustment steps.

- 10 Turn the rotary switch to the next function according to the **Test function** column shown in [Table 1-3](#). Repeat [step 3](#) to [step 8](#) for each adjustment point shown in the adjustment table.
- 11 Verify the adjustments using the “[Performance Verification Tests](#)” on page 27.

Exiting the adjustment mode

- 1 Remove all the shorting plugs and connectors from the instrument.
- 2 Record the new Calibration Count.
- 3 Press  and  simultaneously to exit the Adjustment Mode.
- 4 Cycle the instrument's power. The instrument will then be secured.



Calibration Count

You can query the instrument to determine how many adjustments have been performed.

NOTE

The instrument has been calibrated before it left the factory. You are recommended to record the initial value of the calibration count once you receive the instrument.

The count value increases by one for each calibration point, from 0000 up to the maximum of 19999. After the maximum count, the calibration count will reset to 0. The calibration count can be read from the front panel after the instrument has been unsecured.

- 1 In adjustment mode, press  to view the calibration count.
- 2 Take note of the calibration count to keep track of the number of calibrations that have been performed.
- 3 Press  again to exit the calibration count mode.

Calibration Error Codes

The following errors indicate failures that may occur during a calibration.

Table 1-4 Calibration error codes

Code	Descriptions
Er002	Calibration error: secure code invalid
Er003	Calibration error: serial number code invalid
Er004	Calibration error: calibration aborted
Er005	Calibration error: value out of range
Er006	Calibration error: signal measurement out of range
Er007	Calibration error: frequency out of range
Er008	EEPROM write failure



2 Service and Maintenance

Troubleshooting	52
Checking the Fuse	53
Fuse Replacement	57
Returning the Instrument for Service	61
Replaceable Parts	62
To order replaceable parts	62
Types of Service Available	63
Extended service contracts	63
Obtaining Repair Service (Worldwide)	64

This chapter will help you troubleshoot a failing instrument. It also describes how to obtain repair services and lists the replaceable assemblies.



Troubleshooting

WARNING

To avoid electrical shock, do not perform any servicing unless you are qualified to do so.

CAUTION

Any repair or service which is not covered in this manual should only be performed by qualified personnel.

If the instrument fails to operate, check the batteries and the test leads. Replace them if necessary. If the instrument still does not function, check the operating procedures in this manual. When servicing, use only the specified replacement parts.

The table below will assist you in identifying some basic malfunctions.

Table 2-1 Operating checklist

Malfunction	Identification
No display when powered ON using the rotary switch	<input type="checkbox"/> Verify the batteries health and replace batteries as necessary.
No beeper tone	<input type="checkbox"/> Verify that the beeper is enabled in the multimeter's setup mode.
Failed on current measurement	<input type="checkbox"/> Verify the fuses health and replace the fuses as necessary.
Failed on remote control	<input type="checkbox"/> Verify the optical side of the IR-USB cable connected to the multimeter — the Agilent logo should be facing up. <input type="checkbox"/> Verify the baud rate, data bit, and parity settings in the multimeter's setup mode. (Default values are 9600, 8, and none.) <input type="checkbox"/> Verify that the driver for the IR-USB interface is installed.

Checking the Fuse

It is recommended that you check the fuse(s) of the multimeter before using it. Follow the instructions below to test the fuses inside the multimeter.

NOTE

Refer to [Figure 2-5](#) for the respective positions of Fuse 1 (10 × 35 mm, 440 mA/1000 V fast-acting fuse) and Fuse 2 (10 × 38 mm, 11 A/1000 V fast-acting fuse).

- 1 Turn the rotary switch to the Ω Smart Ω or Ω position and connect the red test lead to the Ω input terminal.
- 2 To test Fuse 1, place the tip of the test probe on the top half of the $\mu\text{A mA}$ input terminal. Ensure that the probe tip touches the metal inside the $\mu\text{A mA}$ input terminal, as shown in [Figure 2-1](#).
- 3 To test Fuse 2, place and touch the tip of the test probe on the left half of the **A** input terminal. Ensure that the probe tip touches the metal inside the **A** input terminal, as shown in [Figure 2-2](#).
- 4 Observe the reading on the instrument's display. Refer to [Table 2-2](#) below for the possible readings that could appear. Replace the fuse when **OL** is displayed.

2 Service and Maintenance

Checking the Fuse

Table 2-2 Fuse displayed readings

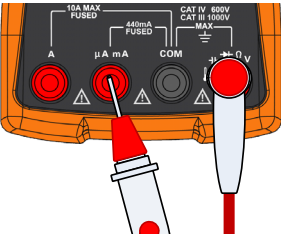
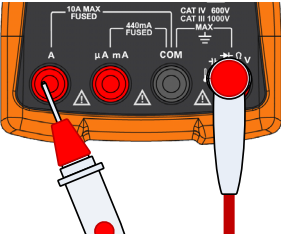
Current input terminal	Fuse	Part number	Fuse rating	Displayed readings	
				Fuse healthy	Replace fuse
	1	2110-1400	440 mA/1000 V	≈102 Ω	OL
	2	2110-1402	11 A/1000 V	≈0.05 Ω	OL

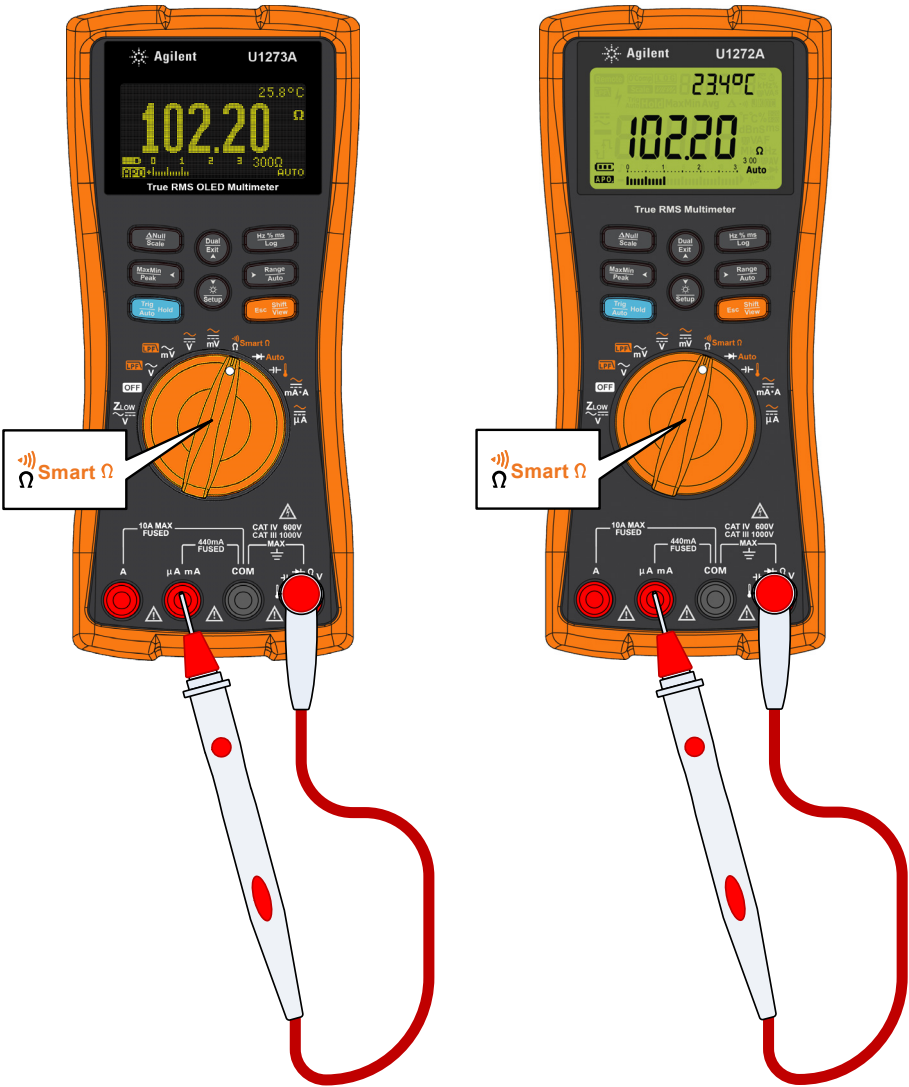

Figure 2-1 Testing Fuse 1

2 Service and Maintenance

Checking the Fuse

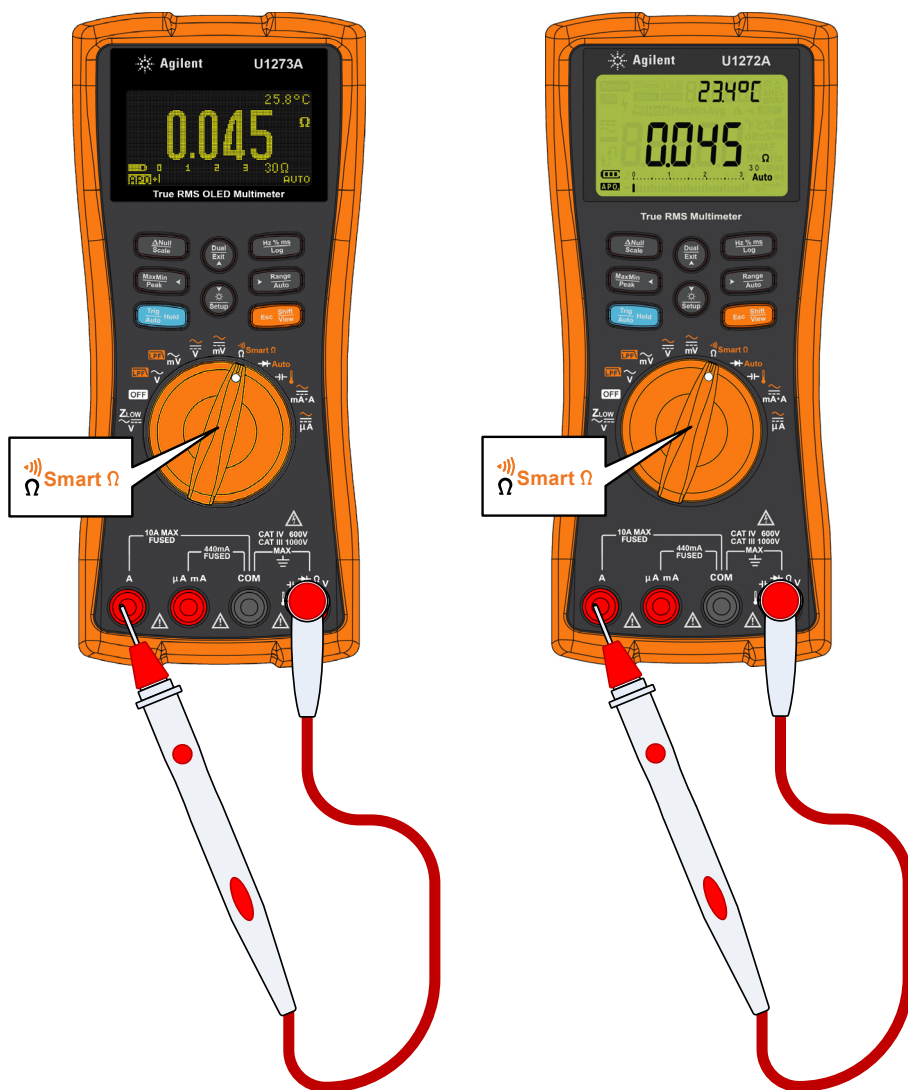

Figure 2-2 Testing Fuse 2

Fuse Replacement

NOTE

No recalibration is required after replacing the fuse.

The current input terminals of your multimeter are fuse protected. The fuses are located next to the battery compartment.

- The **μA mA** terminal is protected by a 10 × 35 mm 440 mA/1000 V 30 kA fast-acting fuse (Fuse 1).
- The **A** terminal is protected by a 10 × 38 mm 11 A/1000 V 30 kA fast-acting fuse (Fuse 2).

If you are certain that the fuse is faulty, replace it with one of the same size and rating.

CAUTION

Before you proceed with the fuse replacement, remove all cable connections to the terminals and ensure that the rotary switch is at the OFF position.

- 1 Open the battery cover.** Lift the tilt stand and loosen screws with a suitable Phillips screwdriver and remove the battery cover.
- 2 Locate the faulty fuse.** Fuse 1 (see [Figure 2-3](#)) is located to the right of batteries, and Fuse 2 (see [Figure 2-4](#)) is located at the bottom of the batteries. See [Figure 2-5](#) for the specific location, size, and ratings of Fuse 1 and 2.

Gently remove the defective fuse by prying one end of the fuse with a flathead screwdriver and removing it out of the fuse bracket. Replace a new fuse of the same size and rating into the center of the fuse holder.

- 3 Close the batter cover.** Place the battery cover back in its original position and tighten the screws.

2 Service and Maintenance

Fuse Replacement

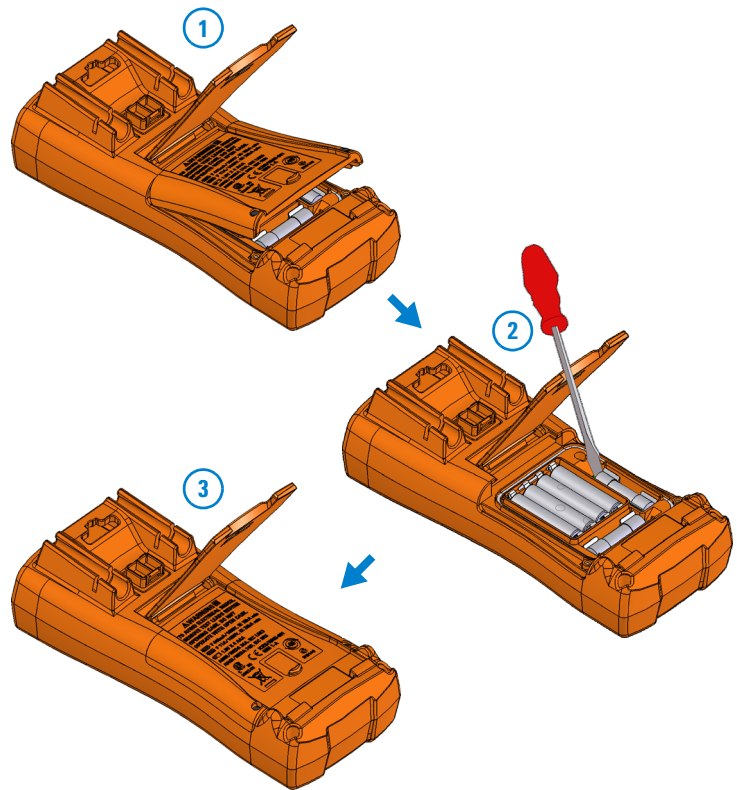

Figure 2-3 Replacing Fuse 1

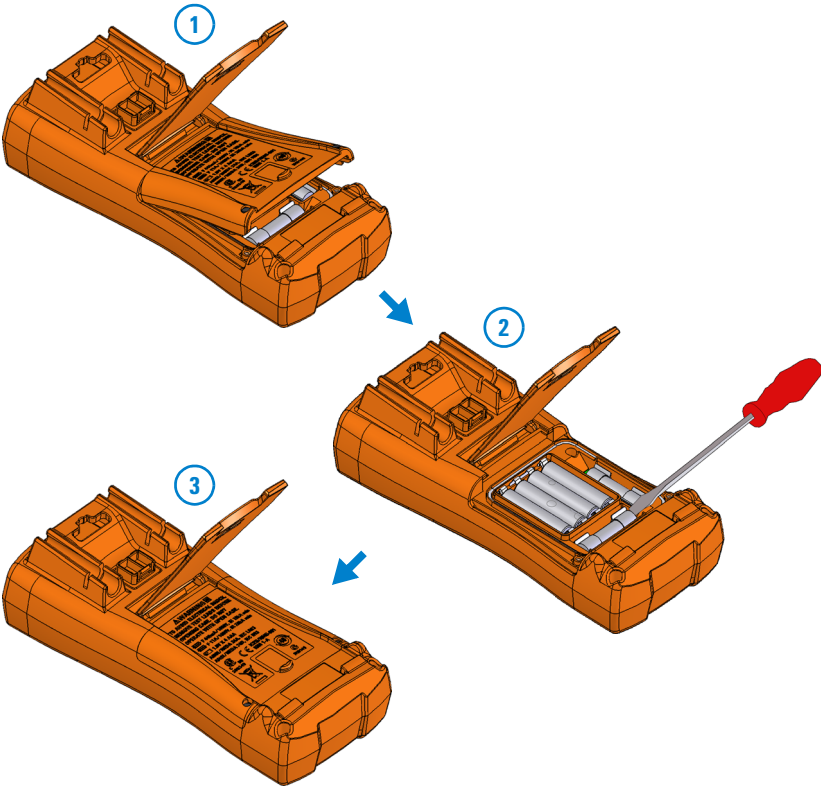

Figure 2-4 Replacing Fuse 2

2 Service and Maintenance

Fuse Replacement

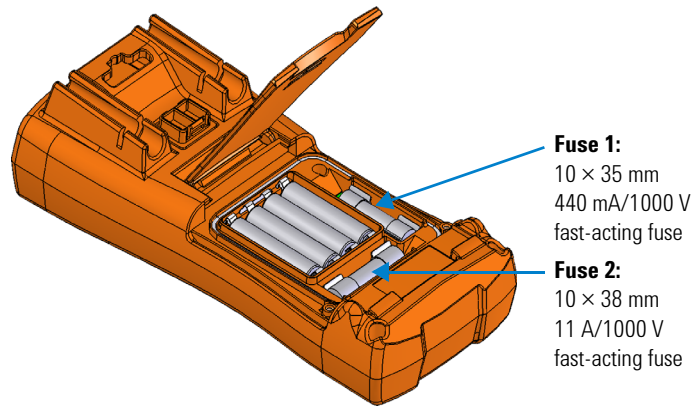

Figure 2-5 Positions of Fuse 1 and Fuse 2

Returning the Instrument for Service

Before shipping your instrument for repair or replacement, Agilent recommends that you acquire the shipping instructions from the Agilent Service Center. A clear understanding of the shipping instructions is necessary to secure your product for shipment.

- 1** Attach a tag to the instrument with the following information:
 - Name and address of owner
 - Instrument model number
 - Instrument serial number
 - Description of the service required or failure indications
- 2** Remove all accessories from the instrument. Do not include accessories unless they are associated with the failure symptoms.
- 3** Place the instrument in its original container with appropriate packaging material for shipping.

If the original shipping container is not available, place your unit in a container which will ensure at least 4 inches of compressible packaging material around all sides for the instrument. Use static-free packaging materials to avoid additional damage to your unit.

NOTE

Agilent suggests that you always insure your shipments.

Replaceable Parts

This section contains information for ordering replacement parts for your instrument. You can find the instrument support parts list at Agilent's Test & Measurement Parts Catalog: <http://www.agilent.com/find/parts>

The parts lists include a brief description of each part with its corresponding Agilent part number.

To order replaceable parts

You can order replaceable parts from Agilent using the Agilent part number. Note that not all parts listed are available as field-replaceable parts.

To order replaceable parts from Agilent, do the following:

- 1** Contact your nearest Agilent Sales Office or Service Center.
- 2** Identify the parts by the Agilent part number shown in the support parts list.
- 3** Provide the instrument model number and serial number.

Types of Service Available

If your instrument fails during the warranty period, Agilent will repair or replace it under the terms of your warranty. After your warranty expires, Agilent offers repair services at competitive prices.

Extended service contracts

Many Agilent products are available with optional service contracts that extend the covered period after the standard warranty expires. If you have such a service contract and your instrument fails during the covered period, Agilent will repair or replace it in accordance with the contract.

Obtaining Repair Service (Worldwide)

To obtain service for your instrument (in-warranty, under service contract, or post-warranty), contact your nearest Agilent Service Center. They will arrange to have your unit repaired or replaced, and can provide warranty or repair-cost information where applicable.

To obtain warranty, service, or technical support information you can contact Agilent at one of the following telephone numbers:

- In the United States: (800) 829-4444
- In Europe: 31 20 547 2111
- In Japan: 0120-421-345

Or use our Web link for information on contacting Agilent worldwide: www.agilent.com/find/assist

Or contact your Agilent representative.

Before shipping your instrument, request the Agilent Service Center to provide shipping instructions, including what components to ship. Agilent recommends that you retain the original shipping carton for use in such shipments.

www.agilent.com

Contact us

To obtain service, warranty, or technical assistance, contact us at the following phone or fax numbers:

United States:

(tel) 800 829 4444 (fax) 800 829 4433

Canada:

(tel) 877 894 4414 (fax) 800 746 4866

China:

(tel) 800 810 0189 (fax) 800 820 2816

Europe:

(tel) 31 20 547 2111

Japan:

(tel) (81) 426 56 7832 (fax) (81) 426 56 7840

Korea:

(tel) (080) 769 0800 (fax) (080) 769 0900

Latin America:

(tel) (305) 269 7500

Taiwan:

(tel) 0800 047 866 (fax) 0800 286 331

Other Asia Pacific Countries:

(tel) (65) 6375 8100 (fax) (65) 6755 0042

Or visit the Agilent World Wide Web at:

www.agilent.com/find/assist

Product specifications and descriptions in this document are subject to change without notice. Always refer to the Agilent Web site for the latest revision.

© Agilent Technologies, Inc., 2010–2014

Eleventh Edition, April 18, 2014
U1271-90020



Agilent Technologies