

USBSQ USB 2.0 Signal Quality Analysis Application

Electrical
Testing Notes

Notices

© Keysight Technologies, Inc. 2003-2014

No part of this manual may be reproduced in any form or by any means (including electronic storage and retrieval or translation into a foreign language) without prior agreement and written consent from Keysight Technologies, Inc. as governed by United States and international copyright laws.

Manual Part Number

Version 04.00.0000

Edition

November 15, 2014

Available in electronic format only

Published by:
Keysight Technologies, Inc.
1900 Garden of the Gods Road
Colorado Springs, CO 80907 USA

Trademarks

Microsoft®, MS-DOS®, Windows®, Windows 2000®, and Windows XP® are U.S. registered trademarks of Microsoft Corporation.

Adobe®, Acrobat®, and the Acrobat Logo® are trademarks of Adobe Systems Incorporated.

Warranty

The material contained in this document is provided “as is,” and is subject to being changed, without notice, in future editions. Further, to the maximum extent permitted by applicable law, Keysight disclaims all warranties, either express or implied, with regard to this manual and any information contained herein, including but not limited to the implied warranties of merchantability and fitness for a particular purpose. Keysight shall not be liable for errors or for incidental or consequential damages in connection with the furnishing, use, or performance of this document or of any information contained herein. Should Keysight and the user have a separate written agreement with warranty terms covering the material in this document that conflict with these terms, the warranty terms in the separate agreement shall control.

Technology Licenses

The hardware and/or software described in this document are furnished under a license and may be used or copied only in accordance with the terms of such license.

Restricted Rights Legend

If software is for use in the performance of a U.S. Government prime contract or subcontract, Software is delivered and licensed as “Commercial computer software” as defined in DFAR 252.227-7014 (June 1995), or as a “commercial item” as defined in FAR 2.101(a) or as “Restricted computer software” as defined in FAR 52.227-19 (June 1987) or any equivalent agency regulation or contract clause. Use, duplication or disclosure of Software is subject to Keysight Technologies’ standard commercial license terms, and non-DOD Departments and Agencies of the U.S. Government will receive no greater than Restricted Rights as defined in FAR 52.227-19(c)(1-2) (June 1987). U.S. Govern-

ment users will receive no greater than Limited Rights as defined in FAR 52.227-14 (June 1987) or DFAR 252.227-7015 (b)(2) (November 1995), as applicable in any technical data.

Safety Notices

CAUTION

A **CAUTION** notice denotes a hazard. It calls attention to an operating procedure, practice, or the like that, if not correctly performed or adhered to, could result in damage to the product or loss of important data. Do not proceed beyond a **CAUTION** notice until the indicated conditions are fully understood and met.

WARNING

A **WARNING** notice denotes a hazard. It calls attention to an operating procedure, practice, or the like that, if not correctly performed or adhered to, could result in personal injury or death. Do not proceed beyond a **WARNING** notice until the indicated conditions are fully understood and met.

USB 2.0 Signal Analysis—At a Glance

The DSOX4USBSQ/DSOX6USBSQ USB 2.0 Signal Quality Analysis application for the InfiniiVision 4000/6000 X-Series oscilloscopes supports two use models:

- You can quickly test USB signal quality in-circuit with real-world packets. In this case:
 - You can use test fixtures as an easy way to probe signals.
 - The USBSQ analysis application's Auto Setups may need to be adjusted before analyzing real-world packets.
- You can verify signal quality to USB 2.0 compliance specifications. In this case:
 - You must use the test fixtures, equipment, and test setups required by the USB Implementers Forum (USB-IF).
 - The USBSQ analysis application's Auto Setups should work as is for the required test packets.

The signal quality analysis application:

- Lets you select Hi-Speed, Full Speed, or Low Speed tests for Devices and Hosts. Hubs can be tested by running both device and hosts tests against the hub.
- Runs all the signal quality tests for the selected speed and device type combination.
- Automatically sets up the oscilloscope for the selected tests.
- Provides detailed results information for each test that has been run.
- Lets you save the detailed results information to an HTML report.

In This Book

This manual contains notes on the electrical tests that are performed by the DSOX4USBSQ/DSOX6USBSQ USB 2.0 Signal Quality Analysis application; it describes the equipment used and how the tests are performed. It has these chapters:

- **Chapter 1**, “Preparing for Signal Quality Analysis,” starting on page 9
- **Chapter 2**, “Device Signal Quality Testing,” starting on page 19
- **Chapter 3**, “Host Signal Quality Testing,” starting on page 39
- **Chapter 4**, “Hub Upstream Signal Quality Testing,” starting on page 55
- **Chapter 5**, “Hub Downstream Signal Quality Testing,” starting on page 69
- **Chapter 6**, “Saving Test Results to an HTML File,” starting on page 85

- **Appendix A**, “Probing Hi-Speed Signals with InfiniiMode Using SQiDD as a Feedthrough,” starting on page 87

See Also

- The USB 2.0 developers documents are available at the USB Implementers Forum web site, "<http://www.usb.org/developers/docs>".

Contents

USB 2.0 Signal Analysis—At a Glance / 3

1 Preparing for Signal Quality Analysis

Oscilloscope Requirements / 9

Fixtures for Signal Quality Tests / 10

Fixtures for Hi-Speed Signal Quality Tests / 10

Fixture for Full/Low Speed Signal Quality Tests / 13

Probe Requirements / 13

Differential Probe Connection for Hi-Speed Signal Quality Tests / 14

Single-Ended SMA Cable Connection for Hi-Speed Signal Quality Tests / 15

Single-Ended Probe Connection for Full/Low Speed Signal Quality Tests / 15

Miscellaneous Cables and Devices / 16

Additional Equipment and Set Up for Signal Quality Compliance Testing / 16

High-Speed Electrical Test Bed Computer / 17

Additional Set Up for Signal Quality Compliance Testing / 18

2 Device Signal Quality Testing

Device Hi-Speed Signal Quality Test / 19

Device Hi-Speed Connection - Differential Probe / 24

Device Hi-Speed Connection - SMA Cables / 25

Device Hi-Speed Compliance Test Packets / 26

Device Full Speed Signal Quality Test / 27

Device Full Speed Connection / 30

- Device Full Speed Compliance Test Packets / 32
- Device Low Speed Signal Quality Test / 33
 - Device Low Speed Connection / 36
 - Device Low Speed Compliance Test Packets / 37

3 Host Signal Quality Testing

- Host Hi-Speed Signal Quality Test / 39
 - Host Hi-Speed Connection - Differential Probe / 42
 - Host Hi-Speed Connection - SMA Cables / 43
 - Host Hi-Speed Compliance Test Packets / 44
- Host Full Speed Signal Quality Test / 45
 - Host Full Speed Connection / 48
- Host Low Speed Signal Quality Test / 50
 - Host Low Speed Connection / 52

4 Hub Upstream Signal Quality Testing

- Hub Upstream Hi-Speed Signal Quality Test / 55
 - Hub Upstream Hi-Speed Connection - Differential Probe / 58
 - Hub Upstream Hi-Speed Connection - SMA Cables / 59
 - Hub Upstream Hi-Speed Compliance Test Packets / 60
- Hub Upstream Full Speed Signal Quality Test / 61
 - Hub Upstream Full Speed Connection / 64
 - Hub Upstream Full Speed Compliance Test Packets / 66

5 Hub Downstream Signal Quality Testing

- Hub Downstream Hi-Speed Signal Quality Test / 69
 - Hub Downstream Hi-Speed Connection - Differential Probe / 72
 - Hub Downstream Hi-Speed Connection - SMA Cables / 73
 - Hub Downstream Hi-Speed Compliance Test Packets / 74
- Hub Downstream Full Speed Signal Quality Test / 76

Hub Downstream Full Speed Connection / 79

Hub Downstream Low Speed Signal Quality Test / 81

Hub Downstream Low Speed Connection / 83

6 Saving Test Results to an HTML File

A Probing Hi-Speed Signals with InfiniiMode Using SQiDD as a Feedthrough

Index

1 Preparing for Signal Quality Analysis

Oscilloscope Requirements / 9
Fixtures for Signal Quality Tests / 10
Probe Requirements / 13
Miscellaneous Cables and Devices / 16

This chapter describes the equipment and software required for performing signal quality analysis with the 4000/6000 X-Series oscilloscope and the DSOX4USBSQ/DSOX6USBSQ USB 2.0 Signal Quality Analysis application.

Oscilloscope Requirements

The DSOX4USBSQ/DSOX6USBSQ USB 2.0 Signal Quality Analysis application requires a Keysight InfiniiVision 4000/6000 X-Series oscilloscope, firmware version 3.10 or later.

For Hi-Speed Tests Hi-Speed tests require a 1.5 GHz bandwidth model oscilloscope.

Hi-Speed tests on a 2-channel oscilloscope with single-ended SMA cable connections is not supported because the sample rate will not meet the 5 GSa/s rate that is required. Using a differential probe on a 2-channel oscilloscope works fine.

For Full and Low Speed Tests Full and Low Speed tests can be performed with 200 MHz, 350 MHz, 500 MHz, 1 GHz, or 1.5 GHz bandwidth model oscilloscopes.

Full Speed testing is best on a 4-channel oscilloscope because when using a 2-channel oscilloscope, channels 1 and 2 are non-interleaved and the sample rate will be below the 4 GSa/s that the USB-IF testing procedures require. If Full Speed tests are run on a 2-channel oscilloscope, interpolation is used on the data.

For Optional USB 2.0 Triggering and Decode in the Oscilloscope

The optional DSOX4USBH/DSOX6USBH and DSOX4USBFL/DSOX6USBFL products (for USB 2.0 Hi-Speed and Full/Low-Speed triggering and decode, respectively) can be very useful tools for identifying and triggering on packets that you might want to run the USB signal quality tests on.

Fixtures for Signal Quality Tests

Two different fixtures are used for Hi-Speed tests; one is for devices and other is for hosts. See **“Fixtures for Hi-Speed Signal Quality Tests”** on page 10.

One fixture is used for Full and Low Speed tests. See **“Fixture for Full/Low Speed Signal Quality Tests”** on page 13.

Fixtures for Hi-Speed Signal Quality Tests

Hi-Speed testing requires one of these test fixtures:

- Device Hi-Speed Signal Quality Test Fixture, part number E2649-66401.



This fixture can be ordered using model number E2666B, which includes two RF SMA (m) vertical 50-ohm termination connectors, two 4 inch USB A-to-B cables (E2646-61601), a USB 2.0 Plug to USB 2.0 Micro Plug, and a cable for powering the fixture from a standard USB host port.

This fixture can be ordered using the Keysight part number E2649-60001, which includes two RF SMA (m) vertical 50-ohm termination connectors and two 4 inch USB A-to-B cables (E2646-61601).

- Host Hi-Speed Signal Quality Test Fixture, part number E2649-66402.

1 Preparing for Signal Quality Analysis



This fixture can be ordered using model number E2667B, which includes two RF SMA (m) vertical 50-ohm termination connectors, two 4 inch USB A-to-B cables (E2646-61601), a USB 2.0 Plug to USB 2.0 Micro Plug, and a cable for powering the fixture from a standard USB host port.

This fixture can be ordered using the Keysight part number E2649-60002, which includes two RF SMA (m) vertical 50-ohm termination connectors and two 4 inch USB A-to-B cables (E2646-61601).

These Hi-Speed Signal Quality test fixtures are powered by a 5 V power supply, which can be ordered using Keysight part number 0950-2546. Equivalent power supplies can also be used.

NOTE

The Hi-Speed fixture part numbers E2649-66401 and E2649-66402 are provided for identification purposes only and cannot be used for ordering.

Older Versions of the Hi-Speed Signal Quality Test Fixtures

Older versions of the Hi-Speed signal quality test fixtures exist and may be used:

- Device Hi-Speed Signal Quality Test Fixture, part number E2645-66507.
- Host Hi-Speed Signal Quality Test Fixture, part number E2645-66508.

When using these older fixtures with the 1131A, 1133A, or 1134A InfiniiMax differential probes, you also need the Keysight header adapter, part number 01131-68703. This header adapter is included with E2669A and E2678A (purchased after October 2003).

Fixture for Full/Low Speed Signal Quality Tests

Full and Low Speed testing require this test fixture:

- E2646A/B SQiDD board test fixture.

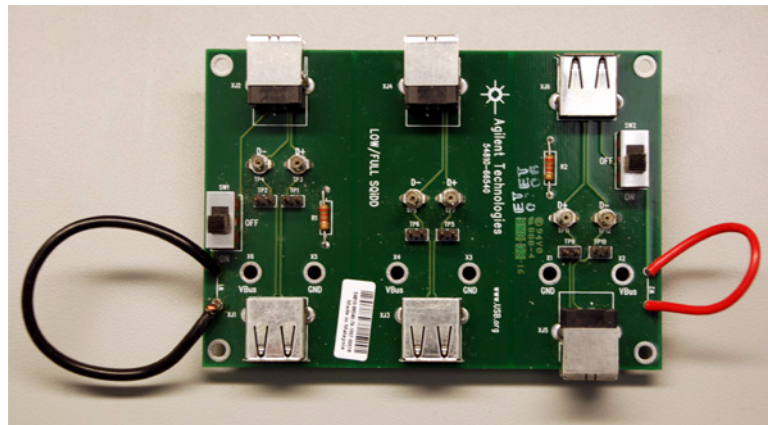

This fixture can be ordered using the model number E2646A/B.

Probe Requirements

Hi-Speed tests require a differential probe (see [“Differential Probe Connection for Hi-Speed Signal Quality Tests”](#) on page 14) or two single-ended SMA cable connections (see [“Single-Ended SMA Cable Connection for Hi-Speed Signal Quality Tests”](#) on page 15).

Low and Full Speed host tests require single-ended probes (see [“Single-Ended Probe Connection for Full/Low Speed Signal Quality Tests”](#) on page 15).

Differential Probe Connection for Hi-Speed Signal Quality Tests

NOTE

The N2750A Series InfiniiMode probes cannot be used with the Hi-Speed Signal Quality test fixtures because they have damping resistors and the USB test fixture also has damping resistors specifically designed for the E2678A socketed probe heads.

However, if you are not verifying signal quality to USB 2.0 specifications (in other words, you are testing USB signal quality in-circuit with real-world packets), and you just need a feed-through that will let you probe Hi-Speed signals, you can use the E2646A/B SQiDD test fixture (normally used for Full and Low Speed testing) and InfiniiMode probes. See [Appendix A](#), “Probing Hi-Speed Signals with InfiniiMode Using SQiDD as a Feedthrough,” starting on page 87.

When using a differential probe connection for Hi-Speed signal quality tests, Keysight recommends the 1131A, 1133A, or 1134A InfiniiMax differential probes and the E2678A socketed probe head or the E2669A differential connectivity kit.

When setting up the Keysight 113xA differential probe for connection to the Hi-Speed signal quality test fixture:

- Attach the socketed probe head to the differential probe amplifier.
- Handle the socketed probe head and header adapter carefully.
- For durability, epoxy can be used to strengthen the assembly. Only apply epoxy to back (noncomponent) side of probe head.



Figure 1 Differential Probe Setup

NOTE

In certain test situations, there may not be a ground connection between the oscilloscope and the device under test (DUT). This may lead to the signal seen by the differential probe to be modulated up and down due to the mid-frequency switching power supply. Connecting the oscilloscope ground to the DUT ground will be required to establish a common ground reference.

Single-Ended SMA Cable Connection for Hi-Speed Signal Quality Tests

The Hi-Speed signal quality test fixtures have SMA connectors for probing with SMA cables.

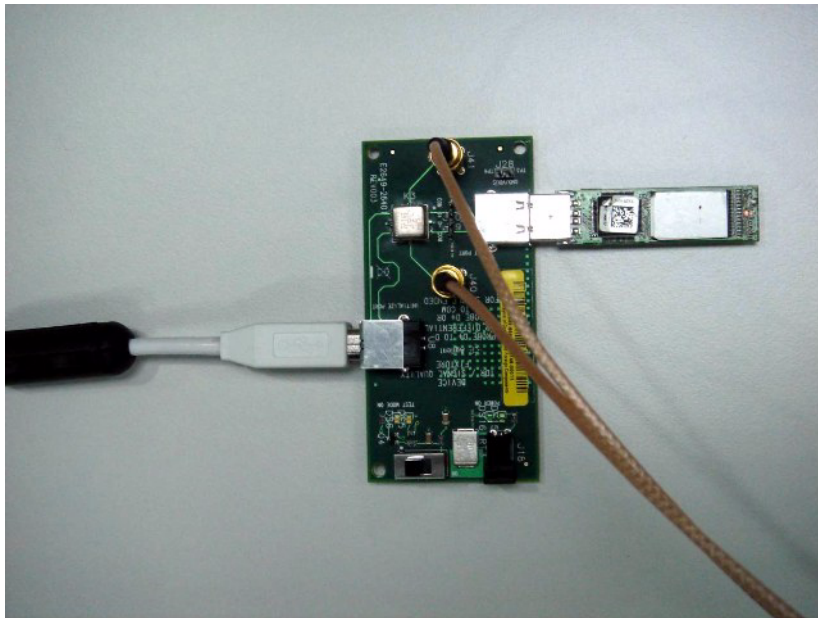

Single-Ended Probe Connection for Full/Low Speed Signal Quality Tests

Low and Full Speed host tests require two single-ended probes.

Low and Full Speed device tests require three single-ended probes – the third probe is for the adjacent D-/D+ signal.

The passive probes that are included with the oscilloscope are sufficient.

Miscellaneous Cables and Devices

The following table lists miscellaneous cables and devices required for certain tests.

Table 1 Miscellaneous Cables and Devices

| Equipment Required | Tests and Quantities | | | |
|--|----------------------|--------------|-----------------|----------------|
| | Host Hi-Speed | Hub Hi-Speed | Device Hi-Speed | Low/Full Speed |
| 5 m USB cable (any listed on USB-IF web site). | 1 | 1 | 1 | as needed |
| 1.5 m USB cable (any listed on USB-IF web site). | 1 | 1 | n/a | n/a |
| 1 m USB cable (any listed on USB-IF web site). | n/a | n/a | n/a | as needed |
| Modular AC power cord. | 2 | 2 | 2 | n/a |
| Hi-Speed USB Hub (any listed on USB-IF web site). | 1 | n/a | n/a | n/a |
| Hi-Speed USB Device (any listed on USB-IF web site). | 1 | n/a | n/a | n/a |
| USB self-powered hub (and power supply). These are the hubs used for compliance testing and are available from the USB-IF. For development testing, in most cases, a hub that has passed USB compliance testing can be used. | n/a | n/a | n/a | 5 |

Additional Equipment and Set Up for Signal Quality Compliance Testing

When performing USB 2.0 signal quality compliance testing (instead of testing the signal quality of real-world packets):

- You need a high-speed electrical test bed computer and the High-Speed Electrical Test Tool Kit software (USBHSET) in order to generate compliance test packets. See **“High-Speed Electrical Test Bed Computer”** on page 17.
- See also: **“Additional Set Up for Signal Quality Compliance Testing”** on page 18.

High-Speed Electrical Test Bed Computer

The high-speed electrical test bed computer hosts a USB 2.0 compliance host controller for hi-speed hub or device electrical test, or serves as a test bed host for a USB 2.0 host controller under test. For instructions on configuring this computer, refer to the High-Speed Electrical Test Toolkit Setup Instruction document which comes with the **“High-Speed Electrical Test Tool Kit Software”** on page 17.

Table 2 High-Speed Electrical Test Bed Computer

| Equipment Required | Tests and Quantities | | | |
|--|----------------------|--------------|-----------------|----------------|
| | Host Hi-Speed | Hub Hi-Speed | Device Hi-Speed | Low/Full Speed |
| High-Speed Electrical Test Bed Computer | 1 | 1 | 1 | 1 |
| High-Speed Electrical Test Tool Kit software (USBHSET) | 1 | 1 | 1 | 1 |

High-Speed Electrical Test Tool Kit Software

You can download the High-Speed Electrical Test Tool Kit software (USBHSET) from the developers tools page at the USB Implementers Forum web site, **["http://www.usb.org/developers/tools"](http://www.usb.org/developers/tools)**.

The High-Speed Electrical Test Tool Kit software contains and uses a proprietary EHCI driver stack. The use of this proprietary EHCI driver stack facilitates the electrical testing that requires direct control of the command registers of the USB EHCI host controllers. The end result is a much more robust test bed environment.

Because the proprietary EHCI driver stack is designed for debug and test validation purposes, this driver stack does not support the normal functionality as found in the EHCI drivers from Microsoft (or the device vendor). Therefore, an automatic driver stack switching function has been implemented into the Hi-speed Electrical Test Tool for easy switching between the proprietary EHCI driver stack and that from Microsoft.

Upon invocation of the HS Electrical Test Tool software, the driver stack will automatically switch to the Intel proprietary EHCI driver stack.

Upon exit of the HS Electrical Test Tool software, the driver stack will automatically switch to the Microsoft EHCI driver stack.

Additional Set Up for Signal Quality Compliance Testing

When performing USB 2.0 signal quality compliance testing (instead of testing the signal quality of real-world packets), be sure to take these additional set up steps:

- 1** Turn on the oscilloscope to allow 30 minutes of warm up time prior to use.
- 2** When performing signal quality compliance testing, if the ambient temperature has changed more than 5 degrees from the previous calibration, perform the user calibration procedure built into the oscilloscope.
- 3** Compensate the passive probes (see the oscilloscope *user's guide*).
- 4** Calibrate all the probes.

2 Device Signal Quality Testing

Device Hi-Speed Signal Quality Test / 19
Device Full Speed Signal Quality Test / 27
Device Low Speed Signal Quality Test / 33

Device Hi-Speed Signal Quality Test

Table 3 Equipment Used in Device Hi-Speed Signal Quality Tests

| Quantity | Item | Description/Model |
|----------|--|--|
| 1 | Oscilloscope | Keysight 4000/6000 X-Series >1.5 GHz bandwidth model |
| 1 | Oscilloscope probing solution: | |
| | ▪ Differential probe | Keysight 113xA with E2678A or E2669A |
| | ▪ SMA cables | Keysight 15443A matched cable pair or equivalent |
| 1 | Host test bed computer | Any computer with the Windows XP, Windows 7, or Windows 8 operating system and hi-speed USB ports. |
| 1 | Device Hi-Speed Signal Quality test fixture and 4" USB cable | Keysight E2649-66401 |
| 1 | 5V power supply | Keysight 0950-2546 or equivalent |

To set up and run the Device Hi-Speed signal quality tests:

- 1 Connect the USB Device, test fixtures, and equipment:

- If you are probing the test fixture using a differential probe, see “**Device Hi-Speed Connection - Differential Probe**” on page 24.
- If you are probing the test fixture using SMA cables, see “**Device Hi-Speed Connection - SMA Cables**” on page 25.

2 Set up the test signal/packet that will be analyzed.

To set up the test packets used for compliance testing, see “**Device Hi-Speed Compliance Test Packets**” on page 26.

3 On the Device Hi-Speed Signal Quality test fixture, place the TEST switch (S1) in the ON position.

Verify the yellow TEST LED is lit.

4 On the oscilloscope's front panel, press the **[Analyze]** key.

5 In the Analyze Menu, press the **Features** softkey; then, select **USB Signal Quality**.

6 Press the **Test** softkey and select the **Device Hi-Speed Signal Quality** test.

7 Press the **Settings** softkey. In the USB Signal Quality Settings Menu:

- a** Press the **Test Connection** softkey and select whether you are using a **Single-ended** (with SMA cables) or **Differential** probe connection.
- b** If you are using a differential connection, press the **Source** softkey and select the analog input source channel connected to the differential probe.

If you are using a single-ended (SMA cables) connection, press the **DP SMA** softkey and select the analog input source channel connected to the D+ signal. Then, press the **DN SMA** softkey and select the analog input source channel connected to the D- signal.

On 4-channel oscilloscopes, you are forced to use different channel pairs for the D+ and D- signals. This provides the maximum sample rate. (Channels 1 and 2 are one pair and channels 3 and 4 are the other pair.)

Hi-Speed tests using single-ended SMA cable connections are not supported on 2-channel oscilloscopes because the sample rate does not meet the required 5 GSa/s.

- c** Press the **Test Type** softkey and select **Near-end** or **Far-end**.

The terms "near-end" and "far-end" are based on which end of the cable the test fixture is attached in relation to the device being tested. The point where measurements are made dictates what eye template is used.

8 Press the **Auto Setup** softkey to automatically set up the oscilloscope for the selected test.

For optimal test results, you can make adjustments to the auto setup. Generally, you want one packet of data, plus the time of one bit on each end, across the oscilloscope's display. Also, vertical scale and offset should be adjusted so that the signals take six vertical divisions without being clipped.

You should see the transmitted test packet on the oscilloscope as below.

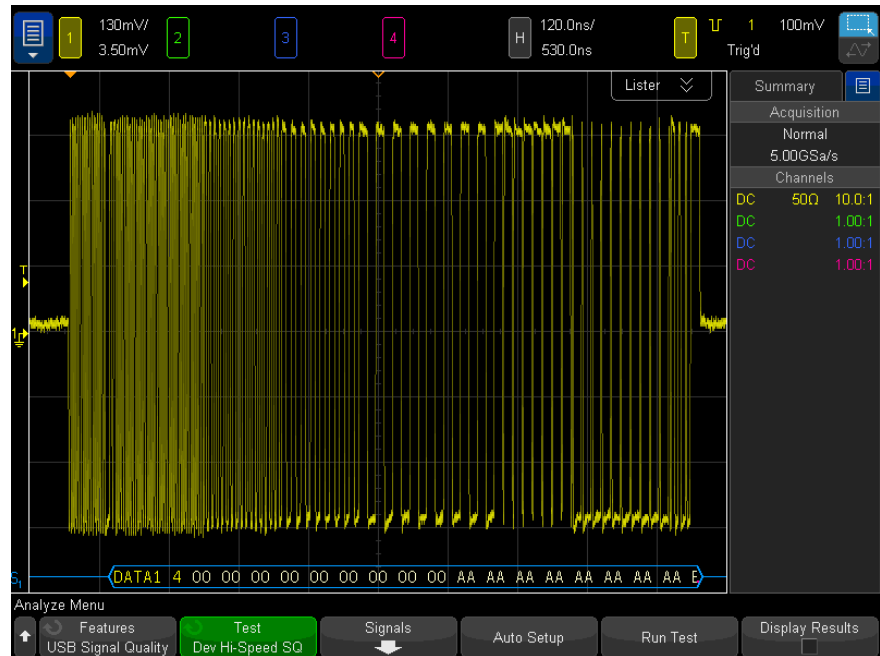

- 9 Press the **Run Test** softkey to run the selected signal quality test.

When tests are run, the oscilloscope stops acquisitions if they are running, analyzes the data on screen, and then displays the results.

NOTE

Tests can take several minutes to run and cannot be cancelled once started.

When the test completes, the results are automatically displayed. You can press the **Display Results** softkey to disable or reenble the test results display.

2 Device Signal Quality Testing

The screenshot displays the 'Near End High Speed Signal Quality Test Results' window. The interface includes a top toolbar with various icons and a bottom 'Analyze Menu' with buttons for 'Features', 'Test', 'Signals', 'Auto Setup', 'Run Test', and 'Display Results'. The 'Test' button is highlighted in green.

Near End High Speed Signal Quality Test Results

Required Tests

- Overall result: **pass!**
- Sync result: **sync passes**
- Signal eye: **eye passes**
- EOP width: 7.97 bits
- EOP width: **passes**
- Measured signaling rate: 480.0444 MHz
- signal rate: **passes**
- Edge Monotonicity: 0 mV
- Monotonic Edge: **passes**
- Rising Edge Rate: 1240.42 V/us (615.95 ps equivalent risetime)
- **passes**
- Falling Edge Rate: 1140.23 V/us (561.29 ps equivalent falltime)
- **passes**

Additional Information

- Consecutive jitter range: -104.117 ps to 97.587 ps, RMS jitter 44.914 ps
- Paired JK jitter range: -39.902 ps to 59.448 ps, RMS jitter 18.246 ps
- Paired KJ jitter range: -52.657 ps to 65.521 ps, RMS jitter 17.802 ps

Tracking Information

- Analysis Performed: 2013/2/8 14:21

Summary

Acquisition
Normal
5.00GSa/s

Channels

| | | |
|----|-----|--------|
| DC | 50Ω | 10.0:1 |
| DC | | 1.00:1 |
| DC | | 1.00:1 |
| DC | | 1.00:1 |

Signal Data and File

Analyze Menu

- Features
- Test**
- Signals
- Auto Setup
- Run Test
- Display Results

USB Signal Quality Dev Hi-Speed SQ



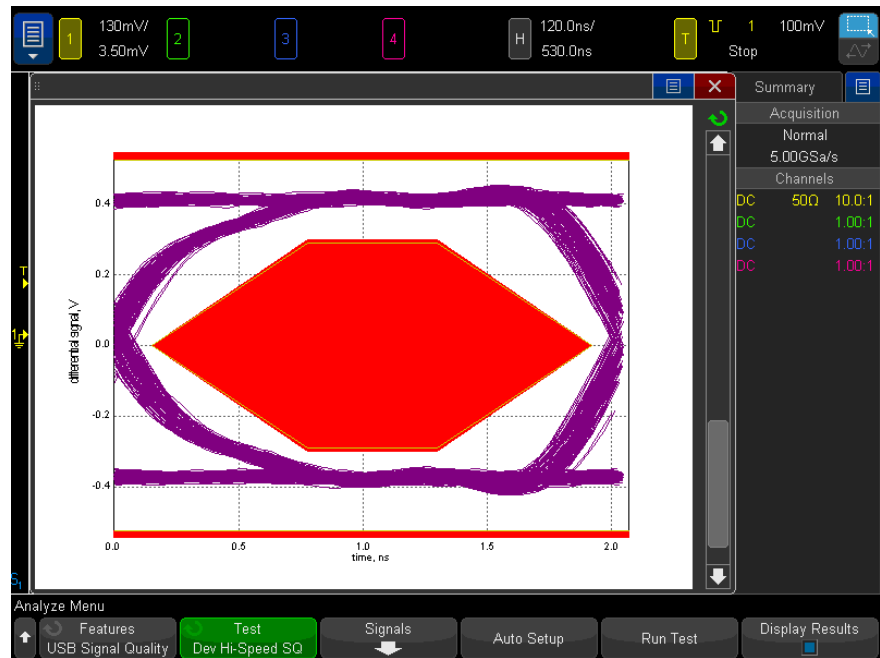

The analyzed acquisition remains on screen and can be viewed by moving or dismissing the results dialog box.

You can run tests when the oscilloscope is already stopped. This is useful in the case of embedded hosts (and other cases) where the device under test (DUT) may not easily be placed in a test mode, and you want to analyze already acquired data.

See Also · [Chapter 6](#), “Saving Test Results to an HTML File,” starting on page 85

Device Hi-Speed Connection - Differential Probe

Perform these connection steps:

- 1 Attach the 5V power supply to J5 of the E2649-66401 Device Hi-Speed signal quality test fixture.

Leave the TEST switch at the OFF position.

Verify the green POWER LED is lit and the yellow TEST LED is not lit.

- 2 Connect the [TEST PORT] of the Device Hi-speed Signal Quality test fixture into the upstream facing port of the device under test, using the 4" USB cable.
- 3 Connect the [INIT PORT] of the test fixture to a Hi-speed capable port of the Test Bed Computer, using a USB cable.
- 4 Apply power to the device.
- 5 Attach the differential probe to D+/D- of TP2 on the test fixture. Ensure the + polarity on the probe lines up with D+.
- 6 Please terminate the fixture's SMA connectors with 50 Ohm terminators.

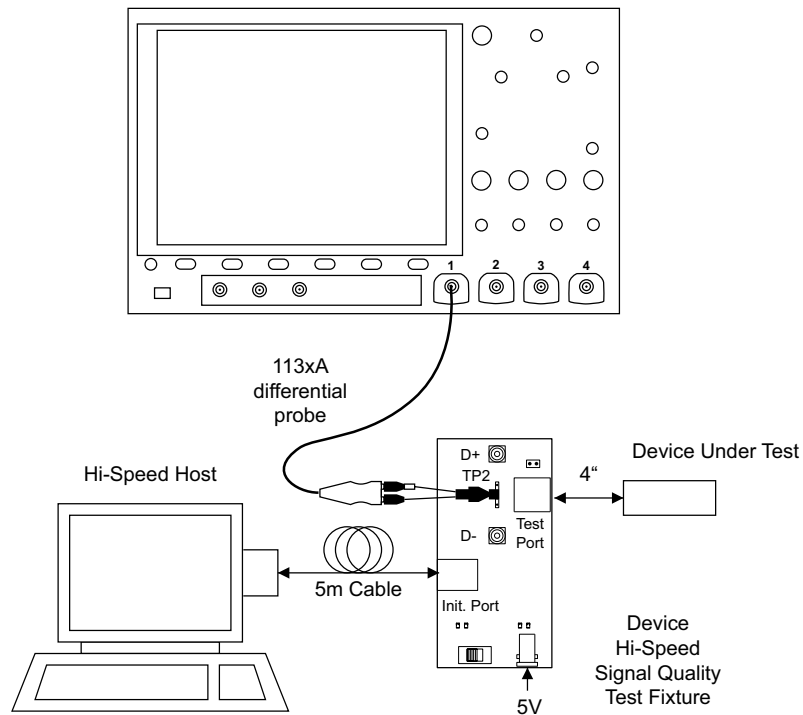

Device Hi-Speed Connection - SMA Cables

- 1 Attach the 5V power supply to J5 of the E2649-66401 Device Hi-Speed signal quality test fixture.

Leave the TEST switch at the OFF position.

Verify the green POWER LED is lit and the yellow TEST LED is not lit.

- 2 Connect the [TEST PORT] of the Device Hi-speed Signal Quality test fixture into the upstream facing port of the device under test, using the 4" USB cable.
- 3 Connect the [INIT PORT] of the test fixture to a Hi-speed capable port of the Test Bed Computer, using the 5 meter USB cable.
- 4 Apply power to the device.
- 5 Attach the SMA cables to the SMA connectors D+ and D- on the test fixture.

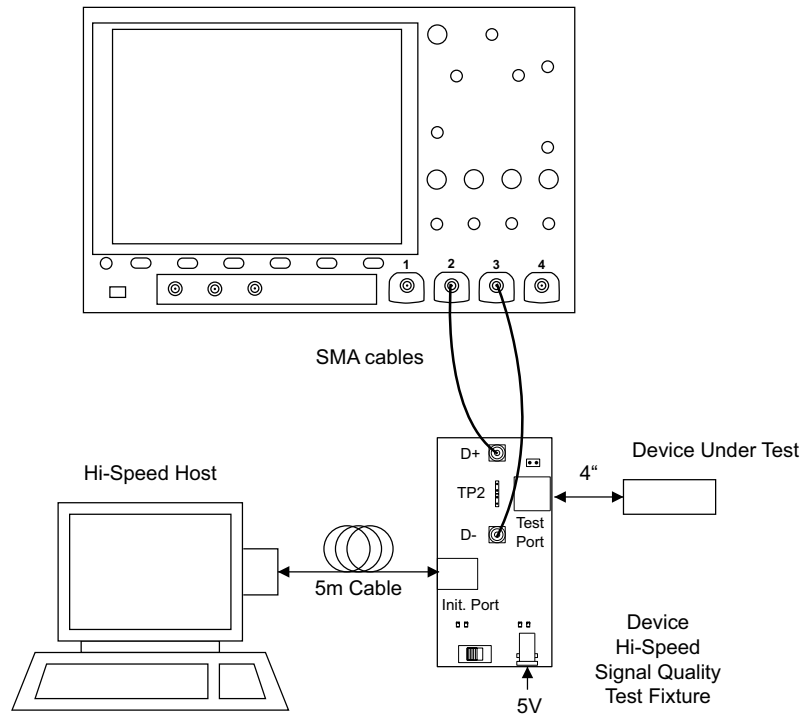

Device Hi-Speed Compliance Test Packets

To set up the Host computer to transmit compliance test packets, perform these steps:

- 1 Invoke the HS Electrical Test Tool software on the Hi-Speed Electrical Test Bed computer.

- 2 Select **Device** and click the **TEST** button to open the Device Test dialog box.

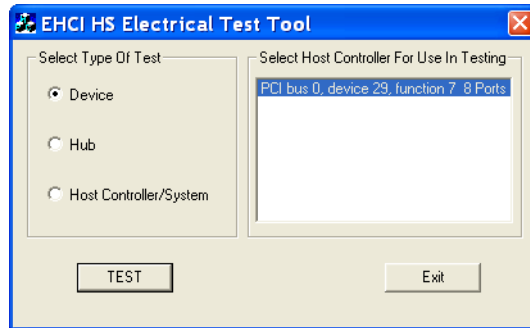

- 3 In the Device Test dialog box, the device under test should be enumerated with the device's VID shown together with the root port in which it is connected.
- 4 Select **TEST_PACKET** from the **Device Command** drop down menu, and click **EXECUTE**. This forces the device under test to continuously transmit test packets.

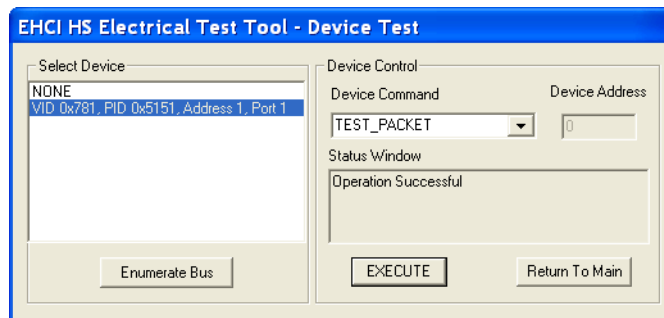

Device Full Speed Signal Quality Test

Table 4 Equipment Used in Upstream Full Speed Signal Quality Test

| Quantity | Item | Description/Model |
|----------|--------------|-----------------------------|
| 1 | Oscilloscope | Keysight 4000/6000 X-Series |

Table 4 Equipment Used in Upstream Full Speed Signal Quality Test (continued)

| Quantity | Item | Description/Model |
|----------|------------------------|--|
| 3 | Passive probes | Probes included with the oscilloscope are sufficient. |
| 1 | Host test bed computer | Any computer with the Windows XP, Windows 7, or Windows 8 operating system and hi-speed USB ports. |
| 1 | SQiDD board | Keysight E2646A/B |
| 1 | full speed USB device | Intel Create and Share USB camera, P/N 735147-001, Model #: CS330 |
| 5 | USB self-powered hubs | Any listed on USB-IF web site |
| 6 | 5 meter USB cables | Any listed on USB-IF web site |

To set up and run the Device Full Speed signal quality tests:

- 1 Connect the USB Device, test fixtures, and equipment. See “**Device Full Speed Connection**” on page 30.
- 2 Set up the test signal/packet that will be analyzed.

To set up the test packets used for compliance testing, see “**Device Full Speed Compliance Test Packets**” on page 32.

- 3 On the oscilloscope's front panel, press the **[Analyze]** key.
- 4 In the Analyze Menu, press the **Features** softkey; then, select **USB Signal Quality**.
- 5 Press the **Test** softkey and select the **Device Full Speed Signal Quality** test.
- 6 Press the **Settings** softkey. In the USB Signal Quality Settings Menu:
 - a Press the **D+ Source** softkey and select the analog input source channel connected to the D+ signal (channel 2 in the previous connection instructions).
 - b Press the **D- Source** softkey and select the analog input source channel connected to the D- signal (channel 3 in the previous connection instructions).

On 4-channel oscilloscopes, you are forced to use different channel pairs for the D+ and D- signals. This provides the maximum sample rate. (Channels 1 and 2 are one pair and channels 3 and 4 are the other pair.)

When full speed tests are run on a 2-channel oscilloscope, a statement about the analysis data being under-sampled will be included in the test results.

- c Press the **Adj D+ Source** softkey and select the analog input source channel connected to the adjacent D+ signal (channel 1 in the previous connection instructions).
- 7 Press the **Auto Setup** softkey to automatically set up the oscilloscope for the selected test.

For optimal test results, you can make adjustments to the auto setup. Generally, you want one packet of data, plus the time of one bit on each end, across the oscilloscope's display. Also, vertical scale and offset should be adjusted so that the signals take six vertical divisions without being clipped.

You should see the transmitted test packet on the oscilloscope as below.

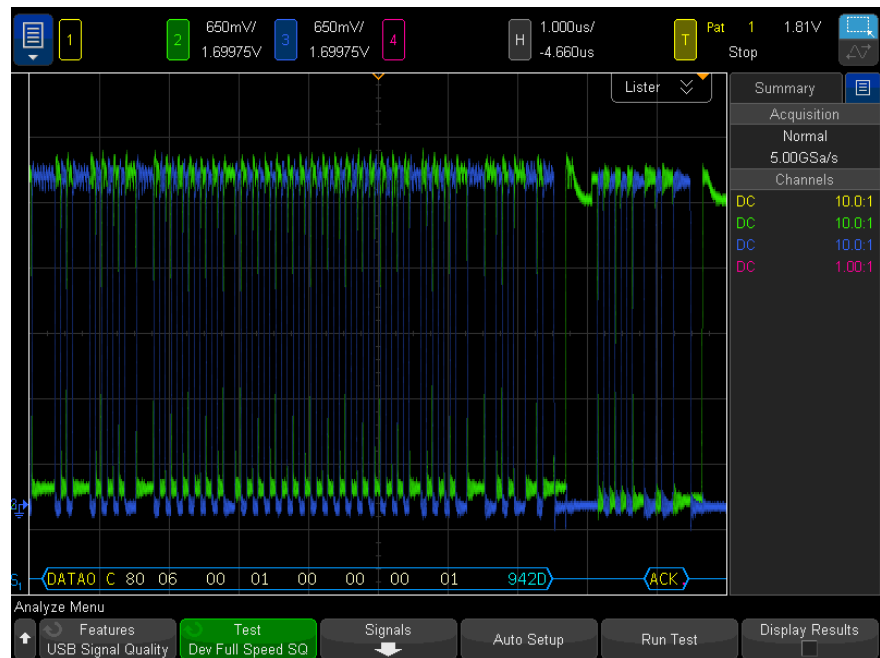

- 8 Press the **Run Test** softkey to run the selected signal quality test.

When tests are run, the oscilloscope stops acquisitions if they are running, analyzes the data on screen, and then displays the results.

NOTE

Tests can take several minutes to run and cannot be cancelled once started.

When the test completes, the results are automatically displayed. You can press the **Display Results** softkey to disable or reenable the test results display.

The analyzed acquisition remains on screen and can be viewed by moving or dismissing the results dialog box.

You can run tests when the oscilloscope is already stopped. This is useful in the case of embedded hosts (and other cases) where the device under test (DUT) may not easily be placed in a test mode, and you want to analyze already acquired data.

See Also · [Chapter 6](#), “Saving Test Results to an HTML File,” starting on page 85

Device Full Speed Connection

Perform these connection steps:

- 1 Attach the passive probes to the oscilloscope's Channel 2, Channel 3 and Channel 1 inputs.
- 2 Attach the SQiDD board to two USB ports at the end of 5 self-powered hubs and a host system. Hub #1 has to be a hi-speed hub and hub #2 has to be a full speed hub. The rest of the hubs can be either hi-speed or full speed hubs.

NOTE

Placing a full speed and/or a high-speed device downstream of a full speed hub forces both to operate in full speed mode.

- 3 Attach a full speed device under test to the same section of the SQiDD board. If the section has a switch, it should be set to ON.
- 4 Attach another full speed device to the adjacent section of the SQiDD board. This is for triggering purposes.

NOTE

Use a full-speed hub if device under test has embedded hub function. Otherwise the oscilloscope will falsely trigger.

- 5 Connect the oscilloscope Channel 2 probe to D+ probe point of the device under test portion. Connect the oscilloscope Channel 3 probe to the D- probe point of the device under test portion. Connect the oscilloscope Channel 1 probe to the D+ probe point on the adjacent device section of the SQiDD board.

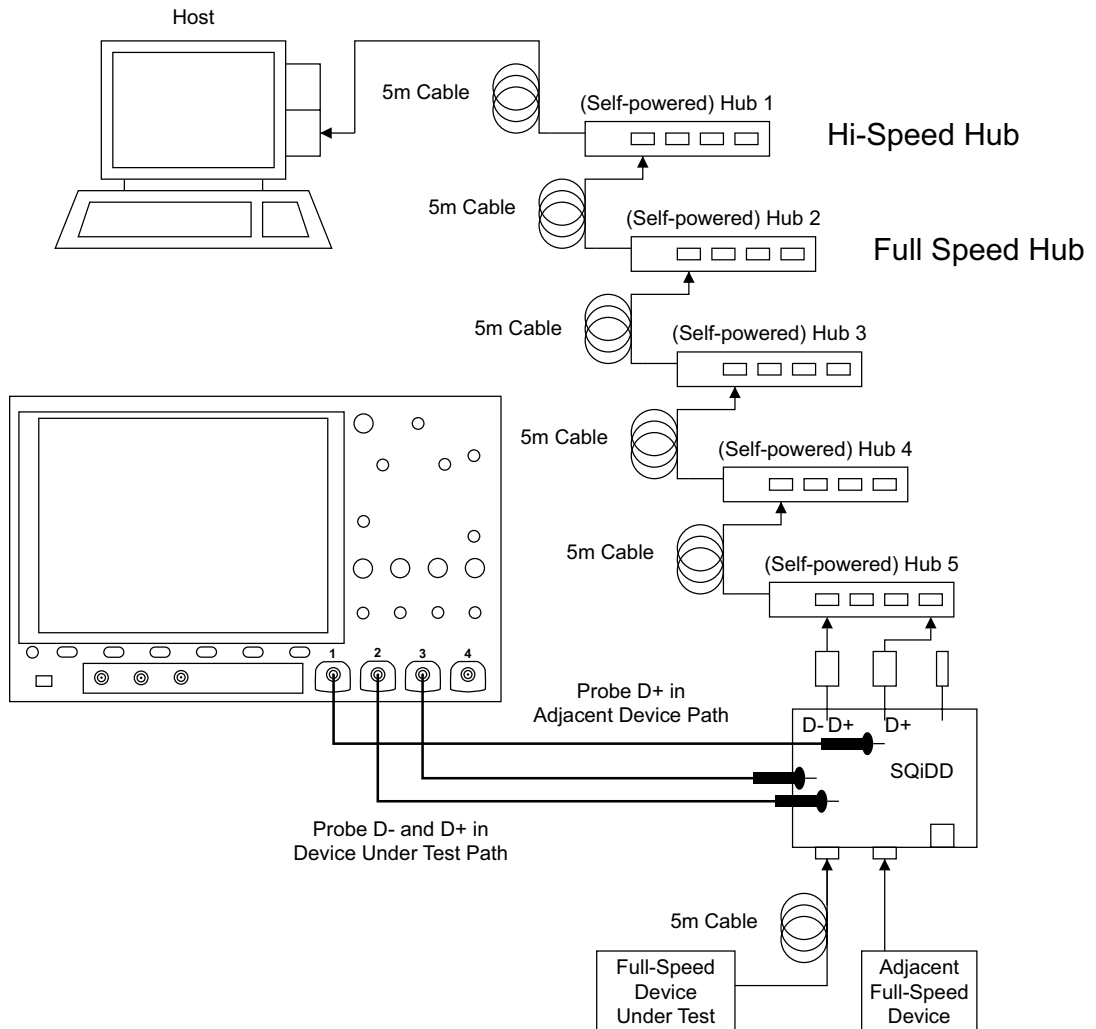

Device Full Speed Compliance Test Packets

To set up the Host computer to transmit compliance test packets, perform these steps:

- 1 Invoke the HS Electrical Test Tool software on the Hi-Speed Electrical Test Bed computer.
- 2 Select **Device** and click the **TEST** button to open the Device Test dialog box.

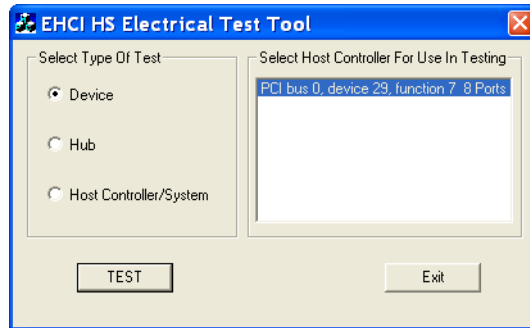

- 3 In the Device Test dialog box, click **Enumerate Bus** once.

All devices attached to the host controller should appear in the device enumeration list.

If you do not know which VID/PID belongs to the device under test, detach the device under test and enumerate the bus once. Then reattach the device under test and enumerate again, this time paying attention to the new device attached.

- 4 Highlight the device under test and select **LOOP DEVICE DESCRIPTOR** from the **Device Command** drop down menu.
- 5 Click **EXECUTE** once.

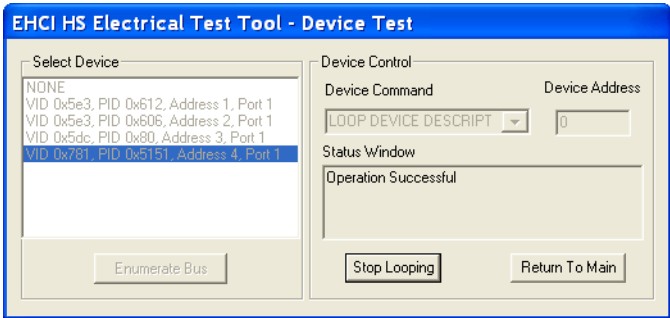

Device Low Speed Signal Quality Test

Table 5 Equipment Used in Upstream Low Speed Signal Quality Test

| Quantity | Item | Description/Model |
|----------|------------------------|--|
| 1 | Oscilloscope | Keysight 4000/6000 X-Series |
| 3 | Passive probes | Probes included with the oscilloscope are sufficient. |
| 1 | Host test bed computer | Any computer with the Windows XP, Windows 7, or Windows 8 operating system and hi-speed USB ports. |
| 1 | SQIDD board | Keysight E2646A/B |
| 1 | low speed USB device | Any USB mouse |
| 5 | USB self-powered hubs | Any listed on USB-IF web site |
| 6 | 5 meter USB cables | Any listed on USB-IF web site |

To set up and run the Device Low Speed signal quality tests:

- 1 Connect the USB Device, test fixtures, and equipment. See **“Device Low Speed Connection”** on page 36.
- 2 Set up the test signal/packet that will be analyzed.

To set up the test packets used for compliance testing, see **“Device Low Speed Compliance Test Packets”** on page 37.

- 3 On the oscilloscope's front panel, press the **[Analyze]** key.
- 4 In the Analyze Menu, press the **Features** softkey; then, select **USB Signal Quality**.
- 5 Press the **Test** softkey and select the **Device Low Speed Signal Quality** test.
- 6 Press the **Settings** softkey. In the USB Signal Quality Settings Menu:
 - a Press the **D+ Source** softkey and select the analog input source channel connected to the D+ signal (channel 2 in the previous connection instructions).
 - b Press the **D- Source** softkey and select the analog input source channel connected to the D- signal (channel 3 in the previous connection instructions).

On 4-channel oscilloscopes, you are forced to use different channel pairs for the D+ and D- signals. This provides the maximum sample rate. (Channels 1 and 2 are one pair and channels 3 and 4 are the other pair.)

 - c Press the **Adj D- Source** softkey and select the analog input source channel connected to the adjacent D- signal (channel 1 in the previous connection instructions).
- 7 Press the **Auto Setup** softkey to automatically set up the oscilloscope for the selected test.

For optimal test results, you can make adjustments to the auto setup. Generally, you want one packet of data, plus the time of one bit on each end, across the oscilloscope's display. Also, vertical scale and offset should be adjusted so that the signals take six vertical divisions without being clipped.

You should see the transmitted test packet on the oscilloscope as below.



8 Press the **Run Test** softkey to run the selected signal quality test.

When tests are run, the oscilloscope stops acquisitions if they are running, analyzes the data on screen, and then displays the results.

NOTE

Tests can take several minutes to run and cannot be cancelled once started.

When the test completes, the results are automatically displayed. You can press the **Display Results** softkey to disable or reenale the test results display.

The analyzed acquisition remains on screen and can be viewed by moving or dismissing the results dialog box.

You can run tests when the oscilloscope is already stopped. This is useful in the case of embedded hosts (and other cases) where the device under test (DUT) may not easily be placed in a test mode, and you want to analyze already acquired data.

See Also · **Chapter 6**, “Saving Test Results to an HTML File,” starting on page 85

Device Low Speed Connection

Perform these connection steps:

- 1** Attach the passive probes to the oscilloscope's Channel 2, Channel 3 and Channel 1 inputs.
- 2** Attach the SQiDD board to two USB ports at the end of 5 self-powered hubs and a host system. Hub #1 has to be a hi-speed hub and hub #2 has to be a full speed hub. The rest of the hubs can be either hi-speed or full speed hubs.

NOTE

Placing a full speed and/or a high-speed device downstream of a full speed hub forces both to operate in full speed mode.

- 3** Attach a low speed device under test to the same section of the SQiDD board. If the section has a switch, it should be set to ON.
- 4** Attach another low speed device to the adjacent section of the SQiDD board. This is for triggering purposes.
- 5** Connect the oscilloscope Channel 2 probe to D+ probe point of the device under test portion. Connect the oscilloscope Channel 3 probe to the D- probe point of the device under test portion. Connect the oscilloscope Channel 1 probe to the D- probe point on the adjacent device section of the SQiDD board.

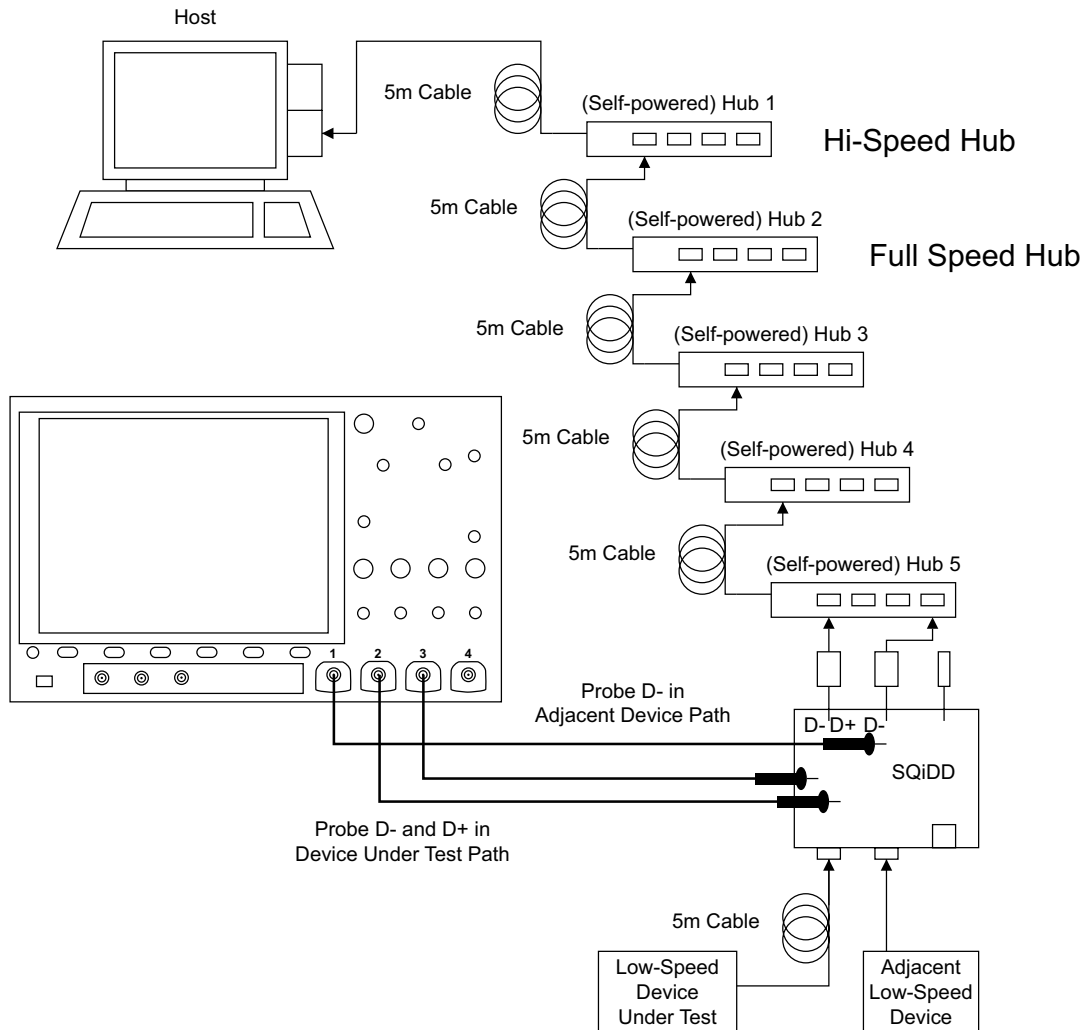

Device Low Speed Compliance Test Packets

To set up the Host computer to transmit compliance test packets, perform these steps:

- 1 Invoke the HS Electrical Test Tool software on the Hi-Speed Electrical Test Bed computer.

- 2 Select **Device** and click the **TEST** button to open the Device Test dialog box.

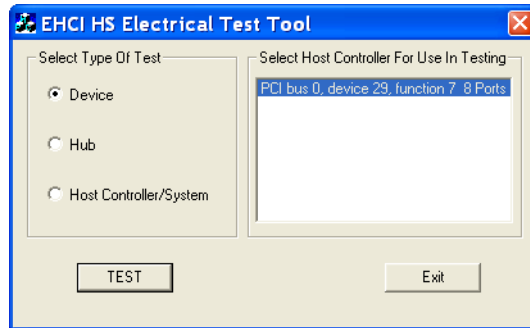

- 3 In the Device Test dialog box, click **Enumerate Bus** once.

All devices attached to the host controller should appear in the device enumeration list.

If you do not know which VID/PID belongs to the device under test, detach the device under test and enumerate the bus once. Then reattach the device under test and enumerate again, this time paying attention to the new device attached.

- 4 Highlight the device under test and select **LOOP DEVICE DESCRIPTOR** from the **Device Command** drop down menu.
- 5 Click **EXECUTE** once.

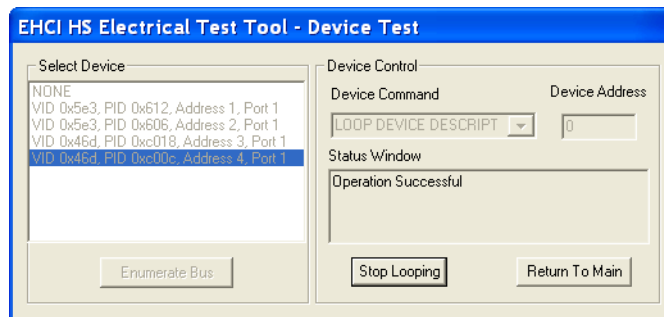

3 Host Signal Quality Testing

Host Hi-Speed Signal Quality Test / 39
Host Full Speed Signal Quality Test / 45
Host Low Speed Signal Quality Test / 50

Host Hi-Speed Signal Quality Test

Table 6 Equipment Used in Host Hi-Speed Signal Quality Tests

| Quantity | Item | Description/Model |
|----------|--|--|
| 1 | Oscilloscope | Keysight 4000/6000 X-Series >1.5 GHz band width model |
| 1 | Oscilloscope probing solution: | |
| | ▪ Differential probe | Keysight 113xA with E2678A or E2669A |
| | ▪ SMA cables | Keysight 15443A matched cable pair or equivalent |
| 1 | Host test bed computer | Any computer with the Windows XP, Windows 7, or Windows 8 operating system and hi-speed USB ports. |
| 1 | Host Hi-Speed Signal Quality test fixture and 4" USB cable | Keysight E2649-66402 |
| 1 | 5V power supply | Keysight 0950-2546 or equivalent |

To set up and run the Host Hi-Speed signal quality tests:

- 1 Connect the USB Device, test fixtures, and equipment:
 - If you are probing the test fixture using a differential probe, see "**Host Hi-Speed Connection - Differential Probe**" on page 42.

- If you are probing the test fixture using SMA cables, see “**Host Hi-Speed Connection - SMA Cables**” on page 43.
- 2 Set up the test signal/packet that will be analyzed.
To set up the test packets used for compliance testing, see “**Host Hi-Speed Compliance Test Packets**” on page 44.
- 3 On the oscilloscope's front panel, press the **[Analyze]** key.
- 4 In the Analyze Menu, press the **Features** softkey; then, select **USB Signal Quality**.
- 5 Press the **Test** softkey and select the **Host Hi-Speed Signal Quality** test.
- 6 Press the **Settings** softkey. In the USB Signal Quality Settings Menu:
 - a Press the **Test Connection** softkey and select whether you are using a **Single-ended** (with SMA cables) or **Differential** probe connection.
 - b If you are using a differential connection, press the **Source** softkey and select the analog input source channel connected to the differential probe.

If you are using a single-ended (SMA cables) connection, press the **DP SMA** softkey and select the analog input source channel connected to the D+ signal. Then, press the **DN SMA** softkey and select the analog input source channel connected to the D- signal.

On 4-channel oscilloscopes, you are forced to use different channel pairs for the D+ and D- signals. This provides the maximum sample rate. (Channels 1 and 2 are one pair and channels 3 and 4 are the other pair.)

Hi-Speed tests using single-ended SMA cable connections are not supported on 2-channel oscilloscopes because the sample rate does not meet the required 5 GSa/s.

- c Press the **Test Type** softkey and select **Near-end** or **Far-end**.
The terms "near-end" and "far-end" are based on which end of the cable the test fixture is attached in relation to the device being tested. The point where measurements are made dictates what eye template is used.
- d Press the **Number of Hubs** softkey and specify the number of internal hubs between the host and the test point.

When the Near-end test type is selected, you can specify 0 to 5 hubs.

When the Far-end test type is selected, the number of hubs is set to 0.

The specified number of hubs affects the test limits for the Sync results and the EOP Width results.

- 7 Press the **Auto Setup** softkey to automatically set up the oscilloscope for the selected test.

For optimal test results, you can make adjustments to the auto setup. Generally, you want one packet of data, plus the time of one bit on each end, across the oscilloscope's display. Also, vertical scale and offset should be adjusted so that the signals take six vertical divisions without being clipped.

You should see the transmitted test packet on the oscilloscope as below.



- 8 Press the **Run Test** softkey to run the selected signal quality test.

When tests are run, the oscilloscope stops acquisitions if they are running, analyzes the data on screen, and then displays the results.

NOTE

Tests can take several minutes to run and cannot be cancelled once started.

When the test completes, the results are automatically displayed. You can press the **Display Results** softkey to disable or reenable the test results display.

The analyzed acquisition remains on screen and can be viewed by moving or dismissing the results dialog box.

You can run tests when the oscilloscope is already stopped. This is useful in the case of embedded hosts (and other cases) where the device under test (DUT) may not easily be placed in a test mode, and you want to analyze already acquired data.

See Also · **Chapter 6**, “Saving Test Results to an HTML File,” starting on page 85

Host Hi-Speed Connection - Differential Probe

Perform these connection steps:

- 1** Attach the 5V power supply to J5 of the E2649-66402 Host Hi-Speed Signal Quality test fixture and verify the green POWER LED is lit.
 - a** Set the TEST switch (S1) of the test fixture to the ON position and verify the yellow TEST LED is lit.
- 2** Attach the Keysight 113xA differential probe to TP2 of the test fixture. Ensure the + polarity on the probe lines up with D+, which is the pin nearest the USB connector.
- 3** Please terminate the fixture's SMA connectors with 50 Ohm terminators.

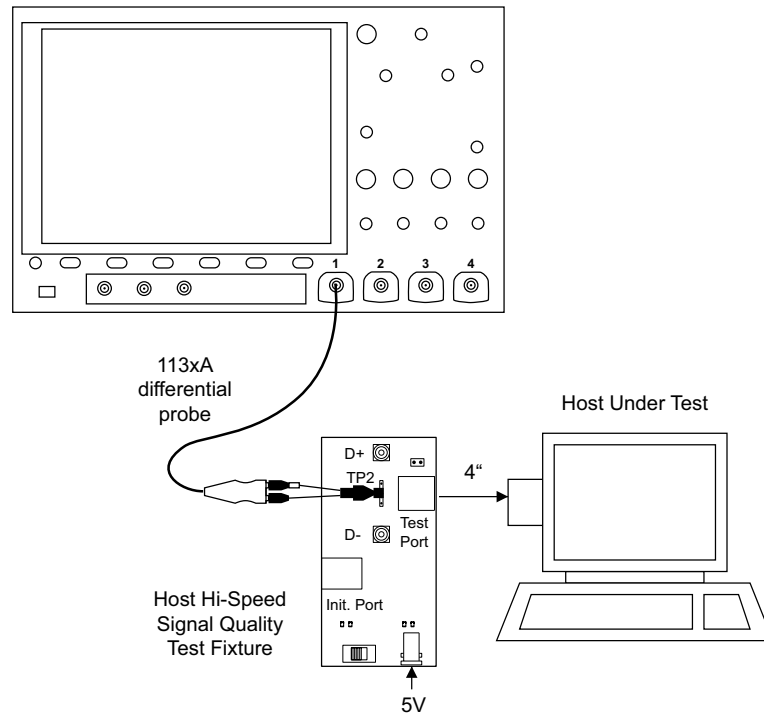

- 4 Connect the [TEST PORT] of the E2649-66402 Host Hi-Speed Signal Quality test fixture into the port under test of the host controller, using the 4" USB cable.

The host controller here refers to the Hi-speed Electrical Test Bed Computer that has the HS Electrical Test Tool on it.

Host Hi-Speed Connection - SMA Cables

- 1 Attach the 5V power supply to J5 of the E2649-66402 Hi-Speed signal quality test fixture. Verify the green POWER LED is lit.
- 2 Set the TEST switch (S1) of the test fixture to the ON position and verify that the yellow TEST LED is lit.
- 3 Attach the SMA cables to SMA connectors D+ and D- on the test fixture.

3 Host Signal Quality Testing

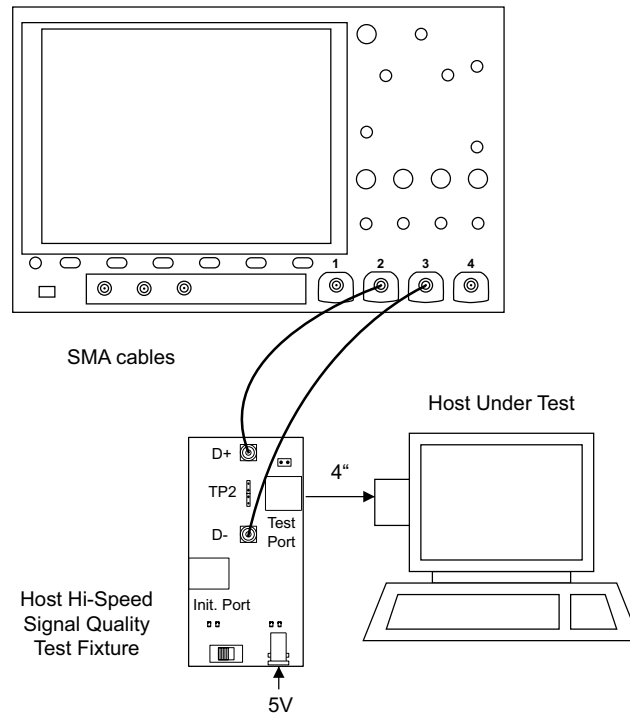

- 4 Connect the [TEST PORT] of the E2649-66402 Host Hi-Speed Signal Quality test fixture into the port under test of the host controller, using the 4" USB cable.

The host controller here refers to the Hi-speed Electrical Test Bed Computer that has the HS Electrical Test Tool on it.

Host Hi-Speed Compliance Test Packets

To set up the Host computer to transmit compliance test packets, perform these steps:

- 1 Invoke the HS Electrical Test Tool software on the Hi-Speed Electrical Test Bed computer.
- 2 Select **Host Controller/System** and click the **TEST** button to open the Host Test dialog box.

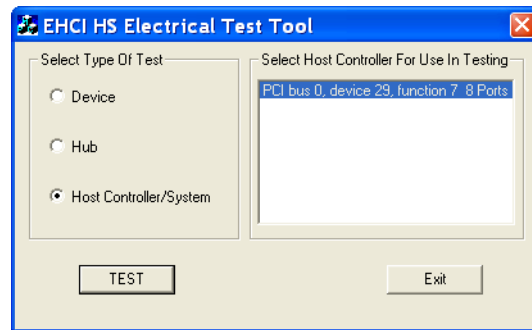

- 3 In the Host Test dialog box, select **TEST_PACKET** from the **Port Control** drop down menu.
- 4 Enter the port number of the port under test.
- 5 Click **EXECUTE**.

This forces the port under test to continuously transmit test packets.

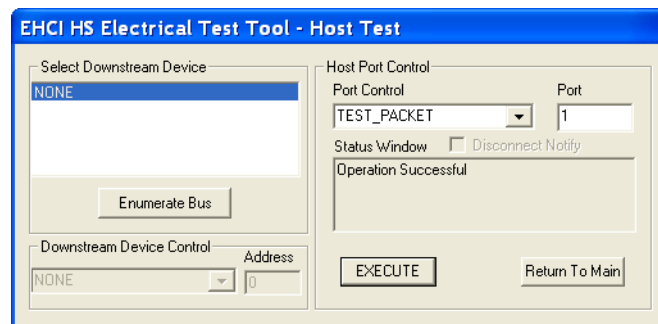

Host Full Speed Signal Quality Test

Table 7 Equipment Used in Host Downstream Full Speed Signal Quality Test

| Quantity | Item | Description/Model |
|----------|--------------|-----------------------------|
| 1 | Oscilloscope | Keysight 4000/6000 X-Series |

Table 7 Equipment Used in Host Downstream Full Speed Signal Quality Test (continued)

| Quantity | Item | Description/Model |
|----------|------------------------|--|
| 2 | Passive probes | Probes included with the oscilloscope are sufficient. |
| 1 | Host test bed computer | Any computer with the Windows XP, Windows 7, or Windows 8 operating system and hi-speed USB ports. |
| 1 | SQiDD board | Keysight E2646A/B |
| 1 | full speed USB device | Intel Create and Share USB camera, P/N 735147-001, Model #: CS330 |
| 5 | USB self-powered hubs | Any listed on USB-IF web site |
| 6 | 5 meter USB cables | Any listed on USB-IF web site |

To set up and run the Host Full Speed signal quality tests:

- 1 Connect the USB Device, test fixtures, and equipment. See "**Host Full Speed Connection**" on page 48.
- 2 Set up the test signal/packet that will be analyzed.

To generate bus traffic, connect a known good Full Speed device to the port under test and capture the Full Speed SOF to perform the eye pattern analysis.

- 3 On the oscilloscope's front panel, press the **[Analyze]** key.
- 4 In the Analyze Menu, press the **Features** softkey; then, select **USB Signal Quality**.
- 5 Press the **Test** softkey and select the **Host Full Speed Signal Quality** test.
- 6 Press the **Settings** softkey. In the USB Signal Quality Settings Menu:
 - a Press the **D+ Source** softkey and select the analog input source channel connected to the D+ signal (channel 2 in the previous connection instructions).
 - b Press the **D- Source** softkey and select the analog input source channel connected to the D- signal (channel 3 in the previous connection instructions).

On 4-channel oscilloscopes, you are forced to use different channel pairs for the D+ and D- signals. This provides the maximum sample rate. (Channels 1 and 2 are one pair and channels 3 and 4 are the other pair.)

When full speed tests are run on a 2-channel oscilloscope, a statement about the analysis data being under-sampled will be included in the test results.

- 7 Press the **Auto Setup** softkey to automatically set up the oscilloscope for the selected test.

For optimal test results, you can make adjustments to the auto setup. Generally, you want one packet of data, plus the time of one bit on each end, across the oscilloscope's display. Also, vertical scale and offset should be adjusted so that the signals take six vertical divisions without being clipped.

You should see the transmitted test packet on the oscilloscope as below.

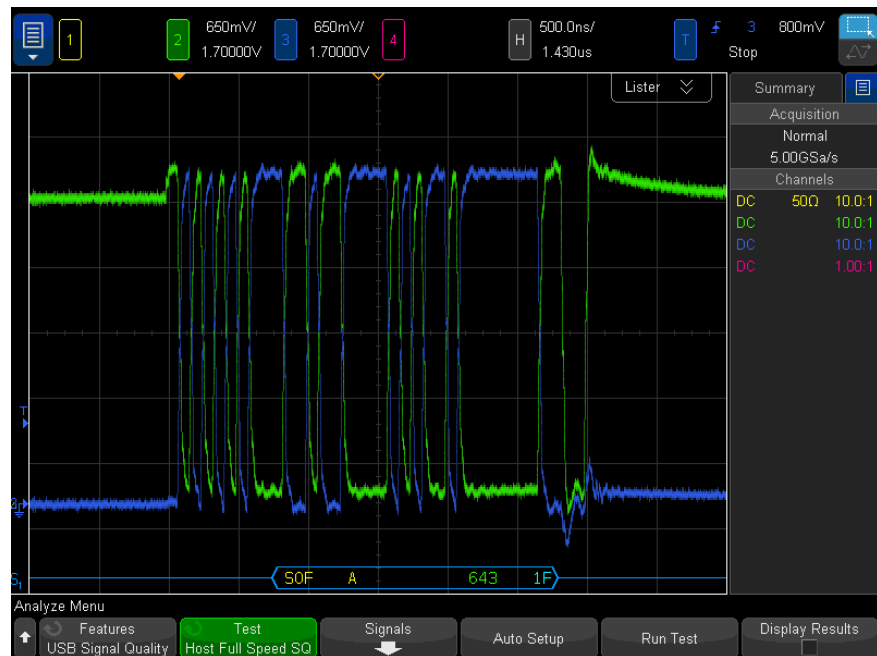

- 8 Press the **Run Test** softkey to run the selected signal quality test.

When tests are run, the oscilloscope stops acquisitions if they are running, analyzes the data on screen, and then displays the results.

NOTE

Tests can take several minutes to run and cannot be cancelled once started.

When the test completes, the results are automatically displayed. You can press the **Display Results** softkey to disable or reenable the test results display.

The analyzed acquisition remains on screen and can be viewed by moving or dismissing the results dialog box.

You can run tests when the oscilloscope is already stopped. This is useful in the case of embedded hosts (and other cases) where the device under test (DUT) may not easily be placed in a test mode, and you want to analyze already acquired data.

See Also · [Chapter 6](#), “Saving Test Results to an HTML File,” starting on page 85

Host Full Speed Connection

Perform these connection steps:

- 1 Attach the passive probes to the oscilloscope's Channel 3 and Channel 2 inputs.
- 2 Attach the SQiDD board to the root hub on the host under test.
- 3 Attach 5 self-powered hubs and a full-speed device to the same section of the SQiDD board. If the section has a switch, it should be set to ON. Hub #1 has to be a full-speed hub and hub #2 a Hi-speed hub. The other hubs can be either full speed or hi-speed hubs.

NOTE

Placing a full speed and/or a high-speed device downstream of a full speed hub forces both to operate in full speed mode.

- 4 Connect the oscilloscope Channel 2 probe to D+ probe point of the device under test portion. Connect the oscilloscope Channel 3 probe to the D- probe point of the device under test portion.
- 5 Exit the HS Electrical Test Tool if you have previously launched.

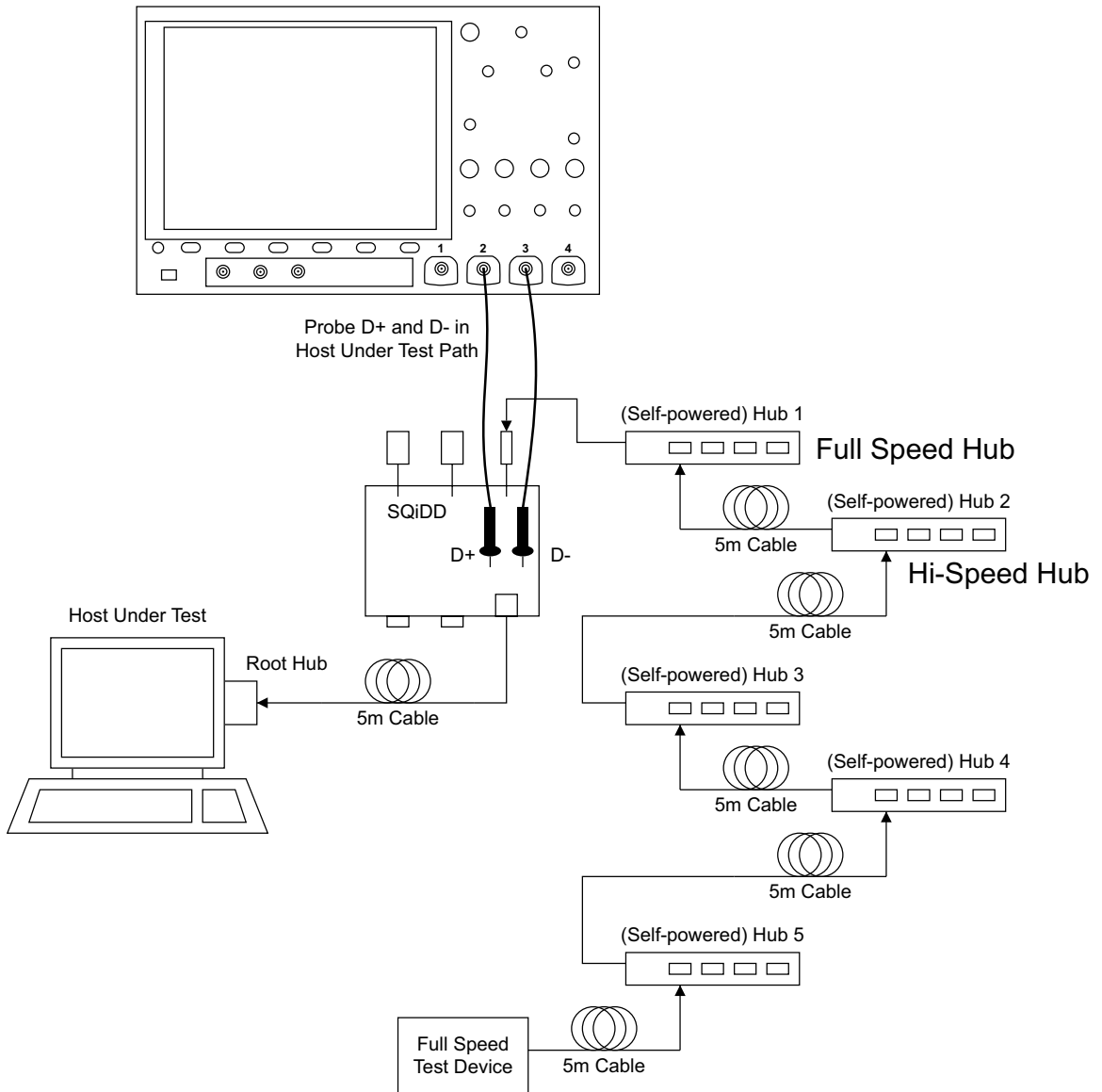

Host Low Speed Signal Quality Test

Table 8 Equipment Used in Host Downstream Low Speed Signal Quality Test

| Quantity | Item | Description/Model |
|----------|------------------------|--|
| 1 | Oscilloscope | Keysight 4000/6000 X-Series |
| 2 | Passive probes | Probes included with the oscilloscope are sufficient. |
| 1 | Host test bed computer | Any computer with the Windows XP, Windows 7, or Windows 8 operating system and hi-speed USB ports. |
| 1 | SQiDD board | Keysight E2646A/B |
| 1 | low speed USB device | Any USB mouse |

To set up and run the Host Low Speed signal quality tests:

- 1 Connect the USB Device, test fixtures, and equipment. See “**Host Low Speed Connection**” on page 52.
- 2 Set up the test signal/packet that will be analyzed.

To generate bus traffic, connect a known good Low Speed device to the port under test and capture a Low Speed packet to perform the eye pattern analysis.
- 3 On the oscilloscope's front panel, press the **[Analyze]** key.
- 4 In the Analyze Menu, press the **Features** softkey; then, select **USB Signal Quality**.
- 5 Press the **Test** softkey and select the **Host Low Speed Signal Quality** test.
- 6 Press the **Settings** softkey. In the USB Signal Quality Settings Menu:
 - a Press the **D+ Source** softkey and select the analog input source channel connected to the D+ signal (channel 2 in the previous connection instructions).
 - b Press the **D- Source** softkey and select the analog input source channel connected to the D- signal (channel 3 in the previous connection instructions).

On 4-channel oscilloscopes, you are forced to use different channel pairs for the D+ and D- signals. This provides the maximum sample rate. (Channels 1 and 2 are one pair and channels 3 and 4 are the other pair.)

- Press the **Auto Setup** softkey to automatically set up the oscilloscope for the selected test.

For optimal test results, you can make adjustments to the auto setup. Generally, you want one packet of data, plus the time of one bit on each end, across the oscilloscope's display. Also, vertical scale and offset should be adjusted so that the signals take six vertical divisions without being clipped.

You should see the transmitted test packet on the oscilloscope as below.



- Press the **Run Test** softkey to run the selected signal quality test.

When tests are run, the oscilloscope stops acquisitions if they are running, analyzes the data on screen, and then displays the results.

NOTE

Tests can take several minutes to run and cannot be cancelled once started.

When the test completes, the results are automatically displayed. You can press the **Display Results** softkey to disable or reenabte the test results display.

The analyzed acquisition remains on screen and can be viewed by moving or dismissing the results dialog box.

You can run tests when the oscilloscope is already stopped. This is useful in the case of embedded hosts (and other cases) where the device under test (DUT) may not easily be placed in a test mode, and you want to analyze already acquired data.

See Also · [Chapter 6](#), “Saving Test Results to an HTML File,” starting on page 85

Host Low Speed Connection

Perform these connection steps:

- 1 Use the passive probes included with the oscilloscope.
- 2 Attach the passive probes to the oscilloscope's Channel 3 and Channel 2 inputs.
- 3 Attach the SQiDD board to the root hub on the host under test.
- 4 Attach a low speed device to the same section of the SQiDD board. If the section has a switch, it should be set to ON.
- 5 Connect the oscilloscope Channel 2 probe to D+ probe point on the SQiDD board. Connect the oscilloscope Channel 3 probe to the D- probe point on the SQiDD board.
- 6 Exit the HS Electrical Test Tool if you have previously launched it.

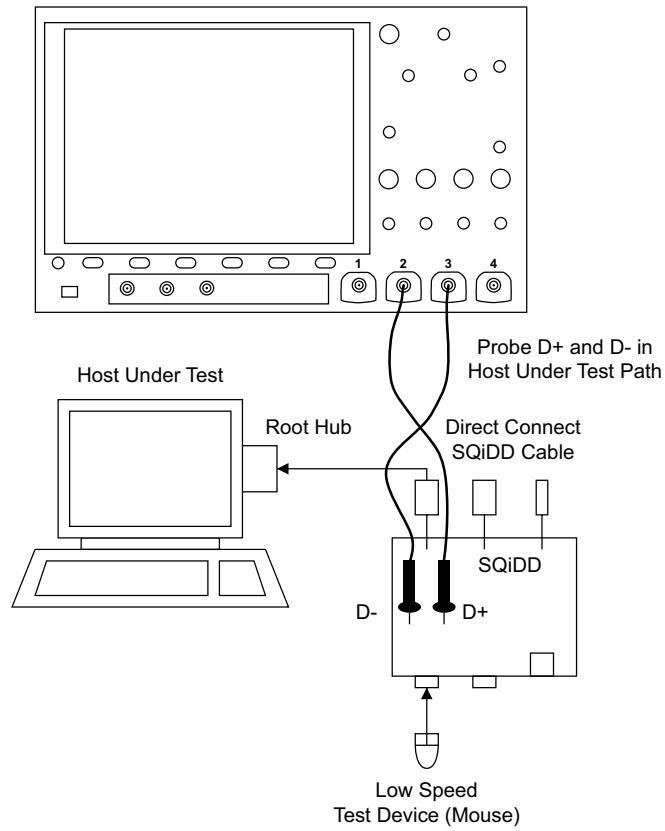

4 Hub Upstream Signal Quality Testing

Hub Upstream Hi-Speed Signal Quality Test / 55
Hub Upstream Full Speed Signal Quality Test / 61

Hub Upstream Hi-Speed Signal Quality Test

Table 9 Equipment Used in Hub Hi-Speed Signal Quality Test - Upstream Facing Ports

| Quantity | Item | Description/Model |
|----------|--|--|
| 1 | Oscilloscope | Keysight 4000/6000 X-Series >1.5 GHz bandwidth model |
| 1 | Oscilloscope probing solution: | |
| | ▪ Differential probe | Keysight 113xA with E2678A or E2669A |
| | ▪ SMA cables | Keysight 15443A matched cable pair or equivalent |
| 1 | Host test bed computer | Any computer with the Windows XP, Windows 7, or Windows 8 operating system and hi-speed USB ports. |
| 1 | Device Hi-Speed Signal Quality test fixture and 4" USB cable | Keysight E2649-66401 |
| 1 | 5V power supply | Keysight 0950-2546 or equivalent |

To set up and run the Hub upstream Hi-Speed signal quality tests:

- 1 Connect the USB Device, test fixtures, and equipment:

- If you are probing the test fixture using a differential probe, see "**Hub Upstream Hi-Speed Connection - Differential Probe**" on page 58.
- If you are probing the test fixture using SMA cables, see "**Hub Upstream Hi-Speed Connection - SMA Cables**" on page 59.

2 Set up the test signal/packet that will be analyzed.

To set up the test packets used for compliance testing, see "**Hub Upstream Hi-Speed Compliance Test Packets**" on page 60.

3 On the Device Hi-Speed Signal Quality test fixture, place the TEST switch (S1) in the ON position.

Verify the yellow TEST LED is lit.

4 On the oscilloscope's front panel, press the **[Analyze]** key.

5 In the Analyze Menu, press the **Features** softkey; then, select **USB Signal Quality**.

6 Press the **Test** softkey and select the **Device Hi-Speed Signal Quality** test.

7 Press the **Settings** softkey. In the USB Signal Quality Settings Menu:

- a Press the **Test Connection** softkey and select whether you are using a **Single-ended** (with SMA cables) or **Differential** probe connection.
- b If you are using a differential connection, press the **Source** softkey and select the analog input source channel connected to the differential probe.

If you are using a single-ended (SMA cables) connection, press the **DP SMA** softkey and select the analog input source channel connected to the D+ signal. Then, press the **DN SMA** softkey and select the analog input source channel connected to the D- signal.

On 4-channel oscilloscopes, you are forced to use different channel pairs for the D+ and D- signals. This provides the maximum sample rate. (Channels 1 and 2 are one pair and channels 3 and 4 are the other pair.)

Hi-Speed tests using single-ended SMA cable connections are not supported on 2-channel oscilloscopes because the sample rate does not meet the required 5 GSa/s.

- c Press the **Test Type** softkey and select **Near-end** or **Far-end**.

The terms "near-end" and "far-end" are based on which end of the cable the test fixture is attached in relation to the device being tested. The point where measurements are made dictates what eye template is used.

8 Press the **Auto Setup** softkey to automatically set up the oscilloscope for the selected test.

For optimal test results, you can make adjustments to the auto setup. Generally, you want one packet of data, plus the time of one bit on each end, across the oscilloscope's display. Also, vertical scale and offset should be adjusted so that the signals take six vertical divisions without being clipped.

You should see the transmitted test packet on the oscilloscope as below.

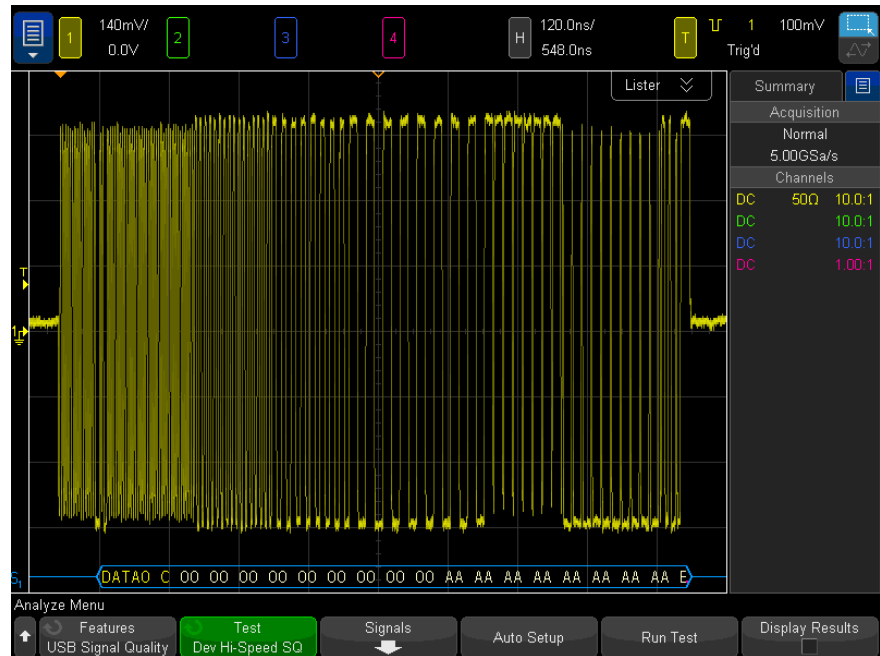

- 9 Press the **Run Test** softkey to run the selected signal quality test.

When tests are run, the oscilloscope stops acquisitions if they are running, analyzes the data on screen, and then displays the results.

NOTE

Tests can take several minutes to run and cannot be cancelled once started.

When the test completes, the results are automatically displayed. You can press the **Display Results** softkey to disable or reenble the test results display.

The analyzed acquisition remains on screen and can be viewed by moving or dismissing the results dialog box.

You can run tests when the oscilloscope is already stopped. This is useful in the case of embedded hosts (and other cases) where the device under test (DUT) may not easily be placed in a test mode, and you want to analyze already acquired data.

See Also · [Chapter 6](#), “Saving Test Results to an HTML File,” starting on page 85

Hub Upstream Hi-Speed Connection - Differential Probe

Perform these connection steps:

- 1** Attach the 5V power supply to J5 of the E2649-66401 Device Hi-Speed Signal Quality test fixture.

Leave the TEST switch at the OFF position.

Verify green POWER LED is lit, and yellow TEST LED is off.

- 2** Connect the [TEST PORT] of the test fixture into the upstream facing port of the hub under test, using the 4" USB cable.
- 3** Connect the [INIT PORT] of the test fixture to a hi-speed port of the Test Bed Computer. Apply power to the hub.
- 4** Attach the Keysight 113xA differential probe to D+/D- of TP2 on the test fixture. Ensure the + polarity on the probe lines up with D+ on the fixture.
- 5** Please terminate the fixture's SMA connectors with 50 Ohm terminators.

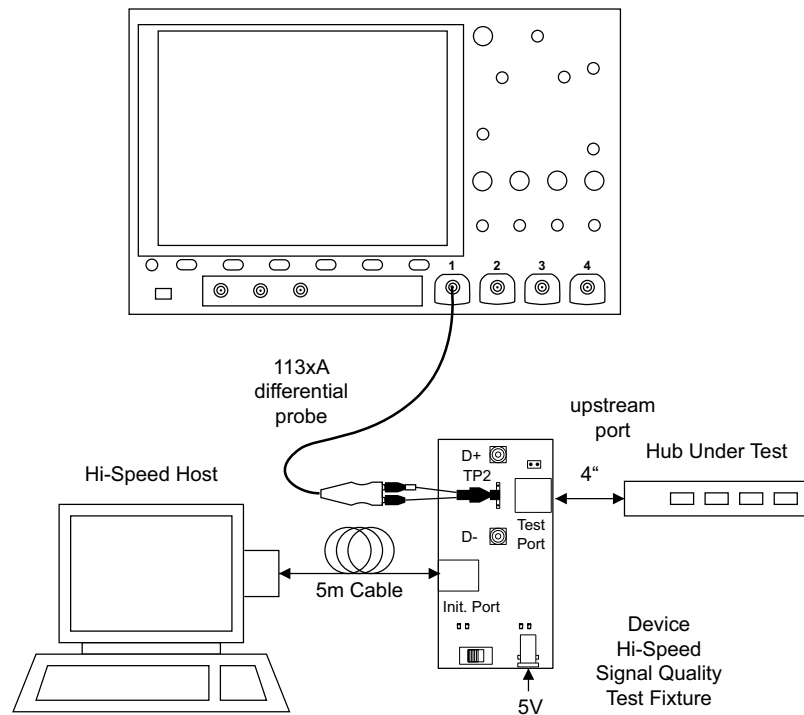

Hub Upstream Hi-Speed Connection - SMA Cables

- 1 Attach the 5V power supply to J5 of the E2649-66401 Device Hi-Speed signal quality test fixture.
 Leave the TEST switch at the OFF position.
 Verify the green POWER LED is lit and the yellow TEST LED is not lit.
- 2 Connect the [TEST PORT] of the Device Hi-speed Signal Quality test fixture into the upstream facing port of the device under test, using the 4" USB cable.
- 3 Connect the [INIT PORT] of the test fixture to a Hi-speed capable port of the Test Bed Computer, using the 5 meter USB cable.
- 4 Apply power to the device.
- 5 Attach the SMA cables to the SMA connectors D+ and D- of TP2 on the test fixture.

4 Hub Upstream Signal Quality Testing

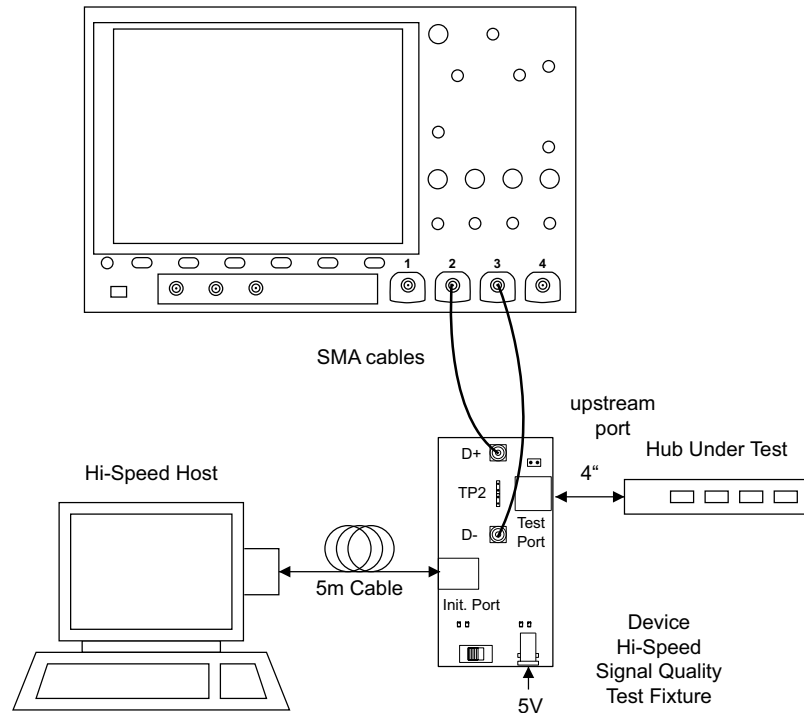

Hub Upstream Hi-Speed Compliance Test Packets

To set up the Host computer to transmit compliance test packets, perform these steps:

- 1 Invoke the HS Electrical Test Tool software on the Hi-Speed Electrical Test Bed computer. Select **Hub** and click the **TEST** button to enter the Hub Test dialog box.

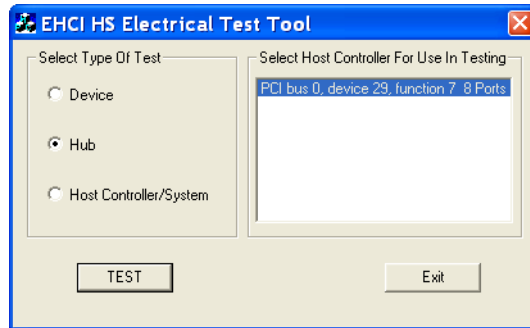

- 2 In the Hub Test dialog box, the hub under test should be enumerated with the hub's VID shown together with the USB address.

Select **TEST_PACKET** from the **Hub Command** drop down menu.

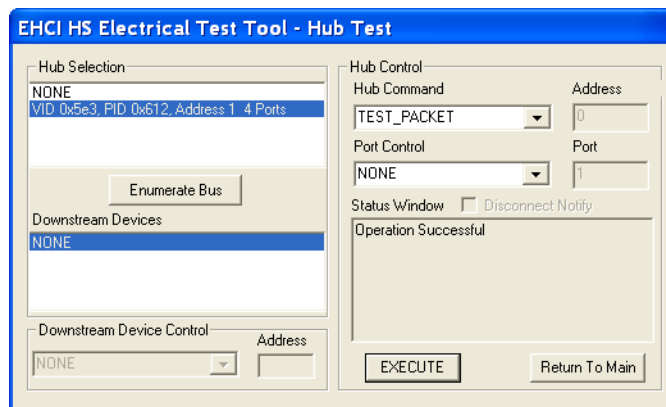

- 3 Click **EXECUTE**.

Hub Upstream Full Speed Signal Quality Test

Table 10 Equipment Used in Upstream Full Speed Signal Quality Test

| Quantity | Item | Description/Model |
|----------|--------------|-----------------------------|
| 1 | Oscilloscope | Keysight 4000/6000 X-Series |

Table 10 Equipment Used in Upstream Full Speed Signal Quality Test (continued)

| Quantity | Item | Description/Model |
|----------|------------------------|--|
| 3 | Passive probes | Probes included with the oscilloscope are sufficient. |
| 1 | Host test bed computer | Any computer with the Windows XP, Windows 7, or Windows 8 operating system and hi-speed USB ports. |
| 1 | SQiDD board | Keysight E2646A/B |
| 1 | full speed USB device | Intel Create and Share USB camera, P/N 735147-001, Model #: CS330 |
| 5 | USB self-powered hubs | Any listed on USB-IF web site |
| 6 | 5 meter USB cables | Any listed on USB-IF web site |

To set up and run the Hub upstream Full Speed signal quality tests:

- 1 Connect the USB Device, test fixtures, and equipment. See **"Hub Upstream Full Speed Connection"** on page 64.
- 2 Set up the test signal/packet that will be analyzed.

To set up the test packets used for compliance testing, see **"Hub Upstream Full Speed Compliance Test Packets"** on page 66.

- 3 On the oscilloscope's front panel, press the **[Analyze]** key.
- 4 In the Analyze Menu, press the **Features** softkey; then, select **USB Signal Quality**.
- 5 Press the **Test** softkey and select the **Device Full Speed Signal Quality** test.
- 6 Press the **Settings** softkey. In the USB Signal Quality Settings Menu:
 - a Press the **D+ Source** softkey and select the analog input source channel connected to the D+ signal (channel 2 in the previous connection instructions).
 - b Press the **D- Source** softkey and select the analog input source channel connected to the D- signal (channel 3 in the previous connection instructions).

On 4-channel oscilloscopes, you are forced to use different channel pairs for the D+ and D- signals. This provides the maximum sample rate. (Channels 1 and 2 are one pair and channels 3 and 4 are the other pair.)

When full speed tests are run on a 2-channel oscilloscope, a statement about the analysis data being under-sampled will be included in the test results.

- c Press the **Adj D+ Source** softkey and select the analog input source channel connected to the adjacent D+ signal
- 7 Press the **Auto Setup** softkey to automatically set up the oscilloscope for the selected test.

For optimal test results, you can make adjustments to the auto setup. Generally, you want one packet of data, plus the time of one bit on each end, across the oscilloscope's display. Also, vertical scale and offset should be adjusted so that the signals take six vertical divisions without being clipped.

You should see the transmitted test packet on the oscilloscope as below.

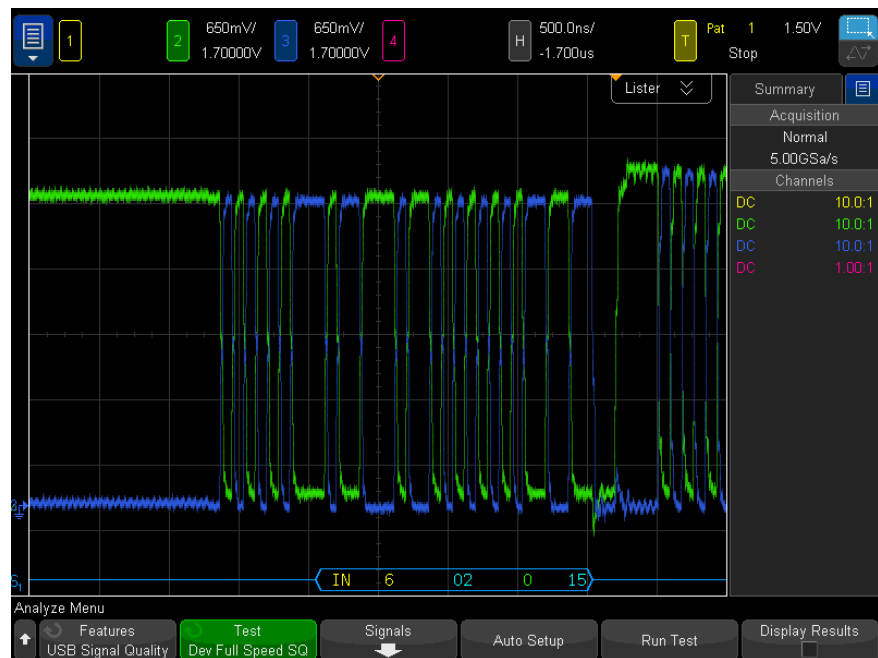

- 8 Press the **Run Test** softkey to run the selected signal quality test.

When tests are run, the oscilloscope stops acquisitions if they are running, analyzes the data on screen, and then displays the results.

NOTE

Tests can take several minutes to run and cannot be cancelled once started.

When the test completes, the results are automatically displayed. You can press the **Display Results** softkey to disable or reenable the test results display.

The analyzed acquisition remains on screen and can be viewed by moving or dismissing the results dialog box.

You can run tests when the oscilloscope is already stopped. This is useful in the case of embedded hosts (and other cases) where the device under test (DUT) may not easily be placed in a test mode, and you want to analyze already acquired data.

See Also · [Chapter 6](#), “Saving Test Results to an HTML File,” starting on page 85

Hub Upstream Full Speed Connection

Perform these connection steps:

- 1 Attach the passive probes to the oscilloscope's channel Channel 2, Channel 3 and Channel 1 inputs.
- 2 Attach the SQiDD board to two USB ports at the end of 5 self-powered hubs and a host system. Hub #1 has to be a hi-speed hub and hub #2 has to be a full speed hub. The rest of the hubs can be either hi-speed or full speed hubs.

NOTE

Placing a full speed and/or a high-speed device downstream of a full speed hub forces both to operate in full speed mode.

- 3 Attach a full speed hub under test to the same section of the SQiDD board. If the section has a switch, it should be set to ON.
- 4 Attach another full speed device to the adjacent section of the SQiDD board. This is for triggering purposes.

NOTE

Use a full-speed hub if device under test has embedded hub function. Otherwise the oscilloscope will falsely trigger.

- 5 Connect the oscilloscope Channel 2 probe to D+ probe point of the hub under test portion. Connect the oscilloscope Channel 3 probe to the D- probe point of the hub under test portion. Connect the oscilloscope Channel 1 probe to the D+ probe point on the adjacent device section of the SQiDD board.

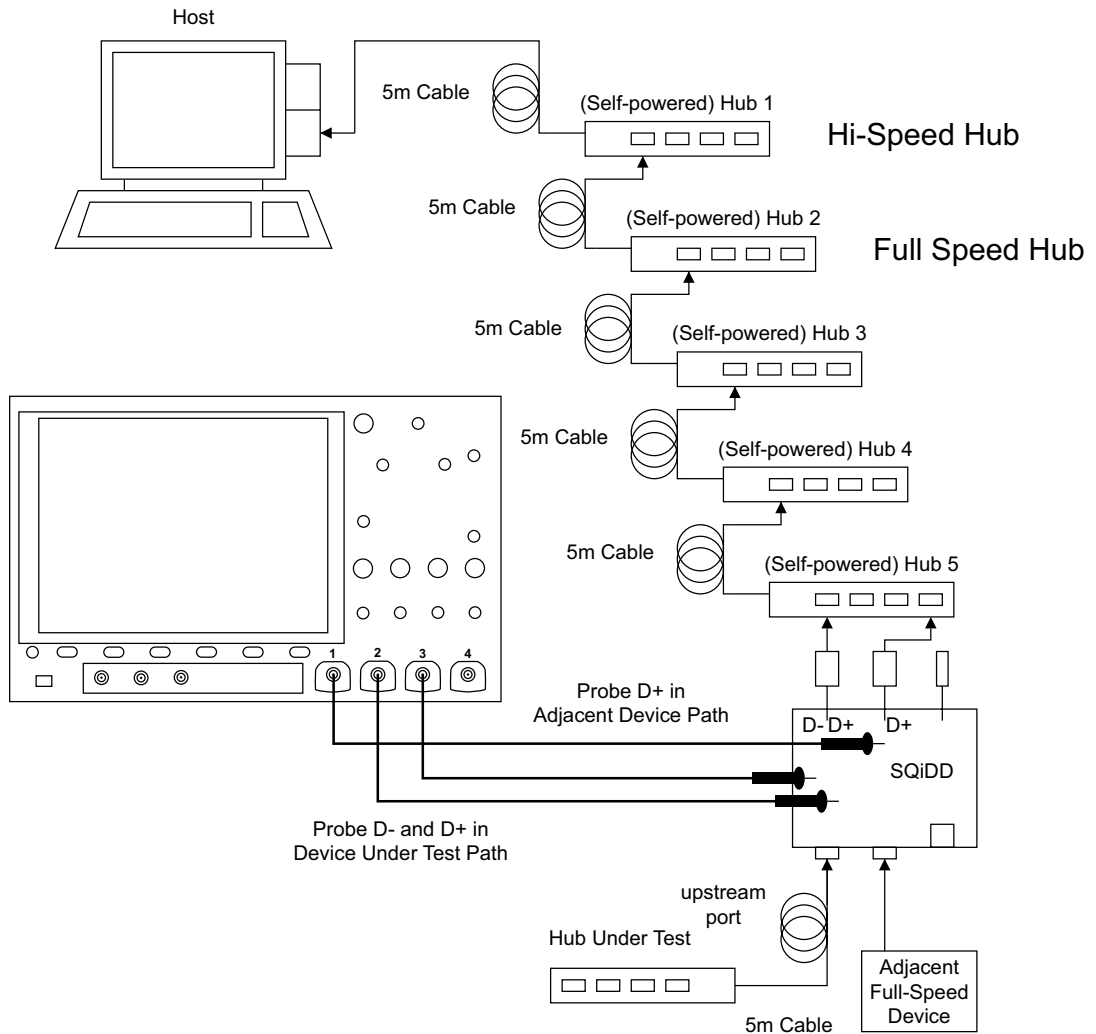

Hub Upstream Full Speed Compliance Test Packets

To set up the Host computer to transmit compliance test packets, perform these steps:

- 1 Invoke the HS Electrical Test Tool software on the Hi-Speed Electrical Test Bed computer.
- 2 Select **Device** and click the **TEST** button to open the Device Test dialog box.

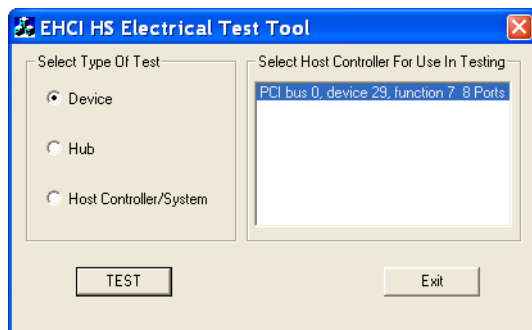

- 3 In the Device Test dialog box, click **Enumerate Bus** once.

All devices attached to the host controller should appear in the device enumeration list.

If you do not know which VID/PID belongs to the device under test, detach the device under test and enumerate the bus once. Then reattach the device under test and enumerate again, this time paying attention to the new device attached.

- 4 Highlight the hub under test and select **LOOP DEVICE DESCRIPTOR** from the **Device Command** drop down menu.
- 5 Click **EXECUTE** once.

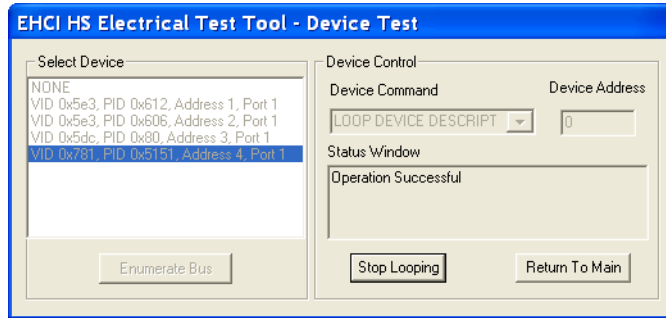

4 Hub Upstream Signal Quality Testing

5 Hub Downstream Signal Quality Testing

Hub Downstream Hi-Speed Signal Quality Test / 69

Hub Downstream Full Speed Signal Quality Test / 76

Hub Downstream Low Speed Signal Quality Test / 81

Hub Downstream Hi-Speed Signal Quality Test

Table 11 Equipment Used in Hub Hi-Speed Signal Quality Test - Downstream Facing Ports

| Quantity | Item | Description/Model |
|----------|--|--|
| 1 | Oscilloscope | Keysight 4000/6000 X-Series >1.5 GHz bandwidth model |
| 1 | Oscilloscope probing solution: | |
| | ▪ Differential probe | Keysight 113xA with E2678A or E2669A |
| | ▪ SMA cables | Keysight 15443A matched cable pair or equivalent |
| 1 | Host test bed computer | Any computer with the Windows XP, Windows 7, or Windows 8 operating system and hi-speed USB ports. |
| 1 | Host Hi-Speed Signal Quality test fixture and 4" USB cable | Keysight E2649-66402 |
| 1 | 5V power supply | Keysight 0950-2546 or equivalent |

To set up and run the Hub downstream Hi-Speed signal quality tests:

- 1 Connect the USB Device, test fixtures, and equipment:

- If you are probing the test fixture using a differential probe, see “**Hub Downstream Hi-Speed Connection - Differential Probe**” on page 72.
 - If you are probing the test fixture using SMA cables, see “**Hub Downstream Hi-Speed Connection - SMA Cables**” on page 73.
- 2 Set up the test signal/packet that will be analyzed.
To set up the test packets used for compliance testing, see “**Hub Downstream Hi-Speed Compliance Test Packets**” on page 74.
 - 3 On the oscilloscope's front panel, press the **[Analyze]** key.
 - 4 In the Analyze Menu, press the **Features** softkey; then, select **USB Signal Quality**.
 - 5 Press the **Test** softkey and select the **Host Hi-Speed Signal Quality** test.
 - 6 Press the **Settings** softkey. In the USB Signal Quality Settings Menu:
 - a Press the **Test Connection** softkey and select whether you are using a **Single-ended** (with SMA cables) or **Differential** probe connection.
 - b If you are using a differential connection, press the **Source** softkey and select the analog input source channel connected to the differential probe.

If you are using a single-ended (SMA cables) connection, press the **DP SMA** softkey and select the analog input source channel connected to the D+ signal. Then, press the **DN SMA** softkey and select the analog input source channel connected to the D- signal.

On 4-channel oscilloscopes, you are forced to use different channel pairs for the D+ and D- signals. This provides the maximum sample rate. (Channels 1 and 2 are one pair and channels 3 and 4 are the other pair.)

Hi-Speed tests using single-ended SMA cable connections are not supported on 2-channel oscilloscopes because the sample rate does not meet the required 5 GSa/s.

- c Press the **Test Type** softkey and select **Near-end** or **Far-end**.

The terms "near-end" and "far-end" are based on which end of the cable the test fixture is attached in relation to the device being tested. The point where measurements are made dictates what eye template is used.

- d Press the **Number of Hubs** softkey and specify the number of hubs between the hub being tested and the test point.

When the Near-end test type is selected, you can specify 0 to 5 hubs.

When the Far-end test type is selected, the number of hubs is set to 0.

The specified number of hubs affects the test limits for the Sync results and the EOP Width results.

- 7 Press the **Auto Setup** softkey to automatically set up the oscilloscope for the selected test.

For optimal test results, you can make adjustments to the auto setup. Generally, you want one packet of data, plus the time of one bit on each end, across the oscilloscope's display. Also, vertical scale and offset should be adjusted so that the signals take six vertical divisions without being clipped.

You should see the transmitted test packet on the oscilloscope as below.

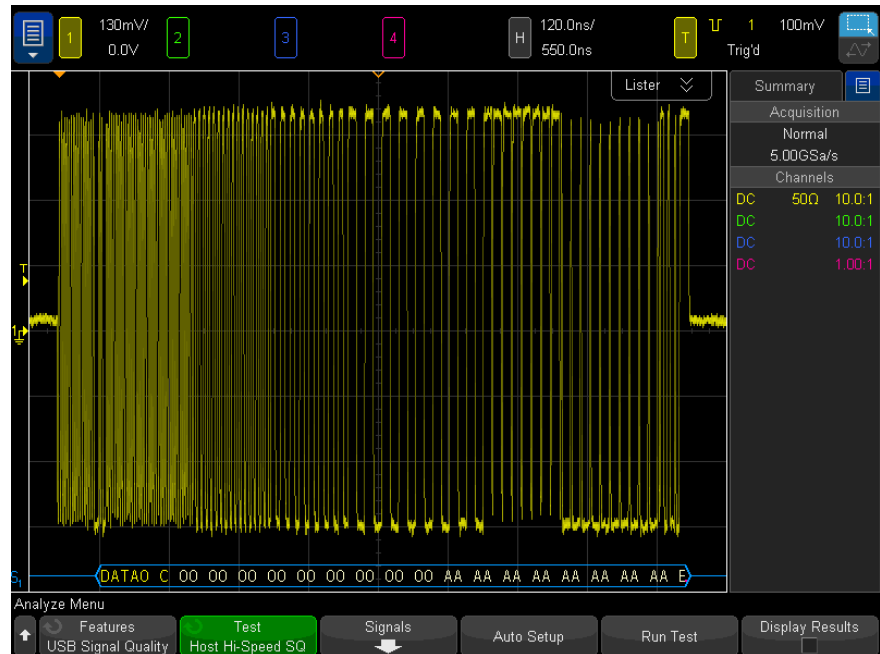

- 8 Press the **Run Test** softkey to run the selected signal quality test.

When tests are run, the oscilloscope stops acquisitions if they are running, analyzes the data on screen, and then displays the results.

NOTE

Tests can take several minutes to run and cannot be cancelled once started.

When the test completes, the results are automatically displayed. You can press the **Display Results** softkey to disable or reenable the test results display.

The analyzed acquisition remains on screen and can be viewed by moving or dismissing the results dialog box.

You can run tests when the oscilloscope is already stopped. This is useful in the case of embedded hosts (and other cases) where the device under test (DUT) may not easily be placed in a test mode, and you want to analyze already acquired data.

See Also · [Chapter 6](#), “Saving Test Results to an HTML File,” starting on page 85

Hub Downstream Hi-Speed Connection - Differential Probe

Perform these connection steps:

- 1 Attach the 5V power supply to J5 of the E2649-66402 Host Hi-Speed Signal Quality test fixture.

Set the Test switch to the TEST position.

Verify green POWER LED and yellow TEST LED are both lit.

- 2 Attach the Keysight 113xA differential probe to TP2 of the test fixture. Ensure the + polarity on the probe lines up with D+ on the fixture, located nearest to the USB connector.
- 3 Connect the upstream port of the hub to a high-speed root port of the test bed computer.
- 4 Connect the [TEST PORT] of the test fixture into the down stream facing port under the test of the hub. Apply power to the hub.
- 5 Please terminate the fixture's SMA connectors with 50 Ohm terminators.

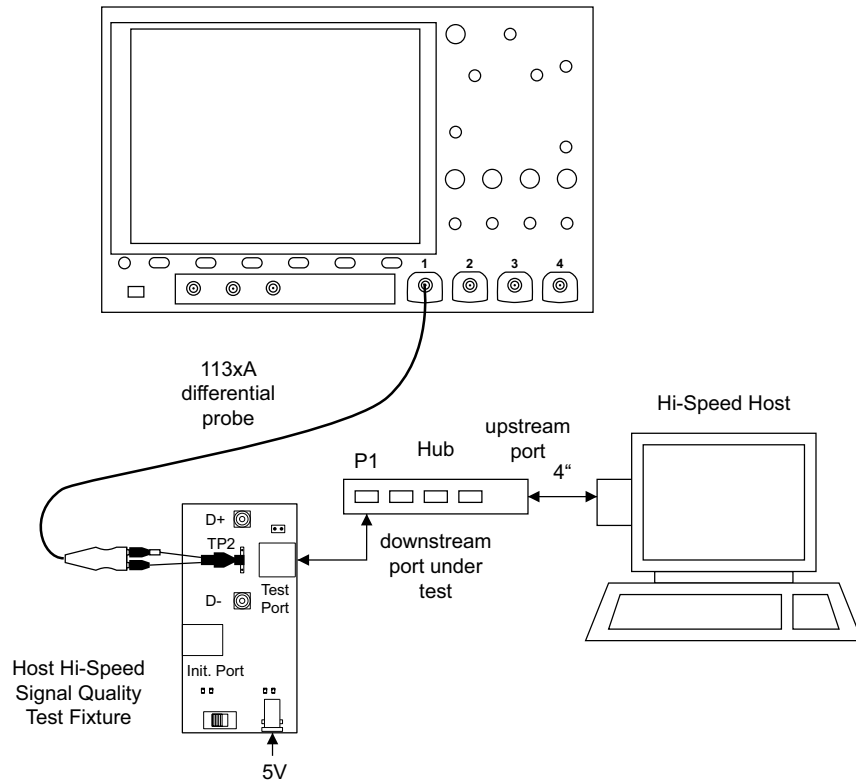

Hub Downstream Hi-Speed Connection - SMA Cables

Perform these connection steps:

- 1 Attach the 5V power supply to J5 of the E2649-66402 Host Hi-Speed Signal Quality test fixture.
Set the TEST switch to the ON position.
Verify green POWER LED and yellow TEST LED are both lit.
- 2 Connect the upstream port of the hub to a high-speed root port of the test bed computer.
- 3 Connect the [TEST PORT] of the test fixture into the down stream facing port under the test of the hub. Apply power to the hub.

- 4 Attach the SMA cables to the SMA connectors D+ and D- of TP2 on the test fixture.

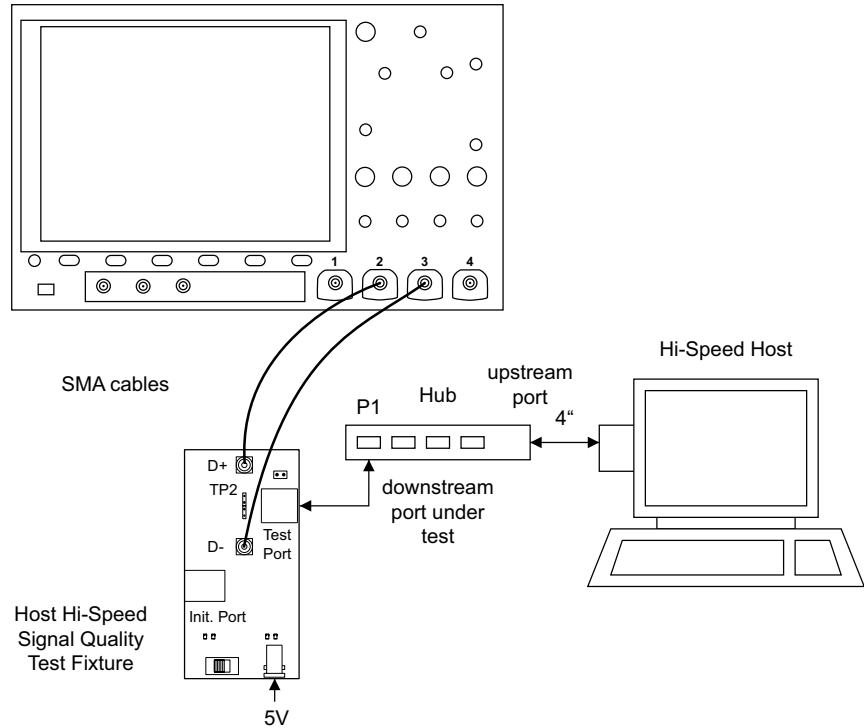

Hub Downstream Hi-Speed Compliance Test Packets

To set up the Host computer to transmit compliance test packets, perform these steps:

- 1 Invoke the HS Electrical Test Tool software on the Hi-Speed Electrical Test Bed computer. Select **Hub** and click the **TEST** button to enter the Hub Test dialog box.

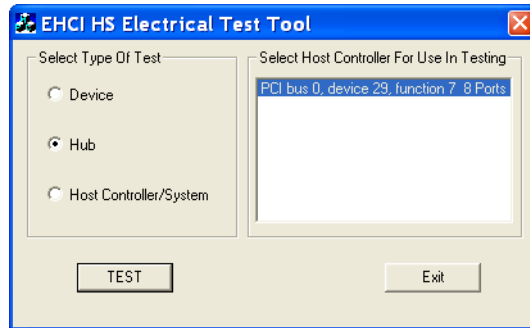

- 2 In the Hub Test dialog box, click the **Enumerate Bus** button once.

The hub under test should be enumerated with the hub's VID shown together with the USB address.

- 3 Select **TEST_PACKET** from the **Port Control** drop down menu.
- 4 Enter the port number of the hub port being tested.

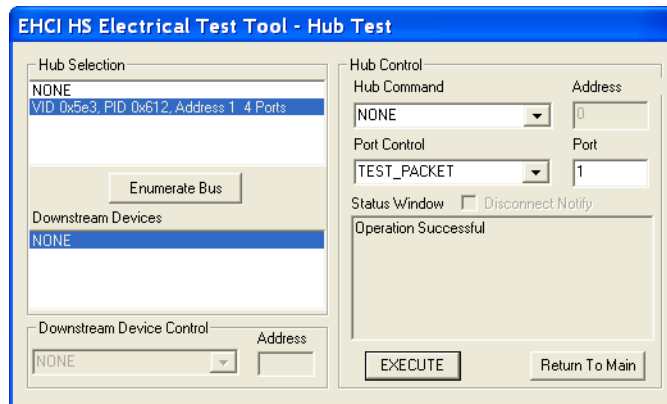

- 5 Click **EXECUTE**.

Hub Downstream Full Speed Signal Quality Test

Table 12 Equipment Used in Hub Downstream Full Speed Signal Quality Test

| Quantity | Item | Description/Model |
|----------|------------------------|--|
| 1 | Oscilloscope | Keysight 4000/6000 X-Series |
| 2 | Passive probes | Probes included with the oscilloscope are sufficient. |
| 1 | Host test bed computer | Any computer with the Windows XP, Windows 7, or Windows 8 operating system and hi-speed USB ports. |
| 1 | SQiDD board | Keysight E2646A/B |
| 1 | full speed USB device | Intel Create and Share USB camera, P/N 735147-001, Model #: CS330 |
| 5 | USB self-powered hubs | Any listed on USB-IF web site |
| 6 | 5 meter USB cables | Any listed on USB-IF web site |

To set up and run the Host Full Speed signal quality tests:

- 1 Connect the USB Device, test fixtures, and equipment. See **“Hub Downstream Full Speed Connection”** on page 79.
- 2 Set up the test signal/packet that will be analyzed.

Hubs produce downstream signals that can be tested. Connect a known good Full Speed device to the hub under test and capture the Full Speed SOF to perform the eye pattern analysis.
- 3 On the oscilloscope's front panel, press the **[Analyze]** key.
- 4 In the Analyze Menu, press the **Features** softkey; then, select **USB Signal Quality**.
- 5 Press the **Test** softkey and select the **Host Full Speed Signal Quality** test.

- 6 Press the **Settings** softkey. In the USB Signal Quality Settings Menu:
 - a Press the **D+ Source** softkey and select the analog input source channel connected to the D+ signal (channel 2 in the previous connection instructions).
 - b Press the **D- Source** softkey and select the analog input source channel connected to the D- signal (channel 3 in the previous connection instructions).

On 4-channel oscilloscopes, you are forced to use different channel pairs for the D+ and D- signals. This provides the maximum sample rate. (Channels 1 and 2 are one pair and channels 3 and 4 are the other pair.)

When full speed tests are run on a 2-channel oscilloscope, a statement about the analysis data being under-sampled will be included in the test results.

- 7 Press the **Auto Setup** softkey to automatically set up the oscilloscope for the selected test.

For optimal test results, you can make adjustments to the auto setup. Generally, you want one packet of data, plus the time of one bit on each end, across the oscilloscope's display. Also, vertical scale and offset should be adjusted so that the signals take six vertical divisions without being clipped.

You should see the transmitted test packet on the oscilloscope as below.

5 Hub Downstream Signal Quality Testing

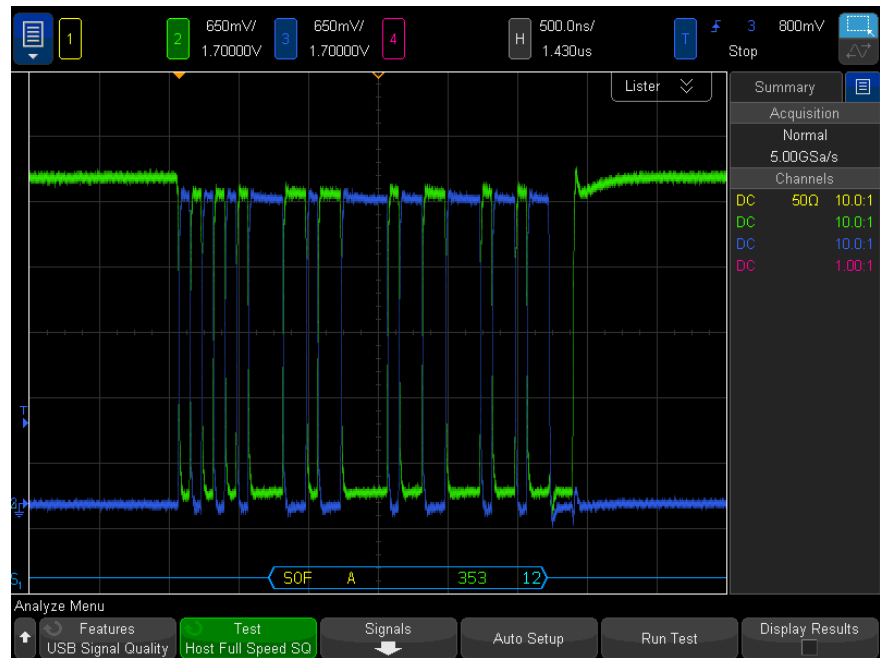

8 Press the **Run Test** softkey to run the selected signal quality test.

When tests are run, the oscilloscope stops acquisitions if they are running, analyzes the data on screen, and then displays the results.

NOTE

Tests can take several minutes to run and cannot be cancelled once started.

When the test completes, the results are automatically displayed. You can press the **Display Results** softkey to disable or reenble the test results display.

The analyzed acquisition remains on screen and can be viewed by moving or dismissing the results dialog box.

You can run tests when the oscilloscope is already stopped. This is useful in the case of embedded hosts (and other cases) where the device under test (DUT) may not easily be placed in a test mode, and you want to analyze already acquired data.

See Also · **Chapter 6**, “Saving Test Results to an HTML File,” starting on page 85

Hub Downstream Full Speed Connection

Perform these connection steps:

- 1** Attach the passive probes to the oscilloscope's Channel 3 and Channel 2 inputs.
- 2** Attach the SQiDD board to the hub under test.
- 3** Attach the upstream port of the hub under test to the end of 4 self-powered hubs and a host system. Hub #1 has to be a full-speed hub and hub #2 a Hi-speed hub. The other hubs can be either full speed or hi-speed hubs.

NOTE

Placing a full speed and/or a high-speed device downstream of a full speed hub forces both to operate in full speed mode.

-
- 4** Attach a full speed device to the same section of the SQiDD board. If the section has a switch, it should be set to ON.
 - 5** Connect the oscilloscope Channel 2 probe to D+ probe point of the device under test portion. Connect the oscilloscope channel Channel 3 probe to the D- probe point of the device under test portion.
 - 6** Exit the HS Electrical Test Tool if you have previously launched it.

5 Hub Downstream Signal Quality Testing

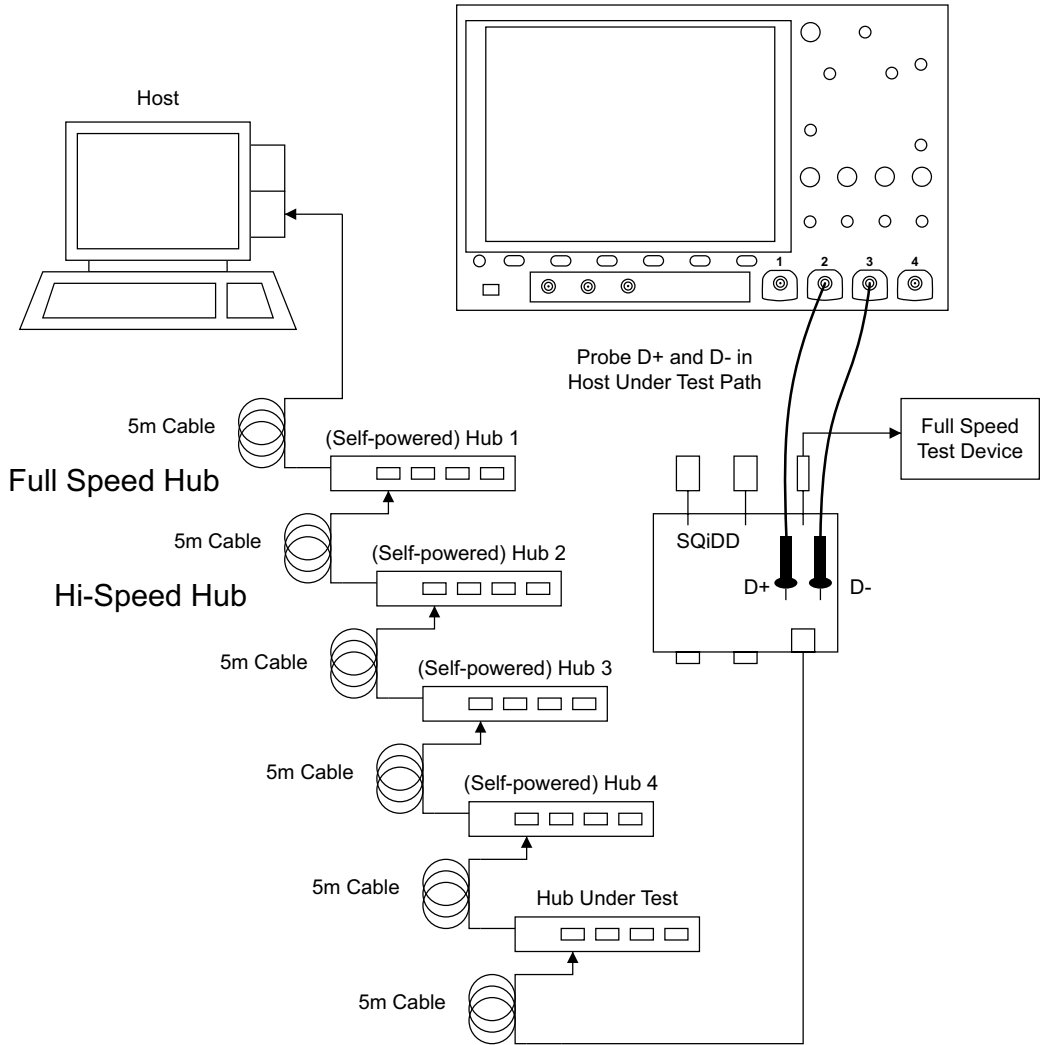

Hub Downstream Low Speed Signal Quality Test

Table 13 Equipment Used in Hub Downstream Low Speed Signal Quality Test

| Quantity | Item | Description/Model |
|----------|------------------------|--|
| 1 | Oscilloscope | Keysight 4000/6000 X-Series |
| 2 | Passive probes | Probes included with the oscilloscope are sufficient. |
| 1 | Host test bed computer | Any computer with the Windows XP, Windows 7, or Windows 8 operating system and hi-speed USB ports. |
| 1 | SQiDD board | Keysight E2646A/B |
| 1 | low speed USB device | Any USB mouse |
| 5 | USB self-powered hubs | Any listed on USB-IF web site |
| 5 | 5 meter USB cables | Any listed on USB-IF web site |

To set up and run the Hub downstream Low Speed signal quality tests:

- 1 Connect the USB Device, test fixtures, and equipment. See **"Hub Downstream Low Speed Connection"** on page 83.
- 2 Set up the test signal/packet that will be analyzed.

Hubs produce downstream signals that can be tested. Connect a known good Low Speed device to the hub under test and capture a Low Speed packet to perform the eye pattern analysis.
- 3 On the oscilloscope's front panel, press the **[Analyze]** key.
- 4 In the Analyze Menu, press the **Features** softkey; then, select **USB Signal Quality**.
- 5 Press the **Test** softkey and select the **Host Low Speed Signal Quality** test.
- 6 Press the **Settings** softkey. In the USB Signal Quality Settings Menu:
 - a Press the **D+ Source** softkey and select the analog input source channel connected to the D+ signal (channel 2 in the previous connection instructions).
 - b Press the **D- Source** softkey and select the analog input source channel connected to the D- signal (channel 3 in the previous connection instructions).

5 Hub Downstream Signal Quality Testing

On 4-channel oscilloscopes, you are forced to use different channel pairs for the D+ and D- signals. This provides the maximum sample rate. (Channels 1 and 2 are one pair and channels 3 and 4 are the other pair.)

- 7 Press the **Auto Setup** softkey to automatically set up the oscilloscope for the selected test.

For optimal test results, you can make adjustments to the auto setup. Generally, you want one packet of data, plus the time of one bit on each end, across the oscilloscope's display. Also, vertical scale and offset should be adjusted so that the signals take six vertical divisions without being clipped.

You should see the transmitted test packet on the oscilloscope as below.



- 8 Press the **Run Test** softkey to run the selected signal quality test.

When tests are run, the oscilloscope stops acquisitions if they are running, analyzes the data on screen, and then displays the results.

NOTE

Tests can take several minutes to run and cannot be cancelled once started.

When the test completes, the results are automatically displayed. You can press the **Display Results** softkey to disable or reenables the test results display.

The analyzed acquisition remains on screen and can be viewed by moving or dismissing the results dialog box.

You can run tests when the oscilloscope is already stopped. This is useful in the case of embedded hosts (and other cases) where the device under test (DUT) may not easily be placed in a test mode, and you want to analyze already acquired data.

See Also · [Chapter 6](#), “Saving Test Results to an HTML File,” starting on page 85

Hub Downstream Low Speed Connection

Perform these connection steps:

- 1 Use the passive probes included with the oscilloscope.
- 2 Attach the passive probes to the oscilloscope's Channel 3 and Channel 2 inputs.
- 3 Attach the SQiDD board to the hub under test.
- 4 Attach the upstream port of the hub under test to the end of 4 self-powered hubs and a host system. Hub #1 has to be a full speed hub. The other hubs can be either full speed or hi-speed hubs.

NOTE

The best method to capture and analyze low-speed downstream signal quality is to capture both a keep-alive (low speed EOP) if present and a SOF packet. Hubs are required to generate keep-alives when there is full speed traffic and pass them on to low speed devices.

- 5 Attach a low speed device to the same section of the SQiDD board. If the section has a switch, it should be set to ON.
- 6 Connect the oscilloscope Channel 2 probe to D+ probe point of the device under test portion. Connect the oscilloscope Channel 3 probe to the D- probe point of the device under test portion.
- 7 Exit the HS Electrical Test Tool if you have previously launched it.

5 Hub Downstream Signal Quality Testing

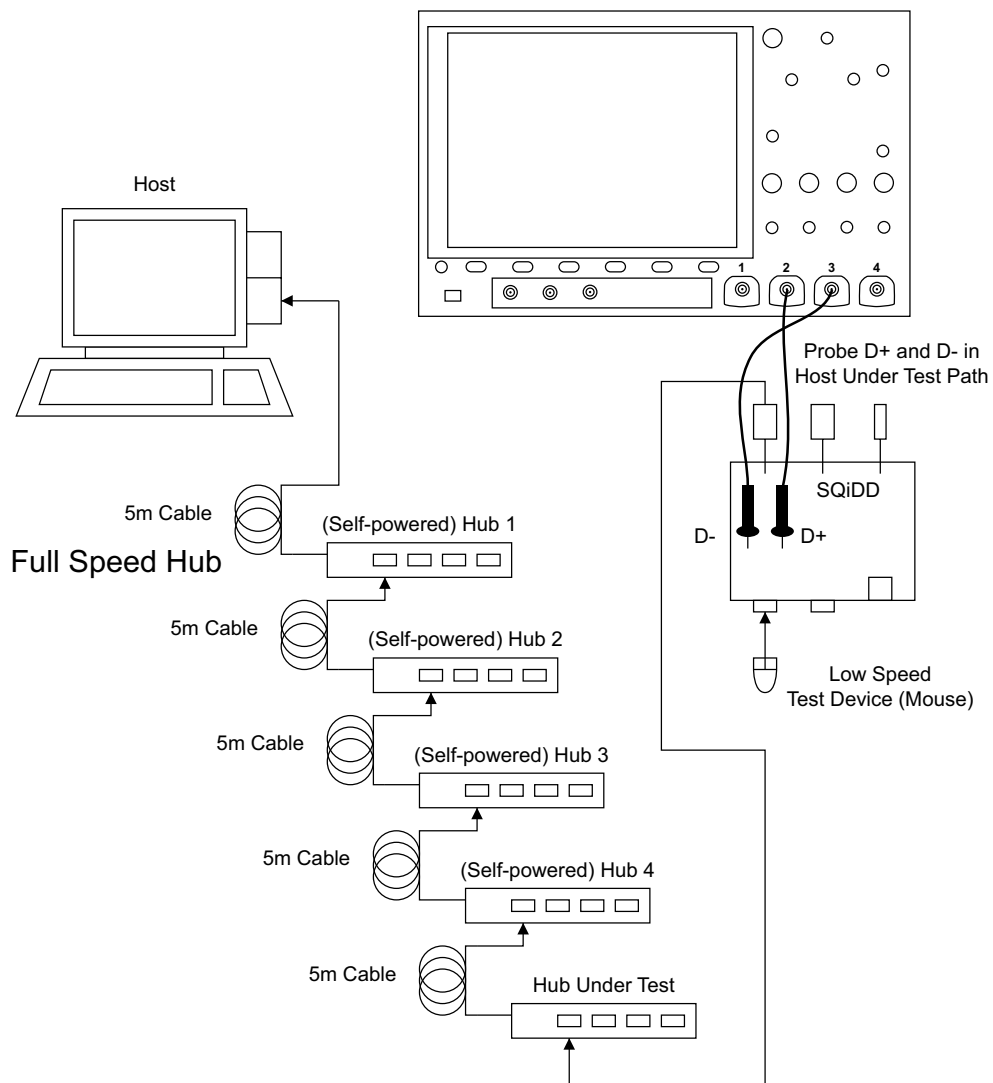

6 Saving Test Results to an HTML File

To save USB 2.0 signal quality test results:

- 1 Connect a USB storage device to one of the oscilloscope's USB Host ports.
- 2 On the oscilloscope's front panel, press **[Save/Recall]** > **Save** > **Format** and select the **USB Signal Quality** option.
- 3 Press the second softkey; then, use the File Explorer to browse to the location where you want to save the test results file.
- 4 Press the **File Name** softkey and specify the name of the test results file.
- 5 Press the **Press to Save** softkey.

NOTE

You can also e-mail test results by pressing **[Save/Recall]** > **Email** and using the softkeys in the **Email Menu**.

6 Saving Test Results to an HTML File

A Probing Hi-Speed Signals with InfiniiMode Using SQiDD as a Feedthrough

If you need a feed-through that will let you probe Hi-Speed signals with the N2750A Series InfiniiMode probe, you can use the E2646A/B SQiDD test fixture (normally used for Full and Low Speed testing) and InfiniiMode probes.

Use the center section of the board as the feed-through. Probe the signals using the test points.

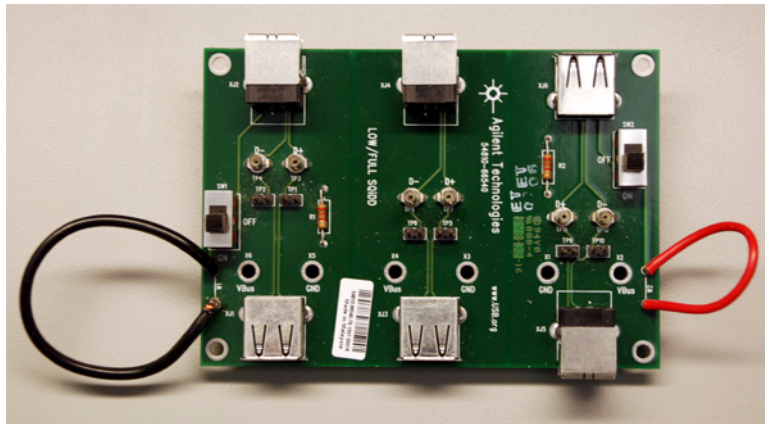

Figure 2 E2646A/B SQiDD Board

A Probing Hi-Speed Signals with InfiniiMode Using SQiDD as a Feedthrough

Index

Numerics

01131-68703 header adapter, [13](#)
4000/6000 X-Series oscilloscopes, [9](#)

A

at a glance, [3](#)

B

band width (oscilloscope)
requirements, [9](#)

C

cables, USB, [16](#)
calibrate probes, [18](#)
calibration, [18](#)
channel pairs, [20, 28, 34, 40, 46, 50, 56, 62, 70, 77, 82](#)
common ground reference, [15](#)
compensate passive probes, [18](#)
compliance test packets, device full speed, [32](#)
compliance test packets, device hi-speed, [26](#)
compliance test packets, device low speed, [37](#)
compliance test packets, host hi-speed, [44](#)
compliance test packets, hub downstream hi-speed, [74](#)
compliance test packets, hub upstream full speed, [66](#)
compliance test packets, hub upstream hi-speed, [60](#)
compliance testing, additional equipment and set up, [16](#)
computer, high-speed electrical test bed, [17](#)
connection, device full speed, [30](#)

connection, device hi-speed, differential probe, [24](#)
connection, device hi-speed, SMA cables, [25](#)
connection, device low speed, [36](#)
connection, host full speed, [48](#)
connection, host hi-speed, differential probe, [42](#)
connection, host hi-speed, SMA cables, [43](#)
connection, host low speed, [52](#)
connection, hub downstream full speed, [79](#)
connection, hub downstream hi-speed, differential probe, [72](#)
connection, hub downstream hi-speed, SMA cables, [73](#)
connection, hub downstream low speed, [83](#)
connection, hub upstream full speed, [64](#)
connection, hub upstream hi-speed, differential probe, [58](#)
connection, hub upstream hi-speed, SMA cables, [59](#)

D

decode and triggering, USB2.0, [10](#)
device full speed signal quality test, [27](#)
device hi-speed signal quality test, [19](#)
device low speed signal quality test, [33](#)
device signal quality testing, [19](#)
devices, USB, [16](#)
differential probe connection, [14](#)
DSOX4USBFL/DSOX6USBFL USB 2.0 Full/Low-Speed triggering and decode, [10](#)
DSOX4USBH/DSOX6USBH USB 2.0 Hi-Speed triggering and decode, [10](#)

DSOX4USBSQ/DSOX6USBSQ USB 2.0 Signal Quality Analysis application, [9](#)

E

E2646A/B SQiDD board, [13](#)
E2646A/B SQiDD test fixture, [87](#)
EHCI driver stack, [17](#)
electrical test bed computer, [17](#)
equipment required, [9](#)

F

far-end, [20, 40, 56, 70](#)
firmware version (oscilloscope) requirements, [9](#)
fixture, Full/Low Speed signal quality test, [13](#)
fixtures, Hi-Speed signal quality test, [10](#)

G

ground reference, common, [15](#)

H

header adapter, 01131-68703, [13](#)
high-speed electrical test bed computer, [17](#)
High-Speed Electrical Test Tool Kit software, [17](#)
host full speed signal quality test, [45](#)
host hi-speed signal quality test, [39](#)
host low speed signal quality test, [50](#)
host signal quality testing, [39](#)
hub downstream full speed signal quality test, [76](#)
hub downstream hi-speed signal quality test, [69](#)

Index

hub downstream low speed signal
quality test, [81](#)
hub downstream signal quality
testing, [69](#)
hub upstream full speed signal quality
test, [61](#)
hub upstream hi-speed signal quality
test, [55](#)
hub upstream signal quality testing, [55](#)
hubs, number of, [40](#), [70](#)

N

N2750A Series InfiniiMode probe, [87](#)
near-end, [20](#), [40](#), [56](#), [70](#)
notices, [2](#)
number of hubs, [40](#), [70](#)

O

oscilloscope requirements, [9](#)
oscilloscope, software, and
accessories, [9](#)
overview, [3](#)

P

passive probes, compensating, [18](#)
prerequisites, [9](#)
probe requirements, [13](#)
probes, calibrating, [18](#)

R

required equipment and software, [9](#)
requirements, probe, [13](#)

S

saving test results, [85](#)
SMA cable connection, [15](#)
SQiDD board, [13](#)

T

test bed computer, high-speed
electrical, [17](#)
test fixtures, USB electrical, [10](#)
test results, saving, [85](#)

trademarks, [2](#)
triggering and decode, USB2.0, [10](#)

U

USB cables used in testing, [16](#)
USB devices used in testing, [16](#)
USB electrical test fixtures, [10](#)
USBHSET software, [17](#)