

To buy, sell, rent or trade-in this product please click on the link below:  
<http://www.avionteq.com/IFR-AEROFLEX-ATC-1200Y3-Transponder-DME-Test-Set.aspx>

**AvionTEq**

Test with full trust

[www.avionteq.com](http://www.avionteq.com)

# ATC-1200Y3

## TRANSPONDER and DME TEST SET

### OPERATION and MAINTENANCE MANUAL



10200 WEST YORK STREET/WICHITA, KANSAS 67215 U.S.A. / (316) 522-4981/TWX 910-741-6952

1002-1456-900

PUBLISHED BY  
IFR SYSTEMS, INC.  
Wichita, Kansas

Copyright © 1987 by IFR SYSTEMS, INC.

All rights reserved. Printed in the United States of America. No part of this publication may be reproduced, stored in a retrieval system, or transmitted in any form or by any means, electronic, mechanical, photocopying, recording or otherwise without the prior permission of the publisher.

Manual Part Number: 1002-1456-900

ATC-1200Y3  
NOTICE

FOR 115 VAC INPUT OPERATION CONNECT POWER TRANSFORMER  
LEADS AS FOLLOWS:

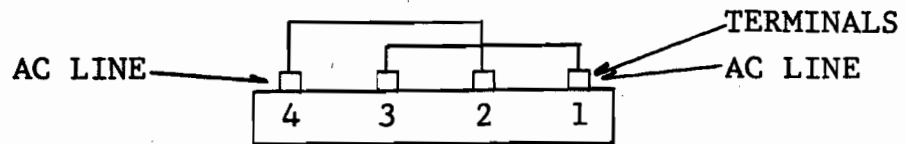

Jumper 1 to 3, 2 to 4.

FOR 230 VAC INPUT OPERATION CONNECT POWER TRANSFORMER  
LEADS AS FOLLOWS:

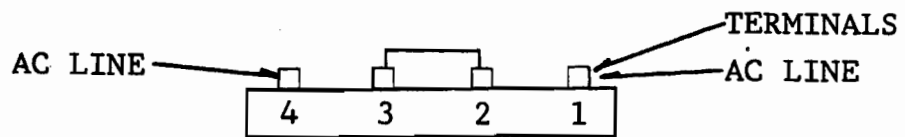

Jumper 2 to 3.

## SECTION I

### General Information

- 1-1. Description.
- 1-2. The ATC-1200Y3 is a civil transponder and DME test instrument designed to meet the functional test requirements of a pulse test station. Only a high-quality, dual-trace oscilloscope and a counter are needed in addition to the ATC-1200Y3.
- 1-3. The ATC-1200Y3 is equally at home testing the simplest DME, or the sophisticated ARINC transponder or DME of latest design. Transponder tests feature interrogation in all modes including A/C, rapid setting of transmitter frequency and measurement of transmitter power. Receiver sensitivity checks are accurate and fast using the convenient front panel display of % reply.
- 1-4. DME tests include accurate range measurements in 0.01 mile steps to 999.89 miles and equally accurate velocity measurements in 10 KT steps to 9990 KTS. Both are crystal controlled. Tests to measure transmitter frequency, transmitter power, decoder window limits and receiver sensitivity are all front panel functions.
- 1-5. The built-in L-Band signal generator covers the spectrum of 950 - 1225 MHz. It may be operated in any of three modes: a) a crystal controlled, phase-locked generator with direct frequency readout, b) a crystal controlled, phase-locked generator with paired VOR channel readout, or c) as a continuously variable frequency generator from 950 - 1225 MHz. A CW function allows the test set to be used as a general purpose L-Band generator of high stability and including an accurate output attenuator.
- 1-6. Warranty. (See following page)

## SECTION II

### Specifications

and

### Technical Summary

#### Transponder Section

Interrogation Rate: Variable from 50 Hz to 5000 Hz.  
PRF control accuracy  $\pm 5\%$ .

Interrogation Modes: A/C, A, B, C, and D, per FAA  
TSO C-74a. Pulse spacing re-  
lative to leading edge of P1:

Mode A	8us $\pm 0.05$ us
Mode B	17us $\pm 0.06$ us
Mode C	21us $\pm 0.06$ us
Mode D	25us $\pm 0.08$ us
Mode A/C	8us $\pm 0.06$ us 21us $\pm 0.08$ us

#### Transponder Pulse Characteristics:

Pulse rise times should be 100ns or less for P1, P2 and P3. When the leading edge of P2 is within 0.6us or less of the trailing edge of P1, the rise time of P2 degrades to greater than 100ns. If P2 is within 0.3us of the trailing edge of P1, and P1 and P2 will deform. P2 may vanish.

Variable Pulse Spacing: P2 and P3 variable  $\pm 1.0$ us from each nominal position. Control accuracy  $\pm 0.05$ us at 0 setting and  $\pm 0.1$ us at +1 and -1us settings.

Variable Pulse Width: Variable width (of all three pulses simultaneously) from 0.4us to 1.2us. Control accuracy  $\pm 0.05$ us.

Side Lobe Suppression: Side Lobe pulse spaced 2us relative to P1. Spacing accuracy  $\pm 0.05$ us. Variable in amplitude relative to P1 from -10dB to +1dB, control accuracy  $\pm 0.5$ dB at +1dB and 0dB; and  $\pm 1$ dB at -6 and -10dB. P2 pulse may be turned off.

Pre Pulse: Selectable On or Off by Front Panel switch. Equal in Amplitude and Width to P1 and P3. Time before P1 adjustable to 5us by the CAL  $\emptyset$  control

Calibration Mark Gen: Crystal controlled 1.0us or 1.45us time marks. Crystal tolerance  $\pm .01\%$ . 1us frequency = 1 MHz. 1.45us frequency = .689650 MHz. Output pulse amplitude adjustable to 1V P-P with 51 ohm load.

Sync Pulses:  $T_0$ : Negative sync pulses are provided approximately 5us prior to the leading edge of P1.  
 $T_D$ : Negative sync pulses are provided on the leading edge P3 for monitoring of all reply pulses.

Nominal amplitude is -15V.  
Pulse width is 0.5 to 3us.

Transmitter Frequency Check: Transmitter frequency is measured by heterodyne method through diode mixers. Frequency settable to 500 kHz at 1090 MHz.

Transmitter RF Power: Measured by calibrated slide-back power meter. Power at any point of the reply pulse may be measured. Accuracy of power control is 12% at 2.5 kW and 15% at 50 watts.

Transponder % Reply: Meter readout 0 to 100%  
Accuracy  $\pm 2\%$ .

Suppressor Pulse: Coincident with P1 of interrogation pulse train. Pulse width is 50us,  $\pm 2$ us. Amplitude nominal 19 V,  $\pm 1$  V.

Interrogation RF Pulse Risetime: Less than 100 ns. Overshoot 5% maximum.

Interrogation RF Pulse Decay Time: Less than 100ns.

RF On/Off Ratio:

80dB minimum, 85dB typical.

DME SECTION

Squitter:

Rate of pulse pairs is variable from average of 50Hz to 5000Hz. Squitter has completely random time distribution. Average rate accuracy:  $\pm 3.5\%$ .

Ident System:

Provides constant ident tone or coded IDENT signal. Tone frequency is 1350Hz,  $\pm 1\%$ . Ident equalizing pulse is spaced 100us from first pulse. Spacing accuracy:  $\pm 3\mu\text{s}$ . IDENT signal is available every 30 seconds,  $\pm 2$  sec., of characters I-F-R. Speed: approximately 7 WPM.

Sync System:

T0: Negative sync pulses are provided approximately 1us after time of input interrogation.

Td: Sync Range - Negative sync pulses are provided (approximately 5us before) with each range reply pulse to permit viewing the reply pulses.

Sync Squitter - Negative sync pulses are provided at leading edge of P1 pulse to permit viewing squitter pulses.

Nominal amplitude of all. sync pulses is -15 V. Pulse width is 2 to 15us.

Range System:

Provides crystal controlled fixed range distances from -1 mile to 999.89 N.M. in 0.01 N.M. selectable increments. Range accuracy:  $\pm 0.025$  miles,  $\pm .005\%$  of range.

Velocity System:

Crystal controlled velocity rates from 0 to 9990 KTS, in 10KT selectable increments. Velocity accuracy 0.02%. Velocity range 0 to 300 N.M. with meter readout. Range readout accuracy  $\pm 5$  N.M. Electrical slewing 0 to 300 N.M. in approximately 6 sec.

NOTE

Due to discrete range steps in Velocity mode of .01 mile and to range jitter of .01 mile max, the maximum range uncertainty is .02 mile when measuring velocity on a time interval counter. If the range-change verses time measurement is made at 1000 knots for 60 seconds, the maximum velocity error due to the .02 mile uncertainty is  $\pm 0.12\%$ . See table below.

A. When measuring at a 60 second time interval:

<u>Velocity</u>	<u>Maximum Error</u>
100	1.2%
200	0.6%
500	0.24%
1000	0.12%
5000	0.024%

B. When measuring at a 30 second time interval:

<u>Velocity</u>	<u>Maximum Error</u>
100	2.4%
200	1.2%
500	0.48%
1000	0.48%
5000	0.048%

C. When measuring at a 10 second time interval:

<u>Velocity</u>	<u>Maximum Error</u>
100	7.2%
200	3.6%
500	1.44%
1000	0.72%
5000	0.144%

Percent Reply:

Random Reply elimination with average count down rate variable from 20% to 100% replies. Control accuracy  $\pm 5\%$ .



Tacan Simulation: Simulation only by amplitude modulating all output pulses with 60Hz. Modulation level variable from 0 to 50%.

Suppressor Pulse: Output rate is a constant value controlled by Squitter PRF control. Pulse width is 50us  $\pm$ 2us. Amplitude nominal 19V  $\pm$ 1V.

R-NAV Pulses: P1 at time of interrogation; P2 at time of reply. Pulse spacing at 0 miles is 50 us in X ch,  $\pm$ 0.25 us, and 56us in Y ch,  $\pm$ 0.25us. Pulse width is 7us,  $\pm$ 3us, amplitude 15 v,  $\pm$ 3V.

Decoder: An input decoder is incorporated which will accept input pulse pairs only with spacings between:

- in X ch - 8.5us to 15.5us  $\pm$ 0.5us.
- in Y ch - 33.5us to 38.5us  $\pm$ 1.0us

DME Pulse Widths Characteristics:

DME pulse widths should be 3.5us  $\pm$ 0.25us when on a frequency of 1030 MHz. Typical pulse width variation with frequency is  $\pm$ 0.5us. For "X" channel operation the spacing cannot be operated in the -4us, -5us or -6us position without severe pulse distortion because P1 and P2 are being overlapped.

Output Pulse Spacing: In X channel 12us,  $\pm$ 0.2us. In Y channel 30us,  $\pm$ 0.2us. Pulse spacing is adjustable from nominal 12 or 30us in  $\pm$ 0.5,  $\pm$ 3,  $\pm$ 4,  $\pm$ 5 and  $\pm$ 6us steps. Accuracy of incremental spacing is  $\pm$ 0.2us. X or Y channel spacing by VOR frequency selected.

Echo Pulses:

Echo Pulse pair injected 30 N.M. from time of interrogation. Range accuracy of echo pulses  $\pm 0.5$  N.M. Echo pulse amplitude variable from -10 dB to +1dB, control accuracy  $\pm 0.5$  dB at -10 dB, -6 dB, 0 dB, and +1 dB, relative to normal reply pulse. Normal reply pulses cannot be used within  $\pm 5$  N.M. of echo pulses. Echo pulse pair may be turned off. All output pulses are square instead of Gaussian shaped when the echo system is activated.

PRF Measurement:

Interrogation rate of DME read out on meter on 0-30 and 0-300 PRF ranges. PRF accuracy  $\pm 3\%$  full scale.

Modulator Pulse Output:

Gaussian-shaped reply pulse pair timed within  $\pm 0.3\mu\text{s}$  of RF reply pulses. Amplitude adjustable from 0 V to -10.5 V. D.C. restored to peak of 0 V. Spacing same as RF pulses.

Transmitter Frequency Check:

Transmitter frequency is measured by heterodyne method through diode mixers. Used only to verify proper on-channel frequency to  $\pm 1$  MHz.

Transmitter RF Power:

Measured by calibrated slide-back power meter. Power at any point of the interrogate pulse may be measured. Accuracy of power control is 12% at 2.5 kW and 15% at 50 watts.

DME RF pulse output:

Gaussian-shaped reply pulses  $3.5\mu\text{s}$ ,  $\pm 0.25\mu\text{s}$ , wide at 50% amplitude point.

RF On/Off Ratio:

85 dB minimum, 95 dB typical.

## Signal Generator Section

Frequency:

950 MHz to 1225 MHz

Frequency Control:

1. In GHz position, the front panel frequency switch indicates generator frequency directly in MHz providing decimal point is considered invalid. Phase lock range typically 960 MHz to 1215 MHz. Frequency selected in 1 MHz increments. Output frequency accuracy  $\pm 0.008\%$ . DME spacing always X ch in GHz mode.
2. Paired VOR channel readout: Front panel frequencies switch indicates VOR frequencies from 108.00 to 117.95 MHz, and 133.30 to 135.95 MHz selectable in 50 kHz increments. Output frequency from 962 MHz to 1213 MHz paired to VOR channels. Phase lock range 962 to 1213 MHz. Output frequency accuracy  $\pm 0.008\%$ . All XXX.00 channels select X ch. spacing; all XXX.05 channels select Y ch. spacing.
3. Variable Frequency: Range 950 MHz to 1225 MHz, Drift rate typically less than 2.0 MHz in a one-hour period. An external counter capable of counting 3.25 MHz can display the output frequency. Add 9 MHz to the counter reading and multiply the sum by 100 to obtain the output frequency.

Output Leveling:

For sets S/N 1500 and on, RF output leveled to  $\pm 1.0$  dB for any one attenuator setting in 962 to 1213 MHz frequency range.  
For sets prior to S/N 1500, RF output leveled to  $\pm 2.0$  dB for any one attenuator setting over frequency range 962 to 1213 MHz.

RF Output Level:

Continuously variable from 0 dBm to -110 dBm. Attenuator accuracy  $\pm 1.5$  dB referenced to Output Leveling. Output level is calibrated at XMTR/REC connector. Harmonic content of output 70 dB down from attenuator is non-linear from 0 dBm to -30 dBm. Use of attenuator calibration curve is mandatory for this region of operation.

General

AC Power Requirements:

105 to 120 VAC or 220 to 250 VAC  
50 to 400 Hz. Cooling fan 50/60  
Hz only.

Weight:

36 pounds

Dimensions:

7.5" high, 16.75" wide,  
18.375" deep.

SECTION II  
INSPECTION

- 2-1. **INCOMING INSPECTION.** Each IFR Precision Simulator is carefully inspected for mechanical and electrical quality before shipment from the factory. On receipt, the instrument should be physically free of marks and scratches, and in perfect mechanical and electrical order. The instrument should be inspected immediately for possible in-transit physical damage. A check for supplied accessories, and a test of the electrical performance of the instrument (as outlined in Section V of this manual) should also be made. Any damage or deficiency should be reported immediately to the carrier and a claim filed, if necessary. Refer to the **LIMITED WARRANTY AND SERVICE INSTRUCTIONS** of this manual for delineation of responsibilities and liabilities. Follow the directions in the **LIMITED WARRANTY AND SERVICE INSTRUCTIONS** when it becomes necessary to ship the instrument.
- 2-2. **GROUNDING REQUIREMENTS.** To protect operating personnel, the National Electrical Manufacturer's Association (NEMA) recommends that the instrument panel and cabinet be grounded. All IFR instruments are equipped with a three-conductor power cord which, when plugged into an appropriate receptacle, grounds the instrument. The offset pin on the power cord three-prong connector is the ground wire.
- 2-2-1. To preserve this protection feature when operating the instrument from a two-contact outlet, use a three-prong to two-prong adapter and connect the green pigtail on the adapter to ground.
- 2-3. **CLEANING.** It is wise to clean the dust, cobwebs, and other debris out of the test set prior to periodic inspection, repair or calibration. Some shops clean their test equipment on a regular basis such as biannual or annual proof-of-performance checks. Annual recalibration of the set is advisable.
- 2-3-1. Dust removal is best done with a hand controlled dry air jet of 25 to 50 psi (1.827 kg/cm<sup>2</sup> to 3.653 kg/cm<sup>2</sup>). The Rear Panel should be cleaned with a dry cloth only. The Front Panel may be cleaned whenever necessary with a lint-free cloth moistened with rubbing alcohol.
- 2-3-2. **CARE MUST BE TAKEN TO AVOID BREAKING WIRES OR SHORTING COMPONENT LEADS TOGETHER DURING CLEANING.**

2-7. Repackaging for Shipment.

2-8. The following is a general guide for repackaging for shipment. If you have any questions, contact the IFR Shipping Department. (See Section I, Paragraph K )

————— NOTE —————

If the instrument is to be shipped to IFR for service or repair, attach a tag to the instrument identifying the owner and indicating the service or repair to be accomplished; include the model number and full serial number of the instrument. In any correspondence identify the instrument by prefix, model and serial number.

Place instrument in original container if available. If original container is not available, contact IFR for shipping instructions.

Do not return the instrument or its component parts to IFR, Inc. for repair without first receiving authorization from IFR, Inc. Refer to paragraph 1-H for complete instructions.

- I. Transformer. Inspect the transformer for signs of excessive heating, broken or charred insulation, and loose mounting hardware.
- J. Wiring. Inspect all the wiring of the chassis for broken or loose ends and connections and for proper dress relative to other chassis parts. All the laced wiring should be tight with the ends securely tied.

2-5. REPACKING FOR SHIPPING. The LIMITED WARRANTY AND SERVICE INSTRUCTIONS contain detailed directions for repacking and shipping. Additional questions may be directed to the IFR Shipping Department.

NOTE

Any instrument shipped to IFR for any reason MUST be tagged with (1) its owner's identification, (2) the service or repair required, (3) its model number, and (4) its full serial number. Identify the instrument by prefix, model, and serial number in ALL correspondence.

- 2-5-1. IFR Precision Simulators should be shipped ONLY in their original containers. If the original container is not available, contact IFR for shipping instructions.
- 2-5-2. DO NOT return an instrument or its component parts to IFR without first receiving authorization from the IFR Customer Service Department. Refer to the LIMITED WARRANTY AND SERVICE INSTRUCTIONS for complete directions.

- A. Chassis. Includes anything mechanical or made from metal. Inspect for tightness of sub-assemblies, damaged connectors, corrosion or damage to the metal surfaces, etc. Surface corrosion may indicate damage inside the affected part.
- B. Capacitors. Inspect for loose mounting, body damage, case damage, leakage or corrosion around leads.
- C. Jacks. Inspect all coax jacks for loose or broken parts cracked insulation, bad contacts, etc. Do not disassemble connectors within the test set.
- D. Potentiometers. Any potentiometer that feels rough when rotated or produces circuit or voltage irregularities should be checked with an ohmmeter for proper operation.
- E. Resistors. Inspect all types of resistors for cracked, broken or charred or blistered bodies and loose or corroded soldering connections.
- F. Printed Circuit Boards. Check connectors for corrosion and damage and the mating plugs for similar damage. Inspect all mounted components for damage including crystals and IC's. The board should be free of all foreign material.
- G. Semiconductors. Inspect all diodes, rectifiers and transistors for cracked, broken, charred or discolored bodies. Check ends of components for seals around leads.
- H. Switches. Examine all toggle switches for loose levers and terminals, loose body to frame condition. The line switch contacts should not be bent nor the switch action too loose. The thumbwheel switches should have definite detents and not feel loose.
- I. Transformer. Inspect the transformer for signs of excessive heating, broken or charred insulation, loose mounting hardware and other abnormal conditions.
- J. Wiring. Inspect all wiring of chassis for broken or loose ends and connections and proper dress relative to other chassis parts. All laced wiring should be tight and ends securely tied.





## 1200Y3 CONTROLS & CONNECTORS & INDICATORS

### Front Panel

1.	Interr./Squitter Rate Control	3-6
2.	P2 Dev us Control	3-7
3.	P3 Dev us Control	3-8
4.	Xpdr Pulse Width us Control	3-9
5.	Mode Switch	3-10
6.	SLS/Echo Level - dB Control	3-11
7.	Power KW Control	3-12
8.	DME Pulse P2 Dev us Control	3-13
9.	X1/X10 Prf Switch	3-14
10.	Velocity - KTS Switch	3-15
11.	Frequency Switch	3-16
12.	Distance Switch	3-17
13.	Output - dBm Control	3-18
14.	Slew In/Out Switch	3-19
15.	Dist. In/Out Switch	3-20
16.	Squitter On/Off Switch	3-21
17.	Ident Off/1350 cycle/Ident on	3-22
18.	PRF Switch 0-30/0-300	3-23
19.	Sync Select Switch TO/TD	3-24
20.	Cal us Switch 1.0/1.45 us	3-25
21.	Cal $\emptyset$ Control	3-26
22.	DME % Reply Control	3-27
23.	VAR or FREQ Switch	3-28
24.	Var Freq Sweep Controls Coarse/Fine	3-29
25.	-1 mile Switch	3-30
26.	CW Switch	3-31
27.	Range/Velocity Switch	3-32
28.	Line Switch	3-33
29.	Test Input Connector	3-34
30.	Negative Sync. Output Connector	3-35
31.	Cal us Output Connector	3-36
32.	Modulation Output Connector	3-37
33.	Counter Output Connector	3-38
34.	Generator Monitor Connector	3-39
35.	Power Monitor Connector	3-40
36.	XMTR/REC Connector	3-41
37.	Signal Generator Phase Lock Indicator	3-42
38.	Echo On Indicator	3-43
39.	Ident/Self Interr. Indicator	3-44
40.	Meter	3-45
41.	Pre-Pulse On-Off Switch	3-46

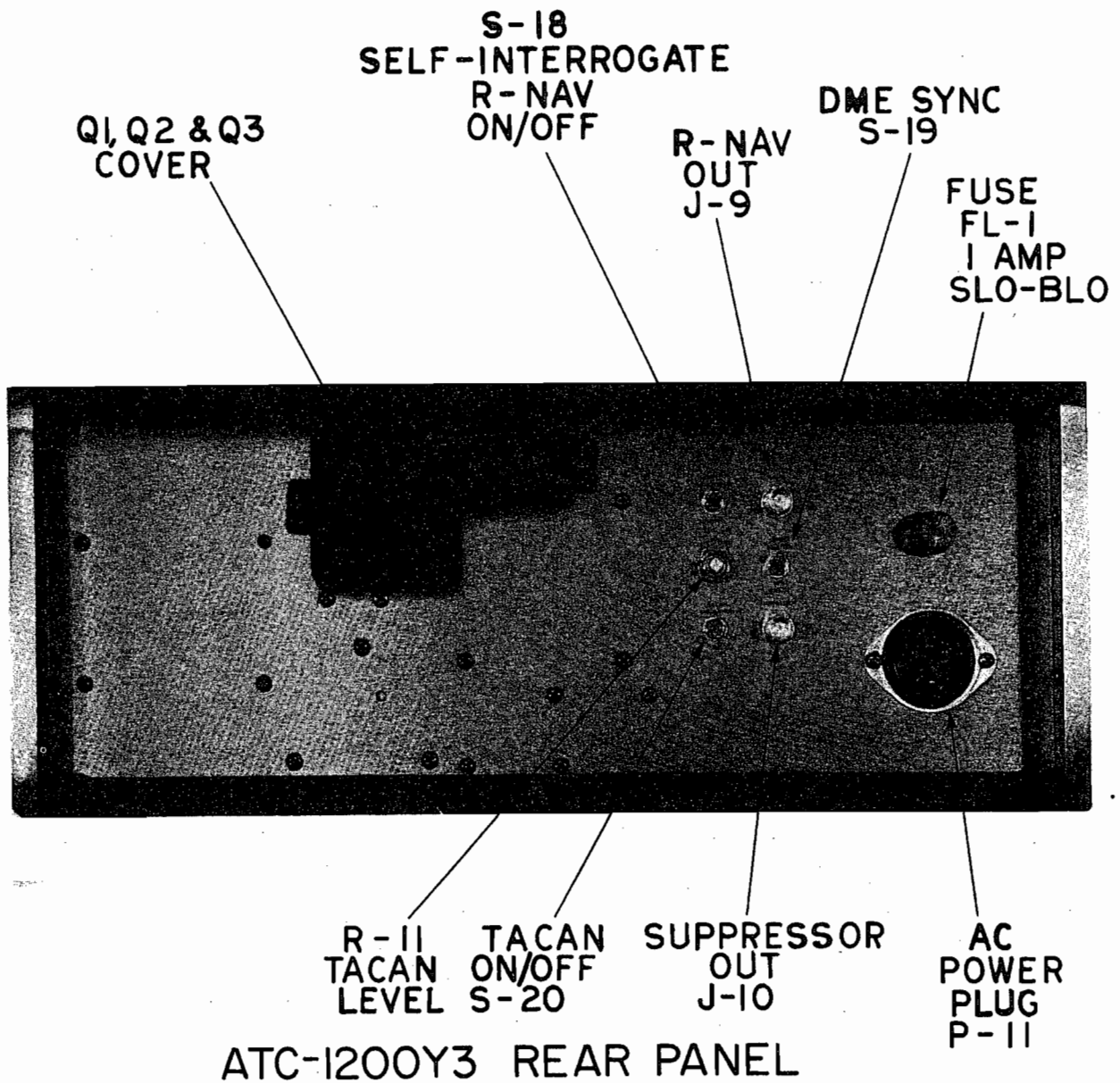

Fig 3-2

## SECTION III

### Operation

#### 3-1. INTRODUCTION

3-2. The ATC-1200Y3 is a self-contained, complete pulse test instrument for transponder and DME systems. All necessary test signals and their variations are generated with the one set. Only an oscilloscope and counter are required as peripheral equipment.

#### 3-3. CONTROLS, CONNECTORS, AND INDICATORS

3-4. Location of all controls, connectors, and indicators is shown in Figure 3-1 and Figure 3-2. The following paragraphs explain their functions in detail.

#### 3-5. FRONT PANEL

3-6. Interr./Squitter Rate Control. Known also as the PRF Control, it varies the frequency of a temperature-stabilized oscillator from 50 to 500 Hz, and 500 to 5000 Hz. The range is selected by the X1/X10 switch directly below the control. See paragraph 3-14. The oscillator is used for three purposes: a) To determine the interrogation rate of a transponder in Transponder Modes of operation, b) to determine the average squitter rate in DME Modes of operation, and c) to determine the interrogation rate of the ATC-1200Y3 itself in R-NAV operation, to permit using the test set as a DME in testing of R-NAV computers. Also when in DME Mode, the control directly determines the rate of suppressor output pulses. See paragraph 3-51, Suppressor Output Connector.

3-7. P2 DEV. us Control. The spacing of P2 (SLS pulse) relative to P1 is controlled by the smaller, outer knob of concentric controls. Actual P2 deviation is read relative to the large, inner knob with that knob set to 0.0us deviation. At 0.0 indicated, spacing is 2us, and is variable  $\pm 1.2us$ .

3-8. P3 DEV us Control. The spacing in us of P3 relative to P1 is controlled by the large, inner knob of concentric controls. When at 0.0 indicated, P3 spacing is the nominal time in us commanded by the mode of interrogation - A, B, etc. P3 spacing may be varied by  $\pm 1.2us$  from any mode spacing.

- 3-9. XPDR Pulse Width us Control. This control determines the pulse width of P1, P2, and P3 simultaneously. Nominal width is 0.8us, and may be varied from 0.4 to 1.2us.
- 3-10. Mode Switch. The Mode switch controls whether the ATC-1200Y3 operation is for Transponder or DME testing. Transponder modes are A/C, A, B, C, D, and FREQ. CHECK. Interrogation mode is A in frequency check. DME modes are DME and DME FREQ. CHECK. In frequency check position the internal signal generator is allowed to heterodyne with the incoming DME transmitter signal to determine the transmitter frequency.
- 3-11. SLS/ECHO Level - dB Control. In Transponder modes this control varies the R.F. level of the SLS Pulse, P2, relative to P1 and P3. Control range is +1 to -10 dB. At 0 the P2 level is the same as P1, which is determined by the Output - dBm control. See paragraph 3-18. In the OFF position P2 is completely turned off. In DME mode the control turns on or off a pulse pair with the same spacing as the normal reply pulse pair (12 or 30 us) and at a fixed range of 30 miles relative to time of interrogation. In addition the control varies the R.F. level of the echo pulse pair relative to the normal pulse pair from +1 to -10 dB. At 0 the echo pulses are the same amplitude as the normal reply pulses, which is determined by the Output - dBm control.
- 3-12. Power KW Control. This control varies the power meter slide-back voltage and is used in measuring both transponder and DME transmitter power levels, either peak or at any other point on the output waveform. The output power is read directly from the control scale when the point on the waveform to be measured is reduced to the base line of an oscilloscope display.
- 3-13. DME Pulse P2 DEV us Control. The DME reply pulse pairs nominally have a spacing of 12 or 30 us. The P2 DEV us control enables the test set operator to vary this spacing to less than nominal (-DEV) or greater than nominal (+DEV). Discrete steps are provided of ±0.5, ±3, ±4, ±5, and ±6us. P1 is the ranging pulse and always remains in nominal position, with P2 changing its position relative to P1.

- 3-14. X1/X10 PRF Switch. The PRF X1/X10 switch changes the dial reading of the Interr./Squitter Rate control by 10 and the frequency of the PRF oscillator by 10. See paragraph 3-6.
- 3-15. VELOCITY-KTS Switch. This switch determines the velocity rate the test set is simulating when in velocity mode. Velocity rates are in 10KT increments from 0 to 9990 KTS. Velocity range and inbound or outbound directions are determined by other controls. See paragraph 3-19 and 3-20. Velocity mode is selected by the Range/Velocity switch, paragraph 3-32.
- 3-16. Frequency Switch. The Frequency switch controls the signal generator frequency in phase-locked operation, and also determines generator frequency readout mode and DME X or Y channel reply spacing. The four left digits always select frequency. The right digit selects the mode. When in 0 position, the switch readout will be VOR paired frequencies from 108.00 thru 117.90 and 133.00 to 135.90 MHz, and the test set will be in X ch. DME reply spacing (12 us). When in 5 position, the readout is also in VOR paired frequencies only from 108.05 to 117.95 and 133.05 to 135.95 MHz (50 KHz spacing channels), and the test set will be in Y ch. DME reply spacing (30 us). When in Gz position, the readout decimal point must be moved mentally two places to the left, and the resultant display will be the output frequency in Gz. In this mode, the generator covers from .960 to 1.215 Gz. The Gz position is normally used for transponder modes but if used in DME mode (for frequency check for other purposes), the DME reply spacing is always X ch. (12 us).
- 3-17. Distance Switch. The precise range delay from interrogation to reply is selected by the Distance switches. Range distances are selected in 0.01 mile steps from 0 to 999.89 N.M. The switch is used only in fixed Range mode selected by the Range/Velocity switch, paragraph 3-32.
- 3-18. Output/dBm Control. This is the output R.F. level attenuator for the internal signal generator. The level is calibrated in -dBm normally used in transponder and DME work, and the calibration is accurate only from -30 dBm to -110 dBm. An attenuator correction curve is provided for each serial number test set for the non-linear region from -30 dBm to 0 dBm, or the low attenuation stop.

- 3-19. Slew In/Out Switch. The Slew switch rapidly moves the DME reply pulses to any range from 0 to 300 N.M., slewing inbound or outbound, when operating in velocity mode. As soon as the switch is released, the velocity switch takes over moving the reply pulses at the programmed velocity setting. Slewing from 0 to 300 miles takes approximately 6 seconds.
- 3-20. Dist. In/Out Switch. When in velocity operating mode, the Dist. In/Out switch controls whether the reply pulses will move toward 0 N.M.-inbound, or toward 300 N.M.-outbound. The rate will be determined by the velocity switch. It should be noted that when operating near either limit, when the range actually reaches the limit it will at once jump to the opposite limit and continue its original course in or out.
- 3-21. Squitter On/Off Switch. This switch turns the squitter pulses on or off. The average squitter rate is determined by the Interr./Squitter Rate control. See paragraph 3-6.
- 3-22. Ident Off/1350 cycle/Ident On Switch. The three position Ident switch a) turns off all ident signals or tones - far left position, b) turns on a steady 1350 cycle tone - center position, and c) turns on an Ident signal in code at approximately 7WPM of the characters IFR - far right position. The signal is repeated every 30 sec. Since when ident is on either continuously or in code it overrides and eliminates all reply and squitter pulses, a warning indicator is lighted continuously in center switch position and in coded form every 30 seconds in right switch position. See paragraph 3-44.
- 3-23. PRF Switch 0-30/0-300. The PRF range switch controls the meter full-scale sensitivity when reading DME interrogation PRF rates. The 0-300 N.M. meter scale and its calibrations are used. The 0-30 PRF range is normally used for DME track PRF's; the 0-300 PRF range is used for DME search PRF's. Input to the PRF measurement system is internal and requires no external, additional connections.
- 3-24. Sync Selector Switch. The Sync switch selects the source of sync signal to be presented to the neg. sync. output connector (paragraph 3-35) to permit viewing various signals concerning test operations. See the Technical Specifications for TO and TD positions in both transponder (page 2-2) and DME (page 2-3) modes. Note also that in DME mode, TD position, a rear panel switch determines actual output sync. See paragraph 3-48.

- 3-25. Cal 1.0/1.45us Switch. This selects the calibrate pulse output signal between 1.0us and 1.45us intervals. Both pulse trains are used only in transponder mode, or during DME calibration procedures of the ATC-1200Y3 itself. The 1.0us is used to monitor spacing of Xpdr interrogation pulses and the 1.45us is used to monitor spacing of reply pulses. See also paragraph 3-26 and 3-36.
- 3-26. Cal Phase ( $\emptyset$ ) Control. This control varies the phase between the interrogate and CAL pulses, or the reply and CAL pulses. Total phase variance is approximately 3.5us. The control is used to accurately align the CAL pulses with the leading edge of the interrogation or reply pulses. (See also paragraph 3-46).
- 3-27. DME % Reply Control. The % Reply Control controls the percent of return of reply pulses of the ATC-1200Y3 to an interrogating DME. The % reply can be varied from 20 to 100 percent. The reply pulse drop-out is at a completely random rate determined by an internal noise generator, and so simulates actual ground-to-air propagation path conditions.
- 3-28. VAR or FREQ Switch. The VAR or FREQ switch determines the signal generator mode of operation between a) phase-locked-frequency controlled by the Frequency Switch in FREQ position, see paragraph 3-16, or b) continuously variable frequency operation controlled by the variable frequency sweep controls in VAR position, see paragraph 3-29. In VAR position the generator frequency must be monitored by an external counter.
- 3-29. Variable Frequency Sweep Controls. Two controls are used to vary the signal generator frequency when in VAR mode. (Paragraph 3-28) A coarse control - the large, outer knob - will sweep the output frequency from 950 to 1225 MHz. The fine adjust control - the small, outer knob - will sweep the frequency approximately 1.5 to 2.5 MHz over its full range.
- 3-30. -1 Mile Switch. When turned on the -1 mile switch will subtract an exact one mile from whatever range the test set is replying at, whether in range or velocity mode. If the range switches are at 0 miles the output range will be -1 mile, enabling the operator to test steps on drum DME readouts, etc.



- 3-31. CW Switch. The CW switch disables both the ON-Off and Shaping modulators and applies CW R.F. energy to the XMTR/REC jack at the level set by the Output -dBm control. Frequency of output may be determined any one of three ways: a) phase-locked direct frequency readout, b) phase-locked VOR paired channel readout, or c) variable frequency control over the band from 950 to 1225 MHz. See paragraph 3-16 and paragraph 3-28 and 3-29.
- 3-32. Range/Velocity Switch. This switch selects between the two modes of DME Test operation of the ATC-1200Y3. Range mode gives a stationary, accurate range selected by the Distance switch. Velocity mode gives a range changing at a precision rate selected by the Velocity -KTS switch. See also paragraph 3-15 and paragraph 3-17.
- 3-33. Line Switch. Applies AC power to test set.
- 3-34. Test Input Connector. The Test Input is the input to the decoder, and is designed to be used as a twin-pulse generator test and alignment input. If the test generator is synced with the ATC-1200Y3 via an internal test point, the lus CAL pulse train will be stationary with respect to the interrogate and reply pulses and enable test set alignment to be easily accomplished.
- 3-35. Negative Sync Output Connector. The Negative Sync Pulse generated by the test set is presented at this connector to keep an oscilloscope in time with the various input and output signals. See also paragraph 3-24 and the Technical Summary under transponder and DME sync outputs.
- 3-36. CAL us Output Connector. The 1.0us or 1.45us pulse trains are presented at this connector for timing measurement of various signals. The connecting coax should be terminated in 50 ohm at the oscilloscope end.
- 3-37. Modulation Output Connector. DME shaped pulses closely coincident with the R.F. reply pulses are presented for use in modulating an I.F. generator or applying directly to a DME's ranging circuits. They are positive in amplitude (0 to 10.5 V P-P) and D.C. restored at the top of the pulses to zero volts. See Technical Summary.
- 3-38. Counter Output Connector. The output pulses direct from the counter block are presented here for determining the signal generator frequency in variable frequency mode

and to be observed on an oscilloscope periodically for pulse stability in the counter chain. To determine the output R.F. frequency, add 9 MHz to the counter reading and multiply the sum by 100.

- 3-39. Generator Monitor Connector. The R.F. pulses generated by the ATC-1200Y3 are detected, amplified and presented at this monitor connector to enable viewing the interrogation to a transponder or reply and squitter to a DME. Generally the output R.F. level should be relatively great to view these pulses. The connecting coax should be terminated in 50 ohm at the oscilloscope end.
- 3-40. Power Monitor Connector. This connector will present all pulses coming into the ATC-1200Y3. All power and frequency measurements are performed by observing these pulses. The connecting coax should be terminated in 50 ohm at the oscilloscope end.
- 3-41. XMTR/REC Connector. All RF pulses coming into or going out of the test set pass through this connector. The output -dBm control is calibrated at this connector into a 50 ohm load.
- 3-42. Signal Generator Phase Lock Indicator. Whenever the signal generator is placed in phase-lock mode and the frequency switch is set between the limits the generator will phase lock in, this indicator must be lighted. It indicates the generator is in control of the phase lock circuitry. When in variable mode, if the generator frequency is manually set at the same frequency the frequency switch is set at, the indicator may flash on and off. This is normal operation.
- 3-43. Echo On Indicator. The Echo On Indicator warns the operator he has an echo pulse pair present in the output to a DME under test which could enable him to wrongly adjust the ranging circuits. See paragraph 3-11. When echo is on, all output pulses are square instead of Gaussian shaped. This will cause the normal range to decrease by approximately 0.1 mile.
- 3-44. Ident/Self Interrogate Indicator. This indicator warns the operator that either the Ident tone has been left "on" (which will override all range pulses) or the R-NAV On/Off switch is on thus generating many false replies. The indicator will flash the code characters I-F-R when the ident switch is in the "Ident On" position.

- 3-45. Meter. The 0 to 300 N.M. scale is used for range readout when in velocity mode. It is also used as 0 to 30 or 0 to 300 PRF ranges when in range mode. The blue area of the left one - third scale is used to read transponder percent return from 0 to 100 percent. Percent return is automatically computed within the test set with a transponder operating into it. See also paragraph 3-18.
- 3-46. Pre-Pulse On-Off Switch. This toggle switch is used to enable the circuitry which generates the Pre-Pulse. This pulse is similar in amplitude and width to the normal interrogation pulses, P1 and P3. Its relationship in time preceding P1 may be altered by the CAL Ø us control. (See 3-26)
- 3-47. R-NAV On/Off Switch. This switch interrogates the ATC-1200Y3 at the rate set by the Interr/Squitter Rate Control (self-interrogate function). This feature enables the test set to operate an R-NAV computer without having a DME operating into it.
- 3-48. Sync Squitter/Sync Range Switch. When in DME mode, TD sync, this switch selects the output sync between squitter pulses or range reply pulses. The switch is inoperative in TO sync.
- 3-49. Tacan On/Off Switch. Turns on or off a 60 Hz signal used to amplitude modulate all output DME pulses to simulate TACAN modulation. See paragraph 3-52.
- 3-50. R-NAV Output Connector. R-NAV computers requiring two pulses for range information may be operated by the ATC-1200Y3 through this connector. One pulse is at time of interrogation, the other at time of reply. See also paragraph 3-47.
- 3-51. Suppressor Output Connector. Suppressor output pulses for both transponder and DME are presented here. Transponder pulses are coincident with each interrogation pulse, and DME pulses are at a steady rate set into the Interr/Squitter Rate control.
- 3-52. Tacan Level Control. When Tacan modulation is turned on (simulation only), the Level Control varies the percent of modulation from 0 to more than 50 percent. This must be adjusted by observing the video pulses in a DME with a linear video output.

- 3-53. Fuse. This fuse is in the transformer primary winding. Its normal value is 1 Amp.
- 3-54. AC Power Connector. Applies AC power to the test set. Requires a grounding-type cable and plug.
- 3-55. Internal Controls.
- 3-56. There are no internal controls useful during operation. Only calibration and alignment adjustments are internal and require very careful attention when being set. See the maintenance section of this manual for details.

## SECTION IV

### ATC-1200Y3 Operation Procedures

#### 4-1. INTRODUCTION

- 4-2. The ATC-1200Y3 was designed throughout for maximum operator's convenience and speed, while simultaneously giving him maximum accuracy of test measurements. The only equipment required external of the test set is a high-quality oscilloscope and a counter capable of 3.5 MHz. Connections to these pieces of test equipment are simple and require minimum changing during different testing operations. All R.F. signals and proper modulation signals are developed within the ATC-1200Y3 and are instantly selectable and/or variable to meet the test conditions at hand for transponder and DME work.
- 4-3. The following procedures provide information necessary to operate the ATC-1200Y3 in Transponder and DME modes. The set-ups are given to familiarize the operator with the test set versatility and typical measurement procedures. Refer to Section Three for detailed control functions.

#### 4-4. TRANSPONDER OPERATION

- 4-5. Equipment Set-up. The ATC-1200Y3 is connected to the oscilloscope and the transponder under test as shown in Figure 4-1. All connecting cables are RG-58 50 ohm coax except the R.F. cable which is recommended to be RG-8 foam coax of shortest practical length.
- 4-6. To obtain accurate pulse wave shape determination the cables used for the monitor and CAL pulse outputs should be terminated in 50 ohms at the oscilloscope end. Commonly used is a BNC Tee connector with a 51 ohm resistor in the open end of the Tee, or solder a 51 ohm resistor inside a UG-88 BNC male connector to plug on the Tee.
- 4-7. Some operators have found they can, in some operations, leave the CAL pulse cable unterminated. This produces sharp overshoots on the pulse leading edges and gives a very definite point to time from. It does in no way degrade the accuracy of the signal.

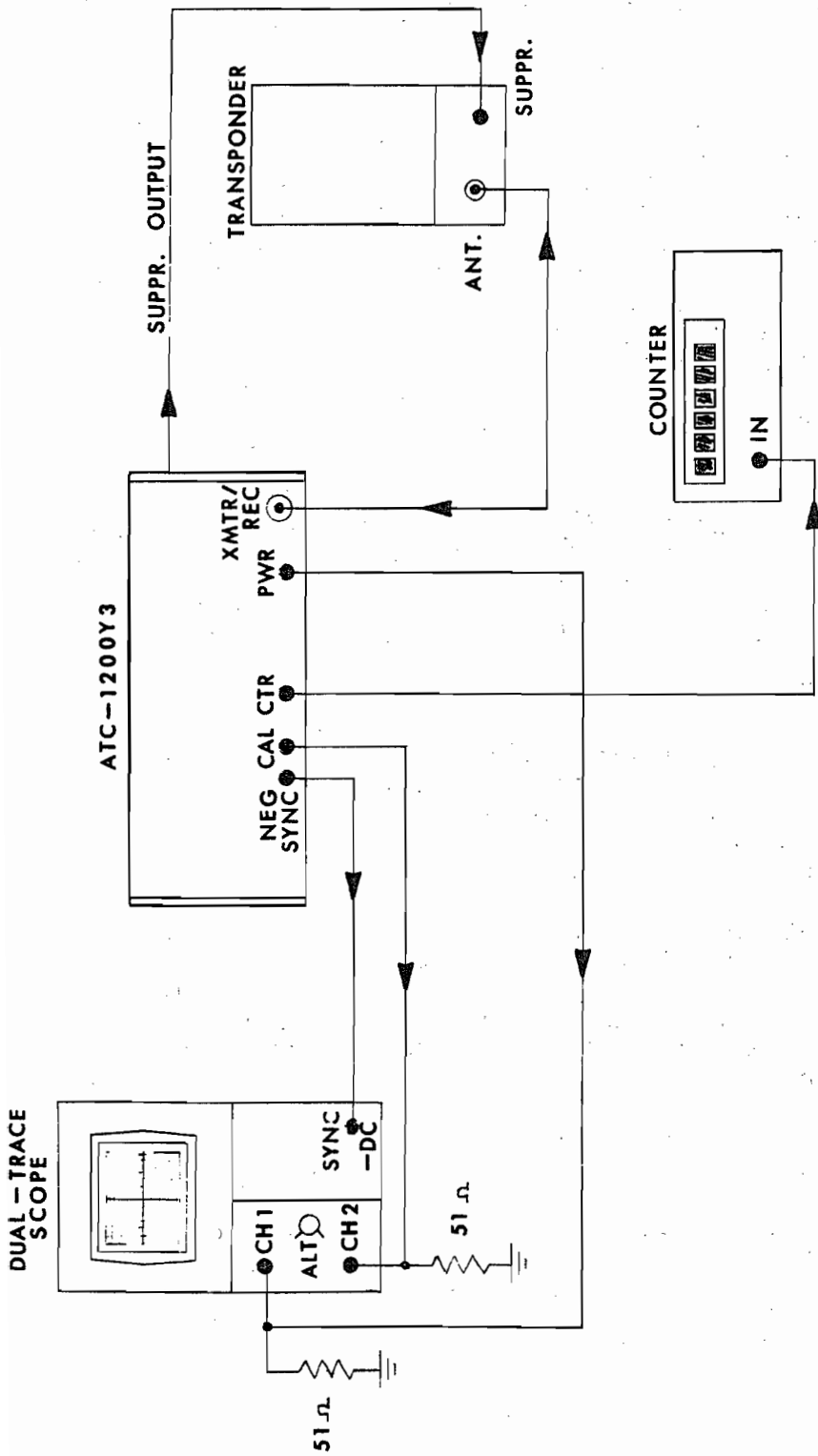

Figure 4-1  
Equipment Interconnections  
for Transponder Testing

4-8. ATC-1200Y3 Initial Control Settings

- a. MODE SWITCH to A
- b. FREQUENCY SWITCH to 1030 Gz
- c. OUTPUT - dBm control to -50 dBm
- d. INTERR/SQUITTER RATE control to 50
- e. X1/X10 SWITCH to X10
- f. Both P2 and P3 DEV us controls to 0.0
- g. XPDR PULSE WIDTH us control to 0.8us
- h. SLS/ECHO LEVEL -dB control to OFF
- i. POWER KW control full CCW
- j. TO/TD switch to TD
- k. CAL us switch to 1.45us
- l. VAR or FREQ switch to FREQ
- m. CW switch OFF
- n. LINE switch ON (red pilot lamps on)
- o. Connect cables as shown in Figure 4-1

4-9. Refer to Figure 4-2 and the following control settings for various transponder tests. Each of the tests outlined in paragraph 4-12 is a typical test only and is therefore generalized. Always refer to the calibration and alignment manual for the Transponder being tested for the specific values, settings and tests to be performed.

4-10. Oscilloscope Control Settings

- a. Both vertical gain controls to .05 V/cm
- b. Horiz. sweep to 2 us/cm
- c. Trigger input to EXT, NEG, DC
- d. Intensity as desired for 500 PRF interrogation rate
- e. VERT MODE to alternate.

4-11. Transponder Control Settings

- a. MODE SWITCH to A or A/C
- b. FUNCTION switch to ON (may be same as mode switch)
- c. CODE to 0000

4-12. TYPICAL TRANSPONDER TESTS

4-13. With the controls of the ATC-1200Y3, oscilloscope, and transponder set according to paragraphs 4-8, 4-9, and 4-10, an oscilloscope display should be observed of the transponder reply pulses. Varying the POWER KW control will change the amplitude of the reply pulses, and vary-

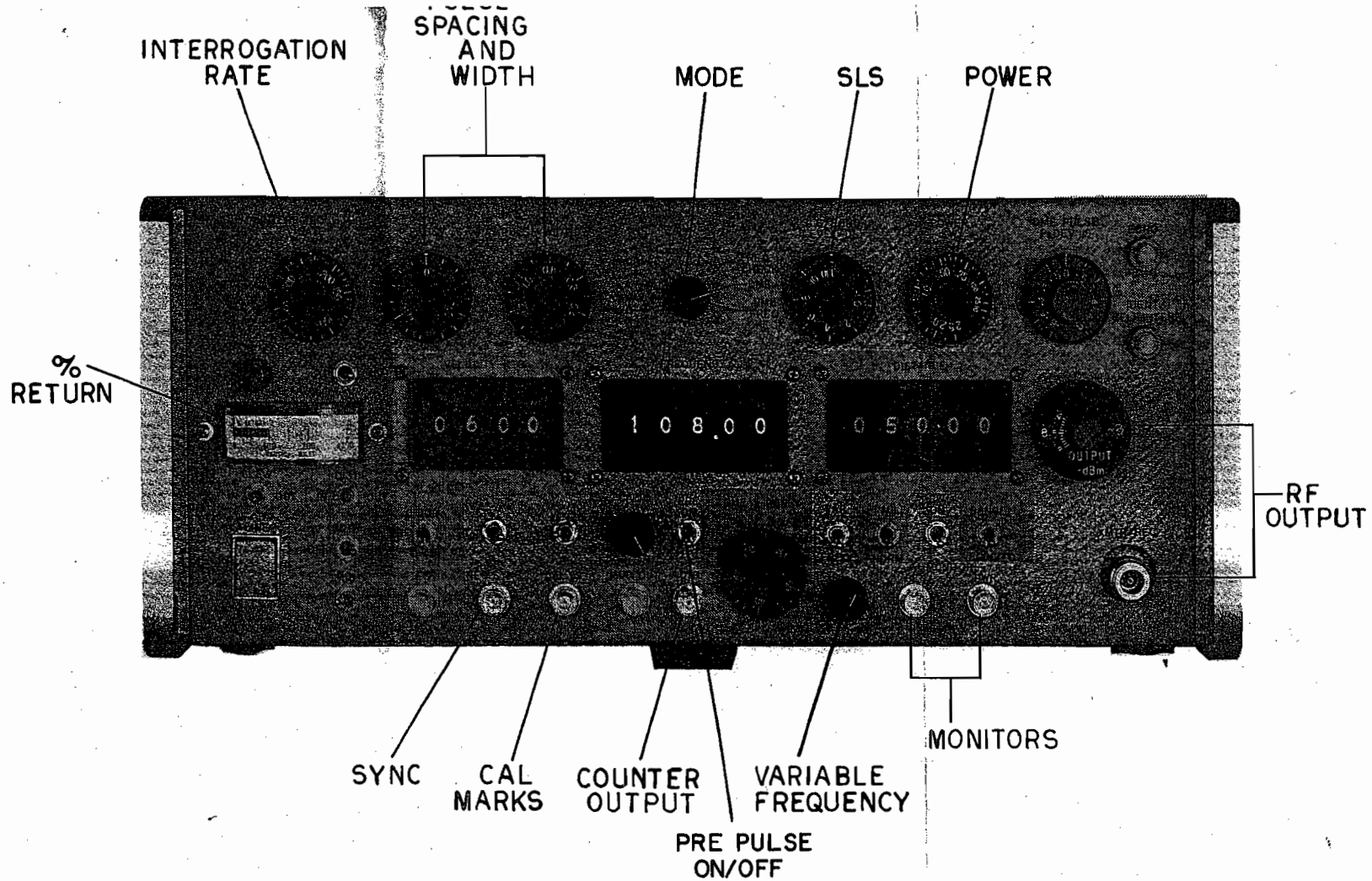

ATC-1200Y3 TRANSPONDER CONTROLS

Fig 4-2



ing the CAL  $\emptyset$  control will change the relative phasing of the CAL pulses to the reply pulses. These two simple tests indicate proper interconnection of equipment.

- A. Sensitivity - Minimum Trigger Level. Interrogate the Transponder at a rate that achieves a solid 100% return with the Output -dBm set to -50 dBm. (This may be other than the 500 PRF as set by paragraph 4-8d and 4-8e). Then reduce the R.F. Output level to achieve 90% return (or per manufacturer's manual) and read MTL reading on the Output -dBm control.

NOTE: The Transponder Percent Return is automatically displayed whenever a transponder is actively operating into the ATC-1200Y3.

- B. Decoder Limits. Vary the P3 DEV us control to determine receiver decoding limits as per manufacturer specs.
- C. SLS Calibration. Turn SLS/ECHO LEVEL -dB control clockwise to ON and set to -10dB. Increase amplitude of SLS pulse (P2) until transponder stops replying to interrogations. This is normally about -6dB - return to manufacturer specs.
- D. SLS (P2) Decoder Limits. With the SLS LEVEL control set to no reply from transponder, vary the P2 DEV us control until reply resumes. These + and - deviations are the SLS pulse gate limits.
- E. Transmitter Power. Turn SLS LEVEL control to OFF. Turn POWER KW control clockwise until reply pulses just do disappear into the base line of the scope display. Read power in KW directly from POWER KW control scale.

NOTE: Any point on the reply pulse waveform may be measured for power by placing that point on the display base line. Always read power from POWER KW control scale.

- F. Transmitter Frequency Check. See Figure 4-3. Rotate the POWER KW control until approximately 3 cm of reply pulse amplitude is displayed. Next set the ATC-1200Y3 mode switch to FREQ. CHECK. Interrogation

Adjust amplitude with Power - KW Control

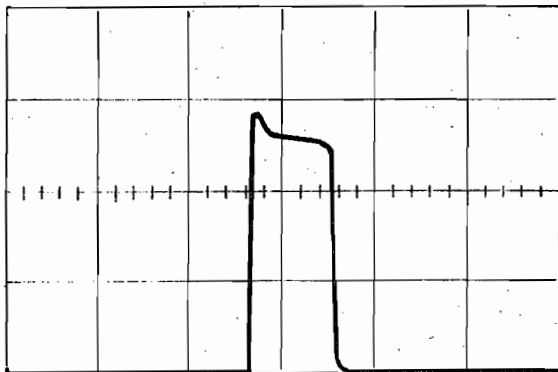

Normal  
Waveform.  
On-Frequency  
Presentation

Vert: .05 V/cm  
Horiz: .5 us/cm

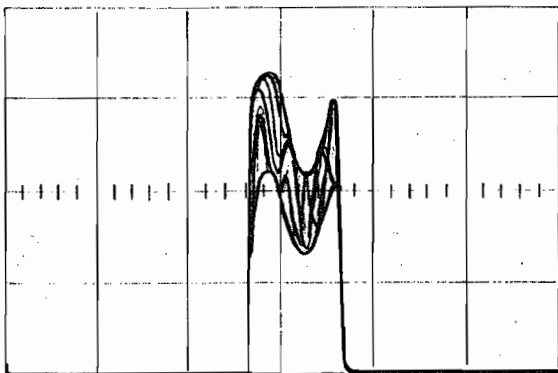

Off frequency  
approximately  
1 Mhz (high or  
low).

Vert: .05 V/cm  
Horiz: .5 us/cm

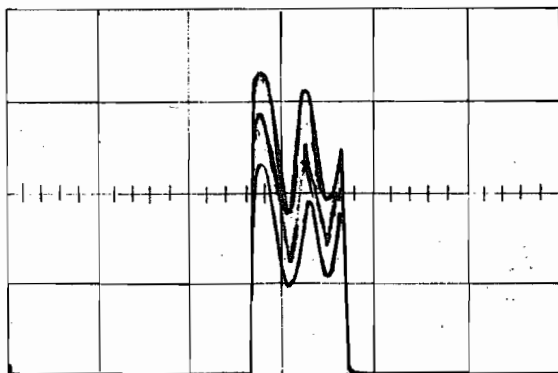

Off frequency  
approximately  
2 Mhz (high or  
low).

Vert: .05 V.cm  
Horiz: .5 us/cm

Figure 4-3

Transponder Frequency Check Waveforms

mode will automatically be on mode A. Select 1090 Gz on the FREQUENCY switch. Observe a beat pattern on the reply pulse display. This beat pattern is the result of heterodyning the ATC-1200Y3 signal generator and the transponder transmitter frequencies. Place the VAR or FREQ switch to VAR. Connect a counter to the CTR jack. Using the counter to determine the signal generator frequency sweep the frequency to 1090 MHz. A beat pattern very similar to that obtained in phase-locked operation should be displayed. Use the phase-locked mode to determine transmitter frequency to 1.0 MHz and the VAR mode to determine frequency to 500 kHz or closer, depending on operator experience and skill.

- G. Reply Pulse Spacing. Set CAL us switch to 1.45 then using the CAL  $\emptyset$  control align the leading edge of any calibrate pulse with the leading edge of P1 of reply. P2 of reply must then occur on the fifteenth CAL mark. Any code set into the transponder must have all pulses of that code occur exactly on the cal mark for that pulse's position. Ident pulse would occur on the eighteenth cal mark after P1. In addition to checking pulse spacing, the width of the 1.45us pulses is trimmed at the factory for approximately 0.45us the width of the reply pulses.
- H. A/C Mode Interlace. Set Mode switch to A/C. Observe reply pulse on oscilloscope. (Do not use alternate or chopped position). You should see reply pulses at positions A and C with a duty cycle of 50% each.
- I. Suppressor. Operate the ATC-1200Y3 and a transponder as outlined in paragraphs 4-8 through 4-12, observing the reply pulses on the oscilloscope. Next connect a cable between the test set suppressor output and the transponder. All reply pulses should cease while the suppressor pulse is applied to the transponder.
- J. Other Tests. Each manufacturer of ATC Transponder Equipment will have other tests for his specific requirements. Always utilize the manufacturer's manual and specifications when testing equipment, using the ATC-1200Y3 to provide the test parameters accurately and quickly.

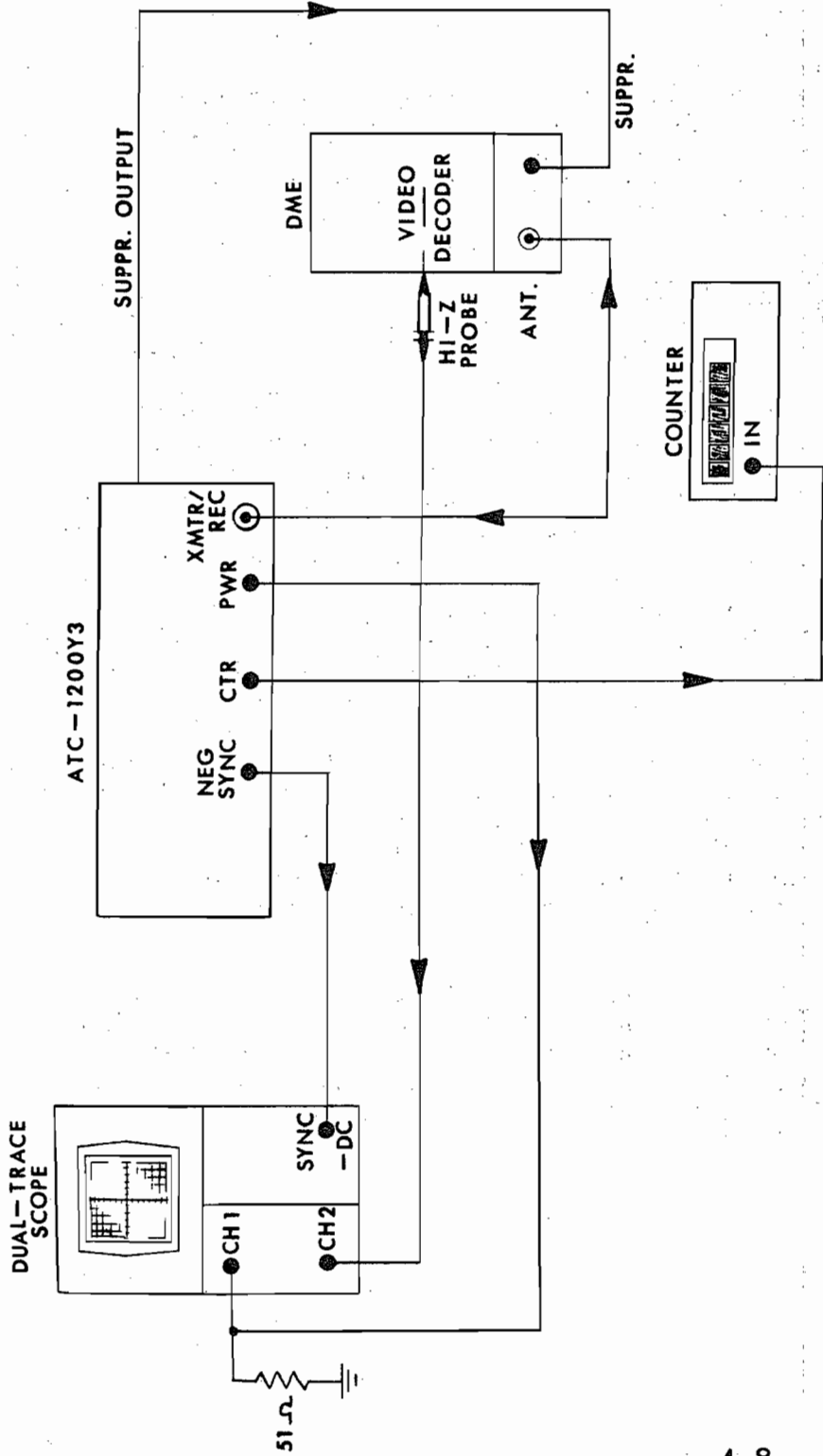
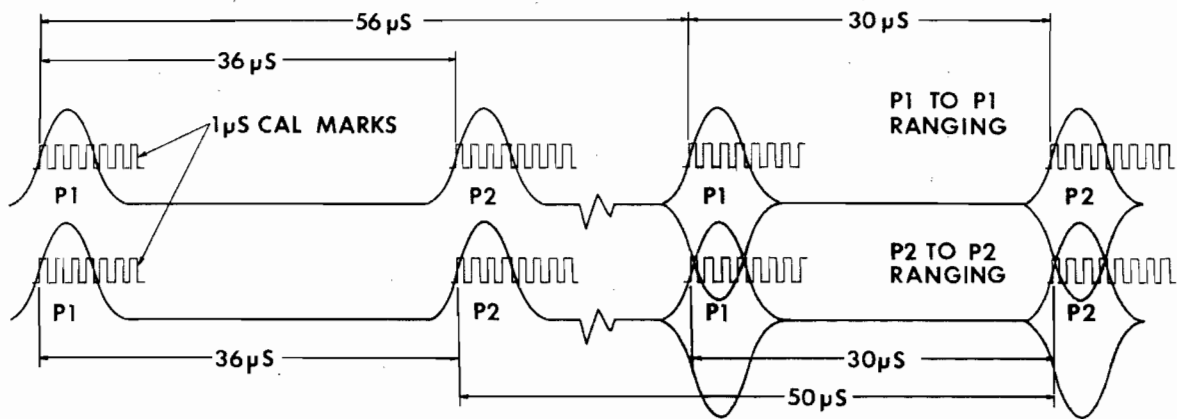
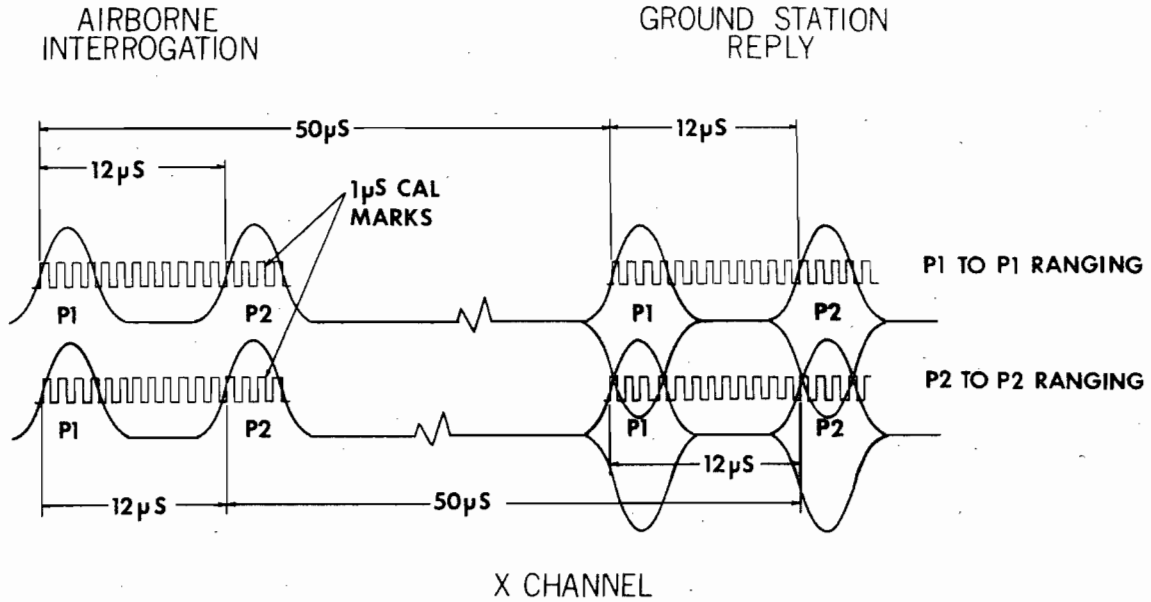
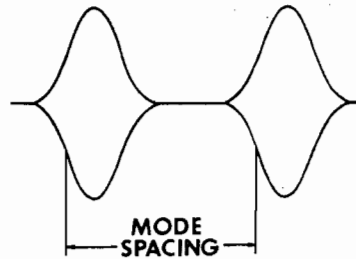
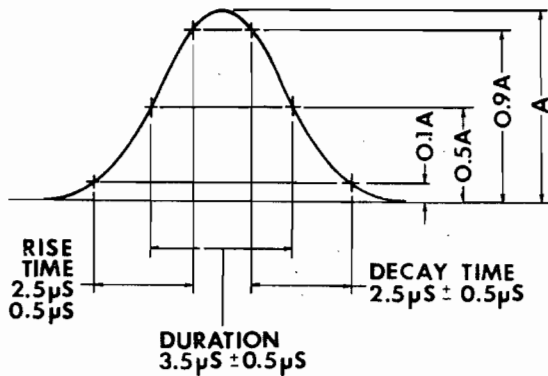

Figure 4-4  
Equipment Interconnections for DME Testing

# DME PULSE CHARACTERISTICS AND MODE SPACING



ALL TIMING MEASUREMENTS ARE GIVEN AT 0.5A.



	AIRBORNE INTERR.	GROUND STATION REPLY
MODE X	12 μs ± 0.5 μs	12 μs ± 0.5 μs
MODE Y	36 μs ± 0.5 μs	30 μs ± 0.5 μs

FIG. 4-4.1

4-14. DME OPERATION

4-15. Equipment Set-Up. The ATC-1200Y3 is connected to the oscilloscope and the DME under test as shown in Figure 4-4. All connecting cables are RG-58 50 ohm coax except the R.F. cable which is recommended to be RG-8 foam coax of shortest practical length.

4-16. To obtain accurate pulse wave shape determination the cable used for the monitor output should be terminated in 50 ohms.

4-17. Refer to Figure 4-5 and the following control settings for various DME tests. Each of the tests outlined in paragraph 4-21 is a typical test only and is therefore generalized. Always refer to the calibration and alignment manual for the DME being tested for the specific values, settings and tests to be performed.

4-18. ATC-1200Y3 Initial Control Settings

- a. MODE switch to DME
- b. FREQUENCY SWITCH to 108.00
- c. OUTPUT -dBm control to -50 dBm
- d. INTERR/SQUITTER RATE control to 270
- e. X1/X10 switch to X10
- f. SLS/ECHO LEVEL -dB to OFF
- g. POWER KW control full CCW
- h. DME PULSE P2 DEV us to 0.0
- i. VELOCITY-KTS switch to 0100 KTS
- j. DISTANCE switch to 020.00 N.M.
- k. PRF switch to 0-300 position.
- l. SQTR switch to ON
- m. IDENT switch to OFF
- n. SYNC switch to TO
- o. DME % REPLY to 100%
- p. VAR/FREQ switch to FREQ
- q. CW switch to OFF
- r. RANGE/VELOCITY switch to RANGE
- s. Rear Panel sync switch to SYNC SQUITTER
- t. R-NAV switch to OFF
- u. TACAN SIMULATION switch to OFF
- v. LINE switch ON (red pilot lamps on)
- w. Connect cables as shown in Figure 4-4

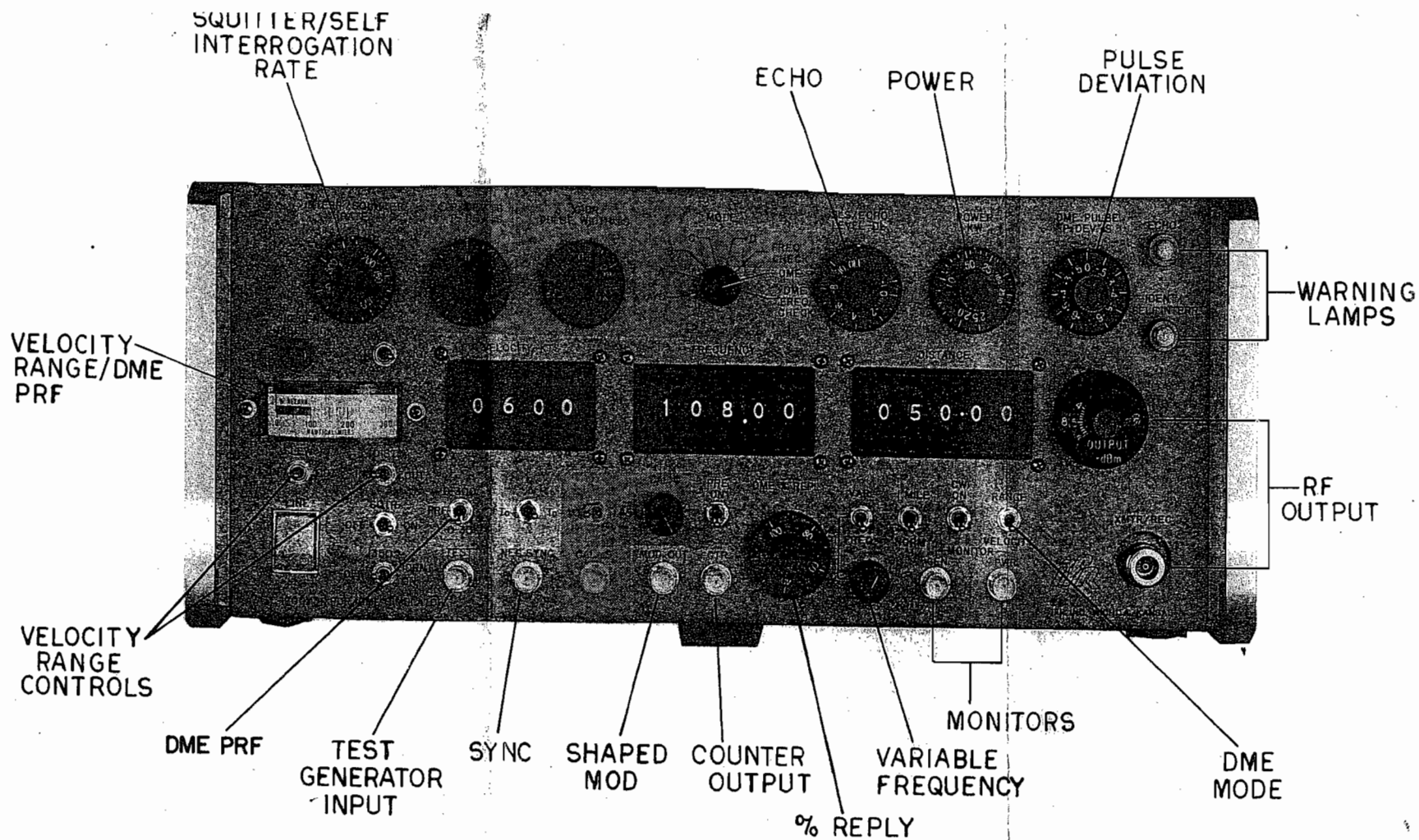

### ATC-1200Y3 DME CONTROLS

Fig 4-5

4-19. Oscilloscope Control Settings

- a. Vertical gain control to .05 V/cm
- b. Horiz. sweep to 2 us/cm
- c. Trigger input to EXT, NEG, DC
- d. Vertical mode to CHAN. A
- e. Intensity as desired for approximately a 25 PRF trigger rate

4-20. DME Control Settings.

- a. MODE switch to OPERATE (or activate the DME for normal service)
- b. FREQUENCY switch to 108.0
- c. FUNCTION switch to 0-30 N.M. range or distance readout.

4-21. Typical DME Tests.

4-22. With all controls and cables set according to paragraphs 4-17 through 4-19, the DME should be interrogating the ATC-1200Y3 and receiving squitter at a 2700 average PRF rate and fixed range replies at 20.0 N.M. Sync to the oscilloscope will coincide with each interrogation pulse from the DME, allowing observation of the transmitter waveform. The DME should "lock on" and hold at 20.0 NM with 0 KTS velocity. Clockwise rotation of the POWER - KW control will reduce the displayed amplitude of the transmitter pulses to zero (into the base line).

- A. Transmitter Power Output. Observe the transmitter interrogation pulses to the ATC-1200Y3 as in paragraph 4-21. Slowly rotate the POWER KW control clockwise until the peak of the pulses just disappears into the display's base line. Read the peak power in KW directly from the POWER KW control scale.
- B. Transmitter Pulse Spacing. Select the frequency specified by the manufacturer of your DME equipment for this test. Set the selected frequency on both the DME control head and the test set FREQUENCY switch. Adjust the POWER KW control for an oscilloscope display of pulses 4 to 6 cm in amplitude. Center the display vertically on the scope center graticule. The spacing from leading edge to leading edge as read on the center graticule should be 12.0us or 36.0us as shown in Figure 4-4.1.



Adjust Amplitude with Power - KW Control



Normal DME  
Interrogation  
Pulses - X Ch.

Vert: .05 V/cm  
Horiz: 5 us/cm

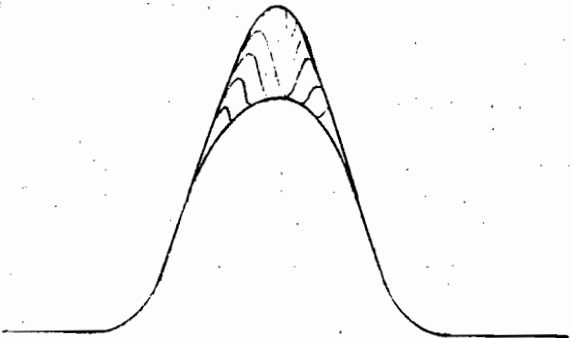

Approximately 1  
Mhz (high or low)  
from center channel  
frequency.

Vert: .05 V/cm  
Horiz: 2 us/cm

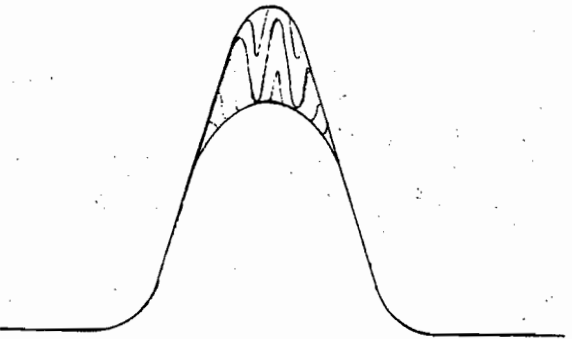

Approximately 2  
Mhz (high or low)  
from center channel  
frequency.

Vert: .05 V/cm  
Horiz: 2 us/cm

Figure 4-6

DME Frequency Check Waveforms

- C. Transmitter Frequency. The DME frequency check function is to give rapid verification that the DME is on the proper XMTR channel to within  $\pm 1$  MHz. Most DME sets must have an automatic standby circuit designed to allow the DME to search without receiving squitter. Refer to Figure 4-7 for the transmitter air to ground frequency for any given DME paired VOR frequency. Set the VOR frequency into the DME and select the Gz mode and the transmitter frequency on the FREQUENCY switch of the test set. Select DME FREQ CHECK on the mode switch and observe a beat pattern on the scope display. See Figures 4-6. The frequency switch may be paired in 1 MHz steps to verify channel center frequency, or operated in variable mode (using a counter to read out generator frequency).
- D. Receiver Sensitivity. One method is to adjust the Output -dBm control for a very low R.F. output of -115 dBm. The DME should be in standby. Slowly increase the output level until the DME locks on. Be sure squitter is ON at a PRF of 2700 and IDENT switch is OFF. Another method is to set the Output -dBm control to a value the DME should lock on at, and change frequency throughout the band. After each new frequency is selected the DME must lock on within a short time (perhaps 2 to 5 sec). Some manufacturers also specify a reduced % reply of 70 to 80%. Adjust the DME % REPLY control for desired reply efficiency.
- E. Receiver Selectivity. Set Output -dBm control to a solid lock on value (-60 to -70 dBm), and turn IDENT switch to 1350 cycle. Set VAR/FREQ switch to VAR and monitor generator frequency with an external counter. Manually vary the generator frequency above and below the channel the DME is set to. Refer to Figure 4-7. At the high and low selectivity limits, the ident tone should stop.
- F. Decoder Selectivity. With the DME operating normally into the ATC-1200Y3, turn IDENT switch to 1350 cycle. Vary the DME PULSE P2 DEV us control plus and minus 0.5us, 3, 4, 5, and 6us. At the decoder limits called for by the manufacturer, the tone should stop.

- G. Suppressor Pulse Output. Operate the DME into the ATC-1200Y3 in RANGE mode. Sync the scope by placing the sync switch in TD, rear panel switch in SYNC SQUITTER, and observe the DECODER OUTPUT from the DME receiver. Connect a cable from suppressor output (on rear of test set) to suppr. input of DME. During the time the cable is connected approximately 30% of the squitter pulses will be dropped by the decoder.
- H. Suppressor Pulse from DME. Operate the DME in the ATC-1200Y3 in RANGE mode, and select TO sync on test set. Observe the interrogation pulses on the scope. (See paragraph 4-22a). Next observe the suppr. output from the DME on channel B of scope using ALT vertical mode. A pulse must be present with each transmitted pulse. For amplitude and width refer to maintenance manual.
- I. Pulse Repetition Frequency. Place the PRF switch in 0-300 range. Cause the DME to search by any convenient means. While in search mode, read the interrogation PRF directly from the meter. Allow the DME to lock on. Place the PRF switch in 0-30 range and again read interrogation PRF directly from the meter. Note: ATC-1200Y3 must always be in RANGE mode to use the meter to measure PRF.
- J. Auto Standby. Place SQUITTER switch to OFF. Select a frequency for the DME different from the frequency set into the test set. The DME should go into standby mode. Next change the frequency of the test set to agree with the DME frequency. The DME should still be in standby with no squitter applied. Turning on squitter should start the DME searching. Note: some lower cost DME sets will search without squitter and have no standby circuits. Consult manufacturer's manual.
- K. Range Accuracy. Operate DME into ATC-1200Y3 in RANGE mode. Set squitter to on and IDENT off. Any range set into the DISTANCE switch should be read out by the DME indicator. Check with DME specifications for values to use for calibration.
- L. Velocity Accuracy. Operate DME into ATC-1200Y3 in VELOCITY mode. Set squitter to on and IDENT off. Press SLEW switch to the right until meter indicates

desired range. Set IN/OUT switch to track inbound or outbound. Any value set into velocity switch must be duplicated by DME. Check with DME specifications for values to use for velocity calibration.

- M. Memory Time. Allow DME to lock on to test set in either VELOCITY or RANGE mode. Squitter on and IDENT off. After DME has locked on for a short time (at least 20-30 sec.) turn IDENT switch to 1350 cycle which removes the reply to the DME. After the proper memory time has elapsed the DME should lose distance readout and begin searching.
- N. Echo Detection. For the relatively newer DME's that feature echo rejection, lock the DME on to the ATC-1200Y3 in RANGE mode at a distance of approximately 40 N.M. After a solid lock on has occurred, rotate the SLS/ECHO LEVEL -dB control clockwise to ON, then slowly increase the amplitude of the ECHO pulses until the DME unlocks from its original range and locks on immediately at 30 N.M. (the fixed ECHO distance). When this occurs stop rotating the control and read in dB the relative amplitude of the echo to regular reply pulses required for the DME to sense a new reply pulse.
- O. Audio Output. Placing the IDENT switch in 1350 cycle position at any time causes a solid tone to be heard in the receiver. Audio power output, IDENT filters, etc. may be checked in this manner.
- P. Other Tests
1. Mod. Output. The shaped DME reply pulses (and IDENT and SQUITTER) are available to modulate an I.F. signal generator or other purposes as needed.
  2. Tacan Simulation. There are cases where a DME presents ranging or tracking problems when tuned to a TACAN (VORTAC) station, but no problems when tuned to a VOR-DME station only. The ATC-1200Y3 simulates TACAN modulation, variable from 0 to 50%, to help in spotting these difficulties.

3. R-NAV. Area navigation computers which accept a two pulse input from the DME for range information can be directly tested from the ATC-1200Y3. The R-NAV two-pulse output is always available whenever the set is replying to valid interrogations. Those interrogations may come from the test set itself without a DME working into it by placing the R-NAV switch to ON position.
4. -1 Mile Switch. Some models of DME equipment utilize a drum distance readout which should have a lower limit of less than 0.0 N.M. The -1 mile function allows this setting to be checked. It also subtracts one mile from any other range set into the test set as well.

4-23. USE OF ATC-1200Y3 AS A GENERAL PURPOSE GENERATOR

- 4-24. From time to time it may be necessary or convenient to have an L-Band, crystal-controlled signal generator around the shop. By placing the CW switch ON the ATC-1200Y3 becomes such a generator. Of course it may also be used in continuously variable frequency mode, using an external counter to determine frequency. Either way, the R.F. output is leveled, pure, and selectively attenuated for any use.

Fig 4-7

## DME Frequency--VOR Frequency Pairing

VOR FREQ (MHz)	DME RCVR (GRD TO AIR)	DME XMTR (AIR TO GND)	TACAN CH (SPACING)	VOR FREQ (MHz)	DME RCVR (GRD TO AIR)	DME XMTR (AIR TO GND)	TACAN CH (SPACING)	VOR FREQ (MHz)	DME RCVR (GRD TO AIR)	DME XMTR (AIR TO GND)	TACAN CH (SPACING)
108.00	978	1041	17X	112.20	1020	1083	59X	116.40	1198	1135	111X
108.05	1104	1041	17Y	112.25	1146	1083	59Y	116.45	1072	1135	111Y
108.10	979	1042	18X	112.30	1157	1094	70X	116.50	1199	1136	112X
108.15	1105	1042	18Y	112.35	1051	1094	70Y	116.55	1073	1136	112Y
108.20	980	1043	19X	112.40	1158	1095	71X	116.60	1200	1137	113X
108.25	1106	1043	19Y	112.45	1032	1095	71Y	116.65	1074	1137	113Y
108.30	981	1044	20X	112.50	1159	1096	72X	116.70	1201	1138	114X
108.35	1107	1044	20Y	112.55	1033	1096	72Y	116.75	1075	1138	114Y
108.40	982	1045	21X	112.60	1160	1097	73X	116.80	1202	1139	115X
108.45	1108	1045	21Y	112.65	1094	1097	73Y	116.85	1076	1139	115Y
108.50	983	1046	22X	112.70	1161	1098	74X	116.90	1203	1140	116X
108.55	1109	1046	22Y	112.75	1035	1098	74Y	116.95	1077	1140	116Y
108.60	984	1047	23X	112.80	1162	1099	75X	117.00	1204	1141	117X
108.65	1110	1047	23Y	112.85	1036	1099	75Y	117.05	1078	1141	117Y
108.70	985	1048	24X	112.90	1163	1100	76X	117.10	1205	1142	118X
108.75	1111	1048	24Y	112.95	1037	1100	76Y	117.15	1079	1142	118Y
108.80	986	1049	25X	113.00	1164	1101	77X	117.20	1206	1143	119X
108.85	1112	1049	25Y	113.05	1038	1101	77Y	117.25	1080	1143	119Y
108.90	987	1050	26X	113.10	1165	1102	78X	117.30	1207	1144	120X
108.95	1113	1050	26Y	113.15	1039	1102	78Y	117.35	1081	1144	120Y
109.00	988	1051	27X	113.20	1166	1103	79X	117.40	1208	1145	121X
109.05	1114	1051	27Y	113.25	1040	1103	79Y	117.45	1082	1145	121Y
109.10	989	1052	28X	113.30	1167	1104	80X	117.50	1209	1146	122X
109.15	1115	1052	28Y	113.35	1041	1104	80Y	117.55	1083	1146	122Y
109.20	990	1053	29X	113.40	1168	1105	81X	117.60	1210	1147	123X
109.25	1116	1053	29Y	113.45	1042	1105	81Y	117.65	1084	1147	123Y
109.30	991	1054	30X	113.50	1169	1106	82X	117.70	1211	1148	124X
109.35	1117	1054	30Y	113.55	1043	1106	82Y	117.75	1085	1148	124Y
109.40	992	1055	31X	113.60	1170	1107	83X	117.80	1212	1149	125X
109.45	1118	1055	31Y	113.65	1044	1107	83Y	117.85	1086	1149	125Y
109.50	993	1056	32X	113.70	1171	1108	84X	117.90	1213	1150	126X
109.55	1119	1056	32Y	113.75	1045	1108	84Y	117.95	1087	1150	126Y
109.60	994	1057	33X	113.80	1172	1109	85X	133.30	1021	1084	60X
109.65	1120	1057	33Y	113.85	1046	1109	85Y	133.35	1147	1084	60Y
109.70	995	1058	34X	113.90	1173	1110	86X	133.40	1022	1085	61X
109.75	1121	1058	34Y	113.95	1047	1110	86Y	133.45	1148	1085	61Y
109.80	996	1059	35X	114.00	1174	1111	87X	133.50	1023	1086	62X
109.85	1122	1059	35Y	114.05	1048	1111	87Y	133.55	1149	1086	62Y
109.90	997	1060	36X	114.10	1175	1112	88X	133.60	1024	1087	63X
109.95	1123	1060	36Y	114.15	1049	1112	88Y	133.65	1150	1087	63Y
110.00	998	1061	37X	114.20	1176	1113	89X	133.70	1151	1088	64X
110.05	1124	1061	37Y	114.25	1050	1113	89Y	133.75	1025	1088	64Y
110.10	999	1062	38X	114.30	1177	1114	90X	133.80	1152	1089	65X
110.15	1125	1062	38Y	114.35	1051	1114	90Y	133.85	1026	1089	65Y
110.20	1000	1063	39X	114.40	1178	1115	91X	133.90	1153	1090	66X
110.25	1126	1063	39Y	114.45	1052	1115	91Y	133.95	1027	1090	66Y
110.30	1001	1064	40X	114.50	1179	1116	92X	134.00	1154	1091	67X
110.35	1127	1064	40Y	114.55	1053	1116	92Y	134.05	1028	1091	67Y
110.40	1002	1065	41X	114.60	1180	1117	93X	134.10	1155	1092	68X
110.45	1128	1065	41Y	114.65	1054	1117	93Y	134.15	1029	1092	68Y
110.50	1003	1066	42X	114.70	1181	1118	94X	134.20	1156	1093	69X
110.55	1129	1066	42Y	114.75	1055	1118	94Y	134.25	1030	1093	69Y
110.60	1004	1067	43X	114.80	1182	1119	95X	134.30	1031	1025	1X
110.65	1130	1067	43Y	114.85	1056	1119	95Y	134.35	1088	1025	1Y
110.70	1005	1068	44X	114.90	1183	1120	96X	134.40	1032	1026	2X
110.75	1131	1068	44Y	114.95	1057	1120	96Y	134.45	1089	1026	2Y
110.80	1006	1069	45X	115.00	1184	1121	97X	134.50	1033	1027	3X
110.85	1132	1069	45Y	115.05	1058	1121	97Y	134.55	1090	1027	3Y
110.90	1007	1070	46X	115.10	1185	1122	98X	134.60	1034	1028	4X
110.95	1133	1070	46Y	115.15	1059	1122	98Y	134.65	1091	1028	4Y
111.00	1008	1071	47X	115.20	1186	1123	99X	134.70	1035	1029	5X
111.05	1134	1071	47Y	115.25	1060	1123	99Y	134.75	1092	1029	5Y
111.10	1009	1072	48X	115.30	1187	1124	100X	134.80	1036	1030	6X
111.15	1135	1072	48Y	115.35	1061	1124	100Y	134.85	1093	1030	6Y
111.20	1010	1073	49X	115.40	1188	1125	101X	134.90	1037	1031	7X
111.25	1136	1073	49Y	115.45	1062	1125	101Y	134.95	1094	1031	7Y
111.30	1011	1074	50X	115.50	1189	1126	102X	135.00	1038	1032	8X
111.35	1137	1074	50Y	115.55	1063	1126	102Y	135.05	1095	1032	8Y
111.40	1012	1075	51X	115.60	1190	1127	103X	135.10	1039	1033	9X
111.45	1138	1075	51Y	115.65	1064	1127	103Y	135.15	1096	1033	9Y
111.50	1013	1076	52X	115.70	1191	1128	104X	135.20	1040	1034	10X
111.55	1139	1076	52Y	115.75	1065	1128	104Y	135.25	1097	1034	10Y
111.60	1014	1077	53X	115.80	1192	1129	105X	135.30	1041	1035	11X
111.65	1140	1077	53Y	115.85	1066	1129	105Y	135.35	1098	1035	11Y
111.70	1015	1078	54X	115.90	1193	1130	106X	135.40	1042	1036	12X
111.75	1141	1078	54Y	115.95	1067	1130	106Y	135.45	1099	1036	12Y
111.80	1016	1079	55X	116.00	1194	1131	107X	135.50	1043	1037	13X
111.85	1142	1079	55Y	116.05	1068	1131	107Y	135.55	1100	1037	13Y
111.90	1017	1080	56X	116.10	1195	1132	108X	135.60	1044	1038	14X
111.95	1143	1080	56Y	116.15	1069	1132	108Y	135.65	1101	1038	14Y
112.00	1018	1081	57X	116.20	1196	1133	109X	135.70	1045	1039	15X
112.05	1144	1081	57Y	116.25	1070	1133	109Y	135.75	1102	1039	15Y
112.10	1019	1082	58X	116.30	1197	1134	110X	135.80	1046	1040	16X
112.15	1145	1082	58Y	116.35	1071	1134	110Y	135.85	1103	1040	16Y

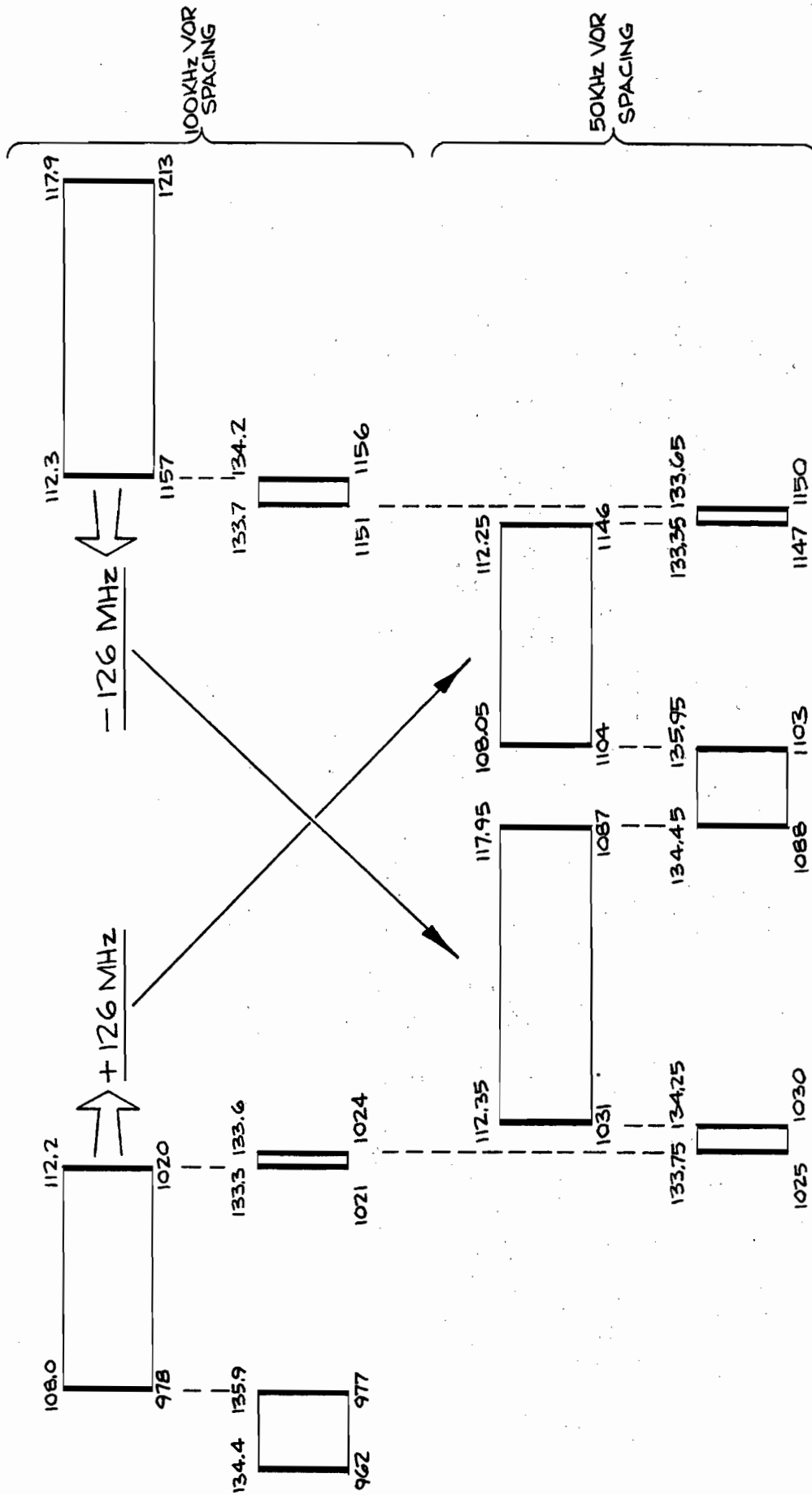

FIGURE 4-8.  
DME GROUND TO AIR FREQUENCY CHANNELING





### ALTITUDE TRANSMISSION CODE CHART

RANGE	PULSE POSITION										
Altitude in Thousands	D <sub>2</sub>	D <sub>4</sub> and SPI	A <sub>1</sub>	A <sub>2</sub>	A <sub>4</sub>	B <sub>1</sub>	B <sub>2</sub>	B <sub>4</sub>	C <sub>1</sub>	C <sub>2</sub>	C <sub>4</sub>
-1.0	0	0	0	0	0	0	0	0	0	1	0
-0.9	0	0	0	0	0	0	0	0	1	1	0
-0.8	0	0	0	0	0	0	0	0	1	0	0
-0.7	0	0	0	0	0	0	0	1	1	0	0
-0.6	0	0	0	0	0	0	0	1	1	1	0
-0.5	0	0	0	0	0	0	0	1	0	1	0
-0.4	0	0	0	0	0	0	0	1	0	1	1
-0.3	0	0	0	0	0	0	0	1	0	0	1
-0.2	0	0	0	0	0	0	1	1	0	0	1
-0.1	0	0	0	0	0	0	1	1	0	1	1
0.0	0	0	0	0	0	0	1	1	0	1	0
0.1	0	0	0	0	0	0	1	1	1	1	0
0.2	0	0	0	0	0	0	1	1	1	0	0
0.3	0	0	0	0	0	0	1	0	1	0	0
0.4	0	0	0	0	0	0	1	0	1	1	0
0.5	0	0	0	0	0	0	1	0	0	1	0
0.6	0	0	0	0	0	0	1	0	0	1	1
0.7	0	0	0	0	0	0	1	0	0	0	1
0.8	0	0	0	0	0	1	1	0	0	0	1
0.9	0	0	0	0	0	1	1	0	0	1	1
1.0	0	0	0	0	0	1	1	0	0	1	0
1.1	0	0	0	0	0	1	1	0	1	1	0
1.2	0	0	0	0	0	1	1	0	1	0	0
1.3	0	0	0	0	0	1	1	1	1	0	0
1.4	0	0	0	0	0	1	1	1	1	1	0
1.5	0	0	0	0	0	1	1	1	0	1	0
1.6	0	0	0	0	0	1	1	1	0	1	1
1.7	0	0	0	0	0	1	1	1	0	0	1

RANGE	PULSE POSITION										
	Altitude in Thousands	D <sub>2</sub>	D <sub>4</sub> and SPI	A <sub>1</sub>	A <sub>2</sub>	A <sub>4</sub>	B <sub>1</sub>	B <sub>2</sub>	B <sub>4</sub>	C <sub>1</sub>	C <sub>2</sub>
1.8	0	0	0	0	0	1	0	1	0	0	1
1.9	0	0	0	0	0	1	0	1	0	1	1
2.0	0	0	0	0	0	1	0	1	0	1	0
2.1	0	0	0	0	0	1	0	1	1	1	0
2.2	0	0	0	0	0	1	0	1	1	0	0
2.3	0	0	0	0	0	1	0	0	1	0	0
2.4	0	0	0	0	0	1	0	0	1	1	0
2.5	0	0	0	0	0	1	0	0	0	1	0
2.6	0	0	0	0	0	1	0	0	0	1	1
2.7	0	0	0	0	0	1	0	0	0	0	1
2.8	0	0	0	0	1	1	0	0	0	0	1
2.9	0	0	0	0	1	1	0	0	0	1	1
3.0	0	0	0	0	1	1	0	0	0	1	0
3.1	0	0	0	0	1	1	0	0	1	1	0
3.2	0	0	0	0	1	1	0	0	1	0	0
3.3	0	0	0	0	1	1	0	1	1	0	0
3.4	0	0	0	0	1	1	0	1	1	1	0
3.5	0	0	0	0	1	1	0	1	0	1	0
3.6	0	0	0	0	1	1	0	1	0	1	1
3.7	0	0	0	0	1	1	0	1	0	0	1
3.8	0	0	0	0	1	1	1	1	0	0	1
3.9	0	0	0	0	1	1	1	1	0	1	1
4.0	0	0	0	0	1	1	1	1	0	1	0
4.1	0	0	0	0	1	1	1	1	1	1	0
4.2	0	0	0	0	1	1	1	1	1	0	0
4.3	0	0	0	0	1	1	1	0	1	0	0
4.4	0	0	0	0	1	1	1	0	1	1	0
4.5	0	0	0	0	1	1	1	0	0	1	0
4.6	0	0	0	0	1	1	1	0	0	1	1
4.7	0	0	0	0	1	1	1	0	0	0	1
4.8	0	0	0	0	1	0	1	0	0	0	1
4.9	0	0	0	0	1	0	1	0	0	1	1
5.0	0	0	0	0	1	0	1	0	0	1	0
5.1	0	0	0	0	1	0	1	0	1	1	0
5.2	0	0	0	0	1	0	1	0	1	0	0

RANGE	PULSE POSITION										
Altitude in Thousands	D <sub>2</sub>	D <sub>4</sub> and SPI	A <sub>1</sub>	A <sub>2</sub>	A <sub>4</sub>	B <sub>1</sub>	B <sub>2</sub>	B <sub>4</sub>	C <sub>1</sub>	C <sub>2</sub>	C <sub>4</sub>
5.3	0	0	0	0	1	0	1	1	1	0	0
5.4	0	0	0	0	1	0	1	1	1	1	0
5.5	0	0	0	0	1	0	1	1	0	1	0
5.6	0	0	0	0	1	0	1	1	0	1	1
5.7	0	0	0	0	1	0	1	1	0	0	1
5.8	0	0	0	0	1	0	0	1	0	0	1
5.9	0	0	0	0	1	0	0	1	0	1	1
6.0	0	0	0	0	1	0	0	1	0	1	0
6.1	0	0	0	0	1	0	0	1	1	1	0
6.2	0	0	0	0	1	0	0	1	1	0	0
6.3	0	0	0	0	1	0	0	0	1	0	0
6.4	0	0	0	0	1	0	0	0	1	1	0
6.5	0	0	0	0	1	0	0	0	0	1	0
6.6	0	0	0	0	1	0	0	0	0	1	1
6.7	0	0	0	0	1	0	0	0	0	0	1
6.8	0	0	0	1	1	0	0	0	0	0	1
6.9	0	0	0	1	1	0	0	0	0	1	1
7.0	0	0	0	1	1	0	0	0	0	1	0
7.1	0	0	0	1	1	0	0	0	1	1	0
7.2	0	0	0	1	1	0	0	0	1	0	0
7.3	0	0	0	1	1	0	0	1	1	0	0
7.4	0	0	0	1	1	0	0	1	1	1	0
7.5	0	0	0	1	1	0	0	1	0	1	0
7.6	0	0	0	1	1	0	0	1	0	1	1
7.7	0	0	0	1	1	0	0	1	0	0	1
7.8	0	0	0	1	1	0	1	1	0	0	1
7.9	0	0	0	1	1	0	1	1	0	1	1
8.0	0	0	0	1	1	0	1	1	0	1	0
8.1	0	0	0	1	1	0	1	1	1	1	0
8.2	0	0	0	1	1	0	1	1	1	0	0

RANGE	PULSE POSITION										
Altitude in Thousands	D	D and SPI	A <sub>1</sub>	A <sub>2</sub>	A <sub>4</sub>	B <sub>1</sub>	B <sub>2</sub>	B <sub>4</sub>	C <sub>1</sub>	C <sub>2</sub>	C <sub>4</sub>
8.3	0	0	0	1	1	0	1	0	1	0	0
8.4	0	0	0	1	1	0	1	0	1	1	0
8.5	0	0	0	1	1	0	1	0	0	1	0
8.6	0	0	0	1	1	0	1	0	0	1	1
8.7	0	0	0	1	1	0	1	0	0	0	1
8.8	0	0	0	1	1	1	1	0	0	0	1
8.9	0	0	0	1	1	1	1	0	0	1	1
9.0	0	0	0	1	1	1	1	0	0	1	0
9.1	0	0	0	1	1	1	1	0	1	1	0
9.2	0	0	0	1	1	1	1	0	1	0	0
9.3	0	0	0	1	1	1	1	1	1	0	0
9.4	0	0	0	1	1	1	1	1	1	1	0
9.5	0	0	0	1	1	1	1	1	0	1	0
9.6	0	0	0	1	1	1	1	1	0	1	1
9.7	0	0	0	1	1	1	1	1	0	0	1
9.8	0	0	0	1	1	1	0	1	0	0	1
9.9	0	0	0	1	1	1	0	1	0	1	1
10.0	0	0	0	1	1	1	0	1	0	1	0
10.1	0	0	0	1	1	1	0	1	1	1	0
10.2	0	0	0	1	1	1	0	1	1	0	0
10.3	0	0	0	1	1	1	0	0	1	0	0
10.4	0	0	0	1	1	1	0	0	1	1	0
10.5	0	0	0	1	1	1	0	0	0	1	0
10.6	0	0	0	1	1	1	0	0	0	1	1
10.7	0	0	0	1	1	1	0	0	0	0	1
10.8	0	0	0	1	0	1	0	0	0	0	1
10.9	0	0	0	1	0	1	0	0	0	1	1
11.0	0	0	0	1	0	1	0	0	0	1	0
11.1	0	0	0	1	0	1	0	0	1	1	0
11.2	0	0	0	1	0	1	0	0	1	0	0

RANGE	PULSE POSITION										
Altitude in Thousands	D <sub>2</sub>	D <sub>4</sub> and SPI	A <sub>1</sub>	A <sub>2</sub>	A <sub>4</sub>	B <sub>1</sub>	B <sub>2</sub>	B <sub>4</sub>	C <sub>1</sub>	C <sub>2</sub>	C <sub>4</sub>
11.3	0	0	0	1	0	1	0	1	1	0	0
11.4	0	0	0	1	0	1	0	1	1	1	0
11.5	0	0	0	1	0	1	0	1	0	1	0
11.6	0	0	0	1	0	1	0	1	0	1	1
11.7	0	0	0	1	0	1	0	1	0	0	1
11.8	0	0	0	1	0	1	1	1	0	0	1
11.9	0	0	0	1	0	1	1	1	0	1	1
12.0	0	0	0	1	0	1	1	1	0	1	0
12.1	0	0	0	1	0	1	1	1	1	1	0
12.2	0	0	0	1	0	1	1	1	1	0	0
12.3	0	0	0	1	0	1	1	0	1	0	0
12.4	0	0	0	1	0	1	1	0	1	1	0
12.5	0	0	0	1	0	1	1	0	0	1	0
12.6	0	0	0	1	0	1	1	0	0	1	1
12.7	0	0	0	1	0	1	1	0	0	0	1
12.8	0	0	0	1	0	0	1	0	0	0	1
12.9	0	0	0	1	0	0	1	0	0	1	1
13.0	0	0	0	1	0	0	1	0	0	1	0
13.1	0	0	0	1	0	0	1	0	1	1	0
13.2	0	0	0	1	0	0	1	0	1	0	0
13.3	0	0	0	1	0	0	1	1	1	0	0
13.4	0	0	0	1	0	0	1	1	1	1	0
13.5	0	0	0	1	0	0	1	1	0	1	0
13.6	0	0	0	1	0	0	1	1	0	1	1
13.7	0	0	0	1	0	0	1	1	0	0	1
13.8	0	0	0	1	0	0	0	1	0	0	1
13.9	0	0	0	1	0	0	0	1	0	1	1
14.0	0	0	0	1	0	0	0	1	0	1	0
14.1	0	0	0	1	0	0	0	1	1	1	0
14.2	0	0	0	1	0	0	0	1	1	0	0

RANGE	PULSE POSITION										
	Altitude in Thousands	D <sub>2</sub>	D <sub>4</sub> and SPI	A <sub>1</sub>	A <sub>2</sub>	A <sub>4</sub>	B <sub>1</sub>	B <sub>2</sub>	B <sub>4</sub>	C <sub>1</sub>	C <sub>2</sub>
14.3	0	0	0	1	0	0	0	0	1	0	0
14.4	0	0	0	1	0	0	0	0	1	1	0
14.5	0	0	0	1	0	0	0	0	0	1	0
14.6	0	0	0	1	0	0	0	0	0	1	1
14.7	0	0	0	1	0	0	0	0	0	0	1
14.8	0	0	1	1	0	0	0	0	0	0	1
14.9	0	0	1	1	0	0	0	0	0	1	1
15.0	0	0	1	1	0	0	0	0	0	1	0
15.1	0	0	1	1	0	0	0	0	1	1	0
15.2	0	0	1	1	0	0	0	0	1	0	0
15.3	0	0	1	1	0	0	0	1	1	0	0
15.4	0	0	1	1	0	0	0	1	1	1	0
15.5	0	0	1	1	0	0	0	1	0	1	0
15.6	0	0	1	1	0	0	0	1	0	1	1
15.7	0	0	1	1	0	0	0	1	0	0	1
15.8	0	0	1	1	0	0	1	1	0	0	1
15.9	0	0	1	1	0	0	1	1	0	1	1
16.0	0	0	1	1	0	0	1	1	0	1	0
16.1	0	0	1	1	0	0	1	1	1	1	0
16.2	0	0	1	1	0	0	1	1	1	0	0
16.3	0	0	1	1	0	0	1	0	1	0	0
16.4	0	0	1	1	0	0	1	0	1	1	0
16.5	0	0	1	1	0	0	1	0	0	1	0
16.6	0	0	1	1	0	0	1	0	0	1	1
16.7	0	0	1	1	0	0	1	0	0	0	1
16.8	0	0	1	1	0	1	1	0	0	0	1
16.9	0	0	1	1	0	1	1	0	0	1	1
17.0	0	0	1	1	0	1	1	0	0	1	0
17.1	0	0	1	1	0	1	1	0	1	1	0
17.2	0	0	1	1	0	1	1	0	1	0	0

RANGE	PULSE POSITION										
Altitude in Thousands	D <sub>2</sub>	D <sub>4</sub> and SPI	A <sub>1</sub>	A <sub>2</sub>	A <sub>4</sub>	B <sub>1</sub>	B <sub>2</sub>	B <sub>4</sub>	C <sub>1</sub>	C <sub>2</sub>	C <sub>4</sub>
17.3	0	0	1	1	0	1	1	1	1	0	0
17.4	0	0	1	1	0	1	1	1	1	1	0
17.5	0	0	1	1	0	1	1	1	0	1	0
17.6	0	0	1	1	0	1	1	1	0	1	1
17.7	0	0	1	1	0	1	1	1	0	0	1
17.8	0	0	1	1	0	1	0	1	0	0	1
17.9	0	0	1	1	0	1	0	1	0	1	1
18.0	0	0	1	1	0	1	0	1	0	1	0
18.1	0	0	1	1	0	1	0	1	1	1	0
18.2	0	0	1	1	0	1	0	1	1	0	0
18.3	0	0	1	1	0	1	0	0	1	0	0
18.4	0	0	1	1	0	1	0	0	1	1	0
18.5	0	0	1	1	0	1	0	0	0	1	0
18.6	0	0	1	1	0	1	0	0	0	1	1
18.7	0	0	1	1	0	1	0	0	0	0	1
18.8	0	0	1	1	1	1	0	0	0	0	1
18.9	0	0	1	1	1	1	0	0	0	1	1
19.0	0	0	1	1	1	1	0	0	0	1	0
19.1	0	0	1	1	1	1	0	0	1	1	0
19.2	0	0	1	1	1	1	0	0	1	0	0
19.3	0	0	1	1	1	1	0	1	1	0	0
19.4	0	0	1	1	1	1	0	1	1	1	0
19.5	0	0	1	1	1	1	0	1	0	1	0
19.6	0	0	1	1	1	1	0	1	0	1	1
19.7	0	0	1	1	1	1	0	1	0	0	1
19.8	0	0	1	1	1	1	1	1	0	0	1
19.9	0	0	1	1	1	1	1	1	0	1	1
20.0	0	0	1	1	1	1	1	1	0	1	0
20.1	0	0	1	1	1	1	1	1	1	1	0
20.2	0	0	1	1	1	1	1	1	1	0	0

RANGE	PULSE POSITION										
	D <sub>2</sub>	D <sub>4</sub> and SPI	A <sub>1</sub>	A <sub>2</sub>	A <sub>4</sub>	B <sub>1</sub>	B <sub>2</sub>	B <sub>4</sub>	C <sub>1</sub>	C <sub>2</sub>	C <sub>4</sub>
20.3	0	0	1	1	1	1	1	0	1	0	0
20.4	0	0	1	1	1	1	1	0	1	1	0
20.5	0	0	1	1	1	1	1	0	0	1	0
20.6	0	0	1	1	1	1	1	0	0	1	1
20.7	0	0	1	1	1	1	1	0	0	0	1
20.8	0	0	1	1	1	0	1	0	0	0	1
20.9	0	0	1	1	1	0	1	0	0	1	1
21.0	0	0	1	1	1	0	1	0	0	1	0
21.1	0	0	1	1	1	0	1	0	1	1	0
21.2	0	0	1	1	1	0	1	0	1	0	0
21.3	0	0	1	1	1	0	1	1	1	0	0
21.4	0	0	1	1	1	0	1	1	1	1	0
21.5	0	0	1	1	1	0	1	1	0	1	0
21.6	0	0	1	1	1	0	1	1	0	1	1
21.7	0	0	1	1	1	0	1	1	0	0	1
21.8	0	0	1	1	1	0	0	1	0	0	1
21.9	0	0	1	1	1	0	0	1	0	1	1
22.0	0	0	1	1	1	0	0	1	0	1	0
22.1	0	0	1	1	1	0	0	1	1	1	0
22.2	0	0	1	1	1	0	0	1	1	0	0
22.3	0	0	1	1	1	0	0	0	1	0	0
22.4	0	0	1	1	1	0	0	0	1	1	0
22.5	0	0	1	1	1	0	0	0	0	1	0
22.6	0	0	1	1	1	0	0	0	0	1	1
22.7	0	0	1	1	1	0	0	0	0	0	1
22.8	0	0	1	0	1	0	0	0	0	0	1
22.9	0	0	1	0	1	0	0	0	0	1	1
23.0	0	0	1	0	1	0	0	0	0	1	0
23.1	0	0	1	0	1	0	0	0	1	1	0
23.2	0	0	1	0	1	0	0	0	1	0	0



RANGE	PULSE POSITION										
Altitude in Thousands	D <sub>2</sub>	D <sub>4</sub> and SPI	A <sub>1</sub>	A <sub>2</sub>	A <sub>4</sub>	B <sub>1</sub>	B <sub>2</sub>	B <sub>4</sub>	C <sub>1</sub>	C <sub>2</sub>	C <sub>4</sub>
23.3	0	0	1	0	1	0	0	1	1	0	0
23.4	0	0	1	0	1	0	0	1	1	1	0
23.5	0	0	1	0	1	0	0	1	0	1	0
23.6	0	0	1	0	1	0	0	1	0	1	1
23.7	0	0	1	0	1	0	0	1	0	0	1
23.8	0	0	1	0	1	0	1	1	0	0	1
23.9	0	0	1	0	1	0	1	1	0	1	1
24.0	0	0	1	0	1	0	1	1	0	1	0
24.1	0	0	1	0	1	0	1	1	1	1	0
24.2	0	0	1	0	1	0	1	1	1	0	0
24.3	0	0	1	0	1	0	1	0	1	0	0
24.4	0	0	1	0	1	0	1	0	1	1	0
24.5	0	0	1	0	1	0	1	0	0	1	0
24.6	0	0	1	0	1	0	1	0	0	1	1
24.7	0	0	1	0	1	0	1	0	0	0	1
24.8	0	0	1	0	1	1	1	0	0	0	1
24.9	0	0	1	0	1	1	1	0	0	1	1
25.0	0	0	1	0	1	1	1	0	0	1	0
25.1	0	0	1	0	1	1	1	0	1	1	0
25.2	0	0	1	0	1	1	1	0	1	0	0
25.3	0	0	1	0	1	1	1	1	1	0	0
25.4	0	0	1	0	1	1	1	1	1	1	0
25.5	0	0	1	0	1	1	1	1	0	1	0
25.6	0	0	1	0	1	1	1	1	0	1	1
25.7	0	0	1	0	1	1	1	1	0	0	1
25.8	0	0	1	0	1	1	0	1	0	0	1
25.9	0	0	1	0	1	1	0	1	0	1	1
26.0	0	0	1	0	1	1	0	1	0	1	0
26.1	0	0	1	0	1	1	0	1	1	1	0
26.2	0	0	1	0	1	1	0	1	1	0	0

RANGE	PULSE POSITION										
	Altitude in Thousands	D <sub>2</sub>	D <sub>4</sub> and SPI	A <sub>1</sub>	A <sub>2</sub>	A <sub>4</sub>	B <sub>1</sub>	B <sub>2</sub>	B <sub>4</sub>	C <sub>1</sub>	C <sub>2</sub>
26.3	0	0	1	0	1	1	0	0	1	0	0
26.4	0	0	1	0	1	1	0	0	1	1	0
26.5	0	0	1	0	1	1	0	0	0	1	0
26.6	0	0	1	0	1	1	0	0	0	1	1
26.7	0	0	1	0	1	1	0	0	0	0	1
26.8	0	0	1	0	0	1	0	0	0	0	1
26.9	0	0	1	0	0	1	0	0	0	1	1
27.0	0	0	1	0	0	1	0	0	0	1	0
27.1	0	0	1	0	0	1	0	0	1	1	0
27.2	0	0	1	0	0	1	0	0	1	0	0
27.3	0	0	1	0	0	1	0	1	1	0	0
27.4	0	0	1	0	0	1	0	1	1	1	0
27.5	0	0	1	0	0	1	0	1	0	1	0
27.6	0	0	1	0	0	1	0	1	0	1	1
27.7	0	0	1	0	0	1	0	1	0	0	1
27.8	0	0	1	0	0	1	1	1	0	0	1
27.9	0	0	1	0	0	1	1	1	0	1	1
28.0	0	0	1	0	0	1	1	1	0	1	0
28.1	0	0	1	0	0	1	1	1	1	1	0
28.2	0	0	1	0	0	1	1	1	1	0	0
28.3	0	0	1	0	0	1	1	0	1	0	0
28.4	0	0	1	0	0	1	1	0	1	1	0
28.5	0	0	1	0	0	1	1	0	0	1	0
28.6	0	0	1	0	0	1	1	0	0	1	1
28.7	0	0	1	0	0	1	1	0	0	0	1
28.8	0	0	1	0	0	0	1	0	0	0	1
28.9	0	0	1	0	0	0	1	0	0	1	1
29.0	0	0	1	0	0	0	1	0	0	1	0
29.1	0	0	1	0	0	0	1	0	1	1	0
29.2	0	0	1	0	0	0	1	0	1	0	0

RANGE	PULSE POSITION										
Altitude in Thousands	D <sub>2</sub>	D <sub>4</sub> and SPI	A <sub>1</sub>	A <sub>2</sub>	A <sub>4</sub>	B <sub>1</sub>	B <sub>2</sub>	B <sub>4</sub>	C <sub>1</sub>	C <sub>2</sub>	C <sub>4</sub>
29.3	0	0	1	0	0	0	1	1	1	0	0
29.4	0	0	1	0	0	0	1	1	1	1	0
29.5	0	0	1	0	0	0	1	1	0	1	0
29.6	0	0	1	0	0	0	1	1	0	1	1
29.7	0	0	1	0	0	0	1	1	0	0	1
29.8	0	0	1	0	0	0	0	1	0	0	1
29.9	0	0	1	0	0	0	0	1	0	1	1
30.0	0	0	1	0	0	0	0	1	0	1	0
30.1	0	0	1	0	0	0	0	1	1	1	0
30.2	0	0	1	0	0	0	0	1	1	0	0
30.3	0	0	1	0	0	0	0	0	1	0	0
30.4	0	0	1	0	0	0	0	0	1	1	0
30.5	0	0	1	0	0	0	0	0	0	1	0
30.6	0	0	1	0	0	0	0	0	0	1	1
30.7	0	0	1	0	0	0	0	0	0	0	1
30.8	0	1	1	0	0	0	0	0	0	0	1
30.9	0	1	1	0	0	0	0	0	0	1	1
31.0	0	1	1	0	0	0	0	0	0	1	0
31.1	0	1	1	0	0	0	0	0	1	1	0
31.2	0	1	1	0	0	0	0	0	1	0	0
31.3	0	1	1	0	0	0	0	1	1	0	0
31.4	0	1	1	0	0	0	0	1	1	1	0
31.5	0	1	1	0	0	0	0	1	0	1	0
31.6	0	1	1	0	0	0	0	1	0	1	1
31.7	0	1	1	0	0	0	0	1	0	0	1
31.8	0	1	1	0	0	0	1	1	0	0	1
31.9	0	1	1	0	0	0	1	1	0	1	1
32.0	0	1	1	0	0	0	1	1	0	1	0
32.1	0	1	1	0	0	0	1	1	1	1	0
32.2	0	1	1	0	0	0	1	1	1	0	0

RANGE	PULSE POSITION										
	D <sub>2</sub>	D <sub>4</sub> and SPI	A <sub>1</sub>	A <sub>2</sub>	A <sub>4</sub>	B <sub>1</sub>	B <sub>2</sub>	B <sub>4</sub>	C <sub>1</sub>	C <sub>2</sub>	C <sub>4</sub>
32.3	0	1	1	0	0	0	1	0	1	0	0
32.4	0	1	1	0	0	0	1	0	1	1	0
32.5	0	1	1	0	0	0	1	0	0	1	0
32.6	0	1	1	0	0	0	1	0	0	1	1
32.7	0	1	1	0	0	0	1	0	0	0	1
32.8	0	1	1	0	0	1	1	0	0	0	1
32.9	0	1	1	0	0	1	1	0	0	1	1
33.0	0	1	1	0	0	1	1	0	0	1	0
33.1	0	1	1	0	0	1	1	0	1	1	0
33.2	0	1	1	0	0	1	1	0	1	0	0
33.3	0	1	1	0	0	1	1	1	1	0	0
33.4	0	1	1	0	0	1	1	1	1	1	0
33.5	0	1	1	0	0	1	1	1	0	1	0
33.6	0	1	1	0	0	1	1	1	0	1	1
33.7	0	1	1	0	0	1	1	1	0	0	1
33.8	0	1	1	0	0	1	0	1	0	0	1
33.9	0	1	1	0	0	1	0	1	0	1	1
34.0	0	1	1	0	0	1	0	1	0	1	0
34.1	0	1	1	0	0	1	0	1	1	1	0
34.2	0	1	1	0	0	1	0	1	1	0	0
34.3	0	1	1	0	0	1	0	0	1	0	0
34.4	0	1	1	0	0	1	0	0	1	1	0
34.5	0	1	1	0	0	1	0	0	0	1	0
34.6	0	1	1	0	0	1	0	0	0	1	1
34.7	0	1	1	0	0	1	0	0	0	0	1
34.8	0	1	1	0	1	1	0	0	0	0	1
34.9	0	1	1	0	1	1	0	0	0	1	1
35.0	0	1	1	0	1	1	0	0	0	1	0
35.1	0	1	1	0	1	1	0	0	1	1	0
35.2	0	1	1	0	1	1	0	0	1	0	0

RANGE	PULSE POSITION										
Altitude in Thousands	D <sub>2</sub>	D <sub>4</sub> and SPI	A <sub>1</sub>	A <sub>2</sub>	A <sub>4</sub>	B <sub>1</sub>	B <sub>2</sub>	B <sub>4</sub>	C <sub>1</sub>	C <sub>2</sub>	C <sub>4</sub>
35.3	0	1	1	0	1	1	0	1	1	0	0
35.4	0	1	1	0	1	1	0	1	1	1	0
35.5	0	1	1	0	1	1	0	1	0	1	0
35.6	0	1	1	0	1	1	0	1	0	1	1
35.7	0	1	1	0	1	1	0	1	0	0	1
35.8	0	1	1	0	1	1	1	1	0	0	1
35.9	0	1	1	0	1	1	1	1	0	1	1
36.0	0	1	1	0	1	1	1	1	0	1	0
36.1	0	1	1	0	1	1	1	1	1	1	0
36.2	0	1	1	0	1	1	1	1	1	0	0
36.3	0	1	1	0	1	1	1	0	1	0	0
36.4	0	1	1	0	1	1	1	0	1	1	0
36.5	0	1	1	0	1	1	1	0	0	1	0
36.6	0	1	1	0	1	1	1	0	0	1	1
36.7	0	1	1	0	1	1	1	0	0	0	1
36.8	0	1	1	0	1	0	1	0	0	0	1
36.9	0	1	1	0	1	0	1	0	0	1	1
37.0	0	1	1	0	1	0	1	0	0	1	0
37.1	0	1	1	0	1	0	1	0	1	1	0
37.2	0	1	1	0	1	0	1	0	1	0	0
37.3	0	1	1	0	1	0	1	1	1	0	0
37.4	0	1	1	0	1	0	1	1	1	1	0
37.5	0	1	1	0	1	0	1	1	0	1	0
37.6	0	1	1	0	1	0	1	1	0	1	1
37.7	0	1	1	0	1	0	1	1	0	0	1
37.8	0	1	1	0	1	0	0	1	0	0	1
37.9	0	1	1	0	1	0	0	1	0	1	1
38.0	0	1	1	0	1	0	0	1	0	1	0
38.1	0	1	1	0	1	0	0	1	1	1	0
38.2	0	1	1	0	1	0	0	1	1	0	0

RANGE	PULSE POSITION										
Altitude in Thousands	D <sub>2</sub>	D <sub>4</sub> and SPI	A <sub>1</sub>	A <sub>2</sub>	A <sub>4</sub>	B <sub>1</sub>	B <sub>2</sub>	B <sub>4</sub>	C <sub>1</sub>	C <sub>2</sub>	C <sub>4</sub>
38.3	0	1	1	0	1	0	0	0	1	0	0
38.4	0	1	1	0	1	0	0	0	1	1	0
38.5	0	1	1	0	1	0	0	0	0	1	0
38.6	0	1	1	0	1	0	0	0	0	1	1
38.7	0	1	1	0	1	0	0	0	0	0	1
38.8	0	1	1	1	1	0	0	0	0	0	1
38.9	0	1	1	1	1	0	0	0	0	1	1
39.0	0	1	1	1	1	0	0	0	0	1	0
39.1	0	1	1	1	1	0	0	0	1	1	0
39.2	0	1	1	1	1	0	0	0	1	0	0
39.3	0	1	1	1	1	0	0	1	1	0	0
39.4	0	1	1	1	1	0	0	1	1	1	0
39.5	0	1	1	1	1	0	0	1	0	1	0
39.6	0	1	1	1	1	0	0	1	0	1	1
39.7	0	1	1	1	1	0	0	1	0	0	1
39.8	0	1	1	1	1	0	1	1	0	0	1
39.9	0	1	1	1	1	0	1	1	0	1	1
40.0	0	1	1	1	1	0	1	1	0	1	0
40.1	0	1	1	1	1	0	1	1	1	1	0
40.2	0	1	1	1	1	0	1	1	1	0	0
40.3	0	1	1	1	1	0	1	0	1	0	0
40.4	0	1	1	1	1	0	1	0	1	1	0
40.5	0	1	1	1	1	0	1	0	0	1	0
40.6	0	1	1	1	1	0	1	0	0	1	1
40.7	0	1	1	1	1	0	1	0	0	0	1
40.8	0	1	1	1	1	1	1	0	0	0	1
40.9	0	1	1	1	1	1	1	0	0	1	1
41.0	0	1	1	1	1	1	1	0	0	1	0
41.1	0	1	1	1	1	1	1	0	1	1	0
41.2	0	1	1	1	1	1	1	0	1	0	0

RANGE	PULSE POSITION											
	Altitude in Thousands	D <sub>2</sub>	D <sub>4</sub> and SPI	A <sub>1</sub>	A <sub>2</sub>	A <sub>4</sub>	B <sub>1</sub>	B <sub>2</sub>	B <sub>4</sub>	C <sub>1</sub>	C <sub>2</sub>	C <sub>4</sub>
41.3	0	1	1	1	1	1	1	1	1	1	0	0
41.4	0	1	1	1	1	1	1	1	1	1	1	0
41.5	0	1	1	1	1	1	1	1	1	0	1	0
41.6	0	1	1	1	1	1	1	1	1	0	1	1
41.7	0	1	1	1	1	1	1	1	1	0	0	1
41.8	0	1	1	1	1	1	1	0	1	0	0	1
41.9	0	1	1	1	1	1	1	0	1	0	1	1
42.0	0	1	1	1	1	1	1	0	1	0	1	0
42.1	0	1	1	1	1	1	1	0	1	1	1	0
42.2	0	1	1	1	1	1	1	0	1	1	0	0
42.3	0	1	1	1	1	1	1	0	0	1	0	0
42.4	0	1	1	1	1	1	1	0	0	1	1	0
42.5	0	1	1	1	1	1	1	0	0	0	1	0
42.6	0	1	1	1	1	1	1	0	0	0	1	1
42.7	0	1	1	1	1	1	1	0	0	0	0	1
42.8	0	1	1	1	0	1	0	0	0	0	0	1
42.9	0	1	1	1	0	1	0	0	0	0	1	1
43.0	0	1	1	1	0	1	0	0	0	0	1	0
43.1	0	1	1	1	0	1	0	0	0	1	1	0
43.2	0	1	1	1	0	1	0	0	0	1	0	0
43.3	0	1	1	1	0	1	0	1	1	1	0	0
43.4	0	1	1	1	0	1	0	1	1	1	1	0
43.5	0	1	1	1	0	1	0	1	1	0	1	0
43.6	0	1	1	1	0	1	0	1	1	0	1	1
43.7	0	1	1	1	0	1	0	1	1	0	0	1
43.8	0	1	1	1	0	1	1	1	1	0	0	1
43.9	0	1	1	1	0	1	1	1	1	0	1	1
44.0	0	1	1	1	0	1	1	1	1	0	1	0
44.1	0	1	1	1	0	1	1	1	1	1	1	0
44.2	0	1	1	1	0	1	1	1	1	1	0	0

RANGE	PULSE POSITION										
Altitude in Thousands	D <sub>2</sub>	D <sub>4</sub> and SPI	A <sub>1</sub>	A <sub>2</sub>	A <sub>4</sub>	B <sub>1</sub>	B <sub>2</sub>	B <sub>4</sub>	C <sub>1</sub>	C <sub>2</sub>	C <sub>4</sub>
44.3	0	1	1	1	0	1	1	0	1	0	0
44.4	0	1	1	1	0	1	1	0	1	1	0
44.5	0	1	1	1	0	1	1	0	0	1	0
44.6	0	1	1	1	0	1	1	0	0	1	1
44.7	0	1	1	1	0	1	1	0	0	0	1
44.8	0	1	1	1	0	0	1	0	0	0	1
44.9	0	1	1	1	0	0	1	0	0	1	1
45.0	0	1	1	1	0	0	1	0	0	1	0
45.1	0	1	1	1	0	0	1	0	1	1	0
45.2	0	1	1	1	0	0	1	0	1	0	0
45.3	0	1	1	1	0	0	1	1	1	0	0
45.4	0	1	1	1	0	0	1	1	1	1	0
45.5	0	1	1	1	0	0	1	1	0	1	0
45.6	0	1	1	1	0	0	1	1	0	1	1
45.7	0	1	1	1	0	0	1	1	0	0	1
45.8	0	1	1	1	0	0	0	1	0	0	1
45.9	0	1	1	1	0	0	0	1	0	1	1
46.0	0	1	1	1	0	0	0	1	0	1	0
46.1	0	1	1	1	0	0	0	1	1	1	0
46.2	0	1	1	1	0	0	0	1	1	0	0
46.3	0	1	1	1	0	0	0	0	1	0	0
46.4	0	1	1	1	0	0	0	0	1	1	0
46.5	0	1	1	1	0	0	0	0	0	1	0
46.6	0	1	1	1	0	0	0	0	0	1	1
46.7	0	1	1	1	0	0	0	0	0	0	1
46.8	0	1	0	1	0	0	0	0	0	0	1
46.9	0	1	0	1	0	0	0	0	0	1	1
47.0	0	1	0	1	0	0	0	0	0	1	0
47.1	0	1	0	1	0	0	0	0	1	1	0
47.2	0	1	0	1	0	0	0	0	1	0	0



RANGE	PULSE POSITION										
Altitude in Thousands	D <sub>2</sub>	D <sub>4</sub> and SPI	A <sub>1</sub>	A <sub>2</sub>	A <sub>4</sub>	B <sub>1</sub>	B <sub>2</sub>	B <sub>4</sub>	C <sub>1</sub>	C <sub>2</sub>	C <sub>4</sub>
47.3	0	1	0	1	0	0	0	1	1	0	0
47.4	0	1	0	1	0	0	0	1	1	1	0
47.5	0	1	0	1	0	0	0	1	0	1	0
47.6	0	1	0	1	0	0	0	1	0	1	1
47.7	0	1	0	1	0	0	0	1	0	0	1
47.8	0	1	0	1	0	0	1	1	0	0	1
47.9	0	1	0	1	0	0	1	1	0	1	1
48.0	0	1	0	1	0	0	1	1	0	1	0
48.1	0	1	0	1	0	0	1	1	1	1	0
48.2	0	1	0	1	0	0	1	1	1	0	0
48.3	0	1	0	1	0	0	1	0	1	0	0
48.4	0	1	0	1	0	0	1	0	1	1	0
48.5	0	1	0	1	0	0	1	0	0	1	0
48.6	0	1	0	1	0	0	1	0	0	1	1
48.7	0	1	0	1	0	0	1	0	0	0	1
48.8	0	1	0	1	0	1	1	0	0	0	1
48.9	0	1	0	1	0	1	1	0	0	1	1
49.0	0	1	0	1	0	1	1	0	0	1	0
49.1	0	1	0	1	0	1	1	0	1	1	0
49.2	0	1	0	1	0	1	1	0	1	0	0
49.3	0	1	0	1	0	1	1	1	1	0	0
49.4	0	1	0	1	0	1	1	1	1	1	0
49.5	0	1	0	1	0	1	1	1	0	1	0
49.6	0	1	0	1	0	1	1	1	0	1	1
49.7	0	1	0	1	0	1	1	1	0	0	1
49.8	0	1	0	1	0	1	0	1	0	0	1
49.9	0	1	0	1	0	1	0	1	0	1	1
50.0	0	1	0	1	0	1	0	1	0	1	0
50.1	0	1	0	1	0	1	0	1	1	1	0
50.2	0	1	0	1	0	1	0	1	1	0	0

RANGE	PULSE POSITION										
Altitude in Thousands	D <sub>2</sub>	D <sub>4</sub> and SPI	A <sub>1</sub>	A <sub>2</sub>	A <sub>4</sub>	B <sub>1</sub>	B <sub>2</sub>	B <sub>4</sub>	C <sub>1</sub>	C <sub>2</sub>	C <sub>4</sub>
50.3	0	1	0	1	0	1	0	0	1	0	0
50.4	0	1	0	1	0	1	0	0	1	1	0
50.5	0	1	0	1	0	1	0	0	0	1	0
50.6	0	1	0	1	0	1	0	0	0	1	1
50.7	0	1	0	1	0	1	0	0	0	0	1
50.8	0	1	0	1	1	1	0	0	0	0	1
50.9	0	1	0	1	1	1	0	0	0	1	1
51.0	0	1	0	1	1	1	0	0	0	1	0
51.1	0	1	0	1	1	1	0	0	1	1	0
51.2	0	1	0	1	1	1	0	0	1	0	0
51.3	0	1	0	1	1	1	0	1	1	0	0
51.4	0	1	0	1	1	1	0	1	1	1	0
51.5	0	1	0	1	1	1	0	1	0	1	0
51.6	0	1	0	1	1	1	0	1	0	1	1
51.7	0	1	0	1	1	1	0	1	0	0	1
51.8	0	1	0	1	1	1	1	1	0	0	1
51.9	0	1	0	1	1	1	1	1	0	1	1
52.0	0	1	0	1	1	1	1	1	0	1	0
52.1	0	1	0	1	1	1	1	1	1	1	0
52.2	0	1	0	1	1	1	1	1	1	0	0
52.3	0	1	0	1	1	1	1	0	1	0	0
52.4	0	1	0	1	1	1	1	0	1	1	0
52.5	0	1	0	1	1	1	1	0	0	1	0
52.6	0	1	0	1	1	1	1	0	0	1	1
52.7	0	1	0	1	1	1	1	0	0	0	1
52.8	0	1	0	1	1	0	1	0	0	0	1
52.9	0	1	0	1	1	0	1	0	0	1	1
53.0	0	1	0	1	1	0	1	0	0	1	0
53.1	0	1	0	1	1	0	1	0	1	1	0
53.2	0	1	0	1	1	0	1	0	1	0	0

RANGE	PULSE POSITION										
Altitude in Thousands	D <sub>2</sub>	D <sub>4</sub> and SPI	A <sub>1</sub>	A <sub>2</sub>	A <sub>4</sub>	B <sub>1</sub>	B <sub>2</sub>	B <sub>4</sub>	C <sub>1</sub>	C <sub>2</sub>	C <sub>4</sub>
53.3	0	1	0	1	1	0	1	1	1	0	0
53.4	0	1	0	1	1	0	1	1	1	1	0
53.5	0	1	0	1	1	0	1	1	0	1	0
53.6	0	1	0	1	1	0	1	1	0	1	1
53.7	0	1	0	1	1	0	1	1	0	0	1
53.8	0	1	0	1	1	0	0	1	0	0	1
53.9	0	1	0	1	1	0	0	1	0	1	1
54.0	0	1	0	1	1	0	0	1	0	1	0
54.1	0	1	0	1	1	0	0	1	1	1	0
54.2	0	1	0	1	1	0	0	1	1	0	0
54.3	0	1	0	1	1	0	0	0	1	0	0
54.4	0	1	0	1	1	0	0	0	1	1	0
54.5	0	1	0	1	1	0	0	0	0	1	0
54.6	0	1	0	1	1	0	0	0	0	1	1
54.7	0	1	0	1	1	0	0	0	0	0	1
54.8	0	1	0	0	1	0	0	0	0	0	1
54.9	0	1	0	0	1	0	0	0	0	1	1
55.0	0	1	0	0	1	0	0	0	0	1	0
55.1	0	1	0	0	1	0	0	0	1	1	0
55.2	0	1	0	0	1	0	0	0	1	0	0
55.3	0	1	0	0	1	0	0	1	1	0	0
55.4	0	1	0	0	1	0	0	1	1	1	0
55.5	0	1	0	0	1	0	0	1	0	1	0
55.6	0	1	0	0	1	0	0	1	0	1	1
55.7	0	1	0	0	1	0	0	1	0	0	1
55.8	0	1	0	0	1	0	1	1	0	0	1
55.9	0	1	0	0	1	0	1	1	0	1	1
56.0	0	1	0	0	1	0	1	1	0	1	0
56.1	0	1	0	0	1	0	1	1	1	1	0
56.2	0	1	0	0	1	0	1	1	1	0	0

RANGE	PULSE POSITION										
	D <sub>2</sub>	D <sub>4</sub> and SPI	A <sub>1</sub>	A <sub>2</sub>	A <sub>4</sub>	B <sub>1</sub>	B <sub>2</sub>	B <sub>4</sub>	C <sub>1</sub>	C <sub>2</sub>	C <sub>4</sub>
56.3	0	1	0	0	1	0	1	0	1	0	0
56.4	0	1	0	0	1	0	1	0	1	1	0
56.5	0	1	0	0	1	0	1	0	0	1	0
56.6	0	1	0	0	1	0	1	0	0	1	1
56.7	0	1	0	0	1	0	1	0	0	0	1
56.8	0	1	0	0	1	1	1	0	0	0	1
56.9	0	1	0	0	1	1	1	0	0	1	1
57.0	0	1	0	0	1	1	1	0	0	1	0
57.1	0	1	0	0	1	1	1	0	1	1	0
57.2	0	1	0	0	1	1	1	0	1	0	0
57.3	0	1	0	0	1	1	1	1	1	0	0
57.4	0	1	0	0	1	1	1	1	1	1	0
57.5	0	1	0	0	1	1	1	1	0	1	0
57.6	0	1	0	0	1	1	1	1	0	1	1
57.7	0	1	0	0	1	1	1	1	0	0	1
57.8	0	1	0	0	1	1	0	1	0	0	1
57.9	0	1	0	0	1	1	0	1	0	1	1
58.0	0	1	0	0	1	1	0	1	0	1	0
58.1	0	1	0	0	1	1	0	1	1	1	0
58.2	0	1	0	0	1	1	0	1	1	0	0
58.3	0	1	0	0	1	1	0	0	1	0	0
58.4	0	1	0	0	1	1	0	0	1	1	0
58.5	0	1	0	0	1	1	0	0	0	1	0
58.6	0	1	0	0	1	1	0	0	0	1	1
58.7	0	1	0	0	1	1	0	0	0	0	1
58.8	0	1	0	0	0	1	0	0	0	0	1
58.9	0	1	0	0	0	1	0	0	0	1	1
59.0	0	1	0	0	0	1	0	0	0	1	0
59.1	0	1	0	0	0	1	0	0	1	1	0
59.2	0	1	0	0	0	1	0	0	1	0	0

RANGE	PULSE POSITION										
	D <sub>2</sub>	D <sub>4</sub> and SPI	A <sub>1</sub>	A <sub>2</sub>	A <sub>4</sub>	B <sub>1</sub>	B <sub>2</sub>	B <sub>4</sub>	C <sub>1</sub>	C <sub>2</sub>	C <sub>4</sub>
59.3	0	1	0	0	0	1	0	1	1	0	0
59.4	0	1	0	0	0	1	0	1	1	1	0
59.5	0	1	0	0	0	1	0	1	0	1	0
59.6	0	1	0	0	0	1	0	1	0	1	1
59.7	0	1	0	0	0	1	0	1	0	0	1
59.8	0	1	0	0	0	1	1	1	0	0	1
59.9	0	1	0	0	0	1	1	1	0	1	1
60.0	0	1	0	0	0	1	1	1	0	1	0
60.1	0	1	0	0	0	1	1	1	1	1	0
60.2	0	1	0	0	0	1	1	1	1	0	0
60.3	0	1	0	0	0	1	1	0	1	0	0
60.4	0	1	0	0	0	1	1	0	1	1	0
60.5	0	1	0	0	0	1	1	0	0	1	0
60.6	0	1	0	0	0	1	1	0	0	1	1
60.7	0	1	0	0	0	1	1	0	0	0	1
60.8	0	1	0	0	0	0	1	0	0	0	1
60.9	0	1	0	0	0	0	1	0	0	1	1
61.0	0	1	0	0	0	0	1	0	0	1	0
61.1	0	1	0	0	0	0	1	0	1	1	0
61.2	0	1	0	0	0	0	1	0	1	0	0
61.3	0	1	0	0	0	0	1	1	1	0	0
61.4	0	1	0	0	0	0	1	1	1	1	0
61.5	0	1	0	0	0	0	1	1	0	1	0
61.6	0	1	0	0	0	0	1	1	0	1	1
61.7	0	1	0	0	0	0	1	1	0	0	1
61.8	0	1	0	0	0	0	0	1	0	0	1
61.9	0	1	0	0	0	0	0	1	0	1	1
62.0	0	1	0	0	0	0	0	1	0	1	0
62.1	0	1	0	0	0	0	0	1	1	1	0
62.2	0	1	0	0	0	0	0	1	1	0	0

RANGE	PULSE POSITION											
	Altitude in Thousands	D <sub>2</sub>	D <sub>4</sub> and SPI	A <sub>1</sub>	A <sub>2</sub>	A <sub>4</sub>	B <sub>1</sub>	B <sub>2</sub>	B <sub>4</sub>	C <sub>1</sub>	C <sub>2</sub>	C <sub>4</sub>
62.3	0	1	0	0	0	0	0	0	0	1	0	0
62.4	0	1	0	0	0	0	0	0	0	1	1	0
62.5	0	1	0	0	0	0	0	0	0	0	1	0
62.6	0	1	0	0	0	0	0	0	0	0	1	1
62.7	0	1	0	0	0	0	0	0	0	0	0	1
62.8	1	1	0	0	0	0	0	0	0	0	0	1
62.9	1	1	0	0	0	0	0	0	0	0	1	1
63.0	1	1	0	0	0	0	0	0	0	0	1	0
63.1	1	1	0	0	0	0	0	0	0	1	1	0
63.2	1	1	0	0	0	0	0	0	0	1	0	0
63.3	1	1	0	0	0	0	0	0	1	1	0	0
63.4	1	1	0	0	0	0	0	0	1	1	1	0
63.5	1	1	0	0	0	0	0	0	1	0	1	0
63.6	1	1	0	0	0	0	0	0	1	0	1	1
63.7	1	1	0	0	0	0	0	0	1	0	0	1
63.8	1	1	0	0	0	0	0	1	1	0	0	1
63.9	1	1	0	0	0	0	0	1	1	0	1	1
64.0	1	1	0	0	0	0	0	1	1	0	1	0
64.1	1	1	0	0	0	0	0	1	1	1	1	0
64.2	1	1	0	0	0	0	0	1	1	1	0	0
64.3	1	1	0	0	0	0	0	1	0	1	0	0
64.4	1	1	0	0	0	0	0	1	0	1	1	0
64.5	1	1	0	0	0	0	0	1	0	0	1	0
64.6	1	1	0	0	0	0	0	1	0	0	1	1
64.7	1	1	0	0	0	0	0	1	0	0	0	1
64.8	1	1	0	0	0	1	1	0	0	0	0	1
64.9	1	1	0	0	0	1	1	0	0	0	1	1
65.0	1	1	0	0	0	1	1	0	0	0	1	0
65.1	1	1	0	0	0	1	1	0	1	1	1	0
65.2	1	1	0	0	0	1	1	0	1	0	0	0

RANGE	PULSE POSITION											
	Altitude in Thousands	D <sub>2</sub>	D <sub>4</sub> and SPI	A <sub>1</sub>	A <sub>2</sub>	A <sub>4</sub>	B <sub>1</sub>	B <sub>2</sub>	B <sub>4</sub>	C <sub>1</sub>	C <sub>2</sub>	C <sub>4</sub>
65.3	1	1	0	0	0	1	1	1	1	0	0	0
65.4	1	1	0	0	0	1	1	1	1	1	1	0
65.5	1	1	0	0	0	1	1	1	1	0	1	0
65.6	1	1	0	0	0	1	1	1	1	0	1	1
65.7	1	1	0	0	0	1	1	1	1	0	0	1
65.8	1	1	0	0	0	1	0	1	1	0	0	1
65.9	1	1	0	0	0	1	0	1	1	0	1	1
66.0	1	1	0	0	0	1	0	1	1	0	1	0
66.1	1	1	0	0	0	1	0	1	1	1	1	0
66.2	1	1	0	0	0	1	0	1	1	1	0	0
66.3	1	1	0	0	0	1	0	0	1	0	0	0
66.4	1	1	0	0	0	1	0	0	1	1	1	0
66.5	1	1	0	0	0	1	0	0	0	0	1	0
66.6	1	1	0	0	0	1	0	0	0	0	1	1
66.7	1	1	0	0	0	1	0	0	0	0	0	1
66.8	1	1	0	0	1	1	0	0	0	0	0	1
66.9	1	1	0	0	1	1	0	0	0	0	1	1
67.0	1	1	0	0	1	1	0	0	0	0	1	0
67.1	1	1	0	0	1	1	0	0	0	1	1	0
67.2	1	1	0	0	1	1	0	0	0	1	0	0
67.3	1	1	0	0	1	1	0	1	1	1	0	0
67.4	1	1	0	0	1	1	0	1	1	1	1	0
67.5	1	1	0	0	1	1	0	1	0	0	1	0
67.6	1	1	0	0	1	1	0	1	0	0	1	1
67.7	1	1	0	0	1	1	0	1	0	0	0	1
67.8	1	1	0	0	1	1	1	1	1	0	0	1
67.9	1	1	0	0	1	1	1	1	1	0	1	1
68.0	1	1	0	0	1	1	1	1	1	0	1	0
68.1	1	1	0	0	1	1	1	1	1	1	1	0
68.2	1	1	0	0	1	1	1	1	1	1	0	0

RANGE	PULSE POSITION										
Altitude in Thousands	D <sub>2</sub>	D <sub>4</sub> and SPI	A <sub>1</sub>	A <sub>2</sub>	A <sub>4</sub>	B <sub>1</sub>	B <sub>2</sub>	B <sub>4</sub>	C <sub>1</sub>	C <sub>2</sub>	C <sub>4</sub>
68.3	1	1	0	0	1	1	1	0	1	0	0
68.4	1	1	0	0	1	1	1	0	1	1	0
68.5	1	1	0	0	1	1	1	0	0	1	0
68.6	1	1	0	0	1	1	1	0	0	1	1
68.7	1	1	0	0	1	1	1	0	0	0	1
68.8	1	1	0	0	1	0	1	0	0	0	1
68.9	1	1	0	0	1	0	1	0	0	1	1
69.0	1	1	0	0	1	0	1	0	0	1	0
69.1	1	1	0	0	1	0	1	0	1	1	0
69.2	1	1	0	0	1	0	1	0	1	0	0
69.3	1	1	0	0	1	0	1	1	1	0	0
69.4	1	1	0	0	1	0	1	1	1	1	0
69.5	1	1	0	0	1	0	1	1	0	1	0
69.6	1	1	0	0	1	0	1	1	0	1	1
69.7	1	1	0	0	1	0	1	1	0	0	1
69.8	1	1	0	0	1	0	0	1	0	0	1
69.9	1	1	0	0	1	0	0	1	0	1	1
70.0	1	1	0	0	1	0	0	1	0	1	0
70.1	1	1	0	0	1	0	0	1	1	1	0
70.2	1	1	0	0	1	0	0	1	1	0	0
70.3	1	1	0	0	1	0	0	0	1	0	0
70.4	1	1	0	0	1	0	0	0	1	1	0
70.5	1	1	0	0	1	0	0	0	0	1	0
70.6	1	1	0	0	1	0	0	0	0	1	1
70.7	1	1	0	0	1	0	0	0	0	0	1
70.8	1	1	0	1	1	0	0	0	0	0	1
70.9	1	1	0	1	1	0	0	0	0	1	1
71.0	1	1	0	1	1	0	0	0	0	1	0
71.1	1	1	0	1	1	0	0	0	1	1	0
71.2	1	1	0	1	1	0	0	0	1	0	0



RANGE	PULSE POSITION										
	D <sub>2</sub>	D <sub>4</sub> and SPI	A <sub>1</sub>	A <sub>2</sub>	A <sub>4</sub>	B <sub>1</sub>	B <sub>2</sub>	B <sub>4</sub>	C <sub>1</sub>	C <sub>2</sub>	C <sub>4</sub>
71.3	1	1	0	1	1	0	0	1	1	0	0
71.4	1	1	0	1	1	0	0	1	1	1	0
71.5	1	1	0	1	1	0	0	1	0	1	0
71.6	1	1	0	1	1	0	0	1	0	1	1
71.7	1	1	0	1	1	0	0	1	0	0	1
71.8	1	1	0	1	1	0	1	1	0	0	1
71.9	1	1	0	1	1	0	1	1	0	1	1
72.0	1	1	0	1	1	0	1	1	0	1	0
72.1	1	1	0	1	1	0	1	1	1	1	0
72.2	1	1	0	1	1	0	1	1	1	0	0
72.3	1	1	0	1	1	0	1	0	1	0	0
72.4	1	1	0	1	1	0	1	0	1	1	0
72.5	1	1	0	1	1	0	1	0	0	1	0
72.6	1	1	0	1	1	0	1	0	0	1	1
72.7	1	1	0	1	1	0	1	0	0	0	1
72.8	1	1	0	1	1	1	1	0	0	0	1
72.9	1	1	0	1	1	1	1	0	0	1	1
73.0	1	1	0	1	1	1	1	0	0	1	0
73.1	1	1	0	1	1	1	1	0	1	1	0
73.2	1	1	0	1	1	1	1	0	1	0	0
73.3	1	1	0	1	1	1	1	1	1	0	0
73.4	1	1	0	1	1	1	1	1	1	1	0
73.5	1	1	0	1	1	1	1	1	0	1	0
73.6	1	1	0	1	1	1	1	1	0	1	1
73.7	1	1	0	1	1	1	1	1	0	0	1
73.8	1	1	0	1	1	1	0	1	0	0	1
73.9	1	1	0	1	1	1	0	1	0	1	1
74.0	1	1	0	1	1	1	0	1	0	1	0
74.1	1	1	0	1	1	1	0	1	1	1	0
74.2	1	1	0	1	1	1	0	1	1	0	0

RANGE	PULSE POSITION										
	Altitude in Thousands	D <sub>2</sub>	D <sub>4</sub> and SPI	A <sub>1</sub>	A <sub>2</sub>	A <sub>4</sub>	B <sub>1</sub>	B <sub>2</sub>	B <sub>4</sub>	C <sub>1</sub>	C <sub>2</sub>
74.3	1	1	0	1	1	1	0	0	1	0	0
74.4	1	1	0	1	1	1	0	0	1	1	0
74.5	1	1	0	1	1	1	0	0	0	1	0
74.6	1	1	0	1	1	1	0	0	0	1	1
74.7	1	1	0	1	1	1	0	0	0	0	1
74.8	1	1	0	1	0	1	0	0	0	0	1
74.9	1	1	0	1	0	1	0	0	0	1	1
75.0	1	1	0	1	0	1	0	0	0	1	0
75.1	1	1	0	1	0	1	0	0	1	1	0
75.2	1	1	0	1	0	1	0	0	1	0	0
75.3	1	1	0	1	0	1	0	1	1	0	0
75.4	1	1	0	1	0	1	0	1	1	1	0
75.5	1	1	0	1	0	1	0	1	0	1	0
75.6	1	1	0	1	0	1	0	1	0	1	1
75.7	1	1	0	1	0	1	0	1	0	0	1
75.8	1	1	0	1	0	1	1	1	0	0	1
75.9	1	1	0	1	0	1	1	1	0	1	1
76.0	1	1	0	1	0	1	1	1	0	1	0
76.1	1	1	0	1	0	1	1	1	1	1	0
76.2	1	1	0	1	0	1	1	1	1	0	0
76.3	1	1	0	1	0	1	1	0	1	0	0
76.4	1	1	0	1	0	1	1	0	1	1	0
76.5	1	1	0	1	0	1	1	0	0	1	0
76.6	1	1	0	1	0	1	1	0	0	1	1
76.7	1	1	0	1	0	1	1	0	0	0	1
76.8	1	1	0	1	0	0	1	0	0	0	1
76.9	1	1	0	1	0	0	1	0	0	1	1
77.0	1	1	0	1	0	0	1	0	0	1	0
77.1	1	1	0	1	0	0	1	0	1	1	0
77.2	1	1	0	1	0	0	1	0	1	0	0

RANGE	PULSE POSITION										
Altitude in Thousands	D <sub>2</sub>	D <sub>4</sub> and SPI	A <sub>1</sub>	A <sub>2</sub>	A <sub>4</sub>	B <sub>1</sub>	B <sub>2</sub>	B <sub>4</sub>	C <sub>1</sub>	C <sub>2</sub>	C <sub>4</sub>
77.3	1	1	0	1	0	0	1	1	1	0	0
77.4	1	1	0	1	0	0	1	1	1	1	0
77.5	1	1	0	1	0	0	1	1	0	1	0
77.6	1	1	0	1	0	0	1	1	0	1	1
77.7	1	1	0	1	0	0	1	1	0	0	1
77.8	1	1	0	1	0	0	0	1	0	0	1
77.9	1	1	0	1	0	0	0	1	0	1	1
78.0	1	1	0	1	0	0	0	1	0	1	0
78.1	1	1	0	1	0	0	0	1	1	1	0
78.2	1	1	0	1	0	0	0	1	1	0	0
78.3	1	1	0	1	0	0	0	0	1	0	0
78.4	1	1	0	1	0	0	0	0	1	1	0
78.5	1	1	0	1	0	0	0	0	0	1	0
78.6	1	1	0	1	0	0	0	0	0	1	1
78.7	1	1	0	1	0	0	0	0	0	0	1
78.8	1	1	1	1	0	0	0	0	0	0	1
78.9	1	1	1	1	0	0	0	0	0	1	1
79.0	1	1	1	1	0	0	0	0	0	1	0
79.1	1	1	1	1	0	0	0	0	1	1	0
79.2	1	1	1	1	0	0	0	0	1	0	0
79.3	1	1	1	1	0	0	0	1	1	0	0
79.4	1	1	1	1	0	0	0	1	1	1	0
79.5	1	1	1	1	0	0	0	1	0	1	0
79.6	1	1	1	1	0	0	0	1	0	1	1
79.7	1	1	1	1	0	0	0	1	0	0	1
79.8	1	1	1	1	0	0	1	1	0	0	1
79.9	1	1	1	1	0	0	1	1	0	1	1
80.0	1	1	1	1	0	0	1	1	0	1	0
80.1	1	1	1	1	0	0	1	1	1	1	0
80.2	1	1	1	1	0	0	1	1	1	0	0

RANGE	PULSE POSITION										
	Altitude in Thousands	D <sub>2</sub>	D <sub>4</sub> and SPI	A <sub>1</sub>	A <sub>2</sub>	A <sub>4</sub>	B <sub>1</sub>	B <sub>2</sub>	B <sub>4</sub>	C <sub>1</sub>	C <sub>2</sub>
80.3	1	1	1	1	0	0	1	0	1	0	0
80.4	1	1	1	1	0	0	1	0	1	1	0
80.5	1	1	1	1	0	0	1	0	0	1	0
80.6	1	1	1	1	0	0	1	0	0	1	1
80.7	1	1	1	1	0	0	1	0	0	0	1
80.8	1	1	1	1	0	1	1	0	0	0	1
80.9	1	1	1	1	0	1	1	0	0	1	1
81.0	1	1	1	1	0	1	1	0	0	1	0
81.1	1	1	1	1	0	1	1	0	1	1	0
81.2	1	1	1	1	0	1	1	0	1	0	0
81.3	1	1	1	1	0	1	1	1	1	0	0
81.4	1	1	1	1	0	1	1	1	1	1	0
81.5	1	1	1	1	0	1	1	1	0	1	0
81.6	1	1	1	1	0	1	1	1	0	1	1
81.7	1	1	1	1	0	1	1	1	0	0	1
81.8	1	1	1	1	0	1	0	1	0	0	1
81.9	1	1	1	1	0	1	0	1	0	1	1
82.0	1	1	1	1	0	1	0	1	0	1	0
82.1	1	1	1	1	0	1	0	1	1	1	0
82.2	1	1	1	1	0	1	0	1	1	0	0
82.3	1	1	1	1	0	1	0	0	1	0	0
82.4	1	1	1	1	0	1	0	0	1	1	0
82.5	1	1	1	1	0	1	0	0	0	1	0
82.6	1	1	1	1	0	1	0	0	0	1	1
82.7	1	1	1	1	0	1	0	0	0	0	1
82.8	1	1	1	1	1	1	0	0	0	0	1
82.9	1	1	1	1	1	1	0	0	0	1	1
83.0	1	1	1	1	1	1	0	0	0	1	0
83.1	1	1	1	1	1	1	0	0	1	1	0
83.2	1	1	1	1	1	1	0	0	1	0	0

RANGE	PULSE POSITION										
	Altitude in Thousands	D <sub>2</sub>	D <sub>4</sub> and SPI	A <sub>1</sub>	A <sub>2</sub>	A <sub>4</sub>	B <sub>1</sub>	B <sub>2</sub>	B <sub>4</sub>	C <sub>1</sub>	C <sub>2</sub>
83.3	1	1	1	1	1	1	0	1	1	0	0
83.4	1	1	1	1	1	1	0	1	1	1	0
83.5	1	1	1	1	1	1	0	1	0	1	0
83.6	1	1	1	1	1	1	0	1	0	1	1
83.7	1	1	1	1	1	1	0	1	0	0	1
83.8	1	1	1	1	1	1	1	1	0	0	1
83.9	1	1	1	1	1	1	1	1	0	1	1
84.0	1	1	1	1	1	1	1	1	0	1	0
84.1	1	1	1	1	1	1	1	1	1	1	0
84.2	1	1	1	1	1	1	1	1	1	0	0
84.3	1	1	1	1	1	1	1	0	1	0	0
84.4	1	1	1	1	1	1	1	0	1	1	0
84.5	1	1	1	1	1	1	1	0	0	1	0
84.6	1	1	1	1	1	1	1	0	0	1	1
84.7	1	1	1	1	1	1	1	0	0	0	1
84.8	1	1	1	1	1	0	1	0	0	0	1
84.9	1	1	1	1	1	0	1	0	0	1	1
85.0	1	1	1	1	1	0	1	0	0	1	0
85.1	1	1	1	1	1	0	1	0	1	1	0
85.2	1	1	1	1	1	0	1	0	1	0	0
85.3	1	1	1	1	1	0	1	1	1	0	0
85.4	1	1	1	1	1	0	1	1	1	1	0
85.5	1	1	1	1	1	0	1	1	0	1	0
85.6	1	1	1	1	1	0	1	1	0	1	1
85.7	1	1	1	1	1	0	1	1	0	0	1
85.8	1	1	1	1	1	0	0	1	0	0	1
85.9	1	1	1	1	1	0	0	1	0	1	1
86.0	1	1	1	1	1	0	0	1	0	1	0
86.1	1	1	1	1	1	0	0	1	1	1	0
86.2	1	1	1	1	1	0	0	1	1	0	0

RANGE	PULSE POSITION										
Altitude in Thousands	D <sub>2</sub>	D <sub>4</sub> and SPI	A <sub>1</sub>	A <sub>2</sub>	A <sub>4</sub>	B <sub>1</sub>	B <sub>2</sub>	B <sub>4</sub>	C <sub>1</sub>	C <sub>2</sub>	C <sub>4</sub>
86.3	1	1	1	1	1	0	0	0	1	0	0
86.4	1	1	1	1	1	0	0	0	1	1	0
86.5	1	1	1	1	1	0	0	0	0	1	0
86.6	1	1	1	1	1	0	0	0	0	1	1
86.7	1	1	1	1	1	0	0	0	0	0	1
86.8	1	1	1	0	1	0	0	0	0	0	1
86.9	1	1	1	0	1	0	0	0	0	1	1
87.0	1	1	1	0	1	0	0	0	0	1	0
87.1	1	1	1	0	1	0	0	0	1	1	0
87.2	1	1	1	0	1	0	0	0	1	0	0
87.3	1	1	1	0	1	0	0	1	1	0	0
87.4	1	1	1	0	1	0	0	1	1	1	0
87.5	1	1	1	0	1	0	0	1	0	1	0
87.6	1	1	1	0	1	0	0	1	0	1	1
87.7	1	1	1	0	1	0	0	1	0	0	1
87.8	1	1	1	0	1	0	1	1	0	0	1
87.9	1	1	1	0	1	0	1	1	0	1	1
88.0	1	1	1	0	1	0	1	1	0	1	0
88.1	1	1	1	0	1	0	1	1	1	1	0
88.2	1	1	1	0	1	0	1	1	1	0	0
88.3	1	1	1	0	1	0	1	0	1	0	0
88.4	1	1	1	0	1	0	1	0	1	1	0
88.5	1	1	1	0	1	0	1	0	0	1	0
88.6	1	1	1	0	1	0	1	0	0	1	1
88.7	1	1	1	0	1	0	1	0	0	0	1
88.8	1	1	1	0	1	1	1	0	0	0	1
88.9	1	1	1	0	1	1	1	0	0	1	1
89.0	1	1	1	0	1	1	1	0	0	1	0
89.1	1	1	1	0	1	1	1	0	1	1	0
89.2	1	1	1	0	1	1	1	0	1	0	0

RANGE	PULSE POSITION											
	Altitude in Thousands	D <sub>2</sub>	D <sub>4</sub> and SPI	A <sub>1</sub>	A <sub>2</sub>	A <sub>4</sub>	B <sub>1</sub>	B <sub>2</sub>	B <sub>4</sub>	C <sub>1</sub>	C <sub>2</sub>	C <sub>4</sub>
89.3	1	1	1	0	1	1	1	1	1	1	0	0
89.4	1	1	1	0	1	1	1	1	1	1	1	0
89.5	1	1	1	0	1	1	1	1	1	0	1	0
89.6	1	1	1	0	1	1	1	1	1	0	1	1
89.7	1	1	1	0	1	1	1	1	1	0	0	1
89.8	1	1	1	0	1	1	0	1	1	0	0	1
89.9	1	1	1	0	1	1	0	1	1	0	1	1
90.0	1	1	1	0	1	1	0	1	1	0	1	0
90.1	1	1	1	0	1	1	0	1	1	1	1	0
90.2	1	1	1	0	1	1	0	1	1	1	0	0
90.3	1	1	1	0	1	1	0	0	1	1	0	0
90.4	1	1	1	0	1	1	0	0	1	1	1	0
90.5	1	1	1	0	1	1	0	0	1	0	1	0
90.6	1	1	1	0	1	1	0	0	1	0	1	1
90.7	1	1	1	0	1	1	0	0	1	0	0	1
90.8	1	1	1	0	0	1	0	0	1	0	0	1
90.9	1	1	1	0	0	1	0	0	1	0	1	1
91.0	1	1	1	0	0	1	0	0	1	0	1	0
91.1	1	1	1	0	0	1	0	0	1	1	1	0
91.2	1	1	1	0	0	1	0	0	1	1	0	0
91.3	1	1	1	0	0	1	0	1	1	1	0	0
91.4	1	1	1	0	0	1	0	1	1	1	1	0
91.5	1	1	1	0	0	1	0	1	1	0	1	0
91.6	1	1	1	0	0	1	0	1	1	0	1	1
91.7	1	1	1	0	0	1	0	1	1	0	0	1
91.8	1	1	1	0	0	1	1	1	1	0	0	1
91.9	1	1	1	0	0	1	1	1	1	0	1	1
92.0	1	1	1	0	0	1	1	1	1	0	1	0
92.1	1	1	1	0	0	1	1	1	1	1	1	0
92.2	1	1	1	0	0	1	1	1	1	1	0	0

RANGE	PULSE POSITION										
	D <sub>2</sub>	D <sub>4</sub> and SPI	A <sub>1</sub>	A <sub>2</sub>	A <sub>4</sub>	B <sub>1</sub>	B <sub>2</sub>	B <sub>4</sub>	C <sub>1</sub>	C <sub>2</sub>	C <sub>4</sub>
92.3	1	1	1	0	0	1	1	0	1	0	0
92.4	1	1	1	0	0	1	1	0	1	1	0
92.5	1	1	1	0	0	1	1	0	0	1	0
92.6	1	1	1	0	0	1	1	0	0	1	1
92.7	1	1	1	0	0	1	1	0	0	0	1
92.8	1	1	1	0	0	0	1	0	0	0	1
92.9	1	1	1	0	0	0	1	0	0	1	1
93.0	1	1	1	0	0	0	1	0	0	1	0
93.1	1	1	1	0	0	0	1	0	1	1	0
93.2	1	1	1	0	0	0	1	0	1	0	0
93.3	1	1	1	0	0	0	1	1	1	0	0
93.4	1	1	1	0	0	0	1	1	1	1	0
93.5	1	1	1	0	0	0	1	1	0	1	0
93.6	1	1	1	0	0	0	1	1	0	1	1
93.7	1	1	1	0	0	0	1	1	0	0	1
93.8	1	1	1	0	0	0	0	1	0	0	1
93.9	1	1	1	0	0	0	0	1	0	1	1
94.0	1	1	1	0	0	0	0	1	0	1	0
94.1	1	1	1	0	0	0	0	1	1	1	0
94.2	1	1	1	0	0	0	0	1	1	0	0
94.3	1	1	1	0	0	0	0	0	1	0	0
94.4	1	1	1	0	0	0	0	0	1	1	0
94.5	1	1	1	0	0	0	0	0	0	1	0
94.6	1	1	1	0	0	0	0	0	0	1	1
94.7	1	1	1	0	0	0	0	0	0	0	1
94.8	1	0	1	0	0	0	0	0	0	0	1
94.9	1	0	1	0	0	0	0	0	0	1	1
95.0	1	0	1	0	0	0	0	0	0	1	0
95.1	1	0	1	0	0	0	0	0	1	1	0
95.2	1	0	1	0	0	0	0	0	1	0	0



RANGE	PULSE POSITION										
Altitude in Thousands	D <sub>2</sub>	D <sub>4</sub> and SPI	A <sub>1</sub>	A <sub>2</sub>	A <sub>4</sub>	B <sub>1</sub>	B <sub>2</sub>	B <sub>4</sub>	C <sub>1</sub>	C <sub>2</sub>	C <sub>4</sub>
95.3	1	0	1	0	0	0	0	1	1	0	0
95.4	1	0	1	0	0	0	0	1	1	1	0
95.5	1	0	1	0	0	0	0	1	0	1	0
95.6	1	0	1	0	0	0	0	1	0	1	1
95.7	1	0	1	0	0	0	0	1	0	0	1
95.8	1	0	1	0	0	0	1	1	0	0	1
95.9	1	0	1	0	0	0	1	1	0	1	1
96.0	1	0	1	0	0	0	1	1	0	1	0
96.1	1	0	1	0	0	0	1	1	1	1	0
96.2	1	0	1	0	0	0	1	1	1	0	0
96.3	1	0	1	0	0	0	1	0	1	0	0
96.4	1	0	1	0	0	0	1	0	1	1	0
96.5	1	0	1	0	0	0	1	0	0	1	0
96.6	1	0	1	0	0	0	1	0	0	1	1
96.7	1	0	1	0	0	0	1	0	0	0	1
96.8	1	0	1	0	0	1	1	0	0	0	1
96.9	1	0	1	0	0	1	1	0	0	1	1
97.0	1	0	1	0	0	1	1	0	0	1	0
97.1	1	0	1	0	0	1	1	0	1	1	0
97.2	1	0	1	0	0	1	1	0	1	0	0
97.3	1	0	1	0	0	1	1	1	1	0	0
97.4	1	0	1	0	0	1	1	1	1	1	0
97.5	1	0	1	0	0	1	1	1	0	1	0
97.6	1	0	1	0	0	1	1	1	0	1	1
97.7	1	0	1	0	0	1	1	1	0	0	1
97.8	1	0	1	0	0	1	0	1	0	0	1
97.9	1	0	1	0	0	1	0	1	0	1	1
98.0	1	0	1	0	0	1	0	1	0	1	0
98.1	1	0	1	0	0	1	0	1	1	1	0
98.2	1	0	1	0	0	1	0	1	1	0	0

RANGE	PULSE POSITION										
Altitude in Thousands	D <sub>2</sub>	D <sub>4</sub> and SPI	A <sub>1</sub>	A <sub>2</sub>	A <sub>4</sub>	B <sub>1</sub>	B <sub>2</sub>	B <sub>4</sub>	C <sub>1</sub>	C <sub>2</sub>	C <sub>4</sub>
98.3	1	0	1	0	0	1	0	0	1	0	0
98.4	1	0	1	0	0	1	0	0	1	1	0
98.5	1	0	1	0	0	1	0	0	0	1	0
98.6	1	0	1	0	0	1	0	0	0	1	1
98.7	1	0	1	0	0	1	0	0	0	0	1
98.8	1	0	1	0	1	1	0	0	0	0	1
98.9	1	0	1	0	1	1	0	0	0	1	1
99.0	1	0	1	0	1	1	0	0	0	1	0
99.1	1	0	1	0	1	1	0	0	1	1	0
99.2	1	0	1	0	1	1	0	0	1	0	0
99.3	1	0	1	0	1	1	0	1	1	0	0
99.4	1	0	1	0	1	1	0	1	1	1	0
99.5	1	0	1	0	1	1	0	1	0	1	0
99.6	1	0	1	0	1	1	0	1	0	1	1
99.7	1	0	1	0	1	1	0	1	0	0	1
99.8	1	0	1	0	1	1	1	1	0	0	1
99.9	1	0	1	0	1	1	1	1	0	1	1
100.0	1	0	1	0	1	1	1	1	0	1	0
100.1	1	0	1	0	1	1	1	1	1	1	0
100.2	1	0	1	0	1	1	1	1	1	0	0
100.3	1	0	1	0	1	1	1	0	1	0	0
100.4	1	0	1	0	1	1	1	0	1	1	0
100.5	1	0	1	0	1	1	1	0	0	1	0
100.6	1	0	1	0	1	1	1	0	0	1	1
100.7	1	0	1	0	1	1	1	0	0	0	1
100.8	1	0	1	0	1	0	1	0	0	0	1
100.9	1	0	1	0	1	0	1	0	0	1	1
101.0	1	0	1	0	1	0	1	0	0	1	0
101.1	1	0	1	0	1	0	1	0	1	1	0
101.2	1	0	1	0	1	0	1	0	1	0	0

RANGE	PULSE POSITION										
Altitude in Thousands	D <sub>2</sub>	D <sub>4</sub> and SPI	A <sub>1</sub>	A <sub>2</sub>	A <sub>4</sub>	B <sub>1</sub>	B <sub>2</sub>	B <sub>4</sub>	C <sub>1</sub>	C <sub>2</sub>	C <sub>4</sub>
101.3	1	0	1	0	1	0	1	1	1	0	0
101.4	1	0	1	0	1	0	1	1	1	1	0
101.5	1	0	1	0	1	0	1	1	0	1	0
101.6	1	0	1	0	1	0	1	1	0	1	1
101.7	1	0	1	0	1	0	1	1	0	0	1
101.8	1	0	1	0	1	0	0	1	0	0	1
101.9	1	0	1	0	1	0	0	1	0	1	1
102.0	1	0	1	0	1	0	0	1	0	1	0
102.1	1	0	1	0	1	0	0	1	1	1	0
102.2	1	0	1	0	1	0	0	1	1	0	0
102.3	1	0	1	0	1	0	0	0	1	0	0
102.4	1	0	1	0	1	0	0	0	1	1	0
102.5	1	0	1	0	1	0	0	0	0	1	0
102.6	1	0	1	0	1	0	0	0	0	1	1
102.7	1	0	1	0	1	0	0	0	0	0	1
102.8	1	0	1	1	1	0	0	0	0	0	1
102.9	1	0	1	1	1	0	0	0	0	1	1
103.0	1	0	1	1	1	0	0	0	0	1	0
103.1	1	0	1	1	1	0	0	0	1	1	0
103.2	1	0	1	1	1	0	0	0	1	0	0
103.3	1	0	1	1	1	0	0	1	1	0	0
103.4	1	0	1	1	1	0	0	1	1	1	0
103.5	1	0	1	1	1	0	0	1	0	1	0
103.6	1	0	1	1	1	0	0	1	0	1	1
103.7	1	0	1	1	1	0	0	1	0	0	1
103.8	1	0	1	1	1	0	1	1	0	0	1
103.9	1	0	1	1	1	0	1	1	0	1	1
104.0	1	0	1	1	1	0	1	1	0	1	0
104.1	1	0	1	1	1	0	1	1	1	1	0
104.2	1	0	1	1	1	0	1	1	1	0	0

RANGE	PULSE POSITION										
Altitude in Thousands	D <sub>2</sub>	D <sub>4</sub> and SPI	A <sub>1</sub>	A <sub>2</sub>	A <sub>4</sub>	B <sub>1</sub>	B <sub>2</sub>	B <sub>4</sub>	C <sub>1</sub>	C <sub>2</sub>	C <sub>4</sub>
104.3	1	0	1	1	1	0	1	0	1	0	0
104.4	1	0	1	1	1	0	1	0	1	1	0
104.5	1	0	1	1	1	0	1	0	0	1	0
104.6	1	0	1	1	1	0	1	0	0	1	1
104.7	1	0	1	1	1	0	1	0	0	0	1
104.8	1	0	1	1	1	1	1	0	0	0	1
104.9	1	0	1	1	1	1	1	0	0	1	1
105.0	1	0	1	1	1	1	1	0	0	1	0
105.1	1	0	1	1	1	1	1	0	1	1	0
105.2	1	0	1	1	1	1	1	0	1	0	0
105.3	1	0	1	1	1	1	1	1	1	0	0
105.4	1	0	1	1	1	1	1	1	1	1	0
105.5	1	0	1	1	1	1	1	1	0	1	0
105.6	1	0	1	1	1	1	1	1	0	1	1
105.7	1	0	1	1	1	1	1	1	0	0	1
105.8	1	0	1	1	1	1	0	1	0	0	1
105.9	1	0	1	1	1	1	0	1	0	1	1
106.0	1	0	1	1	1	1	0	1	0	1	0
106.1	1	0	1	1	1	1	0	1	1	1	0
106.2	1	0	1	1	1	1	0	1	1	0	0
106.3	1	0	1	1	1	1	0	0	1	0	0
106.4	1	0	1	1	1	1	0	0	1	1	0
106.5	1	0	1	1	1	1	0	0	0	1	0
106.6	1	0	1	1	1	1	0	0	0	1	1
106.7	1	0	1	1	1	1	0	0	0	0	1
106.8	1	0	1	1	0	1	0	0	0	0	1
106.9	1	0	1	1	0	1	0	0	0	1	1
107.0	1	0	1	1	0	1	0	0	0	1	0
107.1	1	0	1	1	0	1	0	0	1	1	0
107.2	1	0	1	1	0	1	0	0	1	0	0

RANGE	PULSE POSITION										
Altitude in Thousands	D <sub>2</sub>	D <sub>4</sub> and SPI	A <sub>1</sub>	A <sub>2</sub>	A <sub>4</sub>	B <sub>1</sub>	B <sub>2</sub>	B <sub>4</sub>	C <sub>1</sub>	C <sub>2</sub>	C <sub>4</sub>
107.3	1	0	1	1	0	1	0	1	1	0	0
107.4	1	0	1	1	0	1	0	1	1	1	0
107.5	1	0	1	1	0	1	0	1	0	1	0
107.6	1	0	1	1	0	1	0	1	0	1	1
107.7	1	0	1	1	0	1	0	1	0	0	1
107.8	1	0	1	1	0	1	1	1	0	0	1
107.9	1	0	1	1	0	1	1	1	0	1	1
108.0	1	0	1	1	0	1	1	1	0	1	0
108.1	1	0	1	1	0	1	1	1	1	1	0
108.2	1	0	1	1	0	1	1	1	1	0	0
108.3	1	0	1	1	0	1	1	0	1	0	0
108.4	1	0	1	1	0	1	1	0	1	1	0
108.5	1	0	1	1	0	1	1	0	0	1	0
108.6	1	0	1	1	0	1	1	0	0	1	1
108.7	1	0	1	1	0	1	1	0	0	0	1
108.8	1	0	1	1	0	0	1	0	0	0	1
108.9	1	0	1	1	0	0	1	0	0	1	1
109.0	1	0	1	1	0	0	1	0	0	1	0
109.1	1	0	1	1	0	0	1	0	1	1	0
109.2	1	0	1	1	0	0	1	0	1	0	0
109.3	1	0	1	1	0	0	1	1	1	0	0
109.4	1	0	1	1	0	0	1	1	1	1	0
109.5	1	0	1	1	0	0	1	1	0	1	0
109.6	1	0	1	1	0	0	1	1	0	1	1
109.7	1	0	1	1	0	0	1	1	0	0	1
109.8	1	0	1	1	0	0	0	1	0	0	1
109.9	1	0	1	1	0	0	0	1	0	1	1
110.0	1	0	1	1	0	0	0	1	0	1	0
110.1	1	0	1	1	0	0	0	1	1	1	0
110.2	1	0	1	1	0	0	0	1	1	0	0

RANGE	PULSE POSITION											
	Altitude in Thousands	D <sub>2</sub>	D <sub>4</sub> and SPI	A <sub>1</sub>	A <sub>2</sub>	A <sub>4</sub>	B <sub>1</sub>	B <sub>2</sub>	B <sub>4</sub>	C <sub>1</sub>	C <sub>2</sub>	C <sub>4</sub>
110.3	1	0	1	1	0	0	0	0	0	1	0	0
110.4	1	0	1	1	0	0	0	0	0	1	1	0
110.5	1	0	1	1	0	0	0	0	0	0	1	0
110.6	1	0	1	1	0	0	0	0	0	0	1	1
110.7	1	0	1	1	0	0	0	0	0	0	0	1
110.8	1	0	0	1	0	0	0	0	0	0	0	1
110.9	1	0	0	1	0	0	0	0	0	0	1	1
111.0	1	0	0	1	0	0	0	0	0	0	1	0
111.1	1	0	0	1	0	0	0	0	0	1	1	0
111.2	1	0	0	1	0	0	0	0	0	1	0	0
111.3	1	0	0	1	0	0	0	0	1	1	0	0
111.4	1	0	0	1	0	0	0	0	1	1	1	0
111.5	1	0	0	1	0	0	0	0	1	0	1	0
111.6	1	0	0	1	0	0	0	0	1	0	1	1
111.7	1	0	0	1	0	0	0	0	1	0	0	1
111.8	1	0	0	1	0	0	0	1	1	0	0	1
111.9	1	0	0	1	0	0	0	1	1	0	1	1
112.0	1	0	0	1	0	0	0	1	1	0	1	0
112.1	1	0	0	1	0	0	0	1	1	1	1	0
112.2	1	0	0	1	0	0	0	1	1	1	0	0
112.3	1	0	0	1	0	0	0	1	0	1	0	0
112.4	1	0	0	1	0	0	0	1	0	1	1	0
112.5	1	0	0	1	0	0	0	1	0	0	1	0
112.6	1	0	0	1	0	0	0	1	0	0	1	1
112.7	1	0	0	1	0	0	0	1	0	0	0	1
112.8	1	0	0	1	0	1	1	0	0	0	0	1
112.9	1	0	0	1	0	1	1	0	0	0	1	1
113.0	1	0	0	1	0	1	1	0	0	0	1	0
113.1	1	0	0	1	0	1	1	0	1	1	1	0
113.2	1	0	0	1	0	1	1	0	1	0	0	0

RANGE	PULSE POSITION										
Altitude in Thousands	D <sub>2</sub>	D <sub>4</sub> and SPI	A <sub>1</sub>	A <sub>2</sub>	A <sub>4</sub>	B <sub>1</sub>	B <sub>2</sub>	B <sub>4</sub>	C <sub>1</sub>	C <sub>2</sub>	C <sub>4</sub>
113.3	1	0	0	1	0	1	1	1	1	0	0
113.4	1	0	0	1	0	1	1	1	1	1	0
113.5	1	0	0	1	0	1	1	1	0	1	0
113.6	1	0	0	1	0	1	1	1	0	1	1
113.7	1	0	0	1	0	1	1	1	0	0	1
113.8	1	0	0	1	0	1	0	1	0	0	1
113.9	1	0	0	1	0	1	0	1	0	1	1
114.0	1	0	0	1	0	1	0	1	0	1	0
114.1	1	0	0	1	0	1	0	1	1	1	0
114.2	1	0	0	1	0	1	0	1	1	0	0
114.3	1	0	0	1	0	1	0	0	1	0	0
114.4	1	0	0	1	0	1	0	0	1	1	0
114.5	1	0	0	1	0	1	0	0	0	1	0
114.6	1	0	0	1	0	1	0	0	0	1	1
114.7	1	0	0	1	0	1	0	0	0	0	1
114.8	1	0	0	1	1	1	0	0	0	0	1
114.9	1	0	0	1	1	1	0	0	0	1	1
115.0	1	0	0	1	1	1	0	0	0	1	0
115.1	1	0	0	1	1	1	0	0	1	1	0
115.2	1	0	0	1	1	1	0	0	1	0	0
115.3	1	0	0	1	1	1	0	1	1	0	0
115.4	1	0	0	1	1	1	0	1	1	1	0
115.5	1	0	0	1	1	1	0	1	0	1	0
115.6	1	0	0	1	1	1	0	1	0	1	1
115.7	1	0	0	1	1	1	0	1	0	0	1
115.8	1	0	0	1	1	1	1	1	0	0	1
115.9	1	0	0	1	1	1	1	1	0	1	1
116.0	1	0	0	1	1	1	1	1	0	1	0
116.1	1	0	0	1	1	1	1	1	1	1	0
116.2	1	0	0	1	1	1	1	1	1	0	0

RANGE	PULSE POSITION										
Altitude in Thousands	D <sub>2</sub>	D <sub>4</sub> and SPI	A <sub>1</sub>	A <sub>2</sub>	A <sub>4</sub>	B <sub>1</sub>	B <sub>2</sub>	B <sub>4</sub>	C <sub>1</sub>	C <sub>2</sub>	C <sub>4</sub>
116.3	1	0	0	1	1	1	1	0	1	0	0
116.4	1	0	0	1	1	1	1	0	1	1	0
116.5	1	0	0	1	1	1	1	0	0	1	0
116.6	1	0	0	1	1	1	1	0	0	1	1
116.7	1	0	0	1	1	1	1	0	0	0	1
116.8	1	0	0	1	1	0	1	0	0	0	1
116.9	1	0	0	1	1	0	1	0	0	1	1
117.0	1	0	0	1	1	0	1	0	0	1	0
117.1	1	0	0	1	1	0	1	0	1	1	0
117.2	1	0	0	1	1	0	1	0	1	0	0
117.3	1	0	0	1	1	0	1	1	1	0	0
117.4	1	0	0	1	1	0	1	1	1	1	0
117.5	1	0	0	1	1	0	1	1	0	1	0
117.6	1	0	0	1	1	0	1	1	0	1	1
117.7	1	0	0	1	1	0	1	1	0	0	1
117.8	1	0	0	1	1	0	0	1	0	0	1
117.9	1	0	0	1	1	0	0	1	0	1	1
118.0	1	0	0	1	1	0	0	1	0	1	0
118.1	1	0	0	1	1	0	0	1	1	1	0
118.2	1	0	0	1	1	0	0	1	1	0	0
118.3	1	0	0	1	1	0	0	0	1	0	0
118.4	1	0	0	1	1	0	0	0	1	1	0
118.5	1	0	0	1	1	0	0	0	0	1	0
118.6	1	0	0	1	1	0	0	0	0	1	1
118.7	1	0	0	1	1	0	0	0	0	0	1
118.8	1	0	0	0	1	0	0	0	0	0	1
118.9	1	0	0	0	1	0	0	0	0	1	1
119.0	1	0	0	0	1	0	0	0	0	1	0
119.1	1	0	0	0	1	0	0	0	1	1	0
119.2	1	0	0	0	1	0	0	0	1	0	0



RANGE	PULSE POSITION										
Altitude in Thousands	D <sub>2</sub>	D <sub>4</sub> and SPI	A <sub>1</sub>	A <sub>2</sub>	A <sub>4</sub>	B <sub>1</sub>	B <sub>2</sub>	B <sub>4</sub>	C <sub>1</sub>	C <sub>2</sub>	C <sub>4</sub>
119.3	1	0	0	0	1	0	0	1	1	0	0
119.4	1	0	0	0	1	0	0	1	1	1	0
119.5	1	0	0	0	1	0	0	1	0	1	0
119.6	1	0	0	0	1	0	0	1	0	1	1
119.7	1	0	0	0	1	0	0	1	0	0	1
119.8	1	0	0	0	1	0	1	1	0	0	1
119.9	1	0	0	0	1	0	1	1	0	1	1
120.0	1	0	0	0	1	0	1	1	0	1	0
120.1	1	0	0	0	1	0	1	1	1	1	0
120.2	1	0	0	0	1	0	1	1	1	0	0
120.3	1	0	0	0	1	0	1	0	1	0	0
120.4	1	0	0	0	1	0	1	0	1	1	0
120.5	1	0	0	0	1	0	1	0	0	1	0
120.6	1	0	0	0	1	0	1	0	0	1	1
120.7	1	0	0	0	1	0	1	0	0	0	1
120.8	1	0	0	0	1	1	1	0	0	0	1
120.9	1	0	0	0	1	1	1	0	0	1	1
121.0	1	0	0	0	1	1	1	0	0	1	0
121.1	1	0	0	0	1	1	1	0	1	1	0
121.2	1	0	0	0	1	1	1	0	1	0	0
121.3	1	0	0	0	1	1	1	1	1	0	0
121.4	1	0	0	0	1	1	1	1	1	1	0
121.5	1	0	0	0	1	1	1	1	0	1	0
121.6	1	0	0	0	1	1	1	1	0	1	1
121.7	1	0	0	0	1	1	1	1	0	0	1
121.8	1	0	0	0	1	1	0	1	0	0	1
121.9	1	0	0	0	1	1	0	1	0	1	1
122.0	1	0	0	0	1	1	0	1	0	1	0
122.1	1	0	0	0	1	1	0	1	1	1	0
122.2	1	0	0	0	1	1	0	1	1	0	0

RANGE	PULSE POSITION										
Altitude in Thousands	D <sub>2</sub>	D <sub>4</sub> and SPI	A <sub>1</sub>	A <sub>2</sub>	A <sub>4</sub>	B <sub>1</sub>	B <sub>2</sub>	B <sub>4</sub>	C <sub>1</sub>	C <sub>2</sub>	C <sub>4</sub>
122.3	1	0	0	0	1	1	0	0	1	0	0
122.4	1	0	0	0	1	1	0	0	1	1	0
122.5	1	0	0	0	1	1	0	0	0	1	0
122.6	1	0	0	0	1	1	0	0	0	1	1
122.7	1	0	0	0	1	1	0	0	0	0	1
122.8	1	0	0	0	0	1	0	0	0	0	1
122.9	1	0	0	0	0	1	0	0	0	1	1
123.0	1	0	0	0	0	1	0	0	0	1	0
123.1	1	0	0	0	0	1	0	0	1	1	0
123.2	1	0	0	0	0	1	0	0	1	0	0
123.3	1	0	0	0	0	1	0	1	1	0	0
123.4	1	0	0	0	0	1	0	1	1	1	0
123.5	1	0	0	0	0	1	0	1	0	1	0
123.6	1	0	0	0	0	1	0	1	0	1	1
123.7	1	0	0	0	0	1	0	1	0	0	1
123.8	1	0	0	0	0	1	1	1	0	0	1
123.9	1	0	0	0	0	1	1	1	0	1	1
124.0	1	0	0	0	0	1	1	1	0	1	0
124.1	1	0	0	0	0	1	1	1	1	1	0
124.2	1	0	0	0	0	1	1	1	1	0	0
124.3	1	0	0	0	0	1	1	0	1	0	0
124.4	1	0	0	0	0	1	1	0	1	1	0
124.5	1	0	0	0	0	1	1	0	0	1	0
124.6	1	0	0	0	0	1	1	0	0	1	1
124.7	1	0	0	0	0	1	1	0	0	0	1
124.8	1	0	0	0	0	0	1	0	0	0	1
124.9	1	0	0	0	0	0	1	0	0	1	1
125.0	1	0	0	0	0	0	1	0	0	1	0
125.1	1	0	0	0	0	0	1	0	1	1	0
125.2	1	0	0	0	0	0	1	0	1	0	0

RANGE	PULSE POSITION											
	Altitude in Thousands	D <sub>2</sub>	D <sub>4</sub> and SPI	A <sub>1</sub>	A <sub>2</sub>	A <sub>4</sub>	B <sub>1</sub>	B <sub>2</sub>	B <sub>4</sub>	C <sub>1</sub>	C <sub>2</sub>	C <sub>4</sub>
125.3	1	0	0	0	0	0	0	1	1	1	0	0
125.4	1	0	0	0	0	0	0	1	1	1	1	0
125.5	1	0	0	0	0	0	0	1	1	0	1	0
125.6	1	0	0	0	0	0	0	1	1	0	1	1
125.7	1	0	0	0	0	0	0	1	1	0	0	1
125.8	1	0	0	0	0	0	0	0	1	0	0	1
125.9	1	0	0	0	0	0	0	0	1	0	1	1
126.0	1	0	0	0	0	0	0	0	1	0	1	0
126.1	1	0	0	0	0	0	0	0	1	1	1	0
126.2	1	0	0	0	0	0	0	0	1	1	0	0
126.3	1	0	0	0	0	0	0	0	0	1	0	0
126.4	1	0	0	0	0	0	0	0	0	1	1	0
126.5	1	0	0	0	0	0	0	0	0	0	1	0
126.6	1	0	0	0	0	0	0	0	0	0	1	1
126.7	1	0	0	0	0	0	0	0	0	0	0	1

# ATCRBS INTERROGATION MODES

## MODE APPLICATION

## CHARACTERISTIC

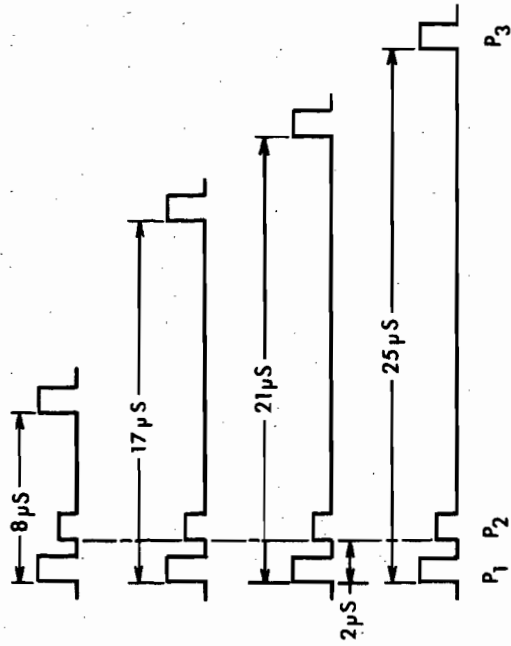

3/A COMMON (ATC)

B CIVIL (ATC)  
(NOT REQUIRED FOR U.S. OPERATION)

C CIVIL (ALTITUDE)

D CIVIL (UNASSIGNED)

## TRANSPONDER REPLY CODES



SPACING ( $\mu s$ ) LEADING EDGE TO LEADING EDGE	0	1.45	2.9	4.35	5.8	7.25	8.7	10.15	11.6	13.05	14.5	15.95	17.4	18.85	20.3
PULSE NOMENCLATURE	F <sub>1</sub>	C <sub>1</sub>	A <sub>1</sub>	C <sub>2</sub>	A <sub>2</sub>	C <sub>4</sub>	A <sub>4</sub>	X	B <sub>1</sub>	D <sub>1</sub>	B <sub>2</sub>	D <sub>2</sub>	B <sub>4</sub>	D <sub>4</sub>	F <sub>2</sub>