

FUNDAMENTALS OF THERMOMETRY PART VI

THERMISTOR THERMOMETERS

by Henry E. Sostmann

and Philip D. Metz

ABSTRACT

Thermistors are a useful and important class of electrical thermometer, with a transfer function of resistance versus temperature. The resistance-temperature relationship is usually highly non-linear, and much effort has been given to the invention of linearizing circuitry. In the most commonly used types, the coefficient of resistance change is negative; that is, higher temperatures result in higher conduction (lower resistance). (We will ignore positive temperature coefficient thermistors, which have little metrological significance). Quality of performance varies widely, in terms of interchangeability, stability, temperature range, and other characteristics. Consideration here will be given only to classes of thermistor which are of interest to the metrologist, but it is worth mentioning that there is a very large number of cruder types, and the number of thermistors produced by all producers in a given year is perhaps in the millions. We will also not consider here, except in a discussion of applications, the many configurations of sheathed, encapsulated, etc., thermistor temperature probes which are available in the marketplace.

THEORY OF OPERATION

Figure 1 illustrates the property of intrinsic conductivity in a semiconducting solid. In the vicinity of 0 K, all electrons are captured in the valence band, and the conduction band is empty. With increasing temperature, electron movement into the conduction band increases, leaving holes in the valence band. The equilibrium is dynamic, with free

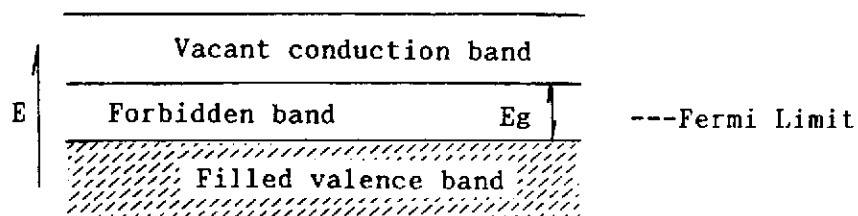

Fig 1: Band scheme for intrinsic conductivity. From Kittel, Introduction to Solid State Physics, Wiley, N. Y. 1956, 348

electrons in the conductance band recombining with holes in the valence band, and electrons in the valence band excited to the conduction band. The increase in electron mobility (therefore conductance) with increasing temperature accounts for the positive conductance, or negative temperature-resistance, characteristic.

Early experimental work with thermistors used the electronic properties of "pure" materials; germanium, silicon, diamond. I place "pure" in quotation marks, because even minute concentrations of impurities can alter the properties of the thermistor by acting as electron donors or acceptors; an activity which may be partial or complete depending upon temperature. The most common effect of dopants in pure materials is to decrease the temperature coefficient of resistance.

COMMERCIAL THERMISTORS; MATERIALS AND FABRICATION

Pure materials are seldom used in commercially distributed thermistors, which are extrinsic devices. The usual materials are metal oxides, or complex oxide systems such as spinels. In these compounds defective crystal structures, and the mutual reactions of the constituents, abetted by heat applied in fabrication and/or in use, can play a significant role in the conductance mechanism.

Typical materials are oxides of manganese, nickel, cobalt, copper, iron and titanium. Any of these individual materials may be doped with others to obtain a variety of temperature-resistance characteristics. The powdered materials are combined, ground together in ball mills (which may add their own contribution of impurity), constituted to pasty form with organic liquids (for bead thermistors) or with binders, such as acrylic (for disc thermistors), dried into beads or punched into disks, and sintered to form a physically relatively stable material.

From this description, it will be evident that the thermistor material is physically, chemically and electronically an extremely complex system, whose properties continue to defy exact description, and in general the manufacturer makes no attempt to gauge or control its properties by theoretical analysis. Practical production of useful thermistors depends upon a great deal of experience, adjustments in mix and fabrication, the rejection of some fraction of batches produced on the basis of post-production test (fortunately at this point the costs of scrap are small), and some luck and black art. One prominent producer of premium thermistors routinely loses the touch about a month out of the year (and we well remember the panics which ensue) until the process mysteriously corrects itself.

Fortunately, lot characteristic analysis at this point lends itself well to the techniques of statistical analysis.

CLASSIFICATION - DISKS AND BEADS

While any sort of classification in so broad a range of devices is chancy, we will separate metrology-quality thermistors into two categories, disks and beads. These two types have, in general, differing methods of production and different characteristics.

The process of making disk thermistors is illustrated in Fig. 2.

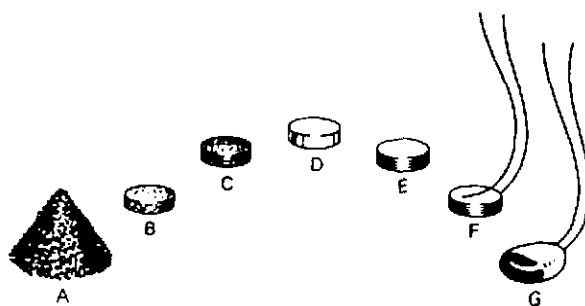

Fig 2: Steps in the manufacture of a disk thermistor. A, ball-milled powder; B, pressed disk; C, sintered disk; D, silvered disk; E, edge-ground disk; F, lead wires attached; G, epoxy-coated (courtesy YSI Inc.)

In 2A, a metal oxide, for example manganese oxide, has been combined with a suitable dopant, for example nickel oxide, and the materials have been ground together to a fine powder of specific mesh size in a ball mill. Some acrylic has been added to the mix to make it somewhat self-adherent.

In 2B, the powder has been compacted into a fragile disk. The dimensions of the disk may vary with manufacturer and type, but the order of magnitude is 2.5 mm diameter by 0.5 mm thick.

In 2C, the disk has been sintered by exposure to heat, usually above 1000°C. The rate at which the boat of disks (perhaps several thousand at once) is inserted into the furnace, the location in the furnace zone, the dwell time at temperature, the atmosphere of the furnace (and perhaps its state of contamination from previous batches or other sources), the rate of cool-down or withdrawal, are all part of the manufacturer's arcane science; usually the same procedure produces the same results, and occasionally it doesn't. However, at this point, samples can

be taken from the batch and checked, principally for consistency of dR/dt . No later process can modify the slope, if it is wrong at this stage; the batch must be scrapped, and another try made, with modifications of technique and appropriate incantations.

In 2D, the disk has been coated with a silver frit and the frit fired in place. The purpose of the frit is to permit attachment of lead wires by soldering or pressure bonding. The silver, it will be noted, is applied overall, and tends to coat the cylindrical as well as the plane surfaces of the disk (a direct electrical short), and so in 2E the edges must be ground free of silver.

It is at this point that disk thermistors can be given their most important characteristic; that is, interchangeability of units with respect to R_0 and R_t . Assuming that the proper slope characteristic has been achieved in previous steps, the individual disks are clamped in a fixture immersed in a temperature bath (often at 25°C) and material is removed from one edge by fine grinding, while the resistance is monitored in comparison with a standard thermistor at the same temperature. Thermistors can thus be made interchangeable to $\pm 0.1^\circ\text{C}$, $\pm 0.05^\circ\text{C}$, or some similar desirable level.

In 2F, lead wires are attached by some commonplace means. One means is to dip-solder them. Since soldering heat has been applied, it is prudent to evaluate the batch again after lead attachment. Other methods involve conductive adhesives, various forms of spot-welding, and compression bonds.

Soldering is usually accomplished with a lead-tin solder alloy already partially saturated with silver to avoid scavenging the silver coating. The phenomenon of scavenging results from the solubility of silver in tin, which increases with temperature, and scavenges the silver coating from the substrate. Excess silver in the alloy is equally to be avoided. (The phenomenon of scavenging can also be observed with gold) [1].

In 2G, a protective epoxy coating has been applied, usually with color-coding to indicate the dR/dT type of thermistor. It is then the custom of at least one manufacturer to evaluate the product, on a 100% basis, at 3 temperatures not including 25°C. In this manner, thermistors are produced with close zero and slope conformity, in a wide range of base resistances. Commercial thermistors are available with 25°C resistance of 100 Ω , 300 Ω , 1000 Ω ... 1 M Ω . Fig. 3 shows the relative ratios R_t/R_{25} for several of the common types.

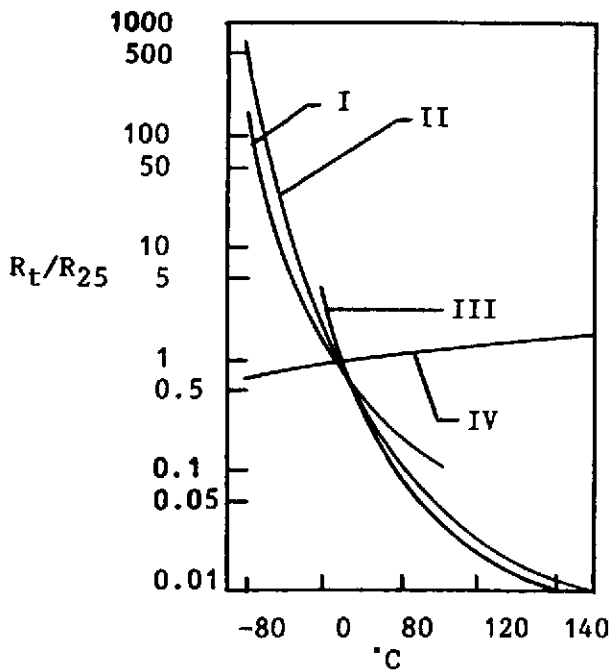

Fig 3: $R_t/R(25)$ for several common thermistor types. I = 100Ω, II = 2252Ω, 10KΩ, 100KΩ, III = 1MΩ at 25°C. IV = R_t/R_o for a platinum resistance thermometer.

For comparison, the R_t/R_o curve of a platinum resistance thermometer is also shown. At this scale, these curves must be taken to be illustrative rather than quantitative.

Here is evident one of the great strengths of thermistors; a large change in resistance is realized for a relatively small change in temperature over the portion of its curve where it is most sensitive.

The change in resistance of a thermistor is about 4% of the immediate resistance per 1°C change, while the change in resistance of a platinum resistance thermometer is about 0.4% per °C of the resistance at 0°C.

The process of manufacturing bead thermistors is illustrated in Fig. 4.

The process of compounding the powder is essentially as in 2A for disks. The powder is compounded usually not with an acrylic binder but with some volatile organic, to produce a manageable slurry.

In Fig 4, lead wires, of a material which will tolerate the sintering temperature, are held in slight tension and parallel to each other at a distance which is dictated by the desired size of the bead. Slurry is

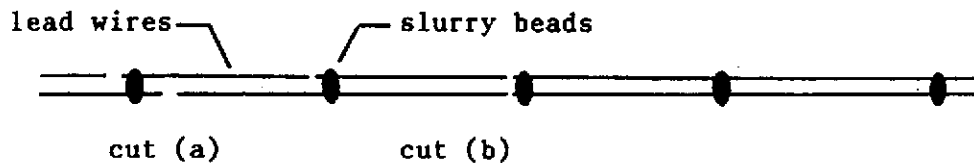

Fig 4: Manufacture of bead thermistors. The process is described in the text. The lead wires may be cut in several styles (a), (b).

applied between the lead wires. The system is then dried and sintered, in a controlled atmosphere, at a temperature which will result in sufficient density to hold the thermistor material and the lead wires together. The bead and the adjacent wires are then cut into a desired lead configuration, and the surface of the bead and a short length of the emergent wires are coated with a thin glass film (alternatively, sealed within the tip of a thin-walled glass tube) for mechanical security.

The various forms of bead which can be made by this process often result in a sensitive element smaller than possible in disc production; but as a generality, beads cannot be made to close temperature/resistance tolerances (interchangeable) and can satisfy such requirements only by test and selection after fabrication, or by a network of pads and shunts (which reduce sensitivity). Typical unit-to-unit interchangeability for bead thermistors is $\pm 20\%$.

Other forms of thermistor are common. These are short rods, flakes and chips (of small mass but larger area, suitable, e.g., for infrared detectors), washers and films. Thermistors have been formed in place by vapor deposition; such forms will not be considered here, since their metrology applications are limited (but films have been used in low-mass sensitive bolometers).

THE CHOICE - DISKS OR BEADS?

The better choice is based upon the application and the properties required from the sensor. However all choices involve trade-offs; for example, a bead thermistor, which might be chosen because it is very small, will not satisfy a requirement for interchangeability, and will have a lower dissipation constant (higher self-heat), than a disk. Table 1 will attempt to summarize salient considerations.

1: Size. Often an advantage of thermistor temperature sensors is the small size of the sensitive element; its ability to make a spot measurement. Bead thermistors can be made much smaller than discs.

2: Stability. Legend has it that bead thermistors are more stable than disk thermistors, and early experience seems to confirm this [2]. The explanation for this superior stability is probably the result of the customary glass encapsulation of bead thermistors, which has the following consequences:

(a) The semiconductor bead and its lead attachments are an hermetically sealed system, preventing oxidation of the attachment contact.

TABLE 1 - SOME CHARACTERISTICS OF THERMISTORS

TYPE	DIAMETER INCH	MAX POWER MILLIWATT	MAX CONTINUOUS TEMPERATURE DEG C	25 DEG C RESISTANCE RANGES	TIME CONSTANT (1)		DISSIPATION CONSTANT (2)			INTERCH?	SOURCE
					AIR SEC	WATER MILLISBC	AIR MILLIWATTS PER DEG C	WATER PER DEG C			
SMALL BARE BEADS	0.005	4	150	1 K TO 10 MEG	0.11	4.5	0.05	0.25	+/- 20%	THERMOMETRICS	
	0.007	6	150	.3 K TO 10 MEG	0.2	6	0.07	0.35	+/- 20%		
	0.011	8	150	.3 K TO 10 MEG	0.65	11	0.095	0.47	+/- 20%		
SMALL GLASS-COATED BEADS	0.005	6	300	1 K TO 10 MEG	0.12	5	0.045	0.23	+/- 20%	THERMOMETRICS	
	0.007	8	300	1 K TO 10 MEG	0.23	7	0.06	0.3	+/- 20%		
	0.01	10	300	.3 K TO 10 MEG	0.5	10	0.09	0.45	+/- 20%		
	0.014	14	300	.3 K TO 10 MEG	1	15	0.1	0.5	+/- 20%		
LARGE GLASS-COATED BEADS	0.035	35	300	.03 K TO 20 MEG	4.5	100	.3	1.5	+/- 20%	THERMOMETRICS	
	0.043	35	300	.03 K TO 20 MEG	5.5	140	.35	2.0	+/- 20%		
EPOXY-COATED DISCS	0.095		150 150	0.1 K TO 1 MEG	10	1 SEC	1	10	+/-0.2 DEG C +/-0.1 DEG C +/-0.05 DEG C (0 TO 70 DEG)	YSI INC	
GLASS-COATED DISCS	0.125	(3)	200	2.25 K TO 30 K		2.5 SEC	4	10	AS ABOVE	YSI INC	

(1) TIME CONSTANT IS THE TIME REQUIRED TO RESPOND TO 63% OF A STEP CHANGE IN TEMPERATURE.

(2) IN MILLIWATTS PER DEGREE C TEMPERATURE RISE DUE TO SELF-HEAT

(3) DEPENDS UPON SELF-HEATING PERMITTED IN APPLICATION

INFORMATION DERIVED FROM PUBLISHED CATALOGS

THERMOMETRICS, 808 US HIGHWAY 1, EDISON, NEW JERSEY 08817, (201)-287-2870
 YSI INC, BRANNUM LANE, YELLOW SPRINGS, OHIO 45387, (513)-767-7241

There is reason to believe that some of the shift in epoxy-coated thermistors, after exposure to temperature at their upper rated limit, is due to deterioration of the contact between the thermistor surface and the contact frit.

(b) The semiconductor is constrained by the shrinkage of the glass coating, binding the grains more tightly together.

In the early days of radio, microphones were made with a carbon element. Sound pressures reoriented the contact boundaries of the carbon granules, altering the bulk resistance of the element. It is possible to find in this an analogue of the thermistor. A structure which physical constrains the grains into a constant-contact mass would produce a less sensitive microphone, and a more stable thermistor.

Recently (perhaps 10 years ago) one manufacturer of disk thermistors began manufacturing interchangeable sensors in which, after grinding to 25°C interchangeability, the assembly was glass-coated. These units have been shown to approach the stability of the best beads and offer the advantage of interchangeability, which beads do not.

Stability of any thermistor depends upon the maximum temperature to which the sensor is exposed. Reported stability for glass-coated disks is shown in Table 2.

OP TEMP*	1 MONTH	10 MONTH	100 MONTH
25°C	<0.01°C	<0.01°C	<0.01°C
70°C	<0.01°C	<0.01°C	<0.01°C
100°C	0.01°C	0.02°C	0.01°C
150°C	0.03°C	0.05°C	0.08°C
200°C	0.08°C	0.22°C	0.60°C

* Continuous operating temperature

3: Dissipation constant (self-heating). All resistive devices are subject to I^2R heating. Since they are passive circuit components, it is necessary to pass a current through them to put them to use. The inevitable result of current through a resistance is heat; the problem set for the student is to design a circuit, for the specific application, in

which the rise in temperature due to self-heat is negligible compared to the accuracy required of the measurement.

In a specified environment, dissipation is largely a function of its heat capacity and the surface area of the heated sensor which is exposed to the medium which will carry this heat away, and therefore a small element will permit dissipation of less heat than a larger one. Dissipation, of course, will be higher in flowing water (for example) than in still air. A related concept is time constant; the time required for the sensor to react to a step change in temperature; this may be thought of loosely as the inverse of dissipation constant, as the time required for the medium to transfer heat to the sensor mass.

Although lead wires of thermistors are usually of small diameter, the possibility of unwanted transfer of heat from or to the thermistor via the lead wires passing through the zone of thermal gradient (analogous to stem conduction in sheathed thermometers) cannot be ignored. The usual tests of immersion of the sensor assembly at several depths will reveal such faults.

Because the resistance-temperature coefficient is negative, one must be very cautious about self-heating thermistors. We are accustomed to the idea that self-heating of industrial platinum thermometers is, to some extent, self-limiting, since an increase in self-heat produces an increase in resistance. (It is possible to heat an industrial platinum element with a large voltage without doing any physical damage; I have heat-treated elements this way, when the rest of a probe assembly could not stand furnace temperatures). Now let us imagine a thermistor whose resistance at 25°C is 2252Ω (a value which is a *de facto* standard for medical electrical thermometers). Its self-heat factor in flowing water is 10 mW = 1.0 K of temperature rise. We apply 4.64 volts,

$$E = (P * R)^{1/2} = 4.64 \quad \text{Eq. 1}$$

and stabilize at 26°C, where the resistance has responded to a 1°C change and is now 2156Ω, but the change in resistance also involves an increment to the current passed. In the extreme circumstance, the reduction of resistance and increase of current due to self-heating can lead to a catastrophic run-away condition.

For measurements of the highest precision, it is often desirable to determine the zero-power resistance of the thermistor at temperature. This can be done by measuring the resistance at two input powers (e.g., 1 and 1x√2) and extrapolating to the resistance at zero power. The

heating effect of the applied power in the working circuit can then be estimated.

Again, for measurements of the highest precision, note must be taken of the series resistance of the thermistor lead wires. One series of disc thermistor is furnished with lead wires of #32 copper, 3 inches long, whose resistance is 0.0137Ω per inch, or 0.082Ω for the 6 inch loop. For a thermistor with nominal resistance at 25°C of 100Ω , this represents almost 0.6% of total resistance at 100°C ! In any calibration, it is important to know at what point along the lead wires the test clips were applied, unless the thermistor resistance is sufficiently high as to make lead resistance negligible.

Self-heat must be carefully considered in choosing readout instruments for thermistors. It is quite natural to think first of multi-digit multi-range digital ohmmeters. However most commercial digital ohmmeters impose excessive currents on the resistor (thermistor) being measured, and may change current with automatic range change. The meter manufacturer's operating current specifications must be carefully compared with the thermistor manufacturer's self-heat specifications to assure that self-heat errors are negligible.

4: Range of temperature. The range of temperatures over which thermistors may be used is bounded by:

(a) at the upper limit, that temperature at which physical alteration of the construction begins to be effective in shifting the sensor's characteristics. Such alteration may be the oxidation of lead wires or of the bond between the wires and the semiconducting material, or the shifting of the intergranular relationship of the material, or, more grossly, the development of cracks and vacancies. Disc thermistors with low 25°C resistance are generally limited to 100°C ; with 25°C resistances above several thousand ohms, to 150°C . Upper temperature for glass-encapsulated disks may be estimated from Table 2. Tiny bead thermistors are usually limited to 150°C , larger beads to 300°C , and special types are specified to operate as high as 400°C .

(b) at the lower limit, that temperature at which the thermistor (because its resistance becomes very high) cannot be measured effectively. For example: a thermistor which measures $10 \text{ k}\Omega$ at 25°C , and 186Ω at 150°C , reaches $7.4 \text{ M}\Omega$ at -80°C ! It has also been reported that exposure to very low temperatures (e.g., liquid nitrogen) may cause catastrophic physical changes, such as cracks, in the gross structure.

5: Cost. The cost of good thermistors is comparable to the cost of good industrial platinum elements. However additions to cost to assure quality and reliability of the unit or lot may be substantial, since they are usually costs for additional lot or unit testing. Thermistor manufacturers are equipped to perform reliability assurance testing upon need (for example, for thermistors used in space vehicles) which may involve temperature cycling, high and low temperature storage, effects of humidity, shock, vibration, etc.

THE ELECTRICAL PROPERTIES OF THERMISTORS

We are accustomed to the idea that the relationship between temperature and resistance of platinum wire thermometers is not far from linear, and can be represented for all practical purposes by a simple quadratic equation when $t \geq 0^\circ\text{C}$, and by a cubic equation when $t < 0^\circ\text{C}$, to the lower limit set for platinum resistance thermometers in various industrial standards [3]. (The relationship is more complicated for Standard Platinum Resistance Thermometers on the ITS-90) [4].

A number of attempts have been made to develop a thermistor equation based on the complex physical laws, only partly understood, which determine thermistor performance. These have generally been of the form

$$R_T = R_0 (\exp) [-\beta(1/T - 1/T_0)] \quad \text{Eq. 2}$$

None of these have proven so successful as an empirical equation proposed by Steinhart and Hart [5], which requires measurement of resistance at three temperatures:

$$1/T = A + B(\ln R) + C(\ln R)^3 \quad \text{Eq. 3}$$

where T is the Kelvin or absolute temperature. Given a restricted range of temperature, (e.g., 0° to 70°C) it has been shown that this equation affords accuracies of $\pm 0.005^\circ\text{C}$. Mangum has published a modification of the Steinhart-Hart Equation which requires four calibration temperatures and is said to afford an accuracy of $\pm 0.001^\circ\text{C}$:

$$1/T = A + B(\ln R) + C(\ln R)^2 + D(\ln R)^3 \quad \text{Eq. 4}$$

(You will see Eqs. 3 and 4 written as "log" (base 10) or "ln" (base e). It does not matter which is used provided consistency is maintained).

It is often useful to have Eq. 3 explicit in R, and this may be written as follows:

$$R = e (\exp) [(\delta - a/2)^{1/3} - (\delta + a/2)^{1/3}] \quad \text{Eq. 5}$$

where

$$a = (A - 1/T)/C, \quad \beta = B/C, \quad \delta = [(a^2/4) + (\beta^3/27)]^{1/2}$$

and A, B and C are the coefficients of Eq. 3 in $(\ln R)$. (Eq. 5 is given incorrectly in the literature of a prominent manufacturer of thermistors).

The non-linearity of thermistors has challenged a number of workers. The use of digital active circuitry, which breaks the thermistor curve at a suitable number of inflection points and assigns an appropriate slope to each line segment between these points, is easily the most flexible way to linearize a thermistor curve.

Other solutions have been applied, which do not require active circuitry. These include:

(a) Matching non-linear scales on analog readout instruments. This solution is applicable only to instruments in which the scale of the readout meter has been drawn to fit the characteristics of a specific unit thermistor, or where the thermistors intended to be used as instrument sensors are interchangeable in calibration within acceptable limits.

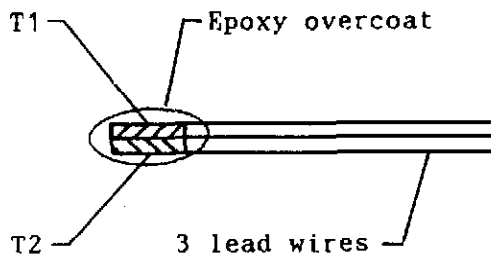

Fig 5: Construction of a Thermilinear component. T1 and T2 have different values. "Thermilinear" is a registered trade style of Yellow Springs Instr. Co. (now YSI Inc.)

(b) Thermistor composites, ("Thermilinear" composites), in which two or more thermistors are combined with suitable fixed resistors in a network having essentially linear output in terms of either voltage or resistance. Thermistors intended for network applications are usually constructed as shown in Fig. 5, but there is no electrical reason why such an integrated construction is necessary. Circuits employing thermilinear composites are shown later in this paper.

Passive networks employing thermistor composites are linear over relatively narrow temperature ranges, and have the disadvantage that

the sensitivity is much reduced, approximating that of industrial platinum resistance thermometers.

CIRCUITS EMPLOYING THERMISTORS

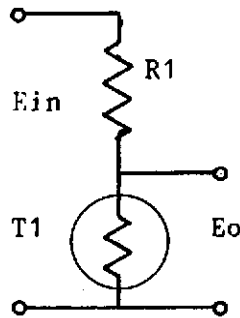

Fig 6: Elementary voltage divider with thermistor

There are of course two practical difficulties with this simple circuit, (1) any load resistance across e_o shunts R_T and (2) the output cannot be reduced to zero at any temperature.

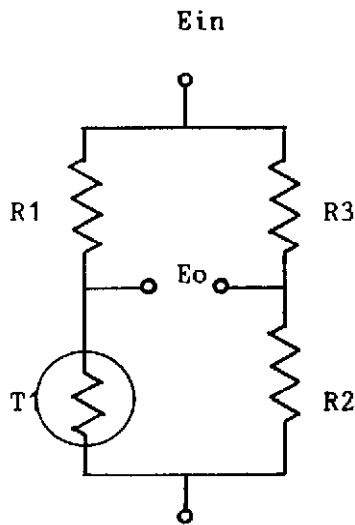

Fig 7: Bridge circuit with thermistor. R_3 may also be a thermistor for double sensitivity.

(a) The simplest circuit employing thermistors for temperature measurement is the elementary voltage divider, shown in Fig. 6, in which an applied voltage is divided by a fixed resistor R_1 and a thermistor R_T . The network current is

$$i_n = e_{in}/(R_1 + R_T) \quad \text{Eq. 6}$$

and the output voltage is

$$e_o = R_T e_{in}/(R_1 + R_T) \quad \text{Eq. 7}$$

(b) Fig. 7 shows a bridge configuration in which the thermistor is one of four resistances. This circuit can be balanced to zero output at any desired temperature by adjustment of R_3 .

$$e_{in} = [(R_1 + R_2)(R_3 + R_T)] / (R_1 + R_2 + R_3 + R_T) \quad \text{Eq. 8}$$

$$i_1 = e_{in}/(R_1 + R_2) \quad \text{Eq. 9a}$$

$$i_2 = e_{in}/(R_3 + R_T) \quad \text{Eq. 9b}$$

$$e_o = e_{o1} - e_{o2} \quad \text{Eq. 10}$$

$$= R_2(e_{in}/(R_1 + R_2)) - R_3(e_{in}/(R_3 + R_T)) \quad \text{Eq. 11}$$

In (a) and (b) above it is assumed that e_{in} is obtained from a constant-current source.

Many other circuits suggest themselves; for example, it is possible to double the sensitivity of the bridge of Fig. 7 by replacing R_3 with a thermistor located in the same temperature environment as R_T , provided both thermistors have the same characteristics.

The resistance-temperature characteristic of a thermistor may be made more linear by shunting it with a fixed resistance. We will use a specific example to illustrate this.

Choose a thermistor such as YSI's 44004. The nominal resistance of this thermistor at five temperatures is shown in Column 2 of below. Subtracting the resistance at 20°C from each of the higher resistances, we obtain the increments of resistance (Column 3), and show in Column 4 the deviation (in terms of temperature) from a straight line through the endpoints.

Shunting the thermistor with a fixed resistor of 3471.8 Ω , we obtain a set of values for the parallel network, Column 5, with the resistance increments shown in Column 6, and the deviation from a straight line, shown in Column 7.

UNSHUNTED THERMISTOR				3471.8 Ω SHUNT		
1	2	3	4	5	6	7
t, °C	R(th)	Incr R	Non-lin °C	R(net)	Incr R	Non-lin °C
0	7355	4541	0.00	2358.5	804.27	0.00
5	5719	2905	-2.2	2160.3	606.10	0.07
10	4482	1668	-2.65	1956.4	402.13	0.00
15	3539	725	-1.81	1752.5	198.30	-0.07
20	2814	0	0.00	1554.2	0.00	0.00

Two effects are obvious; first, that the network is more linear than the unshunted thermistor, and second, that the sensitivity has been reduced (from 4541 ohms change for 20°C to 804 ohms change for the same temperature interval).

Consideration of the dual sign of the nonlinearity of the shunted thermistor will suggest that the non-linearity will be larger as the temperature range is extended. At the higher temperature the fixed resistor

will be too large, and at the lower temperature it will be too small. If a second thermistor is substituted for the fixed resistor, and a simple network of fixed resistors added, the range can be extended much further with reasonable linearity. Two such circuits are shown as Figs. 8a and 8b. Instructions for calculating the appropriate thermistor and fixed resistance values for various temperature ranges are offered by manufacturers [6]. Unfortunately, there is no passive solution for the reduced sensitivity.

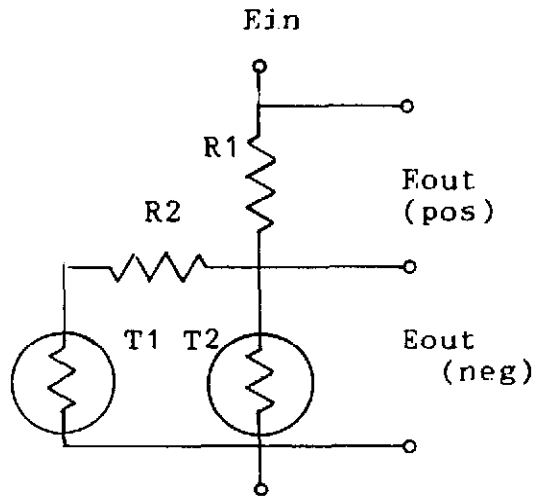

Fig 8a: Thermilinear network with voltage output.
 "pos" = positive with t ;
 "neg" = negative with t .

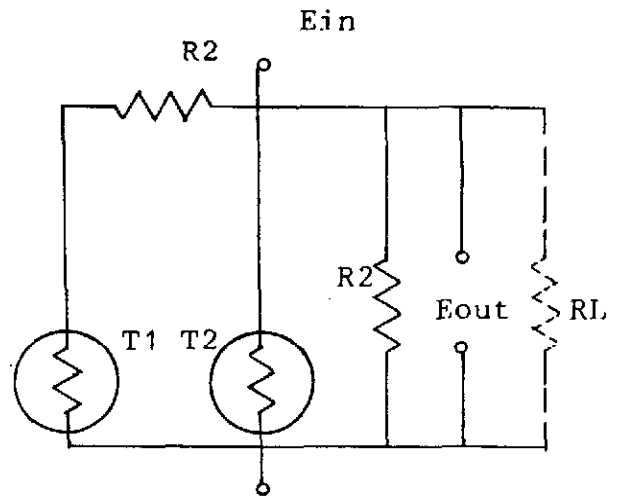

Fig 8b: Thermilinear network with resistance output.
 R_L = load resistance, which must be known and fixed.

WORKING CONFIGURATIONS FOR THERMISTORS

The possible configurations of mounting, sheath, etc., usable with thermistor sensors are limited largely by the imagination of the designer. They range from simply potting the thermistor into a hole (but not with an acetic-acid-curing silicone; acetic acid has been shown to cause shifts in epoxy-coated thermistors), mounting the thermistor centered inside a blackened ping-pong ball to integrate radiant energy, and on to relatively sophisticated enclosures. An assortment of commercially-available configurations is shown in Fig. 9.

A prominent use of thermistor probes is in medical thermometry, during procedures or as patient monitoring systems, in oesophageal or rectal sites or in surgically created body cavities. Both single thermistors, having a nonlinear characteristic, and thermilinear composites are employed with readout instrumentation, limit controls,

Fig. 9a: A single epoxy-coated thermistor with bare lead wires. The most common type for further configuration by the user. The common configuration for circuit use as a temperature compensator

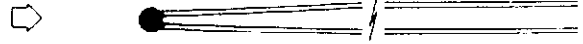
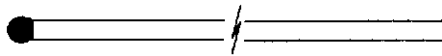

Fig 9b: A single thermistor or thermilinear composite with PVC-covered two or three wire cable. Most common type for oesophageal or rectal medical use. Usually moisture resistant and sterilizable-but specify if required!

Fig 9c: Thermistor or thermilinear composite in stainless sheath, 1/8 inch minimum diameter. Lead junction with sheath may give water immersion problems. "Hermetic" junctions may be specified.



Fig. 9d: A single thermistor or composite in a steel sheath with pipe plug fitting for insertion into a closed cavity. This can place the lead safely out of a wet or otherwise problematical environment

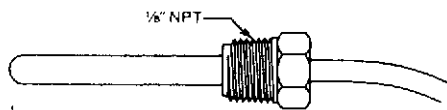

Fig. 9e: Air temperature probe: a thermistor or thermilinear composite within a protective cage.

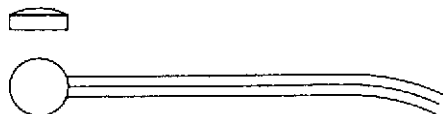
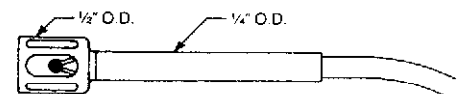
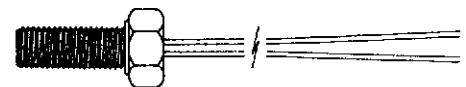

Fig. 9f: A surface temperature probe; steel cup, epoxy filled. For skin-surface temperature in medicine, air-conditioning ducts, and general use.

Fig 9g: Thermistor mounted in a machine screw, which may be any material and as small as No. 8-32. An example of the versatility available in thermistor enclosure configurations.



alarm systems, etc., specifically designed for this purpose. Resistance versus temperature characteristics for these sensors almost universally follow the characteristic R/t tables first published by the Yellow Springs Instrument Company, the pioneer in this field. Recently, propelled by concerns about cross-infection (and perhaps also cost) a large number of disposable or single-use medical thermistor probes have come into the marketplace. These are individually packaged in sealed and (usually) radiation-sterilized form.

So prevalent are readout instruments calibrated for either a thermistor sensor with a 25°C resistance of 2252 Ω or a thermilinear network, that one manufacturer, wishing to take advantage of the lower materials cost of disposable thermocouple (as opposed to thermistor) probes, furnishes a black box in which the output of the thermocouple is amplified and used to heat a 2252 Ω thermistor, whose resistance output is then presented to a conventional readout instrument intended for thermistor input!

Medical thermometry has been the subject of intense standardization activity over the past 10 years, propelled by the effort to develop common standards for a united Europe (which will also govern imports into the EEC). The most immediately important example of this is the work of Secretariat SP12/SR7 of the Organization International de Metrologie Legal, the Physikalisch-Technische Bundesanstalt of Germany holding the primary responsibility [7]. This Standard for medical electrical thermometers for continuous use (as opposed to "fever" thermometers) is expected to be adopted by the 52 nations of the OIML Treaty, so that it will, in effect, require conformance by all manufacturers of affected equipment who wish to sell in the world market. Also any medical device is subject, in the United States, to the rules of the Food and Drug Administration, (and most other countries also regulate such devices).

The medical field has stimulated the development of a number of specialized temperature probes. Among these may be mentioned tiny probes using bead thermistors, which can be inserted into portions of the brain during cryosurgery; beads mounted in hypodermic needles, for insertion into veins; skin-surface temperature probes; probes whose lead wires are radio-opaque so that their passage through the body's canals can be guided by fluoroscopy; and thermistors included as temperature sensors in multi-purpose devices such as stethoscopic catheters, for observing body core sounds and temperatures. In such probes, compatibility with human tissue and the ability to withstand sterilization are often prominent considerations.

CALIBRATION OF THERMISTOR THERMOMETERS

Because of the limited temperature range of thermistor thermometers (typically -40° to $+150^{\circ}\text{C}$) primary calibration can be carried out simply and economically, using only, for example, the water triple point and the gallium point [8]. By such techniques, uncertainties of less than 2 mK can be achieved. Also, the usual small size of thermistor sensors permits calibration in Isotech "slim" cells and benchtop equipment such as the Isotech Oceanus block bath.

Comparison calibrations can be made in the customary fluid baths, etc, respecting the possible differences in locus, dissipation, stem effect, etc., between the small thermistor sensor and whatever is used as the standard.

THERMISTORS USED SELF-HEATED

While normally every effort is made to achieve circuitry in which the power presented to the thermistor is sufficiently low that any I^2R heating is negligible, there are situations in which thermistors can be self-heated appreciably and to advantage. Most of these are used to monitor or control some situation which can vary the dissipation constant of the thermistor as a function of changes in the medium or in the power applied. Many of them depend upon a two-thermistor network in, which one thermistor is kept in a relatively constant environment while the second responds to a change. We will simply list some of these applications:

Level controls (dissipation varies whether in gas or fluid)

Gas or vapor pressure (dissipation varies with medium density.)

Flow (dissipation varies the velocity of the flowing medium). An interesting application is the vortex-shedding flow meter, in which the flowing material is rapidly directed to one side or another of a blade, being turbulent on one side and laminar on the other, and dissipating differently).

Gas analysis and chromatography

Automatic switching and voltage control.

Any use of thermistors in a self-heated mode must be designed below the level of thermal runaway!

FOOTNOTES AND REFERENCES

- [1] H. H. Manko, *Solders and Soldering*, p. 106, McGraw Hill (1964)
- [2] S. D. Wood, B. W. Mangum, J. J. Filliben, S. B. Tillett, An investigation of the stability of thermistors, *J. Res. Natl. Bur. Stand.* 83, 247 (1978)
- [3] See "R vs t tables for industrial platinum resistance thermometers" in this issue of the *Isotech Journal of Thermometry*.
- [4] See H. Preston-Thomas, The International Temperature Scale of 1990, *Metrologia* 27, 3-10 (1990), also, Report on the 17th Session of the Consultative Committee on Thermometry, *NIST J. Research*, 95, 69-77 (1990), including errata in the *Metrologia* article.
- [5] I. S. Steinhart, S. R. Hart, *Deep Sea Research*, 15, 497 (1968)
- [6] e.g.: *YSI Inc. (formerly Yellow Springs Instrument Co)*, PO Box 279, Yellow Springs, Ohio 45387; *Thermometrics Inc.*, 808 U. S. Highway 1, Edison, New Jersey 08817; *Keystone Carbon Company*, 967 Windfall Road, St. Mary's, Pennsylvania 15857.
- [7] Third draft, OIML SP12/SR7, *Medical electrical thermometers for continuous use*; International Organization for Legal Metrology, 17 Rue Turgot, Paris. (One of us - HES - is a principal author of this Standard, and can furnish copies of documents, consulting services and assistance in obtaining official pattern approval, to interested parties; also advice on the introduction of new medical thermometers and monitoring systems under the regulations of the U. S. Food and Drug Administration, domestically and for export).
- [8] For a complete description of such a calibration system, please see P. Klasmeier, The water triple point and gallium point in secondary laboratories in Germany, *Isotech Journal of Thermometry*, Vol. 3 No. 1, p 37-42 (1992). Reprint copies are available, if you missed it.

For a comprehensive reference on semiconducting temperature sensors, not limited to thermistors, one could do no better than to consult H. B. Sachse, *Semiconducting temperature sensors and their applications*, John Wiley & Sons, Inc., New York (1975).

THERMISTOR DEVELOPMENT

AT THE YELLOW SPRINGS INSTRUMENT CO., INC.

by Hardy W. Trolander

Prior to 1953, the Yellow Springs Instrument Company (YSI), a boot-strap operation then five years old, had produced several experimental electronic thermometers incorporating thermistors as their temperature sensing elements.

The first of these instrument was intended to measure the surface (skin) temperature of the human body. It was designed for and in conjunction with the Fels Institute, a physiology-research organization located also in Yellow Springs, Ohio. The instrument was only marginally successful, because the thermistor employed was a large disc with a high thermal mass. Since the skin is itself a rather good insulator, the tail wagged the dog; instead of measuring skin temperature, the thermistor measured, in reality, its own temperature, at the same time increasing or decreasing the temperature of the surface whose temperature it was supposed to measure. A lesson learned!

The second instrument [1] was somewhat more successful. It was designed to measure human body core temperature; that is, relatively deep rectal temperature. This is a body site of considerable thermal mass, and its temperature was not affected appreciably by the sensor and its lead wires. One of the large disk thermistors was filed to a lozenge shape to reduce its irritation upon insertion. The removal of material of course increased the resistance of the thermistor, and the Wheatstone bridge of the instrument was rebalanced to match the resistance of the altered thermistor.

The application of this instrument proved to be of considerable significance, for it was employed in what may have been the first successful use of a heart-lung machine on a human patient. This led to serial production of the instrument, after superficial refinements to make it easier to produce and easier to use. A substantial drawback remained: the Wheatstone bridge of each instrument had to be individually calibrated to match its specific thermistor sensor. (Thermistors at that time were available matched in resistance to about ± 2 °C, while the medical applications required readings to be accurate to $\pm 0.1 - 0.2$ °C. Thus probes, which did not endure as long as the associated instrument, were in no sense interchangeable).

Other applications for measurement of biological temperatures, over a vari-

ety of temperature ranges and measurement sites, soon appeared. Sensor failures, due to such things as mechanical over-stress, made it necessary that instruments be recalibrated to the value of the replacement sensor with each change of probe. Many applications utilized a number of probes, each feeding a separate bridge, and each of these bridges required readjustment when a new probe was installed. Most users did not have the competence nor the equipment to do this readjustment, and this necessitated that each instrument be returned to YSI when a probe was replaced. The sensitivity of the thermistor over a narrow range of temperatures made them the sensor of choice, but it soon became very clear that commercially-available thermistor tolerances and matching would severely limit their application in many biological and medical applications.

Years ago, as a boy, the author purchased his first volt-ohm-milliammeter, and of course took it out of its case to see what was inside. He noticed that several of the carbon resistors had slots filed into their bodies. These were loose-tolerance resistors, too loose for the claimed accuracy of the instrument, but they had been tuned in resistance by removing material from the sectional area, to adjust their resistance to the more precise values required. The manufacturer of the meter had only to assure that he began with carbon resistors whose unadjusted resistances were lower than nominal. Evidently the manufacturer found this cost-effective [see ED NOTE].

The recollection of the adjusted carbon resistors, coupled with the filed-for-comfort thermistors of the rectal probes, suggested that close-tolerance thermistors could be made from low-tolerance units that were on the low side of their tolerance band, by removing material until the required close-tolerance value was reached. However the tedious process of hand-filing and measuring over the multiple passes needed to bring the thermistor up to the desired value of resistance at a specific temperature proved impractical. Also, we at YSI had very little experience with any but rough-and-ready temperature measurement and bath temperature control, and thus were in no position to develop a process that required any degree of sophistication in what was for us a new field. In retrospect that was probably a blessing. The solution (extremely simple, as it turned out) was to design a fixture to hold the unadjusted thermistor blank with one edge extending outward, so that material could be removed from the extended edge of the blank using an abrasive disc mounted on a flexible-shaft grinder. The jaws of the clamp were electrically and thermally isolated from the main body of the fixture. One jaw of the clamp contained a second thermistor, hand-adjusted to the required value, in close electrical and thermal contact with the thermistor being ground. Three connecting leads were provided, so that the two thermistors formed half of a Wheatstone bridge. The earliest fixture was a simple modification of needle-nosed pliers to

incorporate insulated tips, spring-loaded to hold the thermistor that was being ground; and the analog-meter bridge readout was in terms of in-or-out-of-tolerance. The end of the pliers the thermistors was mounted inside a 3-1/2" i.d. lucite tube to avoid effects from stray breezes.

Since both thermistors had similar slope (R vs T) characteristics, they quickly equilibrated to a common temperature when the grinder was withdrawn. Small differences between the value of the control thermistor resistance and the desired value of the thermistor being ground were readily accommodated by tweaking the passive side of the half-bridge.

The use of this fixture resulted in an improvement of almost two orders of magnitude of resistance vs temperature tolerance over then-available disc thermistors. They now became interchangeable and reproducible to within $\pm 0.1^\circ\text{C}$ over the medical range of 20° to 40°C . Fig. 1 (courtesy of YSI) illustrates a thermistor following grinding, the attachment of lead wires and encapsulation. The view at the right illustrates the ground edge of the thermistor. This fixture, and the process, was granted a patent ([2] and Fig. 2).

Almost immediately biological and environmental applications were found that required ranges of measurement (spans of temperature) larger than that of the initial medical range of application. The supplier of YSI's disc thermistors was asked for best practicable tolerances on slope, and YSI's adjusted disc thermistors of various types were then assigned tolerances for their resistance vs temperature characteristics over a more extended temperature range. These specifications were published. However the supplier, who really preferred customers requiring larger volumes of product, did not meet the specifications consistently for our limited-quantity needs. YSI then began its own laboratory production of disc thermistors, developed the controls necessary to meet its slope tolerances, and conveyed these results to the supplier. But YSI's low volume requirements did not provide the supplier with adequate economic justification for installing the closer production controls required.

We parted company amicably, and YSI established its own pilot plant, which was soon able to meet (and exceed) its needs for the production of precision interchangeable thermistors. At that point, we produced only one value of thermistor for our various temperature sensors. It has (and has) a nominal value of $2252\ \Omega$ at 25°C with sensitivity of $99\ \Omega$ per $^\circ\text{C}$ at that temperature. (This thermistor has continued in production up to the present, and is used in all of YSI's Series 400 temperature probes. Given the relatively short life in the marketplace of most semiconductor devices, it has achieved considerable durability)!

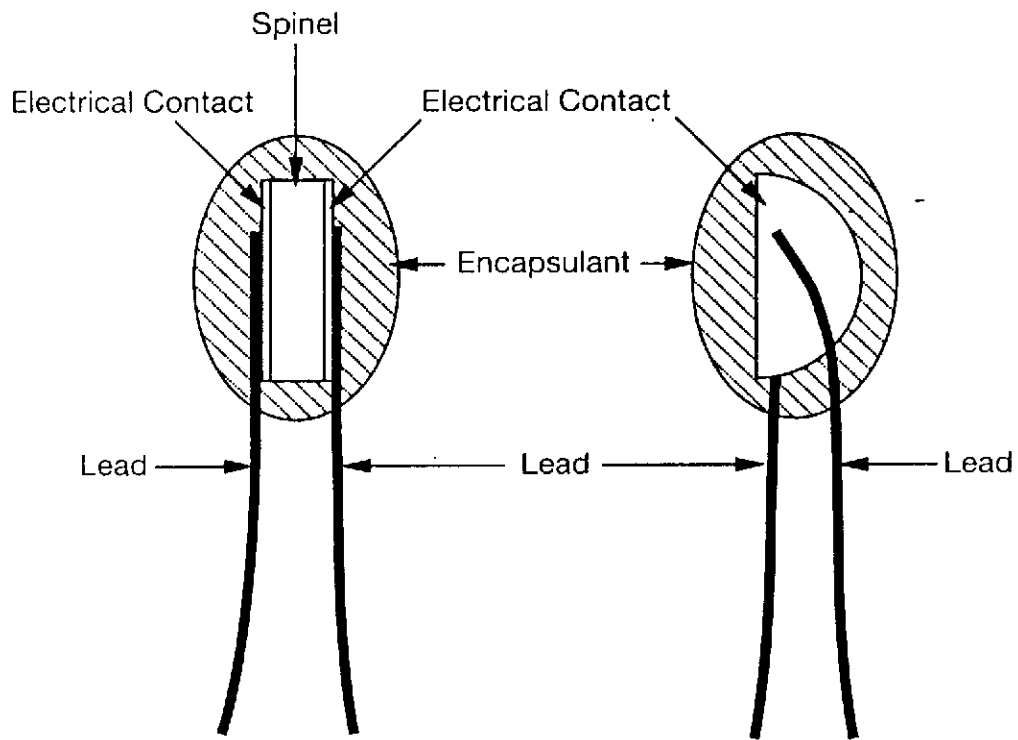

FIGURE 1

The construction of a YSI disk thermistor (courtesy YSI, Inc.)

Feb. 7, 1961

H. W. TROLANDER
THERMISTOR STANDARDIZING
Filed July 1, 1958

2,970,411

FIG-1

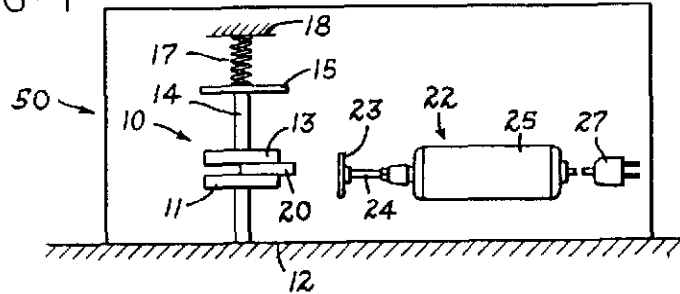

FIG-2

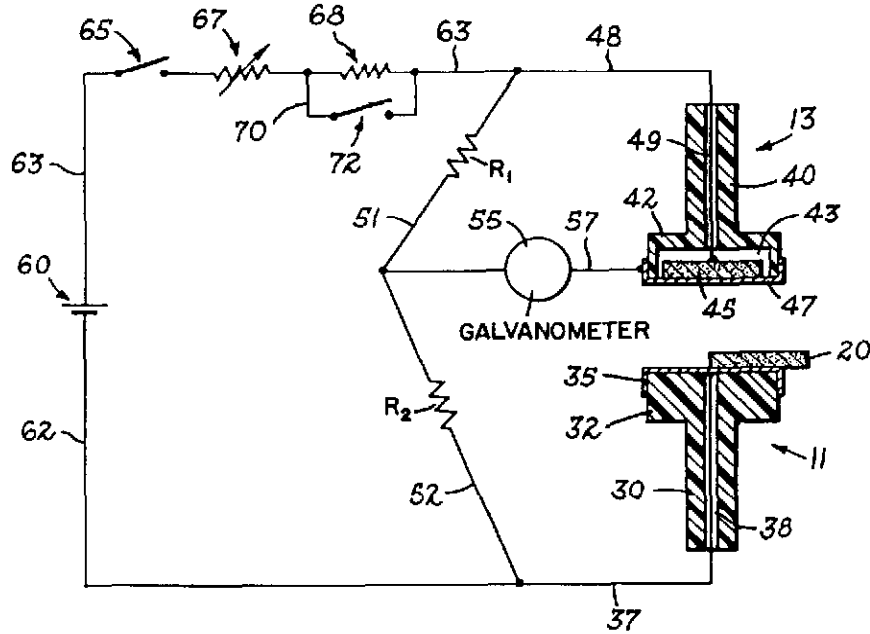

FIGURE 2

The patent on the grinding fixture (first page)

INVENTOR.

HARDY W. TROLANDER

BY

Marshall, Siebel, French & Bugg

ATTORNEYS

Over the following several years YSI developed its production techniques, measurement capability and statistical data base. Working with the NBS (now NIST) the author proposed and then aided the NBS in developing a facility for thermistor measurement. With that facility in place YSI became its first customer by having a group of its thermistor probes measured initially, and then remeasured at scheduled intervals, over many years. This assisted YSI in establishing impeccable stability data for its 400 Series thermistor temperature probes.

Beginning in the 1960s, and led by customer demand, YSI began development of a line of off-the-shelf precision thermistor components in other base values. They were offered in one-three-ten progressions from 100 Ω to 1 meg Ω at 25°C. This line continues in production to this day.

All of these thermistors, like those incorporated into 400 Series probes, are of roughly the same dimensions, and are about 2.5 mm in diameter and 0.25 mm thickness. Manganese and nickel oxides are common to all values, and some of them are doped with other materials, e.g. copper or iron to decrease or increase resistivity. Following forming and sintering, contacts of finely divided silver are fired onto both surfaces of the disc, and it is ready for grinding to its resistance tolerance. After grinding, lead wires are soldered to both flat surfaces, and the disc is coated with epoxy, cured and color coded. In the interests of automation the order of some of the process steps is sometimes changed, but the essential process closely resembles that which YSI developed during the 1950s.

Although thermistors are highly-sensitive resistance thermometers they are non-linear. Many applications require a more linear response over a given temperature span. It had been common to place resistors in series and parallel with them to improve linearity over relatively modest ranges. However this means is not adequate for many applications that would otherwise benefit from the higher sensitivity than that obtained from thermocouples or platinum and nickel resistance thermometers.

In 1966, while driving back to Ohio from a technical exchange at NASA-Greenbelt, the author conceived a network consisting of several thermistors and fixed resistors to obtain a linear output in either ohms or volts vs temperature over a much wider temperature range. The addition of the second active element (the second thermistor) extended the linear range well beyond that which could be achieved from the addition of only passive circuit elements. Linear networks incorporating two or three thermistors then became widely practical because of the availability of YSI's precision thermistors [4, 5]. These networks bear the trade name *THERMILINEAR COMPONENTS*, and went to market in 1967. Fig. 3 (courtesy YSI) illustrates the several forms of these networks and their linear modes

Resistance Mode

Resistance mode operation is achieved by configuring the components as shown in the figures below.

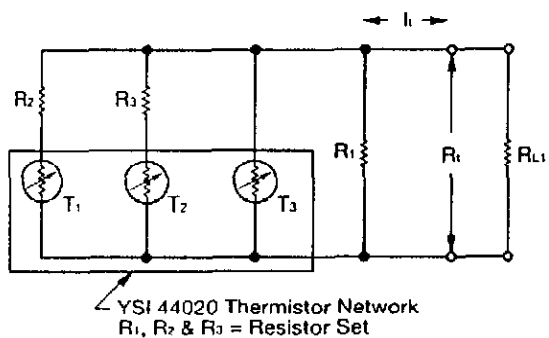
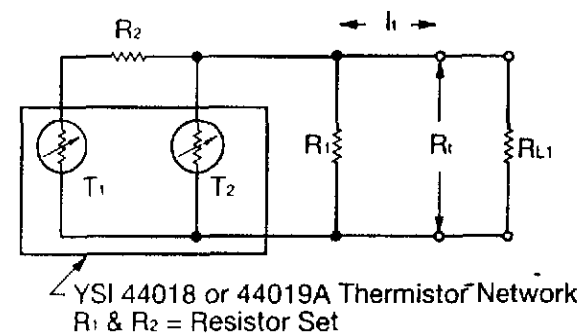

Voltage Mode

Voltage mode operation is achieved by configuring the components as shown in the figures below.

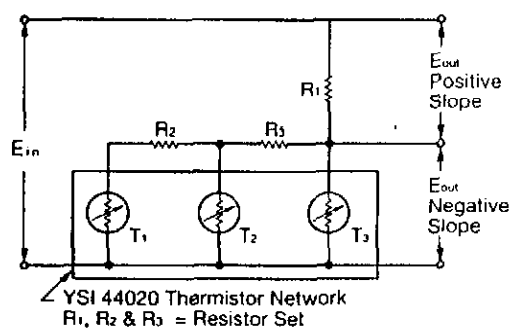
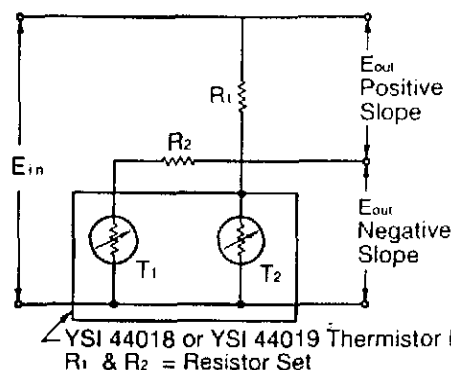

FIGURE 3

Thermilinear networks for linear output in resistance or voltage

in resistance and voltage. They are available in both two- and three-thermistor forms, and cover a number of stock temperature ranges; for example, the YSI 44020 thermistor network covers the range from -50 to +50°C with departure from linearity within $\pm 0.09^\circ\text{C}$.

The exchange with NASA-Greenbelt eventually bore other fruit, for it started a collaboration between NASA and YSI that led to the development in 1974 of a NASA specification for thermistors qualified for extended space flight, and the qualification of certain YSI thermistors under that specification in the same year.

Aging of disc thermistors had been a long-term consideration. Many glass-coated bead thermistors were substantially more stable than epoxy-coated disc thermistors. The change in disc thermistor resistance with time, almost always increasing, was conventionally assigned to an oxygen transport phenomenon. Quite likely that explanation was advanced because epoxy is somewhat permeable to oxygen, and glass is not; that is, it was reasoned backwards.

In 1961 a simple experiment was designed to test that proposition. The author removed 10 thermistors from a much larger production run prior to coating with epoxy. These bare thermistors were divided into two groups. One group was stored at ambient temperature, while the second was outgassed at "high" temperature for several days and then sealed hermetically into glass tubes. The leads extended through the glass, allowing measurement, while within each tube the disc was located far enough from the point of the metal-to-glass seal to avoid exposing the disc to the high sealing temperature. Both groups were measured and stored.

Both groups were measured periodically over several years. The resistance of the bare un-sealed thermistors increased at the same rate as epoxy-coated thermistors - no more, no less. The thermistors sealed into glass tubes aged at exactly the same rate. Was conventional wisdom - the offering of *some* answer to a question - getting in the way, as it often does, of discovering the real answer that Nature waits for us to discover? Of course it was; the data gathered from this simple experiment refuted the conventional wisdom hands-down.

But in the process, new questions that were raised remained unanswered for years. A review of the production processes in manufacture did not turn up any new insights. Could change of an unconventional nature in search of a solution work? As it turned out, you betcha!

In the manufacturing process, following the mixture of constituent powders thermistors are formed into discs that approximate their final dimensions. This forming is done under mechanical pressures on the order of 4000 psi. The discs are

then sintered at temperatures in the vicinity of 1200°C. Following sintering the flat surfaces receive the silver contact medium, which is then bonded to the surfaces at temperatures in the vicinity of 700°C.

Since the thermistor body was formed under pressure, any residual strain might be relieved as a gradual increase in thickness. This would account for an increase in electrical resistance. However one would think that the excursion to sintering temperature for a considerable time, followed by a second excursion to the silver-firing temperature, would have relieved any strain quite completely.

Postulating the measurement of an increase in thickness of the disc equivalent to its increase in electrical resistance was reasonable in theory, but an experiment to prove it was impossible, then, to carry out. Since thickness was on the order of 0.25 mm and an increase of thickness of about 1 part in 1000 would approximate the electrical equivalent of about a year's aging, it became clear that any instrument capable of such a mechanical measurement would need to combine very high resolution with extremely high base-line (point of reference) stability while making measurements over a period of at least a year. Laser measuring devices had not yet become available (they would now be capable of such measurements. It is not so certain that a stable means of mounting the thermistor and the laser would be possible).

But if the aging phenomenon is a function of strain relief, applying and maintaining a means of preserving the strain might result in improved stability. Glass-coated bead thermistors generally displayed better stability than epoxy-coated discs, (although interchangeability tolerances were many degrees: if disc thermistors could be coated with glass, the advantage of grinding to tight tolerances might be preserved). Was the restraining force of the glass, rather than its impermeability to oxygen, responsible for that difference?

To coat a YSI disc thermistor with glass would require a different means of attaching the lead wires, since the temperature needed to fuse the glass into an integral coating would melt the solder attaching the leads. During 1981 a form of thermo-compression bonding was devised and used to attach leads to some experimental thermistors. Glass was then fused around the discs without at the same time soaking the lead wires loose.

Several glass-coated disc thermistors were subjected to accelerated aging tests, and quickly demonstrated superior stability with respect to temperature and time. These were followed by a much larger lot, which was tested over an extended period, and the results showed an order of magnitude better stability compared to epoxy-coated discs. During March, 1982, preliminary results of this de-

velopment were incorporated into a paper presented at the Sixth Annual Symposium on Temperature [6]. Several different component values were also introduced into the market. For more than 10 years these "Super-Stable" thermistors have established themselves as preeminent high-performance tight-tolerance temperature sensors.

In 1961 YSI's line of commercial thermistors defined what remains the state of the art of epoxy-coated thermistors and made practicable the development of thermilinear thermistor networks. Today the state of the thermistor art remains essentially where it was in 1982, although there have been improvements and simplifications in the production processes. Fascinating questions remain. Are glass-coated discs more stable simply because the glass imposes a restraining force to oppose strain relief? Is some other mechanism at work? In any event, the future seems certain to continue to favor thermistors as the highly-sensitive and stable resistance thermometers of choice over their usable ranges and in many applications.

[EDITOR'S NOTE]

Essentially the same technique was applied to perhaps the most stable and precise wire-wound d-c resistance standard ever produced; the Thomas 1- Ω standard resistor, developed by Dr. J. L. Thomas at the NBS. This resistor was made from thick (about 2 mm diameter) manganin wire, and wound to be slightly too low in resistance. Then, after it had been heat-treated and otherwise made very stable, it was brought into tolerance by gently and locally filing away some of the surface of the wire. Tolerances of ± 5 ppm ($\pm 0.00050\%$) were achieved by this simple means. (Measured resistance was given by the manufacturer to 1 part in 10 million at 25°C). A bank of Thomas resistors was the National standards base for the ohm at the NBS and in many other nations, for many decades, until the emergence of the quantum-Hall-effect (*Von Klitzing*) resistance late in this century.

REFERENCES

- [1] L. C. Clark, H. W. Trolander, Thermometer for measuring body temperatures in hypothermia, *Journal of the American Medical Association*, 155 (1954)
- [2] H. W. Trolander, Thermistor Standardizing, U. S. Patent #2,970,411
- [3] H. W. Trolander, Behavior of thermistors at biological temperatures, *IRE Transactions, Biomedical Electronics*, BME-9 (1962)
- [4] H. W. Trolander, R.W. Harruff, A wide-range linear-output thermistor for biological temperatures, 6th annual international conference on medical electronics and biological engineering,

Tokyo (1967)

[5] H. W. Trolander, R. W. Harruff, Extended range thermistor temperature sensing, U. S. Patent #3,316,765

[6] D. A. Case, J. Zurbuchen, H. W. Trolander, Enhanced stability in precision interchangeable thermistors, 6th International symposium on temperature, Washington (1983)

ABOUT THE AUTHORS

HARDY W. TROLANDER is an engineering executive and consultant. After service as an officer in the United States Air Force he received his Bachelor of Science degree from Antioch College in 1947. In 1948 he co-founded the Yellow Springs Instrument Company, and was its President from 1948 to 1986. (He remarked once, at an Employees' meeting, that *he hadn't had a job promotion in thirty-six years!*) He made numerous and important contributions to the understanding and use of precision thermistors as temperature sensors, and his published reports include papers presented at the Fifth and the Sixth Temperature Symposia (TMCSI). From 1976 through 1981 he was a distinguished member of the Evaluation Panel for Absolute Physical Quantities of the National Bureau of Standards. Before and after his retirement, he was (and is) keenly interested in assisting young entrepreneurs in starting and establishing technical business ventures. He has been a Trustee and Chairman of the Board of Antioch College, has served on and chaired numerous Boards of community, social-interest and scientific organizations. He is a member of the National Academy of Engineering. His avocations include the restoration of antique radios and automobiles, and he has a notable collection of his favorite cars, the Chrysler Airflows.