

Model 155
Null Detector-Microvoltmeter
Instruction Manual

Contains Operating and Servicing Information

KEITHLEY

WARRANTY

Keithley Instruments, Inc. warrants this product to be free from defects in material and workmanship for a period of 1 year from date of shipment.

Keithley Instruments, Inc. warrants the following items for 90 days from the date of shipment: probes, cables, rechargeable batteries, diskettes, and documentation.

During the warranty period, we will, at our option, either repair or replace any product that proves to be defective.

To exercise this warranty, write or call your local Keithley representative, or contact Keithley headquarters in Cleveland, Ohio. You will be given prompt assistance and return instructions. Send the product, transportation prepaid, to the indicated service facility. Repairs will be made and the product returned, transportation prepaid. Repaired or replaced products are warranted for the balance of the original warranty period, or at least 90 days.

LIMITATION OF WARRANTY

This warranty does not apply to defects resulting from product modification without Keithley's express written consent, or misuse of any product or part. This warranty also does not apply to fuses, software, non-rechargeable batteries, damage from battery leakage, or problems arising from normal wear or failure to follow instructions.

THIS WARRANTY IS IN LIEU OF ALL OTHER WARRANTIES, EXPRESSED OR IMPLIED, INCLUDING ANY IMPLIED WARRANTY OF MERCHANTABILITY OR FITNESS FOR A PARTICULAR USE. THE REMEDIES PROVIDED HEREIN ARE BUYER'S SOLE AND EXCLUSIVE REMEDIES.

NEITHER KEITHLEY INSTRUMENTS, INC. NOR ANY OF ITS EMPLOYEES SHALL BE LIABLE FOR ANY DIRECT, INDIRECT, SPECIAL, INCIDENTAL OR CONSEQUENTIAL DAMAGES ARISING OUT OF THE USE OF ITS INSTRUMENTS AND SOFTWARE EVEN IF KEITHLEY INSTRUMENTS, INC., HAS BEEN ADVISED IN ADVANCE OF THE POSSIBILITY OF SUCH DAMAGES. SUCH EXCLUDED DAMAGES SHALL INCLUDE, BUT ARE NOT LIMITED TO: COSTS OF REMOVAL AND INSTALLATION, LOSSES SUSTAINED AS THE RESULT OF INJURY TO ANY PERSON, OR DAMAGE TO PROPERTY.



Keithley Instruments, Inc. • 28775 Aurora Road • Cleveland, OH 44139 • 440-248-0400 • Fax: 440-248-6168 • <http://www.keithley.com>

BELGIUM:	Keithley Instruments B.V.	Bergensesteenweg 709 • B-1600 Sint-Pieters-Leeuw • 02/363 00 40 • Fax: 02/363 00 64
CHINA:	Keithley Instruments China	Yuan Chen Xin Building, Room 705 • 12 Yumin Road, Dewai, Madian • Beijing 100029 • 8610-62022886 • Fax: 8610-62022892
FRANCE:	Keithley Instruments Sarl	B.P. 60 • 3, allée des Garays • 91122 Palaiseau Cédex • 01 64 53 20 20 • Fax: 01 60 11 77 26
GERMANY:	Keithley Instruments GmbH	Landsberger Strasse 65 • D-82110 Germering • 089/84 93 07-40 • Fax: 089/84 93 07-34
GREAT BRITAIN:	Keithley Instruments Ltd	The Minster • 58 Portman Road • Reading, Berkshire RG30 1EA • 0118-9 57 56 66 • Fax: 0118-9 59 64 69
INDIA:	Keithley Instruments GmbH	Flat 2B, WILOCRISSA • 14, Rest House Crescent • Bangalore 560 001 • 91-80-509-1320/21 • Fax: 91-80-509-1322
ITALY:	Keithley Instruments s.r.l.	Viale S. Gimignano, 38 • 20146 Milano • 02/48 30 30 08 • Fax: 02/48 30 22 74
NETHERLANDS:	Keithley Instruments B.V.	Postbus 559 • 4200 AN Gorinchem • 0183-635333 • Fax: 0183-630821
SWITZERLAND:	Keithley Instruments SA	Kriesbachstrasse 4 • 8600 Dübendorf • 01-821 94 44 • Fax: 01-820 30 81
TAIWAN:	Keithley Instruments Taiwan	1 Fl. 85 Po Ai Street • Hsinchu, Taiwan, R.O.C. • 886-3572-9077 • Fax: 886-3572-9031

Model 155 Null Detector-Microvoltmeter Instruction Manual

©1976, Keithley Instruments, Inc.
All rights reserved.
Cleveland, Ohio, U.S.A.
Fourth Printing, March 1992
Document Number: 29031 Rev. D

SPECIFICATIONS

RANGE: ± 1 microvolt full scale to ± 1000 volts on zero center meter in 19 overlapping 1X and 3X ranges.

ACCURACY: $\pm 1\%$ of full scale at recorder output, $\pm 2\%$ of full scale at meter, exclusive of noise and drift.

ZERO DRIFT: Less than 0.5 microvolt per 24 hours, typically less than 0.1 microvolt per $^{\circ}\text{C}$. Long-term drift is non-cumulative.

METER NOISE: Less than 0.03 microvolt rms (0.15 microvolt peak-to-peak) on most sensitive range with input *shorted.

INPUT RESISTANCE: 100 megohms—3-volt to 1-kilovolt ranges;
10 megohms—300-millivolt to 1-volt ranges;
1 megohm —1-microvolt to 100-millivolt ranges.

NORMAL MODE REJECTION: An applied 50-60Hz signal which is 80dB greater than full scale peak-to-peak will not affect reading on most sensitive range (equivalent to 100dB NMRR). Rejection decreases to 20dB on the 10 millivolt and higher ranges. Peak AC and DC must never exceed 1200 volts.

COMMON MODE REJECTION: Common mode voltage-DC or 50-60Hz—120dB greater than full scale up to 1200 volts peak will not affect reading (equivalent to 140dB CMRR).

ISOLATION: Greater than 10^{12} ohms shunted by 0.01 microfarad between chassis ground (case) and input low at up to 50% relative humidity and 25°C .

RISE TIME: (10%-90%): 1 second on 10-microvolt range and above, increasing to 5 seconds on 1-microvolt range.

ZERO SUPPRESSION: ± 25 microvolts.

RECORDER OUTPUT: ± 1 volt at up to 1 milliampere.

OVERLOAD: Up to 1200 volts peak may be applied momentarily on any range. Recovery from overload 10^6 times full scale for 1 second with 10-kilohm source is within 5 seconds on the 30-microvolt and higher ranges, increasing to 20 seconds on the 1-microvolt range.

CONNECTORS: Output: Barrier Strip. Input: Binding Posts.

POWER: Four internally mounted carbon-zinc batteries (2N6) provide more than 1000 hours continuous operation. Barrier strip provided for external power supply (+ and -5 volts unregulated).

DIMENSIONS, WEIGHT: Overall bench size $6\frac{1}{2}$ " high \times $8\frac{1}{4}$ " wide \times $7\frac{1}{4}$ " deep (165 \times 210 \times 185mm). Net weight, 6 pounds (2.5kg).

Safety Precautions

The following safety precautions should be observed before using this product and any associated instrumentation. Although some instruments and accessories would normally be used with non-hazardous voltages, there are situations where hazardous conditions may be present.

This product is intended for use by qualified personnel who recognize shock hazards and are familiar with the safety precautions required to avoid possible injury. Read the operating information carefully before using the product.

The types of product users are:

Responsible body is the individual or group responsible for the use and maintenance of equipment, for ensuring that the equipment is operated within its specifications and operating limits, and for ensuring that operators are adequately trained.

Operators use the product for its intended function. They must be trained in electrical safety procedures and proper use of the instrument. They must be protected from electric shock and contact with hazardous live circuits.

Maintenance personnel perform routine procedures on the product to keep it operating, for example, setting the line voltage or replacing consumable materials. Maintenance procedures are described in the manual. The procedures explicitly state if the operator may perform them. Otherwise, they should be performed only by service personnel.

Service personnel are trained to work on live circuits, and perform safe installations and repairs of products. Only properly trained service personnel may perform installation and service procedures.

Exercise extreme caution when a shock hazard is present. Lethal voltage may be present on cable connector jacks or test fixtures. The American National Standards Institute (ANSI) states that a shock hazard exists when voltage levels greater than 30V RMS, 42.4V peak, or 60VDC are present. **A good safety practice is to expect that hazardous voltage is present in any unknown circuit before measuring.**

Users of this product must be protected from electric shock at all times. The responsible body must ensure that users are prevented access and/or insulated from every connection point. In some cases, connections must be exposed to potential human contact. Product users in these circumstances must be trained to protect themselves from the risk of electric shock. If the circuit is capable of operating at or above 1000 volts, **no conductive part of the circuit may be exposed.**

As described in the International Electrotechnical Commission (IEC) Standard IEC 664, digital multimeter measuring circuits (e.g., Keithley Models 175A, 199, 2000, 2001, 2002, and 2010) are Installation Category II. All other instruments' signal terminals are Installation Category I and must not be connected to mains.

Do not connect switching cards directly to unlimited power circuits. They are intended to be used with impedance limited sources. **NEVER** connect switching cards directly to AC mains. When connecting sources to switching cards, install protective devices to limit fault current and voltage to the card.

Before operating an instrument, make sure the line cord is connected to a properly grounded power receptacle. Inspect the connecting cables, test leads, and jumpers for possible wear, cracks, or breaks before each use.

For maximum safety, do not touch the product, test cables, or any other instruments while power is applied to the circuit under test. **ALWAYS** remove power from the entire test system and discharge any capacitors before: connecting or disconnecting cables or jumpers, installing or removing switching cards, or making internal changes, such as installing or removing jumpers.

Do not touch any object that could provide a current path to the common side of the circuit under test or power line (earth) ground. Always make measurements with dry hands while standing on a dry, insulated surface capable of withstanding the voltage being measured.

The instrument and accessories must be used in accordance with its specifications and operating instructions or the safety of the equipment may be impaired.

Do not exceed the maximum signal levels of the instruments and accessories, as defined in the specifications and operating information, and as shown on the instrument or test fixture panels, or switching card.

When fuses are used in a product, replace with same type and rating for continued protection against fire hazard.

Chassis connections must only be used as shield connections for measuring circuits, NOT as safety earth ground connections.

If you are using a test fixture, keep the lid closed while power is applied to the device under test. Safe operation requires the use of a lid interlock.

If a  screw is present, connect it to safety earth ground using the wire recommended in the user documentation.

The  symbol on an instrument indicates that the user should refer to the operating instructions located in the manual.

The  symbol on an instrument shows that it can source or measure 1000 volts or more, including the combined effect of normal and common mode voltages. Use standard safety precautions to avoid personal contact with these voltages.

The **WARNING** heading in a manual explains dangers that might result in personal injury or death. Always read the associated information very carefully before performing the indicated procedure.

The **CAUTION** heading in a manual explains hazards that could damage the instrument. Such damage may invalidate the warranty.

Instrumentation and accessories shall not be connected to humans.

Before performing any maintenance, disconnect the line cord and all test cables.

To maintain protection from electric shock and fire, replacement components in mains circuits, including the power transformer, test leads, and input jacks, must be purchased from Keithley Instruments. Standard fuses, with applicable national safety approvals, may be used if the rating and type are the same. Other components that are not safety related may be purchased from other suppliers as long as they are equivalent to the original component. (Note that selected parts should be purchased only through Keithley Instruments to maintain accuracy and functionality of the product.) If you are unsure about the applicability of a replacement component, call a Keithley Instruments office for information.

To clean an instrument, use a damp cloth or mild, water based cleaner. Clean the exterior of the instrument only. Do not apply cleaner directly to the instrument or allow liquids to enter or spill on the instrument. Products that consist of a circuit board with no case or chassis (e.g., data acquisition board for installation into a computer) should never require cleaning if handled according to instructions. If the board becomes contaminated and operation is affected, the board should be returned to the factory for proper cleaning/servicing.

TABLE OF CONTENTS

Paragraph	Title	Page
SECTION 1-GENERAL INFORMATION		
1.1	Introduction	1-1
1.2	Model 155 Features	1-1
1.3	Warranty Information	1-1
1.4	Manual Addenda	1-1
1.5	Safety Symbols and Terms	1-1
1.6	Safety Precautions	1-2
1.7	Specifications	1-2
1.8	Model 155 Applications	1-2
1.9	Optional Accessories	1-2
SECTION 2-OPERATION		
2.1	Introduction	2-1
2.2	Front Panel Controls	2-1
2.3	Rear Panel Terminals	2-1
2.4	Input Connections	2-1
2.5	Barrier Strip Connections	2-1
2.6	Power Supplies Operation and Connection Check	2-1
2.7	Operating Procedures	2-3
2.8	Floating Operation	2-3
2.9	Recording	2-3
2.10	Accuracy Consideration	2-4
2.11	Noise and Source Resistance	2-4
2.12	Thermal EMFs	2-4
2.13	Shielding	2-4
SECTION 3-THEORY OF OPERATION		
3.1	Introduction	3-1
3.2	Chopper Amplifier	3-1
3.2.1	MOSFET Chopper	3-1
3.2.2	AC Amplifier	3-1
3.2.3	Demodulator	3-2
3.2.4	DC Amplifier	3-2
3.2.5	Total Loop DC Feedback	3-2
3.2.6	Multivibrator	3-2
3.3	Offset Suppression Circuits	3-2
3.4	High Frequency Attenuator Input Filter	3-2
3.5	Input Attenuation	3-2
3.6	Power Supplies	3-2
SECTION 4-SERVICING INFORMATION		
4.1	Introduction	4-1
4.2	Calibration	4-1
4.2.1	Initial Adjustments	4-1
4.2.2	Preliminary Calibration Procedures	4-1
4.2.3	Multivibrator Adjust	4-2
4.2.4	DC Amplifier Balance Adjust	4-3
4.2.5	Offset Current Suppress Calibration	4-3
4.2.6	Meter Calibration	4-3
4.2.7	Accuracy Set Calibration	4-4
4.2.8	Noise Check	4-4

TABLE OF CONTENTS

Paragraph	Title	Page
4.2.9	Rise Time Check	4-4
4.2.10	Overload Recovery Check	4-4
4.2.11	Drift Check	4-4
4.2.12	Range Accuracy Verification	4-5
4.2.13	Normal Model Rejection Check	4-5
4.2.14	Common Model Rejection Check	4-5
4.3	Troubleshooting	4-5
4.3.1	Servicing Schedule	4-5
4.3.2	Preliminary Procedures	4-5
4.3.3	Procedures to Guide Troubleshooting	4-6
SECTION 5-REPLACEABLE PARTS		
5.1	Introduction	5-1
5.2	Parts List	5-1
5.3	Ordering Information	5-1
5.4	Factory Service	5-1
5.5	Special Handling of Static Sensitive Devices	5-1
5.6	Model 155 Schematic Diagram, Dwg. No. 22354E	5-1

LIST OF FIGURES

Figure	Title	Page
2-1	Model 155 Front Panel Controls	2-2
2-2	Model 155 Rear Panel Controls	2-2
3-1	Model 155 Circuit Block Diagram	3-1
4-1	Model 155 Test Points	4-1
4-2	Isolation Test Circuit	4-1
4-3	Multivibrator Output Signal	4-1
4-4	Rise Time Test Circuit	4-4
4-5	Typical 10-90% Rise Time on 100V Range	4-4
4-6	AC Amplifier Circuit Test Points	4-8
4-7	DC Amplifier Circuit Test Points	4-8
5-1	Model 155 Cover Assembly	5-2
5-2	Model 155 Chassis Bottom View	5-2
5-3	Model 155 Schematic Diagram, Dwg. No. 22354E	5-7

LIST OF TABLES

Table	Title	Page
2-1	Battery Check for Power Switch Position	2-3
4-1	Model 155 Recommended Equipment	4-1
4-2	Model 155 Internal Controls	4-2
4-3	Model 155 Test Points	4-2
4-4	Model 155 General Troubleshooting	4-6
5-1	Model 155 Static Sensitive Devices	5-1
5-2	Model 155 Mechanical Parts List	5-3
5-3	Model 155 Electrical Replaceable Parts	5-3

SECTION 1

GENERAL INFORMATION

1.1 INTRODUCTION

The Keithley Model 155 Null Detector-Microvoltmeter is a rugged, solid-state, battery operated instrument. It measures from $1\mu\text{V}$ full scale to 1000V in 19 1X and 3X steps and has 150nV resolution. The recorder output, accurate to 1% of full scale exclusive of noise and drift, extends the versatility of the instrument.

1.2 MODEL 155 FEATURES

1. Excellent immunity to AC interference allows the Model 155 to detect DC signals in the presence of large AC voltages. The Model 155 has greater than 140dB CMRR and 100dB NMRR (refer to specifications that precede this section). Also, hook-up to source is simple and quick. Unshielded leads may generally be used without degrading performance.
2. The Model 155 can recover from 100V overloads within five seconds on the $30\mu\text{V}$ range. Up to 1200V peak may be applied momentarily on any range without damaging the instrument.
3. Stability is better than $0.5\mu\text{V}$ for 24 hours after warm-up with a constant ambient temperature. The long term drift is non-cumulative.
4. The ten turn ZERO control permits easy adjustment of instrument zero. It also provides up to $\pm 25\mu\text{V}$ suppression, which permits measuring of submicrovolts changes in signals up to the limit of the suppression.
5. ZERO CHK position on the power switch allows convenient zeroing of the instrument by shorting the input. This means the measuring circuit need not be disturbed by disconnecting and shorting the input cables.
6. High input resistance of one to $100\text{M}\Omega$ coupled with less than 10^{-11}V per ohm zero shift with source resistance, permits measurement accuracy even with a high resistance source.
7. The Model 155 is designed for battery operation to minimize ground loop and high frequency pick-up problems in sensitive voltage measurements. Four internally mounted carbon zinc batteries provide greater than 1000 hours operation. The Model 155 may also be operated from external supplies. These may be connected to the barrier strip on the rear panel. Power requirement is ± 15 to $\pm 25\text{V}$ at 2mA.
8. Four binding posts on the front panel provide fast and convenient input connection. A $\pm 1\text{V}$ at 1mA output is provided on the rear panel for convenient connection to recorders or other readout devices. Accuracy is $\pm 2\%$ of full scale at the meter and $\pm 1\%$ at the recorder output. A large $4\frac{1}{2}$ inch taut-band meter is provided for ease of readout.

9. The Model 155 is completely solid-state, utilizing a MOSFET chopper in its input circuit. The solid-state chopper requires little power to drive, which gives long battery life and permits the use of inexpensive batteries. It also has low noise and increased sensitivity.
10. All components (except for the meter, battery, input and output connectors) are mounted on a single printed circuit. For calibration or servicing the circuit board may be conveniently and quickly removed from the instrument.
11. Circuit isolation from chassis ground is greater than $10^{12}\Omega$ shunted by $0.01\mu\text{F}$. This high isolation generally eliminates the need for guarding the Model 155.

1.3 WARRANTY INFORMATION

Warranty information may be found inside the front cover of this manual. Should it become necessary to exercise the warranty, contact your nearest Keithley representative or the factory to determine the correct course of action. Keithley Instruments maintains service facilities in the United States, West Germany, Great Britain, France, the Netherlands, Switzerland, and Austria. Information concerning the application, operation, or service of your instrument may be directed to the applications engineer at any of these locations. Check the inside front cover of this manual for addresses.

1.4 MANUAL ADDENDA

Information concerning improvements or changes to the instrument which occur after the printing of this manual will be found on an addendum sheet included with this manual. Be sure to review these changes before attempting to operate or service the instrument.

1.5 SAFETY SYMBOLS AND TERMS

The following safety symbols and terms are used in this manual or found on the Model 155:

The symbol  on the instrument indicates that the user should refer to the operating instructions in this manual.

The symbol  on the instrument indicates that a potential of 1000V or more may be present on the terminal(s). Standard safety precautions should be observed when such dangerous voltages are encountered.

The **WARNING** heading in this manual explains dangers that could result in personal injury or death.

The **CAUTION** heading in this manual explains hazards that could damage the instrument.

1.6 SAFETY PRECAUTIONS

1. This instrument is intended for use by qualified personnel who recognize the shock hazards and are familiar with the safety precautions required to avoid possible injury. Read over the manual carefully before operating this instrument.
2. Exercise extreme caution when a shock hazard is present at the instrument's input. The American National Standards Institute (ANSI) states that a shock hazard exists when voltage levels greater than 30V rms or 42.4V peak are present. A good safety practice is to expect that hazardous voltage is present in any unknown circuit before measuring.
3. Inspect the test leads for possible wear, cracks or breaks before each use. If any defects are found, replace with test leads that have the same measure of safety as those supplied with the instrument.
4. For optimum safety do not touch the test leads or the instrument while power is applied to the circuit under test. Turn the power off and discharge all capacitors, before connecting or disconnecting the instrument.
5. Do not touch any object which could provide a current path to the common side of the circuit under test or power line (earth) ground. Always make measurements with dry hands while standing on a dry, insulated surface, capable of withstanding the voltage being measured.
6. Exercise extreme safety when testing high energy power circuits (AC line or mains, etc). Refer to the operating section.
7. Do not exceed the instrument's maximum allowable input as defined in the specifications and operation section.

1.7 SPECIFICATIONS

Detailed Model 155 specifications may be found immediately preceding this section.

1.8 MODEL 155 APPLICATIONS

1. As a null detector the Model 155 can be used with potentiometers, bridges, ratio devices and comparator circuits.
2. As a microvoltmeter it is ideal for measuring semiconductor resistivity, thermopile and thermocouple potentials, Hall-effect potentials, contact resistances, biologically generated emfs, electrochemical potentials and strain gauge outputs.
3. Other applications include monitoring power supply stability, DTA measurements, resistance thermometry and thermal conductivity measurements.
4. The Model 155 is useful as a general purpose instrument in the research laboratory as well as in electronic development work and process control applications.
5. Its high sensitivity limits the need for expensive potentiometer systems to measure microvolt level signals accurately. It can measure a signal of $30\mu\text{V}$ or less as accurately as some complex potentiometer systems.

1.9 OPTIONAL ACCESSORIES

The following accessories can be used with the Model 155 to provide additional convenience and versatility.

Model 1503 Low Thermal Solder and Flux—The Model 1503 is useful when making connections to low voltage circuits.

Model 262 Low Thermal Voltage Divider—The Model 262 is a precision low thermal divider with divider ratios of $10^2:1$; $10^3:1$, $10^4:1$ and $10^5:1$. The Model 262 is designed to calibrate nanovoltmeters and $1\mu\text{V}$ sensitive DMMS.

SECTION 2 OPERATION

2.1 INTRODUCTION

A layout of the Model 155 front panel controls is contained in Figure 2-1 while Figure 2-2 contains a layout of the rear panel terminals. See the following paragraphs for Model 155 front panel controls and rear panel terminals.

2.2 FRONT PANEL CONTROLS

Power Switch-Turns instrument off, checks zero, sets instrument for normal operation, checks battery condition.

ZERO Control-Allows input zeroing.

+ **Terminal (Input HI)**-Connects input to signal source.

– **Terminal (Input LO)**-Connects input to signal source.

GUARD Terminal-Provides partial guarding for circuitry.

CASE Terminal-Connects instrument case to ground.

RANGE Switch-Selects full scale voltage sensitivity.

2.3 REAR PANEL TERMINALS

GUARD-Provides alternate connection to ground.

OUTPUT HI-Provides output voltage proportional to input voltage between this terminal and OUTPUT LO.

OUTPUT LO-Reference point for output voltage. Common to Input LO. Common tie point for use with external supplies.

+ **POWER INPUT**-Application of positive voltage to this terminal powers instrument circuits.

+ **BATTERY**-Provides direct access to positive voltage from internal battery.

– **POWER INPUT**-Application of negative voltage to this terminal powers instrument circuits.

– **BATTERY**-Provides direct access to negative voltage from internal battery.

2.4 INPUT CONNECTIONS

The Model 155 uses four binding posts on the front panel for all input signal connections.

1. The (+) red and (-) black terminals are the Model 155 input high and low respectively. The voltage to be measured is applied differentially between these two terminals.
2. The blue GUARD terminal is provided for use with guarded potentiometers. When no circuit guard is available, short the GUARD terminal to the (-) terminal.
3. The green CASE terminal provides easy connection to the instrument case. It should normally be tied to earth ground to provide electrostatic shielding for the instrument's circuits.

A. If the signal to be measured is less than 1mV, use copper wires to connect the source to the Model 155 input. This minimizes the error due to thermoelectric voltages (thermal EMF) that may develop due to temperature differences in the measurement circuit.

B. Use shielded input leads when the source resistance is high (above 1k Ω) or when long cables are necessary. Connect the shield to earth ground. Also, shield the source being measured.

C. For low impedance measurements (under 100 Ω) a shielded input cable is usually unnecessary due to the extremely high AC rejection of the Model 155.

2.5 BARRIER STRIP CONNECTIONS

A seven terminal barrier strip connector is mounted on the rear panel. It provides the following:

1. Connections for external power supplies ($\pm 15V$ to $\pm 25V$) to drive the Model 155 circuits.

2. An output voltage related to the signal being measured.

3. An alternate connection to the circuit guard.

A. The rear panel GUARD terminal is electrically identical to the front panel GUARD terminal.

B. The OUTPUT HI and OUTPUT LO terminals provide an output voltage equal to the input voltage divided by the RANGE switch setting. For example: a 15 μV signal being measured on the 30 μV range would produce an output signal of $15\mu V / 30\mu V = 0.5V$. These two terminals may be used for recording the output of the Model 155.

C. The OUTPUT LO terminal is common to the front panel minus (-) terminal which is INPUT LO. However, the OUTPUT LO terminal should not be used as an input connection because the power supply current that flows in the output leads generates a voltage due to the wire resistance.

D. The positive voltage from the internal batteries is connected directly to the positive (+) BATTERY terminal. The negative voltage is connected directly to the negative (-) BATTERY terminal. The common between the positive and negative internal supplies is connected directly to the OUTPUT LO terminal. Power to operate the Model 155 must be applied to the OUTPUT LO, + POWER INPUT and – POWER INPUT terminals. The Model 155 is supplied with barrier strip shorting links to accomplish this function.

2.6 POWER SUPPLIES OPERATION AND CONDITION CHECK

The Model 155 internal circuitry may be powered either by its internal battery supply or by an external supply.



Figure 2-1. Model 155 Front Panel Controls

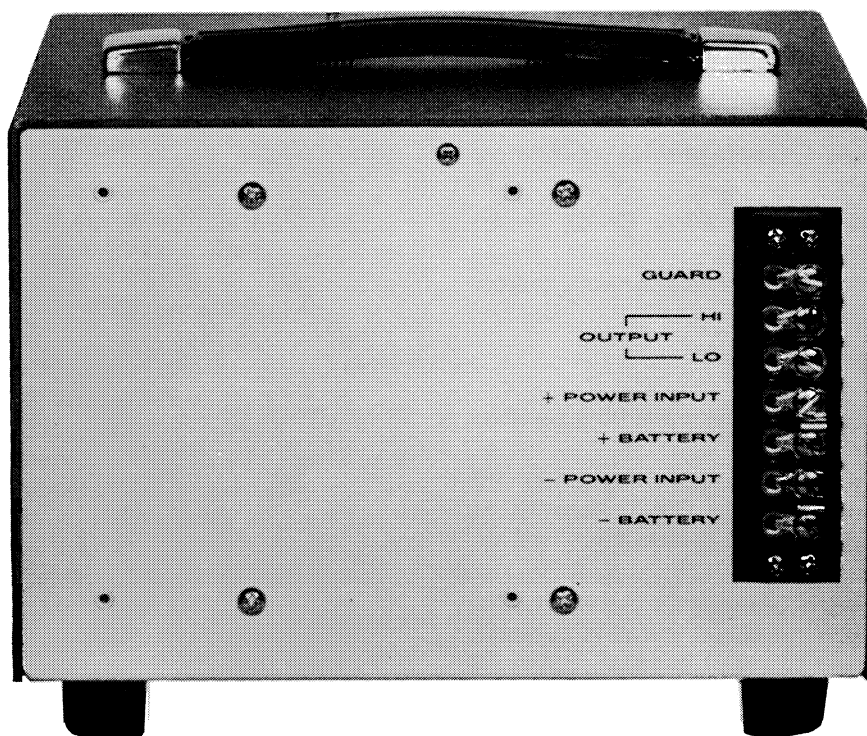

Figure 2-2. Model 155 Rear Panel Terminals

NOTE

Refer to paragraph 2.5 step D for internal electrical connections of the terminals used for power supplies.

1. To power the Model 155 circuits with the internal supply, attach the (+) BATTERY terminal to the (+) POWER INPUT terminal and the (-) BATTERY terminal to the (-) POWER INPUT terminal on the rear panel barrier strip connector with the provided shorting links.
2. To power the circuits with an external supply, attach the positive external supply to the (+) POWER INPUT terminal, the negative external supply to the (-) POWER INPUT terminal and the external supply common to the OUTPUT LO terminal. Make sure that there are no shorting links connected between the (+) and (-) BATTERY terminals and the (+) and (-) POWER INPUT terminals.
3. In order for the Model 155 to function properly the supplies used to power the circuits must be of sufficient strength. To check the state of the supplies (internal or external) set the power switch to the BATT CHK position. Check the positive supply by setting the switch to the (+) position and the negative supply by setting it to the (-) position. In each case the meter needle should deflect to within the green strip on the meter face. If the meter needle does not deflect to within the strip for each supply, that supply is not providing enough power for proper operation.
 - A. If an external supply is being used and the battery check shows a low reading, correct the indicated supply.
 - B. If the Model 155 internal battery supply is being used and the battery check shows a low reading, replace the indicated batteries immediately to prevent corrosion. Table 2-1 shows the internal batteries checked for the (+) and (-) position of the power switch. It is recommended, if the reading in either (+) or (-) position is low, that all of the internal batteries be replaced.
 - C. The battery supplies consist of four disposable carbon zinc batteries (two for the positive supply and two for the negative). The batteries are 9V 2N6 Mallory (246 Eveready) or equivalent. When used continuously, a new battery compliment should provide well over 2000 hours of operation if the recorder output is not used. If the recorder output is used, the batteries will normally provide more than 1000 hours of operation. When the Model 155 is used intermittently the battery life is limited by the shelf life of the batteries.

Table 2-1. Battery Checked for Power Switch Position

Power Switch Position	Batteries Checked
BATT CHK +	BT101
BATT CHK -	BT102

2.7 OPERATING PROCEDURES

1. With the power switch set to OFF, check the meter zero. If necessary, adjust with the meter mechanical zero.
2. Turn the power switch to the BATT CHK position and check the battery condition (see paragraph 2.6 step 3).
3. Set the front panel controls as follows:
Power switch to ZERO CHK.
RANGE switch as necessary.
4. Follow the input connection precautions outlined in paragraph 2-4. Connect the unknown voltage differentially between the (+) and (-) terminals on the front panel. Set the power switch to ON position and increase sensitivity with the RANGE switch, rechecking zero on each range sensitivity increase. Continue to increase sensitivity until the greatest on scale deflection is obtained. Read the voltage as the percentage of full scale that the meter reads times the RANGE switch setting, positive or negative scale.
5. For sensitive measurements, measurements below 10mV, see paragraph 2.11 through 2.13.

2.8 FLOATING OPERATION

The Model 155 may be connected between two potentials, neither of which is at ground. It can be floated up to 1200V off ground.

WARNING

Do not touch the measurement circuit when floating the instrument off ground. Hazardous voltage may be present between earth ground and the floating terminal. The American National Standards Institute (ANSI) states that a shock hazard exists when voltage levels greater than 30V rms or 42.4V peak are present.

CAUTION

Do not exceed the instrument's maximum allowable inputs as defined in the specifications. Otherwise instrument damage may occur.

The Model 155 is excellent for measuring signals off ground because of the extremely high resistance between the input terminals and the case. However, the $10^{12}\Omega$ isolation specification can be maintained only as long as the front panel binding posts and the area around the barrier strip connector are kept clean.

Except for the above outlined precautions, operation for the Model 155 in floating configuration is the same as outlined in paragraph 2-7.

2.9 RECORDING

The Model 155 has an output of $\pm 1V$ at up to $\pm 1mA$ for recording. It can be used directly with 1V and 1mA recorders. If the Model 155 is used for floating measurements, the recorder must also be floating.

To record the Model 155 output connect the OUTPUT HI and OUTPUT LO terminals on the barrier strip connector to the respective input high and low terminals on the recorder. Adjust the recorder sensitivity and zero as desired.

NOTE

The actual isolation of the recording system is the parallel combination of the isolation of the Model 155 and the recorder. Thus, the $10^{12}\Omega$ isolation of the Model 155 may be compromised by the recorder low-to-ground isolation.

2.10 ACCURACY CONSIDERATIONS

For sensitive measurements, other external considerations besides the Model 155 will affect the accuracy. Effects not noticeable when working with higher voltages are very important with microvolt signals. The Model 155 reads only the signal received at its input; therefore, it is important that this signal be properly transmitted from the source. The following paragraphs indicate factors which affect accuracy, noise, source resistance, thermal emfs and stray pick-up.

2.11 NOISE AND SOURCE RESISTANCE

The limit of resolution in measuring voltages with the Model 155 is determined by the noise present. The input noise of the Model 155 is 150nV peak-to-peak. This noise is inherent in the Model 155 itself and will be the minimum amount present in all measurements. The 150nV of noise is due to the instrument's voltage noise. The noise at the Model 155 input increases beyond this minimum when the noise current passes through a source resistor and thereby generates a voltage noise. Thus the total noise becomes a function of the source resistance and is given by the equation

$$n^2 = e_n + (i_n R_S)^2 \quad \text{equation 1.}$$

where n is the total input noise,

e_n is the input voltage noise of the Model 155,

i_n is the input current noise,

R_S is the parallel combination of source resistance and input impedance.

Even on the most sensitive range, the noise due to the current is not appreciable until R_S reaches approximately 10k Ω . Thus, for an R_S of zero ohms to 10k Ω the noise at the input is effectively the inherent 150nV peak-to-peak. Beyond 10k Ω the noise due to R_S becomes evident and a limiting factor in the measurement. Therefore, it is recommended that for sensitive measurements R_S be kept relatively low, if possible, below 10k Ω .

The input impedance of the Model 155 is at least 1M Ω as long as the instrument amplifiers are not saturated, i.e., as long as the meter needle is on scale. On higher ranges it is even greater (see specifications). Therefore, the Model 155 can

measure signals with a large amount of source resistance on the input without degrading performance. Note, however, that if the source resistance is high, the signal seen at the input of the Model 155 will be reduced by the voltage division between the source resistance and the Model 155 input resistance.

2.12 THERMAL EMFS

Thermal emfs (thermoelectric potentials) are generated by thermal differences between two junctions of dissimilar metals. These can be large compared to the signal which the Model 155 can measure. Thermal emfs can cause the following problems:

1. Instability or zero offset much higher than expected.
2. The instrument is sensitive to and responds to temperature changes. This is seen by touching the circuit, by putting a heat source near the circuit, or by a regular pattern of instability, corresponding to heating and airconditioning systems or changes in sunlight.
3. To minimize the drift caused by thermal emfs use copper leads to connect the circuit to the Model 155. The input terminals of the Model 155 are of a copper alloy, using the same metal or metals having the same thermoelectric power as the input will result in minimal generation of thermal emfs. The leads to the input may be shielded or unshielded, as necessary (see paragraph 2.13).
4. Widely varying temperatures within the circuit can also create thermal emfs. Therefore, maintain constant temperatures to minimize these thermal emfs.
5. The ZERO control can be used to buck out constant offset voltages.

2.13 SHIELDING

The Model 155 is insensitive to AC voltages superimposed upon a DC signal at the input terminals. However, AC voltages which are extremely large compared with the DC signal may erroneously produce a DC output. Therefore, if there is AC interference, the circuit should be shielded and the shield connected to the Model 155 ground, particularly for low-level sources. Improper shielding can cause the Model 155 to reach in one or more of the following ways:

1. Unexpected offset voltages.
2. Inconsistent readings between ranges.

To minimize pickup, keep the voltage source and the Model 155 away from strong AC magnetic sources. The voltage induced due to magnetic flux is proportional to the area of the loop formed by the input leads. Therefore, minimize the loop area of the input leads and connect each shield at only one point.

SECTION 3 THEORY OF OPERATION

3.1 INTRODUCTION

The Keithley Model 155 is composed of a variable gain chopper amplifier, an offset voltage suppression circuit, an AC attenuator filter, input attenuators, an output monitoring circuit and power supplies (See Figure 3-1).

The main signal flow path is as follows: An input signal is applied through the power switch where it is divided to a determined ratio by the RANGE switch resistors. A MOSFET chopper converts this DC input signal to an AC signal. The AC signal is amplified, demodulated, DC amplified and applied to the meter and the output. A feedback network samples the signal at the output and compares it to the input. The DC input signal and the feedback signal are compared at the input of the chopper. The AC amplifier amplifies the difference signal. The AC signal is then demodulated and enters a DC amplifier. The DC amplifier output is connected to the meter, the output terminals and the feedback network. The feedback resistors determine full scale range. The feedback resistors determine full scale range.

The power source for the Model 155 is derived from disposable batteries.

NOTE

The circuit designations referred to in this section are for schematic diagram 22354E found at the end of the manual.

3.2 CHOPPER AMPLIFIER

The chopper amplifier consists of a chopper (sometimes called a modulator) which switches the input DC signal on and off to produce an AC output. This AC is then amplified and demodulated to regain the DC signal. Further amplification is then achieved with a DC amplifier. The negative feedback is employed around the total amplifier to achieve gain accuracy and gain stability. Synchronous demodulation is obtained by synchronizing the demodulating switch with the chopper. The individual circuits in the chopper amplifier are described as follows:

3.2.1 MOSFET Chopper

The field-effect transistor when used as a chopping device provides low offset currents, low offset voltages, low noise and low drive power. A series shunt chopping configuration provides low noise and high input impedance.

Transistors Q101 and Q102 are the chopper. Resistor R184 and capacitor C104 are used to minimize the problem of the chopper drive feeding into the signal channel.

3.2.2 AC Amplifier

The AC amplifier is composed of a low noise amplifier and a variable gain amplifier.

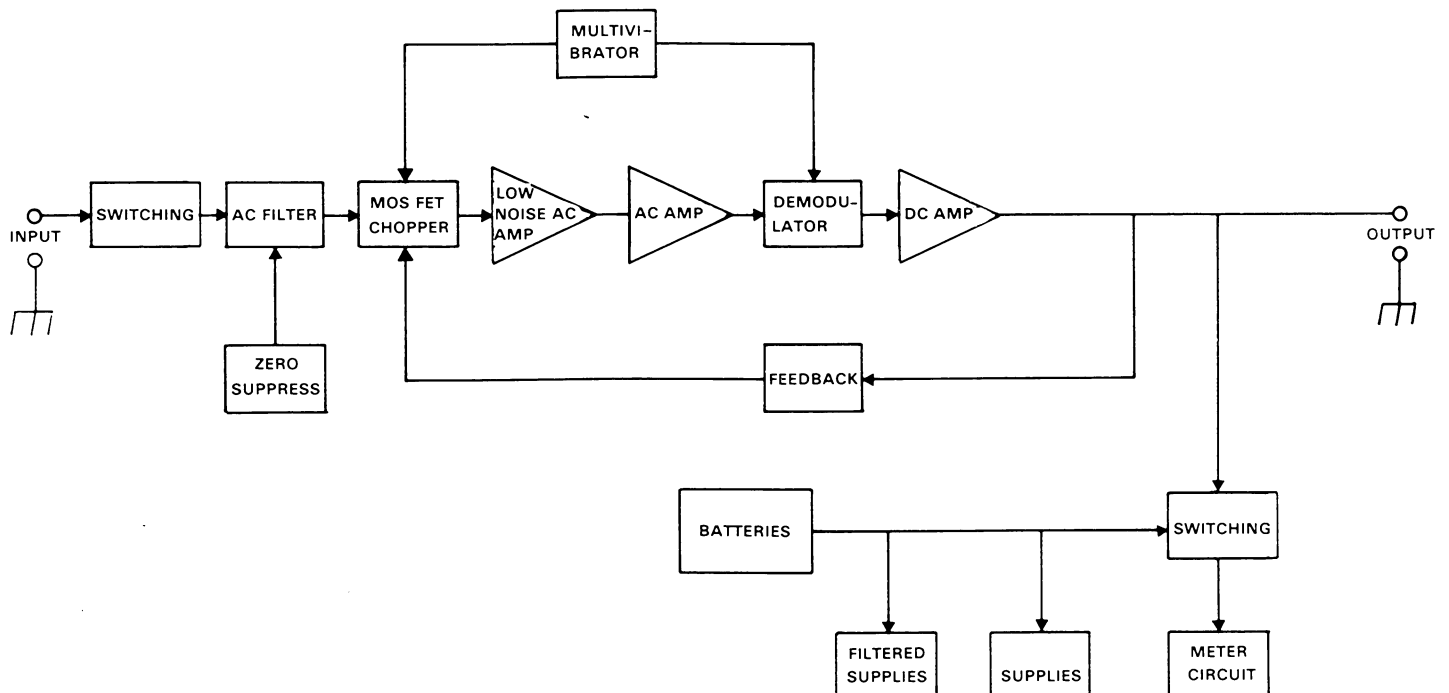

Figure 3-1. Model 155 Circuit Block Diagram

A bi-polar transistor, Q103, biased for operation at low current levels, is the input device. Transistors Q103, Q104 and associated components, are a low noise amplifier with a gain of 34, as fixed by the feedback resistors R129 and R131.

The low noise amplifier is followed by a variable gain AC amplifier consisting of transistors Q105, Q106, Q107 and associated components. It is necessary to have high gain when measuring very low voltages, and less gain when the total chopper amplifier is to be used at lower gain to prevent oscillations. For this reason, the gain of the second amplifier is varied by switching the feedback resistor. Resistor R147 and R148 along with capacitor C128 provide a high frequency cut off for the attenuation of the spikes generated in the chopper by the chopper drive.

3.2.3 Demodulator

Field-effect transistor Q118 acts as a switch which is synchronized with the input chopper and thus provides synchronous demodulation. The average value of the signal obtained at the junction of capacitor C112 and resistor R149 is proportional to the DC input signal. Because of the switching action of Q118, the signal at this junction is shorted to ground for half of each chopping cycle. Consequently, this DC signal has a large chopper frequency component.

3.2.4 DC Amplifier

The function of this amplifier is twofold: It gives additional amplification to the relatively small signal seen at the output of the demodulator; and it integrates the output of the demodulator, thus removing most of the chopper frequency ripple which appears there. Direct coupled output is used for the amplifier to meet the requirements of providing 1mA of output current.

The DC amplifier is composed of three differential amplifiers and an emitter follower. The signal from the output of the demodulator is applied to the first differential DC amplifier, composed of transistors Q116, Q108 and amplified. The second amplifier, transistors Q109 and Q110, amplifies the output signal from the first amplifier and applies it to a third differential amplifier, Q111 and Q112, for further amplification. Emitter followers Q113, Q114 and Q115 are an impedance changing circuit to provide low output impedance.

3.2.5 Total Loop DC Feedback

The Model 155 uses negative feedback to achieve gain accuracy and stability and assures high input impedance. The resistors are switched into the feedback current in such a way as to maintain low feedback current and avoid excessively high value resistors in the feedback loop.

The feedback network, composed of resistors R118 through R185, is formed from the output of the DC amplifier to the input of the chopper amplifier. The RANGE switch, S101, selects the feedback ratio used for each range.

3.2.6 Multivibrator

The multivibrator circuit generates the drive voltage for the chopper and demodulator.

Transistors Q120 through Q123 and their associated components are an astable multivibrator. Output voltages are taken at the emitters of Q120 and Q123. These output voltages are opposite phase square waves and are used directly as the chopper drive. The output at the emitter of Q120 is also used as the demodulator drive.

3.3 OFFSET SUPPRESSION CIRCUITS

When measuring signals in the microvolt region it is often desirable to suppress the zero voltage level so that small changes may be readily observed. For this reason a front panel ZERO control, R173, is provided. This control is non-linear so that for normal operation (suppression of less than $\pm 5\mu V$) accurate zeroing may be easily achieved, while still having available suppression of at least $\pm 25\mu V$.

Offset current is suppressed by the circuit consisting of potentiometer R104 and resistors R110 and R186.

3.4 HIGH FREQUENCY ATTENUATOR INPUT FILTER

The frequency attenuating filter at the input of the Model 155 provides approximately 50dB of AC rejection at 60Hz. The filter is a 3-section RC ladder filter consisting of resistors R107, R108, R111, R112, and capacitors C101, C102 and C103.

3.5 INPUT ATTENUATION

The chopper amplifier has a minimum gain of 100 and a maximum output voltage of $\pm 1V$. This means it is necessary to attenuate signals larger than 10mV to prevent saturation of the chopper amplifier. The input attenuator resistors R102 through R106 and R113 through R117, are switched by the RANGE switch, S101. One decade of attenuation is necessary to handle signals as high as 100mV. Two decades of attenuation are necessary to handle signals as large as 1V. Input attenuation is switched in a decade at a time, and the gain of the chopper amplifier is altered between 333 and 100 for all ranges above 10mV.

Because of potential instability in the resistance value of high value resistors, potentiometers have been placed in the attenuator string. Thus, the instrument can be accurately calibrated even if the high value resistors drift.

3.6 POWER SUPPLIES

Power for the Model 155 is provided by four 9V carbon zinc batteries. The idling current of the Model 155 is approximately $500\mu A$. Thus the battery life for most applications will be the same as the battery life. If the recorder output is used, a maximum of 1mA may be drawn from it, so the battery life will still be normally in excess of 1000 hours.

Because the battery noise may increase and terminal voltage will decrease with battery age, and because it is necessary to have fixed voltage for the offset suppression circuits, zener supplies consisting of transistors D106, D107 and associated

components provide a regulated $\pm 6V$. The low noise amplifier supplies are isolated from the other supplies by filters consisting of resistors R167 and R168 and capacitors C116 and C117.

SECTION 4 SERVICING INFORMATION

4.1 INTRODUCTION

This section contains information necessary to maintain, calibrate and troubleshoot the Model 155.

WARNING

The procedures described in this section are for use only by qualified service personnel. Do not perform these procedures unless qualified to do so. Many of the steps covered in this section may expose the individual to potentially lethal voltages that could result in injury or death if normal safety precautions are not observed.

4.2 CALIBRATION

The following procedures are recommended for calibrating and adjusting the Model 155. Use the equipment in Table 4-1. If proper facilities are not available or if difficulty is encountered, contact the nearest Keithley Instruments representative in your area to arrange for factory calibration.

If the Model 155 is not within specifications after calibration, refer to the troubleshooting procedures which follow.

NOTE

Figure 4-1 shows the location of internal test points used in calibrating the Model 155. Table 4-2 lists Model 155 internal controls.

4.2.1 Initial Adjustments

1. Set the Model 155 power switch to OFF and RANGE switch to 1000V.
2. Check the barrier strip connector on the rear panel of the Model 155. Make sure that shorting links are placed between the (+) POWER SUPPLY and (+) BATTERY terminals.
3. Verify the input LO (-) to CASE isolation is greater than $10^{12}\Omega$ with the following procedure.
 - A. Set up the circuit in Figure 4-2.
 - B. Set the Model 155 to the 1000V range and OFF.
 - C. Set the Model 480 to ON and the 10nA range.
 - D. Program the Model 230 to output 100V.
 - E. The reading on the Model 480 should be less than 100pA (<0.10 on the 10nA range).
 - F. Using Ohm's law calculate the isolation. For example:
 $R = E/I = 100V/100pA = 10^{12}\Omega$.
4. Adjust the Model 155 meter for zero with the mechanical zero.
5. Check the battery condition by setting the power switch to BATT CHK (+) and (-) positions. For each polarity the meter needle should indicate 70% to 100% of full scale (green area). New batteries typically indicate greater than 86% of full scale (18.5V or more). After checking battery condition, set the power switch to OFF.

NOTE

See paragraph 2-6 also for checking the condition of the batteries.

4.2.2 Preliminary Calibration Procedures

1. Make sure that offset current suppress potentiometer, R109, is at least one turn from either end. Short R186 with a jumper wire. Do not remove this short until specifically stated in paragraph 4.2.5.
2. Turn the power switch to ZERO CHK. Within a few moments the meter needle should come to zero indication. If necessary, zero the meter with the ZERO control. Increase the Model 155 sensitivity to $100\mu V$ and zero the meter.
3. If the Model 155 is inoperative, that is, if the meter pins, check the voltage at the test points given in Table 4-3 to the values indicated. If these voltages are found satisfactory, check the multivibrator (see paragraph 4.2.3). If all the above checks are satisfactory, localize the trouble to the AC or DC section of the amplifier by shorting the demodulator test point (test point 10, Figure 4-1) to low

Table 4-1. Model 155 Recommended Equipment Test

Description	Specification	Mfg.	Model
DMM		Keithley	195
Picoammeter	10^{-10} Amps Sensitivity	Keithley	480
Voltage Source	100V	Keithley	230
Frequency Counter	—	H-P	5315A
DC Calibrator	100mV, 1V ($\pm .002\%$)	Fluke	343A
Low Thermal Voltage Divider	10^5 to 1, 10^3 to 1 division ratio	Keithley	262
Chart Recorder	1V/inch	H-P	7035B
Oscilloscope	—	Tektronix	465
Low Thermal Cable	Low Thermal	Keithley	1507

and adjusting DC amplifier balance potentiometer, R151, from one end to the other. If potentiometer R151 can swing the meter full scale from (+) to (-) and vice versa, the problem is in the AC section of the amplifier. If it cannot, the problem is in the DC section. (Refer to the troubleshooting procedures 4-3).

Table 4-2. Model 155 Internal Controls

Control	Circuit Desig.
Accuracy Set	R101
Accuracy Set	R104
Offset Current Suppress	R109
DC Amplifier Balance	R151
Multivibrator Frequency Set	R178
Meter Calibrate	R183

Refer to Figure 4-1.

Table 4-3. Model 155 Test Points

Test Point	Voltage
1	approximately - 16.2 volts
2	approximately + 16.2 volts
3	approximately + 14.9 volts
4	approximately - 14.9 volts
5	+6V ±2V
6	-6V ±2V

4.2.3 Multivibrator Adjust

Connect the Model 5315A frequency counter between the multivibrator test point (point 7 and 8, Figure 4-1). Adjust the multivibrator frequency set potentiometer, R178, for a reading of 220Hz ±3Hz.

Connect the oscilloscope between test points 7, 8 and low, and observe the waveform. The oscilloscope should be set at 2V per division vertical and at a 1msec sweep. The wave form should be near symmetrical 7 to 12V peak-to-peak square wave (see Figure 4-3).

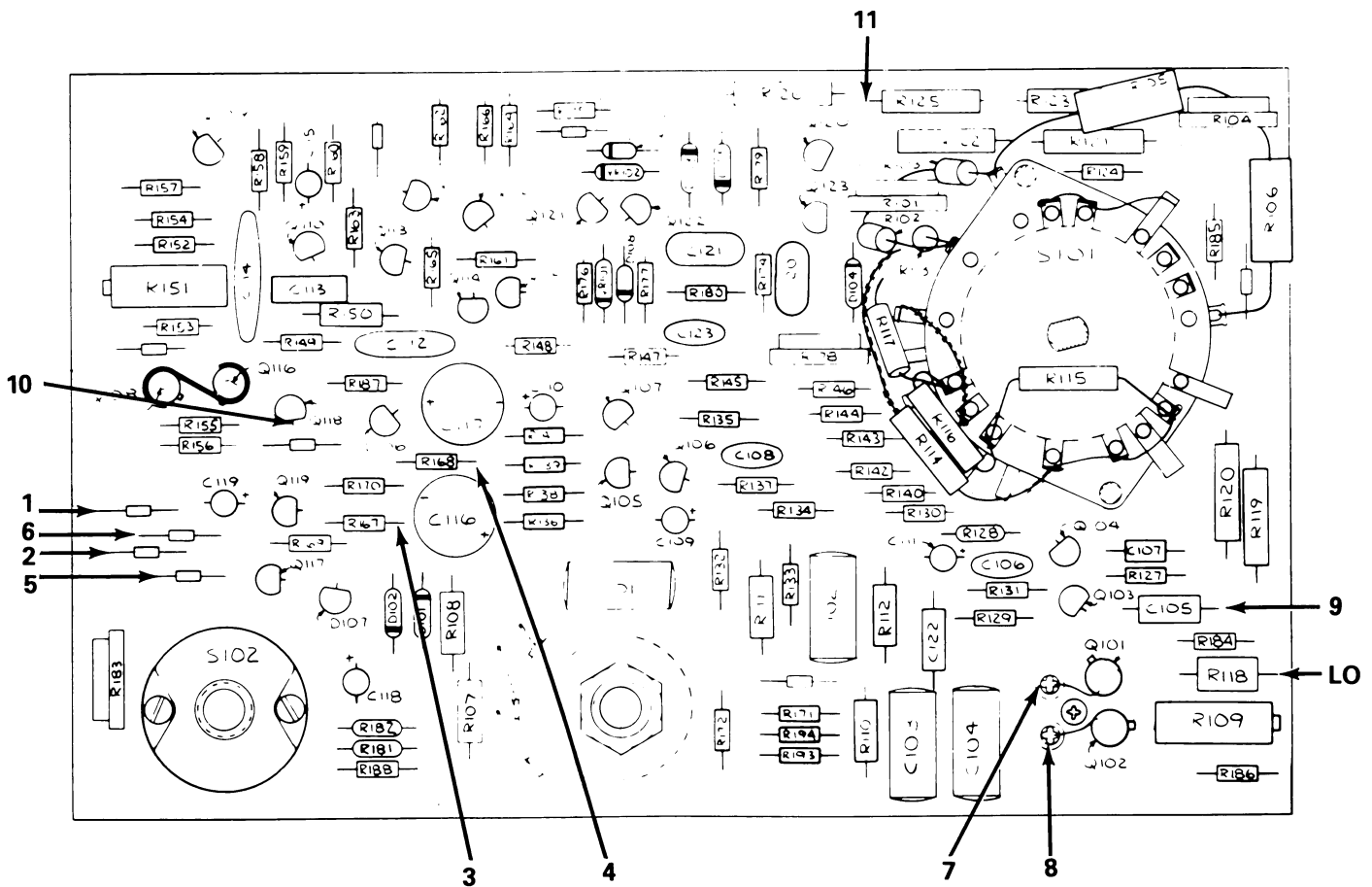

Figure 4-1. Model 155 Test Points

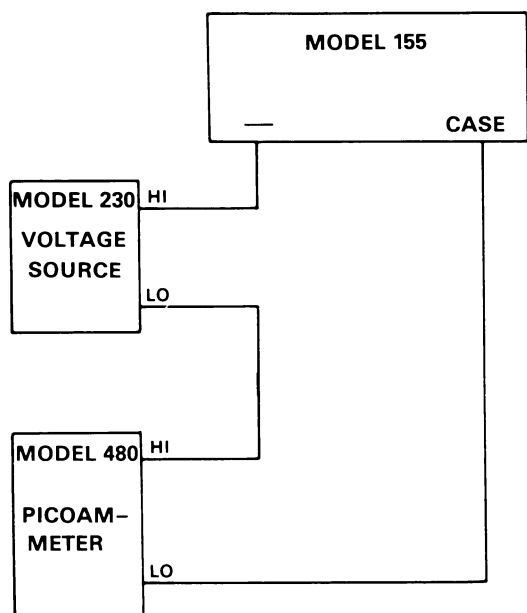

Figure 4-2. Isolation Test Circuit

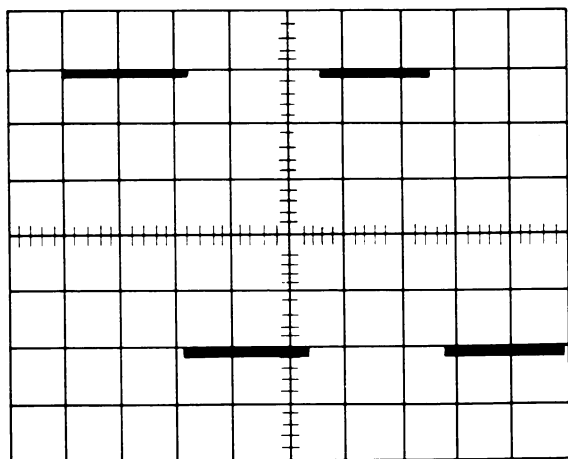

Figure 4-3. Multivibrator Output Signal

4.2.4 DC Amplifier Balance Adjust

1. Connect the Model 155 output to the Model 195 DMM. Set the Model 155 power switch to ZERO CHK and read zero from the 20mV range.
 - A. Set the Model 155 RANGE switch to 10 μ V and adjust the ZERO control for 0 ± 2 mV at the output exclusive of noise. (Typical noise is from 2 to 5mV peak-to-peak.)
 - B. Set the RANGE switch to 1000V and adjust the DC amplifier balance potentiometer, R151, for 0 ± 0.5 mV at the output.
2. Once adjusted, step the RANGE switch from 100V through 1000V. Large zero shifts (8mV or more) between ranges generally indicates that input FETs Q101 and Q102 may be defective.

4.2.5 Offset Current Suppress Calibration

NOTE

Make sure the Model 155 cover is on during this test procedure. Diodes D101 through D105 may be sensitive to light and the adjustment is void without the cover on.

1. Remove the short from R186 and disconnect the Model 195.
2. Shield the Model 155 input. (The input may be shielded by affixing banana plugs inside a metal case and covering the four front panel binding posts with the case, being careful to insert the banana plugs into the GUARD and CASE terminals). Shielding is necessary to reduce pick-up.
3. Set the Model 155 power switch to ZERO CHK and the RANGE switch to 100 μ V.
 - A. Adjust the ZERO control for zero meter indication.
 - B. Open the input by setting the power switch to ON and adjust the offset current suppress potentiometer, R109, for near zero meter indication.
4. Set the power switch to ZERO CHK and the RANGE switch to 30 μ V.
 - A. Adjust the ZERO control for zero meter indication.
 - B. Set the power switch to ON and adjust potentiometer R109 for less than a $\pm 5\mu$ V shift (0 ± 5 minor divisions on the lower meter scale).
 - C. If necessary, repeat steps 1 and 2 to obtain less than 5 μ V shift on the meter when switching the power switch between ZERO CHK and ON positions.
5. With the power switch set to ON step the RANGE switch from 30 μ V to 1V. Offset on the 100 and 300 μ V ranges should be less than 5 μ V decreasing to a negligible offset on the 1mV through 1V ranges.

4.2.6 Meter Calibration

1. Connect the Model 230 to the Model 155 input and connect the output to the Model 195 DMM.
2. Set the Model 155 RANGE switch to 1V and apply ± 1 V to the input with the Model 230.
 - A. Adjust the ZERO control and/or the input voltage to obtain a +1.000V at the output.
 - B. Adjust the meter calibrate potentiometer, R183, for a full scale positive deflection on the Model 155 meter scale.
3. Apply -1V to the Model 155 input and adjust the ZERO control and/or the input voltage to obtain -1.000V at the output.
 - A. Note the negative full scale meter deflection.
 - B. If necessary, adjust potentiometer R183 to split the difference between positive and negative full scale deflections.
4. Typical positive and negative full scale error is less than 1% (1/2 minor division).

4.2.7 Accuracy Set Calibration

1. Keep the Model 155 connected as in paragraph 4.2.6.
2. Set the RANGE switch to 1V and the power switch to ZERO CHK.
 - A. Adjust the ZERO control for 0.000V at the output.
 - B. Apply 1.000V to the input and adjust accuracy set potentiometer, R101, for 1.000V at the output.
3. Set the RANGE switch to 10V and the power switch to ZERO CHK.
 - A. Adjust the ZERO control for 0.000V at the output.
 - B. Apply 10.000V to the input and adjust accuracy set potentiometer, R104, for 10.00V at the output.

NOTE

Always adjust potentiometer R101 before potentiometer R104 because R101 affects R104.

4.2.8 Noise Check

NOTE

Keep Model 155 cover on to minimize noise pick-up.

1. Set the Model 155 power switch to ZERO CHK and the RANGE switch to $1\mu\text{V}$. Zero the instrument with the ZERO control. After zeroing, observe the meter noise for less than 150nV peak-to-peak (7 minor divisions on the upper meter scale). Observe the meter for a period of 15 seconds.
2. Observe the meter noise in the same manner on the $3\mu\text{V}$ and $100\mu\text{V}$ ranges. The noise on the $3\mu\text{V}$ range should be approximately the same as that on the $1\mu\text{V}$ range decreasing the same as that on the $1\mu\text{V}$ range decreasing to less than 1% (1/2 division on the upper meter scale) on the $100\mu\text{V}$ range.

4.2.9 Rise Time Check

NOTE

Keep Model 155 cover on to minimize noise pick-up.

1. Set up the test circuit shown in Figure 4-4.
2. Set the Model 155 RANGE switch to $1\mu\text{V}$ and the power switch to ON. Set the Model 262 to divide the input voltage by 10^5 .
 - A. Zero the Model 155 with the front panel ZERO control. Set the DC calibrator to output +100mV. The output of the Model 262 should be +1 μV (0.000001V). As the DC calibrator is set to output 100mV observe the Model 155 10% to 90% rise time on the meter. This rise time must be less than five seconds and typically it is less than three seconds.

NOTE

Refer to the Model 262 instruction manual for proper operation of the instrument.

- B. Repeat the previous step with a negative signal.
3. Set the Model 155 RANGE switch to $100\mu\text{V}$ and the power switch to ON. Set the Model 262 to divide the input signal by 10^4 .
 - A. Zero the Model 155 with the front panel ZERO control.
 - B. Set the DC calibrator to output +1V. The output of the Model 262 should be +100 μV . As the DC calibrator is set to output 1V observe the Model 155 10-90% rise time on the oscilloscope. The rise time must be less than one second and typically is less than 0.5 seconds. Figure 4-5 shows a typical rise time of the Model 155 on the 100V range.

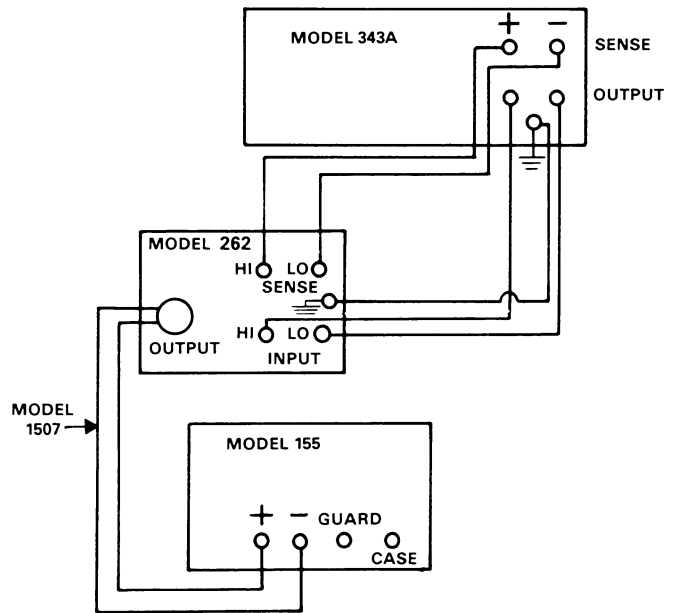

Figure 4-4. Rise Time Test Circuit

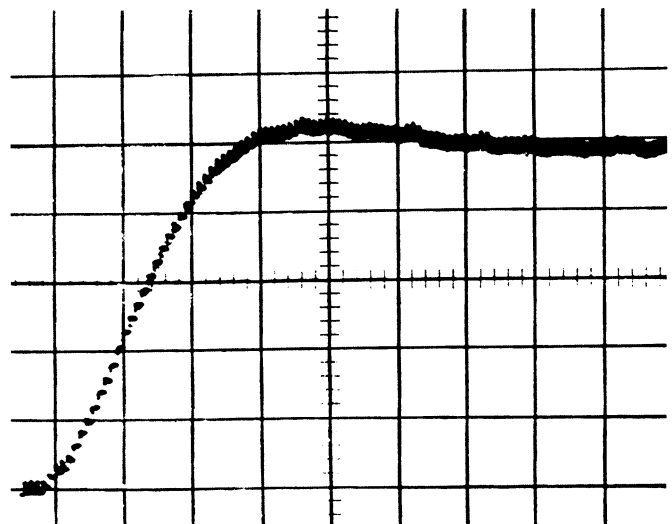

Figure 4-5. Typical 10-90% Rise Time on 100V Range

4.2.10 Overload Recovery Check

1. Place a 10k Ω resistor across the Model 155 input.
2. Set the Model 155 RANGE switch to 30 μ V and the power switch to ON. Zero the meter with the ZERO control.
3. Connect the common lead of a Model 230 to the LO (-) terminal of the Model 155. Program the Model 230 to output +30V. Connect the HI terminal of the Model 230 to the HI (+) terminal of the Model 155 for approximately one second. The Model 155 should recover from this overload within five seconds.
4. Set the RANGE switch to 1 μ V and zero the meter. Apply 1V to the Model 155 in the same manner as in step 3. The Model 155 should recover from this overload within 20 seconds.
5. Remove the 10k Ω resistor from the Model 155 input.

4.2.11 Drift Check

1. Connect the Model 7035B recorder to the Model 155. Set the Model 155 RANGE switch to 1 μ V and the recorder attenuator to 1 μ V. Recorder calibration is now 1V full scale.
2. After a half hour warm-up, zero the instrument again. Using zero as a reference, the Model 155 must not drift more than 0.5 μ V either side of zero in 24 hours. (In that 24 hour span the instrument will drift about the zero reference but should never deviate more than 0.5V from reference).

4.2.12 Range Accuracy Verification

1. Check the 1000V through 100 μ V ranges for 1V \pm 1% at the Model 155 output and \pm 2% of full scale (1 minor upper scale division) on the meter. Check the 30 μ V through 1 μ V ranges for \pm 2% of full scale exclusive of noise and drift.
 - A. To check the 1000V through 3V ranges use the Model 343A to apply voltages to the Model 155 input. Monitor the output with the Model 195 DMM.
 - B. To check the 1V through 1 μ V ranges, use the Model 343A and Model 262 to apply the voltage to the Model 155 input. Monitor the output on the 1V through 100 μ V ranges with the Model 195.
 - C. Check the 1000V and 10 μ V ranges for both positive and negative polarity. All other ranges may be checked using only one polarity.
2. If necessary, adjust the accuracy set potentiometer, R104, to bring in all ranges from 3V to 1000V within tolerance. Also, the accuracy set potentiometer, R101, may be adjusted to bring the 300mV and 1V ranges within tolerance. Note, however, that re-adjusting potentiometer R101 will require rechecking the 3V through 1000V ranges (refer to note in paragraph 4.2.7).

4.2.13 Normal Mode Rejection Check

1. Set the Model 155 power switch to ZERO CHK.
2. Set up the rejection check equipment as follows: apply a

signal from the Model 3310A function generator through a 5 μ F capacitor to the Model 262 set to divide by 10³ and connect the divider output to the Model 155 input. Connect the Model 155 (-) low, GUARD and CASE terminals together. Monitor the function generator with an oscilloscope.

3. Set the function generator frequency to 50Hz and the output to minimum.
 - A. Set the Model 155 power switch to ON, RANGE switch to 1 μ V and zero the Model 155 with the ZERO control. Due to thermals on the input, it should require approximately one minute for the instrument to stabilize.
 - B. Increase the function generator output to 10V peak-to-peak. There should be no shift in the meter reading. (Do not confuse noise and drift for a shift in meter reading.)

4.2.14 Common Mode Rejection Check

1. Use the same setup as in paragraphs 4.2.13 except apply the signal between the (+) high and CASE terminals and connect the (+) high and (-) low terminals together.
2. Check Model 155 zero.
3. Set the function generator frequency to 50Hz and output to minimum.
 - A. Set the Model 155 power switch to ON, RANGE switch to 1 μ V and zero the instrument with the ZERO control. Allow time for the unit to stabilize (approximately one minute).
 - B. Increase the function generator output to 1V peak-to-peak. There should be no shift in the meter reading. (Do not confuse noise and drift for a shift in meter reading.)

4.3 TROUBLESHOOTING

The procedures which follow give instructions for repairing troubles which might occur in the Model 155. Use the procedures outlined and use only specified replacement parts. Table 4-1 lists equipment recommended for troubleshooting. If the trouble cannot be readily located or repaired, contact Keithley Instruments, Inc.

Table 4-4 contains the more common troubles which might occur. If the repairs indicated do not clear up the problem, do a circuit-by-circuit check of the instrument. See Section 3 for circuit descriptions.

4.3.1 Servicing Schedule

Periodically check the condition of the batteries (See paragraph 2.6). Except for battery replacement and calibration, the Model 155 requires no periodic maintenance.

4.3.2 Preliminary Procedures

Before troubleshooting, check the system to make sure that the Model 155 is indeed faulty. Once this is determined, turn

Table 4-4. Model 155 General Troubleshooting

Symptom	Probable Cause	Solution
Excessive Zero Offset	Input Transistors may be defective.	Check Q101 and Q102 (see paragraph 4.3.3 and replace if faulty).
	Batteries failing.	Replace batteries.
	DC amplifier balance potentiometer, R151, out of adjustment.	Adjust (see paragraph 4.3.3 or 4.2.4).
	Mechanical meter zero out of adjustment.	Adjust
Excessive Offset Current	Input transistors may be defective.	Check Q101 and Q102 (see paragraph 4.3.3 and replace if faulty).
	Offset current suppress potentiometer, R109, out of adjustment.	Adjust (see paragraph 4.2.7).
Instrument inaccurate on all ranges.	Meter calibrate potentiometer, R183, out of adjustment	Adjust (see paragraph 4.2.5).
Instrument inaccurate on 300mV and 1V ranges.	Accuracy set potentiometer, R104, out of adjustment.	Adjust (see paragraphs 4.2.6 and 4.2.12).
Instrument inaccurate on 3V and higher ranges.	Accuracy set potentiometer, R101, out of adjustment.	Adjust (see paragraphs 4.2.6 and 4.2.12).
Apparent oscillation in output.	Chopper frequency beating with line frequency.	Adjust multivibrator frequency set potentiometer, R178 (see paragraph 4.3.3 and 4.2.3).
	Multivibrator frequency set potentiometer, R178, out of adjustment.	Check (see paragraph 4.3.3). Adjust (see paragraph 4.2.3).

the power switch to OFF. Refer to Table 4-1 which lists the equipment recommended for troubleshooting. If necessary, disassemble the instrument so that the circuits are accessible and the power may be safely turned on.

Before starting a step-by-step check, inspect the circuit visually for any broken wires, dirt between switch contacts, loose battery clips, etc.

Turn the Model 155 power switch to ON and check the circuit (see paragraph 4.3.2.) When the trouble is located, turn the power switch OFF, make the repair and reassemble the instrument.

4.3.3 Procedures To Guide Troubleshooting

1. If the instrument will not operate, check the condition of the batteries, If these are found to be defective, replace them.
2. If the batteries are satisfactory, set the RANGE switch to 1000V, power switch to ZERO CHK. Check the voltage at the plus and minus battery check points, these are points

1 (collector Q119) and 2 (collector Q117) given in Figure 4-1. The voltage at each point should be a minimum of +16.2 and -16.2V respectively.

Check for battery current of less than 3mA if the plus and minus 16.2V cannot be obtained. If the 3mA is present, then there is a short circuit between the battery leads in the power switch.

If the 3mA cannot be obtained, then there is a shorted component loading the supplies. Replace the faulty component.

3. If the plus and minus battery supplies are found to be satisfactory, check the filtered plus and minus battery supplies. These are points 3 (R167) and 4 (R168) given in Figure 4-1. Check these supplies for a minimum of 14.9V If unobtainable, the fault is in the associated circuitry components.
4. If the filtered battery voltages are satisfactory, check the regulated plus and minus 6V supplies for +6V \pm 2V and -6V \pm 2V respectively. Check these voltages at points 5 and 6 (emitters Q117 and Q119 respectively) shown in Figure 4-1. If these values are unobtainable, the fault lies in the associated circuitry.

5. If the regulated voltage supplies are satisfactory, the trouble may lie in the multivibrator circuit. Check the multivibrator waveform with an oscilloscope at the gates of FET Q101 and Q102. These are at test points 7 (anode of D105) and 8 (emitter Q123) in Figure 4-1. Set the oscilloscope to 2V per division vertical and 1msec per division horizontal. The waveform should be near symmetrical 7 to 12V peak-to-peak (see Figure 4-3). A little overshoot may be observed on some units.
 - A. If both chopper drives are present, remove the gate lead of Q101 and Q102 from the teflon® standoff taking care not to damage Q101 and Q102. If both drives are not present, check the multivibrator circuit. If the chopper drives are still present, replace Q101 and Q102.
 - B. After either repairing the multivibrator or replacing the FETs, if both chopper drivers are present, input +10V to the Model 155 and check for a 1mV signal at the output of the FETs (test point 9, Figure 4-1). If there is no signal, the fault lies in the input harnessing, switches or the input filter. After repairing the fault and/or replacing Q101 and Q102, reinstall the gate leads.

NOTE

Defective input FETs Q101 and Q102 may be the cause of AC amplifier unbalance or large current offset.

6. Check for a square wave at the demodulator test point (point 10, Figure 4-1). If there is no square wave, the fault lies in the AC amplifier transistors Q103 to Q107. Find and replace the defective transistor(s). To localize the trouble in the AC amplifier

refer to Figure 4-6. Nominal voltage measurements are made with the feedback test point (point 11 in Figure 4-1) jumpered to low, the Model 155 RANGE switch set to 1000V and power switch at ZERO CHK. Voltages may be slightly higher or lower than the nominal voltage listed.

7. If there is a square wave at the demodulator test point, momentarily short the test point to low and then check for a square wave. If there is no square wave, the problem lies in the demodulator circuit.
8. If the demodulator is satisfactory, keep the demodulator test point shorted to low and check the DC amplifier operation.
 - A. Turn the DC amplifier balance potentiometer, R151, completely clockwise. The meter should peg in the minus direction. Then turn R151 completely counter-clockwise. The meter should peg in the plus direction.
 - B. If the meter does not peg in both cases, the problem lies in the DC amplifier circuit.
 - C. To localize the trouble in the DC amplifier, refer to Figure 4-7. Nominal voltage measurements are made with the Model 195 DMM. The demodulator test point is jumpered to low, the RANGE switch at 1000V and power switch t ZERO CHK. The Model 195 common must be above ground.

Connect the Model 195 across the collectors of transistors Q109 and Q110. Turn DC balance potentiometer, R151, to achieve a reading near 0V (+10mV balance). When balanced, the voltage to low should be near nominal values listed. If the DC amplifier circuit is found to operate satisfactorily, the trouble is in the output switching or meter circuits.

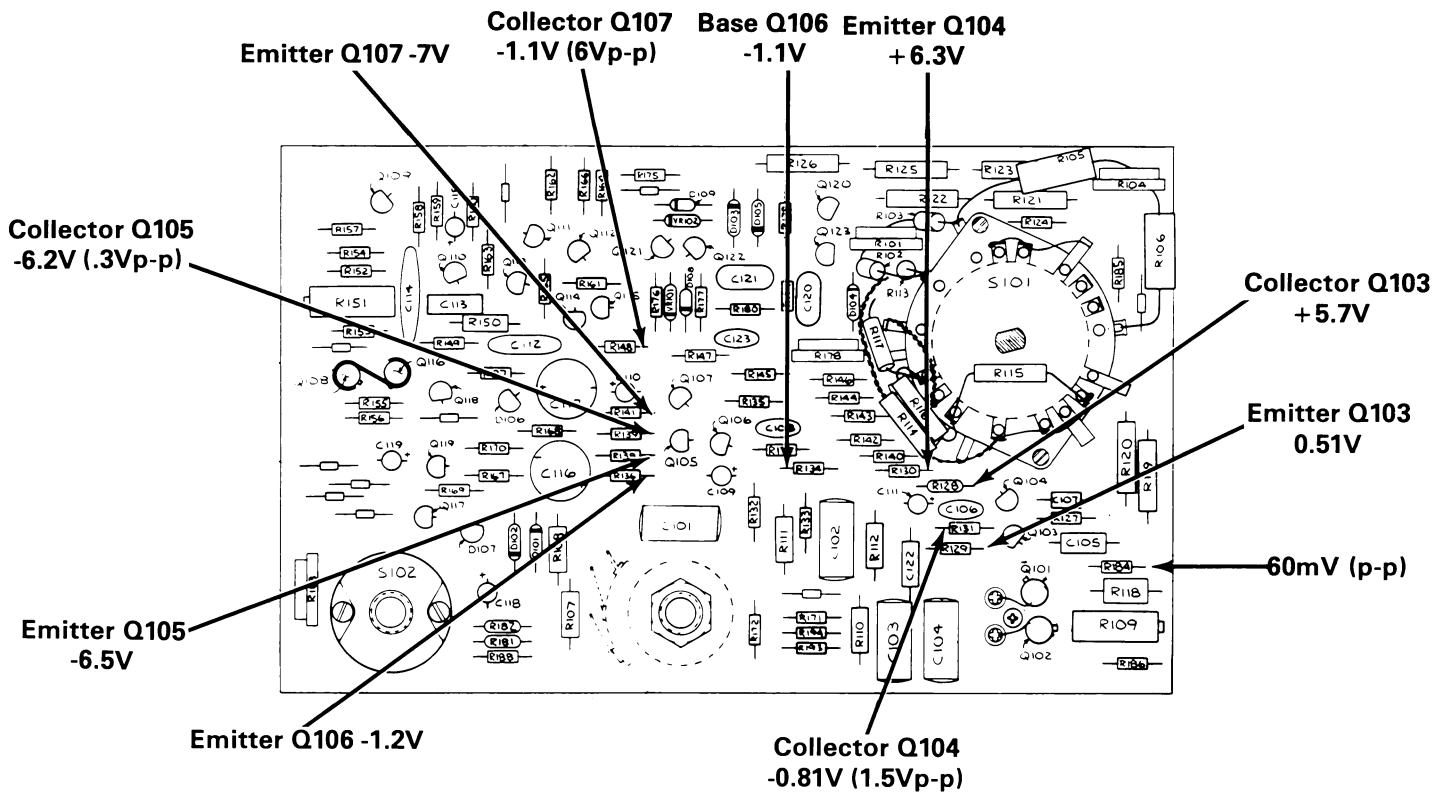

NOTE: Indicated nominal voltages to be expected at the test points.

Figure 4-6. AC Amplifier Circuit Test Points

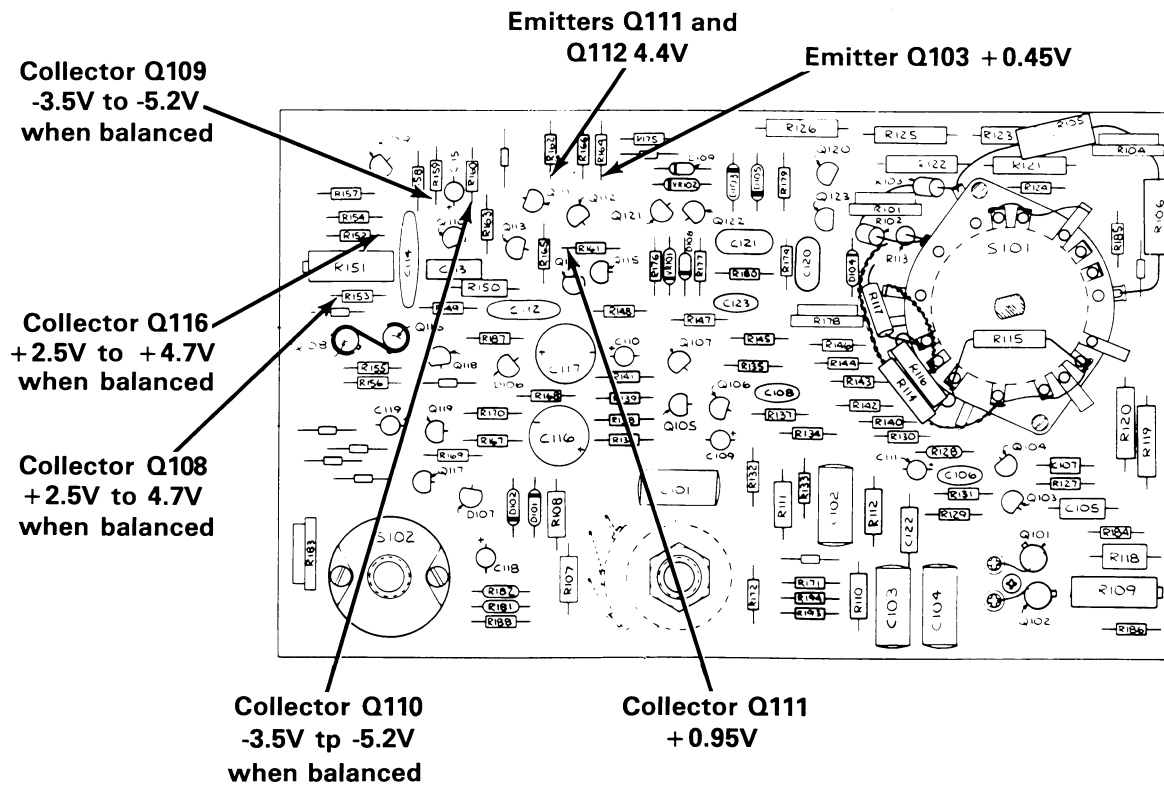

NOTE: Indicated nominal voltages to be expected at test points.

Figure 4-7. DC Amplifier Circuit Test Points

SECTION 5 REPLACEABLE PARTS

5.1 INTRODUCTION

This section contains replacement parts information and a schematic diagram for the Model 155.

5.2 PARTS LIST

Model 155 electrical parts list is contained in Table 5-2. A mechanical parts list for the Model 155 is contained in Table 5-3. Figure 5-1 shows assembly of the cover, while Figure 5-2 contains a chassis bottom view.

5.3 ORDERING INFORMATION

Keithley Instruments maintains a complete inventory of all normal replacement parts. To place an order, or to obtain information concerning replacement parts, contact your Keithley representative or the factory. When ordering parts, include the following information:

- Instrument Model Number
- Instrument Serial Number
- Part Description
- Circuit designation, including schematic and component layout numbers (if applicable).
- Keithley Part Number

5.4 FACTORY SERVICE

If the instrument is to be returned to the factory for service, carefully pack the instrument and include the following:

1. Complete the service form which follows this section and return it with the instrument.

2. Advise as to the warranty status of the instrument.
3. Write ATTENTION REPAIR DEPARTMENT on the shipping label.

5.5 SPECIAL HANDLING OF STATIC SENSITIVE DEVICES

MOS devices are designed to function at high impedance levels. Normal static charge can destroy these devices. Table 5-1 lists all the static sensitive devices of the Model 155. Steps 1 through 7 provide instructions on how to avoid damaging these devices.

Table 5-1. Model 155 Static Sensitive Devices

Reference Designation	Keithley Part No.
Q101, Q102	24598

1. Devices should be handled and transported in protective containers, antistatic tubes or conductive foam.
2. Use a properly grounded work bench and a grounding wristwrap.
3. Handle devices by the body only.
4. PC boards must be grounded to bench while inserting devices.
5. Use antistatic solder removers.
6. Use grounded tip soldering irons.
7. After devices are soldered or inserted into sockets they are protected and normal handling can resume.

5.6 SCHEMATIC DIAGRAM

A schematic diagram of the Model 155 is shown in Figure 5-3.

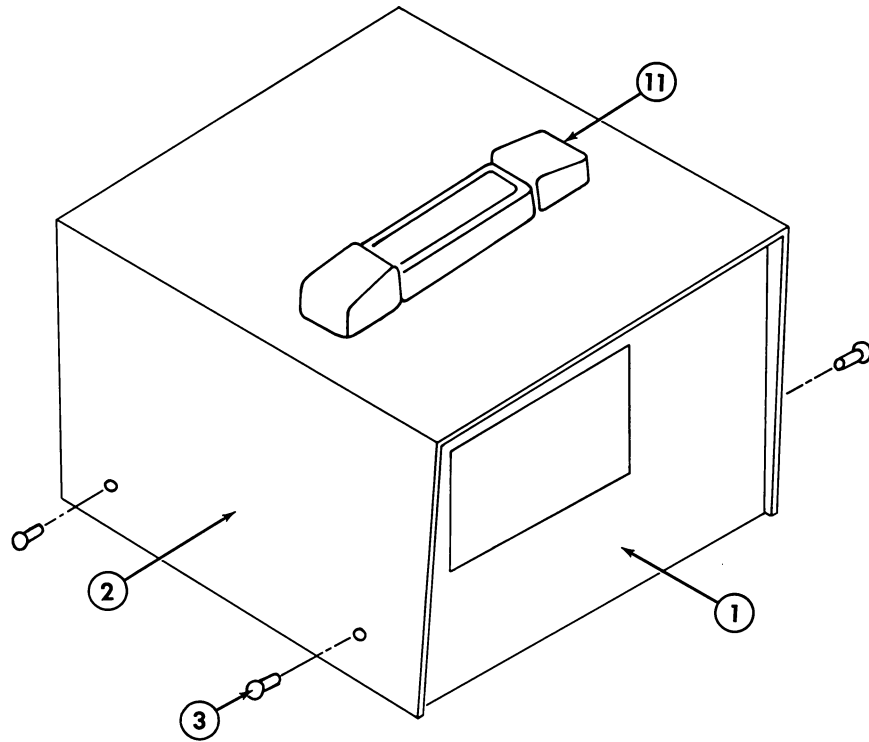

Figure 5-1. Model 155 Cover Assembly

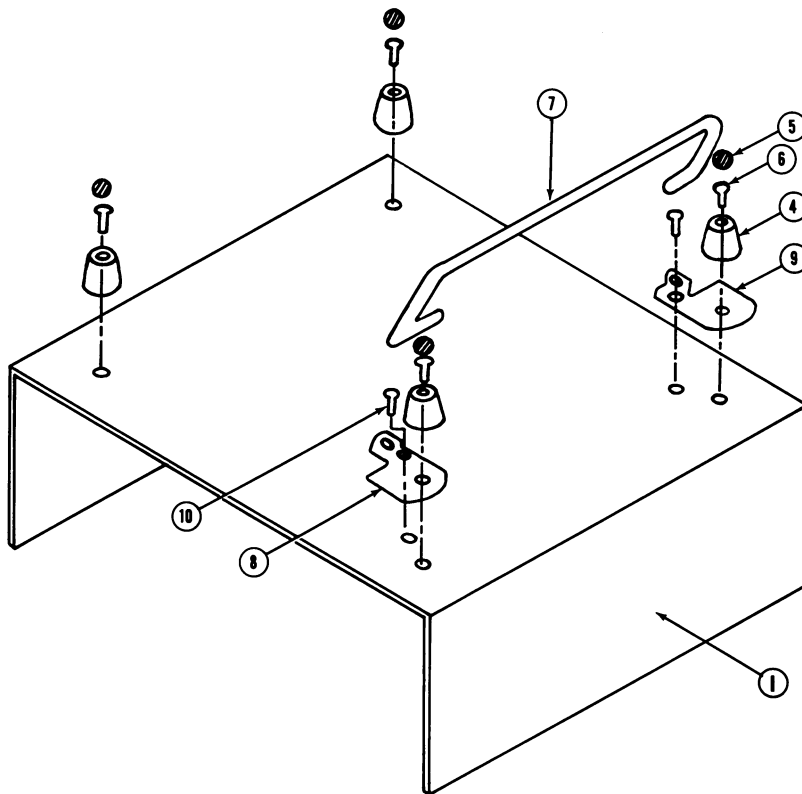

Figure 5-2. Model 155 Chassis Bottom View

Table 5-2. Model 155 Mechanical Parts List

Description	Quantity Per Assembly	Keithley Part No.
1. Chassis	1	22586
Top Cover Assembly	—	22673
2. Cover, Sheet Metal	1	22585
3. Screws	4	—
Handle Assembly	—	—
4. Feet	4	FE-5
5. Ball	4	FE-6
6. Screws #8-32 × 3/8" Phillips, Pan Head	4	—
Tilt Bail Assembly	—	—
7. Bail	1	17147
8. Right Assembly	1	19206
9. Left Assembly	1	19205
10. Screws #6-32 × 1/4" Phillips, Pan Head	2	—
11. Handle	1	HH-18
12. Screws #6-32 × 3/8" R.H. Slotted	2	—
Feet Assembly	—	—
Knob Range		KN-52
Knob Zero		KN-53
Knob on/off		KN-54

Table 5-3. Model 155 Electrical Replaceable Parts

Circuit Desig.	Description	Keithley Part No.
BT101	9V Zinc Carbon (2 cells required)	BA-17
BT102	9V Zinc Carbon (2 cells required)	BA-17
C101	Capacitor, 1 μ F, 100V, Metalized Mylar	C-245-1
C102	Capacitor, 1 μ F, 100V, Metalized Mylar	C-245-1
C103	Capacitor, 1 μ F, 100V, Metalized Mylar	C-245-1
C104	Capacitor, 1 μ F, 100V, Metalized Mylar	C-245-1
C105	Capacitor, .01 μ F, 200V, Metalized Mylar	C-47-.01
C106	Capacitor, 470pF, 500V, Ceramic Disc	C-64-470
C107	Capacitor, 10 μ F, 20V, Tantalum	C-80-10
C108	Capacitor, .0022 μ F, 500V, Ceramic Disc	C-152-.0022
C109	Capacitor, 1 μ F, 35V, Tantalum	C-170-1
C110	Capacitor, 1 μ F, 35V, Tantalum	C-170-1
C111	Capacitor, 1 μ F, 35V, Tantalum	C-170-1
C112	Capacitor, .1 μ F, 200V, Metalized Mylar	C-201-.1
C113	Capacitor, .0022 μ F, 100V, Polyethylene	C-64-2200p
C114	Capacitor, .01 μ F, 500V, Ceramic Disc	C-22-.01
C115	Capacitor, 1 μ F, 35V, Tantalum	C-170-1
C116	Capacitor, 100 μ F, 25V, Aluminum Electrolytic	C-211-100
C117	Capacitor, 100 μ F, 25V, Aluminum Electrolytic	C-211-100
C118	Capacitor, 1 μ F, 35V, Tantalum	C-170-1
C119	Capacitor, 1 μ F, 35V, Tantalum	C-170-1
C120	Capacitor, 1000pF, 100V, Silver Mica	C-21-1000p
C121	Capacitor, 1000pF, 100V Silver Mica	C-21-1000p
C122	Capacitor, 10 μ F, 20V, Tantalum	C-80-10

Table 5-3. Model 155 Electrical Replaceable Parts (Cont.)

Circuit Desig.	Description	Keithley Part No.
C123	Capacitor, .001 μ F, 1000V, Ceramic Disc	C-64-.001
C124	Capacitor, .01 μ F, 1200V, Metalized Polycarbonate	C-262-.01
C125	Capacitor, .01 μ F, 1200V, Metalized Polycarbonate	C-262-.01
C126	Capacitor, (OPTIONAL), 500V, Polystyrene	C-138-*
D101	Diode, Silicon, 1N645	RF-14
D102	Diode, Silicon, 1N645	RF-14
D103	Diode, Silicon, 1N645	RF-14
D104	Diode, Silicon, 1N645	RF-14
D105	Diode, Silicon, 1N645	RF-14
D106	Low Leakage Transistor (PNP)	24218A
D107	Low Leakage Transistor (PNP)	24218A
D108	Diode, Silicon, 1N914	RF-28
D109	Diode, Silicon, 1N914	RF-28
J101	+ Input Terminal (RED)	BP-8
J102	-Input Terminal (BLACK)	BP-8
J103	Guard Terminal (BLUE)	BP-8
J104	Case Terminal (GREEN)	BP-8
M101	Meter	ME-82
P101	Barrier Strip Connector	TE-68
	Shorting Links (2 required)	BP-17
Q101	P-Channel MOSFET (Selected at Factory)	24598A
Q102	P-Channel MOSFET (Selected at Factory)	24598A
Q103	NPN Transistor (Selected at Factory)	24217A
Q104	PNP Transistor, 2N5087	TG-61
Q105	PNP Transistor, 2N5087	TG-61
Q106	NPN Transistor (Selected at Factory)	24217A
Q107	NPN Transistor (Selected at Factory)	24217A
Q108	NPN Transistor, A-642L	TG-64
Q109	PNP Transistor, 2N5087	TG-61
Q110	PNP Transistor, 2N5087	TG-61
Q111	NPN Transistor (Selected at Factory)	24219A
Q112	NPN Transistor (Selected at Factory)	24219A
Q113	NPN Transistor (Selected at Factory)	24217A
Q114	NPN Transistor (Selected at Factory)	24217A
Q115	PNP Transistor, 2N5087	TG-61
Q116	NPN Transistor, A-642L	TG-64
Q117	NPN Transistor (Selected at Factory)	24217A
Q118	N-Channel J-FET, 2N5457	TG-41
Q119	PNP Transistor (Selected at Factory)	TG-61
Q120	NPN Transistor (Selected at Factory)	24220A
Q121	NPN Transistor (Selected at Factory)	24220A
Q122	NPN Transistor (Selected at Factory)	24220A
Q123	NPN Transistor (Selected at Factory)	24220A
R101	Pot, 500k	RP-111-500k
R102	Resistor, 4.42M, 1%, 1/2W, Carbon	R-12-4.42M
R103	Resistor, 4.42M, 1%, 1/2W, Carbon	R-12-4.42M
R104	Pot, 3.5M	RP-59-3.5M
R105	Resistor, 44M, 1%, 1W, Carbon	R-13-44M
R106	Resistor, 44M, 1%, 1W, Carbon	R-13-44M
R107	Resistor, 12k, 10%, 1/2W, Composition	R-1-12k
R108	Resistor, 12k, 10%, 1/2W, Composition	R-1-12k
R109	Pot, 1M	RP-64-1M

Table 5-3. Model 155 Electrical Replaceable Parts (Cont.)

Circuit Desig.	Description	Keithley Part No.
R110	Resistor, 10 ⁹ , 20%, 1/2W, Composition	R-37-10 ⁹
R111	Resistor, 22k, 10%, 1/2W, Composition	R-1-22k
R112	Resistor, 22k, 10%, 1/2W, Composition	R-1-22k
R113	Resistor, 450k, 1/4%, 1/2W, Metal Film	R-127-450k
R114	Resistor, 450k, 1/4%, 1/2W, Metal Film	R-127-450k
R115	Resistor, 90k, 1/4%, 1/2W, Metal Film	R-127-90k
R116	Resistor, 9k, 1/4%, 1/2W, Metal Film	R-127-9k
R117	Resistor, 1k, 1/4%, 1/2W, Metal Film	R-127-1k
R118	Resistor, 9.9 Ω , .1%, 1/4W, Wire Wound	R-95-9.9
R119	Resistor, 90 Ω , .1%, 1/2W, Metal Film	R-135-90
R120	Resistor, 900 Ω , .1%, 1/2W, Metal Film	R-135-900
R121	Resistor, 7.66M, 1%, 1/2W, Carbon	R-12-7.66M
R122	Resistor, 2.34M, 1%, 1/2W, Carbon	R-12-2.34M
R123	Resistor, 666.67, 1/4%, 1/2W, Metal Film	R-127-666.67k
R124	Resistor, 1k, 5%, 1/4W, Composition	R-76-1k
R125	Resistor, 233.33k, 1/4%, 1/2W, Metal Film	R-127-233.33k
R126	Resistor, 99k, 1/4%, 1/2W, Metal Film	R-127-99k
R127	Resistor, 1M, 5%, 1/4W, Composition	R-76-1M
R128	Resistor, 1M, 1%, 1/8W, Metal Film	R-88-1M
R129	Resistor, 1k, 5%, 1/4W, Composition	R-76-1M
R130	Resistor, 330k, 5%, 1/4W, Composition	R-76-330k
R131	Resistor, 33k, 5%, 1/4W, Composition	R-76-33k
R132	Resistor, 390k, 5%, 1/4W, Composition	R-76-390k
R133	Resistor, 1M, 5%, 1/4W, Composition	R-76-1M
R134	Resistor, 100k, 5%, 1/4W, Composition	R-76-100k
R135	Resistor, 1.5k, 5%, 1/4W, Composition	R-76-1.5k
R136	Resistor, 1.5M, 5%, 1/4W, Composition	R-76-1.5M
R137	Resistor, 1M, 5%, 1/4W, Composition	R-76-1M
R138	Resistor, 220k, 5%, 1/4W, Composition	R-76-220k
R139	Resistor, 220k, 5%, 1/4W, Composition	R-76-220k
R140	Resistor, 270k, 5%, 1/4W, Composition	R-76-270k
R141	Resistor, 165k, 1%, 1/8W, Metal Film	R-88-165k
R142	Resistor, 12M, 5%, 1/4W, Composition	R-76-12M
R143	Resistor, 8.2M, 5%, 1/4W, Composition	R-76-8.2M
R144	Resistor, 1M, 5%, 1/4W, Composition	R-76-1M
R145	Resistor, 150k, 5%, 1/4W, Composition	R-76-150k
R146	Resistor, 220k, 5%, 1/4W, Composition	R-76-220k
R147	Resistor, 15k, 5%, 1/4W, Composition	R-76-15k
R148	Resistor, 15k, 5%, 1/4W, Composition	R-76-15k
R149	Resistor, 100k, 5%, 1/4W, Composition	R-76-100k
R150	Resistor, 109 Ω	R-37-109
R151	Pot, 100k	RP-64-100k
R152	Resistor, 270k, 5%, 1/4W, Composition	R-76-270k
R153	Resistor, 270k, 5%, 1/4W, Composition	R-76-270k
R154	Resistor, 1k, 5%, 1/4W, Composition	R-76-1k
R155	Resistor, 330k, 5%, 1/4W, Composition	R-76-330k
R156	Resistor, 100k, 5%, 1/4W, Composition	R-76-100k
R157	Resistor, 150k, 5%, 1/4W, Composition	R-76-150k
R158	Resistor, 1.5k, 5%, 1/4W, Composition	R-76-1.5k
R159	Resistor, 330k, 5%, 1/4W, Composition	R-76-330k
R160	Resistor, 330k, 5%, 1/4W, Composition	R-76-330k
R161	Resistor, 560k, 5%, 1/4W, Composition	R-76-560k
R162	Resistor, 220k, 5%, 1/4W, Composition	R-76-220k

Table 5-3. Model 155 Electrical Replaceable Parts (Cont.)

Circuit Desig.	Description	Keithley Part No.
R163	Resistor, 10k, 5%, 1/4W, Composition	R-76-10k
R164	Resistor, 330k, 5%, 1/4W, Composition	R-76-330k
R165	Resistor, 4.7k, 5%, 1/4W, Composition	R-76-4.7k
R166	Resistor, 4.7k, 5%, 1/4W, Composition	R-76-4.7k
R167	Resistor, 10k, 5%, 1/4W, Composition	R-76-10k
R168	Resistor, 10k, 5%, 1/4W, Composition	R-76-10k
R169	Resistor, 330k, 5%, 1/4W, Composition	R-76-330k
R170	Resistor, 330k, 5%, 1/4W, Composition	R-76-330k
R171	Resistor, 1M, 5%, 1/4W, Composition	R-76-1M
R172	Resistor, 100k, 5%, 1/4W, Composition	R-76-100k
R173	Pot, 1M	RP-69-1M
R174	Resistor, 1M, 5%, 1/4W, Composition	R-76-1M
R175	Resistor, 1M, 5%, 1/4W, Composition	R-76-1M
R176	Resistor, 6.8M, 5%, 1/4W, Composition	R-76-6.8M
R177	Resistor, 6.8M, 5%, 1/4W, Composition	R-76-6.8M
R178	Pot, 3.5M	RP-59-3.5M
R179	Resistor, 1M, 5%, 1/4W, Composition	R-76-1M
R180	Resistor, 1M, 5%, 1/4W, Composition	R-76-1M
R181	Resistor, 8.85k, 1%, 1/8W, Metal Film	R-88-8.85k
R182	Resistor, 182k, 1%, 1/8W, Metal Film	R-88-182k
R183	Pot, 5k	RP-111-5k
R184	Resistor, 1k, 5%, 1/4W, Composition	R-76-1k
R185	Resistor, 1K, 5%, 1/4W, Composition	R-76-1k
R186	Resistor, 47k, 5%, 1/4W, Composition	R-76-47k
R187	Resistor, 10M, 5%, 1/4W, Composition	R-76-10M
R188	Resistor, 470Ω, 5%, 1/4W, Composition	R-76-470
R193	Resistor, 1.5M, 5%, 1/4W, Composition	R-76-1.5M
R194	Resistor, 560k, 5%, 1/4W, Composition	R-76-560k
S101	Range Switch (Detent and Shaft Assembly) Spacer (2 required)	SW310 23630A
S101	Range SW Deck	SW-310A
S102	Power Switch (Detent and Shaft Assembly) Spacer (2 required)	SW312 23631A
S102	Power SW Deck Lexon Spacer for Range SW	SW-312A 23630
VR101	3.3V Zener Diode, 1N746A	DZ-40
VR102	3.3V Zener Diode, 1N746A	DZ-40