

# Model 7164 20-Channel Scanner Card

---

## Instruction Manual

Contains Operating and Servicing Information

**KEITHLEY**

## WARRANTY

Keithley Instruments, Inc. warrants this product to be free from defects in material and workmanship for a period of 1 year from date of shipment.

Keithley Instruments, Inc. warrants the following items for 90 days from the date of shipment: probes, cables, rechargeable batteries, diskettes, and documentation.

During the warranty period, we will, at our option, either repair or replace any product that proves to be defective.

To exercise this warranty, write or call your local Keithley representative, or contact Keithley headquarters in Cleveland, Ohio. You will be given prompt assistance and return instructions. Send the product, transportation prepaid, to the indicated service facility. Repairs will be made and the product returned, transportation prepaid. Repaired or replaced products are warranted for the balance of the original warranty period, or at least 90 days.

## LIMITATION OF WARRANTY

This warranty does not apply to defects resulting from product modification without Keithley's express written consent, or misuse of any product or part. This warranty also does not apply to fuses, software, non-rechargeable batteries, damage from battery leakage, or problems arising from normal wear or failure to follow instructions.

**THIS WARRANTY IS IN LIEU OF ALL OTHER WARRANTIES, EXPRESSED OR IMPLIED, INCLUDING ANY IMPLIED WARRANTY OF MERCHANTABILITY OR FITNESS FOR A PARTICULAR USE. THE REMEDIES PROVIDED HEREIN ARE BUYER'S SOLE AND EXCLUSIVE REMEDIES.**

**NEITHER KEITHLEY INSTRUMENTS, INC. NOR ANY OF ITS EMPLOYEES SHALL BE LIABLE FOR ANY DIRECT, INDIRECT, SPECIAL, INCIDENTAL OR CONSEQUENTIAL DAMAGES ARISING OUT OF THE USE OF ITS INSTRUMENTS AND SOFTWARE EVEN IF KEITHLEY INSTRUMENTS, INC., HAS BEEN ADVISED IN ADVANCE OF THE POSSIBILITY OF SUCH DAMAGES. SUCH EXCLUDED DAMAGES SHALL INCLUDE, BUT ARE NOT LIMITED TO: COSTS OF REMOVAL AND INSTALLATION, LOSSES SUSTAINED AS THE RESULT OF INJURY TO ANY PERSON, OR DAMAGE TO PROPERTY.**

## KEITHLEY

Keithley Instruments, Inc. • 28775 Aurora Road • Cleveland, OH 44139 • 216-248-0400 • Fax: 216-248-6168 • <http://www.keithley.com>

CHINA:	Keithley Instruments China • Holiday Inn Lido • Office Building 404C • Beijing, 100004 • 8610-4362871 • Fax: 8610-4366165
FRANCE:	Keithley Instruments SARL • BP 60 • 3 allée des Garays • 91122 Palaiseau Cédex • 31-6-0115153 • Fax: 31-6-0117726
GERMANY:	Keithley Instruments GmbH • Landsberger Straße 65 • 82110 Germering • 49-89-849307-0 • Fax: 49-89-84930759
GREAT BRITAIN:	Keithley Instruments, Ltd. • The Minster • 58 Portman Road • Reading, Berkshire RG30 1EA • 44-01734-575666 • Fax: 44-01734-596469
ITALY:	Keithley Instruments SRL • Viale S. Gimignano 38 • 20146 Milano • 39-2-48303008 • Fax: 39-2-48302274
JAPAN:	Keithley Instruments Far East KK • Aibido Bldg. • 7-20-2 Nishishinjuku • Shinjuku-ku, Tokyo 160 • 81-3-5389-1964 • Fax: 81-3-5389-2068
NETHERLANDS:	Keithley Instruments BV • Avelingen West 49 • 4202 MS Gorinchem • 31-(0)183-635333 • Fax: 31-(0)183-630821
SWITZERLAND:	Keithley Instruments SA • Kriesbachtstrasse 4 • 8600 Dübendorf • 41-1-8219444 • Fax: 41-1-8203081
TAIWAN:	Keithley Instruments Taiwan • 1, Ming-Yu First Street • Hsinchu, Taiwan, R.O.C. • 886-35-778462 • Fax: 886-35-778455

# Model 7164 20-Channel Scanner Card Instruction Manual

©1988, Keithley Instruments, Inc.  
All rights reserved.  
Cleveland, Ohio, U.S.A.  
Fifth Printing, May 1999  
Document Number: 7164-901-01 Rev. E

# Safety Precautions

The following safety precautions should be observed before using this product and any associated instrumentation. Although some instruments and accessories would normally be used with non-hazardous voltages, there are situations where hazardous conditions may be present.

This product is intended for use by qualified personnel who recognize shock hazards and are familiar with the safety precautions required to avoid possible injury. Read the operating information carefully before using the product.

The types of product users are:

**Responsible body** is the individual or group responsible for the use and maintenance of equipment, for ensuring that the equipment is operated within its specifications and operating limits, and for ensuring that operators are adequately trained.

**Operators** use the product for its intended function. They must be trained in electrical safety procedures and proper use of the instrument. They must be protected from electric shock and contact with hazardous live circuits.

**Maintenance personnel** perform routine procedures on the product to keep it operating, for example, setting the line voltage or replacing consumable materials. Maintenance procedures are described in the manual. The procedures explicitly state if the operator may perform them. Otherwise, they should be performed only by service personnel.

**Service personnel** are trained to work on live circuits, and perform safe installations and repairs of products. Only properly trained service personnel may perform installation and service procedures.

Exercise extreme caution when a shock hazard is present. Lethal voltage may be present on cable connector jacks or test fixtures. The American National Standards Institute (ANSI) states that a shock hazard exists when voltage levels greater than 30V RMS, 42.4V peak, or 60VDC are present. **A good safety practice is to expect that hazardous voltage is present in any unknown circuit before measuring.**

Users of this product must be protected from electric shock at all times. The responsible body must ensure that users are prevented access and/or insulated from every connection point. In some cases, connections must be exposed to potential human contact. Product users in these circumstances must be trained to protect themselves from the risk of electric shock. If the circuit is capable of operating at or above 1000 volts, **no conductive part of the circuit may be exposed.**

As described in the International Electrotechnical Commission (IEC) Standard IEC 664, digital multimeter measuring circuits (e.g., Keithley Models 175A, 199, 2000, 2001, 2002, and 2010) are Installation Category II. All other instruments' signal terminals are Installation Category I and must not be connected to mains.

Do not connect switching cards directly to unlimited power circuits. They are intended to be used with impedance limited sources. **NEVER** connect switching cards directly to AC mains. When connecting sources to switching cards, install protective devices to limit fault current and voltage to the card.

Before operating an instrument, make sure the line cord is connected to a properly grounded power receptacle. Inspect the connecting cables, test leads, and jumpers for possible wear, cracks, or breaks before each use.

For maximum safety, do not touch the product, test cables, or any other instruments while power is applied to the circuit under test. **ALWAYS** remove power from the entire test system and discharge any capacitors before: connecting or disconnecting cables or jumpers, installing or

removing switching cards, or making internal changes, such as installing or removing jumpers. Do not touch any object that could provide a current path to the common side of the circuit under test or power line (earth) ground. Always make measurements with dry hands while standing on a dry, insulated surface capable of withstanding the voltage being measured.

The instrument and accessories must be used in accordance with its specifications and operating instructions or the safety of the equipment may be impaired.

Do not exceed the maximum signal levels of the instruments and accessories, as defined in the specifications and operating information, and as shown on the instrument or test fixture panels, or switching card.

When fuses are used in a product, replace with same type and rating for continued protection against fire hazard.

Chassis connections must only be used as shield connections for measuring circuits, NOT as safety earth ground connections.

If you are using a test fixture, keep the lid closed while power is applied to the device under test. Safe operation requires the use of a lid interlock.

If a  screw is present, connect it to safety earth ground using the wire recommended in the user documentation.

The  symbol on an instrument indicates that the user should refer to the operating instructions located in the manual.

The  symbol on an instrument shows that it can source or measure 1000 volts or more, including the combined effect of normal and common mode voltages. Use standard safety precautions to avoid personal contact with these voltages.

The **WARNING** heading in a manual explains dangers that might result in personal injury or death. Always read the associated information very carefully before performing the indicated procedure.

The **CAUTION** heading in a manual explains hazards that could damage the instrument. Such damage may invalidate the warranty.

Instrumentation and accessories shall not be connected to humans.

Before performing any maintenance, disconnect the line cord and all test cables.

To maintain protection from electric shock and fire, replacement components in mains circuits, including the power transformer, test leads, and input jacks, must be purchased from Keithley Instruments. Standard fuses, with applicable national safety approvals, may be used if the rating and type are the same. Other components that are not safety related may be purchased from other suppliers as long as they are equivalent to the original component. (Note that selected parts should be purchased only through Keithley Instruments to maintain accuracy and functionality of the product.) If you are unsure about the applicability of a replacement component, call a Keithley Instruments office for information.

To clean an instrument, use a damp cloth or mild, water based cleaner. Clean the exterior of the instrument only. Do not apply cleaner directly to the instrument or allow liquids to enter or spill on the instrument. Products that consist of a circuit board with no case or chassis (e.g., data acquisition board for installation into a computer) should never require cleaning if handled according to instructions. If the board becomes contaminated and operation is affected, the board should be returned to the factory for proper cleaning/servicing.

# SPECIFICATIONS

## 7164-D

**CHANNELS PER CARD:** 20.

**CONTACT TYPE:** Dry reed.

**CONTACT CONFIGURATION:** 2-pole Form A, common guard/shield connection.

**CONNECTOR TYPE:** 50-pin D connector.

**RELAY DRIVE CURRENT:** 30mA per relay typical.

**MAXIMUM SIGNAL LEVEL:** 100V peak, 0.5A rms switched, 1A rms carry, 10VA (resistive load only).

**CONTACT LIFE:**  $>10^8$  closures cold switching;  $>10^7$  closures at maximum signal level.

**CONTACT RESISTANCE:**  $<400m\Omega$  initial,  $2\Omega$  to rated life.

**CONTACT POTENTIAL:**  $<50\mu V$  per contact pair with copper leads.

**ACTUATION TIME:**  $<2msec.$ , exclusive of mainframe.

**CHANNEL ISOLATION:**  $>10^9\Omega$ ,  $<20pF$ .

**INPUT ISOLATION:** Differential:  $>10^9\Omega$ ,  $<50pF$ . Common Mode:  $>10^9\Omega$ ,  $<150pF$ .

**CHANNEL TO CHANNEL VOLTAGE:** 100V peak.

**COMMON MODE VOLTAGE:** 200V peak.

**ENVIRONMENT:** Operating:  $0^\circ$  to  $50^\circ C$ , up to  $35^\circ C$  at 70% R.H. Storage:  $-25^\circ$  to  $65^\circ C$ .

**DIMENSIONS, WEIGHT:** 32mm high x 114mm wide x 272mm long (1-1/4 in. x 4-1/2 in. x 10-3/4 in.). Net weight 0.23kg (8 oz.).

## 7164-M

**CHANNELS PER CARD:** 20.

**CONTACT TYPE:** Mercury wetted reed.

**CONTACT CONFIGURATION:** 2-pole Form A, common guard/shield connection.

**CONNECTOR TYPE:** 50-pin D connector.

**RELAY DRIVE CURRENT:** 50mA per relay typical.

**MAXIMUM SIGNAL LEVEL:** 100V peak, 0.75A rms switched, 1A rms carry, 30VA.

**CONTACT LIFE:**  $>10^8$  closures cold switching;  $>10^8$  closures at maximum signal level.

**CONTACT RESISTANCE:**  $<400m\Omega$  to rated life.

**CONTACT POTENTIAL:**  $<75\mu V$  per contact pair with copper leads.

**ACTUATION TIME:**  $<2msec.$ , exclusive of mainframe.

**CHANNEL ISOLATION:**  $>10^9\Omega$ ,  $<20pF$ .

**INPUT ISOLATION:** Differential:  $>10^9\Omega$ ,  $<50pF$ . Common Mode:  $>10^9\Omega$ ,  $<150pF$ .

**CHANNEL TO CHANNEL VOLTAGE:** 100V peak.

**COMMON MODE VOLTAGE:** 200V peak.

**ENVIRONMENT:** Operating:  $0^\circ$  to  $50^\circ C$ , up to  $35^\circ C$  at 70% R.H. Storage:  $-25^\circ$  to  $65^\circ C$ .

**DIMENSIONS, WEIGHT:** 32mm high x 114mm wide x 272mm long (1-1/4 in. x 4-1/2 in. x 10-3/4 in.). Net weight 0.27kg (9.5 oz.).

# TABLE OF CONTENTS

## SECTION 1 — General Information

1.1	INTRODUCTION .....	1-1
1.2	WARRANTY INFORMATION .....	1-1
1.3	MANUAL ADDENDA .....	1-1
1.4	SAFETY SYMBOLS AND TERMS .....	1-2
1.5	SPECIFICATIONS .....	1-2
1.6	UNPACKING AND INSPECTION .....	1-2
1.6.1	Inspection for Damage.....	1-2
1.6.2	Shipping Contents.....	1-3
1.6.3	Instruction Manual.....	1-3
1.7	REPACKING FOR SHIPMENT .....	1-3
1.8	OPTIONAL ACCESSORIES .....	1-4

## SECTION 2 — Operation

2.1	INTRODUCTION .....	2-1
2.2	HANDLING PRECAUTIONS.....	2-2
2.3	EQUIVALENT CIRCUIT .....	2-2
2.4	SHIELD (G) .....	2-4
2.5	MULTI-CARD CONFIGURATIONS .....	2-5
2.6	CONNECTIONS .....	2-8
2.6.1	Connections Using Supplied “D” Connector .....	2-9
2.6.2	Connections Using Model 7164-MTC Cable .....	2-12
2.6.3	Shielded Cables .....	2-15
2.7	CARD INSTALLATION AND REMOVAL .....	2-15
2.7.1	Scanner Card Installation.....	2-16
2.7.2	Scanner Card Removal .....	2-19
2.8	MAINFRAME CONTROL OF SCANNER CARD .....	2-19
2.8.1	1-Pole Mode.....	2-19
2.8.2	Matrix Mode .....	2-20
2.8.3	Multi-Channel Systems .....	2-21
2.8.4	Scanner Switching Control.....	2-24
2.8.5	Reactive Loads.....	2-24

## **SECTION 3 — Application**

3.1	INTRODUCTION .....	3-1
3.2	LIFE CYCLE TESTING .....	3-1
3.3	BATTERY TESTING .....	3-3
3.4	CAPACITOR TESTING .....	3-4

## **SECTION 4 — Service Information**

4.1	INTRODUCTION .....	4-1
4.2	HANDLING AND CLEANING PRECAUTIONS .....	4-1
4.3	PERFORMANCE VERIFICATION .....	4-2
4.3.1	Environmental Conditions .....	4-2
4.3.2	Recommended Equipment .....	4-3
4.3.3	Connector Preparation .....	4-3
4.3.4	Channel Isolation Tests .....	4-5
4.3.5	Common Mode Input Isolation Tests .....	4-9
4.3.6	Contact Potential Tests .....	4-11
4.3.7	Path Resistance Tests .....	4-13
4.3.8	Differential Input Isolation Tests .....	4-15
4.4	RELAY INTERCHANGEABILITY .....	4-17

## **SECTION 5 — Replaceable Parts**

5.1	INTRODUCTION .....	5-1
5.2	PARTS LIST .....	5-1
5.3	ORDERING INFORMATION .....	5-1
5.4	FACTORY SERVICE .....	5-2
5.5	COMPONENT LAYOUT AND SCHEMATIC DIAGRAM .....	5-2



# LIST OF TABLES

## SECTION 2 — Operation

2-1	“D” Connector Pin Identification .....	2-11
2-2	Model 7164-MTC Conductor Identification.....	2-14
2-3	Channel Assignments .....	2-20
2-4	Model 705 Channel Assignments .....	2-21
2-5	Model 706 Channel Assignments .....	2-22
2-6	Model 705 Matrix Mode Crosspoint Assignments.....	2-22
2-7	Model 706 Matrix Mode Crosspoint Assignments.....	2-23

## SECTION 4 — Service Information

4-1	Verification Equipment.....	4-3
4-2	Relay Specification Comparisons.....	4-17

# LIST OF ILLUSTRATIONS

## SECTION 2 — Operation

2-1	Model 7164 Simplified Schematic .....	2-3
2-2	Model 7164-M Simplified Schematic.....	2-4
2-3	Shielded Measurement .....	2-5
2-4	Shielded Measurement (Floating) .....	2-5
2-5	Common Output Configuration .....	2-6
2-6	Separate Outputs Configuration.....	2-7
2-7	Male “D” Connector on Scanner Card (Pin Side Shown) .....	2-9
2-8	Female “D” Connector Pin Identification (Solder Cup Side Shown) .....	2-10
2-9	Model 7164-MTC.....	2-12
2-10	Card Installation in Model 705 .....	2-17
2-11	Card Installation in Model 706 .....	2-18
2-12	Limiting Capacitance Reaction Current .....	2-25
2-13	Limiting Inductive Reaction Voltage .....	2-26

## SECTION 3 — Application

3-1	Life Cycle Testing.....	3-2
3-2	Battery Testing .....	3-4
3-3	Capacitor Testing .....	3-5

## SECTION 4 — Service Information

4-1	Female Connector Preparation for Performance Verification.....	4-4
4-2	Channel Isolation .....	4-6
4-3	Female “D” Connector Pin Identification (Solder Cup Side Shown) .....	4-8
4-4	Input Isolation (Common Mode).....	4-10
4-5	Contact Potential.....	4-12
4-6	Path Resistance .....	4-14
4-7	Input Isolation (Differential).....	4-16

## **SECTION 5 — Replaceable Parts**

5-1	Model 7164, Component Location Drawing, Dwg. No. 7164-100 .....	5-3
5-2	Model 7164 Schematic Diagram, Dwg. No. 7164-106.....	5-5

# **SECTION 1**

## **General Information**

### **1.1 INTRODUCTION**

This section contains general information about the Model 7164 20-Channel Scanner Card.

#### **1.2 Features**

#### **1.3 Warranty Information**

#### **1.4 Manual Addenda**

#### **1.5 Safety Symbols and Terms**

#### **1.6 Specifications**

#### **1.7 Unpacking and Inspection**

#### **1.8 Repacking for Shipment**

#### **1.9 Optional Accessories**

### **1.2 WARRANTY INFORMATION**

Warranty information is located on the inside front cover of this instruction manual. Should your Model 7164 require warranty service, contact the Keithley representative or authorized repair facility in your area for further information. When returning the scanner card for repair, be sure to fill out and include the service form at the back of this manual in order to provide the repair facility with the necessary information.

### **1.3 MANUAL ADDENDA**

Any improvements or changes concerning the scanner card or manual will be explained in an addendum included with the unit. Be sure to note these changes and incorporate them into the manual.

## 1.4 SAFETY SYMBOLS AND TERMS

The following symbols and terms may be found on an instrument or used in this manual.

The symbol  on an instrument indicates that the user should refer to the operating instructions located in the instruction manual.

The symbol  on an instrument shows that high voltage may be present on the terminal(s). Use standard safety precautions to avoid personal contact with these voltages.

The **WARNING** heading used in this manual explains dangers that might result in personal injury or death. Always read the associated information very carefully before performing the indicated procedure.

The **CAUTION** heading used in this manual explains hazards that could damage the scanner card. Such damage may invalidate the warranty.

## 1.5 SPECIFICATIONS

Model 7164 specifications may be found at the front of this manual. These specifications are exclusive of the scanner mainframe specifications.

## 1.6 UNPACKING AND INSPECTION

### 1.6.1 Inspection for Damage

The Model 7164 is packaged in a resealable bag to protect it from contamination that could degrade performance. Before removing the card from the bag, observe the following precautions on handling.

1. Always grasp the card by the side edges. Do not touch the edge connector, board surfaces or components.
2. When not installed in the mainframe, keep the card in the bag and store in the original packing carton.

After removing the card from the bag, inspect it for any obvious signs of physical damage. Report any such damage to the shipping agent immediately. Save the original packing carton for possible future reshipment.

## **1.6.2 Shipping Contents**

The following items are included with every Model 7164 order:

- Model 7164 Scanner Card
- Model 7164 Instruction Manual
- Additional accessories as ordered

## **1.6.3 Instruction Manual**

If an additional instruction manual is required, order the manual package, Keithley part number 7164-901-00. The manual package includes an instruction manual and any pertinent addenda.

## **1.7 REPACKING FOR SHIPMENT**

Should it become necessary to return the Model 7164 for repair, carefully pack the unit in its original packing carton or the equivalent, and include the following information:

- Advise as to the warranty status of the scanner card.
- Write ATTENTION REPAIR DEPARTMENT on the shipping label.
- Fill out and include the service form located at the back of this manual.

## 1.8 OPTIONAL ACCESSORIES

The following accessories are available from Keithley for use with the Model 7164.

**Model 7164-KIT** — The Model 7164-KIT is a female bulkhead “D” type connector with solder cups. It mates to the scanner card connector.

**Model 7164-MTC-10** — The Model 7164-MTC-10 is a 10 foot, twisted pair ribbon cable, that is terminated with a male and female 50-pin “D” connector.

**Model 7164-MTR** — The Model 7164-MTR is a female bulkhead “D” type connector with solder cups. It mates to the Model 7164-MTC-10.

# SECTION 2

## Operation

### 2.1 INTRODUCTION

This section contains information on aspects of scanner card operation and is arranged as follows:

- 2.2 Handling Precautions:** Details precautions that should be observed when handling the scanner card to ensure that its performance is not degraded due to contamination.
- 2.3 Equivalent Circuit:** Provides the simplified scanner card circuits for both the Models 7164-D and 7164-M.
- 2.4 Guard/Shield:** Explains the significance of this scanner card terminal and provides examples for making shielded measurements and non-driven guarded measurements.
- 2.5 Multi-Card Configurations:** Explains two basic methods for using multiple cards; common OUTPUT and separate OUTPUTs.
- 2.6 Connections:** Explains the various methods and techniques that can be used to make connections to the scanner card.
- 2.7 Card Installation and Removal:** Covers the basic procedure for installing and removing the card from the scanner mainframe.
- 2.8 Mainframe Control of Scanner Card:** Covers operating aspects specific to the Model 7164. Includes using the card in the 1-pole mode and the matrix mode of operation.



## **2.2 HANDLING PRECAUTIONS**

To maintain high impedance isolation, care should be taken when handling the scanner card to avoid contamination from such foreign materials such as body oils. Such contamination can substantially increase leakage currents, degrading performance.

To avoid possible contamination, always grasp the card by the side edges. Do not touch the edge connectors of the card and do not touch board surfaces or components. When not installed in a mainframe, keep the card in the bag and store in the original packing carton.

Dirt build-up over a period of time is another possible source of contamination. To avoid this problem, operate the mainframe and scanner card only in a clean environment.

If the card should become contaminated, it should be thoroughly cleaned as explained in paragraph 4.2.

## **2.3 EQUIVALENT CIRCUIT**

Figures 2-1 and 2-2 show the equivalent circuits of the Model 7164-D and 7064M. Notice that the only difference between the two circuits is the guarding/shielding of the relay switches. The reed relays of the Model 7164-D have a guard/shield built into them while the mercury relays of the Model 7164-M do not.

For both models, the high (H) and low (L) terminals of each channel are routed through a two-pole, Form A (normally open) relay switch. When a relay is energized, the signal connected to that channel is routed to the output. For most applications, only one channel is connected to the output at one time. However, multiple channels can be connected to the output simultaneously and is explained in paragraph 2.8.

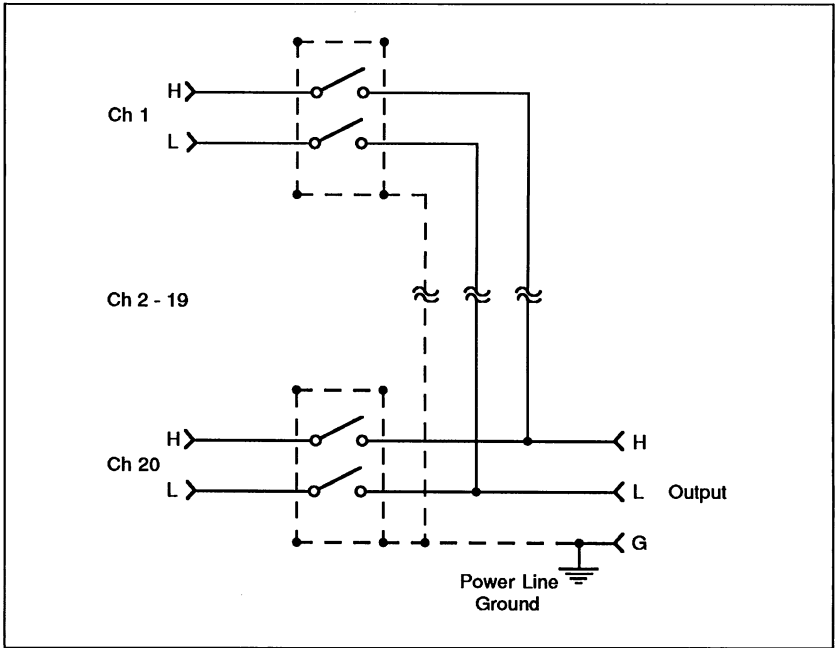

**Figure 2-1. Model 7164 Simplified Schematic**

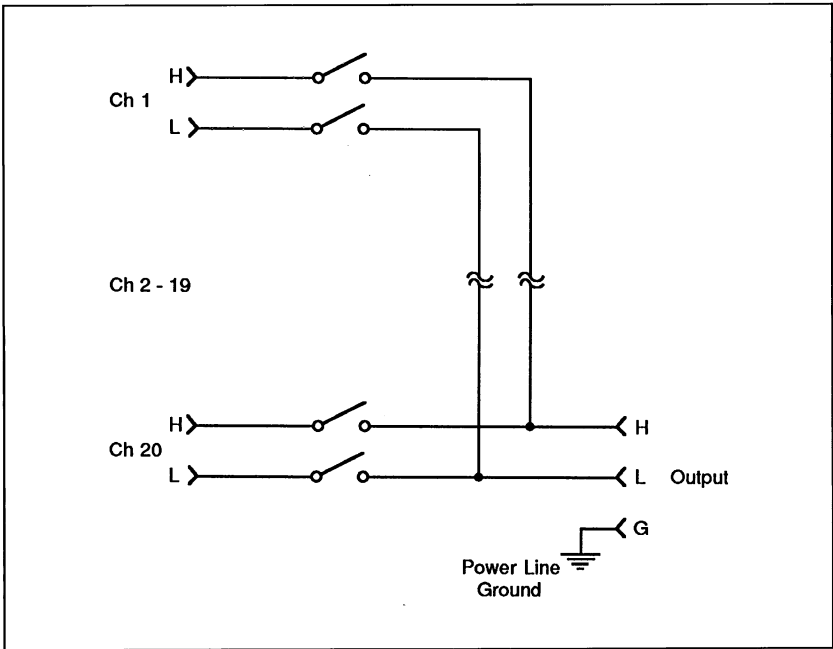

**Figure 2-2. Model 7164-M Simplified Schematic**

## 2.4 SHIELD (G)

When installed in a Model 705 or 706 mainframe, the shield of the scanner card is electrically connected to power line ground. Figure 2-3 shows an example of a shielded measurement configuration. The shield is connected to signal low and extends to the DUT and the voltmeter to help eliminate interference from nearby electric fields. Notice that the DUT end of the shield is not connected to low in order to avoid a ground loop. Figure 2-4 shows an example of a measurement configuration using a floating shield. Circuit low is not connected to power line ground. Notice that in both Figures 2-3 and 2-4, the shield is connected to power line ground at only one point in order to avoid ground loops.

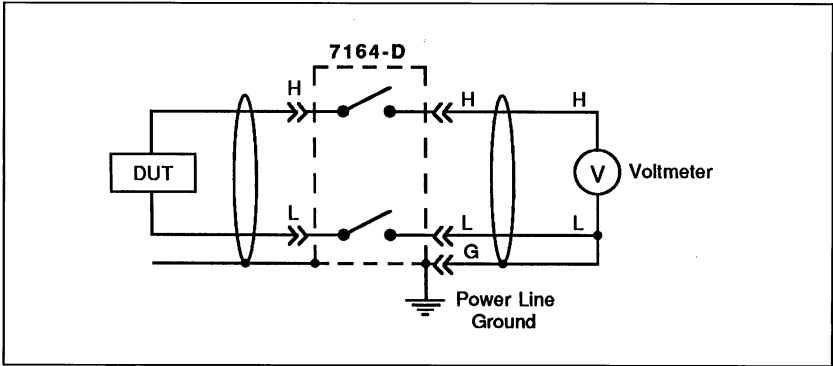

**Figure 2-3. Shielded Measurement**

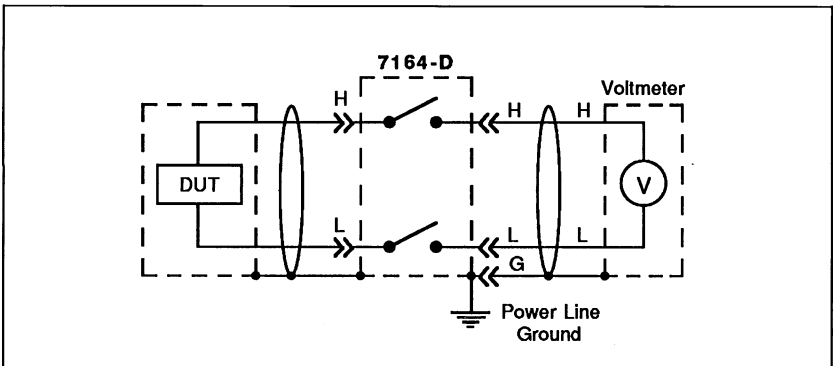

**Figure 2-4. Shielded Measurement (Floating)**

## 2.5 MULTI-CARD CONFIGURATIONS

Typically, multi-card systems are configured by connecting the OUTPUTS of all the scanner cards together. An example of this type of configuration is shown in Figure 2-5, which connects the OUTPUTS of a three-card system together. This common output system allows a single piece of equipment to source or measure all 60 channels.

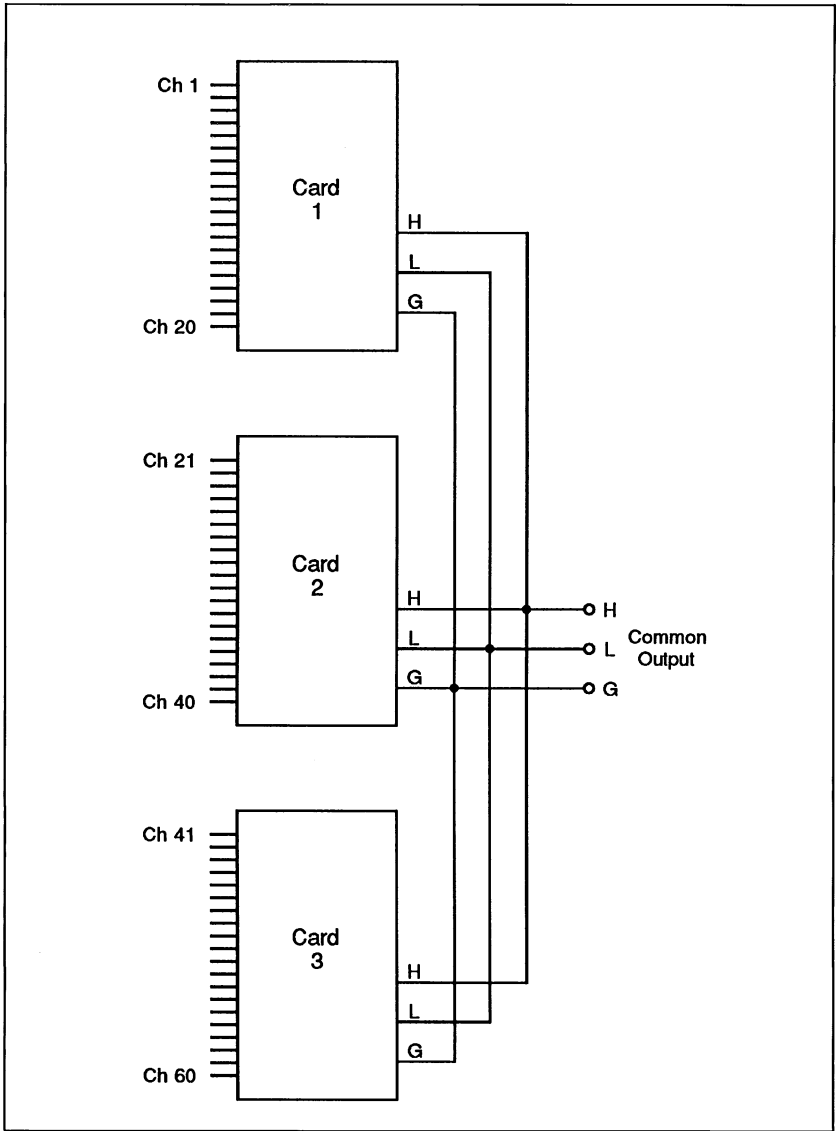

**Figure 2-5. Common Output Configuration**

Another possible way to configure a multi-channel system is with separate outputs. Figure 2-6 shows a two-card system with separate outputs. With this type of configuration, more than one test system can be controlled by the master mainframe.

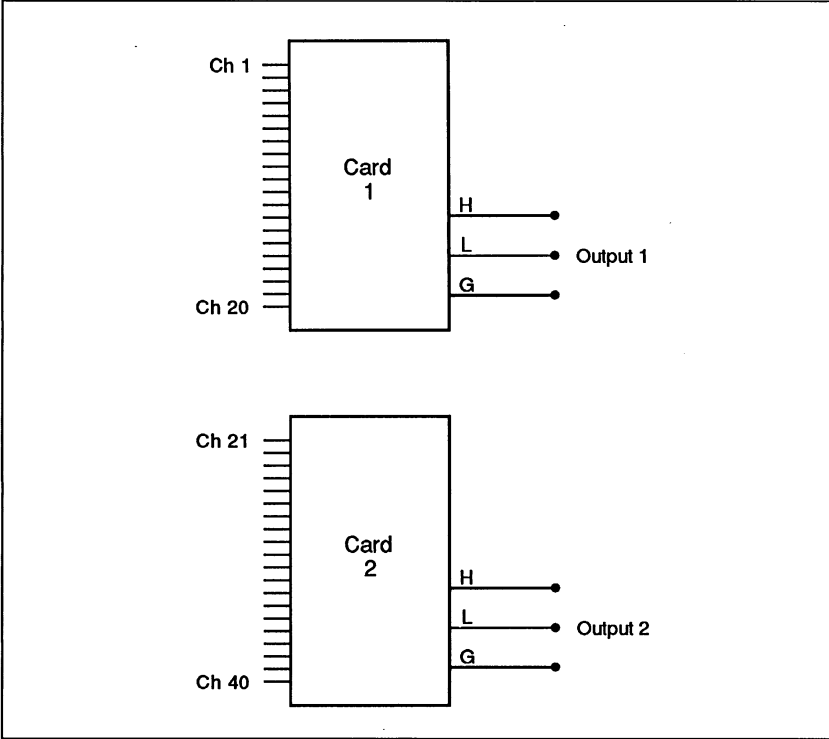

**Figure 2-6. Separate Outputs Configuration**

## 2.6 CONNECTIONS

### CAUTION

**Contamination will degrade the performance of the scanner card. To avoid contamination, always grasp the card by the side edges. Do not touch the board surfaces or components.**

Figure 2-7 shows the male “D” connector of the scanner card. Table 2-1 references scanner card terminals to connector pins. For example, Channel 1 high is connected to pin 1 and Channel 1 low is connected to pin 34.

The connector on the scanner card will mate to either the supplied female “D” connector or to an optional mass terminated cable (Model 7164-MTC).

The following procedure explains how to mate the female “D” connector to the Model 7164.

1. Line up the female “D” connector with the scanner card “D” connector.
2. Firmly push the female “D” connector on the scanner card connector until seated.
3. Secure the connector with the mounting screw.

### NOTE

It may be necessary to loosen the scanner card connector.

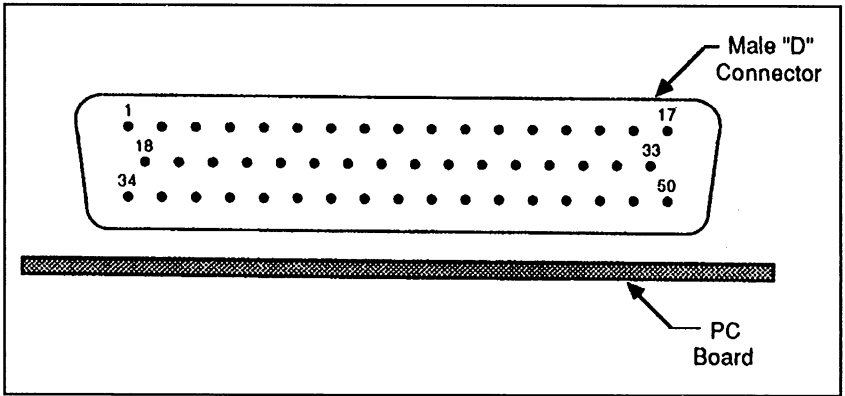

**Figure 2-7. Male “D” Connector on Scanner Card  
(Pin Side Shown)**

### 2.6.1 Connections Using Supplied “D” Connector

As shipped, the Model 7164 has a female “D” connector mated to the scanner card connector. Cabling from instrumentation and DUTs can be soldered directly to this connector. The solder cups of this connector will accommodate up to #18 AWG wire. Figure 2-8 shows the pinout of the female “D” connector and identifies the scanner card terminals. For example, Channel 17 uses pins 47 (high) and 30 (low). Table 2-1 can also be used to identify scanner card terminals.

#### **CAUTION**

**After soldering wires to the female “D” connector, flux will be present on the connector insulator. This contamination will degrade the isolation qualities of the scanner card and, must be cleaned off as explained in paragraph 4-2.**

**After soldering and cleaning the connector, attach the shell.**



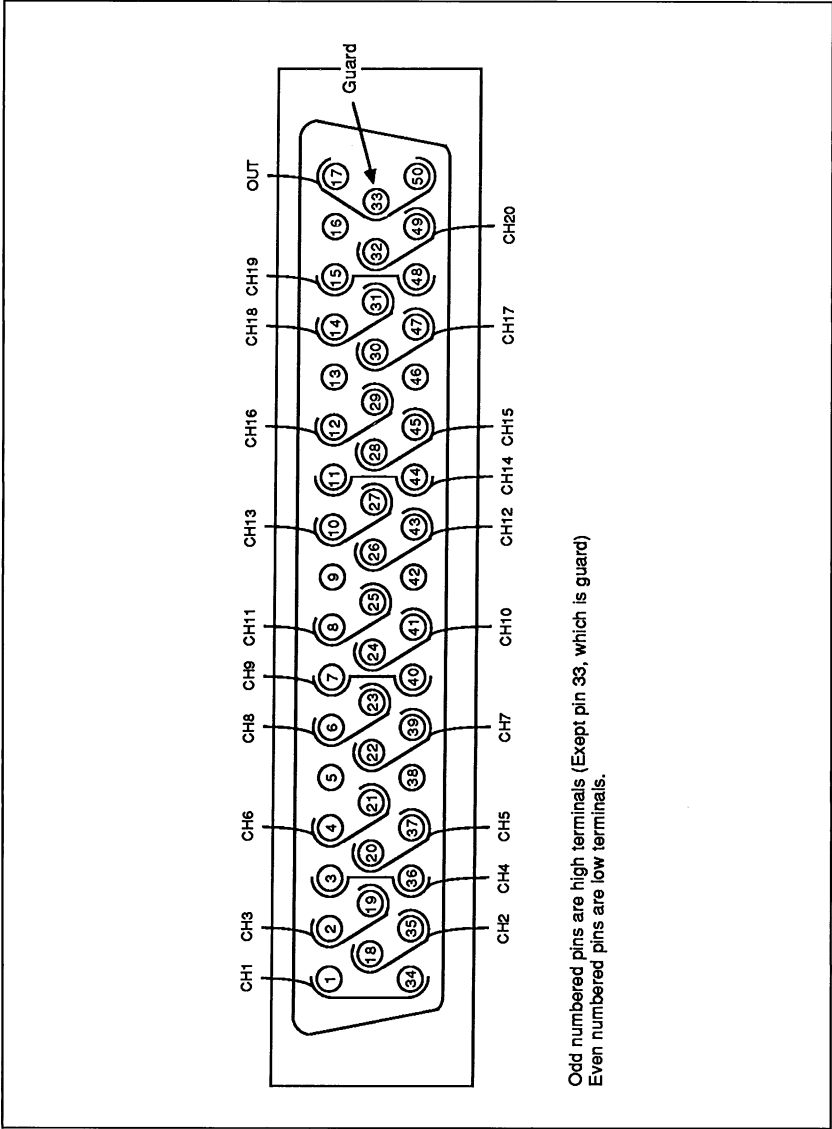

Odd numbered pins are high terminals (Except pin 33, which is guard)  
 Even numbered pins are low terminals.

**Figure 2-8. Female "D" Connector Pin Identification (Solder Cup Side Shown)**

**Table 2-1. “D” Connector Pin Identification**

<b>Scanner Card Channel</b>	<b>Terminal</b>	<b>Connector Pin No.</b>	<b>Scanner Card Channel</b>	<b>Terminal</b>	<b>Connector Pin No.</b>
CH1	H	1	CH11	H	25
	L	34		L	8
CH2	H	35	CH12	H	43
	L	18		L	26
CH3	H	19	CH13	H	27
	L	2		L	10
CH4	H	3	CH14	H	11
	L	36		L	44
CH5	H	37	CH15	H	45
	L	20		L	28
CH6	H	21	CH16	H	29
	L	4		L	12
CH7	H	39	CH17	H	47
	L	22		L	30
CH8	H	23	CH18	H	31
	L	6		L	14
CH9	H	7	CH19	H	15
	L	40		L	48
CH10	H	41	CH20	H	49
	L	24		L	32
Output	H	17	Connector Pins not used: 5, 9, 13, 16, 38, 42, 46		
	L	50			
	G	33			

## 2.6.2 Connections Using Model 7164-MTC Cable

The Keithley Model 7164-MTC (see Figure 2-9) is a 50-conductor, 10-foot cable assembly terminated with a female “D” connector on one end and a male “D” connector on the other end.

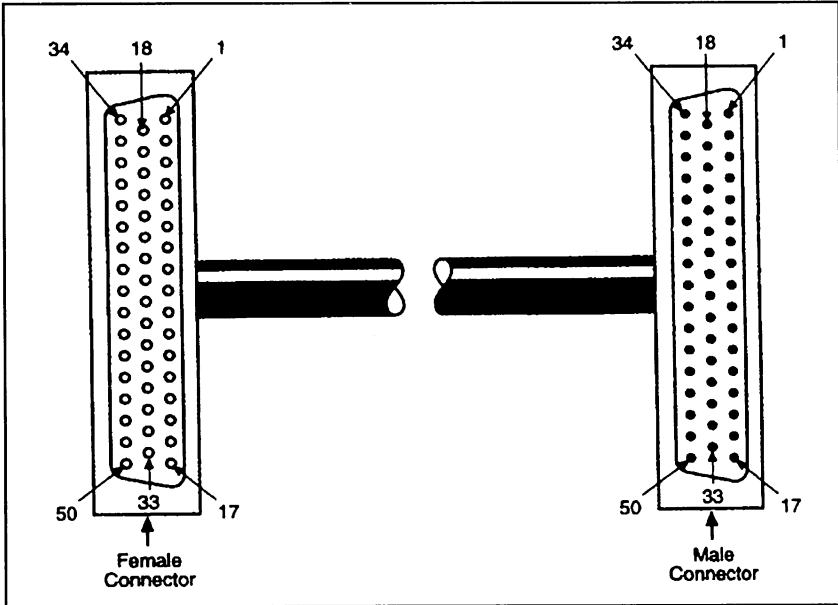

Figure 2-9. Model 7164-MTC

If the cable is going to be used as is, the female end of the cable will mate to the “D” connector on the scanner card, and the male end will mate to the supplied female “D” connector. In this situation, the supplied female “D” connector becomes part of the user’s test fixture with instrumentation and DUTs soldered directly to it. Figure 2-8 identifies the scanner card terminals. Remember, the supplied connector must be cleaned after making solder connections to it (see paragraph 4-2).

Another way to use the cable is to remove the male connector (by cutting the cable). In this situation, the female end of the cable is mated to the scanner card, while the unterminated end is hard-wired to instrumentation and the DUT. Table 2-2 provides scanner card terminal identification for the cable. For example, low (L) and high (H) of Channel 7 are located at conductors 15 and 16 of the cable, respectively. When the destination of the output is located away from the destination of the channels, remove the output portion of the cable from the rest of the cable. Note that conductor #47, which is unused, is included with the output because it is physically twisted around conductor #48, which is output guard.

To make shorter cables, additional connectors are needed. A vendor source for these connectors is T&B Ansley. The Ansley part number for the male connector is 609-50PM and for the female connector is 609-50SM. Shorter cables may be necessary in applications where path resistance is critical. When used as is, each conductor of the 10-foot Model 7164-MTC cable adds approximately 675m $\Omega$  to the “contact resistance” specification of the scanner card.

**Table 2-2. Model 7164-MTC Conductor Identification**

Scanner Card Channel	Terminal	Cable Conductor Number	Scanner Card Channel	Terminal	Cable Conductor Number
CH1	L	1	CH11	L	23
	H	2		H	24
CH2	L	3	CH12	L	27
	H	4		H	28
CH3	L	5	CH13	L	29
	H	6		H	30
CH4	L	7	CH14	L	31
	H	8		H	32
CH5	L	9	CH15	L	33
	H	10		H	34
CH6	L	11	CH16	L	35
	H	12		H	36
CH7	L	15	CH17	L	39
	H	16		H	40
CH8	L	17	CH18	L	41
	H	18		H	42
CH9	L	19	CH19	L	43
	H	20		H	44
CH10	L	21	CH20	L	45
	H	22		H	46
Output	G	48	Cable Conductors not used: 13, 14, 25, 26, 37, 38, 47		
	L	49			
	H	50			

### 2.6.3 Shielded Cables

There are several shielded, unterminated cables available from Spectra-Strip that can be used in applications where maximum shielding is necessary. Male and female “D” type connectors can be attached to these cables in the same manner that they are attached to the Model 7164-MTC. Two of these available cables are described as follows:

**Twist “N” Flat jacketed cable with aluminum/mylar shield (Spectra-Strip P/N 843-152-2831-050)** — This cable is surrounded by a shield that has two drain wires, and is encased in an insulated jacket.

**Spectra-Strip Round Twist “N” Flat jacketed shielded cable (Spectra-Strip P/N 843-159-2832-050)** — This cable combines the features of a round cable and the mass termination capabilities of a flat cable which allows “D” type connectors to be easily attached. This cable uses a foil/braid shield and is encased in an insulated jacket.

## 2.7 CARD INSTALLATION AND REMOVAL

The following procedures explain how to install and remove the Model 7164 scanner card from the Models 705 and 706 scanner mainframes.

### **WARNING**

**To prevent electrical shock which could result in injury or death, turn off the scanner power and disconnect the line cord before installing or removing scanner cards.**

### **CAUTION**

**Contamination will degrade the performance of the scanner card. To avoid contamination, always grasp the card by the side edges. Do not touch the board surfaces or components.**

## 2.7.1 Scanner Card Installation

Perform the following procedure to install the Model 7164 scanner card in either the Model 705 or 706 mainframe. Refer to Figure 2-10 to install the card in the Model 705 and refer to Figure 2-11 to install the card in the Model 706.

1. Slide the card into the desired slot as shown in the appropriate illustration. Make sure the card edges of the board are properly aligned with the grooves in the receptacle.
2. Once the card is almost all the way in the slot, and you encounter resistance, push firmly on the edge of the card to seat it in the edge connector.
3. Once the card is fully seated, lock the card in place by placing the latches in the locked position.

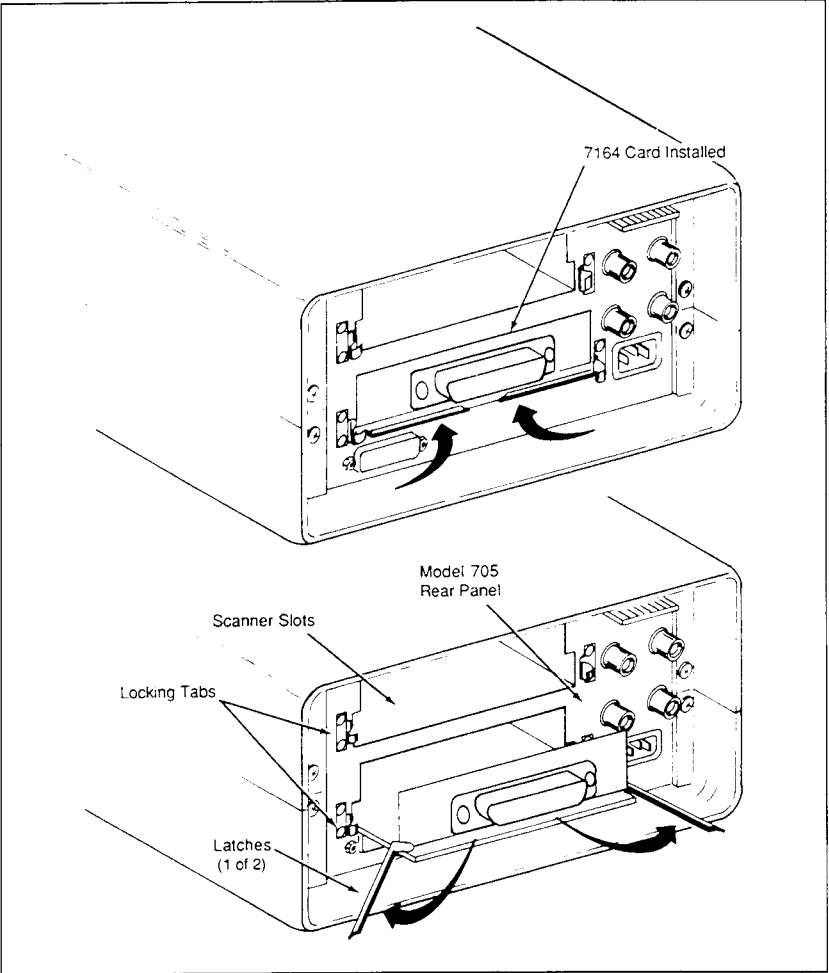

Figure 2-10. Card Installation in Model 705



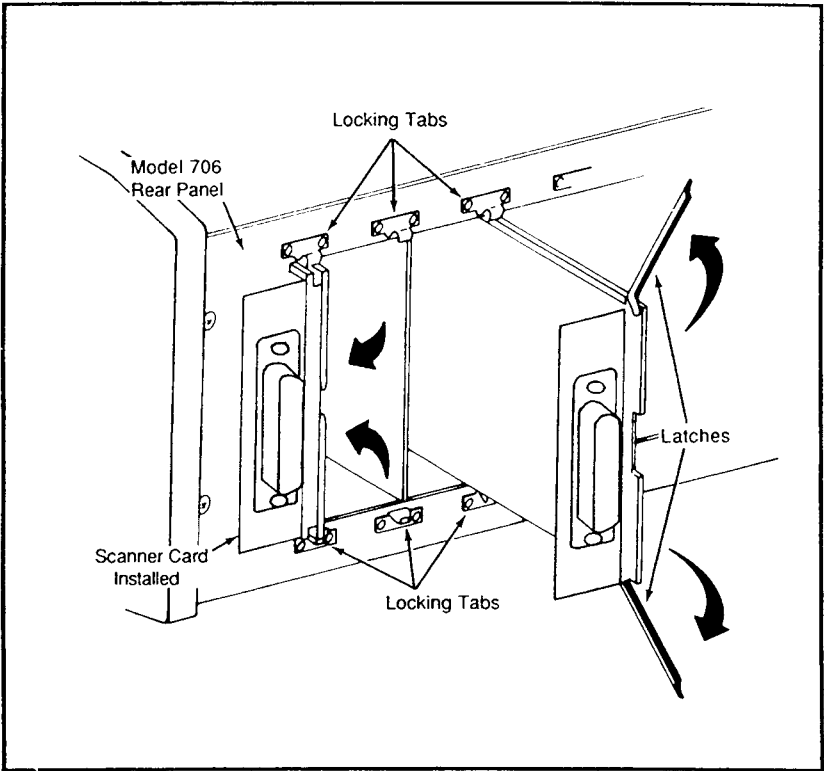

Figure 2-11. Card Installation in Model 706

## **2.7.2 Scanner Card Removal**

To remove the scanner card, first unlock it by pulling the latches outward, then grasp the end of the card at the edges, and pull the card out of the scanner mainframe.

## **2.8 MAINFRAME CONTROL OF SCANNER CARD**

Detailed information to program the Model 705 or 706 scanners is contained in their respective instruction manuals. The following paragraphs provide the information specific to the Model 7164.

The Model 7164 is designed to operate in the 1-pole mode of the scanner mainframe. It will also operate in the matrix mode, but two crosspoints must be closed to close one Model 7164 channel.

### **2.8.1 1-Pole Mode**

The easiest way to control the scanner card is with the mainframe scanner in the 1-pole mode. In this mode, the displayed channel number on the mainframe display corresponds to the scanner card channel under control. Keep in mind that scanner card channel numbers are determined by the slot that the card is installed in. For example, with a Model 7164 installed in the bottom slot (Card 2) of a Model 705, the 20 scanner card channels are assigned channel numbers 21 through 40. Table 2-3 summarizes 1-pole mode scanner card channel assignments for a Model 7164 installed in the first slot of a Model 705 or 706.

**Table 2-3. Channel Assignments\***

7064 Channel	1-Pole Mode		Matrix Mode Crosspoints			
	706	705	706		705	
CH1	001	01	0011	0023	011	023
CH2	002	02	0011	0013	011	013
CH3	003	03	0021	0023	021	023
CH4	004	04	0021	0013	021	013
CH5	005	05	0031	0023	031	023
CH6	006	06	0031	0013	031	013
CH7	007	07	0041	0023	041	023
CH8	008	08	0041	0013	041	013
CH9	009	09	0051	0023	051	023
CH10	010	10	0051	0013	051	013
CH11	011	11	0012	0023	012	023
CH12	012	12	0012	0013	012	013
CH13	013	13	0022	0023	022	023
CH14	014	14	0022	0013	022	013
CH15	015	15	0032	0023	032	023
CH16	016	16	0032	0013	032	013
CH17	017	17	0042	0023	042	023
CH18	018	18	0042	0013	042	013
CH19	019	19	0052	0023	052	023
CH20	020	20	0052	0013	052	013

\*For slot 1 of mainframe.

## 2.8.2 Matrix Mode

Scanner card channels can be manually controlled with the scanner mainframe in the matrix mode of operation. In this mode, two matrix crosspoints must be accessed (closed) from the mainframe in order to close a scanner card channel. The major disadvantages of this mode are that the scanner cannot scan and the channel under control is not obvious from the mainframe display.

Table 2-3 lists the matrix mode crosspoints that must be closed in order to close the channels of a scanner card installed in the first slot of a Model 705 or 706. For example, to close channel 5 of a scanner card installed in slot 1 of a Model 706, scanner crosspoints 0031 and 0023 must be closed.

**2.8.3 Multi-Channel Systems**

Additional channels are available using additional scanner cards. The Model 705 has two card slots. Thus, using one Model 705, 40 channels could be configured. With the maximum of five Model 705s daisy chained, 200 channels could be configured. The Model 706 has 10 card slots. Thus, using one Model 706, 200 channels could be configured. With the maximum of five Model 706s daisy chained, 1000 channels could be configured.

**NOTE**

Refer to the mainframe’s instruction manual for information concerning daisy chain operation.

Scanner card channel assignments for up to five mainframes are shown in Tables 2-4 and 2-5. For matrix mode operation, Tables 2-6 and 2-7 are used to determine crosspoint assignments. The following example will show how to determine which crosspoints will close channel 370.

**Table 2-4. Model 705 Channel Assignments**

Card#	Master	Slave #1	Slave #2	Slave #3	Slave #4
1	01 - 20	41 - 60	81 - 100	121 - 140	161 - 180
2	21 - 40	61 - 80	101 - 120	141 - 160	181 - 200

**Table 2-5. Model 706 Channel Assignments**

<b>Card#</b>	<b>Master</b>	<b>Slave #1</b>	<b>Slave #2</b>	<b>Slave #3</b>	<b>Slave #4</b>
1	001 - 020	201 - 220	401 - 420	601 - 620	801 - 820
2	021 - 040	221 - 240	421 - 440	621 - 640	821 - 840
3	041 - 060	241 - 260	441 - 460	641 - 660	841 - 860
4	061 - 080	261 - 280	461 - 480	661 - 680	861 - 880
5	081 - 100	281 - 300	481 - 500	681 - 700	881 - 900
6	101 - 120	301 - 320	501 - 520	701 - 720	901 - 920
7	121 - 140	321 - 340	521 - 540	721 - 740	921 - 940
8	141 - 160	341 - 360	541 - 560	741 - 760	941 - 960
9	161 - 180	361 - 380	561 - 580	761 - 780	961 - 980
10	181 - 200	381 - 400	581 - 600	781 - 800	981 - 1000

**Table 2-6. Model 705 Matrix Mode Crosspoint Assignments\***

<b>Card#</b>	<b>Master</b>	<b>Slave #1</b>	<b>Slave #2</b>	<b>Slave #3</b>	<b>Slave #4</b>
1	0	+100	+200	+300	+400
2	+50	+150	+250	+350	+450

\*Crosspoint assignments are determined by adding the values in this table to the crosspoint assignment values in Table 2-3.

Example: To close channel 115, which is the 15th channel of card #2 in slave #2, crosspoints 282 (032 + 250) and 273 (023 + 250) would have to be closed.

**Table 2-7. Model 706 Matrix Mode Crosspoint Assignments\***

Card#	Master	Slave #1	Slave #2	Slave #3	Slave #4
1	0	+500	+1000	+1500	+2000
2	+50	+550	+1050	+1550	+2050
3	+100	+600	+1100	+1600	+2100
4	+150	+650	+1150	+1650	+2150
5	+200	+700	+1200	+1700	+2200
6	+250	+750	+1250	+1750	+2250
7	+300	+800	+1300	+1800	+2300
8	+350	+850	+1350	+1850	+2350
9	+400	+900	+1400	+1900	+2400
10	+450	+950	+1450	+1950	+2450

\*Crosspoint assignments are determined by adding the values in this table to the crosspoint assignment values in Table 2-3.

Example: To close channel 685, which is the 5th channel of card #5 in slave #3, crosspoints 1731 (0031 + 1700) and 1723 (0023 + 1700) would have to be closed.

Example: Determine crosspoints required to close channel 370.

Step 1 — From Table 2-5 it can be determined that channel 370 is the 10th channel of card #9 in slave #1.

Step 2 — From Table 2-3, the crosspoint values for channel 10 are 0051 and 0013.

Step 3 — From Table 2-7, the “add factor” for card #9 in slave #1 is +900.

Step 4 — To determine the two crosspoints, add +900 to the values 0051 and 0013. Thus, crosspoints 0951 and 0913 must be closed in order to close channel 370.

## 2.8.4 Scanner Switching Control

The Models 705 and 706 operate on a “break-before-make” basis when scanning. A delay of 1msec occurs between the time the current channel opens until the next channel closes to ensure that no two channels are connected together.

When switching channels manually, however, it is possible to have two or more channels on simultaneously. In this situation, it is important that the potential between channels does not exceed the maximum signal level of the Model 7164. Multiple channel closures can only be done within odd or even channel groups. Otherwise, other unwanted channels may close. For example, closing channels 2 (even) and 5 (odd) will also cause channels 1 and 6 to close.

## 2.8.5 Reactive Loads

Since reactive loads can cause excessive currents and voltages, current surge limiting (for capacitive loads) and voltage clamping (for inductive loads) are required to prevent damage to relays and external circuitry.

### Capacitive Loads

The surge current from a capacitive load must be  $<0.5A$  for the Model 7164-D and  $<0.75A$  for the Model 7164-M to protect the relays and circuit board. Figure 2-12 shows typical circuits to limit current surges. Also, consider the maximum load of 10VA for the Model 7164-D and 30VA for the Model 7164-M when determining the current limit. For example, when switching 100V with the Model 7164-D, the current must be limited to:

$$I = VA/V = 10VA/100V = 100mA$$

The current limiting resistor as used in Figure 2-12A would be:

$$R = V/I = 100V/100mA = 1k\Omega @ 10VA$$

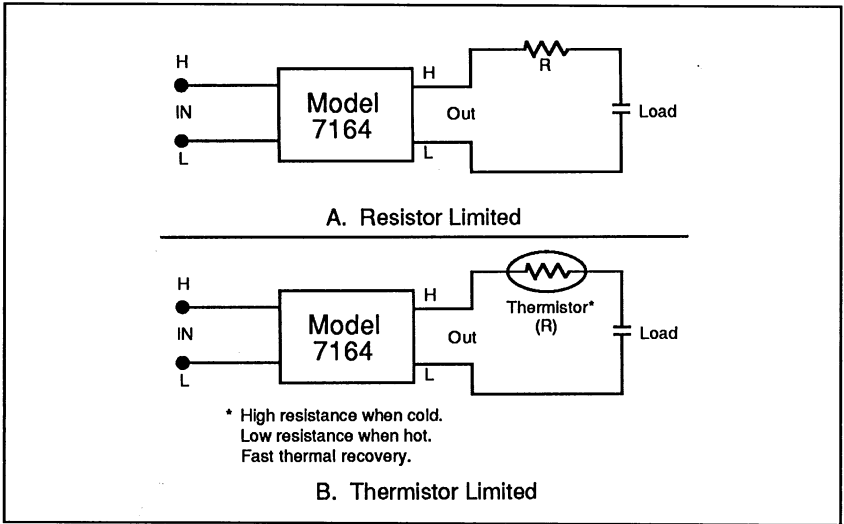

**Figure 2-12. Limiting Capacitance Reaction Current**

### Inductive Loads

Inductive reaction voltage,  $L (di/dt)$ , must be less than 100V. Typical clamping circuits are shown in Figure 2-13. Also, consider the maximum load of 10VA for the Model 7164-D and 30VA for the Model 7164-M when determining the voltage limit. For example, when switching 200mA with the Model 7164-D, the voltage must be limited to:

$$V = VA/I = 10VA/200mA = 50V$$

The value of the voltage clamping resistor used in Figure 2-13A would be:

$$R = V/I = 50V/200mA = 250\Omega @ 10VA$$



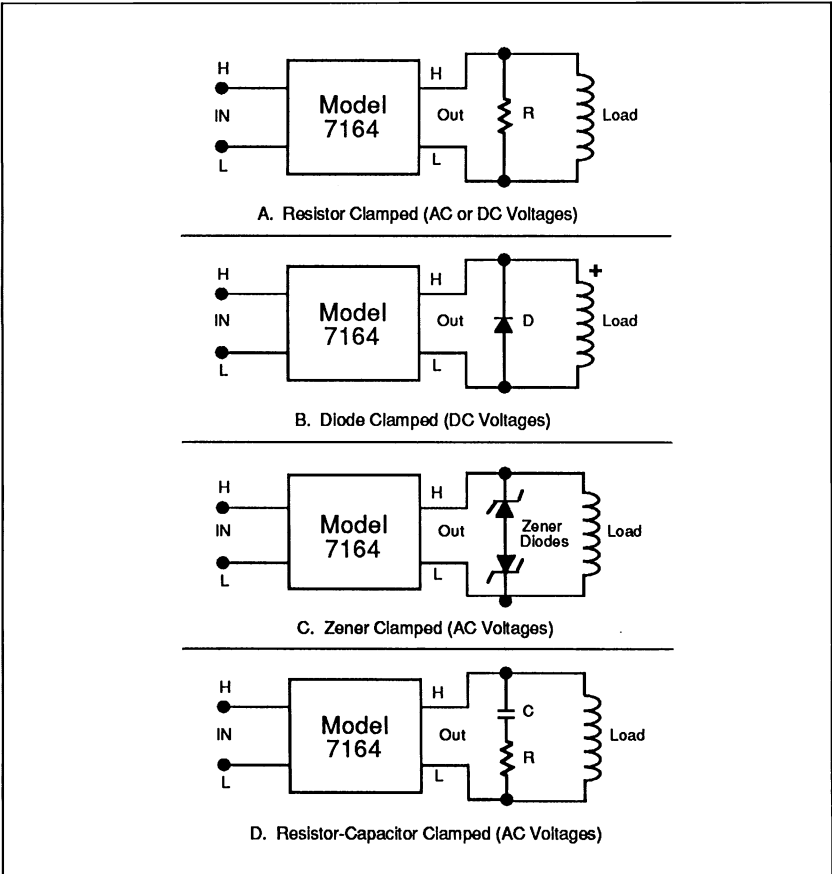

**Figure 2-13. Limiting Inductive Reaction Voltage**

# SECTION 3

## Applications

### 3.1 INTRODUCTION

This section provides some applications for the Model 7164 Scanner Card and is arranged as follows:

**3.2 Life Cycle Testing:** This application tests the durability of DUTs by cycling power on and off.

**3.3 Battery Testing:** This application tests batteries while they are under load to ensure that they maintain an acceptable voltage over a specified period of time.

**3.4 Capacitor Testing:** This application tests capacitors. Capacitors are first charged, and then checked to see that they maintain an acceptable voltage over a specified period of time.

### 3.2 LIFE CYCLE TESTING

Because of its long contact life ( $>2 \times 10^8$  cold closures), the Model 7164-M is ideal for life cycle testing of devices. Many electrical devices are stressed most when they are first powered on, due to the initial surge current. Thus, a device would have to survive a certain number of power cycles to be considered successful in the field. As a simple example, a light bulb can be turned on and off typically 250 times during its lifetime. A sampling from a production run of light bulbs can be life cycled to determine the quality of the entire lot.

Figure 3-1 shows the system configuration for this application. This system only shows one scanner card, but by using 10 cards in five Model

705s, 200 DUTs can be tested, and by using 50 cards in five Model 706s, 1000 DUTs can be tested. This test simply applies power (from the Model 230) to each DUT for a predetermined period of time (scanner dwell time).

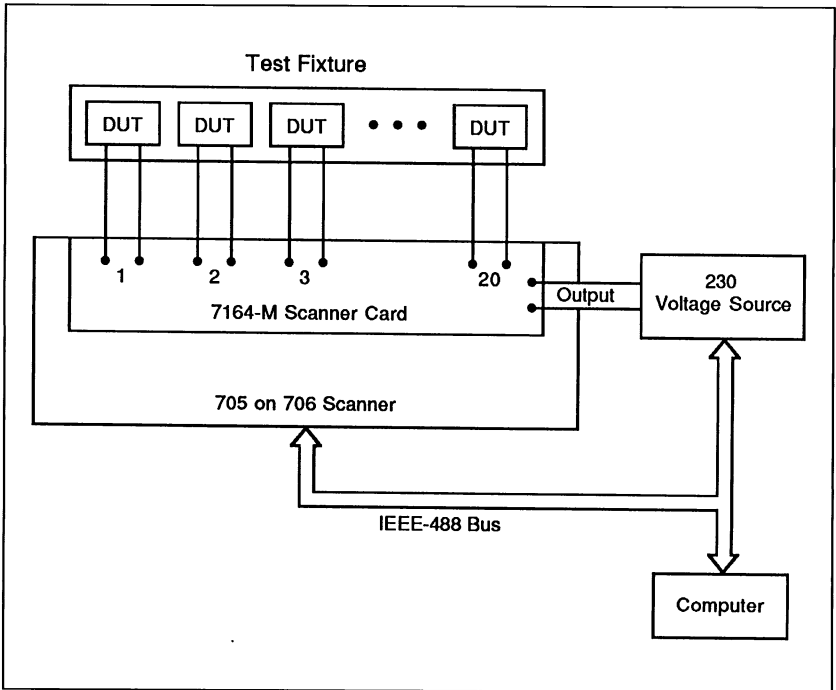

**Figure 3-1. Life Cycle Testing**

This system shows a computer controlling the test over the IEEE-488 bus, but is not absolutely necessary. The scanner could be set to scan continuously. In this situation, the test would have to be stopped manually after the required number of test scans are completed.

With the use of a computer, the test could be terminated automatically after the required number of scans. Also, the computer can be programmed to place the voltage source in standby before closing and opening each channel. Cold switching the scanner card increases its relay contact life significantly ( $2 \times 10^8$  cold closures versus  $2 \times 10^7$  hot closures).

An important consideration in this test is the power sourced through the card. The maximum signal level for the card is 100V, 0.75A, 30VA. Exceeding any of these limits could damage the card. For high power DUTs, it is recommended that power be delivered from a separate power source using external relays that are energized by the Model 230 through the scanner card. The Digital I/O Port of the Model 230 can output +5VDC to drive a TTL load.

### **3.3 BATTERY TESTING**

In this application, the performance of batteries under load can be tested. Figure 3-2 shows the system configuration for this application. This system only shows one scanner card, but by using 10 cards in five Model 705s, 200 batteries can be tested, and by using 50 cards in five Model 706s, 1000 batteries can be tested.

The purpose of this test is to ensure that the batteries will maintain an acceptable voltage level while discharging through a load over a designated period of time.

This type of a test is best controlled by a computer so that data can be recorded and evaluated. The computer program for this test would perform a series of single scans. During each scan, the voltage of each battery would be recorded. Any battery that falls below an acceptable voltage limit would be flagged as defective.

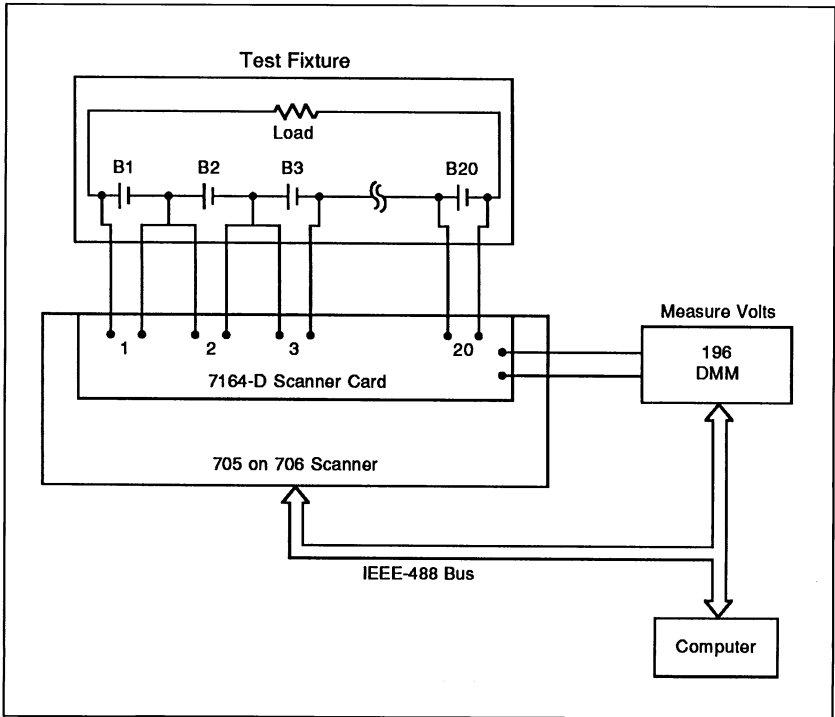

**Figure 3-2. Battery Testing**

### 3.4 CAPACITOR TESTING

In this application, capacitors are tested to ensure that they maintain an acceptable charge level over a designated period of time. Figure 3-3 shows the system configuration for this application.

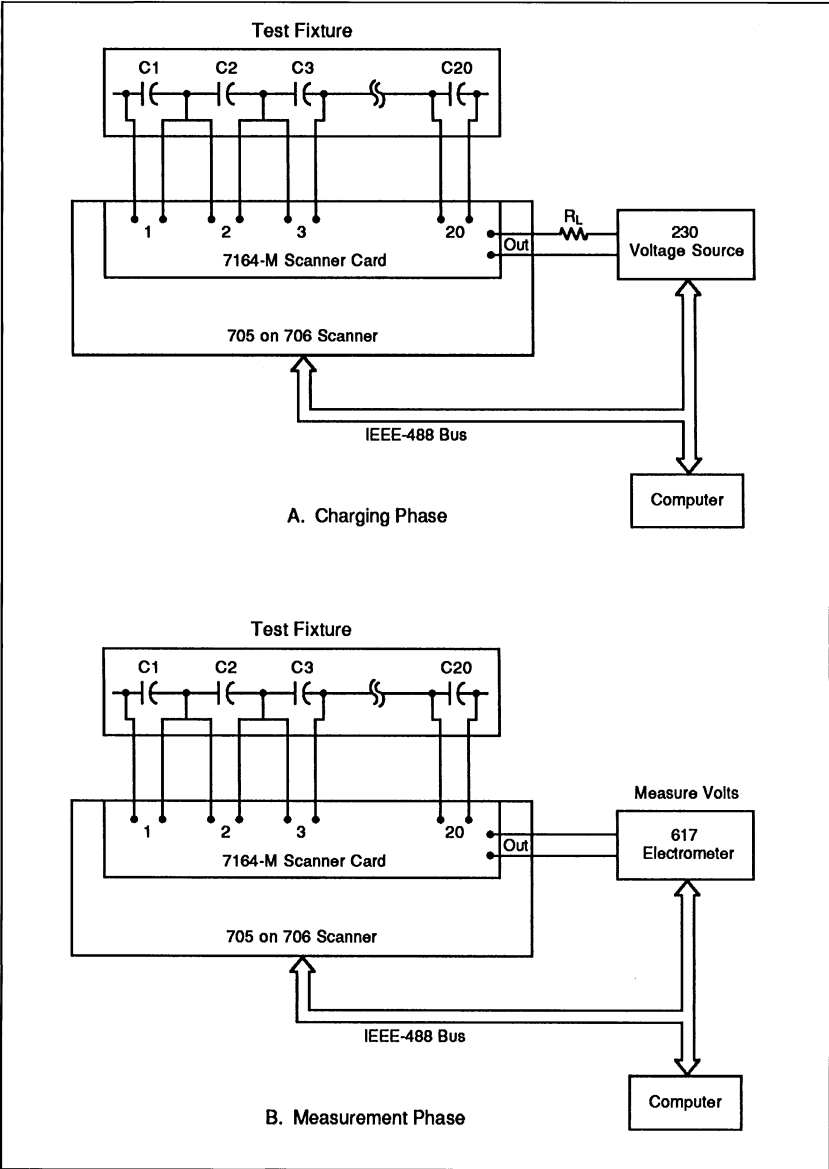

**Figure 3-3. Capacitor Testing**

This system only shows one scanner card, but by using 10 cards in five Model 705s, 200 batteries can be tested, and by using 50 cards in five Model 706s, 1000 batteries can be tested.

This test system is broken down into two phases; the charge phase and the measurement phase. During the charge phase, a single scan is performed to charge each capacitor with the Model 230 voltage source. Resistor  $R_L$  provides current limit to protect the card. The value of  $R_L$  is dependent on the charging voltage. Then, using Ohms Law,  $R_L = V / I$ . For example, the maximum allowable current for the Model 7164-D is 0.5A. With a charging voltage of 25V, the minimum value of  $R_L$  would be calculated as follows:

$$\begin{aligned} R_L &= V / I \\ &= 25V / 0.5A \\ &= 50\Omega \end{aligned}$$

During the scan, the dwell time on each channel would have to be long enough for the capacitor to fully charge. The required dwell time is dependent on the value of the capacitor and the value of  $R_L$ . A capacitor charges in five time constants. Thus, the dwell time required to charge a capacitor is calculated as follows:

$$5\tau = 5(R \times C)$$

where;  $\tau = \text{Tau (time constant)}$

For example, the dwell time required to charge a  $100\mu\text{F}$  capacitor through a  $50\Omega$  current limiting resistor is calculated as follows:

$$\begin{aligned} 5\tau &= 5(50 \times 10^{-4}) \\ &= 25\text{msec} \end{aligned}$$

Thus, the minimum programmed dwell time would have to be 25msec to fully charge each capacitor.

During the measurement phase, a single scan is performed to measure the charged voltage (using the Model 617 Electrometer) of each capacitor. An electrometer is used because of its high input impedance. Capacitor discharge through the electrometer is negligible. Using a computer to control the test allows the data to be recorded and analyzed. Defective capacitors that do not hold an acceptable charge could be flagged by the computer.

An important consideration to take into account during this test is capacitor discharge across the PC board of the Model 7164. The isolation resistance of the scanner card is  $>10^9\Omega$ . Thus, the time it takes for the capacitor to discharge through the board can be calculated as follows:

$$\text{Discharge Time} = 5\tau = 5(C \times 10^9)$$

This discharge factor has to be taken into account when measuring the charge on the capacitor.



# SECTION 4

## Service Information

### 4.1 INTRODUCTION

This section contains information necessary to service the Model 7164 and is arranged as follows:

**4.2 Handling and Cleaning Precautions:** Discusses handling procedures and cleaning methods for the scanner card.

**4.3 Performance Verification:** Covers the procedures necessary to determine if the card is operating properly.

**4.4 Relay Interchangeability:** Discusses the interchangeability of the relays between the Models 7164-D and 7164-M.

### 4.2 HANDLING AND CLEANING PRECAUTIONS

Because of the high impedance circuits on the Model 7164, care should be taken when handling or servicing the card to prevent possible contamination, which could degrade performance. The following precautions should be taken when handling and cleaning the scanner card.

1. Do not store or operate the card in an environment where dust could settle on the circuit board. Use dry nitrogen gas to clean dust off the card if necessary.
2. Handle the card only by the side edges. Do not touch any board surfaces or components associated with the repair. When servicing the card, wear clean, white cotton gloves.
3. If making solder repairs on the circuit board, use a flux that is rosin RMA based. Remove the flux from these areas when the repair is complete. Use Freon<sup>®</sup> TMS or TE, or the equivalent along with plen-

ty of clean cotton swabs to remove the flux. Take care not to spread the flux to other areas of the circuit board. Once the flux has been removed, swab only the repaired area with methanol, then blow dry the board with dry nitrogen gas. If solder connections are made to the female "D" connector, clean the flux off the insulator in the same manner.

4. After cleaning, the card should be placed in a 50°C low humidity environment for several hours.

## **4.3 PERFORMANCE VERIFICATION**

The following paragraphs discuss performance verification procedures for the Models 7164-D and 7164-M, including isolation, contact potential, and path resistance.

The performance verification procedures should be performed with the scanner card installed in the Model 705 or 706 mainframe to protect it from contamination and allow it to operate in its normal environment.

### **CAUTION**

**Contamination will degrade the performance of the scanner card. To avoid contamination, always grasp the card by the side edges. Do not touch the edge connectors of the card, and do not touch the board surfaces or components.**

### **NOTE**

Failure of any performance verification test may indicate that the scanner card is contaminated. See paragraph 4.2 to clean the card.

### **4.3.1 Environmental Conditions**

All verification measurements should be made at an ambient temperature between 18° and 28°C, and at a relative humidity of less than 70%.

### 4.3.2 Recommended Equipment

Table 4-1 summarizes the equipment necessary for performance verification, along with an application for each unit.

**Table 4-1. Verification Equipment**

Description	Model	Specifications	Application
Electrometer	Keithley 617	100nA; 0.25% 100V Source; 0.2%	Isolation
Nanovoltmeter	Keithley 181	2mV; 0.015%	Contact potential
DMM	Keithley 196	300Ω; 0.01%	Path resistance
Female "D" Connector*	Keithley	—	Connections to card

\*One of these connectors is supplied with the Model 7164.

### 4.3.3 Connector Preparation

For the test procedures, a female "D" connector is used to make circuit connections to the scanner card. One of these connectors is supplied with the Model 7164. One end of the connector mates to the "D" connector on the scanner card and the other end has solder cups for external circuit connections.

Prepare a female "D" connector as follows:

1. Using clean #18-24 AWG copper wire, solder in 21 jumpers at the locations shown in Figure 4-1. Each jumper wire should be approximately one inch long.
2. Solder a ½" length of copper wire to pin 33 of the connector.

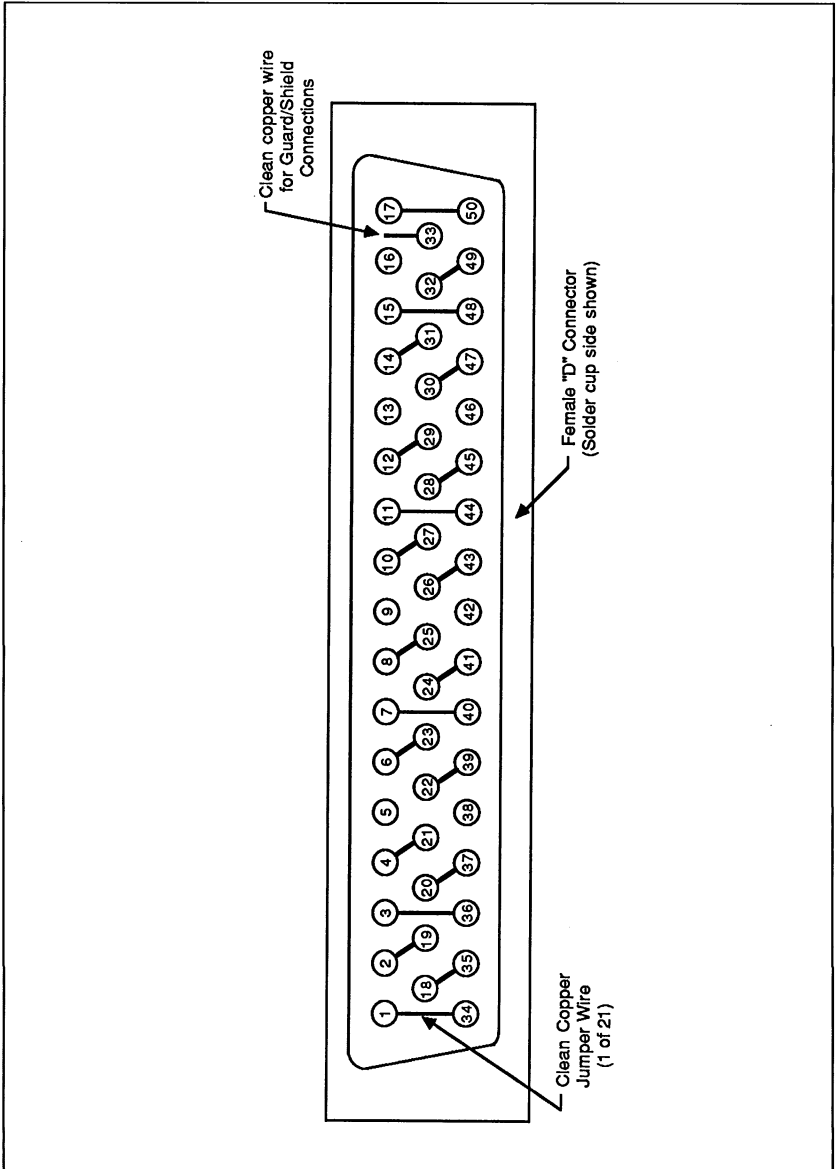

**Figure 4-1. Female Connector Preparation for Performance Verification**

3. Clean the connector as described in paragraph 4-2 to remove solder flux and other contaminants.
4. Separate the soldered wires to prevent them from shorting to one another.
5. Mate the prepared "D" connector to the male "D" connector of the scanner card.

#### **NOTE**

The order that performance verification tests are presented is such that additional soldering to the connector (and subsequent cleaning) is not required. Required connector modifications are accomplished by simply cutting appropriate jumper wires in half.

### **4.3.4 Channel Isolation Tests**

These tests check the resistance (isolation) between two channels. In general, the test is performed by applying a voltage (+100V) across the open channel and the output, and then measuring the leakage current. The isolation resistance is then calculated as  $R = V/I$ . In the following procedure, the Model 617 functions as both a voltage source and a picoammeter. In the V/I function, the Model 617 internally calculates the resistance from the known voltage and measured current levels and displays the resistance value.

Referring to Figure 4-2, perform the following procedure to check channel isolation:

#### **WARNING**

**The following steps use high voltage (100V). Be sure to remove power from the circuit before making connection changes.**

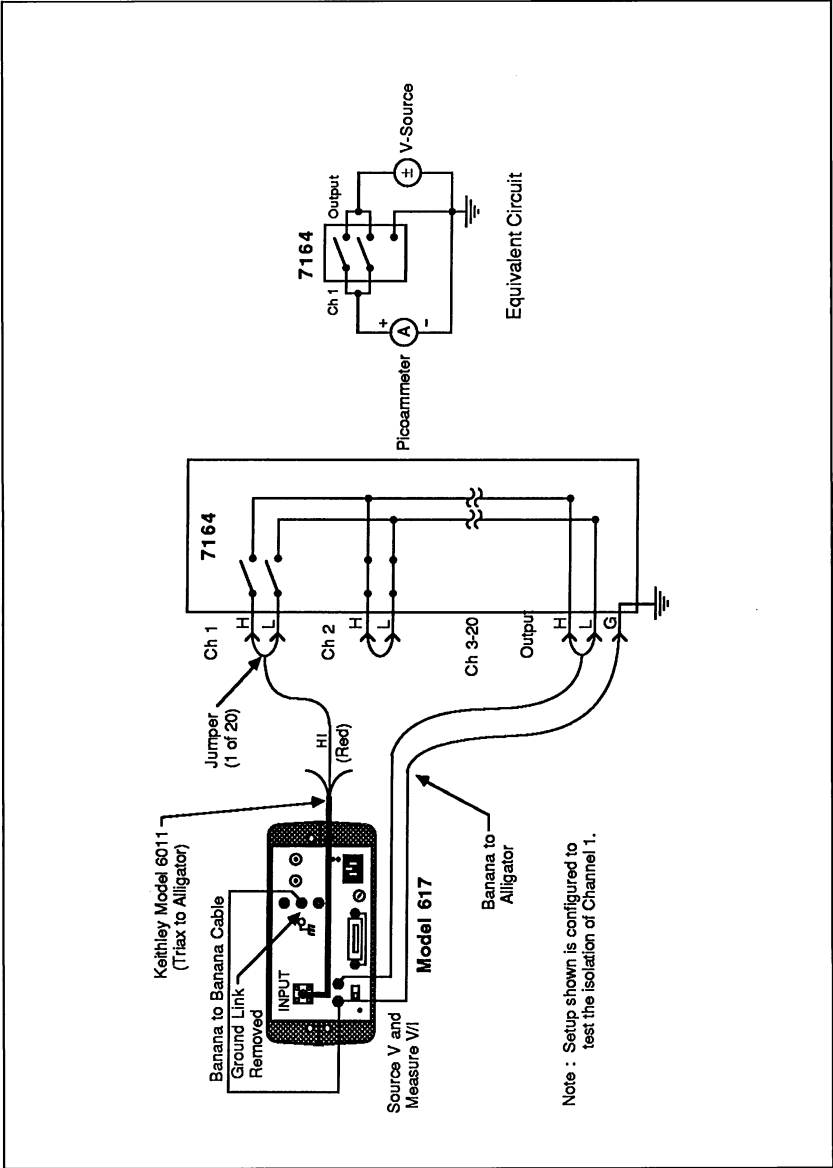

**Figure 4-2. Channel Isolation**

1. Using Figure 4-3 to identify scanner card terminals, connect the Model 617 to the scanner card as shown in Figure 4-2.
2. With the scanner in the step mode, open channel 1 and close the rest of the scanner card channels.
3. On the Model 617, select the 2pA range, and enable ZERO CHECK and ZERO CORRECT in that order. Leave ZERO CORRECT enabled for the entire procedure.
4. On the Model 617, set the voltage source for +100V, and select the 200nA current range. Make sure the voltage source is still in standby.
5. Place the Model 617 in the V/I measurement function by pressing SHIFT OHMS.
6. On the Model 617, disable ZERO CHECK and press OPERATE to source 100V.
7. After allowing the reading on the Model 617 to settle, verify that it is  $>1G\Omega$ .
8. Place the Model 617 in standby and enable ZERO CHECK.
9. Connect the electrometer input HI lead to channel 2 of the scanner card.
10. On the scanner, open channel 2 and close the rest of the scanner card channels.
11. Repeat steps 6 through 8.
12. Repeat the basic procedure in steps 9 through 11 for channels 3 through 20.

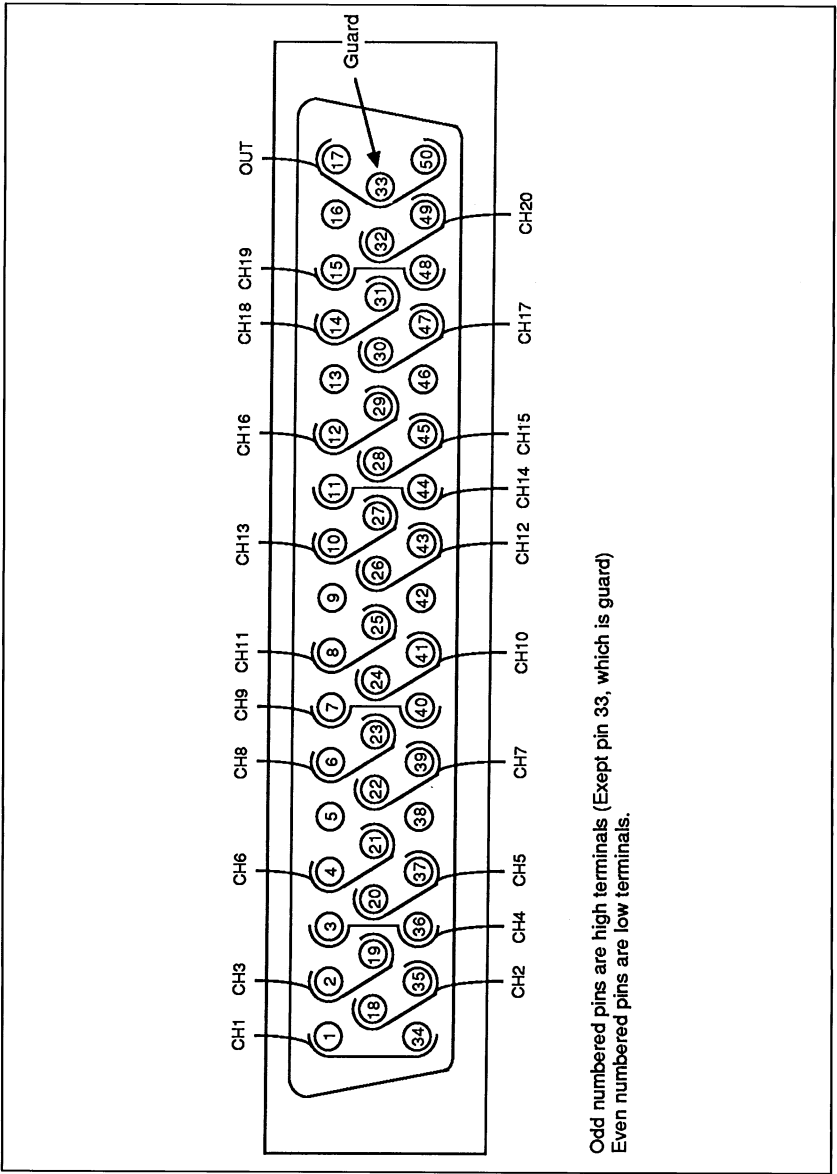

Odd numbered pins are high terminals (Except pin 33, which is guard)  
 Even numbered pins are low terminals.

**Figure 4-3. Female "D" Connector Pin Identification (Solder Cup Side Shown)**



### 4.3.5 Common Mode Input Isolation Tests

These tests check the resistance (isolation) between high/low and shield of every channel. In general, the test is performed by applying a voltage (100V) across the terminals and then measuring the leakage current. The isolation resistance is then calculated as  $R = V/I$ . In the following procedure, the Model 617 functions as a voltage source and an ammeter. In the V/I function, the Model 617 internally calculates the resistance from the known voltage and measured current levels and displays the resistance value.

Referring to Figure 4-4, perform the following procedure to check common mode input isolation:

#### **WARNING**

**The following steps use high voltage (100V). Be sure to remove power from the circuit before making connection changes.**

1. Referring to Figure 4-1, cut the jumper connecting pins 17 to 50 in half.
2. Using Figure 4-3 to identify scanner card terminals, connect the Model 617 to the scanner card as shown in Figure 4-4.
3. With the scanner in the step mode, close channel 1 and open the rest of the scanner card channels.
4. On the Model 617, select the 2pA range, and enable ZERO CHECK and ZERO CORRECT in that order. Leave ZERO CORRECT enabled for the entire procedure.
5. On the Model 617, set the voltage source for +100V, and select the 200nA current range. Make sure the voltage source is still in standby.
6. Place the Model 617 in the V/I measurement function by pressing SHIFT OHMS.
7. On the Model 617, disable ZERO CHECK and press OPERATE to source 100V.
8. After allowing the reading on the Model 617 to settle, verify that it is  $>1G\Omega$ .
9. Place the Model 617 in standby and enable ZERO CHECK.



10. Connect the voltage source output HI lead to channel 2 of the scanner card.
11. On the scanner, close channel 2 and open the rest of the scanner card channels.
12. Repeat steps 7 through 9.
13. Repeat the basic procedure in steps 10 through 12 for channels 3 through 20.

### 4.3.6 Contact Potential Tests

These tests check the EMF generated by each relay contact pair (H and L) for each channel. The tests simply consists of using a nanovoltmeter (Model 181) to measure the contact potential.

Referring to Figure 4-5, perform the following procedure to check contact potential of each channel:

1. Set the Model 181 to the 2mV range, short the input leads and press ZERO to null out internal offset. Leave ZERO enabled for the entire procedure.
2. Using Figure 4-3 to identify scanner card terminals, connect the Model 181 to the scanner card as shown in Figure 4-5.
3. With the scanner in the step mode, close channel 1 and open the rest of the scanner card channels.
4. Verify that the contact potential of this channel is as follows:
  - A. For the Model 7164-D,  $<50\mu\text{V}$ .
  - B. For the Model 7164-M,  $<75\mu\text{V}$ .
5. Repeat the basic procedure in steps 3 and 4 to test the rest of the scanner channels. Make sure that only the channel being tested is closed. The other scanner card channels must be open.

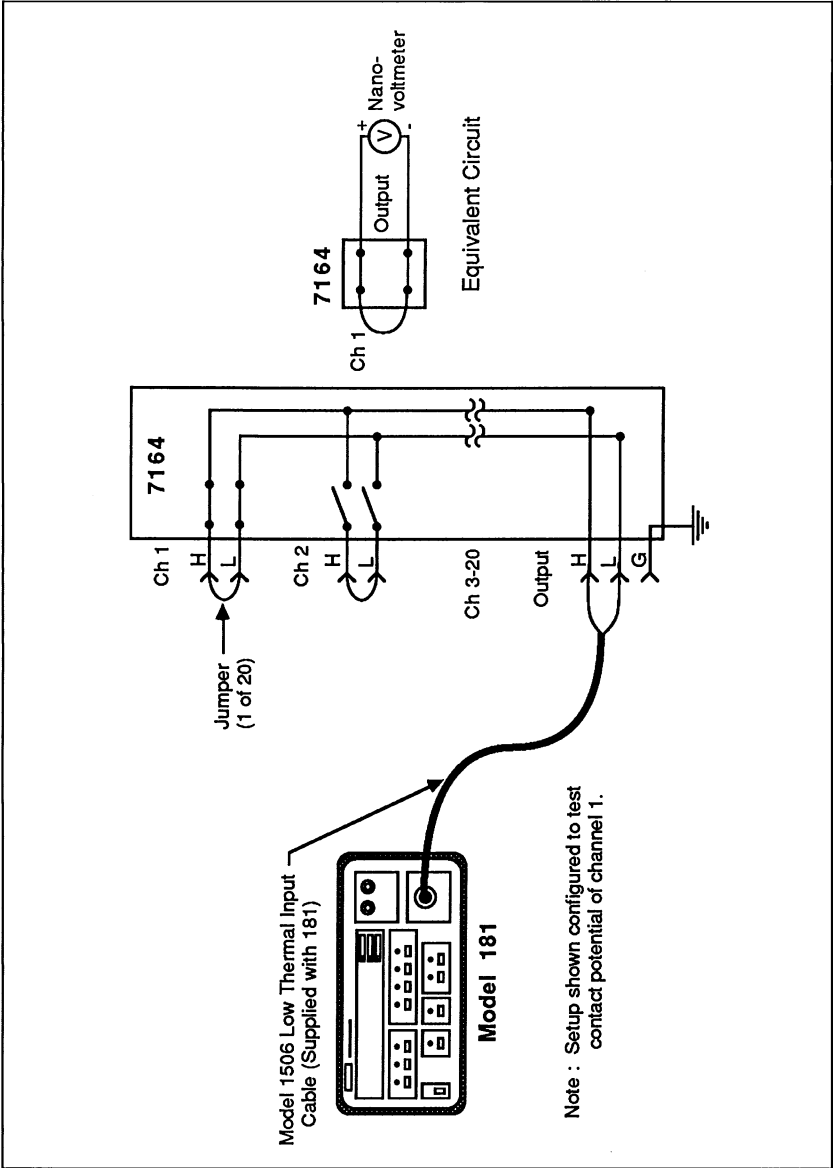
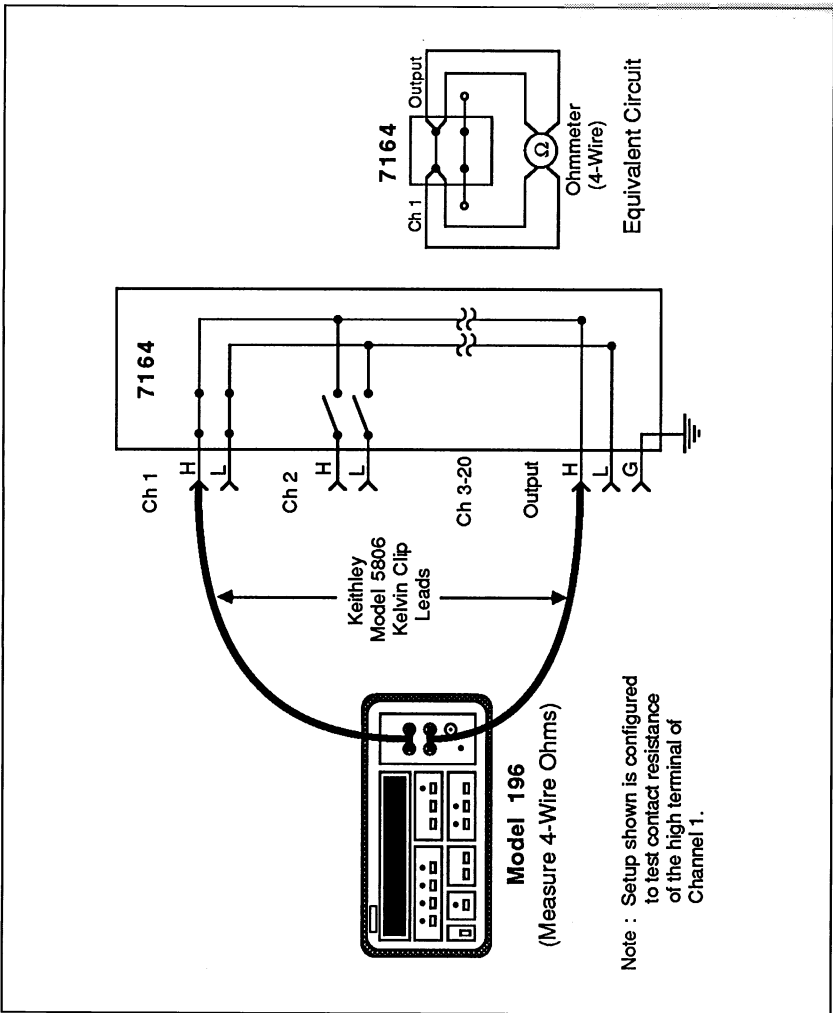

**Figure 4-5. Contact Potential**

### 4.3.7 Path Resistance Tests

Referring to Figure 4-6, perform the following steps to verify that the contacts of each relay are closing properly and the resistance is within specification.

1. Cut all the remaining jumper wires in half. Position each wire such that they do not short to one another.
2. Connect the Kelvin clip leads to the input of the Model 196 as shown in Figure 4-6 and select the  $300\Omega$  range.
3. Short the Kelvin clip leads together and zero the Model 196. Leave zero enabled for the entire test.
4. Using Figure 4-3 to identify scanner card terminals, connect the Model 196 to the scanner card.
5. With the scanner in the step mode, close channel 1. The reading on the Model 196 should be as follows:
  - A. For the Model 7164-D,  $<2\Omega$ .
  - B. For the Model 7164-M,  $<200m\Omega$ .
6. Open channel 1 and verify that the Model 196 indicates an open circuit ( $>300M\Omega$ ).
7. Connect the Model 196 to channel 1 low (L) and output low (L), and repeat steps 5 and 6.
8. Repeat the basic procedure of steps 4 through 7 to test path resistance of high and low of channels 2 through 20.



**Figure 4-6. Path Resistance**

### 4.3.8 Differential Input Isolation Tests

These tests check the resistance (isolation) between the high and low terminals of every scanner card channel. In general, the test is performed by applying a voltage (100V) across the terminals and then measuring the leakage current. The isolation resistance is then calculated as  $R = V/I$ . In the following procedure, the Model 617 functions as a voltage source and an ammeter. In the V/I function, the Model 617 internally calculates the resistance from the known voltage and measured current levels and displays the resistance value.

Referring to Figure 4-7, perform the following procedure to check differential input isolation:

#### **WARNING**

**The following steps use high voltage (100V). Be sure to remove power from the circuit before making connection changes.**

1. Using Figure 4-3 to identify scanner card terminals, connect the Model 617 to the scanner card as shown in Figure 4-7.
2. With the scanner in the step mode, close channel 1 and open the rest of the scanner card channels.
3. On the Model 617, select the 2pA range, and enable ZERO CHECK and ZERO CORRECT in that order. Leave ZERO CORRECT enabled for the entire procedure.
4. On the Model 617, set the voltage source for +100V, and select the 200nA current range. Make sure the voltage source is still in standby.
5. Place the Model 617 in the V/I measurement function by pressing SHIFT OHMS.
6. On the Model 617, disable ZERO CHECK and press OPERATE to source 100V.
7. After allowing the reading on the Model 617 to settle, verify that it is  $>1G\Omega$ .
8. Place the Model 617 in standby and enable ZERO CHECK.
9. Connect the electrometer Input HI lead to channel 2 low (L) of the scanner card, and connect V-Source HI channel 2 high (H).

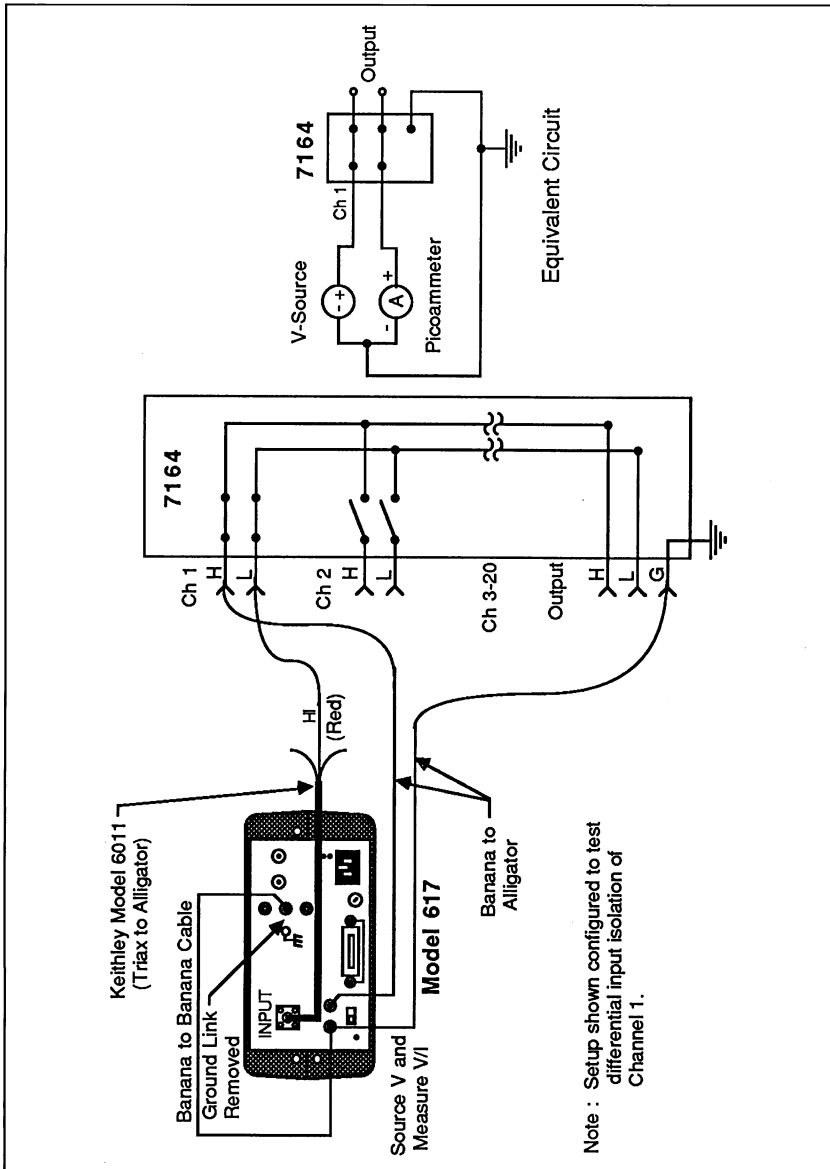

**Figure 4-7. Input Isolation (Differential)**



10. On the scanner, close channel 2 and open the rest of the scanner card channels.
11. Repeat steps 6 through 8.
12. Repeat the basic procedure in steps 9 through 11 for channels 3 through 20.

#### 4.4 RELAY INTERCHANGEABILITY

The only difference between the Model 7164-D and the Model 7164-M is the relays. The Model 7164-D uses dry reed relays while the Model 7164-M uses mercury wetted relays. Mercury wetted relays used on the Model 7164-M can be used as replacement relays on the Model 7164-D and conversely, reed relays used by the Model 7164-D can be used on the Model 7164-M. Table 4-2 lists the specification differences between the two relay types. If a different type relay is installed on the card, it is recommended that a tag be strategically placed to indicate the change.

**Table 4-2. Relay Specification Comparisons**

Specification	Model 7164-D	Model 7164-M
Relay Drive Current	30mA typical	50mA typical
Maximum Signal Level	10VA	30VA
Contact Life (Closures)	1 × 10 <sup>8</sup> (cold) 1 × 10 <sup>7</sup> (max signal)	2 × 10 <sup>8</sup> (cold) 2 × 10 <sup>7</sup> (max signal)
Contact Resistance	< 2Ω	< 200mΩ
Contact Potential	< 50μV	< 75μV

# **SECTION 5**

## **Replaceable Parts**

### **5.1 INTRODUCTION**

This section contains a list of replaceable electrical and mechanical parts for the Model 7164, as well as a component layout drawing and schematic diagram of the matrix card.

### **5.2 PARTS LISTS**

Electrical parts are listed in order of circuit designation in Table 5-1. Table 5-2 summarizes miscellaneous parts.

### **5.3 ORDERING INFORMATION**

To place a parts order, or to obtain information concerning replacement parts, contact your Keithley representative or the factory (see the inside front cover for addresses). When ordering parts, be sure to include the following information:

1. Scanner card model number (7164-D or 7164-M)
2. Card serial number
3. Part description
4. Circuit description, if applicable
5. Keithley part number

## **5.4 FACTORY SERVICE**

If the scanner card is to be returned to Keithley Instruments for repair, perform the following:

1. Complete the service form at the back of this manual and include it with the card.
2. Carefully pack the card in the original packing carton.
3. Write ATTENTION REPAIR DEPT on the shipping label.

Note: Do not return the scanner mainframe with the card.

## **5.5 COMPONENT LAYOUT AND SCHEMATIC DIAGRAM**

Figure 5-1 shows a component layout of the Model 7164, while Figure 5-2 shows a schematic diagram.

# MODEL 7164, PARTS LIST

CIRCUIT DESIG.	DESCRIPTION	KEITHLEY PART NO.
C1	CAP,.01uF,20%,50V, CERAMIC	C-365-.01
C2	CAP,10uF,-20+100%,25V, ALUM ELEC	C-314-10
CR1-CR19, CR20-CR22	DIODE,SILICON,IN4148 (DO-35)	RF-28
J2	CONN,MALE,50 PIN	CS-307
K1-K20	REED RELAY (MODEL 7164-D)	RL-130
	REED RELAY (MODEL 7164-M)	RL-122
Q1,Q2	TRANS,PNP SILICON, 2N3906 (TO-92)	TG-84
R1,R3	RES,10K,5%,1/4W,COMPO- SITION OR FILM	R-76-6.8K
R2,R4	RES,2K,5%,1/4,COMPO- SITION OR FILM	R-76-2K

## MISCELLANEOUS, PARTS LIST

---

DESCRIPTION	KEITHLEY PART NO.
HANDLE	FA-119
MATING CONNECTOR	CS-640
MOUNTING BRACKETS	7164-303
CONNECTOR SHELL	CS-940

---

7164-100  
DN

LTR.	ECO NO.	REVISION	ENG.	DATE
A	12745	RELEASED	SZ	4/14/88
B	12947	REVISED	SZ	8/10/88
B1	13004	REVISED	SZ	9/27/88
C	12993	CHG'D MAT. FROM REV B TO C. RENUMBERED JUMPER	SZ	7/14/89

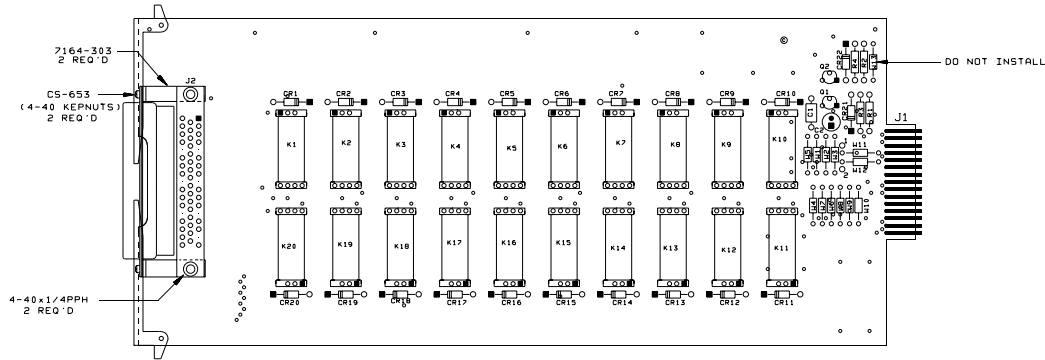

NOTE: FOR MORE COMPONENT INFORMATION SEE  
BILL OF MATERIAL 7164D-000-00 OR  
7164M-000-00.

MODEL	NEXT ASSEMBLY	QTY.
7164M		
7164D		
USED ON		

DO NOT SCALE THIS DRAWING		DIMENSIONAL TOLERANCES UNLESS OTHERWISE SPECIFIED		DATE 4/13/88	SCALE 1:1	TITLE
[KEITHLEY] KEITHLEY INSTRUMENTS INC CLEVELAND, OHIO 44139		XX=±.015	ANG.=±1°	DRN. MH	ENG. HPPA, DK	COMPONENT LAYOUT, 20 CHANNEL LOW COST
		XXX=±.005	FRAC.=±1/64	MATERIAL		ND.
		SURFACE MAX. 63		FINISH		C
						7164-100

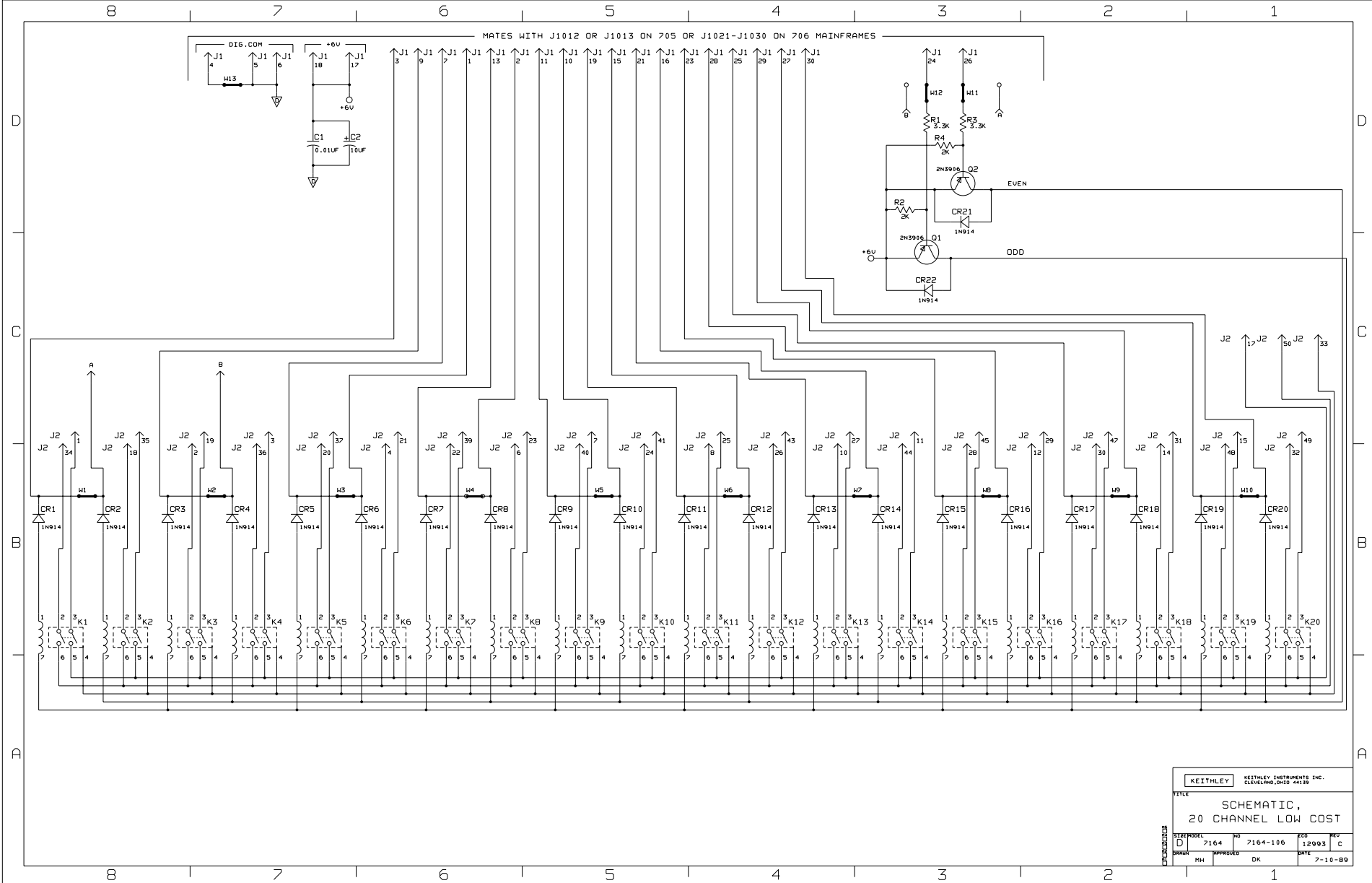

KEITHLEY KEITHLEY INSTRUMENTS INC.  
 CLEVELAND, OHIO 44139  
 SCHEMATIC,  
 20 CHANNEL LOW COST  
 SIZE MODEL 7164 7164-106 ECO REV 12993 C  
 DRAWN MMH APPROVED OK DATE 7-10-69



# Service Form

Model No. \_\_\_\_\_ Serial No. \_\_\_\_\_ Date \_\_\_\_\_

Name and Telephone No. \_\_\_\_\_

Company \_\_\_\_\_

List all control settings, describe problem and check boxes that apply to problem. \_\_\_\_\_

- |                                                  |                                                          |                                                                          |
|--------------------------------------------------|----------------------------------------------------------|--------------------------------------------------------------------------|
| <input type="checkbox"/> Intermittent            | <input type="checkbox"/> Analog output follows display   | <input type="checkbox"/> Particular range or function bad; specify _____ |
| <input type="checkbox"/> IEEE failure            | <input type="checkbox"/> Obvious problem on power-up     | <input type="checkbox"/> Batteries and fuses are OK                      |
| <input type="checkbox"/> Front panel operational | <input type="checkbox"/> All ranges or functions are bad | <input type="checkbox"/> Checked all cables                              |

Display or output (check one)

- |                                           |                                                              |
|-------------------------------------------|--------------------------------------------------------------|
| <input type="checkbox"/> Drifts           | <input type="checkbox"/> Unable to zero                      |
| <input type="checkbox"/> Unstable         | <input type="checkbox"/> Will not read applied input         |
| <input type="checkbox"/> Overload         |                                                              |
| <input type="checkbox"/> Calibration only | <input type="checkbox"/> Certificate of calibration required |
| <input type="checkbox"/> Data required    |                                                              |

(attach any additional sheets as necessary)

Show a block diagram of your measurement system including all instruments connected (whether power is turned on or not). Also, describe signal source.

Where is the measurement being performed? (factory, controlled laboratory, out-of-doors, etc.) \_\_\_\_\_

What power line voltage is used? \_\_\_\_\_ Ambient temperature? \_\_\_\_\_ °F

Relative humidity? \_\_\_\_\_ Other? \_\_\_\_\_

Any additional information. (If special modifications have been made by the user, please describe.) \_\_\_\_\_

Be sure to include your name and phone number on this service form.



Specifications are subject to change without notice.

All Keithley trademarks and trade names are the property of Keithley Instruments, Inc. All other trademarks and trade names are the property of their respective companies.



**Keithley Instruments, Inc.** 28775 Aurora Road • Cleveland, Ohio 44139 • 440-248-0400 • Fax: 440-248-6168  
1-888-KEITHLEY (534-8453) [www.keithley.com](http://www.keithley.com)