

# Making Temperature Measurements with the Keithley Model 2110 5½-Digit Dual-Display Digital Multimeter (DMM)

Many Keithley electrometers, switch/multimeter systems, data acquisition systems, and digital multimeters include temperature measurement capabilities, making them quite useful in a variety of applications in which temperature measurements are needed. This application note focuses on methods of measuring temperature with the Model 2110 DMM, specifically, thermocouple, resistance temperature detector (RTD), and Negative Temperature Coefficient Thermistor (NTCT) measurements.

## Thermocouple Measurements

Thermocouples join two dissimilar metals that produce a voltage proportional to the temperature difference between the conductor ends. This voltage is then measured and compared to a reference within the measurement device, the cold junction compensation (CJC) sensor.

The CJC sensor compensates for the thermocouple effect at the connection of the thermocouple to the measurement circuitry. The IC or thermistor used as the CJC is measured by the instrument, and the thermocouple effect within the instrument is cancelled out from the measurement.

The Model 2110 DMM measures this voltage through the dedicated thermocouple inputs on its front panel (labeled “TC INPUT”). The main advantages of thermocouples lie in their low cost and high durability. However, they are weaker than other temperature measurement sensors in accuracy. The Model 2110 has support for J-, R-, S-, T-, E-, N-, B-, C-, and K-type thermocouples. Each type has a different operating temperature range and differences in use cases.

### Thermocouple temperature measurement ranges.

Thermocouple Type	Temperature Range (°C)	Temperature Range (°F)
B	600 to 1820	1112 to 3308
C	0 to 2316	32 to 4200
E	-250 to 1000	-418 to 1832
J	-210 to 1200	-346 to 2192
K (default)	-200 to 1372	-328 to 2501
N	-200 to 1300	518 to 2372
R	0 to 1767	32 to 3212
S	0 to 1767	32 to 3212
T	-250 to 400	-418 to 752

## B-Type Thermocouples

B-type thermocouples are more stable and work at higher temperatures.

## C-Type Thermocouples

C-type thermocouples work well at extremely high temperatures, but not in the presence of oxygen.

## E-Type Thermocouples

E-type thermocouples work well at very low temperatures and thus are well-suited for cryogenic applications.

## J-Type Thermocouples

J-type thermocouples have higher sensitivity, potentially increasing accuracy and precision.

## K-Type Thermocouples

K-type thermocouples are the most commonly used due to their low price and wide range.

## N-Type Thermocouples

N-type thermocouples deal with many of the effects of EMF that plague other thermocouple types.

## R-Type Thermocouples

R-type thermocouples are well-suited for high temperatures and resist oxidation and reduction well.

## S-Type Thermocouples

S-type thermocouples are more accurate and are good for use in high-temperature environments.

## T-Type Thermocouples

T-type thermocouples have higher accuracies due to homogenous component wires (both copper) but have a narrower operational range.

The thermocouple measurement function can be activated on the front panel through the following steps:

Set up the thermocouple measurement.

1. Press SHIFT+TEMP.

Configure the measurement.

1. Press CONFIG.
2. Use ◀ or ▶ button to select TCOUPL's TYPE (K TYPE, J TYPE, R TYPE, S TYPE, T TYPE, E TYPE, N TYPE, B TYPE, or C TYPE), UNITS (°C, °F, or K), or RJUNCTION (REAL or SIMULATED) settings or to VIEW REAL (view the value read from the CJC).

The following SCPI commands mirror the operations described in the front panel operation:

1. SENS:FUNC:TCO
2. SENS:TCO:TYPE:<a>  
where <a> is E, J, K, N, R, S, or T
3. SENS:TCO:UNIT:<name>  
where <name> is Far, Cel, or K
4. SENS:TCO:RJUN:RSEL:<name>  
where <name> is REAL or SIM
5. SENS:TCO:RJUN:REAL?

## RTD (Resistance Temperature Detector) Measurements

RTD sensors use a pure material with known temperature/resistance behavior to determine the temperature at the probe. The Model 2110 DMM measures the resistance of the RTD element, compares it to known RTD resistance characteristics, and reports a voltage. See **Figure 1** for setup instructions for different RTD characteristics.

RTDs are relatively accurate and tend to give repeatable measurements. However, they tend to be fragile and are not accurate at higher temperatures (greater than 600°C).

The RTD measurement function can be activated on the Model 2110 front panel via the following steps:

Set up the RTD measurement.

1. Press TEMP.

Configure the measurement.

2. Press CONFIG.
3. Use ◀ or ▶ button to select TEMP's SENSOR (PT100, D100, F100, PT385, PT3916, USER, or SPRTD), UNITS (oC, oF, or K), or TRANSDUCER (4W RTD or 2W RTD).

Note: Select 4W RTD to measure a 3W RTD.

The following SCPI commands mirror the operations described in the Model 2110 front panel operation:

1. SENS:FUNC:TEMP
2. SENS:TEMP:RTD:<a>  
where <a> is PT100, D100, F100, P385, PT3916, USER, or SPRTD
3. SENS:TEMP:UNIT:<name>  
where <name> is Far, Cel, or K
4. SENS:TEMP:TRAN:<name>  
where <name> is FRTD or RTD

## NTCT (Negative Temperature Coefficient Thermistor) Measurements

Thermistors are resistors whose values change with temperature. NTCTs are a subset of these thermistors in which resistance decreases with increasing temperature. The following equation (the Steinhart-Hart equation) shows the relationship between temperature (T) and resistance (R) when a, b, and c are thermistor parameters:

$$\frac{1}{T} = a + b \ln(R) + c \ln^3(R)$$

The Model 2110 DMM measures the R value and uses user-defined a, b, and c values to calculate T. An NTCT is best used in lower temperatures where accuracy is more important.

The NTCT measurement function can be activated on the Model 2110 front panel through the following steps:

Set up the NTCT measurement.

1. Press TEMP.
2. Press CONFIG.
3. Use ◀ or ▶ button to select UNITS.
4. Use ◀ or ▶ button to select TRANSDUCER.
5. Use ◀ or ▶ button to select SENSOR.
  - a. Use ◀ or ▶ button to select NTCT.

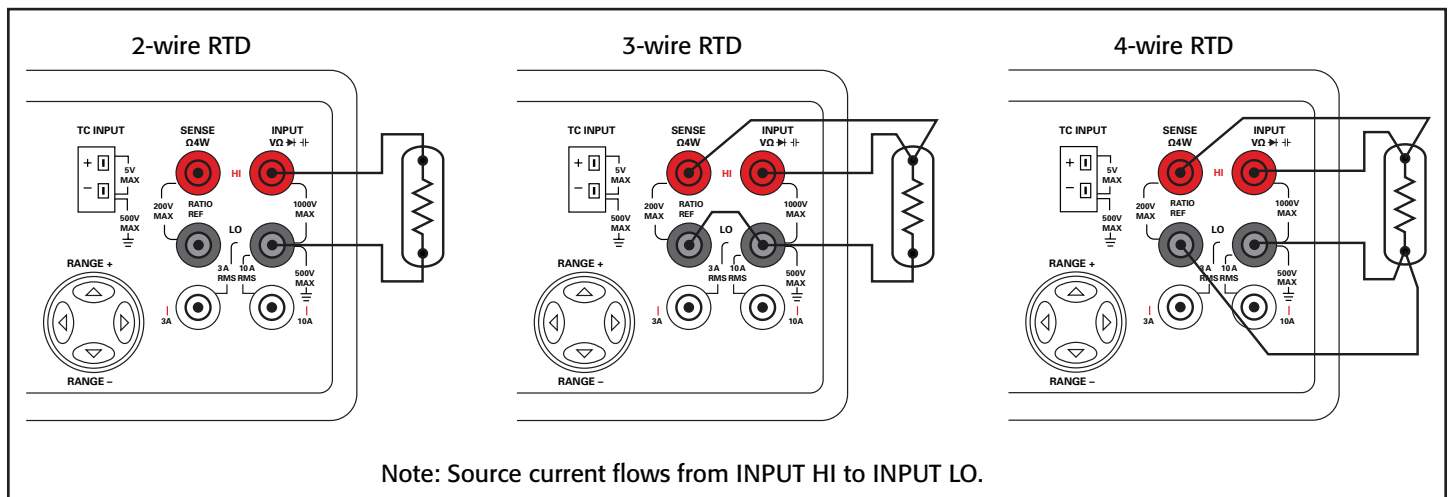

Figure 1. Connections for RTD measurements.

- b. Press ENTER.
- c. Change the value of A using arrow keys.
- d. Press ENTER twice.
- e. Change the value of B using arrow keys.
- f. Press ENTER twice.
- g. Change the value of C using arrow keys.
- h. Press ENTER.

Configure the measurement.

1. Press CONFIG.
2. Use ◀ or ▶ button to select UNITS (°C, °F, or K), or TRANSDUCER (4W RTD or 2W RTD).

The following SCPI commands mirror the operations described in the front panel operation:

1. SENS:FUNC:TEMP
2. SENS:TEMP:RTD:NTCT
3. SENS:TEMP:UNIT:<name>  
where <name> is Far, Cel, or K
4. SENS:TEMP:TRAN:<name>  
where <name> is FRTD or RTD

Note: A,B, and C parameters for NTCT measurements can only be set through the front panel.

**Temperature Measurements with Keithley Instruments**

<b>Thermocouple Measurements</b>	<b>RTD Measurements</b>	<b>Thermistor (NTCT) Measurements</b>
Model 6517B Electrometer	Model 3706A System Switch/Multimeter	Model 2110 DMM
Model 3706A System Switch/Multimeter	Models 2700, 2701, and 2750 Multimeter/Data Acquisition/Switch systems	
Models 2700, 2701, and 2750 Multimeter/Data Acquisition/Switch systems	Models 2110, 2100, 2000, 2001, 2002, 2010, 2015, and 2016 DMMs	
Models 2110, 2100, 2000, 2001, 2002, 2010, 2015, and 2016 DMMs		

Specifications are subject to change without notice. All Keithley trademarks and trade names are the property of Keithley Instruments, Inc.  
All other trademarks and trade names are the property of their respective companies.



KEITHLEY INSTRUMENTS, INC. ■ 28775 AURORA RD. ■ CLEVELAND, OH 44139-1891 ■ 440-248-0400 ■ Fax: 440-248-6168 ■ 1-888-KEITHLEY ■ www.keithley.com

**BELGIUM**

Sint-Pieters-Leeuw  
Ph: 02-3630040  
Fax: 02-3630064  
info@keithley.nl  
www.keithley.nl

**CHINA**

Beijing  
Ph: 86-10-8447-5556  
Fax: 86-10-8225-5018  
china@keithley.com  
www.keithley.com.cn

**FRANCE**

Les Ulis  
Ph: 01-69868360  
Fax: 01-69868361  
info@keithley.fr  
www.keithley.fr

**GERMANY**

Germering  
Ph: 089-84930740  
Fax: 089-84930734  
info@keithley.de  
www.keithley.de

**INDIA**

Bangalore  
Ph: 080-30792600  
Fax: 080-30792688  
support\_india@keithley.com  
www.keithley.in

**ITALY**

Peschiera Borromeo (Mi)  
Ph: 02-5538421  
Fax: 02-55384228  
info@keithley.it  
www.keithley.it

**JAPAN**

Tokyo  
Ph: 81-3-6714-3070  
Fax: 81-3-6714-3080  
info.jp@keithley.com  
www.keithley.jp

**KOREA**

Seoul  
Ph: 82-2-574-7778  
Fax: 82-2-574-7838  
keithley@keithley.co.kr  
www.keithley.co.kr

**MALAYSIA**

Penang  
Ph: 60-4-643-9679  
Fax: 60-4-643-3794  
sea@keithley.com  
www.keithley.com

**NETHERLANDS**

Son  
Ph: 040-2675502  
Fax: 040-2675509  
info@keithley.nl  
www.keithley.nl

**SINGAPORE**

Singapore  
Ph: 65-6747-9077  
Fax: 65-6747-2991  
sea@keithley.com  
www.keithley.com.sg

**TAIWAN**

Hsinchu  
Ph: 886-3-572-9077  
Fax: 886-3-572-9031  
info\_tw@keithley.com  
www.keithley.com.tw

**UNITED KINGDOM**

Bracknell  
Ph: 044-1344-392450  
Fax: 044-1344-392457  
info@keithley.co.uk  
www.keithley.co.uk