

KEITHLEY

# Data Acquisition and Control Handbook

A Guide to Hardware and Software for  
Computer-Based Measurement and Control

1<sup>st</sup>  
Edition

---

# Data Acquisition and Control Handbook

*A Guide to Hardware and Software for  
Computer-Based Measurement and Control*

---

**KEITHLEY**

## Preface

The *Data Acquisition and Control Handbook* is a comprehensive overview of issues that influence the selection and use of equipment for computerized data acquisition and control. The handbook is primarily a guide to building test and measurement systems that use a personal computer as a controller and a variety of plug-in boards and external instruments to gather data and control external processes. These processes cover multiple industries and markets, including the fields of factory automation, semiconductors, optoelectronics, telecommunications, automotive, medical, computers, peripherals, aerospace, research, and education. The goals of this handbook include:

- Identifying basic electrical theory that applies to measurement and control, regardless of the application or selected instrumentation.
- Identifying the fundamental building blocks, sensors, and processes of data acquisition, in order to help the reader form a sound approach to system design.
- Discussing common data acquisition applications that can serve as models for developing similar systems.

The history behind some current practices is also noted.

Journals, texts, and the World Wide Web are good sources for more information on specific applications and topics. Search engines can be invaluable for identifying vendors specializing in many types of sensors, along with recommendations on instrumentation suitable for specific applications.

For background on making more accurate measurements of low-level signals, request a copy of Keithley's *Low Level Measurements*, which provides a thorough grounding in the field of sensitive electronic measurement.

# TABLE OF CONTENTS

## **Section 1: Data Acquisition and Control Overview**

<b>1.1 Definition</b>	<b>1-2</b>
<b>1.2 Data Acquisition and Control Hardware</b>	<b>1-2</b>
1.2.1 Plug-in Data Acquisition Boards	1-3
1.2.2 External Data Acquisition Systems	1-3
1.2.2.1 Real-Time Data Acquisition and Control	1-4
1.2.2.2 Discrete (Bench/Rack) Instruments	1-5
1.2.2.3 Hybrid Data Acquisition Systems	1-5

## **Section 2: Communication Buses and Protocols**

<b>2.1 Computer Hardware Overview</b>	<b>2-2</b>
<b>2.2 Processor</b>	<b>2-2</b>
<b>2.3 Bus Architecture</b>	<b>2-3</b>
2.3.1 ISA	2-3
2.3.2 PCI	2-4
2.3.3 PCMCIA	2-5
<b>2.4 Connectivity</b>	<b>2-5</b>
2.4.1 Serial Ports (RS-232, RS-422, RS-485)	2-5
2.4.2 Parallel Port	2-8
2.4.3 IEEE-488 (GPIB)	2-8
2.4.4 Universal Serial Bus (USB)	2-9
2.4.5 IEEE-1394 FireWire	2-10
2.4.6 Distributed Measurements and Ethernet	2-11
2.4.7 Converters, Extenders, Repeaters	2-12

## **Section 3: Software Overview**

<b>3.1 System Software</b>	<b>3-2</b>
<b>3.2 Open vs. Closed Programming Environments</b>	<b>3-2</b>
3.2.1 History of Open vs. Closed Programming Environments	3-2
3.2.2 Open vs. Closed Programming Environments Today	3-3
3.2.2.1 Learning Curve	3-4
3.2.2.2 Text-Based vs. Graphical Syntax	3-4

3.2.2.3	Programming Efficiency .....	3-5
3.2.2.4	Windows Messaging and Event Management .....	3-6
3.2.2.5	Debugging .....	3-7
3.2.2.6	Application Deployment .....	3-7
<b>3.3</b>	<b>Software Development under Windows .....</b>	<b>3-7</b>
3.3.1	Software Structure Overview .....	3-7
3.3.2	Device Drivers .....	3-7
3.3.2.1	Driver Development .....	3-8
3.3.2.2	The Evolution from DOS to Windows .....	3-9
3.3.3	The Application Programming Interface .....	3-10
3.3.3.1	The Role of an API .....	3-10
3.3.3.2	Hardware Independence .....	3-10
3.3.3.3	ActiveX Controls .....	3-11
3.3.3.4	The Benefit of ActiveX .....	3-11
<b>3.4</b>	<b>FIFO and Buffer Overrun Issues .....</b>	<b>3-12</b>
3.4.1	The Role of DMA .....	3-13
3.4.2	Polled vs. Event-Driven Control .....	3-13
3.4.3	Tight Control .....	3-14
3.4.4	Managing Speed and Accuracy Tradeoffs .....	3-15

## **Section 4: Basic Component Theory**

<b>4.1</b>	<b>Introduction .....</b>	<b>4-2</b>
<b>4.2</b>	<b>Passive Components .....</b>	<b>4-2</b>
4.2.1	Resistors .....	4-2
4.2.1.1	Resistor Applications .....	4-3
4.2.2	Capacitors .....	4-6
4.2.3	Inductors .....	4-10
<b>4.3</b>	<b>Op Amp Theory .....</b>	<b>4-11</b>
4.3.1	Types .....	4-12
4.3.2	Power Supply .....	4-12
4.3.3	Input and Output Impedance .....	4-12
4.3.4	Gain .....	4-13
4.3.5	Feedback .....	4-13
4.3.6	Inverting vs. Non-Inverting Operation .....	4-14
4.3.7	Normal Mode and Common Mode Voltages .....	4-15

4.3.8	Single-Ended vs. Differential, Bipolar vs. Unipolar	4-17
4.3.9	Single-Ended vs. Differential Inputs for Signal Measurement	4-19
<b>4.4</b>	<b>Filters</b>	<b>4-19</b>
<b>4.5</b>	<b>Digital I/O</b>	<b>4-21</b>
4.5.1	Digital Logic Types and Logic Levels	4-22
4.5.2	TTL Logic	4-23
4.5.3	CMOS Logic	4-24

## **Section 5: Basic Analog and Digital I/O**

<b>5.1</b>	<b>A/D Conversion</b>	<b>5-2</b>
5.1.1	A/D Resolution and Speed	5-2
5.1.2	Resolution	5-3
5.1.3	Input Accuracy	5-5
5.1.4	Maximum A/D Speed	5-5
5.1.5	A/D Techniques	5-6
5.1.5.1	Successive Approximation A/D	5-7
5.1.5.2	Integrating A/D	5-7
5.1.5.3	Flash Conversion	5-7
5.1.5.4	Sigma-Delta Conversion	5-8
5.1.6	Aliasing and Anti-Aliasing Filters	5-8
<b>5.2</b>	<b>D/A Conversion</b>	<b>5-9</b>
5.2.1	Four-Wire Remote Sensing	5-10
<b>5.3</b>	<b>Interfacing Digital I/O to Applications</b>	<b>5-10</b>
5.3.1	Interfacing with Mechanical Switches	5-11
5.3.2	Contact Debouncing	5-12
5.3.3	Dry Switching	5-13
5.3.4	Slow Moving Signals	5-13
5.3.5	Dealing with TTL-Incompatible Signal Levels	5-14
5.3.6	Digital High Current or High Voltage	5-14
<b>5.4</b>	<b>Isolation</b>	<b>5-15</b>
5.4.1	Digital Isolation	5-16
5.4.2	Analog Isolation	5-17
<b>5.5</b>	<b>Ground Loops</b>	<b>5-18</b>

## **Section 6: Temperature Measurement**

<b>6.1 Temperature</b>	<b>6-2</b>
<b>6.2 Thermocouples</b>	<b>6-2</b>
6.2.1 Features and Operating Principle of the Thermocouple	6-2
6.2.1.1 Advantages and Disadvantages of Thermocouples	6-2
6.2.1.2 Operating Principle of the Thermocouple	6-3
6.2.1.3 Simplifying the Measurement System	6-4
6.2.1.4 Linearization	6-7
6.2.1.5 Thermocouple Alloys, Extensions, Terminal Pins, and Other Interconnects	6-8
6.2.2 Physical Construction of Commercial Thermocouples	6-8
6.2.3 Thermocouple Types and Applications	6-10
6.2.3.1 Base Metal Thermocouples	6-10
6.2.3.2 Noble Metal Thermocouples	6-10
6.2.3.3 Other Types of Thermocouples	6-12
<b>6.3 Resistive Temperature Detectors</b>	<b>6-12</b>
6.3.1 Construction	6-13
6.3.2 Principle of Operation	6-13
6.3.3 Application of RTDs	6-14
6.3.4 Three-Wire Bridge Configuration	6-16
6.3.5 Four-Wire RTD Configuration	6-17
6.3.6 Converting RTD Resistance to Temperature	6-17
6.3.7 Excitation Current and Joule Heating	6-18
<b>6.4 Thermistors</b>	<b>6-19</b>
6.4.1 Thermistor Circuit Configuration	6-19
6.4.2 Converting Thermistor Resistance to Temperature	6-20
<b>6.5 Semiconductor Linear Temperature Sensors</b>	<b>6-21</b>
<b>6.6 Thermal Shunting</b>	<b>6-21</b>

## **Section 7: Strain Measurement**

<b>7.1 Strain</b>	<b>7-2</b>
<b>7.2 Poisson's Strain</b>	<b>7-2</b>
<b>7.3 Strain Gauges</b>	<b>7-2</b>

<b>7.4 Gauge Factor</b>	<b>7-6</b>
<b>7.5 Sources of Error</b>	<b>7-6</b>
<b>7.6 Operation</b>	<b>7-7</b>
7.6.1 Full Bridge Configuration	7-7
7.6.2 Half Bridge Configuration	7-8
7.6.3 Quarter Bridge Configuration	7-9
<b>7.7 Strain Gauge Signal Conditioning</b>	<b>7-10</b>
<b>7.8 Shunt Calibration</b>	<b>7-10</b>
<b>7.9 Load Cells, Pressure Sensors, and Flow Sensors</b>	<b>7-11</b>
<b>7.10 Acceleration, Shock, and Vibration</b>	<b>7-12</b>
7.10.1 Acceleration	7-12
7.10.2 Shock	7-13
7.10.3 Vibration	7-13
7.10.4 Resonance and “Q”	7-13
7.10.5 Accelerometer Types	7-14
7.10.5.1 Strain Gauge Accelerometer	7-15
7.10.5.2 Piezoelectric Accelerometer	7-16
7.10.5.3 Spring-Resistive Accelerometer	7-16
7.10.6 Instrumentation Requirements	7-16

## **Section 8: Related Topics of Interest**

<b>8.1 Current Measurements</b>	<b>8-2</b>
8.1.1 Voltage Burden	8-2
8.1.2 DMM vs. A/D Board for Current Measurements	8-3
<b>8.2 Connection Theory</b>	<b>8-4</b>
8.2.1 Cable Type	8-4
8.2.2 Conductors	8-5
8.2.3 Shielding	8-5
8.2.4 Cable Capacitance	8-7

## **Section 9: Application Examples**

<b>9.1 Introduction</b>	<b>9-2</b>
<b>9.2 OEM/Factory Automation and Data Acquisition</b>	<b>9-2</b>
9.2.1 Design Considerations	9-3



9.2.2	Measurement Integrity .....	9-4
<b>9.3</b>	<b>Semiconductor CVD Application .....</b>	<b>9-5</b>
<b>9.4</b>	<b>Process Monitoring in a Nuclear Power Plant .....</b>	<b>9-6</b>
<b>9.5</b>	<b>Tensile Test Stand Application .....</b>	<b>9-8</b>
<b>9.6</b>	<b>Burn-In and Stress Testing of Electronic Devices .....</b>	<b>9-9</b>
<b>9.7</b>	<b>Performance Characterization of Shock Absorbers .....</b>	<b>9-11</b>
<b>9.8</b>	<b>Instrument-Grade, Low Cost Analog Output Control .....</b>	<b>9-12</b>
9.8.1	Four-Wire Remote Sense Test Description .....	9-12
9.8.2	Four-Wire Remote Sense Test Procedure .....	9-12
9.8.3	Constant Current Source Test Description .....	9-14
9.8.4	Quadrant I, Resistive Load Test Procedure .....	9-15
9.8.5	Quadrant I and III, Battery Charge/Discharge Test Procedure ..	9-16
9.8.6	Source/Sink Test Description .....	9-17
9.8.7	Quadrant I and II, Battery Charge/Discharge Test Procedure ..	9-17

**Appendix A: Selection Guide for Plug-in Boards vs.  
External Data Acquisition Instruments**

**Appendix B: Glossary**

**Appendix C: Diameter and Resistance of Various Wire Gauges**

**Appendix D: Safety Considerations**

**Index**

---

SECTION 1

Data Acquisition and  
Control Overview

---

## 1.1 Definition

Although concepts like *data acquisition* and *test and measurement* can be surprisingly difficult to define completely, most computer users, engineers, and scientists agree there are several common elements:

- A personal computer (PC) is used to program test equipment and manipulate or store data. The term “PC” is used in a general sense to include any computer running any operating system and software that supports the desired result. The PC may also be used for supporting functions, such as real-time graphing or report generation. The PC may not necessarily be in constant control of the data acquisition equipment or even remain connected to the data acquisition equipment at all times.
- Test equipment can consist of data acquisition plug-in boards for PCs, external board chassis, or discrete instruments. External chassis and discrete instruments typically can be connected to a PC using either standard communication ports or a proprietary interface board in the PC.
- The test equipment can perform one or more measurement and control processes using various combinations of analog input, analog output, digital I/O, or other specialized functions.

The difficulty involved in differentiating between terms such as *data acquisition*, *test and measurement*, and *measurement and control* stems from the blurred boundaries that separate the different types of instrumentation in terms of operation, features, and performance. For example, some stand-alone instruments now contain card slots and microprocessors, use operating system software, and operate more like computers than like traditional instruments. Some external instruments now make it possible to construct test systems with high channel counts that gather data and log it to a controlling computer. Plug-in boards can transform computers into multi-range digital multimeters, oscilloscopes, or other instruments, complete with user-friendly, on-screen virtual front panels.

For the sake of simplicity, this handbook uses the term “data acquisition and control” broadly to refer to a variety of hardware and software solutions capable of making measurements and controlling external processes. The term “computer” is also defined rather broadly; however, for most applications, a “computer” means an IBM-compatible PC running Microsoft® Windows® 95 or later, unless otherwise noted.

## 1.2 Data Acquisition and Control Hardware

Data acquisition and control hardware is available in a number of forms, which offer varying levels of functionality, channel count, speed, resolution, accuracy, and cost. This section summarizes the fea-

tures and benefits generally associated with the various categories, based on a broad cross-section of products. Refer to **Appendix A** for a comparison of plug-in boards and external instruments.

### 1.2.1 Plug-in Data Acquisition Boards

Like display adapters, modems, and other types of expansion boards, plug-in data acquisition boards are designed for mounting in board slots on a computer motherboard. Today, most data acquisition boards are designed for the current PCI (Peripheral Component Interconnect) or earlier ISA (Industry Standard Architecture) buses. Data acquisition plug-in boards and interfaces have been developed for other buses (EISA, IBM Micro Channel®, and various Apple buses), but these are no longer considered mainstream products.

As a category, plug-in boards offer a variety of test functions, high channel counts, high speed, and adequate sensitivity to measure moderately low signal levels, at relatively low cost.

*Table 1-1. Features of plug-in data acquisition boards*

Least expensive method of computerized measurement and control.
High speed available (100kHz to 1GHz and higher).
Available in multi-function versions that combine A/D, D/A, digital I/O, counting, timing, and specialized functions.
Good for tasks involving low-to-moderate channel counts.
Performance adequate to excellent for most tasks, but electrical noise inside the PC can limit ability to perform sensitive measurements.
Input voltage range is limited to approximately $\pm 10V$ .
Use of PC expansion slots and internal resources can limit expansion potential and consume PC resources.
Making or changing connections to board's I/O terminals can be inconvenient.

### 1.2.2 External Data Acquisition Systems

The original implementation of an external data acquisition system was a self-powered system that communicated with a computer through a standard or proprietary interface. As a boxed alternative to plug-in boards, this type of system usually offered more I/O channels, a quieter electrical environment, and greater versatility and speed in adapting to different applications.

Today, external data acquisition systems often take the form of a stand-alone test and measurement solution oriented toward industrial applications. The applications for which they are used typically demand more than a system based on a PC with plug-in boards can provide or this type of architecture is simply inappropriate for the application. Modern external data acquisition systems offer:

- High sensitivity to low-level voltage signals, i.e., approximately 1mV or lower.
- Applications involving many types of sensors, high channel counts, or the need for stand-alone operation.
- Applications requiring tight, real-time process control.

Like the plug-in board based system, these external systems require the use of a computer for operation and data storage. However, the computer can be built up on boards, just as the instruments are, and incorporated into the board rack. There are several architectures for external industrial data acquisition systems, including VME, VXI, MXI, Compact PCI, and PXI. These systems use mechanically robust, standardized board racks and plug-in instrument modules that offer a full range of test and measurement functions. Some external system designs include microprocessor modules that support all the standard PC user interface elements, including keyboard, monitor, mouse, and standard communication ports. Frequently, these systems can also run Microsoft Windows and other PC applications. In this case, a conventional PC may only be needed to develop programs or off-load data for manipulation or analysis.

*Table 1-2. Features of external data acquisition chassis*

Multiple board slots permit mixing-and-matching boards to support specialized acquisition and control tasks and higher channel counts.
Chassis offers an electrically quieter environment than a PC, allowing for more sensitive measurements.
Use of standard interfaces (IEEE-488, RS-232, USB, FireWire, Ethernet) can facilitate daisy chaining, networking, long distance acquisition, and use with non-PC computers.
Dedicated processor and memory can support critical “real-time” control applications or stand-alone acquisition independent of a PC.
Standardized modular architectures are mechanically robust, easy to configure, and provide for a variety of measurement and control functions.
Required chassis, modules, and accessories are cost-effective for high channel counts.
Some architectures have minimal vendor support, limiting the sources of equipment and accessories available.

### **1.2.2.1 Real-Time Data Acquisition and Control**

Critical real-time control is an important issue in data acquisition and control systems. Applications that demand real-time control are typically better suited to external systems than to systems based on PC plug-in boards. Although Microsoft Windows has become the standard operating system for PC applications, it is a non-deterministic operating system that can't provide predictable response times in critical

measurement and control applications. Therefore, the solution is to link the PC to a system that can operate autonomously and provide rapid, predictable responses to external stimuli.

### 1.2.2.2 Discrete (Bench/Rack) Instruments

Originally, discrete electronic test instruments consisted mostly of single-channel meters, sources, and related instrumentation intended for general-purpose test applications. Over the years, the addition of communication interfaces and advances in instrument design, manufacturing, and measurement technology have extended the range and functionality of these instruments. New products such as scanners, multiplexers, SourceMeter<sup>®</sup> instruments, counter/timers, nanovoltmeters, micro-ohmmeters, and other specialized instrumentation have made it possible to create computer-controlled test and measurement systems that offer exceptional sensitivity and resolution. Some systems of this type can service only one channel or just a few channels, so their cost per channel is high. However, the addition of switch matrices and multiplexers can lower the cost per channel by allowing one set of instruments to service many channels while preserving high signal integrity. These instruments can also be combined with computers that contain plug-in data acquisition boards.

**Table 1-3. Features of discrete instruments for data acquisition**

---

Support measurement ranges and sensitivities generally beyond the limits of standard plug-in boards and external data acquisition systems.

---

Use standard interfaces (e.g., IEEE-488, RS-232, FireWire, USB) that support long-distance acquisition, compatibility with non-IBM-compatible computers, or use with computers without available expansion slots.

---

Most suitable for measurement of voltage, current, resistance, capacitance, inductance, temperature, etc. May not be effective solutions for some types of specialized sensors or signal conditioning requirements.

---

Generally slower than plug-in boards or external data acquisition systems.

---

More expensive than standard data acquisition systems on a per-channel basis.

---

### 1.2.2.3 Hybrid Data Acquisition Systems

Hybrid systems are a relatively recent development in external data acquisition systems. A typical hybrid system combines a DMM-type user interface with several standard data acquisition functions and expansion capabilities in a compact, instrument-like package. Typical functions include AC and DC voltage and current measurements, temperature and frequency measurements, event counting, timing, triggering, and process control. Keithley's Integra™ Series, which includes the Model 2700 and Model 2750 and their associated plug-in modules, provides multiple board slots for expanding the system's measurement capabilities and channel capacity (**Figure 1-1**).



*Figure 1-1. Keithley Model 2700 hybrid data acquisition system*

**Table 1-4. Features of a hybrid data acquisition system**

---

Delivers accuracy, measurement range, and sensitivity typical of bench DMMs, and superior to standard data acquisition equipment.

---

DMM front end with digital display and front panel controls provides resolution equivalent to a DMM (18- to 22-bit A/D or better).

---

Built-in data and program storage memory for stand-alone data logging and process control.

---

Uses standard interfaces (IEEE-488) that support long-distance acquisition and provide compatibility with non-PC computers.

---

Cost-effective on a per-channel basis.

---

Limited expansion capacity (less critical because base test capability is already complete).

---

Generally slower than plug-in boards or external data acquisition systems.

---

---

SECTION 2

Communication Buses  
and Protocols

---



## 2.1 Computer Hardware Overview

The overall performance, suitability, and long-term usefulness of a PC-based data acquisition system often depends as much on the PC used as on the measurement hardware. As a general rule, a faster processor, more memory, and more disk storage will improve system performance. It is also important to follow the recommendations on hardware and software given by manufacturers concerning compatible computers and peripherals.

## 2.2 Processor

PC manufacturers introduce faster, more powerful PCs continually by making improvements in architecture, processor speed, disk storage, memory, peripherals, etc. Often, these improvements are incremental, so they may not provide sufficient incentive to the user to replace an existing PC. Therefore, the installed base of PCs used in test and measurement will contain several product generations, each with varying degrees of suitability for a desired application.

A survey of computing hardware recommended for use with various data acquisition products will show that few require the use of a cutting-edge PC to function. While the minimum system requirements for installing and running most new software applications continues to escalate, these requirements are typically a few generations behind the current state of PC technology. For example, when a typical high-end PC included a Pentium® III processor and 64–128MB of RAM, the minimum workable system for many data acquisition hardware and software products was still an 80486 processor with just 8–32MB of RAM. A *recommended* system would fall somewhere between the extremes; for example, a Pentium-class PC with a 233MHz processor, 64MB RAM, 5–10GB of fixed disk storage, and a VGA display adapter capable of 256 colors at 800×600 resolution.

Be aware that while a minimum PC configuration may offer sufficient resources to manage the test and measurement task, it probably can't handle much more. Spreading resources too thin by running multiple programs during data acquisition can result in sluggish program response, lock-ups, or other problems.

Increasing the amount of on-board RAM can boost system performance dramatically, especially with Windows operating systems. For large or concurrent applications, adding RAM can reduce the need for the system to swap information to and from disk drives, which is far more time-consuming than retrieving the same information from RAM. Compared to upgrading a processor, motherboard, or an entire system, installing more RAM is a relatively easy and inexpensive way to extend the useful life of an older machine.

In 2001, most newer PCs contain PCI expansion slots, but few (if any) ISA slots. Although the PCI architecture offers some advantages in terms of speed of interrupt handling, some users may find it easier to continue using ISA if they have a sizeable investment in ISA-based test and measurement systems platforms, software, and maintenance resources. Even as PCI-based machines assume architectural leadership, PC manufacturers have begun to discuss producing slotless PCs that will require the use of external test and measurement hardware.

## 2.3 Bus Architecture

Over the PC's history, a number of internal PC buses have been developed. The original ISA (Industry Standard Architecture) bus and the current PCI (Peripheral Component Interconnect) bus are the two most common architectures employed for data acquisition products.

A few other architectures, notably IBM's Micro Channel Architecture (MCA), the Enhanced Industry Standard Architecture (EISA), and the Video Electronics Standards Association (VESA) local bus, were introduced prior to the PCI. All these buses were designed to replace or augment the ISA bus with advanced features that are now common to PCI. These features included higher speed, 32-bit operation, Plug-and-Play operation, and bus mastering. The simple but well-established ISA bus has actually outlasted all of them. While a few Micro Channel and Apple data acquisition products were developed, neither architecture took lasting root in the data acquisition market. Today, neither is regarded as a mainstream data acquisition platform.

### 2.3.1 ISA

The ISA bus was a core element of the original IBM PC (ca. 1981), although the term "ISA" was not adopted until the bus was well established and other buses were introduced by IBM and other computer manufacturers. Initially, the ISA bus was an 8-bit, 4.77MHz bus designed to satisfy the speed and data path requirements of the PC's 8088 processor. In 1984, the ISA bus was upgraded to 16 bits and 8MHz for the 80286 processor used in the IBM PC/AT, and the card-edge connector was physically extended to provide a 16-bit data path. Both the 8-bit and 16-bit variations are included under the general term "ISA." ISA plug-in data acquisition boards and communication interfaces still exist today. Some have only the primary 8-bit card edge connector and will fit an 8- or 16-bit ISA slot. Sixteen-bit boards include the secondary card edge extension and will only fit a 16-bit ISA slot.

Direct Memory Access (DMA) and Plug-and-Play (PnP) are two noteworthy features of the ISA bus. DMA improves data transfer between peripherals and memory by enabling an expansion board to write to system memory directly, without intervention of the microprocessor. Strictly speaking, Plug-and-Play was introduced on later ISA

boards to coincide with the introduction of Windows 95. PnP enabled Windows 95 to identify the boards present in the PC's expansion slots. However, the concept of automatic board identification was a feature of MCA and EISA architectures years before Windows 95. Unfortunately, the prevailing DOS operating system did not support PnP, so few PCs could take advantage of this feature. Plug-and-Play operation requires a combination of PnP-compatible peripherals, system hardware, system BIOS, and operating system software.

Plug-and-Play capability allows a computer to recognize a new internal or external peripheral plugged into the system automatically, and to configure system resources (interrupts, memory addresses, etc.) to operate these devices. Without PnP, installing an ISA board typically involved setting physical jumpers or switches, or configuring the board through software to establish IRQ, I/O addresses, or DMA channels for the peripheral. In a heavily populated system, users could find it difficult to install all the desired peripherals without running out of resources or causing conflicts.

The ISA bus is a well-entrenched standard that will persist despite dwindling support from Intel, Microsoft, and computer manufacturers. Even in the 8-bit version, ISA's speed is more than adequate for many applications. A wide variety of ISA data acquisition boards remain available.

### 2.3.2 PCI

Intel introduced the 32-bit PCI (Peripheral Component Interconnect) bus in 1993. It appeared first in Pentium and later-generation '486 machines. PCI is the current PC bus standard and was the only internal PC bus approved by Intel and Microsoft as of January 2001.

The PCI bus offers a number of performance advantages over the ISA bus. The PCI bus runs at 33MHz compared to 8MHz for the ISA bus. PCI's improved PnP capability allows jumperless installation of PCI boards and automatic allocation of interrupts, I/O addresses, and DMA channels. Interrupts can be shared by different PCI devices. PCI also features "bus mastering," which, like DMA, allows PCI devices to take control of the bus and perform data transfers directly to memory, without intervention of the processor. PCI's improved design allows simultaneous bus mastering of multiple devices.

Since the introduction of the PCI bus, the total number of slots on motherboards has dwindled, and there are few (if any) ISA slots. However, a PCI-based machine with three or four PCI slots still maintains a high level of expansion capability. Hard disk controllers, serial and printer ports, sound, video, and other system resources that usually required separate interface boards in an ISA platform are now populated on PCI motherboards directly, leaving the few existing slots free for other peripherals. PCI data acquisition boards are available for

most applications implemented with ISA boards and provide for easier installation and better performance than ISA.

### 2.3.3 PCMCIA

Most laptop computers now include at least one Personal Computer Memory Card International Association (PCMCIA) slot, which enables the computer to accept data acquisition boards, interfaces, and other PCMCIA peripherals. In terms of architecture and performance, the PCMCIA bus most closely resembles the ISA bus with added Plug-and-Play and hot-swapping features. PCMCIA data acquisition boards are readily available, although the selection is limited in comparison with ISA and PCI versions. The PCMCIA bus also has less to offer in terms of channel counts, high resolution A/D, and A/D speeds greater than 100 kilosamples/second.

PCMCIA boards are roughly the size of a credit card, which requires cabling to an external connector pod or terminal block. This tiny form factor precludes some useful features typical of full-size boards, such as power supply regulation, advanced signal conditioning, and maximum tolerance of electrostatic discharges.

## 2.4 Connectivity

The topic of connectivity includes a variety of external buses and ports that are available on PCs, either as standard equipment or as plug-in interface options. These include parallel printer ports, the traditional RS-232 serial port, RS-422 and RS-485 serial ports, IEEE-488, and newer high speed buses such as the Universal Serial Bus (USB), IEEE-1394 FireWire® bus, and Ethernet. These buses are summarized in **Table 2-1**.

### 2.4.1 Serial Ports (RS-232, RS-422, RS-485)

The Electronic Industries Association's (EIA) RS-232 serial standard is one of the most common communication protocols. Introduced in 1962, RS-232 became an early common feature on mainframe and mini computers, data terminals, printers, modems, and other data equipment long before PCs were developed.

RS-232 was originally specified for data communications between a single driver device and a single receiver over distances up to 15 meters (50 feet), at speeds up to 19,200 bits per second. These distance and speed limits have proven to be conservative; RS-232 is now routinely used at speeds of 115–230 kbits/second. RS-232 has also been operated at distances greater than 25 meters. The ability to achieve these operating parameters depends on the environment and quality of cabling used. Generally speaking, a single system can't provide both maximum speed and maximum distance.

**Table 2-1. External PC buses**

<b>Generic Name</b>	<b>Industry Designation</b>	<b>Typical Max. Distance</b>	<b>Typical Max. Speed</b>	<b>Features/Advantages</b>
Serial	RS-232	15m (50ft)	115kbits/s	Standard serial interface. One device per port.
Serial	RS-422	1220m (4000ft)	115kbits/s	One transmitter may drive up to 10 receivers. Normally requires a plug-in RS-422 adapter.
Serial	RS-485	1220m (4000ft)	115kbits/s	Supports up to 32 transmit or receive devices on one bus. Normally requires a plug-in RS-485 adapter.
Parallel (Printer Port)	SPP, EPP, ECP	~15m (50ft)	100+ kB/s	Popular for printers, scanners, disk drives, other peripherals. Not a main-stream DAQ interface.
General Purpose Interface Bus (GPIB)	IEEE-488	~2m (6ft) Can be extended	1MB/s	A standard fixture on many scientific instruments and peripherals. Supports up to 15 devices on one bus. Normally requires a plug-in GPIB adapter.
Universal Serial Bus	USB	5m (16.5ft) per cable drop; 15m (50ft) total	12Mbits/s (480Mbits/s planned)	Supports "hot plugging," PnP, and connection of up to 127 devices using USB "hubs." USB is standard on many new computers. Driver support in W95 OSR 2.1, Win 98, Win 2000.
FireWire	IEEE-1394	4.5m (15ft)	100-400Mbits/s (1+ Gbits/s planned)	Supports "hot plugging," PnP, and daisy chaining of up to 63 devices. FireWire is not yet widely implemented. Driver support in Win 98, Win 2000.
Ethernet	10BaseT, 100BaseT	~925m (3000ft); farther on LANs or over Internet	10Mbits/s, 100Mbits/s*	Standard high speed office/ industrial network. Interface required for computer.

\*Raw bit rates. Actual throughput is application dependent.

The traditional RS-232 connector was a 25-pin D-shell design. However, many serial products now include 9-pin serial ports with (or in place of) the 25-pin version. Both port types contain the same nine signal lines, although pin numbers for specific signals are different. A full RS-232 link includes Tx (transmit), Rx (receive), signal ground, and several additional handshaking lines. Handshaking is important with some peripherals (such as modems) to control transmission and prevent data overrun. It is possible to establish serial communication for some applications using only Tx, Rx, and signal ground, in which case, handshake pins on each piece of serial equipment must be terminated with various loop-back and pull-up connections. Check the documentation for any RS-232 device to be used for pin-out and connection information.

A second popular serial standard, RS-422, is similar to RS-232, except that it uses differential data transmission. This method employs two active lines to transmit a signal, rather than RS-232's signal line and ground. Differential data transmission provides superior noise rejection, which supports higher data rates and greater operating distances. Data transmission speeds up to 115 kbits/second and distances up to 4000 feet are possible. As with RS-232, maximum speed and maximum distance are mutually exclusive. Connector pin designations for RS-422 differ from those for RS-232, so ports and equipment using these standards are incompatible. The RS-422's ability to handle multi-drop applications, where one driver device can transmit to up to ten receivers, is a significant advantage over the RS-232.

RS-485 is another popular serial standard, which combines elements of RS-422 with the ability to handle multiple receivers and multiple transmitters on one bus. Like RS-422, RS-485 uses differential data transmission and can operate at speeds of up to 115 kbits/second over distances up to 4000 feet. In addition, RS-485 can support up to 32 driver devices and 32 receivers, making it possible to construct a multi-point network of transmitters and receivers using a single RS-485 cable run.

With the possible exception of Ethernet, RS-422 and RS-485 provide the best combination of distance and ease of use for data acquisition applications. As with RS-232, achieving long-distance, error-free communication depends on cable quality and environmental conditions. At distances less than 4000 feet, allowable transmission speeds increase, with speeds up to 10 megabits/second possible at 50 feet. The use of high quality, shielded twisted pair cabling is critical to achieve optimum performance.

Plug-in RS-422 and RS-485 interfaces for ISA and PCI buses are readily available. Many bench-top instruments and some external data acquisition products include an RS-232 or IEEE-488 port, both of which can be converted to RS-422 or RS-485 by using the appropriate

adapter. RS-422 and RS-485 ports are more common on industrial systems, where support for long-distance data acquisition is a prime concern.

## 2.4.2 Parallel Port

A parallel printer port can be found on nearly every PC. The original purpose of this port was to drive a Centronics-compatible printer at a distance up to 50 feet. Over the years, other non-printer parallel peripherals have been introduced, including scanners, disk drives, and tape drives.

The parallel interface uses eight separate transmission lines, allowing data to be transmitted a byte at a time, and resulting in higher speeds than RS-232. More recently, the IEEE-1284 standard was drafted to describe five different uni-directional and bi-directional hardware configurations and operating enhancements for the parallel port. The first three modes are uni-directional and support data transfer rates up to 100 kbytes per second. The last two, EPP (Enhanced Parallel Port) and ECP (Enhanced Capability Port), are bi-directional, and offer even higher transfer rates. These enhanced operating modes require a parallel port and cabling that supports high speed, bi-directional operation. Most new PCI-based systems with communication ports populated directly on the motherboard include an enhanced parallel port.

Despite its current all-but-universal availability and high speed capability, the parallel port hasn't been embraced as a mainstream interface for test and measurement, although there is some data acquisition equipment with parallel interfacing. The reason for this lack of popularity may be as simple as the fact that the parallel interface's distance and speed capabilities are already duplicated or surpassed by other standards, such as USB and FireWire. Furthermore, parallel ports have been implemented in hardware in different ways, which can sometimes make it difficult to get parallel devices operating properly. Finally, the parallel port, like the ISA slot, may disappear from PCs altogether as printers and other parallel peripherals increasingly come with USB or FireWire interfaces.

## 2.4.3 IEEE-488 (GPIB)

The IEEE-488 bus was developed by Hewlett-Packard in 1965 as the "HP Interface Bus" (HP-IB) to provide a standardized communication interface for lab instruments, recorders, and related equipment. The interface proved to be both popular and versatile; it was ultimately renamed GPIB (General Purpose Interface Bus) by the IEEE. GPIB is also known generically as "IEEE-488," although the complete standard consists of the IEEE-488.1-1987 (hardware specification) and IEEE-488.2-1992 (a superset of IEEE-488.1 dealing with software and communication).

The GPIB has become an industry standard for an extremely wide range of electronic instruments, including data acquisition products. This 8-bit parallel bus transmits data at up to one megabyte per second. Up to 15 devices can be wired on one bus in either a daisy chain or star configuration. The maximum distance per cable drop is 6.5 feet (2m), although this distance can be extended to more than 6500 feet (2km) with repeater hardware.

GPIB interfaces generally aren't standard equipment on PCs, so a plug-in adapter board and appropriate driver software must be installed in the PC to communicate with GPIB instruments. These boards are available in ISA, PCI, and PCMCIA versions from most data acquisition manufacturers.

In 1992, some manufacturers of GPIB interfaces began to introduce a higher-speed version of GPIB that was eventually designated "HS-488." The proposed change offers increased bus speed at the expense of the robustness the standard IEEE-488 handshaking scheme affords. Opponents of HS-488 cite compatibility and interoperability issues, a marginal increase in practical throughput, and the availability of newer, faster buses as reasons not to tamper with the existing GPIB standard. Although HS-488 interfaces are now available, the standard hasn't been widely adopted. Further, with more than 20 years of development behind them, IEEE-488 interfaces and instruments have the advantage of an extremely large investment in business and academic applications. These instruments are not likely to be replaced soon, despite any advantages HS-488 offers.

#### **2.4.4 Universal Serial Bus (USB)**

The Universal Serial Bus (USB) was introduced in 1995 to address a number of connectivity issues associated with existing serial communication standards. USB supports multiple devices and provides easier installation, faster transmission speeds, and simpler cabling requirements than conventional parallel or serial ports. USB is also designed to supply modest operating power directly to peripherals, eliminating the need for external power supplies in some cases.

Many PCI-based Pentium PCs include one or two USB ports on the rear panel as standard equipment. Dual USB ports can support elaborate USB configurations, because external USB hubs can be attached to each port, allowing up to 127 USB peripherals to be connected. Hubs can be stand-alone devices or they can be built into keyboards, printers, or other USB peripherals. They can also include power supplies to drive USB peripherals.

USB operates at distances up to 16.5 feet (5m) per cable drop, with a maximum of 50 feet (15m). Maximum speed for USB version 1.1 is 12Mbits/second. However, the USB 2.0 standard released in 2000 raises the maximum USB speed to 480Mbits/second—faster than the first-



generation FireWire interface, but slower than that anticipated for future FireWire implementations.

USB peripherals are “hot plug” devices, so they can be attached or removed from an energized PC without damage and without the need to reboot. USB also incorporates Plug-and-Play, so a compatible PnP operating system will automatically recognize and reconfigure PC resources to handle the addition or removal of a USB peripheral. These ease-of-use features are among the strongest arguments for USB.

Two initial concerns with USB—operating system support and the availability of peripherals—have also been addressed. Successful USB operation requires that a PC contain USB hardware ports, operating system support, and driver support. Normally, all requirements can be retrofitted to a machine without USB support.

USB is fully supported by Windows 98, Windows Me, and Windows 2000. Some versions of Windows 95 also support USB. Microsoft's first-generation USB drivers are included in Windows 95 “OSR 2.1,” which was bundled with OEM computer systems, but not available for retail sale. There is no Microsoft USB support available for the original version of Win 95 or Windows NT. Although third-party USB drivers may be available for early versions of Windows 95, the simplest solution might be simply to upgrade the operating system to a later version that supports USB.

The list of USB devices available includes mice, keyboards, PC cameras, scanners, external modems, disk drives, printers, and speakers. Predictably, availability of USB data acquisition hardware has lagged, but it will undoubtedly increase as USB becomes more popular. Adapters are also available to mate conventional GPIB, serial, and parallel devices to USB.

#### **2.4.5 IEEE-1394 FireWire**

FireWire is a high-speed serial interface that's outwardly similar to USB. The technology was originally developed by Apple Computer for digital video, audio, and related high-speed applications, then proposed as a standard to the IEEE. In 1995, FireWire received the designation IEEE-1394 (sometimes shortened to “1394.”) FireWire offers high transmission speeds, simplified low-cost interconnects, and the ability to daisy chain up to 63 devices on one bus.

The current FireWire standard describes data rates of 100–400Mbits/second over distances up to 15 feet (4.5m). Speeds of a gigabit/second or higher are planned, and future enhancements are expected to extend the maximum transmission distance. Like USB, a FireWire device can be hot plugged and is Plug-and-Play compatible. Windows 98, Windows Me, and Windows 2000 contain drivers for FireWire. Windows 95 will not support FireWire, at least not through driver products offered by Microsoft. FireWire has replaced the SCSI

port on more recent Apple machines. FireWire ports are not yet common on PCs, so FireWire support must usually be added to current-generation PCs by using a plug-in adapter.

The FireWire cable and connector are outwardly similar in appearance to USB, although the two standards are neither physically nor electrically compatible. Cabling consists of dual shielded/twisted conductor pairs, plus two additional conductors to carry power to FireWire peripherals. Sony's "iLINK" is a variation on FireWire that uses only four conductors to carry signal. Power is not transmitted, but the signal protocol is essentially the same as FireWire.

FireWire has been embraced for applications in digital video (DV) and audio, which is not surprising, given that these are the traditional strengths of Apple machines. The technology is a natural fit for any application that requires moving large amounts of data at high speed, and is adaptable to virtually any type of peripheral. In comparing the speed of FireWire with USB, it appears that both standards will continue to leapfrog each other in order to gain temporary speed advantages. In the end, FireWire may prevail in speed, but may offer less in the way of distance and device support (63 vs. 127 peripherals). However, both buses are relatively new, and both may ultimately become standard equipment on PCs as complementary technologies.

As far as FireWire and data acquisition are concerned, there are few FireWire-compatible data acquisition devices at this writing. However, it is significant that FireWire apparently leads USB in being considered as a replacement for GPIB in test and measurement applications. Protocols have been developed for transmitting IEEE-488.1 and -488.2 messages and command/control sequences on a FireWire bus. This encourages the use of GPIB (SCPI) commands with FireWire.

#### **2.4.6 Distributed Measurements and Ethernet**

Many test and measurement applications require the ability to acquire data from separate stations located over a wide geographic area—larger than that is normally possible with plug-in boards or instruments that use traditional parallel, RS-232, or GPIB external buses.

Distances of more than a few feet between instrumentation and sensors can result in signal degradation, noise pickup, signal conditioning complications, measurement speed restrictions, and a variety of other problems. The nature of these limitations depends on noise in the environment, type and level of the signal, and length of cabling, among other factors.

There are two options for maintaining signal integrity where great distances separate the computer and sensors. The first is to condition and convert the signal at the sensor location to a form that won't be affected by adverse factors, then transmit the signal to centrally located test and measurement hardware. Common examples of this tech-

nique include conversion of signals to a higher voltage (0–5V or 0–10V), conversion to a current loop (4–20mA, 0–20mA), and conversion to frequency. The second method is to move the measurement instrumentation to the source of the signals, while continuing to use a centrally located computer. Communication signals between the instrumentation and the computer travel over a standard or proprietary bus, usually in digitized form. In this second case, the arrangement comprises a “distributed data acquisition system.”

There are advantages and disadvantages to each method of long-distance acquisition. Centralizing the test and measurement hardware eliminates the expense of duplicating measurement equipment at each sensor location. However, the hardware needed to transmit signals long distances back to the instrumentation and computer can offset some of the cost savings, and also complicates the setup.

With a true distributed system, data acquisition hardware must be included at each node of the system, resulting in higher overall system costs when compared to centralized test hardware. Communication between the computer and the hardware can use one of several standard communication protocols designed for error-free communication over extended distances. These distances extend to 4000 feet for RS-422 and RS-485 or around the globe for networked data acquisition.

Communication distances greater than 4000 feet can be achieved by combining data acquisition equipment with a network such as Ethernet. Network-based systems require installing a suitable interface in the PC and configuring the operating system for network support. These requirements are easily met using Ethernet, TCP/IP, and Microsoft Windows. Ethernet interface boards are inexpensive and readily available. TCP/IP is a nearly universal communication protocol for Ethernet-based systems that is supported by Windows and UNIX. Furthermore, most industrial data acquisition systems can be outfitted with a processor module containing an Ethernet port and Windows operating system. Ethernet adapters for GPIB and serial ports make it possible to assign an address to programmable instruments so they can communicate over a network.

A functional drawback of Ethernet data acquisition systems concerns real-time control. Like Windows, Ethernet is a non-deterministic system that precludes reliable, real-time process control. This can become even more of an issue when the World Wide Web is involved.

#### **2.4.7 Converters, Extenders, Repeaters**

Communication protocols include specifications of the distance over which reliable communication can be maintained. It is often possible to extend this distance by using external hardware to boost communication signal levels or to convert one protocol to another that can be transmitted over a longer distance. In other cases, a converter may sim-

ply allow two pieces of equipment with different interfaces to communicate with each other, with distance being a secondary consideration.

Common types of interfaces and converters include serial to IEEE-488, serial to Ethernet, and IEEE-488 to Ethernet. In each case, the user must determine whether using these devices achieves the desired goal more cost-effectively than another method. For example, a computer may contain RS-232 serial ports, while the application requires an instrument with IEEE-488 interface. The user must determine whether it is better to use a serial to GPIB adapter or to install an IEEE-488 interface board in the computer.



---

SECTION 3

Software  
Overview

---

## 3.1 System Software

Surveys indicate roughly 80 percent of test, measurement, and data acquisition applications are computer controlled. These automated test systems typically use PC-based data acquisition hardware and software. These two aspects are interdependent and equally important.

The best choice for data acquisition software for a given task depends on any number of factors, including computer platform, operating system, user programming skills, and application type. While some of these items are a matter of personal preference, others are dictated by conditions beyond the user's control, such as corporate policy, financial concerns, the need for compatibility with other software or hardware, etc. Operating systems and computing platforms other than Microsoft Windows® can be used successfully for data acquisition, but the full burden for program development, hardware control, and support typically rests with the user. Therefore, users who strongly prefer a non-Windows environment may still find that the economics and greater ease of system development encourage them to use Windows for data acquisition applications.

## 3.2 Open vs. Closed Programming Environments

Since the introduction of Windows 95, the general trend in PC software has been to make computing simpler, more graphic, and more accessible to users, without the need for users to have in-depth knowledge of application programming. However, this philosophy was associated with computerized measurement and control software well before Windows became popular.

### 3.2.1 History of Open vs. Closed Programming Environments

Prior to the introduction of the Windows environment, there were two fundamental types of data acquisition software. First, most data acquisition manufacturers supplied drivers and/or libraries for their data acquisition products. This software support added hardware control capability to popular, DOS-based programming languages such as interpreter BASIC, compiler BASIC, C, and PASCAL. Languages were text-oriented and presented little more than a command prompt from which the programmer had to develop all user interface, hardware control, data manipulation, and display functions. The programming environment was said to be "open" for several reasons:

- The program was developed by the end user, who had access to all the code.
- The user was free to distribute or modify the program as needed to provide new features or even to operate with different hardware.

- Commercial software developers might also develop software tools that could coexist with the user's selected programming language and hardware.

Alternately, a user could opt for a proprietary, closed-architecture package designed to automate hardware control, data manipulation, graphing, analysis, and other functions. Such packages were also DOS applications, and were normally purchased with drivers or libraries supporting a specific manufacturer's data acquisition products. Other than the ability to develop end applications, the user had little control over how the software operated. Copyright restrictions meant that a program developed on one computer might not be shared legally with other users unless a "runtime" license was obtained for other computers.

Proprietary software packages were generally developed by third parties who did not manufacture test and measurement hardware, so support for new hardware could lag the introduction of the hardware. While the libraries and drivers that were offered by hardware manufacturers were usually free, proprietary packages could be quite expensive.

Proprietary, closed-architecture packages have classically been associated with the concept of "no programming." Users generate test programs with tools such as pull-down menus and fill-in-the-blank forms. Although the user might be insulated from conventional programming, there is still a learning curve associated with closed software environments, and the total effort required can equal that of using an open programming language.

### 3.2.2 Open vs. Closed Programming Environments Today

Today, the dominant PC operating system is some version of Windows (95/98/Me/2000/NT), rather than DOS. The majority of software packages are Windows applications, and the most popular data acquisition programming languages are now Visual Basic®, Visual C/C++®, C++Builder™, and Delphi™. Many test and measurement hardware manufacturers provide Windows-compatible ActiveX® controls, Common Object Model (COM) objects, and other programming tools to facilitate program development using these languages. New proprietary packages have also been introduced, such as LabVIEW™, Agilent (formerly HP) VEE®, and TestPoint™. While these programs are similar in scope to DOS-based test and measurement packages, they are Windows applications.

Despite the new data acquisition software options available, the important question of whether to use a programming language or select a proprietary package to develop test software remains open. In some cases, a program development environment may not be needed at all for relatively simple applications. The start-up software supplied



with some data acquisition boards and instruments may be sufficient for simple test needs.

Open architecture programming languages have become simpler to use, while offering much greater versatility and power. Visual Basic and Visual C/C++ have emerged as the leaders for development of test and measurement programs. ActiveX technology simplifies programming without compromising performance; it also protects the investment in software development by making applications more portable. Conversely, a proprietary development package may be suitable for less complex applications where there's only an occasional need for program development.

Assuming that the application is to be developed in a Windows environment and that it requires more than simple data collection, an examination of the following criteria may be helpful in choosing an appropriate software approach:

- Learning curve
- Text-based vs. graphical syntax
- Programming efficiency
- Windows messaging and event management
- Debugging
- Application deployment

### **3.2.2.1 *Learning Curve***

Data acquisition software has benefited from the evolution of Windows as a simplified, graphical environment. As a result, the user interfaces of programming languages have become more visual in nature. Further, instrumentation products frequently use ActiveX and COM technology, which can simplify hardware control and other programming tasks. Therefore, language-based programming now approximates the look and feel of proprietary software packages more closely, and the total amount of effort needed to learn programming and develop programs has been reduced. Language-based programs also allow programs to be optimized and tailored more closely to applications than might be possible with proprietary packages. User-developed software components often can be recycled for new programming tasks, reducing development time.

### **3.2.2.2 *Text-Based vs. Graphical Syntax***

The interface a software package presents to the user can be text-based or graphical in nature. DOS and DOS-based programming languages such as interpreter BASIC are classic examples of text-based software. Windows and Windows-based programming languages provide varying degrees of graphically based software in which objects can be dragged and dropped or processes can be connected by drawing sim-

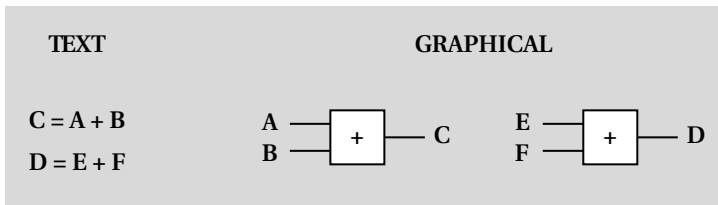

*Figure 3-1. Text-based programming vs. graphic-based programming.*

ple lines (wires) from one icon to another. Although Visual Basic and Visual C/C++ are graphics-intensive, they are still considered text-based languages because the code behind the Graphical User Interface (GUI) is written in text format.

The issue of choosing between text-based or graphics-based software revolves around which method is the most intuitive and easy to learn. The answer is mostly a matter of personal preference. For example, text-based programming has a top-to-bottom organization that is similar to the English language. On the other hand, graphical syntax can be considered more intuitive and easy to remember because it is based on pictures rather than alphanumeric characters. Further, the wires and icons approach is less susceptible to typing errors and other syntactical errors that can occur in text-based languages.

The top-to-bottom organization of text-based programming is invalid in a graphical language, so there must be another method to establish the order in which instructions are to be implemented. In the text-based example in **Figure 3-1**, “ $C=A+B$ ” executes before “ $D=E+F$ .” The graphical method requires an additional wire connecting both “+” icons to accomplish the same thing. In LabVIEW, this wire is referred to as “artificial data dependency” and its only purpose is to establish the execution order.

Program documentation is another issue to consider when choosing between text- and graphic-based programming. Documentation is more or less automatic in text-based programming because the program can be printed with non-executing comments to explain lines of code. In the graphical method, wires and diagrams may be difficult to consolidate on a printed document. This complicates documentation, which may become quite tedious in a long and complicated program.

### 3.2.2.3 Programming Efficiency

Program execution speed and response can be important, even critical, to the success of a test and measurement application. Typically, a proprietary programming package adds extra software to a basic data acquisition engine to provide simplicity and automation for the user. Every current proprietary development package is itself a Windows application, typically written in a C/C++ environment. This architec-

ture places additional software layers between the application software and the hardware. The extra overhead that results can affect the ability of the program to perform satisfactorily in critical applications. This typically shows up as less-than-optimum execution latency, multi-threading, and control over thread priority. Although there are Windows tools that can help optimize a program, they may be hidden by additional layers of abstraction in proprietary programming methods.

Another point to consider is that proprietary programs are developed for a broad range of users, so a broad range of functions must be built into the package. At the same time, code must be limited where possible to keep the programming job manageable. As a result, some data acquisition tools or Windows services might be excluded from the software or the full range of functions available in a given hardware product might not be available. That means the software may have significant limitations or may fall short in the future. In contrast, a customized test application developed in an open environment can be limited to only the data acquisition tools and Windows services required for the job, then expanded as needs change.

#### ***3.2.2.4 Windows Messaging and Event Management***

Messages and events are the processes by which Windows manages its multitasking system and shares keyboard, mouse, and other resources. This is done by distributing information to applications, application instances, and processes within an application. Typically, proprietary packages don't make efficient use of Windows events and messages. By contrast, events are the fundamental element of the Visual Basic programming environment.

For example, consider a data acquisition application running in the background. With event-driven processing, the application can use the CPU for additional tasks, such as database or network access rather than constantly status-polling to determine if data are ready for collection. When data are available, a device driver notifies the application by sending the proper event or message through Windows.

This tight coordination between data availability and CPU execution means that programs written for event-driven processing are robust and portable across computers of vastly different CPU speeds. If an application was developed with Visual C/C++ and ran successfully on a 100MHz Intel Pentium® processor, there's a high probability it will run on a 433MHz Celeron™ processor. This may not be the case for an application developed with a proprietary package, especially if it employs simple, time-sensitive loops or other polling approaches.

### 3.2.2.5 *Debugging*

Efficient debugging is critical to the success of a software development project and limited debugging tools may increase development time and stall progress. The component-based architecture of today's open programming systems simplifies software development and debugging. Extensive and powerful debugging tools are available with Visual C/C++ and Visual Basic.

### 3.2.2.6 *Application Deployment*

Application programs are sometimes created by software developers, then distributed to end users. Deployment can be problematic for applications developed with proprietary packages because the user does not have the development package. The difficulty lies in the runtime program that is part of the proprietary layer. Deployment is much less of a problem with COM-based applications because the compilers are smaller and more efficient, and the runtime library is usually part of Windows.

## 3.3 **Software Development under Windows**

To create a successful system, the interaction between the hardware and software must be well understood, and application programs must be developed for optimum results with them. This task is especially challenging in the present environment due to rapid changes in PC hardware, operating systems (OSs), communication buses, and software development tools.

Preventing problems requires application development planning based on a knowledge of software structure. These principles will apply to PC-controlled systems using both plug-in boards and stand-alone instruments with GPIB (General Purpose Interface Bus, also known as IEEE-488), USB (Universal Serial Bus), and other digital communication buses.

### 3.3.1 **Software Structure Overview**

Typical automated test application software can be represented as a series of layers (**Figure 3-2**). In the Windows operating environment, the test application communicates directly with the Application Programming Interface (API) and device drivers to control the test and measurement hardware devices.

### 3.3.2 **Device Drivers**

A device driver is the software interface between a computer's operating system (such as Windows) and any data acquisition plug-in board, GPIB instrument, or communication interface attached to the computer. The driver is the abstraction layer that shields the program developer from the complexities of a hardware device. All the com-

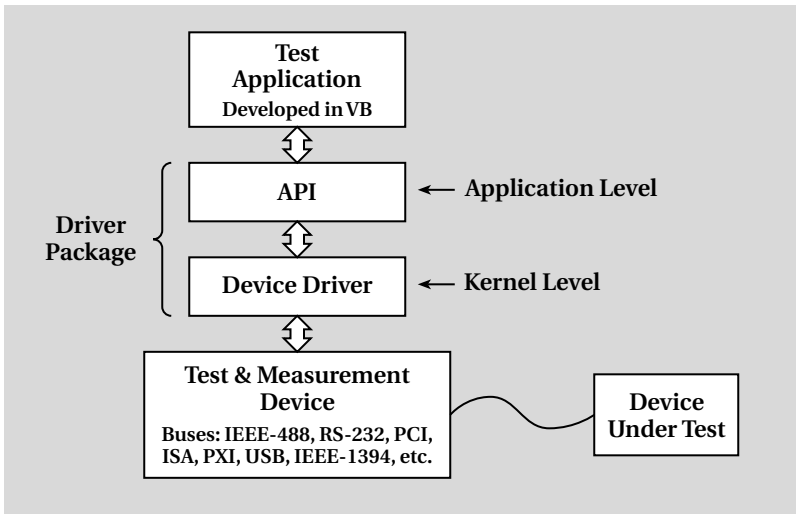

Figure 3-2. API software structure

mands to and from the hardware are ultimately executed by device drivers. Therefore, they are key elements in both the development and implementation of test application software.

Let's examine the role of a driver in more detail. Much like a printer or mouse device driver, a data acquisition driver is essential to the hardware's operation. It permits communication with the data acquisition device. The PC subsystems that each hardware device needs to use, such as RAM and I/O addresses, are protected by the operating system (OS). A user cannot communicate directly with these subsystems, but requires a device driver that acts as mediator between the test application and the OS kernel. (The kernel is a set of OS programs that implement primary system functions).

This layered architecture provides robustness, portability, maintainability, flexibility, and other features and requirements that computer users demand. Imagine if the OS didn't prevent direct access to its sensitive areas, and device users had to write their own protocols to gain access to hardware functions. Such an OS would be intolerable. Oddly, the pre-Windows DOS operating system behaved in much this way. Most programs written for DOS included mouse, video, printer or other specialized drivers designed to work only with that software.

### 3.3.2.1 Driver Development

A Windows device driver is written in Microsoft Visual C/C++ and is a special extension of the core OS. A device driver (typically a .SYS file) is executable code that loads in the PC's RAM. Device drivers receive

more attention, flexibility, and full unprotected access to the system memory and hardware. As such, device drivers must follow very specific rules and guidelines for interfacing with the rest of the OS. The Windows Driver Model (WDM) is the latest specification by Microsoft for coding common binary device drivers that are compatible with Windows 98 and Windows 2000.

The multitasking, multithreading, and multiprocessing of today's PCs further elevate the role of device drivers. A device driver should, at a minimum, handle the most likely multitasking scenarios that could affect operation of its hardware device. Since a typical PC has many drivers running (such as video, mouse, printer, keyboard, networking, and disk controllers), each driver should ideally be designed to coexist with all other drivers, to be robust (i.e., crash-resistant), and to consume a minimum of memory, processing time, or other system resources.

Developing a robust device driver is challenging because of the sensitive interrelationship between it and the OS, as well as the virtually unlimited variety of multitasking conditions where it might be used. Developing a good device driver requires intimate knowledge of both the hardware device and the OS software. Many Windows crashes are due to unpredictable conflicts and malfunctioning device drivers.

### **3.3.2.2 *The Evolution from DOS to Windows***

The replacement of DOS by the Windows operating system, plus today's increasingly complex test systems, have placed greater demands on software and its development. Under DOS, programming a device was relatively easy. A given program would usually have full control of the computer and only had to do one task at a time. Direct access to the I/O address space was available with relatively simple commands in C language (inp and outp) or BASIC (peek and poke).

With the multitasking paradigm of Windows, Microsoft had to establish a new set of rules for managing communication with peripheral devices. A Windows driver is no longer just a single .EXE file that is loaded in memory or copied to a special directory.

Rather, it is a package of many files, such as .INF, .SYS, .VXD, .DLL, .EXE, and .LIB files, for example. These require a specific installation process, which might include modification of the Windows registry, implementation of Plug-and-Play, power management setup, and resource management, to name only a few. This process isn't just a matter of copying files to a hard drive; it is an algorithm that handles the different versions of Windows appropriately, including Windows 95 (versions a, b, c), Windows 98 (first and second edition), Windows Me, Windows NT (SP1 to SP6), and Windows 2000. When Windows is upgraded from one version to another, it can easily affect driver installations. It's expected that device driver developers will follow suit and upgrade installations as necessary.

A test and measurement application may simultaneously acquire data from multiple devices, control a process, graph data, save it in a database, and make it available on the Internet. The more demanding the test requirements are, the greater the complexities of PC-based test systems will be. This in turn imposes more conditions on the drivers and other system software. In most cases, it will not be necessary for a programmer to develop the necessary drivers because they will be available from hardware and software suppliers, and can be interfaced by the application program.

### **3.3.3 The Application Programming Interface**

When creating an application program, a developer sees and interacts with the Application Programming Interface. The API greatly simplifies common tasks the developer performs with the hardware and makes communications between the device driver and the test application transparent. The API acts as liaison between the device driver and the test application, so end users rarely have to communicate directly with a device. Therefore, it's important for a driver developer to know how users will program or configure the hardware device before building the driver foundation under the API.

The API typically is part of the driver package. It should be the first piece designed when developing a device driver. The ActiveX control interface is an example of an API, which plays a significant role in simplifying development of test programs for data acquisition and other applications. Other types of APIs include COM objects, DLLs, libraries, and support modules for Visual Basic, Visual C/C++, and other programming languages.

#### **3.3.3.1 *The Role of an API***

From its definition, it follows that the API can be a major factor in obtaining results from a test application. For example, streaming digital data to disk at 100kHz requires not only high-speed data acquisition hardware, but also proper API tools to take advantage of this speed by transferring data efficiently. Similarly, logging temperature data accurately requires not only good measurement techniques and cold-junction sensors, but also a cold-junction compensation algorithm in the API. Ideally, the software automatically supports hardware features. However, both developers and end-users need to pay close attention to the features offered by the API and its possible limitations.

#### **3.3.3.2 *Hardware Independence***

Hardware independence is an important feature of the ActiveX API mentioned previously. This factor has the potential to increase the longevity of test application software. Given fast-changing PC technology and the frequent obsolescence of data communication hardware, it's also a critical cost issue. For example, consider how quickly the

transition from RS-232 to USB and FireWire is occurring. The degree of portability of an API helps determine whether the software will have to be rewritten with every hardware upgrade.

### 3.3.3.3 *ActiveX Controls*

Although a device driver must change with a significant hardware change, the API exposed to the user doesn't have to change, especially if it is ActiveX-based.

ActiveX is a set of rules governing how different applications or software components should interact and share information in the Windows environment. Developers have been shifting rapidly to component-based software architectures, so ActiveX controls are among the most important features in an API.

An ActiveX control (formerly known as an OLE or OCX control) is a user interface element that takes advantage of the standards for information exchange and functional modularity among Windows-based applications. ActiveX controls are based on Component Object Model (COM) technology, a software architecture that allows building applications from software components.

COM technology provides many benefits, including easier integration, scalability, and reusability, as well as language independence, cross-platform compatibility, and context-sensitive help.

### 3.3.3.4 *The Benefit of ActiveX*

A major benefit of ActiveX is its use of a single, simple object to replace many lines of code for common functions. This lets programmers create reusable software components that can be interchanged without the need to rewrite entire applications. Interchangeability reduces development cost and extends the life of an application.

For example, an application originally written for a 16-channel 100kHz analog I/O board could be used with a 64-channel 300kHz analog I/O board simply by replacing an ActiveX control that describes the characteristics and functionality of the data acquisition device.

The following snippet of code uses three different ActiveX controls. ActiveX1 acquires the data from the measurement device, ActiveX2 performs the analysis, and ActiveX3 graphs the data.

```
Data() = ActiveX1.Acquire_Data( Channels() )
Analysis() = ActiveX2.Spectrum( Data() )
ActiveX3.Chart( Data(), Analysis() )
```

This code shows the simplicity of programming with ActiveX controls. In this component-based open architecture model, each of the ActiveX controls is an independent entity, which could be supplied by more than one vendor.



Test and measurement manufacturers and third parties have developed thousands of ActiveX controls, which strongly support the concept and benefit of open architecture software systems. These properties of ActiveX and its underlying model protect the user's software investment by making applications more portable and simplifying hardware upgrades. For instance, DriverLINX® is a standard data acquisition software driver for Keithley's data acquisition hardware. Its design is based on the common object model; therefore, it is truly hardware independent across all Keithley's boards.

While it's natural for a given test and measurement vendor to maintain the same driver interface and syntax across all its hardware and languages, software reusability is particularly challenging when using multiple vendors.

### 3.4 FIFO and Buffer Overrun Issues

A FIFO (first-in, first-out) is a temporary memory storage block found on almost every data acquisition device. A FIFO memory operates on the "First In, First Out" principle, and can serve as the on-board memory where data are stored before being retrieved by the device driver (**Figure 3-3**). When a sample is read out of a FIFO, its space can be used by incoming data. To make data-streaming more efficient, a FIFO typically asserts an interrupt when it is half-full, signaling the device driver that it's time to retrieve data. At that point, the driver launches an Interrupt Service Routine (ISR) to read the data and wait for the next interrupt.

FIFOs were designed to compensate for software and OS latency in order to help prevent loss of data. For example, when a program streams data to a hard drive, the FIFO helps keep sequential data contiguous while the application writes it to disk. However, during FIFO use, there is a race going on between the data intake and data output read by the device driver. Ideally, in order to avoid a buffer overflow condition, the Data-out speed should be faster than the Data-in speed. If the FIFO fills up faster than the driver can retrieve its output, a buffer

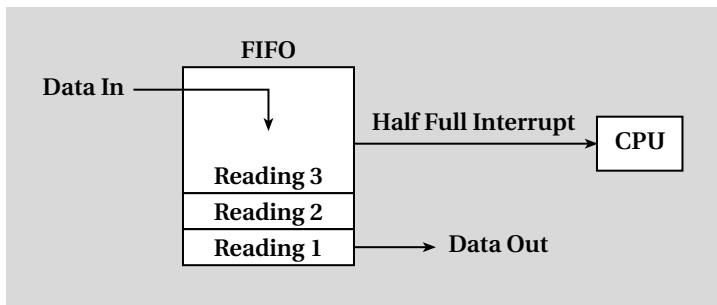

Figure 3-3. FIFO operation

overflow) error occurs. Incoming data has no place to be stored, so it is lost.

### 3.4.1 The Role of DMA

Direct Memory Access (DMA) is a means of performing I/O without involving the computer's CPU in the transaction. Bypassing the CPU permits direct data transfer from the data acquisition device to memory. The advantage this offers is greater throughput.

During a DMA transfer, the CPU can be used for other tasks without affecting the data transfer speed. Typically, a complete set of data is acquired by initiating multiple DMA transactions of 64 kilobytes. At the end of each DMA transaction, an ISR is generated and is handled by the device driver. Multiple DMA transactions can also be chained, making the process even more efficient by reducing the number of ISRs. There are two styles of DMA design. "Bus Master DMA" is used with the PCI bus, while "System DMA" is used with the ISA bus.

With Bus Master DMA, all the control circuitry necessary to initiate a DMA transfer exists on the PCI board. With System DMA, the support circuitry is on the motherboard, shared among all ISA peripherals. Bus Master DMA is much more efficient, and the PCI bus operates at a much higher data transfer rate than the older ISA bus.

In either case, DMA requires critical coordination between hardware and software. The hardware must have the proper circuitry, and the software must implement the proper procedures for successful DMA operation.

### 3.4.2 Polled vs. Event-Driven Control

In a polled system, the computer checks many devices to see if they're ready to send or receive data. In the context of a data acquisition system, this typically involves reading or writing a single value from or to a data I/O channel. In a Windows-based PC, the time between polled readings is scheduled by Windows, so it's nondeterministic. In other words, the time at which Windows will initiate an operation cannot be known precisely. Its operation can depend on any number of system factors, such as computer speed, operating systems, programming languages, and code optimization.

By way of comparison, a deterministic data acquisition system is one that collects data having discrete values, and direct cause-and-effect relationships with the physical phenomena they represent. This implies a strong time relationship between the data and the underlying phenomena.

Typically, data acquisition running in the background, using DMA- and ISR-driven operations, is under the control of the data acquisition hardware. The data acquisition hardware notifies the user's application when the task is complete. The time between background readings is

clocked by the data acquisition hardware and is independent of Windows timing.

During a background data transfer, the data acquisition hardware interrupts the CPU. The driver handles these interrupts by transferring data into the application memory space. When the requested background operation is finished, the driver posts a Windows message or event to the application, which responds to the event and manipulates the data. Events and messaging are the processes Windows uses to distribute information to applications and processes within an application, thereby managing its multitasking system. Event-driven programs result in a more deterministic system.

An application that uses polling is simple to program. Polling can be appropriate with slower, non-time-sensitive operations, such as programming discrete steps in a power supply's output or reading precise voltages from a nanovoltmeter.

Trying to squeeze high speeds out of a polled application will probably lead to less than acceptable results. In applications that use high speed data acquisition boards for faster sampling rates, event-driven programming is advised. Event-driven programming schemes are less dependent on OS timing, reducing latency problems.

### 3.4.3 Tight Control

A programmer can take advantage of Windows events and messaging by using Visual C/C++ and Visual Basic programming tools to create a deterministic application that runs fast and provides tight control. Rather than constantly status polling to determine if data are ready for collection, such programs can use the CPU for additional tasks such as database or network access until interrupted by the data acquisition hardware.

This tight coordination between data availability and CPU execution also makes event-driven applications more robust and portable across computers of vastly different CPU speeds.

The hardware deployed for real-time applications in Windows is important. Event-driven programming may be necessary, but is not necessarily sufficient for some real-time applications. Contrary to what the words might indicate, real time tends to be a relative term, the meaning of which varies with the application and user requirements. In some applications, users consider a response time of 100 milliseconds to be a real-time response. In a different setting, a one microsecond response might be needed. The Windows operating system, whether it's Windows 95, 98, Me, NT, or 2000, isn't well suited for fast, real-time applications.

Real-time applications tend to work better with dedicated operating systems running on embedded processors. This implies instrument

or data acquisition hardware equipped with a digital signal processor (DSP) or microprocessor. The DSP or on-board processor performs many of the functions that would otherwise be performed by the computer's CPU.

The dedicated DSP or CPU approach eliminates problems associated with Windows running tasks in the background that aren't under a user's control. These background tasks use up CPU clocks and interrupt requests, so the test application must share these system resources. Some applications will actually perform better when programmed and run on a DOS system, particularly if the hardware and software were designed around that OS in the first place.

The design of every operating system (Windows, DOS, Linux, etc.) attempts to balance several conflicting demands, but tends to be optimized for certain types of tasks. A test system developer must weigh these tradeoffs. The ultimate selection will invariably involve compromises between flexibility, functionality, ease of use, robustness, and reliability.

#### **3.4.4 Managing Speed and Accuracy Tradeoffs**

Throughput is an issue in most production test applications, so a developer must look for programming techniques that speed up processing while maintaining accuracy. In particular, the programmer should avoid an error that can occur when using a PC that is much faster than the instruments attached to it. In this situation, the user may gain a false sense that the system is faster than it actually is, which can lead to inaccurate test results. This problem arises because the application software outpaces the hardware. Sometimes, the hardware driver package will take care of these timing issues; in other cases, the user must make adjustments in the application program as outlined in the following example.

In a typical production calibration system, the application program commands the calibrator to apply a certain voltage stimulus to the device under test (DUT) before measuring its response. Both the calibrator and DUT need a certain amount of time, often seconds, to settle to the required state (stimulus or response) before the program commands a measurement. If that amount of time isn't accounted for in the program, the calibration process will be inaccurate.

Typically, programmers hard-code wait times, so this isn't an issue. However, in production tests where throughput is critical, there's a downside: the wait time may be longer than is actually needed.

Rather than hard-coding a specific wait time, the programmer can create an algorithm that uses feedback from a calibrator (an instrument-ready bit) to acknowledge that the stimulus voltage level has been reached. This means the program can proceed to the DUT response measurement. The measuring instrument can provide a sim-

ilar signal after it has acquired the data following a delay, based on its own internal program. This kind of programming approach results in higher production rates.

---

SECTION 4

Basic Component  
Theory

---

## 4.1 Introduction

This section of the handbook provides an overview of the types of electronic components used in data acquisition. It's intended to help users understand and work with components used in the construction of test setups, to give users insight into data acquisition hardware so they can understand analog and digital measurements concepts, and to help users optimize their test procedures.

Test and measurement systems are developed and operated in a variety of ways, ranging from a single individual to a team of system integrators, programmers, system maintenance staff, and operators. These people often have widely varying degrees of technical expertise and specialization. This section assumes that the reader is familiar with the concepts of voltage, current, and resistance, and the mathematical relationship between them.

## 4.2 Passive Components

Ideally, a sensor or signal source can be connected directly to an instrument or data acquisition board input without the need for specialized signal conditioning. In practice, it is often necessary to add passive components (resistors, capacitors, inductors, or diodes) to a circuit to remove noise, alter signal levels, or achieve some other goal.

### 4.2.1 Resistors

The function of a resistor is to impede the flow of electric current. Resistance is measured in ohms ( $\Omega$ ). The most important characteristics of resistors are resistance, power handling ability, and construction. These factors are interrelated and most often mutually exclusive. For instance, it may be difficult to find a resistor that combines very high resistance and very high power handling ability; such a device might be prohibitively large or expensive. Some types of resistors are more sensitive than others to signal frequency or ambient temperature.

Resistors are manufactured with several basic techniques. The resistive element can be molded from a mixture of carbon and clay or deposited as a resistive film on an insulating substrate. Alternately, a resistive wire can be wound on a suitable form. Varying the thickness, length, or composition of the resistive element allows the manufacturer to control resistance and other properties. The complete package can be made in a variety of forms and sizes with different styles of wire leads or no leads at all in the case of surface-mount devices.

The general differences in resistors manufactured with these techniques are summarized in **Table 4-1**. Note that the information is typical and may vary considerably from one manufacturer to another. Also note that some characteristics may be less relevant for certain applications.

*Table 4-1. Resistor characteristics – film vs. wirewound*

Characteristic	Composition or Film Resistors	Wirewound Resistors
<b>Value</b>	Approx. $0.5\Omega$ to several million ohms.	Approx. $0.05\Omega$ to several thousand ohms.
<b>Accuracy</b>	$\pm 0.1\%$ to $\pm 5\%$ . Technology supports laser trimming and other techniques to achieve high accuracy.	$\pm 0.1\%$ to $\pm 5\%$ .
<b>Power Handling</b>	Up to 5W.	1W to 100W.
<b>Frequency Effects</b>	Performance generally independent of frequency unless film has been deposited on the substrate as a spiral.	Wound construction can result in inductive effects for AC signals.
<b>Relative Physical Size</b>	Smallest. Includes “chip” resistors used in miniaturized products.	Medium to large.

#### 4.2.1.1 Resistor Applications

Resistors are generally used to limit current, reduce voltages (as when multiple resistors are configured as voltage dividers), or act as shunts for current measurement. Example circuits are shown in **Figures 4-1** through **4-3**, along with pertinent formulas. These applications are typical of data acquisition.

##### *Example: Current Limiting*

The example circuit (**Figure 4-1**) demonstrates the use of a resistor to limit current through a device that would otherwise be destroyed by excess current. The light emitting diode (LED) is shown powered from a 5V battery, but power could also be supplied by a source of voltage in a data acquisition system. A typical LED will turn on at about 0.7VDC; higher voltages will result in progressively greater current flow and intensity. If not limited, current can exceed the safe operating limit of the diode.

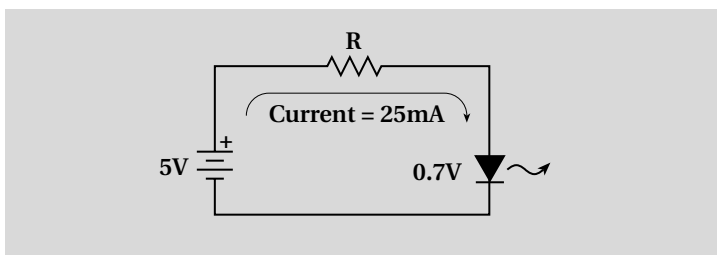

*Figure 4-1. Current limiting*



In this example, the voltage drop across the LED is 0.7V, leaving 4.3VDC (5.0 minus 0.7) dropped across resistor R. The desired current is 25mA, so the value of the resistor can be calculated using Ohm's Law:

$$R = V / I$$

$$R = 4.3V / 0.025 A = 172\Omega.$$

A 172 $\Omega$  resistor may be difficult to find, and the value is not critical. A slightly higher standard value of 180 $\Omega$  will do nicely. To be safe, it's important to check the power to be dissipated by the resistor:

$$P = V \times I$$

$$P = 4.3V \times 0.025 A = 0.1075 \text{ watts.}$$

Resistors are available in a variety of power ratings, including 0.125 and 0.25 watt types. Either would work in this application. The 0.25W type would provide some margin of safety.

#### *Example: Voltage Division*

**Figure 4-2** shows resistors used to scale down a voltage to a value compatible with existing measurement hardware. In this case, a signal with a maximum amplitude of 36V must be measured with an A/D board with an input limit of  $\pm 10V$ .

For this example, assume that the signal has a low source impedance, which is represented by the resistor symbol in the "Signal Source" box. Source impedance is an important concept that appears often in test and measurement applications. For a complete discussion, see Keithley's reference handbook, *Low Level Measurements*.

Briefly, any voltage source can be thought to include a resistance through which the generated current must flow (**Figure 4-2**). This resistance, which is called the "source resistance" or "source impedance," is expressed in ohms. At a given voltage, current compliance varies

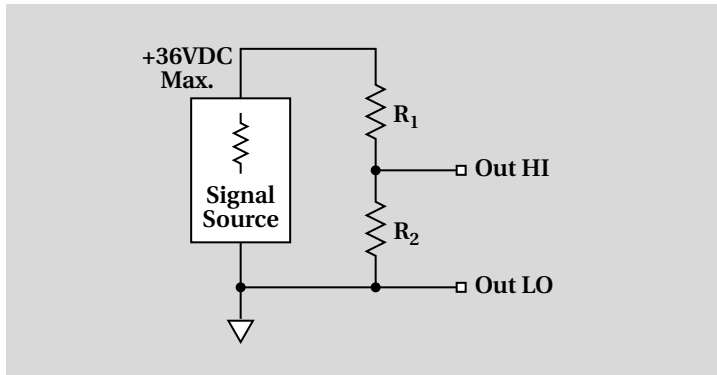

*Figure 4-2. Voltage divider*

inversely with source resistance. When a voltmeter is connected to a voltage source, a small current flows from the source into the meter to facilitate the measurement. Ideally, any voltage measurement instrument will minimize this current to avoid loading down the source. Most data acquisition A/D inputs offer an input resistance on the order of several megohms to hundreds of megohms, which is sufficient for voltage measurements from ordinary sources and transducers, but may be inadequate for sensitive measurements of high impedance signals.

In the case of the example circuit, assume a source impedance of less than  $100\Omega$  for the signal source and an input resistance for the data acquisition board of  $100M\Omega$ . This means that a total resistance of a few hundred kilo-ohms for the voltage divider  $R_1 + R_2$  should give good results. Therefore, let's assume a value of  $100k\Omega$  for  $R_2$ . This could as easily be  $10k\Omega$  or  $500k\Omega$ . In a real-world application, the goal of selecting a value would be to avoid loading down the source while providing a signal that the A/D input will not load.

The voltage ratio that needs to be produced by the divider is  $10V/36V$  or  $0.2778$ . The formula for calculating the resistors in the dividers is:

$$\begin{aligned}\text{Voltage Ratio} &= (R_2) / (R_1 + R_2) \\ 0.2778 &= 100,000 / (R_1 + 100,000) \\ 0.2778 \times (R_1) &= 72,220 \\ R_1 &= 259,971\Omega = 259.971k\Omega\end{aligned}$$

Obviously,  $259.971k\Omega$  is not a standard resistor value. A slightly higher value  $270k\Omega$  resistor would work well and result in slightly less than  $10V$  out when the sensor produces  $36V$ . A full scale output of less than  $10V$  is preferable to avoid applying a voltage to the A/D input that is outside its range.

The actual output when  $R_1 = 270k\Omega$  and  $R_2 = 100k\Omega$  would be:

$$\begin{aligned}\text{Output} &= 36V \times (100,000) / (100,000+270,000) \\ \text{Output} &= 36V \times (0.2703) \\ \text{Output} &= 9.73V\end{aligned}$$

The actual voltage ratio is  $0.2703$ , which can be used to scale the reading back properly to  $36V$ . For example, a reading of  $6.8V$  would correspond to  $6.8/0.2703$  or  $25.157V$ .

### ***Example: Current Measurement***

A third example of using resistors in data acquisition is as a sensing resistor to facilitate current measurements. Few data acquisition boards can measure current directly. However, it is a relatively simple matter to send the current through a resistor, then measure the voltage drop across the resistor.

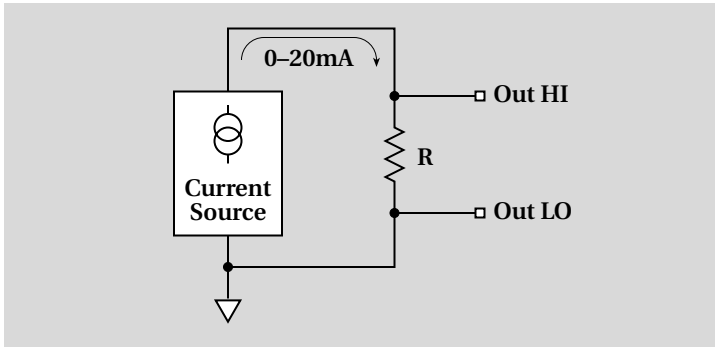

Figure 4-3. Current shunt

In **Figure 4-3**, the transducer's output is a current ranging from 0 to 20mA full scale. The transducer will act to adjust its output voltage to force a specific current through the circuit, regardless of cable length and the value of the current sensing resistor ( $R$ ).

As with the previous voltage divider example, the circuit should be set up so that the maximum voltage developed across the resistor is compatible with the A/D input range. A resistor of  $499\Omega$  will cause a voltage drop of  $499 \times 0.020$  or 9.98V. This voltage is ideal for a 16-bit A/D set for an input range of 0 to 10VDC. A  $249\Omega$  resistor will produce a drop of  $249 \times 0.020$  or 4.98V, which is suitable for a 0–5VDC A/D input.

Note that current-to-voltage conversions such as this are only valid if the current source can generate the voltage needed to force the desired current through the circuit. For example, if the dropping resistor ( $R$ ) plus other resistances in the circuit total  $600\Omega$ , and the current source cannot reach a voltage greater than 10V, the source will not be able to force 20mA through the circuit ( $20\text{mA} \times 600\Omega = 12\text{V}$ ). A lower resistance would have to be chosen for  $R$ .

#### 4.2.2 Capacitors

A capacitor stores electrical energy in the form of an electrostatic field. The general mechanical principle of the capacitor is two conductive surfaces (plates) separated by a dielectric (typically an insulator such as Teflon®, polystyrene, or Mylar® polyester film). Capacitance is directly proportional to the total shared surface area of the plates, and inversely proportional to the distance between them.

Capacitors are manufactured using a variety of construction techniques and materials. This can cause capacitors of identical capacitance value to differ in other electrical properties, making one type or another more suitable for certain applications. Some of these characteristics are listed in **Table 4-2**.

*Table 4-2. Capacitor characteristics*

<b>Characteristic</b>	<b>Variation</b>
<b>Polarity</b>	Some types of capacitors, notably electrolytics and tantalum capacitors, are polar. One terminal is marked “+.” Polarity must be observed for proper operation and to avoid possible damage.
<b>Working Voltage</b>	Working voltage should at least equal the highest voltage occurring in a circuit. However, it is of no benefit to use a capacitor with a working voltage much higher than that which will be applied in the application.
<b>Frequency</b>	The construction of some capacitors results in their conductors exhibiting inductive effects that can become significant at higher frequencies. Such capacitors are less suitable for bypassing and noise filtering.
<b>Leakage</b>	An ideal capacitor with perfectly insulating dielectric would retain a charge indefinitely, and also not dissipate any power as heat energy. In practice, a charged capacitor will gradually lose its charge, although it may take quite some time for this to occur. Leakage is important in sample-and-hold circuits where a capacitor may have to retain charge for a long time.
<b>ESR</b>	Equivalent Series Resistance – A real-world capacitor can be thought of as a pure capacitor in series with a resistance that results from leads, materials, and other physical attributes of the capacitor. This resistance is called the “ESR.”

The engineering unit used to define capacitance is the farad (F). A farad is an impractically large capacitance for typical electronic circuits; therefore, it is more common to find capacitors with values of microfarads ( $\mu\text{F}$ ), nanofarads (nF), and picofarads (pF)—a range of  $10^{-6}\text{F}$  to  $10^{-12}\text{F}$ .

Working voltage is a second parameter associated with capacitors. A capacitor is designed to provide the rated capacitance at a specific voltage. Exceeding this voltage can destroy the capacitor.

A third characteristic of capacitors is Equivalent Series Resistance (ESR). A perfect capacitor would exhibit only capacitive properties, but a practical capacitor behaves more like a pure capacitance in series with a pure resistance, and in some cases, a pure inductance (**Figure 4-4**). Together, the resistance and inductance can be responsible for energy being lost in the capacitor or they can interfere with the capacitor’s ability to store or empty a charge. For some frequencies or applications, these factors can overwhelm the capacitive properties.

When a capacitor is connected to a DC source, a momentary current surge occurs as positive and negative charges build up on the plates and stabilize. Otherwise, the capacitor does not conduct DC

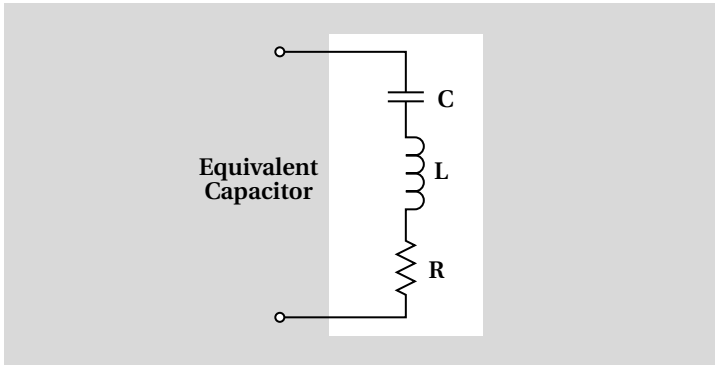

Figure 4-4. Equivalent capacitor

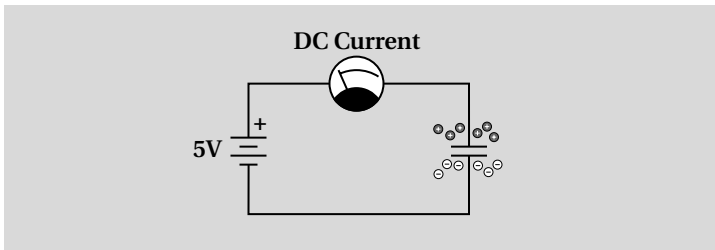

Figure 4-5. Capacitor connected to a source of DC

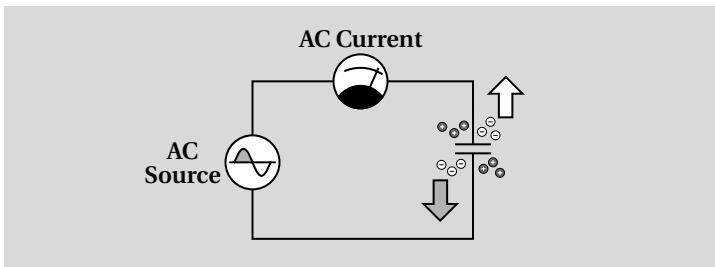

Figure 4-6. Capacitor connected to a source of AC, showing current flow during positive and negative AC cycles

(Figure 4-5). When connected to AC, charges move in and out of the capacitor as the polarity of the voltage alternates (Figure 4-6). The apparent result is that the capacitor blocks DC, but conducts AC.

Note that a perfect capacitor presents a resistance to the flow of AC that decreases with frequency. This resistance is called capacitive reactance or “ $X_C$ ” and can be calculated as:

$$X_C = 1 / (2 \times \pi \times F \times C)$$

where: F = the frequency

C = the capacitance in farads

As an example, the reactance of a 0.047 $\mu$ F capacitor at 10kHz would be calculated as:

$$X_C = 1 / (2 \times \pi \times F \times C)$$

$$X_C = 1 / (2 \times 3.14159 \times 10 \times 10^3 \times 0.047 \times 10^{-6})$$

$$X_C = 1 / 2.953 \times 10^{-3}$$

$$X_C = 338.63\Omega$$

Qualitatively, the equation reveals that at DC, capacitive reactance ( $X_C$ ) is infinite, while at very high frequencies,  $X_C$  approaches zero. This property makes capacitors useful for selectively passing high frequencies while blocking DC; a common application is bypassing an A/D input in order to filter noise from a signal. Capacitors can also be used in rudimentary anti-aliasing filters, although the roll-off of a capacitor is only 6dB per octave.

Another capacitor application that may be useful in data acquisition is based on the fact that a resistor in series with a capacitor produces a circuit that charges at a fixed time constant. The circuit in **Figure 4-7** exhibits an "RC Time Constant," which is the time needed for the voltage across the capacitor to rise to 63% of the applied voltage. The RC time constant for the circuit in **Figure 4-7** can be calculated as:

$$T = RC$$

$$T = 470000 \times 10 \times 10^{-6}$$

$$T = 4700000 \times 10^{-6}$$

$$T = 4.7 \text{ seconds}$$

After five RC time constants (5RC) have elapsed, the voltage on the capacitor will have risen to more than 99% of the power supply voltage. Conversely, a fully charged capacitor will take 1RC to discharge to 37%

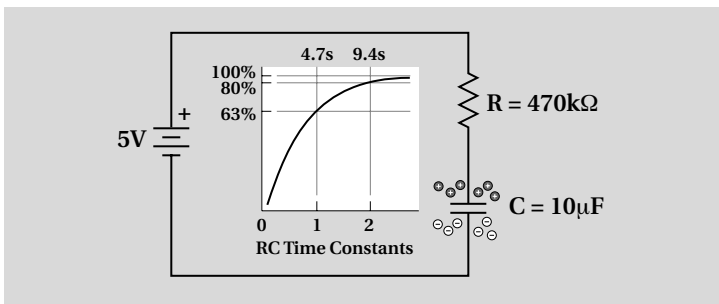

Figure 4-7. RC time constant

of its initial voltage, and  $5RC$  to discharge to less than 1% of its fully charged voltage.

The characteristics of capacitors make them useful in a number of areas in test and measurement. Their ability to pass higher frequency signals permits capacitors to be used as simple high frequency noise filters, particularly where the signal of interest is a DC voltage. Similarly, a knowledge of time constants and capacitor settling behavior is important in designing test and measurement systems where circuit capacitance is relatively high and signals change rapidly.

### 4.2.3 Inductors

The inductor is the third passive component. The principle behind the inductor is that if a magnetic field moves past a conductor, a current will be induced in the conductor. Conversely, when an electric current flows through a conductor, a magnetic field is generated around the conductor. If the conductor (wire) is wound in the form of a coil, both effects become more pronounced and form the basis of the electromagnets used in motors, generators, transformers, and related devices. However, even a single loop can increase the inductive effect. Understanding this principle can be of value in minimizing some types of noise pickup in data acquisition setups.

A closer analysis of inductors shows that current flow sets up a magnetic field in the coil, which causes the inductor to generate a *back voltage* (or *back EMF*) equal to the forward voltage. The faster the current changes, the greater the back EMF will be. An important aspect of back EMF is that when the source current is instantaneously disconnected from an inductor, the resulting magnetic collapse can generate a substantial voltage spike, which induces noise in surrounding circuits. This is why a diode is usually connected across a relay coil; the diode suppresses the back EMF that results when the coil is de-energized.

The unit of inductance is the henry (H), with typical inductor values in circuits on the order of millihenries or microhenries.

Like capacitors, inductors are constructed using a variety of materials and techniques that affect inductance. An ideal inductor would be a lossless coil exhibiting only inductive effects. However, a real-world inductor behaves more as a pure inductance in series with a resistance (**Figure 4-8**). This resistance is a result of the conductive properties of the wire winding and can vary with gauge, length, and composition of the wire. This resistance is important because it is a potential source of energy loss in the inductor.

The core of an inductor is also extremely important in establishing inductive properties. Inductor cores are fashioned from a variety of metallic materials in different shapes and dimensions, but torroids and cylindrical bars are the most common. Common core materials

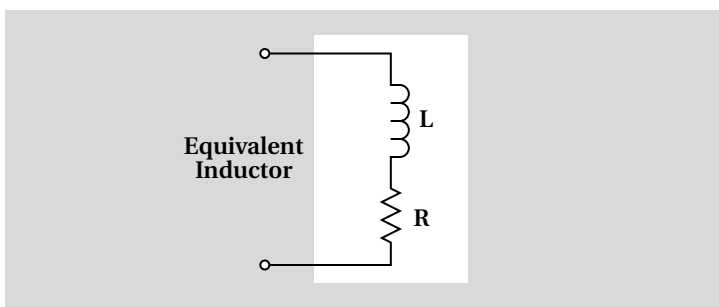

**Figure 4-8. Equivalent Inductor**

include iron and ferrite. However, the core can be omitted, resulting in an air core inductor. Small-value inductors can also be etched flat on printed circuit substrates.

The resistance of an inductor is frequency dependent. However, inductive reactance mirrors capacitive reactance in that it is 0 at DC, then increases with frequency. Inductive reactance ( $X_L$ ) can be calculated as:

$$X_L = 2 \times \pi \times F \times L$$

where: F = the frequency

L = the inductance in henries

As an example, the reactance of a 0.5 millihenry inductor at 3kHz would be calculated as:

$$X_L = 2 \times \pi \times F \times C$$

$$X_L = 2 \times 3.14159 \times 3 \times 10^3 \times 0.5 \times 10^{-3}$$

$$X_L = 9.42\Omega$$

Their coiled construction means that inductors tend to be more expensive than resistors and capacitors and are available in fewer values. Therefore, circuits are usually designed to achieve the desired performance using resistors, capacitors, and other components where possible.

### 4.3 Op Amp Theory

An active electronic device used extensively in solid-state electronic circuits is the operational amplifier or “op amp.” Op amps get their name from their original application, in which they were used to perform mathematical operations in analog computers. Today, op amps are used as general analog building blocks in a wide variety of circuits.

Unlike digital electronics, which have two valid output states (e.g., high or low, on or off), op amps are linear circuits where the output



represents a mathematical function applied to the input signal. The most common application of op amps is simple, linear amplification, where the op amp's output voltage is a multiple of the input voltage. However, integrators, differentiators, logarithmic amplifiers, and other functions can be constructed using op amps. Many uses exist for op amp circuits in data acquisition; it is often faster and less expensive to build these circuits rather than buy them.

The goals of this section are to summarize op amp theory and to highlight information that relates directly to these data acquisition applications. Many texts have been written on the topic of op amps and semiconductor manufacturers offer a variety of data books and application guides. These resources can supply detailed specifications and design information for a wide range of circuits.

#### 4.3.1 Types

Op amps are transistor circuits fabricated using a variety of semiconductor processes, including bipolar, JFET, CMOS, and mixed processes. Some operating parameters associated with op amps relate directly to the fabrication process, such as input impedance, power consumption, noise, drive capability, and bandwidth. These factors need to be considered when selecting components to ensure the desired result. For example, it is sometimes necessary to work with sensors with a low output level or high output impedance. In both cases, an op amp can be used to build a simple buffer amplifier to condition the signal. This application would best be served with an op amp with a very high input impedance, so one with FET inputs would be a good choice.

#### 4.3.2 Power Supply

The power requirement for most op amps, especially older components, is a symmetrical, positive and negative supply in the range of  $\pm 3$  to  $\pm 30$ VDC. Power supplies in AC-powered equipment containing op amps typically provide  $\pm 12$  to  $\pm 18$ VDC for op amp circuits. More recent trends in op amp design have been toward low power, application-specific devices that operate at lower voltages and currents, frequently  $\pm 5$ VDC or less.

As a class of devices, op amps require a relatively low operating current. However, current requirements vary sufficiently to make some families suitable for battery-powered circuits, while others are best used in AC-powered equipment. Again, consult specific op amp manufacturers' data sheets when contemplating an op amp project. Low power consumption is usually accomplished at the expense of other performance criteria.

#### 4.3.3 Input and Output Impedance

The input impedance of an ideal op amp is infinite, which would result in the op amp's inputs ( $V_+$  and  $V_-$ ) absorbing zero current. In reality,

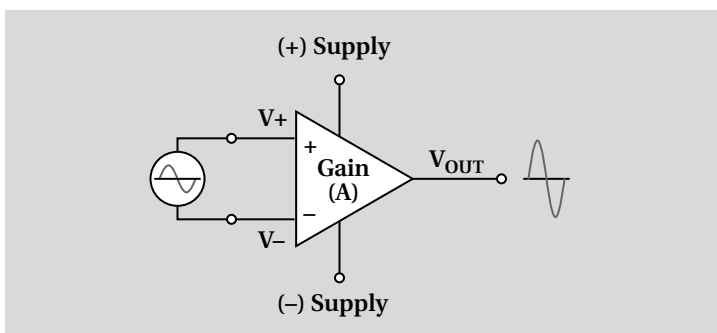

Figure 4-9. Op amp

while the input impedance of an op amp is not infinite, it is still very high. This characteristic makes op amp circuits useful for buffer and amplifier applications involving signals with a high source impedance. Actual input impedance depends on both the op amp's characteristics and the components used to construct the circuit. The highest input impedance is provided by op amps fabricated with MOSFET input transistors.

#### 4.3.4 Gain

The schematic symbol and simplified model of an op amp are shown in **Figure 4-9**. An op amp is a “differential” amplifier and will amplify the difference between the voltages applied to the inverting ( $V_-$ ) and a non-inverting ( $V_+$ ) inputs. The equation describing an op amp's function is:

$$V_{OUT} = ((V_+) - (V_-)) \times A$$

where  $V_+$  and  $V_-$  are input voltages,  $V_{OUT}$  is the output voltage, and  $A$  is the gain.

Note that the maximum output voltage from an op amp circuit depends on the supply voltage. A calculated output is valid only if the power supply voltages exceed the voltage by one to two volts. This is why most data acquisition boards can tolerate input voltages of only up to approximately  $\pm 10\text{VDC}$ . The boards are powered through an expansion slot from the computer's  $\pm 12\text{VDC}$  supply.

#### 4.3.5 Feedback

Op amps possess extremely high open loop gain (up to 100,000 or more), which is usually reduced with other components to a level suitable to the application. These components comprise the negative feedback loop of an op amp circuit, and are illustrated by  $R_1$  and  $R_2$  in **Figures 4-10** and **4-11**. Negative feedback is the mechanism by which op amp closed loop gain can be adjusted and a circuit made stable.

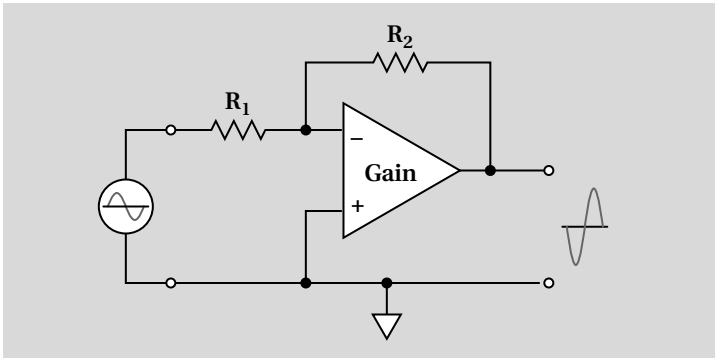

Figure 4-10. Inverting amplifier

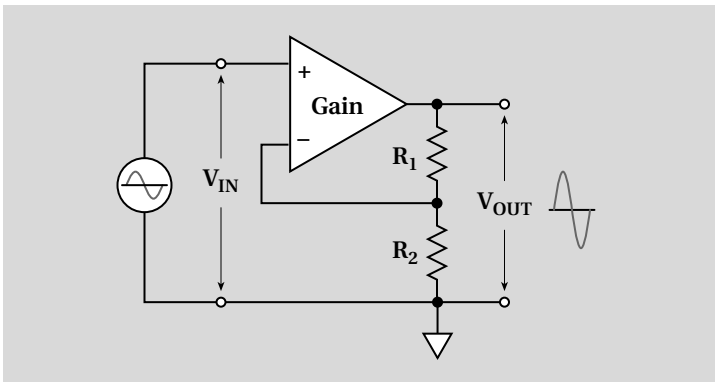

Figure 4-11. Non-inverting amplifier

A central operating principle of negative feedback is that an op amp will attempt to keep the voltage equal at both its inputs. This principle applies to inverting as well as non-inverting circuit configurations. In its simplest form, negative feedback uses a resistive divider between the output and inverting input of the op amp to send a portion of the output voltage back to the input. The op amp adjusts its output voltage as needed to maintain  $V_-$  equal to  $V_+$ . However, diodes and capacitors are frequently used in the feedback loop to configure integrators, differentiators, logarithmic amplifiers, and other types of non-linear circuits, or to adjust the response of linear circuits.

#### 4.3.6 Inverting vs. Non-Inverting Operation

An op amp can be configured to operate as an inverting or non-inverting voltage amplifier. In the inverting mode (**Figure 4-10**), a signal is

connected to the inverting (–) input, while the non-inverting input (+) is held at ground potential or some other reference voltage. The feedback loop acts to maintain both inputs at the same voltage (0V or a *virtual ground* in **Figure 4-10**). The input impedance of the inverting amplifier therefore equals  $R_1$ , and circuit's gain (A) can be calculated as  $R_2/R_1$ . The output voltage  $V_{OUT}$  for any given input  $V_{IN}$  equals  $V_{IN} \times R_2/R_1$ . The phase of the input signal will be shifted  $180^\circ$  at the output.

In non-inverting mode (**Figure 4-11**), no phase shifting occurs. Gain (A) can be calculated as  $1 + R_1/R_2$ , and the output voltage  $V_{OUT}$  calculated as  $V_{IN} \times (1 + R_1/R_2)$ . In this circuit, the input impedance at the (+) input equals that of the op amp, although a resistor or other component may be connected between the (+) input and other circuit points in some circuits, affecting input impedance. The circuit in **Figure 4-11** can be further simplified by removing  $R_2$  and making  $R_1$  equal to  $0\Omega$ . In this case, the circuit becomes a high input impedance voltage follower where the output voltage equals the input voltage (a gain of  $\times 1$ ).

#### 4.3.7 Normal Mode and Common Mode Voltages

Two terms that appear frequently in discussions of analog inputs are *normal mode voltage* and *common mode voltage*. An understanding of these terms is important in selecting and making the best possible use of data acquisition equipment, particularly in minimizing the effects of noise.

One definition of normal mode voltage ( $V_{NM}$  in **Figure 4-12**) is an error voltage that appears across the inputs of an amplifier, thereby adding to the input. Normal mode specifications are usually given at frequencies or frequency ranges where sources of noise are most common, such as 50Hz or 60Hz. The measure of an amplifier's ability to reject such noise while passing DC and low frequency signals is *Normal Mode Rejection Ratio* (NMRR), which is expressed by the equation:

NMRR (in dB) =  $20 \log [\text{peak NM noise}/\text{peak measurement deviation}]$

Qualitatively, the ideal amplifier would be completely unaffected by normal mode noise, making the peak measurement deviation 0, and the resulting ratio infinitely large. A more typical value for NMRR is 80dB. Each 20dB of NMRR reduces normal mode voltage by a factor of 10. Thus, an 80dB ratio will reduce a normal mode voltage by a factor of 10,000.

A practical example of normal mode voltage is noise pickup resulting from insufficient shielding, improper cable routing, etc. The effects of normal mode voltage are sometimes easy to discern, and can be eliminated through filtering, averaging, or post-processing of the signal. However, it is usually best to treat the problem through careful hardware layout. In particular, if a signal has components of interest in the same frequency range as the noise, it's critical to eliminate noise at

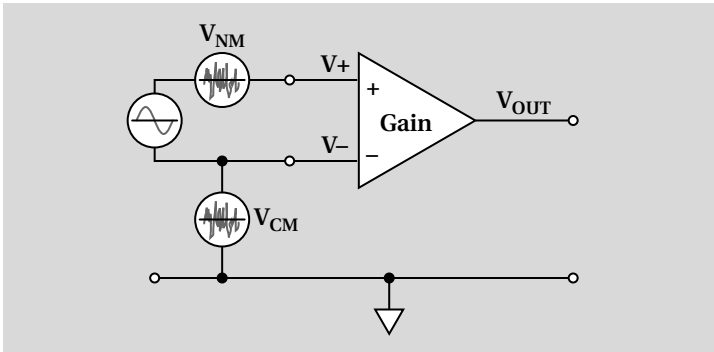

Figure 4-12. Normal Mode vs. Common Mode Voltages

its source, because it cannot be filtered out of the final data without affecting the data as well.

In contrast to normal mode voltage, *common mode voltage* ( $V_{CM}$  in **Figure 4-12**) appears between an amplifier's inputs and ground. Both inputs see the same common mode voltage in addition to the voltage differences attributable to the signal. As mentioned previously, an op amp amplifies the difference in voltage appearing at its (+) and (-) inputs, and will naturally reject a signal appearing at both inputs. The degree of this rejection is called *Common Mode Rejection Ratio* (CMRR). A typical value for CMRR is 120dB, meaning that a voltage appearing on both sides of a differential input will be reduced by a factor of one million.

In data acquisition, the effects of common mode voltage are sometimes noted as noisy measurements or inexplicable measurement errors. One situation where common mode voltage can present a problem occurs when individual circuit common points in a test setup are tied to ground at different locations. If each ground point is not a true, low impedance path to ground, a voltage gradient can exist across the grounds and current will flow (see **Figure 4-13**). This phenomenon is known as a *ground loop*. A ground loop may be produced when each end of the shield of a long cable is connected to separate chassis grounds. The voltage above true ground at one end of the shield can be higher than the other, "floating" one ground above the other, which results in current flow through the ground system. As a result, the acquired data will have an offset because it was not referenced to ground. The solution is to ground the shield at only one end.

A second example of a problem related to common mode voltage is where a sensor is allowed to "float," without a bias current return to ground. For instance, if a thermocouple is connected to an A/D input, the circuit may stop working after a few minutes. What has happened

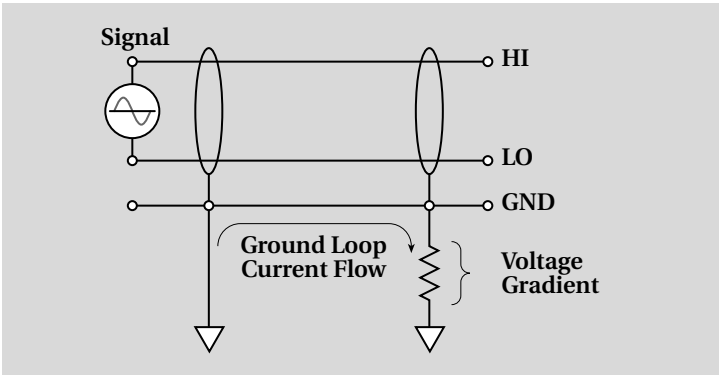

Figure 4-13. Ground loop

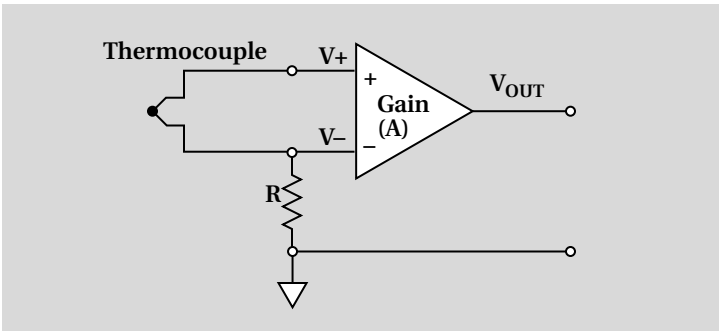

Figure 4-14. Thermocouple A/D input with ground return resistor (R)

is that the inputs gradually “charge” from the applied signal, increasing the common mode voltage on the inputs until they are too close to the power supply rails for the op amp to function. The solution is to install a resistor (R) between input high or input low and ground (**Figure 4-14**). A typical value for this resistor is one mega-ohm or more. This situation highlights the fact that the possibility of common mode voltage must be considered when a signal is connected to a data acquisition A/D input, and the total voltage at an input kept within  $\pm 10V$  relative to power supply ground.

#### 4.3.8 Single-Ended vs. Differential, Bipolar vs. Unipolar

The terms *single-ended* and *differential* are usually used to describe an amplifier (or op amp) input. A single-ended signal is one referenced to 0V. The signal can be carried by a pair of conductors, but one of the conductors is, by definition, tied to ground (0V). A differential signal requires a minimum of two conductors for transmission, but neither is

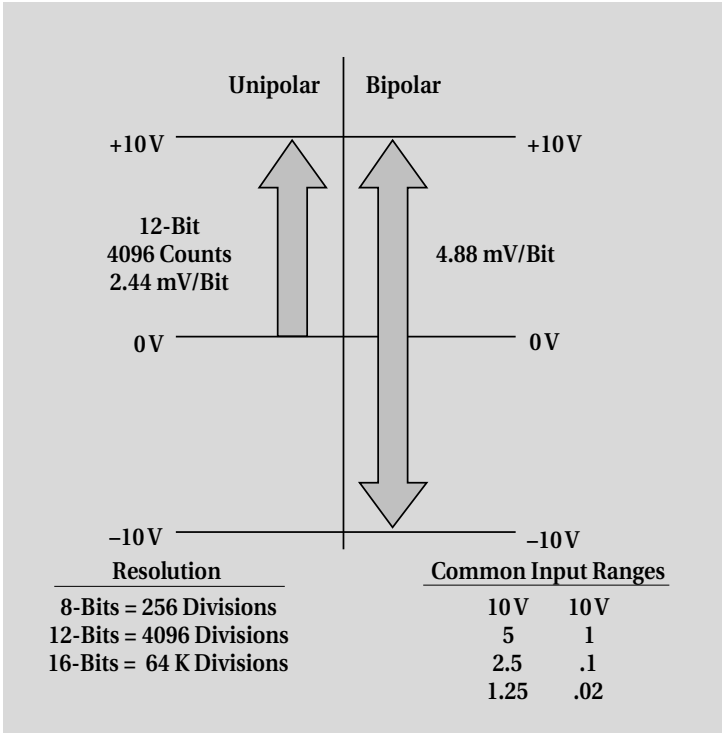

Figure 4-15. Bipolar and unipolar input ranges

necessarily tied to ground. In the case of a differential input, the measurement instrument responds to the difference in voltage between “signal high” and “signal low.” The differential method is often used to carry low-level signals, so the signal-carrying cable can actually consist of two signal leads plus a ground shield.

The terms *bipolar* and *unipolar* are normally used to describe whether a signal remains positive with respect to ground or whether it can also assume a negative level. These terms can apply to inputs as well as outputs. A bipolar signal can be positive or negative with respect to ground, while a unipolar signal generally goes no lower than 0V. The main benefit of using a unipolar range for digitized analog input or output is to enhance resolution. The available number of A/D or D/A bits remains the same, but is divided between only half the total voltage range of a bipolar configuration. Therefore, each bit provides twice the resolution. **Figure 4-15** shows the resolution on a 12-bit A/D in unipolar and bipolar configurations.

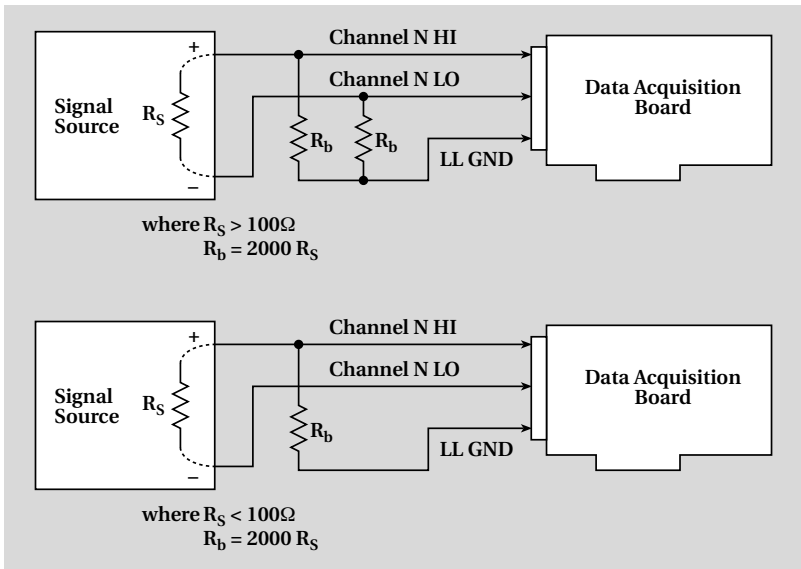

Figure 4-16. Differential input configurations

#### 4.3.9 Single-Ended vs. Differential Inputs for Signal Measurement

A differential input will usually offer better noise immunity than a single-ended input. This is especially important in systems that take data from a number of different sensors or are located a long distance from the sensors. **Figure 4-16** shows two connection schemes for wiring a signal source to a channel of a data acquisition board configured for differential input mode. The two circuits of the diagram require the addition of resistors to provide a bias current return. The value of the bias return resistors ( $R_b$ ) can be determined from the value of the source resistance ( $R_s$ ) by using the following relationships:

- When  $R_s$  is greater than  $100\Omega$ , use the connections in the upper circuit. The resistance of each of the two bias return resistors must equal  $2000 \times R_s$ .
- When  $R_s$  is less than  $100\Omega$ , use the connections in the lower circuit. The resistance of the bias return resistor must be greater than  $2000 \times R_s$ .

## 4.4 Filters

Some data acquisition applications can benefit from the use of filters to condition a signal. There are many types of filter designs, which can broadly be divided into passive and active types. Passive filters are relatively simple circuits constructed with resistors, capacitors, and



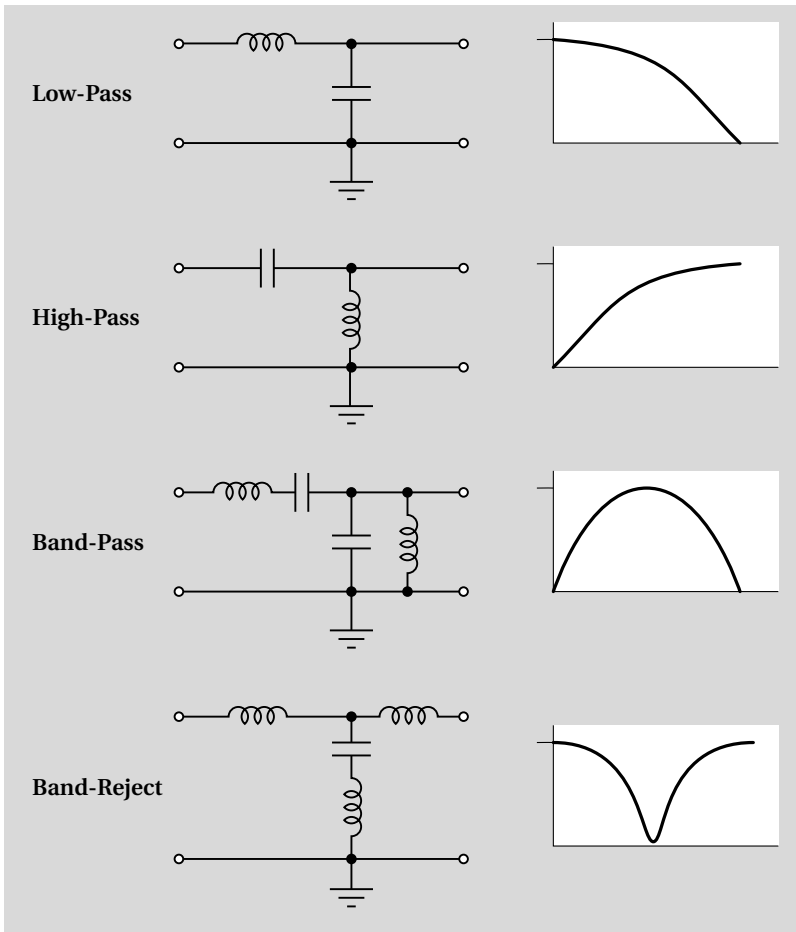

Figure 4-17. Passive L-C filter designs

inductors, but are generally less effective than active types. Active filters can provide more aggressive filtering action than passive filters. However, active filters are more complex in design, and also require a source of operating power. Bessel, Butterworth, Chebyshev, and Cauer (elliptical) filters are common active filter designs that use a combination of op amps and passive components.

The *response curve* or *cut-off* of a filter describes how well the filter blocks or passes a band of frequencies. Response is usually expressed as decibels (dB) of amplitude change per frequency span. Typically, the frequency span is specified per octave (amplitude change between fre-

quency  $f$  and  $2 \times f$ ) or per decade (amplitude change between frequency  $f$  and  $10 \times f$ ).

Passive filters are useful for a maximum of about 18dB per octave; beyond this point, a passive filter can affect the signal of interest adversely. Passive filters always impose some insertion loss, which becomes more severe as elements are added to tighten the response curve. **Figure 4-17** illustrates basic circuits for 12dB per octave high-pass, low-pass, band-pass, and band-reject (or notch) filters.

Active filter designs are suitable for response curves up to 80dB per octave. However, active filters can exhibit ringing, phase delay, ripple, distortion, loss, or less-than-perfect cut-off characteristics, depending on design and sharpness of response. Therefore, it's important to choose the type and design parameters for active filters carefully to optimize performance and avoid problems. The design of active filters is most easily accomplished with software programs, which are available on the Internet or from commercial sources. Active filters can also be purchased to pass or block specific frequencies.

## 4.5 Digital I/O

Many data acquisition processes involve digital signals that are either on or off, high or low, etc. This is in contrast to analog signals where the signal voltage can range anywhere between an upper and lower voltage limit. One gauge of the quality of analog I/O is bits of resolution, with 12- and 16-bit A/D and D/A being common in data acquisition. Conversely, a digital signal is a 1-bit phenomenon; the signal is ultimately represented as a single "1" or a "0." While this sounds simple in concept, there are many factors that can complicate digital measurement and control.

Digital signals are usually generated or read by digital gates, which can have a single output and single or multiple inputs. Normally, an integrated circuit package will contain two to six gates, depending on the number of pins the package can support. There are a variety of Boolean logic functions for gates with multiple inputs—AND, NAND, OR, and NOR being the most common (see **Figure 4-18**). For more information on this topic, consult a text such as the *TTL Cookbook* or a manufacturer's data book.

Note in **Figure 4-18** that the various types of digital gates can be subdivided into non-inverting and inverting types. A non-inverting gate produces a logic 1 output when the logical input function of the gate is satisfied. For example, an AND gate requires all inputs to be at logic 1 for an output of logic 1. The inverted form, the NAND gate, produces a logic 0 output when all inputs are at logic 1. Also note that versions of the inverting and non-inverting gates exist where there is only one input. The inverting version is simply called an *inverter*, while the non-inverting version is called a *buffer*.

"AND" GATE	"NAND" GATE	"OR" GATE	"NOR" GATE
All Inputs = "1" For Output = "1"	All Inputs = "1" For Output = "0"	Any Input = "1" For Output = "1"	Any Input = "1" For Output = "0"
Any Input = "0" For Output = "0"	Any Input = "0" For Output = "1"	All Inputs = "0" For Output = "0"	All Inputs = "0" For Output = "1"

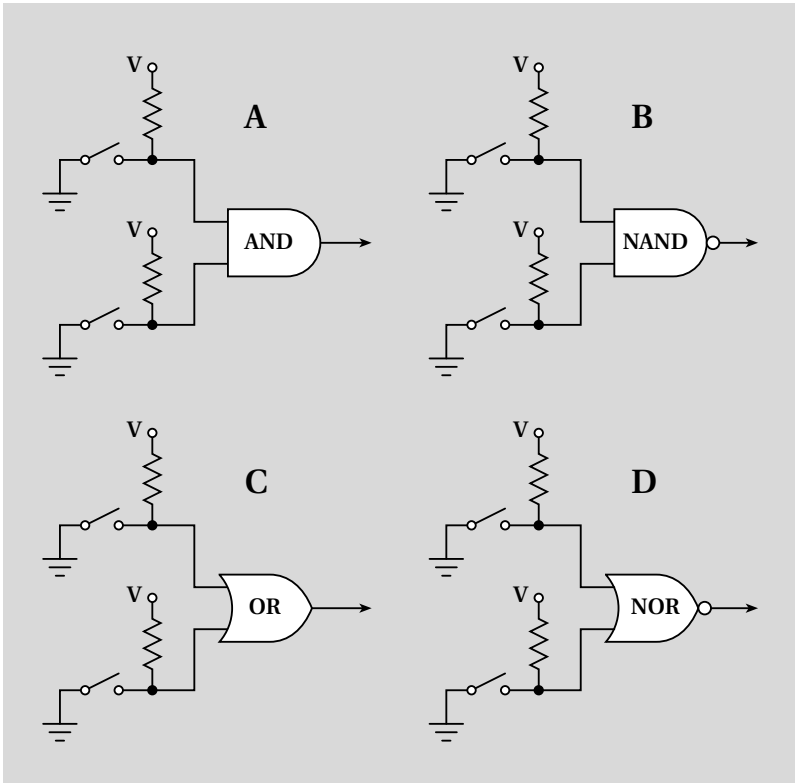

Figure 4-18. Digital gates

The remainder of this discussion on gates concentrates on how to control individual gate inputs and use outputs.

#### 4.5.1 Digital Logic Types and Logic Levels

The type of semiconductor process used to fabricate a digital gate determines the operating parameters for the device. The most important parameters include:

- Voltage corresponding to logic 1 and logic 0.
- Compatibility with other families of analog or digital circuitry.

- Voltage and power needed to operate the device.
- Speed capability (generally important only when dealing with rapidly changing signals).

The usual method for activating a digital input is to connect the input to ground or 0V, which causes current to flow from the input to ground. This process is commonly referred to as “sinking current,” and can be accomplished using a mechanical switch, a transistor wired as a switch, the output of another digital gate, or a sensor that includes one of these devices (**Figure 4-18** shows mechanical switches). Note that a typical digital output can usually sink enough current to control up to 10 or more inputs of the same logic family. The term for this capability is fan-out. Exceeding the recommended fan-out can result in unreliable operation of a digital circuit. Similarly, mixing different logic families can result in improper operation.

#### 4.5.2 TTL Logic

One of the first and most common semiconductor processes used to fabricate digital gates is Transistor-Transistor Logic (TTL). TTL gates are constructed with bipolar transistors, which provide relatively high current source and sink capability and high speed, but also consume more operating power than some newer types of devices. The standard power supply voltage for TTL logic is +5VDC.

The voltages and current levels corresponding to logic 1 and logic 0 for TTL are:

- Logic “0” = 0.0–0.8 volts. For conventional TTL, control signal must be capable of sinking at least 1.6mA from a digital input. Newer implementations of TTL-type logic have substantially reduced this current requirement to as little as 10 $\mu$ A.
- Logic “1” = 2.0–5.0 volts. The actual output voltage of TTL devices is usually between 3.5V and 5V. Typical output source current is 0.4mA (400 $\mu$ A). New types of TTL logic may have lower source current capability.

For TTL, note that the input range is neither symmetrical nor continuous. There is a gap in the values between 0.8 and 2.0 volts in which the signal is ambiguous, defined neither as a “1” nor a “0.” In some situations, such as when trying to read an analog or slow-moving signal, this can cause problems. However, several options are available for dealing with ambiguous or slow-moving digital input signals. These are discussed elsewhere in this book.

Because of its design, a TTL output is effective at sinking current to ground to create a logic 0. However, sufficient variation exists in the design of TTL output stages that a logic 1 output voltage must be defined more broadly. Some TTL outputs swing to 3.5V or higher and

**Table 4-3. Typical TTL input and output specifications**

Input High Voltage:	2.0V minimum, 5.0V maximum
Input Low Voltage:	0.0V minimum, 0.8V maximum
Input High Current:	0.02mA
Input Low Current:	-0.4mA
Output High Voltage:	2.7V minimum
Output Low Voltage:	0.5V maximum
Output High Current:	-0.4mA
Output Low Current:	8.0mA

can source a small amount of current, while others (open collector types) “float” when set to logic 1, and have no real drive capability.

Although TTL logic was an early development in digital integrated circuitry, it remains the *de facto* standard for digital I/O for several reasons. TTL can easily drive high load currents and is much less susceptible to damage from static electricity. Devices implemented with other types of circuitry often use TTL’s logic levels for backward compatibility with TTL. Further, TTL has spun off related device families where various operating parameters such as power consumption and speed are optimized for certain types of tasks. These optimizations permit engineers to design in terms of TTL conventions. Low Power Schottky TTL (LS-TTL) is one such family, which is often used in manufacturing digital I/O boards. As the name implies, LS-TTL requires less power to operate than standard TTL.

### 4.5.3 CMOS Logic

CMOS (Complementary Metal Oxide Semiconductor) technology was developed after TTL as a low power alternative to existing bipolar transistor technology. CMOS technology is used in linear as well as digital devices, and offers such advantages as operation over a wide range of supply voltages and extremely low current consumption. Therefore, many products that use CMOS devices can be operated from batteries or from much smaller power supplies than those required for TTL.

The disadvantages of CMOS logic relative to digital I/O applications include sensitivity to static damage and incompatibility with TTL signal levels. The threshold voltage that differentiates logic 1 from logic 0 with a CMOS input is roughly half the power supply voltage. The transition from logic 1 to logic 0 does not contain any appreciable dead zone, as does TTL. The current sink capability of a CMOS gate is also relatively low. However, buffer devices are available that can drive TTL from CMOS.

---

SECTION 5

**Basic Analog  
and Digital I/O**

---

## 5.1 A/D Conversion

Voltage measurement during data acquisition relies on a process known as analog-to-digital conversion (often abbreviated as *A/D* or *A-to-D*). An analog input board contains an A/D converter and support circuitry (**Figure 5-1**), which conditions and digitizes the incoming voltage. The following list summarizes the individual circuit stages and operation of a typical complete A/D circuit. Specialized analog input boards may depart from this description, with multiple A/D converters, large FIFO buffers, circular buffers, triggering, or other features.

- Signal conditioning (optional)
  - Sensor excitation
  - Filtering
  - Input protection
- Multiplexer (selects a channel on multi-input A/D boards)
- Programmable instrumentation amplifier (applies gain)
- A/D converter (digitizes the signal)
- FIFO buffer (temporarily stores measurement data)
- Control circuitry (retrieves data from FIFO buffer)

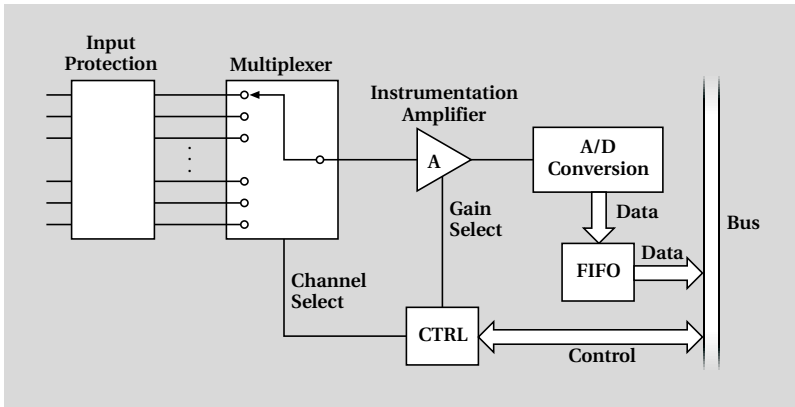

Figure 5-1. Typical A/D converter and associated circuitry

### 5.1.1 A/D Resolution and Speed

Three of the most important specifications involved in choosing an analog input board are A/D converter resolution, accuracy, and speed. These specifications and other A/D characteristics are interrelated, because higher performance in one area may come at the expense of performance in other areas. For example, high speed and high resolution are usually mutually exclusive to some degree, and achieving both

in a single product usually results in an elevated price. However, the premium for higher performance is not as high as it once was.

### 5.1.2 Resolution

The function of an A/D converter is to generate a series of unique digital output states corresponding to a specific range of analog input voltages. The ideal A/D converter would accept an infinite range of input voltages and digitize the range into an infinite number of output states. This is, of course, technically impossible. Fortunately, the factors that limit real-world A/D resolution are easy to identify and understand.

As a general rule, the input voltage range of any A/D input is limited by the voltage used to power the circuit. A plug-in A/D board for a computer receives operating power (a nominal  $\pm 12\text{VDC}$ ) from the computer expansion slot in which it resides. The analog input board requires 1–2V of headroom, limiting the actual input range to about  $\pm 10\text{VDC}$ . This is, in fact, a very common input voltage limit for analog input boards. Gain stages in front of the A/D converter can increase sensitivity and reduce the permissible input to  $\pm 5\text{VDC}$ ,  $\pm 2.5\text{VDC}$ ,  $\pm 1.25\text{VDC}$ , or some other fraction of  $\pm 10\text{VDC}$ , but the maximum signal voltage farther into the A/D circuitry will not exceed  $\pm 10\text{V}$ . Stand-alone instruments can be powered by internal supplies that aren't affected by this limitation, so they may offer a broader input dynamic range.

Standard resolutions of plug-in A/D boards are 8, 10, 12, and 16 bits, while stand-alone instruments can offer 18–24 bits of resolution or more. This represents the number of output bits the A/D converter has available to digitize an analog input voltage. The voltage resolution per bit ( $V_{\text{RES}}$ ) can be calculated as:

$$V_{\text{RES}} = \frac{V_{\text{INPUT}}}{2^{(\text{No. of bits})}}$$

For example, an 8-bit converter can output 0000 0000 to 1111 1111 (binary). This corresponds to  $2^8$  or 256 discrete steps. An input range of  $\pm 10\text{V}$  divided by 256 steps equals  $20\text{V}/256$  or  $78.125\text{mV}$  per step. A 16-bit converter would have a resolution of  $20\text{V}/2^{16}$  or  $1.22\text{mV}$  per step for the same  $\pm 10\text{V}$  input.

Most A/D boards can also be configured for unipolar operation, where the input range extends from 0 to  $+10\text{VDC}$ , 0 to  $+5\text{VDC}$ , etc. The method for calculating the resolution of bipolar measurements is also applicable to unipolar ones. **Table 5-1** compares resolution and other A/D characteristics as a function of A/D converter bits.

This table highlights several facts concerning A/D converters. First, an A/D can not read a voltage equal to its maximum range (i.e.,  $10\text{V}$  on a  $10\text{V}$  range), even in unipolar mode. In the case of each converter range shown in **Table 5-1**, the maximum readable voltage is one bit less



**Table 5-1. Measurement resolution and maximum ranges for different A/D resolutions**

	Converter Bits (n)			
	8	10	12	16
<b>Output States (2<sup>n</sup>)</b>	256	1024	4096	65,536
<b>Resolution, 0–10V input</b>	39.06 mV	9.765 mV	2.441 mV	152.59 $\mu$ V
<b>Resolution, 0–5V input</b>	19.53 mV	4.883 mV	1.221 mV	76.29 $\mu$ V
<b>Resolution, <math>\pm</math>10V input</b>	78.12 mV	19.53 mV	4.883 mV	305.2 mV
<b>Resolution, <math>\pm</math>5V input</b>	39.06 mV	9.765 mV	2.441 mV	152.59 $\mu$ V
<b>Resolution, <math>\pm</math>2.5V input</b>	19.53 mV	4.883 mV	1.221 mV	76.29 $\mu$ V
<b>Resolution, <math>\pm</math>1.25V input</b>	9.76 mV	2.441 mV	610.35 $\mu$ V	38.15 $\mu$ V
<b>Max. input, 0–10V (res <math>\times</math> 2<sup>n</sup>–1)</b>	9.960 V	9.990 V	9.9976 V	9.99985 V

than the range. Second, an averaged reading at zero volts will equal zero only for a measurement made in bipolar mode; in unipolar modes, there are no negative readings to bring the average to zero. Typical reading jitter with a digital input is at least one A/D count, placing the average for a series of readings made in unipolar range somewhere between zero and a few A/D counts. These observations apply more to plug-in A/D data acquisition boards than to instruments.

Third, and perhaps less obvious, is that A/D offset errors can swamp gain errors, especially for lower resolution boards. For the sake of comparison, consider the maximum reading on a 0–10V scale for 8- and 16-bit A/D converters. For the 8-bit converter, one bit of uncertainty represents 39mV, which calculates as  $100 \times (0.039V/9.96V)$ , or 0.39%. At 16 bits, the error is 152 $\mu$ V, which corresponds to 0.0015%. In comparison, gain errors of 0.01% to 0.05% are common for analog input boards. This observation can apply to stand-alone instruments as well.

Total error figures for a specific measurement situation depend on the input voltage as well as the equipment and the environment. The key to specifying the correct resolution for an application is to match the resolution of the board to the resolution required of the measurement. In general, higher resolution A/D converters are more expensive than their lower resolution counterparts. Buying capability somewhat beyond current needs can provide insurance against obsolescence. On the other hand, purchasing more capability than will ever be required has no benefit. For example, if an application uses a pressure sensor accurate to  $\pm$ 1% (1 part in 100), a 16-bit A/D board will likely add needless expense to the system. Also note that, even if the application justifies the cost, a very high resolution A/D can still be a waste of money if the less significant A/D bits are swamped by noise in the measurement environment or from the sensor. Signal averaging can help the situa-

tion in this case. Furthermore, higher resolution A/D converters are usually slower than lower resolution versions.

### 5.1.3 Input Accuracy

Input accuracy is related to, but not equal to, input resolution. The accuracy of a data acquisition board depends on its whole analog front end, including the input multiplexer, the programmable gain amplifier, and the A/D converter.

Accuracy can be specified as absolute accuracy or relative accuracy. Absolute accuracy at a given A/D output code is the difference between the actual and the theoretical voltage required to produce that code. Relative accuracy is the deviation from the theoretical value after the full-scale range has been calibrated.

Input accuracy can be specified in a number of ways. Three of the more common specification methods, along with the formulas required to convert the specifications into voltage accuracies, are shown in **Table 5-2**. All calculations assume a 12-bit A/D converter and a 10V full-scale input.

*Table 5-2. Comparison of analog accuracy specification formats*

<b>SPEC: 0.024% of reading ±1 bit (Gain + Offset method)</b>
Measurement Accuracy = $10V \times \left( \frac{0.024}{100} + \frac{1}{2^{12}} \right) = 4.8mV$
<b>SPEC: ±2 bits (Total Bits of Deviation)</b>
Measurement Accuracy = $2 \times \frac{10V}{2^{12}} = 4.8mV$
<b>SPEC: 0.048% of FSR (Percentage of Full Scale Range)</b>
Measurement Accuracy = $10V \times \frac{0.048}{100} = 4.8mV$

Note that in the examples, the A/D accuracies are specified differently, but the results are identical.

### 5.1.4 Maximum A/D Speed

The maximum speed of an A/D converter relates to the number of digitizations that can be performed in a unit of time. Typically, the maximum sample rate is specified in samples/second (S/s), kilosamples/second (kS/s) or megasamples/second (MS/s), not in hertz (Hz).

Most multi-channel A/D products contain a single A/D converter and input multiplexer (**Figure 5-1**). The multiplexer acts as a switch that allows each of the input channels to be sampled independently. The maximum sample rate per channel is no faster than the maximum sample rate of the A/D converter divided by the number of channels

sampled. For example, an 8-channel analog input board might be capable of 100,000 samples per second. A single channel could be sampled at the full 100,000 S/s, two channels at 50,000 S/s each, and so on.

In many cases, the maximum sample rate is specified with all channels set to the same gain. If different gains are set for channels in a scan list, the overall sampling speed can suffer unless there is an onboard gain or gain/channel queue. A gain queue permits specifying a different gain for each channel. As the channel multiplexer is incremented, the associated channel gain is set. However, high gain settings may impose long settling times and slower A/D conversions, even where a gain queue is used.

### 5.1.5 A/D Techniques

The mainstream A/D conversion methods for data acquisition and measurement instruments include *successive approximation*, *integrating*, and *flash converters*. Each conversion method offers a different combination of performance and price that makes it suitable for a specific set of data acquisition applications. There are also several other varieties of A/D conversion, which may be used in more specialized data acquisition applications.

Normally, instrument and board manufacturers select an A/D technology appropriate for the primary goals of a product. The three most important characteristics of A/D product design are speed, resolution, and cost. Frequently, the user has to accept compromises in one area to obtain essential performance in another area. It is important to be aware of the limitations associated with different conversion methods. **Table 5-3** briefly describes some of the main characteristics and tradeoffs of mainstream A/D converter technologies.

*Table 5-3. A/D converter types popular for data acquisition*

Converter Type	Maximum Speed	Typical Resolution	Noise Immunity	Relative Cost
Successive Approximation	Medium (10kHz to 1MHz)	6–16 bits	Little	Low
Integrating	Slow (10Hz to 30Hz)	12–24 bits	Very Good	Low
Flash	Very Fast (1MHz to 500MHz)	4–8 bits	None	High
Sigma-Delta	Slow to Medium (Up to 1MHz or higher)	16 bits or more	High	Low

### 5.1.5.1 Successive Approximation A/D

Most general-purpose data acquisition boards use successive approximation converters. Successive approximation converters offer an optimal compromise between high speed, high resolution, and cost.

The operating principle of the successive approximation A/D converter is that the unknown voltage and the output of a digital-to-analog (D/A) converter are both fed to a comparator. The output of the D/A is adjusted until the inputs to the comparator are equal and the comparator “balances.” The binary output code of the D/A then represents the voltage of the unknown signal. The A/D simply tracks the input, so any noise on the signal of interest will also appear in the digital output.

### 5.1.5.2 Integrating A/D

The general operating principle of the integrating A/D converter is based on the charging and discharging of a capacitor by an unknown signal and a reference voltage. The capacitor is charged first by the unknown signal for a set time interval. Next, the capacitor is discharged back to zero at a fixed rate and the time needed to discharge the capacitor is measured. This time is a measure of the integrated input voltage and can be used to deduce the unknown voltage.

A benefit of the integrating A/D conversion process is that it can average out noise over time, which results in good noise rejection. The integration time can be selected to match the frequency of a known noise source, which allows the integrating A/D to be particularly effective against certain types of noise. Commonly, integration times that are multiples of 50Hz and 60Hz are used (sometimes referred to as *line cycle integration*) to minimize the effects of AC noise on the measurement.

Integrating A/D converters are more accurate and linear than successive approximation converters, so they are a good choice for low-level measurements. While integrating A/D converters are often used in DMMs and other stand-alone instruments, they are not as common in data acquisition boards.

### 5.1.5.3 Flash Conversion

Very high-speed analog input boards use flash converters to achieve acquisition rates of megasamples per second or even gigasamples per second. The heart of the flash converter is an array of voltage comparators that simultaneously sample the unknown voltage in parallel. Collectively, the comparator outputs represent a progressive series of bits, which are then encoded into a standard binary output.

The chief drawback of flash A/D converters is that the number of comparators increases exponentially with output resolution. For example, an 8-bit flash A/D requires  $2^8 - 1$  or 255 comparators, while a 16-bit flash A/D requires  $2^{16} - 1$  or 16,383 comparators. Therefore, the

cost of a flash converter escalates quickly for higher resolutions. For this reason, very high speed analog input boards most often provide low to medium A/D resolution.

Like the successive approximation converter, the flash A/D simply tracks the input, so any signal noise will also appear in the digital output. Further, because flash converters are intended for high speed signal capture, it can be difficult to filter high frequency noise from a signal without affecting the signal itself.

#### 5.1.5.4 Sigma-Delta Conversion

The Sigma-Delta (also called Delta-Sigma or *one-bit*) conversion method is based on theoretical technology that has existed for many years. It is only with the realization of high speed digital and analog circuitry that the hardware necessary to implement sigma-delta converters has been feasible.

Sigma-delta conversion uses an oversampling modulator (a voltage-to-frequency converter) and a digital filter to digitize an analog voltage. The modulator loop oversamples and processes the analog input at a rate much higher than the bandwidth of interest. The modulator's output provides information to the filter one bit at a time, at a very high rate, and in a format that the digital filter can process to extract higher resolution (such as 16 bits) at a lower rate.

With sigma-delta conversion, there is a tradeoff between speed and resolution. The hardware has to operate at a much higher (oversampled) rate than the signal bandwidth, which places greater demands on the digital circuitry. Thus, sigma-delta converters typically are used for high resolution, relatively low frequency applications. In return, this technique provides many advantages, such as good temperature stability, low cost, highly linear operation, and minimal requirements for post-A/D anti-aliasing filters.

#### 5.1.6 Aliasing and Anti-Aliasing Filters

An alias is a false signal component that appears in sampled data acquired at too low a sampling rate. Aliasing errors occur when a signal contains frequency components that are faster than one half the sampling frequency (the *Nyquist rate*). For example, if acquiring data from one channel at 100kS/s, the signal cannot contain any frequency components greater than 50kHz, or false, low frequency artifacts (aliasing) will appear when the data is used to reconstruct the waveform. If eight channels are sampled by the same A/D converter, the maximum sample rate for each channel is 12.5kS/s and the aliasing errors will be caused by any frequency component greater than 6.25kHz.

Aliasing errors are hard to detect and almost impossible to remove using software. The solution to aliasing is to use a high enough sampling rate or, if this is not possible, to use an anti-aliasing filter in front

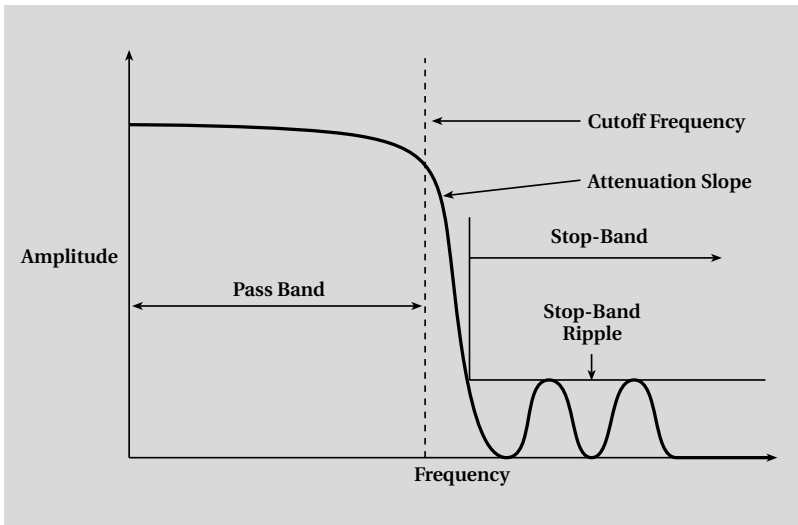

Figure 5-2. Response of an anti-aliasing filter

of the analog-to-digital converter to eliminate the high frequency components before they get into the data acquisition system. Among the more common types of anti-aliasing filters are Butterworth, Bessel, and Cauer, each of which has specific filter characteristics. **Figure 5-2** shows a typical anti-aliasing response curve. The pass band indicates the frequencies that pass through the filter unchanged. The stop band includes the frequencies that are attenuated by the filter. The filter type determines the slope of the attenuation curve and the amount of ripple in the stop band. Cauer filters have the sharpest cutoff; however, their transient response is not as good as that of the others. The Bessel filter has the slowest cutoff of the three types and also has the best transient response.

## 5.2 D/A Conversion

Digital-to-Analog (*D/A* or *D-to-A*) conversion is the process used to generate an analog output voltage, usually in response to digital data supplied by a computer or other control circuitry. To some degree, *D/A* conversion is the inverse of *A/D*.

A common *D/A* converter design couples a reference voltage with a resistor network and control logic to generate specific voltages in response to binary input data. As with *A/D* converters, multiplexers can be included in *D/A* designs to provide multiple output channels using one converter.

The output characteristics of D/A converters are also similar to those of A/Ds. Twelve- and 16-bit resolutions are common, as are typical full-scale ranges based on 0–10V,  $\pm 10V$ , 0–5V,  $\pm 5V$ , 0–2.5V,  $\pm 2.5V$ , etc.

One important characteristic of D/A converters is that they normally offer only a few milliamps of drive current. Therefore, applications that require higher currents need to incorporate an external circuit or programmable power supply to boost available current.

### 5.2.1 Four-Wire Remote Sensing

The ability to perform four-wire measurement techniques in conjunction with D/A conversion is a concept borrowed directly from bench-top instrumentation and is a relatively rare capability with PC-based analog output boards. Keithley's Series KPCI-3130 analog output boards provide this capability.

This technique uses a pair of sense leads that extend from the device under test, back to a high input impedance voltmeter stage on the D/A board. Theoretically, the current flowing in the sensing loop will be nil and will be unaffected by any voltage drop associated with the leads connecting the analog output to the DUT. The sensed voltage can be used to adjust the board's analog output level quickly and transparently, until precisely the desired voltage is present at the DUT, regardless of cable lengths and interconnection losses.

The ability to perform four-wire remote sense operations provides a significant advantage over standard analog output PC hardware. This feature becomes of critical importance when generating control signals over long distances. Significant voltage drops can occur as the result of cable resistance, device interconnections, and terminations; therefore, the programmed output value may not be the actual voltage delivered to the device under test (DUT) that is located at the end of the cable.

## 5.3 Interfacing Digital I/O to Applications

Communication between digital circuits depends on the ability of outputs and inputs to generate and interpret valid ON and OFF states. Several different digital logic standards exist, the most common being Transistor-Transistor Logic (TTL) and Complementary Metal Oxide Semiconductor (CMOS). TTL circuits appear to be more common, perhaps because they have been around longer than CMOS; their design rules are well understood and they are relatively immune to static damage. Each logic family has different specifications for voltage and current levels that define ON and OFF, as well as any ambiguous signal states that might exist between ON and OFF. The I/O specifications for a typical Low-Power Shottky (LS-TTL) compatible digital I/O board are shown in **Table 5-4**. LS-TTL is a more recent version of TTL logic, offering lower power consumption.

**Table 5-4. Typical TTL input and output specifications**

Supply Voltage:	5VDC
Input High Voltage:	2.0V minimum, 5.0V maximum
Input Low Voltage:	0.0V minimum, 0.8V maximum
Input High Current:	0.02mA
Input Low Current:	-0.4mA
Output High Voltage:	2.7V minimum
Output Low Voltage:	0.5V maximum
Output High Current:	-0.4mA
Output Low Current:	8.0mA

The specifications for commercially available digital I/O boards and sensors normally describe I/O capabilities sufficiently to allow matching inputs and outputs without concern for what sort of logic has been used in either.

Most Keithley digital I/O boards are intended to read or control TTL-level signals. Most feature protection against occasional transients, but are not intended to dissipate significant amounts of energy where the board is connected to voltages far outside the range of 0–5V. However, some digital I/O boards can read a much higher maximum input voltage than 5V. Always check equipment specifications for compatibility with the intended signals.

### 5.3.1 Interfacing with Mechanical Switches

Switch contacts can be interfaced to a digital input by adding a *pull-up resistor*, as shown in **Figure 5-3**. Some digital I/O boards and instruments provide a socket and header to facilitate user installation of pull-ups. The use of a pull-up resistor ensures that the digital input will receive a reliable TTL high input level when the switch is open. Generally, all unused digital inputs should be tied to the positive supply or ground. Unterminated digital inputs can be affected by noise and cause unreliable operation.

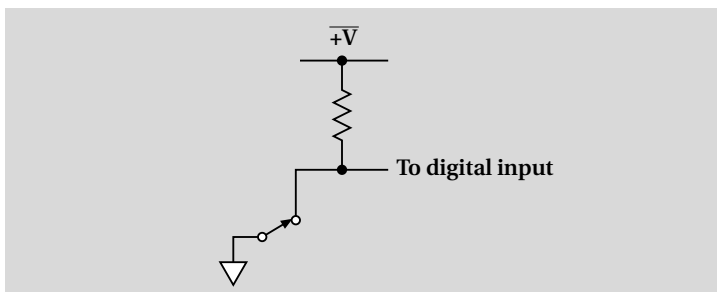

**Figure 5-3. Pull-up resistor**



### 5.3.2 Contact Debouncing

When a mechanical switch snaps shut, there is a short period—typically 1–5ms—when the contact surfaces bounce against each other. Some logic inputs, notably digital counters, read this contact bounce as a burst of pulses or ON/OFF signals (**Figure 5-4**). Solutions to contact bounce can be implemented in software or hardware, although debouncing in software is often preferred because it is less expensive. A common software technique involves performing multiple readings until the signal becomes stable. This may impose a slight delay in the control program. Hardware debouncing is relatively instantaneous and also more suitable where software is not used to read switch contacts. Hardware debouncing requires a flip-flop circuit for each digital input channel to provide a clean signal. **Figure 5-5** shows a common example.

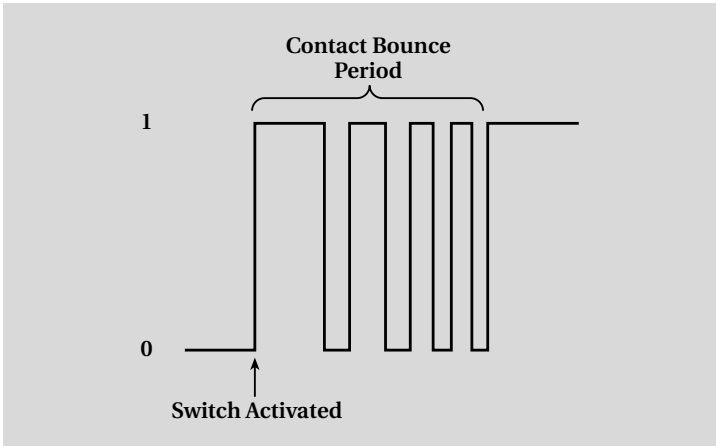

Figure 5-4. Contact bounce

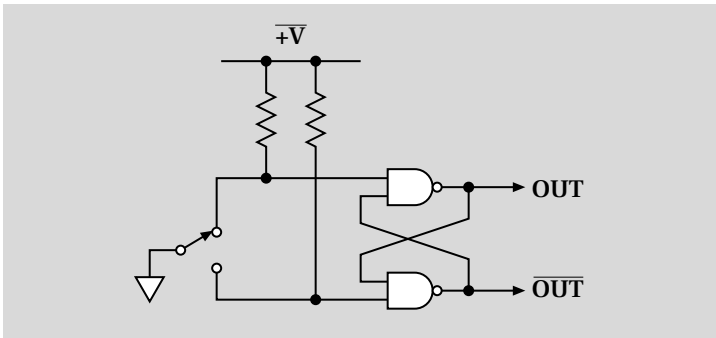

Figure 5-5. Hardware debounce circuit

### 5.3.3 Dry Switching

Ordinary relay contacts designed for relatively high currents (>100mA) have large surface areas made of arc-resistant materials. These materials can be unreliable for switching currents of a few milliamps or less, because the limited signal energy cannot break through the film that tends to build up on contact surfaces. Switches designed for *dry circuits* have softer crosspoint contacts that will work well with small voltages and currents. This is one case in which specifying a higher rating for the contact may actually be *less* reliable.

### 5.3.4 Slow Moving Signals

A TTL ordinary digital input is designed to read signal levels that satisfy the specifications describing ON and OFF (**Table 5-4**), but can provide unpredictable operation when connected to a slowly changing voltage. A slow moving signal might remain in the ambiguous 0.8V–2.0V range long enough to cause multiple triggerings, rather than a smooth transition from one logic level to the other (**Figure 5-6**).

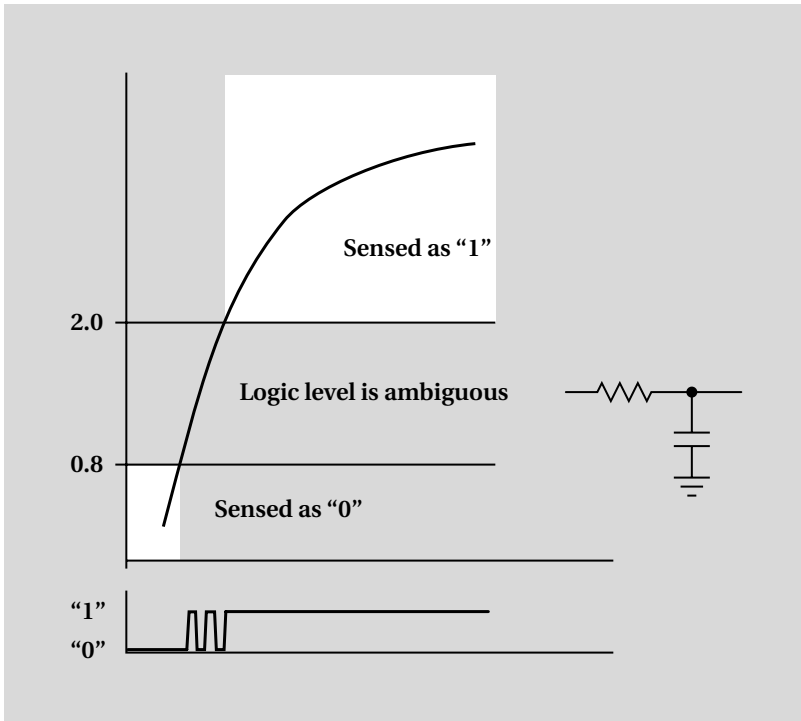

Figure 5-6. Slow moving digital signal can result in unreliable switching

There are several ways to deal with this situation:

- Correct the input signal so it changes more quickly.
- If it is necessary to detect a specific voltage level, read the signal using an analog comparator. If necessary, condition the comparator's output with a digital gate.
- If the exact switching level is not important, but clean switching from slow or noisy signals is required, use a digital input with hysteresis (a *Schmidt trigger*). Hysteresis establishes different voltages for logic 1 and for logic 0, depending on whether the signal is rising or falling. The result is a *snap action* when the input detects a logic 1, because the voltage needed to trigger a logic 0 is considerably lower.

Somewhat the same effect can be achieved in software by ignoring state changes that occur too soon after the previous change. The effectiveness of this kind of pulse-width discrimination depends on the characteristics of the input signal and on how costly the additional programming required will be when compared with a hardware solution.

### 5.3.5 Dealing with TTL-Incompatible Signal Levels

TTL switching levels have become the *de facto* standard for digital I/O boards, although the upper voltage limit that can be applied to digital inputs varies. The input circuits on some digital I/O boards are intended to be used with 0–5V signals, so they are protected with internal diodes that clip signals greater than 5.5 V or less than –0.5 V. Although these diodes provide adequate protection against occasional transients, they are not intended to dissipate significant amounts of energy. Signals far outside TTL limits can damage the board and/or the signal source. Therefore, it's important to use proper interfacing when dealing with non-TTL logic levels.

Signals in the range of 0–12VDC, such as those found in CMOS digital circuits, cannot be connected directly to TTL inputs. Possible solutions include the use of the CD4049 hex inverting buffer or CD4050 non-inverting buffer, which are designed to convert CMOS to TTL logic levels (**Figure 5-7**).

### 5.3.6 Digital High Current or High Voltage

If an output load requires more current or a higher voltage than a digital board can provide, the drive current and/or voltage can be boosted using the circuit shown in **Figure 5-8**. For drive current requirements from 15mA to 100mA, select an NPN transistor rated for the required supply voltage with a collector current rating no higher than 0.5A. If higher current is needed, substitute a Darlington NPN transistor.

Solid-state relay modules allow TTL signals to control outputs up to 250VDC or 280Vrms and to read inputs up to 280VDC/VAC as a TTL sig-

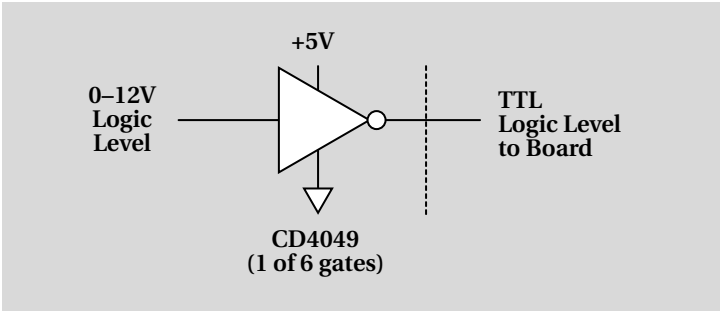

Figure 5-7. CMOS-to-TTL buffer/inverter

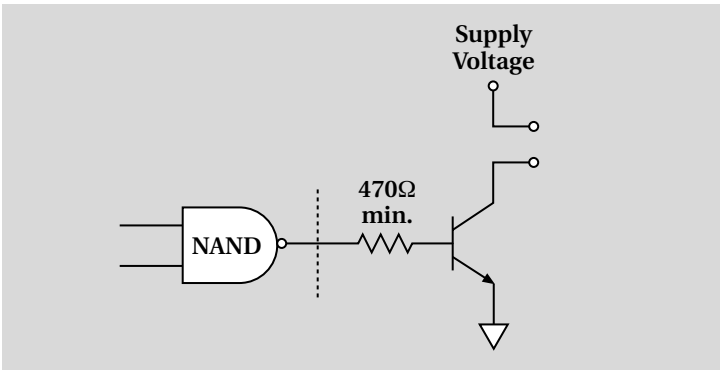

Figure 5-8. High voltage or high current drive for TTL gate

nal. These modules have two additional advantages: they are usually mounted on external circuit boards, which locates these elevated voltages at a distance from the computer, and they provide up to 4000V of electrical isolation. Isolation ensures that the test and measurement equipment can handle signals referenced to different grounds safely.

Solid-state relay modules also offer an advantage in controlling inductive AC loads such as solenoids. Unlike mechanical relays, where contacts can be subjected to large voltage arcs when they are opened, the solid-state relay will continue to carry current until it drops to zero, then turn off.

### 5.4 Isolation

*Electrical isolation* refers to a condition where no electrical connection or any common reference exists between two signals. An isolated measurement is a measurement performed without an electrical connection between the signal source and the data acquisition input chan-

nel. Similarly, isolated control involves no electrical connection between the control circuitry and the equipment being controlled. This isolation includes the signal and ground connections.

Isolation is possible for both analog and digital measurements and can be beneficial or necessary in a number of situations:

- A voltage differential exists between the grounds of the data acquisition system and external equipment. If this difference is large enough, it could lead to measurement problems or equipment failure.
- The external equipment contains internal voltages that could damage the data acquisition system in the event of equipment failure.

Electrical isolation specifications range up to thousands of volts. The specified voltage gradient can exist between the isolation circuits, with little or no leakage current between them.

### 5.4.1 Digital Isolation

Digital isolation is simpler and less expensive to implement than analog isolation. **Figures 5-9** and **5-10** show methods suitable for isolating digital inputs and outputs. Both use an opto-isolator that provides an electrical barrier between the digital input or output and the external equipment. Note that both circuits maintain separate grounds and power supplies on each side of the isolation barrier.

In the case of the isolated digital input in **Figure 5-9**, the diode side of the opto-isolator is powered and controlled by external equipment,

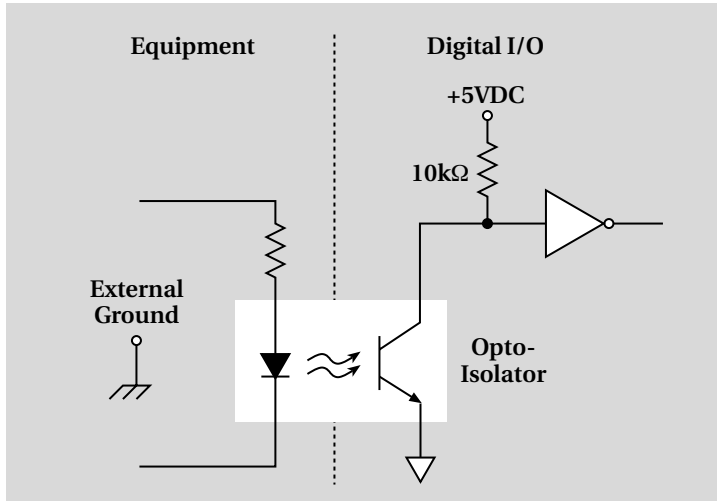

Figure 5-9. Isolated digital input

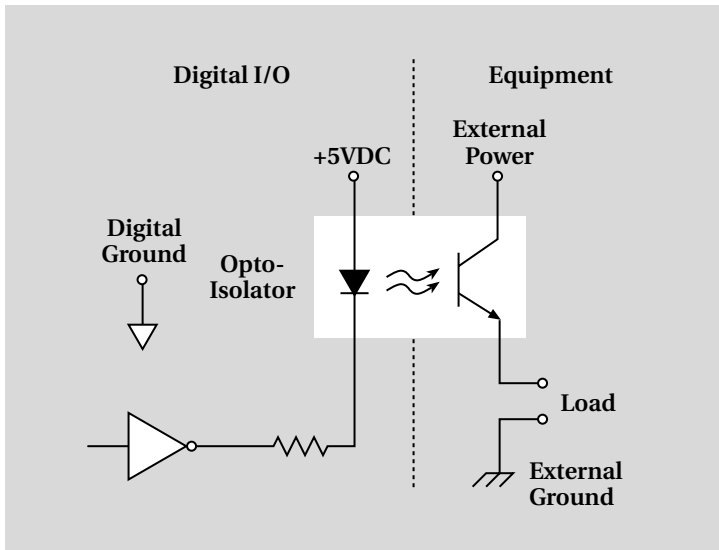

Figure 5-10. Isolated digital output

while the transistor switch in the isolator controls a digital input. For the isolated output shown in **Figure 5-10**, a digital output channel controls the opto-isolator diode, while the opto transistor switches power to external equipment. Generally, opto-isolators are low-power devices, but they can be connected to a relay, power transistor, or other device capable of controlling higher currents or voltages.

These circuits can be added externally to digital I/O channels, although some test and measurement boards and instruments offer isolated channels. External, solid-state, or mechanical relays can also provide digital isolation.

#### 5.4.2 Analog Isolation

Although analog isolation can be desirable for the same reasons as digital isolation, the nature of analog signals makes isolation more complex. Typically, isolation of analog signals involves converting the signal into a form that can be coupled from one circuit to another without physical connection. Further, the complexity and space requirements of analog isolation make it difficult to implement a multichannel isolated analog input board that plugs into a PC. It is also questionable practice to plug a board that carries high voltages or other potentially dangerous signals into a PC. Therefore, it is more common to find isolated analog I/O channels on external or industrial data acquisition systems where adequate room is available for circuit boards.

## 5.5 Ground Loops

Improper grounding is a common source of problems affecting analog measurements. A perfect circuit ground sits at 0V with reference to earth ground and represents an impedance of  $0\Omega$  at any frequency. In reality, a good DC ground requires some effort to achieve and still may not constitute a perfect ground at all frequencies.

When a piece of equipment is plugged into a three-wire grounded AC outlet, in theory, the chassis is at ground potential. However, there can be a considerable electrical path and a slight but significant resistance between the chassis and true ground. No problems should result as long as the chassis is used as a central grounding point for all other sensors and equipment. When instruments, sensors, and other components of a data acquisition system are plugged in AC mains at different physical locations in a facility, the chassis of each can be established at a slightly different ground potential. The resulting voltage gradient between these different grounds can cause current to flow through cable shields or other parts of the ground system, resulting in a ground loop (Figure 5-11).

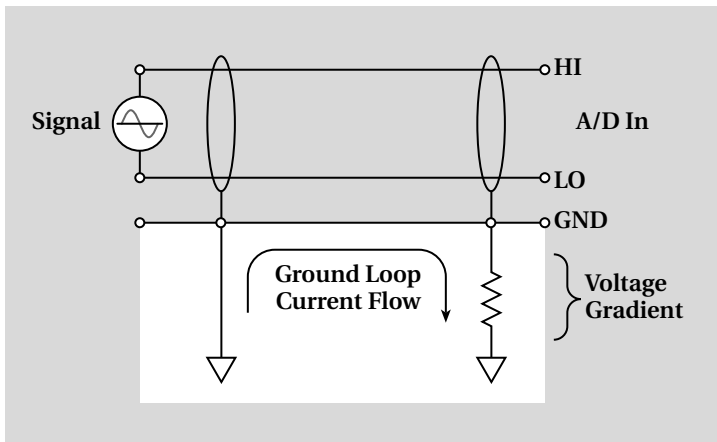

Figure 5-11. Ground loop

Ground loops can occur in any type of measurement setup, but are most troublesome for analog measurements. For single-ended measurements, ground loops result in current flow through circuit common or cable shields. In the case of differential measurements, the voltage gradient can add to the common mode voltage. As a result, measurements can be degraded through noise or suffer from reduced signal input range.

Follow these practices to minimize the possibility of ground loops:

- Where possible, use a single AC distribution strip and AC line cords of similar length to power equipment. Make sure all line cords are in good condition and that ground pins are present on three-conductor AC line cords.
- Use a single location as the central ground point for the entire test setup.
- When using shielded cables, connect the shield at only one end of the cable.
- Keep signal wiring and cabling as short as possible and avoid looping excess cable.

While still a valid concern, ground loops are less critical for digital signals because the large voltage difference between logic levels reduces the possibility of misinterpreting a signal. Be sure, however, that all digital grounds (except for isolated inputs) and the grounds of any auxiliary power supplies for accessories are connected to the digital I/O instrument's ground reference.





---

SECTION 6

Temperature  
Measurement

---

## 6.1 Temperature

Temperature is one of the most frequently measured physical phenomena. Several sensor technologies are available for this purpose, including thermocouples, resistive temperature detectors (RTDs), thermistors, and various semiconductor devices. The measurement range, accuracy, and ease-of-use of these sensors differ considerably, so the best choice of a sensor depends on the application and temperature range.

## 6.2 Thermocouples

Thermocouples are probably the most widely used sensor for temperature measurement; they are used in labs, industry, and even consumer devices. As such, thermocouples are used in a large base of data acquisition applications, including those employing many channels, automated data logging, and process control, to name a few. Thermocouple cards are also available for mainframe scanners, making it possible to add temperature monitoring to bench-type or rack-based systems. Even some low cost, hand-held DMMs have thermocouple inputs to support temperature monitoring.

### 6.2.1 Features and Operating Principle of the Thermocouple

Despite their widespread use, thermocouples may be the least understood of temperature sensors. When compared to some temperature sensors (notably, semiconductor types), thermocouples are easy to work with and are based on a simple operating principle. However, there are many different types of thermocouples, and special attention to metallurgy, operating principles, limitations, and treatment of measurement data is required to achieve valid results.

#### 6.2.1.1 *Advantages and Disadvantages of Thermocouples*

Thermocouples offer several advantages over other types of temperature sensors:

- The basic thermocouple is relatively inexpensive, although protective sheaths, cabling, and connectors can contribute to overall expense.
- Thermocouples are mechanically simple, durable, and reliable. Properties of typical metals used in thermocouples provide predictable output voltages. This allows users to adapt thermocouples to a variety of applications, including those in reactive or caustic environments.
- The physical construction of a basic thermocouple is simple—all that's necessary is twisting together wires of the appropriate alloys. Commercial thermocouples are assembled through welding, crimping, or soldering. All methods produce similar results.

- Thermocouples lend themselves to a variety of packaging techniques that can be adapted to many types of applications.
- Thermocouples offer a very wide overall temperature measurement range, spanning about  $-100^{\circ}\text{C}$  to higher than  $2500^{\circ}\text{C}$ .
- The typical accuracy of thermocouples is on the order of  $\pm 1-2^{\circ}\text{C}$ , which is more than adequate for the accuracy requirements of most industrial applications.

While thermocouples have relatively few disadvantages, these disadvantages affect their usage and the hardware needed to read them significantly. Thermocouple output is on the order of microvolts per degree, and thermocouples are sometimes located far from the data acquisition equipment. In order to compensate for these factors, differential measurement mode, high gain, filtering, and other signal conditioning techniques are used to maximize the signal and minimize noise. These practices result in relatively slow measurement rates for thermocouples, typically, a maximum of only a few hundred readings per second. Furthermore, thermocouple output is non-linear, so linearization routines must be built into the hardware and/or software used to convert thermocouple voltages to a temperature reading. This is more of a concern for custom-written software, because commercial software normally provides linearization capabilities.

Finally, thermocouple measurements require the use of a reference junction. Rather than resorting to a separate thermocouple junction and reference temperature for each channel, A/D boards designed for thermocouples usually incorporate an isothermal block with an embedded reference temperature sensor. The isothermal block provides a large thermal mass, which ensures that all thermocouple terminals on the A/D board are at the same temperature. Although these features result in higher complexity and higher hardware costs, they simplify the use of thermocouples.

### **6.2.1.2 Operating Principle of the Thermocouple**

In the early 1800s, Thomas Seebeck discovered that the junction between two metals generates a voltage that is a function of temperature. A thermocouple is simply a practical application of the “Seebeck Effect.” It is a temperature sensor that consists of two wires of dissimilar metals joined at one end. These metals are shown as “Alloy 1” and “Alloy 2” in **Figure 6-1** and form junctions J1 and J4.

Historically, temperature measurement with thermocouples relied on a second thermocouple element to sense a known temperature as a reference. The easiest and most precise way of producing a reference temperature was to immerse this reference junction (J4) in an ice bath, which gave it the name “cold junction.” The magnitude of the voltage generated in this scenario now depends on the temperature difference

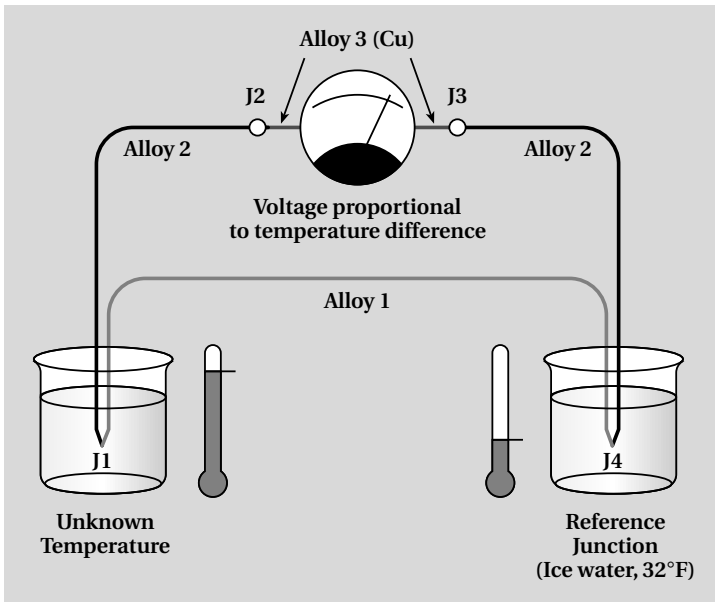

Figure 6-1. Thermocouple (Seebeck) principle.

between J1 and J4, and the types of metals used for Alloy 1 and Alloy 2. The result can be expressed by the following equation:

$$V = \alpha (T_{\text{UNKNOWN}} - T_{\text{REF}})$$

where  $\alpha$  is the Seebeck Coefficient. Different types of thermocouples have different coefficients, which are listed in most thermocouple references. With this configuration, it was only necessary to read the voltage, then look up the corresponding temperature in a table for the Alloy 1/Alloy 2 thermocouple type referenced to 0°C.

Note that the connection of the thermocouple to the voltmeter forms additional, potentially unwanted junctions J2 and J3. In effect, these junctions are also thermocouples, but they are of like composition and opposing polarities. If the temperatures of J2 and J3 are equal (a condition that can be reached relatively easily through proper hardware design), these junctions will have no effect on the measurement. We now have a basic model that can be used to develop a more sophisticated instrumentation system for reading thermocouples.

### 6.2.1.3 Simplifying the Measurement System

Elimination of the ice bath and corresponding reference junction for each thermocouple would be desirable for most applications, but particularly for industrial applications. It would not only simplify the use

of thermocouples, but eliminate the need for a potentially large number of additional data acquisition input channels and sensor readings for reference junctions.

As a first step in this process, we can assume that the thermocouple measurement instrument or data acquisition board has been designed and constructed so that its internal circuitry provides proper compensation against thermoelectric EMFs. This is, in fact, the case with good circuit designs, and even truer for those designed to read low-level voltages.

Next, we can concentrate on what happens between the input terminals and the thermocouple. The chief reason for immersing the reference junction in an ice bath was to force the junction to a known temperature ( $0^{\circ}\text{C}$ ). However, any temperature will suffice, as long as it is known. Recall from **Figure 6-1** that connecting the thermocouple to a voltmeter input introduces extra junctions into the circuit at the points of connection, each of which can also generate thermoelectric EMFs. Ideally, these terminals (J2 and J3) will be at the same temperature. This can be ensured by mounting them on an “isothermal block” that offers sufficient mass to withstand fluctuations in ambient temperature while maintaining the terminals at the same temperature (**Figure 6-2a**).

Next, we can move the reference junction out of the ice bath, onto the isothermal block to produce the circuit in **Figure 6-2b**. This ensures that the instrument terminals and the reference junction (J2, J3, and J4) are all at the same temperature. This temperature can be read with a sensor that does not require a reference junction, such as a thermistor or semiconductor temperature sensor in contact with the isothermal block. Thus, we have succeeded in eliminating the need for a separate reference temperature source and can measure the temperature of the terminals and the reference junction.

The final step in simplifying this thermocouple input circuit is to eliminate the length of Alloy 2 wire that extends from the reference junction (J4) to the instrumentation input (J3). The Law of Intermediate Metals states that a third metal inserted between two dissimilar metals of a thermocouple junction will have no effect on the output voltage, as long as the two junctions formed by the additional metal are at the same temperature. As these junctions are all mounted to the isothermal block, their temperatures are equal. The thermocouple junction in this case must be visualized as being formed by copper and Alloy 1, with Alloy 2 as the intermediate metal.

By removing Alloy 2, we have achieved the input circuit commonly used for modern thermocouple instrument inputs (**Figure 6-2d**). A fixed reference temperature and thermocouple are no longer required because a non-thermocouple reference sensor is now used to read the temperature of the isothermal block and input terminals. Multiple

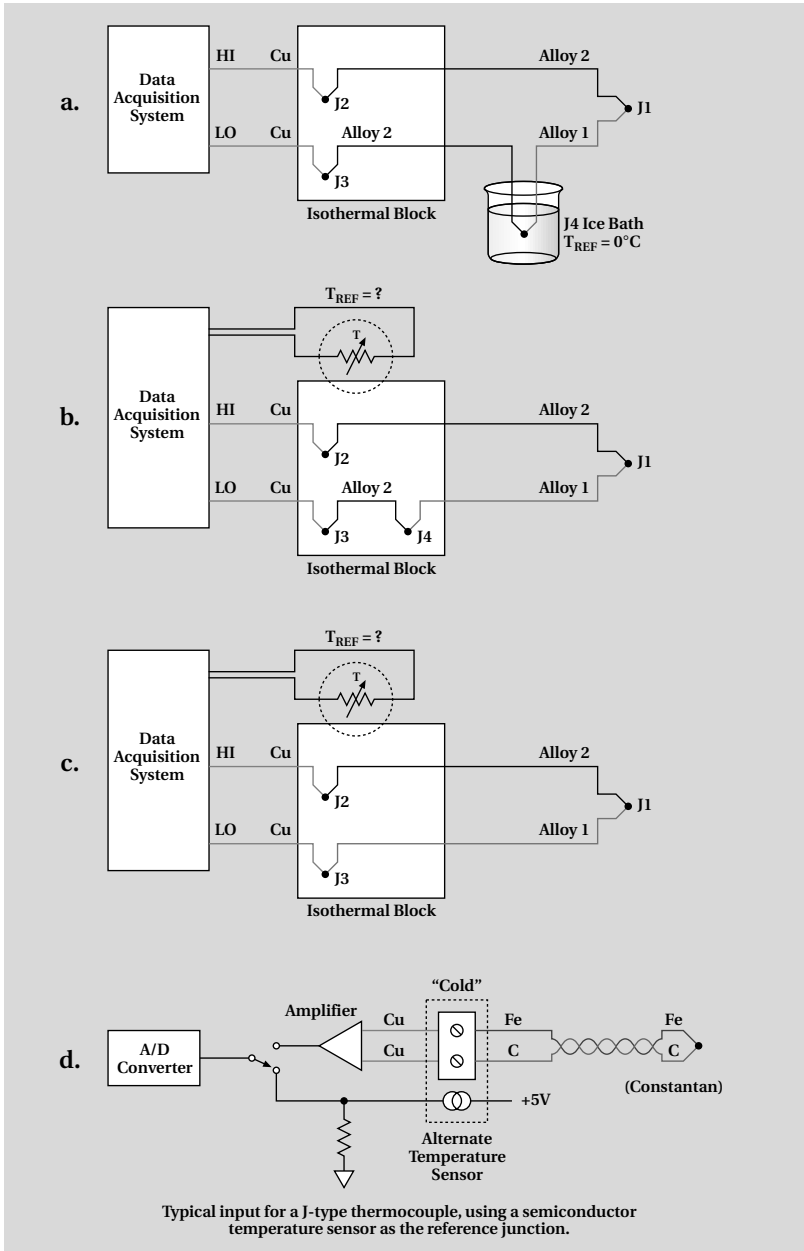

Figure 6-2. Development of a typical thermocouple instrument input

thermocouple inputs can be populated on the isothermal block, and the reference temperature sensor used to compensate all of them.

#### 6.2.1.4 Linearization

Within the usable temperature range of any thermocouple, there is a proportional relationship between thermocouple voltage and temperature. However, this relationship is by no means a *linear* one. In fact, most thermocouples are extremely non-linear over their operating ranges. In order to obtain temperature data from a thermocouple, it is necessary to convert the non-linear thermocouple voltage to temperature units. This process is called “linearization.”

Several methods are commonly used to linearize thermocouples. At the low cost end of the solution spectrum, one can restrict the thermocouple operating range to where the thermocouple is nearly linear. At the opposite end of the spectrum, special thermocouple interface components (integrated circuits or modules) are available to perform both linearization and reference junction compensation in the analog domain. In general, neither of these methods is well-suited for cost-effective, multi-point data acquisition systems.

In addition to linearizing thermocouples in the analog domain, it is possible to perform such linearizations in the digital domain. This is accomplished by either piecewise linear approximations (using look-up tables) or arithmetic approximations or, in some cases, a combination of these two methods. For example, to demonstrate how thermocouple linearization is typically performed in the digital domain, let’s look at a simple example. Let’s assume that we have the hot junction of a Type J thermocouple in boiling water at 100°C and the cold junction, near the measuring device, at room temperature of 25°C. Obviously, the system should provide a final answer of 100°C. The following describes the steps leading to that answer.

First, the following equation determines the measured output of the thermocouple:

$$V_{\text{measured}} = V_{\text{hot}} - V_{\text{cold}}$$

where:  $V_{\text{measured}}$  is the voltage measured by the data acquisition instrument

$V_{\text{hot}}$  is the voltage of the hot junction based on the look-up tables, and

$V_{\text{cold}}$  is the voltage of the cold junction read from the look-up tables as well.

According to Type J look-up tables, which always assume a 0°C reference:

$$V_{\text{hot}} (100^\circ\text{C}) = 5.278\text{mV}$$

$$V_{\text{cold}} (25^\circ\text{C}) = 1.019\text{mV}$$



Therefore, the voltage read by the data acquisition instrument would be:

$$V_{\text{measured}} = 5.268 - 1.019 = 4.249\text{mV}$$

In reality, given that the hot junction temperature is unknown (100°C), the reverse process is applied. The data acquisition device takes two voltage measurements: one from the thermocouple (4.249mV) and another one from the cold reference junction  $V_{\text{new}}$  (note that  $V_{\text{new}}$  is different from  $V_{\text{cold}}$ ). Then, the software would take over; it would convert the  $V_{\text{new}}$  to an actual cold junction temperature,  $T_{\text{cold}}$  (25°C), based on the properties of the cold junction sensor. Having  $T_{\text{cold}}$ , the software would figure out the equivalent voltage (1.019mV) according to the Type J look-up tables. It would then add this voltage to the measured voltage (1.019 + 4.249 = 5.268mV) to obtain the final hot junction voltage. The final step would be to convert the hot junction voltage (5.268mV) to an actual temperature (100°C) by using the same Type J look-up tables.

### 6.2.1.5 *Thermocouple Alloys, Extensions, Terminal Pins, and Other Interconnects*

When thermocouples are connected to data acquisition board terminals or other readout devices, the connections form additional junctions that can generate unwanted thermoelectric voltages. A copper terminal pin plugged into a copper socket will not generate a thermoelectric EMF. However, a constantan pin or socket crimped to a copper wire results in a J-type thermocouple junction that *will* generate a thermoelectric EMF. Extension wire and connector pins made from thermocouple metals are available to permit connection of like metals. Attention must be paid to every conductor and termination throughout a thermocouple circuit to ensure that unwanted junctions are not introduced into the circuit.

Also note that the purity of alloys directly affects the accuracy of temperatures calculated from a junction voltage. The wire used for making sensors has a higher accuracy than the “extension grade” thermocouple cabling used for long cable runs. It’s important to keep this fact in mind when constructing thermocouple circuits.

### 6.2.2 **Physical Construction of Commercial Thermocouples**

In addition to the wire alloy selection, packaging may affect the suitability of a thermocouple to a given application. A working thermocouple can be made by twisting together the stripped ends of a pair of thermocouple wires. However, the most reliable and consistent operation is provided by thermocouples that have been welded. Real-world applications often require that thermocouples be enclosed and protected from the environment or fitted with mounts, probe tips, or other features that best suit a specific application. The sheath is extremely important because it protects the thermocouple element from con-

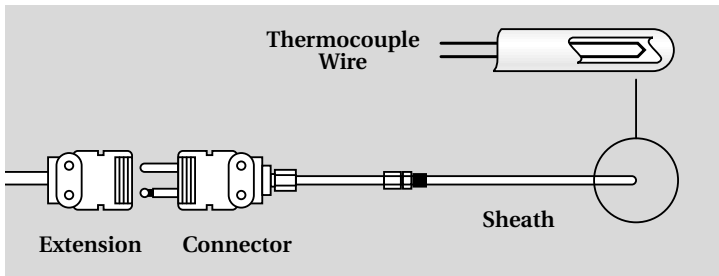

Figure 6-3. Typical industrial thermocouple

tamination and physical damage due to caustic materials, liquids, and other environment elements. Common sheath materials include iron, steel, stainless steel, iconel, ceramics, and porcelain. **Figure 6-3** shows one of several typical industrial thermocouple designs.

- **Thermocouple Element:** Two wires of dissimilar alloys that produce a voltage when exposed to a temperature gradient.
- **Sheath:** A tube of metal or other material, usually closed at the end, which protects the thermocouple element from the environment.
- **Terminal Block:** The connector assembly (optional) that facilitates connection of the thermocouple to the measurement instrument or a thermocouple extension. The physical design of the terminal pins prevents backward connection.
- **Thermocouple Extension:** An extension wire manufactured from metal alloys compatible with the thermocouple element.

Temperature range must also be considered when choosing sheath materials; some are better suited to high temperatures or offer greater service life in hostile environments. Likewise, the insulation on thermocouple and extension wire must be evaluated for its ability to withstand temperatures and physical abuse encountered in an application.

Another important point to consider with thermocouples is the mechanical and electrical interface between the thermocouple element and the outside world:

- **Exposed Junction:** Thermocouple wires are unprotected. Overall, the sensor possesses a lower thermal mass and is directly exposed to outside media, so it responds the fastest to temperature changes.
- **Grounded Junction:** Thermocouple wires are completely enclosed within and joined to the thermocouple sheath. The grounded junction provides medium response time and an electrical connection to the sheath.

- **Ungrounded Junction:** Thermocouple wires are completely enclosed within the thermocouple sheath, but are electrically isolated from the sheath. The ungrounded junction is the slowest to respond to temperature changes.

The overall response time of a thermocouple depends not only on the tip design, but also on the sheath material and diameter, and the surrounding medium. Response times can vary from a tenth of a second to several seconds.

## 6.2.3 Thermocouple Types and Applications

Several different metal alloys are used to construct thermocouples. Each alloy offers characteristics that are advantageous for specific applications. As shown in **Table 6-1**, these alloys have been assigned a series of standardized letter codes. Each type of thermocouple wire can be identified by a color code for the individual conductors. There are several color coding systems used around the world, but most indicate the negative thermocouple lead with red. However, the colors of the positive conductor, thermocouple wire jacket, and extension wire jacket can vary. The color code system used in the United States is shown in **Table 6-2**.

### 6.2.3.1 Base Metal Thermocouples

Thermocouple types J, K, N, E, and T are economical, reliable, and reasonably accurate. These types represent more than 90% of all thermocouples. They are well suited for temperatures ranging from  $-200^{\circ}$  to  $1700^{\circ}\text{C}$ .

- **Type E:** Suitable for  $-200^{\circ}$  to  $871^{\circ}\text{C}$ . Applicable to atmospheres ranging from vacuum to mildly oxidizing, and for very low temperatures. Type E provides the highest output of any of the base metal thermocouples.
- **Type J:** Suitable for lower temperatures ( $0^{\circ}$  to  $600^{\circ}\text{C}$ ). Should not be used above  $760^{\circ}\text{C}$ . Economical and reliable. Popular in the plastics industry, but useful as a general-purpose thermocouple within the prescribed temperature range.
- **Type K:** Industry standard for temperatures up to  $1250^{\circ}\text{C}$ . Can corrode in chemically reducing environments.
- **Type N:** Similar to Type K but more resistant to oxidation.
- **Type T:** Suitable for  $-200^{\circ}$  to  $350^{\circ}\text{C}$ . Commonly used in food processing industry.

### 6.2.3.2 Noble Metal Thermocouples

Thermocouple types R, S, and B are constructed of platinum and rhodium, so they are referred to as “noble metal thermocouples.” As a class, these thermocouples are more accurate and stable than base metal types, but also more expensive. They are used for applications up

*Table 6-1. Thermocouple types*

Type	Gauge	°F Range	°C Range
J (Iron vs. Constantan)	8	-70 to 1400	-57 to 760
	14	-70 to 1100	-57 to 593
	20	-70 to 900	-57 to 482
	24	-70 to 700	-57 to 371
K (Chromel vs. Alumel)	8	-70 to 2300	-57 to 1260
	14	-70 to 2000	-57 to 1093
	20	-70 to 1800	-57 to 982
	24	-70 to 1600	-57 to 870
N (Nicrosil vs. Nisil)	8	-70 to 2300	-57 to 1260
	14	-70 to 2000	-57 to 1093
	20	-70 to 1800	-57 to 982
	24	-70 to 1600	-57 to 870
T (Copper vs. Constantan)	14	-70 to 700	-57 to 371
	20	-70 to 500	-57 to 260
	24	-70 to 400	-57 to 200
E (Chromel vs. Constantan)	8	-70 to 1600	-57 to 871
	14	-70 to 1200	-57 to 649
	20	-70 to 1000	-57 to 538
R, S Platinum vs. Platinum/13% Rhodium	24	-50 to 2650	-46 to 1454
B (Platinum/6% Rhodium vs. Platinum/30% Rhodium)	24	32 to 2650	0 to 1454

*Table 6-2. Thermocouple color codes, United States*

Type	(+) Conductor	(-) Conductor	Thermocouple Jacket	Extension Jacket
J	White	Red	Brown	Black
K	Yellow	Red	Brown	Yellow
N	Orange	Red	Brown	Orange
T	Blue	Red	Brown	Blue
E	Purple	Red	Brown	Purple
R	Black	Red	—	Green
S	Black	Red	—	Green
B	Gray	Red	—	Gray

to 1700°C, and as references for testing other types. To avoid the possibility of contamination at high temperatures from metal vapors, they should be used inside a non-metallic sheath.

- **Type R:** Industrial standard for high temperature (to 1450°C). Prone to contamination when contacting other metals. Stable in oxidizing atmospheres, but degrade rapidly in vacuum or reducing atmospheres.
- **Type S:** Similar to Type R. Not used extensively as an industrial sensor.
- **Type B:** Similar to Types R and S, but useful to 1700°C. Best used at temperatures higher than 250°C. A weak, non-linear output at low temperatures and a “dip” in output voltage from 0°C to 50°C make the B type thermocouple unusable at temperatures less than 50°C.

### 6.2.3.3 Other Types of Thermocouples

Type C, D, and E thermocouples are more difficult to use because of their brittle nature and susceptibility to oxidation and breakage. These types must be used in inert atmospheres, and are useful to 2315°C.

- **Type C:** Tungsten/5% Rhenium vs. Tungsten/26% Rhenium
- **Type D:** Tungsten/5% Rhenium vs. Tungsten/26% Rhenium
- **Type G:** Tungsten vs. Tungsten/26% Rhenium

## 6.3 Resistive Temperature Detectors

Resistive Temperature Detectors (RTDs) are among the most stable and accurate temperature sensors available. RTDs offer a narrower measurement range than thermocouples, covering approximately -200°C to +800°C. The actual range for a particular RTD depends on its composition and construction, but won't vary appreciably from this range.

RTDs are used where high accuracy and repeatability are required, such as in food, laboratory, and pharmaceutical applications. Accuracy

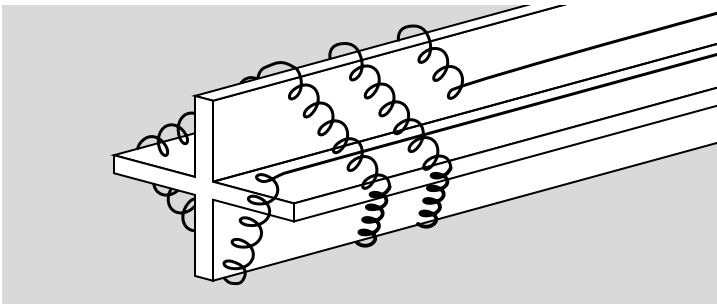

Figure 6-4. Simple RTD

is often expressed as a percentage of resistance at a specified temperature. For instance, a “Class B” RTD is specified by the International Electrotechnical Commission (IEC) as  $100\Omega \pm 0.12\%$  at  $0^\circ\text{C}$ . IEC Class A accuracy provides  $\pm 0.15^\circ\text{C}$  at  $0^\circ\text{C}$ . However, the calibration is performed at two or more temperatures suitably spaced over the stated RTD working range. Frequently, an interchangeability tolerance is also specified for RTDs. This specification indicates the maximum tolerance error an RTD of a particular design will have. A typical value is  $\pm 0.1^\circ\text{C}$ .

### 6.3.1 Construction

Several techniques are used to manufacture RTDs. These techniques provide various tradeoffs between cost, durability, ease-of-use, and performance.

The classic RTD configuration is a length of platinum wire wound on a glass or ceramic bobbin (**Figure 6-4**). The RTD is then encapsulated in glass or other protective material.

A second variety of RTD is constructed by depositing a conductive film on a non-conductive substrate, which is then encapsulated or coated to protect the film. RTD assemblies often include connectors, metallic sheaths, and handles that make them resemble thermocouple probes.

### 6.3.2 Principle of Operation

RTDs are based on the principle that the resistance of most metals increases with an increase with temperature. An ideal metal for RTDs would exhibit the following characteristics:

- High resistivity (resistance per unit of length), which minimizes the amount of wire required to provide a high resistance.
- The change in resistivity vs. temperature is adequate to provide the desired measurement resolution.
- The change in resistivity is linear, simplifying the conversion to a corresponding temperature.
- Mechanical properties and durability of the metal facilitate construction and ensure the reliability of the measurement device.

Tungsten, nickel, and platinum all possess relatively high resistivities. However, tungsten is fragile and nickel has a non-linear response. Platinum wire is fragile, but it is only slightly non-linear in its response. Platinum is highly resistant to contamination and exhibits a predictable change in resistance with temperature. Therefore, most general-purpose RTDs are made of platinum wire.

The resistance of platinum RTDs ranges from tens of ohms to several thousand ohms, but most platinum RTDs have been standardized to a value of  $100\Omega$  at  $0^\circ\text{C}$ . Depending on the purity of the platinum

used, the temperature coefficient ( $\alpha$ ) of a platinum RTD is  $0.00385\Omega/\Omega/^\circ\text{C}$  (the European curve) to  $0.00392\Omega/\Omega/^\circ\text{C}$  (American curve).

### 6.3.3 Application of RTDs

Unlike a thermocouple, an RTD needs no reference junction. It might seem a simple matter to connect a standard DMM to the RTD, measure the resistance of the RTD, then convert to a corresponding temperature. In practice, the resistive properties of the RTD and associated wiring usually require sensitive instrumentation optimized for low resistance measurements. For example, a  $100\Omega$  RTD having  $\alpha = 0.00385\Omega/\Omega/^\circ\text{C}$  produces a resistance change of only  $100\Omega \times 0.00385\Omega/\Omega/^\circ\text{C}$  or  $0.385\Omega/^\circ\text{C}$ . The wire leads connecting the RTD to the ohmmeter might have a value of several ohms. With a  $100\Omega$  RTD,  $1\Omega$  amounts to an equivalent temperature error of about  $2.5^\circ\text{C}$ .

Traditionally, RTDs have been implemented either as part of a Wheatstone bridge (ratiometric) circuit or in a four-wire (direct voltage or resistance measurement) configuration. Both methods are capable of minimizing the effects of lead resistance to provide accurate readings, but each imposes certain requirements. Wheatstone bridges require additional resistive components to complete the bridge and the resistance of wire leads from the bridge to the RTD must also be taken into consideration (**Figure 6-5**). The bridge design shown in **Figure 6-6** is a refinement of the basic bridge and uses a separate voltage sensing lead from the voltmeter to the RTD to minimize the effects of lead resistance (a three-wire arrangement). Further developing and simplifying the bridge produces the four-wire measurement circuit in **Figure 6-7**. Here, a current source is used to excite the bridge.

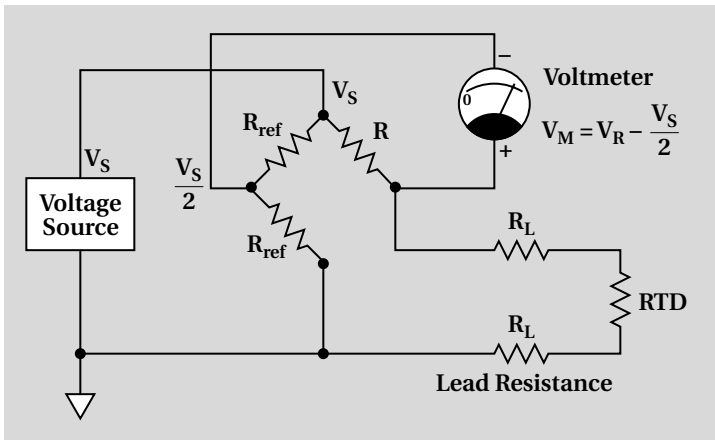

Figure 6-5. Bridge with two-wire RTD

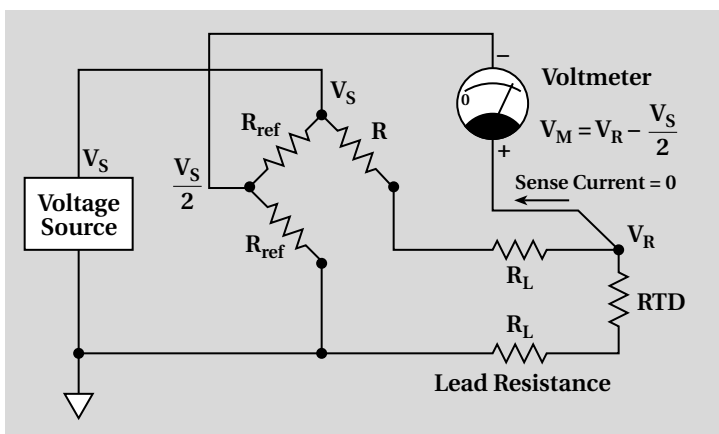

Figure 6-6. Bridge with three-wire RTD

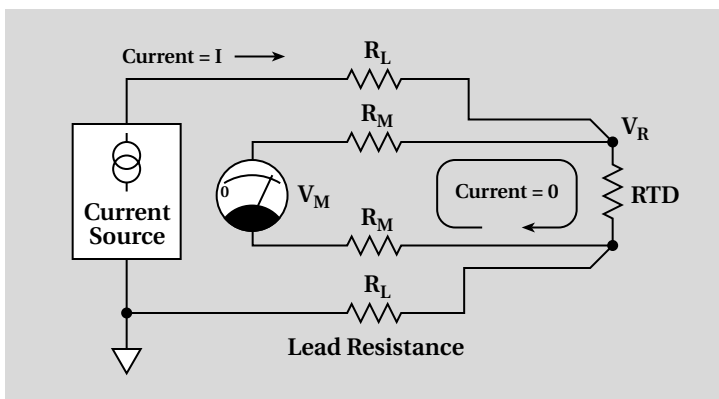

Figure 6-7. Four-wire RTD

Today, RTDs are available in two-, three-, or four-wire models to accommodate the corresponding measurement configuration, although advances in instrumentation and data acquisition hardware have largely eliminated the need to build bridge circuits. Typically, modern RTD analog input modules or plug-in boards provide a regulated excitation source, plus terminals that can be set up for two-, three-, or four-wire RTD configurations. The software and drivers for these boards usually contain algorithms to convert raw data to temperature, greatly simplifying the manipulation and conversion of test data. When a precision ohmmeter is used to read RTD resistance values, the equivalent circuit approximates **Figure 6-7** closely. Such



meters usually offer a four-wire measurement mode, and use an on-board excitation source optimized for precise, high resolution measurements of low resistances.

The following subsections describe the theory and calculations for three-wire and four-wire RTDs. These are offered for reference purposes. The two-wire RTD is not discussed in detail here, although a diagram of it is shown in **Figure 6-5**. The two-wire configuration is more suitable for applications where the distance from the bridge to the RTD is short and some measurement error can be tolerated. Higher gauge lead wires can be used to minimize these errors. However, the four-wire RTD configuration is recommended in most applications.

### 6.3.4 Three-Wire Bridge Configuration

**Figure 6-6** illustrates a Wheatstone bridge containing a three-wire RTD. The standard method of using a Wheatstone bridge for other applications involves balancing the bridge so that the voltage ( $V_M$ ) measured across the bridge is 0. However, an RTD's value shifts with temperature, so a bridge containing an RTD will not necessarily be balanced.

Calculations of RTD resistance can be simplified if we first apply a few constraints to the circuit. First, selecting reference resistors ( $R_{ref}$ ) with the same value and composition will result in a reference voltage ( $V_S/2$ ) of half the supply voltage. Even if the temperature coefficient of these resistors is not 0, any temperature-induced drift should be in the same direction, resulting in a stable reference voltage. The other side of the bridge contains the RTD and a reference resistor ( $R$ ). Where possible, the value of  $R$  should be chosen to be close to the resistance of the RTD at the temperature of greatest interest.

The circuit in **Figure 6-6** shows an RTD with two lead wires connected to one end and a single lead connected to the other end. The additional lead allows the RTD bias circuit to be partially separated from the sensing circuit. If the current-carrying leads are of the same length and gauge, their resistances will tend to cancel when the RTD value equals resistor  $R$ .

The formula to determine the RTD's resistance in the three-wire configuration (with the RTD on the ground side of the bridge) is:

$$RTD = (R + R_L) \times \left[ \frac{(V_S + 2V_M)}{(V_S - 2V_M)} \right] - R_L$$

The current through the RTD side of the bridge is:

$$I_{RTD} = \frac{V_S + 2V_M}{2R}$$

If the RTD is on the supply side of the bridge, the formula is:

$$\text{RTD} = (R + R_L) \times \left[ \frac{(V_S - 2V_M)}{(V_S + 2V_M)} \right] - R_L$$

and the current through the RTD is:

$$I_{\text{RTD}} = \frac{V_S - 2V_M}{2R}$$

If  $R_L$  is known, it can be included in the formula. If  $R_L$  is not entered, the worst-case error for the value of the RTD will be about half that obtained in the two-wire configuration. As the value of the RTD approaches  $R$ , the error will approach zero—an advantage of choosing  $R$  equal to the RTD's value at the temperature of greatest interest.

### 6.3.5 Four-Wire RTD Configuration

Four-wire RTDs have two wire leads terminated at each end of the RTD element. The complete four-wire circuit shown in **Figure 6-7** uses a current source, rather than a voltage source. Current flows to the RTD through one pair of leads, while the voltage drop across the RTD is measured using the other pair of leads. Lead resistance ( $R_L$ ) has no effect on the current passing through the RTD. Furthermore, virtually no current flows in the measurement side of the circuit, so any error contributed by resistance of the measurement leads ( $R_M$ ) is insignificant as long as a high impedance analog input voltmeter is used.

The voltage ( $V_M$ ) measured across the RTD can be used to calculate the resistance of the RTD:

$$\text{RTD} = \frac{V_M}{I_{\text{RTD}}}$$

To minimize self-heating errors, the current should be limited to 1mA or less, meaning that  $V_M$  will be a maximum of 0.1V for a 100Ω RTD. Therefore, a high gain, low noise analog input channel will provide best results. Filtering or other forms of signal conditioning may be helpful.

### 6.3.6 Converting RTD Resistance to Temperature

There are two options for converting resistance to temperature. One is simply to consult a look-up table and find the temperature corresponding to a specific resistance. This method is workable in software programs where an event will be triggered at a certain temperature (the corresponding resistance or voltage can be used as a trigger level), but is not suitable for real-time readout of temperature based on RTD resistance values.

A second method of converting resistance to temperature is by means of an equation. The most commonly cited equation for this purpose is a polynomial that uses a set of constants called the Callendar-Van Dusen coefficients.

The general equation for the relationship between RTD resistance and temperature is:

$$RTD = R_0 [1 + At + Bt^2 + C(t - 100)^3]$$

where: RTD is the resistance of the RTD at temperature  $t$ ,

$R_0$  is the resistance of the RTD at  $0^\circ\text{C}$ , and

A, B, and C are the Callendar-Van Dusen coefficients shown in **Table 6-3**.

For temperatures higher than  $0^\circ\text{C}$ , the “C” coefficient is 0, and the equation becomes:

$$RTD = R_0 [1 + At + Bt^2]$$

If a current  $I_{RTD}$  is passed through the RTD, and the voltage  $V_{RTD}$  measured, this equation can be solved for  $t$ :

$$t = \frac{2 (V_{RTD} - I_{RTD}R_0)}{I_{RTD}R_0 \left[ A^2 + \sqrt{A^2 + 4B (V_{RTD} - I_{RTD}R_0) / I_{RTD}R_0} \right]}$$

**Table 6-3. Callendar-Van Dusen coefficients for common RTD alphas**

Standard	RTD			
	Temperature Coefficient ( $\alpha$ )	A	B	C*
DIN 43760	0.003850	$3.9080 \times 10^{-3}$	$-5.8019 \times 10^{-7}$	$-4.2735 \times 10^{-12}$
American	0.003911	$3.9692 \times 10^{-3}$	$-5.8495 \times 10^{-7}$	$-4.2325 \times 10^{-12}$
ITS-90	0.003926	$3.9848 \times 10^{-3}$	$-5.870 \times 10^{-7}$	$-4.0000 \times 10^{-12}$

\* Used for temperatures less than  $0^\circ\text{C}$  only. For temperatures higher than  $0^\circ\text{C}$ ,  $C = 0$ .

### 6.3.7 Excitation Current and Joule Heating

One aspect of using RTDs and most other resistive sensors is resistive (“joule”) heating that results from excitation current passing through the sensor (power = excitation current<sup>2</sup> × RTD resistance). Although the amount of heat energy may be slight, it can affect measurement accuracy nonetheless. Self-heating is typically specified as the amount of power that will raise the RTD temperature by  $1^\circ\text{C}$ . Its typical value is about  $1\text{mW}/^\circ\text{C}$ .

Inaccuracy caused by joule heating is aggravated by higher excitation currents and stagnant surrounding media of low specific heat. These effects can be minimized if the surrounding medium is in motion or is agitated to carry heat away from the RTD.

Typical RTD data acquisition boards supply an excitation current of  $100\mu\text{A}$  to  $1\text{mA}$  to minimize joule heating. A  $100\Omega$  RTD will pass a current of  $1.0\text{mA}$  when biased with only  $0.1\text{V}$ . While lower current is better, currents lower than  $100\mu\text{A}$  result in lower signal levels, which are more difficult to measure.

## 6.4 Thermistors

The thermistor (*thermally sensitive resistor*) is a second variety of resistive temperature detector commonly used in data acquisition applications. Although RTDs and thermistors are both resistive devices, they differ substantially in operation and usage.

Thermistors are passive semiconductor devices. Both negative temperature coefficient (NTC) and positive temperature coefficient (PTC) thermistors are available. The resistance of an NTC thermistor decreases as its temperature increases, while the resistance of a PTC thermistor increases as its temperature increases. For temperature measurement applications, NTC types are used more commonly than PTC thermistors.

Very small thermistors can be manufactured and this small size allows them to respond quickly to slight temperature changes. However, they can be prone to self-heating errors. Thermistors are also relatively fragile, so they must be handled and mounted carefully to avoid damage.

Thermistors offer a significantly broader range of base resistance values than RTDs do, with base resistance values of kilo-ohms to mega-ohms readily available. Compared to RTDs, the temperature coefficient of a typical thermistor is relatively large—on the order of several percent or more per degree Celsius. This high temperature coefficient results in a resistance change of up to several thousand ohms per degree Celsius. Therefore, the resistance of the wires connecting the instrumentation to the thermistor is insignificant, so special techniques such as high-gain instrument inputs and three- or four-wire measurement configurations are unnecessary to achieve high accuracy.

While thermistors have relatively few drawbacks associated with them, it's important to be aware of these limitations in order to achieve accurate, reliable measurements. For example, thermistors are relatively low temperature devices, with a typical measurement range of  $-50^{\circ}\text{C}$  to  $150^{\circ}\text{C}$ , although some thermistors can be used at temperatures up to  $300^{\circ}\text{C}$ . This range is significantly narrower than that of thermocouples and RTDs. Exposure to higher temperatures can decalibrate a thermistor permanently, producing measurement inaccuracies. Thermistors are highly non-linear in their response, and are not as standardized as thermocouples and RTDs. They tend to be more appropriate for applications that require sensitive measurements over a relatively restricted temperature range, rather than for general-purpose temperature measurements.

### 6.4.1 Thermistor Circuit Configuration

As discussed previously, thermistors have a higher base resistance value and a higher temperature coefficient of resistance than RTDs do.

Therefore, techniques such as four-wire configurations and sensitive measurement capability are required only in more critical thermistor applications, because any resistance in the test leads is relatively insignificant when compared to the resistance of the thermistor itself.

**Figure 6-8** shows a standard two-wire measurement setup. The calculation of the thermistor's resistance is a straightforward exercise in Ohm's Law. In cases where the series resistance of the lead configuration is significant, the four-wire configuration can be used. The current applied to the thermistor should always be limited to the minimum needed to produce a readable voltage.

### 6.4.2 Converting Thermistor Resistance to Temperature

The output of most thermistors is highly non-linear, and their response has been standardized much less than for thermocouples or RTDs. Therefore, manufacturers frequently supply resistance-temperature curves, tables, or constants for their specific products. Typical thermistor alphas ( $\alpha$ ) range from  $-2\%$  to  $-8\%$  per  $^{\circ}\text{C}$ , and are generally larger at the lower end of the temperature range. Linearized thermistors also

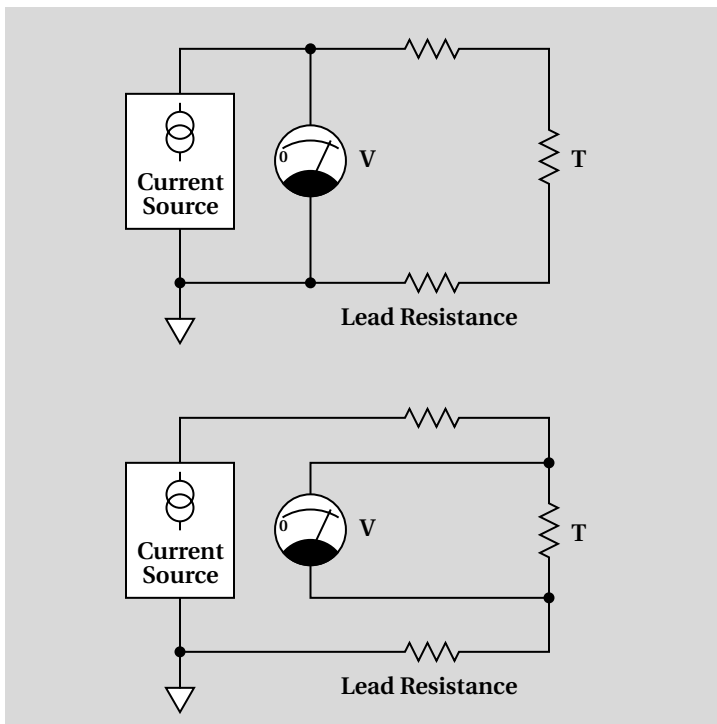

*Figure 6-8. Two- and four-wire thermistor circuits*

exist, although the use of computerized data acquisition systems and software make them unnecessary unless the readout hardware must be used with a linearized type.

For computerized applications, relatively accurate thermistor curves can be approximated with the Steinhart-Hart equation:

$$T = \frac{1}{A + B \times \ln(R_T) + C [\ln(R_T)]^3}$$

T is the temperature in degrees Kelvin, which is equal to the Celsius temperature plus 273.15.  $R_T$  is the resistance of the thermistor. The constants A, B, and C for a given thermistor should be provided by the thermistor manufacturer.

## 6.5 Semiconductor Linear Temperature Sensors

Monolithic linear temperature sensors constitute yet another type of temperature transducer. Typically, these sensors are two- to three-pin active electronic devices that operate from a nominal 5VDC to 30VDC supply voltage, and pass an output current or voltage proportional to temperature.

The first of these sensors were designed and calibrated such that current output increased linearly by  $1\mu\text{V}$  per Kelvin degree, with an output of 0V corresponding to 0K. These sensors are available in a variety of packages and models that provide voltage or current output. Later-generation devices are available scaled to read directly in Celsius or Fahrenheit values, eliminating the need to convert sensor output to the desired temperature scale.

The temperature range of monolithic linear temperature sensors is approximately  $-50^\circ\text{C}$  to  $150^\circ\text{C}$ , making them suitable for a relatively narrow range of temperatures as compared to thermocouples and RTDs. Within this range, output is extremely linear with respect to temperature, and no reference junctions or complex calculations are required to use them. Although these sensors require a power source, self-heating is a minor concern. Supply currents are generally in the range of  $75\text{--}100\mu\text{A}$ , so power consumption is very low, and typical maximum self-heating in still air is just  $0.1\text{--}0.2^\circ\text{C}$ .

Using solid-state temperature sensors is fairly straightforward. The current sensor in **Figure 6-9** is inserted in series with a resistor that provides a voltage drop that can be read by a digital voltmeter. The voltage sensor outputs a voltage directly.

## 6.6 Thermal Shunting

All temperature detectors possess some mass in the form of a sensor element, protective sheath or encapsulation, leads, and other physical components. When the sensor is placed in contact with a medium to

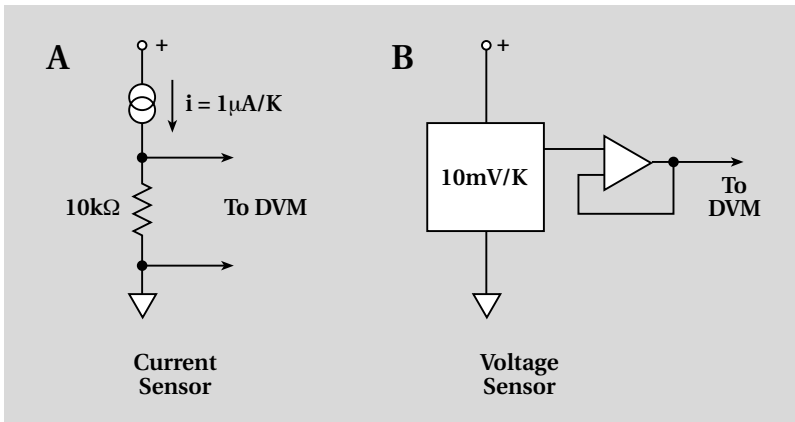

Figure 6-9. Semiconductor temperature sensors

measure its temperature, the sensor will absorb some heat energy from the medium, thereby altering its heat content and temperature. This process is called “thermal shunting.”

Thermal shunting can be minimized by using temperature sensors of the smallest possible mass. However, the choice sometimes imposes tradeoffs. For example, although thermocouples generally have lower mass than RTDs, they are less accurate. Powered resistive sensors of lower mass are more prone to joule heating than more massive sensors. Temperature sensors with lower mass can also be more susceptible to damage or other problems.

---

SECTION 7

**Strain  
Measurement**

---



## 7.1 Strain

Studying the physical behavior of mechanical structures frequently includes measuring a phenomenon known as “strain.” Strain is defined as a physical distortion of an object in response to one or more external stimuli applied to the object. Typical stimuli include linear forces, pressures, torsion, and expansion or contraction due to temperature differentials. Strain can result in elongation or contraction; these phenomena are noted by the use of a (+) sign for expansion or a (–) sign for compression.

Strain information is important in structural engineering because it can be used to determine the stress present in an object. Stress data can then be used to assess factors such as the structural reliability and service life of the object. The basic principle of strain measurement is also used in other types of force-related measurements, such as pressure, torque, and weight.

Strain is calculated as the change in length of an object divided by the unit length of the object. Normally, this change is extremely small in relation to the object’s length. For example, the length of a one-meter rod might change by only 0.01mm under compression. This change can be calculated as 0.01mm/1000mm, and is expressed as 0.00001 “strain” or ten microstrain.

$$\text{Strain } (\epsilon) = \frac{\Delta L}{L}$$

## 7.2 Poisson’s Strain

When a bar is strained with a force along the length, causing the bar to elongate, a phenomenon known as Poisson’s Strain causes the girth of the bar to contract. This contraction is a material property denoted by Poisson’s Ratio ( $\nu$ ) for the specific material (**Table 7-1**). Poisson’s Ratio is defined as the negative ratio of the strain in the transverse direction (perpendicular to the force) to the strain in the axial direction (parallel to the force) or  $\nu$ .

$$\nu = \frac{-\epsilon_t}{\epsilon}$$

In a half bridge or full bridge, one or two strain gauges can be mounted in the transverse direction, so that their resistance changes in response to Poisson’s Strain.

## 7.3 Strain Gauges

Strain is measured using strain gauge sensors. While there are piezoelectric and semiconductor strain gauges, the majority are passive resistive devices constructed by depositing or etching a wire or foil sensing grid on a substrate known as the *carrier matrix*. **Figure 7-1**

*Table 7-1. Poisson's Ratio for some common materials*

Material	Poisson's Ratio ( $\nu$ )
Aluminum	0.32
Red Brass	0.33
Cast Iron	—
Polycarbonate	0.285
Steel – 1018	0.285
Steel – 4130/4340	0.28–0.29
Stainless Steel - 304	0.25
Stainless Steel – 410	0.27–0.29
Titanium	0.34

illustrates one of the many varieties of strain gauges available. Gauges may be constructed with a single grid or with multiple grids, and in a variety of form factors. Furthermore, multiple grids can be arranged on the carrier matrix in a variety of patterns to allow measuring strain in different directions.

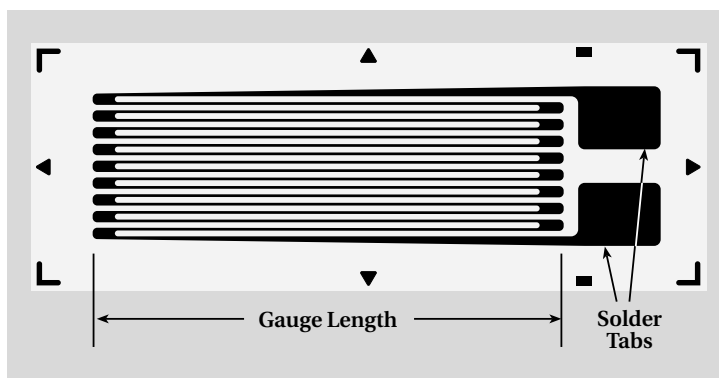

*Figure 7-1. A typical strain gauge*

Usually, strain gauges are attached to a test object using an adhesive designed to transmit strain from the object to the gauge, as well as to insulate the gauge and dissipate heat from the gauge to the object. A protective coating may also be applied to the outside of the mounted strain gauge to seal it from the environment.

Resistive strain gauges are used in a Wheatstone bridge configuration (**Figure 7-2**). The Wheatstone bridge is effective in detecting an imbalance between resistances comprising the bridge. However, a four-wire measurement setup similar to that used for RTDs can also be used for measuring the resistance of one strain gauge (see Section 6,

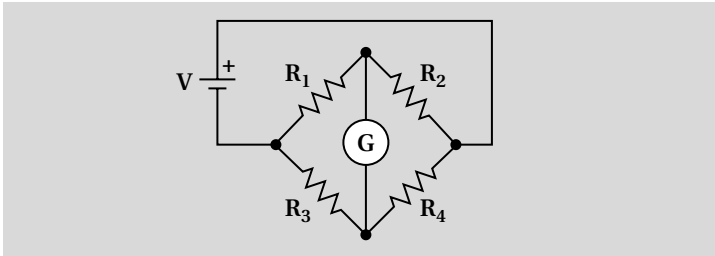

Figure 7-2. Wheatstone bridge configuration

Temperature Measurement). In this case, the strain gauge is excited using a current source and a precision microvoltmeter is used to measure the voltage drop across the gauge. This measurement can be used to calculate the change in resistance. A micro-ohmmeter can also be used to measure resistance directly.

The Wheatstone bridge strain gauge can contain one, two, or four active strain gauge elements (Figure 7-3,  $R_1$  through  $R_4$ ). The resistance value of a bridge constructed with four equal resistances is equal to the value of one of the bridge legs. Common bridge values include 120, 350, 600, 700, and 1000 ohms, but gauge values can vary from 25–30 ohms to several thousand ohms. At a given supply voltage, a higher resistance bridge will dissipate less heat than a lower resistance bridge, and the resistance of measurement leads will have less effect on accuracy.

Four active elements allow a bridge to produce the maximum imbalance and  $V_{OUT}$  for a given strain level, provided the elements are properly positioned on the structure. For bridges containing two active elements,  $V_{OUT}$  at a particular level of strain will be about one-half that of a bridge with four active elements. For a one-element bridge,  $V_{OUT}$  will be approximately one-fourth as great.

In the full bridge configuration, two gauges must be mounted on the tensile surface of the structure, with two more on the opposite compressive surface, so that two gauges increase in resistance while the opposite gauges decrease in resistance (Figure 7-4). Note that the gauge elements must be aligned with respect to the test object so that the sensing grid can detect flexing of the test object. Also note that different types of strain measurement, such as torsional and shear strain, can require different gauge orientations.

If only two active strain gauge elements are used in a bridge, one active element should be mounted on each side of the object (e.g., positions  $R_1$  and  $R_2$  or positions  $R_3$  and  $R_4$ ). The bridge should be completed with resistors with values and temperature characteristics similar to the active element(s).

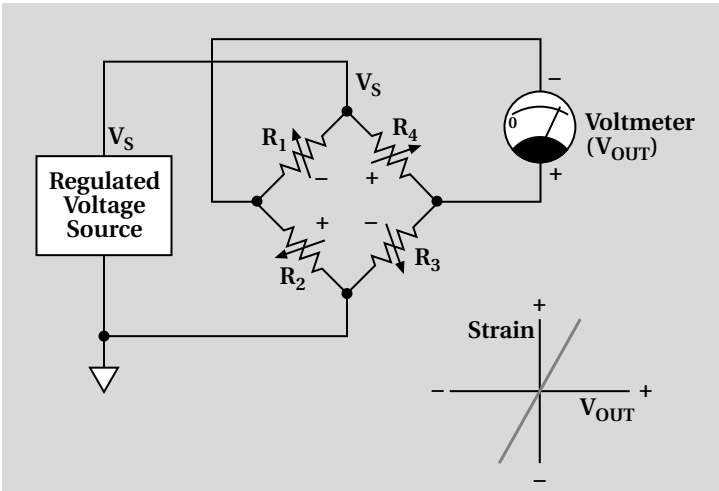

Figure 7-3. Strain gauge bridge with four strain gauge elements

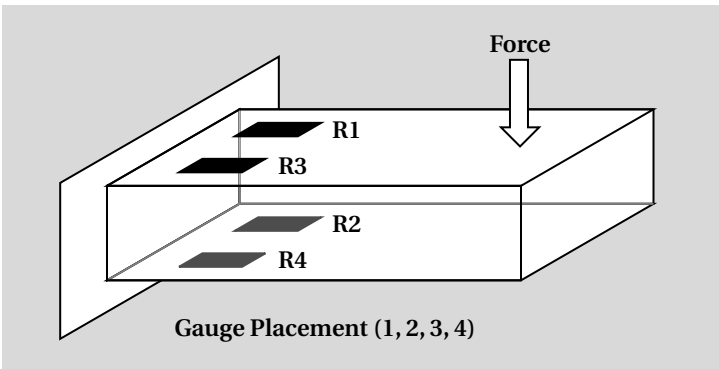

Figure 7-4. Strain gauge placement for a four-element bridge

Accurate measurement of strain gauges requires a low noise, regulated voltage source to eliminate unwanted variation in  $V_{OUT}$ . The current requirement can be calculated according to Ohm's Law as  $I = V_S/R$ , where  $R$  is the total resistance of the bridge. These current requirements are typically quite low; a  $120\Omega$  bridge operating from 5V would require 5/120 or about 42mA. Recommended maximums for the strain gauge supply voltage ( $V_S$ ) range from 1–2V up to 25V or more. The applied voltage should not exceed the strain gauge manufacturer's recommendations.

## 7.4 Gauge Factor

The term *gauge factor* (GF) describes the ratio of the change in resistance with respect to strain. The complete expression for GF is:

$$GF = \frac{\Delta R/R}{\Delta L/L} = \frac{\Delta R/R}{\epsilon}$$

A typical gauge factor is two; however, the strain gauge manufacturer should supply the actual gauge factor and tolerance for individual product samples. Ten microstrain applied to a gauge with a gauge factor of two results in a resistance change of 20 micro-ohms ( $20 \times 10^{-6}\Omega$ ). The maximum strain likely to be encountered with most metallic objects is about 5,000 microstrain, which, with  $GF = 2$ , corresponds to a change in resistance of 10,000 micro-ohms ( $0.01\Omega$ ). Therefore, measuring strain accurately requires instrumentation that can resolve at least  $1\mu\Omega$  or  $1\mu V$ .

## 7.5 Sources of Error

Like other types of resistive sensors, the accuracy of strain gauges can be affected by electrical noise, thermoelectric EMFs, and joule heating. Therefore, strain gauges should be installed using shielding where necessary and taking connector metals, supply voltage, and ambient temperature into consideration.

Note that quarter and half bridge configurations are more susceptible to non-linearity errors than a full bridge as the bridge moves out of balance, as well as to errors caused by the resistance of measurement leads. Using a full bridge will minimize or eliminate these error sources.

To minimize self-heating, the voltage used to power a strain gauge bridge should be only high enough to achieve the desired result, and should not exceed the manufacturer's recommendations. Note that a rated maximum supply voltage might only be permitted for applications where the test object can adequately sink heat from the gauge. Excitation can be applied only during measurements as a means of reducing self-heating.

Strain gauges are often accompanied by a reference temperature or temperature range for which the gauge's specifications are valid.

A full bridge strain gauge can tolerate temperature change with minimal effect on the bridge's basic accuracy, because all four legs of the bridge presumably have the same temperature characteristics and are affected equally. For quarter or half bridge configurations, temperature-dependent errors can be compounded by the possibility that bridge completion resistors are located some distance from the strain gauge, and that they have thermal characteristics that differ from the rest of the circuit. Therefore, it may be necessary to compensate for

temperature effects. This process requires measurement of gauge temperature, and application of temperature coefficient information supplied with the strain gauge.

In actual applications, temperature changes can result in dissimilar rates of expansion between the strain gauge and the test object. These dissimilar expansion rates appear as mechanical strain in the test object, even though the object has not been subjected to any distorting force. This “apparent strain” can be minimized by maintaining the test object and strain gauges at a consistent temperature, and by matching strain gauges to test objects according to thermal expansion characteristics. Strain gauge vendors frequently offer gauges matched to the thermal expansion properties of plastics, aluminum, steel alloys, and other common structural materials.

## 7.6 Operation

Unlike bridge-based measurements with resistive temperature sensors, strain gauge bridges are used in applications where the incremental change in resistance is of greater interest than the absolute output level of the bridge. Normally, bridge output vs. strain closely approximates a linear relationship. The output of a strain gauge is relatively small, up to a few thousand microstrain, because the bridge does not move very far out of balance, even with the test object loaded to maximum.

A variety of techniques exist for converting bridge behavior into strain. These range from bridge rebalancing to a simple reading of the voltage across the bridge. This direct reading method assumes a linear relationship between bridge output voltage ( $V_{OUT}$ ) and strain ( $\epsilon$ ). A bridge that is balanced under no load conditions is helpful in minimizing possible linearity errors.

The following paragraphs describe formulas for calculating basic strain measurements for a Wheatstone bridge, based on the supply voltage ( $V_S$ ), the bridge type, gauge factor (GF), and the bridge output voltage ( $V_{OUT}$ ). The formulas make use of an additional variable, voltage ratio ( $V_R$ ), which is calculated as follows:

$$V_R = \frac{V_{OUT (Strained)} - V_{OUT (Unstrained)}}{V_S}$$

### 7.6.1 Full Bridge Configuration

The full bridge provides several advantages over half and quarter bridges, including maximum sensitivity, fewest error components, greatest immunity to noise, and easier management of temperature effects. **Figure 7-5** shows the four strain gauge elements in a full bridge configuration. The following formulas can be used to calculate strain for the full bridge:

Where  $R_1$ ,  $R_2$ ,  $R_3$  and  $R_4$  measure normal strain:

$$\varepsilon = \frac{-V_R}{GF}$$

Where  $R_1$  and  $R_2$  measure Poisson's Strain, and  $R_3$  and  $R_4$  measure normal strain:

$$\varepsilon = \frac{-2V_R}{GF(\nu + 1)}$$

Where  $R_1$  and  $R_3$  measure Poisson's Strain, and  $R_2$  and  $R_4$  measure normal strain:

$$\varepsilon = \frac{-2V_R}{GF[(\nu + 1) - \nu(\nu - 1)]}$$

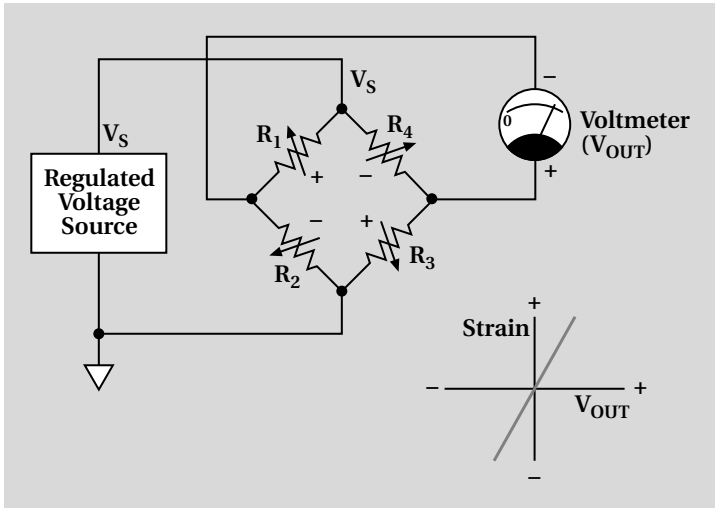

Figure 7-5. Strain gauge bridge with four strain gauge elements

## 7.6.2 Half Bridge Configuration

A half bridge uses two strain gauges mounted on a test member and two bridge completion resistors (**Figure 7-6**). Where the active strain gauge elements are some distance from the instrumentation, the resistance of lead wires ( $R_L$ ) must also be considered. Assuming that all wires leading to the remote bridge are the same length and gauge, then  $R_L$  should be the same value for all leads. Thus, the lead resistances in the bridge legs will cancel each other out, leaving the resistance in the (+) voltmeter lead as the only one of importance. Use of a high impedance voltmeter will minimize the effect of this resistance. The following equation applies to the half bridge and provides compensation for lead resistance:

Where  $R_3$  and  $R_4$  measure normal strain:

$$\epsilon = \frac{-2V_R}{GF} \times \left( 1 + \frac{R_L}{R_G} \right)$$

Where  $R_3$  measures Poisson's Strain and  $R_4$  measures normal strain:

$$\epsilon = \frac{-2V_R}{GF} \times \frac{-4V_R}{GF[(\nu + 1) - 2V_R(\nu - 1)]} \times \left( 1 + \frac{R_L}{R_G} \right)$$

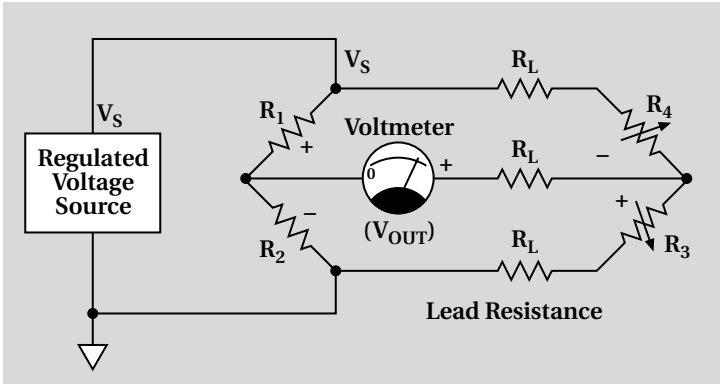

Figure 7-6. Half bridge strain gauge

$R_G$  is the resistance of one of the strain gauge elements and  $R_L$  is the lead resistance.

Note that wire gauge strongly influences the effect of lead resistance. Ten feet of 18 gauge wire ( $0.0066\Omega/\text{foot}$ ) and a  $120\Omega$  bridge results in the multiplier term  $(1 + R_L/R_G)$  equaling 1.0005, which shows an error of 0.05%. Therefore, the best method of reducing lead resistance effects is to use the shortest, heaviest gauge wire practical in the application. Refer to Appendix C for information on the diameter and resistance of various wire gauges.

### 7.6.3 Quarter Bridge Configuration

A quarter bridge (Figure 7-7) uses one strain gauge and three bridge completion resistors. Completion resistor  $R_3$  can be located with the instrumentation and other completion resistors or remotely with the strain gauge element. Remote location of  $R_3$  can minimize errors due to a temperature differential between  $R_3$  and  $R_4$ , but can present a problem with mounting the resistor.

As with the half bridge, the lead resistance ( $R_L$ ) must be considered. Figure 7-7 uses a three-wire measurement scheme that cancels lead resistance in the leads carrying excitation and ground to the remote gauge. The following equation applies to the quarter bridge, and pro-



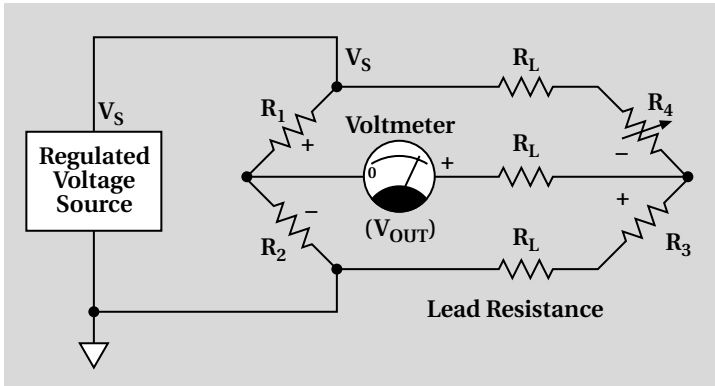

Figure 7-7. Quarter bridge strain gauge

vides compensation for resistance of the voltmeter lead. The same observations concerning wire gauge apply to the half bridge:

Use of one active strain gauge  $R_4$  precludes measurement of Poisson's Strain.

$$\varepsilon = \frac{-2V_R}{GF} \times \frac{-4V_R}{GF(2V_R + 1)} \times \left( 1 + \frac{R_L}{R_G} \right)$$

## 7.7 Strain Gauge Signal Conditioning

The output of a strain gauge is on the order of a few millivolts per volt of excitation, so the instrumentation used must be able to resolve microvolt signal levels (or micro-ohm levels if an ohmmeter is used for direct resistance readings). Therefore, all the standard techniques for low noise, sensitive measurements apply to strain gauges, including shielding, filtering, differential voltage measurement, and signal averaging. This signal conditioning should be available as part of the A/D input used to read the strain gauges. For remote installations, note that many manufacturers offer signal conditioning pre-amps that can be installed near the strain gauges to boost the signal level to 0–10V or 4–20mA output ranges. (The term *transmitter* is used in process industries for devices that convert input signals to isolated two-wire current loop outputs.)

## 7.8 Shunt Calibration

The normal procedure to verify the output of a strain gauge measurement system relative to some predetermined mechanical input or strain is called *shunt calibration*. Shunt calibration involves simulating strain gauge loading by connecting a known high resistance ( $R_1$ ) across one leg of the bridge ( $R_2$ ). The resulting resistance ( $R_T$ ) for that bridge leg can be calculated by:

$$R_T = \frac{R_1 R_2}{R_1 + R_2}$$

The output of the bridge can then be measured and compared to the expected voltage value. It can also be used to correct span errors in the entire measurement path or to verify general operation of the test setup.

Caution: The shunt calibration is a convenient way to simulate strain electrically. However, it does **not** check the mechanical function of the sensor, so it may not detect errors caused by cracks, deformation, or other mechanical problems. To check for these kinds of problems, apply a known weight or other suitable physical stimulus periodically to verify that the sensor responds appropriately.

## 7.9 Load Cells, Pressure Sensors, and Flow Sensors

A variety of physical phenomena can be measured with strain gauge-based transducers coupled with specialized mechanical elements. These phenomena include load, gas or liquid pressure, and flow rate, among others.

A load cell is simply a packaged strain gauge designed to measure force under different load conditions. A typical load cell body is machined from metal to provide a rigid but compressible structure. The load cell body is usually designed with mounting holes or other fittings to allow the unit to be mounted permanently on a supporting structure.

Typical transducers for pressure sensing are electromechanical devices that combine a sensor with mechanical elements such as a diaphragm, piston, or bellows. The mechanism is designed to respond to a pressure differential and expand against a spring, which determines the range of the sensor. The pressure sensing element also actuates a strain or positional sensor that produces an electrical output that can be read by an instrument.

Flow can be measured in a variety of ways, most of which are indirect measurements that depend on the material's viscosity, conductance, or other properties. One very common way to infer flow is to measure the material's pressure drop when passing through an orifice, using two pressure sensors. The equations for converting this "delta-P" to flow are beyond the scope of this handbook, but are discussed extensively in other literature.

Several general rules apply to the transducers described in this section:

1. These transducers are ready-to-use, self-contained devices fitted with wire leads for excitation input and signal output. Packaging can include electrical quick disconnects, mounting holes, threads, pressure fittings, or other features to simplify attachment and use.

2. These transducers are designed for process control or other commercial applications, as opposed to traditional strain gauges that are used for experimentation or research.
3. Transducers may be based on traditional resistive strain gauges or on other sensor technologies. They must be powered from an external excitation voltage specified by the manufacturer. The output is frequently a low-level signal, so it often requires amplification and signal conditioning for best results. External drift compensation, calibration, and zero adjustment may be required to provide accurate, long-term results.
4. Sensing elements are fully integrated into the transducer. They are frequently sealed from the environment and inaccessible to the user.

## 7.10 Acceleration, Shock, and Vibration

Acceleration, shock, and vibration are important parameters in mechanical applications, including automotive, aerospace, product packaging, seismology, navigation and guidance systems, motion detection, and machine maintenance. These parameters can all be measured using a sensor known as an *accelerometer*.

### 7.10.1 Acceleration

Acceleration is the rate of change of velocity that a mass undergoes when it is subjected to a force. It is defined by the formula:

$$\text{Force} = \text{mass} \times \text{acceleration}$$

Assuming that mass and force remain the same, then acceleration is constant, meaning that an object's velocity will continue to change at a uniform rate. Acceleration is expressed as distance per time squared, with meters/sec<sup>2</sup> and feet/sec<sup>2</sup> being common units. Earth's gravity exerts a force of 9.8m/sec<sup>2</sup>, or 32ft/sec<sup>2</sup>; this amount of acceleration is often referred to as 1g (*g* for *gravity*). Sensors designed to measure acceleration can measure values ranging from millionths of g ( $\mu\text{g}$ ) to hundreds of g or more. They are frequently designed to withstand overloads of thousands of g without damage.

Note that velocity is a vector quantity and consists of components for speed and direction. Therefore, an object undergoes acceleration when its speed, direction, or both change. Furthermore, the direction of the acceleration can be multi-dimensional, requiring a multi-axis accelerometer for complete measurement. Accelerometer mounting can be critical for achieving satisfactory results; a misalignment of only a few degrees can have profound effects on the final result.

### 7.10.2 Shock

Shock is a special case of linear acceleration in which the acceleration (or deceleration) time approaches zero. In the real world, the time cannot equal zero, but it can equal a very small fraction of a second. The result of a large change in velocity over a short time can produce an acceleration of hundreds of g or more.

For shock studies, the measurement range of the accelerometer must be able to handle the acceleration expected in the specific shock situation. This value can be calculated by dividing the change in velocity by the time interval:

$$a = \frac{\Delta V}{\Delta t}$$

For example, an object traveling at 100m/sec that strikes a surface and stops in 0.5 seconds (a relatively mild shock, by some standards) would experience a deceleration of 200m/sec<sup>2</sup>. The force of gravity is 9.8m/sec<sup>2</sup>, so this deceleration corresponds to approximately 20g. For purposes of comparison, this shock might be fatal to a human, but some computer hard drives are specified to withstand a 30g shock while operating, and up to 300g while unpowered.

### 7.10.3 Vibration

Vibration is a continuing change in the position of a body, typically occurring in a cyclic pattern with a constant or near-constant period. Vibration is a common characteristic of machines; it is of interest in manufacturing because its measurement can provide an indication of the health of machinery. Periodic monitoring and analysis of vibration levels can reveal specific problems, such as worn bearings, loose fasteners, or out-of-balance rotating components, before they become severe enough to be noticed or to cause complete failure. Vibration is a cyclic changing of position, so it can be detected by using an accelerometer.

### 7.10.4 Resonance and “Q”

Accelerometers are based on a mechanical operating principle, so they are governed by the physics of vibrating bodies, notably, the characteristics of resonance and “Q.” All bodies possess a resonant frequency at which the body will vibrate when excited mechanically. Generally, more massive bodies have a lower resonant frequency. The “Q” parameter describes the degree to which the effect of excitation energy is amplified by a body as the frequency of excitation nears the body’s resonant frequency. This amplification is a process of the body storing the energy and re-emitting it in phase with the driving energy. The higher the Q factor, the more pronounced this amplification effect will be.

When the frequency of a vibrating body nears the sensor's resonant frequency, the sensor begins to absorb energy. This drives the sensor into mechanical oscillation, and the measurement becomes progressively less accurate. In extreme cases, the sensor itself can go into uncontrolled oscillation and be damaged.

Every physical sensor's response consists of two components: a forced response in reaction to an input signal (the useful output for measuring that signal), and a natural response, which are attributable to the sensor's own resonant frequency and  $Q$ . Resonance and  $Q$  are properties of the sensor itself, so they do not help characterize the input signal. As far as the measurement is concerned, they are noise. Thus, it's important to consider resonance and  $Q$  to choose an accelerometer that will provide accurate results in a given application. The frequency of vibration to be studied should be well below the resonant frequency of the sensor; some sensors will be suitable only for steady-state acceleration or low frequency vibration measurements. Generally, sensors with a low mechanical  $Q$  (e.g.,  $Q=1$ ) can be used to measure vibration at frequencies up to approximately one-half the sensor's resonant frequency before error becomes objectionable. High- $Q$  sensors (e.g.,  $Q=10,000$  or more) may be used for vibration frequencies up to about one-third the sensor's resonant frequency. These figures are approximations; consult the manufacturer's data for the specific accelerometer to be used.

### 7.10.5 Accelerometer Types

An accelerometer measures acceleration by detecting a change in the speed and/or direction of a body. The operating principle of the accelerometer couples a mass to a sensor that can generate an electrical signal. The sensor produces an output signal that is proportional to the acceleration.

Accelerometers exist in a variety of forms, some of which are listed in **Table 7-2**. There are also accelerometers that use inductive, capacitive, Hall effect, or other varieties of basic sensing technology to detect acceleration. Each offers specific advantages in the form of output, frequency response, etc.

Another important consideration with accelerometers is that attaching the sensor to the test structure alters the mass of the structure, so it can affect its frequency of vibration significantly. For an accurate assessment of vibration, this loading effect should be minimized by using a low mass sensor, which is placed to provide maximum signal while minimizing loading effects. A rule of thumb for the accelerometer's mass is that it should not exceed one-tenth the mass of the structure under test.

**Table 7-2. Selected accelerometer types**

<b>TYPE</b>	<b>FEATURES</b>
Strain Gauge/Mass (or "strain") Accelerometer	Combines a traditional strain gauge type of sensor with an inertial mass. Suitable for steady-state (non-cyclic) acceleration measurements and low frequency vibration studies.
Piezoelectric Accelerometer	Uses a piezoelectric (quartz) element coupled to an inertial mass to generate a voltage or charge in response to acceleration. Suitable for vibration studies at frequencies of a few Hertz and higher. Suitable for high shock environments. Not recommended for steady-state measurements. Very high resonant frequency permits measuring vibration of 30–40kHz or more.
Spring-resistive Accelerometer	Uses a spring/mass mechanism that operates the wiper of a potentiometer in response to acceleration. Simple operating principle. Suitable for steady-state and low frequency vibration measurements (~7 to 10Hz or less).

### 7.10.5.1 Strain Gauge Accelerometer

The strain accelerometer uses a strain gauge in conjunction with a cantilevered mass. When the sensor is subjected to an accelerating force, the mass's inertia causes a distortion of the cantilever, and the strain gauge measures the resulting strain. Obviously, the positioning of the sensor relative to the accelerating force is important in detecting the acceleration and generating the highest possible output signal.

Circuits for interfacing to strain gauge accelerometers are similar to those used for standard strain gauges. A Wheatstone bridge configuration may be used, along with appropriate signal conditioning. However, the possibility that the gauge will be used to measure vibration makes it important to consider the frequency of the signal. Where vibration is measured, a sampling rate and signal conditioning chosen must capture the desired information while avoiding aliasing. If the goal is to reconstruct a waveform in great detail, then a sampling rate many times the highest frequency component of the vibration will be required.

The resonant frequency of an undamped strain gauge accelerometer is relatively low (typically, a few kilohertz), while its Q is relatively high, making this type of sensor better suited to applications with frequencies of DC to ~1000Hz. Some are suitable for frequencies of only a few hertz. A damping material, such as oil, is sometimes incorporated into the design of an accelerometer to lower the mechanical Q of the sensor and increase the frequency range over which it can be used.

### 7.10.5.2 *Piezoelectric Accelerometer*

The piezoelectric effect is well known; it is used in many types of devices that produce an output voltage in response to a mechanical force. A compressive or shear force applied to a piezoelectric crystal (typically, quartz) produces a charge within the crystal that is proportional to the force. The crystal acts like a capacitor to store the charge. The output impedance of a piezo crystal is very high, so specialized voltage or charge amplifiers are needed to measure the unconditioned output of the crystal. Special attention must be given to the length and properties of cabling between the sensor and amplifier.

A more common variation of piezo-based accelerometers uses built-in amplification and signal-conditioning circuitry to provide a low impedance output signal. The sensitivity of this type of sensor is specified by the manufacturer; its output can be read with conventional high speed voltage input on a data acquisition board. These conditioned sensors offer high noise immunity and simpler requirements for cabling between the sensor and measurement instrument.

The piezoelectric accelerometer is characteristically a low Q device with high resonant frequency. Piezoelectric accelerometers with resonant frequencies as high as 120kHz are available, providing a usable frequency range from a few hertz to 35–40kHz. Piezoelectric accelerometers are not recommended for steady-state acceleration measurements.

### 7.10.5.3 *Spring-Resistive Accelerometer*

The spring-resistive accelerometer is a simple design that is similar in concept to a spring scale with a suspended mass. Acceleration causes the mass to exert a force on the spring, which causes the spring to expand or contract. If this linear motion is coupled to a potentiometer wiper, the changing resistance value will provide an electrical signal indicating acceleration.

## 7.10.6 Instrumentation Requirements

Acceleration, vibration, and shock present a very wide dynamic range of physical phenomena to be measured in terms of magnitude, duration, sensor characteristics, and final information the measurement must provide. The goal of any of these measurements might be simply to determine maximum acceleration or it might be as complex as reconstructing a profile of velocity with respect to time.

Assuming that a suitable accelerometer has been chosen for the application, the primary hardware concerns for reading the accelerometer become sampling speed and signal conditioning. The sampling rate of the analog input board must be sufficient to capture the desired phenomenon, and also satisfy the Nyquist rule: the sampling rate must be at least twice the highest frequency component of the signal to be

captured. For a vibration study, in particular, the test subject may vibrate at a fundamental frequency plus selected harmonics of the frequency. These harmonics are multiples of the fundamental, and can be useful for identifying particular problems with a machine.

Conversely, it is also important to use anti-aliasing filters to remove high frequency components that are more than one-half the sampling rate in order to eliminate false characteristics in the reconstructed waveform. Obviously, where greater detail is required in a vibration measurement, it may be necessary to sample the signal at many times the highest frequency component to reconstruct the waveform accurately. Depending on the type of signal and distance between the sensor and A/D input, additional signal conditioning in the form of amplification and impedance conversion can be required.

Given that the maximum frequency of vibration to be measured with an accelerometer might be on the order of 30–40kHz and probably 5–10kHz in more typical applications, an A/D board with a minimum 100kHz sampling capability would be a good choice.

Signal levels can vary from a few millivolts for strain gauge accelerometers to several volts for sensors using integrated signal conditioning. Some integrated sensors may output a current (4–20mA) rather than a voltage. Therefore, a suitable A/D board for use with accelerometers should have sufficient gain and noise performance to provide readings with the necessary resolution.





---

SECTION 8

**Related Topics  
of Interest**

---

## 8.1 Current Measurements

Electrical currents can be measured with data acquisition systems, but the method selected will depend on the current level and number of required channels. An important characteristic of a current loop is that any lead resistance in the circuit does not affect current flow as long as the source can supply the required voltage. That makes current loops ideal where there's an appreciable distance (i.e., >2m) between the signal source and the instrumentation.

Measuring current is necessary under two sets of circumstances. The first case is where the sensor or signal source outputs a current, rather than a voltage. In these circumstances, the current is an indicator of some other phenomenon to be measured, so it must be converted into appropriate engineering units. A pressure transducer with 4–20mA output is one example of this situation. A reading of 4mA corresponds to no pressure (zero pounds per square inch), while 20mA is the transducer's full-scale output in pounds per square inch.

The second application of current measurement is where the actual current reading is the parameter of interest, such as tracking the load current drawn by a device over time. Here, it's important to remember that the current may be relatively high, which requires extra care in selecting a dropping resistor.

### 8.1.1 Voltage Burden

The concept of “voltage burden” is important to achieving the best results in a current measurement setup. Voltage burden is defined as the voltage drop across the input of an ammeter when it is inserted into a circuit. In **Figure 8-1**, the dropping resistor (R) and A/D voltage input constitute an ammeter, and the current flow can be calculated from the voltage drop across a resistor.

The resistor value will normally be selected to provide a voltage drop corresponding to the A/D board's input range when the maximum anticipated current flows through the resistor. For example, a 20mA current produces a 10V drop across a 500Ω resistor. A 490Ω resistor will provide some safety margin in the measurement without a significant loss of resolution. Note that the sensor or current source must be capable of a minimum 10–11V output to achieve the full voltage drop across the resistor. If the circuit is powered only by 6V, the circuit can not drive more than 12mA through the resistor.

The power dissipated by the resistor must also be considered. For a 20mA current through a 500Ω resistor, dissipation (P) can be calculated as:

$$P = I^2 \times R = (0.02)^2 \times 500 = 0.2W$$

This application could be handled with a 0.25 or 0.5 watt resistor.

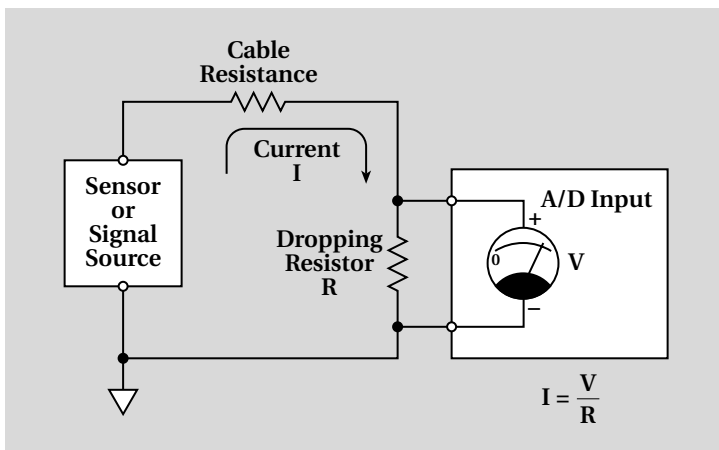

Figure 8-1. Current measurement using a dropping resistor

In a case where a higher current—2A, for example—needs to be measured, the voltage drop across a 500Ω resistor would be 1000V, with a power dissipation of 2000W. Clearly, a lower resistance value is required. A 5Ω resistor would produce a voltage drop of 10V, but the resistor would still dissipate 20W. A resistance value of 1Ω, or even 0.5Ω, would produce an easily measurable signal and result in much lower power dissipation and voltage burden.

### 8.1.2 DMM vs. A/D Board for Current Measurements

A programmable DMM or external data acquisition system based on DMM architecture (such as Keithley's Model 2700 or 2750) can measure current directly. Making connections to the signal source is straightforward, and such meters are designed to impose a minimal voltage burden on the signal. They are also suitable for measuring currents up to several amperes. The advantage of this method is that such meters have built-in signal conditioning circuitry and can provide high channel counts (up to 200) at a low cost per channel.

A typical plug-in A/D card offers many voltage input channels, and some include on-board sockets that allow dropping resistors to be mounted on the board. The advantage of using an A/D board for current measurements is that the A/D board will typically run significantly faster than a DMM. However, currents generally have fewer high frequency components, so speed may not be a primary concern. The chief limitation of current measurement with an A/D card is that there is no simple way to change the dropping resistor under program control in order to change ranges.

## 8.2 Connection Theory

Most electronic measurements, including those typical of data acquisition, require an electrical connection between the data acquisition hardware and signal source. The validity of these measurements depends largely on how well cables and connectors are matched to the signals, and how carefully the measurement setup is constructed and routed.

Data acquisition applications usually deal with DC signals in the range of 1mV to 10V, but stand-alone instruments can be used to measure signals far above and below this range. While many concerns common to low level or high level measurements, such as triboelectric effects, thermoelectric effects, and insulation properties, are less of an issue in data acquisition applications, they are still critical concerns in other measurement scenarios. Electromagnetic noise, cable length, and cable capacitance can affect the quality of any type of measurement.

### 8.2.1 Cable Type

A particular type of wire or cable's suitability for data acquisition depends largely on the nature of the signal and the test environment. When evaluating a cable for this application, consider these issues:

- **How much electrical noise exists in the environment?** Noise can be defined as any undesirable signal that is impressed upon a signal of interest. Sources of electromagnetic noise include AC power lines, motors and generators, transformers, fluorescent lights, CRT displays, computers, radio transmitters, etc. Depending on the nature of the signal and the noise, it may not be possible to separate them once the signal has been acquired
- **What is the distance between the signal and data acquisition input?** Wire exhibits some electrical resistance, which depends on the composition, length, and gauge of the wire. Resistance increases with increasing wire length and with decreasing wire diameter. This resistance becomes a part of the analog input circuit as shown in **Figure 8-2**. For most voltage-based analog measurements, the source resistance of the signal will be low (i.e., less than 100 $\Omega$ ), while the input resistance of the analog channel will be on the order of 10–100M $\Omega$  or higher. Therefore, a few ohms resistance in interconnect cabling will not appreciably affect measurements. However, a high cable resistance in conjunction with low A/D input resistance can result in a significant voltage drop through the interconnect wiring. For data on the resistances of common wire gauges, refer to Appendix C.
- **Is the data acquisition channel a single-ended or differential input?** Single-ended signals, i.e., those referenced to ground, can be transmitted with two wires or with a shielded cable where

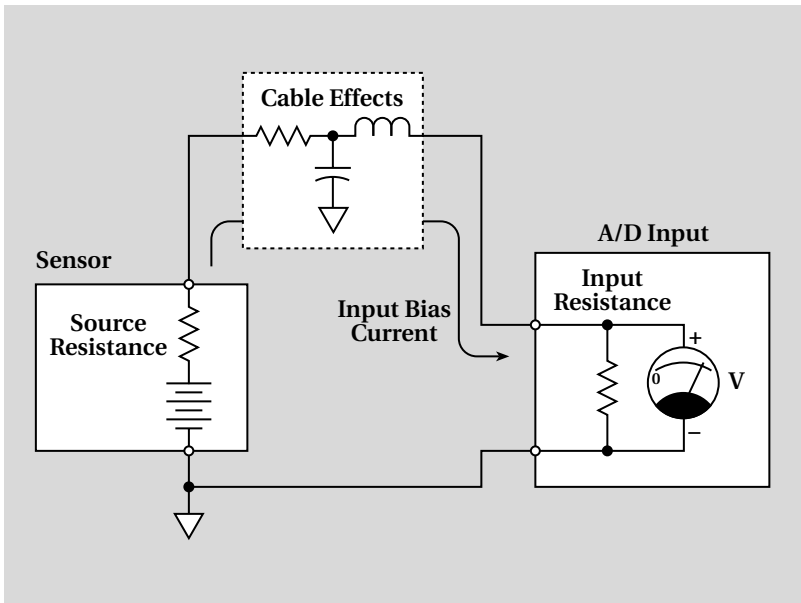

Figure 8-2. Circuit for voltage measurement

the shield is tied to ground. For differential signals, at least two wires are needed to transmit the signal, which consists of a signal high and a signal low, neither of which is referenced to ground. Two individual conductors will work, but a twisted pair or shielded twisted pair provides greater noise immunity.

## 8.2.2 Conductors

The conductors used in shielded or unshielded cable can be solid or stranded wire. Solid wire results in minimum signal attenuation, but stranded conductors provide more flexibility. Often, conductors are plated with silver or tinned with solder.

## 8.2.3 Shielding

Shielding is employed to reduce the amount of noise picked up by signal leads, but shielding can also be helpful in reducing signal radiation from conductors carrying high frequency signals. Shielding can be constructed with different types of wire braid or a combination of wire braid and foil. Multi-layer or multi-braid shields are more effective than single layer shields in attenuating signal pickup or radiation, but can also make cables stiffer and more difficult to position.

Consider these tips when selecting shielded cable:

- Depending on frequency, shielding may not attenuate noise completely. Higher frequency signals are more difficult to attenuate than lower frequency signals.
- Simple spiral wire wrap is the least effective type of shielding.
- Tight braiding, double braiding, or braiding plus foil offer more effective shielding.
- Caustic atmospheres, moisture, etc. can change the effectiveness of shielding. In some cases, these contaminants can leach into a cable and degrade the shielding far beneath the outer insulating jacket.

**Table 8-1** lists typical wire and cable types that may be encountered in data acquisition. These range from single, unshielded wires to various types of shielded single or multi-conductor cables. Cable vendors normally supply specifications concerning the shielding properties of their cable products.

*Table 8-1. Characteristics of hookup wire and cables*

<b>TYPE</b>	<b>ADVANTAGES</b>	<b>DISADVANTAGES</b>
Single Conductor	Inexpensive. Easy to connect.	Susceptible to noise pickup.
Twisted pair	Suitable for differential signals. Provides some protection against noise pickup.	Marginally more expensive than single conductor.
Single Conductor with Shield (Coax)	Better protection against noise pickup.	Higher cost. Connection to equipment more difficult.
Shielded Twisted Pair or Shielded Multi-conductor Cabling	Best for differential signals in noisy environments.	Higher cost. Connection to equipment more difficult.
Ribbon Cable	Convenient for multi-conductor hookup to data acquisition cards. Available as flat ribbon cable or a series of twisted pairs.	Can be more susceptible to noise pickup and crosstalk. May not be suitable for higher speed signals. More difficult to attach connectors. Insulation displacement connectors may have lower insulation ratings.

## 8.2.4 Cable Capacitance

A typical signal behaves like a voltage source in series with a resistance. Similarly, an analog instrument input resembles a meter with infinite input resistance in parallel with the instrument's actual input resistance. During a measurement, the instrument input absorbs a small bias current that the source must be able to generate. The interconnect cabling is an essential part of this circuit, and can introduce resistance, capacitance, and inductive effects that depend on length, gauge, composition, routing, and environment. **Figure 8-2** shows a dashed box around a portion of the signal path that represents the sum of these effects.

For high speed, rapidly changing signals, circuit inductance and capacitance can be serious obstacles to measurement speed, even if signal and instrument impedances are properly matched. Generally, high impedance signals take longer to stabilize at the instrument because the signal's limited current requires more time to charge cable capacitance.





---

SECTION 9

Application  
Examples

---

## 9.1 Introduction

This section provides examples of real-world applications that employ data acquisition products to monitor or control industrial processes. These examples are intended simply to demonstrate what is possible, rather than providing details such as programming examples and wiring diagrams. For in-depth information, contact Keithley Instruments' Applications Engineering department.

## 9.2 OEM/Factory Automation and Data Acquisition

The primary purpose of implementing data acquisition hardware in OEM and factory automation systems is to capture process-specific parameters, which are evaluated in a control processor. The control processor generates signals to maintain or adjust the process based on these inputs. Additionally, the acquired data can be used to provide operator indications and feedback.

The types of transducers typically interfaced to data acquisition systems include thermocouples, resistive temperature devices (RTDs), thermistors, pressure sensors, strain gauges, and flow sensors. The outputs from these transducers are generally unipolar or bipolar voltages from 5V to 10V or a current in the range of 4–20mA. These outputs can be a linear representation of the input to the transducer, such as flow or pressure, or they can be a non-linear representation, such as the response of a thermocouple to temperature.

Typically, the system's control outputs are used to change the state of some external device:

- Actuating a relay
- Increasing or decreasing flow or pressure by driving a solenoid valve
- Repositioning an object through the use of stepper motors
- Regulating the temperature of an environment

Primarily, these output signals are a combination of digital TTL levels (0 to 5VDC) and analog levels (-10V to +10V, 4–20mA current, or 120–220VAC). High voltage outputs will most likely be controlled using a digital output that drives a relay or optically isolated accessory. However, boards are available that can supply these signal levels directly.

The devices used to measure and generate these voltages and currents vary according to computer platform, and can include ISA, EISA, and PCI plug-in hardware, IEEE-488 bus-based hardware, VXI/VME, PLC, or compact PCI. These devices seem to be evolving into distributed I/O components connected via Ethernet or high speed serial and parallel links. The fundamental purpose behind each of these platform options is to convert real-world analog signals into digital signals via an analog-to-digital converter or A/D. These digital signals can then be

transferred to, and manipulated by, a computer. The control outputs are then converted from digital signals to analog (D/A) and applied to the external devices.

### 9.2.1 Design Considerations

It would be nearly impossible to characterize a “typical” OEM or factory automation application. Systems that can measure and control almost every parameter in a process have been implemented throughout nearly every industry. The nature and physical environment of an application will help determine its basic system design requirements.

For example, consider what would be involved in an application designed to control a 2000-ton hydraulic press and its associated robotic parts-handling equipment. In this situation, a high degree of determinism (i.e., precisely known and controlled response times to stimuli) is required, along with control signals and transducers that can function in electrically noisy environments. If the system builder were to implement a solution based on a PC platform, plug-in data acquisition boards, TTL inputs and outputs (I/O), and the Windows® 98 operating system, its likelihood of success would be questionable. The system requirements listed above would make a system based on Programmable Logic Controllers (PLCs) with 115VAC control I/O much more appropriate for this application. PLC processors are designed to operate with very deterministic control loops, and the 115VAC control signals are inherently immune to noisy environments.

Next, consider an application that involves measuring a number of thermocouple inputs from a process every 10 seconds, generating outputs to maintain a specific temperature, routing unit-under-test (UUT) signals, and measuring DC test parameters. In this case, a PC-based system with a GPIB interface, a Keithley Model 2700 Multimeter/Data Acquisition System would function well. Given that temperature is a slow-moving parameter by nature, temperature control can easily be maintained through PC-based I/O and control software. One measurement per second is typically sufficient. The time-critical UUT switching and measurements can be supported through the deterministic control provided by the Model 2700.

To build such systems successfully, the designer is responsible for determining the following requirements:

- Critical process parameters
- Measurement of process parameters
- Generation of control algorithms
- Generation of control signals

## 9.2.2 Measurement Integrity

It is not unusual to obtain significantly different test results from an automated test system than from a manual system that uses the same instrumentation. In other words, during the system design phase, an engineer may obtain perfectly acceptable test results from a manual test sequence on a bench-top system. However, the test results are significantly different once this system is transferred to the test rack, where signal switching and routing are under computer control and additional fixturing and longer signal paths are involved. What's going wrong?

In data acquisition and control systems, signal integrity depends on many factors unrelated to the actual measurement device. The measurement device might be an 8½-digit multimeter capable of nanovolt resolution. If the system switching and interconnects introduce many microvolts of thermal offset, the result will contain these errors as well. Furthermore, if the signal from a D/A board is transmitted through many feet of cable and switching, the resulting signal at the UUT may not be the value that was programmed.

So what are the primary areas of concern when trying to maintain signal integrity? A variety of factors can contribute to measurement error, including:

- Thermal offsets
- EMI/RFI
- Grounding
- Cable lengths/cable routing/switch speed
- A/D input configuration

Thermal offsets are generated where two dissimilar metals are joined. This junction can be at a screw terminal panel, quick disconnect panel, or even at relay contacts. When a system contains multiple connections of this type, each at a different temperature, significant measurement errors can be introduced. Errors of this type can often be ignored if the signal of interest is a relatively high level voltage, such as 10V. However, if the source signal level is in the millivolt or microvolt range, these offsets may introduce unacceptable levels of error.

System switching speeds can also introduce errors, depending on the length and type of cables and interconnects being used. Even if a switch can actuate in five milliseconds, it doesn't necessarily follow that the signal is ready to be measured in that time. The actual time constant of the signal path can be computed and compared to the manufacturer's specifications. This information must be considered when programming measurement times. The actuation time of the switching components may only be a few milliseconds. However, if the time constant of the entire path is 100 milliseconds, a delay (typically

equal to several time constants) must be programmed to occur between the switch closure and the measurement.

The effects generated from ground loops can also contribute to system measurement errors. The voltage potential between widely separated ground terminals within a system can be significant, and can generate a current that flows through the measurement ground system. One proven approach for reducing the effects of ground loops is to ground all equipment at a single point, and use isolated instruments and sources when possible.

The input configuration of programmable A/D hardware can have a significant effect on the acquired data. With some equipment, the user can choose single-ended or differential inputs. Generally speaking, single-ended inputs perform well in a low noise environment and when the signal levels are high ( $>1.0V$ ). Differential inputs have greater immunity to noise than single-ended ones, and should be selected when measuring low-level signals.

Interference from EMI/RFI sources can also contribute to system measurement error. Shielded cabling can be utilized to reduce the effect of EMI/RFI radiation both internal and external to the system. A wide variety of commercially available cabinets and enclosures incorporate extensive shielding.

### **9.3 Semiconductor CVD Application**

The continuing demand for semiconductor devices that combine increased density and higher speed has generated the need for increasingly complex manufacturing equipment to produce these devices. Chemical Vapor Deposition (CVD), the process of using a controlled chemical reaction to deposit layers on wafers, is widely used throughout the industry today.

A typical CVD system contains a reaction chamber, gas inlets, gas outlets, a heater, an exhaust system, and a substrate loading and unloading assembly. Systems can operate at or below atmospheric pressure and employ temperatures greater than  $300^{\circ}C$ . Clearly, if the system is to function properly, many parameters must be measured and evaluated, and control signals must be generated. These parameters include temperature, pressure, gas flow rate, and deposition time.

An industrial PC with a passive backplane configuration was selected for this application. It houses the processor card, as well as plug-in boards that perform the digital I/O, analog I/O, and counter/timer functions. The Model KPCI-3108 and KPCI-3130 boards are ideal for this application. Typically, the processor runs a real-time operating system, permitting deterministic response to process data.

Multiple thermocouples mounted beneath the wafer monitor the temperature within the chamber. The thermocouple cabling is routed

through a hermetically sealed interface and connected to a terminal block assembly with a cold junction reference. The millivolt-level thermocouple signals are measured by the KPCI-3108 board and then converted to temperature, evaluated, and the heater outputs adjusted based on the control algorithm. The heater control signals are digital outputs that control relays that isolate the TTL signals from the high voltage heater supply. **Figure 9-1** illustrates this application.

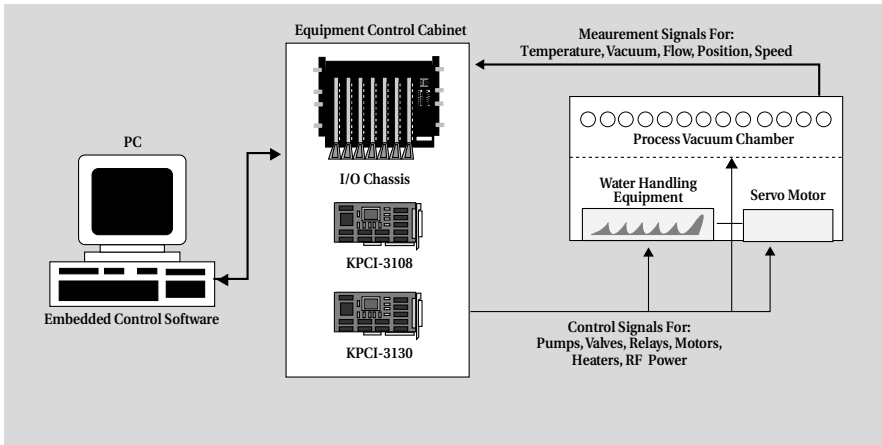

*Figure 9-1. Semiconductor fabrication equipment control*

System pressure and vacuum levels are measured by the KPCI-3108 via pressure transducers, which may provide either amplified or millivolt signal levels. Unlike thermocouples, pressure transducers typically operate linearly, based on the full-scale rating of the device. The gas flow through the inlet is monitored with a flow transducer that also exhibits linear characteristics based on the full-scale ratings. These signals are routed to the A/D hardware for conversion to flow rate and pressure readings. Consider the environment in the chamber when choosing transducers to ensure reliable operation

The operation of vacuum pumps and valves is controlled with digital output hardware. The digital input and output signals, which may be exposed to hazardous voltages and spikes, are isolated through relays or optical isolation. Signal conditioning and isolation are accomplished with industry-standard solid-state I/O modules. The KPCI-3130 analog output board generates discrete and variable control voltages for devices such as motors, and also for device excitation.

## 9.4 Process Monitoring in a Nuclear Power Plant

Process monitoring is a crucial application for many manufacturers because poorly controlled processes can produce defective products

and waste resources. A PC-based process/machine monitoring system provides an ideal solution for this application. It can collect data for analysis by statistical process control applications to ensure the manufacturing process is operating within specifications and in compliance with applicable governmental regulations.

PC-based systems are used widely by discrete, process, and batch manufacturers because they offer a low cost solution. For highly regulated industries, such as nuclear power plants, PC-based systems offer the added benefit of easy integration with existing processes and equipment without disturbing or modifying established control systems.

The challenge one nuclear power utility faced was the need to follow equipment manufacturers' preventive maintenance specifications strictly, as required by the Nuclear Regulatory Commission (NRC). The company also wanted the monitoring system to provide information in sufficient detail to allow engineers to detect and predict diesel generator abnormalities before the equipment experienced any damage. The parameters to be monitored included temperature, pressure, flow, and stress.

The power company wanted a system that was easy to use and versatile, so operators could acquire and analyze information gathered from diesel generators located throughout the facility. Finally, the company needed a low cost, turnkey solution.

The solution to this application was a networked system using a Keithley KPCI-1802HC plug-in data acquisition board in a PC (**Figure 9-2**). The KPCI-1802HC is a multifunction PCI board with 32 differential or 64 single-ended inputs, and two analog outputs. Analog inputs feature gains of 1, 2, 4, and 8. Any single channel can be sampled at any gain at up to 333ksamples/second, while multiple channels can be sampled at aggregate rates up to 312.5ksamples/second.

The system used an industrial PC, a dual redundant power supply, a network interface board, and Keithley's KPCI-1802HC data acquisition boards, all of which were integrated in a purged and cooled industrial enclosure. Each signal input to the monitoring system was continuously logged by the remotely located data acquisition PC, then transferred automatically over the plant LAN to a system manager PC.

The system tracked equipment performance automatically and generated the summary reports needed to satisfy the OEMs' and the NRC's requirements. While the past practice had been to generate reports from operator readings taken every 30 minutes, the new reports could be based on up-to-the-minute information compiled from millions of samples. The reports were much more accurate, and allowed plant personnel to capture and analyze any unexpected transients.

Today, the system monitors the diesel generators continuously year-round and captures all the data from every run. An added advantage of this system architecture is that since the system uses standard,



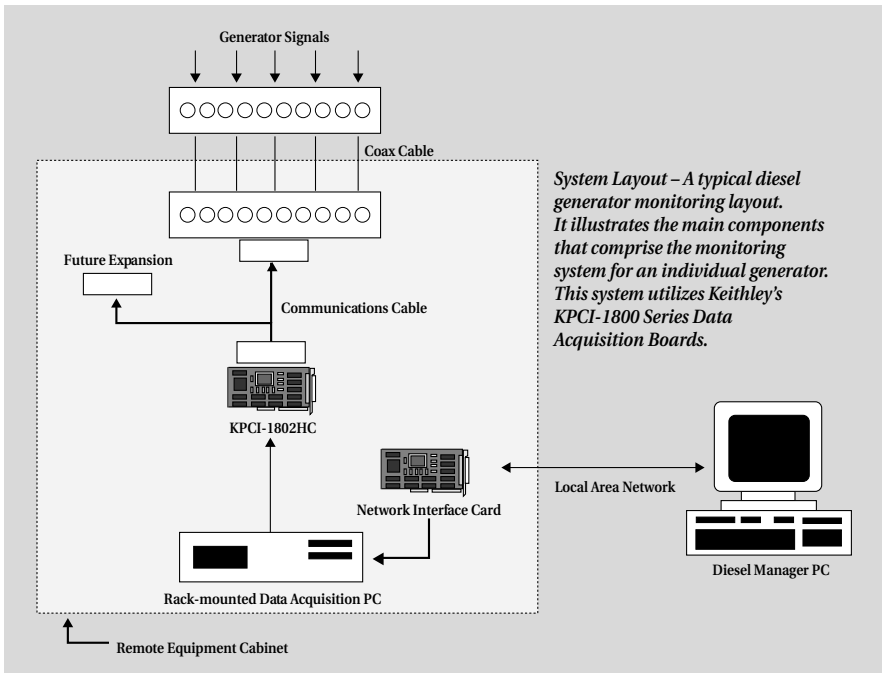

**Figure 9-2. Diesel monitoring in a nuclear power plant**

off-the-shelf products, such as Keithley data acquisition boards, it can be readily expanded incorporate new capabilities.

## 9.5 Tensile Test Stand Application

The increased use of rubber-based products across many industries has created the need for detailed characterization of these products prior to fabrication. This characterization process can include tensile, adhesion, tear, and compression testing.

In this application, a sample is placed in a test chamber, where the required environmental conditions are applied. A KCPI-3104 12-bit A/D board is used to measure process parameters from thermocouples (temperature), pressure transducers, and strain gauges. The application program converts the millivolt signals from the thermocouples into temperature readings. Strain and pressure inputs are processed in a similar manner, based on the functional specifications of the transducer. The application program evaluates these inputs, and uses a control algorithm to adjust the system temperature and force parameters.

System control outputs are generated using the KPCI-3104 board's digital outputs. Some applications also implement variable motor con-

trol with the board's analog output features. The input and output signals are optically isolated using industry-standard solid-state I/O modules. These modules can also be used to condition input and output signals to usable levels.

## 9.6 Burn-In and Stress Testing of Electronic Devices

The rapid growth of the telecommunications, desktop computing, and network server markets has created a burgeoning demand for switching power supplies and DC-to-DC converters. While these power supplies are relatively inexpensive, careful production testing is required to maintain product quality.

Highly Accelerated Life Testing (HALT) and Highly Accelerated Stress Screening (HASS) are common production “burn-in” procedures for switching power supplies designed for computers and file servers. Extended environmental testing is performed to ensure the product will continue to function properly over its entire service life. It is not uncommon to age and monitor thousands of power supplies at one time.

The fundamental proposition underlying HALT/HASS testing is that if a product and its manufacturing processes are properly designed and verified with HASS, then production operations should turn out reliable units. Consequently, if HASS detects units failing prematurely in production, this usually indicates improper manufacturing practices and/or random part failures.

Typically, the reliability of a population of products can be characterized by the bathtub-shaped curve shown in **Figure 9-3**. This curve has three distinct failure rate regions. The first region is the “infant mortality” section of the curve, which has a decreasing failure rate and is associated with built-in, rather than designed-in, defects. These are the types of defects often identified by HALT. The amount of time required for a subsequent HASS test is determined by the width of the

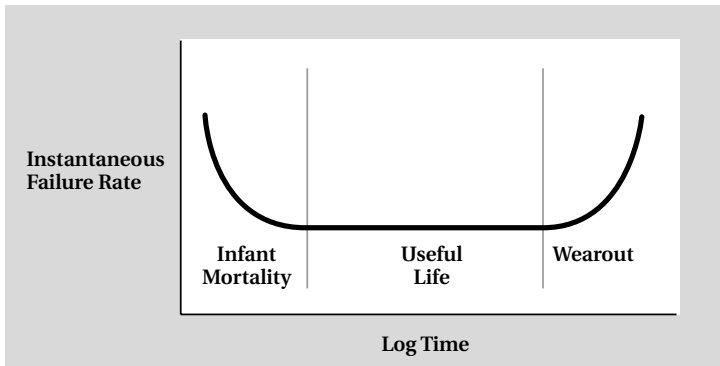
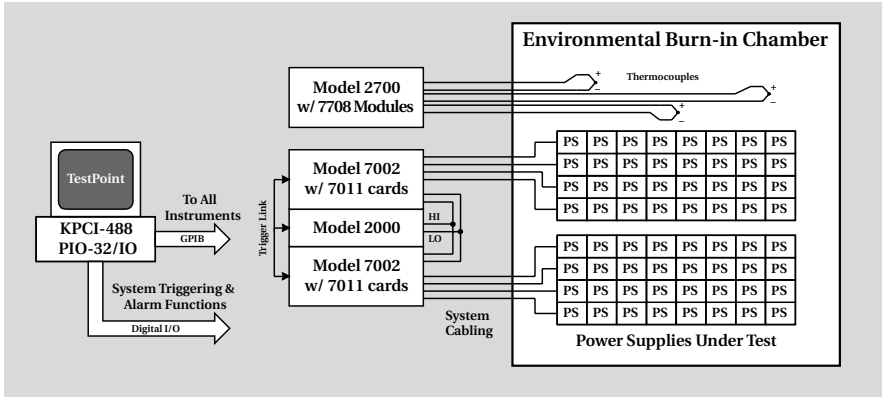

Figure 9-3. Product reliability curve

infant mortality region of the reliability curve. In general, the higher the stress applied, the sooner the failures will occur, which narrows the infant mortality region, and shortens the required HASS test period.

When designing this type of test system (**Figure 9-4**), the greatest challenges are dealing with the high number of channels the system must monitor and the test system surroundings. Large numbers of switching power supplies can produce tremendous amounts of electrical noise, which can affect the test system's measurement performance significantly.



**Figure 9-4.** Configuration of an 800-channel switching power supply burn-in test system

The basic requirement for burn-in testing of power supplies is to measure the voltage drop across a load resistor placed across the output of each switching power supply during the entire test cycle. Test cycle duration can range from less than an hour to many days, depending on the manufacturer's quality requirements.

A typical specification for a power supply is to output 5V with 10% accuracy, which can be verified easily with a 6½-digit DMM. The output is cycled every 15 seconds, and the DMM must make measurements on 800 channels during the 15 second "on" time. Setting the integration rate or measurement time to be as fast as possible (NPLC = 0.01), disabling all filters, and using the Trigger Link feature found on many Keithley instruments greatly simplifies measurement execution.

The Model 2700 Multimeter/Data Acquisition System is used to verify the temperature profile of the environmental temperature chamber independently. Plugging two Model 7700 20-channel differential multiplexer modules into the Model 2700 allows the system to accommodate up to 40 thermocouples. Two Model 7708 40-channel differential multiplexer modules can support up to 80 thermocouples.

The PIO-32 I/O relay board within the PC is used for various triggering and alarm functions. The KPCI-488 is the GPIB controller board that communicates with the instruments. This system has to be optimized by using synchronization and triggering techniques, and by taking advantage of the environmental noise rejection built into the instruments.

## 9.7 Performance Characterization of Shock Absorbers

During R&D and production test processes, manufacturers perform multiple tests to ensure devices meet the necessary specifications. In this example, the device under test is a shock absorber. The objective is to characterize shock absorber performance by plotting load vs. velocity, acceleration, linear position, or other parameters. This is a typical low cost data acquisition test system that involves a low channel count (<16 channels), high sampling rates, tight synchronization, triggering, and a high level of integration. The test system must be cost-effective because it will be duplicated on multiple stations. It must also be a fully automated, turnkey system.

The KPCI-3102 board and MB signal conditioning modules are well suited to this application. **Figure 9-5** describes the data acquisition system. The MB-05 is the signal conditioning accessory and the STA-300 is the screw terminal accessory.

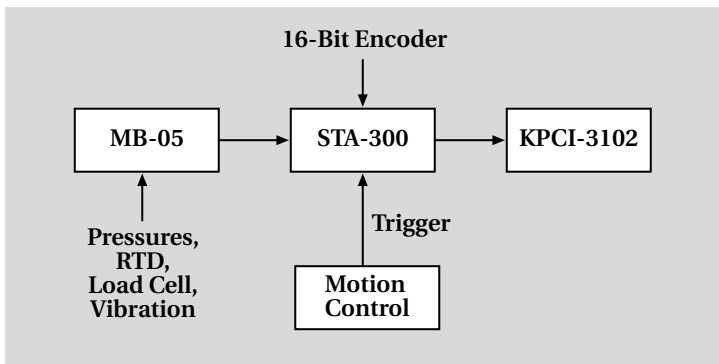

*Figure 9-5. Shock absorber test system*

As shown in **Figure 9-5**, a third-party motion control assembly triggers the data collection using a load cell, an RTD, multiple pressure sensors, accelerometers, and the binary output from a 16-bit encoder that senses the linear position of the shock absorber. To synchronize the analog inputs with the encoder, the plug-in board must include a digital channel in the scan list. The KPCI-3102 board provides this capability. The test also requires burst mode operation to minimize time skew

(~10µs) between channels, so that the measured parameters are synchronized in the time domain and represent the true behavior of the DUT. The A/D board should be able to achieve a sampling rate of up to 100kHz to capture vibration parameters, pressure, and valve flutter.

## **9.8 Instrument-Grade, Low Cost Analog Output Control**

Today, the electronics community is moving away from traditional test and measurement philosophies and toward a more hybrid approach. Until relatively recently, if the application required generating or measuring very precise data points, few solutions were available other than bench-top instruments. However, the continuing evolution of electronic components has led to the fabrication of precise voltage sources and high resolution A/D and D/A hardware, creating a variety of new solutions.

Series KPCI-3130 analog output boards offer the ability to generate instrument quality analog voltages. Designed to the PCI-bus standard, the KPCI-3130 Series provides a wide feature set that is typically not seen in PC-based plug-in analog output hardware. Two unique characteristics of the board are the four-wire remote sense feature and the four-quadrant source/sink operation. The following test examples illustrate the functionality of these features.

### **9.8.1 Four-Wire Remote Sense Test Description**

The ability of Series KPCI-3130 boards to perform four-wire remote sense operations is a significant advantage over standard analog output hardware. This feature becomes critically important when transmitting control signals over long distances because significant voltage drops can occur as the result of cable resistance, device interconnections, and terminations. Therefore, the programmed output value may not be the voltage delivered to the device under test (DUT) when conventional sourcing methods are used.

Incorporating four-wire remote sense functionality makes it possible to connect sense leads directly to the input of the DUT. The sense high and low connections allow the board to measure (sense) the actual voltage present at the DUT. The board can then adjust its output automatically, without user intervention, to ensure that the required voltage is supplied, regardless of cable length and interconnection losses.

### **9.8.2 Four-Wire Remote Sense Test Procedure**

In this test, a known voltage level is programmed from the KPCI-3130 and connected to the DUT using several different cable lengths. The output voltage is programmed with ExceLINX™ software (Keithley's Excel add-in), and the resistance of the cable measured using a Keithley Model 2700 Multimeter/ Data Acquisition System that is set to

four-wire ohms mode. For comparison purposes, the voltage at the DUT is also measured without remote sense (two-wire mode).

The load is connected to the analog output in two-wire mode as shown in **Figure 9-6**, and then connected in four-wire mode using the sense line inputs as shown in **Figure 9-7**. The OUT0 and GND signals are connected to pins 1 and 19 respectively; the S0H and S0L signals are connected to pins 2 and 20.

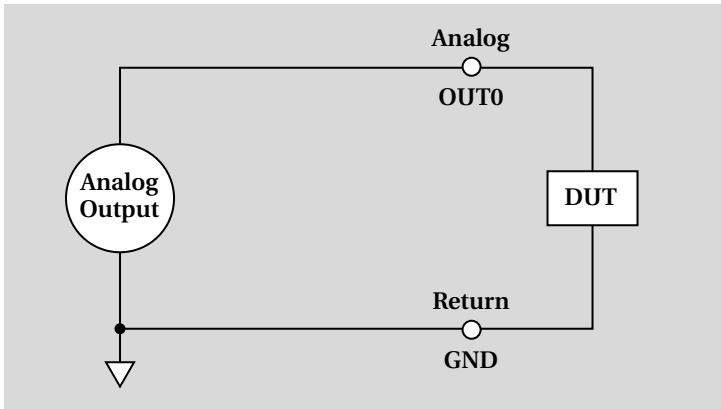

Figure 9-6. Conventional two-wire analog output connections

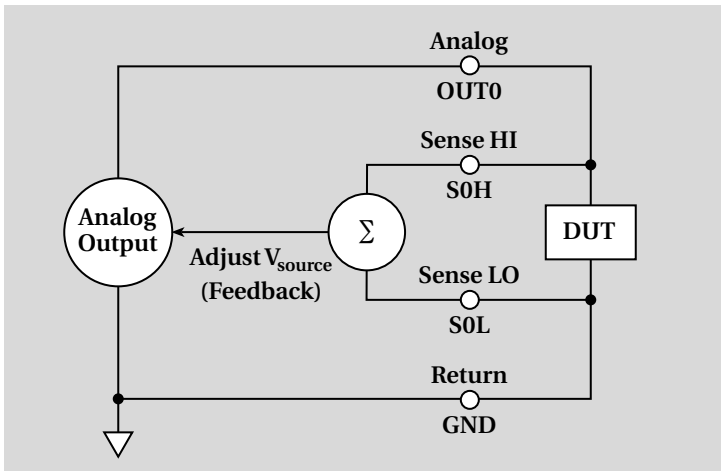

Figure 9-7. Analog output with four-wire remote sense

The data in **Table 9-1** was obtained using the KPCI-3130 board's source feature and a Model 2700 Multimeter/Data Acquisition System. The data clearly indicates that cabling and device interconnections can be significant sources of error.

*Table 9-1. Lead resistance and programmed voltage in two-wire and four-wire modes*

Signal Path (Per lead)	Resistance ( $\Omega$ per lead)	Programmed Value (V)	Two-Wire Mode Measured Value (V)	Four-Wire Mode Measured Value (V)
10ft. cable	0.5266	8.000	7.999	8.000
100ft. cable	2.5	8.000	7.920	8.000
6 relays, 4 interconnections, 20ft. cable	4.06	8.000	7.360	8.000

### 9.8.3 Constant Current Source Test Description

Another unique feature of the KPCI-3130 is its ability to operate in all four voltage/current quadrants (**Figure 9-8**). Four-quadrant operation is the ability of a device to sink or source any combination of current or voltage. The KPCI-3130 can perform these operations on each of its eight channels simultaneously. Additionally, the robust nature of the analog outputs permits sinking or sourcing up to  $\pm 10V$  @ 20mA, without the need for external excitation. This feature is usually available only on bench-top systems.

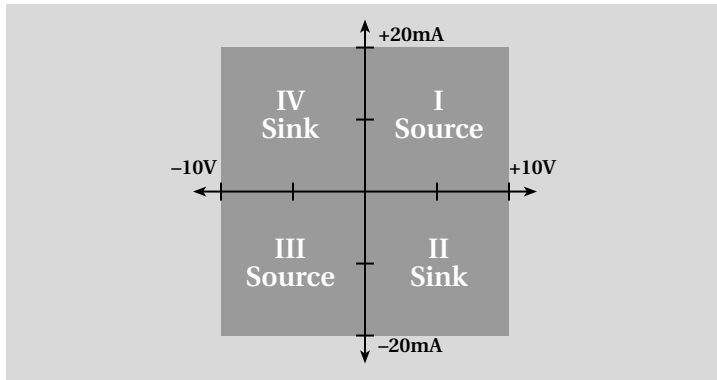

*Figure 9-8. Four-quadrant operation*

The examples outlined in Sections 9.8.4 and 9.8.5 illustrate the process of configuring a constant current supply that will function in Quadrants I and III. The key to generating the desired output current is

selecting the proper shunt resistor. This shunt resistor is placed in series with the load, and the analog output across the shunt is maintained at a level that results in the desired current passing through the load/shunt pair.

#### 9.8.4 Quadrant I, Resistive Load Test Procedure

This example explores an application with a test sample (resistive load) that requires a constant current to be applied and controlled, independent of the load. Typically, the load resistance and current requirements are known. From this information, we can derive the proper shunt resistor value using Ohm's Law and the sum of the series resistance of the load/shunt combination.

This example assumes the load is 490Ω, the desired current is 20mA, and the applied voltage is 10V. From Ohm's Law, we can calculate  $R_{shunt}$ :

$$\begin{aligned}V_{ao} &= (R_{total} \times I) \\ &= (R_{shunt} + R_{load}) \times 20\text{mA} \\ 10\text{V} &= (R_{shunt} + 490\Omega) \times 20\text{mA}\end{aligned}$$

Therefore:

$$\begin{aligned}R_{shunt} + 490\Omega &= 10\text{V}/20\text{mA} \\ R_{shunt} + 490\Omega &= 500\Omega \\ R_{shunt} &= 500\Omega - 490\Omega = 10\Omega\end{aligned}$$

The analog output voltage will now be a function of the voltage programmed, and sensed, across the shunt resistor. The acceptable shunt voltage levels can once again be determined using Ohm's Law and the specified current:

$$\begin{aligned}V_{max\ shunt} &= 20\text{mA} \times R_{shunt} \\ &= 20\text{mA} \times 10\Omega \\ &= 0.2\text{V}\end{aligned}$$

Therefore, if 0.2V is programmed, referenced to the shunt resistor, the output across the series resistor network results in 10V @ 20mA. Other current levels can be obtained in the same manner. For example, if the required drive current were 10mA, the control voltage would be 0.1V.

For this test, connect the load and shunt resistors to the analog output and sense lines as shown in **Figure 9-9**. Connect the OUT0 and GND signals to pins 1 and 19 respectively, and then connect the S0H and S0L signals to pins 2 and 20.

Note that the shunt resistor must be connected on the ground side of the load if the analog output is to function properly (**Figure 9-9**). Failure to do so will result in unpredictable behavior from the analog output circuit, and may damage the circuit under test.



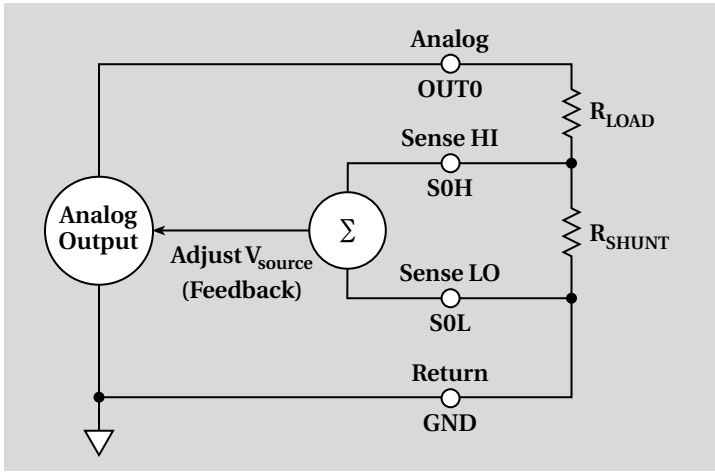

Figure 9-9. Constant current configuration

### 9.8.5 Quadrant I and III, Battery Charge/Discharge Test Procedure

Let's consider another application that requires two-quadrant operation. This application involves battery charge/discharge cycle testing using a constant current source. The first half of the test requires charging the battery to a specific voltage level (9.6V), then discharging the battery to another predetermined level (1.0V).

The charge cycle occurs in Quadrant I, where both the voltage and current are positive. The discharge cycle occurs in Quadrant III, where the voltage and current are negative. A shunt resistor will be selected in order to limit the charge and discharge currents to a predetermined safe level (in this case, 10mA). The load resistance of the battery source is quite low and is assumed to be negligible (less than  $0.1\Omega$ ). Therefore, the following calculations assume the load resistance is less than  $0.1\Omega$  and therefore negligible. A  $10\Omega$  shunt resistor is used in the following calculation.

The analog output voltage will now be a function of the voltage programmed and sensed across the shunt resistor. The acceptable programmed shunt voltage levels can once again be determined using Ohm's Law and the required current:

$$\begin{aligned}
 V_{\max \text{ shunt}} &= 10\text{mA} \times R_{\text{shunt}} \\
 &= 10\text{mA} \times 10\Omega \\
 &= 0.1\text{V}
 \end{aligned}$$

The shunt circuit analog output can now be set to 0.1V for the charge cycle and  $-0.1\text{V}$  for the discharge cycle. The actual battery volt-

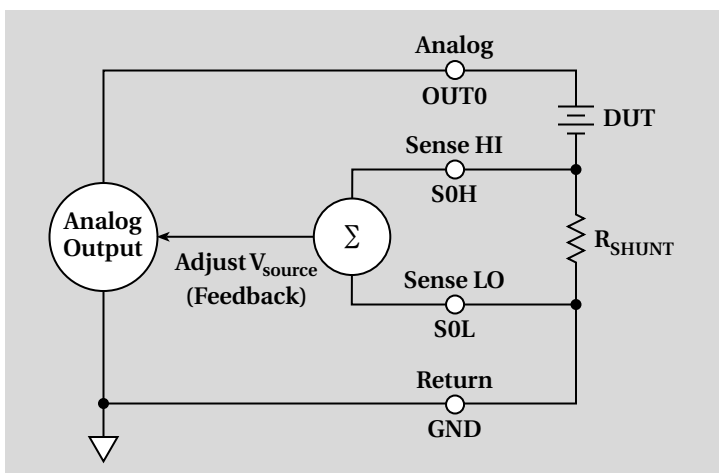

Figure 9-10. Constant current battery test configuration

age levels can be monitored using an analog input board, such as the KPCI-3101. A user-written program would command and control the specific voltage levels on the KPCI-3130.

For this test, connect the load and shunt resistor to the analog output and sense lines as shown in **Figure 9-10**. Connect the OUT0 and GND signals to pins 1 and 19 respectively, and connect the S0H and S0L signals to pins 2 and 20.

### 9.8.6 Source/Sink Test Description

Finally, we discuss the steps necessary to perform a battery charge/discharge cycle test in constant voltage operating mode. Unlike the previous example, the KPCI-3130 both sources voltage and sinks current.

### 9.8.7 Quadrant I and II, Battery Charge/Discharge Test Procedure

This test involves charging the battery to a specific voltage level, then discharging it to another predetermined level. The charge cycle occurs in Quadrant I, where both the voltage and current are positive. The discharge cycle occurs in Quadrant II, where the voltage is positive and the current is negative. A series resistor must be selected to limit current. The resistor value is based on the voltage and current specifications of the DUT. The load resistance of the battery source is quite low. Therefore, the following calculations assume load resistance is less than  $0.1\Omega$  and therefore negligible.

The analog output voltage will be a function of the voltage programmed and sensed across the series combination of the battery and resistor. This example assumes the maximum charge current is 10mA,

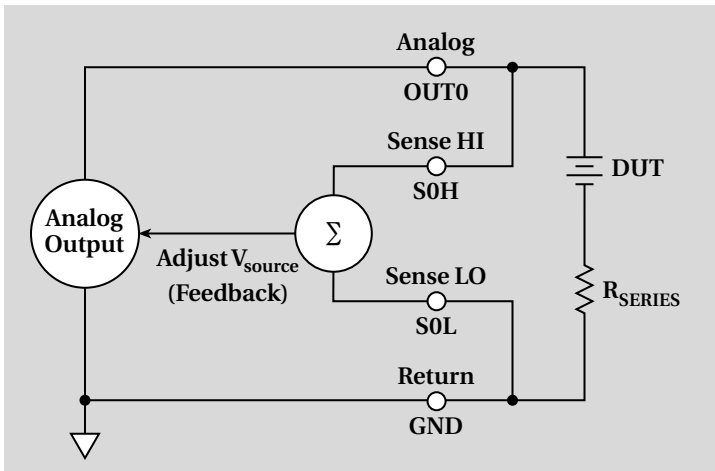

Figure 9-11. Constant voltage battery test configuration

the maximum voltage is 9V, and the minimum voltage is 3V. A suitable series resistance can now be selected based on the test requirements:

$$\begin{aligned}
 R_{\text{series}} &= V_{\text{change}}/I_{\text{max}} \\
 &= (9.0 - 3.0)/10\text{mA} \\
 &= 600\Omega
 \end{aligned}$$

The analog output can now be set to 9.0V for the charge cycle and 3.0V for the discharge cycle. The actual voltage levels can be monitored using an analog input board, such as the KPCI-3101, and the test cycle can be controlled via the user program.

Note that, unlike the constant current example outlined previously, the exact current level sourced and sunk by the KPCI-3130 will vary with the level of charge of the DUT (a battery in this case). Also, the current flow will be reduced as the potential of the DUT approaches that of the programmed analog output. Therefore, it is critical to select the correct series resistance to limit the maximum current from the analog outputs. Failure to do so can result in damage to the DUT.

For this test, connect the load and shunt resistor to the analog output and sense lines as shown in **Figure 9-11**. Connect the OUT0 and GND signals to pins 1 and 19 respectively, and connect the S0H and S0L signals to pins 2 and 20.

Series KPCI-3130 universal analog output boards offer a versatile feature set, which makes them appropriate for a wide range of control applications. Furthermore, the four-wire sense function ensures that the DUT is actually being controlled at the voltage level that was pro-

grammed; this was evident in the first test example. This four-wire sense feature is only available from Keithley's analog output boards. Additionally, the four-quadrant operation and the 20mA sink/source current capability can simplify test setup and reduce equipment requirements.



---

APPENDIX A

**Selection Guide for  
Plug-In Boards vs.  
External Data Acquisition  
Instruments**

---

**FEATURES/CAPABILITIES**

	<b>Plug-in Boards</b>	<b>External Instruments</b>
<b>MEASUREMENT</b>		
<b>Sampling rate</b>	High. > 1kHz.	Low. <1kHz.
<b>A/D technology</b>	Sampling (successive approximation).	Integrating (power line cycle integration).
<b>Data throughput, measurement to user</b>	High speed. >1kHz.	Low. <1kHz.
<b>Measurement accuracy</b>	Moderate. Approx. 100µV.	High. Approx. 1µV.
<b>Resolution/Sensitivity</b>	Moderate (8-16 bit).	High (22-28 bit).
<b>Calibration</b>	NIST traceable.	NIST traceable.
<b>Multiplexing/Switching</b>	Solid-state. High speed.	Mechanical. High isolation and accuracy.
<b>SIGNAL CONDITIONING</b>		
<b>Electrical isolation to earth ground</b>	None. Additional modules required.	Built in, up to 1000V.
<b>Noise immunity</b>	Low to moderate.	High.
<b>Common mode voltage</b>	10V.	Up to 1000V.
<b>Signal conditioning (res., TC, current, freq.)</b>	Additional modules required.	Built in conditioning hardware.
<b>Scaling/Engineering units/Limits</b>	Required. Included in software.	Built in.
<b>Digital filtering</b>	Required. Included in software.	Built in.
<b>SOFTWARE</b>		
<b>Communication bus</b>	PCI/ISA/PCMCIA.	GPIB, RS-232.
<b>Computer dependence/coupling</b>	Tightly coupled.	Loosely coupled.
<b>System software dependence</b>	Highly dependent. Device drivers required.	Independent. Standard bus (GPIB, RS-232).
<b>Application program response time</b>	High. <1ms.	Moderate, > 1ms.
<b>Control capabilities (analog out, digital out)</b>	High. Fast response-time <1ms.	Moderate. Response time > 1ms.

**FEATURES/CAPABILITIES**

	<b>Plug-in Boards</b>	<b>External Instruments</b>
<b>FORM FACTOR</b>		
<b>Channel expandability</b>	Limited. PC slot dependent.	Almost unlimited. Daisy-chained.
<b>Multifunctionality (AI, AO, DIO, CT)</b>	High.	Moderate.
<b>Modular/Customizable</b>	High. A la carte.	Moderate. All functions built in.
<b>Rack space</b>	None. Plugs into the computer chassis.	Rack/stack, benchtop.
<b>Compactness, embedding capabilities</b>	High. Ideal for OEM integration.	Moderate, stand-alone.
<b>OTHER</b>		
<b>Ease of use</b>	Moderate. Requires software.	High. Pushbutton and display interface.
<b>Front panel display</b>	None. Requires GUI software.	Pushbutton display - troubleshooting.
<b>Usage</b>	Component level. Integration required.	System level.
<b>Cost</b>	Low. <\$1000	Moderate. >\$1000.





---

APPENDIX B

Glossary

---

**2'S COMPLEMENT.** A 2's complement is derived by reversing the digits in a binary number (changing 1s to 0s and 0s to 1s) and adding 1 to the result. When 2's complements are used to represent negative numbers, the most significant (leftmost) digit is always 1.

**A/D CONVERTER.** *See* ANALOG-TO-DIGITAL CONVERTER.

**A/D.** Abbreviation for analog-to-digital. *Also See* ANALOG-TO-DIGITAL CONVERTER.

**ABOUT-TRIGGER ACQUISITION MODE.** A data acquisition triggering mode in which the data acquisition is started by an internal or external trigger, then continues after a second trigger event, thus retaining data both before and after the second trigger. *See also* TRIGGER (DATA ACQUISITION) *and* TRIGGER MODES.

**ABSOLUTE ACCURACY.** A measure of the uncertainty of an instrument reading compared to that of a primary standard having absolute traceability to the National Institute of Standards and Technology, expressed in ppm. Accuracy is often separated into gain and offset terms. *See also* RATED ACCURACY.

**ACQUISITION RATE.** The rate at which the board acquires analog or digital data from an external signal input to the board. In the case of a scanning A/D, the aggregate conversion rate for all channels.

**ACQUISITION TIME.** In general, the minimum amount of time that an analog signal must be present at the input of an A/D converter for a conversion to take place. For a sampling A/D converter, the acquisition time specifies the time that the analog signal must be present at the SH front end before the A/D conversion starts. Also referred to as "Aperture Time" and "Sample Window." *See also* ANALOG-TO-DIGITAL CONVERTER, SAMPLING ANALOG-TO-DIGITAL CONVERTER, *and* SAMPLE-AND-HOLD.

**ACTIVE EDGE.** The definition of which edge of a trigger signal (positive, rising edge, or the negative, falling edge) will be used to initiate an action. Data acquisition systems typically may be configured to specify either edge as a trigger event. *See also* TRIGGER (DATA ACQUISITION) *and* TRIGGER POLARITY.

**ADC.** *See* ANALOG-TO-DIGITAL CONVERTER.

**ADDRESS.** A number specifying a location in memory where data is stored.

**ADMITTANCE.** The reciprocal of the impedance. The admittance is the complex ratio of the current flowing through divided by the voltage across a device, circuit element, or network.

**ALIASING.** False artifacts produced in data when sampling rate is less than twice the input signal's highest frequency content.

- ANALOG OUTPUT.** An output that provides an analog signal derived from the input signal or digital information within an instrument.
- ANALOG RAMP.** A voltage output of constant slope,  $dV/dt$  (volts/second).
- ANALOG TRIGGER.** An event that occurs at a user-selected point on an analog input signal. The polarity, sensitivity, and hysteresis of the analog trigger can often be programmed. *See also* TRIGGER, TRIGGER CONDITIONS, TRIGGER HYSTERESIS, TRIGGER MODE, TRIGGER POLARITY, *and* TRIGGER SENSITIVITY.
- ANALOG-TO-DIGITAL CONVERTER.** An electronic device that converts an analog voltage to a digital value. All digital instruments use analog-to-digital converters to convert the input signals into digital information. Also called an A/D converter or an ADC.
- ANGSTROM.** A unit of length equal to  $10^{-10}$  meters. Thus, there are ten angstroms to one nanometer (nm).
- APERTURE DELAY.** The time delay between when an analog-to-digital converter receives a conversion command and when it starts the conversion process. *See also* ANALOG-TO-DIGITAL CONVERTER, APERTURE JITTER.
- APERTURE JITTER.** The short-term variation of aperture delay. Also called “Aperture Uncertainty.” *See also* APERTURE DELAY.
- APERTURE TIME.** The time interval during which an amplifier or measuring instrument acquires a sample of the signal. Also known as the sample window. *See also* ACQUISITION TIME.
- APERTURE UNCERTAINTY.** *See* APERTURE JITTER.
- API.** *See* APPLICATION PROGRAMMING INTERFACE.
- APPLICATION PROGRAM.** A computer program used to perform a particular kind of work, such as data acquisition. Examples of application programs include high-level packages such as TestPoint™ or user programs written using function call drivers or low-level calls.
- APPLICATION PROGRAMMING INTERFACE.** A set of routines used by an application program to direct the performance of a procedure by the computer’s operating system.
- ASYNCHRONOUS.** In hardware, an unsynchronized event that occurs independent of other events. In software, a function that begins an operation and returns to the calling program prior to the completion of the operation.
- AUTOPOLARITY.** The ability of an instrument to measure and display an input of either polarity without switching the input leads.

**AUTORANGING TIME.** For instruments with autoranging capability, the time interval between application of a step input signal and its display, including the time for determining and changing to the correct range.

**AUTORANGING.** The ability of an instrument to switch among ranges automatically. The ranges are usually in decade steps.

**AVERAGE RESPONDING.** A measurement where the displayed value is proportional to the average of the absolute values of all input waveforms within a specified frequency range. It is calibrated in the rms value of a sine wave.

**BACKGROUND TASK.** An operation that can take place while another program or processing routine is running without apparent interruption to that program or routine; for example, an interrupt or DMA operation.

**BANDWIDTH (DATA ACQUISITION).** The range of frequencies that can be switched, conducted, or amplified within certain limits. Under given load conditions, bandwidth is defined by the  $-3\text{dB}$  (half-power) points. Also, the highest frequency signal component that can pass through an amplifier or filter without being attenuated.

**BANK.** A group of relays with a common connection for scanning or multiplexing applications.

**BASE ADDRESS.** An I/O address that is the starting address for programmable registers. All subsequent registers are accessed by adding to the base address.

**BETA.** The ratio of the collector current to the base current of a bipolar transistor, commonly referred to as either the common-emitter current gain or the current amplification factor.

**BIAS CURRENT (IN DIFFERENTIAL AMPLIFIER).** A small current drawn through an input terminal of a differential amplifier.

**BIAS VOLTAGE.** A voltage applied to a circuit or device to establish a reference level or operating point of the device during testing.

**BIPOLAR.** An analog signal range that includes both positive and negative values.

**BREAK-BEFORE-MAKE.** Disconnecting the present circuit before connecting a new circuit.

**BUFFER MEMORY.** Temporary storage area for acquired or generated data. *See also* LOCAL BUFFER.

**BURN-IN.** The operation of items prior to their ultimate application, intended to stabilize their characteristics and identify early failures.

**BURST CLOCK FREQUENCY.** *See* BURST CLOCK RATE.

**BURST CLOCK RATE.** The rate at which timing pulses are emitted from a pacer clock. *See also* BURST CLOCK, BURST CONVERSION MODE.

**BURST CLOCK.** For a data acquisition board operating in the burst mode, a pulse-emitting circuit that determines the analog data conversion rate. *See also* BURST CONVERSION MODE *and* CONVERSION RATE.

**BURST CONVERSION MODE.** A data acquisition mode in which a group of analog input channels are scanned at a rate determined by the pacer clock and each channel within the group is converted at a higher rate determined by the burst clock. This mode minimizes the skew between channels. *See also* BURST CLOCK *and* PACER CLOCK.

**BUS MASTERING.** On a microcomputer bus such as the PCI bus, the ability of an expansion board to take control of the bus and transfer data to memory at high speed, independently of the CPU. Replaces direct memory access (DMA).

**BUS.** An interconnection system that allows each part of a computer to communicate with the other parts.

**BYTE.** A group of eight bits.

**CAPACITANCE.** In a capacitor or system of conductors and dielectrics, the property that permits the storage of electrically separated charges when potential differences exist between the conductors. Capacitance is related to charge and voltage as follows:  $C = Q/V$ , where C is the capacitance in farads, Q is the charge in coulombs, and V is the voltage in volts.

**CARRY CURRENT.** The maximum continuous current of closed relay contacts. Most relays are rated higher for carry current than switched current. (Heat is generated by  $I^2R$  losses for carry current and  $I^2R$  losses plus arcing for switched current.) *See also* SWITCHED CURRENT.

**CHANNEL (SWITCHING).** One of several signal paths on a switching card. For scanner or multiplex cards, the channel is used as a switched input in measuring circuits or as a switched output in sourcing circuits. For switch cards, each channel's signal paths are independent of other channels'. For matrix cards, a channel is established by the actuation of a relay at a row and column crosspoint. *See also* PATH.

- CHANNEL ISOLATION.** On a switching card, the isolation from signal high and low of one channel to signal high and low of any other channel (or the output on switch or scanner cards). Specified as resistance and capacitance, except for RF cards (decibels and frequency range). *See also* PATH ISOLATION.
- CHANNEL.** On a data acquisition board, one of several input or output paths on the board. Multiple analog input channels are commonly connected to one analog-to-digital converter, one at a time, using a multiplexer. *See also* MULTIPLEXER *and* ANALOG-TO-DIGITAL CONVERTER.
- CHANNEL-GAIN QUEUE.** A user-defined scan sequence in a data acquisition device. It specifies both the position in the sequence and the gain at which an analog input channel is scanned, or in some cases, the output range at which an analog output channel is updated. It can also specify whether the input or output mode is bipolar or unipolar and whether the input mode is single-ended or differential. *See also* CHANNEL *and* SCAN (DATA ACQUISITION).
- CHARGE COUPLED DEVICE (CCD).** A semiconductor device, often used for sensing light, which operates by storing charge on capacitors and selectively moving that charge through the device by manipulating voltages on its electrodes.
- CMRR.** *See* COMMON MODE REJECTION RATIO (CMRR).
- COIL RESISTANCE.** A nominal value of the resistance of a relay coil winding at a specified ambient temperature.
- COLD JUNCTION.** The junction in a thermocouple circuit that is held at a stable, known temperature. Also known as a *reference junction*.
- COLD JUNCTION COMPENSATION (CJC).** A method of compensating for ambient temperature variations in thermocouple circuits by using either a physical cold junction or by measuring ambient temperature to adjust collected values.
- COLD SWITCHING.** Closing the relay contacts before applying voltage and current and removing voltage and current before opening the contacts. (Contacts do not make or break current.) *See also* DRY CIRCUIT SWITCHING.
- COLUMN.** As viewed on the schematic of a matrix relay card, the vertical signal lines or a vertical group of relays.
- COMMON MODE INPUT ISOLATION.** On a switching card, the isolation from signal high and low to guard (or shield) for a three-pole circuit, or from signal high and low to chassis ground for a two-pole circuit. Specified as resistance and capacitance.

- COMMON MODE REJECTION RATIO (CMRR).** The ability of an instrument to reject interference from a common voltage at its input terminals with respect to ground. Usually expressed in decibels at a frequency.
- COMMON MODE VOLTAGE.** A voltage between input low and chassis ground of an instrument. A differential input “sees” the common mode voltage as a common component of the voltages at both the input-high and input-low terminals and rejects all but a small fraction. *See also* COMMON MODE REJECTION RATIO (CMRR) *and* DIFFERENTIAL INPUT.
- COMPLIANCE CURRENT.** The maximum output current of a constant voltage source. Also known as current limit.
- COMPLIANCE VOLTAGE.** The maximum output voltage of a constant current source. Also known as voltage limit.
- CONDUCTANCE (G).** The ability to conduct electricity. Defined by  $G = 1/R = I/V$ , where G is the conductance in Siemens, I is the current in Amps, and V is the voltage in Volts.
- CONNECTION PATH.** The cables, connectors, switch cards, etc. between a device under test (DUT) and test instrumentation. Its major parts are the conductors making the connection and the insulators isolating the conductors from the rest of the world.
- CONTACT BOUNCE.** The intermittent and undesired opening of relay contacts during closure, or closing of relay contacts during opening.
- CONTACT LIFE.** The maximum number of expected closures before failure. Life is dependent on the switched voltage, current, and power. Failure is usually when the contact resistance exceeds an end of life value.
- CONTACT OFFSET VOLTAGE.** *See* CONTACT POTENTIAL.
- CONTACT POTENTIAL.** A voltage produced between contact terminals due to the temperature gradient across the relay contacts (typically caused by power dissipated by the energized coil.), and the reed-to-terminal junctions of dissimilar metals. Also known as *contact offset voltage*. *See* THERMOELECTRIC VOLTAGE.
- Contact Rating.** The voltage, current, and power capacities of relay contacts under specified environmental conditions. *See* CARRY CURRENT *and* SWITCHED CURRENT.
- CONTACT RESISTANCE.** For a relay, the resistance in ohms across closed contacts. For a Keithley switching card, also includes the tape resistance and connector terminal resistance. *See also* PATH RESISTANCE.
- CONVERSION RATE.** The rate at which sampled analog data is converted to digital data or digital data is converted to analog data.



- CONVERSION TIME.** The time required to complete an analog-to-digital or digital-to-analog conversion.
- CONVERSION.** A process where a signal is changed from an analog-to-digital (A-D) representation, or digital-to-analog (D-A).
- COULOMB.** The unit of electric charge, defined as the amount of charge accumulated in one second by a current of one ampere. One coulomb represents the charge on approximately  $6.24 \times 10^{18}$  electrons. Named for French physicist Charles-Augustin de Coulomb (1736-1806).
- COUNTER/TIMER.** A circuit that counts pulses or measures pulse duration.
- CREST FACTOR.** The ratio of the peak value to the root-mean-square (rms) value of a waveform.
- CROSSPOINT.** The intersecting point of a column and row in a relay matrix. Specified as (column,row) or (row,column). A crosspoint generally consists of one or more poles of Form A (normally open) relay switching.
- CROSSTALK.** The coupling of a signal from one input to another (or from one channel to another or to the output) by conduction or radiation. Crosstalk is expressed in decibels at a specified load and up to a specific frequency.
- D/A CONVERTER.** *See* DIGITAL-TO-ANALOG CONVERTER.
- D/A.** Abbreviation for *digital-to-analog*.
- DAC.** *See* DIGITAL-TO-ANALOG CONVERTER.
- DARLINGTON.** A high-gain current amplifier composed of two cascaded bipolar transistors, typically integrated in a single package.
- DAS.** Data Acquisition System.
- DATA TRANSFER.** Refers to the way data is transferred to and from memory, such as programmed I/O or DMA mode.
- DDE.** *See* DYNAMIC DATA EXCHANGE.
- DEVICE HANDLE.** A name that uniquely identifies a hardware device in an application program.
- DIELECTRIC.** An insulating layer. A material that has high resistance. This term is usually used when the insulating layer separates the plates of a capacitor.
- DIFFERENTIAL AMPLIFIER.** An analog input circuit that measures the difference between the voltages at two input terminals—input high and input low, each of which is referenced to a common ground. A differential input rejects the common mode voltage—the common voltage relative to ground, as measured at the input low terminal—to an extent limited by the common-mode rejection ratio of the circuit. *See also* COMMON MODE VOLTAGE, COMMON-MODE REJECTION RATIO (CMRR), *and* SINGLE-ENDED INPUT.

- DIFFERENTIAL INPUT.** The condition where the low terminal of a two-terminal instrument is connected to a reference point which is not necessarily a power line common, earth ground, or circuit common. Typically, a data acquisition board with multiple differential input channels may have each low terminal at a different potential. *See also* SINGLE-ENDED INPUT.
- DIFFERENTIAL INPUT ISOLATION.** On a switching card, the isolation from signal high to low. Specified as resistance and capacitance.
- DIFFERENTIAL LINEARITY.** *See* DIFFERENTIAL NONLINEARITY (DNL).
- DIFFERENTIAL NONLINEARITY (DNL).** The maximum deviation of a real digitized step width or height from the ideal digitized step width or height. The input range of a data acquisition board is divided into a series of discrete steps, each step ideally having a height of one least significant bit (LSB). *See also* LEAST SIGNIFICANT BIT (LSB), ANALOG-TO-DIGITAL CONVERTER, *and* QUANTIZATION.
- DIGITAL I/O.** Abbreviation for *digital input/output*.
- DIGITAL LINES/PORTS/BITS/CHANNELS.** In hardware, a digital line is physical hardware connection to a pin with a digital signal. A digital port is a physical grouping of digital lines. In software, a digital bit (1 or 0) is a logical representation of a digital line. A digital channel is a logical grouping of digital bits.
- DIGITAL TRIGGER.** An event that occurs at a user-selected point on a digital input signal. The polarity and sensitivity of the digital trigger can often be programmed. *See also* TRIGGER, TRIGGER CONDITIONS, TRIGGER POLARITY, *and* TRIGGER SENSITIVITY.
- DIGITAL-TO-ANALOG CONVERTER.** A device that translates digital data to an analog signal. A digital-to-analog converter takes a succession of discrete digital values as input and creates an analog signal whose amplitude, moment by moment, corresponds to each digital value. Compare to ANALOG-TO-DIGITAL CONVERTER.
- DIRECT DIGITAL SYNTHESIS.** A technique for signal generation where the signal is directly synthesized using only digital techniques. This technique generates very precise waveforms, even at low frequencies. Waveforms with correct phase and frequency are obtained immediately after a shift to a new frequency.
- DIRECT MEMORY ACCESS (DMA).** *See* DMA (DIRECT MEMORY ACCESS) MODE.

**DISCRETE DEVICE.** A class of electronic components that contain one active element, such as a transistor or diode. However, hybrids, optoelectronic devices, and intelligent discretely may contain more than one active element.

**DLL.** *See* DYNAMIC LINK LIBRARY.

**DMA (DIRECT MEMORY ACCESS) CHANNELS.** ISA bus PCs offer eight parallel channels for DMA mode data transfers. A number of these are reserved for exclusive use by the computer. The remaining channels are available for use by user-supplied I/O options, such as plug-in data acquisition boards. Also called *DMA levels*.

**DMA (DIRECT MEMORY ACCESS) LEVELS.** *See* DMA (DIRECT MEMORY ACCESS) CHANNELS.

**DMA (DIRECT MEMORY ACCESS) MODE.** A mode in which data transfers directly between an I/O device and computer memory, bypassing the CPU. Most commonly, DMA mode refers to data transfers across the ISA bus, using special circuitry on the computer motherboard. In the most general sense, PCI bus mastering is a DMA mode. *See also* BUS MASTERING *and* OPERATION MODES.

**DMM.** An electronic instrument that measures voltage, current, resistance, or other electrical parameters by converting the analog signal to digital information and display. The typical five-function DMM measures DC volts, DC amps, AC volts, AC amps, and resistance.

**DNL.** *See* DIFFERENTIAL NONLINEARITY.

**DRAM.** Dynamic Random Access Memory. A semiconductor read/write memory chip, in which the presence or absence of a capacitive charge represents the state of a binary storage element (zero or one). The charge must be periodically refreshed.

**DRAIN TERMINAL.** Along with the gate and source, one of the three terminals of a field-effect transistor (FET). The low impedance path through a turned-on FET is through the Source and Drain terminals. The Gate is a high impedance, voltage-controlled input.

**DRIFT.** A gradual change of a reading or an amplifier output over time with no changes in the input signal or operating conditions.

**DRIVER.** Software that controls a specific hardware device, such as a data acquisition board.

- DRY CIRCUIT SWITCHING.** Switching below specified levels of voltage (e.g., 20mV) and current to minimize any physical and electrical changes in the contact junction. *See also* COLD SWITCHING.
- DRY REED RELAY.** A glass-enclosed, hermetically sealed, magnetically actuated contact. No mercury or other wetting material is used.
- DSP.** Abbreviation for *Digital Signal Processing*.
- DUTY RATIO.** The ratio of pulse width to repetition period. Also known as *Duty Cycle*.
- DYNAMIC DATA EXCHANGE (DDE).** A Microsoft Windows standard mechanism for communication between programs. It allows your application to send and share data with other applications such as spreadsheets.
- DYNAMIC LINK LIBRARY (DLL).** A software module in Microsoft Windows containing executable code and data that can be called or used by Windows applications or other DLLs. DLL functions and data are loaded and linked at run time when they are referenced by a Windows application or other DLLs.
- EEPROM.** Electrically Erasable Programmable Read-Only Memory. Similar to PROM, but with the capability of selective erasure of information through special electrical stimulus. Information stored in EEPROM chips is retained when the power is turned off.
- EISA BUS.** Extended Industry Standard Architecture. A 32-bit wide, upwards-compatible extension of the 16-bit wide ISA bus.
- ELECTROMETER.** A highly refined DC multimeter. When compared with a digital multimeter, an electrometer is characterized by higher input resistance and greater sensitivity. It can also have functions not generally available on DMMs (e.g., measuring electrical charge, sourcing voltage).
- ENOB.** Effective Number Of Bits.
- EPROM.** Electrically Erasable Programmable Read-Only Memory. *See* EEPROM.
- EPUT.** Events Per Unit Time.
- ERROR.** The deviation (difference or ratio) of a measurement from its true value.
- EXPANSION SLOT.** A socket in a computer designed to hold expansion boards and connect them to the system bus.

- EXTERNAL PACER CLOCK SOURCE.** A source of pulses that is connected externally to a data acquisition board and is used to pace or time events such as analog-to-digital conversions, digital-to-analog conversions, data sampling, interrupt generation, digital I/O transfers, etc.
- EXTERNAL TRIGGER.** An analog or digital hardware event from an external source that starts an operation. *See also* INTERNAL TRIGGER.
- FALL TIME.** The time required for a signal to change from a large percentage (usually 90%) to a small percentage (usually 10%) of its peak-to-peak amplitude. *See also* RISE TIME.
- FIFO.** First-In/First-Out memory buffer. The first data into the buffer is the first data out of the buffer. On a data acquisition board, a FIFO allows data collection to continue while the board waits for data transfer access to the host computer.
- FIREWIRE.** A communication standard and external bus, also designated IEEE-1394, that supports Plug-and-Play, hot plugging, and data transfer rates of up to 400Mbps.
- FLASH MEMORY.** It is a non-volatile memory technique with fast access times; rewriteable many times, and uses a block erase technique (as opposed to EEPROM, which erases one bit at a time).
- FLOATING.** The condition where a common mode voltage exists between an earth ground and the instrument or circuit of interest. (Low of circuit is not at earth potential.)
- FOREGROUND TASK.** An operation, such as those that occur in the single or synchronous mode, that cannot take place while another program or routine is running.
- FOUR-TERMINAL RESISTANCE MEASUREMENT.** A measurement in which two leads are used to supply current to the unknown and two different leads are used to sense the voltage drop across the resistance.
- FPGA.** *See* FIELD-PROGRAMMABLE GATE ARRAY (FPGA).
- FRAME.** A data structure that consists of one or more elements corresponding to an operation's defining attributes.
- FUNCTION CALL DRIVER.** A type of Keithley board driver that provides a high-level alternative to register-level programming.
- GAIN.** The factor by which an incoming signal is multiplied by an amplifier.
- GATE (SIGNAL).** A signal that in the active state enables an operation and in the inactive state inhibits the operation.

- GATE TERMINAL.** Along with the source and drain, one of the three terminals of a field-effect transistor (FET). The low impedance path through a turned-on FET is through the Source and Drain terminals. The Gate is a high impedance, voltage-controlled input.
- GLITCH ENERGY.** A measure of the energy of an unwanted transient superimposed on the output of a digital-to-analog converter. A simple figure of merit is an integral of the transient voltage with time. Also called glitch charge or glitch impulse.
- GPIB.** Abbreviation for *General Purpose Interface Bus*, also referred to as the *IEEE-488 bus*. It is a standard for parallel interfaces.
- GROUND LOOP.** A current loop created when a signal source and a signal measurement device are grounded at two separate points on a ground bus through which noise currents and/or currents from other devices flow. These currents generate voltage drops between the two ground connection points, which can cause errors and noise in the signal measurement.
- GROUND.** A common reference point for an electrical system.
- GUARDING.** A technique that reduces leakage errors and decreases response time. Consists of a guard conductor driven by a low impedance source surrounding the lead of a high impedance signal. The guard voltage is kept at or near the potential of the signal.
- HARDWARE.** The physical parts of a computer-controlled system, such as circuit boards, chassis, peripheral devices, cables, etc.
- HARMONICS.** Signal components in a waveform that occur at integer multiples of the fundamental frequency. In electronic circuits, harmonics are usually caused by nonlinearity.
- HEAT SINK.** A part used to absorb heat.
- HOT JUNCTION.** The junction of two dissimilar metals in a thermocouple circuit that is used to measure an unknown temperature. Also known as measurement junction.
- IEEE.** Abbreviation for *Institute of Electrical and Electronics Engineers*.
- IEEE-488.** See GPIB.
- IMPEDANCE.** The reciprocal of admittance. Admittance is the complex ratio of the voltage across divided by the current flowing through a device, circuit element, or network.

**INPUT BIAS CURRENT.** The current that flows at the input of an analog measurement circuit due to internal circuitry and bias voltage. Also, at conditions of zero input signal and offset voltage, the current that must be supplied to the input-high measuring terminal to reduce the output indication to zero. The input bias current is drawn through the source resistance of a signal source. Therefore, in critical and/or low-level measurements, bias current compensation or attention to source resistance may be required to minimize errors.

**INPUT IMPEDANCE.** The shunt resistance and capacitance (or inductance) as measured at the input terminals, not including effects of input bias or offset currents.

**INPUT ISOLATION.** On a switching card, the isolation between signal high to low (or guard) for a two-pole circuit. Specified as resistance and capacitance.

**INPUT OFFSET CURRENT.** The difference between the two currents that must be supplied to the input measuring terminals of a differential instrument to reduce the output indication to zero (with zero input voltage and zero offset voltage).

**INPUT OFFSET VOLTAGE.** The voltage that must be applied directly between the input measuring terminals, with bias current supplied by a resistance path, to reduce the output indication to zero.

**INPUT/OUTPUT (I/O).** The process of transferring data to and from a computer-controlled system using its communication channels, operator interface devices, data acquisition devices, or control interfaces. Also refers to the electrical inputs and outputs for data signals.

**INPUT/OUTPUT PORT.** A channel through which data is transferred between an input or output device and the processor.

**INSERTION LOSS.** The attenuation of signals caused by routing them through a switching card or other intermediate circuit element. Specified as a decibel value over a frequency range.

**INSTRUMENTATION AMPLIFIER.** A high performance differential amplifier having high input impedance at both the input high and input low terminals and typically characterized by high common mode rejection ratio (CMRR) and low drift. *See also* DIFFERENTIAL AMPLIFIER, DIFFERENTIAL INPUT, DRIFT, *and* COMMON MODE REJECTION RATIO (CMRR).

- INSULATION RESISTANCE.** The ohmic resistance of insulation. Insulation resistance can degrade quickly as humidity increases.
- INSULATOR.** A material that does not significantly conduct electrical current. Insulators have wider bandgaps than semiconductor materials.
- INTEGRAL LINEARITY.** *See* LINEARITY.
- INTEGRATION CONVERSION.** An analog to digital conversion process where the output results in a digital representation of the integral of the input signal over a specified time interval.
- INTERNAL PACER CLOCK.** *See* PACER CLOCK.
- INTERNAL TRIGGER.** A software-generated event that starts an operation. *See also* EXTERNAL TRIGGER.
- INTERRUPT LEVEL.** A method of assigning priority to hardware interrupts so that high priority tasks interrupting a system (or CPU) can be serviced before lower priority tasks.
- INTERRUPT SERVICE ROUTINE (ISR).** A software program that handles interrupts.
- INTERRUPT.** For a data acquisition board, a signal to the CPU indicating that the board detected a condition or event calling for special processing. An interrupt causes the CPU to temporarily stop the current processing task, complete the special processing task, and then return to the original processing task. *See also* INTERRUPT LEVEL, INTERRUPT-MODE OPERATION, *and* INTERRUPT SERVICE ROUTINE (ISR).
- INTERRUPT-MODE OPERATION.** Mode in which a data acquisition board acquires or generates samples using an Interrupt Service Routine (ISR). *See also* OPERATION MODES.
- ISA Bus.** Industry Standard Architecture. A PC bus architecture (8 or 16 bits wide) used in most MS-DOS and Windows computers. Sometimes called the AT bus. ISA bus PCs offer eight parallel channels for DMA mode data transfers. Replaced by the PCI bus. Also called *DMA levels*. *See also* DMA MODE.
- ISOLATED OUTPUTS.** Output signals where a common reference is not connected to either input terminal.
- JITTER.** The short-term variation of timed events. *See* APERTURE JITTER, TIMING JITTER, *and* TRIGGER JITTER.



**KELVIN CONTACTS.** A means for testing or making measurements in electronic devices and circuits, particularly when low values are being measured. Two sets of leads are used at each test point, similar with respect to thickness, material and length; one set carries the test signal and the other connects with the measuring instrument. The effect of resistance in the leads is thus eliminated.

**LATENCY.** The time required by a system to begin to acknowledge an event.

**LCZ METER.** Inductance (L), capacitance (C), impedance (Z) meter. A general-purpose instrument for measuring component L, C, and Z. Sometimes called LCR meter. This instrument may be applied to C-V testing, but typically lacks features optimized for C-V. *See* C-V METER.

**LEAKAGE CURRENT.** Any unwanted current that flows when test voltage is applied. The ideal leakage current is zero. Leakage currents can originate in instruments, cables, or the device being tested. Even high resistance paths between low current conductors and nearby voltage sources can generate significant leakage currents.

**LEAST SIGNIFICANT BIT (LSB).** The lowest order bit, usually the rightmost bit, in the binary representation of a digital quantity. Measurement precision or accuracy is sometimes specified in terms of multiple Least Significant Bits (LSBs). In that case, the precision or accuracy is represented by the binary number that results from counting the specified number of least significant bits.

**LINEARITY.** For a curve relating instrument readings to known inputs, the maximum deviation of readings from a straight line drawn between readings at zero and full range.

**LOCAL BUFFER.** Temporary memory location within an application program's memory area. It is always available to the application program. *See also* BUFFER MEMORY.

**LONG-TERM ACCURACY.** The limit that errors will not exceed during a 90-day or longer time period. It is expressed as a percentage of reading (or sourced value) plus a number of counts over a specified temperature range.

**LSB.** *See* LEAST SIGNIFICANT BIT.

**LSTTL.** Schottky-clamp TTL logic typically using one-third the power of TTL, but maintaining TTL speeds. *See also* TTL.

- MAINFRAME.** A self-contained instrument in a cabinet, which provides a measurement or connection capability without requiring other instruments in the circuit. Some mainframes may be designated as a “master” or “slave.” *See also* SWITCHING MAINFRAME, MASTER, *and* SLAVE.
- MAKE-BEFORE-BREAK.** Connecting a new circuit before disconnecting the present circuit.
- MAP.** Any representation of the structure of an object. For example, a memory map describes the layout of objects in an area of memory, and a symbol map lists the association between symbol names and memory addresses in a program.
- MASTER.** A mainframe that has control of other mainframes (slaves) through an external connection. A slave unit adds capacity or functions to the master. The master/slave combination has one IEEE-488 bus address. *See also* SLAVE *and* MAINFRAME.
- MATRIX CARD.** A type of card with a switching configuration that has columns and rows of relay crosspoints. (Also called a *coordinate switch*.) A matrix card supports simultaneously connection of one input to multiple outputs, multiple inputs to one output, or multiple inputs to multiple outputs.
- MAXIMUM ALLOWABLE INPUT.** The maximum DC plus peak AC value (voltage or current) that can be applied between the high and low input measuring terminals without damaging the instrument.
- MERCURY WETTED RELAY.** A reed relay in which the contacts are wetted by a film of mercury. Usually has a required operating position to avoid liquid mercury shorting the contacts; other types are position insensitive.
- MICRON.** A unit of length equal to  $10^{-6}$  meters. Also called a micrometer. There are 1000 microns per millimeter.
- MULTIPLEX.** Connecting one instrument to multiple devices under test or multiple instruments to one device under test. *See also* SCAN.
- MULTIPLEXER (MUX).** A circuit that switches multiple signals into one input, one signal at a time in a specified sequence.
- MULTIPLEXING.** A technique whereby multiple signals are sent to one input, one signal at a time in a specified sequence.
- MUX.** *See* MULTIPLEXER.
- NANOVOLTMETER.** A sensitive DC voltmeter (typically one decade more sensitive than a digital multimeter) with a low thermal input connection.

- NEGATIVE-EDGE TRIGGERING.** Digital trigger mode in which the triggering action starts on the falling edge of the signal. *See also* TRIGGER POLARITY *and* DIGITAL TRIGGER.
- NIBBLE.** A group of four bits or half a byte.
- NOISE.** An undesirable electrical signal from an external source such as an AC power line, motors, generators, transformers, fluorescent lights, CRT displays, computers, radio transmitters, and others.
- NORMAL MODE REJECTION RATIO (NMRR).** The ability of an instrument to reject interference (usually of line frequency) across its input terminals. Usually expressed in decibels at a frequency.
- NORMAL MODE VOLTAGE.** A voltage applied between the input high and input low terminals of an instrument.
- OBJECT LINKING AND EMBEDDING (OLE).** A Microsoft Windows standard mechanism for embedding one program within another. For example, an Excel spreadsheet can be pasted into a Visual Basic program. If a file is linked to an OLE control, the data stored in that file is displayed in the OLE control.
- OCX.** Abbreviation for *OLE Custom Control*. Also referred to as ActiveX control. Software modules packaged as OCX are usable from a variety of programming languages.
- OFFSET CURRENT.** A current that comes from a switching card even though no user signals are applied. It comes mostly from the finite coil to contact impedance. It is also generated by triboelectric, piezoelectric, and electrochemical effects present on the card.
- OFFSET VOLTAGE.** An error voltage that appears in series with an analog input terminal of a data acquisition board and is generated by the input circuits of the board.
- OLE.** Abbreviation for *Object Linking and Embedding*.
- OPERATING SYSTEM.** Base-level software that organizes the computer's resources and capabilities, runs application programs, interacts with users, and communicates with installed and peripheral devices. Popular operating systems include DOS, Windows, OS/2, and UNIX.
- OPERATION MODES.** Refers to single, synchronous, interrupt, DMA, and on-board memory (OBM) operations. *See also* DMA MODE *and* INTERRUPT-MODE OPERATION.
- OPERATION MODES.** Refers to single, synchronous, interrupt, DMA, and on-board memory (OBM) operations. *See also* DMA MODE *and* INTERRUPT-MODE OPERATION.
- OVERLOAD PROTECTION.** A circuit that protects an instrument against excessive current at the input terminals.

- PACED MODE.** A data-acquisition analog-to-digital conversion mode in which one sample is converted following each pulse of a pacer clock. That is, the conversion rate equals the pacer clock rate. *See also* PACER CLOCK, CONVERSION RATE, SAMPLE RATE, *and* ANALOG-TO-DIGITAL CONVERTER.
- PACER CLOCK RATE.** The rate at which timing pulses are emitted from a pacer clock. *See also* PACER CLOCK *and* PACED MODE.
- PACER CLOCK.** An on-board or external clock that paces or times events such as analog-to-digital conversions, digital-to-analog conversions, data sampling, interrupt generation, digital I/O transfers, etc.
- PARAMETRIC TESTS.** Tests that measure DC conditions of a chip, such as maximum current, leakage, and output drive.
- PASS-THROUGH MODE.** *See* TARGET MODE.
- PATH ISOLATION.** On a matrix switching card, the isolation from signal high and low of one path to signal high and low of any other path. Specified as *resistance* and *capacitance*. *See also* CHANNEL ISOLATION.
- PATH RESISTANCE.** On a matrix switching card, the resistance per conductor of a closed path, including the tape resistance and connector terminal resistance. *See also* CONTACT RESISTANCE.
- PATH.** One of many signal paths on a matrix switching card. A path is established by the actuation of a relay at a row and column crosspoint. *See also* CHANNEL.
- PC.** Abbreviation for *Personal Computer*.
- PCI.** Abbreviation for *Peripheral Component Interconnect*. It is a standard for a personal computer local bus. Compared to the older ISA bus, PCI offers higher speed and improved bus arbitration.
- PCMCIA.** Abbreviation for *Personal Computer Memory Card International Association*. This organization establishes standards for removable function boards for computers. PCMCIA was originally conceived for adding memory, but now includes a broad range of functions, including modems, communication interfaces, storage and data acquisition boards.
- PEAK RESPONDING.** A measurement where the displayed value is equal to the peak value of the input signal.
- PEAK.** The highest magnitude, either positive or negative. *See also* PEAK-TO-PEAK.
- PEAK-TO-PEAK.** The difference between the minimum value and maximum value of an alternating signal.
- PER CHANNEL RATE.** The sample rate for each channel of a scanning A/D system.
- PGIA.** *See* INSTRUMENTATION AMPLIFIER.

- PICOAMMETER.** A measuring instrument that is similar in function to the ammeter of an electrometer. However, a picoammeter generally provides voltage burden that is as low or lower than the ammeter of an electrometer, faster readings, and less sensitivity.
- PLUG AND PLAY.** A set of specifications developed by Intel that allows a PC to configure itself automatically to work with peripherals such as monitors, modems, and printers. A user can “plug” in a peripheral and “play” it without manually configuring the system. The PC requires both a BIOS that supports Plug and Play and a Plug and Play expansion card.
- PNP.** *See* PLUG AND PLAY.
- P-N-P.** A type of bipolar transistor junction. Opposite of N-P-N.
- POLARITY MODE.** The mode that specifies whether a data acquisition channel inputs or outputs both positive and negative signals (bipolar mode) or only positive signals (unipolar mode) relative to analog ground. *See also* BIPOLAR *and* UNIPOLAR.
- POLE.** A combination of mating relay contacts: normally open, normally closed, or both.
- PORT GROUP.** For digital I/O emulating the I/O of an 8255 programmable peripheral interface chip, a group of three 8-bit ports, commonly labeled PA, PB, and PC. Digital I/O that emulates multiple 8255 chips is typically divided into multiple port groups.
- PORT I/O CALL.** A software program statement that assigns bit values to an I/O port or retrieves bit values from an I/O port. Examples include a C/C++ statement containing an `inp` or `outp` function or a BASIC statement containing a `PEEK` or `POKE` function.
- Port.** *See* INPUT/OUTPUT PORT.
- POSITIVE-EDGE TRIGGERING.** A digital trigger mode in which the triggering action starts on the rising edge of the signal. *See also* TRIGGER POLARITY *and* DIGITAL TRIGGER.
- POST-TRIGGER ACQUISITION MODE.** A data acquisition triggering mode in which the data acquisition starts after an internal or external trigger event and continues until a specified number of samples has been acquired or until the operation is stopped by software. *See also* TRIGGER (DATA ACQUISITION) *and* TRIGGER MODES.
- P-P.** *See* PEAK-TO-PEAK.

- PRE-TRIGGER ACQUISITION MODE.** A data acquisition triggering mode in which the data acquisition is started before an internal or external trigger occurs, and stops when the trigger occurs. *See also* TRIGGER (DATA ACQUISITION) *and* TRIGGER MODES.
- PROGRAMMABLE GAIN INSTRUMENTATION AMPLIFIER (PGIA).** *See* INSTRUMENTATION AMPLIFIER.
- PROGRAMMED I/O.** A standard method of accessing an I/O device—the CPU reads each byte of data from or writes each byte of data to the device, with no external timing interrupts.
- PSEUDO-SIMULTANEOUS SAMPLE AND HOLD.** Emulating Simultaneous Sample and Hold (SSH) by scanning a group of data acquisition channels at the highest practical rate while repeating scans at a much slower rate. This is commonly done in the burst data-conversion mode, by running the burst clock at a rate close to maximum throughput while running the pacer clock at a much slower rate. Typically used when multiple parameters must be compared at essentially the same instant in time but slight timing variations are acceptable. *See also* BURST CLOCK, BURST CONVERSION MODE, PACER CLOCK, SIMULTANEOUS SAMPLE AND HOLD (SSH), SCAN (DATA ACQUISITION), *and* THROUGHPUT.
- PSEUDO-SSH.** *See* PSEUDO-SIMULTANEOUS SAMPLE AND HOLD.
- PULSE DURATION.** *See* PULSE WIDTH.
- PULSE WIDTH.** The time interval between the rising and falling edges of a pulse, specified at a certain percentage of the peak amplitude—commonly 50% for a rectangular pulse. Also referred to as pulse duration.
- QRAM.** Queue RAM. Onboard memory on a data acquisition board that holds information about the channel number and gain, and sometimes other settings, for each position in the channel-gain queue. *See also* CHANNEL-GAIN QUEUE.
- QUANTIZATION.** A process where the continuous range of values of an input signal is divided into non-overlapping sub-ranges and, to each sub-range, a discrete value of the output is uniquely assigned.
- RANGE.** A continuous band of signal values that can be measured or sourced. In bipolar instruments, range includes positive and negative values.
- RATED ACCURACY.** The limit that errors will not exceed when the instrument is used under specified operating conditions. It is expressed as a percentage (of input or output) plus a number of counts. *See also* ABSOLUTE ACCURACY.
- RATIO MEASUREMENT.** The measurement of a signal input with relation to an external reference input.

**READING RATE.** The rate at which the displayed number is updated.

**READING.** The displayed number that is proportional to the measured magnitude of the input signal.

**REAL TIME.** A property of an event or system in which data is processed as it is acquired instead of being accumulated and processed at a later time.

**REAL-TIME PROCESSING.** A technique where events occur within the required time interval.

**REGISTER.** A set of bits of high speed memory within a microprocessor or other electronic device used to hold data for a particular purpose. On data acquisition boards, any of the data or control registers that are generally accessible from the computer through I/O or memory reads and writes.

**REGISTER LEVEL PROGRAMMING.** A type of low-level programming performed through direct manipulation of the hardware's data and control registers, as opposed to programming through high-level program calls.

**RELAY MUST-OPERATE VALUE.** A specified functioning value (typically, the coil voltage) at which all relays meeting the specifications must operate. Also known as *relay pick-up* or *pull-in value*.

**RELAY MUST-RELEASE VALUE.** A specified functioning value (typically, the coil voltage) at which all relays meeting the specifications must release. Also known as *relay drop-out value*.

**RELEASE TIME.** The time between the removal of the relay coil voltage and the stabilized opening of the relay contacts.

**RELIABILITY.** The ability of a device to perform within the desired range over a measured period of time.

**REPEATABILITY.** The ability of an instrument to measure the same input to the same value, defined over a short period of time and over a narrow temperature range.

**RESISTANCE INSERTION.** A current measuring technique where a known resistor is connected in series with the circuit to be measured. The voltage drop across the resistor is proportional to the unknown current.

**RESOLUTION.** The smallest increment of a signal that can be measured, sourced, or displayed. Also called sensitivity or minimum resolvable quantity. For a digitized signal, resolution is typically expressed in bits or digits. By contrast, sensitivity is expressed in engineering units.

**RESPONSE TIME.** For a measuring instrument, the time between application of a step input signal and the indication of its magnitude within a rated accuracy. For a sourcing instrument, the time between a programmed change and the availability of the value at its output terminals. Also known as *Settling Time*.

**RINGING (IN DIGITAL-TO-ANALOG CONVERTER).** A transient oscillation in the output of a Digital-to-Analog Converter (DAC) that follows an abrupt change in input, analogous to the decaying vibrations of a clapped bell. Susceptibility to ringing in a DAC is caused by excessive capacitance in the driven load.

**RISE TIME.** The time required for a signal to change from a small percentage (usually 10%) to a large percentage (usually 90%) of its peak-to-peak amplitude. *See also* FALL TIME.

**RMS.** *See* ROOT-MEAN-SQUARE (RMS).

**RMS RESPONDING.** A measurement where the displayed value is equal to the root-mean-square (rms) of the input signal, for all input waveforms having components within the specified frequency range and crest factor limit. *See also* CREST FACTOR.

**ROOT-MEAN-SQUARE (RMS).** For an alternating signal, RMS equals the square root of the time average of the square of that signal. A sinusoidal alternating current having a particular rms value and a DC current having that same value produce the same joule heating when connected to a given resistor.

**ROW.** As viewed on the schematic of a matrix relay card, the horizontal signal lines or a horizontal group of relays.

**S.** Abbreviation for the *Sample* or *Samples* unit. *See* SAMPLE (DATA ACQUISITION).

**SAMPLE (DATA ACQUISITION).** A single value that is read from or written to one channel. *See also* CHANNEL.

**SAMPLE AND HOLD (SH).** An operation, or electronic circuit, in which an analog input signal is stored briefly as a voltage on a capacitor, typically until it can be digitized by an analog-to-digital converter.

**SAMPLE RATE.** The rate at which a continuous-time signal is sampled. It is frequently expressed as samples/second (S/s), kilosamples/second (kS/s), or megasamples/second (MS/s).



**SAMPLING ANALOG-TO-DIGITAL CONVERTER.** An analog-to-digital converter containing a sample-and-hold circuit at the front end, which captures the incoming analog signal and holds it for the duration of the analog-to-digital conversion process. *See also* ANALOG-TO-DIGITAL CONVERTER and SAMPLE-AND-HOLD (SH).

**SATURATION (AMPLIFIER).** Amplifier condition in which an increase of the input signal produces no further increase in the output signal.

**SCADA.** Supervisory Control and Data Acquisition. A type of architecture in control systems.

**SCAN (DATA ACQUISITION).** Sample a group of channels once at the acquisition or burst-mode rate; also can refer to a group of channels. These channels may be sequential (start to stop channel specified) or nonsequential (channel-gain queue used). *See also* MULTIPLEX.

**SCAN RATE.** The rate at which a group of channels is sampled, as measured from the start of one scan to the start of the next scan.

**SCATTER-GATHER.** A very high speed, direct memory access data transfer method under PCI bus mastering. Data written to memory may be “scattered” into noncontiguous memory blocks. When reading data, the memory block locations are first supplied to the bus master, and then data is rapidly “gathered” from the noncontiguous memory blocks.

**SCSI.** Small Computer System Interface. This is a standard interface that supports up to seven devices.

**SENSITIVITY.** *See* RESOLUTION.

**SERIES RC MODEL.** Interpretation of the real and imaginary components of admittance measured by a capacitance meter as resistance in series with capacitance.

**SETTLING TIME.** For a measuring instrument, the time between application of a step input signal and the indication of its magnitude within a rated accuracy. For a sourcing instrument, the time between a programmed change and the availability of the value at its output terminals. For a switching card, the time required for establishing relay connections and stabilizing user circuits. Also known as *Response Time*.

**SH.** *See* SAMPLE AND HOLD.

- SHIELDING.** A metal enclosure for the circuit being measured or a metal sleeve surrounding wire conductors (coax or triax cable) to lessen interference, interaction, or current leakage. The shield is usually grounded.
- SHORT-TERM ACCURACY.** The limit that errors will not exceed during a 24-hour period of continuous operation. Unless specified, no zeroing or adjustments of any kind are permitted. It is expressed as a percentage of reading (or sourced value) plus a number of counts over a specified temperature range.
- SIGNAL/NOISE RATIO.** The ratio of the maximum signal that can be measured to the level detected with no signal present (noise level). It is expressed in decibels. A figure of merit for characterizing how noise-free a system is.
- SIMULTANEOUS SAMPLE AND HOLD.** Operation in which the analog input channels are sampled at the same time and the values held until sequentially read by a scanning A/D system.
- SINGLE-ENDED INPUT.** The condition where the low terminal of a two-terminal instrument is connected to a specific reference point, such as power line common, earth ground, or circuit common. All signals must therefore be measured against the same reference. *See also* DIFFERENTIAL INPUT.
- SLAVE.** A mainframe that is externally connected to a controlling mainframe (master). A slave unit adds capacity or functions to the master. *See also* MASTER *and* MAINFRAME.
- SLEW RATE.** The maximum charge rate of the signal sampling capacitor in the sample and hold circuit of an A/D converter. It is expressed in volts/microsecond.
- SMALL SIGNAL LEVEL.** The amplitude of AC test signal voltage producing a linear response of the device under test. In other words, within the small signal range, the shape of the device response curve can be assumed to be linear without distorting the results.
- SOFTWARE TRIGGER.** A programmed event that starts an operation such as data acquisition.
- SOURCE IMPEDANCE.** The combination of resistance and reactance that a source presents to the input terminals of a measuring instrument.
- SOURCE TERMINAL.** Along with the gate and drain, one of the three terminals of a field-effect transistor (FET). The low impedance path through a turned-on FET is through the source and drain terminals. The gate is a high impedance, voltage-controlled input.

- SOURCE-MEASURE UNIT (SMU).** An electronic instrument that sources and measures DC voltage and current. Standard modes of operation include source voltage and measure current or source current and measure voltage. Also known as a source/monitor unit or a stimulus/measurement unit.
- SPECTRAL PURITY.** A description of the distortion components of an oscillator's output signal at a specified amplitude and load. Includes total harmonic distortion, harmonics, and spurious components.
- SPURIOUS COMPONENTS.** Undesired signals in the output of a signal generator that have a defined amplitude and frequency. They are not harmonically related to the fundamental frequency. Specified as decibels below the carrier frequency.
- SSH.** *See* SIMULTANEOUS SAMPLE AND HOLD (SSH).
- STAIRCASE WAVEFORM.** A waveform in which the voltage is incremented in uniform steps from the start voltage to the stop voltage.
- STANDOFF POTENTIAL.** The breakdown voltage across relay contacts.
- STRESS GRADIENT.** Stress gradients are produced between layers due to different thermal coefficients of expansion between the layers.
- STROBE.** A timing signal that initiates and coordinates the passage of data, typically through an input or output device interface.
- SUBROUTINE.** A set of software instructions invoked by a single calling line of code.
- SWITCH CARD.** A type of card with independent and isolated relays for switching inputs and outputs on each channel.
- SWITCHED CURRENT.** The maximum current level that can be reliably handled while opening and closing contacts. *See also* CARRY CURRENT.
- SWITCHING MAINFRAME.** A switching instrument that operates according to user commands to connect signals among sourcing and measuring instruments and devices under test. A mainframe is also referred to as a scanner, multiplexer, matrix, or programmable switch.
- SYNCHRONOUS.** In hardware, an event that occurs in a fixed time relationship to another event. In software, a function that begins an operation and returns to the calling program only when the operation is complete.

- TARGET MODE.** A PCI bus mode in which data from a data acquisition board is transferred indirectly to the computer memory in the foreground, via the host computer CPU, instead of directly, via bus mastering. Sometimes referred to as pass-through operation. *See also* BUS MASTERING *and* FOREGROUND TASK.
- TEMPERATURE COEFFICIENT OF RESISTANCE.** The amount of resistance change of a material per degree of temperature change.
- TEMPERATURE COEFFICIENT.** A change in reading (or sourced value) with a change in temperature. It is expressed as a percentage of reading (or sourced value), plus a number of counts per degree change in temperature.
- TERMINATION MODE.** Refers to the mode in which a user connects signals to the multiplexer—and, internally, to the differential amplifier—of a data acquisition board. The choices are single-ended mode or differential mode. *See also* SINGLE-ENDED INPUT (DATA ACQUISITION) *and* DIFFERENTIAL INPUT.
- THERMOELECTRIC EMFs.** Temperature-dependent voltages that develop across junctions of dissimilar metals.
- THERMOCOUPLE.** A temperature sensor created by joining two dissimilar metals. This junction creates a small voltage as a function of the temperature.
- THERMOELECTRIC VOLTAGE.** Voltages resulting from temperature differences within a measuring circuit or when conductors of dissimilar materials are joined together. Also known as *thermoelectric EMF* or *thermal offset*. *See* CONTACT POTENTIAL.
- THRESHOLD VOLTAGE ( $V_T$ ).** The voltage needed to turn on a device or initiate a process.
- THROUGHPUT.** The maximum rate at which a data conversion system can perform repetitive conversions within a specified accuracy. It is determined by summing the various times required for each part of the conversion system and then taking the inverse of this time. The throughput rate takes into account the total time required to process a signal and store the value in either on-board or system memory.
- TIMEBASE ACCURACY.** A measure of how closely the internal timebase of an instrument tracks a known time standard.
- TIMING JITTER.** The short-term variation of the time period between sample points.
- TOTAL HARMONIC DISTORTION.** The percentage of harmonic distortion present in an output signal over a specified frequency range.

**TRANSCONDUCTANCE.** The ratio of the incremental change in the output current of any amplifying circuit or device to the incremental change of input voltage causing it, when the output voltage is held constant.

**TRANSFER RATE.** The rate at which data is transferred to or from memory.

**TRANSISTOR.** A semiconductor device in which a small control signal is used to control a larger current flow.

**TRAP ( $\nu$ ).** To intercept an action or event before it occurs, usually in order to do something else. Trapping is commonly used by debuggers to allow interruption of program execution at a given spot.

**TRIGGER.** An event that starts or stops an operation. A trigger can be a specific analog, digital, or software condition. *See also* ANALOG TRIGGER *and* DIGITAL TRIGGER.

**TRIGGER CONDITIONS.** Refers to trigger sensitivity, polarity, etc.

**TRIGGER HYSTERESIS.** Applies only to analog triggers. A specified voltage change, opposite in polarity to the trigger polarity, through which an analog trigger signal must move before triggering can occur. For positive-edge triggering to occur, the signal must first fall below the specified trigger voltage by at least the amount of the hysteresis value. For negative-edge triggering to occur, the

signal must rise above the specified trigger voltage level by at least the amount of the hysteresis value. Trigger hysteresis helps prevent false triggering due to noise. *See also* ANALOG TRIGGER *and* TRIGGER POLARITY.

**TRIGGER JITTER.** The short-term variation of the time period between a trigger event and the first sample point. *See also* TRIGGER LATENCY.

**TRIGGER LATENCY.** The fixed time offset between the trigger event and the first sample point.

**TRIGGER MODE.** Refers to when data acquisition begins and ends in relation-ship to the trigger. Trigger modes include normal-trigger, pre-trigger, about-trigger, post-trigger, trigger-to-trigger, and trigger-to-about-trigger. *See also* PRE-TRIGGER ACQUISITION MODE, ABOUT-TRIGGER ACQUISITION MODE, *and* POST-TRIGGER ACQUISITION MODE

**TRIGGER POLARITY.** For edge-sensitive triggers: trigger polarity defines whether the trigger occurs when the signal is rising (positive direction) or falling (negative direction). For level-sensitive triggers: trigger polarity defines whether the trigger occurs when the signal is above a level (positive) or below a level (negative).

- TRIGGER SENSITIVITY.** Refers to edge and/or level of a trigger. For analog triggers, trigger sensitivity defines whether the trigger occurs on a transition across a specified value (edge) or whether the trigger occurs when it is above or below a specified value (level). For digital triggers, trigger sensitivity defines whether the trigger occurs on a transition from one state to another state (edge) or whether the trigger occurs when it is at a specified value (level).
- TTL.** Abbreviation for Transistor-Transistor-Logic. A popular logic circuit family that uses multiple-emitter transistors. A low signal state is defined as a signal 0.8V and below. A high signal state is defined as a signal +2.0V and above.
- TWO-TERMINAL RESISTANCE MEASUREMENT.** A measurement where the same current flows through the unknown and the test leads.
- UNIPOLAR.** An analog signal range that extends from 0, in one direction. Typically, an instrument or data acquisition board operating in unipolar mode measures a positive voltage or current starting at 0.
- USB.** Universal Serial Bus. Version 1.1 of this bus supports up to 127 peripherals and data transfer rates of up to 12MB/second; USB 2.0 offers a faster rate and other new features.
- VOLTAGE BURDEN.** The voltage drop across the resistor for the resistance insertion technique of current measurement.
- VOLTAGE STANDING WAVE RATIO (VSWR).** For a switching card, the loss due to the mismatch introduced into the signal by the card contacts and conductors. Expressed as a ratio of the highest voltage to the lowest voltage found in the signal.
- WARM-UP TIME.** The time required after power is applied to an instrument to achieve rated accuracy at referenced conditions.
- WORD.** The standard number of bits that a processor manipulates at one time. Microprocessors typically use 16-, or 32-bit words (2 bytes and 4 bytes, respectively).
- YIELD.** The ratio of good units obtained divided by the total units produced; the percent of product conforming to specifications.
- ZERO OFFSET.** The reading (desired or undesired) that occurs when the input terminals of a measuring instrument are shorted.

The glossary definitions listed here were drawn from a variety of sources, including:

ANSI C39.6-1983. American National Standard for Electrical Instrumentation. *Digital Measuring Instruments*.

American National Standards Institute, 1983.

ANSI/EIA RS-473-1981. *Definitions and Terminology for Relays for Electronic Equipment*. American National Standards Institute, 1981.

ANSI/IEEE Std. 100-1984. *IEEE Standard Dictionary of Electrical and Electronics Terms*. 3rd edition. Institute of Electrical and Electronics Engineers, 1984.

*Engineers' Relay Handbook*. 3rd edition. National Association of Relay Manufacturers, 1980.

Grove, A.S. *Physics and Technology of Semiconductor Devices*.

Horowitz, Paul and Winfield Hill. *The Art of Electronics*. 2nd edition, Cambridge University Press, 1989.

Howe, Denis, editor, *The Free On-line Dictionary of Computing*, <http://wombat.doc.ic.ac.uk/>.

Keithley Instruments, Inc. *Keithley Catalog and Reference Guide* (full line catalog), Glossary, 1998.

McGuire, Gary E., ed. *Semiconductor Materials and Process Technology Handbook*.

Microsoft Press, *Computer Dictionary*, Third Edition (ISBN: 1-57231-446-X) by Microsoft Press. Reproduced by permission of Microsoft Press.

Nicollian, E.H. and Brews, J.R., *MOS Physics and Technology*.

Parker, Sylvia P., editor. *McGraw-Hill Dictionary of Electronics and Computer Technology*. McGraw-Hill Book Company, 1984.

Schroder, Dieter K. *Semiconductor Material and Device Characterization*.

Sze, S.M. *Physics of Semiconductor Devices*.

Sze, S.M., ed. *VLSI Technology. Semiconductor Technology Handbook*. Technology Associates, 1982.

Van Zant, Peter. *Microchip Fabrication, A Practical Guide to Semiconductor Processing*.

Wolf, H.F. *Semiconductors*.

Young, E.C. *The New Penguin Dictionary of Electronics*.

All rights reserved.

---

APPENDIX C

Diameter and  
Resistance of Various  
Wire Gauges

---



The following table provides resistance data for a range of pure copper wire sizes that may be encountered in test and measurement applications. These values may vary slightly from the resistance of specific cable samples.

*AWG Wire Sizes*

<b>AWG</b>	<b>Diameter (in.)</b>	<b>Resistance (<math>\Omega</math>/1000 ft.)</b>	<b>Resistance (<math>\Omega</math>/foot)</b>
46	0.0016	4207	4.2070
44	0.0020	2592	2.5920
42	0.0024	1660	1.6600
41	0.0028	1323	1.3230
40	0.0031	1080	1.0800
39	0.0035	847	0.8470
38	0.0039	648	0.6480
37	0.0043	512	0.5120
36	0.0051	415	0.4150
35	0.0055	331	0.3310
34	0.0063	261	0.2610
33	0.0071	206	0.2060
32	0.0079	162	0.1620
30	0.0098	104	0.1040
28	0.0130	65.4	0.0654
27	0.0142	51.5	0.0515
26	0.0161	41.0	0.0410
25	0.0177	32.4	0.0324
24	0.0201	25.7	0.0257
22	0.0252	16.2	0.0162
20	0.0319	10.2	0.0102
18	0.0402	6.40	0.0064
16	0.0508	4.00	0.0040
14	0.0642	2.50	0.0025
12	0.0808	1.60	0.0016
10	0.1019	1.00	0.0010
8	0.1285	0.63	0.0006
6	0.162	0.40	0.0004

### *Metric Wire Sizes*

<b>Diameter (mm)</b>	<b>Resistance (<math>\Omega</math>/km)</b>	<b>Resistance (<math>\Omega</math>/m)</b>
0.05	8740	8.740
0.08	3414	3.414
0.14	1115	1.115
0.25	350.0	0.350
0.34	189.0	0.189
0.38	151.0	0.151
0.50	87.40	0.087
0.75	38.40	0.038
1.00	21.90	0.0219
1.50	9.710	0.0097
2.50	3.500	0.0035
4.00	1.370	0.0014

### *Approximate Correspondence of Metric Wire Sizes to AWG*

<b>Metric (mm)</b>	<b>AWG</b>
0.05	44
0.08	40
0.14	35
0.25	30
0.34	27-28*
0.38	26-27*
0.5	24
0.75	20-22*
1.0	18
2.5	10
4.0	6

\*Metric size is approximately equidistant from nearest AWG sizes.



---

APPENDIX D

Safety  
Considerations

---

## Test System Safety

Many electrical test systems or instruments are capable of measuring or sourcing hazardous voltage and power levels. It is also possible, under single fault conditions (e.g., a programming error or an instrument failure), to output hazardous levels even when the system indicates no hazard is present.

These high voltage and power levels make it essential to protect operators from any of these hazards at all times.

Protection methods include:

- Design test fixtures to prevent operator contact with any hazardous circuit.
- Make sure the device under test is fully enclosed to protect the operator from any flying debris.
- Double insulate all electrical connections that an operator could touch. Double insulation ensures the operator is still protected, even if one insulation layer fails.
- Use high-reliability, fail-safe interlock switches to disconnect power sources when a test fixture cover is opened.
- Where possible, use automated handlers so operators do not require access to the inside of the test fixture or have a need to open guards.
- Provide proper training to all users of the system so they understand all potential hazards and know how to protect themselves from injury.

**CAUTION:** During power-up, the states of board outputs are uncontrolled until hardware and software initialization has been completed. Users must make sure their designs can tolerate this or provide suitable interlocks to prevent dangerous voltages or actions from reaching users.

## General Safety Considerations

It is the responsibility of the test system designers, integrators, and installers to make sure operator and maintenance personnel protection is in place and effective.

The following safety precautions should be observed before using any Keithley product and any associated instrumentation. Although some instruments and accessories would normally be used with non-hazardous voltages, there are situations where hazardous conditions may be present. Keithley products are intended for use by qualified personnel who recognize shock hazards and are familiar with the safety precautions required to avoid possible injury. Read the operating information provided in each product's manual carefully before using any Keithley product.

The types of product users are:

**Responsible body** is the individual or group responsible for the use and maintenance of equipment, for ensuring that the equipment is operated within its specifications and operating limits, and for ensuring that operators are adequately trained.

**Operators** use the product for its intended function. They must be trained in electrical safety procedures and proper use of the instrument. They must be protected from electric shock and contact with hazardous live circuits.

**Maintenance personnel** perform routine procedures on the product to keep it operating, for example, setting the line voltage or replacing consumable materials. Maintenance procedures are described in the manual. The procedures explicitly state if the operator may perform them. Otherwise, they should be performed only by service personnel.

**Service personnel** are trained to work on live circuits, and perform safe installations and repairs of products. Only properly trained service personnel may perform installation and service procedures.

Exercise extreme caution when a shock hazard is present. Lethal voltage may be present on cable connector jacks or test fixtures. The American National Standards Institute (ANSI) states that a shock hazard exists when voltage levels greater than 30V RMS, 42.4V peak, or 60VDC are present. A good safety practice is to expect that hazardous voltage is present in any unknown circuit before measuring.

Users of these products must be protected from electric shock at all times. The responsible body must ensure that users are prevented access and/or insulated from every connection point. In some cases, connections must be exposed to potential human contact. Product users in these circumstances must be trained to protect themselves from the risk of electric shock. If the circuit is capable of operating at or above 1000 volts, no conductive part of the circuit may be exposed.

As described in the International Electrotechnical Commission (IEC) Standard IEC 664, these instruments are Installation Category I, and signal lines must not be directly connected to AC mains.

For rack mounted equipment in which the power cord is not accessible, in the event of fire or other catastrophic failure, the user must provide a separate power disconnect switch.

Do not connect switching cards directly to unlimited power circuits. They are intended to be used with impedance limited sources. NEVER connect switching cards directly to AC mains. When connecting sources to switching cards, install protective devices to limit fault current and voltage to the card.

Before operating an instrument, make sure the line cord is connected to a properly grounded power receptacle. Inspect the connecting

cables, test leads, and jumpers for possible wear, cracks, or breaks before each use.

For maximum safety, do not touch the product, test cables, or any other instruments while power is applied to the circuit under test. ALWAYS remove power from the entire test system and discharge any capacitors before: connecting or disconnecting cables or jumpers, installing or removing switching cards, or making internal changes, such as installing or removing jumpers.

Do not touch any object that could provide a current path to the common side of the circuit under test or power line (earth) ground. Always make measurements with dry hands while standing on a dry, insulated surface capable of withstanding the voltage being measured.

Instruments and accessories must be used in accordance with specifications and operating instructions or the safety of the equipment may be impaired.

Do not exceed the maximum signal levels of the instruments and accessories, as defined in the specifications and operating information, and as shown on the instrument or test fixture panels, or switching card.

When fuses are used in a product, replace with same type and rating for continued protection against fire hazard.

Chassis connections must only be used as shield connections for measuring circuits, NOT as safety earth ground connections.

If you are using a test fixture, keep the lid closed while power is applied to the device under test. Safe operation requires the use of a lid interlock.

If a  screw is present, connect it to safety earth ground using the wire recommended in the user documentation.

The  symbol on an instrument indicates that the user should refer to the operating instructions located in the manual.

The  symbol on an instrument shows that it can source or measure 1000 volts or more, including the combined effect of normal and common mode voltages. Use standard safety precautions to avoid personal contact with these voltages.

The **WARNING** heading in a manual explains dangers that might result in personal injury or death. Always read the associated information very carefully before performing the indicated procedure.

The **CAUTION** heading in a manual explains hazards that could damage the instrument. Such damage may invalidate the warranty.

Instrumentation and accessories shall not be connected to humans.

Before performing any maintenance, disconnect the line cord and all test cables.

To maintain protection from electric shock and fire, replacement components in mains circuits, including the power transformer, test leads, and input jacks, must be purchased from Keithley Instruments. Standard fuses, with applicable national safety approvals, may be used if the rating and type are the same. Other components that are not safety related may be purchased from other suppliers as long as they are equivalent to the original component. (Note that selected parts should be purchased only through Keithley Instruments to maintain accuracy and functionality of the product.) If you are unsure about the applicability of a replacement component, call a Keithley Instruments office for information.

To clean an instrument, use a damp cloth or mild, water based cleaner. Clean the exterior of the instrument only. Do not apply cleaner directly to the instrument or allow liquids to enter or spill on the instrument. Products that consist of a circuit board with no case or chassis (e.g., data acquisition board for installation into a computer) should never require cleaning if handled according to instructions. If the board becomes contaminated and operation is affected, the board should be returned to the factory for proper cleaning/servicing.





---

# Index

---

## A

Acceleration, 7-12 to 7-17  
Accelerometers, 7-12 to 7-17  
ActiveX(r) controls, 3-3, 3-4, 3-10, 3-11 to 3-12  
A/D (analog-to-digital) conversion, 5-2 to 5-9  
A/D converters  
  flash, 5-6 to 5-8  
  integrating, 5-6 to 5-7  
  resolution, 5-2 to 5-5  
  Sigma-Delta, 5-6 to 5-8  
  speed, 5-5 to 5-6  
  successive approximation, 5-6 to 5-7  
Aliasing and anti-aliasing filters, 4-9, 5-8 to 5-9, 7-17  
Analog isolation, 5-17  
Analog output control, 9-12 to 9-19  
API (Application Program Interface), 3-7 to 3-8, 3-10 to 3-11  
Application deployment, 3-7

## B

Base metal thermocouples, 6-10  
Battery charge/discharge testing, 9-16 to 9-18  
Bessel filter, 5-9  
Bipolar signals, 4-18  
Buffer (non-inverting digital gate), 4-21  
Burn-in testing, 9-9 to 9-11  
Bus architecture, 2-3 to 2-5  
Bus mastering, 2-3, 2-4, 3-13  
Butterworth filter, 4-20, 5-9

## C

Cables and connectors, 8-4 to 8-7

Callendar-Van Dusen coefficients, 6-17 to 6-18  
Cauer filter, 4-20, 5-9  
Capacitive reactance, 4-8 to 4-9  
Capacitors, 4-6 to 4-10, 4-14, 4-19  
CMOS (Complementary Metal Oxide Semiconductor) logic, 4-24, 5-10, 5-14  
Cold junction, 6-3  
Color codes (thermocouples), 6-10 to 6-11  
Common mode voltage, 4-16 to 4-17  
COM (Common Object Model) objects, 3-3, 3-4, 3-7, 3-10, 3-11  
Contact bounce, 5-12  
Converters (protocol or interface), 2-12 to 2-13  
Current measurements, 8-2 to 8-4  
CVD (Chemical Vapor Deposition) system control, 9-5 to 9-6

## D

D/A (digital-to-analog) conversion, 5-9 to 5-10  
Debugging, 3-7  
Deterministic data acquisition system, 3-13 to 3-14, 9-3  
Device drivers, 2-9, 2-10, 3-2, 3-3, 3-6, 3-7 to 3-15  
Differential input, 4-17 to 4-19, 8-4 to 8-5  
Digital I/O (Input/Output), 4-21 to 4-24  
Digital isolation, 5-16 to 5-17  
Discrete instruments, 1-5  
DMA (Direct Memory Access), 2-3, 2-4, 3-13

DOS (Disk Operating System),  
2-4, 3-2, 3-3, 3-4, 3-8, 3-9 to  
3-10

Drive current requirements, 5-14  
to 5-15

Dry switching, 5-13

## E

Electrical isolation, 5-15 to 5-17,  
6-10

EMI/RFI (Electromagnetic  
Interference/Radio Frequency  
Interference) radiation, 9-5

ESR (Equivalent Series  
Resistance), 4-7

Ethernet, 1-4, 2-11 to 2-13

Event-driven control, 3-6, 3-13 to  
3-14

Excitation current, 6-18

Expansion slots, 2-3, 2-4, 5-3

Extenders, 2-12 to 2-13

External data acquisition sys-  
tems, 1-3 to 1-4

## F

FIFO (First In, First Out) memo-  
ry, 3-12 to 3-13, 5-2

Filters, 4-7, 4-10, 4-15, 4-19 to  
4-21, 5-2, 6-3, 6-17, 7-10  
aliasing and anti-aliasing, 4-9,  
5-8 to 5-9, 7-17

Bessel, 5-9

Butterworth, 4-20, 5-9

Cauer, 4-20, 5-9

Chebyshev, 4-20

FireWire, 2-10 to 2-11, 3-11

Flash A/D converters, 5-6 to 5-8

Flip-flop circuit, 5-12

Flow sensors, 7-11 to 7-12

Four-wire remote sensing, 5-10,  
9-12

## G

Gauge factor, 7-6

GPIO (General Purpose Interface  
Bus), 2-8 to 2-9, 2-10, 2-11, 2-  
12, 2-13, 3-7 (*See also* IEEE-  
488)

Graphical programming, 3-4 to  
3-5

Ground loops, 4-16 to 4-17, 5-18  
to 5-19, 9-5

## H

HALT/HASS (Highly Accelerated  
Life Testing/Highly  
Accelerated Stress Screening)  
procedures, 9-9 to 9-11

Harmonics, 7-17

Hot swapping, 2-5

Hybrid data acquisition systems,  
1-5 to 1-6

Hysteresis, 5-14

## I

IEEE-488 interface, 1-5, 2-8 to  
2-9, 2-11, 2-13, 2-5, 2-7, 3-7  
(*See also* GPIO)

IEEE-1394 bus, 2-10 to 2-11 (*See  
also* FireWire)

Inductors, 4-10 to 4-11

Input accuracy, 5-5

Integra™ Series data acquisition  
systems, 1-5 to 1-6

Integrating A/D converter, 5-6 to  
5-7

Intermediate Metals, Law of, 6-5

Inverter (inverting digital gate),  
4-21

ISA (Industry Standard  
Architecture) bus, 1-3, 2-3 to  
2-4

## **J**

Joule heating, 6-18, 7-6

## **L**

Laptop computers, 2-5

Law of Intermediate Metals, 6-5

Linearization of thermocouple outputs, 6-3, 6-7 to 6-8

Load cells, 7-11 to 7-12

Look-up tables, 6-4, 6-7 to 6-8, 6-17

## **M**

Multiplexers, 5-2, 5-5, 5-6, 9-10

## **N**

Noble metal thermocouples, 6-10 to 6-12

Normal mode voltage, 4-15 to 4-16

Nyquist rate, 5-8, 7-16

## **O**

OEM (Original Equipment Manufacturer)/factory automation applications, 9-2 to 9-5

Op amp theory, 4-11 to 4-19

Open vs. closed programming environment, 3-2 to 3-7

Opto-isolators, 5-16 to 5-17

## **P**

Parallel port, 2-5, 2-8

Pass band (filter), 5-9

Passive components, 4-2 to 4-11, 4-19 to 4-20, 6-19, 7-2

PCI (Peripheral Component Interconnect) bus, 1-3, 2-3, 2-4 to 2-5, 2-8, 2-9, 3-13

PCMCIA (Personal Computer Memory Card International Association) bus, 2-5, 2-9

Personal computer

configurations for data acquisition, 2-2 to 2-3

definition, 1-2

Plug-and-Play (PnP) operation, 2-3 to 2-5, 2-10, 3-9

Plug-in data acquisition boards, 1-3 to 1-5, 3-7, 5-3, 5-4, 8-3

Poisson's ratio, 7-2 to 7-3

Polling, 3-6, 3-13 to 3-14

Pressure sensors, 7-11 to 7-12

Process monitoring, 9-6 to 9-8

Program documentation, 3-9

## **Q**

Q (parameter), 7-13 to 7-16

## **R**

RAM (Random Access Memory) requirements, 2-2

RC time constant, 4-9 to 4-10

Real-time data acquisition and control applications, 1-4 to 1-5, 3-14 to 3-15

Reference temperature sensors, 6-3

Repeaters, 2-9, 2-12 to 2-13

Resistors, 4-2 to 4-6, 4-17, 4-19 dropping, 8-2 to 8-3 load, 9-10

pull-up, 5-11

reference, 6-16

series, 9-17

shunt, 9-14, 9-16, 9-17, 9-18

Resonance, 7-13 to 7-14

Response curve or cut-off (filter), 4-20 to 4-21

RS-232, 2-5 to 2-8, 2-11, 2-13, 3-11

RS-422, 2-5 to 2-8, 2-12

RS-485, 2-5 to 2-8, 2-12  
RTDs (Resistive Temperature  
Detectors), 6-12 to 6-19  
Runtime license, 3-3

## **S**

Schmidt trigger, 5-14  
Seebeck effect, 6-3  
Semiconductor linear tempera-  
ture sensors, 6-21  
Serial ports, 2-5 to 2-8, 2-12, 2-13  
Shielding, 8-5 to 8-6, 9-5  
Shock, 7-13  
Shock absorber testing, 9-11 to  
9-12  
Shunt calibration, 7-10 to 7-11  
Sigma-Delta A/D converter, 5-6  
to 5-8  
Single-ended input, 4-17 to 4-19,  
8-4 to 8-5  
Slow moving signals, 5-13 to 5-14  
Software development under  
Windows(r), 3-7 to 3-12  
Software structure, 3-7 to 3-8  
Solenoids, 5-15  
Solid-state relays, 5-14 to 5-15  
Source resistance, 4-4 to 4-5,  
4-19, 8-4  
SourceMeter® instruments, 1-5  
Speed vs. accuracy tradeoffs,  
3-15 to 3-16, 5-8  
Steinhart-Hart equation, 6-21  
Stop band (filter), 5-9  
Strain  
    apparent, 7-7  
    definition, 7-2  
    gauges, 7-2 to 7-6, 7-7 to 7-12  
    Poisson's, 7-2  
Stress testing, 9-9 to 9-11

Successive approximation A/D  
converter, 5-6 to 5-7  
System DMA (Direct Memory  
Access), 3-13

## **T**

TCP/IP (Transmission Control  
Protocol/Internet Protocol),  
2-12  
Tensile testing, 9-8 to 9-9  
Text-based programming, 3-4 to  
3-5  
Thermal shunting, 6-21 to 6-22  
Thermistors, 6-19 to 6-21  
Thermocouples, 6-2 to 6-12  
Thermoelectric EMFs (electro-  
motive forces), 6-8, 7-6, 8-4  
TTL (Transistor-Transistor  
Logic), 4-23 to 4-24, 5-10 to  
5-11, 5-13, 5-14 to 5-15

## **U**

USB (Universal Serial Bus), 1-4,  
1-5, 2-6, 2-9 to 2-11, 3-7, 3-11  
Unipolar signals, 4-18

## **V**

Vibration, 7-13  
Voltage burden, 8-2 to 8-3

## **W**

Wheatstone bridges  
    full bridge, 7-7 to 7-8  
    half bridge, 7-8 to 7-9  
    quarter bridge, 7-9 to 7-10  
    use as strain gauges, 7-3 to  
    7-11, 7-15  
    with RTDs, 6-14, 6-16  
Windows® Messaging and Event  
Management, 3-6









Specifications are subject to change without notice.

All Keithley trademarks and trade names are the property of Keithley Instruments, Inc. All other trademarks and trade names are the property of their respective companies.

**KEITHLEY**

**Keithley Instruments, Inc.**

28775 Aurora Road • Cleveland, Ohio 44139 • 440-248-0400 • Fax: 440-248-6168  
1-888-KEITHLEY (534-8453) [www.keithley.com](http://www.keithley.com)

© Copyright 2001 Keithley Instruments, Inc.  
Printed in the U.S.A.

No. 1716  
70130KSI