

KEITHLEY

DAS-8 Series

User's Guide



A GREATER MEASURE OF CONFIDENCE

WARRANTY

Hardware

Keithley Instruments, Inc. warrants that, for a period of one (1) year from the date of shipment (3 years for Models 2000, 2001, 2002, 2010 and 2700), the Keithley Hardware product will be free from defects in materials or workmanship. This warranty will be honored provided the defect has not been caused by use of the Keithley Hardware not in accordance with the instructions for the product. This warranty shall be null and void upon: (1) any modification of Keithley Hardware that is made by other than Keithley and not approved in writing by Keithley or (2) operation of the Keithley Hardware outside of the environmental specifications therefore.

Upon receiving notification of a defect in the Keithley Hardware during the warranty period, Keithley will, at its option, either repair or replace such Keithley Hardware. During the first ninety days of the warranty period, Keithley will, at its option, supply the necessary on site labor to return the product to the condition prior to the notification of a defect. Failure to notify Keithley of a defect during the warranty shall relieve Keithley of its obligations and liabilities under this warranty.

Other Hardware

The portion of the product that is not manufactured by Keithley (Other Hardware) shall not be covered by this warranty, and Keithley shall have no duty of obligation to enforce any manufacturers' warranties on behalf of the customer. On those other manufacturers' products that Keithley purchases for resale, Keithley shall have no duty of obligation to enforce any manufacturers' warranties on behalf of the customer.

Software

Keithley warrants that for a period of one (1) year from date of shipment, the Keithley produced portion of the software or firmware (Keithley Software) will conform in all material respects with the published specifications provided such Keithley Software is used on the product for which it is intended and otherwise in accordance with the instructions therefore. Keithley does not warrant that operation of the Keithley Software will be uninterrupted or error-free and/or that the Keithley Software will be adequate for the customer's intended application and/or use. This warranty shall be null and void upon any modification of the Keithley Software that is made by other than Keithley and not approved in writing by Keithley.

If Keithley receives notification of a Keithley Software nonconformity that is covered by this warranty during the warranty period, Keithley will review the conditions described in such notice. Such notice must state the published specification(s) to which the Keithley Software fails to conform and the manner in which the Keithley Software fails to conform to such published specification(s) with sufficient specificity to permit Keithley to correct such nonconformity. If Keithley determines that the Keithley Software does not conform with the published specifications, Keithley will, at its option, provide either the programming services necessary to correct such nonconformity or develop a program change to bypass such nonconformity in the Keithley Software. Failure to notify Keithley of a nonconformity during the warranty shall relieve Keithley of its obligations and liabilities under this warranty.

Other Software

OEM software that is not produced by Keithley (Other Software) shall not be covered by this warranty, and Keithley shall have no duty or obligation to enforce any OEM's warranties on behalf of the customer.

Other Items

Keithley warrants the following items for 90 days from the date of shipment: probes, cables, rechargeable batteries, diskettes, and documentation.

Items not Covered under Warranty

This warranty does not apply to fuses, non-rechargeable batteries, damage from battery leakage, or problems arising from normal wear or failure to follow instructions.

Limitation of Warranty

This warranty does not apply to defects resulting from product modification made by Purchaser without Keithley's express written consent, or by misuse of any product or part.

Disclaimer of Warranties

EXCEPT FOR THE EXPRESS WARRANTIES ABOVE KEITHLEY DISCLAIMS ALL OTHER WARRANTIES, EXPRESS OR IMPLIED, INCLUDING WITHOUT LIMITATION, ALL IMPLIED WARRANTIES OF MERCHANTABILITY AND FITNESS FOR A PARTICULAR PURPOSE. KEITHLEY DISCLAIMS ALL WARRANTIES WITH RESPECT TO THE OTHER HARDWARE AND OTHER SOFTWARE.

Limitation of Liability

KEITHLEY INSTRUMENTS SHALL IN NO EVENT, REGARDLESS OF CAUSE, ASSUME RESPONSIBILITY FOR OR BE LIABLE FOR: (1) ECONOMICAL, INCIDENTAL, CONSEQUENTIAL, INDIRECT, SPECIAL, PUNITIVE OR EXEMPLARY DAMAGES, WHETHER CLAIMED UNDER CONTRACT, TORT OR ANY OTHER LEGAL THEORY, (2) LOSS OF OR DAMAGE TO THE CUSTOMER'S DATA OR PROGRAMMING, OR (3) PENALTIES OR PENALTY CLAUSES OF ANY DESCRIPTION OR INDEMNIFICATION OF THE CUSTOMER OR OTHERS FOR COSTS, DAMAGES, OR EXPENSES RELATED TO THE GOODS OR SERVICES PROVIDED UNDER THIS WARRANTY.

KEITHLEY

Keithley Instruments, Inc.

28775 Aurora Road • Cleveland, Ohio 44139 • 440-248-0400 • Fax: 440-248-6168
1-888-KEITHLEY (534-8453) • www.keithley.com

| | | |
|----------------|----------------|--|
| Sales Offices: | BELGIUM: | Bergensesteenweg 709 • B-1600 Sint-Pieters-Leeuw • 02-363 00 40 • Fax: 02/363 00 64 |
| | CHINA: | Yuan Chen Xin Building, Room 705 • 12 Yumin Road, Dewai, Madian • Beijing 100029 • 8610-6202-2886 • Fax: 8610-6202-2892 |
| | FINLAND: | Tietäjäntie 2 • 02130 Espoo • Phone: 09-54 75 08 10 • Fax: 09-25 10 51 00 |
| | FRANCE: | 3, allée des Garays • 91127 Palaiseau Cédex • 01-64 53 20 20 • Fax: 01-60 11 77 26 |
| | GERMANY: | Landsberger Strasse 65 • 82110 Germering • 089/84 93 07-40 • Fax: 089/84 93 07-34 |
| | GREAT BRITAIN: | Unit 2 Commerce Park, Brunel Road • Theale • Berkshire RG7 4AB • 0118 929 7500 • Fax: 0118 929 7519 |
| | INDIA: | Flat 2B, Willocrissa • 14, Rest House Crescent • Bangalore 560 001 • 91-80-509-1320/21 • Fax: 91-80-509-1322 |
| | ITALY: | Viale San Gimignano, 38 • 20146 Milano • 02-48 39 16 01 • Fax: 02-48 30 22 74 |
| | JAPAN: | New Pier Takeshiba North Tower 13F • 11-1, Kaigan 1-chome • Minato-ku, Tokyo 105-0022 • 81-3-5733-7555 • Fax: 81-3-5733-7556 |
| | KOREA: | 2FL., URI Building • 2-14 Yangjae-Dong • Seocho-Gu, Seoul 137-888 • 82-2-574-7778 • Fax: 82-2-574-7838 |
| | NETHERLANDS: | Postbus 559 • 4200 AN Gorinchem • 0183-635333 • Fax: 0183-630821 |
| | SWEDEN: | c/o Regus Business Centre • Frosundaviks Allé 15, 4tr • 169 70 Solna • 08-509 04 679 • Fax: 08-655 26 10 |
| | SWITZERLAND: | Kriesbachstrasse 4 • 8600 Dübendorf • 01-821 94 44 • Fax: 01-820 30 81 |
| | TAIWAN: | 1FL., 85 Po Ai Street • Hsinchu, Taiwan, R.O.C. • 886-3-572-9077 • Fax: 886-3-572-9031 |

DAS-8 Series User's Guide

Revision H- June 2002
Part Number: 66160

The information contained in this manual is believed to be accurate and reliable. However, Keithley Instruments, Inc., assumes no responsibility for its use; nor for any infringements or patents or other rights of third parties that may result from its use. No license is granted by implication or otherwise under any patent rights of Keithley Instruments, Inc.

KEITHLEY INSTRUMENTS, INC., SHALL NOT BE LIABLE FOR ANY SPECIAL, INCIDENTAL, OR CONSEQUENTIAL DAMAGES RELATED TO THE USE OF THIS PRODUCT. THIS PRODUCT IS NOT DESIGNED WITH COMPONENTS OF A LEVEL OF RELIABILITY THAT IS SUITED FOR USE IN LIFE SUPPORT OR CRITICAL APPLICATIONS.

All brand and product names are trademarks or registered trademarks of their respective companies.

© Copyright Keithley Instruments, Inc., 1999, 1993.

All rights reserved. Reproduction or adaptation of any part of this documentation beyond that permitted by Section 117 of the 1976 United States Copyright Act without permission of the Copyright owner is unlawful.

The following safety precautions should be observed before using this product and any associated instrumentation. Although some instruments and accessories would normally be used with non-hazardous voltages, there are situations where hazardous conditions may be present.

This product is intended for use by qualified personnel who recognize shock hazards and are familiar with the safety precautions required to avoid possible injury. Read and follow all installation, operation, and maintenance information carefully before using the product. Refer to the manual for complete product specifications.

If the product is used in a manner not specified, the protection provided by the product may be impaired.

The types of product users are:

Responsible body is the individual or group responsible for the use and maintenance of equipment, for ensuring that the equipment is operated within its specifications and operating limits, and for ensuring that operators are adequately trained.

Operators use the product for its intended function. They must be trained in electrical safety procedures and proper use of the instrument. They must be protected from electric shock and contact with hazardous live circuits.

Maintenance personnel perform routine procedures on the product to keep it operating properly, for example, setting the line voltage or replacing consumable materials. Maintenance procedures are described in the manual. The procedures explicitly state if the operator may perform them. Otherwise, they should be performed only by service personnel.

Service personnel are trained to work on live circuits, and perform safe installations and repairs of products. Only properly trained service personnel may perform installation and service procedures.

Keithley products are designed for use with electrical signals that are rated Installation Category I and Installation Category II, as described in the International Electrotechnical Commission (IEC) Standard IEC 60664. Most measurement, control, and data I/O signals are Installation Category I and must not be directly connected to mains voltage or to voltage sources with high transient over-voltages. Installation Category II connections require protection for high transient over-voltages often associated with local AC mains connections. Assume all measurement, control, and data I/O connections are for connection to Category I sources unless otherwise marked or described in the Manual.

Exercise extreme caution when a shock hazard is present. Lethal voltage may be present on cable connector jacks or test fixtures. The American National Standards Institute (ANSI) states that a shock hazard exists when voltage levels greater than 30V RMS, 42.4V peak, or 60VDC are present. **A good safety practice is to expect that hazardous voltage is present in any unknown circuit before measuring.**

Operators of this product must be protected from electric shock at all times. The responsible body must ensure that operators are prevented access and/or insulated from every connection point. In some cases, connections must be exposed to potential human contact. Product operators in these circumstances must be trained to protect themselves from the risk of electric shock. If the circuit is capable of operating at or above 1000 volts, **no conductive part of the circuit may be exposed.**

Do not connect switching cards directly to unlimited power circuits. They are intended to be used with impedance limited sources. NEVER connect switching cards directly to AC mains. When connecting sources to switching cards, install protective devices to limit fault current and voltage to the card.

Before operating an instrument, make sure the line cord is connected to a properly grounded power receptacle. Inspect the connecting cables, test leads, and jumpers for possible wear, cracks, or breaks before each use.

When installing equipment where access to the main power cord is restricted, such as rack mounting, a separate main input power disconnect device must be provided, in close proximity to the equipment and within easy reach of the operator.

For maximum safety, do not touch the product, test cables, or any other instruments while power is applied to the circuit under test. ALWAYS remove power from the entire test system and discharge any capacitors before: connecting or disconnecting cables or jumpers, installing or removing switching cards, or making internal changes, such as installing or removing jumpers.

Do not touch any object that could provide a current path to the common side of the circuit under test or power line (earth) ground. Always make measurements with dry hands while standing on a dry, insulated surface capable of withstanding the voltage being measured.



The instrument and accessories must be used in accordance with its specifications and operating instructions or the safety of the equipment may be impaired.

Do not exceed the maximum signal levels of the instruments and accessories, as defined in the specifications and operating information, and as shown on the instrument or test fixture panels, or switching card.

When fuses are used in a product, replace with same type and rating for continued protection against fire hazard.

Chassis connections must only be used as shield connections for measuring circuits, NOT as safety earth ground connections.

If you are using a test fixture, keep the lid closed while power is applied to the device under test. Safe operation requires the use of a lid interlock.

If  or  is present, connect it to safety earth ground using the wire recommended in the user documentation.

The  symbol on an instrument indicates that the user should refer to the operating instructions located in the manual.

The  symbol on an instrument shows that it can source or measure 1000 volts or more, including the combined effect of normal and common mode voltages. Use standard safety precautions to avoid personal contact with these voltages.

The **WARNING** heading in a manual explains dangers that might result in personal injury or death. Always read the associated information very carefully before performing the indicated procedure.

The **CAUTION** heading in a manual explains hazards that could damage the instrument. Such damage may invalidate the warranty.

Instrumentation and accessories shall not be connected to humans.

Before performing any maintenance, disconnect the line cord and all test cables.

To maintain protection from electric shock and fire, replacement components in mains circuits, including the power transformer, test leads, and input jacks, must be purchased from Keithley Instruments. Standard fuses, with applicable national safety approvals, may be used if the rating and type are the same. Other components that are not safety related may be purchased from other suppliers as long as they are equivalent to the original component. (Note that selected parts should be purchased only through Keithley Instruments to maintain accuracy and functionality of the product.) If you are unsure about the applicability of a replacement component, call a Keithley Instruments office for information.

To clean an instrument, use a damp cloth or mild, water based cleaner. Clean the exterior of the instrument only. Do not apply cleaner directly to the instrument or allow liquids to enter or spill on the instrument. Products that consist of a circuit board with no case or chassis (e.g., data acquisition board for installation into a computer) should never require cleaning if handled according to instructions. If the board becomes contaminated and operation is affected, the board should be returned to the factory for proper cleaning/servicing.

Preface

The *DAS-8 Series User's Guide* provides the information needed to set up, install, and use DAS-8 Series boards.

The manual is intended for data acquisition system designers, engineers, technicians, scientists, and other users responsible for setting up, cabling, and wiring signals to DAS-8 Series boards. It is assumed that users are familiar with data acquisition principles and with their particular application.

The *DAS-8 Series User's Guide* is organized as follows:

- Section 1 provides an overview of the features of DAS-8 Series boards, including a description of supported software and accessories.
- Section 2 provides a more detailed description of the analog input, digital I/O, analog output, and counter/timer I/O features of DAS-8 Series boards.
- Section 3 describes how to unpack, configure, and install DAS-8 Series boards.
- Section 4 describes how to attach accessory and expansion boards and how to wire signals to DAS-8 Series boards.
- Section 5 describes how to use DriverLINX Analog I/O Panel and DriverLINX Test Panel options to test functions of DAS-8 Series boards.
- Section 6 describes how to calibrate DAS-8 Series boards.
- Section 7 provides troubleshooting information.

- Appendix A lists the specifications for DAS-8 Series boards.
- Appendix B lists the connector pin assignments.
- Appendix C provides information for programming DAS-8 Series boards using DriverLINX.

An index completes this manual.

Throughout the manual, keep the following in mind:

- References to DAS-8 Series boards apply to the DAS-8, DAS-8/LT, DAS-8/PGA, DAS-8/PGA-G2, and DAS-8/AO boards. When a feature applies to a particular board, that board's name is used.

Table of Contents

| | |
|---|------------|
| Overview | 1-1 |
| DAS-8 Hardware | 1-1 |
| DAS-8 Software | 1-3 |
| Accessories | 1-5 |
| Functional Description | 2-1 |
| Analog Input Features | 2-2 |
| Channel Configuration | 2-3 |
| Clock | 2-10 |
| Custom Clock Frequencies | 2-10 |
| Conversion Clock Sources (DAS-8/PGA(G2), DAS-8/AO, and DAS-8/LT) | 2-11 |
| Triggers | 2-14 |
| Hardware Gates | 2-16 |
| Data Transfer | 2-18 |
| DAS-8/AO Analog Output Features | 2-18 |
| Digital I/O Features | 2-19 |
| 82C54 Counter/Timer Circuitry | 2-20 |
| Interrupts | 2-26 |
| Power | 2-27 |
| Setup and Installation | 3-1 |
| Installation Procedure | 3-1 |
| Unpacking the Board | 3-2 |
| DAS-8 Series Boards | 3-3 |

| | |
|--|------|
| Configuring the Board | 3-7 |
| Setting the Base Address | 3-8 |
| Setting the Input Configuration | 3-12 |
| Setting the Interrupt Level | 3-13 |
| Analog Output Voltage Range Adjustments (DAS-8/AO Only) | 3-14 |
| D/A Output Channel Update (DAS-8/AO Only) | 3-16 |
| Wait-State Setting (DAS-8/AO Only) | 3-16 |
| Clock Select (DAS-8/LT Only) | 3-16 |
| Clock | 3-16 |
| Custom Clock Frequencies | 3-16 |
| 4–20mA Current Loops | 3-17 |
| The Reference (DAS-8 and DAS-8/LT Only) | 3-17 |
| Interface to Transducers, Thermocouples, etc. ... | 3-18 |
| Application Precautions | 3-20 |
| Installing and Configuring DriverLINX for | |
| DAS-8 Series Boards | 3-21 |
| Installing the DAS-8 Series Standard | |
| Software Package | 3-22 |
| Installing DriverLINX | 3-24 |
| Configuration with DriverLINX | 3-25 |
| Installing the Board | 3-25 |
| Configuring DriverLINX | 3-26 |
| Editing a Configuration File | 3-28 |

| | |
|--|------------|
| Cabling and Wiring | 4-1 |
| Attaching Accessory and Expansion Boards | 4-1 |
| Attaching an STC-37 Screw | |
| Terminal Connector | 4-3 |
| Attaching an STA-08 / STA-08PGA | |
| Screw Terminal Accessory | 4-5 |
| Attaching an EXP-16 or EXP-16/A Expansion | |
| Board | 4-6 |
| Attaching an EXP-GP Expansion Board | 4-7 |
| Attaching an MB Series Backplane | 4-8 |
| Connecting Multiple Expansion Boards | 4-8 |
| Connecting Signals | 4-9 |
| Connecting an Analog Input Signal to a | |
| Single-Ended Input | 4-10 |
| Connecting an Analog Input Signal to a | |
| Differential Input | 4-11 |
| Connecting Analog Output Signal from a | |
| DAS-8/AO Board | 4-12 |
| Connecting Digital Signals | 4-13 |
| Connecting Counter/Timer I/O Signals | 4-14 |
| Synchronizing Conversions on | |
| Multiple Boards | 4-14 |
| 4–20mA Current Loops | 4-16 |
| The Reference (DAS-8 and DAS-8/LT Only) | 4-16 |

| | |
|--|------------|
| Calibration | 5-1 |
| Equipment Required | 5-1 |
| Potentiometers | 5-2 |
| Troubleshooting | 6-1 |
| Problem Isolation | 6-2 |
| Troubleshooting Table | 6-3 |
| Technical Support | 6-5 |
| Specifications | A-1 |
| DAS-8 Specifications | A-1 |
| DAS-8/PGA Specifications | A-4 |
| DAS-8/AO Specifications | A-5 |
| DAS-8/LT Specifications | A-8 |
| Connector Pin Assignments | B-1 |
| DriverLINX Implementation Notes | C-1 |
| Logical Channels | C-3 |
| Analog Input Subsystem | C-3 |
| Logical Channels | C-3 |
| Analog Input Initialization | C-3 |
| External Triggering | C-4 |
| External Clocking | C-5 |
| Data Coding | C-5 |
| A/D Conversion Delay | C-6 |
| A/D Data Lost | C-7 |
| Analog Output Subsystem | C-7 |
| Analog Output Initialization | C-7 |
| External Triggering | C-7 |
| External Clocking | C-8 |

| | |
|---|------|
| Data Coding | C-8 |
| D/A Conversion Delay | C-9 |
| D/A Data Lost | C-9 |
| Digital Input and Output Subsystems | C-10 |
| Logical Channels | C-10 |
| Digital Input Initialization | C-10 |
| Digital Output Initialization | C-10 |
| Digital I/O Conversion Delay | C-10 |
| Digital I/O Data Lost | C-10 |
| Counter/Timer Subsystem | C-11 |
| Logical Channels | C-11 |
| Counter/Timer Initialization | C-12 |
| Counter/Timer Interrupt | C-12 |
| Event Counting | C-12 |
| Frequency Measurement | C-13 |
| Pulse Output | C-14 |
| Oneshot Pulse Output | C-15 |
| Time Interval Measurements | C-15 |

Overview

DAS-8 Hardware

The DAS-8 Series consists of the DAS-8, the DAS-8LT, the DAS-8PGA and DAS-8PGA-G2, and the DAS-8AO for IBM PC and PC compatible computers. The DAS-8 boards with DriverLINX software require:

- an IBM PC or compatible AT (386, or Pentium CPU) with minimum of 2 MB of memory
- at least one CD-ROM drive, and one fixed disk drive
- MS-DOS/PCDOS 3.1 or higher
- Microsoft Windows 95/98 (**Note:** DAS-8 Series boards are **not** compatible with Windows NT).
- a compiler supporting Microsoft Windows development
- a mouse is highly recommended

Each member of the DAS-8 Series has the same functions with the following differences:

- **DAS-8/LT** — for use in a laptop or portable computer. Has 1 MHz clock for sample timing.
- **DAS-8/PGA and DAS-8/PGA-G2** — has software-programmable input ranges of $\pm 10\text{V}$, $\pm 5\text{V}$, $\pm 0.5\text{V}$, $\pm 0.05\text{V}$, $\pm 0.01\text{V}$, 0 to $+10\text{V}$, 0 to $+1\text{V}$, and 0 to $+0.02\text{V}$ (DAS-8/PGA), or $\pm 5\text{V}$, $\pm 2.5\text{V}$, $\pm 1.25\text{V}$, $\pm 0.625\text{V}$, 0 to $+5\text{V}$, 0 to $+2.5\text{V}$, 0 to $+1.25\text{V}$, and 0 to $+0.625\text{V}$ (DAS-8/PGA/G2) and each channel is switch-selectable for single-ended and differential inputs.

- **DAS-8/AO** — same as DAS-8/PGA with two 12-bit analog outputs and onboard pacer clock for sample timing.

The DAS-8 Series features an 8-channel, 12-bit successive approximation A/D converter with sample and hold. The full scale input of each channel is fixed at $\pm 5\text{V}$ on the DAS-8 and DAS-8LT and software-programmable on the DAS-8PGA and DAS-8/AO. The A/D conversion time is typically $25\mu\text{s}$ ($35\mu\text{s}$ max.). Using the DriverLINX software supplied with the board, throughputs of up to 4ksamples per second are attainable.

An onboard 82C54 programmable counter-timer provides periodic interrupts for the A/D sample timing. In the DAS-8, this timer obtains its input clock directly from the computer's ISA bus clock (usually 4.77, 6, or 8 MHz). The DAS-8/LT, DAS-8PGA, and DAS-8/AO have an onboard 1 MHz crystal. Two additional counters on the 82C54 are available for event counting, pulse and waveform generation, frequency, period, and pulse width measurements.

The 7 bits of TTL digital I/O consist of one 4-bit output port and one 3-bit input port. In addition, a precision $+10.00\text{V}$ ($\pm 0.1\text{V}$) reference voltage output is derived from the A/D converter reference. This output can source/sink 2mA.

A jumper-selectable external interrupt input selects any of the interrupt levels (2 through 7) and allows interrupt routines to provide background data acquisition or interrupt-driven control. The interrupt input can be externally connected to the counter/timer or other trigger source.

The two 12-bit analog output channels of the DAS-8/AO are independently switch-selectable to full-scale output ranges of $\pm 10\text{V}$, $\pm 5\text{V}$, $\pm 2.5\text{V}$, 0 to $+10\text{V}$, 0 to $+5\text{V}$, or 4 to 20mA. Simultaneous update of both channels is supported in DriverLINX.

DAS-8 Software

The following software is available for operating DAS-8 Series boards:

- **DAS-8 Series standard software package** — Shipped with DAS-8 Series boards. Includes DriverLINX for Microsoft Windows and function libraries for writing application programs such as Microsoft Visual C++; Microsoft Visual Basic; Borland Delphi; utility programs; and language-specific example programs.
- **DriverLINX** — the high-performance real-time data-acquisition device drivers for Windows application development includes:
 - DriverLINX API DLLs and drivers supporting the DAS-8 Series hardware.
 - Analog I/O Panel - A DriverLINX program that verifies the installation and configuration of DriverLINX to your DAS-8 Series board and demonstrates several virtual bench-top instruments.
 - Learn DriverLINX - an interactive learning and demonstration program for DriverLINX that includes a Digital Storage Oscilloscope.
 - Source Code - for the sample programs.
 - DriverLINX Application Programming Interface files - for the DAS-8 Series compiler.
 - DriverLINX On-line Help System - provides immediate help as you operate DriverLINX.
 - Supplemental Documentation - on DriverLINX installation and configuration; analog and digital I/O programming; counter/timer programming; technical reference; and information specific to the DAS-8 Series hardware.

- **DAS-8 Series utilities** — The following utilities are provided as part of both the DAS-8 Series standard software package:
 - DriverLINX Calibration Utility
 - DriverLINX Test Panel
- **DAS-8 Series register I/O map** — If you cannot satisfy your application's requirements with the available software packages and you are an experienced programmer, you may be able to program your DAS-8 Series board through direct register I/O instructions. Contact the factory for more information.

Note: Attempts to combine register-level programming of counter/timer functions with DriverLINX programming can produce unexpected results.

Accessories

The following accessories are available for use with DAS-8 Series boards:

- **STC-37 screw terminal connector** — For all DAS-8 Series boards, provides 37 screw terminals that allow you to access the functions of the board; connects directly to the DAS-8 Series board without a cable.
- **STP37 screw terminal panel** — For all DAS-8 Series boards, provides 37 screw terminals that allow you to access the functions of the board. Requires a C1800 or S1800 cable.
- **STA-08 screw terminal accessory** — For the DAS-8 or DAS-8/LT boards only, provides screw terminals that allow you to access the functions of the board; provides a breadboard area with power and additional screw terminals to access the user-designed circuitry. Requires a C1800 or S1800 cable.
- **STA-08PGA screw terminal accessory** — For the DAS-8/PGA and DAS-8/PGA/G2 boards only, provides screw terminals that allow you to access the functions of the board; provides a breadboard area with power and additional screw terminals to access the user-designed circuitry. Requires a C1800 or S1800 cable.
- **STA-08AO screw terminal accessory** — For the DAS-8/AO board only, provides screw terminals that allow you to access the functions of the board; provides a breadboard area with power and additional screw terminals to access the user-designed circuitry. Requires a C1800 or S1800 cable.
- **EXP-16 and EXP-16/A expansion boards** — Sixteen-channel multiplexer and signal-conditioning expansion boards that provide cold junction compensation (CJC) for thermocouples and switch-selectable gains ranging from 0.5 to 2000.
- **EXP-GP expansion board** — An 8-channel signal-conditioning expansion board; connects to RTDs, thermistors, strain gages, and other variable resistance sensors; provides CJC for thermocouples and switch-selectable gains of 1, 10, 100, and 1000 or 2.5, 25, 250, and 2500.

- **MB Series modules and backplanes** — MB Series modules are high-performance, signal-conditioning modules that measure thermocouple, RTD, strain gage, voltage, and current inputs and are installed in MB Series backplanes. MB Series backplanes provide screw terminals for connecting the high-level analog I/O signals.
- **ST-SCM8 screw terminal accessory** — Allows you to connect a DAS-8 Series board to up to four MB-02 backplanes; provides screw terminals that allow you to access the functions of the board; provides a breadboard area with power for the user-designed circuitry.
- **ISO-4 4-channel isolated multiplexer accessory board** — Expands one analog input into four galvanically isolated inputs.
- **C-1800 cable** — Unshielded, 18-inch cable with a 37-pin connector on each end; allows you to connect a DAS-8 Series board to an STA-08, STA-08PGA, EXP-16, EXP-16/A, or EXP-GP.
- **S-1800 cable** — Shielded, 18-inch cable with a 37-pin connector on each end; allows you to connect a DAS-8 Series board to an STA-08, STA-08PGA, EXP-16, EXP-16/A, or EXP-GP.
- **C8-MB1 cable** — Cable with a 37-pin connector on one end and a 26-pin connector on the other end; allows you to connect a DAS-8 Series board to an MB-01 or MB-02 backplane.
- **C-2600 cable** — An 18-inch cable with a 26-pin connector at each end; allows you to connect an STA-SCM8 screw terminal accessory to an MB-02 backplane.

Refer to the Keithley *Data Acquisition Catalog & Reference Guide* or contact your local sales office for information on obtaining these accessories.

2

Functional Description

This chapter describes the following features of DAS-8 Series boards:

- Analog input features
- Analog output features (DAS-8/AO)
- Digital I/O features
- Counter/timer I/O features
- Interrupts
- Power
- Measuring Voltage

A functional block diagram of a DAS-8 Series board is shown in Figure 2-1.

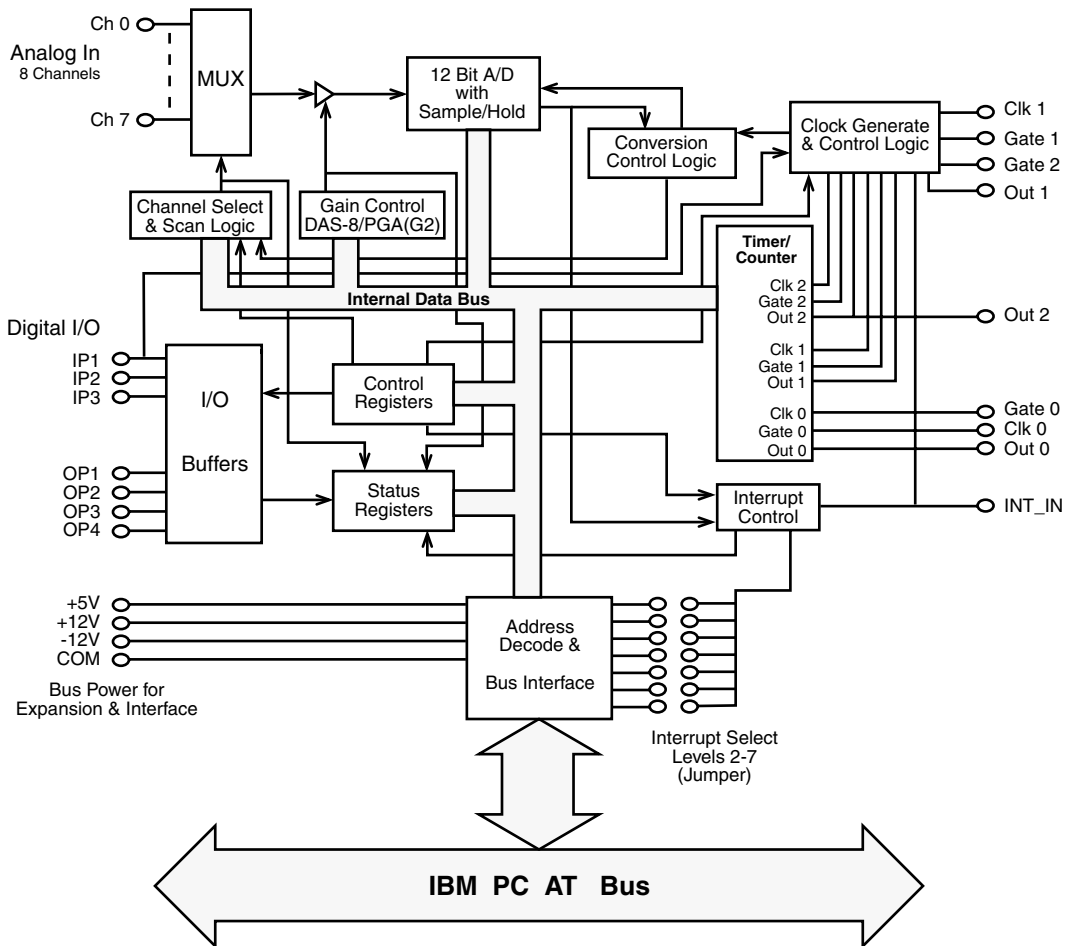

Figure 2-1. DAS-8 Series Functional Block Diagram

Analog Input Features

DAS-8 Series boards use a 12-bit, successive approximation analog-to-digital converter (ADC) with integral sample and hold. The ADC provides 12-bit resolution ± 1 least significant bit (LSB), providing an effective accuracy of 11 bits. The ADC converts one sample every $25\mu\text{s}$ ($25\mu\text{s}$ max.), providing an average conversion frequency of more than 4 kHz (machine and software dependent).

Channel Configuration

DAS-8 Series boards contain eight on-board analog input channels. The following subsections describe the input configurations supported for each channel, the gains and input ranges supported for each channel, and the methods of specifying a channel or channels for an analog input operation.

Input Configuration

The DAS-8 series boards contain eight analog input channels. DAS-8 and DAS-8/LT inputs are single-ended (sharing a common low level ground) with a fixed input range of -5.000V to +4.9976V. The DAS-8/PGA(G2) and DAS-8/AO, on the other hand, may be configured for either single-ended (signal measured against ground) or differential inputs (high side of signal measured against the low side) by means of a DIP switch located on the board. The differences between a single-ended and a differential input configuration are described as follows:

- **Single-ended** — A single-ended input configuration is appropriate if you are measuring relatively high-level signals (greater than 1V), if the source of the input signal is close to the board (less than two feet), or if all input signals are referred to a common ground. This configuration does not provide common-mode noise rejection.
- **Differential** — A differential input configuration is appropriate if you are measuring low-level signals, if high source resistances (greater than 100 Ω) exist, or if common-mode voltages exist between the voltage source and the host's chassis ground. In a differential configuration, a separate positive and negative terminal is provided for each channel. Any common-mode noise that is picked up equally on both inputs is rejected because the difference is zero.

You specify the input configuration by setting switches on the board. The switches connect or disconnect the inverting side of the input signal to low-level ground. Refer to page 3-12 for information on setting the switches.

Note: On the DAS-8 and DAS-8/LT, the channels are always configured as single-ended; all signals are referred to a single low-level ground.

If you are using EXP-16, EXP-16/A, or EXP-GP expansion boards or MB-02 backplanes, you must configure the on-board analog input channels associated with the expansion boards as single-ended.

Apply input voltages to the DAS-8 and DAS-8/LT between the channel Hi and any L.L. Gnd. Wire signals enter the DAS-8/PGA(G2) and DAS-8/AO between the Hi and Lo connection points and set switches on the SE/DIFF DIP switch accordingly. Regardless of which board you use, never wire signal returns to the digital common (DIG. COM.) as this is intended as a heavy current return for power supplies and digital logic signals, and it may differ from the low-level ground by several millivolts, resulting in errors that are difficult to trace.

Correct use of the grounds is important to obtain consistent noise-free measurements, because inadvertent ground loops are common when using single ended connections. Use low-level grounds for all analog signal returns to the DAS-8 and DAS-8/LT; they should carry signal currents less than a few milliamps. The seven identical low-level ground inputs are positioned in the connector so to lie between the analog channel inputs in the flat connecting cable. This reduces undesirable electrical noise, thus preventing crosstalk. The input current of each channel is about 100nA at 25°C, presenting a high input impedance to the signal. Also, the 508A solid-state channel multiplexer used on the DAS-8 Series board is designed to withstand continuous overloads of $\pm 32V$ on each channel and transients of several hundred volts. This multiplexer has two other desirable characteristics; a break-before-make action to prevent shorts between channels while switching and shutting OFF all channels when the power is off. This prevents signal-to-signal shorts when your computer is off.

Gains and Ranges

A DAS-8 board measures analog input signals in the range of $\pm 5V$.

Each DAS-8/PGA(G2) or DAS-8/AO board contains a programmable gain amplifier (PGA), which allows you to measure analog input signals in one of several software-selectable unipolar and bipolar ranges. For each channel on a DAS-8/PGA(G2) or DAS-8/AO board, you can specify one of five bipolar and four unipolar analog input ranges.

Table 2-1 lists the gains supported by DAS-8 Series boards and the analog input voltage range for each gain.

Table 2-1. Supported Gains

| Board | Gain | Range | |
|-------------------|------|-------------|---------------|
| | | Bipolar | Unipolar |
| DAS-8 DAS-8/LT | 1 | $\pm 5V$ | Not available |
| DAS-8/PGA | 0.5 | $\pm 10V$ | Not available |
| | 1 | $\pm 5V$ | 0 to 10V |
| | 10 | $\pm 500mV$ | 0 to 1V |
| | 100 | $\pm 50mV$ | 0 to 100mV |
| | 500 | $\pm 10mV$ | 0 to 20mV |
| DAS-8/PGA-G2 | 0.5 | $\pm 10V$ | Not available |
| | 1 | $\pm 5V$ | 0 to 10V |
| | 2 | $\pm 2.5V$ | 0 to 5V |
| | 4 | $\pm 1.25V$ | 0 to 2.5V |
| | 8 | $\pm 625mV$ | 0 to 1.25V |
| DAS-8/AO | 0.5 | $\pm 10V$ | 0 to 10V |
| | 1 | $\pm 5V$ | Not available |
| | 10 | $\pm 500mV$ | 0 to 1V |
| | 100 | $\pm 50mV$ | 0 to 100mV |
| | 500 | $\pm 10mV$ | 0 to 20mV |

Note: Analog input channels on DAS-8 Series boards are provided with protection against signals outside the specified analog input range. All DAS-8 Series boards can tolerate voltages up to $\pm 35\text{V}$ and transients of several hundred volts without damaging the board.

When measuring signals at differential inputs, DAS-8/PGA(G2) and DAS-8/AO boards can tolerate common-mode voltages up to $\pm 35\text{V}$ and transients of several hundred volts without damaging the board; however, for normal operation of the board, make sure that the common-mode voltage is no more than $12\text{V} - ((G / 2) \times V_D)$, where G is the gain and V_D is the differential input voltage.

The DAS-8/PGA(G2) and DAS-8/AO support voltage input ranges from ± 10 volts to ± 0.01 volts (bipolar) and $+10\text{VDC}$ to 0.02VDC (unipolar). Higher voltages may be measured by the use of simple resistive dividers. Each DAS-8/PGA(G2) or DAS-8/AO input channel can be configured for either single-ended or differential inputs by means of Switch S2. The DAS-8/PGA(G2) has a built-in differential amplifier to minimize errors from Common Mode voltages. A DAS-8/PGA(G2) input channel should be configured for single-ended (SE position of SW2 for each channel) when attempting to measure floating signals. Grounded signals should be read in the differential configuration to reduce common-mode error. When using the DAS-8/PGA(G2) and DAS-8/AO with the EXP-16, all DAS-8/PGA(G2) and DAS-8/AO channels should be set for single-ended inputs.

The DAS-8 and DAS-8/LT provide a $+10\text{V}$ A/D voltage reference (V_{ref}). It may be used for offsetting signals, but should not be heavily loaded. The maximum available output current is 2mA . Since this reference is shared by the A/D, any overload or shorting of the reference will affect the scaling of the A/D.

Channel Selection

You can use DAS-8 Series boards to acquire data from a single analog input channel or from a range of contiguous, on-board analog input channels using automatic channel scanning. These two methods of channel selection are described as follows:

- **Single channel** — You use software to specify a single channel and initiate a conversion.
- **Automatic channel scanning** — You use software to specify the first and last channels in a range of contiguous, on-board channels (0 to 7). The channels are sampled in order from first to last; the hardware automatically increments the analog input multiplexer address shortly after the start of each conversion. When the last address is reached, the multiplexer returns to the start address and the channels are sampled again. For example, assume that the start channel is 4, the stop channel is 7, and you want to acquire five samples. Your program reads data first from channel 4, then from channels 5, 6, and 7, and finally from channel 4 again.

Note: An error results if the start channel number is higher than the stop channel number.

When using automatic channel scanning, all contiguous, on-board channels must have the same gain (analog input range).

Note: DriverLINX allows you to acquire data from a range of multiple channels that includes channels on expansion boards or MB Series backplanes. The Expansion Board Configuration for Keithley DAS-8 Series dialog in DriverLINX of the Special selection of the Device Subsystem Page allows you to record the settings of your analog input multiplexers and enable the expansion channels. Refer to *Appendix F: Configuration and Implementation Notes, Keithley DAS-8 Series* manual that accompanies DriverLINX.

Automatic channel scanning is a hardware feature. In multi-channel range mode, the DAS-8 Series acquires all data from a consecutive range of analog channels.

- The Start Channel's gain only applies to the first channel.
- DriverLINX uses the Stop Channel's gain for all the other analog channels in the range.
- If the Start Channel is greater than the Stop Channel, the channel sequence is [Start Channel, ..., Last Channel, 0, ..., Stop Channel], where Last Channel is the highest numbered channel for the DAS-8 model the application is using.

In multi-channel list mode, the DAS-8 Series acquires all data from a random list of analog channels.

- The channel-gain list may contain up to 256 channels in any order with any allowed gain.
- The list may repeat the same channel with the same or different gains.

Automatic channel scanning is a hardware feature. The functions used to create a group of channels (sequential or non-sequential) or a channel-gain list emulate automatic channel scanning through software. Therefore, the maximum attainable conversion frequency is reduced when using a group of consecutive channels or a channel-gain list.

Channel Expansion

If you require additional analog input channels or signal conditioning for transducer inputs, you can use any combination of up to eight 16-channel EXP-16 expansion boards, eight 16-channel EXP-16/A expansion boards, and/or eight 8-channel EXP-GP expansion boards to increase the number of available channels to 128. You can also use up to four MB-02 backplanes to increase the number of available channels to 68. When using the DAS-8 series boards with the EXP-16(s), the DAS-8 series board should be configured as single-ended inputs by setting Switch S2.

For the EXP-16, EXP-16/A, and EXP-GP, you attach the expansion boards in a daisy-chain configuration using the S-1800 or C-1800 cable. The first expansion board in the daisy chain is associated with on-board channel 0, the next expansion board is associated with on-board channel 1, and so on. You specify the associated on-board channel by setting a jumper on each expansion board. You can access any unused on-board channels by attaching an STA-08 or STA-08PGA screw terminal accessory to the last expansion board in the daisy-chain configuration.

Each EXP-16 (group of 16 channels) can operate at a different gain. In this way a system can be configured with a variety of different channel functions and gains, single-ended and differential.

Note: The PG408 DC/DC Converter option on the EXP-16 is required for use with the DAS/AO board.

Figure 2-2 illustrates a daisy-chain configuration of two EXP-16 expansion boards, one EXP-GP expansion board, and an STA-08 screw terminal accessory connected to a DAS-8 board.

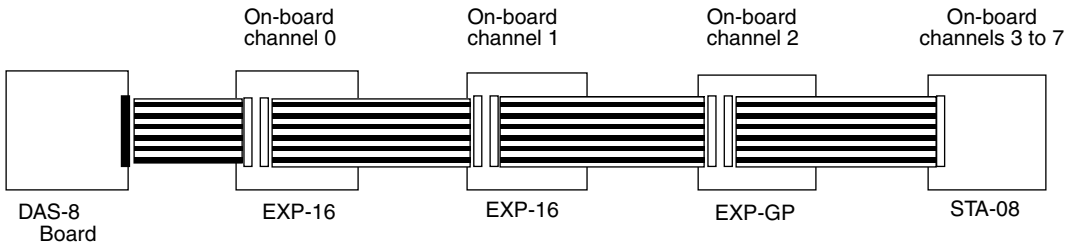

Figure 2-2. Channel Expansion

Refer to the appropriate expansion board documentation for more information about the EXP-16, EXP-16/A, and EXP-GP expansion boards.

For information on attaching multiple MB-02 backplanes, refer to the *MB Series User's Guide*.

Clock

The input to the counter/timers used for A/D timing varies. The DAS-8/LT uses the PC bus clock while the DAS-8/PGA(G2) and DAS-8/AO have an on-board 1MHz crystal oscillator. The frequency of the PC bus may be determined automatically as described below.

Custom Clock Frequencies

For timing, the DAS-8 Series uses the clock signal on the PC I/O bus or an on-board crystal oscillator. While the original IBM PC XT and compatibles always had a 2.384MHz bus clock, ISA Nd EISA bus machines have no accepted standard for PC bus clock. On many machines, the clock frequency is one-half the CPU clock frequency, while on others it is adjustable using motherboard jumpers or advanced BIOS setup options. Few manufacturers provide this information in their documentation. This frequency, however, can be measured by DriverLINX using the 82C54 timer/counters on the DAS-8.

To measure the PC bus clock frequency, DriverLINX requires that Counters 1 and 2 be chained together using an external jumper. To chain the counters, connect Counter 2 Out [6] to Counter 1 IN [4] on the DAS-8 external connector.

Then, using DriverLINX, select the Counter/Timer Section in the Configuration Dialog Box. Choosing the item "Custom clock" in the drop-down list of the Resolution combo-box displays the Custom Clock Frequency Dialog Box. Selecting Measure will start a 30-second measuring interval for determination of the PC bus clock frequency. The frequency box will update every second with the currently measured frequency. The measuring interval may be stopped at any time using the Stop pushbutton. The displayed frequency is added to the Resolution list box by selecting OK, or the measurement can be abandoned by selecting Cancel. The displayed frequency may be edited manually by selecting the numbers in the edit box and typing a new value for the selected digits.

Conversion Clock Sources (DAS-8/PGA(G2), DAS-8/AO, and DAS-8/LT)

The conversion clock source determines when each analog-to-digital (A/D) conversion is initiated. DAS-8/PGA(G2), DAS-8/AO, and DAS-8/LT boards provide the following software-selectable conversion clock sources:

- **Software** — When using a software conversion clock, the host computer issues a command to initiate a conversion. The host polls the board to determine if the conversion is complete. When the conversion is complete, the host reads the data from the ADC and returns the value. If the host reads data before the conversion is complete, the data will be invalid.

Software-initiated conversions are suitable for measuring DC voltages; however, in applications where you must accurately control the sampling rate (as when measuring time-varying signals), it is recommended that you use either an internal or an external hardware conversion clock source.

At power-up or system reset, the board assumes that conversions will be initiated through software.

- **Hardware (internal clock source)** — The input to the counter/timers used for A/D timing varies. The DAS-8 uses the PC bus clock while the DAS-8/PGA (G2), DAS-8/AO, and DAS-8/LT have an on-board 1 MHz crystal oscillator. The frequency of the PC bus may be determined automatically as described above.
- The internal clock source uses the on-board 82C54 counter/timer circuitry and a crystal-controlled 1MHz time base. The 82C54 counter/timer circuitry is normally in an idle state. When you start an analog input operation, a conversion is initiated immediately. The 82C54 is loaded with its initial count value and begins counting down. When the 82C54 counts down to 0, another conversion is initiated and the process repeats.

Because the 82C54 counter/timer uses a 1MHz time base, each count represents 1 μ s. For example, if you load a count of 25, the time interval between conversions is 25 μ s; if you load a count of 65536, the time interval between conversions is 65.536ms.

The 82C54 contains three counter/timers: C/T0, C/T1, and C/T2. If you are using a hardware internal clock source, the time base logic uses C/T1 and C/T2 in either normal or cascaded mode, as follows:

- *Normal Mode* - A software-selectable count is loaded into C/T2 of the 82C54 counter/timer circuitry. Each time C/T2 reaches terminal count, a conversion is initiated. The time interval between conversions ranges from 25 μ s to 65.536ms.
- *Cascaded Mode* - A software-selectable count is divided between C/T2 and C/T1 of the 82C54 counter/timer circuitry. When C/T2 counts down to 0, C/T1 decrements by 1. C/T2 is reloaded with its count value and begins counting down again. Each time C/T2 counts down to 0, C/T1 decrements by 1. Each time both C/T2 and C/T1 reach terminal count, a conversion is initiated. The time interval between conversions ranges from 25 μ s to 1.2 hours.

Refer to page 2-20 for more information about the 82C54 counter/timer circuitry.

- **Hardware (external clock source)** — An external clock source is useful if you want to sample at rates not available with the 82C54 counter/timer circuitry, if you want to sample at uneven intervals, or if you want to sample on the basis of an external event. An external clock also allows you to synchronize conversions on multiple boards to a common timing source.

The external clock source is an externally applied TTL-compatible signal, which you attach to the INT_IN / XCLK pin (pin 24) of the main I/O connector. When you start an analog input operation, conversions are armed. At the next falling edge of the external clock source (and at every subsequent falling edge of the external clock source), a conversion is initiated.

Note: If you are using a hardware external clock source, you cannot use the INT_IN / XCLK pin (pin 24) to generate interrupts.

Figure 2-3 illustrates how conversions are initiated when using an internal and an external clock source. (Note that Figure 2-3 assumes that you are not using a hardware trigger; refer to Figure 2-4 for an illustration of conversions when using a hardware trigger.)

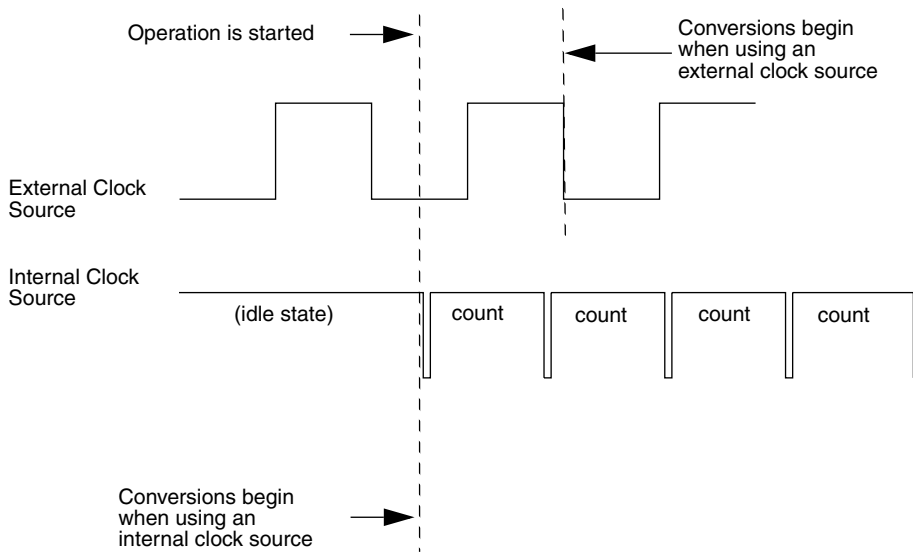

Figure 2-3. Initiating Conversions

Note: The ADC acquires data at a maximum of 4kHz (one sample every 25 μ s). If you are using a hardware external clock, make sure that the clock does not initiate conversions at a faster rate than the ADC can handle.

If you are acquiring samples from multiple channels, the maximum sampling rate for each channel is equal to 4kHz divided by the number of channels.

The rate at which the computer can reliably read data from the board depends on a number of factors, including your computer, the operating system/environment, whether you are using expansion boards, the gains of the channels, and software issues.

You can synchronize conversions on multiple DAS-8 Series boards to a common, externally applied conversion clock. In addition, you can use a DAS-8/PGA, DAS-8/PGA(G2), DAS-8/AO, or DAS-8/LT board as a timing master; the output of the OUT1 pin (pin 5) on the main I/O connector of the master board acts as an external hardware conversion clock to any additional boards. You can use external circuitry, such as C/T0 on the 82C54, to divide the rate of the master clock. This allows you to synchronize conversions on the additional boards to a rate different from that of the master board. Refer to page 4-14 for more information on synchronizing conversions on multiple boards.

Triggers

A trigger is an event that must occur before a DAS-8 Series board starts an analog input operation. You can use one of the following trigger sources to trigger an analog input operation:

- **Software** — When you start the analog input operation, conversions begin immediately.
- **Hardware** — You connect a digital trigger signal to the digital input IP1/TRIG pin (pin 25) of the main I/O connector. The trigger event occurs when the board detects a rising edge on IP1/TRIG.

The actual point at which conversions begin depends on whether you are using an internal or external clock source. These considerations are described as follows:

- *Internal clock source* - The 82C54 counter/timer circuitry remains idle until the trigger event occurs. When the trigger event occurs, the board initiates the first conversion immediately.
- *External clock source* - Conversions are armed when the trigger event occurs. At the next falling edge of the external clock source, the board initiates the first conversion.

Figure 2-4 illustrates how conversions are started when using a hardware trigger.

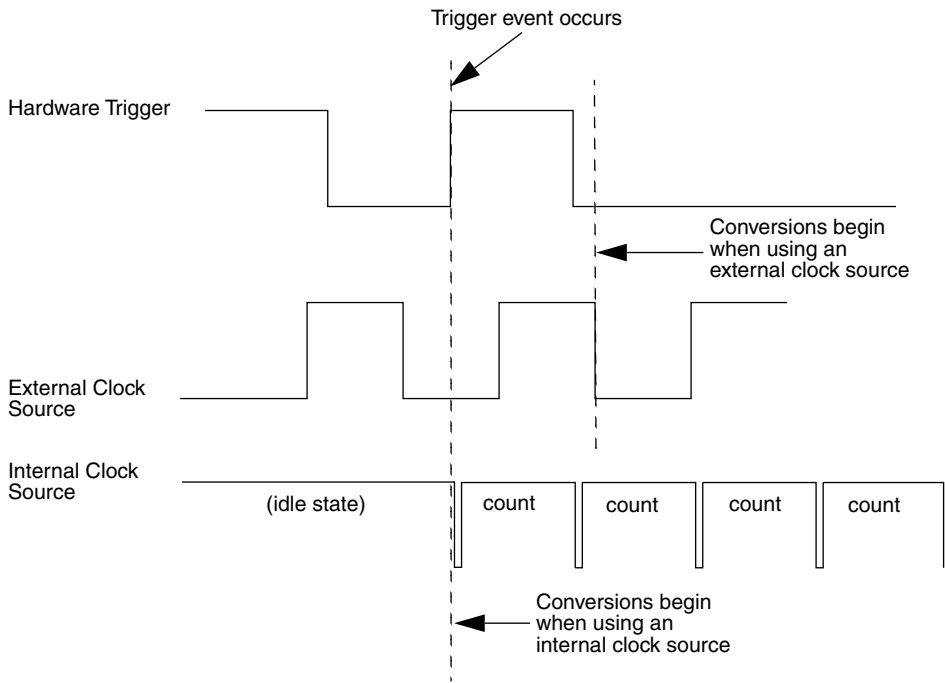

Figure 2-4. Initiating Conversions with a Hardware Trigger

Hardware Gates

A hardware gate is an externally applied digital signal that determines whether conversions occur. You connect the gate signal to the IP1/TRIG pin (pin 25) on the main I/O connector. DAS-8 Series boards support a positive gate only. Therefore, if the hardware gate is enabled and the signal to IP1/TRIG is high, conversions occur; if the signal to IP1/TRIG is low, conversions are inhibited.

Note: You cannot use the hardware gate with a hardware trigger. However, the gate signal itself can act as a trigger. If the gate signal is low when the software starts the analog input operation, the board waits until the gate signal goes high before conversions begin.

When using the hardware gate, the way conversions are synchronized depends on whether you are using a hardware external clock or a hardware internal clock, as follows:

- **External clock** — The signal from the external clock continues uninterrupted while the gate signal is low; therefore, conversions are synchronized to the external clock.
- **Internal clock** — The 82C54 does not count while the gate signal is low. Whenever the gate signal goes high, the 82C54 is loaded with its initial count value and starts counting; therefore, conversions are synchronized to the gate signal.

Figure 2-5 illustrates how to use the hardware gate with both an external clock and an internal clock.

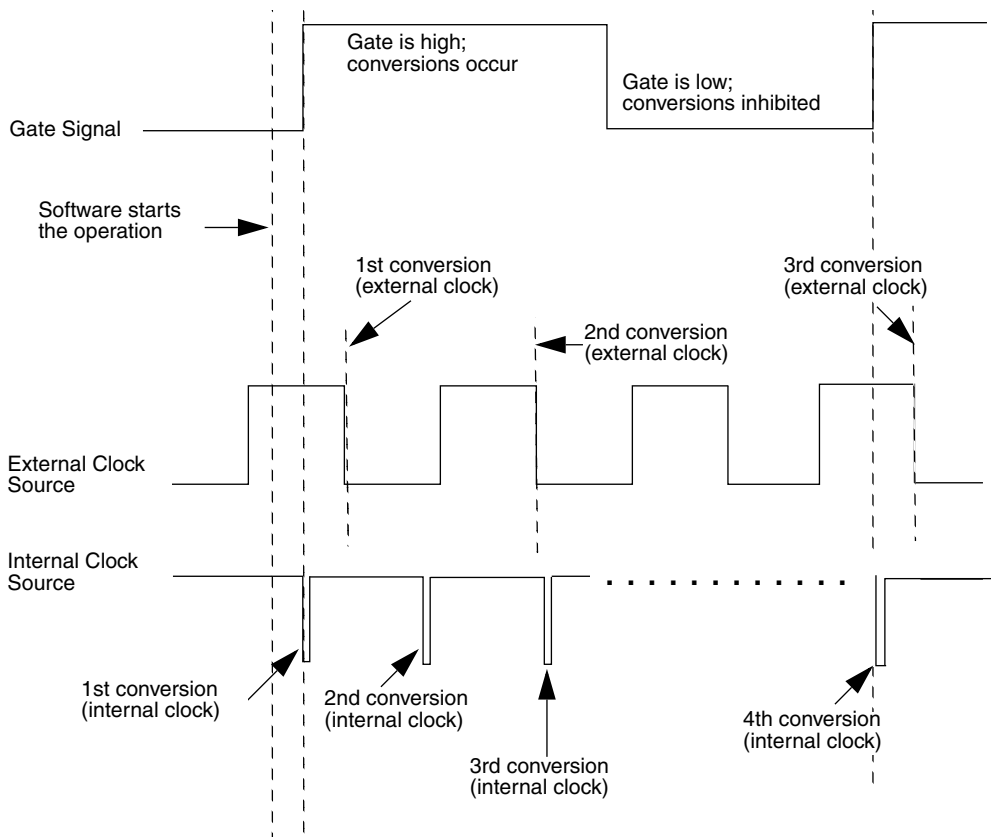

Figure 2-5. Hardware Gate

Note: Although DAS-8 Series boards do not provide a hardware-based analog trigger, you can program an analog trigger through software, using one of the analog input channels as the trigger channel. DriverLINX provides functions for both an analog trigger and a digital trigger. Refer to the *DriverLINX Appendix F: Configuration and Implementation Notes: Keithley DAS-8 manual* for more information.

Data Transfer

Because DAS-8 Series boards do not support DMA (Direct Memory Access), data is always transferred from a DAS-8 Series board to the host computer's memory through an output port. Data can be transferred as either a foreground process or a background process. If data is transferred in the background, the end-of-conversion interrupt must be enabled so the board can notify the host computer when new data is available. Refer to page 2-26 for more information about interrupts. If data is transferred in the foreground, interrupts are not required.

DAS-8/AO Analog Output Features

The DAS-8/AO is essentially a DAS-8/PGA with two DAC (Digital-to-Analog Converter) channels.

Output data to DAC Channel 0 or 1 is written when the DAS-8/AO is configured for normal updates. If the DACs are set for simultaneous update, both channels are updated at the same time.

If DACs are configured for Update on Interrupt when configured for normal update, DAC channel 0 or 1 is updated on interrupt. If the DACs are set for simultaneous update, both DAC channels are updated on interrupt.

Digital I/O Features

DAS-8 Series boards contain three digital input lines and four digital output lines. The digital input lines are associated with the IP1, IP2, and IP3 pins on the main I/O connector; the digital output lines are associated with the OP1, OP2, OP3, and OP4 pins on the main I/O connector. Logic 1 at a pin indicates that the input/output is high (greater than 2.0V); logic 0 at a pin indicates that the input/output is low (less than 0.8V).

The digital input lines are compatible with TTL-level signals. If no signal is connected to a digital input line, the input appears high (logic 1).

You can use the digital input and output lines for any general-purpose task, with the following exceptions:

- If you are using an expansion board for an analog input operation, the four digital output lines control the multiplexers on the expansion boards to determine the expansion board channel that is acquiring data. In this case, you cannot use the digital output lines for general-purpose digital output operations.
- If you are using an external digital trigger or hardware gate, you must use the IP1 pin to attach the trigger/gate signal. In this case, you cannot use IP1 for general-purpose digital input operations.

82C54 Counter/Timer Circuitry

Each DAS-8 Series board contains 82C54 counter/timer circuitry; the 82C54 contains three counter/timers: C/T0, C/T1, and C/T2.

C/T0 is always available for general-purpose tasks. If you are using a hardware internal clock source for an analog input operation, both C/T1 and C/T2 of the 82C54 counter/timer circuitry are dedicated to internal functions and cannot be used for general-purpose tasks. If you are using a hardware external clock source, C/T0, C/T1, and C/T2 are always available for general-purpose tasks.

C/T0 and C/T1 have a clock input pin on the main I/O connector; all counter/timers have a gate input pin and an output pin on the main I/O connector. You can attach a clock source (0 to 10MHz) to the clock input pins (CLK0 and CLK1). Pull-up resistors of 3.3k Ω are provided on the three gate input pins (GATE0, GATE1, and GATE2). Therefore, the gates appear enabled if no signal is attached to the gate inputs. You can use the output pins (OUT0, OUT1, and OUT2) for pulse or frequency outputs.

You can program the 82C54 counter/timer circuitry to operate in one of the following counter/timer modes:

- **Pulse on terminal count (Mode 0)** — This mode is useful for event counting or for programming a time delay. The software forces the output low. On the next clock pulse after the software writes the initial count value, the counter is loaded. When the counter reaches zero, the output goes high and remains high until the software writes a new count value. Note that the output does not go high until $n + 1$ clock pulses after the initial count is written, where n indicates the loaded count.

A high gate input enables counting; a low gate input disables counting. The gate input has no effect on the output. Note that an initial count value written while the gate input is low is still loaded on the next clock pulse.

Figure 2-6 illustrates pulse on terminal count mode.

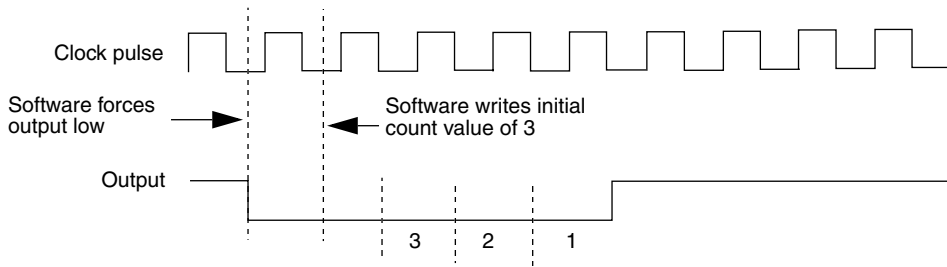

Figure 2-6. Pulse on Terminal Count Mode

- Programmable one-shot (Mode 1)** — This mode is useful for providing a hardware-triggered delay or one-shot pulse. The output is initially high. A trigger loads the initial count value into the counter. At the next clock pulse after the trigger, the output goes low and remains low until the counter reaches zero. (The one-shot pulse is n clock cycles in duration, where n indicates the loaded count.) After the counter reaches zero, the output goes high and remains high until the clock pulse after the next trigger; this makes the one-shot pulse retriggerable.

You do not have to reload the count into the counter. The gate input has no effect on the output. Writing a new count to the counter during a one-shot pulse does not affect the current one-shot pulse.

Figure 2-7 illustrates programmable one-shot mode.

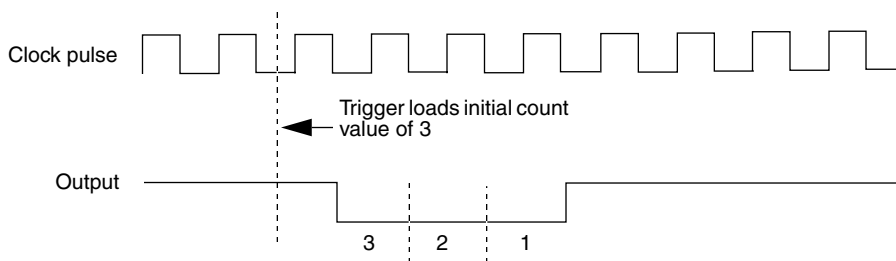

Figure 2-7. Programmable One-Shot Mode

- **Rate generator (Mode 2)** — This mode is useful for generating a real-time clock interrupt. The output is initially high. A trigger loads the initial count value into the counter. At the next clock pulse after the trigger, the counter starts counting down. When the counter reaches one, the output goes low for one clock pulse and then goes high again. The counter is then reloaded with the initial count value and the process repeats.

A high gate input enables counting; a low gate input disables counting. If the gate goes low during an output pulse, the output is set high immediately; this allows you to use the gate input to synchronize the counter.

Writing a new count to the counter while counting does not affect the current counting sequence. In this mode, a count of 1 is illegal.

Figure 2-8 illustrates rate generator mode.

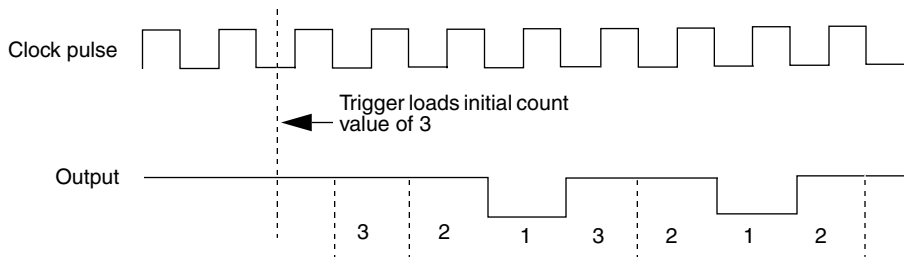

Figure 2-8. Rate Generator Mode

- Square-wave generator (Mode 3)** — This mode is useful for square-wave generation. The output is initially high. A trigger loads the initial count value into the counter. At the next clock pulse after the trigger, the counter starts counting down. When half the initial count has elapsed, the output goes low for the remainder of the count. When the total count elapses, the counter is reloaded with the initial count value, the output goes high again, and the process repeats. If the initial count is odd, the output is high for $(n + 1) / 2$ counts and low for $(n - 1) / 2$ counts, where n indicates the loaded count.

A high gate input enables counting; a low gate input disables counting. If the gate goes low while the output is low, the output is set high immediately. This allows you to use the gate input to synchronize the counter.

Figure 2-9 illustrates square-wave generator mode.

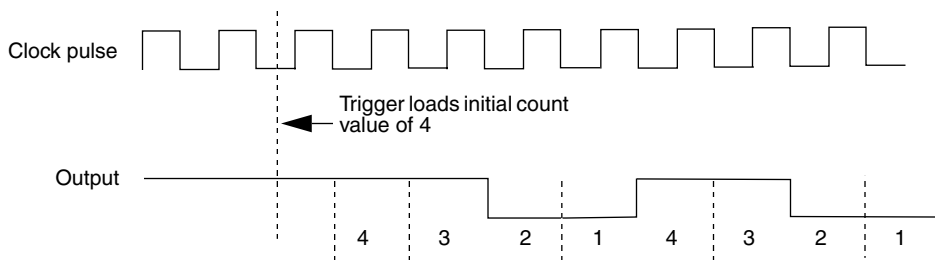

Figure 2-9. Square-Wave Generator Mode

- **Software-triggered strobe (Mode 4)** — The output is initially high. Writing the initial count through software loads the initial count value into the counter at the next clock pulse, but the counter does not start counting. At the next clock pulse, the counter starts counting down. When the counter reaches zero, the output goes low for one clock pulse and then goes high again. Note that the output does not go low until $n + 1$ clock pulses after the initial count is written, where n indicates the loaded count.

A high gate input enables counting; a low gate input disables counting. The gate input has no effect on the output.

Figure 2-10 illustrates software-triggered strobe mode.

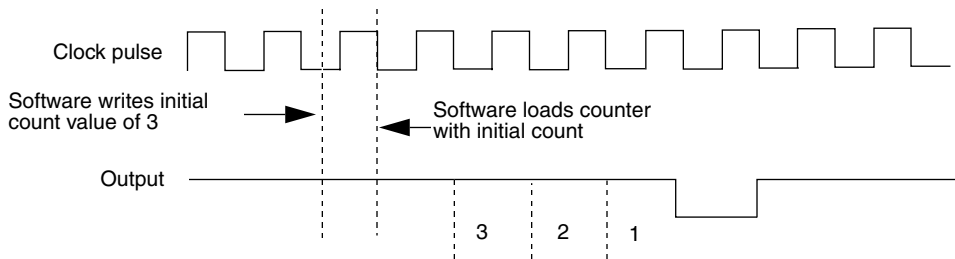

Figure 2-10. Software-Triggered Strobe Mode

- **Hardware-triggered strobe (Mode 5)** — The output is initially high. A rising edge of the gate input acts as a trigger. The counter is loaded with the initial count value on the next clock pulse after the trigger, but the counter does not start counting. At the next clock pulse, the counter starts counting down. When the counter reaches zero, the output goes low for one clock pulse and then goes high again. Note that the output does not go low until $n + 1$ clock pulses after the trigger event occurs, where n indicates the loaded count.

After the trigger event occurs, the gate input has no effect on the output. Writing a new value during counting does not affect the counting sequence.

Figure 2-11 illustrates hardware-triggered strobe mode.

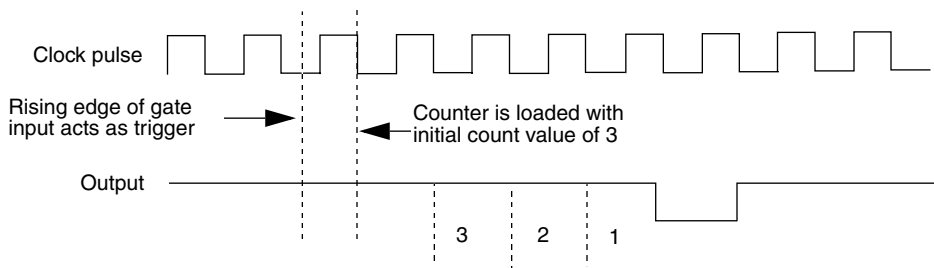

Figure 2-11. Hardware-Triggered Strobe Mode

Refer to 82C54 documentation for information on programming the 82C54 counter/timer circuitry for general-purpose tasks. Table 2-2 lists several companies that provide documentation for the 82C54.

Table 2-2. Sources for 82C54 Documentation

| Company | Address and Telephone Number |
|---------------------------|---|
| Intel Corporation | Literature Sales P.O. Box 7641 Mt. Prospect, IL 60056-7641 (800) 468-3548 |
| Harris Semiconductor | Literature Department P.O. Box 883, MS CB1-28 Melbourne, FL 32901 (407) 724-3739 |
| Newbridge Microsystems | 603 March Road Kanata, Ontario Canada K2K 1X3 (613) 592-0714 (800) 267-7231 |

Interrupts

DAS-8 Series boards can generate interrupts from one of the following interrupt sources:

- **External interrupt** — An interrupt is generated when a rising edge is applied to the INT_IN/XCLK pin (pin 24) on the main I/O connector.

Note: If you are using an external interrupt, you cannot use the INT_IN/XCLK pin (pin 24) to connect a hardware external clock source.

- **End-of-Conversion (EOC) interrupt** — An interrupt is generated when an A/D conversion is complete.

The interrupt source is software-selectable. At power-up or system reset, the board assumes that the interrupt source is an external interrupt.

You can select only one interrupt at a time. If you are using an interrupt, you must select the interrupt level (2, 3, 4, 5, 6, or 7) using a jumper on the board. If you are not using an interrupt, you can disable interrupts using a jumper on the board. Refer to page 3-13 for more information.

Note: If you are acquiring data in the background, interrupts must be enabled and the interrupt source must be an EOC interrupt.

If an interrupt condition is satisfied, an on-board flip-flop is set. If interrupts are enabled (through both hardware and software), the board generates an interrupt to the host, driving the selected host interrupt line to an active state.

Power

The analog circuitry on the DAS-8 board is powered by the $\pm 12\text{V}$ of the host computer. The DAS-8/PGA(G2) and DAS-8/AO boards contain a DC/DC converter to provide power to the analog circuitry.

Note: Many laptop computers and other types of battery-operated computers do not have a -12V power supply. If your computer does not have a -12V power supply, you need to use a DAS-8/LT board.

The host computer can provide power for EXP-16, EXP-16/A, and EXP-GP expansion boards and MB Series backplanes; however, certain power limitations exist. Table 2-3 lists the maximum number of expansion boards and backplanes that the host can power.

Table 2-3. Expansion Board/Backplane Power Limitations

| Expansion Board/Backplane | Maximum Number Powered by Host |
|----------------------------------|---------------------------------------|
| EXP-16 | 4 |
| EXP-16/A | 4 |
| EXP-GP | 3 |
| MB-01 | Always use external power. |
| MB-02 | Always use external power. |
| MB-03 | 4 |
| MB-04 | 2 |
| STA-1360 | 4 |

If you want to use more expansion boards or backplanes than indicated in Table 2-3, you must connect an external power supply to the additional expansion boards or backplanes. Refer to the appropriate expansion board documentation for information on providing external power to EXP-16, EXP-16/A, and EXP-GP expansion boards. Refer to the *MB Series User's Guide* for information on providing external power to MB Series backplanes.

Setup and Installation

This chapter describes how to install the software in your computer, unpack and inspect the board, configure the board, and install the board in your computer. Read this chapter and all related DriverLINX documentation before you attempt to install and use your DAS-8 Series board.

Installation Procedure

Installing and configuring DriverLINX for the DAS-8 Series boards requires four steps:

1. **Unpack the Board and Configure the Switches and Jumpers** — Follow the instructions in this chapter to configure the DAS-8 Series board. See *Installing the Board* on page 3-25.
2. **Install DriverLINX** — Follow the instructions given by the installation program. The *Read Me First* instructions explain the components and drivers you can install. See *Installing and Configuring DriverLINX for DAS-8 Series Boards* on page 3-21.
3. **Configure DriverLINX** — See *Configuration with DriverLINX* on page 3-25 for configuration options specific to the DAS-8 Series model.
4. **Install your DAS-8 hardware** — Read and follow instructions in section *Installing the Board* on page 3-25 of this manual.

Unpacking the Board

To prevent any damage to your DAS-8 Series board, perform the following steps when unpacking the board:

1. Remove the wrapped DAS-8 Series board from its outer shipping carton.
2. Ensure that your computer is turned OFF but grounded, then hold the wrapped board in one hand while placing your other hand firmly on a metal portion of the computer chassis to discharge any static electricity.
3. Carefully remove the board from its anti-static wrapping material. (Store the wrapping material for future use.)
4. Inspect the board for signs of damage. If any damage is apparent, arrange to return the board to the factory; refer to Section 6 for more information.
5. Check the remaining contents of your package against the packing list to ensure that your order is complete. Report any missing items to the factory immediately.
6. Once you have determined that the board is acceptable, you can configure the board. Refer to the next section for configuration options.

DAS-8 Series Boards

If you are familiar with switches and jumpers and with the items that are configurable on DAS-8 Series boards, you can use Figure 3-1 as a quick reference for configuring a DAS-8 board; Figure 3-2 as a quick reference for configuring a DAS-8/LT; Figure 3-3 for configuring a DAS-8/PGA(G2) board; Figure 3-4 for configuring a DAS-8/AO board. If you need additional information, refer to *Configuring the Board* on page 3-7.

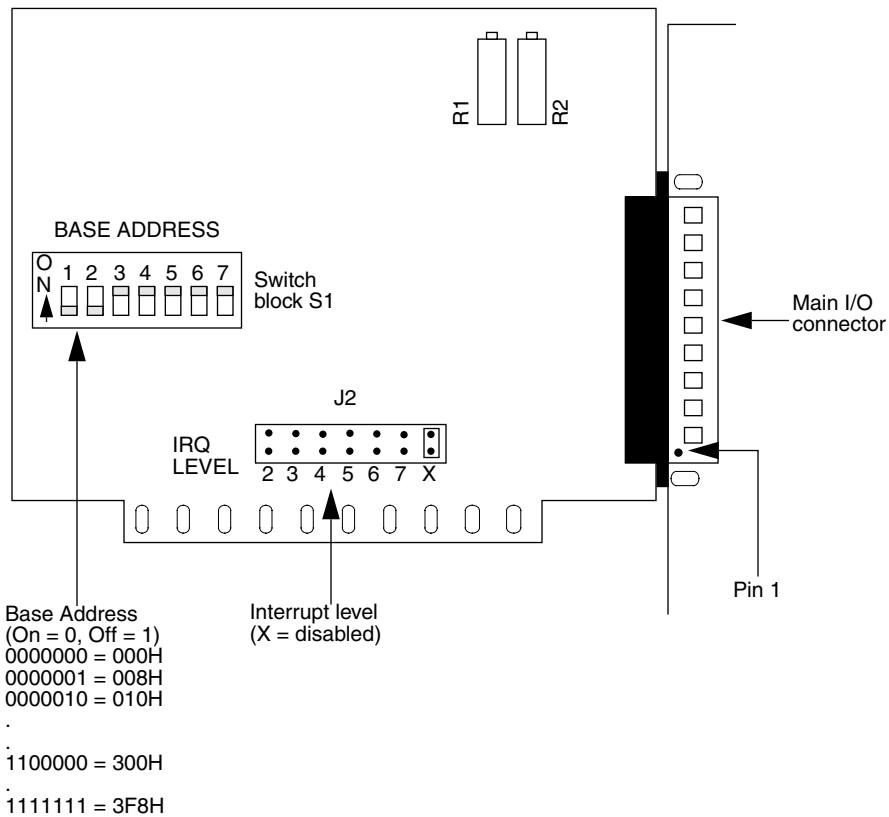

Figure 3-1. DAS-8 Board

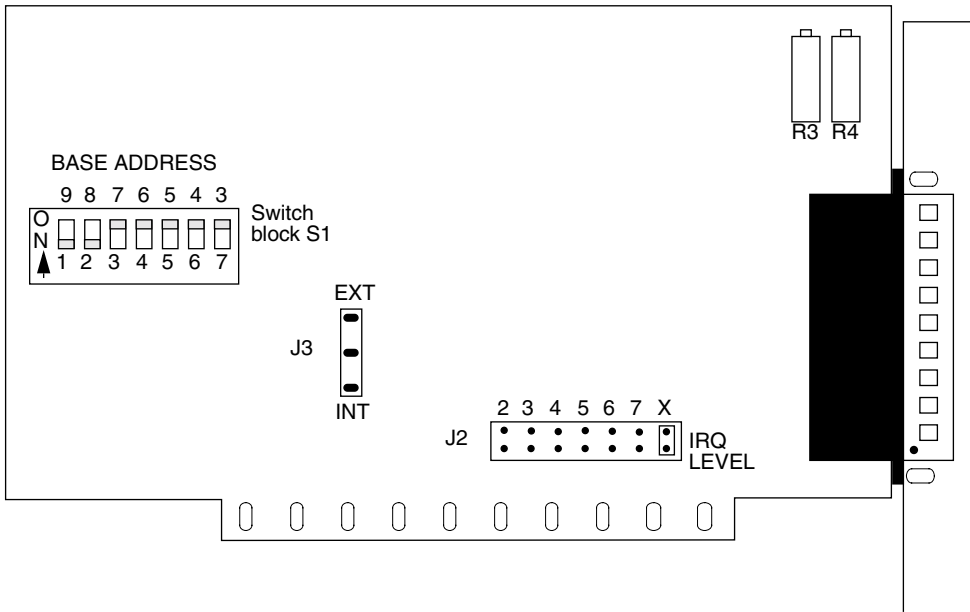

Figure 3-2. DAS-8/LT Board

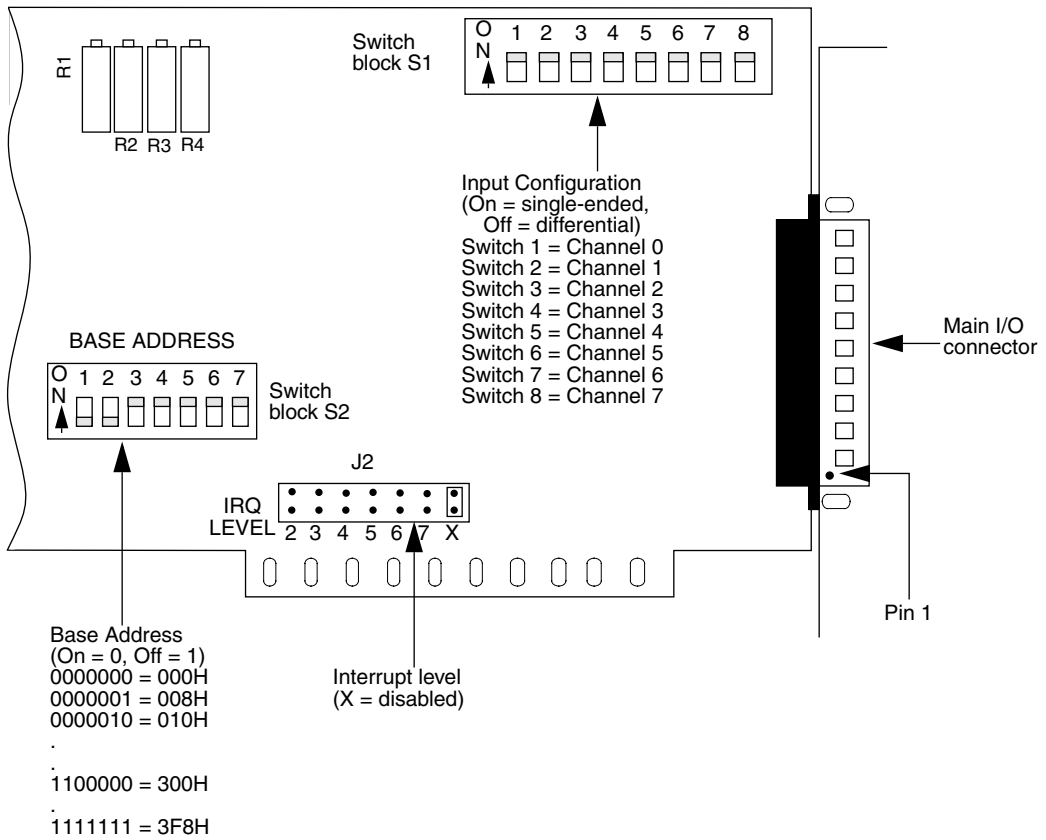

Figure 3-3. DAS-8/PGA(G2) Board

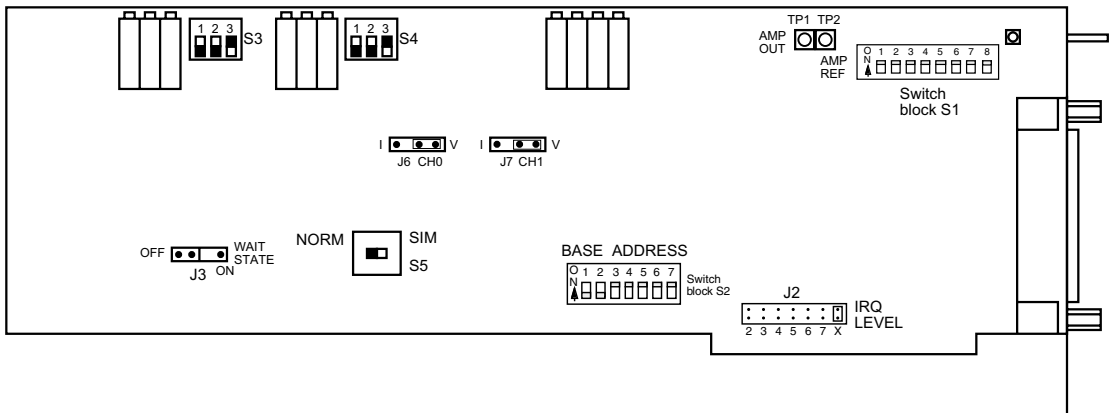

Figure 3-4. DAS-8/AO Board

Configuring the Board

Be sure to make note of the configuration of all switches and jumpers on the board. You will use this information to enter the correct configuration parameters using DriverLINX. Also locate any information or notes about the interrupt and DMA channels used by the other hardware devices in your computer system.

You can configure the following items on DAS-8 Series boards:

- Base address (required by DriverLINX and other software packages to perform DAS-8 Series board operations).
- Use of C/T2 on the 82C54 (cascaded or normal).
- Input range type (unipolar or bipolar) for a DAS-8/PGA(G2) or DAS-8/AO board.
- Input configuration (single-ended or differential) for each channel on a DAS-8/PGA(G2) or DAS-8/AO board.
- Interrupt level.
- DAS-8/AO configuration settings:
 - Analog output (voltage/current, range)
 - Output channels data output (normal/simultaneous)
 - Wait state (enabled or disabled)
- DAS-8/LT configuration for clock selection.
- Expansion boards used (information includes the number of expansion boards, the gains used by channels on the expansion boards, and the channel used as the CJC sensor).

Note: For EXP-16, EXP-16/A, and EXP-GP expansion boards, you must also set switches on the expansion boards to specify the gains used by channels on the expansion boards. Refer to the appropriate expansion board documentation for information about setting the switches.

Setting the Base Address

DAS-8 Series boards are shipped with a base address of 300H. If any of the address locations between 300H and 307H are being used by another resource in your system (including another DAS-8 Series board), you must reconfigure the base address using the base address switch block (labeled S1 on the DAS-8/LT board; labeled S2 on DAS-/PGA(G2) and DAS-8/AO boards).

Note: To change the address, refer to the *DriverLINX Appendix F: Configuration and Implementation Notes — Keithley DAS-8 manual*.

The base address switch block contains seven switches, labeled 1 through 7. Switch 1 corresponds to the most significant bit (MSB) of the base address; switch 7 corresponds to the LSB of the base address. The location of the base address switch block on the DAS-8 board is shown in Figure 3-1; the location of the base address switch block on the DAS-8/LT is shown in Figure 3-2; DAS-8/PGA(G2) boards is shown in Figure 3-3; and DAS-8/AO is shown in Figure 3-4.

You place a switch in the ON position (logic 0) by sliding the switch toward the top (numbered side) of the switch block. You place a switch in the OFF position (logic 1) by sliding the switch toward the bottom (unnumbered side) of the switch block.

Figure 3-5 illustrates the setting for a base address of 280H; switches 1 and 3 are in the OFF position and switches 2, 4, 5, 6, and 7 are in the ON position.

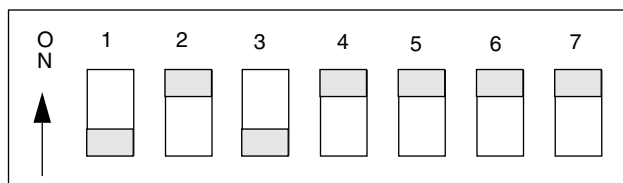

Figure 3-5. Setting the Base Address

Table 3-1 lists I/O addresses commonly used by IBM PC/XT, AT, and compatible computers. Determine an even boundary of eight I/O addresses within the range of 000H to 3F8H that is not being used by another resource in your system (including another DAS-8 Series board), and set the switches to the appropriate base address.

Table 3-1. I/O Address Map (000H to 3FFH)

| Address Range | Use |
|----------------------|-------------------------------------|
| 000H to 00FH | 8237 DMA #1 |
| 020H to 021H | 8259 PIC #1 |
| 040H to 043H | 8253 timer |
| 060H to 063H | 8255 PPI (XT) |
| 060H to 064H | 8742 controller (AT) |
| 060H to 06FH | 8042 keyboard controller |
| 070H to 071H | CMOS RAM and NMI mask register (AT) |
| 080H to 08FH | DMA page registers |
| 0A0H to 0A1H | 8259 PIC #2 (AT) |
| 0A0H to 0AFH | NMI mask register (XT) |
| 0C0H to 0DFH | 8237 DMA #2 (AT - word-mapped) |
| 0F0H to 0FFH | 80287 numeric processor (AT) |
| 170H to 177H | Hard disk controller #1 |
| 1F0H to 1F8H | Hard disk controller #2 |
| 1F0H to 1FFH | Hard disk controller (AT) |
| 200H to 2FFH | Game/control |
| 210H to 21FH | Expansion unit (XT) |
| 238H to 23BH | Bus mouse |
| 23CH to 23FH | Alternate bus mouse |
| 278H to 27FH | Parallel printer |
| 2B0H to 2DFH | EGA |
| 2E0H to 2EFH | GPIB (AT) |

Table 3-1. I/O Address Map (000H to 3FFH) (cont.)

| Address Range | Use |
|----------------------|---------------------------|
| 2E8H to 2EFH | Serial port |
| 2F8H to 2FFH | Serial port |
| 300H to 31FH | Prototype card |
| 320H to 32FH | Hard disk (XT) |
| 370H to 377H | Floppy disk controller #2 |
| 378H to 37FH | Parallel printer |
| 380H to 38FH | SDLC |
| 3A0H to 3AFH | SDLC |
| 3B0H to 3BBH | MDA |
| 3BCH to 3BFH | Parallel printer |
| 3C0H to 3CFH | VGA EGA |
| 3D0H to 3DFH | CGA |
| 3E8H to 3EFH | Serial port |
| 3F0H to 3F7H | Floppy disk controller #1 |
| 3F8H to 3FFH | Serial port |

Notes: The Expansion Board Configuration for Keithley DAS-8 Series dialog in DriverLINX allows you to enable the expansion channels. Make sure that the switch settings match the settings you define in DriverLINX. Refer to the *DriverLINX Appendix F: Configuration and Implementation Notes—Keithley DAS-8* manual.

On models DAS-8/PGA(G2) and DAS-8/AO, using a multiplexer requires setting the associated base channel's switch to single-ended.

The DriverLINX Analog Input subsystem has eight analog input single-ended or differential signal connections depending on the model of your DAS-8 series board. DriverLINX maps these signals to Logical Channels. DriverLINX uses several of these control connections for external clock, trigger, and gating inputs. Refer to the *DriverLINX Appendix F: Configuration and Implementation Notes—Keithley DAS-8* manual.

All DAS-8 Series boards have eight analog input channels. On DAS-8/PGA(G2) and DAS-8/AO models, you can switch each channel to differential or single-ended. The switch setting affects only the connections for the channel. DriverLINX grays out this property in the configuration dialog.

Setting the Input Configuration

DAS-8/PGA(G2) and DAS-8/AO boards are shipped with the input configuration for all channels set to single-ended. If this is not appropriate for your application, you can reconfigure the input configuration on a channel-by-channel basis using the input configuration switch block (labeled S2).

Note: The default input configuration in the DriverLINX configuration file is also single-ended for all channels. Make sure that the switch settings match the settings you establish in DriverLINX.

The input configuration switch block contains eight switches, labeled 1 through 8. Switch 1 corresponds to channel 0; switch 2 corresponds to channel 1, and so on. The location of the input configuration switch block on the DAS-8/PGA(G2) board is shown in Figure 3-3 and for the DAS-8/AO is shown in Figure 3-4.

You place a switch in the ON position (single-ended) by sliding the switch toward the top (numbered side) of the switch block. You place a switch in the OFF position (differential) by sliding the switch toward the bottom (unnumbered side) of the switch block.

Figure 3-6 illustrates the setting for channels 0, 5, and 7 configured as single-ended (switches 1, 6, and 8 are in the ON position) and channels 1, 2, 3, 4, and 6 configured as differential (switches 2, 3, 4, 5, and 7 are in the OFF position).

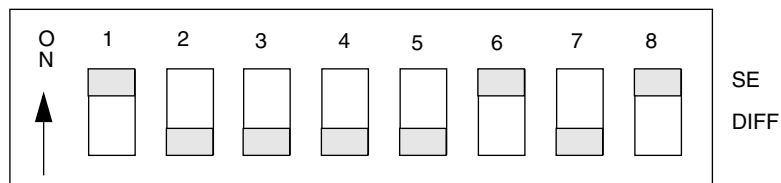

Figure 3-6. Setting the Input Configuration

Notes: Since DAS-8 and DAS-8/LT boards always use a single-ended input configuration, they do not contain an input configuration switch block.

Setting the Interrupt Level

DAS-8 Series boards are shipped with interrupts disabled. If you want to use interrupts, you must set an appropriate interrupt level using jumper block J2.

Note: DriverLINX modes specify preferred hardware data transfer techniques: foreground or synchronous modes, background or asynchronous modes. DriverLINX supports three modes with the DAS-800 Series for its commands: polled mode, interrupt mode, and other mode. Refer to the *DriverLINX Appendix F: Configuration and Implementation Notes for Keithley DAS-8* manual.

If you intend to acquire data in the background, you must enable interrupts by setting an interrupt level.

Jumper block J2 contains seven pairs of jumper posts, labeled 2, 3, 4, 5, 6, 7, and X (disabled). You set the interrupt level by placing the supplied jumper clip over the appropriate posts. Note that you can set only one interrupt level at a time.

Figure 3-7 illustrates the setting for interrupt level 5; the jumper clip is over the posts labeled 5.

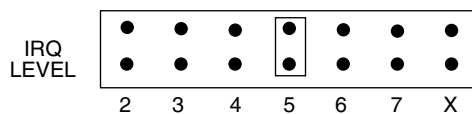

Figure 3-7. Setting the Interrupt Level

Table 3-2 lists interrupt levels commonly used by IBM PC and compatible computers. Select an interrupt level that is not being used by another resource in your system (including another DAS-8 Series board), and set the jumper to the appropriate interrupt level. It is recommended that you select interrupt level 3, 4, 5, or 7, if available.

Table 3-2. Interrupt Levels

| Level | Use |
|--------------|--|
| 2 | Reserved (XT), interrupts 8 to 15 (AT) |
| 3 | Serial port COM2 or SDLC |
| 4 | Serial port COM1 or SDLC |
| 5 | Hard disk (XT), LPT (AT) |
| 6 | Floppy disk |
| 7 | LPT |

Analog Output Voltage Range Adjustments (DAS-8/AO Only)

Switches S3 and S4 are the Analog Output Range switches for D/A1 and D/A0, respectively. Jumpers J6 and J7 set the D/A outputs into either Voltage Output Mode or 4-20mA Current Output Mode. Settings for these components are as shown in Figure 3-8.

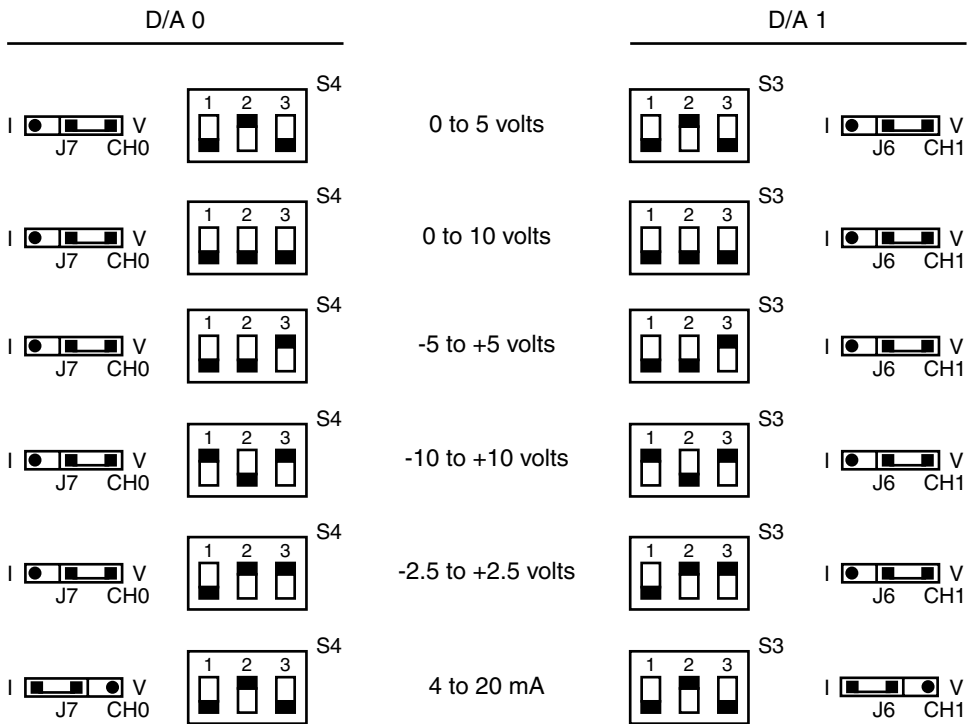

Figure 3-8. Setting the D/A Output Switches and Jumpers

D/A Output Channel Update (DAS-8/AO Only)

Switch S5 determines whether the two D/A outputs will be updated independently (NORM) or simultaneously (SIM). Independent updates are the normal mode, while simultaneous updates facilitate synchronization. Refer to Figure 3-4.

Wait-State Setting (DAS-8/AO Only)

Jumper J3 allows the board to be set for a Wait State. A wait state may be required when the board is used in computers whose bus speeds are greater than 8MHz. Placing the jumper on the OFF side disables the wait state. Refer to Figure 3-4.

Clock Select (DAS-8/LT Only)

Jumper J3 sets the board for the 1.000MHz (internal) or PC system (external) clock. Refer to Figure 3-2.

Clock

The input to the counter/timers used for A/D timing varies. The DAS-8 uses the PC bus clock while the DAS8-PGA and DAS-8/AO have an on-board 1MHz crystal oscillator. The frequency of the PC bus may be determined automatically as described below.

Custom Clock Frequencies

For timing, the DAS-8 Series uses the clock signal on the PC I/O bus or an on-board crystal oscillator. While the original IBM PC XT and compatibles always had a 2.384MHz bus clock, ISA and EISA bus machines have no accepted standard for PC bus clock. On many machines, the clock frequency is one-half the CPU clock frequency while, on others, it is adjustable using motherboard jumpers or advanced BIOS setup options. Few manufacturers provide this information in their documentation. This frequency, however, can be measured by DriverLINX using the 82C54 timer/counters on the DAS-8.

To measure the PC bus clock frequency, DriverLINX requires that Counters 1 and 2 be chained together using an external jumper. To chain the counters, connect Counter 2 Out [6] to Counter 1 IN [4] on the DAS-8 external connector.

Then, using DriverLINX, select the Counter/Timer Section in the Configuration Dialog Box. Choosing Custom Clock in the drop-down list of the Resolution combo-box displays the Custom Clock Frequency Dialog Box. Selecting Measure will start a 30-second measuring interval for determination of the PC bus clock frequency. The frequency box will update every second with the currently measured frequency. The measuring interval may be stopped at any time using the Stop pushbutton. The displayed frequency is added to the Resolution list box by selecting OK, or the measurement can be abandoned by selecting Cancel. The displayed frequency may be edited manually by selecting the numbers in the edit box and typing a new value for the selected digits.

4–20mA Current Loops

Process control current-loop transducers interface easily with DAS-8 and DAS-8/LT by adding a suitable shunt resistor across the input. Since the maximum current is 20mA and the maximum input range of a DAS-8 is +5V, a 250-ohm precision shunt resistor is required. The DAS-8/PGA(G2) and DAS-8/AO default range is also $\pm 5V$, so that this method also works here. The resistor should be of low temperature-coefficient metal film or wirewound construction for stability with time and temperature.

Using this interface, the 4–20mA working range of the current loop corresponds to 1638 bits of input, a resolution of about 0.06%.

The Reference (DAS-8 and DAS-8/LT Only)

The DAS-8 and DAS-8/LT provide a +10V A/D voltage reference (V_{ref}). It may be used for offsetting signals, but should not be heavily loaded. The maximum available output current is 2mA. Since this reference is shared by the A/D, any overload or shorting of the reference will affect the scaling of the A/D.

Interface to Transducers, Thermocouples, etc.

Low-level transducers such as thermocouples and strain gage bridges (load cells, pressure/force transducers) require amplification before applying to the high level DAS-8 series board inputs. The EXP-16 expansion multiplexer incorporates an instrumentation amplifier that can provide stable amplification. It also includes circuitry that allows cold-junction compensation of thermocouples. EXP-16 handles most interfacing requirements to DC output transducers and also includes spaces for filters, shunts, and attenuators.

For inexpensive temperature measurement in the -50 to $+125$ degree Celsius range, semiconductor temperature transducers are a good choice. The most popular types are the AD590 (Analog Devices), which behave like a constant-current source with an output of $273\mu\text{A}$ at 0°C and a scaling of $1\mu\text{A}/^\circ\text{C}$. The LM335 (National Semiconductor) has an output of 2.73 volts at 0°C and a temperature coefficient of $10\text{mV}/^\circ\text{C}$. Both of these devices can be powered from the $+12\text{V}$ available from the computer and directly interfaced to DAS-8 Series boards.

For measuring high temperatures (up to 1800°C or more), thermocouples are the most satisfactory solution. The base metal thermocouples, Types J, K, T, and E have outputs around $40\mu\text{V}/^\circ\text{C}$, while the platinum and tungsten types are generally used for the highest temperature measurement. Types S, B, and R tend to have lower outputs in the 6 to $12\mu\text{V}/^\circ\text{C}$ range. A further complication encountered in the use of thermocouples is the cold-junction compensation.

Where the thermocouple wire is terminated to the copper DAS-8 Series connections, a second thermocouple junction is formed by the two dissimilar metals. As the temperature of this connection varies, an error is introduced. The error can be mathematically compensated for by sensing the connector temperature using a semiconductor sensor on another channel and correcting the thermocouple readings using software. This is required only at the highest levels of accuracy, since in most cases connector temperature (usually room temperature) varies little.

DriverLINX has a Windows Dynamic Link Library (DLL) that you can use to perform thermocouple linearization. This DLL exports a function that you can use with most programming languages for converting the voltage output of Type B, E, J, K, R, S, and T thermocouples to temperature. The DriverLINX function, Volt2Temp, uses linear interpolation in a lookup table to convert voltages into temperatures.

Since the lookup table data is based on a cold junction temperature of 25°C, the input voltage needs to be corrected for the cold-junction temperature at which the measurement was obtained with the following formula:

$$V_{\text{corr}} = V_x + \text{offset} + (\text{CJCTemp} - 25) \text{ slope}$$

where V_x is the input voltage and V_{corr} is the corrected voltage (both in millivolts), CJCTemp is the measured temperature (in C°) of the cold junction, and slope and offset are data in the lookup table.

The Volt2Temp function assumes that the temperature values between adjacent points in the table are linear over voltage so it can use linear interpolation to calculate the temperature.

First, the function searches the lookup table for the nearest table voltage, V_1 , which is less than or equal to the input voltage, V_x , and retrieves the corresponding temperature value, t_1 . Then it retrieves the next voltage-temperature values, V_2 , and t_2 , in the lookup table to calculate the temperature, t_x , corresponding to the corrected input voltage, V_x .

Application Precautions

Unavoidably, data acquisition systems are intimately tied to the computer. Because of this, it is VERY IMPORTANT that signal inputs NOT be mixed with AC line current. As an aid to avoiding this problem:

1. Avoid direct connections to the AC line.
2. Ensure all signal wire connections are tight and sound to avoid shorts to high voltages.
3. Use isolation amplifiers and transformers where necessary to ensure isolation.

There are two ground connections (DIG. COM. and L.L. GND.) on the rear connector (DAS-8 Series boards implement the L.L. GND. only when in the single-ended input mode). Digital common is the noisy or “dirty” ground that is meant to carry all digital signal and heavy current (power supply). Low level ground is the signal ground for all analog input functions. It is only meant to carry signal currents (less than a few mA) and is the ground reference for the A/D channels. Because of connector contact resistance and cable resistance, there may be several millivolts difference between these two grounds even though they are eventually connected to each other, the computer, and power line grounds on the DAS-8 Series board.

Installing and Configuring DriverLINX for DAS-8 Series Boards

Important: As a precaution against a system crash the first time you install and test any new hardware, you should exit all other programs and, if you use a disk cache, disable write caching. If the system does crash and you're using disk compression software or a disk cache utility, as a precaution after any crash, run the utility that checks the directory structures.

This section describes how to install the DAS-8 Series standard software package. The contents of these software packages are described as follows:

- **DAS-8 Series standard software package** — Shipped with DAS-8 Series boards. Includes DriverLINX for Microsoft Windows and function libraries for writing application programs such as Microsoft Visual C++; Microsoft Visual Basic; Borland Delphi; utility programs; and language-specific example programs.
- **DriverLINX** — the high-performance real-time data-acquisition device drivers for Windows application development includes:
 - *DriverLINX API DLLs and drivers supporting the DAS-8 Series hardware*
 - *Learn DriverLINX* - an interactive learning and demonstration program for DriverLINX that includes a Digital Storage Oscilloscope
 - *Source Code* - for the sample programs
 - *DriverLINX On-line Help System* - provides immediate help as you operate DriverLINX
 - *Supplemental Documentation* - on DriverLINX installation and configuration; analog and digital I/O programming; counter/timer programming; technical reference; and information specific to the DAS-8 Series hardware

Note: DAS-8 Series boards are not compatible with Windows NT or WIN 2000.

Installing the DAS-8 Series Standard Software Package

Note: Important — Before you begin installing any hardware or software for the DAS-8, read the *DriverLINX Installation and Configuration Guide* and the *DriverLINX Appendix F: Configuration and Implementation Notes for Keithley DAS-8* manuals that are packaged with the DriverLINX software. They are accessed from the DriverLINX CD-ROM after you have installed Adobe Acrobat.

Before Installing DriverLINX

1. Inventory your DAS-8 board's configuration settings.
2. Determine the resources your DAS-8 Series board requires.
3. Inventory your computer's resources already allocated to other installed devices.
4. Determine whether your computer has sufficient resources for your DAS-8 board.
5. Determine whether your DAS-8 board can use your computer's free resources.
6. Set any jumpers/switches to configure your DAS-8 board to use your computer's free resources.
7. Set any other jumpers/switches to configure your DAS-8 board the way you want.
8. Install your DAS-8 board into an appropriate free slot in your computer.

Selecting the DriverLINX Components to Install

For your convenience in installing and uninstalling just the DriverLINX components you need, the DriverLINX CD Browser will assist you in selecting the components to install:

- **Install Drivers** - This required component installs only the files you need for configuring your hardware and running third-party data-acquisition applications that require DriverLINX.
- **Install Interfaces** - This optional component installs the files and example programs that you will need to develop custom applications for DriverLINX using C/C++, Visual Basic, Delphi, and LabVIEW.
- **Install Documentation** - This optional component installs electronic documentation for DriverLINX that you can read, search, and print using the Adobe Acrobat Reader.
- **Install Acrobat** - This optional component installs the Adobe Acrobat Reader for the DriverLINX electronic documentation.

Installing DriverLINX

1. Insert the DriverLINX CD-ROM into your computer's CD-ROM Drive.
2. Start the DriverLINX setup program. On most systems, wait a few seconds for automatic startup. Otherwise, run the setup.exe program from the CD-ROM.
3. The DriverLINX CD-ROM Browser Map window appears on the screen. Click 'Install Drivers,' and follow the series of on-screen instructions.

Note: To display an explanation of a menu option on the DriverLINX CD browser map that appears next and on subsequent setup screens, place the mouse pointer over the menu item. A star next to a menu item means that the item was selected previously.

4. Select 'Read Me First,' and follow the instructions.
5. Select 'Install Documentation.' If you do not have Adobe Acrobat installed on your computer, install it by selecting 'Install Adobe Acrobat.'
6. Open the manuals appropriate to the DAS-800 installation and read them before installing your DAS-800 board or configuring DriverLINX:
 - *DriverLINX Installation and Configuration*
 - *Appendix F: Configuration and Implementation Notes — Keithley DAS-8*
 - *DriverLINX Technical Reference Manual*
 - *DriverLINX Analog I/O Programming Guide*
 - *DriverLINX Digital I/O Programming Guide*
 - *DriverLINX Counter/Timer Programming Guide*
 - *Appendix, I/O Port, Interrupt, and DMA Channel Usage*
 - Other manuals appropriate to your installation

Configuration with DriverLINX

Follow the DriverLINX on-screen instructions for installation of drivers and interfaces. Refer to the *DriverLINX Installation and Configuration Guide* and *DriverLINX Appendix F: Configuration and Implementation Notes* — Keithley DAS-8 manuals.

Before you configure DriverLINX for operation with the DAS-8 Series board, you must specify the base address, interrupt level, and input configuration by setting switches on the board.

Installing the Board

Before installing a DAS-8 Series board in your computer, make sure that the switches and jumpers on the board are set appropriately and that the jumper and switch settings match the settings you configure in DriverLINX.

Caution: Installing or removing a board with the power ON can cause damage to your computer.

To install the board, perform the following steps:

1. Turn power to the computer and all attached equipment OFF.
2. Remove the computer chassis cover.

Select an available slot. The DAS-8 or DAS-8/LT requires a single, short slot; the DAS-8/PGA(G2) requires a single, 1/2-slot; the DAS-8/AO requires a full slot.

Caution: Be careful when installing a DAS-8/AO board that requires a full slot. Some motherboards have components that extend into this space and may cause interference.

3. Loosen and remove the screw at the top of the blank adapter plate, then slide the plate up and out to remove.

4. Insert and secure the board connector in the selected slot.
5. Replace the computer chassis cover.
6. Plug in all cords and cables.
7. Turn power to the computer ON.

After you install the DAS-8 Series board in the computer, you can attach an expansion board, if necessary, and wire the appropriate signals to the board; refer to Section 4 for information. Before writing your application program, you can test the functions of the DAS-8 Series board using the DriverLINX AIO Panel or Test Panel for testing your DriverLINX installation and configuration; verifying signal inputs to the DAS-8 Series board; sending test signals to external devices.

Refer to the documentation provided with your computer for more information on installing boards.

Configuring DriverLINX

After you have successfully installed the DAS-8 Series board in your computer, start Windows to start DriverLINX. See the documentation provided on the DriverLINX CD-ROM; especially the *DriverLINX Installation and Configuration Guide* and the *DriverLINX Appendix F: Configuration and Implementation Notes:Keithley DAS-8* manuals.

Run “Learn DriverLINX” (LearnDL.exe) from the DriverLINX program group to tell DriverLINX how you configured your DAS-8 Series board and to verify that everything is properly installed and configured.

1. Start Windows as you normally would and select the Program Manager window. Install DriverLINX if you have not previously done so.

2. Either select the “Learn DriverLINX” icon created when you installed DriverLINX or enter “<drive>:/DRVLNX/LEARNDL” in the Command Line edit box. The command line edit box is activated by selecting the Run... option. <drive> is the letter of the hard disk drive where DriverLINX is installed.
3. Immediately after loading Learn DL, the Open DriverLINX DLL dialog box appears. Select the name of the hardware-specific DLL from the list for your DAS-8 board. The name is an abbreviation of the board’s model number.
4. From the main menu bar of Learn DL, select the Device menu and choose Select....
5. Select the Logical Device you wish to configure and then click on the OK button (return).
6. Again select the Device menu and then choose the Configure... option to display the Device Configuration Dialog Box.
7. From the Model list, select the model name for the DAS-8 Series board you are configuring.
8. If the value displayed in the Address edit box is not correct, type the correct value into the box. You may enter the address in decimal or hexadecimal using the c-notation for hex, (that is, 768 decimal = 0x300 hexadecimal).
9. Choose the correct options for the Analog, digital, and Counter/Timer Sections by first clicking on the appropriate radio button in the middle of the dialog box and then completing the group of dialog fields in the lower third of the dialog box. Be sure to click on both the Input and Output radio buttons for the Analog and Digital groups to see all the dialog fields.
10. After you have made all your selections, save the configuration parameters by clicking on the OK button. This will create or update the configuration file in the Windows directory.

Editing a Configuration File

The configuration file, KMBDAS8.INI, can also be created or edited using a plain ASCII text editor, such as Notepad editor that comes with Windows. The layout and format of the configuration file is similar to the initialization files created by Windows and other Windows applications. See Appendix C.

All entries in the configuration file have the following form:

```
[logical device number]  
keyname=string
```

where “keyname” is the name of a field recognized by DriverLINX and “string” is the value for that field. The case of the letters in keyname and string is not significant.

A typical entry for logical device 0 in the configuration initialization file follows:

The string values recognized for the Vendor and Model keynames are

```
[Device 0]  
Vendor=Keithley  
Model=DAS-8  
Address=768  
A/D channels=8  
Min A/D volts=-5.0  
Max A/D volts=5.0  
IRQ=7  
DMA=-1  
Clock=4.15 MHz
```

defined in the DriverLINX API file, OEMCODES.H. Case is not significant for matching a string value. The numeric values must all be decimal or floating point.

The default address used by the DAS-8 is 768 decimal or 0x300 hex. If you have more than one Keithley device or another peripheral card at the same address, you will have to change the DIP switch settings for the device address on the board.

The DAS-8 A/D channels are configured as eight single-ended or differential analog inputs. DriverLINX does not distinguish between single-ended and differential inputs.

The minimum and maximum analog full-scale voltages at unity gain must be specified. For the DAS-8, the minimum and maximum voltages are fixed at ± 5 volts.

If hardware interrupts are not supported, select an IRQ value of -1 , otherwise an interrupt request level must be selected in the range of 2 to 7. Interrupt lines can be shared so long as two devices sharing an interrupt will not be used concurrently. A list of common hardware interrupt assignments is shown in Table 3-2.

DMA is not used by the DAS-8 Series. This item must either have the value -1 , or the option may be deleted from the file with a text editor.

4

Cabling and Wiring

This chapter describes how to attach accessory and expansion boards to a DAS-8 Series board, how to connect signals to a DAS-8 Series board, and how to synchronize conversions on multiple DAS-8 Series boards.

Note: Before you make any connections to a DAS-8 Series board, make sure that power to your computer and any accessories attached to the DAS-8 Series board are OFF.

Attaching Accessory and Expansion Boards

You attach an STC-37 screw terminal connector, STA-08 or STA-08PGA screw terminal accessory, or EXP-16, EXP-16/A, or EXP-GP expansion board to a DAS-8 Series board through the main I/O connector, a 37-pin, D-type connector that is labeled J2 on the board. The main I/O connector and its pin assignments on a DAS-8 board are shown in Figure 4-1; the main I/O connector and its pin assignments on a DAS-8/PGA(G2) board are shown in Figure 4-2; the main I/O connector and its pin assignments on a DAS-8/AO board are shown in Figure 4-3. Refer to Appendix B for a more detailed description of the pins.

Top of Board (Rear View)

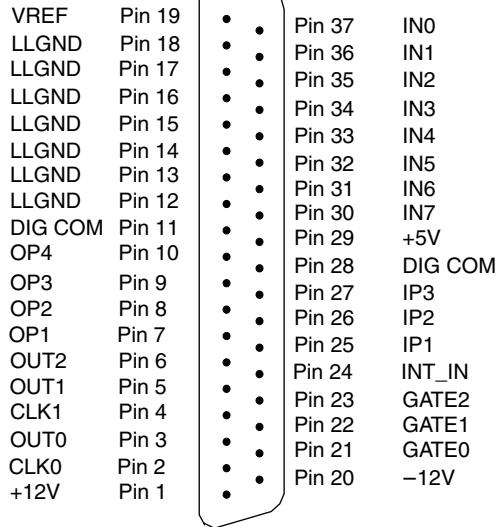

Figure 4-1. Main I/O Connector on a DAS-8 or TAS-8/LTBoard

Top of Board (Rear View)

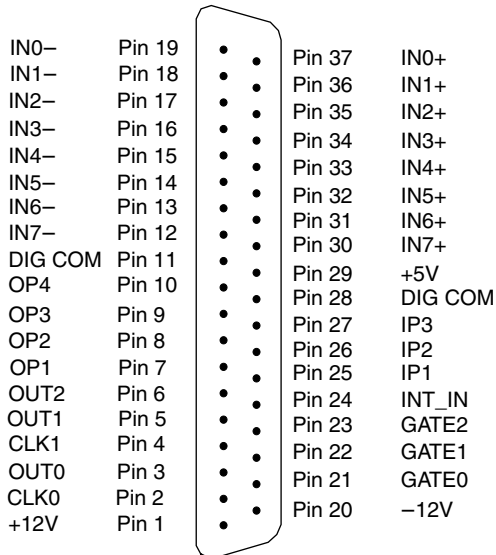

Figure 4-2. Main I/O Connector on a DAS-8/PGA(G2) Board

Top of Board (Rear View)

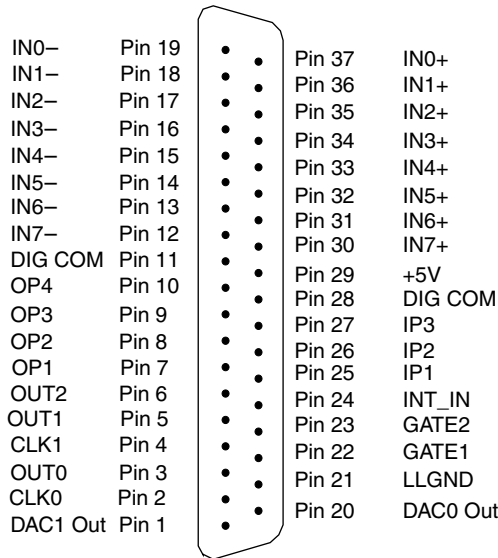

Figure 4-3. Main I/O Connector on a DAS-8/AO Board

You attach an STC-37 screw terminal connector directly to the main I/O connector on the DAS-8 Series board. You attach an STA-08 or STA-08PGA screw terminal accessory or an EXP-16, EXP-16/A, or EXP-GP expansion board to the main I/O connector on the DAS-8 Series board using either a C-1800 or S-1800 cable. The C-1800 is the unshielded version of the cable; the S-1800 is the shielded version of the cable.

Attaching an STC-37 Screw Terminal Connector

The screw terminals on the STC-37 screw terminal connector allow you to connect field wiring to a DAS-8 Series board. The screw terminals are labeled from 1 to 37 and correspond directly to the functions of the pins on the main I/O connector on the board. For example, since pin 24 is assigned to the external clock source, use screw terminal 24 to attach a hardware external clock. Refer to Appendix B for a complete list of pin assignments.

To connect an STC-37 to a DAS-8 Series board, directly attach the 37-pin connector on the STC-37 to the main I/O connector on the DAS-8 Series board. Figure 4-4 illustrates the connection of an STC-37 to a DAS-8 Series board.

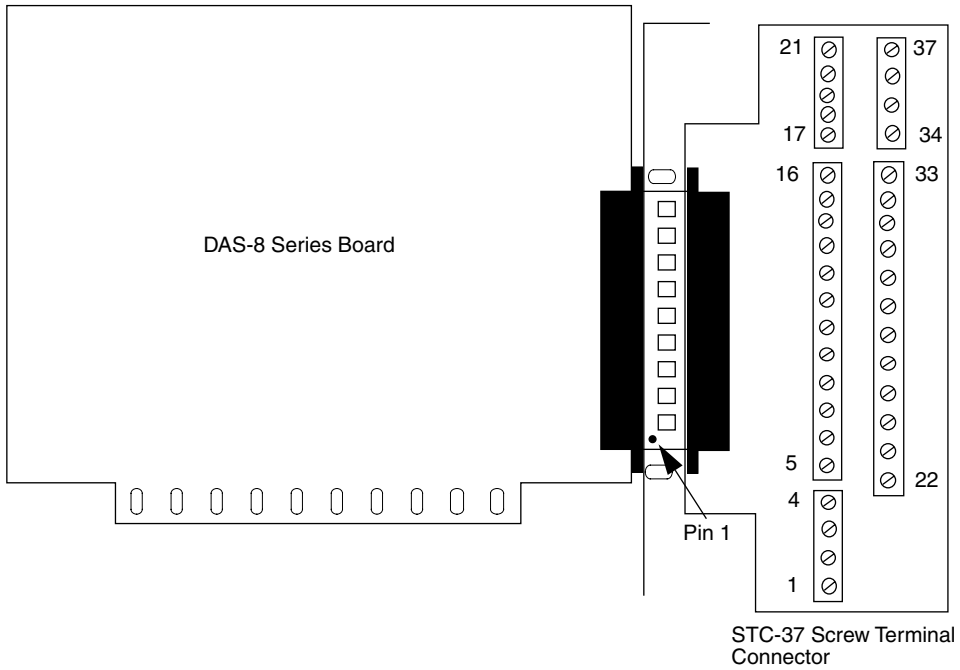

Figure 4-4. Attaching an STC-37 Screw Terminal Connector

Attaching an STA-08 / STA-08PGA Screw Terminal Accessory

The screw terminals on the STA-08 screw terminal accessory allow you to connect field wiring to a DAS-8 board; the screw terminals on the STA-08PGA screw terminal accessory allow you to connect field wiring to a DAS-8/PGA(G2) board. Each screw terminal is labeled with the name of the board function to which it is connected; the screw terminals correspond directly to the functions of the pins on the main I/O connector on the board.

To connect an STA-08/STA-08PGA to a DAS-8 Series board, attach one end of the S-1800 or C-1800 cable to the main I/O connector on the DAS-8 Series board and the other end of the cable to the J1 connector on the STA-08/STA-08PGA. Figure 4-5 illustrates the connection of an STA-08/STA-08PGA to a DAS-8 Series board.

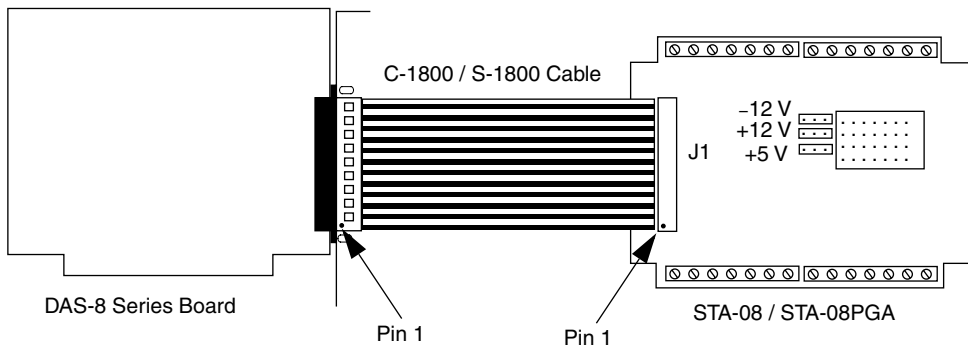

Figure 4-5. Attaching an STA-08/STA-08PGA Screw Terminal Accessory

Attaching an EXP-16 or EXP-16/A Expansion Board

Each EXP-16 or EXP-16/A expansion board provides up to 16 analog input channels (labeled 0 to 15). The EXP-16 and EXP-16/A provide three screw terminals for each channel: low-level ground (LL GND), positive input (CH n HI), and negative input (CH n LO), where n indicates the number of the channel.

To connect an EXP-16 or EXP-16/A to a DAS-8 Series board, attach one end of the S-1800 or C-1800 cable to the main I/O connector on the DAS-8 Series board and the other end of the cable to the J1 connector on the EXP-16 or EXP-16/A. Figure 4-6 illustrates the connection of an EXP-16 to a DAS-8 Series board.

Refer to the EXP-16 and EXP-16/A expansion board documentation for more information about these expansion boards.

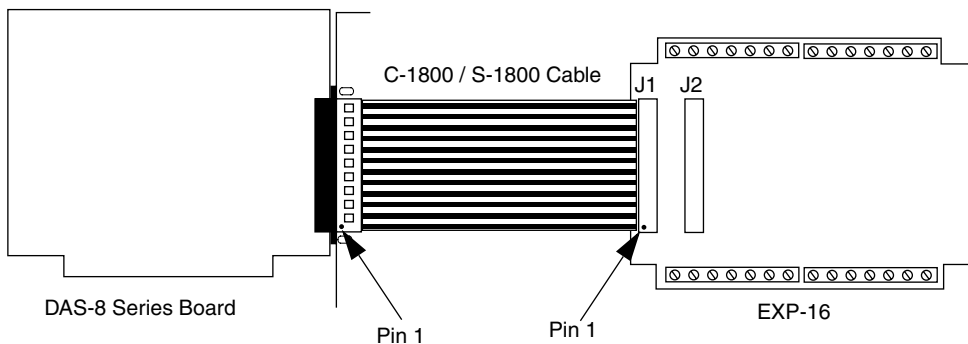

Figure 4-6. Attaching an EXP-16 or EXP-16/A Expansion Board

Attaching an EXP-GP Expansion Board

Each EXP-GP expansion board provides up to eight analog input channels (labeled 0 to 7). The EXP-GP provides six screw terminals for each channel: positive current excitation (+IEXC), positive input (+SENSE), negative voltage excitation (-P), negative current excitation (-IEXC), negative input (-SENSE), and positive voltage excitation (+P).

To connect an EXP-GP to a DAS-8 Series board, attach one end of the S-1800 or C-1800 cable to the main I/O connector on the DAS-8 Series board and the other end of the cable to the J1 connector on the EXP-GP. Figure 4-7 illustrates the connection of an EXP-GP to a DAS-8 Series board.

Refer to the EXP-GP expansion board documentation for more information about this expansion board.

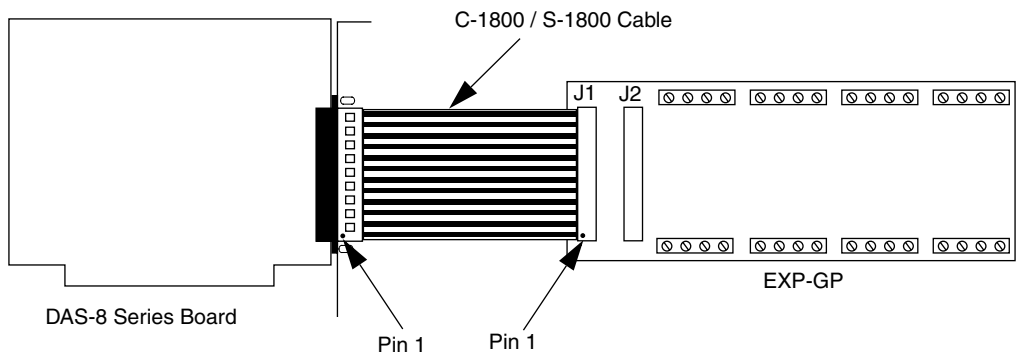

Figure 4-7. Attaching an EXP-GP Expansion Board

Attaching an MB Series Backplane

Refer to the *MB Series User's Guide* for information on connecting DAS-8 Series boards to MB Series backplanes.

Connecting Multiple Expansion Boards

You can daisy-chain up to eight EXP-16, EXP-16/A, and/or EXP-GP expansion boards to provide up to 128 analog input channels. You connect the first expansion board to the DAS-8 Series board by attaching one end of an S-1800 or C-1800 cable to the main I/O connector on the DAS-8 Series board and the other end of the cable to the J1 connector on the expansion board. To connect additional expansion boards, attach one end of an S-1800 or C-1800 cable to the J2 connector on the previous expansion board and the other end of the cable to the J1 connector on the next expansion board in the chain.

Note: Each EXP-16, EXP-16/A, or EXP-GP expansion board is associated with an analog input channel on the DAS-8 Series board. You specify the associated on-board channel by setting a jumper on the expansion board. Make sure that you use a unique jumper setting for each expansion board you are using. Refer to your expansion board documentation for more information.

You can use the J2 connector on the last expansion board in the chain to attach an STA-08/STA-08PGA screw terminal accessory. This allows you to access the remaining functions of the DAS-8 Series board.

Figure 4-8 illustrates how to connect two EXP-16 expansion boards, one EXP-GP expansion board, and an STA-08 screw terminal accessory to a DAS-8 board.

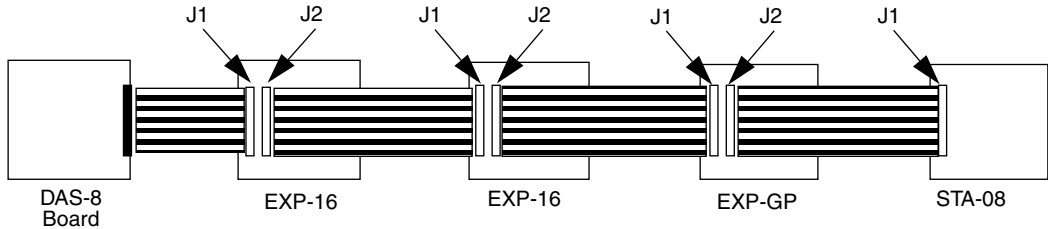

Figure 4-8. Connecting Multiple Expansion Boards

Note: You can also attach up to four MB-02 backplanes to a DAS-8 Series board using an STA-SCM8 screw terminal accessory and up to four C-2600 cables. Refer to the *MB Series User's Guide* for more information.

Connecting Signals

This section describes how to wire signals to a DAS-8 Series board.

Although the illustrations in this section show a direct connection to a pin on the main I/O connector, you will actually wire your signal to a screw terminal on an accessory or expansion board or to a user-supplied, female 37-pin D connector. Appendix B lists the functions associated with each pin on the main I/O connector.

The DAS-8 board contains both digital commons and low-level analog commons. Use a digital common for all digital signal returns and power supply returns; use a low-level analog common for all analog signal returns.

The DAS-8/PGA(G2) and DAS-8/AO boards contain digital commons, but no dedicated low-level analog commons. If you are using all eight analog input channels and all eight channels are configured for differential input, you must connect a bias return path to a digital common instead of a low-level analog common. If at least one channel is unused or configured for single-ended input, you can use the negative side of the channel as a low-level analog common.

When wiring analog input signals, it is recommended that you terminate all unused input channels to low-level ground; this prevents the internal amplifier circuitry from saturating if you select an unconnected input and ensures the accuracy of your data.

Connecting an Analog Input Signal to a Single-Ended Input

Figure 4-9 illustrates how to connect an analog input signal to single-ended analog input channel 0 on a DAS-8 Series board.

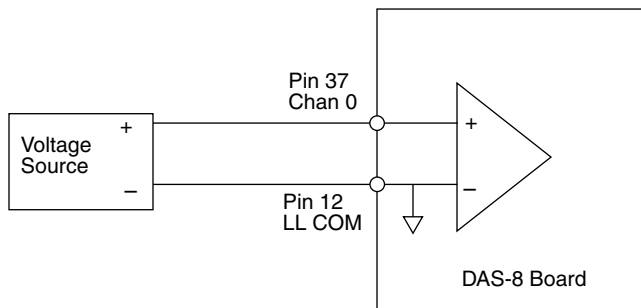

Figure 4-9. Single-Ended Input

Connecting an Analog Input Signal to a Differential Input

For differential input configurations, you must provide a bias current return path. If at least one channel is unused or configured for single-ended input, use the negative side of that channel as the low-level analog common; otherwise, use the digital common.

Figure 4-10 illustrates how to connect an analog input signal to differential analog input channel 0 on a DAS-8/PGA board for output resistances both less than and greater than 100Ω . Since analog input channel 7 is not used, the bias current return path is connected to the negative side of channel 7.

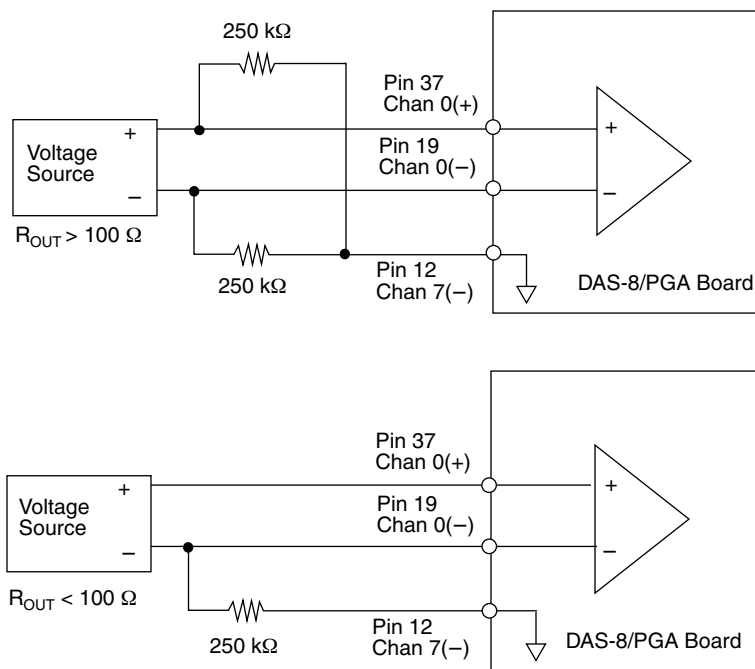

Figure 4-10. Differential Input

Note: For output resistances greater than 100Ω , it is recommended that the sum of the resistors used be at least 5,000 times greater than the source output resistor.

Connecting Analog Output Signal from a DAS-8/AO Board

This section contains information needed when wiring analog output signals from a DAS-8/AO board to your application.

Figure 4-11 illustrates how to connect a voltage output signal from a DAS-8/AO board to your application. Figure 4-12 illustrates how to connect a current output signal from a DAS-8.AO board to your application.

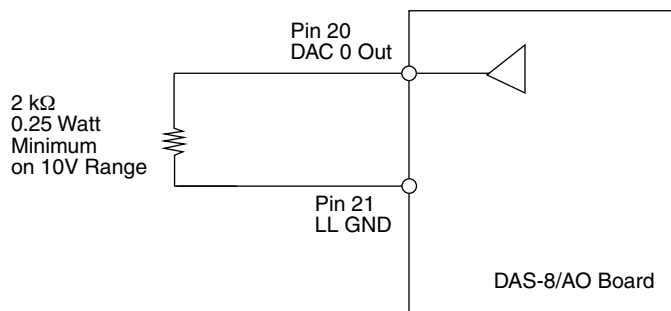

Figure 4-11. DAS-8/AO Voltage Output

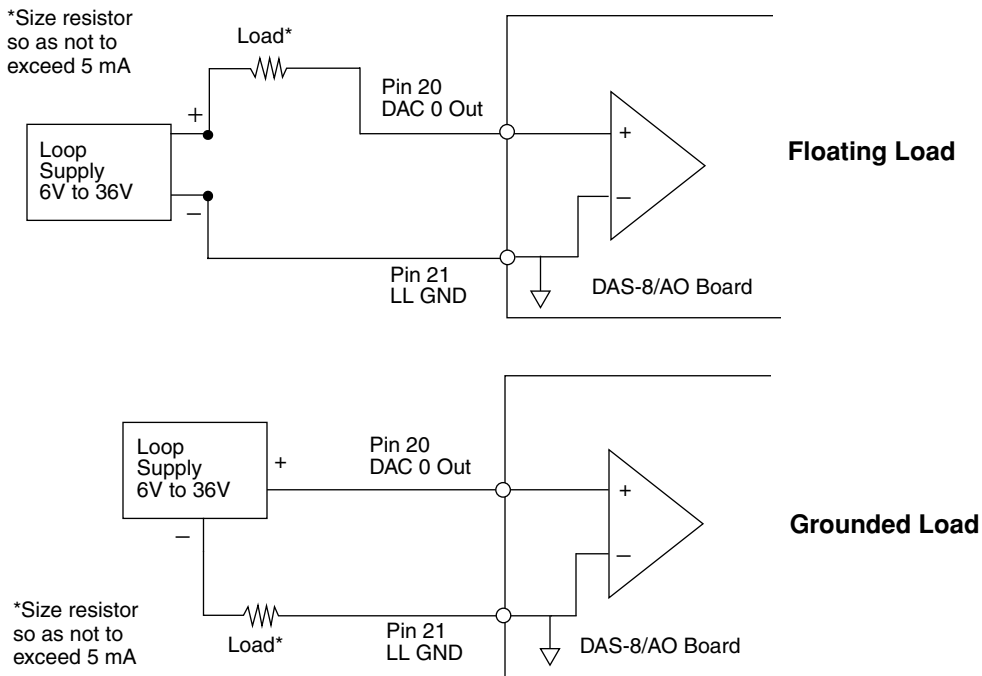

Figure 4-12. DAS-8/AO Current Output

Connecting Digital Signals

You can connect the following digital signals to a DAS-8 Series board:

- **Digital input signal** — Connect a digital input signal to the IP1, IP2, or IP3 pin (pin 25, 26, or 27) on the main I/O connector.
- **Digital output signal** — Connect a digital output signal to the OP1, OP2, OP3, or OP4 pin (pin 7, 8, 9, or 10) on the main I/O connector.
- **External conversion clock** — Connect an external conversion clock to the INT_IN pin (pin 24) on the main I/O connector.
- **Hardware digital trigger or hardware gate** — Connect a hardware digital trigger or hardware gate signal to the IP1 pin (pin 25) on the main I/O connector.
- **External interrupt** — Connect an external interrupt to the INT_IN pin (pin 24) on the main I/O connector.

Make sure that all digital signals are TTL-level compatible. Use the digital common as the return for all digital signals.

Caution: To prevent damage to DAS-8 Series boards, do not apply voltages exceeding TTL maximum levels (-0.5V to +5.5V) to digital input pins.

Connecting Counter/Timer I/O Signals

Refer to 82C54 documentation for information on connecting counter/timer I/O signals to the clock input pin, gate input pin, and output pin of any available counter/timers on a DAS-8 Series board. Table 2-2 lists several companies that provide documentation for the 82C54.

Synchronizing Conversions on Multiple Boards

You can use a hardware external clock source to synchronize conversions on multiple DAS-8 Series boards. In addition, you can use the output of the OUT1 pin (pin 5) on a DAS-8/PGA(G2) or DAS-8/AO board (acting as a timing master) to synchronize conversions on additional DAS-8 Series boards.

Figure 4-13 illustrates how you can synchronize conversions on multiple boards, using both an external clock source and a DAS-8/PGA/G2 board. Note that in both cases, boards 1, 2, and 3 must be configured to use an external clock.

Figure 4-14 illustrates the use of C/T0 on the 82C54 on board 1 to divide the rate of the master clock by the programmed count. This allows you to synchronize conversions on board 1 to a rate different from that of the master board. Note that when you use C/T0 to divide the rate of the master clock, C/T0 must be configured for counter/timer mode 2 (rate generator mode). Refer to Section 2, 82C54 Counter/Timer Circuitry, or to your 82C54 documentation for more information.

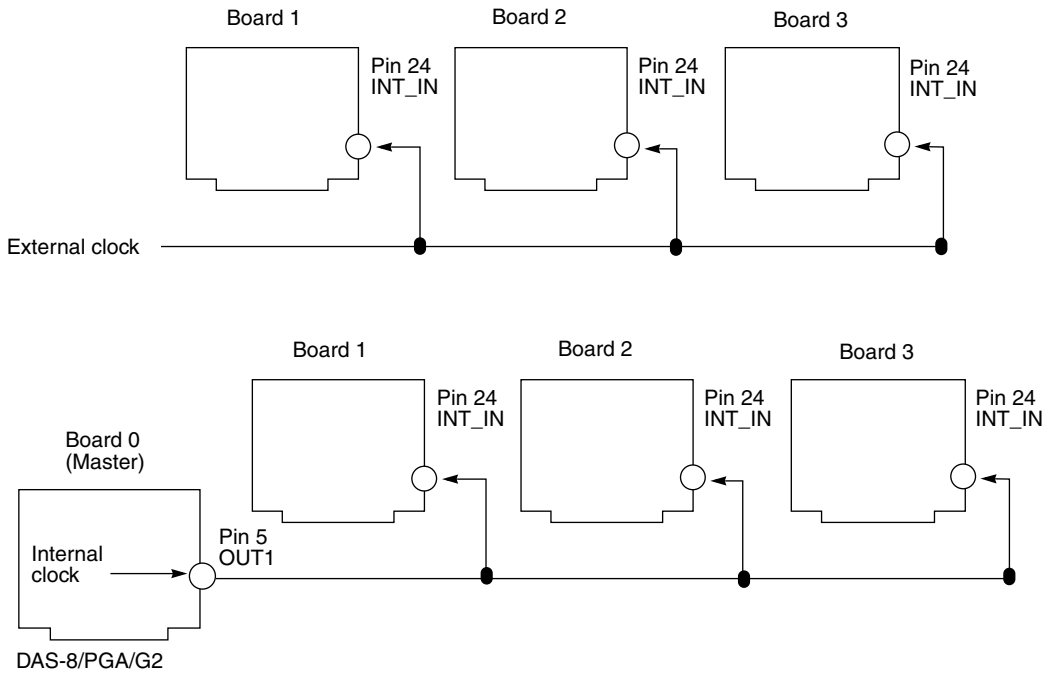

Figure 4-13. Synchronizing Conversions on Multiple Boards

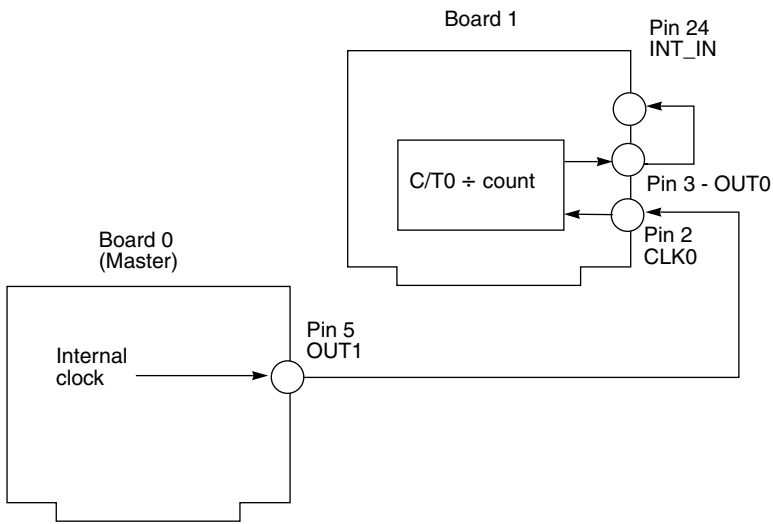

Figure 4-14. Dividing the Rate of the Master Clock

4–20mA Current Loops

Process control current-loop transducers interface easily with DAS-8 and DAS-8/LT by adding a suitable shunt resistor across the input. Since the maximum current is 20mA and the maximum input range of a DAS-8 is +5V, a 250-ohm precision shunt resistor is required. The DAS-8/PGA(G2) and DAS-8/AO default range is also $\pm 5V$, so that this method also works here. The resistor should be of low temperature-coefficient metal film or wirewound construction for stability with time and temperature.

Using this interface, the 4–20mA working range of the current loop corresponds to 1638 bits of input, a resolution of about 0.06%.

The Reference (DAS-8 and DAS-8/LT Only)

The DAS-8 and DAS-8/LT provide a +10V A/D voltage reference (V_{ref}). It may be used for offsetting signals, but should not be heavily loaded. The maximum available output current is 2mA. Since this reference is shared by the A/D, any overload or shorting of the reference will affect the scaling of the A/D.

5

Calibration

The analog input circuitry of DAS-8 Series boards is calibrated in the factory. It is recommended that you check the calibration every six months and recalibrate the board, if necessary.

Note: For channels using gains other than 1, the board maintains the initial calibration within an accuracy of $\pm 0.05\%$. In applications where a single gain (other than 1) is used for all channels, you can achieve better accuracy by calibrating the board at the selected gain.

The following sections provide the information you need to calibrate DAS-8 Series boards.

Equipment Required

You need the following equipment to calibrate a DAS-8 Series board:

- A digital voltmeter accurate to 6 1/2 digits on its $\pm 10\text{Vdc}$ range, such as the Keithley Model 196.
- A calibrated DC voltage source with an output voltage range of $\pm 10\text{V}$, such as the EDC 520 from Electronic Development Corporation.

Note: If a calibrated DC voltage source is not available, use a variable DC voltage source and set its output voltage level using the voltmeter.

- An STA-08 or STA-08PGA screw terminal accessory and C-1800 cable, or an STC-37 screw terminal connector.

Note: Do not attempt to calibrate a DAS-8 Series board unless your equipment is of the required accuracy.

Potentiometers

DAS-8 Series boards contain potentiometers, which you must adjust when calibrating the board. The DAS-8 board contains two potentiometers: R1 (full scale) and R2 (offset); see Figure 5-2. The DAS-8/LT board contains two potentiometers: R3 (full scale) and R4 (offset); see Figure 5-2.

The DAS-8/PGA(G2) boards contain four potentiometers: R1 (offset), R2 (full scale), R3 (unipolar fullscale), and R4 (unipolar offset); see Figure 5-3.

The DAS-8/AO boards contain ten potentiometers: R1 (offset), R2 (full scale), R3 (unipolar full scale), and R4 (unipolar offset), R33 (analog output gain adjustment for DA1) R 36 (analog output gain adjustment for DA0), R34 (analog output zero adjustment for DA1), R37 (analog output zero adjustment for DA0), R32 (4-20mA adjustment for DA1), and R35 (4-20mA adjustment for DA0) see Figure 5-4.

In addition, on DAS-8/PGA(G2) and DAS-8/AO boards, you must measure the current between two test points (TP1 and TP2) when calibrating the board.

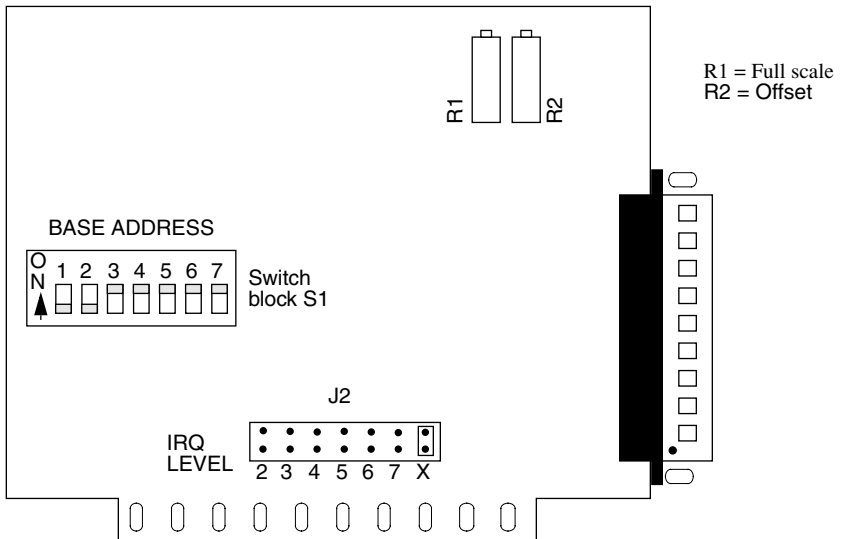

Figure 5-1. Potentiometers (DAS-8)

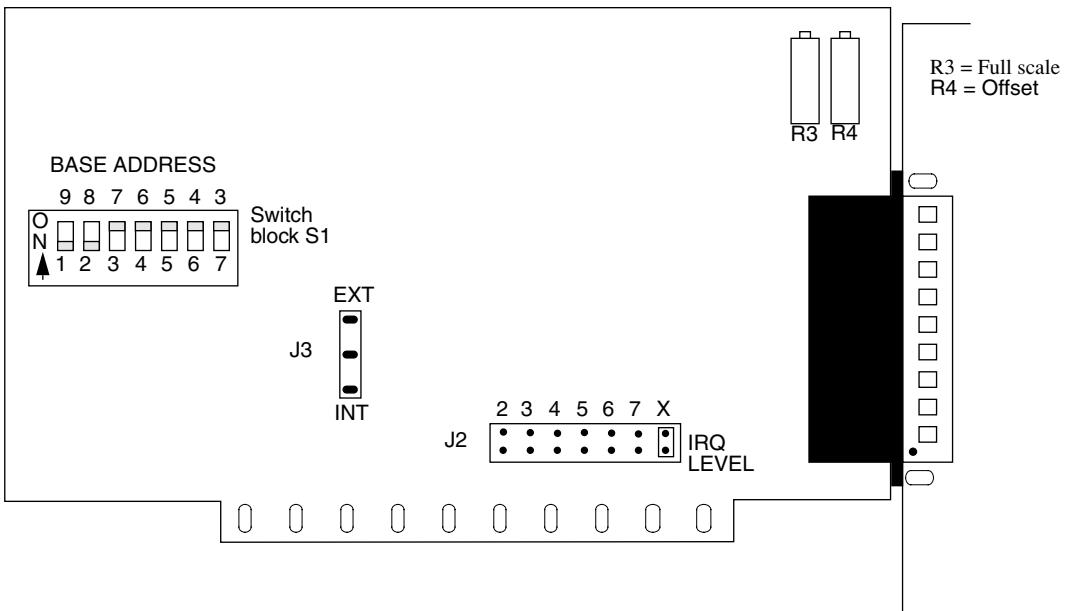

Figure 5-2. Potentiometers (DAS-8/LT)

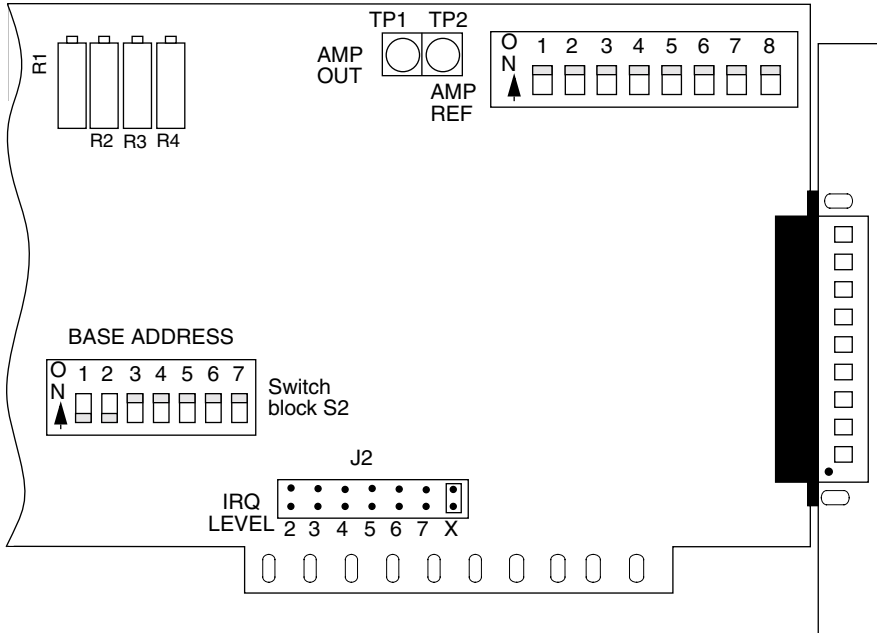

Figure 5-3. Potentiometers [DAS-8/PGA(G2)]

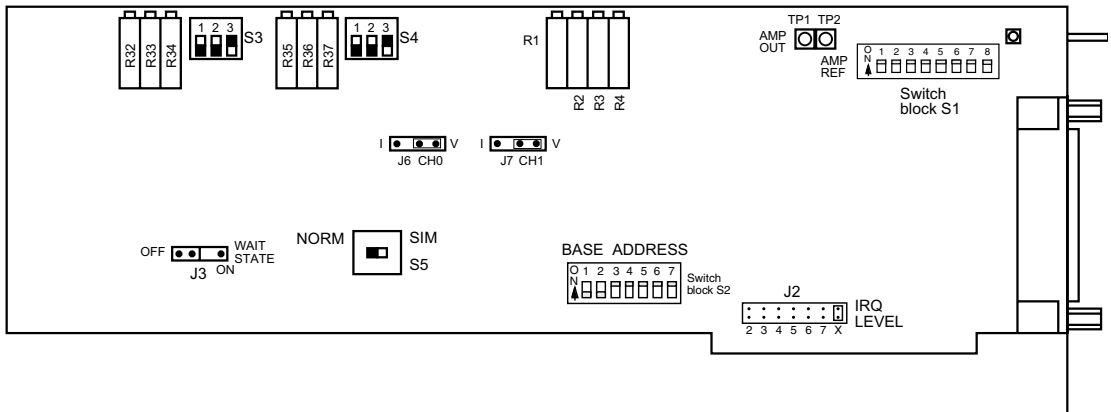

Figure 5-4. Potentiometers (DAS-8/AO)

Troubleshooting

If your DAS-8 Series board is not operating properly, use the information in this chapter to help you isolate the problem. If the problem appears serious enough to require technical support, refer to Technical Support on page 6-5 for information on how to contact an applications engineer.

If you encounter a problem with a DAS-8 Series board, use the instructions in this section to isolate the cause of the problem before calling Keithley for technical support.

Device initialization error messages

During device initialization, DriverLINX performs a thorough test of all possible subsystems on the DAS-8 Series board as well as the computer interface. If DriverLINX detects any problems or unexpected responses, it reports an error message to help isolate the problem. The device initialization error messages fall into three basic categories:

- **Device not found** — Board address does not match hardware setting or conflicts with another board. Verify the board's address settings. Also, don't confuse hexadecimal with decimal addresses in the DriverLINX Device Configure dialog box.
- **Invalid IRQ level or Invalid DMA level** — Selected level does not match hardware setting, conflicts with another board's IRQ/DMA levels, or is dedicated to the computer's internal functions (COM port, disk drive controller, network adapter, etc.)
- **Hardware does not match configuration** — Operating mode/range switch or jumper setting does not match selection(s) made in the DriverLINX Device Configuration dialog box.

Problem Isolation

If you encounter a problem with a DAS-8 Series board, perform the following steps to determine whether the problem is in the computer, in the DAS-8 Series board, or in the I/O circuitry:

1. Remove power connections to the host computer.
2. Unplug the accessory connector(s) or cable(s) from the DAS-8 Series board(s), keeping the connections intact on the accessory or expansion board(s).
3. Remove the DAS-8 Series board(s) from the computer and visually check for damage. If a board is obviously damaged, refer to Technical Support on page 6-5 for information on returning the board.
4. With the DAS-8 Series board(s) out of the computer, check the computer for proper operation. Power up the computer and perform any necessary diagnostics.
5. When you are sure that the computer is operating properly, remove computer power again, and install a DAS-8 Series board that you know is functional. Do not make any I/O connections.
6. Apply computer power and check operation with the functional DAS-8 Series board in place. This test checks the computer accessory slot. If you are using more than one DAS-8 Series board, check the other slots you are using.
7. If the accessory slots are functional, check the I/O hookups. Connect the accessory and expansion boards, one at a time, and check operation.
8. If operation is normal, the problem is in the DAS-8 Series board(s) originally in the computer. Try the DAS-8 Series board(s) one at a time in the computer to determine which is faulty. Use the troubleshooting information in the next section to try to isolate the problem.
9. If you cannot isolate the problem, refer to Technical Support on page 6-5 for instructions on getting technical support.

Troubleshooting Table

Table 6-1 lists general symptoms and possible solutions for problems with DAS-8 Series boards. If your board is not operating properly after using this information, refer to Technical Support on page 6-5 for instructions on getting technical support.

Table 6-1. Troubleshooting Information

| Symptom | Possible Cause | Possible Solution |
|------------------------|---|---|
| Board does not respond | Base address is unacceptable. | Make sure that the base address specified in the configuration file matches the setting of the base address switch block on the board. Make sure that no other system resource is using any of the eight memory locations starting at the specified base address. Reconfigure the base address, if necessary. Refer to Setting the Base Address on page 3-8 for instructions. |
| | Interrupt level is unacceptable. | Make sure that the interrupt level specified in the configuration file matches the setting of jumper J1 on the board. Make sure that no other system resource is using the specified interrupt level. Reconfigure the interrupt level, if necessary. Refer to Setting the Interrupt Level on page 3-13 for instructions. |
| | The board configuration is unacceptable. | Check the settings in the configuration file. Make sure that they match the settings of the switches and jumper on the board, where appropriate. |
| | The board is incorrectly aligned in the accessory slot. | Check installation. |
| | The board is damaged. | Contact the Keithley Data Acquisition Applications Engineering Department; refer to Technical Support on page 6-5. |
| Intermittent operation | Vibrations or loose connections exist. | Cushion source of vibration and tighten connections. |
| | The board is overheating. | Check environmental and ambient temperature. |
| | Electrical noise exists. | Provide better shielding or reroute wiring. |

Table 6-1. Troubleshooting Information (cont.)

| Symptom | Possible Cause | Possible Solution |
|--|--|---|
| Analog input conversion data appears to be invalid | An open connection exists. | Check wiring to screw terminal. |
| | An error exists in the configuration file. | Check configuration file for correct entries. |
| | Electrical noise exists. | Use a shielded cable for low-level applications. |
| | Differential input is out of range. | If you are using differential inputs, make sure that a bias current return path is provided; refer to Connecting an Analog Input Signal to a Differential Input on page 4-11 for more information. Make sure that excessive common-mode voltages are not present. |
| | Another system resource is using one of the eight memory locations starting at the specified base address. | Reconfigure the base address of the DAS-8 Series board; refer to Setting the Base Address on page 3-8 for more information. Check the I/O assignments of other system resources and reconfigure, if necessary. |
| System lockup | A timing error occurred. | Press [Ctrl] + [Break]. |

Technical Support

Before Returning any equipment for repair, call Keithley for technical support at:

1-888-KEITHLEY

Monday - Friday, 8:00 a.m. - 5:00 p.m., Eastern Time

An applications engineer will help you diagnose and resolve your problem over the telephone. Please make sure that you have the following information available before you call:

| | | |
|---------------------------|-------------------------------------|-------|
| DAS-8 board configuration | Model | _____ |
| | Serial Number | _____ |
| | Revision Code | _____ |
| | Base address setting | _____ |
| | Interrupt level setting | _____ |
| | Number of channels | _____ |
| | Input (S.E. or Diff.) | _____ |
| | Mode (uni. or bip.) | _____ |
| | 8254 C/T2 usage (Cascade or Normal) | _____ |
| | Number of EXP. brds. | _____ |
| Computer | Manufacturer | _____ |
| | CPU type | _____ |
| | Clock speed (MHz) | _____ |
| | KB of RAM | _____ |
| | Video system | _____ |
| | BIOS type | _____ |
| Operating system | Windows version | _____ |
| | Windows mode | _____ |
| Software package | Name | _____ |
| | Serial Number | _____ |
| | Version | _____ |
| | Invoice/Order Number | _____ |
| Compiler (if applicable) | Language | _____ |
| | Manufacturer | _____ |
| | Version | _____ |

| | | |
|-------------|------|-------|
| Accessories | Type | _____ |
| | Type | _____ |
| | Type | _____ |
| | Type | _____ |
| | Type | _____ |
| | Type | _____ |
| | Type | _____ |
| | Type | _____ |
| | Type | _____ |

If a telephone resolution is not possible, the applications engineer will issue you a Return Material Authorization (RMA) number and ask you to return the equipment. Include the RMA number with any documentation regarding the equipment.

When returning equipment for repair, include the following information:

- Your name, address, and telephone number.
- The invoice or order number and date of equipment purchase.
- A description of the problem or its symptoms.
- The RMA number on the **outside of the package**.

Repackage the equipment, using the original anti-static wrapping, if possible, and handle it with ground protection. Ship the equipment to:

ATTN.: RMA# _____
 Repair Department
 Keithley Instruments, Inc.
 28775 Aurora Road
 Cleveland, Ohio 44139
 Telephone 1-888-KEITHLEY
 FAX (440) 248-6168

Note: If you are submitting your equipment for repair under warranty, you must include the invoice number and date of purchase.

To enable Keithley to respond as quickly as possible, you must include the RMA number on the outside of the package.

A

Specifications

DAS-8 Specifications

Power Consumption

| | |
|-------------|-------------------------|
| +5V supply | 107mA typ. / 180mA max. |
| +12V supply | 6mA typ. / 10mA max. |
| -12V supply | 10mA typ. / 16mA max. |

Analog Inputs

| | |
|--------------------|--|
| Number of Channels | 8, Single-ended |
| Resolution | 12 bits (2.4mV/bit) |
| Accuracy | 0.01% of reading \pm bit |
| Full scale | \pm 5 Volt |
| Coding | Offset binary |
| Overvoltage | Continuous single channel to \pm 35V |
| Input current | 100nA max. at 25°C |
| Gain Tempco | Gain or F.S., \pm 25ppm/°C max. |

A/D Specification

| | |
|--------------|---|
| Type | Successive approximation |
| Resolution | 12 bit |
| Conversion | 12 μ s typ. (35 μ s max.) |
| Monotonicity | Guaranteed over operating temperature range |
| Linearity | \pm 1 bit |
| Zero drift | 10ppm/°C max. |
| Gain drift | 50ppm/°C max. (30ppm/°C, opt.) |

Sample Hold Amplifier

| | |
|------------------|---|
| Acquisition time | 15ms to 0.01%, typ. for full-scale step input |
| Dynamic | 1 bit (2.44mV) @ 2000V/sec sampling error |

Reference Voltage Output

| | |
|--------------|--|
| Reference | +10.0V ($\pm 0.1V$) |
| Tempco | 50ppm/ $^{\circ}C$ max., 30ppm/ $^{\circ}C$ (optional) |
| Load current | $\pm 2mA$ max. |

Digital I/O

| | |
|------------------------------|---------------------------------------|
| OP1–4 output low voltage | 0.5V max. @ 8.0mA (current sink) |
| OP1–4 output high voltage | 2.7V min. @ $-0.4mA$ (current source) |
| IP1–3 input low voltage | 0.8V max. |
| IP1–3 input low current | -0.4 max. |
| IP1–3 input high voltage | 2.0V min. |
| IP1–3 input high current | 20 μA max. @ 2.7V |

Interrupt Inputs

| | |
|--------|----------------------------------|
| Type | Positive (rising) edge triggered |
| Level | 2–7 jumper selectable |
| Enable | Via INT of CONTROL Register |

Interrupts are latched in an internal flip-flop on the DAS-8. The state of this flip-flop corresponds to the INT bit (STATUS Register). It is cleared by a write to the CONTROL Register. Service routines should acknowledge and re-enable interrupt flop.

Counter/Timer

| | |
|-------------------------|---|
| Type | 8254 programmable interval timer |
| Counters | 3 down-counters (16-bit) |
| Driver capability | 2.2mA @ 0.45Vdc (5 LSTTL loads) |
| Input, Gate, Clock load | TTL/DTL/CMOS compatible ($\pm 10\mu\text{A}$) |
| Input Clock Frequency | Not less than 10MHz max. |
| Active count edge | Negative (falling) |
| Clock pulse width | 50ns high/50ns low (min.) |

Power Outputs

| | |
|---------------------|---|
| IBM/PC Bus Supplies | +5Vdc and $\pm 12\text{Vdc}$ |
| Tolerance | +5Vdc and +12Vdc ($\pm 5\%$) -12Vdc ($\pm 10\%$) |
| Loading | Dependent upon peripheral |

General Environmental

| | |
|-----------------|---------------------------|
| Operating Temp. | 0° to 50°C |
| Storage Temp. | -20° to 7°C |
| Humidity | 0 to 90% (non-condensing) |
| Weight | 4 oz. (120 g) |

DAS-8/PGA Specifications

DAS-8/PGA specifications are similar to those quoted for the DAS-8 with the following exceptions:

Power Consumption

| | |
|-------------|-----------------------|
| +5V supply | 800mA typ. / 1A max. |
| +12V supply | 2mA typ. / 5mA max. |
| -12V supply | 18mA typ. / 30mA max. |

Analog Inputs

| | |
|--------------------|--|
| Number of channels | 8, Single-ended/Differential (switch selectable) |
| Resolution | 12 bit |
| Accuracy | 0.01% of reading \pm bit |
| Full Scale Range | 9 different gains of: |

Table A-1. DAS-8/PGA Gains

| PGA | | PGA-G2 | |
|-----------------------|------------|-----------------------|------------|
| ± 5 Vdc (default) | | ± 5 Vdc (default) | |
| ± 10 | 0 to 10Vdc | ± 10 | 0 to 10Vdc |
| ± 0.5 | 0 to 1 | ± 2.5 | 0 to 5 |
| ± 0.05 | 0 to 0.1 | ± 1.25 | 0 to 2.5 |
| ± 0.01 | 0 to 0.02 | ± 0.625 | 0 to 1.25 |

| | |
|-------------|---|
| Coding | Offset binary (Bipolar) True binary (Unipolar) |
| Gain Tempco | \pm ppm/ $^{\circ}$ C max. |
| Zero Drift | ± 10 ppm/ $^{\circ}$ C max. |

Sample Hold Amplifier

| | |
|------------------|--|
| Acquisition time | 4 μ s to 0.1%, typical for full-scale step input |
|------------------|--|

DAS-8/AO Specifications

Analog Input

Channels 8 Differential
 Resolution 12 bits
 Absolute Accuracy 0.05% of full scale
 Input Ranges:

Table A-2. DAS-8/AO Input Ranges

| Bipolar | Unipolar | Throughput | CMMR |
|---------|------------|------------|-------|
| ±10V | 0 to 10V | 15.4kHz | 70dB |
| ±5V | -- | | |
| ±0.5V | 0 to 1V | | |
| ±50mV | 0 to 100mV | | |
| ±10mV | 0 to 20mV | 8.3kHz | 100dB |

Input Common Mode 6.5V
 Input impedance >100MΩ in parallel with 100pF
 Leakage current 250nA max.
 Linearity ±1 bit
 Gain drift 35ppm of FSR/°C
 Zero drift 20ppm of FSR/°C
 Noise 30μV P-P typical
 Acquisition time Gain = 1 30μs
 Gain = 500 95μs
 Conversion time 35μs

Analog Output

| | |
|----------------------------|---|
| Channels | 2 |
| Resolution | 12 bits |
| Ranges | 0–5V, 0–10V, $\pm 2.5V$, $\pm 5V$, $\pm 10V$ |
| Settling time | 4 μ s to 0.01% for full-scale step |
| Input data decoding | Unipolar - true binary (right justified) Bipolar - Offset binary (right justified) |
| Output current | 5mA |
| Output resistance | <0.1Ohm |
| Capacitive Drive | |
| Capability | xxx |
| Integral non-linearity | 1/2 LSB |
| Differential non-linearity | 3/4 LSB |
| Gain error | Adjustable to zero |
| Offset drift | Bipolar = 4ppm/ $^{\circ}C$ Unipolar = 10ppm/ $^{\circ}C$ |
| Gain drift | 30ppm of FSR/ $^{\circ}C$ |

4–20 mA Current Loop

| | |
|------------------------|--|
| Type | 4–20mA constant-current sink to ground |
| Output resistance | >100MOhm |
| Min. loop excitation V | +6V |
| Max. loop excitation V | +36V |

Digital I/O Outputs (Standard LSTTL)

| | |
|--------------|--------------------------------------|
| Output ports | 4 bits |
| Low voltage | 0.5V max. at sink current = 8.0mA |
| High voltage | 2.4V min. at source current = –0.4mA |

Inputs (IP 1–3 and Interrupts) (LSTTL)

| | |
|--------------|-----------------|
| Low voltage | 0.8V max. |
| Low current | –0.4V max. |
| High voltage | 2.0V min. |
| High current | 20 μ A max. |

Interrupt Channel

| | |
|--------|-----------------------------|
| Level | 2–7 Software selectable |
| Enable | Via INT of Control Register |

Note: On the DAS-8/AO, Interrupts latch in an internal flip-flop whose state corresponds to the INT bit in the Status Register. A write to the Status Register clears this flip-flop. Service routines should acknowledge and re-enable the interrupt flip-flop.

Programmable Timer

| | |
|-----------------|-----------------------------------|
| Type | 82C54 programmable interval timer |
| Counters | 3-down counter, 16 bit |
| Output drive | 2.2mA at 0.45V (5 LSTTL loads) |
| Input gate | TTL/DTL/CMOS compatible |
| Clock frequency | 1MHz |
| Active edge | Negative (falling) |

Power Supplies

| | |
|------|--------------------------|
| +5V | 800mA typ. / 1100mA max. |
| +12V | 10mA max. |

DAS-8/LT Specifications

Power Consumption

| | |
|-------------|-------------------------|
| +5V supply | 6mA typ. / 30mA max. |
| +12V supply | 15mA typ / 22mA max. |
| Total | 205mW typ. / 414mW max. |

Analog Inputs

| | |
|--------------------|--|
| Number of Channels | 8, Single-ended |
| Resolution | 12 bits (2.4mV/bit) |
| Accuracy | 0.01% of reading \pm bit |
| Full scale | \pm 5V |
| Coding | Offset binary |
| Overvoltage | Continuous single channel to \pm 35V |
| Input current | 400pA max. at 25°C |
| Gain Tempco | Gain or F.S., \pm 25 ppm/°C max. Zero, \pm 15 μ V/°C max. |
| Settling time | 4.5 μ s to 0.01%, typ. for F.S. step input of 10V |

A/D Specification

| | |
|--------------|---|
| Type | Successive approximation |
| Resolution | 12 bit |
| Conversion | 12 μ s typ., (35 μ s max.) |
| Monotonicity | Guaranteed over operating temperature range |
| Linearity | \pm 1 bit |
| Zero drift | 10ppm/°C max. |
| Gain drift | 50ppm/°C max. |

Reference Voltage Output

| | |
|--------------|--------------------------------------|
| Reference | +10.0V (\pm 0.1V) |
| Tempco | 50ppm/°C (max.), 30ppm/°C (optional) |
| Load current | \pm 2mA max. |

Digital I/O (Type 74HCT273)

| | |
|------------------------------|-------------------------------------|
| OP1–4 output low voltage | 0.33V max. @ 4.0mA (current sink) |
| OP1–4 output high voltage | 3.8V min. @ –0.4mA (current source) |
| IP1–3 input low voltage | 0.8V max. |
| IP1–3 input low current | –0.4 max. |
| IP1–3 input high voltage | 2.0V max. |
| IP1–3 input high current | 1.0 μ A max. @ 20.0 or 5.0V |

Interrupt Inputs

| | |
|--------|----------------------------------|
| Type | Positive (rising) edge triggered |
| Level | 2–7 jumper selectable |
| Enable | Via INT of CONTROL Register |

Note: Interrupts are latched in an internal flip-flop on the DAS-8. The state of this flip-flop corresponds to the INT bit (STATUS Register). It is cleared by a write to the CONTROL Register. Service routines should acknowledge and re-enable interrupt flop.

Power-On Initialization State

Channel 0 selected
Outputs OP1–4 low

Counter/Timer

| | |
|-------------------------|---|
| Type | 82C54 programmable interval timer |
| Counters | 3 down counters (16 bit) |
| Driver capability | 2.2mA @ 0.45Vdc (5 LSTTL loads) |
| Input, Gate, Clock load | TTL/DTL/CMOS compatible ($\pm 10\mu\text{A}$) |
| Input clock frequency | 10MHz Max. |
| Active count edge | Negative (falling) |
| Clock pulse width | 50ns high/50ns low (min.) |

Internal Oscillator

| | |
|-----------|-----------|
| Frequency | 1.000MHz |
| Symmetry | 40 to 60% |

Power Outputs

| | |
|---------------------|--------------------------------------|
| IPM/PC Bus supplies | +5Vdc +12Vdc -12Vdc @ 5mA max. |
| Loading | Dependent upon peripheral |

General Environmental

| | |
|-----------------------|---------------------------|
| Operating temperature | 0° to 50°C |
| Storage temperature | -20° to 70°C |
| Humidity | 0 to 90% (non-condensing) |
| Weight | 4 oz. (120 g) |

B

Connector Pin Assignments

Figure B-1 shows the main I/O connector and its pin assignments on a DAS-8 or DAS-8/LT board; Table B-1 contains a more detailed description of the pins. Figure B-2 shows the main I/O connector and its pin assignments on a DAS-8/PGA(G2) board; Table B-2 contains a more detailed description of the pins. Figure B-3 shows the main I/O connector and its pin assignments on a DAS-8/AO board; Table B-3 contains a more detailed description of the pins.

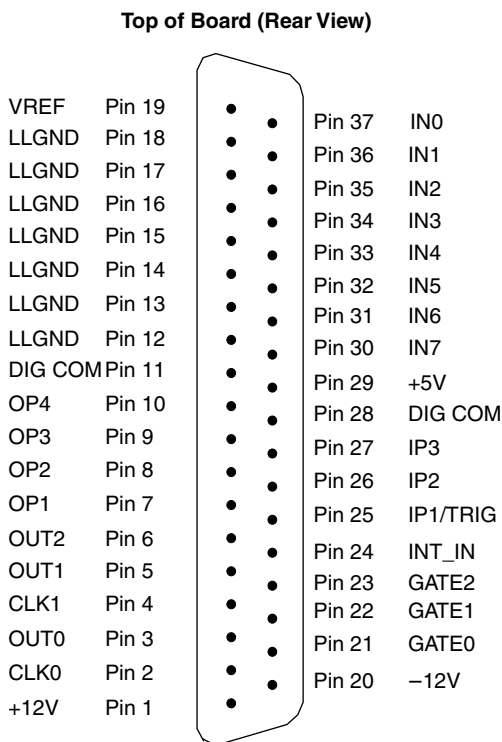

Figure B-1. Main I/O Connector (DAS-8/LT)

**Table B-1. Main I/O Connector Pin Assignments
for the DAS-8/LT**

| Pin | Name | Function |
|------------|-------------|--|
| 1 | +12V | +12V power from host computer |
| 2 | CLK0 | 82C54 C/T0 clock input |
| 3 | OUT0 | 82C54 C/T0 output |
| 4 | CLK1 | 82C54 C/T1 clock input |
| 5 | OUT1 | 82C54 C/T1 output |
| 6 | OUT2 | 82C54 C/T2 output |
| 7 | OP1 | Digital output bit 0 |
| 8 | OP2 | Digital output bit 1 |
| 9 | OP3 | Digital output bit 2 |
| 10 | OP4 | Digital output bit 3 |
| 11 | DIG COM | Digital common. Return for all logic signals and power supply currents. Connected to computer frame. |
| 12 | LL GND | Low-level grounds. These are common returns and shields for the analog input channels. |
| 13 | LL GND | |
| 14 | LL GND | |
| 15 | LL GND | |
| 16 | LL GND | |
| 17 | LL GND | |
| 18 | LL GND | |
| 19 | VREF | 10V ($\pm 0.1V$) reference output |
| 20 | -12V | -12V power from host computer |
| 21 | GATE0 | 82C54 C/T0 gate input |
| 22 | GATE1 | 82C54 C/T1 gate input |
| 23 | GATE2 | 82C54 C/T2 gate input |
| 24 | INT_IN | External interrupt input / external clock source input |
| 25 | IP1 | Digital input bit 0 / Digital trigger input |
| 26 | IP2 | Digital input bit 1 |
| 27 | IP3 | Digital input bit 2 |
| 28 | DIG COM | Digital common |
| 29 | +5V | +5V power from host computer |
| 30 | IN7 | Analog input channel 7 |

Table B-1. Main I/O Connector Pin Assignments for the DAS-8/LT (cont.)

| Pin | Name | Function |
|-----|------|------------------------|
| 31 | IN6 | Analog input channel 6 |
| 32 | IN5 | Analog input channel 5 |
| 33 | IN4 | Analog input channel 4 |
| 34 | IN3 | Analog input channel 3 |
| 35 | IN2 | Analog input channel 2 |
| 36 | IN1 | Analog input channel 1 |
| 37 | IN0 | Analog input channel 0 |

Top of Board (Rear View)

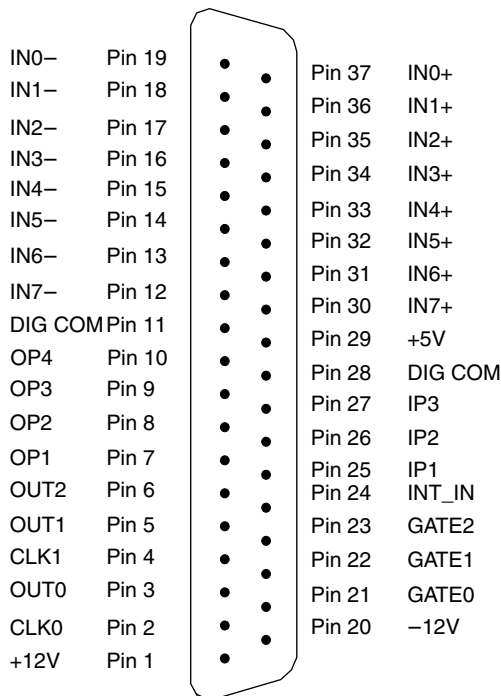

Figure B-2. Main I/O Connector [DAS-8/PGA(G2)]

**Table B-2. Main I/O Connector Pin Assignments
for the DAS-8/PGA(G2)**

| Pin | Name | Function |
|------------|-------------|--|
| 1 | +12V | +12V power from host computer |
| 2 | CLK0 | 82C54 C/T0 clock input |
| 3 | OUT0 | 82C54 C/T0 output |
| 4 | CLK1 | 82C54 C/T1 clock input |
| 5 | OUT1 | 82C54 C/T1 output / conversion clock output |
| 6 | OUT2 | 82C54 C/T2 output |
| 7 | OP1 | Digital output bit 0 |
| 8 | OP2 | Digital output bit 1 |
| 9 | OP3 | Digital output bit 2 |
| 10 | OP4 | Digital output bit 3 |
| 11 | DIG COM | Digital common |
| 12 | IN7- | Analog input channel 7 (-) |
| 13 | IN6- | Analog input channel 6 (-) |
| 14 | IN5- | Analog input channel 5 (-) |
| 15 | IN4- | Analog input channel 4 (-) |
| 16 | IN3- | Analog input channel 3 (-) |
| 17 | IN2- | Analog input channel 2 (-) |
| 18 | IN1- | Analog input channel 1 (-) |
| 19 | IN0- | Analog input channel 0 (-) |
| 20 | -12V | -12V power from host computer |
| 21 | GATE0 | 82C54 C/T0 gate input |
| 22 | GATE1 | 82C54 C/T1 gate input |
| 23 | GATE2 | 82C54 C/T2 gate input |
| 24 | INT_IN | External interrupt input / external clock source input |
| 25 | IP1 | Digital input bit 0 / Digital trigger input |
| 26 | IP2 | Digital input bit 1 |
| 27 | IP3 | Digital input bit 2 |
| 28 | DIG COM | Digital common |
| 29 | +5V | +5V power from host computer |
| 30 | IN7+ | Analog input channel 7 (+) |

**Table B-2. Main I/O Connector Pin Assignments
for the DAS-8/PGA(G2) (cont.)**

| Pin | Name | Function |
|-----|------|----------------------------|
| 31 | IN6+ | Analog input channel 6 (+) |
| 32 | IN5+ | Analog input channel 5 (+) |
| 33 | IN4+ | Analog input channel 4 (+) |
| 34 | IN3+ | Analog input channel 3 (+) |
| 35 | IN2+ | Analog input channel 2 (+) |
| 36 | IN1+ | Analog input channel 1 (+) |
| 37 | IN0+ | Analog input channel 0 (+) |

Top of Board (Rear View)

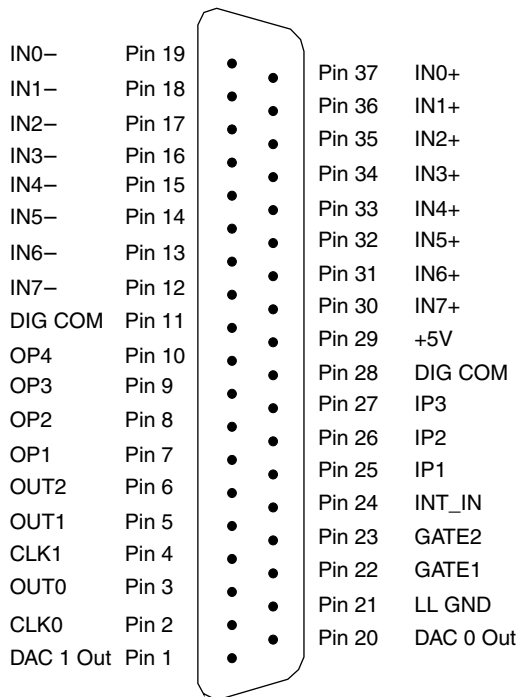

Figure B-3. Main I/O Connector (DAS-8/AO)

**Table B-3. Main I/O Connector Pin Assignments
for the DAS-8/AO**

| Pin | Name | Function |
|------------|-------------|--|
| 1 | DAC 1 Out | D/A Converter #1 Output |
| 2 | CLK0 | 82C54 C/T0 clock input |
| 3 | OUT0 | 82C54 C/T0 output |
| 4 | CLK1 | 82C54 C/T1 clock input |
| 5 | OUT1 | 82C54 C/T1 output / conversion clock output |
| 6 | OUT2 | 82C54 C/T2 output |
| 7 | OP1 | Digital output bit 0 |
| 8 | OP2 | Digital output bit 1 |
| 9 | OP3 | Digital output bit 2 |
| 10 | OP4 | Digital output bit 3 |
| 11 | DIG COM | Digital common |
| 12 | IN7- | Analog input channel 7 (-) |
| 13 | IN6- | Analog input channel 6 (-) |
| 14 | IN5- | Analog input channel 5 (-) |
| 15 | IN4- | Analog input channel 4 (-) |
| 16 | IN3- | Analog input channel 3 (-) |
| 17 | IN2- | Analog input channel 2 (-) |
| 18 | IN1- | Analog input channel 1 (-) |
| 19 | IN0- | Analog input channel 0 (-) |
| 20 | DAC 0 Out | D/A Converter #0 Output |
| 21 | LL GND | Low Level Ground |
| 22 | GATE1 | 82C54 C/T1 gate input |
| 23 | GATE2 | 82C54 C/T2 gate input |
| 24 | INT_IN | External interrupt input / external clock source input |
| 25 | IP1 | Digital input bit 0 / Digital trigger input |
| 26 | IP2 | Digital input bit 1 |
| 27 | IP3 | Digital input bit 2 |
| 28 | DIG COM | Digital common |
| 29 | +5V | +5V power from host computer |
| 30 | IN7+ | Analog input channel 7 (+) |

**Table B-3. Main I/O Connector Pin Assignments
for the DAS-8/AO (cont.)**

| Pin | Name | Function |
|------------|-------------|----------------------------|
| 31 | IN6+ | Analog input channel 6 (+) |
| 32 | IN5+ | Analog input channel 5 (+) |
| 33 | IN4+ | Analog input channel 4 (+) |
| 34 | IN3+ | Analog input channel 3 (+) |
| 35 | IN2+ | Analog input channel 2 (+) |
| 36 | IN1+ | Analog input channel 1 (+) |
| 37 | IN0+ | Analog input channel 0 (+) |

DriverLINX Implementation Notes

Applications construct DriverLINX data-acquisition tasks by combining a small number of DriverLINX operations and events in many possible ways. The following table summarizes the operations and events that DriverLINX supports for the DAS-8 Series boards.

The following sections describe how the hardware features of the DAS-8 Series correspond to the DriverLINX API. The following table summarizes allowed data-acquisition modes supported by each subsystem of DriverLINX.

Table C-1. DriverLINX Modes Supported by DAS-8 Series

| Subsystem | Polled | Interrupt | DMA | Other |
|----------------|--------|-----------|-----|-------|
| Analog Input | X | X | | X |
| Analog Output | X | X | | X |
| Digital Input | X | X | | X |
| Digital Output | X | X | | X |
| Counter/timer | X | | | |
| Device | | | | X |

The following table summarizes the operations and events implemented for each of the supported modes of DriverLINX subsystems using the DAS-8.

Note: All subsystems allow the MESSAGE operation for the DAS-8 Series boards.

Table C-2. Modes, Operations, and Events

| Subsystem | Mode | Operation | Events | | |
|-------------------|-----------|--------------------------|-----------|---------------|-------------------|
| | | | Timing | Start | Stop |
| Analog Input | Polled | Start | rate, dig | cmd, ana, dig | TC, ana, dig |
| | Interrupt | Start, Stop, Status | rate, dig | cmd, ana, dig | cmd, TC, ana, dig |
| | DMA | | | | |
| | Other | Initialize | | | |
| Analog Output | Polled | Start | rate, dig | cmd, dig | TC, dig |
| | Interrupt | Start, Stop, Status | rate, dig | cmd, dig | cmd, TC, dig |
| | Other | | | | |
| Digital Input | Polled | Start | null | null, cmd | null, TC |
| | Interrupt | | | | |
| | Other | Initialize | | | |
| Digital Output | Polled | Start | null | null, cmd | null, TC |
| | Interrupt | | | | |
| | Other | Initialize | | | |
| Counter/ timer | Polled | Start | rate | | |
| | Other | Initialize | | | |
| Device | Other | Initialize, Capabilities | | | |

The following list explains the Event abbreviations in the preceding table:

- **null** — Null or None Event when a Service Request doesn't require an event.
- **cmd** — Command Event when DriverLINX starts or stops a task on software comand.
- **TC** — Terminal Count Event when DriverLINX processes all data buffers once.
- **rate** — Rate Event specifies how DriverLINX paces or clocks data transfer.
- **dig** — Digital Event specifies a trigger, clock, or other control signal to pace, start, or stop a task.
- **ana** — Analog Event specifies an analog input signal or pace, start, or stop a task.

Logical Channels

DriverLINX uses logical channel numbers to specify physical analog, digital, and counter/timer channels on the DAS-8. Generally, the logical channel number is the same as the physical channel number; but, in some cases, additional logical channels are defined by DriverLINX to specify combinations of physical channels. For instance, Counter/Timer Logical Channel 4 refers to physical counter/timers 1 and 2 which have been chained together using an external jumper on the DAS-8's analog connector. Refer to the appropriate DriverLINX subsystem section in the DriverLINX documentation to see how logical channels are mapped onto the hardware.

Analog Input Subsystem

The DAS-8 contains one A/D converter and an 8-channel multiplexer. The A/D channels can be used in differential (channels 0-7, DAS-8PGA and DAS-8/AO) or single-ended (channels 0-7, all models) configuration. The inputs are labeled CH0 HI IN [37], CH0 LO IN [10], etc., and are located on the D-type male connector that projects through the rear panel of the computer.

Logical Channels

Analog Input Logical Channels 0-7 correspond to physical analog input channels 0-7.

Analog Input Initialization

Initialization of the analog input subsystem aborts any active interrupt data acquisition tasks and tests the counter/timer connections. The counter/timer connections test is used by DriverLINX to check the validity of later DriverLINX Service Requests and to select the internal commands for programming the counter/timers. For instance, if a Service Request specifies Logical Counter 3, but DriverLINX did not detect the required external connections during subsystem initialization, the Service Request will be rejected with an error. Similarly, if interrupt mode is requested, but DriverLINX did not detect previously a clock signal at the INTERRUPT INPUT [24] line, the request will fail.

Three tests are performed every time the analog input subsystem is initialized. First, DriverLINX determines if Logical Counter 3 is available by testing if physical counter 2 can clock physical counter 1, Second, the presence of Logical Counter 4 is detected by testing if physical counter 2 clocks physical counter 0. Third, DriverLINX determines if Logical Counters 2, 3, or 4 are connected to the INTERRUPT INPUT [24] line. The first counter that clocks this input stops the test. All these tests may fail to detect a valid connection if the gate inputs of any counter are held low during testing.

External Triggering

Applications may require that the start of a data-acquisition task be synchronous with the occurrence of an external signal. Data-acquisition devices commonly support this requirement by providing an input line for a TTL-level signal that will start, or trigger, the data-acquisition process on a specified state change of the signal line. Once data collection starts, further transitions on the external trigger are usually ignored.

The DAS-8 hardware does not support external triggering as defined above. However, you can obtain almost the same results using one of two techniques. A hardware trigger can be implemented by using the gate input of the appropriate clock counter. Holding the gate low will inhibit the clock from counting. An active high level will start the clock. Note that pulling the line low during the counting will suspend the counting operation again unlike the preceding definition of an external trigger. When using this technique, you do not need to modify the DriverLINX Service Request because DriverLINX cannot control or detect the gate inputs to the DAS-8 counters.

The second technique to implement an external trigger uses a Digital Start Event. The DriverLINX Service Request can specify that data-acquisition starts when one or more digital input lines change value. DriverLINX supports this technique only on the 4-bit digital input port (digital Logical Channel 0). External triggering using this technique requires software polling so that data hold time for a trigger must be at least 3ms on a 10MHz AT, to at least 20ms on a 4.77MHz XT.

External Clocking

Some applications require that the timing, or pacing, of data-acquisition sampling be synchronized to an external clock signal. To do this with the DAS-8, you must connect the external clock to the INTERRUPT INPUT [24] input on the external analog D-connector on the board's mounting bracket. To inform DriverLINX that external clocking is requested, use either a Rate Timing Event on Logical Channel 6 with external clock input or a Digital Timing Event that specifies "Ext Clock" as the digital mask, zero as the pattern, and "not equals" as the test. External clocking can be used in either polled or interrupt modes.

Data Coding

The A/D uses offset binary coding for bipolar inputs and straight binary for unipolar inputs. For all ranges and configurations the minimum value reported is 0 and the maximum value is 4095.

A/D data can be returned in native or integer formats. The native format of the DAS-8 returns the 12A/D bits left shifted by four bits and the low-order four bits are zero. The integer format returns the data as a two's-complement number with a range of 2048 to 2047 in bipolar mode and 0 to 4095 in unipolar mode. Integer format is only supported for polled and interrupt modes, while native format is supported by all modes.

For example, for a gain of 1 in the $\pm 10\text{V}$ range (bipolar configuration) the voltage resolution would be $\frac{20\text{V}}{4096} = 4.88$.

Table C-3.

| Input Voltage | A/D Binary Value |
|----------------------|-------------------------|
| -10V | 0 |
| 0V | 2048 |
| +4.88mV | 2049 |
| +10V | 4095 |

For a gain of 1 in the 0 to +10V range (unipolar configuration) the voltage resolution would be $\frac{10V}{4096} = 2.44mV$.

Table C-4.

| Input Voltage | A/D Binary Value |
|---------------|------------------|
| 0V | 0 |
| +5V | 2048 |
| +5.002V | 2049 |
| +10V | 4095 |

The values returned by the A/D converter always range from 0 to 4095 independent of the gain or channel configuration. For example, for a gain of 100 (bipolar configuration) the voltage resolution would be

$$\frac{20V}{4096 \times 100} = 48.8\mu V$$

Table C-5.

| Input Voltage | A/D Binary Value |
|---------------|------------------|
| -100V | 0 |
| 0V | 2048 |
| 48.8 μ V | 2049 |
| +100mV | 4095 |

A/D Conversion Delay

The maximum A/D conversion delay depends on which logical counter is specified and the frequency of the timing clock. For Logical Counter 2, the longest delay between samples is 65,535 times the clock frequency. For Logical counters 3 and 4, the longest delay is 4,294,967,295 times the clock frequency with a 1MHz clock, Logical Counter 2 can delay 65.5mS while Logical Counters 3 and 4 can delay 1 hour, 11 minutes, and 35 seconds.

The minimum conversion delay for Logical Counters 0, 1, and 2 is two clock tics and for Logical Counters 3 and 4 is four clock tics. However, the minimum usable conversion delay depends on the data acquisition mode, the speed of the computer, and the gain and A/D conversion speed of the data acquisition board. The maximum sustainable data acquisition rate decreases with gain on boards with programmable gain. You should perform empirical tests with your specific hardware setup to determine the minimum practical conversion delay.

A/D Data Lost

The DAS-8 does not provide hardware monitoring of A/D data overruns. You must determine empirically that the required conversion delay is supported by your system. The easiest way to check is by inserting a known periodic signal into an A/D channel and picking the smallest conversion delay required. Use the time measurement cursors on the Digital Storage Oscilloscope in the LearnDriverLINX facility in the DriverLINX program to measure the period of the recorded waveform. If the selected conversion delay is too small, the measured period of the input signal will decrease. If this happens, increase the conversion delay until the measured period matches the input period.

Analog Output Subsystem

The DAS-8/AO boards contain two channels of multiplying 12-bit D/A converters. The outputs are labeled DAC 9 OUT [20] and DAC 1 OUT [1] and are located on the D-type male connector that projects through the rear panel of the computer.

Analog Output Initialization

Initialization of the Analog Output subsystem loads a value into both D/A channels to force the output voltage to zero.

External Triggering

See the External Triggering section under the Analog Input Subsystem.

External Clocking

See the External Clocking section under the Analog Input Subsystem.

Data Coding

The D/A channels use straight binary coding. The minimum value that can be used is 0 and the maximum value is 4095. Analog output values are determined by the Analog Output Range switches (S3 and S4). For example, if you use the 0-5V range, the D/A output range will be as follows:

$$\text{Voltage Resolution} = \frac{-V_{\text{ref}} = -5\text{V}}{4096} = 1.22\text{mV}.$$

Table C-6.

| Binary Value | D/A Output Voltage |
|---------------------|---------------------------|
| 0 | 0 |
| 2048 | 2.5V |
| 4095 | 5.0V |

If you output larger or smaller values, the high-order bits will be ignored. So, 4096 would give an output voltage of 0V, and -1 would give an output voltage of 5.0V.

D/A Conversion Delay

D/A conversions are timed using either software polling of the counter/timer or interrupts from INT IN [24] signal. Either technique requires software to update the hardware registers with new values as rapidly as possible after a clock event is recognized. The DAS-8 models cannot support direct hardware timing of D/A output.

The minimum D/A conversion delay is two clock ticks. However, the practical minimum conversion delay is much higher and depends on the type and the speed of your machine. Variations in interrupt latencies and bus timing will add noticeable jitter to D/A signals output at high rates. This is also strongly influenced by the CPU's operating mode—real versus protected mode. Consult the DriverLINX Appendix on *Interrupt Latencies* for more information and run empirical tests to determine suitability of D/A output for the intended purpose.

The D/A conversion delay to output a periodic waveform with a given number of samples per period can be determined simply. For instance, the conversion delay for a 200Hz wave with 100 samples/cycle is

$$V = \frac{1}{\text{frequency}} = \frac{1}{200\text{Hz}} = 5\text{ms}$$
$$\text{D/A conversion delay} = \frac{5\text{ms}}{100 \text{ samples}} = 50\text{ms}$$

D/A Data Lost

There is no way for the DAS-8 hardware to monitor D/A overruns. You must empirically insure that the required conversion delay can be supported. One way to check is using the D/A waveform generator to output a periodic waveform. Select the desired delay and then measure the frequency output either with an oscilloscope or a frequency counter. If the D/A conversion delay you chose was too small, the output frequency will vary from the selected frequency. Try larger delays until the frequencies match.

Digital Input and Output Subsystems

Logical Channels

The DAS-8 has a custom 3-bit digital input port and a 4-bit digital output port (Logical Channel 0). The custom input channel is configured as IP1, IP2, IP3, and the output channel as OP0, OP1, OP2, OP3.

DriverLINX implements all digital I/O on the DAS-8 as immediate, single-value transfers on execution of the DriverLINX Service Request. All digital I/O is right-justified. Unused bits are ignored on output and are returned as zero on input.

Digital Input Initialization

Initialization of the DriverLINX Digital Input subsystem does not change Logical Channel 0.

Digital Output Initialization

Initialization of the DriverLINX Digital Output subsystem resets the value of all output ports to zero.

Digital I/O Conversion Delay

Digital I/O is not clocked.

Digital I/O Data Lost

Digital I/O data overruns are not detected by the DAS-8 hardware.

Counter/Timer Subsystem

The DAS-8 uses an Intel 8254 Programmable Interval Timer which consists of 3 internal 16-bit counters, Counter 0, Counter 1, and Counter 2. The clock, gate, and output connections of Counters 0 and 1 are undedicated and available on the DAS-8 external connector. Counter 2's gate and output connections are externally available also, but the clock input is internally connected to either the PC bus clock or a 1MHz crystal oscillator.

Logical Channels

The Logical Channels for the DriverLINX counter/timer subsystem correspond to the following physical channels:

Table C-7. Corresponding Logical and Physical Channels

| Logical Channel | Physical Channel |
|------------------------|--|
| 0 | Counter/timer 0 |
| 1 | Counter/timer 1 |
| 2 | Counter/timer 2 |
| 3 | Counter/timers 2 and 1 (Connect CTR 2 OUT [6] to CTR 1 IN [4]) |
| 4 | Counter/timers 2 and 0 (Connect CTR 2 OUT [6] to CTR 0 IN [2]) |
| 5 | Counter/timers 0 and 1 (Connect CTR 0 OUT [3] to CTR 1 IN [4]) |
| 6 | Pseudo-channel for external clock input at INTERRUPT IN [24] |

DriverLINX uses physical Counter 2 whenever the application requests an internal clock for a data-acquisition task. The timing interval generated by Counter 2 can vary from 2 to 65,535 clock tics. If a longer timing interval is needed for an application, Logical Channels 3 or 4 can be specified. Be sure to externally connect the appropriate lines as indicated in the table. The availability of Logical Channels 3 and 4 is tested whenever the analog input subsystem is initialized.

Counter/Timer Initialization

Power-up state of the counters is undefined. Initialization establishes the state of each counter as a binary rate generator with a down count of 65535.

Counter/Timer Interrupt

Counter/timer interrupts are not supported by the DAS-8.

Event Counting

Event counting is the simplest counter/timer function. Only one counter is required and the external events to be counted are used as an external clock input signal to the counter. The application program reads the accumulated count as it deems appropriate.

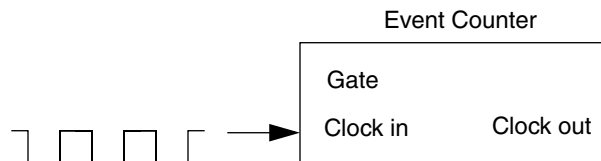

As the DAS-8 allows an external clock input only for Counters 0 and 1, DriverLINX supports event counting only for Logical Counters 0 and 1. The events to be counted are connected to CTR0 IN [2] or CTR 1 IN [4]. Events are active low TTL-clock pulses, where a clock pulse is defined as a falling edge followed by a rising edge. Gate 0 [21] or Gate 1 [22] must be left open or held high. The maximum number of events that may be counted before the counter rolls over is 65535. Counter rollover is detected and reported.

Frequency Measurement

Without external hardware, support of frequency measurement using the DAS-8 hardware configuration is limited. Frequency measurement requires an external connection between two counters.

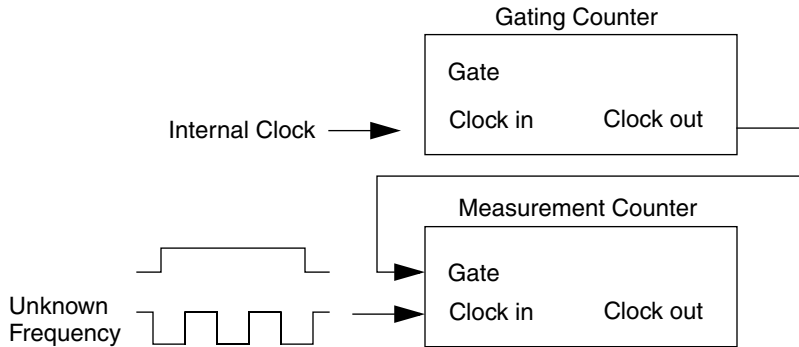

Frequency measurement requires two counter/timers used as measurement and gating counters. The unknown frequency is input as the clock source to the measurement counter. The gate input of the measurement counter is then activated for a known interval as timed by the gating counter. The gating counter is clocked from a known internal crystal reference clock. The unknown input frequency is then calculated as

$$\text{frequency} = \frac{\text{measured count}}{\text{gate time}}$$

The accuracy of the measurement is a function of the unknown input frequency and the gate time. As the input frequency decreases, the gate time must increase to preserve accuracy. It is the responsibility of the application program to choose the gate time. To measure a 0.1Hz signal, the gate time should be approximately three minutes.

In DriverLINX for the DAS-9 models, Logical Counter 0 is the measurement counter and Logical counter 3 is the gating counter. The output of Logical Counter 3 (CTR 1 OUT [5]) must be externally connected to the gate input of logical counter 0 (GATE 0 [21]). The unknown frequency to be measured is fed to the clock input of Logical Counter 0 {CTR 0 IN [2], active low) and DIG COM [11].

Remember the signal must be TTL (0 to 5 volts). Do not exceed this voltage range as damage to the counter could result. Also, Logical Counter 3 must be configured with an external jumper as indicated in the preceding table. Note that, unlike the technique used by your computer board's DOS driver, connecting the gating signal generated by Logical Counter 3 to a digital input line is not required.

Clock pulses are defined as a falling edge followed by a rising edge. This is a function of the Intel 8254 hardware and cannot be changed without external hardware.

The duration of the gating interval has a small jitter as the gate activates before the software can load the time duration into the counter. Therefore, the relative accuracy of the measurement will be less with shorter measurement intervals and higher input frequencies than would be anticipated from hardware considerations alone.

In polled mode, DriverLINX does not return control to the calling application until the frequency measurement is completed. The measured frequency in clock tics counted during the gating period is returned in the Result field of the DriverLINX Service Request. Overflow of the measurement counter is detected if the gating interval is too long. Frequency measurement in Interrupt mode is not supported by the DAS-8.

Also see the *Burr-Brown Data Acquisition Handbook* for simple external circuits using an Intel 8254 for performing frequency measurements.

Pulse Output

The DAS-8 counter/timers can be used to generate TTL pulse trains. Due to the design of the DAS-8, the Logical Counters have different capabilities.

Square waves must specify the output *period* and variable duty cycle waves must specify the output *period* and the *onCount*.

Logical Counter 2 can only generate square waves using the internal clock. The output frequency is determined by the *period* field of the Rate Event and the *onCount* field is returned as $\frac{\text{period} + 1}{2}$.

Logical Counters 3 and 4 can generate square and variable duty cycle waves using the internal clock. However, arbitrary duty cycles are not possible. The *onCount* must be 3 off count ($=period - onCount$) and the ratio $\frac{onCount}{off\ count}$ must be an integer.

If the above conditions are not met, the *onCount* will be adjusted to comply.

Output pulses cannot be entirely stopped, only slowed to a period of 1.2(0.12)(hr).

Oneshot Pulse Output

A single TTL pulse can be output by setting the *pulses* field in the Rate Event to 1. However, hardware restrictions of the DAS-8 timers do not allow exact compliance with the DriverLINX API. The pulse output is inverted (active low); the Intel 8254 cannot generate a single active high pulse. A warning message about inverted pulse levels is always returned by DriverLINX when using the DAS-8.

To implement oneshot pulse outputs, DriverLINX uses Mode 0 of the Intel 8254 (pulse on terminal count): Output goes low when counter is loaded and remains low until end of count. The gate must be high for counting. Actual delay is *onCount* + mode setup time (as loading control register forces output low).

Note: Only the *onCount* determines duration; the *period* count is ignored.

Time Interval Measurements

DriverLINX does not support Time Interval Measurements using the DAS-8.

Index

Numerics

4–20 mA Current Loops
DAS8(LT) 4-16

A

A/D Conversion Delay
configuration using DriverLINX C6

A/D Data Lost
monitoring using DriverLINX C7

Accessories 1-5

ADC: *see* Analog-to-digital converter

Address
editing in DriverLINX 3-27

Adobe Acrobat
for DriverLINX
installing 3-23
installing 3-24

Analog common 4-9

Analog I/O panel
in DriverLINX
description of 1-3
using to test configuration 3-26

Analog input
features 2-2
ranges 2-5

Analog input
channels
switching to differential or single-
ended 3-11
DriverLINX subsystem 3-11

Analog Input Initialization
DriverLINX configuration of DAS8
C3

Analog Input Subsystem
DriverLINX configuration for DAS8
C3

Analog output
DAS8/AO 4-12

Analog Output Initialization
configuration in DriverLINX C7

Analog Output Subsystem
configuration in DriverLINX C7

Analog-to-digital converter 2-2

Analog trigger 2-17

Asynchronous
data transfer mode 3-13

Attaching expansion boards 4-1
EXP-16 and EXP-16/A 4-6
EXP-GP 4-7

Attaching screw terminal accessories 4-1
STA-08 / STA-08PGA 4-5
STC-37 4-3

Attaching signals: *see* Connecting signals

Automatic channel scanning 2-7, 2-8

B

Background
data transfer mode 3-13

Base address 3-8

- Base address
 - default used by DriverLINX 3-8
- Bipolar input range type 2-5
- Block diagram 2-2
- Board components
 - DAS-8 3-3, 3-4
 - DAS-8/PGA(G2) 3-5, 3-6
- Board installation 3-25

C

- C/C++
 - function libraries in software for applications in 1-3
- C-1800 cable 1-6, 4-3
- Cables
 - C-1800 1-6, 4-3
 - S-1800 1-6, 4-3
- Calibration
 - equipment 5-1
 - potentiometers 5-2
 - test points 5-2
- Calibration utility in DriverLINX
 - description of 1-4
- Cascaded mode 2-12
- Channel
 - automatic scanning of 2-8
 - list mode 2-8

- Channels
 - multiple
 - acquiring data from 2-7
- Channels, analog input 2-3
 - expansion 2-8
 - selection 2-7
- Common 4-9
- Commonly used interrupt levels 3-14
- Commonly used I/O addresses 3-9
- Common-mode voltages 2-6
- Configuration
 - hardware (DAS-8) 3-3, 3-4
 - hardware (DAS-8/PGA(G2)) 3-5, 3-6
 - options 3-7
- Configuration 3-11
- Configuring the board 3-7
 - base address 3-8
 - input configuration 3-12
 - interrupt level 3-13
- Connecting multiple expansion boards 2-9, 4-8
- Connecting signals 4-9
 - counter/timer I/O 4-14
 - differential inputs 4-11
 - digital I/O 4-13
 - external conversion clock 4-13
 - external interrupt 4-13
 - hardware trigger and gate 4-13
 - single-ended inputs 4-10
- Connector, main I/O: *see* Main I/O connector
- Conversion clocks 2-11
- Conversion frequency 2-2
- Conversion rate: *see* Conversion frequency

Converter: *see* Analog-to-digital converter
Counter/timer
 modes 2-20
 see also 8254 counter/timer circuitry
Counter/Timer Initialization
 in DriverLINX configuration C12
Counter/Timer Interrupt
 in DriverLINX configuration C12
Current output
 DAS-8/AO board 4-12

D

Daisy-chaining multiple expansion boards
 2-9, 4-8
DAS-8
 Specifications A-1
DAS-8 board components 3-3, 3-4
DAS-8 series
 configuration using DriverLINX 3-25
 includes DAS-8/LT,
 DAS-8/PGA(G2), and
 DAS-8/AO 1-1
 standard software package 1-3
DAS-8 Series standard software package
 3-21
DAS-8/AO
 Specifications A-5
 wiring output signal 4-12
DAS-8/LT
 Specifications A-8
DAS-8/PGA
 Specifications A-4
DAS-8/PGA(G2) board components 3-5,
 3-6

DAS8LT
 reference voltage 4-16
Data Coding
 DriverLINX configuration of DAS8
 C5
Data transfer techniques
 specifying 3-13
Default settings: *see* Power-up settings
Delphi
 function libraries for writing
 application programs in 1-3
Differential inputs
 connecting 4-11
Differential signals
 see also Input configuration
Digital common 4-9
Digital I/O
 connecting signals 4-13
 features 2-19
Digital Input and Output Subsystems
 configuration using DriverLINX C10
Digital trigger: *see* Hardware trigger
DIP switches: *see* Switches
Documentation
 for DriverLINX
 installing 3-23
Documentation for 8254 2-26
DriverLINX 3-11
 browser map 3-24
 configuring for DAS-8 boards 3-26
 description of 1-3
 hardware and software requirements
 1-1
Implementation Notes C1
 installation preparation 3-22
 installing 3-24

- Modes supported by DAS-8 Series C1
 - standard software package 1-3
 - using Learn DriverLINX 3-26
- DriverLINX utilities
 - included in software package 3-22
- Drivers
 - for DriverLINX
 - installing 3-23

E

- 8254 counter/timer circuitry 2-11, 2-20
 - connecting signals 4-14
- 8254 documentation 2-26
- End-of-conversion interrupt 2-18, 2-26
- Equipment, calibration 5-1
- Error handling 6-1
- Event Counting
 - in DriverLINX configuration C12
- Event viewer
 - in DriverLINX
 - using for troubleshooting 6-1
- EXP-16 and EXP-16/A expansion boards 1-5
 - attaching 4-6
- Expansion board
 - configuring in DriverLINX 3-11
- Expansion board configuration
 - DriverLINX dialog
 - for expansion channels 2-7
- Expansion boards 2-8
 - attaching 4-1

- daisy-chaining 4-8
- EXP-16 and EXP-16/A 1-5
- EXP-GP 1-5
 - powering 2-27
- EXP-GP expansion board 1-5
 - attaching 4-7
- External Clocking
 - configuration in DriverLINX C8
 - DriverLINX configuration of DAS8 C5
- External conversion clock 2-12
 - connecting 4-13
- External interrupt 2-26
 - connecting 4-13
- External Triggering
 - configuration in DriverLINX C7

F

- Foreground
 - data transfer mode 3-13
- Frequency Measurement
 - in DriverLINX configuration C13

G

- Gains 2-5
- Gate 2-16
 - connecting signal 4-13
- Ground: *see* Common
- Group of channels: *see* Automatic channel scanning

H

- Hardware
 - requirements for DAS-8 1-1
- Hardware components
 - DAS-8 3-3, 3-4
 - DAS-8/PGA(G2) 3-5, 3-6
- Hardware conversion clock: *see* External conversion clock, Internal conversion clock
- Hardware gate: *see* Gate
- Hardware trigger 2-14
 - connecting 4-13
- Hardware-triggered strobe mode 2-25

I

- Input configuration 3-12
- Input range types: *see* Bipolar input range type, Unipolar input range type
- Installation
 - DriverLINX preparation 3-22
- Installing
 - board 3-25
 - software 3-21
- Interfaces
 - for DriverLINX
 - installing 3-23
- Internal conversion clock 2-11
- Interrupt
 - setting for data transfer modes 3-13
- Interrupt levels 3-13
 - commonly used 3-14
- Interrupts 2-18, 2-26
- I/O addresses, commonly used 3-9

J

- Jumper 3-13

L

- LabVIEW
 - function libraries for writing application programs in 1-3
- Learn DriverLINX
 - program in DriverLINX
 - description of 1-3
 - used to configure DAS-8 boards 3-26
- Logical device
 - selecting for configuration in DriverLINX 3-27

M

- Main I/O connector 4-1
 - pin assignments (DAS-8) 4-2, B-2
 - pin assignments (DAS-8/AO) B-6
 - pin assignments (DAS-8/PGA(G2)) 4-2, 4-3, B-4
- Multi-channel list mode
 - for acquiring data 2-8
- Multiple channels: *see* Automatic channel scanning
- Multiplexer
 - using with DAS8/PGA or DAS8/PGA-G2 3-11

N

Normal mode 2-12

O

Oneshot Pulse Output
in DriverLINX configuration C15
Overvoltage protection 2-6

P

Pacer clocks: *see* Conversion clocks
PGA: *see* Programmable gain amplifier
Pin assignments
DAS-8 4-2, B-2
DAS-8/AO B-6
DAS-8/PGA(G2) 4-2, 4-3, B-4
Potentiometers 5-2
Power 2-27
Power-up settings
conversion clock 2-11
interrupt source 2-27
Problem isolation 6-2
Programmable gain amplifier 2-5
Programmable one-shot mode 2-21
Protection 2-6
Pulse on terminal count mode 2-20
Pulse Output
in DriverLINX configuration C14

R

Range of channels: *see* Automatic channel scanning
Ranges, analog input 2-5

Rate generator mode 2-22
Reference voltage
DAS8(LT) 4-16
Resolution 2-2

S

S-1800 cable 1-6, 4-3
Screw terminal accessories 2-9, 4-8
attaching 4-1
STA-08 1-5
STA-08PGA 1-5
STC-37 1-5
Setting
base address 3-8
input configuration 3-12
interrupt level 3-13
Signal conditioning 1-5, 2-8
Single channel selection 2-7
Single-ended inputs
connecting 4-10
Single-ended signals
see also Input configuration
Slot size 3-25
Software 3-21
Software
requirements for DriverLINX 1-1
Software conversion clock 2-11
Software trigger 2-14
Software-triggered strobe mode 2-24
Square-wave generator mode 2-23
STA-08 / STA-08PGA screw terminal accessory 1-5
attaching 4-5
Standard software 3-21
STC-37 screw terminal connector 1-5
attaching 4-3

- Switches 3-8
 - input configuration 3-12
- Synchronizing conversions 2-14, 4-14
- Synchronous
 - data transfer mode 3-13

T

- Test panel
 - DriverLINX utility
 - description of 1-4
- TestPoint
 - function libraries for writing
 - application programs in 1-3
- Test points 5-2
- Time base 2-11
- Trigger
 - analog
 - programming 2-17
 - digital
 - programming 2-17
- Triggers 2-14
- Troubleshooting 6-1

- Turbo Pascal
 - function libraries for writing
 - application programs in 1-3

U

- Unipolar input range type 2-5
- Unpacking the board 3-2
- Utility programs
 - configuration 3-11

V

- Visual Basic
 - function libraries for writing
 - application programs in 1-3
- Voltage output
 - DAS-8/AO board 4-12
- Voltage reference
 - DAS8 and DAS8/LT 4-16

W

- Wiring signals: *see* Connecting signals

Specifications are subject to change without notice.

All Keithley trademarks and trade names are the property of Keithley Instruments, Inc. All other trademarks and trade names are the property of their respective companies.



Keithley Instruments, Inc.

28775 Aurora Road • Cleveland, Ohio 44139 • 440-248-0400 • Fax: 440-248-6168
1-888-KEITHLEY (534-8453) • www.keithley.com

Sales Offices: BELGIUM:

Bergensesteenweg 709 • B-1600 Sint-Pieters-Leeuw • 02-363 00 40 • Fax: 02/363 00 64

CHINA:

Yuan Chen Xin Building, Room 705 • 12 Yumin Road, Dewai, Madian • Beijing 100029 • 8610-6202-2886 • Fax: 8610-6202-2892

FINLAND:

Tietäjantie 2 • 02130 Espoo • Phone: 09-54 75 08 10 • Fax: 09-25 10 51 00

FRANCE:

3, allée des Garays • 91127 Palaiseau Cédex • 01-64 53 20 20 • Fax: 01-60 11 77 26

GERMANY:

Landsberger Strasse 65 • 82110 Germering • 089/84 93 07-40 • Fax: 089/84 93 07-34

GREAT BRITAIN:

Unit 2 Commerce Park, Brunel Road • Theale • Berkshire RG7 4AB • 0118 929 7500 • Fax: 0118 929 7519

INDIA:

Flat 2B, Willocrissa • 14, Rest House Crescent • Bangalore 560 001 • 91-80-509-1320/21 • Fax: 91-80-509-1322

ITALY:

Viale San Gimignano, 38 • 20146 Milano • 02-48 39 16 01 • Fax: 02-48 30 22 74

JAPAN:

New Pier Takeshiba North Tower 13F • 11-1, Kaigan 1-chome • Minato-ku, Tokyo 105-0022 • 81-3-5733-7555 • Fax: 81-3-5733-7556

KOREA:

2FL., URI Building • 2-14 Yangjae-Dong • Seocho-Gu, Seoul 137-888 • 82-2-574-7778 • Fax: 82-2-574-7838

NETHERLANDS:

Postbus 559 • 4200 AN Gorinchem • 0183-635333 • Fax: 0183-630821

SWEDEN:

c/o Regus Business Centre • Frosundaviks Allé 15, 4tr • 169 70 Solna • 08-509 04 679 • Fax: 08-655 26 10

SWITZERLAND:

Kriesbachstrasse 4 • 8600 Dübendorf • 01-821 94 44 • Fax: 01-820 30 81

TAIWAN:

1FL., 85 Po Ai Street • Hsinchu, Taiwan, R.O.C. • 886-3-572-9077 • Fax: 886-3-572-9031