

Resistance Measurements Systems w/Sub PPM Accuracy - $1\mu\Omega$ to $1G\Omega$

Duane Brown, Measurements International

Abstract:

Two techniques are described for measuring resistance ratios from $1\mu\text{Ohm}$ to $1G\text{ Ohm}$ using the direct current comparator bridge and the binary voltage divider principles with uncertainties in the sub PPM level. The paper outlines the advantages and disadvantages of the two techniques for use in primary standards for the measurement of resistance. Both techniques are based on the latest research performed by the National Research Council of Canada (NRCC).

Introduction:

The measurement of resistance ratios depends on either of two techniques:

- Passing a current through two or more resistors in series and measuring the ratio of voltages developed across the resistors.
- Passing known ratios of current through each of a pair of resistors until the voltage drop developed across each resistor is the same.

An adaptation of the first technique is to measure voltage ratios by means of a conventional potentiometer or with a DVM. This approach has limited usefulness, being a sequential measurement where the stability of the source voltage is important due to the linearity of the voltage measurement system and the change in range factors. With the introduction of the 25-bit potentiometer, based on the binary voltage divider (BVD), the situation has changed. A single voltage source of 10 volts with a short-term stability of a few parts in 10^8 is used to power the potentiometer and the series resistor pair in parallel with a DVM detector.

The direct current comparator (DCC) bridge is an example of the second technique.

In both the BVD method and the DCC method, at balance no current flows in the measuring leads and lead resistance is therefore unimportant when using four terminal connections. In the potentiometric method resolution and accuracy are limited by (and cannot be better than) the stability of the DVM detector. The BVD bridge method suffers from the disadvantage that when

scaling resistors in decade steps the same current must be passed through both resistors and the greatest power is dissipated in the largest resistor. This limits the dynamic range for sub ppm measurements for the BVD to 1000 ohms and higher. In the DCC method the greatest power is dissipated in the smallest resistor and the dynamic range for sub ppm measurements is limited by the current noise of the DCC comparator to 10,000 ohms and less. The DCC method also suffers from the disadvantage of using 2 terminal measurements above 10,000 ohms.

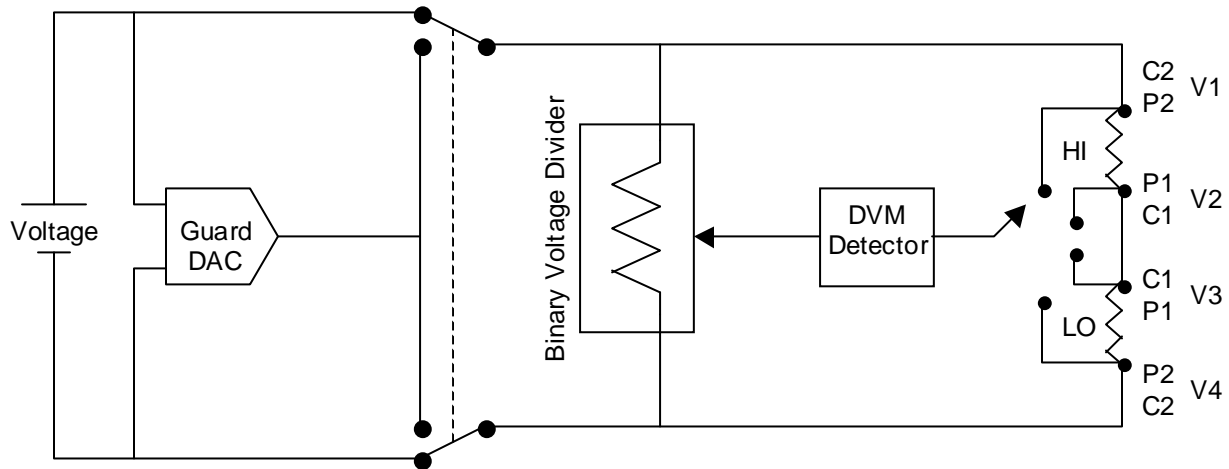

Figure 1: Binary Voltage Divider Principle

25 Bit Potentiometer Basic Operation:

The classic circuit of the BVD potentiometer is shown in Fig. 1 where a master/slave relationship exists between the BVD and the resistors under test, thus the stability of the common voltage source is not critical as long as it is stable during the time taken to make the four measurements called V_1 , V_2 , V_3 , V_4 .

The ratio of the two resistors is given by:

$$R = \frac{R_x}{R_s} = \frac{V_1 - V_2}{V_3 - V_4} = \frac{V_1/E - V_2/E}{V_3/E - V_4/E} = \frac{r_1 - r_2}{r_3 - r_4}$$

Over the range of 1,000 ohms to 1G Ohm all resistors are measured in a four terminal mode. This eliminates problems associated with lead resistance effects of two wire measurements made with the DCC method above 10,000 ohms.

For the automatic potentiometer, the standard deviation of the measurement is derived from the sensitivity and resolution of the DVM being used as the detector (S_{r1}). For the Fluke Model 8842, the resolution is estimated at ± 0.15 ppm and the short-term noise stability of the source is estimated to be less than 0.1 ppm for the time of measurement that is required. Experience with the binary voltage divider suggests that the calibration of the divider is consistent to within 0.02 ppm. When using the Hewlett Packard 3458A in the guarded mode, the resolution of the DVM is estimated at < 0.1 ppm over the range from 10,000 ohms to 10M Ohms and 1 ppm at 1G Ohm. The accuracy of the DVM is unimportant as the DVM is only used on the 1.2 millivolt range and is only used as a null detector.

For a typical 1:1 comparison of four terminal resistors the estimated uncertainty of the ratio measurement with $E = 10V$ is = 0.02 ppm.

$$\left(\frac{S_R}{R} \right)^2 = \left(\frac{[S_{r1}]^2 [S_{r2}]^2}{[1.0 - 0.5]^2} + \frac{[S_{r3}]^2 [S_{r4}]^2}{[0.5 - 0.0]^2} \right)$$

And for a typical 10:1 ratio measurement of four terminal resistors, $r_1=1.0$, $r_2=0.09$, $r_3=0.09$, $r_4=0.0$, the estimated uncertainty of the ratio measurement with $E = 10$ volts = 0.035 ppm.

A limit of 10 mW power dissipation has been arbitrarily chosen as the working limit for all resistors. Seven supply voltages have also been considered as follows:

E	R (1:1)	R (N:1)
1 V	> 25 ohm	> 100 ohm
3.2 V	> 250 ohm	> 1000 ohm
10 V	> 2500 ohm	> 10000 ohm
32 V	> 25000 ohm	> 100000 ohm
50 V	> 62500 ohm	> 1000000 ohm
100 V	> 250000 ohm	> 10000000 ohm

Table 1: Constraints due to power dissipation limits

Table 2 has been constructed from a practical point of view using an HP 3458 as the DVM detector and a stable zener voltage with an equivalent internal impedance of 100 milliohms. It will be appreciated that a calibrated voltage is not required; the major requirement is that the source be stable and noise free. Table 2 also illustrates the uncertainties for ratio measurements of 1:1, 10:1, 1:10 and 100:1.

E	(1:1)	(10:1)	(1:10)	(100:1)
0.1 V	1.0	0.5	5.0	20.0
1 V	0.5	0.3	3.0	10.0
5 V	0.25	0.2	1.6	5.0
10 V	0.1	0.1	0.6	3.0
20 V	0.1	0.1	0.33	2.0
50 V	0.1	0.1	0.15	1.0
100 V	0.1	0.1	0.1	0.5

Table 2: Uncertainties (95% Confidence) for Ratio Measurements

DCC Resistance Bridge Basic Operation:

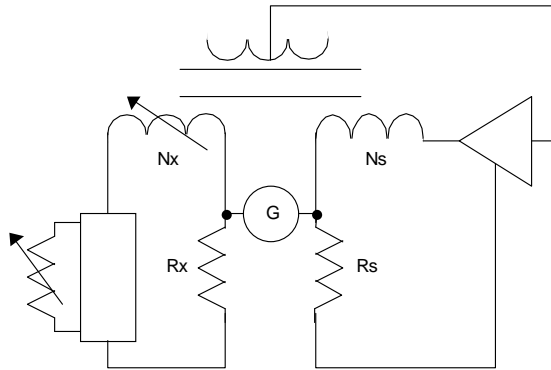

Figure 2: DC Comparator Bridge

The two resistors to be compared, R_x & R_s (Figure 2), are supplied from different current sources and the ratio of the two currents is measured when the voltage drops across the two resistors are equal and opposite. One or both of the current sources can be adjusted until a voltage balance across the two resistors is obtained. In our case, the current (I_x) is fixed at a level dependent on the desired sensitivity and the required power level for R_x . The current (I_s) is adjusted to obtain a voltage balance across the two resistors as indicated by the nanovolt detector (nV). The current comparator is then used to maintain an ampere-turn balance between the primary and secondary windings by adjusting the secondary current while the N_x turns are being adjusted by the central processing unit (CPU). The zero flux core condition in the current comparator is sensed by the flux detector (D) and fed back to control the I_s current. The CPU monitors the voltage at the nV detector and adjusts the N_x turns to maintain zero volts difference across the two resistors.

When (D) indicates zero flux:

$$I_s N_x = I_x N_s$$

$$\frac{I_x}{I_s} = \frac{N_x}{N_s}$$

$$\frac{R_x}{R_s} = \frac{I_s}{I_x} = \frac{N_x}{N_s}$$

$$\text{then } R_x = \frac{N_x}{N_s} R_s$$

At balance and under four terminal conditions, there is no current flowing in the potential leads and the Direct Current Comparator Bridge has the principal advantages of the potentiometric system. Because of the automatic ampere-turn balance there is no need for current stability. The unique advantage of the Current Comparator System is that the ratio of power dissipation in the compared resistors is the inverse of the ratio of resistance. This instrument has a useful range of operation of 0.1 ohm to 10K Ohm at currents from 10m ampere to 150m ampere.

The main disadvantage of the current comparator is the limitations of the current and voltage noise associated to the current comparator and the nanovolt detector. The current noise of the comparator is calculated as follows:

Current Noise:

$$\text{Current noise limit} = 0.05 \times 10^{-6} \text{ AT} / I_s \times N_s \text{ (slave turns)}$$

$$\text{If } I = 1 \text{ mA, then the current noise limit} = 0.05 \times 10^{-6} / 10^{-3} \times 800 \text{ turns} = 0.0625 \text{ ppm}$$

From the above equation it is evident that as you decrease the number of turns on the N_s winding the current noise increases and as you increase the resistance range the current noise, for a given voltage applied across the resistor, increases as follows:

For a 1M Ohm measurement at 100 volts $I = 0.1 \text{ mA}$

$$\text{For } I = 0.1 \text{ mA, then the current noise limit} = 0.05 \times 10^{-6} / 10^{-4} \times 800 \text{ turns} = 0.625 \text{ ppm}$$

and for a 600 turn N_s winding the current noise is increased to = 0.8333 ppm.

Voltage Noise:

Voltage noise limit for a 1 Ohm resistor = $5 \times 10^{-10} \text{ V} / \text{IsRs}$

If $I = 10 \text{ mA}$, then the voltage noise limit = $5 \times 10^{-10} / 10^{-2} \times 1 = 5 \times 10^{-7}$

Accuracy Specifications for DCC Bridge:

Ohms	E	1:1	10:1	Milliwatts
1 ohm	0.1 V	0.1	0.1	10
10 ohm	0.3 V	0.1	0.1	9
100 ohm	1.0 V	0.1	0.1	10
1K ohm	1.0 V	0.1	0.1	9
10K ohm	10 V	0.1	0.1	10
100K ohm	30 V	0.2	0.2	9
1M ohm	100 V	0.625	0.625	10
10M ohm	100 V	6.25	6.25	1
100M ohm	100 V	62.5	62.5	0.1

Table 3: Uncertainties (95% Confidence) for Ratio Measurements

The above table does not include any uncertainties for 2 terminal measurements above 10,000 ohms. Increasing the voltage can decrease the contributions of the current noise level uncertainty, but this increases the uncertainty due to the instability of the resistors caused by increased power dissipation and voltage coefficients of the resistor.

Measurements Below 1 Ohm using the Current Comparator:

To extend the range of the current comparator lower in resistance and higher in current while maintaining sub PPM accuracy it is necessary to cascade another current comparator (Figure 3).

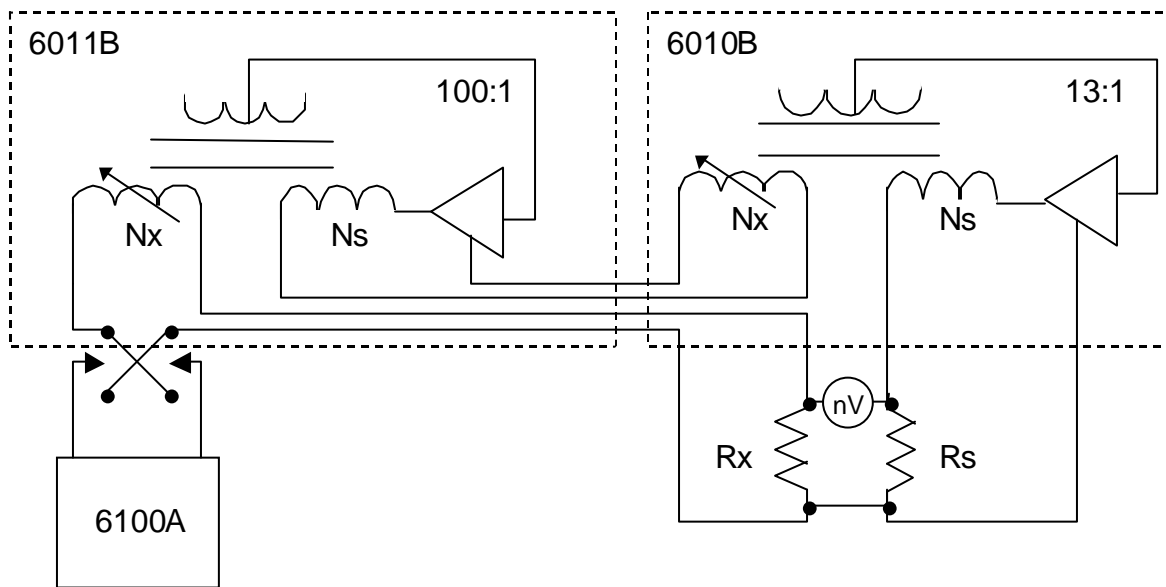

Figure 3: Cascading MI 6010B/6011A, 1000:1 Current Comparators

This involves reconfiguring the first current comparator to allow it to accept an external source for its I_x current from another current comparator.

The second current comparator is similar to the first. The two resistors to be compared are supplied from different current sources and the ratio of the two currents is measured when the voltage drops across the two resistors are equal and opposite. In this case, the current (I_x Ext.) is fixed at a level dependent on the desired sensitivity and the required power level for R_x . It is supplied from an external current source (HP6672A). The current (I_s Ext.) which now is (I_x) for the 6010B is adjusted to maintain zero flux on the extender core by feedback from the flux detector (D Ext.) and a signal proportional to (N_x Ext.) and (I_x Ext.). The current (I_s) is adjusted to obtain a voltage balance across the two resistors as indicated by the nanovolt detector (nV). The current comparator is then used to maintain an ampere-turn balance between the primary and secondary windings by adjusting the secondary current while the N_x and (N_x Ext.) turns are

being adjusted by the central processing unit (CPU). The zero flux core condition in the current comparator is sensed by the flux detector (D) and fed back to control the I_s current. The CPU monitors the voltage at the nV detector and adjusts the N_x and (N_x Ext.) turns to maintain zero volts difference across the two resistors

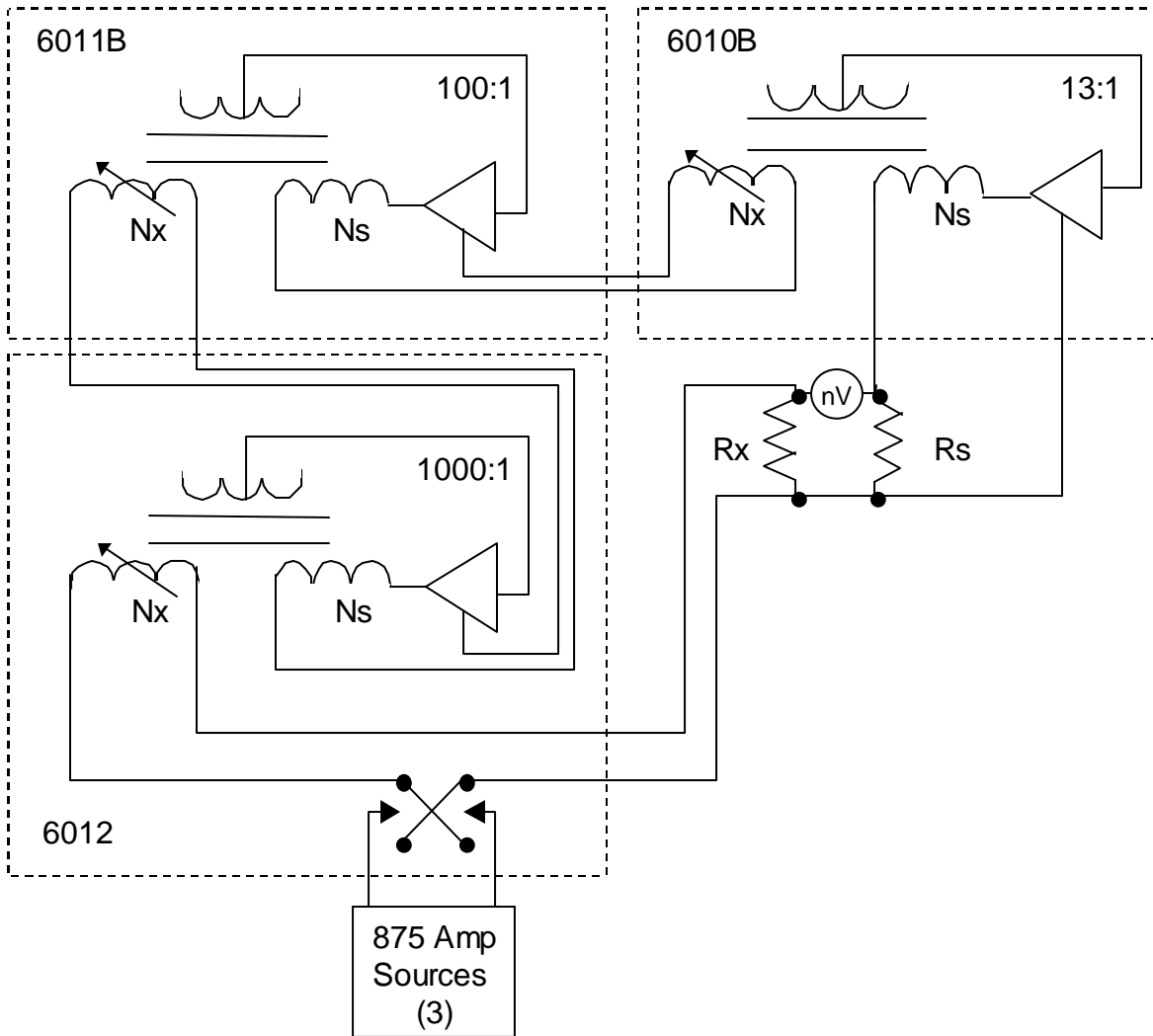

Figure 4: Range Extender (6012) added to cascading current comparators and power supplies

When ratios greater than 1000:1 or currents larger than 100 amperes are required then a second level of extension is required. This second level of extension is done with a fixed ratio extender that has a ratio of 1000:1 or 2000:1 and current compliance of up to 20,000 amperes. These are automatically balanced extenders but must be manually setup in the system.

Accuracy Specifications:

Accuracy (2s) (PPM)			
Range (W)	6010B	6010B/6011A	6010B/6011A/6012
.000001 to .00001	-	-	1
.00001 to .0001	-	-	1
.0001 to .001	-	2	1
.001 to .01	< 5	.2	-
.01 to .1	< .5	.2	-
.1 to 10K	< .1	-	-
10K to 10K	< .2	-	-

Figure 4: Accuracy specifications for DCC Comparator Bridge

Summary:

The techniques of using a direct current comparator bridge and BVD potentiometer offer several advantages over a DCC comparator alone, such as:

- Improved accuracy over the full range.
- Improved current noise levels for values above 10K Ohms
- Improved reliability of measurements due to lower voltage and power coefficients.
- Automation - the full range of resistance for each system can be automated without manual intervention.
- Each system can be used in separate environmental conditions(humidity, air currents, shielding and guarding etc.)
- System speed resulting in increased throughput and productivity.

References:

Macmartin & Kusters, "Direct Current Comparator", IEEE Transactions on Magnetics, Dec. 1965

D. Brown, Measurements International, "An Automated DC Current Comparator Resistance Bridge"

A. F. Dunn "Measurement of Resistance Ratios in the Range to 100 Megohms" IEE Transactions on Instrumentation and Measurement, Vol 40. NO. 2 April 1991.