

**AIR FORCE TO 33A1-13-496-1
NAVELEX 0969-LP-170-0010**

TECHNICAL MANUAL

**OPERATION AND MAINTENANCE INSTRUCTIONS
WITH
ILLUSTRATED PARTS BREAKDOWN**

**OSCILLOSCOPE
(100 MHz BANDWIDTH)
AN/USM-425(V)1
Model 465M
NSN 6625-01-032-6914**

Published under authority of the Secretaries of the Air Force and Navy

15 MARCH 1977

INSERT LATEST CHANGED PAGES. DESTROY SUPERSEDED PAGES.

LIST OF EFFECTIVE PAGES

NOTE: The portion of the text affected by the changes is indicated by a vertical line in the outer margins of the page. Changes to illustrations are indicated by miniature pointing hands. Changes to wiring diagrams are indicated by shaded areas.

Dates of issue for original and changed pages are:

Original015 MAR 77

TOTAL NUMBER OF PAGES IN THIS PUBLICATION IS 257 CONSISTING OF THE FOLLOWING:

Page No.	*Change No.	Page No.	*Change No.	Page No.	*Change No.
Title	0	4-46 Blank	0	6-28 Blank	0
A	0	5-1 - 5-55	0	7-1 - 7-6	0
i - v	0	5-56 Blank	0	8-0 - 8-68	0
vi Blank	0	6-1 - 6-3	0	9-1 - 9-11	0
vii	0	6-4 Blank	0	9-12 Blank	0
1-0 - 1-8	0	6-5 - 6-23	0	10-1 - 10-12	0
2-1 - 2-3	0	6-24 Blank	0	11-1	0
2-4 Blank	0	6-25	0	11-2 Blank	0
3-1 - 3-3	0	6-26 Blank	0		
3-4 Blank	0	6-27	0		
4-1 - 4-45	0				

*Zero in this column indicates an original page.

TABLE OF CONTENTS

Section/Para	Page	Section/Para	Page
LIST OF ILLUSTRATIONS	iii	IV OPERATION INSTRUCTIONS (cont)	
LIST OF TABLES	v	4-3 DETAILED CIRCUIT OPERATION	4-4
SAFETY SUMMARY	vii	a. Vertical Module	4-4
		(1) CH 1 and CH 2 Input	4-4
		(2) CH 1 and CH 2 Preamplifier and	
		Vertical Switching	4-5
		(3) Vertical Switching Control	4-5
		(4) Delay Line Driver and Delay Line . .	4-7
		(5) Vertical Amplifier.	4-8
I INTRODUCTION AND GENERAL		b. Horizontal Module	4-8
INFORMATION	1-1	(1) Trigger Input Amplifiers and	
1-1 INTRODUCTION	1-1	Trigger Switching.	4-8
a. Manual Purpose	1-1	(2) A Trigger Generator	4-9
b. Manual Scope	1-1	(3) B Trigger Generator	4-13
c. Manual Arrangement.	1-1	(4) A Sweep Generator.	4-13
1-2 USE OF WARNING, CAUTION, AND		(5) B Sweep Generator	4-16
NOTE SYMBOLS	1-1	(6) Horizontal Preamplifier	4-19
1-3 GENERAL INFORMATION	1-1	(7) +A GATE OUT Amplifier	4-20
a. Equipment Description	1-1	(8) +B GATE OUT Amplifier.	4-20
b. Accessories Supplied.	1-1	(9) Sweep Control	4-20
c. Leading Particulars	1-2	c. Main Module	4-23
II SPECIAL TOOLS AND TEST EQUIPMENT . 2-1		(1) Z Axis Amplifier	4-23
2-1 SPECIAL TOOLS.	2-1	(2) Crt Circuit.	4-24
2-2 TEST EQUIPMENT	2-1	(3) Horizontal Amplifier.	4-26
2-3 CONSUMABLE MATERIALS	2-1	(4) +B GATE OUT Amplifier.	4-26
2-4 RACKMOUNTING ACCESSORY.	2-3	(5) Calibrator	4-28
		(6) Low-Voltage Power Supplies.	4-28
III PREPARATION FOR USE AND SHIPMENT. 3-1		4-4 FUNCTIONS OF CONTROLS, CON-	
3-1 PREPARATION FOR USE	3-1	NECTORS, AND INDICATORS.	4-29
a. Unpacking the Instrument	3-1	4-5 OPERATING CONSIDERATIONS	4-35
b. Initial Inspection	3-1	a. Signal Connections	4-35
c. Faceplate Filter Installation	3-1	b. Loading Effect of Input Connections. .	4-35
d. Carrying Handle Positioning.	3-1	c. Coaxial Cables	4-35
e. Operating Voltage Selection.	3-1	d. Grounding	4-35
f. Power Cord Information	3-1	e. Graticule	4-35
3-2 OPERATING TEMPERATURE	3-3	f. Common-Mode Rejection.	4-36
3-3 PREPARATION FOR SHIPMENT	3-3	g. Cascaded Operation	4-36
IV OPERATION INSTRUCTIONS	4-1	h. Delayed-Sweep Magnification.	4-36
4-1 THEORY OF OPERATION.	4-1	4-6 INITIAL INSTRUMENT TURN-ON . . .	4-37
4-2 BASIC CIRCUIT FUNCTIONS.	4-1	4-7 PRELIMINARY ADJUSTMENTS	4-38
a. Vertical Module.	4-1	a. Initial Control Settings	4-38
b. Horizontal Module.	4-1	b. Intensity Adjustment	4-38
c. Main Module	4-4	c. Focus and Astigmatism Adjustment. . .	4-38
		d. Trace Rotation Adjustment	4-38
		e. Graticule Scale Illumination	4-39
		f. Probe Compensation	4-39

TABLE OF CONTENTS (cont)

Section/Para	Page	Section/Para	Page
IV		V	
OPERATION INSTRUCTIONS (continued)		MAINTENANCE INSTRUCTIONS (continued)	
4-8 NORMAL OPERATION	4-39	j. A and B Timing Switch Board Assembly Removal and Replacement	5-37
a. Beam Finder	4-39	k. A and B Timing Switch Disassembly	5-38
b. Intensity and Focus	4-40	l. Trigger Board Removal and Replacement.	5-39
c. Vertical Deflection system	4-40	m. Source and Coupling Switch Disassembly	5-40
d. Horizontal Deflection System.	4-40	n. Horizontal Board Removal and Replacement.	5-40
4-9 INSTRUMENT TURN-OFF	4-41	o. Sweep Board Removal and Replacement	5-40
4-10 APPLICATIONS	4-41	p. Graticule Illumination Board Removal and Replacement.	5-40
a. Peak to Peak Amplitude Measurement	4-41	q. Hybrid IC Removal and Replacement	5-40
b. Instantaneous Amplitude Measurement	4-42	r. VOLTS/DIV Attenuator Disassembly.	5-41
c. Dual Trace Phase Difference Measurement	4-42	s. Probe Disassembly and Repair.	5-43
d. High Resolution Phase Difference Measurement	4-43	t. Light Emitting Diode (LED) Replacement.	5-44
e. Time Duration and Frequency Measurement	4-43	u. Push Button, Shaft Extension, and Shaft Extension Adapter Removal and Replacement.	5-44
f. Rise Time Measurement.	4-43		
g. Differential Time Measurement.	4-43		
V		5-6 CALIBRATION.	5-45
MAINTENANCE INSTRUCTIONS.	5-1	a. Preliminary Calibration Set-Up Procedure.	5-45
5-1 OPERATIONAL CHECKOUT	5-1	b. +32 Volt Power Supply.	5-45
5-2 PREVENTIVE MAINTENANCE.	5-20	c. Crt Bias	5-45
a. Preventive Maintenance Schedule	5-20	d. Z-Axis Compensation	5-46
b. External Preventive Maintenance.	5-21	e. Y-Axis Alignment.	5-46
c. Internal Preventive Maintenance	5-22	f. Geometry	5-47
5-3 TROUBLESHOOTING	5-22	g. Calibrator.	5-47
a. Troubleshooting Aids	5-23	h. Dc Balance	5-47
b. Troubleshooting Techniques	5-30	i. Vertical Gain	5-47
5-4 CALIBRATION AND CHECKOUT AFTER REPAIR	5-32	j. Channel 2 Low Frequency Compensation.	5-47
5-5 COMPONENT REMOVAL, REPLACEMENT, AND DISASSEMBLY.	5-32	k. Channel 1 Low Frequency Compensation.	5-48
a. Cabinet Top and EMI Shield Removal and Replacement.	5-32	l. High-Frequency Compensation	5-49
b. Interconnecting Cables and Connectors	5-33	m. Trigger Hysteresis and Slope Centering	5-50
c. Rear Panel Assembly Removal and Replacement.	5-33	n. External Trigger Centering.	5-51
d. Cabinet Bottom Removal and Replacement.	5-34	o. Sweep Start-Stop	5-51
e. Vertical Module Removal.	5-34	p. Horizontal Gain.	5-52
f. Horizontal Module Removal	5-34	q. Magnifier Registration.	5-53
g. Cathode Ray Tube (Crt) Removal	5-35	r. B Sweep Timing	5-53
h. Shaft-Knob Removal	5-36	s. .5 μ s Timing	5-54
i. Interface Board Removal	5-36	t. 5 ns Timing	5-54
		u. X Gain.	5-54

TABLE OF CONTENTS (cont)

Section/Para	Page	Section/Para	Page
VI	DIAGRAMS.	6-1	
	6-1 INTRODUCTION	6-1	
	6-2 ARRANGEMENT	6-1	
	a. Schematic Diagrams	6-1	
	b. Symbols and Reference Designators.	6-1	
	6-3 WAVEFORMS AND VOLTAGE TEST CONDITIONS.	6-2	
VII	ILLUSTRATED PARTS BREAKDOWN INTRODUCTION	7-1	
	7-1 GENERAL	7-1	
	7-2 INTRODUCTION	7-1	
	7-3 MAINTENANCE PARTS LIST INTRODUCTION	7-1	
	7-4 INDENTATION.	7-1	
	7-5 FIGURE CROSS REFERENCE NOTES.	7-1	
	7-6 SIMILAR ASSEMBLIES	7-1	
	7-7 ATTACHING PARTS.	7-1	
	7-8 TEKTRONIX PART NUMBERING SYSTEM	7-2	
	7-9 EXPLANATION OF COLUMNS IN SECTION VIII	7-2	
VII	ILLUSTRATED PARTS BREAKDOWN INTRODUCTION (continued)		
	7-10 NUMERICAL INDEX INTRODUCTION	7-2	
	7-11 SOURCE, MAINTENANCE, AND RECOVERABILITY (SMR) CODE.	7-2	
	7-12 REFERENCE DESIGNATION INDEX INTRODUCTION	7-2	
	7-13 HOW TO USE THIS IPB	7-2	
	7-14 ABBREVIATIONS AND LETTER SYMBOL LIST	7-2	
	7-15 MANUFACTURER'S CODE CROSS REFERENCE LIST	7-3	
VIII	ILLUSTRATED PARTS BREAKDOWN MAINTENANCE PARTS LIST	8-1	
IX	ILLUSTRATED PARTS BREAKDOWN NUMERICAL INDEX	9-1	
X	ILLUSTRATED PARTS BREAKDOWN REFERENCE DESIGNATION INDEX	10-1	
XI	DIFFERENCE DATA SHEETS	11-1	

LIST OF ILLUSTRATIONS

Figure	Title	Page	Figure	Title	Page
1-0	AN/USM 425(V)1 with front cover.	1-0	4-7	Waveforms produced during A sweep operation	4-15
3-1	Removal and installation of faceplate filters	3-2	4-8	Simplified diagram of the B sweep generator.	4-17
3-2	Carrying handle positioning.	3-3	4-9	Waveforms produced during B sweep generation	4-18
3-3	Power section of rear panel	3-3	4-10	Functional block diagram of the sweep control integrated circuit and associated circuitry.	4-21
4-1	Overall block diagram (sheet 1 of 2)	4-2	4-11	Waveforms produced by holdoff control circuitry.	4-22
4-1	Overall block diagram (sheet 2 of 2)	4-3	4-12	Waveforms produced during AUTO sweep gate generation	4-23
4-2	Channel switching gates	4-6	4-13	Waveforms produced in the high-voltage oscillator	4-24
4-3	Trigger switching.	4-10			
4-4	Trigger signal paths with SOURCE set to NORM and COUPLING set to AC.	4-11			
4-5	A trigger generator.	4-12			
4-6	Simplified diagram of the A sweep generator	4-14			

LIST OF ILLUSTRATIONS (cont)

Figure	Title	Page	Figure	Title	Page
4-14	High-voltage rectifier	4-26	5-17	Crt and Z-Axis test point and adjustment locations	5-46
4-15	Dc restorer	4-27	5-18	Crt and Calibration test point and adjustment locations	4-57
4-16	(blank)		5-19	Vertical adjustment locations.	5-48
4-17	Graticule measurement markings	4-35	5-20	Trigger hysteresis and slope centering adjustment locations	5-50
4-18	Common-mode rejection of an undesired line-frequency	4-36	5-21	External trigger centering setup	5-51
4-19	Delayed sweep magnification	4-37	5-22	Trigger and horizontal adjustment locations	5-52
4-20	Probe compensation.	4-39	5-23	Sweep adjustment locations.	5-53
4-21	Example of peak to peak voltage measurement	4-42	5-24	5 nanosecond timing adjustment locations	5-55
4-22	Example of instantaneous voltage measurement	4-42	6-1	Schematic symbols	6-3
4-23	Example of dual trace phase difference measurement	4-43	FO-1 (Front)	Front and rear panel controls, connectors, and indicators.	6-5
4-24	Example of high resolution phase difference measurement	4-43	FO-1 (Rear)	A1/A3 Cam Switching, A2/A4 Attenuator, and A5 Vertical circuit board layouts and component locators.	6-6
4-25	Example of time duration and frequency measurement	4-44	FO-2 (Front)	CH 1 and CH 2 Input schematic diagram 1.	6-7
4-26	Example of rise time measurement.	4-44	FO-2 (Rear)	A5 Vertical circuit board layout and component locators	6-8
4-27	Example of time-duration measurement using A INTEN mode	4-44	FO-3 (Front)	Vertical Preamplifier and Switching schematic diagram 2.	6-9
4-28	Example of time-duration measurement using B DLY'D mode	4-45	FO-3 (Rear)	A5 Vertical circuit board layout and component locator.	6-10
5-1	Component value identification	5-24	FO-4 (Front)	Delay Line Driver Vertical Amplifier, and Interface Connector schematic diagram 3.	6-11
5-2	Troubleshooting chart (sheet 1 of 5)	5-25	FO-4 (Rear)	A6 Horizontal and A7 Trigger circuit board layouts and component locators	6-12
5-2	Troubleshooting chart (sheet 2 of 5)	5-26	FO-5 (Front)	Trigger schematic diagram 4	6-13
5-2	Troubleshooting chart (sheet 3 of 5)	5-27	FO-5 (Rear)	A6 Horizontal and A8 Sweep circuit board layouts and component locators	6-14
5-2	Troubleshooting chart (sheet 4 of 5)	5-28	FO-6 (Front)	Sweep and Horizontal Preamplifier schematic diagram 5.	6-15
5-2	Troubleshooting chart (sheet 5 of 5)	5-29	FO-6 (Rear)	A9 A Timing Switch and A10 B Timing Switch circuit board layouts and component locators	6-16
5-3	Semiconductor lead configurations	5-31	FO-7 (Front)	A and B Timing Switch and Interface Connector schematic diagram 6	6-17
5-4	Multiconductor connector identification	5-33	FO-7 (Rear)	Partial A11 Interface circuit board layout and component locator	6-18
5-5	Rear panel removal	5-34			
5-6	Cabinet bottom removal	5-35			
5-7	Vertical module removal.	5-36			
5-8	Horizontal module removal	5-37			
5-9	Shaft-knob removal	5-38			
5-10	Horizontal module board locator	5-38			
5-11	TIME/DIV switch disassembly	5-39			
5-12	Hybrid IC removal.	5-41			
5-13	VOLTS/DIV attenuator disassembly	5-42			
5-14	Probe BNC connector removal and replacement	5-44			
5-15	Light-emitting diode (LED) lead identification	5-44			
5-16	+32 volt test point and adjustment location	5-46			

LIST OF ILLUSTRATIONS (cont)

Figure	Title	Page	Figure	Title	Page
FO-8 (Front)	Horizontal Amplifier, + Gate, and Calibrator schematic diagram 7 . . .	6-19	8-7	Circuit Board Assembly, Horizontal Module	8-26
FO-8 (Rear)	Partial A11 Interface circuit board layout and component locator . . .	6-20	8-8	Circuit Board Assembly, Trigger (sheet 1 of 3)	8-30
FO-9 (Front)	Crt and Z Axis schematic diagram 8	6-21	8-8	Circuit Board Assembly, Trigger (sheet 2 of 3)	8-31
FO-9 (Rear)	Partial A11 Interface circuit board layout and component locator . . .	6-22	8-8	Circuit Board Assembly, Trigger (sheet 3 of 3)	8-32
FO-10 (Front)	Power Supply and Interface Connector schematic diagram 9	6-23	8-9	Circuit Board Assembly, A Timing (sheet 1 of 2)	8-36
FO-11 (Front)	Interconnect Wiring schematic diagram 10	6-25	8-9	Circuit Board Assembly, B Timing (sheet 2 of 2)	8-38
FO-12 (Front)	P6101 and P6104 Probe schematic diagram 11	6-27	8-10	Circuit Board Assembly, Horizontal	8-40
8-1	Oscilloscope, AN/USM-425(V)1	8-0	8-11	Circuit Board Assembly, Sweep (sheet 1 of 3)	8-43
8-2	Accessories and Cover Assembly.	8-2	8-11	Circuit Board Assembly, Sweep (sheet 2 of 3)	8-44
8-3	Cabinet and Handle Assembly	8-5	8-11	Circuit Board Assembly, Sweep (sheet 3 of 3)	8-45
8-4	Circuit Board Assembly, Vertical Module	8-7	8-12	Electron Tube Assembly.	8-50
8-5	Circuit Board Assembly, Vertical (sheet 1 of 4)	8-12	8-13	Main Chassis Assembly.	8-53
8-5	Circuit Board Assembly, Vertical (sheet 2 of 4)	8-13	8-14	Circuit Board Assembly, Interface (sheet 1 of 4)	8-58
8-5	Circuit Board Assembly, Vertical (sheet 3 of 4)	8-14	8-14	Circuit Board Assembly, Interface (sheet 2 of 4)	8-59
8-5	Circuit Board Assembly, Vertical (sheet 4 of 4)	8-15	8-14	Circuit Board Assembly, Interface (sheet 3 of 4)	8-60
8-6	Circuit Board Assembly, Cam Switch Channel 1 (sheet 1 of 2) . . .	8-22	8-14	Circuit Board Assembly, Interface (sheet 4 of 4)	8-61
8-6	Circuit Board Assembly, Cam Switch Channel 2 (sheet 2 of 2) . . .	8-24			

LIST OF TABLES

Number	Title	Page	Number	Title	Page
1-1	Electrical Characteristics.	1-2	4-2	Functions of Controls, Connectors, and Indicators.	4-30
1-2	Environmental Characteristics	1-7			
1-3	Physical Characteristics.	1-8	5-1	Operational Checkout Procedures.	5-1
2-1	Test Equipment List	2-1	5-2	Preventive Maintenance Schedule	5-20
2-2	Consumable Materials List.	2-3	5-3	External Inspection Checklist	5-21
			5-4	Internal Inspection Checklist	5-23
			5-5	Power Supply Tolerance and Ripple	5-30
4-1	Attenuation and Gain Switching Sequence	4-5	6-1	Reference Designators	6-1

SAFETY SUMMARY

The following are general safety precautions that are not related to any specific procedures and therefore may not appear elsewhere in this publication. These are recommended precautions that personnel must understand and apply during many phases of operation and maintenance.

KEEP AWAY FROM LIVE CIRCUITS

Electrical-shock hazards are present in this instrument. Operating personnel must observe safety regulations at all times and should not remove the protective covers unless they are qualified maintenance personnel. Do not replace components or repair the instrument unless it is disconnected from the line voltage source and turned off. Under certain conditions some components may retain dangerous potentials even when the instrument is unplugged and turned off. To prevent shocks, discharge and ground circuits that are being repaired.

DO NOT SERVICE OR ADJUST ALONE

Do not service or make internal adjustments to this instrument unless another person capable of giving first aid and resuscitation is present.

DO NOT OPERATE IN EXPLOSIVE ATMOSPHERE

Do not operate this instrument in an area where flammable gases or fumes are present. Such operation could cause an explosion.

GROUND THE INSTRUMENT

To prevent electrical-shock hazards, insert the power-cord plug only in proper mating power outlets.

SAFETY WARNING IDENTIFICATION

Personnel safety warnings that appear in the text of this manual are identified with the following symbol:



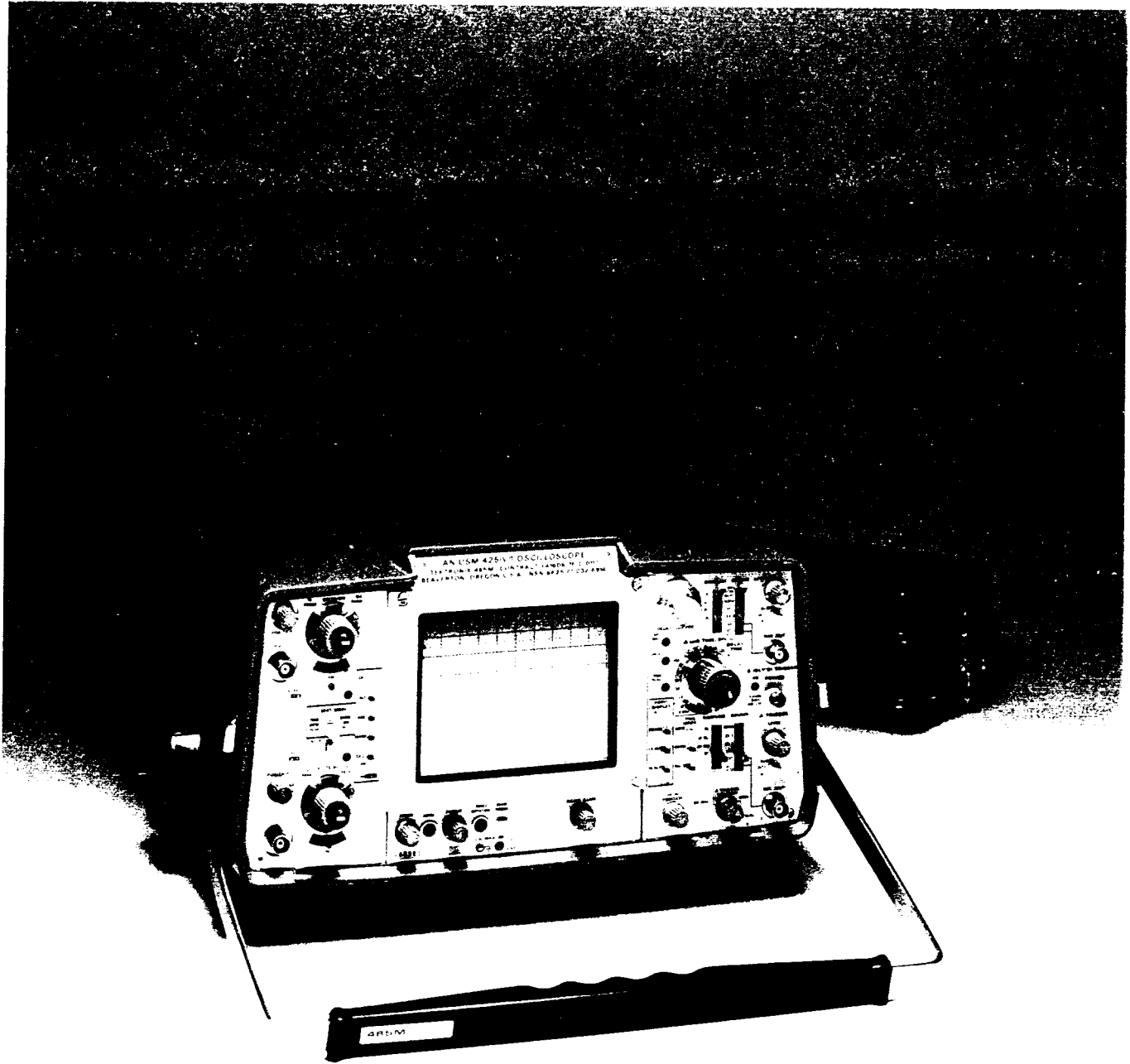

Figure 1-0. AN/USM-425(V)1 with cover.

SECTION I

INTRODUCTION AND GENERAL INFORMATION

1-1. INTRODUCTION

a. **Manual Purpose.** This manual provides instructions for operation and maintenance of the AN/USM-425(V)1 Oscilloscope and includes illustrated parts breakdown data. The AN/USM-425(V)1 is a Model 465M manufactured by Tektronix, Incorporated, Beaverton, Oregon.

b. **Manual Scope.** The instructions provided in this manual are intended to be performed at organizational or intermediate level maintenance activities using tools, test equipment, and spare parts authorized in their allowance lists and supply activities.

c. **Manual Arrangement.** This manual is separated into eleven sections as follows:

(1) **Section I, Introduction and General Information.** Contains the purpose, scope, and arrangement of the manual and a description of the instrument including its leading particulars and accessories.

(2) **Section II, Special Tools and Test Equipment.** Contains listings of tools, test equipment, and consumable materials needed to maintain the instrument.

(3) **Section III, Preparation for Use and Shipment.** Contains instructions for preparing the instrument for initial use and repackaging for shipment.

(4) **Section IV, Operation Instructions.** Contains instrument theory of operation; a description of controls, connectors, and indicators; special operating instructions; initial turn-on and adjustment procedures; normal operation familiarization procedures; and examples of instrument applications.

(5) **Section V, Maintenance Instructions.** Contains procedures to check out, perform routine maintenance, troubleshoot, repair, test, and adjust the instrument.

(6) **Section VI, Diagrams.** Contains wiring and schematic diagrams with associated data referenced in other sections of the manual. Also, may contain some illustrations to improve operation and maintenance of the instrument.

(7) **Section VII, Introduction to the Illustrated Parts Breakdown.** Contains information on how to use the illustrated parts breakdown data in Sections VIII through X.

(8) **Section VIII, Maintenance Parts List.** Contains the illustrated parts breakdown illustrations and parts descriptions.

(9) **Section IX, Numerical Index.** Contains a part number to figure and index cross reference listing.

(10) **Section X, Reference Designation Index.** Contains a reference designator to figure and index, and part number cross reference listing.

(11) **Section XI, Difference Data Sheets.** Provides a section for inserting information about different models, custom modifications, other accessories, etc., that may not be provided as part of the manual.

1-2. **USE OF WARNING, CAUTION, AND NOTE SYMBOLS.** Symbols are used throughout the manual text to highlight personnel safety warnings, precautions to prevent damage to the instrument, and special notes. These symbols are as follows:

 Personnel Safety Warnings

 Equipment Damage Precautions

NOTE Special Notes

1-3. GENERAL INFORMATION

a. **Equipment Description.** The AN/USM-425(V)1 is a solid state, dual channel, 100 megahertz bandwidth, delayed sweep, general purpose oscilloscope. Each vertical channel has ten calibrated deflection factors from 5 millivolts/division to 5 volts/division selected in a 1-2-5 sequence. The horizontal deflection system has calibrated sweep rates of 0.5 seconds/division to 0.05 microseconds/division in 22 steps. It also has delayed sweep rates of 50 milliseconds/division to 0.05 microseconds/division in 19 steps. A ten times magnifier expands each horizontal sweep rate to a maximum of 5 nanoseconds/division. An X-Y display mode is provided through vertical mode and horizontal sweep speed selection. The instrument with its detachable front cover and accessories is shown in Figure 1-0.

b. **Accessories Supplied.** Figure 8-2 illustrates and lists the accessories that are shipped with the instrument and stored in its front cover.

c. **Leading Particulars.** Tables 1-1 through 1-3 list the electrical, environmental, and physical characteristics of the AN/USM-425(V)1. The electrical characteristics are valid under these conditions: (1) the instrument has been calibrated (adjusted) as described in Section V at an am-

bient temperature between +20° and +30°C (+68° to +86°F), (2) the instrument is operating in an ambient temperature between -15° and +55°C (+5° to +131°F) and (3) the instrument has warmed-up for 20 minutes, or 5 minutes if above 0°C (+32°F).

Table 1-1. Electrical Characters

Item	Characteristic
VERTICAL DEFLECTION SYSTEM	
Deflection Factor	
Calibrated Range	5 millivolts/division to 5 volts/division in 10 calibrated steps in a 1-2-5 sequence.
Accuracy	Within 2% from 0° to +40°C (+32° to +104°F). Within 3% from -15° to 0°C (+5° to +32°F) and from +40° to +55°C (+104° to +131°F).
Uncalibrated Variable Range	Continuously variable between calibrated settings. Extends deflection factor to at least 12.5 volts/division.
Bandwidth at -3 dB points	Dc to at least 100 megahertz. A limit selector sets a bandwidth limit at 20 megahertz ±5 megahertz.
AC Low-Frequency Response at -3 dB points	
Without Probe or With P6101 Probe	10 hertz or less at all deflection factors.
With P6104 Probe	1 hertz or less at all deflection factors.
Maximum Input Voltage (dc or ac coupled)	±250 volts dc plus peak ac at 20 kilohertz. ±10 volts dc plus peak ac at 1 megahertz. ±5 volts dc plus peak ac at 100 megahertz.
Input Impedance	
Resistance	1 megohm within 2%.
Capacitance	Approximately 20 picofarads.
Channel Isolation	At least 100:1, dc to 10 megahertz. At least 50:1, 10 to 20 megahertz. At least 25:1, 20 to 50 megahertz. At least 15:1, 50 to 100 megahertz.
Common Mode Rejection Ratio	At least 25:1, dc to 10 megahertz. At least 10:1, 10 to 50 megahertz.
DC Drift	Not more than 0.1 centimeter/hour from 0° to +55°C (+32° to +131°F). Not more than 0.5 centimeter/hour from -15° to 0°C (+5° to +32°F).
DC Balance	Within 0.2 division over calibrated vertical deflection range.

Table 1-1. Electrical Characteristics—Continued

Item	Characteristic
Rise Time	3.5 nanoseconds or less from -15° to $+55^{\circ}\text{C}$ ($+5^{\circ}$ to $+131^{\circ}\text{F}$).
Input Coupling Modes	Ac, dc, and ground.
Vertical Display Modes	Channel 1, channel 2, alternate, chopped, and add (algebraic).
Chopped Mode Repetition Rate	Approximately 250 kilohertz.
Cascaded Operation	
Bandwidth	DC to at least 40 megahertz.
Sensitivity	Approximately 1 millivolt/division when terminated in 50 ohms at channel 1 input and both channels set to 5 millivolts/division deflection factor.
X-Y Operation	
Bandwidth	
X-Axis	Dc to at least 4 megahertz.
Y-Axis	Same as Vertical Deflection System.
Sensitivity (both axes)	Same as Vertical Deflection System Deflection Factor (X-Axis accuracy is 4%).
Variable Range	Same as Vertical Deflection System Uncalibrated Variable Range.
Input Impedance	Same as Vertical Deflection System Input Impedance.
Maximum Input Voltage	Same as Vertical Deflection System.
Display Phase Difference	Within 3° from dc to 50 kilohertz.
Polarity Inversion	Channel 2 only.
Channel 2 Signal Output	
Bandwidth	Dc to at least 40 megahertz when terminated into 50 ohms.
Voltage	One division of deflection provides approximately 50 millivolts when terminated into 1 megohm or 25 millivolts when terminated into 50 ohms.
Resistance	Approximately 50 ohms.
Dc Level	Approximately 0 volts.

Table 1-1. Electrical Characteristics—Continued

Item	Characteristic
HORIZONTAL DEFLECTION SYSTEM	
Sweep Modes	A Sweep, mixed, A intensified, and B delayed.
Sweep Rate	
Calibrated Range	
A Sweep	0.5 seconds/division to 0.05 microseconds/division in 22 steps in a 1-2-5 sequence. A ten times magnifier extends the maximum sweep rate to 5 nanoseconds/division.
B Sweep (delayed sweep)	50 milliseconds/division to 0.05 microseconds/division in 19 steps in a 1-2-5 sequence. A ten times magnifier extends the maximum sweep rate to 5 nanoseconds/division.
Accuracy	
Unmagnified	Within 2% from +20° to +30°C (+68° to +86°F). Within 3% from -15° to +55°C (+5° to +131°F). Within 6% below -15°C (+5°F).
Magnified	Within 3% from +20° to +30°C (+68° to +86°F). Within 4% from -15° to +55°C (+5° to +131°F).
Mixed Sweep	
A Sweep	Within 4%.
B Sweep	Within 2%.
Differential Time Measurement	For measurements of two or more major dial divisions.
+15° to +35°C	1% plus 0.1% of full scale sweep rate.
(+59° to +95°F)	
0° to +55°C	Add 1% to +15° to +35°C characteristic.
(+32° to +131°F)	
Below 0°C (+32°F)	Add 4% to +15° to 35°C characteristic.
Uncalibrated Variable	Continuously variable between calibrated settings at a 2.5:1 ratio.
Range (A Sweep only)	Extends the slowest A Sweep rate to at least 1.25 seconds/division.
Horizontal Linearity (unmagnified)	Within 0.25 minor division.
Magnifier Registration	Within 2.5 centimeters.
Position Drift	Not more than 0.1 centimeter/hour from 0° to +55°C (+32° to +131°F). Not more than 0.5 centimeter/hour from -40° to 0°C (-40° to +32°F).
Delayed Sweep Variable Delay	Continuously variable from 0.1 microseconds to at least 5 seconds after the start of A Sweep (depends on A Sweep rate).
Delayed Sweep Time Base Jitter	Less than 0.005% of ten times the A Sweep rate.

Table 1-1. Electrical Characteristics—Continued

Item	Characteristic
A Sweep Gate Output Amplitude	Approximately 5 volt positive pulse
Output Resistance	Approximately 1.5 kilohms.
B Sweep Gate Output	
Amplitude	Approximately 5 volt positive pulse.
Output Resistance	Approximately 500 ohms.
TRIGGERING (A and B SWEEP)	
Source	Normal, channel 1, channel 2, line (A Sweep only), external, external divided by 10, and starts after delay (B Sweep only).
Sensitivity	
DC Coupled	0.3 division internal or 50 millivolts external from dc to 25 megahertz; increases to 1.0 division internal or 150 millivolts external at 100 megahertz.
AC Coupled	0.3 division internal or 50 millivolts external from 30 hertz to 25 megahertz; increases to 1.0 division internal or 150 millivolts external at 100 megahertz.
LF Reject Coupled	0.3 division internal or 50 millivolts external from 50 kilohertz to 25 megahertz; increases to 1.0 division internal or 150 millivolts external at 100 megahertz; attenuates signals below about 15 kilohertz.
HF Reject Coupled	0.3 division internal or 50 millivolts external from 60 hertz to 5 kilohertz; attenuates signals below about 30 hertz and above about 50 kilohertz.
External Trigger Input	
Maximum Input Voltage	100 volts dc plus peak ac. 100 volts peak to peak ac at 1 kilohertz or less.
Input Resistance	1 megohm within 15%.
Trigger Jitter	0.5 nanoseconds or less at 100 megahertz with a 5 nanosecond/division sweep rate from -15° to $+55^{\circ}$ C ($+5^{\circ}$ to $+131^{\circ}$ F).
Trigger Holdoff	Continuously variable for holdoff to at least three times the sweep rate except at the 0.2 second and 0.5 second rates.
Trigger View Deflection Factor	
External	Approximately 100 millivolts/division.
External divided by 10	Approximately 1 volt/division.
Trigger Level Control Range	
External	At least ± 1 volt or 2 volts peak to peak.
External Divided by 10	At least ± 10 volts or 20 volts peak to peak.

Table 1-1 Electrical Characteristics—Continued

Item	Characteristic
Triggering Auto Free-running Frequency	Below 40 hertz.
Z-AXIS INPUT	
Sensitivity	Noticeable modulation at normal intensity with a 5 volt peak to peak input; positive-going signal decreases sensitivity.
Useable Frequency Range	Dc to at least 15 megahertz.
DC Input Resistance	Approximately 1.6 kilohms.
CALIBRATOR	
Output Voltage	1.0 volt within 1.0% from -15° to $+55^{\circ}$ C ($+5^{\circ}$ to $+131^{\circ}$ F).
Repetition Rate	Approximately 1 kilohertz.
Symmetry	Within 25%
Rise Time	Less than 1 microsecond.
DISPLAY	
Display Area	8 centimeters high by 10 centimeters wide.
CRT Phosphor	Type P31.
Trace Rotation Range	Adequate to align trace with horizontal center graticule line.
POWER REQUIREMENTS	
Line Voltage Ranges 116 Volts	100 to 132 volts rms.
232 Volts	200 to 264 volts rms.
Line Frequency	48 to 440 hertz.
Maximum Power Consumption	60 watts with 115 volt, 60 hertz input.
PROBES	
P6101	
Attenuation	1X.
Input Resistance	1 megohm.
Input Capacitance	32 picofarad.

Table 1-1. Electrical Characteristics—Continued

Item	Characteristic
Bandwidth (–3 dB)	At least 34 megahertz.
Maximum Input Voltage	500 volts dc plus peak ac, derated with frequency as follows: About 400 volts at 1 megahertz. About 47 volts at 10 megahertz. About 18 volts at 30 megahertz.
P6104	
Attenuation	10X.
Input Resistance	10 megohm.
Input Capacitance	Approximately 10.5 picofarad.
Bandwidth (–3 dB)	At least 100 megahertz.
Maximum Input Voltage	500 volts dc plus peak ac derated with frequency as follows: 30 volts at 50 megahertz. 27 volts at 100 megahertz.

Table 1-2. Environmental Characteristics

Item	Characteristic
Temperature	
Operating	–15° to +55° C (+5° to +131° F).
Storage	–62° to +85° C (–79.6° to +185° F).
Altitude	
Operating	To 15,000 feet. Maximum operating temperature decreases by 1° C per 1000 feet increase in altitude above 5000 feet.
Storage	To 50,000 feet.
Humidity (Operating and Storage)	Five cycles (120 hours to 95% relative humidity referenced to MIL-T-28800).
Vibration (Operating and Non-Operating)	Along each of the three major axes: a. Cycled 5 to 25 to 5 hertz for 10 minutes at 0.025 inches peak to peak. b. Cycled 25 to 55 to 25 hertz for 5 minutes at 0.020 inches peak to peak. c. Dwelled at 55 hertz for 10 minutes at 0.020 inches peak to peak.
Shock (Operating and Non-Operating)	30 g's, 1/2 sine, 11 milliseconds duration, 3 shocks each direction per axis for a total of 18 shocks.
Transit Drop (Non-Operating)	Drop unboxed instrument 8 inches on each corner and face for a total of 14 drops. Drop test performed on a rigid wooden surface.

Table 1-2. Environmental Characteristics—Continued

Item	Characteristic
Drip-Proof (Front cover on Non-Operating)	Spray from 3 feet above instrument with instrument tilted 15° away from the horizontal plane in each of 4 directions horizontal.
Bench Handling (Operating)	Edge lifts and drops on work bench on bottom and rear faces, total of 8 drops.

Table 1-3. Physical Characteristics

Item	Characteristic
Weight With Panel Cover, Modules, and Accessories	27.0 pounds (12.2 kilograms)
Without Panel Cover and Accessories	24.0 pounds (10.9 kilograms)
Height (With Feet)	7.05 inches (17.91 centimeters)
Width	
With Handle	13.65 inches (34.67 centimeters)
Without Handle	12.50 inches (31.75 centimeters)
Depth	
With Panel Cover	21.45 inches (54.48 centimeters)
Handle Extended	24.10 inches (61.21 centimeters)
Probe Length (P6101 and P6104)	39.37 inches (1 meter)
Transportation	Meets the limits of National Safe Transit Committee test procedure 1A with a 30 inch drop.
Construction	Plastic alloy cabinet, aluminum alloy chassis, and glass laminate circuit boards.
Finish	Anodized front panel and textured cabinet.

SECTION II

SPECIAL TOOLS AND TEST EQUIPMENT

2-1. SPECIAL TOOLS. No special tools are required.

2-2. TEST EQUIPMENT. Test equipment required to maintain the instrument is listed in Table 2-1. Equivalent items may be used if the recommended items are not available.

2-3. CONSUMABLE MATERIALS. Table 2-2 lists the consumable materials recommended for maintaining the instrument. Equivalent materials may be used if those recommended are not available.

Table 2-1. Test Equipment List

Tool/Equipment Number	Nomenclature	Application	Description
Tektronix PG 506 ¹	Calibration Generator and Fast-rise Pulse Generator	Vertical deflection system checks and adjustments; trigger range check; trigger view check and adjustment; high and low frequency compensation adjustments.	Range, 1 kilohertz and 100 kilohertz square-wave; output amplitude, 20 millivolts to 20 volts; accuracy, within 0.4%; fast-rise output risetime, 1 nanosecond or less.
Tektronix TG 501 ¹	Time-Mark Generator	Sweep timing checks and adjustments; Y-axis adjustments; geometry adjustments.	Marker range, 10 nanoseconds to 0.5 seconds; accuracy, within 0.4%.
Tektronix SG 502 ¹	Sine-wave Generator Low Frequency	Trigger checks.	Range, 30 hertz to 50 kilohertz; output amplitude, 10 millivolts to 4 volts peak to peak.
Tektronix SG 503 ¹	Sine-wave Generator	Bandwidth checks; cascade sensitivity checks; trigger checks and adjustments.	Range, 4 megahertz to 100 megahertz with a 50 kilohertz reference; accuracy, within 3%; output amplitude, 5 millivolts to 4 volts peak to peak.
Tektronix DM 501 ¹	Digital Multimeter	Power supply checks and adjustments; calibrator adjustments; crt bias adjustments; troubleshooting.	Range, -10 volts dc to +50 volts dc; 300 volts ac, 2 kilohm to 20 megohm; accuracy, within 0.1%.
AN/USM-425(V)1	Oscilloscope	Sweep gate output checks; calibrator output checks; Z-axis compensation adjustment and calibration checks; troubleshooting waveforms.	Bandwidth, at least 100 megahertz; vertical deflection factor, at least 5 millivolts/division; sweep rate, at least 2 microseconds/division.
Tektronix part 017-0061-00	CT-3 Signal Pickoff	Trigger checks.	Assembly, signal pickoff (CT-3).

Table 2-1. Test Equipment—Continued

Tool/Equipment Number	Nomenclature	Application	Description
Tektronix part 011-0049-01 (2 required)	Feedthrough Terminator	Test signal termination for performance checks and adjustments.	Termination, coaxial, 50 ohm, 2 watt, dc to 500 megahertz, BNC male to BNC female.
Tektronix part 067-0538-00	Input RC Normalizer	Vertical deflection system attenuator compensation adjustments.	Calibration fixture, 1 megohm with 20 picofarad input RC time constant, BNC male to BNC female.
Tektronix part 012-0057-01 (2 required)	Coaxial Cable with BNC Male Connectors	Test signal interconnections.	Cable assembly, RF, 50 ohm, 43 inches, BNC male to BNC male.
Tektronix part 067-0525-00 (2 required)	Dual Input Coupler	Matched dual test signal inputs.	Calibration fixture, BNC female input to dual BNC male output with RG-58C/U cable matched within 0.1 inch.
Tektronix part 103-0030-00	T Connector	Test signal interconnections	Adapter, connector, BNC, Tee, BNC male to two BNC female, type UG-274B/U.
Tektronix part 017-0063-00 Manufacturers part 0874-9700.	Adapter, GR874 to BNC female	Test signal interconnections.	Adapter, connector, BNC female to GR.
Tektronix part 017-0064-00. Manufacturers part 874QBPA	Adapter, GR874 to BNC male	Test signal interconnections.	Adapter, connector, BNC male to GR.
Tektronix part 011-0059-02	Attenuator, 10X, 50 ohm	Test signal interconnections.	Attenuator, 50 ohm, 2 watt, dc to 2 gigahertz, BNC female to BNC male.
Tektronix part 010-0277-00	Probe, high voltage	Used with DM 501 for power supply checks and troubleshooting	Voltage range, 1 kilovolt to at least 4 kilovolts.

¹ Requires a TM 500 series mainframe/power module.

Table 2-2. Consumable Materials List

Nomenclature	Material	Specification Number	Part Number
Grease, insulation	Silicone compound	MIL-S-8660B	NSN6850-00-880-7616
Lubricant	Silicone compound	MIL-S-8660B	NSN6850-00-880-7616
Mild detergent			NSN6850-00-570-9360-or part GC8666 (vender code 80112)
Contact cleaner	Isopropyl alcohol or freon	MIL-C-81302	NSN6850-00-105-3084

2-4. RACKMOUNTING ACCESSORY. Some instruments may be used in applications where rack mounting is useful. A 465M/USM-425(V)1 Rack Adapter

(Cradle Mount) kit is available as Tektronix part 040-0825-00. Installation instructions are provided with the kit.

SECTION III

PREPARATION FOR USE AND SHIPMENT

3.1 PREPARATION FOR USE

WARNING

Read the Safety Summary page in the front part of this manual before using the instrument.

a. Unpacking the Instrument. No special unpacking procedures are required.

b. Initial Inspection. This instrument was inspected and adjusted before shipment. Upon receipt, inspect for physical damage and missing accessories. The accessories, which are shown in Figure 8-2 are stored in the front cover.

c. Faceplate Filter Installation. The instrument was shipped with either a clear filter (faceplate protector) or blue filter installed. The blue filter is used to reduce light reflections and increase display contrast under high ambient light conditions. To exchange the filters refer to Figure 3-1.

d. Carrying Handle Positioning. The instrument handle can be positioned for carrying or as a tilt stand. There are several detent positions provided for convenient carrying or viewing. The instrument may also be set on its rear-panel feet for operation or storage. To position the handle (see CAUTION below), press in at both pivot points (see Figure 3-2) and position the handle to the desired position, then release the pivot points.

CAUTION

When positioning the handle as a tilt stand, be sure it is locked into a detent before letting the handle support the instrument. Otherwise, the tilt stand may collapse causing instrument damage.

e. Operating Voltage Selection. The instrument will operate from either a 116 volt ac or 232 volt ac nominal line voltage source with ranges as indicated on the rear

panel. Source selection is made with the LINE RANGE Selector on the rear panel (see Figure 3-3).

CAUTION

This instrument may be damaged if operated with the LINE RANGE Selector set to the incorrect position.

Before operating the instrument, perform the following line range selection and fuse verification procedures:

WARNING

To prevent electrical shock hazards when changing line voltage ranges or checking fuses, disconnect the power cord from the power source.

a. Disconnect the instrument from the power source.

b. Using a small blade screwdriver or other small blunt item (similar to a dull pencil), slide the LINE RANGE Selector up or down to the desired position (see Figure 3-3).

c. Change the line cord plug to match the power source receptacle or use a 116 to 232 volt adapter.

d. Change the line fuse to the correct value indicated on the rear panel adjacent to the fuse holder (see Figure 3-3).

f. Power Cord Information. This instrument has a detachable three wire power cord with a polarized plug for connection to the power source. The grounding terminal is directly connected to the instrument chassis. When not being used, the power cord may be removed and placed in the front cover.

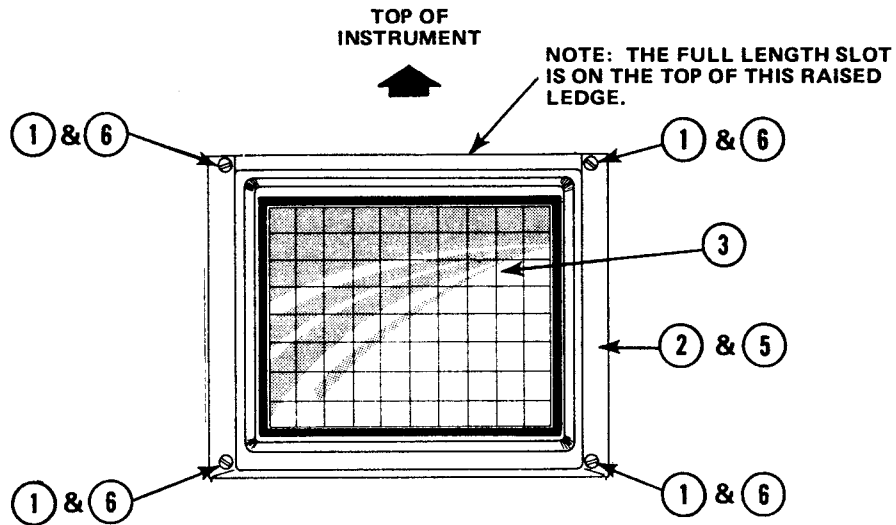

REMOVAL INSTRUCTIONS

- ① UNSCREW FOUR CORNER THUMBSCREWS (DO NOT UNSCREW COMPLETELY OUT OF PLASTIC IMPLOSION RETAINER).
- ② PULL IMPLOSION RETAINER WITH FILTER FORWARD AWAY FROM CRT FACEPLATE.
- ③ REMOVE FILTER BY LIFTING IT OUT OF THE IMPLOSION RETAINER.

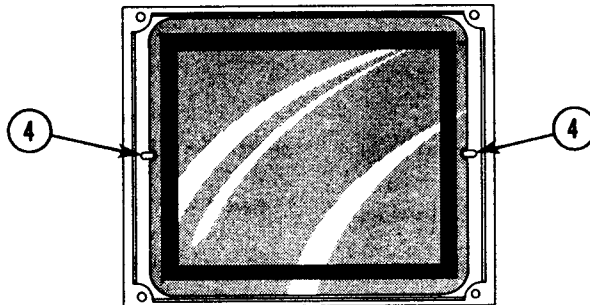

INSTALLATION INSTRUCTIONS

- ④ INSTALL FILTER IN NOTCHES ON IMPLOSION RETAINER WITH THE BLACK MASK TOWARD THE CRT.
- ⑤ POSITION IMPLOSION RETAINER ON CRT FACEPLATE SO FULL LENGTH SLOT IS TOWARD THE TOP OF THE INSTRUMENT.
- ⑥ SCREW IN THE FOUR CORNER THUMBSCREWS.

Figure 3-1. Removal and installation of faceplate filters.

PRESS IN ON PIVOT POINTS
BOTH SIDES TO POSITION
CARRYING HANDLE

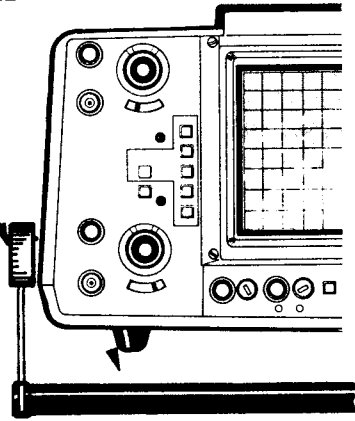

Figure 3-2. Carrying handle positioning.

WARNING

This instrument is intended to be operated from a single phase power source. Operation from other power sources such as phase-to-phase on a three wire system is not recommended.

3-2. OPERATING TEMPERATURE. This instrument is cooled by natural convection; therefore, adequate clearance (at least one inch) should be maintained around the case. The clearance provided by the feet on the rear panel must be maintained to prevent power supply overheating. A thermal cutout inside the instrument provides overheating protection and disconnects power if the internal temperature exceeds a safe operating level. Power is automatically restored when the internal temperature returns to a safe operating level.

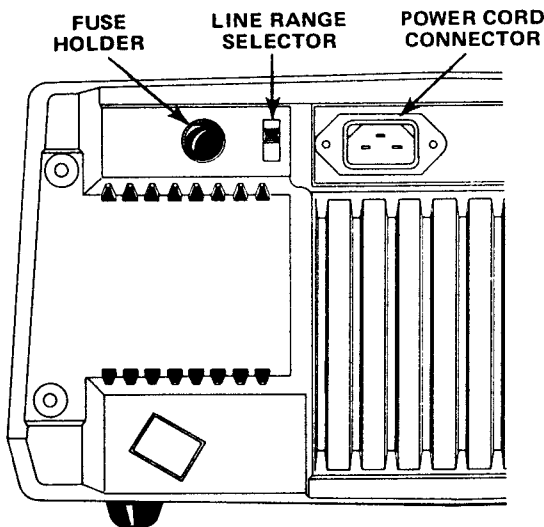

Figure 3-3. Power section of rear panel.

CAUTION

To prevent damage to the instrument when it continually shuts down due to overheating, it should be turned-off and referred to maintenance personnel.

3-3. PREPARATION FOR SHIPMENT. For shipment of the instrument, refer to the current edition of MIL-P-116 and MIL-STD-794 for preservation and packaging instructions and methods.

SECTION IV

OPERATION INSTRUCTIONS

4-1. THEORY OF OPERATION. The following discussion describes the operation of the oscilloscope circuitry. First a general description of the overall relationship between the basic circuits is given. Then each circuit is described in detail.

4-2. BASIC CIRCUIT FUNCTIONS. The overall relationship between the basic circuits is described below. Refer to the basic block diagram shown in Figure 4-1 to aid in understanding the discussion.

a. Vertical Module. The Vertical Module contains the CH 1 and CH 2 Input, CH 1 and CH 2 Preampifier and Vertical Switching Hybrid Integrated Circuit, Vertical Switching Control Circuit, Delay Line Driver and Delay Line, and the Vertical Amplifier (see Figure 4-1).

(1) CH 1 and CH 2 Input. The Input circuits provide input coupling and attenuation for the signals connected to the CH 1 and CH 2 input connectors. AC, DC, and GND coupling modes are provided. Two attenuators in each channel provides attenuation factors of 10:1, 100:1, or when switched in series 1000:1.

(2) CH 1 and CH 2 Preampifier and Vertical Switching. U4160 is a hybrid integrated circuit which contains the Vertical Switching circuitry and both the CH 1 and CH 2 Preampifiers.

(a) The signal from the vertical input attenuators is applied to U4160, amplified, and supplied to the Delay Line Driver. In conjunction with the input attenuators, the gain of the preampifiers is changed to provide the deflection factors indicated by the VOLTS/DIV switches. A sample of the signals present in the amplifiers is supplied to the Trigger Switching and Trigger Input Amplifiers in the Horizontal Module.

(b) The Vertical Switching circuitry selects which preampifier will supply the signal to the Delay Line Driver.

(3). Vertical Switching Control. Inputs to this circuit are from the VERT MODE switch and from the Sweep Control circuit (alternate sync pulse). The output is supplied to U4160 to control Vertical Switching.

(4) Delay Line Driver and Delay Line. The vertical signal from the CH 1 and CH 2 Preampifiers is amplified by the Delay Line Driver and supplied to the Delay Line. The Delay Line delays the vertical signal enough so the portion of the vertical signal initiating the sweep can be viewed.

(5) Vertical Amplifier. This circuit amplifies the signal from the Delay Line. The amplified signal is used to drive the vertical deflection plates of the crt.

b. Horizontal Module. The Horizontal Module contains Trigger Input Amplifiers and Trigger Switching, A Trigger Generator, B Trigger Generator, A Sweep Generator, B Sweep Generator, Horizontal Preampifier, +A GATE OUT Amplifier, +B GATE Buffer, and Sweep Control (see Figure 4-1).

(1) Trigger Input Amplifiers and Trigger Switching. The Trigger Input Amplifiers are buffer amplifiers between the Trigger Generators and the source of the trigger signal. Trigger Switching selects the source of the signal used to trigger the Sweep Generator(s) and selects the method of coupling this signal to the Trigger Generator(s).

(2) A Trigger Generator. Using a signal selected by the A TRIGGER SOURCE switch, the A Trigger Generator produces a pulse which causes the A Sweep Generator to produce an A sweep ramp.

(3) B Trigger Generator. Using a signal selected by the B TRIGGER SOURCE switch, the B Trigger Generator produces a pulse which causes the B Sweep Generator to produce a B sweep ramp.

(4) A Sweep Generator. The A Sweep Generator, when initiated by the A Trigger Generator, produces a linear sawtooth output signal. The slope of the sawtooth is controlled by the A TIME/DIV switch.

(5) B Sweep Generator. The B Sweep Generator is basically the same as the A Sweep Generator. However, it produces a sawtooth output signal only after a delay time selected by the A TIME/DIV switch and the DELAY TIME POS control. When the B TRIGGER SOURCE switch is in the STARTS AFTER DELAY position, the B Sweep Generator begins to produce a sawtooth immediately following the selected delay time. In the other positions of the B TRIGGER SOURCE switch, the B Sweep Generator does not produce a sawtooth until it receives a trigger pulse occurring after the selected delay time.

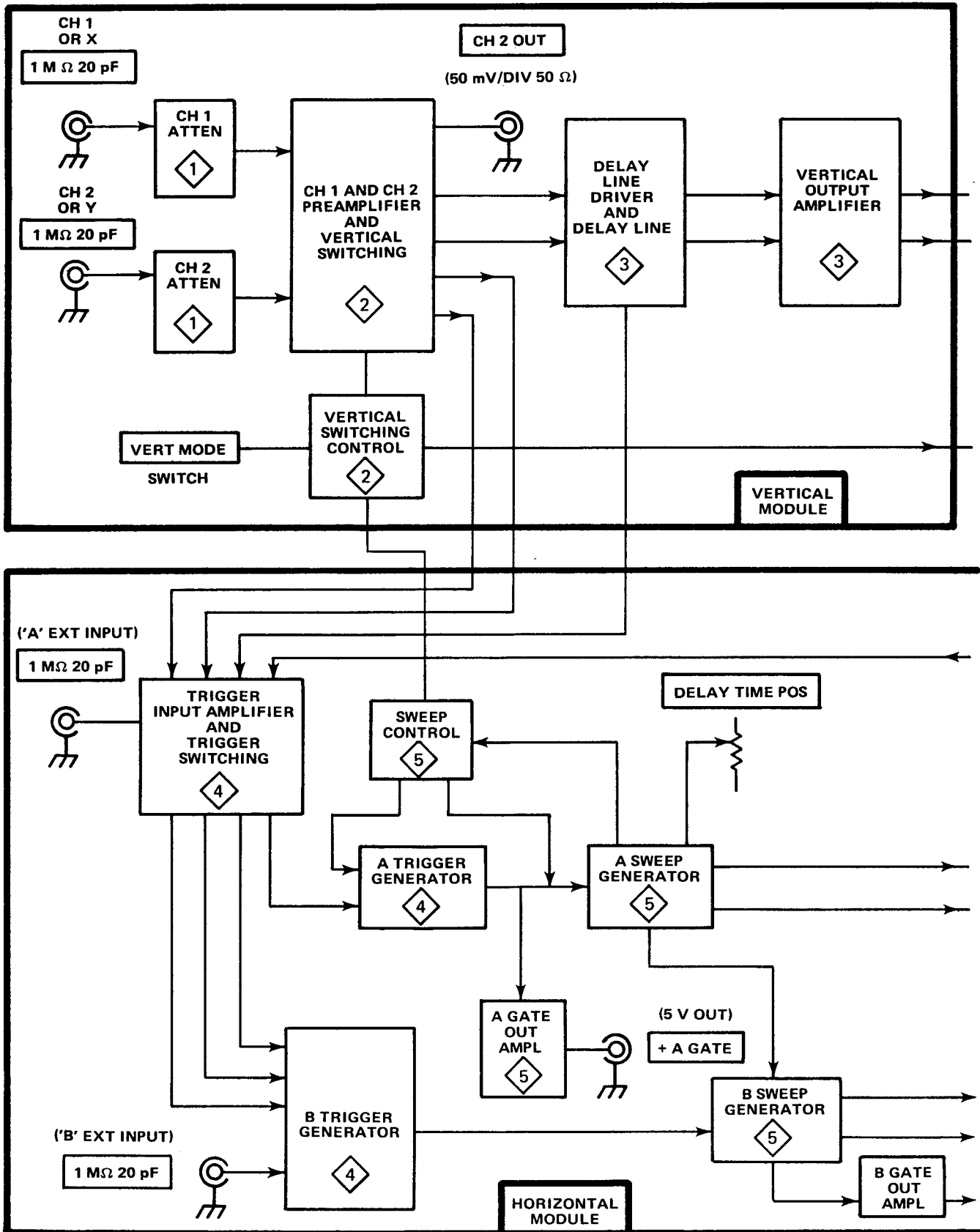

Figure 4-1. Overall block diagram (sheet 1 of 2).

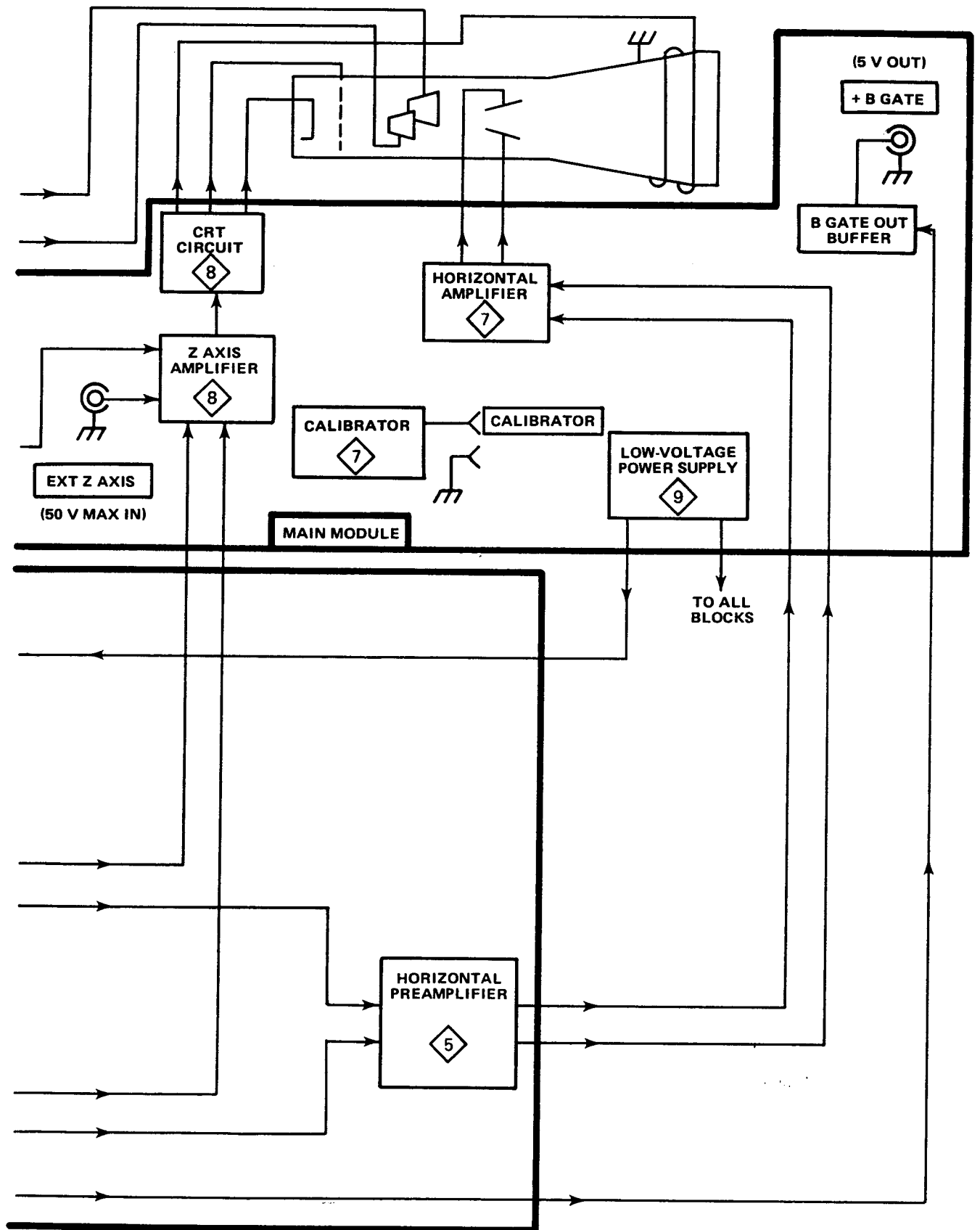

Figure 4-1. Overall block diagram (sheet 2 of 2).

(6) **Horizontal Preamplifier.** This circuit amplifies the output of the A or B Sweep Generator. The amplified sweep ramp is supplied to the Horizontal Amplifier in the Horizontal Module. In the X10 position of the X10 MAG switch, the gain of the Horizontal Preamplifier is increased by a factor of ten which increases the displayed sweep rate by a factor of ten. In the X-Y position of the TIME/DIV switches, the signal from the CH 1 Preamplifier is connected to the Horizontal Preamplifier and provides horizontal deflection.

(7) **+A GATE OUT Amplifier.** This circuit samples the A sweep start gate and produces a positive-going rectangular pulse coincident with A sweep time.

(8) **+B GATE OUT Buffer.** This circuit sums the B sweep holdoff signal from U2690, the delayed gate, and the B sweep gate, and produces an output signal coincident with B sweep time. This output is supplied to the +B GATE OUT Amplifier in the Main Module.

(9) **Sweep Control.** The Sweep Control circuitry is contained in an integrated circuit. This circuitry controls A Sweep holdoff time and A Trigger mode, and supplies the alternate sync pulse to the Vertical Switching Control circuit.

c. Main Module. The Main Module contains the Z Axis Amplifier, Crt Circuit, Horizontal Amplifier, Calibrator, and Low Voltage Power Supply.

(1) **Z-Axis Amplifier.** This circuit amplifies the unblanking signals supplied by the Vertical Switching Control circuit, the A Sweep Generator, and the B Sweep Generator. The output controls the brightness of the display through the Crt Circuit.

(2) **Crt Circuit.** This circuit provides the high voltages needed for operation of the crt.

(3) **Horizontal Amplifier.** This circuit amplifies the sweep ramp signal supplied by the Horizontal Preamplifier in the Horizontal Module. The output of the Horizontal Amplifier drives the horizontal deflection plates of the crt.

(4) **+B GATE OUT Amplifier.** This circuit amplifies the signal from the +B GATE OUT Buffer in the Horizontal Module. The amplified signal is supplied to an externally accessible BNC connector. The output signal is a positive-going rectangular pulse coincident with B Sweep time.

(5) **Calibrator.** The Calibrator provides an externally accessible square-wave output with an accurate voltage amplitude. This signal is used for checking vertical deflection accuracy and probe compensation.

(6) **Low Voltage Power Supply.** The Low Voltage Power Supply provides the low voltages needed to operate the oscilloscope. The high voltages are supplied by the Crt Circuit.

4-3. DETAILED CIRCUIT OPERATION. The following detailed circuit description is subdivided according to the overall block diagram shown in Figure 4-1. Simplified diagrams are used, where needed, for clarity. Complete schematic diagrams are located in Section VI.

a. Vertical Module.

(1) **CH 1 and CH 2 Input.** The CH 1 and CH 2 Input circuits are shown in Figure FO-2. These circuits contain the input coupling switches, the vertical attenuators, and input source followers. Both circuits are the same so only the CH 1 circuit will be discussed.

(a) **Input Coupling Switches.** S4100A selects the method of coupling the input signal to the attenuators.

1 In the DC position of S4100A, the input signal is connected directly to the attenuators.

2 In the AC position of S4100A, the input signal passes through C4102 and then to the attenuators. This blocks the dc component of the input signal.

3 In the GND position of S4100A, the gate of the input source follower (Q4124A) is connected to ground through R4103. Since the resistance of R4103 is so small compared to that of R4102, the percentage of the input signal passed to the gate of Q4124A is negligible. This essentially disconnects the input signal from Q4124A and provides a 0 volt reference display. Also, in the GND position of S4100A, C4102 charges to the average dc level of the input signal through R4102 and R4103. This prevents coupling a high-amplitude transient to Q4124A when S4100A is switched from GND to AC.

(b) **Vertical Attenuators.** To obtain the vertical deflection factors indicated by the VOLTS/DIV control, the input signal is attenuated and the gain of the Vertical Preamplifier is reduced (see 4-3. a. (2) (a) 1). The attenuators are frequency-compensated voltage dividers. The attenuators provided are a divide by ten and a divide by one hundred. To obtain divide by 1000, the two attenuators are connected in series. Table 4-1 shows the VOLTS/DIV settings and the attenuation and gain switching required to obtain them.

Table 4-1. Attenuation and Gain Switching Sequence

VOLTS/DIV SETTING	ATTENUATION	GAIN REDUCTION
5 mV	1X	1X
10 mV	1X	2X
20 mV	1X	4X
50 mV	10X	1X
100 mV	10X	2X
200 mV	10X	4X
500 mV	100X	1X
1V	100X	2X
2 V	100X	4X
5 V	1000X	1X

(c) **Input Source Followers.** The signal from the CH 1 attenuator is connected to the gate of Q4124A. The one megohm input impedance seen at J4100 is determined by R4122. To prevent damage to Q4124A in the presence of high-amplitude positive-going input signals, R4123 limits gate current. In the presence of high-amplitude negative-going input signals, CR4124 clamps the gate of Q4124A to about -5.7 volts and R4123 limits the current through CR4124. FET Q4124B provides a relatively constant current source for Q4124A.

(2) **CH 1 and CH 2 Preamp and Vertical Switching.** A schematic diagram of this circuit is shown in Figure FO-3. The preamplifier and switching circuits are both contained in one hybrid integrated circuit (U4160). The preamplifier circuits provide the initial stages of amplification for the vertical input signals. The switching circuit determines which of the vertical input signals will be displayed on the crt.

(a) **CH 1 and CH 2 Preamp.** The single-ended signals from the input source followers are connected to terminals 1 and 32, respectively of U4160. The single-ended input signals are converted to paraphase signals and internally connected to the Vertical Switching circuit.

1 **Gain Switching.** To provide the vertical deflection factors indicated by the VOLTS/DIV control, the gains of the preamplifiers are reduced and attenuators are switched into the signal path, see 4-3. a. (1) (b). The CH 1 gain setting resistors are connected from terminals 4 and 6 to terminals 7 and 8 of U4160. The CH 2 gain setting resistors are connected from terminals 29 and 31 to terminals 26 and 27 of U4160. The VOLTS/DIV switches determine which gain setting resistors are used. Table 4-1 shows the VOLTS/DIV settings and the attenuation and gain switching needed to obtain them.

2 **CH 2 INVERT.** The CH 2 signal can be inverted as displayed on the crt. This is done by inverting the

signal in the CH 2 Preamp. The polarity of the CH 2 signal is determined by the dc voltage on terminals 34 and 36 of U4160. With 0.8 volts on terminal 34 and 0.0 volts on terminal 36, the CH 2 signal is not inverted. To invert the signal, the INVERT switch (S4240) is pushed, which sets terminal 34 to 0.0 volts and terminal 36 to 0.8 volts.

(b) **Vertical Switching.** Transistor gates within U4160 allow either the CH 1 or CH 2 signal to be connected to the output of U4160 (terminals 17 and 18). The transistor gates are controlled by the Vertical Switching Control circuit. Figure 4-2 shows a simplified diagram of the transistor gates and the Vertical Switching Control circuit. Figure 4-2 shows the signal path with the VERT MODE switch set to CH 1.

(c) **CH 1 and CH 2 Trigger Pickoff.** U4160 supplies samples of the signals present in the CH 1 and CH 2 Preamp circuits. The CH 1 trigger signal output is at terminal 13 of U4160 and the CH 2 trigger signal output is at terminal 22 of U4160.

(d) **CH 2 OUT Signal Pickoff.** Terminal 21 of U4160 supplies a sample of the signal present in the CH 2 Preamp to the base of Q4282. This signal is amplified through Q4282 and Q4288, then connected to the CH 2 OUT connector (J4289).

(e) **X-Axis Signal Pickoff.** A sample of the signal present in the CH 1 Preamp is supplied to terminal 14 of U4160. In the X-Y horizontal mode, this signal is connected to the Horizontal Preamp in the Horizontal Module and provides horizontal deflection for the crt.

(3) **Vertical Switching Control.** Figure FO-3 shows the schematic diagram which contains the Vertical Switching Control circuitry. Transistor gates within U4160 determine which of the signals in the CH 1 and CH 2 Preamp is supplied to the output of U4160 (terminals 17 and 18). The CH 1 gate is controlled by the voltages on terminals 15 and 16 of U4160. The CH 2 gates are controlled by the voltages on terminals 19 and 20 of U4160. These voltages are controlled by the channel switching multivibrator and the VERT MODE switch.

(a) **Channel Switching Multivibrator.** The channel switching multivibrator consists of Q4316 and Q4326. The multivibrator operates in the CHOP and ALT settings of the VERT MODE switch. In the CHOP mode, the multivibrator is free running at about 250 kilohertz. In the ALT mode it switches states when triggered by the alternate trace sync pulse through Q4334.

(b) **CH 1 Vertical Mode.** When the VERT MODE switch is set to CH 1, -5 volts is connected to R4323 through the VERT MODE switch S4330. Resistors R4323 and R4322 form a divider which sets terminals 16 and 19

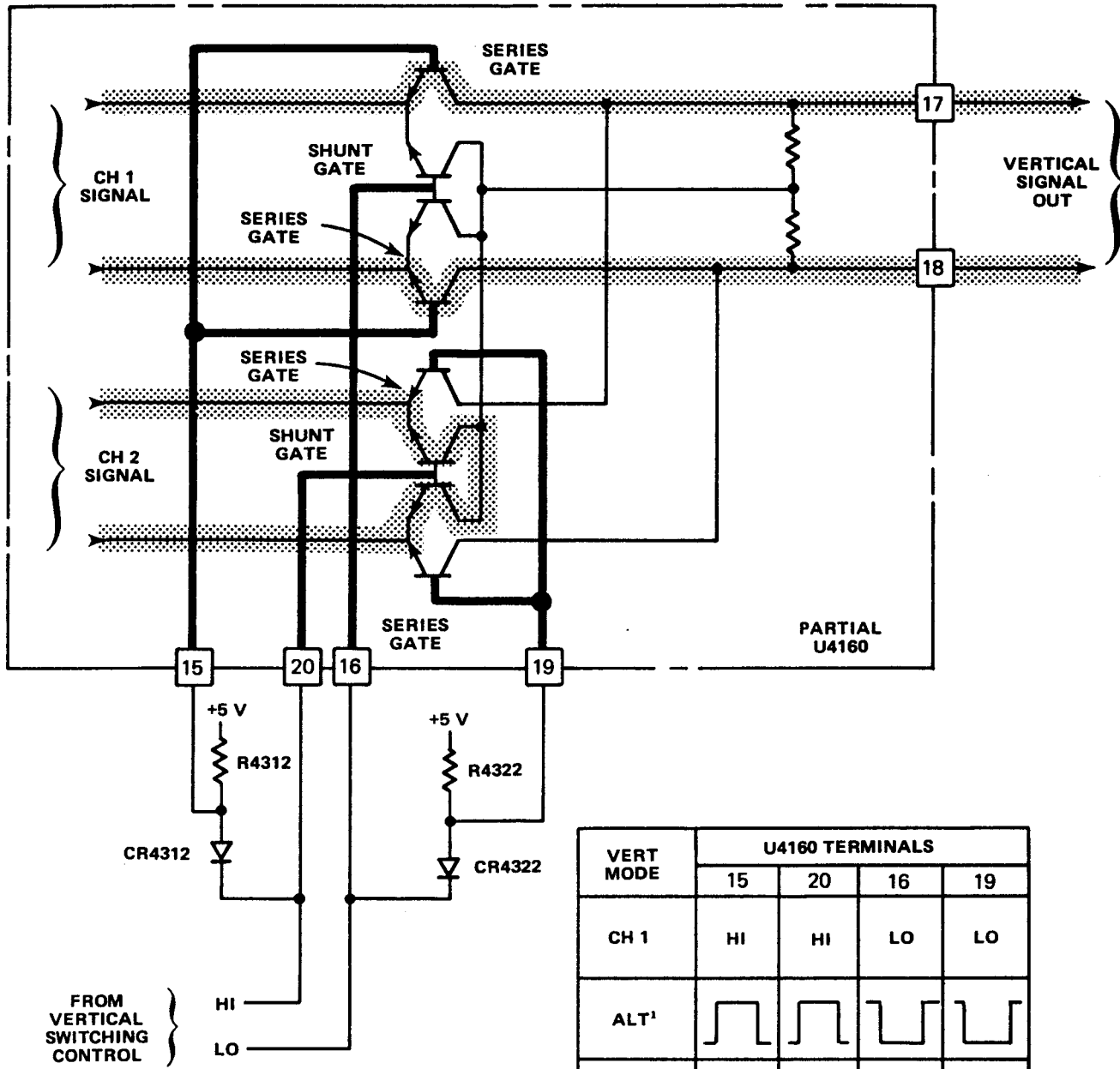

VERT MODE	U4160 TERMINALS			
	15	20	16	19
CH 1	HI	HI	LO	LO
ALT ¹				
ADD	HI	LO	HI	LO
CHOP ²				
CH 2	LO	LO	HI	HI

¹ CHANGES STATES AT THE END OF EACH SWEEP.
² REPETITION RATE ABOUT 250 kHz.

Figure 4-2. Channel switching gates.

of U4160 LO. Terminals 15 and 20 of R4160 are pulled HI through R4312. This turns off the CH 2 series gate and turns on the CH 1 series gate. The CH 1 signal passes to terminals 17 and 18 of U4160.

(c) CH 2 Vertical Mode. This mode works the same as the CH 1 mode except -5 volts is connected to R4313 setting terminals 15 and 20 LO and terminals 16 and 19 are pulled HI through R4322. This turns on the CH 2 series gate and allows the CH 2 signal to pass to terminals 17 and 18 of U4160.

(d) Add Vertical Mode.

1 In the ADD mode the algebraic sum of the output signals from the CH 1 and CH 2 Preamplifiers is supplied to terminals 17 and 18 of U4160.

2 When the VERT MODE switch (S4330) is set to ADD, neither R4313 nor R4323 are connected to -5 volts. This allows terminals 15 and 19 to be pulled HI through R4312 and R4322 respectively. Terminal 20 is also pulled positive through R4312 but, because of CR4312, terminal 20 is LO with respect to terminal 15. In the same way, terminal 16 is LO with respect to terminal 19 due to CR4322. This turns on both the CH 1 and CH 2 series gates and turns off both shunt gates (see Figure 4-2). Both signals pass to terminals 17 and 18 of U4160.

(e) ALT Vertical Mode. In the ALT mode the channel switching multivibrator operates as a bistable multivibrator. The state of the multivibrator is switched at the end of each sweep. The CH 1 and CH 2 signals are individually displayed on alternate sweeps.

1 When the VERT MODE switch is set to ALT, -5 volts is connected to the emitter of Q4334 through R4333. The base of Q4334 is pulled positive with respect to its emitter through R4334. This turns on Q4334 and provides the negative supply voltage for the multivibrator.

2 When Q4334 turns on, either Q4316 or Q4326 will turn on. Assume Q4316 turns on. This pulls terminals 15 and 20 of U4160 LO. Terminals 16 and 19 are pulled HI through R4322. This blocks the CH 1 signal and passes the CH 2 signal to terminals 17 and 18 of U4160.

3 While Q4316 is on, the end of C4316 connected to the emitter of Q4316 charges positive with respect to the end connected to the emitter of Q4326.

4 At the end of each sweep, the Sweep Control circuit in the Horizontal Module supplies a negative-going pulse to the base of Q4334. This momentarily turns off Q4334 removing the negative supply voltage from the multivibrator. Neither Q4316 nor Q4326 can conduct.

5 We previously assumed Q4316 was on and had charged the end of C4316 connected to the emitter of Q4316 positive with respect to its other end. When Q4334 again turns on, the emitter of Q4326 will be more negative than the emitter of Q4316. Therefore Q4326 will turn on, reversing the previously assumed condition. Terminals 16 and 19 of U4160 will be pulled LO through Q4326 and terminals 15 and 20 will be pulled HI through R4312. The CH 2 signal will be blocked and the CH 1 signal will pass to terminals 17 and 18 of U4160.

(f) CHOP Vertical Mode. In the CHOP mode the channel switching multivibrator operates as an astable multivibrator. The CH 1 and CH 2 signals are alternately displayed during the same sweep. The switching transients are blanked and cannot be seen.

1 When the VERT MODE switch is set to CHOP, -5 volts is connected to the emitters of Q4316 and Q4326 through R4318 and R4328, respectively. This provides the negative supply voltage for the channel switching multivibrator. The multivibrator operates as an astable multivibrator with a repetition rate of about 250 kilohertz. Transistors Q4316 and Q4326 conduct alternately to switch the CH 1 and CH 2 transistor gates in the same manner as for the ALT setting of the VERT MODE switch.

2 The frequency determining components are C4316, R4318, and R4328.

3 The chop blanking amplifier (Q4338) provides an output pulse to the Z Axis Amplifier to blank the switching transients. During the time the multivibrator is switching, the current change in the primary of T4335 induces a voltage in the secondary. This induced voltage drives the base of Q4338 negative which turns it off. The resulting positive-going pulse on the collector of Q4338 is supplied to the Z Axis Amplifier in the Main Module. The length of this pulse is determined by R4335 and C4335.

(4) Delay Line Driver and Delay Line. Figure FO-3 and Figure FO-4 show the Delay Line Driver and Delay Line circuitry. The Delay Line Driver buffers the vertical signal from terminals 17 and 18 of U4160 and supplies it to the Delay Line. The Delay Line delays the vertical signal about 120 nanoseconds. The Delay Line Driver and Delay Line circuitry also contains the NORM trigger signal pick-off, the BW LIMIT 20 MHz switch, and the TRIG VIEW switch.

(a) Delay Line Driver. The output from the channel switching gates, at terminals 17 and 18 of U4160, is applied to the Delay Line Driver (Q4342, Q4352, Q4362, and Q4372). Transistors Q4342 and Q4352 buffer the output of U4160 to provide optimum frequency response. Transistors Q4362 and Q4372 are connected as feedback

Operation Instructions

amplifiers with R4362 and R4372 providing feedback. Resistors R4365 and R4375 provide reverse termination for the Delay Line.

(b) **NORM Trigger Signal Pickoff.** A sample of the signal present in the Delay Line Driver is supplied to the base of emitter follower Q4384. The signal on the emitter of Q4384 is supplied to the Trigger Switching circuit in the Horizontal Module. This signal is used to trigger the sweep on the signal providing vertical deflection regardless of the setting of the VERT MODE switch.

(c) **BW LIMIT 20 MHz Switch.** When the BW LIMIT 20 MHz switch (S4380) is pulled, a low-pass filter is placed in the vertical path between the Delay Line Driver and the Delay Line. The filter components are C4388, C4389, L4378, and L4388. The inductors are in series with the signal path blocking high frequencies and the capacitors are in parallel with the signal path shunting high frequencies. This limits the upper -3 dB point of the vertical system to 20 megahertz.

(d) **TRIG VIEW Switch.** When the TRIG VIEW switch (S4380) is pushed in and held, the vertical signal is disconnected from the Delay Line input and a sample of the signal being applied to A Trigger Generator is applied in its place. This allows viewing the signal being applied to the A Trigger Generator at the time the sweep is triggered. This is useful when using an external source for triggering (in the EXT and EXT \div 10 positions of the A SOURCE switch).

(e) **Delay Line.** The Delay Line (DL4400) provides about 120 nanoseconds of signal delay. The delay allows the Trigger Generator to initiate sweep generation before the vertical signal reaches the crt. This allows viewing the portion of the vertical input signal at which the sweep is triggered.

(5) **Vertical Amplifier.** The Vertical Amplifier amplifies the signal from the output of the Delay Line to a level sufficient to drive the vertical deflection plates of the crt.

(a) The Vertical Amplifier is a two-stage cascode amplifier. The first stage consists of Q4421, Q4429, Q4431, and Q4439. The second stage consists of Q4447, Q4463, Q4457, and Q4473. A cascode amplifier consists of a common-emitter amplifier driving a common-base amplifier.

(b) The series RC networks between the emitters of Q4421 and Q4431 in the first stage provide high-frequency compensation. Thermistor RT4419 and varactors CR4416 and CR4417 correct for changes in high-frequency compensation as temperature changes.

(c) As temperature increases the gain of an amplifier of this type decreases. To compensate for this, the resistance of thermistor RT4416 decreases as temperature increases. This reduces the emitter resistance of Q4421 and Q4431. The decreased emitter resistance decreases the negative feedback due to the emitter resistance and holds the gain constant as temperature increases.

(d) Overall gain of the Vertical Amplifier is adjusted by R4443. Adjusting R4443 changes the collector load resistance on Q4429 and Q4439.

(e) Part of the BEAMFINDER switch (S500) is located in the Vertical Amplifier.

1 When S500 is not pushed, the junction of R4427 and R4437 is directly connected to +5 volts through S500. Resistors R4427 and R4437 supply current to Q4429 and Q4439.

2 When S500 is pushed, it removes +5 volts from the junction of R4427 and R4437. Now +5 volts is supplied to the junction of R4427 and R4437 through R4425. The increased resistance reduces the current supplied to Q4429 and R4439 reducing their dynamic range. The reduced dynamic range prevents Q4429 and Q4439 from passing any vertical signals which would cause an off-screen display. The resulting vertical display is compressed and always appears on the crt regardless of the amplitude of the input signal or the setting of the vertical POSITION control.

b. Horizontal Module.

(1) **Trigger Input Amplifiers and Trigger Switching.** Figure FO-5 shows a schematic diagram of this circuit. The Trigger Input Amplifier buffers the trigger signal. The Trigger Switching circuit selects the source of the trigger signal and the method of coupling the trigger signal to the Trigger Generator.

(a) **CH 1 and CH 2 Trigger Input Amplifiers.** The CH 1 and CH 2 trigger signals are supplied by U4160 in the Vertical Module. The signals pass through emitter followers Q4142 and Q4122. The outputs of the emitter followers are supplied to the SOURCE switches.

(b) **NORM Trigger Input Amplifier.** The NORM trigger signal is picked off the Delay Line Driver circuit. Emitter follower Q4384, in the Delay Line Driver circuit, buffers the signal and supplies it to the SOURCE switches.

(c) EXT Trigger Input Amplifier.

1 The A EXT Trigger Input Amplifier consists of Q2212, Q2214, and Q2216. The B EXT Trigger Input Amplifier consists of Q2112, Q2114, and Q2116. Both amplifiers are the same so only the A EXT Trigger Input Amplifier will be discussed.

2 The A EXT trigger signal is applied to J2205. The signal passes through one of two voltage dividers. The A SOURCE switch (S2200) determines which divider is selected. In the EXT position, the A SOURCE switch selects the divider composed of R2205-C2205 and R2206-C2206. In the EXT position the selected divider attenuates the input signal by a factor of about 4. In the EXT ÷ 10 position, the A SOURCE selects the divider composed of R2203-C2203 and R2204-C2204. In the EXT ÷ 10 position the selected divider attenuates the input signal by a factor of about 40. The capacitors in parallel with the divider resistors provide correct voltage divider action at high frequencies.

3 In the AC, LF REJ, and HF REJ positions of the A COUPLING switch (S2220), the signal from the output of the selected voltage divider is coupled to the gate of Q2212 through a capacitor (C2212). In the DC position, the signal is directly connected to the gate of Q2212.

4 The EXT signal is applied to the gate of source-follower Q2212. FET Q2214 provides a relatively-constant current source for Q2212. Diode CR2214 compensates for current changes as temperature changes by slightly adjusting the bias on Q2214. The signal on the source of Q2212 is applied to the base of emitter follower Q2216. The signal on the emitter of Q2216 is supplied to the A SOURCE switch.

5 To protect Q2212 in the presence of high-amplitude positive-going input signals, R2203 or R2205 (depending on the A SOURCE setting) limits the gate current that can be drawn by Q2212. In the presence of high-amplitude negative-going signals, CR2213 becomes forward biased. The path for current flow is from -5 volts through R2229, CR2213, and R2204 or R2205. Resistor R2203 or R2205 limits the current through R2229 and CR2213 preventing the anode of CR2213 from going more negative than about -6 volts.

(d) Trigger Switching. Trigger SOURCE Switching selects the source of the signal applied to the Trigger Generators. Trigger COUPLING Switching determines the band of frequencies supplied to the Trigger Generators. The A and B Trigger Switching circuits are the same except A SOURCE has a LINE position and B SOURCE has a STARTS AFTER DELAY position. The LINE position supplies a sample of the power line voltage from the Low-Voltage Power Supply to the A Trigger Generator. The STARTS AFTER DELAY position will be discussed in the B Trigger Generator description. Since both circuits are so similar, only the A Trigger Switching circuit will be discussed.

1 Two paths exist for the triggering signal. The high-frequency signal components connect directly to input pins of U2260. The low-frequency signal components connect to pin 19 of U2260 through the A SOURCE switch.

Figure 4-3A shows a simplified diagram of the low-frequency signal path. Figure 4-3B shows a simplified diagram of the high-frequency signal path.

2 Figure 4-4 shows a simplified diagram of signal flow with A SOURCE set to NORM and A COUPLING set to AC. Other SOURCE settings operate in a similar manner. Each of the high-frequency signal inputs to U2260 is internally connected to the base of an emitter follower. Normally these emitter followers are prevented from conducting by connecting the base to -2 volts through a pair of resistors (see Figure 4-4). To select a high-frequency input, the junction of these resistors is connected to ground through the SOURCE switch which allows the emitter in U2260 to conduct. For instance, to select the NORM trigger source, the junction of R2233 and R2238 is grounded through the A SOURCE switch (see Figure 4-4).

3 For all A COUPLING settings except HF REJ, the resistor junction selected is connected to ground through the A COUPLING switch (see Figure 4-3B and Figure 4-4). In the HF REJ position, the selected resistor junction is disconnected from ground and pin 4 of U2260 is selected by grounding the junction of R2243 and R2242. Pin 4 must be selected even though no signal is connected to it because one of the emitter followers within U2260 must be selected for proper operation of U2260. Since the high-frequency signal path is opened the only signal supplied to the A Trigger Generator is through the low-frequency path.

4 For the AC and HF REJ positions of the A COUPLING switch, the low-frequency signal is ac coupled through C2226 and C2227 to pin 19 of U2260. In the dc position, the low-frequency signal is dc coupled (C2226 and C2227 are bypassed). In the LF REJ position, the low-frequency signal is interrupted and only the high-frequency signal is connected to the A Trigger Generator.

(2) A Trigger Generator. The A Trigger Generator consists of U2260 and associated circuitry. Figure 4-5 shows a simplified diagram of the A Trigger Generator.

(a) Sequence of Events During Trigger Generation. The following discussion will follow the sequence of events in the A Trigger Generator. Refer to Figure 4-5 throughout the discussion.

1 **During Holdoff.** Point E is held HI by the holdoff gate at pin 17 of U2260. Point I is held HI by the complement sweep gate output at point L causing point J to be LO. Both of the arm latch inputs are LO. The output of the arm latch (point K) has previously been reset to HI (at the beginning of holdoff by the holdoff signal applied to pin 17 of U2260). When point K is HI, pin 14 will be held LO regardless of the trigger signal input. The sweep gate latch is held off.

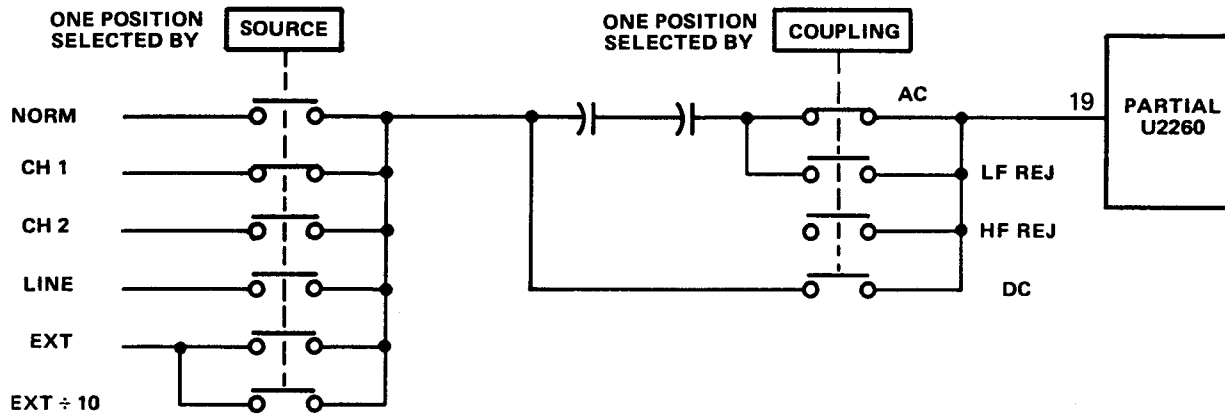

A. LOW-FREQUENCY TRIGGER SIGNAL PATH.

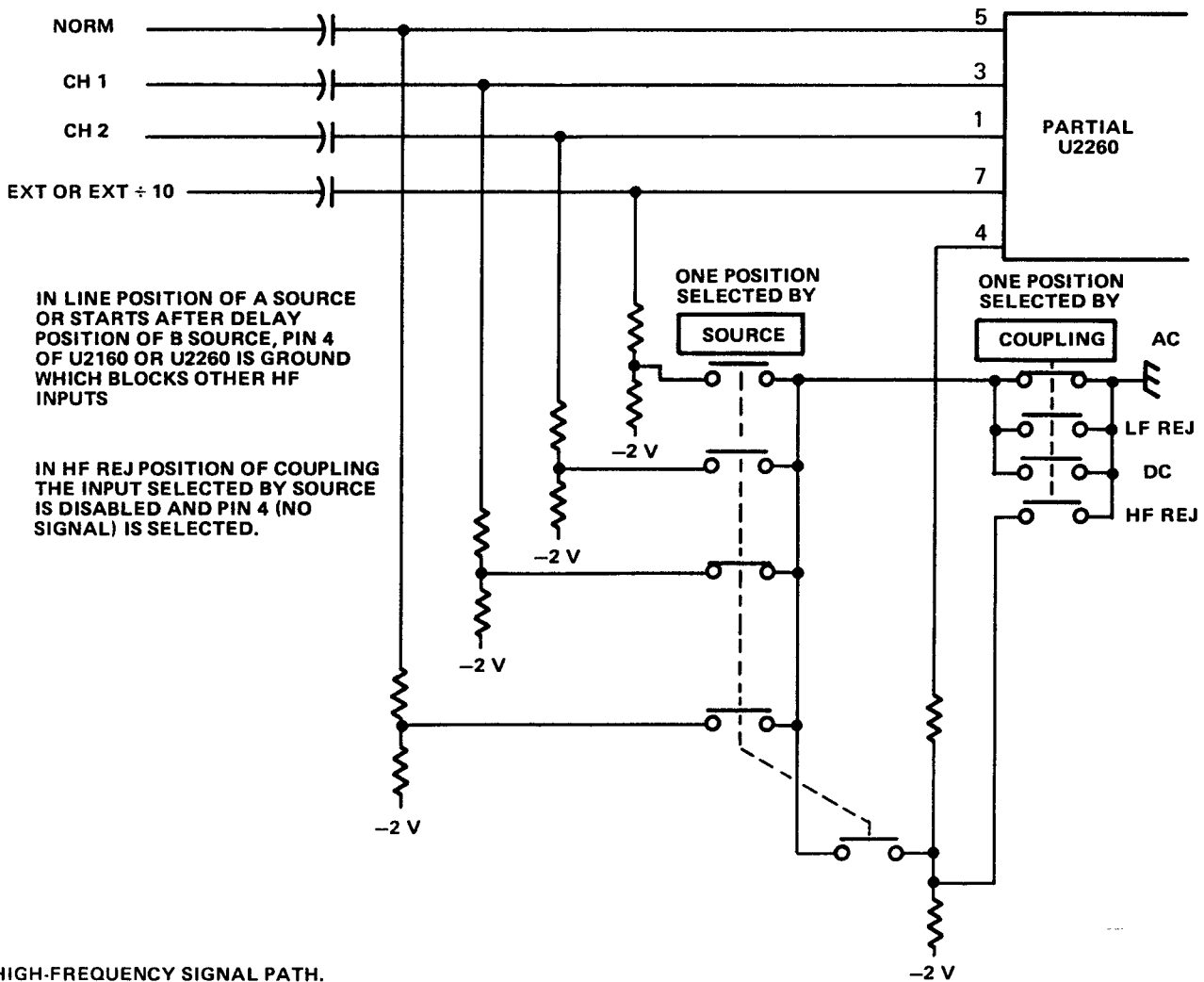

B. HIGH-FREQUENCY SIGNAL PATH.

Figure 4-3. Trigger switching.

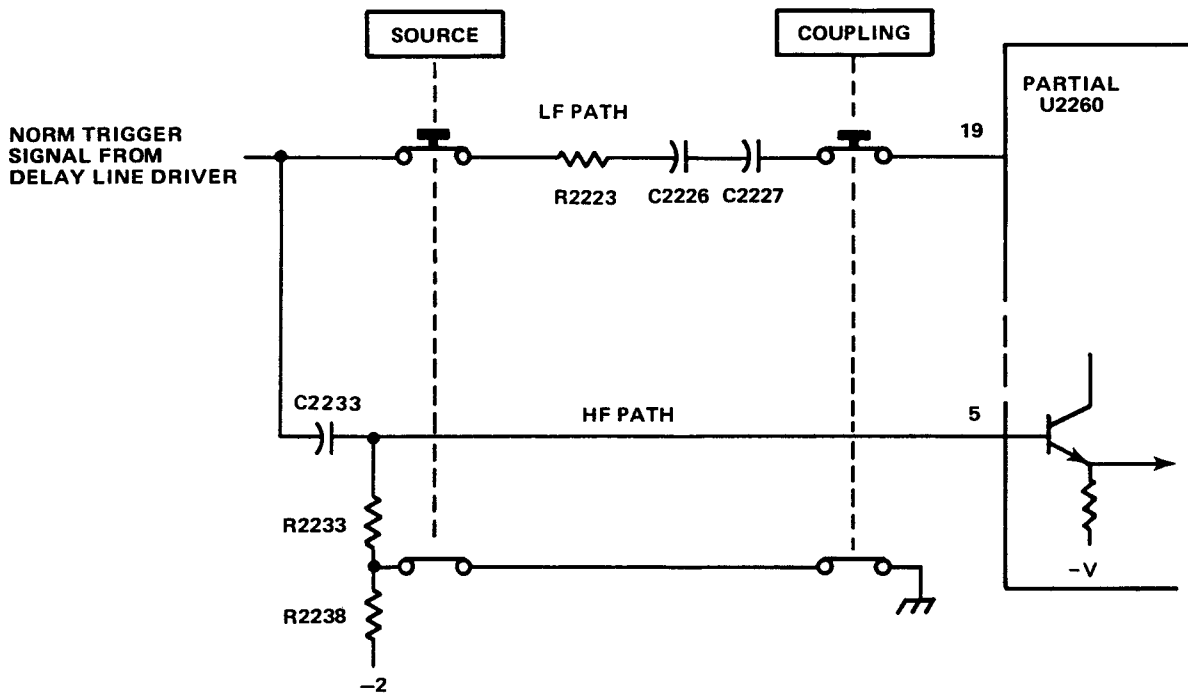

CONNECTING THE RESISTOR JUNCTION TO GROUND TURNS ON THE EMITTER FOLLOWER WITHIN U2260. DISCONNECTING THE GROUND CONNECTS THE BASE TO -2 V, THRU R2233 AND R2238, AND TURNS OFF THE EMITTER FOLLOWER.

Figure 4-4. Trigger signal paths with SOURCE set to NORM and COUPLING set to AC.

2 At the End of Holdoff. At the end of hold-off, pin 17 of U2260 steps LO causing point H to step HI. There are now two possibilities depending on the state of the signal at point A. If the trigger input signal at point A is above the 3.55 volt threshold at the end of holdoff, no further changes will occur at this time. The HI at point K will continue to hold pin 14 LO. If the trigger input signal at point A is below the 3.55 volt threshold at the end of holdoff (or the first time after the end of holdoff the trigger input signal falls below the 3.55 volt threshold), point D goes LO setting point F HI. This sets the arm latch causing point K to go LO. With point K LO, the sweep gate latch will be allowed to change states.

3 After the Arm Latch Sets. After the arm latch sets, the first voltage at point A that is more positive than the 3.65 volt threshold, causes point B to go HI. This causes the output of the sweep gate latch (pin 14 of U2260) to go HI. The HI on pin 14 causes the A Sweep Generator to begin generating a sweep ramp.

4 Beginning of Holdoff. At the end of A Sweep time, the holdoff gate at pin 17 of U2260 steps HI. This causes point H to step LO. Point I is set to LO whenever the sweep gate (at pin 14) is HI. With points H and I both LO, point J momentarily steps HI. This resets the arm latch causing point K to go HI. When point K goes HI, the sweep gate goes LO and point I goes HI setting point J LO. The holdoff condition described in paragraph 4-3. b. (2) (a) 1 is restored.

(b) Slope Selection. The slope of the trigger input signal, on which a sweep gate is generated, is determined by the voltage connected to pin 8 of U2260. When the voltage is negative, the signal at point A is inverted (see Figure 4-5).

(c) LEVEL Control. The LEVEL control (R2253) shifts the dc level of the signal appearing at point A. This changes the position on the signal where the signal passes through the threshold voltage.

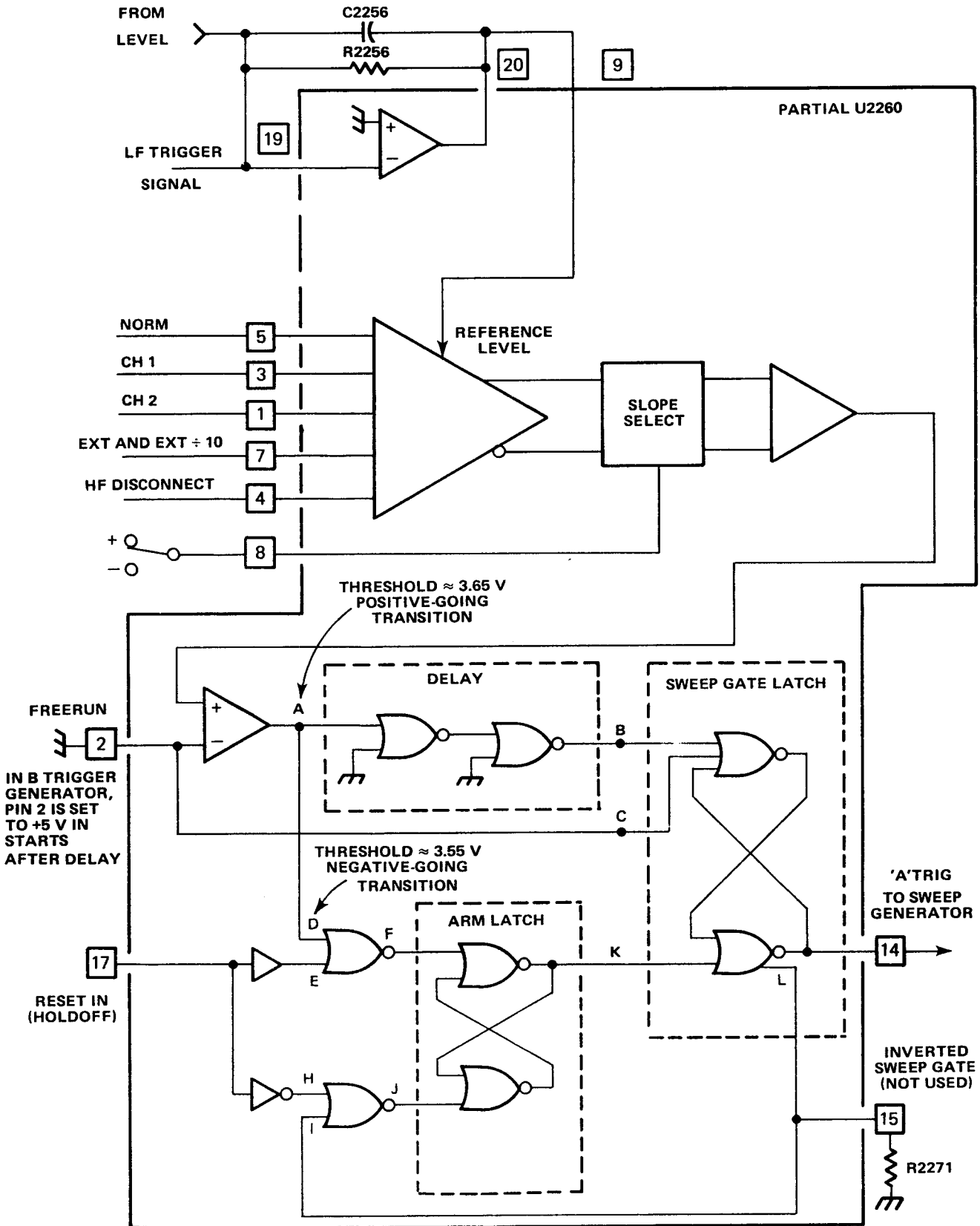

Figure 4-5. A trigger generator.

(d) Hysteresis Adjustment. The hysteresis adjustment (R2245) sets the difference in the trigger threshold and the arm threshold. The closer the levels are to each other, the more susceptible the circuit will be to triggering on noise. If the levels are too far apart, the circuit will require excessive input signal amplitude to generate a sweep gate.

(e) Trigger View Pickoff. A sample of the trigger input signal is supplied to pins 10 and 11 of U2260. This paraphase signal passes through emitter followers Q2350 and Q2356 to the TRIG VIEW switch (S4380). When the TRIG VIEW switch is pushed, the signal from the Delay Line Driver is disconnected from the Delay Line and the trigger view signal is connected in its place.

(3) B Trigger Generator. The B Trigger Generator operates in the same manner as the A Trigger Generator except in the STARTS AFTER DELAY position of the HORIZ DISPLAY switch. In the STARTS AFTER DELAY mode, +5 volts is connected to pin 2 of U2160 through S2100 and S2650 (see Figure 4-5). This disconnects the trigger signal from point B, sets point D LO, and sets point C HI. At the end of holdoff, point E goes LO causing point F to go HI. This sets point K LO and, because of the HI always present on point C, causes a sweep gate to be generated.

(4) A Sweep Generator. A sweep generator consists of U2790 and associated circuitry. Figure FO-6 shows a complete schematic diagram of the circuit. Figure 4-6 shows a simplified diagram of the circuit. Figure 4-7 shows the waveforms produced during A sweep generation.

(a) Sweep Generator Integrated Circuits. Both the A and B Sweep Generator integrated circuits (U2790 and U2690 respectively) are the same. However, the functions of some of the pins are different. The following lists the pin numbers and their functions:

1 Pin 1 is the input for the DELAY TIME POS control. This pin is only used in the A Sweep Generator. When the A ramp on pin 2 is equal to the voltage on pin 1, a delayed gate is produced at pin 16.

2 Pin 2 is the input for the ramp voltage from the output Miller circuit. This voltage is internally connected to pin 5 when pin 7 is LO.

3 Pin 3 sets internal current levels.

4 Pin 4 sets the Miller null and retrace currents for the A Sweep Generator only. This function is performed by another circuit in the B Sweep Generator.

5 Pin 5 is the sweep ramp output. The ramp at pin 5 is connected to the Horizontal Preamplifier. Pin 5 is switched on or off by the voltage on pin 7.

6 Pin 6 sets the internal current levels which, along with R2682 or R2782, determine the sweep start voltage.

7 Pin 7 controls the sweep ramp output at pin 5. When pin 7 is LO the sweep ramp at pin 2 is internally connected to pin 5. When pin 7 is HI, the sweep ramp at pin 2 is disconnected from pin 5 and pin 5 is set to -5 volts.

8 Pin 8 is the connection for the -5 volt supply.

9 Pin 9 is the ground connection.

10 In the A sweep Generator, pin 10 produces an output which initiates holdoff. In the B Sweep Generator, pin 10 produces an output which is supplied to the +B GATE OUT Amplifier in the Main Module.

11 The voltage connected to pin 11 sets the amplitude of the unblanking signal at pin 12.

12 The signal at pin 12 is supplied to the Z Axis Amplifier in the Main Module to unblank the crt. The amplitude of this signal, and therefore the brightness of the crt display, is controlled by the voltage on pin 11.

13 Pins 13 and 14 work together. A HI on either pin prevents sweep generation. Both must be LO to start sweep generation. In the A Sweep Generator, pin 13 is held LO through a resistor to ground and only pin 14 controls sweep generation. In the B Sweep Generator pin 14 goes LO when the A Sweep Generator starts but pin 13 doesn't go LO until the B Trigger Generator produces a sweep gate. In the STARTS AFTER DELAY position of the B SOURCE switch, a B sweep gate is produced as soon as pin 16 of U2790 produces a delayed gate. In other settings, a B sweep gate is produced when the first adequate trigger signal occurs after a delayed gate is produced at pin 16 of U2790.

14 Pin 14 works with pin 13. See the pin 13 discussion.

15 Pin 15 is the connection for the +5 volt supply.

16 Pin 16 of the A Sweep Generator produces a delayed gate to remove the holdoff condition from the B Trigger Generator. This output is produced when the A ramp voltage on pin 2 reaches the dc level on pin 1.

(b) Sequence of Events During A Sweep Generation.

1 Quiescent Condition. The quiescent condition exists during holdoff and after holdoff but before the A Trigger Generator produces a sweep start gate. Pin 14 of

U2790 is HI. This sets point A (see Figure 4-6) HI. This causes the output of the sweep start comparator to appear as a low-impedance point. The output of the sweep start comparator supplies current through pin 4 of U2790, and through R_T , to set the inverting input of the Miller op amp to the same voltage as the non-inverting input (the sweep

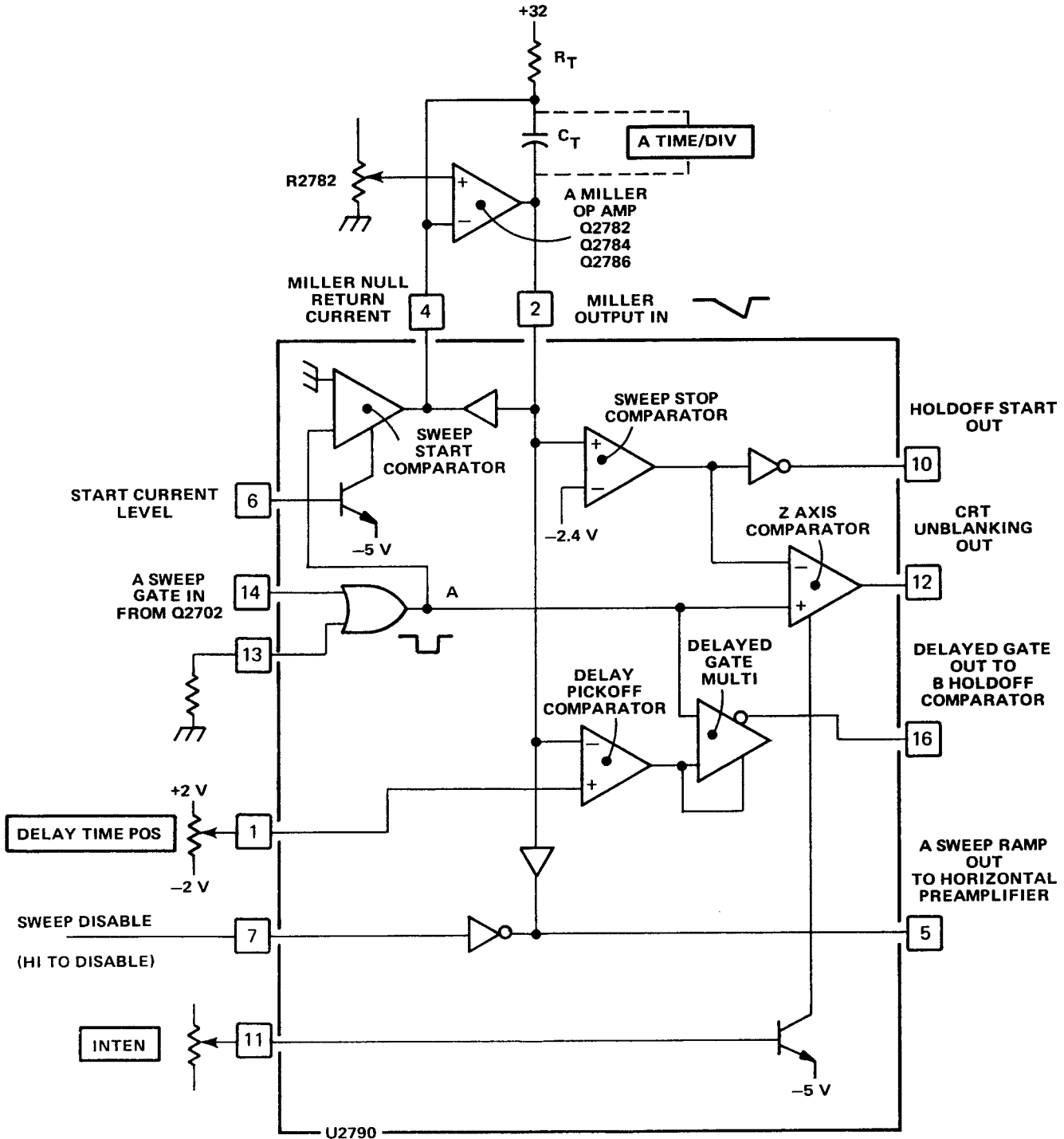

Figure 4-6. Simplified diagram of the A sweep generator.

start voltage which is set by R2782). The output of the Miller op amp sets pin 2 of U2790 to the sweep start voltage also.

2 At Triggering. Pin 13 is always LO, except in the X-Y mode. When pin 13 is HI, point A (see Figure 4-6) is HI regardless of the state of pin 14. When the sweep gate causes pin 14 to go LO, point A steps LO (see Figure 4-6). This causes the output of the sweep start comparator to become a high-impedance point. The timing capacitor (C_t) starts charging through the timing resistor (R_t).

3 During Ramp Generation. As C_t starts charging through R_t , the inverting input of the Miller op amp tries to go more positive. This causes the output of the Miller op amp to go less positive which supplies current through C_t and R_t to hold the voltage on the inverting input constant. Since the resulting voltage across R_t is constant, the current through R_t and C_t must also be constant. Charging C_t with this constant current produces a linear negative-going voltage ramp at pin 2 of U2790. The slope of the ramp is determined by the values of R_t and C_t which are selected by the A TIME/DIV switch (S3100). The ramp at pin 2 is internally connected to pin 5 of U2790 whenever pin 7 is LO. Pin 7 is HI in the MIXED and B DLY'D positions of the HORIZ DISPLAY switch and LO in the A and A INTEN positions of the HORIZ DISPLAY switch and in the X-Y mode.

4 At Delayed Gate Generation. The negative-going ramp at pin 2 of U2790 is internally connected to a comparator. The ramp is compared to the dc voltage on pin 1 of U2790 (set by the DELAY TIME POS control). When the ramp voltage is the same as the voltage on pin 1, the comparator triggers the delayed gate multivibrator supplying a negative-going gate pulse to pin 16 of U2790. This gate is connected to the B holdoff comparator (Q2672 and Q2674) and terminates B holdoff. The negative-going gate from pin 16 of U2790 is also connected to the base of Q2622 through CR2608, CR2617, CR2618, and CR2622. This allows the B sweep gate, from the B trigger amplifier (Q2602 and Q2604), to start B sweep generation. Both signals must be LO at the same time to start B sweep.

5 Sweep End. The ramp on pin 2 of U2790 is internally connected to the sweep stop comparator. When the ramp reaches -2.4 volts, the comparator switches supplying a positive-going pulse to pin 10 of U2790. This pulse is supplied to the Sweep Control circuit and initiates A holdoff. At the beginning of holdoff, the sweep gate causes pin 14 of U2790 to step HI causing pin 4 to again appear as a low-impedance point. The current through R_t is now supplied by pin 4 of U2790. Also, when pin 14 of U2790 steps HI, it causes pin 12 to step HI and initiate B holdoff.

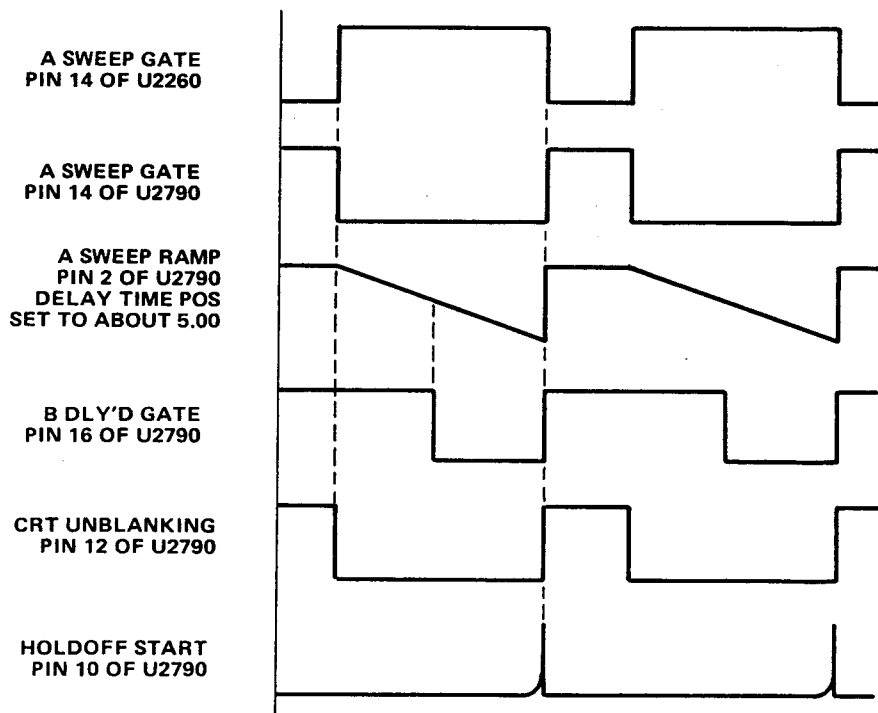

Figure 4-7. Waveforms produced during A sweep operation.

Operation Instructions

6 Retrace. At the beginning of holdoff, the output of the Miller op amp and pin 2 of U2790 are at about -2.4 volts. This voltage is supplied to the input of a non-inverting amplifier within U2790. This amplifier tries to pull pin 4 of U2780, and the inverting input of the Miller op amp, less positive. To compensate, the output of the Miller op amp rapidly goes positive discharging C_t . The resulting positive-going ramp provides retrace.

(5) B Sweep Generator. The B Sweep Generator consists of U2690 and associated circuitry. The B Sweep Generator integrated circuit (U2690) is the same as the A Sweep Generator integrated circuit (U2790). Both are discussed in paragraph 4-3. b. (4) (a). Figure 4-8 shows a simplified diagram of the B Sweep Generator. Figure 4-9 shows the waveforms produced during B sweep generation. Figure FO-6 shows a complete schematic diagram of the B Sweep Generator.

(a) Sequence of Events During B Sweep Generation in B DLY'D or A INTEN Mode. Refer to Figure 4-8 and Figure 4-9 during the following discussion. Figure FO-6 shows a complete schematic diagram of the B Sweep Generator.

1 Before B Delayed Gate Generation. In the B DLY'D or A INTEN modes, the base of Q6236 is set to about $+2$ volts through the HORIZ DISPLAY switch (S2650). The following conditions exist before the generation of a B delayed gate at pin 16 of U2790. The B trigger amplifier (Q2602 and Q2604) supplies a HI to the base of Q2622 which biases off Q2622. The B sweep start voltage (about $+2$ volts from pin 2 of U2690) is applied to the base of Q2632. Bias resistors set the base of Q2636 to about $+2$ volts also. Ideally Q2632 and Q2636 will conduct equally. The emitter of Q2624 is connected to the collector of Q2636 which forward biases Q2624. The collector of Q2624 pulls the emitter of Q2620 negative enough (through CR2621) to turn on Q2620. Transistor Q2620 supplies current through R_t to hold the inverting input of the B Miller op amp at the same voltage as its non-inverting input (set by R2682).

2 At B Delayed Gate Generation. When the A Sweep Generator generates a B delayed gate (at pin 16 of U2790), the resulting negative step on the base of Q2672, causes the B holdoff comparator (Q2672 and Q2674) to switch states and remove B holdoff from the B Trigger generator.

3 At B Sweep Gate Generation. When a B sweep gate is generated by the B Trigger Generator, the B trigger amplifier (Q2602 and Q2604) switches, which pulls the base of Q2622 negative. Transistor Q2622 turns on, pulling the emitter of Q2620 less negative. This turns off Q2620. This begins generation of a B ramp. When the B

ramp (at pin 2 of U2690) begins going less positive, it turns off Q2636. The emitter of Q2624 is now connected to -5 volts through R2638. Transistor Q2624 remains on, supplying the collector current for Q2622.

4 During B Ramp Generation. When Q2620 turns off, C_t begins charging through R_t . As C_t charges, the inverting input of the B Miller op amp tries to go more positive. To compensate, the output of the B Miller op amp supplies current through C_t and R_t to hold the inverting input at the same voltage as the non-inverting input (set by R2682). Since the resulting voltage across R_t is constant, the current through R_t and C_t is constant. Charging C_t with this constant current produces a linear negative-going ramp at pin 2 of U2690. The slope of the ramp is determined by the values of R_t and C_t which are selected by the B TIME/DIV switch (S3200). The ramp at pin 2 of U2690 is internally connected to pin 5 whenever pin 7 is LO. Pin 7 is LO in the B DLY'D mode and HI in the A INTEN mode. The B Sweep Generator does not provide horizontal deflection in the A INTEN mode, it only supplies additional unblanking current to intensify the display during the time a B sweep ramp is being generated.

5 Sweep Stop. When the ramp at pin 2 of U2690 reaches about -2.4 volts, the emitter of Q2629 becomes sufficiently negative to forward bias Q2629. When Q2629 turns on its collector becomes sufficiently negative to turn on Q2620. The resulting current through Q2620 flows through R_t and holds the inverting input of the B Miller op amp at the same voltage as the non-inverting input. The B Miller op amp no longer supplies current to C_t and the voltage on pin 2 of U2690 remains at about -2.4 volts. The B Sweep Generator does not reset at this time. If it did reset, it might be possible to trigger and generate another B sweep ramp before A sweep ends. This would produce an erroneous display. The gate at pin 10 of U2690 does not initiate B holdoff, it only supplies a signal to the +B GATE OUT Amplifier in the Main Module.

6 Retrace. At the end of a sweep, the holdoff gate from the Sweep Control circuit resets both the A and B Trigger Generators. When the B Trigger Generator resets, the B trigger amplifier (Q2602 and Q2604) switches and pulls the base of Q2622 HI. This turns off Q2622. When Q2622 turns off, it allows the collector of Q2629 to pull the emitter of Q2620 more negative which increases the forward bias on Q2620. The increased forward bias on Q2620 tries to increase the current through R_t and force the inverting input of the B Miller op amp less positive. To compensate, the output of the B Miller op amp rapidly goes positive, discharging C_t . The resulting positive-going ramp on pin 2 of U2690 provides retrace.

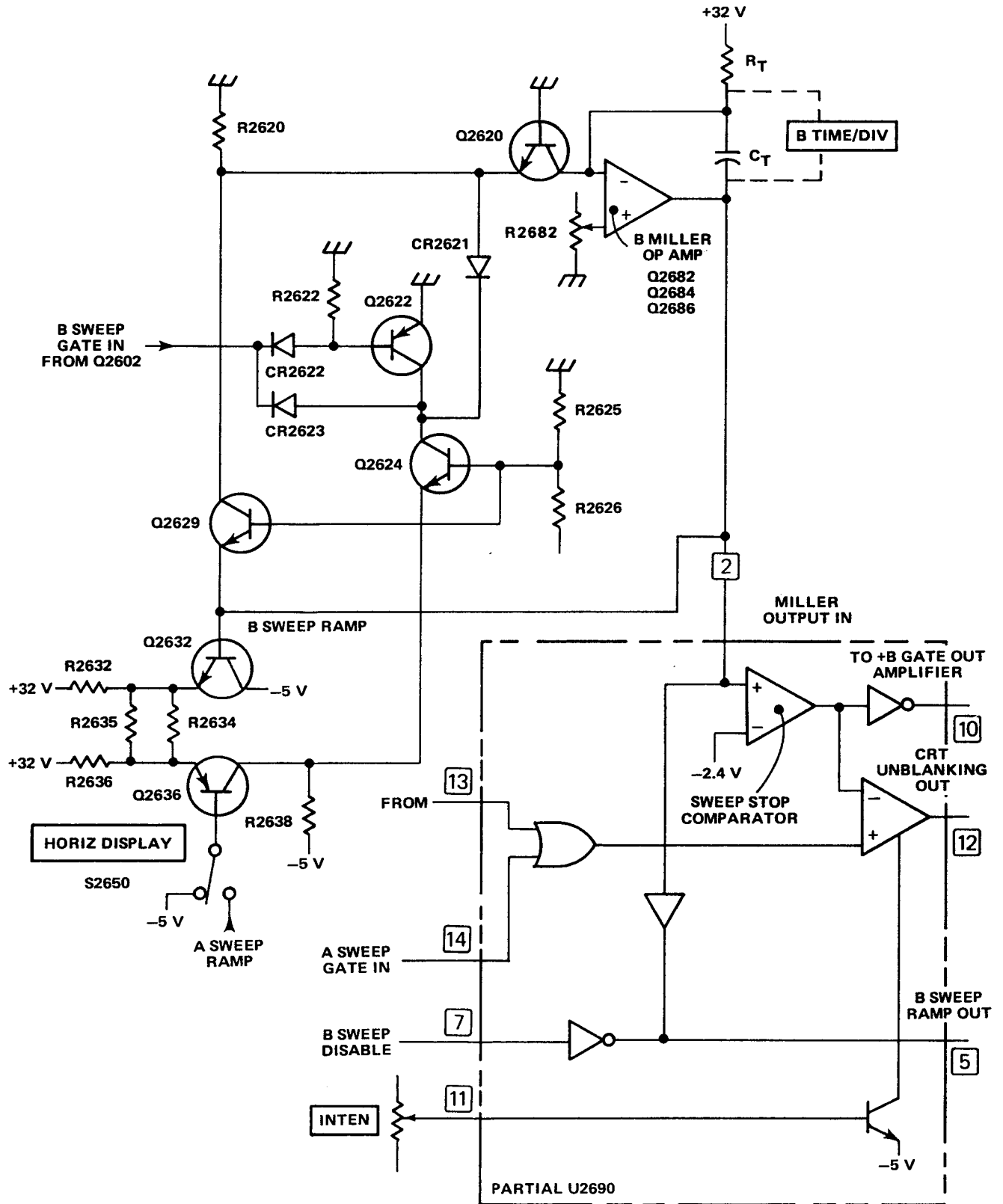

Figure 4-8. Simplified diagram of the B sweep generator.

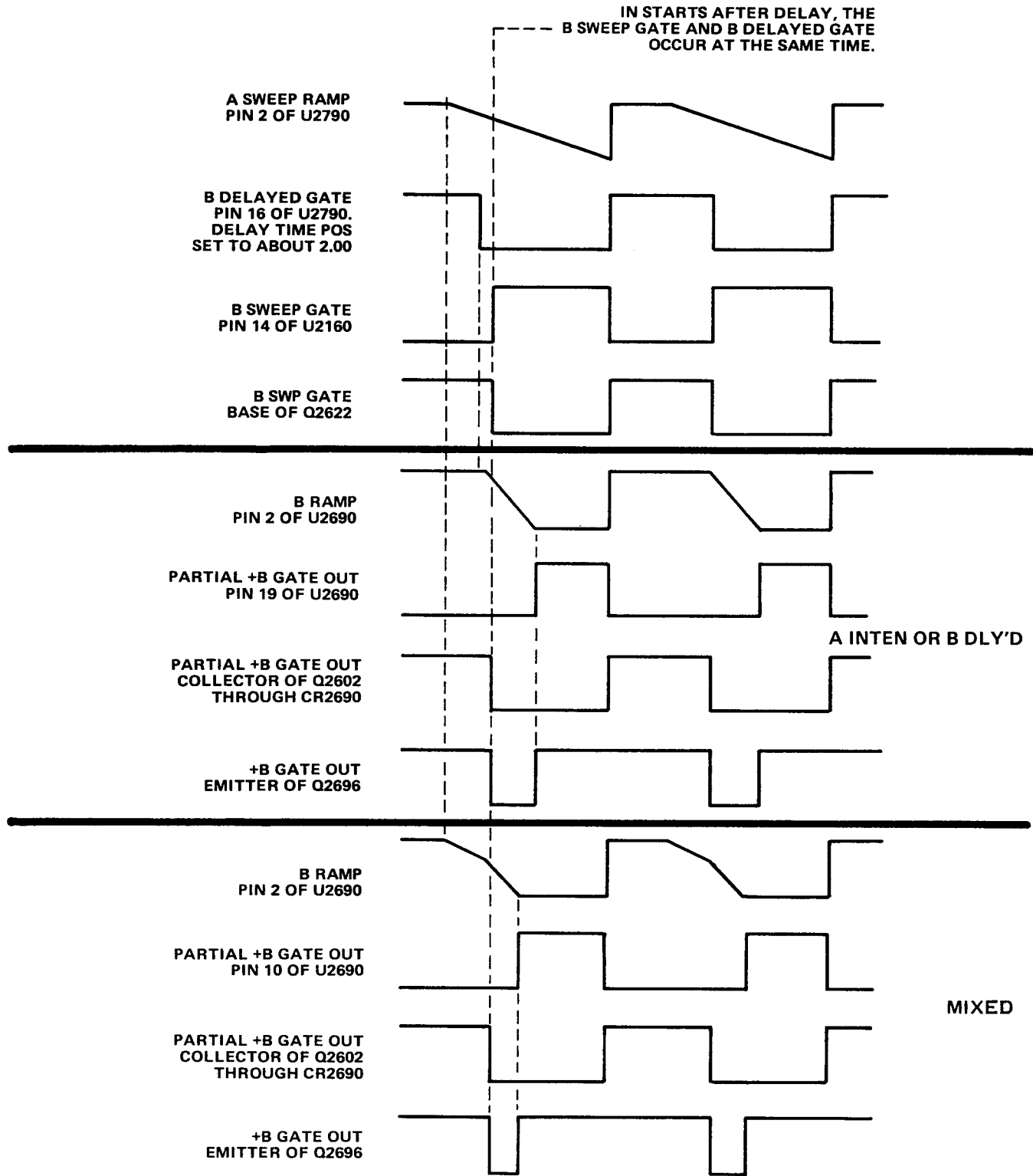

Figure 4-9. Waveforms produced during B sweep generation

7 End of Retrace. When the retrace ramp on pin 2 of U2690 reaches about +2 volts, the emitter of Q2636 (through the emitter of Q2632) is pulled sufficiently positive to forward bias Q2636. At the same time, the emitter of Q2629 becomes sufficiently positive to turn off Q2629. The initial condition (before B delayed gate generation) is restored. The collector of Q2636 goes less negative, decreasing the forward bias on Q2624. Now Q2624 supplies just enough current through Q2620 and R_T to hold the inverting and non-inverting inputs of the B Miller op amp at the same voltage.

(b) Sequence of Events During B Sweep Generation in MIXED Mode. In the MIXED mode, B sweep generation is similar to that in the A INTEN or B DLY'D modes. The main difference is that the voltage level on pin 2 of U2690 is controlled by the A sweep ramp before a B sweep gate is generated. Also, a HI is placed on pin 7 of U2790 causing pin 5 of U2790 to go LO and disconnect the A ramp from the Horizontal Preampfier.

1 Before A Sweep Starts. When the MIXED button is pushed, the A sweep ramp is connected to the base of Q2636 through R2637 and R2781. Ideally the A and B sweep start voltages will be about the same, causing both Q2636 and Q2632 to conduct. The collector of Q2636 is connected to the emitter of Q2624, forward biasing Q2624. The collector of Q2624 pulls the emitter of Q2620 negative enough to forward bias Q2620. Transistor Q2620 supplies current through R_T to hold both inputs of the B Miller op amp at the same voltage. Also, a HI from the B trigger amplifier (Q2602 and Q2604) holds off Q2622.

2 After A Sweep Starts. When the A Sweep Generator is triggered, the negative-going A sweep ramp begins to appear at pin 2 of U2790 which is connected to the base of Q2636. As the base of Q2636 goes less positive, Q2636 turns on harder causing its collector to go less negative. The collector of Q2636 is connected to the emitter of Q2624. As the collector of Q2636 goes less negative, the forward bias on Q2624 is decreased, which decreases its collector current. Since Q2624 supplies the current through Q2620, the current through Q2620 also decreases. This causes the inverting input of the B Miller op amp to try to go more positive. To compensate, the output of the B Miller op amp supplies current through C_T and R_T to hold both inputs at the same voltage. C_T charges at a rate determined by the A sweep ramp. The resulting ramp at pin 2 of U2690 has the same slope as the A sweep ramp and is internally connected to pin 5 of U2690. This signal is connected to the Horizontal Preampfier and provides horizontal deflection for both the A and B portions of the display.

3 When B Sweep Gate is Generated. When a B sweep gate is generated by the B Trigger Generator, the base of Q2622 steps negative, turning on Q2622 which

turns off Q2620. B sweep generation continues as in the A INTEN or B DLY'D modes. See 4-3. b. (5) (a) 3 through 7.

(6) Horizontal Preampfier.

(a) The Horizontal Preampfier is contained within a single integrated circuit (U2900). The Horizontal Preampfier amplifies the sweep ramp outputs from the A and B Sweep Generators and supplies the amplified signal to the Horizontal Amplifier in the Main Module. In the X-Y mode, the CH 1 Preampfier output is supplied to the Horizontal Preampfier to provide horizontal (X axis) deflection.

(b) The following lists the pin numbers of U2900 and their functions.

1 Pin 1, Magnifier Registration. Used in conjunction with pin 8 to adjust magnifier registration. Adjustment is correct when display does not shift horizontally when switching between normal and magnified displays.

2 Pin 2, Sweep. Output for the negative-going signal which is supplied to the Horizontal Amplifier in the Main Module.

3 Pin 3, Gain. Used in conjunction with pin 6. The resistance between pins 3 and 6 determines the amplitude of the signal at pins 2 and 7. Decreasing this resistance increases gain. The X10 Magnifier switch, when pushed, decreases this resistance by a factor of ten and therefore increases the gain by a factor of ten.

4 Pin 4, -5 Volts. Connection for the -5 volt supply.

5 Pin 5, Current Source. Sets current levels within U2900.

6 Pin 6, Gain. See pin 3.

7 Pin 7, +Sweep. Output for positive-going signal which is supplied to the Horizontal Amplifier in the Main Module.

8 Pin 8, Magnifier Registration. See pin 1.

9 Pin 9, B Sweep Input. The output of the B Sweep Generator is connected here. The more positive of the levels connected to pins 9 and 10 is internally connected to the amplifier and provides the output at pins 2 and 7. The more negative level on pins 9 and 10 is ignored.

10 Pin 10, A Sweep Input. The output of the A Sweep Generator is connected here. See pin 9.

11 Pin 11, X Signal Input. A sample of the signal present in the CH 1 Preamplicifier is connected here. When pin 12 is HI, the sweep inputs from pins 9 and 10 are internally disconnected and the signal from pin 11 is amplified and connected to the outputs on pins 2 and 7.

12 Pin 12, X-Y Control. This pin is set HI only in the X-Y mode. See pin 11.

13 Pin 13, Frequency Compensation. The frequency compensating capacitor is connected here.

14 Pin 14, Horizontal Position. The horizontal POSITION control is connected here. Changing the dc voltage on this pin shifts the dc level of the outputs at pins 2 and 7, except in the X-Y mode.

(7) +A GATE OUT Amplifier. The +A GATE OUT Amplifier consists of Q2712 and associated circuitry. The A sweep gate signal from the collector of Q2702 (part of the A trigger amplifier) is connected to the base of Q2712. At the beginning of A sweep the sweep gate turns off Q2712, causing its collector to go to +5 volts. At the end of A sweep the sweep gate steps positive, turning on Q2712. The collector of Q2712 goes to about 0 volts. The resultant +A GATE OUT signal is about +5 volts while an A sweep ramp is being generated and about 0 volts the rest of the time.

(8) +B GATE OUT Buffer. The +B GATE OUT Buffer consists of Q2696 and associated circuitry. The input to the buffer circuit is obtained from three sources; the partial B Gate signal from pin 10 of U2690, the B sweep gate from the collector of Q2602 which is part of the B trigger amplifier, and the delayed gate signal from pin 16 of U2790. Figure 4-9 shows the time relationship of the two signals. The output of the Buffer is LO only when both input signals are LO. All three input signals are LO at the same time only while a B ramp is being generated. The output of the Buffer is supplied to the +B GATE OUT Amplifier in the Main Module.

(9) Sweep Control. Sweep Control consists of U2750 and associated circuitry. The circuit controls holdoff duration, AUTO sweep, and single sweep operation. Figure 4-10 shows a functional block diagram of U2750 and associated circuitry.

(a) Holdoff Control. Holdoff control is provided by a Miller ramp generator which consists of three transistors within U2750, and an RC network. Resistors R2776 and R2777 are the timing resistors. Capacitor C2762 and a capacitor selected by the A TIME/DIV switch are the timing capacitors. Figure 4-10 shows a functional block diagram of U2750 and associated circuitry. Figure 4-11

shows the waveforms produced by the holdoff control circuitry.

1 At the beginning of A sweep generation, pin 6 of U2750 steps LO. This LO passes through an inverting amplifier and turns on transistor C and turns off transistors D and E (see Figure 4-10). When transistors D and E turn off, pin 11 of U2750 is pulled more positive through R2762. Pin 11 is clamped at about +5.7 volts by a diode within U2750. The current through the timing resistors (R2776 and R2777) is supplied by transistor C through pin 10 of U2750. This condition is maintained until the end of A sweep generation.

2 At the end of A sweep generation, pin 12 of U2750 momentarily steps HI which sets the holdoff latch within U2750. The Q output of the holdoff latch goes HI causing pin 9 of U2750 to go HI. The HI on pin 9 resets and holds off the A Trigger Generator.

3 When the A Trigger Generator resets (or the AUTO sweep gate steps HI), pin 6 of U2750 steps HI. This turns off transistor C and turns on transistors D and E within U2750. Pin 10 is pulled positive to about +1.4 volts through R2776 and R2777.

4 After transistor C turns off, pin 10 tries to go more positive than +1.4 volts. This turns on transistor D harder and supplies current through C2762, R2776, and R2777. This current holds pin 10 at about +1.4 volts and begins charging C2762. As C2762 charges, pin 11 of U2750 begins going less positive.

5 As pin 11 of U2750 goes less positive, the diode selected by the A TIME/DIV becomes forward biased. Now the current to hold pin 10 at +1.4 volts is supplied through C2762 and a capacitor selected by the A TIME/DIV. Since the voltage across R2776 and R2777 doesn't change, the current doesn't change. Now this current must charge two capacitors, and the voltage ramp on pin 11 of U2750 will not be as steep. The ramp can also be made less steep by increasing the resistance of the A TRIGGER HOLDOFF control (R2777).

6 When the voltage on pin 11 falls to about 1 volt, the R input of the holdoff latch within U2750 is set HI through an inverting amplifier. The holdoff latch resets and its Q output goes LO. When the Q output goes LO, pin 9 of U2750 goes LO and terminates holdoff.

(b) AUTO Sweep Control. When pin 4 of U2750 is set LO by the TRIG MODE switch, Sweep Control provides a baseline trace in the absence of an adequate trigger signal. Figure 4-10 shows the Sweep Control integrated circuit and associated circuitry. Figure 4-12 shows the waveforms produced during AUTO sweep gate generation.

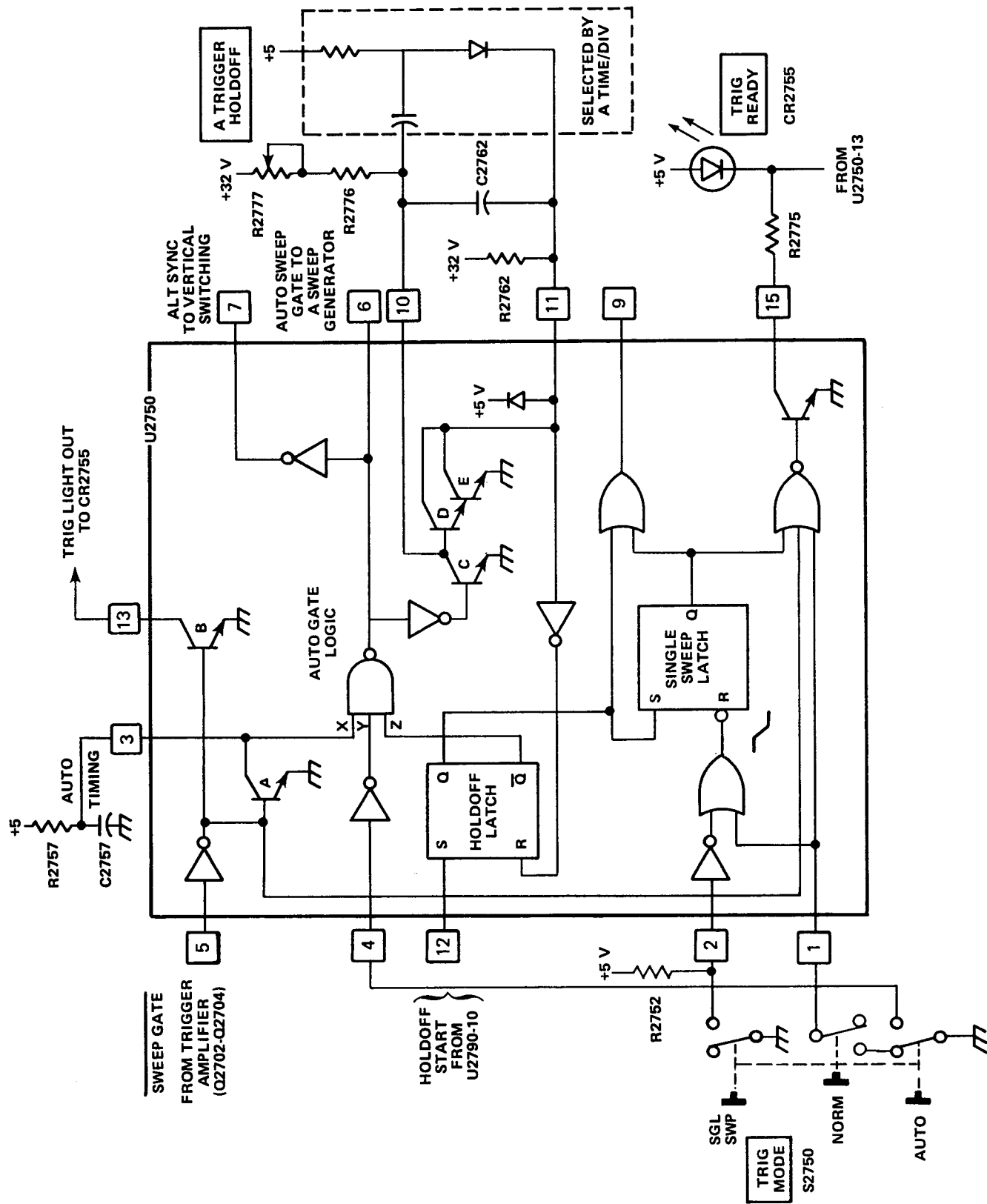

Figure 4-10. Functional block diagram of the sweep control integrated circuit and associated circuitry.

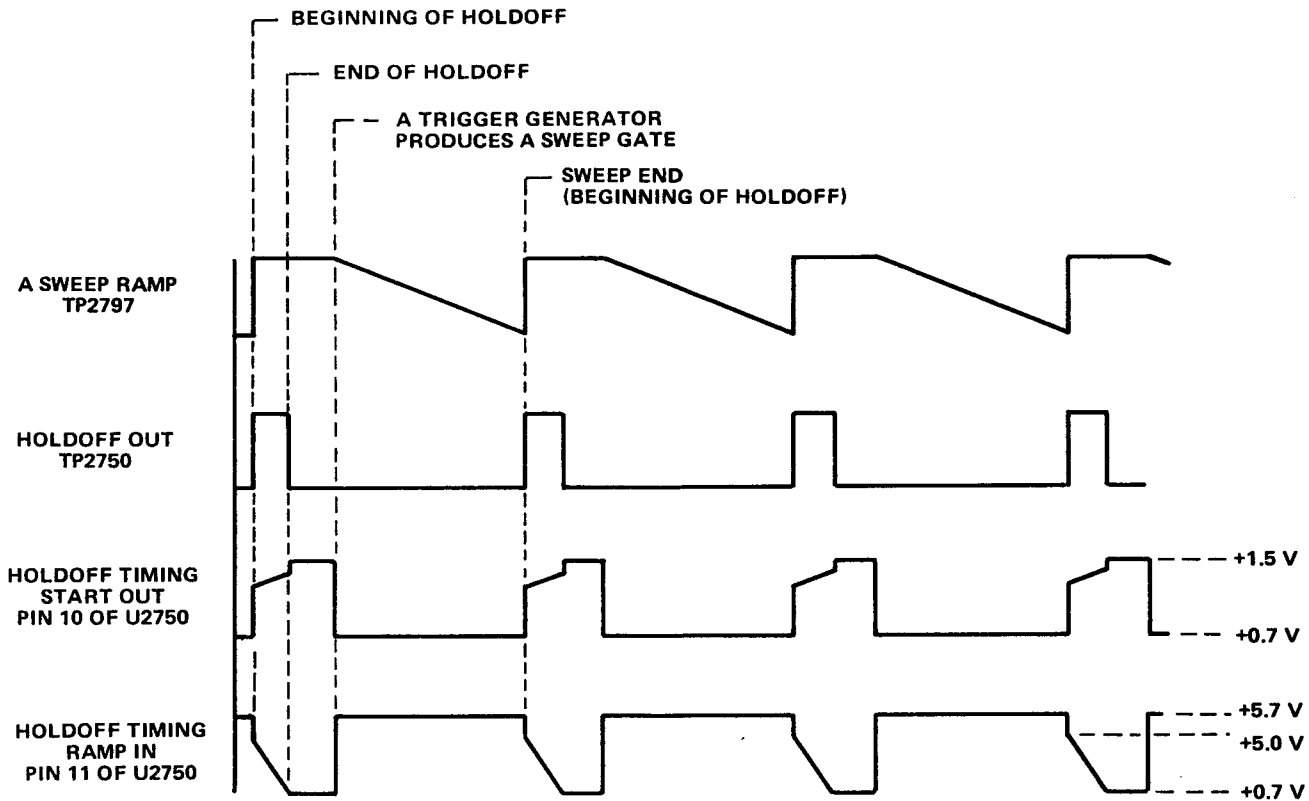

Figure 4-11. Waveforms produced by holdoff control circuitry.

1 When the TRIG MODE switch (S2750) is set to AUTO, pin 4 of U2750 is set LO. This sets input Y of the AUTO gate logic HI through an inverting amplifier within U2750 (see Figure 4-10).

2 If adequately triggered, pin 5 of U2750 steps LO at the beginning of A sweep generation. This turns on transistor A within U2750 and discharges C2757. Discharging C2757 prevents generation of an AUTO sweep gate by keeping input X of the AUTO gate logic LO.

3 Assume that the trigger signal becomes inadequate to cause the A Trigger Generator to generate an A sweep gate. At the end of the last triggered sweep, pin 12 of U2750 momentarily steps HI. This sets the holdoff latch within U2750. The Q output of the holdoff latch sets input Z of the AUTO gate logic HI.

4 When the holdoff latch sets, pin 9 of U2750 resets the A Trigger Generator causing pin 5 of U2750 to step HI. The HI on pin 5 turns off transistor A within U2750. Now C2757 starts to charge through R2757.

5 When C2757 charges sufficiently, input X of U2750 is HI. Now all three inputs of the AUTO gate logic are HI which causes an AUTO sweep gate to be generated at pin 6 of U2750.

6 At the end of the first AUTO generated sweep ramp, pin 12 of U2750 momentarily steps HI, resetting the holdoff latch. The \bar{Q} output of the holdoff latch goes LO, causing the output of the AUTO gate logic to step HI. At the same time, the Q output of the holdoff latch steps HI, causing holdoff to begin (pin 9 of U2750 steps HI).

7 When holdoff ends, the R input of the holdoff latch goes HI, resetting the holdoff latch. The Q output goes HI, causing the AUTO gate at pin 6 of U2750 to step LO. This causes another AUTO sweep to be generated. As long as no adequate trigger signal is available, all subsequent sweeps will be initiated by the AUTO gate at pin 6 of U2750.

8 Assume an adequate trigger signal becomes available. When A Trigger Generator supplies an A sweep gate to pin 5 of U2750, transistor A within U2750 is turned

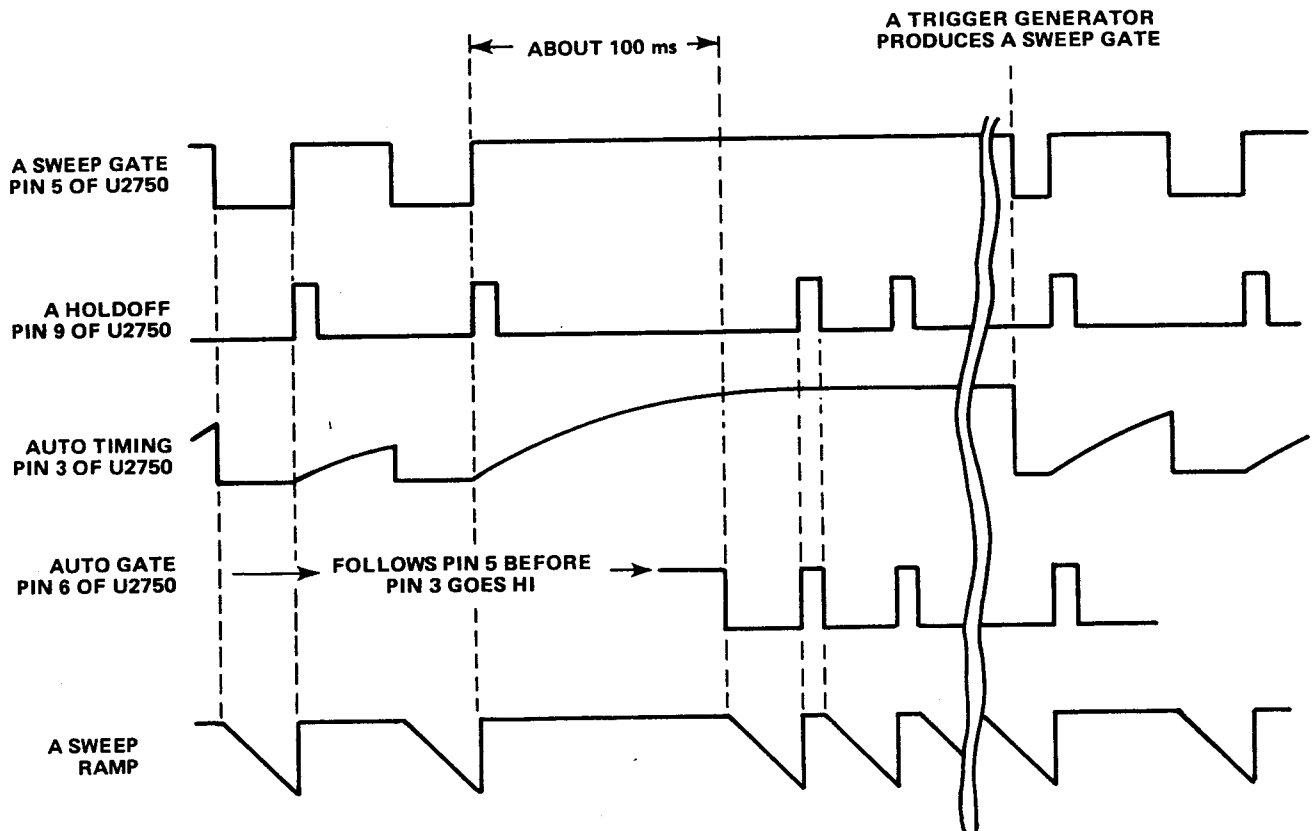

Figure 4-12 Waveforms produced during AUTO sweep gate generation.

on. Capacitor C2757 discharges rapidly through transistor A. This sets input X of the AUTO gate logic LO which disables the logic. Now another AUTO gate can not be generated at pin 6 of U2750 until C2757 charges enough to set input X of the AUTO gate logic HI (about 100 milliseconds after the beginning of holdoff).

(c) Single Sweep Control. When the TRIG MODE switch (S2750) is set to SGL SWP, pin 1 of U2750 is connected to ground. Now, when adequately triggered, only one sweep ramp will be generated. After one sweep is displayed, another sweep can't be presented until after the SGL SWP button has been pushed. Figure 4-10 shows a functional block diagram of the Sweep Control integrated circuit and associated circuitry.

1 To operate in the single sweep mode, pin 1 of U2750 is grounded and pin 2 is pulled HI through R2752. This holds the R input of the single sweep latch within U2750 HI.

2 At the end of sweep ramp generation, the Q output of the holdoff latch steps HI. This HI is connected to the S input of the single sweep latch and sets the latch. The Q output of the single sweep latch holds pin 9 of

U2750 HI even after the holdoff latch has reset. This permanently holds off the A Trigger Generator.

3 To reset the single sweep latch, the SGL SWP button must be pushed and released. When the SGL SWP button is pushed, pin 2 of U2750 is set LO which sets the R input of the single sweep latch HI. When the SGL SWP button is released, pin 2 of U2750 steps HI causing a negative going transition on the R input of the single sweep latch. This transition resets the single sweep latch. The Q output of the single sweep latch goes LO which sets pin 9 of U2750 LO and terminates holdoff.

c. Main Module.

(1) Z-Axis Amplifier. Figure FO-9 shows the Z-Axis Amplifier circuitry. The Z-Axis Amplifier consists of Q514, Q518, Q524, Q526 and associated circuitry.

(a) Normal Z-Axis Amplifier Operation. The Z-Axis Amplifier accepts signals from several sources, amplifies them, and supplies a control signal to the CRT Circuit to control display intensity. The sources of the signals used to control display intensity are: Vertical Switching Control circuit, A Sweep Generator, and the B Sweep Generator.

1 The Z Axis Amplifier input signals are applied to the emitter of common base amplifier Q514. Transistor Q514 provides isolation between the signal sources and the Z Axis Amplifier. The algebraic sum of the signals applied to the emitter of Q514 determines the current supplied to the base of Q518.

2 Transistor Q518 is an emitter follower. The signal on the emitter of Q518 drives Q524 and Q526.

3 Transistors Q524 and Q526 are connected as a complementary symmetry amplifier. The signal from the emitter of Q518 drives both bases and the output is taken from the junction of the two collectors. This output signal is supplied to the crt control grid through the dc restorer portion of the CRT Circuit.

(b) BEAMFINDER Z-Axis Amplifier Operation.

When the BEAMFINDER button is pushed and held, the Z Axis Amplifier ignores the input signals and provides a visible display.

1 With the BEAMFINDER button pushed and held, +32 volt is disconnected from R512 and +5 volts is connected to R504.

2 The +5 volts connected to R504 reverse biases CR506 and CR505. This disconnects the input signals from the emitter of Q514.

3 When +32 volts is removed from R512, the base of Q518 is pulled slightly more negative through R514. This sets conduction in Q518 at a level which provides a visible display regardless of the Z Axis Amplifier input signals.

(2) Crt Circuit. Figure FO-9 shows the CRT Circuit. The CRT Circuit provides the high voltage levels needed to operate the crt. The CRT Circuit consists of the high voltage oscillator, high voltage regulator, high voltage rectifier, high voltage multiplier, and dc restorer.

(a) High Voltage Oscillator. The high voltage oscillator consists of Q552, Q556, T550 and associated circuitry. Figure 4-13 shows the waveforms produced in the high voltage oscillator.

1 To explain the high voltage oscillator, we must choose a given point in an oscillation and describe the sequence of events. Assume pin 3 of T550 is going more positive and pin 5 is going less positive.

2 As pin 3 of T550 goes more positive, the voltage across the feedback winding of T550 (between pins 3 and 6) adds to the voltage on C548. When the voltage on pin 3 becomes sufficiently positive, it pulls the base of Q552 positive enough to turn on Q552.

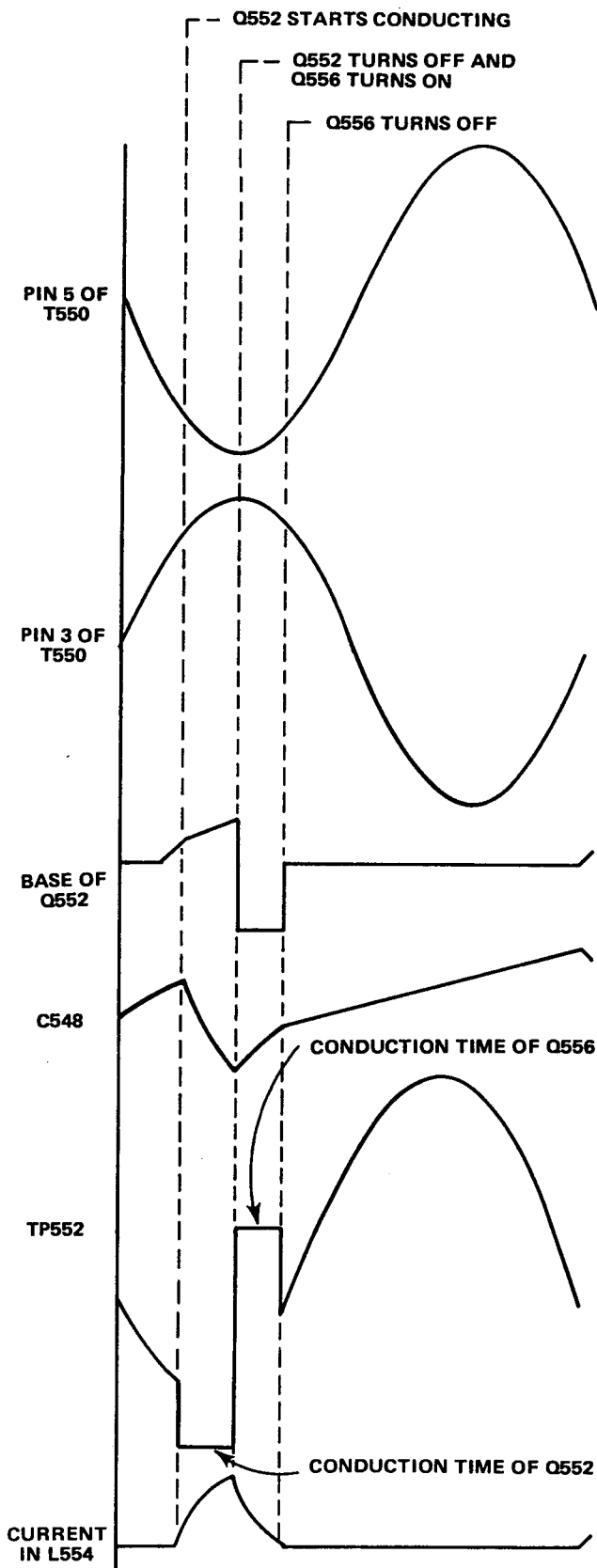

Figure 4-13. Waveforms produced in the high voltage oscillator

3 As Q552 turns on, current is drawn through T550 and L554. This current induces positive feedback into the feedback coil of L554 and turns on Q552 harder. The voltages induced into the feedback coils of T550 and L554 hold Q552 on.

4 As the magnitude of the current in T550 and L554 increases, the rate of change of the current decreases. When the rate of change of the current reaches about zero, the voltage induced in the feedback windings of T550 and L554 becomes insufficient to hold Q552 on. Q552 begins to turn off. Note that at this instant the voltage across the secondary of L554 is 0 volts.

5 As Q552 is turning off, the magnetic field around L554 starts collapsing. This induces a voltage in the feedback winding of L554 which speeds up the turnoff of Q552.

6 The collapsing magnetic field of L554 induces a voltage in L554 which forces the emitter of Q556 more positive. This voltage causes the emitter of Q556 to go more positive than pin 4 of T550. As a result, Q556 turns on and places L554 in parallel with the primary winding of T550.

7 The current produced by the collapsing magnetic field of L554 flows through Q556 and the primary winding of T550. This transfers the energy stored in L554 to T550 and increases the efficiency of the circuit. The amount of energy stored in L554 is controlled by the high voltage regulator.

8 As the oscillation cycle continues, the voltage across L554 decreases until it is not sufficient to hold Q556 on. Therefore Q556 turns off.

9 The cycle continues until pin 3 of T550 again becomes sufficiently positive to turn on Q552. Then the sequence just described repeats.

(b) High Voltage Regulator. The high voltage regulator consists of Q544, Q548, and associated circuitry. Figure FO-9 shows the high voltage regulator circuitry. The high voltage regulator controls the output of the high voltage oscillator by controlling the energy in the primary circuit. To fully understand the high voltage regulator, read the previous High Voltage Oscillator discussion before continuing with this discussion.

1 The high voltage regulator controls the point during an oscillation cycle that Q552 is turned on. Assume the -2 kV supply starts to go more negative (too much energy is transferred to the secondary circuit of T550).

2 As the -2 kV supply goes more negative it pulls the base of Q554 less positive. The collector of Q544 goes more positive which decreases the collector current of Q548. Transistor Q548 supplies charge current to C548. Because the collector current of Q548 is decreased, C548 charges more slowly. As a result, the voltage on pin 3 of T550 will not become positive enough to turn on Q552 until later in the oscillation cycle (see Figure 4-13). Therefore less energy is stored in L554 and transferred to the primary of T550 when Q556 turns on. This decreases the amount of energy transferred to the secondary of T550 which causes the -2 kV supply to go less negative.

3 If the -2 kV supply goes less negative, Q544 and Q548 turn on harder charging C548 faster. The voltage on pin 3 of T550 becomes positive enough to turn on Q552 earlier in the oscillation cycle. Therefore more energy is stored in L554 and transferred to the primary of T550 when Q556 turns on. As a result, more energy is transferred to the secondary circuit of T550 and the -2 kV supply goes more negative.

4 In the event the high voltage regulator malfunctions, VR552, VR553, and CR552 provide over-voltage protection. If the peak voltage on pin 8 of T550 exceeds about $+200$ volts, VR552 conducts. When VR552 and VR553 conduct they turn on Q552 which draws enough current to open fuse F558.

(c) High Voltage Rectifier. Figure 4-14 shows a simplified diagram of the high voltage rectifier. Figure FO-9 shows the high voltage rectifier and associated circuitry.

1 The high voltage rectifier is contained within U550. The circuit half wave rectifies the -2 kV peak ac signal at pin 9 of T550. The rectified and filtered voltage is supplied to the crt cathode, dc restorer, FOCUS control, and the high voltage regulator.

2 The heater supply winding of T550 is referenced to the -2 kV supply. This prevents breakdown between the heater and the cathode due to a large voltage difference between them.

(d) High Voltage Multiplier. Figure FO-9 shows the high voltage multiplier. The circuit is a standard voltage multiplier consisting of diodes and capacitors. The multiplication factor is 3. The multiplier is contained within module U550. The output of the multiplier supplies the positive anode voltage for the crt.

(e) DC Restorer. The dc restorer is contained within U550. Figure 4-15 shows a simplified diagram of the circuit.

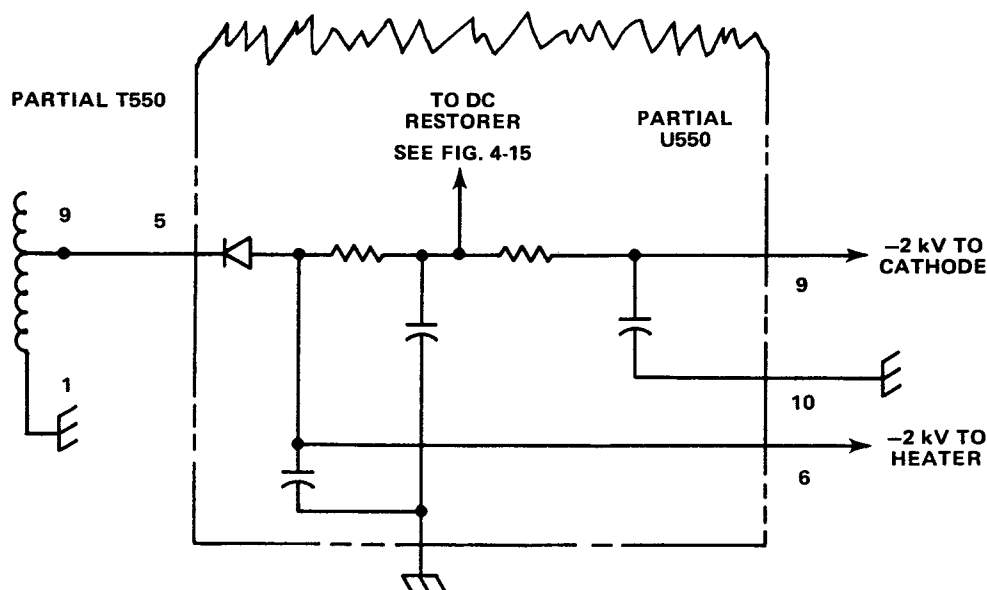

Figure 4-14. High voltage rectifier.

1 To control the crt beam current, and therefore display intensity, the voltage on the crt control grid is varied through the dc restorer. How negative the control grid is with respect to the cathode is determined by the difference in the voltages from the crt bias setting and the Z Axis Amplifier.

2 The voltages from the bias control and the Z Axis Amplifier will vary; however, to make this discussion easier to understand, assume the bias control sets pin 2 of U550 to +100 volts and the Z Axis Amplifier sets pin 1 of U550 to +20 volts.

3 On positive-going excursions of the voltage on pin 8 of T550, diode C clamps the voltage at point X to about the voltage on pin 2 of U550 (see Figure 4-15). We have assumed this voltage to be about 100 volts. Point Y is clamped at about -2 kV by diode G. Capacitor E charges to the difference between the -2 kV supply and pin 2 of U550 (about 2.1 kV). Note that diode F is reverse biased. When the voltage on pin 8 of T550 falls below the level on pin 1 of U550 (set by the Z Axis Amplifier), diode B clamps point X at about the voltage on pin 2 of U550 (+20 volts assumed). Since the voltage on capacitor E can't be changed instantaneously, point Y steps negative by an amount equal to the difference in the levels at which diodes B and C conduct (80 volts assumed) Point Y steps negative to -2080 volts. This is 2100 volts (the charge on capacitor A) more negative than the conduction level of diode B.

4 When point Y steps to -2080, diode G becomes reverse biased and diode F becomes forward biased.

Point Y sets the crt grid to about -2080 volts or about 80 volts more negative than the cathode. While diode F is forward biased, capacitor E discharges slightly into capacitor A. This replaces the charge that leaks off capacitor A while diode F is reverse biased.

5 When the oscillation on pin 8 of T550 again becomes sufficiently positive, the original condition is restored. Diode C clamps point X at about 100 volts and diode F is reverse biased. While diode F is reverse biased, the charge on capacitor A holds the crt control grid at about -2080 volts.

6 The action just described is fairly slow. To provide rapid intensity changes, the rapid voltage changes from the Z Axis Amplifier are supplied directly to the control grid through capacitor A.

(3) Horizontal Amplifier. Figure FO-8 shows the Horizontal Amplifier circuitry. The Horizontal Amplifier provides the final signal amplification to drive the horizontal deflection plates of the crt. The circuit consists of two single ended feedback amplifiers. Transistor Q234 is a constant voltage source for the input stages of both amplifiers (Q232 and Q274). The collectors of Q232 and Q274 drive the bases of complementary symmetry amplifiers Q244-Q246 and Q284-Q286 respectively. The signals in the two amplifiers are 180 degrees out of phase with each other.

(4) +B GATE OUT Amplifier. Figure FO-8 shows the +B GATE OUT Amplifier circuitry.

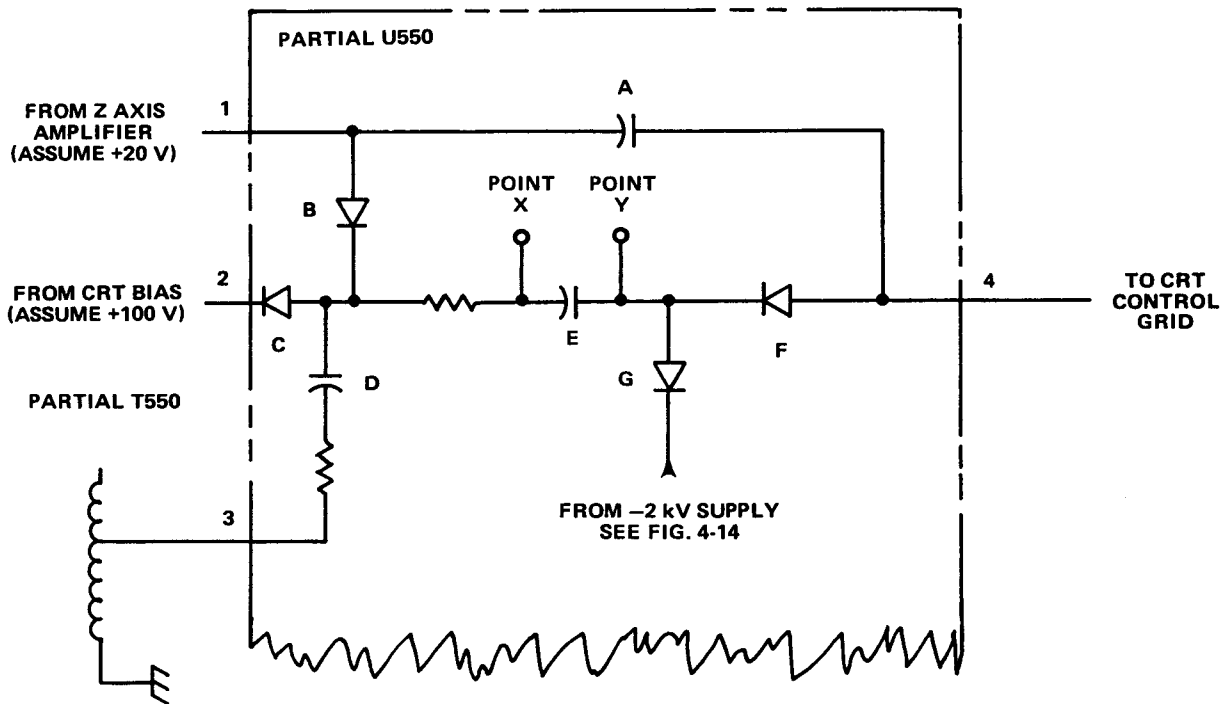

[A] DC RESTORER CIRCUITRY

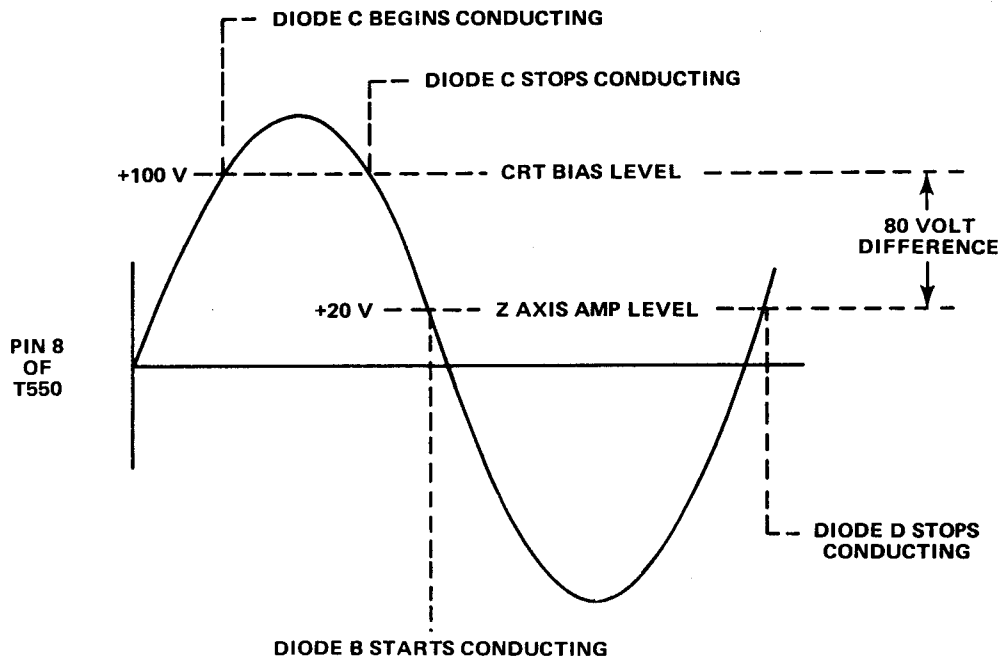

[B] THEORETICAL DC RESTORER WAVEFORM (NOT MEASURABLE)

Figure 4-15. Dc restorer.

(a) The +B GATE OUT Amplifier amplifies the signal from the +B GATE OUT buffer. The output of this circuit is connected to a rear panel mounted BNC connector. The output signal steps to about +5 volts during B sweep ramp generation and about 0 volts the rest of the time. The circuit consists of inverting amplifier Q356, emitter follower Q358, and associated circuitry.

(b) When the input of the circuitry goes more positive, Q356 turns on hard and its collector goes to about +0.7 volts. This causes the emitter of Q358 to go to about 0 volts.

(c) When the input steps less positive, Q356 turns off and the base of Q358 is pulled more positive through R354. The emitter of Q358 is prevented from going more positive than +5.1 volts by VR353.

(5) **Calibrator.** Figure FO-8 shows the Calibrator circuitry. The Calibrator generates an accurate 1.0 volt square wave for use in probe compensation and checking vertical gain accuracy. The circuit consists of an astable multivibrator and an output amplifier.

(a) **Multivibrator.** Transistors Q376 and Q382 form an astable multivibrator. The multivibrator runs at approximately 1 kilohertz. The frequency is determined by the RC time constant of C376-R377-R375. Transistors Q376 and Q382 conduct alternately, producing a square wave output signal at the collector of Q382. Diodes CR372 and CR373 limit the charge on C376 to about 18 volts to prevent damage to Q376 or Q382 when either transistor is removed while the instrument is operating.

(b) **Output Amplifier.** The square wave output signal from the collector of Q382 drives the output amplifier (Q386). Transistor Q386 is alternately driven into saturation, then into cutoff. This results in a 0 to +5 volt square wave at the collector of Q386. Amplitude adjustment R386 sets the collector current in Q386 to produce a 1 volt square wave across R388. This 1 volt square wave is connected to J387 on the instrument front panel.

(6) **Low Voltage Power Supplies.** Figure FO-10 shows the Low Voltage Power Supplies, except for the +95 volt supply. Figure FO-9 shows the +95 volt supply.

(a) **Primary Circuit.** All the supplies except the +95 volt supply receive power from T700. To reduce electromagnetic interference, the ac supply voltage is filtered by a filter which is part of P700. There are two windings in the primary of T700. These windings can be placed in series or parallel by the line voltage selector switch (S701). The two windings are placed in series for operation from a 232 volt power source or in parallel for operation from a 116 volt power source.

(b) **+32 Volt Supply.** Figure FO-10 shows the +32 volt supply. The +32 volt supply consists of U722A, Q732, Q734, Q736 and associated circuitry.

1 Operational amplifier U722A controls regulation of the +32 volt supply. The noninverting input of U722A is set to +9 volts by VR722. The output of the +32 volt supply sets the inverting input of U722A at +9 volts through voltage divider R735-R736-R737.

2 The output of U722A (about +9 volts) is level shifted by a zener diode (VR725). This level shifted voltage controls the base drive of Q732 and Q736 which are connected as a Darlington amplifier. Transistor Q734 provides overcurrent protection.

3 Regulation occurs as follows. Assume the +32 volt supply tries to go less positive. This is sensed on the wiper of R736 and causes the inverting input of U722A to try to go less positive. As a result, the output of U722A goes more positive which turns on Q732 and Q736 harder. When Q736 turns on harder, the +32 volt supply goes more positive which corrects for the original deviation.

(c) **+5 Volt Supply.** Figure FO-10 shows the +5 volt supply. The +5 volt supply consists of U722B, Q742, Q744, Q746 and associated circuitry.

1 The reference voltage for the +5 volt supply is obtained from the +32 volt supply through R741 and R742. The reference voltage sets the noninverting input of U722B to +5 volts.

2 The inverting input of U722B senses changes in the +5 volt supply through R743.

3 The output of U722B controls conduction in Q744 and Q746 which are connected as a Darlington amplifier. The conduction level of Q746 controls the +5 volt supply output voltage. Transistor Q742 provides overcurrent protection for the +5 volt supply.

(d) **-5 Volt Supply.** Figure FO-10 shows the -5 volt supply. The -5 volt supply consists of U762, Q764, Q766, Q768 and associated circuitry.

1 In the -5 volt supply, the noninverting input of the operational amplifier (U762) is not referenced to the +32 volt supply as in the +5 volt supply. Instead it is connected to ground (0 volts) through R764.

2 The inverting input of U762 does not directly sense the supply output voltage as in the +5 volt supply. Instead the inverting input senses both the +32 and -5 volt supplies through voltage divider R763-R762. This sets the inverting input to 0 volts. Since the +32 volt supply is constant, changes in the -5 volt supply are sensed at the inverting input.

3 The output of U762 is level shifted by several series connected diodes. The level shifted voltage controls the conduction of Q766. The collector of Q766 controls the conduction of Q768 which controls the -5 volt supply output voltage. Transistor Q764 provides overcurrent protection for the -5 volt supply.

4 Regulation of the -5 volt supply occurs as follows. Assume the -5 volt supply tries to go more negative. This tries to force the inverting input of U762 negative. The output of U762 drives the base of Q766 less negative. This causes Q768 to conduct less, causing its collector to go less negative and correct the original condition.

(e) Overcurrent Protection. The following describes overcurrent protection for the +32 volt supply. Overcurrent protection for the +5 volt and -5 volt supplies operates in a similar manner.

1 As the load on the +32 volt supply increases, the voltage dropped across R734 (the current sensing resistor) also increases. As the voltage across R734 increases it forces the emitter and the base of Q736 more positive.

2 When the load on the +32 volt supply becomes excessive, the voltage on the base of Q736 becomes sufficiently positive to forward bias Q734 through R732 and R733. As Q734 begins to conduct, it reduces the forward bias on Q732 and Q736 causing the +32 volt supply output to go less positive. The greater the load on the +32 volt supply the more Q734 conducts and the less positive the +32 volt supply goes.

3 The current sensing resistors for the +5 and -5 volt supplies are R748 and R768 respectively.

(f) +95 Volt Supply. Figure FO-9 shows the +95 volt supply. The +95 volt supply consists of CR582 and associated circuitry. The +95 volt supply is powered by the high voltage oscillator through T550. The ac voltage on pin 2 of T550 is half wave rectified by CR582. The half wave rectified voltage is filtered by C582, L582, and C584. Regulation is provided by the high voltage regulator.

4-4. FUNCTIONS OF CONTROLS, CONNECTORS, AND INDICATORS. The location of controls, connectors, and indicators is shown on Figure FO-1 in the foldout section at the rear of this manual. Detailed function descriptions are listed in Table 4-2.

Table 4-2. Functions of Controls, Connectors, and Indicators

Figure/index no.	Control, connector, or indicator name	Function
FO-1/1	LINE RANGE	Selects the line voltage range on which the instrument is to be operated. The ranges are indicated on the rear panel.
2	Fuse Holder	Contains the instrument line fuse.
3	Power Cord Connector	Connects the detachable power cord to the instrument.
4	POWER	Turns the instrument on and off. Pull to turn on; push to turn off.
5	ON Indicator	Indicates when power is applied to the instrument; flashes if the line voltage drops below allowable limits.
6	INTEN	Controls the brightness of the crt display.
7	ASTIG	Screwdriver adjustment used in conjunction with the FOCUS control to initially obtain a well defined display. Once set, usually requires little or no adjustment.
8	FOCUS	Adjusts for a well defined display during normal operation.
9	TRACE ROTATION	Screwdriver adjustment used to align the trace with horizontal graticule line.
10	CALIBRATOR	Provides a one volt, one kilohertz, square wave output for setting probe compensation and checking vertical gain.
11	Graticule	Internal graticule prevents parallax errors. Rise and fall time measurement points are indicated on the left edge, and near the top and bottom horizontal portions of the graticule.
12	BEAM FINDER	Locates an off screen display. When pushed, a compressed display is visible within the graticule area. This display is independent of position controls, intensity setting, or applied signals.
13	SCALE ILLUM	Controls graticule illumination.
14	VERT MODE	Selects the operating mode for the vertical deflection system. CH 1: Displays only signals applied to the CH 1 input connector. ALT: Signals applied to CH 1 and CH 2 input connectors are alternately displayed. The alternation occurs during retrace at the end of each sweep. Useful at sweep rates of 0.5 milliseconds/division or faster. The display begins to flicker at rates slower than 0.5 milliseconds/division; therefore, the CHOP mode should be used at these rates. ADD: Displays the algebraic sum of the signals applied to the CH 1 and CH 2 input connectors. CHOP: Signals applied to CH 1 and CH 2 input connectors are alternately displayed at a fixed rate of about 250 kilohertz. Useful at sweep rates of 0.5 milliseconds/division or slower. At rates above 0.5 milliseconds/division the chopped segments become visible; therefore, the ALT mode should be used.

Table 4-2. Functions of Controls, Connectors, and Indicators—Continued

Figure/index no.	Control, connector, or indicator name	Function
FO-1/14 (continued)		<p>CH 2 OR X-Y: Displays only signals applied to the CH 2 input connector. Must be selected for X-Y operation.</p> <p>TRIG VIEW or 20 MHz BW: Three position switch. When pulled out, the bandwidth of the vertical deflection system is limited to 20 megahertz; when pushed part way in the vertical bandwidth is normal; and when pushed completely in and held, the signal applied to the A Sweep trigger generator is displayed.</p>
15	VOLTS/DIV	Outer ring portion of the control selects the vertical deflection factor in a 1-2-5 sequence. Factors are calibrated when the VAR portion of the controls is in its fully clockwise detent position.
16	VAR	Inner knob portion of the VOLTS/DIV control. Provides continuously variable uncalibrated vertical deflection factors between calibrated settings. Extends the maximum vertical deflection factor to 125 volts/division when using a 10X probe. This control must be in its fully clockwise detent position for calibrated deflection factors.
17	Deflection Factor Indicator	A light colored area under the VOLTS/DIV control skirt, which indicates the vertical deflection factor associated with the probe being used. Check the attenuation factor of the probe and use the correspondingly marked light colored area.
18	UNCAL Indicator	Indicates when the VAR portion of the VOLTS/DIV control is out of its fully clockwise detent position and uncalibrated deflection factors are being used.
19	AC-GND-DC	<p>Selects the method of coupling the input signal to the vertical input amplifier.</p> <p>AC: Input signals are capacitively coupled, blocking any dc component. Low frequencies are attenuated about 3 dB at 10 hertz using a 1X probe and at 1 hertz using a 10X probe. Ac coupling may cause tilting of square wave signals below about 1 kilohertz.</p> <p>GND: Connects the vertical input amplifier to ground to provide a ground reference display (input signal is disconnected). Connects the input signal to ground through the ac input capacitor and a one megohm resistor to keep the input coupling capacitor precharged.</p> <p>DC: Input signals are directly coupled, thus passing all components of the signal to the input amplifier.</p>
20	Vertical Channel Input Connectors	Connects the Channel 1 and Channel 2 vertical input probes to the instrument. In the X-Y mode of operation, the CH 1 OR X input provides horizontal deflection and the CH 2 OR Y input provides vertical deflection.
21	POSITION	Provides vertical positioning control of the display. In the X-Y mode of operation, the CH 1 OR X control positions the display horizontally and the CH 2 OR Y control positions the display vertically.
22	INVERT	Inverts the Channel 2 display only.

Table 4-2. Functions of Control, Connectors, and Indicators—Continued

Figure/index no.	Control, connector, or indicator name	Function
FO-1/23	HORIZ DISPLAY	<p>Selects the mode of operation for the horizontal deflection system.</p> <p>A: Horizontal deflection is provided by the A sweep generator at a rate set by A TIME/DIV. The B sweep generator (delayed sweep) is disabled.</p> <p>MIXED: The first part of the sweep is displayed at a rate set by A TIME/DIV and the last part of the sweep is displayed at a rate set by B TIME/DIV. The relative amount of display controlled by each setting is determined by the setting on the DELAY TIME POS dial.</p> <p>A INTEN: Horizontal deflection is provided by the A sweep generator at a rate set by A TIME/DIV. The B sweep generator produces an intensified zone on the display. The length of time the display is intensified is about ten times the B TIME/DIV setting except when A sweep ends before B sweep. The location of the intensified zone on the display is determined by the DELAY TIME POS dial setting.</p> <p>B DLY'D: Horizontal deflection is provided by the B sweep generator at a rate set by B TIME/DIV. The A sweep generator continues to operate. With the B sweep SOURCE set to STARTS AFTER DELAY, the start of B sweep is delayed from the start of A sweep by a time determined by the settings of A TIME/DIV and DELAY TIME POS. To calculate the delay, multiply the A TIME/DIV setting by the DELAY TIME POS dial setting.</p>
24	POSITION	<p>Provides horizontal positioning control of the display, except in the X-Y mode of operation when the CH 1 OR X, POSITION control provides horizontal positioning.</p>
25	A AND B TIME/DIV	<p>Selects the sweep rate for the A and B sweep. The A sweep rate is set by rotating the outer ring portion of the control. The rate is shown between the two black lines on the clear skirt of the control. This rate is multiplied by the DELAY TIME POS setting when using the A INTEN or B DLY'D display modes. For calibrated sweep rates, the VAR knob portion of the control must be in the fully clockwise detent position.</p> <p>The B sweep rate is set by pulling the outer ring out and rotating it to a setting shown by the white line scribed on the ring.</p> <p>The X-Y mode of operation is selected with the A sweep rate control is set fully counterclockwise.</p>
26	VAR	<p>Inner knob portion of the A AND B TIME/DIV control. Provides continuously variable uncalibrated sweep rates between calibrated settings of the A TIME/DIV settings. Must be in its fully clockwise detent position for calibrated A sweep rates and delay times.</p>
27	UNCAL Indicator	<p>Indicates when the VAR portion of the A AND B TIME/DIV control is out of its fully clockwise detent position and the A sweep rates are not calibrated.</p>

Table 4-2. Functions of Control, Connectors, and Indicators—Continued

Figure/index no.	Control, connector, or indicator name	Function
FO-1/28	X10 MAG	Increases the displayed sweep rate by a factor of 10. Extends the fastest sweep rate to 5 nanoseconds/division. The magnified sweep display is the center one division of the unmagnified display (0.5 division from either side of the center vertical graticule line).
29	X10 MAG Indicator	Indicates when the X10 MAG is selected.
30	DELAY TIME POS	Provides a variable B sweep delay from 0.000 to 10.000 times the setting of the A TIME/DIV control.
31	TRIG MODE	<p>Selects the mode of operation for the A sweep trigger.</p> <p>AUTO: With proper trigger LEVEL and COUPLING settings, A sweep can be initiated by signals above about 20 hertz. In the absence of a triggering signal or with control misadjustments, the A sweep generator free-runs to provide a reference display.</p> <p>NORM: With proper trigger LEVEL and COUPLING settings, A sweep can be initiated by an input signal. In the absence of a triggering signal or with control misadjustments, the A sweep generator does not run and there is no display.</p> <p>SGL SWP: A momentary contact push button, which cancels previous TRIG MODE selections and selects a single sweep mode of operation. This mode operates the same as NORM, except only one sweep is displayed on a trigger signal. Another single sweep cannot be displayed until the SGL SWP push button is pressed to reset the trigger circuit.</p>
32	TRIG READY Indicator	Indicates the A sweep is reset and ready for a single sweep display when a trigger signal occurs. If the indicator is out when in the SGL SWP mode, the SGL SWP push button must be pressed to reset the trigger circuit.
33	SOURCE	<p>Selects the source of trigger input signal.</p> <p>STARTS AFTER DELAY (B trigger only): B sweep runs immediately after the delay time selected by the A TIME/DIV setting multiplied by the DELAY TIME POS setting. No B trigger is required. In any other B trigger SOURCE setting a trigger is required after the delay time before B sweep will run.</p> <p>NORM: Provides a trigger from the vertical deflection system. The actual source is the displayed signal. In this mode, CH 1 and CH 2 time relationship measurements are not valid and should not be used. This mode is not recommended for use in the CHOP or ALT VERT MODE because the display triggers on the channel switching transients.</p> <p>CH 1: Provides a trigger from the CH 1 preamplifier. The CH 2 display may be unstable if it is not time related to CH 1.</p> <p>CH 2: Provides a trigger from the CH 2 preamplifier. The CH 1 display may be unstable if it is not time related to CH 2.</p> <p>LINE (A trigger only): Provides a trigger from a sample of the power-line frequency. This trigger is useful when channel inputs are time related (multiple or sub-multiple) to the power-line frequency. Also, it is useful for stabilizing a display that has a power-line frequency component on a complex waveform.</p>

Table 4-2. Functions of Control, Connectors, and Indicators—Continued

Figure/index no.	Control, connector, or indicator name	Function
FO-1/33 (continued)		<p>EXT: Provides a trigger from an external signal connected to the External Trigger Input connector. This trigger input must be time related to the input signals to provide a stable display.</p> <p>EXT (\div by 10): The same as EXT above, except the input signal is attenuated by a factor of 10.</p>
34	COUPLING	<p>Selects the method used to couple signals to the trigger generator.</p> <p>AC: Selects capacitive coupling, which blocks dc components on the signal. Signals below about 60 hertz are attenuated.</p> <p>LF REJ: Selects capacitive coupling, which blocks dc components on the signal. Signals below about 50 kilohertz are rejected. Useful for displaying high frequency components of complex waveforms.</p> <p>HF REJ: Signals are capacitively coupled, which blocks the dc component. Signals below about 60 hertz and above about 50 kilohertz are attenuated. Useful for displaying low frequency components of complex waveforms.</p> <p>DC: All components of the signal are coupled. Useful for displaying low-frequency or low repetition rate signals.</p>
35	LEVEL	<p>Selects the amplitude point on the trigger signal at which the sweep is triggered. It is usually adjusted after the trigger SOURCE, COUPLING, and SLOPE have been selected.</p>
36	SLOPE	<p>Selects the slope of the trigger signal on which the sweep is triggered.</p> <p>OUT +: Sweep is triggered on the positive going portion of the trigger signal.</p> <p>IN -: Sweep is triggered on the negative going portion of the trigger signal.</p>
37	External Trigger Input Connector	<p>Connects external trigger input probe or cables to the instrument.</p>
38	A TRIGGER HOLDOFF	<p>Provides control of holdoff time between sweeps. Variable up to ten times the setting of the A TIME/DIV setting, except in the .2 and .5 second ranges. Useful when triggering on low repetition pulses or aperiodic signals.</p> <p>Obtain the best possible display using the A sweep trigger controls before setting the hold off time.</p>
39	Ground Binding Post	<p>External connector to chassis (earth) ground. The connector will accept cables or wires using open end solder lugs, banana plugs, or stripped wire for connection.</p>
40	+A GATE	<p>Provides a +5 volt positive pulse output during the A sweep time.</p>
41	+B GATE	<p>Provides a +5 volt positive pulse output during the B sweep time.</p>
42	EXT Z AXIS	<p>Connects external Z-axis inputs for crt intensity modulation. External inputs may also be used for crt blanking provided the crt intensity is properly set. Useful for adding time markers to a display, or when using the instrument as a peripheral display in a monitoring system.</p>
43	CH 2 OUT	<p>Provides an output signal from the CH 2 preamplifier. Useful for cascade operation (CH 2 into CH 1) to increase vertical deflection sensitivity. Also, may be used to trigger external equipment.</p>

4-5. OPERATING CONSIDERATIONS. To ensure optimum measurement accuracy, the following information should be considered before operating the oscilloscope.

a. Signal Connections. In general, probes offer the most convenient means of connecting an input signal to the instrument. They are shielded to prevent pickup of electrostatic interference. The 10X probe offers a high input impedance, which allows the circuit under test to perform very close to normal operation conditions. However, it also attenuates the input signal ten times.

(1) In high frequency applications that require maximum overall bandwidth, use coaxial cables terminated at both ends in their characteristic impedance. For further information, refer to the paragraph on Coaxial Cables below.

(2) High level, low frequency signals may be directly connected to the input connectors with short, unshielded leads. This coupling method works best for signals below about one kilohertz and deflection factors above one volt/division. When this method is used, establish a common ground between the instrument and the equipment under test. To avoid errors in the display, keep the leads away from any source of interference. If interference is excessive with unshielded leads, use a coaxial cable or a probe.

b. Loading Effect of Input Connections. As nearly as possible, simulate actual operating conditions in the equipment under test. Otherwise, the equipment under test may not produce a normal signal. Because of their high input impedance, the supplied probes offer the least circuit loading. When the signal is directly coupled to the input of this instrument, the input impedance is about one megohm paralleled by about 20 picofarads. When the signal is coupled to the input through a coaxial cable, the effective input capacitance depends upon the type and length of cable used. For information on obtaining maximum frequency response with coaxial cables, refer to the paragraph on Coaxial Cables below.

c. Coaxial Cables. Cables used to connect signals to the input connectors have a large effect on the accuracy of a displayed high frequency waveform.

(1) To maintain the high frequency characteristics of an applied signal, high quality, low loss coaxial cable should be used. Also, the cable should be terminated at both ends in its characteristic impedance. If it is necessary to use cables with differing characteristic impedances, use suitable impedance matching devices.

(2) To maintain fast rise time pulse characteristics, use the shortest length of coaxial cable possible. Also, observe the cable criteria for high frequency characteristics in (1) above.

d. Grounding. Reliable signal measurements cannot be made unless both the instrument and equipment under test are connected together by a common reference (ground) lead in addition to the signal lead or probe. Although the three-wire ac power cord provides a common connection with used with equipment with similar power cords, the ground loop produced may make accurate measurements impossible. The short ground lead connected to the probes provide the best signal ground. On coaxial cables, the shield provides a common ground when connected between two coaxial connectors (or with suitable adapters to provide a common ground). When using unshielded signal leads, a common ground lead should be connected from the chassis of the instrument (rear panel Ground Binding Post) to the chassis of the equipment under test.

e. Graticule. The graticule is internally marked on the faceplate of the crt to provide accurate, no parallax measurements. The graticule is marked with eight vertical and ten horizontal major divisions. Each division is one centimeter square. In addition, each major division is divided into five minor divisions. The vertical gain and horizontal timing are calibrated to the graticule, so accurate measurements can be made from the crt. Figure 4-17 shows the graticule with its various measurement markings. The terminology shown is used throughout this manual in discussions involving graticule measurements. Note the numeric scaling markings on the left side of the graticule. These are used when making rise or fall time measurements.

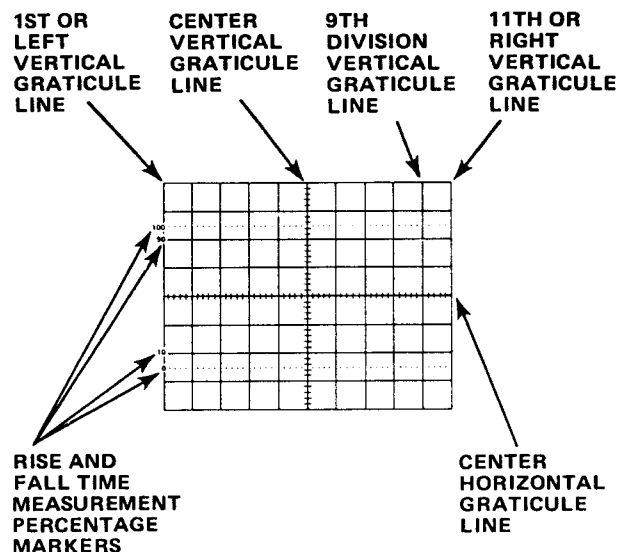

Figure 4-17 Graticule measurement markings

f. **Common Mode Rejection (Figure 4-18).** Some signals may contain undesirable components, such as in the dotted portion of Figure 4-18A. Common mode rejection can eliminate or reduce these components from the measurement. Use the following procedure to reduce or eliminate an undesirable line frequency component:

- (1) Apply signal to CH 1 input connector.
- (2) Apply line frequency signal to CH 2 input connector.
- (3) Set VERT MODE to ALT.
- (4) Push in INVERT button to invert channel 2 display.

(5) Set CH 2 VAR control to make channel 2 display amplitude about equal to undesired component of channel 1 display.

(6) Set VERT MODE to ADD and slightly readjust CH 2 VAR control for maximum rejection of undesired signal component (see Figure 4-18B).

g. **Cascaded Operation.** Maximum vertical sensitivity can be increased to approximately 1 millivolt/division by cascading the CH 1 and CH 2 amplifiers as follows:

(1) Connect CH 2 OUT signal (on rear panel) to CH 1 input via a 50 ohm cable and a 50 ohm termination.

(2) Set VERT MODE to CH 1.

(3) Apply an input signal to CH 2 input connector.

NOTE

In this mode, bandwidth is limited to about 40 megahertz.

h. **Delayed Sweep Magnification.** Following are two B Delayed modes, which may provide a higher apparent sweep rate magnification than provided by X10 MAG. First, try the Magnified Sweep Starts After Delay method. If this produces too much horizontal jitter, try the Magnified Triggered After Delay method.

(1) **Magnified Sweep Starts After Delay (Figure 4-19).** Use the following procedure to make delayed sweep magnification measurements.

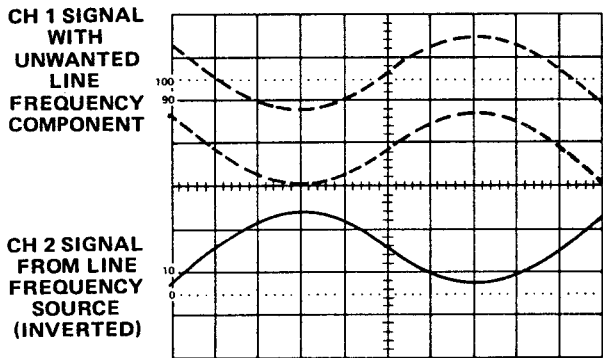

A. CH 1 AND CH 2 SIGNALS

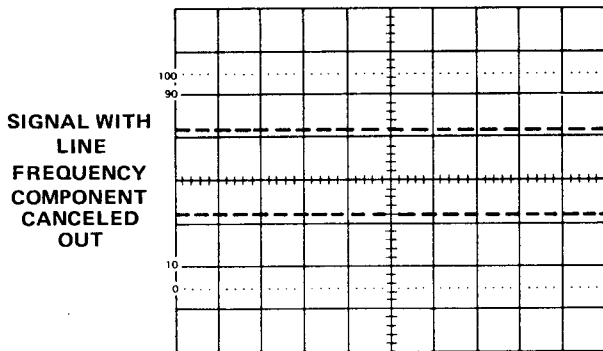

B. RESULTANT SIGNAL.

Figure 4-18. Common mode rejection of an undesired line-frequency.

(a) Set HORIZ DISPLAY to A INTEN and B SOURCE to STARTS AFTER DELAY.

(b) Use DELAY TIME POS to move the left edge of the intensified display to the left side of that portion of A sweep to be magnified.

(c) Set B TIME/DIV so just that portion of A sweep to be magnified is intensified (see Figure 4-19A).

(d) Set HORIZ DISPLAY to B DLY'D. The portion of A sweep that was intensified in (c) above is displayed in magnified form (see Figure 4-19B). The displayed sweep rate is determined by B TIME/DIV. To calculate the apparent magnification factor, use formula:

$$\text{Apparent Magnification} = \frac{\text{A TIME/DIV setting}}{\text{B TIME/DIV setting}}$$

(2) Magnified Sweep Triggered After Delay. If the Magnified Sweep Starts After Delay method above produces too much jitter, operate B sweep as follows:

(a) Perform steps (1) (a) through (1) (c) of Magnified Sweep Starts After Delay procedure above.

(b) Set B SOURCE to the same setting as A SOURCE. Set B LEVEL for a stable intensified zone.

NOTE

If the intensified zone cannot be stabilized, reset VOLTS/DIV for more display amplitude or use external triggering.

(c) Set HORIZ DISPLAY to B DLY'D. To obtain a stable display it may be necessary to slightly reset B LEVEL control.

4-6. INITIAL INSTRUMENT TURN-ON. Apply power to the instrument as follows:

a. Verify that the instrument is configured for the correct power source (refer to the Operating Voltage Selection paragraphs in Section III, Preparation for Use and Shipment).

b. Remove the power cord from the front panel cover and plug it into the rear panel connector.

c. Connect the power cord to the power source receptacle.

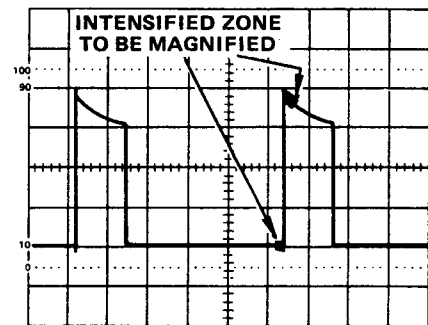

A. A INTENSIFIED DISPLAY

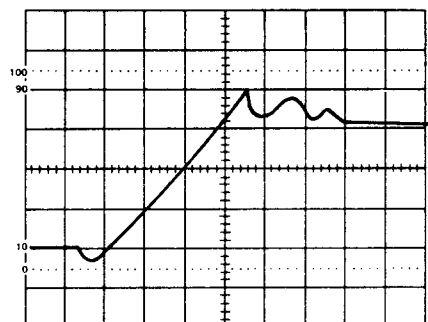

B. B DLY'D DISPLAY

Figure 4-19. Delayed sweep magnification.

d. Pull on the POWER switch. The ON indicator should light; if it blinks, the line voltage is too low.

e. Allow the instrument a few minutes to warm up (if actual measurements are to be taken, allow 5 minutes when the instrument has been stored in a temperature above 0°; 20 minutes for lower temperatures).

4-7. PRELIMINARY ADJUSTMENTS. Before using the instrument for the first time, make the following preliminary settings and adjustments, then perform a NORMAL OPERATION functional check.

a. Initial Control Settings. Set the controls as follows (both channels if applicable):

VOLTS/DIV	.2 in 10X probe window
VAR	Fully clockwise (calibrated detent)
POSITION	Midrange
AC-GND-DC	DC
VERT MODE	CH 1
INVERT	Out (normal)
20 MHz BW	In (off)
TRIG MODE	AUTO
LEVEL	Midpoint of + slope, then adjust as necessary
SLOPE	OUT +
COUPLING	AC
A SOURCE	CH 1
B SOURCE	STARTS AFTER DELAY
DELAY TIME POS	Fully counterclockwise
A and B TIME/DIV	.2 ms
A VAR	Fully clockwise (calibrated detent)
HORIZ DISPLAY	A
X10 MAG	OUT (off)
A TRIGGER HOLDOFF	NORM
SCALE ILLUM	Fully counterclockwise
POSITION, INTEN, and FOCUS	Midrange

NOTE

At this point there should be a trace displayed. If not, recheck control settings. Then press BEAM FINDER and adjust the POSITION controls so the trace is centered vertically and horizontally on the crt. If no trace appeared when BEAM FINDER was pressed, the instrument is malfunctioning. If the trace ap-

peared and could be centered, but disappeared when BEAM FINDER was released, increase the INTEN control.

b. Intensity Adjustment. Set the INTEN control for a comfortable viewing level. Later when FOCUS and ASTIG are adjusted, INTEN may need readjustment.



To protect the crt phosphor, do not turn the INTEN control higher than necessary to provide a satisfactory display. Since the blue faceplate filter reduces the display light output, avoid using too high an INTEN setting with this filter. When more intensity is desired, use the clear filter or reduce the ambient light level. The intensity may increase too high when changing the TIME/DIV settings from a fast to a slow sweep speed.

c. Focus and Astigmatism Adjustment. Adjust the FOCUS and ASTIG controls as follows:

- (1) Connect a probe to either vertical channel. Then connect the probe to the CALIBRATOR output. Set VERT MODE to the channel being used.
- (2) Adjust FOCUS so horizontal portion of display is focused.
- (3) Adjust INTEN so rising portion of the display can be seen (If display is unstable, A LEVEL may need adjustment).
- (4) Adjust ASTIG so horizontal and vertical portions of display are as equally focused as possible.
- (5) Adjust FOCUS so vertical portion of display is as thin as possible.
- (6) Repeat steps (4) and (5) for best overall display focus.
- (7) Disconnect the probe from the CALIBRATOR output.

d. Trace Rotation Adjustment. Adjust the TRACE ROTATION control as follows:

- (1) Set AC-GND-DC to GND.
- (2) Vertically position the trace to the center horizontal graticule line.

(3) Adjust TRACE ROTATION so the trace is parallel to the center horizontal graticule line.

e. Graticule Scale Illumination. To obtain scale illumination, rotate SCALE ILLUM clockwise until the desired amount of illumination is reached.

f. Probe Compensation (Figure 4-20). Each time the P6104 probes are used with the instrument, probe compensation should be checked and adjusted if necessary. A low capacitance screwdriver should be used. Use the following procedure for adjusting P6104 probe compensation:

(1) Connect P6104 probes to CH 1 and CH 2 vertical inputs.

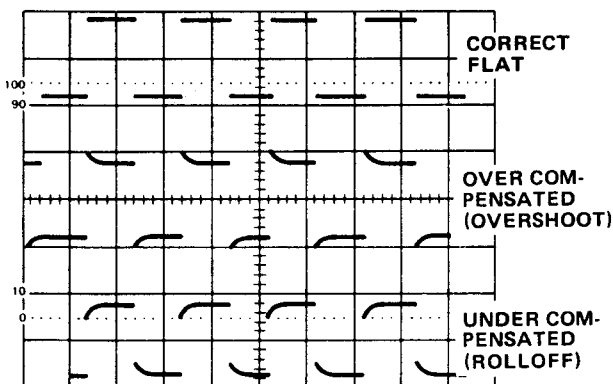
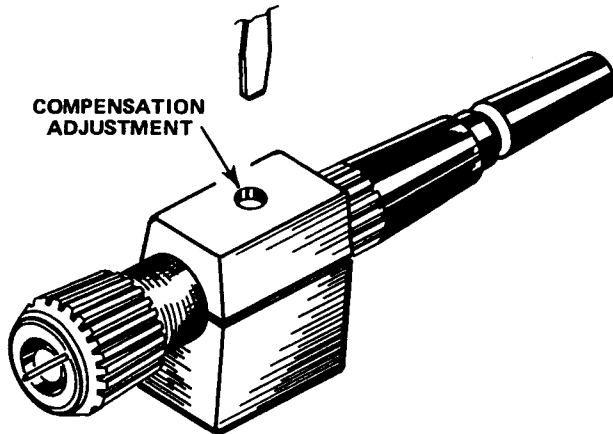

Figure 4-20. Probe compensation.

(2) Set the instrument controls as follows:

VOLTS/DIV	.2 (in 10X probe window)
A AND B TIME/DIV	.2 ms
AC-GND-DC	DC
VERT MODE	CH 1
A SOURCE	CH 1
A COUPLING	DC
HORIZ DISPLAY	A
SLOPE	OUT: +
LEVEL	Adjust as necessary for a stable display

(3) Connect the CH 1 and CH 2 probes to the CALIBRATOR. Adjust the POSITION controls so the top of at least one complete positive pulse is displayed.

(4) Adjust CH 1 probe compensation through hole in compensation box for the best flat top display.

(5) Set A SOURCE and VERT MODE to CH 2.

(6) Repeat step (4) above for CH 2.

4-8. NORMAL OPERATION. The following procedures demonstrate the operation of the controls, connectors, and indicators. These procedures may also be used for operator familiarization or as an instrument functional check. Before starting, preset the controls as listed in paragraph 4-7. a., connect probes to CH 1 and CH 2, and connect the probes to the CALIBRATOR. Where vertical channel and horizontal sweep or trigger controls are duplicated, only one set of controls is demonstrated. The procedures are intended to be preformed in the sequence listed.

a. Beam Finder. Demonstrate BEAM FINDER operation as follows:

(1) Position the CH 1 display off screen with the vertical POSITION control.

(2) Push in and hold BEAM FINDER. The display should return to on screen. Adjust POSITION to center the trace vertically and horizontally. Release BEAM FINDER. The trace should be on screen.

(3) Adjust INTEN until the display disappears.

(4) Push in and hold BEAM FINDER. The display should reappear. Release BEAM FINDER. Readjust INTEN for a visible display.

b. Intensity and Focus. Demonstrate INTEN and FOCUS operation as follows:

(1) Rotate INTEN between its maximum clockwise and counterclockwise positions. The display should vary from a blooming intensity to no display. Reset INTEN to a comfortable viewing level.

(2) Rotate FOCUS between its maximum clockwise and counterclockwise positions. The display should become blurred on either side of an optimum control setting. Reset the control for the best focused display.

c. Vertical Deflection System. Demonstrate the operation of the controls in the vertical deflection system as follows:

(1) Select CH 1 on VERT MODE. There should be one display.

(2) Rotate CH 1 POSITION between its maximum settings. The display should move off screen in both vertical directions. Reset POSITION for a visible display.

(3) Set VERT MODE to ALT. There should be two displays.

(4) Alternately rotate CH 1 and CH 2 POSITION between their maximum settings. Their respective displays should move off screen in both vertical directions. Reset POSITION for two visible displays.

(5) Set A AND B TIME/DIV to 20 ms. The CH 1 and CH 2 traces should be alternately displaying.

(6) Set VERT MODE to CHOP. The CH 1 and CH 2 traces should be simultaneously displayed. Reset A AND B TIME/DIV to 5 ms and VERT MODE to ALT.

(7) Set A SOURCE to LINE. Push in and hold TRIG VIEW. The display should be a sample of the power line trigger signal. Release TRIG VIEW and reset A SOURCE to CH 1.

(8) Set A AND B TIME/DIV to .5 ms and VOLTS/DIV to .5.

(9) Adjust vertical POSITION for one display on each side of the center horizontal graticule line. If the display is not stable, adjust A LEVEL. The display should be two vertical divisions in amplitude and each pulse width one division wide (corresponds to a one volt peak to peak, one kilohertz square wave CALIBRATOR output).

(10) Set AC-GND-DC to GND and note the position of the baseline trace. Set AC-GND-DC to AC. The display should be equally displayed on each side of the baseline trace position. Reset AC-GND-DC to DC.

(11) Adjust horizontal POSITION so the display starts at the left vertical graticule line.

(12) Push in INVERT and adjust CH 2 vertical POSITION for an on screen display. The CH 2 display should be inverted. Push in INVERT again (releases it) and readjust POSITION for separated dual displays.

(13) Rotate CH 2 VAR to its fully counterclockwise position. The UNCAL indicator should light and the display should decrease in vertical size to 0.8 divisions or less. Return VAR to its fully clockwise detent position.

(14) Set A AND B TIME/DIV to X-Y and VERT MODE to CH 2 (same as OR X-Y). The two dot display should form a 45 degree angle to the horizontal.

(15) Set CH 1 AC-GND-DC to GND. The display should be two dots in a vertical line. Reset control to DC.

(16) Set CH 2 AC-GND-DC to GND. The display should be two dots in a horizontal line. Reset control to DC.

(17) Set A AND B TIME/DIV to .5 ms and VERT MODE to ALT.

NOTE

At this point there should be a dual display with two divisions of vertical amplitude and one division pulse widths. The displays should be somewhat centered in the upper and lower halves of the screen. If not, reset the vertical deflection system controls and A AND B TIME/DIV until this display is obtained before proceeding to the horizontal deflection system procedures.

d. Horizontal Deflection System. Demonstrate the operation of the controls in the horizontal deflection system (sweep) as follows:

(1) Normal and Magnified Sweep.

(a) Set VERT MODE to CH 1.

(b) Rotate A AND B TIME/DIV one or two positions on either side of .5 ms. The display sweep rate should change. Reset A AND B TIME/DIV to .1 ms. The display pulse width should be five divisions.

(c) Rotate VAR to its fully counterclockwise position. The UNCAL indicator should light and the display pulse width should decrease to two divisions or less. Return VAR to its fully clockwise detent position.

(d) Set A AND B TIME/DIV to 1 ms and push in X10 MAG. The X10 MAG indicator should light and the display pulse width should expand to five divisions. The magnified display is the center one division (0.5 division on either side of the center vertical graticule line) of the normal display.

(e) Push in X10 MAG again (releases it).

(2) Mixed Sweep.

(a) Set A AND B TIME/DIV to .5 ms, HORIZ DISPLAY to MIXED, and DELAY TIME POS to 5.0.

(b) Pull out on the A AND B TIME/DIV outer ring, rotate B TIME/DIV to .2 ms, and release the outer ring. The display should show a sweep rate change at about the center of the display. The first five divisions of the display is at the A sweep rate and the last five divisions of the display is at the B sweep rate.

(c) Rotate DELAY TIME POS on each side of the 5.0 setting and observe the movement of the starting point of the B sweep rate portion of the display. Reset DELAY TIME POS to 5.0.

(3) A Intensified Sweep.

(a) Set HORIZ DISPLAY to A INTEN and B TIME/DIV to .1 ms. The intensified portion of the display is the B sweep time.

(b) Rotate DELAY TIME POS on either side of 5.0 and observe the movement of the intensified portion of the display.

(4) B Delayed Sweep.

(a) Set HORIZ DISPLAY to B DLY'D. The display is the intensified portion of the display seen in (3) (a) above.

(b) Rotate B TIME/DIV one position on either side of .1 ms. The display sweep rate should change. Reset B TIME/DIV to .1 ms.

(5) Normal Trigger.

(a) Set HORIZ DISPLAY to A and TRIG MODE to NORM. Rotate A LEVEL for a stable display. Adjust horizontal POSITION so display starts at the left vertical graticule line. Note that the display starts with a positive pulse.

(b) Push in A SLOPE (IN:—). Note that the display now starts with a negative pulse. Push in SLOPE again to reset it to the OUT: + position.

(6) Single Sweep Trigger.

(a) Adjust A LEVEL so display is just barely stabilized.

(b) Set A COUPLING to LF REJ.

(c) Push and release SGL SWP. The previously selected TRIG MODE should cancel.

(d) While watching the TRIG READY indicator and the display, push in and release SGL SWP. The indicator should have blinked and a display should have flashed across the screen. This indicates the trigger circuit was reset and then triggered.

(e) Disconnect the CH 1 probe tip from the CALIBRATOR and push in SGL SWP again. The TRIG READY indicator should be lit. While watching the TRIG READY indicator and the display, touch the CH 1 probe tip to the CALIBRATOR. The TRIG READY indicator should have gone out as the display flashed across the screen.

(f) Reset A COUPLING to AC and TRIG MODE to AUTO.

(g) Disconnect the probe tips from the CALIBRATOR.

(7) Low Frequency Rejection Trigger.

(a) Set A SOURCE to LINE and A AND B TIME/DIV to 10 ms.

(b) Push in and hold TRIG VIEW. The display should be a sample of the power line trigger input. Set A COUPLING to LF REJ. The display should disappear showing that the low frequency trigger rejection circuitry is working.

4-9. INSTRUMENT TURN OFF. The instrument is turned off by pushing in on the POWER push button. When turned off, the ON indicator should extinguish.

4-10. APPLICATIONS. The following information describes procedures and techniques for making specific measurements.

a. Peak to Peak Amplitude Measurement (Figure 4-21). Measure the peak to peak amplitude of a signal by multiplying the vertical deflection (in divisions) by the VOLTS/DIV setting.

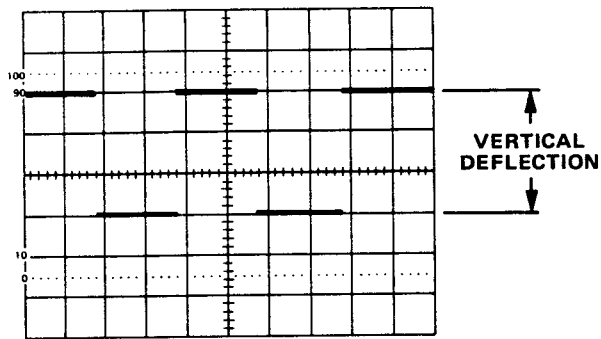

EXAMPLE:

$$\text{VERTICAL DEFLECTION} \times \text{VOLTS/DIV SETTING} = \text{AMPLITUDE}$$

$$3 \text{ DIVISIONS} \times .5 \text{ VOLTS/DIVISION} = 1.5 \text{ VOLTS PEAK-TO-PEAK}$$

Figure 4-21. Example of peak to peak voltage measurement.

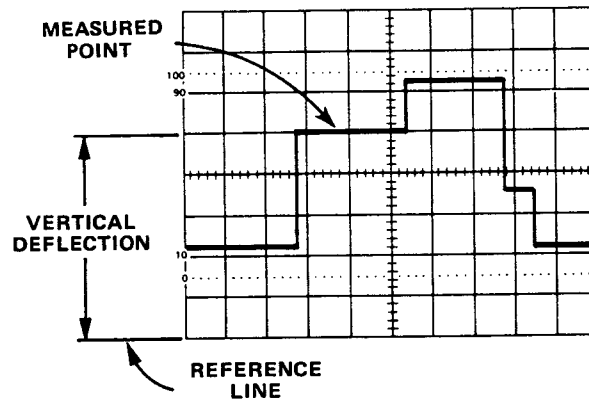

EXAMPLE:

$$\text{VERTICAL DEFLECTION FROM REFERENCE LINE TO MEASURED POINT} \times \text{VOLTS/DIV SETTING} = \text{INSTANTANEOUS AMPLITUDE}$$

$$5 \text{ DIVISIONS} \times 10 \text{ MILLIVOLTS/DIVISION} = 50 \text{ MILLIVOLTS}$$

Figure 4-22. Example of instantaneous voltage measurement.

b. Instantaneous Amplitude Measurement (Figure 4-22).

Measure the amplitude of any point on a waveform with respect to ground as follows:

- (1) Set AC-GND-DC to DC.
- (2) Apply signal to be measured to either vertical input connector. Set VERT MODE to channel being used.
- (3) Obtain a stable display.
- (4) Set AC-GND-DC to GND. Position trace to a reference line.
- (5) Set AC-GND-DC to DC. If waveform appears above reference line, voltage is positive. If waveform appears below reference line, voltage is negative.
- (6) Measure vertical difference (in divisions) between reference line and desired point on waveform and multiply by VOLTS/DIV setting.

c. Dual Trace Phase Difference Measurement (Figure 4-23).

Phase comparisons between two signals of the same frequency can be made using the dual trace feature. This method can be used up to the frequency limit of the vertical system and is usually more accurate and easier to use than the X-Y method. To make the comparison, use the following procedure:

- (1) Set both AC-GND-DC to AC.
- (2) Set VERT MODE to CHOP or ALT. (CHOP is more suitable for low frequency signals; ALT is more suitable for high frequency signals.) Position both traces to center horizontal graticule line.
- (3) Set A SOURCE to CH 1.
- (4) Connect reference signal to CH 1 input connector and comparison signal to CH 2 input connector using coaxial cables or probes which have equal time delay.
- (5) If signals are of opposite polarity, push INVERT button to invert CH 2 display. (Signals may be of opposite polarity due to 180° phase difference; if so, take this into account in final calculation.)
- (6) Set CH 1 and CH 2 VOLTS/DIV and their associated VAR controls so displays are equal and about five divisions in amplitude.
- (7) Set TIME/DIV to a sweep rate which displays about one cycle of reference waveform.
- (8) Set VAR TIME/DIV until one cycle of reference signal (CH 1) occupies exactly 8 divisions between first and ninth graticule lines.

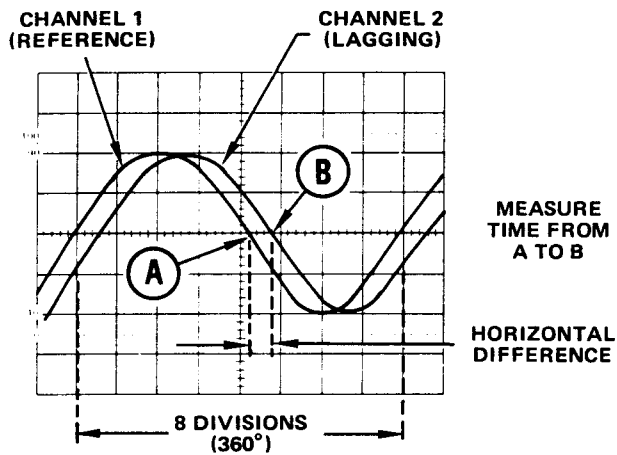

EXAMPLE:
 HORIZONTAL DIFFERENCE (A TO B) X DEGREES/DIVISION = PHASE DIFFERENCE
 0.6 DIVISION X 45°/DIVISION = 27°

Figure 4-23. Example of dual trace phase difference measurement

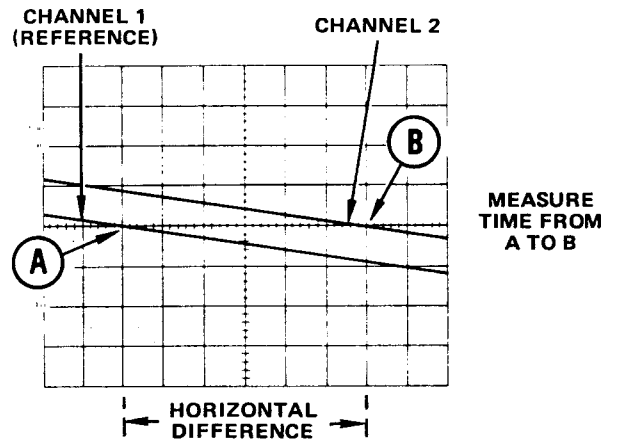

EXAMPLE:
 HORIZONTAL DIFFERENCE (A TO B) X DEGREES/DIVISION = PHASE DIFFERENCE
 6 DIVISIONS X 4.5°/DIVISION = 27°

Figure 4-24. Example of high resolution phase difference measurement.

NOTE

Each division of graticule represents 45° of cycle (360° ÷ 8 divisions = 45°/division). Therefore; the sweep rate can be stated in terms of degrees as 45°/division.

(9) Measure horizontal difference (in divisions) between corresponding points on waveforms.

(10) Multiply difference (in divisions) by 45°/division (sweep rate) to obtain exact amount of phase difference.

d. High Resolution Phase Difference Measurement (Figure 4-24). For phase differences less than 45°, measurement accuracy is increased by using X10 MAG as follows:

- (1) Perform steps (1) through (8) of 4-10 c above.
- (2) Center the measurement points on the vertical graticule line.
- (3) Push in X10 MAG. Sweep rate is now 4.5°/division (45°/division ÷ 10).
- (4) Slightly reset horizontal POSITION control to move measurement points within graticule area.
- (5) Measure horizontal difference (in divisions) between corresponding points on waveforms.

(6) Multiply difference by magnified sweep rate (4.5°/division).

e. Time Duration and Frequency Measurement (Figure 4-25). Measure the time duration between two points on a waveform by multiplying the horizontal distance (in divisions) between the points by the TIME/DIV setting. Frequency is the reciprocal of the time duration measurement of one cycle.

f. Rise Time Measurement (Figure 4-26). Rise time measurements are made in the same manner as time duration measurements, except the horizontal measurements are made between the 10% and 90% points of the waveform amplitude (see percentage markings on the left edge of the graticule) as follows:

- (1) Set VOLTS/DIV and its associated VAR control for a 5 division display.
- (2) Adjust vertical POSITION so display is between the 0% and 100% lines.
- (3) Measure horizontal distance (divisions) between 10% and 90% points on waveform (points A and B).

g. Differential Time Measurement. Differential time measurements can be made using either the A INTENS, B DLY'D, or MIXED HORIZ DISPLAY modes.

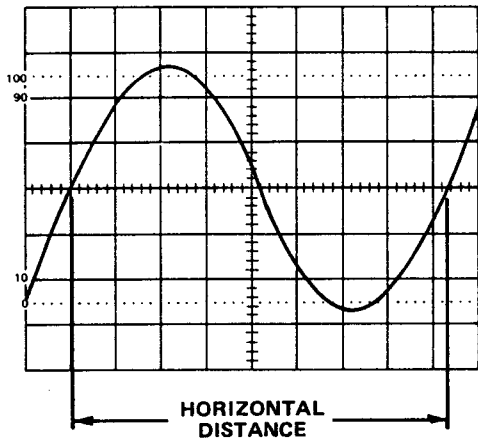

EXAMPLE:

$$\text{HORIZONTAL DISTANCE} \times \text{TIME/DIV SETTING} = \text{TIME DURATION}$$

$$8.3 \text{ DIVISIONS} \times \frac{2 \text{ MILLISECONDS}}{\text{DIVISION}} = 16.6 \text{ MILLISECONDS}$$

$$\frac{1}{\text{TIME DURATION}} = \text{FREQUENCY}$$

$$\frac{1}{16.6 \text{ MILLISECONDS}} = 60 \text{ HERTZ}$$

Figure 4-25. Example of time duration and frequency measurement

(1) **A Intensified Differential Time Measurement (Figure 4-27).** Use the following procedure to make differential time measurements using the A INTEN mode:

(a) Set A TIME/DIV and horizontal POSITION control to locate both time measurement points within graticule area.

(b) Set HORIZ DISPLAY to A INTEN and B SOURCE to STARTS AFTER DELAY.

(c) Pull out and set B TIME/DIV for the shortest useable intensified display zone.

(d) Use DELAY TIME POS control to move the left edge of intensified zone to just touch the first time measurement point (point A). Note DELAY TIME POS (1st DTP setting) setting.

(e) Use DELAY TIME POS control to move left edge of intensified zone to just touch the second time measurement point (point B). Note DELAY TIME POS (2nd DTP setting) setting.

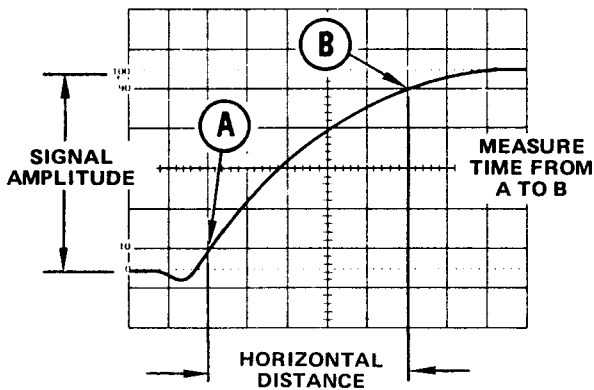

EXAMPLE:

$$\text{HORIZONTAL DISTANCE (A TO B)} \times \text{TIME/DIV SETTING} = \text{RISE TIME}$$

$$5 \text{ DIVISIONS} \times \frac{1 \text{ MICROSECOND}}{\text{DIVISION}} = 5 \text{ MICROSECONDS}$$

Figure 4-26. Example of rise time measurement.

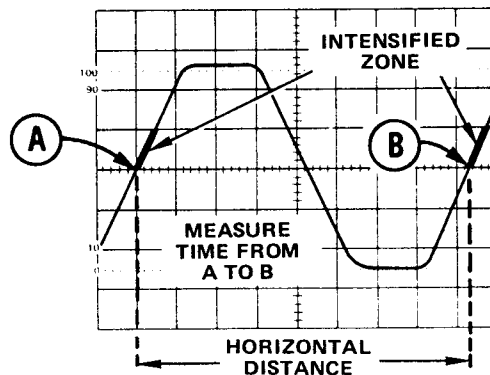

EXAMPLE:

$$\text{2ND DTP SETTING} - \text{1ST DTP SETTING} \times \frac{\text{A TIME/DIV SETTING}}{\text{B TIME/DIV SETTING}} = \text{TIME DIFFERENCE}$$

$$9.56 - 1.23 \times \frac{2 \text{ MILLISECONDS}}{\text{MILLISECONDS}} = 16.66 \text{ MILLISECONDS}$$

Figure 4-27. Example of time duration measurement using A INTEN mode.

(2) B Delayed Differential Time Measurement
(Figure 4-28). Use the following procedure to make differential time measurements using the B DLY'D mode:

- (a) Set A TIME/DIV and horizontal POSITION control to locate both time measurement points within graticule area (see Figure 4-28A).
- (b) Set HORIZ DISPLAY to A INTEN and B SOURCE to STARTS AFTER DELAY.
- (c) Pull out and set B TIME/DIV for the shortest usable intensified display zone.
- (d) Turn DELAY TIME POS so that first time measurement point (point A) is in center of intensified zone.

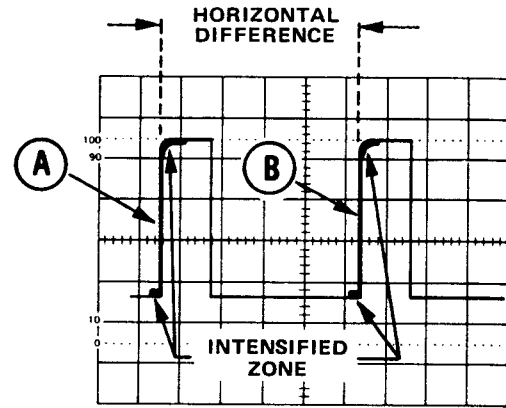

A. A INTENSIFIED DISPLAY

- (e) Set HORIZ DISPLAY to B DLY'D.
- (f) Slightly reset DELAY TIME POS to move first time measurement point to the closest vertical graticule line (see Figure 4-28B). Note DELAY TIME POS (1st DTP setting) setting.

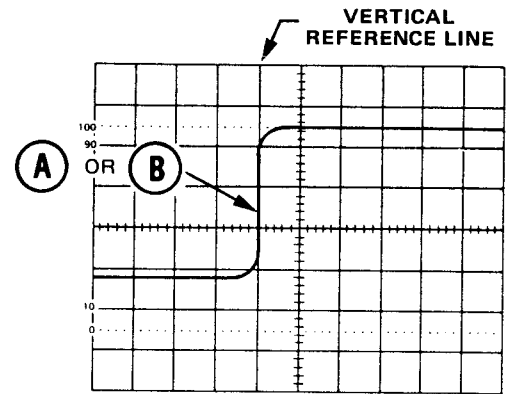

B. B DELAYED DISPLAY

- (g) Set HORIZ DISPLAY to A INTEN.
- (h) Repeat step (d) for the second time measurement point (Point B).

- (i) Set HORIZ DISPLAY to B DLY'D.
- (j) Slightly reset DELAY TIME POS to move second time measurement point to the same vertical graticule line used in step (f). Note DELAY TIME POS (2nd DTP setting) setting.

EXAMPLE:

$$\begin{array}{r}
 \text{2ND DTP} - \text{1ST DTP} \times \text{A TIME/DIV} = \text{TIME} \\
 \text{SETTING} - \text{SETTING} \times \text{SETTING} = \text{DIFFERENCE} \\
 5.57 - 0.88 \times .2 = 0.938 \\
 \text{MICROSECONDS} = \text{MILLISECONDS}
 \end{array}$$

Figure 4-28. Example of time duration measurement using B DLY'D mode.

SECTION V

MAINTENANCE INSTRUCTIONS

5-1. OPERATIONAL CHECKOUT. The operational checkout is a covers-on performance test of the AN/USM-425(V)1 using test equipment listed in Table 2-1. Satisfactory completion of the check out procedures indicates that the instrument should perform as listed in the Characteristics columns of Tables 1-1 through 1-3. Operational checkout procedures are contained in Table 5-1, which is further explained as follows:

- a. The STEP column lists the sequential steps of the procedure.
- b. The PROCEDURE column lists the instructions and illustrations used to set up and perform the test(s).
- c. The NORMAL INDICATION column lists the result that the test should produce.

d. The control settings listed in step 1 are used as initial settings for each numbered procedure. Therefore, the numbered procedures may be performed in any order by completing step 1 and step 2, then any other numbered step. This feature is useful for testing the instrument after making repairs or replacing components.



Do not connect the instrument to a power source until instructed to do so in a procedural step. This will prevent instrument damage in the event the LINE RANGE Selector has been improperly set.

Table 5-1. Operational Checkout Procedures

Step	Procedure	Normal Indication
1.	<u>Turn-on Procedure.</u>	
a.	Set instrument controls as follows (where controls are duplicated, set both the same):	
	POSITION (vertical)	Midrange
	VOLTS/DIV	5 m (1X probe window)
	VAR (VOLTS/DIV)	Fully clockwise (detent)
	AC-GND-DC	DC
	VERT MODE	CH 1
	INVERT	Out (normal)
	INTEN	Midrange
	SCALE ILLUM	Fully counterclockwise
	HORIZ DISPLAY	A
	A AND B TIME/DIV	.1 ms
	VAR (A AND B TIME/DIV)	Fully clockwise (detent)
	DELAY TIME POS	0.0
	X10 MAG	Out (off)
	A TRIGGER HOLDOFF	NORM (detent)
	LEVEL	Midrange of + side of control (adjust as necessary throughout procedure)
	SLOPE	OUT +
	COUPLING	AC
	SOURCE	NORM
	TRIG MODE	AUTO
	POSITION (horizontal)	Midrange

Table 5-1. Operational Checkout Procedures—Continued

Step	Procedure	Normal Indication
b.	Set the LINE RANGE Selector for the correct power source voltage range and check the fuse size as indicated on the instrument rear panel.	
c.	Check that the POWER switch is off.	ON indicator is not lit.
d.	Connect the power cord to the instrument and the power source.	
e.	Pull on the POWER switch. Let the instrument warm up for 5 minutes, if it was stored at or above a 0°C (+32°F) ambient temperature; otherwise, 20 minutes.	ON indicator is lit.
	<i>NOTE</i>	
	<i>For the best overall performance of the instrument, the checkout procedures should be made within an ambient temperature range of +20° to +30°C (+68° to +86°F).</i>	
2.	Preliminary Adjustments.	
a.	Adjust INTEN for a low intensity trace.	Adjustable from off to blooming.
b.	Set CH 1 AC-GND-DC to GND. Adjust FOCUS for a well defined trace.	Adjustable on either side of an optimum setting.
c.	Position the trace to the center horizontal graticule line.	Trace is parallel to the horizontal graticule line.
3.	Vertical Deflection Factor Accuracy.	
a.	Connect the equipment as follows:	
	 <p>PG 506 OR EQUIVALENT CALIBRATION GENERATOR</p> <p>AMPL OUTPUT</p> <p>DUAL-INPUT COUPLER</p> <p>50 Ω CABLE</p>	
b.	Preset controls as listed in step 1.a.	

Table 5-1. Operational Checkout Procedures—Continued

Step	Procedure		Normal Indication						
c.	Check CH 1 and CH 2 vertical deflection factors at the following settings (VERT MODE must be set to channel being tested):								
	Calibration Generator Setting	VOLTS/DIV Setting (in X1 probe window)	Vertical Display (in divisions)						
	20 mV 50 mV 0.1 V 0.2 V 0.5 V 1.0 V 2.0 V 5.0 V 10.0 V 20.0 V	5 mV 10 mV 20 mV 50 mV .1 V .2 V .5 V 1 V 2 V 5 V	3.92 to 4.08 4.90 to 5.10 4.90 to 5.10 3.92 to 4.08 4.90 to 5.10 4.90 to 5.10 3.92 to 4.08 4.90 to 5.10 4.90 to 5.10 3.92 to 4.08						
4.	<p><u>Variable Vertical Deflection Factor Range.</u></p> <p>a. Connect the equipment as shown in step 3.a.</p> <p>b. Preset controls as listed in step 1.a.; then reset CH 1 VOLTS/DIV to 10 m.</p> <p>c. Set the calibration generator to 50 mV.</p> <p>d. Rotate CH 1 VOLTS/DIV VAR fully counterclockwise.</p> <p>e. Set VERT MODE to CH 2 and CH 2 VOLTS/DIV to 10 m.</p> <p>f. Rotate CH 2 VOLTS/DIV VAR fully counterclockwise.</p> <p>g. Reset CH 1 and CH 2 VOLTS/DIV VAR fully clockwise (in detent position).</p>		<p>4.9 to 5.1 division vertical display.</p> <p>2 division or less vertical display.</p> <p>4.9 to 5.1 division vertical display.</p> <p>2 division or less vertical display.</p>						
5.	<p><u>X Gain.</u></p> <p>a. Connect the equipment as shown in step 3.a.</p> <p>b. Preset controls as listed in step 1.a.; then reset as follows:</p> <table data-bbox="407 1808 854 1892"> <tr> <td>CH 2 AC-GND-DC</td> <td>GND</td> </tr> <tr> <td>VERT MODE</td> <td>CH 2</td> </tr> <tr> <td>A AND B TIME/DIV</td> <td>X-Y</td> </tr> </table>		CH 2 AC-GND-DC	GND	VERT MODE	CH 2	A AND B TIME/DIV	X-Y	
CH 2 AC-GND-DC	GND								
VERT MODE	CH 2								
A AND B TIME/DIV	X-Y								

Table 5-1. Operational Checkout Procedures—Continued

Step	Procedure	Normal Indication
5 (continued)	c. Set the calibration generator for 20 mV (INTEN may need to be increased). d. Set CH 1 AC-GND-DC to AC.	3.88 to 1.12 division horizontal display. 3.88 to 1.12 division horizontal display.
6.	Trigger View Gain.	
a.	Connect the equipment as follows:	
<p>The diagram illustrates the connection between a PG 506 calibration generator and an oscilloscope. On the left, the generator is shown with a control knob and a large output connector labeled 'AMPL OUTPUT'. A thick black line representing a '50 Ω CABLE' connects this output to the input of the oscilloscope on the right. The oscilloscope screen shows a grid with a horizontal line, indicating the signal being received.</p>		
b.	Preset controls as listed in 1.a.; then reset as follows: CH 1 VOLTS/DIV .1 A SOURCE EXT A LEVEL 0 A AND B TIME/DIV .2 ms	
c.	Set calibration generator for 0.2 V.	
d.	Push in and hold TRIG VIEW, observe display, then release TRIG VIEW.	1.4 to 2.6 division vertical display.
e.	Set instrument controls as follows: VOLTS/DIV 1 A SOURCE EXT ÷ 10	
f.	Set calibration generator to 2 V.	
g.	Repeat step 6.d.	
7.	Channel Position Effect.	
a.	Connect the equipment as follows:	

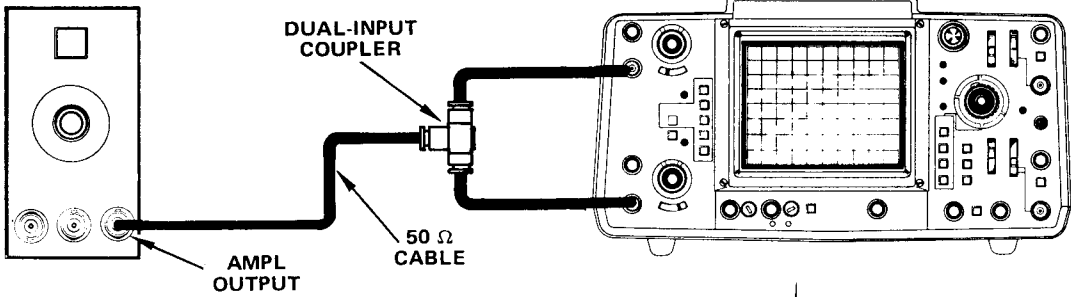
Table 5-1. Operational Checkout Procedures—Continued

Step	Procedure	Normal Indication				
7 (continued)	 <p>PG 506 OR EQUIVALENT FAST-RISE PULSE GENERATOR</p> <p>50 Ω TERMINATION</p> <p>50 Ω CABLES OF EQUAL LENGTH</p> <p>POSITIVE-GOING FAST-RISE OUTPUT</p> <p>BNC T-CONNECTOR</p> <p>50 Ω TERMINATION</p>					
b.	<p>Preset controls as listed in step 1.a.; then, reset as follows:</p> <table border="0" data-bbox="402 1003 860 1060"> <tr> <td>CH 1 VOLTS/DIV</td> <td>20 m</td> </tr> <tr> <td>A AND B TIME/DIV</td> <td>.05 μs</td> </tr> </table>	CH 1 VOLTS/DIV	20 m	A AND B TIME/DIV	.05 μ s	
CH 1 VOLTS/DIV	20 m					
A AND B TIME/DIV	.05 μ s					
c.	Set calibration generator for a 5 division display at 100 kilohertz.					
d.	Rotate CH 1 vertical POSITION to observe the top of the waveform at both the top and bottom horizontal graticule lines.	The front corner of the waveform has no more than 0.3 division peak to peak aberrations.				
e.	Set A SLOPE to IN —.					
f.	Change the calibration generator output to the negative-going fast rise output.					
g.	Repeat steps 7.c. and 7.d.					
h.	Change the calibration generator output cable from CH 1 to CH 2.					
i.	<p>Set the instrument controls as follows:</p> <table border="0" data-bbox="402 1581 852 1638"> <tr> <td>CH 2 VOLTS/DIV</td> <td>20 m</td> </tr> <tr> <td>VERT MODE</td> <td>CH 2</td> </tr> </table>	CH 2 VOLTS/DIV	20 m	VERT MODE	CH 2	
CH 2 VOLTS/DIV	20 m					
VERT MODE	CH 2					
j.	Repeat steps 7.c. and 7.d. using CH 2 vertical POSITION.					
k.	Set A SLOPE to OUT +.					
l.	Change the calibration generator output to the positive going fast rise output.					
m.	Repeat steps 7.c. and 7.d. using CH 2 vertical POSITION.					

Table 5-1. Operational Checkout Procedures—Continued

Step	Procedure	Normal Indication						
8.	Rise Time.							
a.	Connect the equipment as shown in step 7.a.							
b.	Preset controls as listed in step 1.a., then reset as follows:							
	<table border="0"> <tr> <td>A AND B TIME/DIV</td> <td>.05 μs</td> </tr> <tr> <td>CH 1 VOLTS/DIV</td> <td>20 m</td> </tr> </table>	A AND B TIME/DIV	.05 μ s	CH 1 VOLTS/DIV	20 m			
A AND B TIME/DIV	.05 μ s							
CH 1 VOLTS/DIV	20 m							
c.	Set calibration generator for a 5 division display at 1 megahertz.							
d.	Adjust vertical POSITION to place display between the 0 and 100% markers on the graticule.							
e.	Set X10 MAG to the In position (on).							
f.	Measure the time duration of the positive going portion of the display between 10 and 90% markers on the graticule	3.5 nanoseconds (0.7 division) or less.						
g.	Change the calibration generator output from CH 1 to CH 2.							
h.	Set controls as follows:							
	<table border="0"> <tr> <td>CH 2 VOLTS/DIV</td> <td>20 m</td> </tr> <tr> <td>VERT MODE</td> <td>CH 2</td> </tr> <tr> <td>X10 MAG</td> <td>Out (off)</td> </tr> </table>	CH 2 VOLTS/DIV	20 m	VERT MODE	CH 2	X10 MAG	Out (off)	
CH 2 VOLTS/DIV	20 m							
VERT MODE	CH 2							
X10 MAG	Out (off)							
i.	Repeat steps 8.c. through 8.f.							
9.	Cascaded Sensitivity and Bandwidth.							
a.	Connect the equipment as follows:							
	<p>The diagram illustrates the setup for cascaded sensitivity and bandwidth. On the left is an 'SG503 OR EQUIVALENT SINE-WAVE GENERATOR'. A '50 Ω CABLES' connects the generator to a '10X ATTENUATOR' on the scope. From the attenuator, another '50 Ω CABLES' connects to the 'FROM CH 2 OUT CONNECTOR ON REAR PANEL'. A '50 Ω TERMINATION' is also connected to this rear panel connector.</p>							
b.	Preset controls as listed in step 1.a.; then reset as follows.							
	<table border="0"> <tr> <td>VERT MODE</td> <td>CH 2</td> </tr> <tr> <td>A AND B TIME/DIV</td> <td>.2 ms</td> </tr> </table>	VERT MODE	CH 2	A AND B TIME/DIV	.2 ms			
VERT MODE	CH 2							
A AND B TIME/DIV	.2 ms							

Table 5-1. Operational Checkout Procedures—Continued

Step	Procedure	Normal Indication						
9 (continued)	c. Set sine-wave generator for a 1 division 50 kilohertz display. d. Set VERT MODE to CH 1. e. Set sine-wave generator for a 5 division display (may need to insert a 10X attenuator between 50 ohm BNC cable and 50 ohm termination). f. Set sine-wave generator to 40 megahertz.	3.5 to 6.5 division vertical display. 3.5 division or more vertical display.						
10.	Channel 1, Channel 2, and X Bandwidth.							
	a. Connect equipment as follows: <div style="text-align: center; margin: 20px 0;">  <p>The diagram illustrates the setup for step 10.a. On the left is a rectangular box labeled 'SG503 OR EQUIVALENT SINE-WAVE GENERATOR'. A thick black line representing a '50 Ω CABLE' runs from the generator to the right, where it connects to a '50 Ω TERMINATION' point on the front panel of an oscilloscope. The oscilloscope screen shows a grid with a horizontal line, indicating a signal display.</p> </div>							
	b. Preset controls as listed in step 1.a.; then reset A AND B TIME/DIV to .05 μ s c. Set sine-wave generator to 3 megahertz and adjust for a 6 division display. d. Set sine-wave generator to 100 megahertz e. Change the sine-wave generator output from CH 1 to CH 2. f. Set VERT MODE to CH 2. g. Repeat steps 10.c. and 10.d. h. Change the generator output from CH 2 to CH 1. i. Set controls as follows: <table style="width: 100%; margin-top: 10px;"> <tr> <td style="width: 50%;">A AND B TIME/DIV</td> <td style="width: 50%;">X-Y</td> </tr> <tr> <td>CH 1 POSITION</td> <td>May need adjustment for an on-screen display.</td> </tr> <tr> <td>INTEN</td> <td>May need to be increased.</td> </tr> </table>	A AND B TIME/DIV	X-Y	CH 1 POSITION	May need adjustment for an on-screen display.	INTEN	May need to be increased.	4.2 division or more vertical
A AND B TIME/DIV	X-Y							
CH 1 POSITION	May need adjustment for an on-screen display.							
INTEN	May need to be increased.							

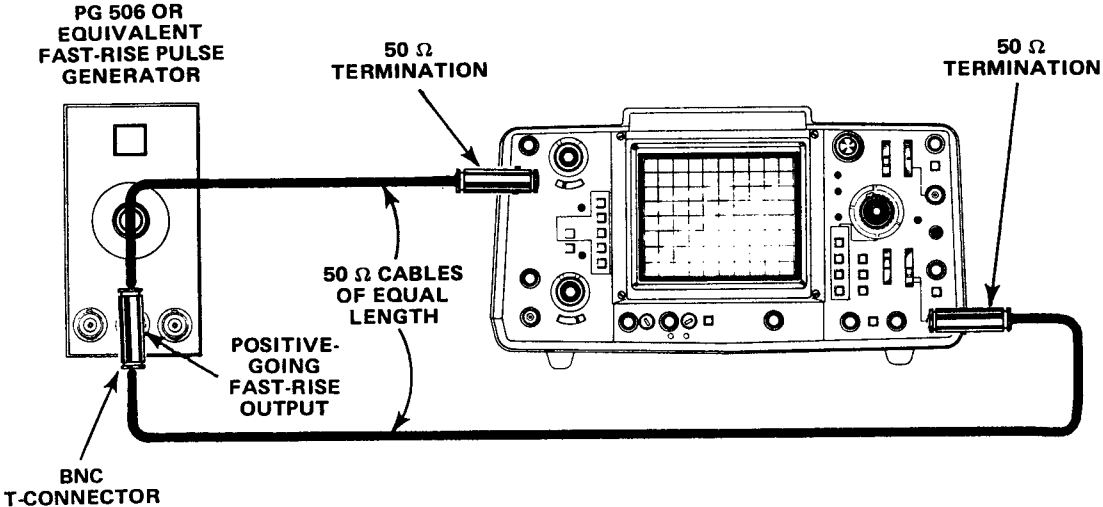
Table 5-1. Operational Checkout Procedures—Continued

Step	Procedure	Normal Indication
10 (continued)		
j.	Set sine-wave generator to 50 kilohertz and adjust for a 6 division horizontal display.	
k.	Set sine-wave generator to 4 megahertz.	4.2 division or more horizontal display.
11.	Trigger Jitter.	
a.	Connect the equipment as shown in step 10.a.	
b.	Preset controls as listed in step 1.a.; then reset as follows: A AND B TIME/DIV .05 μ s X10 MAG In (on)	
c.	Set sine-wave generator to 100 megahertz and adjust for a 3 division display.	
d.	Adjust A LEVEL for a display with minimum horizontal displacement (jitter).	0.1 division or less, plus trace width, of horizontal displacement (jitter).
e.	Set controls as follows: VERT MODE CH 2 HORIZ DISPLAY B DLY'D	
f.	Change sine-wave generator output from CH 1 to CH 2.	
g.	Repeat steps 11.c. and 11.d. using B LEVEL control.	
12.	Trigger Level Range.	
a.	Connect the equipment as shown in step 10.a.	
b.	Preset controls as listed in step 1.a.; then reset as follows: VOLTS/DIV 1 TIME/DIV 10 μ s	
c.	Set sine-wave generator to 50 kilohertz and adjust for a 4 division display.	
d.	Rotate A LEVEL between its limits.	
e.	Set A SLOPE to IN—.	The display is triggered on the positive going slope of the waveform and freeruns at either extreme setting of A LEVEL.

Table 5-1. Operational Checkout Procedures—Continued

Step	Procedure	Normal Indication								
12 (continued)	<p>f. Rotate A LEVEL between its limits.</p> <p>g. Set HORIZ DISPLAY to B DLY'D.</p> <p>h. Repeat steps 12.d. through 12.f. using B LEVEL and B SLOPE.</p>	<p>The display is triggered on the negative going slope of the waveform and free runs at either extreme setting of A LEVEL.</p> <p>The display disappears when not triggered, rather than free running.</p>								
13.	<p><u>25 MHz Triggering.</u></p> <p>a. Connect the equipment as follows:</p>  <p>b. Preset controls as listed in step 1.a.; then reset as follows:</p> <table border="0" data-bbox="422 1575 893 1711"> <tr> <td>A AND B TIME/DIV</td> <td>10 μs</td> </tr> <tr> <td>COUPLING</td> <td>DC</td> </tr> <tr> <td>SOURCE</td> <td>EXT</td> </tr> <tr> <td>VOLTS/DIV</td> <td>10 m</td> </tr> </table> <p>c. Set sine-wave generator to 50 kilohertz and adjust for a 5 division display; then set A AND B TIME/DIV to .05 μs and sine-wave generator to 25 megahertz.</p> <p>d. Rotate A LEVEL for a stable display.</p>	A AND B TIME/DIV	10 μ s	COUPLING	DC	SOURCE	EXT	VOLTS/DIV	10 m	<p>A stable display can be obtained.</p>
A AND B TIME/DIV	10 μ s									
COUPLING	DC									
SOURCE	EXT									
VOLTS/DIV	10 m									

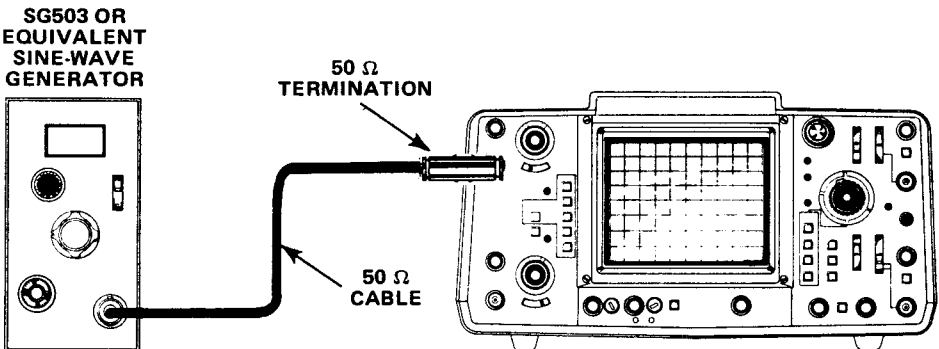
Table 5-1. Operational Checkout Procedures—Continued

Step	Procedure	Normal Indication				
13 (continued)	<p>e. Set HORIZ DISPLAY to B DLY'D</p> <p>f. Rotate B LEVEL for a stable display.</p> <p>g. Set controls as follows:</p> <table data-bbox="289 583 760 646" style="margin-left: 40px;"> <tr> <td>VOLTS/DIV</td> <td>5 m</td> </tr> <tr> <td>SOURCE</td> <td>NORM</td> </tr> </table> <p>h. Adjust sine-wave generator for a 3 division display.</p> <p>i. Set VOLTS/DIV to 50 m.</p> <p>j. Set each of the following conditions, then rotate B LEVEL to obtain a stable display:</p> <p style="text-align: center;"><i>NOTE</i></p> <p><i>When checking B Sweep control, A Trigger must be stable. To restabilize A Trigger, set HORIZ DISPLAY to A and readjust A LEVEL for a stable display. Then, reset HORIZ DISPLAY to B DLY'D and continue check.</i></p>	VOLTS/DIV	5 m	SOURCE	NORM	A stable display can be obtained.
VOLTS/DIV	5 m					
SOURCE	NORM					
B COUPLING	B SOURCE					
DC	NORM	No stable display can be obtained.				
LF REJ	NORM					
AC	NORM					
DC	CH 1					
DC	CH 2					
k.	Set TRIG MODE to NORM.					
l.	Repeat step 13.j.					
m.	Set B SLOPE to IN —.					
n.	Repeat step 13.j.					
o.	Set TRIG MODE to AUTO.					
p.	Repeat step 13.j.					
q.	Set B COUPLING to HF REJ and rotate B LEVEL between its limits.					
r.	Set HORIZ DISPLAY to A.					
s.	Repeat steps 13.j. through 13.q. using A LEVEL, A COUPLING, and A SOURCE.					

Table 5-1. Operational Checkout Procedures—Continued

Step	Procedure	Normal Indication																						
14.	<p>100 MHz Triggering.</p> <p>a. Connect equipment as shown in step 13.a.</p> <p>b. Preset controls as listed in step 1.a.; then reset as follows:</p> <table data-bbox="402 499 846 590"> <tr> <td>VOLTS/DIV</td> <td>50 m</td> </tr> <tr> <td>COUPLING</td> <td>DC</td> </tr> <tr> <td>SOURCE EXT</td> <td>EXT</td> </tr> </table> <p>c. Set sine-wave generator to 50 kilohertz and adjust output for a 3 division display; then set generator to 100 megahertz.</p> <p>d. Set controls as follows:</p> <table data-bbox="402 835 1029 898"> <tr> <td>A AND B TIME/DIV</td> <td>.05 μs</td> </tr> <tr> <td>X10 MAG</td> <td>In (on)</td> </tr> </table> <p>e. Rotate A LEVEL for a stable display.</p> <p>f. Set HORIZ DISPLAY to B DLY'D.</p> <p>g. Rotate B LEVEL for a stable display.</p> <p>h. Set SOURCE to NORM.</p> <p>i. Adjust sine-wave generator for a 1 division display.</p> <p>j. Set each of the following conditions, then rotate B LEVEL to obtain a stable display.</p> <table data-bbox="326 1276 1166 1495"> <thead> <tr> <th data-bbox="326 1276 748 1325">B COUPLING</th> <th data-bbox="748 1276 1166 1325">B SOURCE</th> </tr> </thead> <tbody> <tr> <td data-bbox="326 1325 748 1367">DC</td> <td data-bbox="748 1325 1166 1367">NORM</td> </tr> <tr> <td data-bbox="326 1367 748 1409">LF REJ</td> <td data-bbox="748 1367 1166 1409">NORM</td> </tr> <tr> <td data-bbox="326 1409 748 1451">AC</td> <td data-bbox="748 1409 1166 1451">NORM</td> </tr> <tr> <td data-bbox="326 1451 748 1493">DC</td> <td data-bbox="748 1451 1166 1493">CH 1</td> </tr> <tr> <td data-bbox="326 1493 748 1535">DC</td> <td data-bbox="748 1493 1166 1535">CH 2</td> </tr> </tbody> </table> <p>k. Set TRIG MODE to NORM.</p> <p>l. Repeat step 14.j.</p> <p>m. Set B SLOPE to IN —.</p> <p>n. Repeat step 14.j.</p> <p>o. Set TRIG MODE to AUTO.</p> <p>p. Repeat step 14.j.</p>	VOLTS/DIV	50 m	COUPLING	DC	SOURCE EXT	EXT	A AND B TIME/DIV	.05 μ s	X10 MAG	In (on)	B COUPLING	B SOURCE	DC	NORM	LF REJ	NORM	AC	NORM	DC	CH 1	DC	CH 2	<p>A stable display can be obtained.</p> <p>A stable display can be obtained.</p> <p>A stable display can be obtained.</p>
VOLTS/DIV	50 m																							
COUPLING	DC																							
SOURCE EXT	EXT																							
A AND B TIME/DIV	.05 μ s																							
X10 MAG	In (on)																							
B COUPLING	B SOURCE																							
DC	NORM																							
LF REJ	NORM																							
AC	NORM																							
DC	CH 1																							
DC	CH 2																							

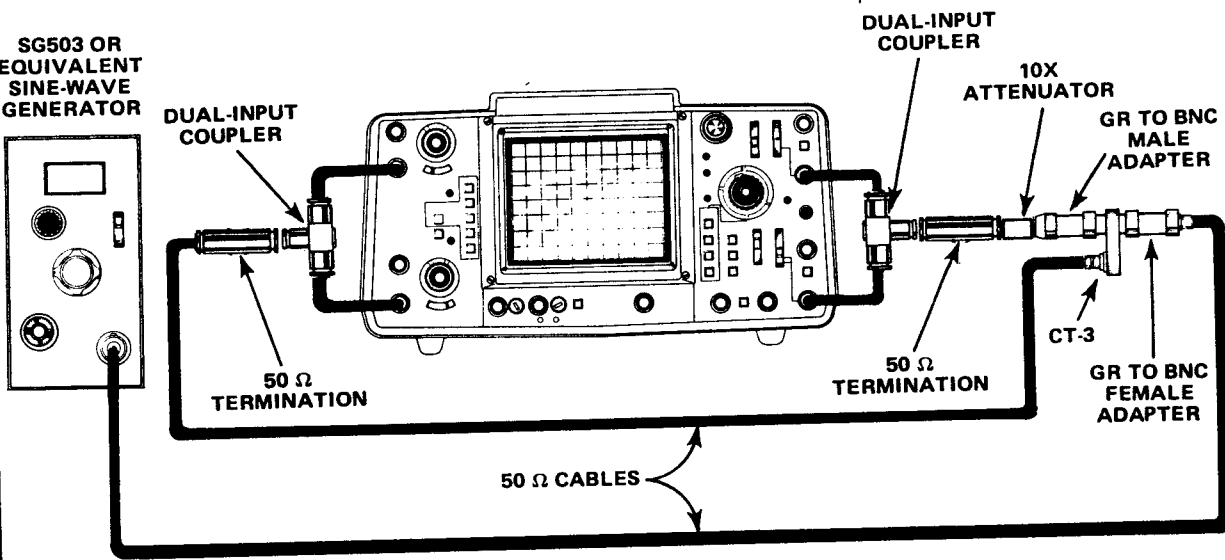
Table 5-1. Operational Checkout Procedures—Continued

Step	Procedure	Normal Indication				
14 (continued) q. r.	Set HORIZ DISPLAY to A. Repeat step 14.j. using A LEVEL, A COUPLING, and A SOURCE.					
15.	Low Frequency Trigger.					
a.	Connect equipment as follows:					
	 <p>SG 502 OR EQUIVALENT LOW-FREQUENCY GENERATOR</p> <p>DUAL-INPUT COUPLER</p> <p>50 Ω CABLES</p> <p>BNC T-CONNECTOR</p> <p>DUAL-INPUT COUPLER</p> <p>b. Preset controls as listed in step 1.a.; then reset as follows:</p> <table border="0" style="margin-left: 40px;"> <tr> <td>A AND B TIME/DIV</td> <td>10 m</td> </tr> <tr> <td>TRIG MODE</td> <td>NORM</td> </tr> </table> <p>c. Set low frequency sine-wave generator to 30 hertz and adjust for a 3 division display.</p> <p>d. Set VOLTS/DIV to 50 m.</p> <p>e. Rotate A LEVEL to obtain a stable display.</p> <p>f. Set A SLOPE to IN —.</p> <p>g. Repeat step 15.e.</p> <p>h. Set A COUPLING to LF REJ.</p> <p>i. Rotate A LEVEL between its limits.</p>	A AND B TIME/DIV	10 m	TRIG MODE	NORM	<p>A stable display can be obtained.</p> <p>No stable display can be obtained.</p>
A AND B TIME/DIV	10 m					
TRIG MODE	NORM					

Table 5-1. Operational Checkout Procedures—Continued

Step	Procedure	Normal Indication								
15 (continued)	<p>j. Set HORIZ DISPLAY to B DLY'D.</p> <p>k. Repeat steps 15.e. through 15.i. using B LEVEL, B SLOPE, and B COUPLING.</p>									
16.	<p><u>Z-Axis Input.</u></p>									
a.	<p>Connect equipment as follows:</p>									
	 <p>The diagram illustrates the setup for connecting a sine-wave generator to a test set. On the left is a rectangular box labeled "SG503 OR EQUIVALENT SINE-WAVE GENERATOR". A cable connects its output to a "T CONNECTOR". This T connector is connected to the "Z-AXIS input" on the rear panel of a test set. The test set has a screen and various control knobs. A "50 Ω CABLES" label with arrows indicates the connection between the T connector and the test set. On the right side of the test set, a "50 Ω TERMINATION" is connected to the same cable line.</p>									
b.	<p>Preset controls as listed in step 1.a.; then reset as follows:</p> <table border="0" data-bbox="397 1480 852 1602"> <tr> <td>VERT MODE</td> <td>CH 2</td> </tr> <tr> <td>CH 2 VOLTS/DIV</td> <td>1</td> </tr> <tr> <td>A AND B TIME/DIV</td> <td>.5 ms</td> </tr> <tr> <td>A SOURCE</td> <td>EXT</td> </tr> </table>	VERT MODE	CH 2	CH 2 VOLTS/DIV	1	A AND B TIME/DIV	.5 ms	A SOURCE	EXT	
VERT MODE	CH 2									
CH 2 VOLTS/DIV	1									
A AND B TIME/DIV	.5 ms									
A SOURCE	EXT									
c.	<p>Set sine-wave generator to 50 kilohertz and adjust for a 5 division display.</p>									
d.	<p>Change the sine-wave generator output (T Connector) from CH 2 to Z-AXIS input on rear panel.</p>	<p>Trace modulation is noticeable at normal intensity.</p>								

Table 5-1. Operational Checkout Procedures—Continued

Step	Procedure	Normal Indication																				
17. a.	<p>Sweep Rate Accuracy.</p> <p>Connect equipment as follows:</p>  <p>The diagram illustrates the connection for the sweep rate accuracy test. On the left is a 'TG501 OR EQUIVALENT TIME-MARK GENERATOR' with a 'MARKER OUTPUT' terminal. A '50 Ω CABLE' connects this terminal to the input of an oscilloscope. A '50 Ω TERMINATION' is connected to the other end of the cable. The oscilloscope screen shows a grid with a time mark.</p> <p>b. Preset controls as listed in step 1.a.; then reset as follows:</p> <p>CH 1 VOLTS/DIV .5 B SOURCE STARTS AFTER DELAY</p> <p>c. Check A TIME/DIV accuracy at the following settings:</p>																					
	<table border="1"> <thead> <tr> <th data-bbox="219 1459 527 1575">TIME/DIV Setting</th> <th data-bbox="527 1459 1047 1575">Time-Mark Generator Output</th> </tr> </thead> <tbody> <tr> <td>.05 μs</td> <td>50 ns</td> </tr> <tr> <td>.1 μs</td> <td>0.1 μs</td> </tr> <tr> <td>.2 μs</td> <td>0.2 μs</td> </tr> <tr> <td>.5 μs</td> <td>0.5 μs</td> </tr> <tr> <td>1 μs</td> <td>1 μs</td> </tr> <tr> <td>2 μs</td> <td>2 μs</td> </tr> <tr> <td>5 μs</td> <td>5 μs</td> </tr> <tr> <td>10 μs</td> <td>10 μs</td> </tr> <tr> <td>20 μs</td> <td>20 μs</td> </tr> </tbody> </table>	TIME/DIV Setting	Time-Mark Generator Output	.05 μ s	50 ns	.1 μ s	0.1 μ s	.2 μ s	0.2 μ s	.5 μ s	0.5 μ s	1 μ s	1 μ s	2 μ s	2 μ s	5 μ s	5 μ s	10 μ s	10 μ s	20 μ s	20 μ s	<p>1 time mark per division within 0.2 division at the 11th vertical graticule line.</p> <p>1 time mark per division within 0.2 division at the 11th vertical graticule line.</p>
TIME/DIV Setting	Time-Mark Generator Output																					
.05 μ s	50 ns																					
.1 μ s	0.1 μ s																					
.2 μ s	0.2 μ s																					
.5 μ s	0.5 μ s																					
1 μ s	1 μ s																					
2 μ s	2 μ s																					
5 μ s	5 μ s																					
10 μ s	10 μ s																					
20 μ s	20 μ s																					

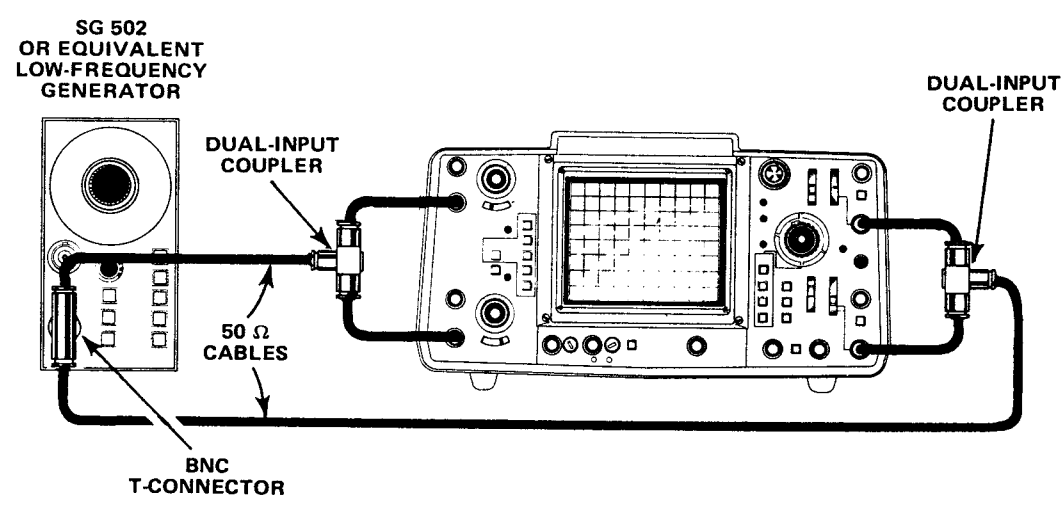
Table 5-1. Operational Checkout Procedures—Continued

Step	Procedure		Normal Indication																															
17 (continued)	<table border="1"> <thead> <tr> <th data-bbox="310 338 695 436">TIME/DIV Setting</th> <th data-bbox="699 338 1154 436">Time-Mark Generator Output</th> </tr> </thead> <tbody> <tr> <td data-bbox="310 443 695 470">50 μs</td> <td data-bbox="699 443 1154 470">50 μs</td> </tr> <tr> <td data-bbox="310 476 695 504">.1 ms</td> <td data-bbox="699 476 1154 504">0.1 ms</td> </tr> <tr> <td data-bbox="310 510 695 537">.2 ms</td> <td data-bbox="699 510 1154 537">0.1 ms</td> </tr> <tr> <td data-bbox="310 543 695 571">.5 ms</td> <td data-bbox="699 543 1154 571">0.5 ms</td> </tr> <tr> <td data-bbox="310 577 695 604">1 ms</td> <td data-bbox="699 577 1154 604">1 ms</td> </tr> <tr> <td data-bbox="310 611 695 638">2 ms</td> <td data-bbox="699 611 1154 638">2 ms</td> </tr> <tr> <td data-bbox="310 644 695 672">5 ms</td> <td data-bbox="699 644 1154 672">5 ms</td> </tr> <tr> <td data-bbox="310 678 695 705">* 10 ms</td> <td data-bbox="699 678 1154 705">10 ms</td> </tr> <tr> <td data-bbox="310 711 695 739">* 20 ms</td> <td data-bbox="699 711 1154 739">20 ms</td> </tr> <tr> <td data-bbox="310 745 695 772">* 50 ms</td> <td data-bbox="699 745 1154 772">50 ms</td> </tr> <tr> <td data-bbox="310 779 548 806">* .1 s</td> <td data-bbox="553 779 695 806">A</td> <td data-bbox="699 779 1154 806">0.1 s</td> </tr> <tr> <td data-bbox="310 812 548 840">* .2 s</td> <td data-bbox="553 812 695 840">SWEEP</td> <td data-bbox="699 812 1154 840">0.2 s</td> </tr> <tr> <td data-bbox="310 846 548 873">* .5 s</td> <td data-bbox="553 846 695 873">ONLY</td> <td data-bbox="699 846 1154 873">0.5 s</td> </tr> </tbody> </table>		TIME/DIV Setting	Time-Mark Generator Output	50 μ s	50 μ s	.1 ms	0.1 ms	.2 ms	0.1 ms	.5 ms	0.5 ms	1 ms	1 ms	2 ms	2 ms	5 ms	5 ms	* 10 ms	10 ms	* 20 ms	20 ms	* 50 ms	50 ms	* .1 s	A	0.1 s	* .2 s	SWEEP	0.2 s	* .5 s	ONLY	0.5 s	1 time mark per division within 0.2 division at the 11th vertical graticule line.
	TIME/DIV Setting	Time-Mark Generator Output																																
	50 μ s	50 μ s																																
	.1 ms	0.1 ms																																
	.2 ms	0.1 ms																																
	.5 ms	0.5 ms																																
	1 ms	1 ms																																
	2 ms	2 ms																																
	5 ms	5 ms																																
	* 10 ms	10 ms																																
* 20 ms	20 ms																																	
* 50 ms	50 ms																																	
* .1 s	A	0.1 s																																
* .2 s	SWEEP	0.2 s																																
* .5 s	ONLY	0.5 s																																
*Set TRIG MODE switch to NORM.																																		
d.	Set HORIZ DISPLAY to B DLY'D.																																	
e.	Repeat step 17.c. using B TIME/DIV.																																	
<p style="text-align: center;"><i>NOTE</i></p> <p><i>If the 11th time marker is not visible, set A TIME/DIV one position counterclockwise from B TIME/DIV (e.g., A set to 1 ms and B to .05 ms).</i></p>																																		
18.	Variable Sweep Rate Range.																																	
a.	Connect equipment as shown in step 17.a.																																	
b.	Preset controls as listed in step 1.a.; then reset as follows: <table border="0" style="margin-left: 40px;"> <tr> <td>CH 1 VOLTS/DIV</td> <td style="text-align: right;">.5</td> </tr> <tr> <td>A AND B TIME/DIV</td> <td style="text-align: right;">2 ms</td> </tr> <tr> <td>VAR TIME/DIV</td> <td style="text-align: right;">Fully counterclockwise</td> </tr> </table>		CH 1 VOLTS/DIV	.5	A AND B TIME/DIV	2 ms	VAR TIME/DIV	Fully counterclockwise																										
CH 1 VOLTS/DIV	.5																																	
A AND B TIME/DIV	2 ms																																	
VAR TIME/DIV	Fully counterclockwise																																	
c.	Set time-mark generator for 5 millisecond time marks.																																	
19.	Magnified Sweep Accuracy.																																	
a.	Connect equipment as shown in step 17.a.																																	
b.	Preset controls as listed in step 1.a.; then reset as follows: <table border="0" style="margin-left: 40px;"> <tr> <td>CH 1 VOLTS/DIV</td> <td style="text-align: right;">.5</td> </tr> <tr> <td>A AND B TIME/DIV</td> <td style="text-align: right;">.05 μs</td> </tr> </table>		CH 1 VOLTS/DIV	.5	A AND B TIME/DIV	.05 μ s																												
CH 1 VOLTS/DIV	.5																																	
A AND B TIME/DIV	.05 μ s																																	
c.	Set time-mark generator for 10 nanosecond time marks.																																	

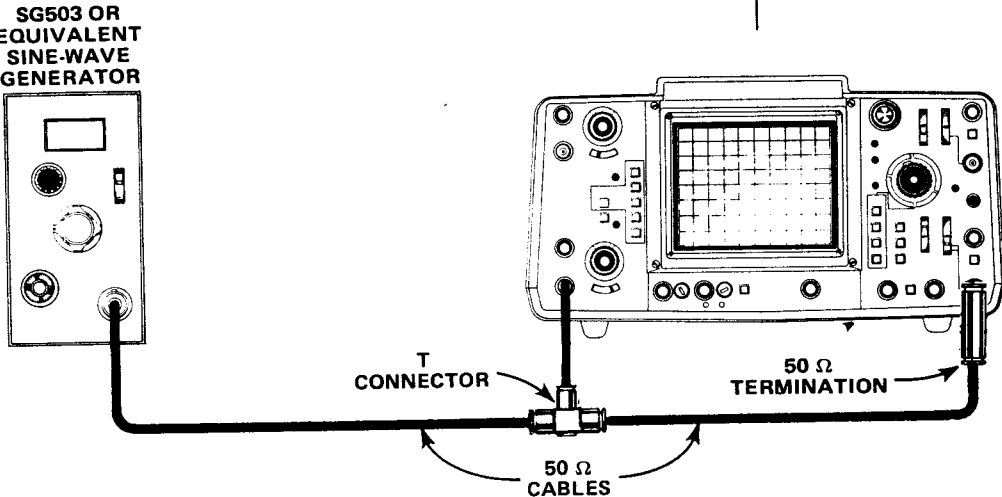
Table 5-1. Operational Checkout Procedures—Continued

Step	Procedure	Normal Indication																																																				
d. e. f.	<p>Adjust horizontal POSITION to align first time mark with the left vertical graticule line.</p> <p>Set X10 MAG to In (on).</p> <p>Check magnified A TIME/DIV accuracy at the following settings:</p> <p style="text-align: center;"><i>NOTE</i></p> <p><i>When aligning time marks with a graticule line after a new TIME/DIV selection, do not position the trace beyond alignment with the closest graticule line (see NOTE under Portion of total magnified sweep length to exclude from measurement column below).</i></p>	<p>1 time mark per division within 0.3 division at the 11th vertical graticule line; except on .05 μs setting, there is 1 time mark per two divisions.</p>																																																				
	<table border="1"> <thead> <tr> <th data-bbox="256 823 472 953">TIME/DIV Setting</th> <th data-bbox="472 823 651 953">Time-Mark Generator Setting</th> <th data-bbox="651 823 1068 953">Portion of total magnified sweep length to exclude from measurement</th> </tr> </thead> <tbody> <tr> <td data-bbox="256 953 472 1073">.05 μs</td> <td data-bbox="472 953 651 1073">10 ns</td> <td data-bbox="651 953 1068 1073" rowspan="2">First and last 50 nanoseconds</td> </tr> <tr> <td data-bbox="256 1073 472 1104">.1 μs</td> <td data-bbox="472 1073 651 1104">10 ns</td> </tr> <tr> <td data-bbox="256 1104 472 1136">.2 μs</td> <td data-bbox="472 1104 651 1136">20 ns</td> <td data-bbox="651 1073 1068 1812" rowspan="16"> <p style="text-align: center;"><i>NOTE</i></p> <p><i>To determine the excluded portion of the sweep at .05, .1, and .2 μs, position the beginning (or end) of the sweep at the left (or right) vertical graticule line. Then, horizontally POSITION the trace to the left (or right) the following number of time marks to exclude 50 ns of the sweep (be sure X10 MAG is selected): 10 time marks at .05 μs; 5 at .1 μs, or 2.5 at .2 μs.</i></p> </td> </tr> <tr> <td data-bbox="256 1136 472 1167">.5 μs</td> <td data-bbox="472 1136 651 1167">50 ns</td> </tr> <tr> <td data-bbox="256 1167 472 1199">1 μs</td> <td data-bbox="472 1167 651 1199">0.1 μs</td> </tr> <tr> <td data-bbox="256 1199 472 1230">2 μs</td> <td data-bbox="472 1199 651 1230">0.2 μs</td> </tr> <tr> <td data-bbox="256 1230 472 1262">5 μs</td> <td data-bbox="472 1230 651 1262">0.5 μs</td> </tr> <tr> <td data-bbox="256 1262 472 1293">10 μs</td> <td data-bbox="472 1262 651 1293">1 μs</td> </tr> <tr> <td data-bbox="256 1293 472 1325">20 μs</td> <td data-bbox="472 1293 651 1325">2 μs</td> </tr> <tr> <td data-bbox="256 1325 472 1356">50 μs</td> <td data-bbox="472 1325 651 1356">5 μs</td> </tr> <tr> <td data-bbox="256 1356 472 1388">.1 ms</td> <td data-bbox="472 1356 651 1388">10 μs</td> </tr> <tr> <td data-bbox="256 1388 472 1419">.2 ms</td> <td data-bbox="472 1388 651 1419">20 μs</td> </tr> <tr> <td data-bbox="256 1419 472 1451">.5 ms</td> <td data-bbox="472 1419 651 1451">50 μs</td> </tr> <tr> <td data-bbox="256 1451 472 1482">1 ms</td> <td data-bbox="472 1451 651 1482">0.1 ms</td> </tr> <tr> <td data-bbox="256 1482 472 1514">2 ms</td> <td data-bbox="472 1482 651 1514">0.2 ms</td> </tr> <tr> <td data-bbox="256 1514 472 1545">5 ms</td> <td data-bbox="472 1514 651 1545">0.5 ms</td> </tr> <tr> <td data-bbox="256 1545 472 1577">10 ms</td> <td data-bbox="472 1545 651 1577">1 ms</td> </tr> <tr> <td data-bbox="256 1577 472 1608">20 ms</td> <td data-bbox="472 1577 651 1608">2 ms</td> </tr> <tr> <td data-bbox="256 1608 472 1640">50 ms</td> <td data-bbox="472 1608 651 1640">5 ms</td> </tr> <tr> <td data-bbox="256 1640 342 1671">* .1 s</td> <td data-bbox="342 1640 472 1671">A</td> <td data-bbox="472 1640 651 1671">10 ms</td> </tr> <tr> <td data-bbox="256 1671 342 1703">* .2 s</td> <td data-bbox="342 1671 472 1703">SWEEP</td> <td data-bbox="472 1671 651 1703">20 ms</td> </tr> <tr> <td data-bbox="256 1703 342 1734">* .5 s</td> <td data-bbox="342 1703 472 1734">ONLY</td> <td data-bbox="472 1703 651 1734">50 ms</td> </tr> </tbody> </table>	TIME/DIV Setting	Time-Mark Generator Setting	Portion of total magnified sweep length to exclude from measurement	.05 μ s	10 ns	First and last 50 nanoseconds	.1 μ s	10 ns	.2 μ s	20 ns	<p style="text-align: center;"><i>NOTE</i></p> <p><i>To determine the excluded portion of the sweep at .05, .1, and .2 μs, position the beginning (or end) of the sweep at the left (or right) vertical graticule line. Then, horizontally POSITION the trace to the left (or right) the following number of time marks to exclude 50 ns of the sweep (be sure X10 MAG is selected): 10 time marks at .05 μs; 5 at .1 μs, or 2.5 at .2 μs.</i></p>	.5 μ s	50 ns	1 μ s	0.1 μ s	2 μ s	0.2 μ s	5 μ s	0.5 μ s	10 μ s	1 μ s	20 μ s	2 μ s	50 μ s	5 μ s	.1 ms	10 μ s	.2 ms	20 μ s	.5 ms	50 μ s	1 ms	0.1 ms	2 ms	0.2 ms	5 ms	0.5 ms	10 ms	1 ms	20 ms	2 ms	50 ms	5 ms	* .1 s	A	10 ms	* .2 s	SWEEP	20 ms	* .5 s	ONLY	50 ms	<p>1 time mark per division within 0.3 division at the 11th vertical graticule line except on .05 μs setting, there is 1 time mark per two divisions.</p>
TIME/DIV Setting	Time-Mark Generator Setting	Portion of total magnified sweep length to exclude from measurement																																																				
.05 μ s	10 ns	First and last 50 nanoseconds																																																				
.1 μ s	10 ns																																																					
.2 μ s	20 ns	<p style="text-align: center;"><i>NOTE</i></p> <p><i>To determine the excluded portion of the sweep at .05, .1, and .2 μs, position the beginning (or end) of the sweep at the left (or right) vertical graticule line. Then, horizontally POSITION the trace to the left (or right) the following number of time marks to exclude 50 ns of the sweep (be sure X10 MAG is selected): 10 time marks at .05 μs; 5 at .1 μs, or 2.5 at .2 μs.</i></p>																																																				
.5 μ s	50 ns																																																					
1 μ s	0.1 μ s																																																					
2 μ s	0.2 μ s																																																					
5 μ s	0.5 μ s																																																					
10 μ s	1 μ s																																																					
20 μ s	2 μ s																																																					
50 μ s	5 μ s																																																					
.1 ms	10 μ s																																																					
.2 ms	20 μ s																																																					
.5 ms	50 μ s																																																					
1 ms	0.1 ms																																																					
2 ms	0.2 ms																																																					
5 ms	0.5 ms																																																					
10 ms	1 ms																																																					
20 ms	2 ms																																																					
50 ms	5 ms																																																					
* .1 s	A	10 ms																																																				
* .2 s	SWEEP	20 ms																																																				
* .5 s	ONLY	50 ms																																																				
g.	<p>*Change TRIG MODE switch to NORM.</p> <p>Set HORIZ DISPLAY to B DLY'D.</p>																																																					

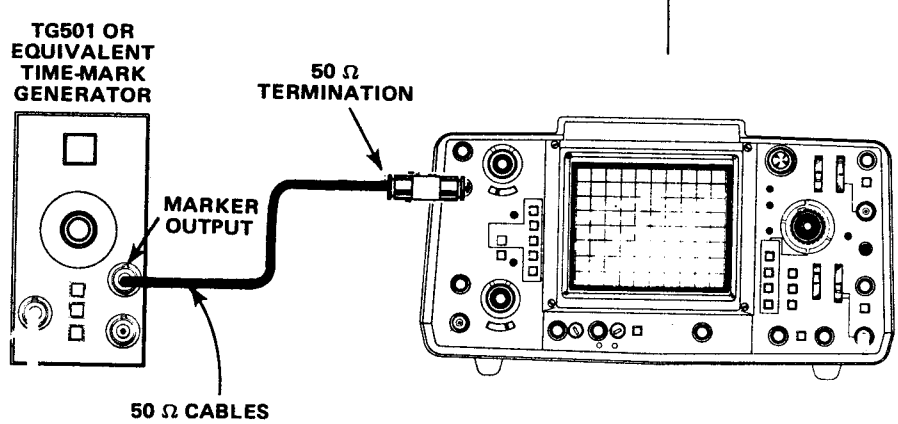
Table 5-1. Operational Checkout Procedures—Continued

Step	Procedure	Normal Indication																																																			
19 (continued)	h. Set A AND B TIME/DIV to .05 μ s. i. Repeat steps 19.c. through 19.f.																																																				
20	Differential Time Measurement Accuracy.																																																				
a.	Connect equipment as shown in step 17.a.																																																				
b.	Preset controls as listed in step 1.a.; then reset as follows:																																																				
	<table border="0" style="width: 100%;"> <tr> <td style="width: 50%;">CH 1 VOLTS/DIV</td> <td style="width: 50%;">.5</td> </tr> <tr> <td>HORIZ DISPLAY</td> <td>B DLY'D</td> </tr> <tr> <td>B SOURCE</td> <td>STARTS AFTER DELAY</td> </tr> <tr> <td>DELAY TIME POS</td> <td>1.00</td> </tr> </table>	CH 1 VOLTS/DIV	.5	HORIZ DISPLAY	B DLY'D	B SOURCE	STARTS AFTER DELAY	DELAY TIME POS	1.00																																												
CH 1 VOLTS/DIV	.5																																																				
HORIZ DISPLAY	B DLY'D																																																				
B SOURCE	STARTS AFTER DELAY																																																				
DELAY TIME POS	1.00																																																				
c.	Set time-mark generator for 0.1 microsecond time marks.																																																				
d.	Check each of the following conditions by using steps 20.e. through 20.l.																																																				
	<table border="1" style="width: 100%; text-align: center;"> <thead> <tr> <th style="width: 33%;">Time-Mark Generator Output</th> <th style="width: 33%;">A TIME/DIV Setting</th> <th style="width: 33%;">B TIME/DIV Setting</th> </tr> </thead> <tbody> <tr><td>.1 μs</td><td>.5 μs</td><td>.05 μs</td></tr> <tr><td>1 μs</td><td>1 μs</td><td>.1 μs</td></tr> <tr><td>2 μs</td><td>2 μs</td><td>.2 μs</td></tr> <tr><td>5 μs</td><td>5 μs</td><td>.5 μs</td></tr> <tr><td>10 μs</td><td>10 μs</td><td>1 μs</td></tr> <tr><td>20 μs</td><td>20 μs</td><td>2 μs</td></tr> <tr><td>50 μs</td><td>50 μs</td><td>5 μs</td></tr> <tr><td>0.1 ms</td><td>.1 ms</td><td>10 μs</td></tr> <tr><td>0.2 ms</td><td>.2 ms</td><td>20 μs</td></tr> <tr><td>0.5 ms</td><td>.5 ms</td><td>50 μs</td></tr> <tr><td>1 ms</td><td>1 ms</td><td>.1 ms</td></tr> <tr><td>2 ms</td><td>2 ms</td><td>.2 ms</td></tr> <tr><td>5 ms</td><td>5 ms</td><td>.5 ms</td></tr> <tr><td>10 ms</td><td>10 ms</td><td>1 ms</td></tr> <tr><td>20 ms</td><td>20 ms</td><td>* 2 ms</td></tr> <tr><td>50 ms</td><td>50 ms</td><td>* 5 ms</td></tr> </tbody> </table>	Time-Mark Generator Output	A TIME/DIV Setting	B TIME/DIV Setting	.1 μ s	.5 μ s	.05 μ s	1 μ s	1 μ s	.1 μ s	2 μ s	2 μ s	.2 μ s	5 μ s	5 μ s	.5 μ s	10 μ s	10 μ s	1 μ s	20 μ s	20 μ s	2 μ s	50 μ s	50 μ s	5 μ s	0.1 ms	.1 ms	10 μ s	0.2 ms	.2 ms	20 μ s	0.5 ms	.5 ms	50 μ s	1 ms	1 ms	.1 ms	2 ms	2 ms	.2 ms	5 ms	5 ms	.5 ms	10 ms	10 ms	1 ms	20 ms	20 ms	* 2 ms	50 ms	50 ms	* 5 ms	
Time-Mark Generator Output	A TIME/DIV Setting	B TIME/DIV Setting																																																			
.1 μ s	.5 μ s	.05 μ s																																																			
1 μ s	1 μ s	.1 μ s																																																			
2 μ s	2 μ s	.2 μ s																																																			
5 μ s	5 μ s	.5 μ s																																																			
10 μ s	10 μ s	1 μ s																																																			
20 μ s	20 μ s	2 μ s																																																			
50 μ s	50 μ s	5 μ s																																																			
0.1 ms	.1 ms	10 μ s																																																			
0.2 ms	.2 ms	20 μ s																																																			
0.5 ms	.5 ms	50 μ s																																																			
1 ms	1 ms	.1 ms																																																			
2 ms	2 ms	.2 ms																																																			
5 ms	5 ms	.5 ms																																																			
10 ms	10 ms	1 ms																																																			
20 ms	20 ms	* 2 ms																																																			
50 ms	50 ms	* 5 ms																																																			
	*Change TRIG MODE to NORM.																																																				
e.	Adjust horizontal POSITION to align 1st marker with the center vertical graticule line.																																																				

Table 5-1. Operational Checkout Procedures--Continued

Step	Procedure	Normal Indication
20 (continued) f. g. h. i. j. k. l.	Set DELAY TIME POS to 9.00, then adjust it to align the 1st marker with the center vertical graticule line. Select new settings from step 20.d. Set DELAY TIME POS to 9.00 Adjust horizontal POSITION to align 1st marker with the center vertical graticule line. Set DELAY TIME POS to 1.00, then adjust it to align the 1s marker with the center graticule line. Select new settings from step 20.d. Set DELAY TIME POS to 1.00 and return to step 20.e.	8.91 to 9.09 DELAY TIME POS dial reading (± 9 minor divisions). 0.91 to 1.09 DELAY TIME POS dial reading (± 9 minor divisions)
21. a. b. c. d. e. f.	<u>Delay Time Jitter.</u> Connect equipment as shown in step 17.a. Preset controls as listed in step 1.a.; then reset as follows: CH 1 VOLTS/DIV .5 A TIME/DIV 1 ms B TIME/DIV .5 μ s DELAY TIME POS 1.00 HORIZ DISPLAY B DLY'D B SOURCE STARTS AFTER DELAY INTEN Visible display Set time-mark generator for 1 millisecond time marks. Very slightly adjust DELAY TIME POS until leading edge of waveform is visible Set DELAY TIME POS to 9.00. Repeat step 21.d.	1 division or less horizontal displacement (jitter) of waveform leading edge.
22. a.	<u>Mixed Sweep Accuracy.</u> Connect equipment as shown in step 17.a.	

Table 5-1. Operational Checkout Procedures—Continued

Step	Procedure	Normal Indication
22. (continued)		
b.	Preset controls as listed in step 1.a.; then reset as follows: B SOURCE STARTS AFTER DELAY HORIZ DISPLAY MIXED VOLTS/DIV .5 A TIME/DIV 1 ms B TIME/DIV .1 ms DELAY TIME POS Fully Clockwise	
c.	Set time-mark generator for 1 millisecond time marks.	
d.	Adjust horizontal POSITION to align 1st time mark with the left vertical graticule line.	1 time mark per division within 0.36 division over the first nine divisions.
e.	Set DELAY TIME POS fully counterclockwise.	
f.	Set time-mark generator for 0.1 millisecond time marks.	
g.	Adjust horizontal POSITION to align the first time mark with the left vertical graticule line.	1 time mark per division within 0.18 division over the last nine divisions.
h.	Set controls as follows: A TIME/DIV .5 μ s B TIME/DIV .05 μ s	
i.	Set time-mark generator for 50 nanosecond time marks.	
j.	Adjust horizontal POSITION to align the first time mark with the left vertical graticule line.	1 time mark per division within 0.18 division over the last nine divisions.
k.	Set DELAY TIME POS fully clockwise.	
l.	Set time-mark generator for 0.5 microsecond time marks.	
m.	Adjust horizontal POSITION to align the first time mark with the left vertical graticule line.	1 time mark per division within 0.36 division over the first nine divisions.
23.	<u>+Gate Outputs and A Trigger Holdoff.</u>	
a.	Preset controls as listed in step 1.a.; then reset A AND B TIME/DIV to 2 μ s.	
b.	Connect a monitor oscilloscope to the +A GATE output on the rear panel with a 50 ohm BNC cable and set its TIME/DIV to 5 μ s.	5 volt positive pulse within 0.5 volt.
c.	Set oscilloscope under test A AND B TIME/DIV to 5 μ s.	
d.	Set monitor oscilloscope TIME/DIV to 20 μ s.	

Table 5-1. Operational Checkout Procedures—Continued

Step	Procedure	Normal Indication
e.	Adjust monitor oscilloscope VAR TIME/DIV so the negative portion of the pulse is 1 division wide.	Negative portion of pulse width expands to 3 divisions or more.
f.	Rotate oscilloscope under test A TRIGGER HOLDOFF fully clockwise.	
g.	Rotate oscilloscope under test A TRIGGER HOLDOFF fully counter-clockwise into the NORM detent.	
h.	Set monitor oscilloscope VAR TIME/DIV to its calibrated detent.	
i.	Set controls as follows: HORIZ DISPLAY B DLY'D B SOURCE STARTS AFTER DELAY A AND B TIME/DIV 2 μ s	
j.	Change monitor oscilloscope input from +A GATE to +B GATE on oscilloscope under test.	5 volt positive pulse within 0.5 volt.
24.	Chopped Mode Repetition Rate.	3.33 to 5 division between the start of each complete wave cycle of the display.
a.	Preset controls as listed in step 1.a.; then reset as follows: A AND B TIME/DIV 1 μ s VERT MODE CHOP A LEVEL Stable display	
25.	Calibrator Output.	Square wave of 2 divisions peak to peak at 1 kilohertz within 0.1 kilohertz (a period of 1.8 to 2.2 divisions).
a.	Connect CH 1 input to the CALIBRATOR with a probe.	
b.	Preset the controls as listed in step 1.a.; then reset as follows: CH 1 AC-GND-DC DC VOLTS/DIV .5 A AND B TIME/DIV 1 ms	

5-2. PREVENTIVE MAINTENANCE. Operator preventive maintenance consists of external inspection and cleaning. Instrument repair agency preventive maintenance consists of external and internal inspection, cleaning, and lubrication. When performed regularly, preventive maintenance can prevent instrument breakdown and improve reliability.

a. Preventive Maintenance Schedule. Preventive maintenance schedules are usually established by a combination of user policies, equipment uses, and equipment environmental conditions. Lacking this guidance, Table 5-2 is a re-

commended preventive maintenance schedule for instruments in continuous use.

Table 5-2. Preventive Maintenance Schedule

	As required	Monthly	Semiannual or 1000 instrument hours
External cleaning	X		
External inspection		X	
Internal cleaning			X
Internal inspection			X
Calibration			X

b. External Preventive Maintenance. The following instructions are intended for use by either operators or the instrument repair agency.

(1) External Inspection. Table 5-3 is a list of external items to be inspected for damage or wear. Coordinate with the repair agency for repair of items that would cause serious or further damage to the instrument if not repaired immediately.



Instruments that appear to have been dropped, or otherwise abused, should be checked by qualified instrument repair technicians to verify correct operation and calibration.

(2) External Cleaning, Except Crt Faceplate and Filter. Dust the exterior surfaces with a dry, lint free cloth or a soft bristle brush. If hard dirt remains, use a cloth or swab dampened with warm water and a mild detergent. A small swab is useful for cleaning in narrow spaces and around controls.



To prevent getting water inside the instrument during external cleaning, use only enough water to dampen the cloth or swab.

Do not use chemical cleaning agents as they may damage the plastics used in the instrument. Use only approved cleaning agents.

(3) Cleaning the Crt Faceplate and Filter. To clean the crt faceplate and light filter, remove the filter as shown in Figure 3-1. Clean the faceplate and filter with a soft, lint free cloth dampened with isopropyl alcohol.

Table 5-3. External Inspection Checklist

Item	Inspect for	Repair action (by repair agency unless otherwise noted)
Cabinet, front-panel cover, front panel, and rear panel	Cracks, scratches, deformations, and damaged hardware or gaskets.	Touch-up paint scratches (user). Replace cracked, deformed, or damaged parts.
Carrying handle	Correct operation.	Replace damaged parts.
Accessories	Missing items or parts of items, bent pins, broken or frayed cables, damaged connectors.	Repair frayed cables (user). Replace damaged or missing items (user). Repair damaged parts.
Front panel controls	Missing, damaged, or loose knobs or push buttons. Binding controls.	Tighten loose knobs (user). Repair or replace missing or damaged controls. Determine cause of binding controls, and repair.
Connectors	Broken shells, cracked insulation, and deformed contacts. Dirt in connector.	Replace damaged parts. Clean or wash out dirt (user).

c. Internal Preventive Maintenance. The following instructions are intended for use by instrument repair agencies only. When this maintenance is performed, that maintenance under External Preventive Maintenance above should also be performed.

WARNING

Electric shock hazards inside the instrument are exposed when the cabinet is removed. Disconnect the instrument from any power source before removing the covers.

(1) Cabinet Removal. Refer to Component Removal and Replacement for instructions on cabinet removal.

(2) Internal Cleaning. Internal cleaning should be done with a dry, low velocity stream of air. A soft bristle brush or swab is useful for cleaning in narrow spaces or around components. If these methods do not remove all the dust or dirt, the instrument may need to be disassembled and washed. Components may be spray washed using a 5% solution of water and mild detergent as follows:

CAUTION

Do not disassemble or wash the TIME/DIV switch and its associated circuit boards. Also, do not wash the vertical attenuators and their circuit boards. Washing may leave a residue on the switch contacts causing intermittent electrical problems.

When washing near unsealed electromechanical components, such as push-button switches use as little washing action as possible. This is to prevent washing all of the lubricant out of the part.

Do not use fluorocarbon base spray cleaners or silicone spray lubricants on cam switches or push-button switches. These sprays may damage the circuit board material or plastic parts and leave a dust collecting residue.

- (a) Remove easily accessible shields and covers.
- (b) Spray wash and thoroughly rinse the component.
- (c) Blow-dry the component with low velocity air.
- (d) Spray all switch contacts with isopropyl alcohol, wait for 60 seconds, and blow dry with low velocity air.
- (e) Heat dry all components in an oven or compartment using low temperature (125° to 150° F) circulating air.

(3) TIME/DIV Switch Cleaning. This switch should not need cleaning unless it is intermittent. If so, rotate the switch between its limits a few times to see if it will self clean. If this doesn't work, spray the contact area with isopropyl alcohol, wait for 60 seconds, and blow dry with low velocity air. If these two methods do not solve the problem, remove the A AND B Timing Switch Board Assembly and disassemble it. Cleaning instructions are contained in the disassembly instructions.

(4) Attenuator Cleaning. The attenuator cam switches should be cleaned like the TIME/DIV switch above. If this doesn't work, disassemble the attenuator and clean the switch pads with an eraser (soft type on a pencil). See Component Removal, Replacement, and Disassembly instructions.

(5) Internal Inspection. Inspect the instrument for internal damage or wear using Table 5-4. Also, inspect externally using Table 5-3.

(6) Lubrication. Components are factory lubricated, which should be adequate for the life of the instrument. Occasionally, a replacement part in an assembly, such as a cam switch, may need lubricating. Where necessary, lubrication instructions are included in the Component Removal and Replacement instructions.

5-3. TROUBLESHOOTING. The following information is provided for troubleshooting the instrument. An understanding of the Theory of Operation in Section IV may be helpful in location of troubles.

Table 5-4. Internal Inspection Checklist

Item	Inspect for	Repair action
Circuit boards	Loose, broken, or corroded solder connections. Burned circuit boards, Burned, broken, or cracked circuit run plating.	Clean solder corrosion with an eraser and flush with isopropyl alcohol. Resolder connections. Determine cause of burned items, and repair. Repair damaged circuit runs.
Chassis	Dents, deformation, and damaged hardware.	Straighten, repair, or replace damaged hardware.
Resistors	Burned, cracked, broken, or blistered.	Replace damaged resistors.
Solder Connections	Cold solder or rosin joints.	Resolder and clean joint with isopropyl alcohol.
Wiring and Cables	Loose plugs or connectors. Burned, broken, or frayed.	Firmly seat connectors. Repair or replace damaged wire or cables.
Capacitors	Damaged or leaking cases. Corroded solder on terminals or leads.	Replace capacitors with damaged or leaking cases. Clean solder connections and flush with isopropyl alcohol.
Semiconductors	Loosely inserted in sockets. Bent pins.	Remove items with bent pins, carefully straighten the pins with long-nose pliers, and reinsert firmly (be sure that the straightening action hasn't cracked the pin such that it will break easily). Firmly seat all loose semiconductors.
Push-button controls	Binding controls. Missing push buttons.	Determine cause of binding control, and repair. Replace push buttons.

a. Troubleshooting Aids.

(1) **Diagrams.** Complete circuit diagrams are contained on foldout pages in Section VI, Diagrams. The portions of the circuit mounted on circuit boards are enclosed with heavy lines. The component number and electrical value of each component in this instrument are shown on the diagrams (see the Diagrams section for symbols used on diagrams). Each main circuit is assigned a series of component numbers to assist in identifying their circuit location. Important voltages and waveforms are also shown on the diagrams. The physical locations of the waveform test points are shown on the circuit board illustrations.

(2) **Circuit Board Illustrations.** Each circuit diagram has an associated circuit board illustration located on the back of the pullout page opposite the circuit diagram. Each

circuit component shown on the circuit diagram is identified on the circuit board illustration by its circuit number. Circuit number locations are identified with a grid index system.

(3) **Component Value Identification.** Values of capacitors, diodes and resistors used in this instrument are identified by direct numerical values or by a color code scheme. Figure 5-1 shows the color code and numerical value schemes used.

(4) **Troubleshooting Chart.** A troubleshooting chart Figure 5-2, is provided to aid in locating problem areas.

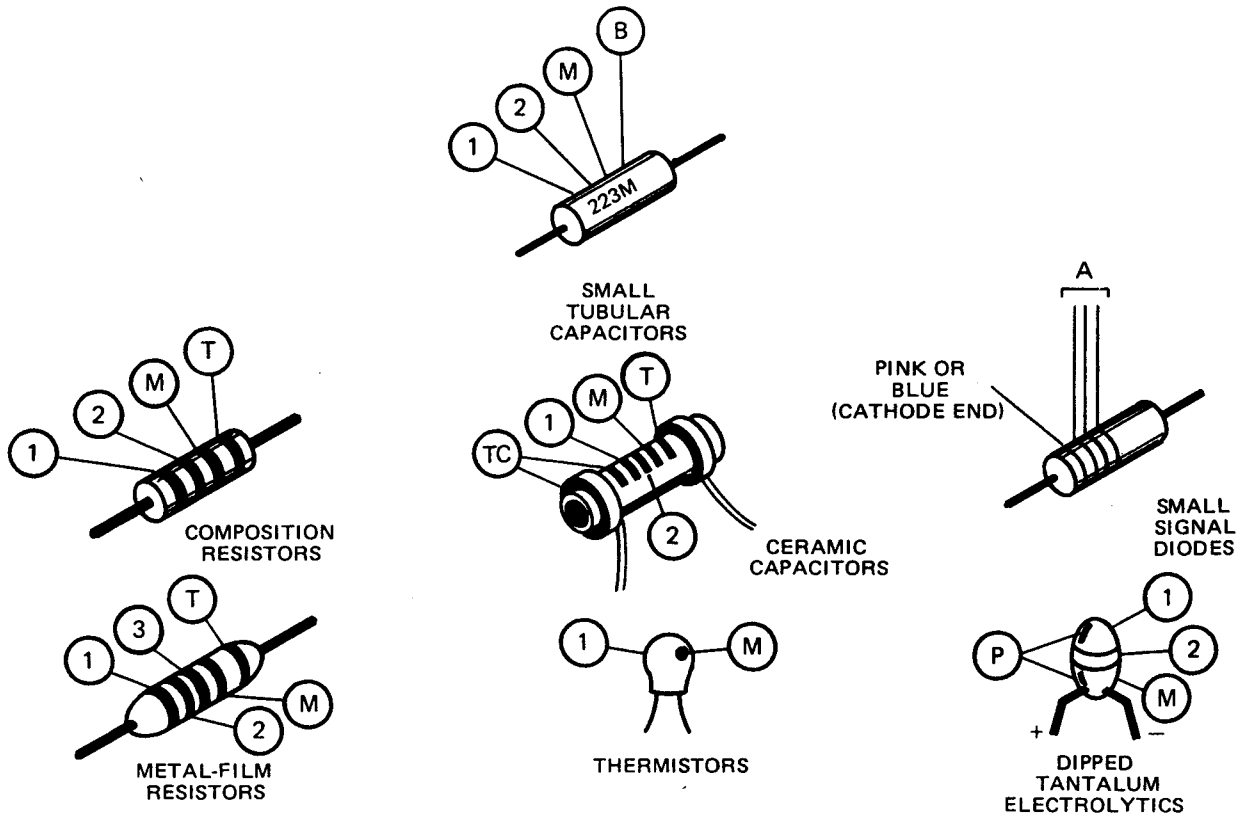

- (A) COLORS IDENTIFY SIGNIFICANT DIGITS IN TEKTRONIX PART NUMBER (E.G. BROWN, GRAY, GREEN STRIPES INDICATE PART NUMBER 152-0185-00)
- (B) TOLERANCE; F=±1%, J=5%, K=10%, M=20%
- (1) (2) and (3) 1ST, 2ND, AND 3RD SIGNIFICANT FIGS.
- (M) MULTIPLIER (T) TOLERANCE;
- (TC) TEMPERATURE COEFFICIENT.
- (T) AND/OR (TC) COLOR CODE MAY NOT BE PRESENT ON SOME CAPACITORS;
- (P) POLARITY AND VOLTAGE RATING

COLOR	SIGNIFICANT FIGURES	RESISTORS (Ω)		CAPACITORS (μF)			DIPPED TANTALUM VOLTAGE RATING
		MULTIPLIER	TOLERANCE	MULTIPLIER	TOLERANCE		
					over 10 μF	under 10 μF	
BLACK	0	1	----	1	±20%	±2 μF	4 VDC
BROWN	1	10	±1%	10	±1%	±0.1 μF	6 VDC
RED	2	10^2 or 100	±2%	10^2 or 100	±2%	----	10 VDC
ORANGE	3	10^3 or 1 K	±3%	10^3 or 1000	±3%	----	15 VDC
YELLOW	4	10^4 or 10 K	±4%	10^4 or 10,000	+100% -9%	----	20 VDC
GREEN	5	10^5 or 100 K	±½%	10^5 or 100,000	±5%	±0.5 μF	25 VDC
BLUE	6	10^6 or 1 M	±¼%	10^6 or 1,000,000	----	----	35 VDC
VIOLET	7	----	±1/10%	----	----	----	50 VDC
GRAY	8	----	----	10^{-2} or 0.01	+80% -20%	±0.25 μF	----
WHITE	9	----	----	10^{-1} or 0.1	±10%	±1 μF	3 VDC
GOLD	-	10^{-1} or 0.1	±5%	----	----	----	----
SILVER	-	10^{-1} or 0.01	±10%	----	----	----	----
NONE	-	----	±20%	----	±10%	±1 μF	----

Figure 5-1. Component value identification.

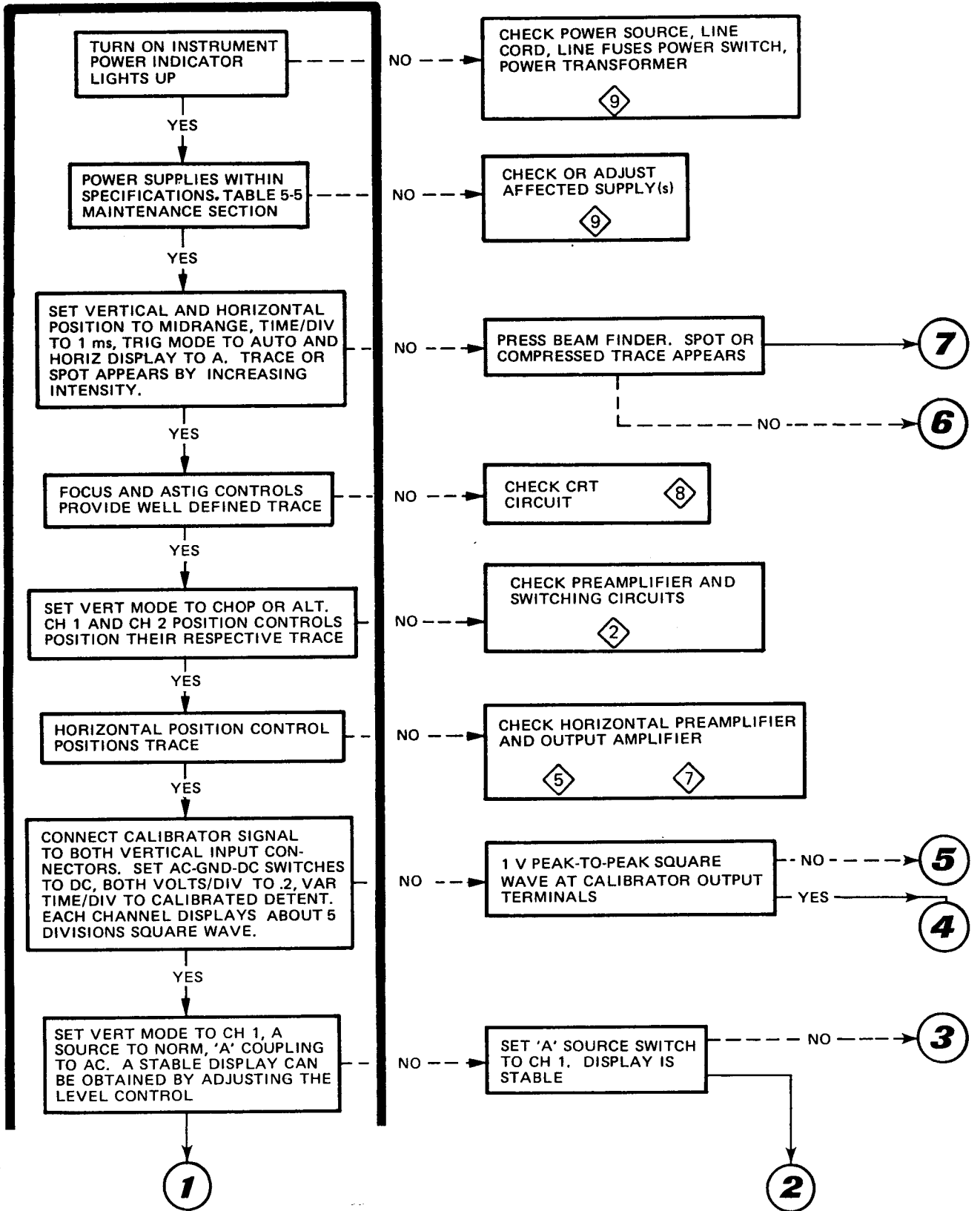

Figure 5-2. Troubleshooting chart (sheet 1 of 5).

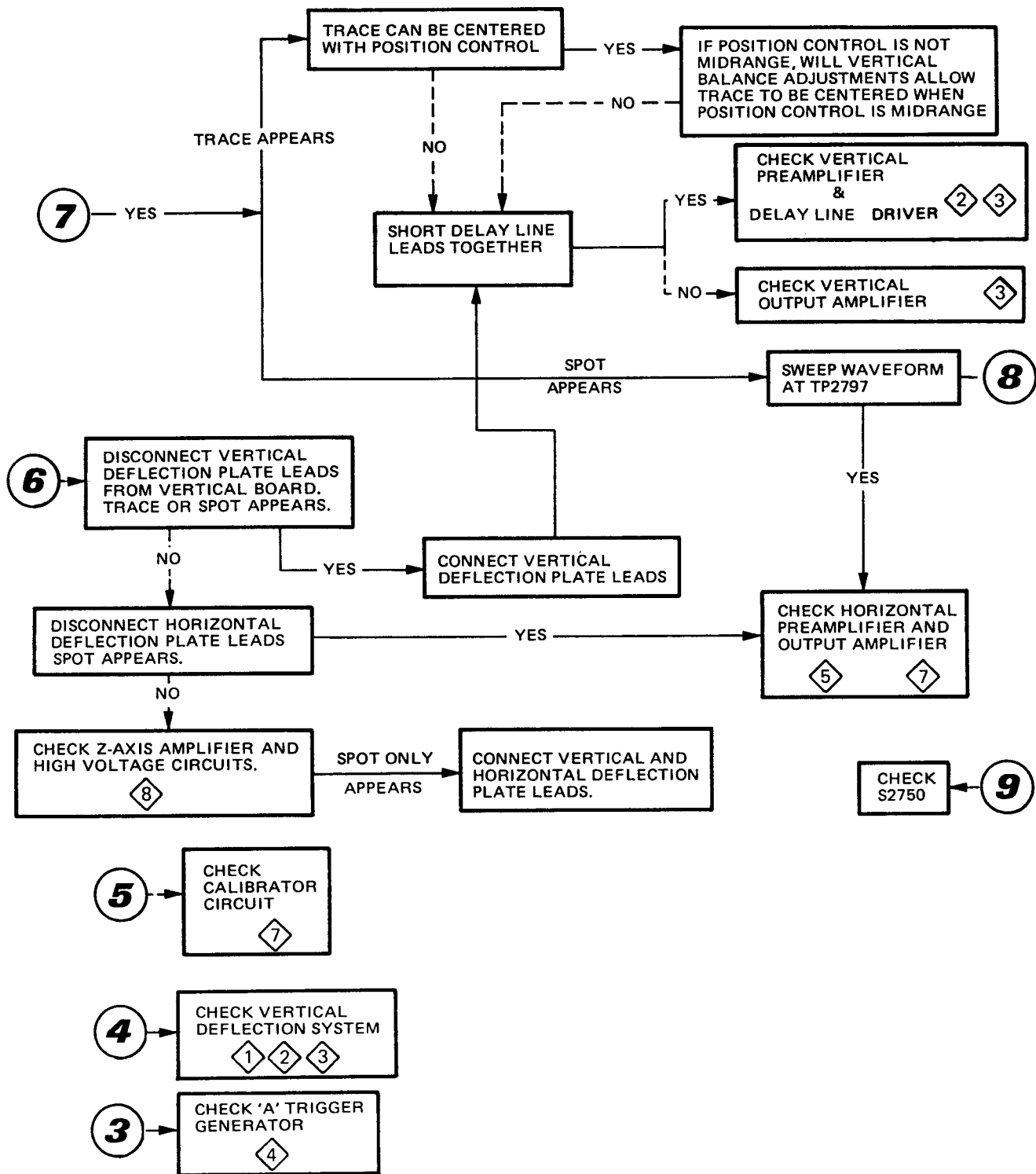

Figure 5-2. Troubleshooting chart (sheet 2 of 5).

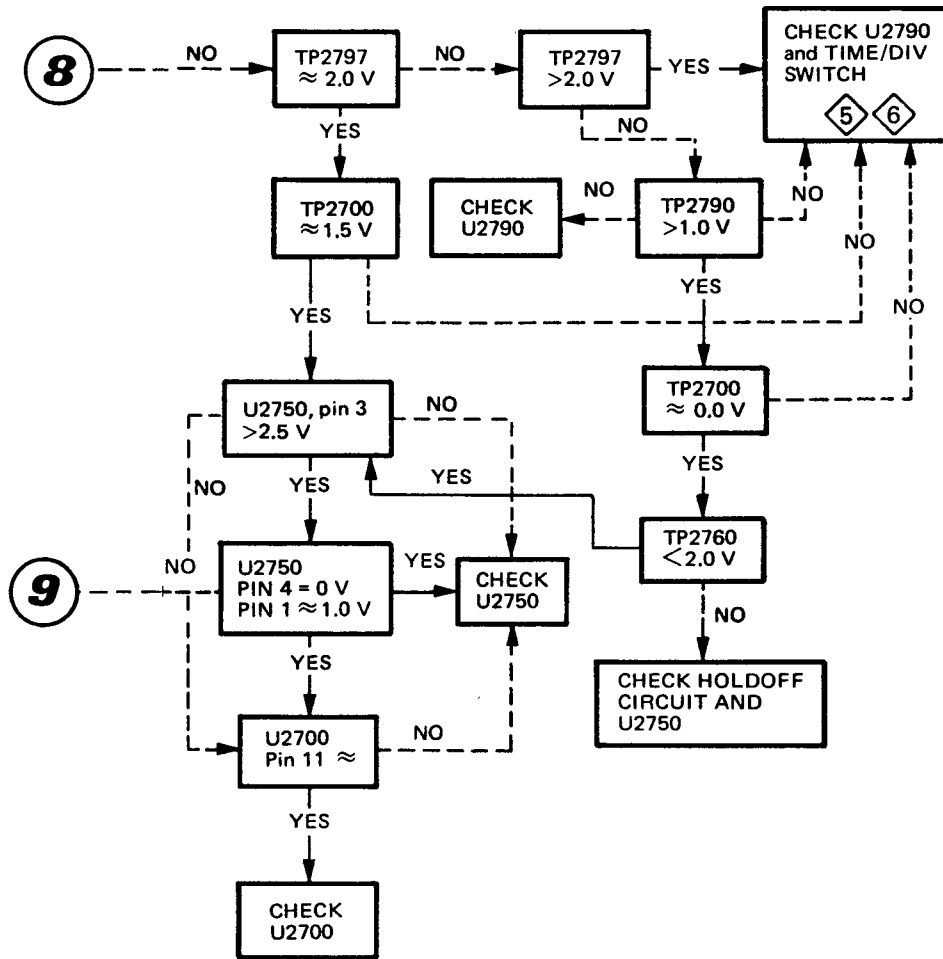

Figure 5-2. Troubleshooting chart (sheet 3 of 5).

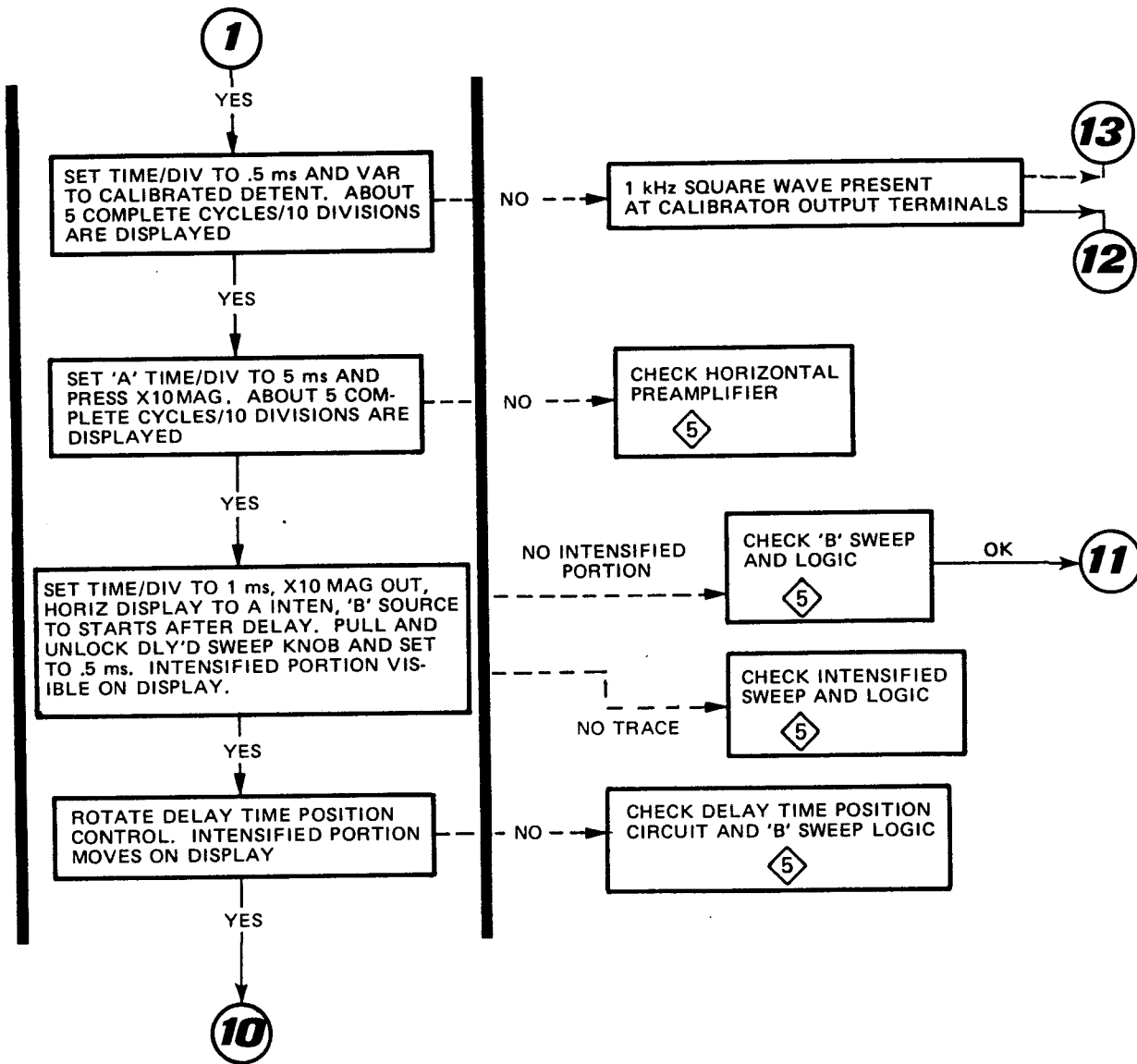

Figure 5-2. Troubleshooting chart (sheet 4 of 5).

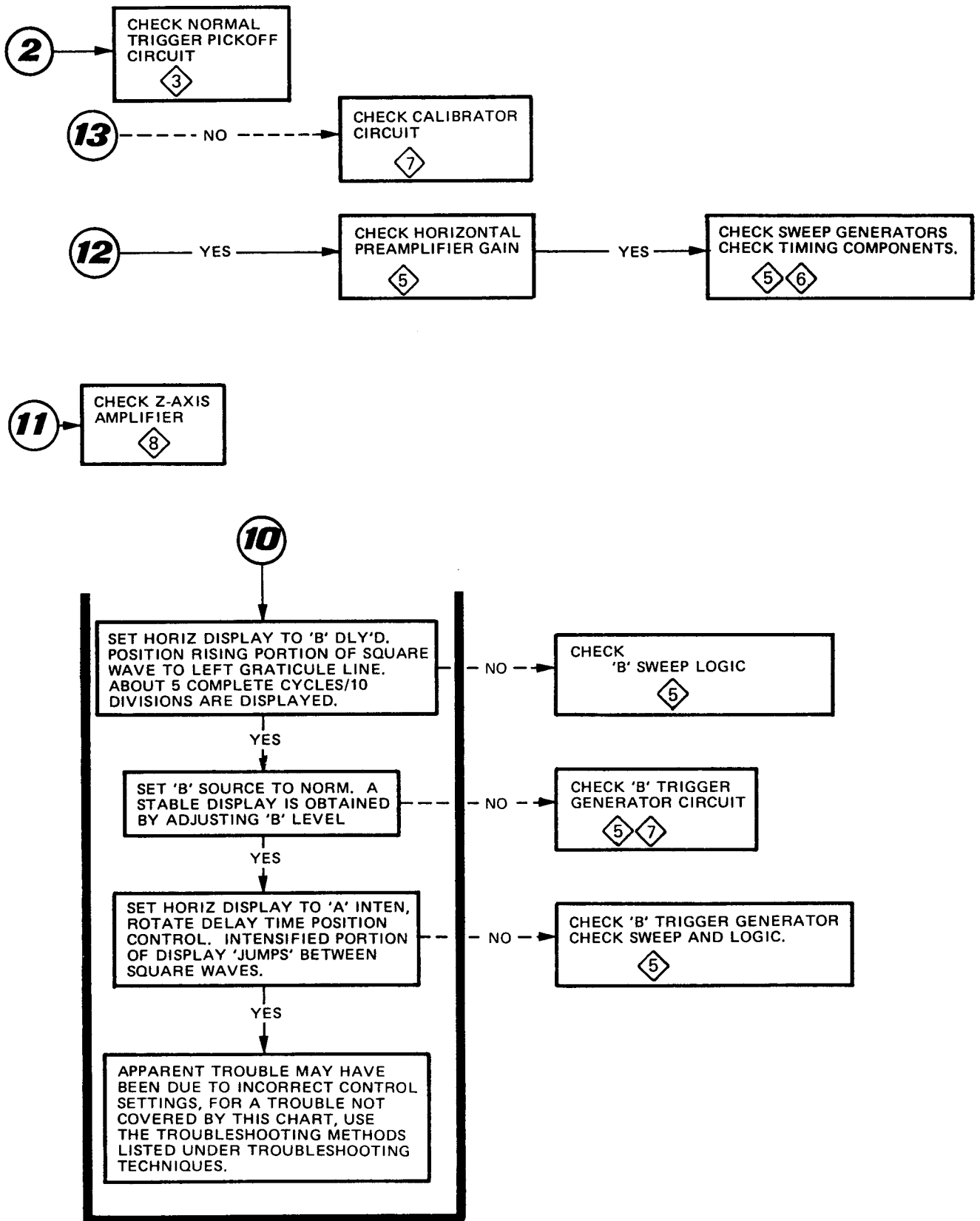

Figure 5-2. Troubleshooting chart (sheet 5 of 5).

NOTE

(5) **Semiconductor Lead Configurations.** Typical semiconductor lead configurations are shown in Figure 5-3.

b. Troubleshooting Techniques. The following procedures are arranged in an order that checks the simple trouble possibilities before proceeding with extensive troubleshooting. The first few checks ensure proper connection, operation, and calibration. If the trouble is not located by these checks, the remaining checks should aid in locating the defective component.

(1) **Check Control Settings.** Incorrect control settings can indicate a trouble that does not exist. If there is any question about the correct function or operation of any control, see the Operation Instructions section.

(2) **Check Associated Equipment.** Before proceeding with troubleshooting, check that the equipment used with this instrument is operating correctly. Check that the signal is properly connected and that the interconnecting cables are not defective. Also, check the power source.

(3) **Check Instrument Calibration.** Check the calibration of this instrument, or the affected circuit if the trouble exists in one circuit. The apparent trouble may only be misadjustment that can be corrected by calibration.

(4) **Visual Check.** Visually check the portion of the instrument in which the trouble is located. Many troubles can be located by visual indications such as unsoldered connections, broken wires, damaged circuit boards, and damaged components.

(5) **Isolate Trouble to a Circuit.** Using the troubleshooting chart Figure 5-2, isolate trouble to a particular circuit. The symptom often identifies the defective circuit. Trouble appearing in more than one circuit can indicate possible power supply problems. Power supply tolerance and ripple limits can be checked using Table 5-5. Power supply disconnect jumpers are provided for each of the supplies. Refer to the schematics and circuit board illustrations for their location. These jumpers can be unsoldered to disconnect the circuit load from most of the supplies. Each unregulated supply contains a fuse for circuit protection.

(6) **Check Circuit Board Interconnections.** After the trouble has been isolated to a particular circuit, check for loose or broken connections, improperly seated transistors and heat damaged components.

(7) **Check Voltages and Waveforms.** Often the defective component can be located by checking for the correct voltage or waveform in the circuit. Typical voltages are given on the diagrams. Waveforms are shown on the circuit diagram apron.

Voltages and waveforms given on the diagrams are not absolute and therefore may vary slightly between instruments. To obtain operating conditions similar to those used to take these readings, see the voltage and waveform set up procedures in the Diagrams section. Individual deviations should be noted on the schematics for future reference.

Table 5-5. Power Supply Tolerance and Ripple.

Supply	Tolerance	Maximum Ripple (peak to peak)
-5 V	± 1.1% (5.5 mV)	1 mV
+5 V	± 1.1% (5.5 mV)	1 mV
+32 V	± 0.6% (192 mV)	1 mV
+95 V	± 2.0 V	1 V
-2 kV	±1.25% (25 V)	200 mV

(8) **Check Individual Components.** The following procedures describe methods of checking individual components. Components which are soldered in place are best checked by disconnecting one end. This isolates the measurement from the effects of surrounding circuitry.

WARNING

The Power switch must be turned off before removing or replacing components to prevent electrical shock or circuit damage.

(a) **Semiconductors.** A good check of transistor operation is actual performance under operating conditions. A transistor can be most effectively checked by substituting a new component for it (or one which has been checked previously). However, be sure that circuit conditions are not such that a replacement transistor might also be damaged. If substitute transistors are not available, use a dynamic tester. Static type testers are not recommended, since they do not check operation under simulated operating conditions.

1 When troubleshooting transistors in the circuit with a voltmeter, measure the emitter to base and emitter to collector voltages to determine if the voltages are consistent with normal circuit voltages. Voltages across a transistor vary with the type of device and its circuit function. Some of these voltages are predictable. The emitter to base voltage of a conducting silicon transistor will normally be 0.6 to 0.8 volts. The emitter to collector

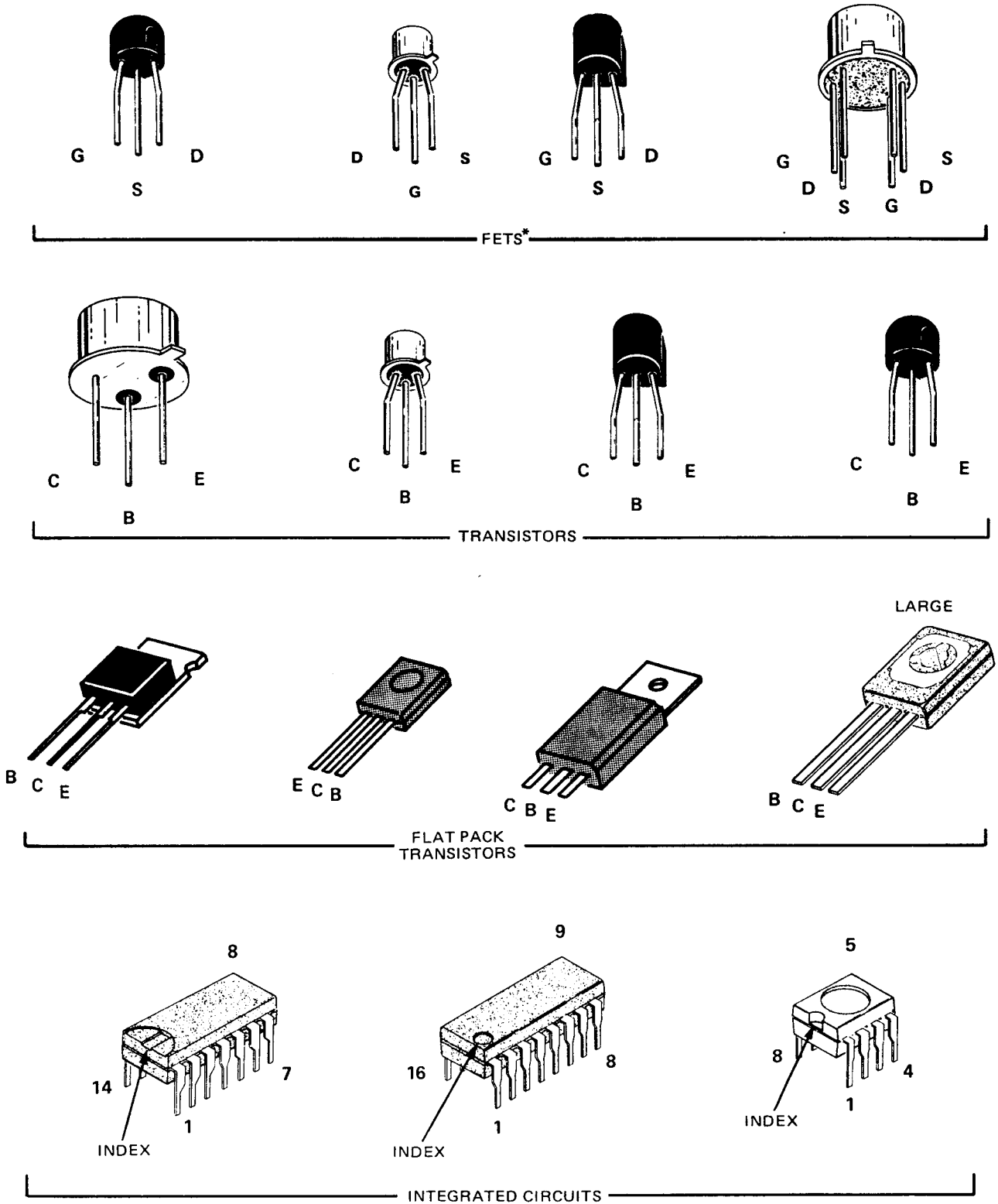

* SOURCE AND DRAIN DESIGNATION REVERSED FROM STANDARD TO MATCH SCHEMATIC DIAGRAM.

Figure 5-3. Semiconductor lead configurations.

voltages of a saturated transistor is about 0.2 volts. Because these values are small, the best way to check them is by connecting the voltmeter across the junction and using a sensitive voltmeter setting, rather than by comparing 2 voltages taken with respect to ground (both leads of the voltmeter must be isolated from ground if this method is used). If values less than these are obtained, either the device is short-circuited or no current is flowing in the circuit. If values are in excess of the base emitter values given, the junction is back biased or the device is defective. Values in excess of those given for emitter collector could indicate either a nonsaturated device operating normally, or a defective (open-circuited) transistor. If the device is conducting, voltage will be developed across resistances in series with it; if it is open, no voltage will be developed across resistances in series with it unless current is being supplied by a parallel path.

2 When troubleshooting field effect transistors, the voltages across its elements can be checked in the same manner as transistors. However, it should be remembered that normal depletion mode operation has the gate to source junction reverse biased, while the enhanced mode has the junction forward biased.

3 IC's (integrated circuits) can be checked with a voltmeter, test oscilloscope, or by direct substitution. A good understanding of circuit operation is essential to troubleshooting circuits using IC's. Use care when checking voltages and waveforms around the IC's so that adjacent leads are not shorted together. A convenient means of clipping a test probe to the 14-and 16-pin IC's is with an IC test clip. This device also doubles as an extraction tool.

(b) **Diodes.** A diode can be checked for an open or for a short circuit by measuring the resistance between terminals with an ohmmeter set to the R X 1 kilohm scale. The diode resistance should be very high in one direction and very low when the meter leads are reversed.

CAUTION

Do not use an ohmmeter scale that has a high internal current. High currents can damage diodes. Check diodes in the same manner as transistor emitter to base junctions. Silicon diodes should have 0.6 to 0.8 volts across the junction when conducting. Higher readings indicate that they are either back biased or defective, depending on polarity.

(c) **Resistors.** Check the resistors with an ohmmeter. Check the parts list for tolerance of the resistors used in this instrument. Resistors normally do not need to be replaced unless the measured value varies considerably from the specified value.

(d) **Inductors.** Check for open inductors by checking continuity with an ohmmeter. Shorted or partially shorted inductors can usually be found by checking the waveform response when high-frequency signals are passed through the circuit.

(e) **Capacitors.** A leaky or shorted capacitor can best be detected by checking resistance with an ohmmeter on the highest scale. Do not exceed the voltage rating of the capacitor. The resistance reading should be high after initial charge of the capacitor. An open capacitor can be detected with a capacitance meter or by checking whether the capacitor passes ac signals.

(f) **Attenuators.** The thick film attenuators are best checked by substitution. If only one channel is not operating properly, and there is reason to believe an attenuator is defective, replace the suspected attenuator with the same attenuator from the other channel and check instrument operation. If proper operation results, replace or repair the defective attenuator.

5-4. CALIBRATION AND CHECKOUT AFTER REPAIR. Whenever repairs involve the power supplies or instrument disassembly, Calibration and an Operational Checkout should be performed.

5-5. COMPONENT REMOVAL, REPLACEMENT, AND DISASSEMBLY.

WARNING

To prevent electrical shock or damage to the instrument, always disconnect the instrument from the power source before removing or replacing components. Also, review the Safety Summary page in the front of this manual.

a. Cabinet Top and EMI Shield Removal and Replacement.

(1) Using a coin or large bladed screwdriver, rotate the three circular locks on each side of the cabinet (see Figure 5-5) counterclockwise until the slots are vertical.

(2) Lift the cabinet top straight up.

(3) Remove the five screws holding the EMI Shield (2 on left side near the front, 2 on the top at the rear, and 1 on the top right at the front).

(4) Lift the EMI Shield straight up.

(5) Replace the EMI Shield and cabinet top in reverse order.

b. Interconnecting Cables and Connectors (Figure 5-4).

The interconnecting cable assemblies are factory assembled. They consist of machine installed pin connectors mounted in plastic holders. The plastic holders are easily replaced as individual items, but if the connectors are faulty, the entire cable should be replaced. It is possible for the pin connectors to become dislodged from the plastic holders. If this happens, the connector can be reinstalled as follows:

(1) Bend grooved portion of holder away from cable as shown.

(2) Reinsert connector into its hole in the plug-in portion of holder. Wires are positioned in holder according to color code system (see note below).

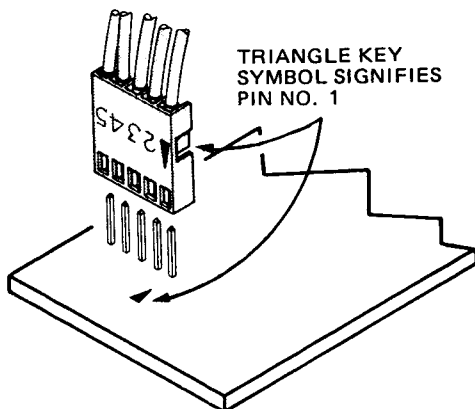
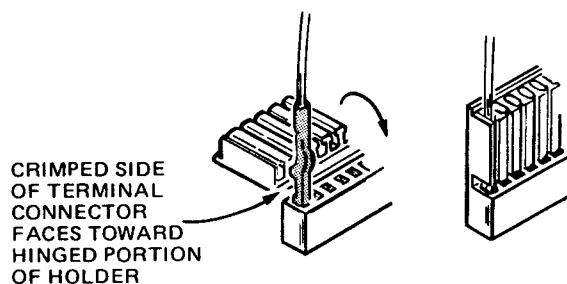

Figure 5-4. Multiconductor connector identification.

NOTE

Holder positions are numbered (number one is identified with a triangle). The wires are EIA color coded to match the numbers on the holder. For example, brown stripe for position 1 (triangle), red stripe for position 2, yellow stripe for position 4, etc.

(3) Bend grooved part of holder so that connector is inserted into groove.

(4) When plugging connector holders on to board pins, be sure to match triangle mark on holder with triangle mark on circuit board.

c. Rear Panel Assembly Removal and Replacement (Figure 5-5).

(1) Remove the cabinet top.

(2) Unplug the power cord.

(3) Unplug the coaxial connector end at the +A GATE OUT (white wire with yellow trace) and CH 2 OUT (white wire with brown trace) connectors located on the A8 Sweep and A5 Vertical boards, respectively.

(4) Remove the four screws on the inside corners of the rear subpanel.



When removing the rear panel in the next step, be careful not to break or damage the attached wiring or cables.

(5) While carefully pulling the top of the rear panel away from the mounting brackets lift the bottom up and out of the groove in the cabinet bottom. Then lay the rear panel on its back and disconnect the attached wires and cables.

(6) Replace the rear panel in the reverse order. Reconnect the wires and cables. Then hold the panel vertical and set it into the groove in the cabinet bottom. Align the screw holes and install the four corner screws. If the rear panel wires and cables were not tagged when removed, the following may be useful.

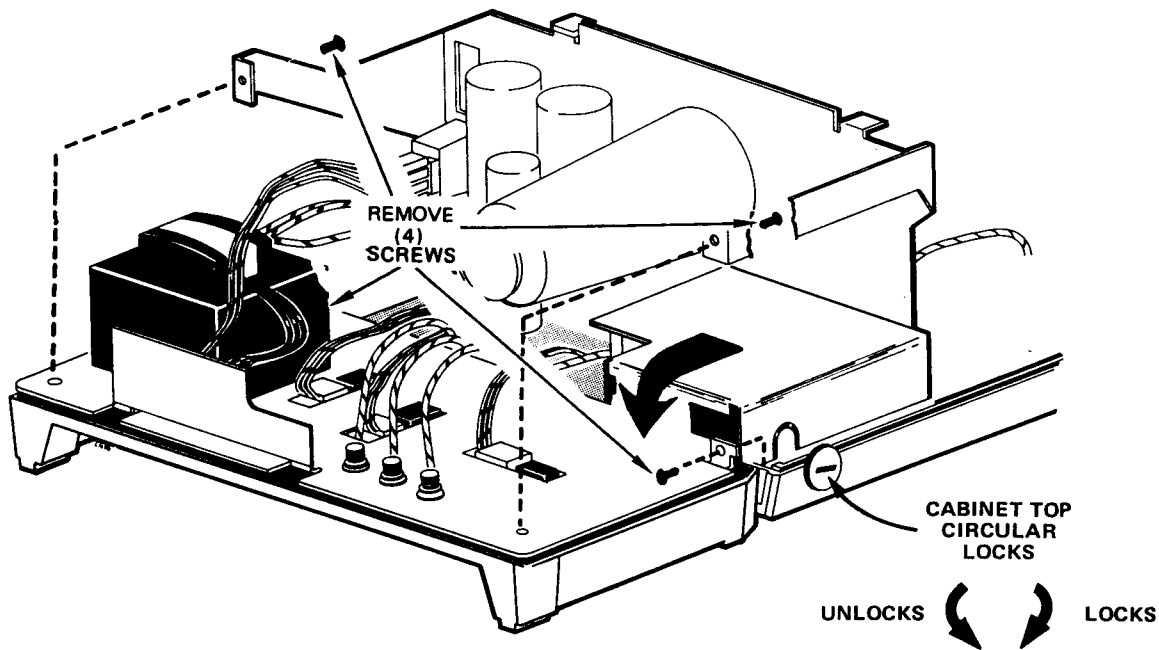

Figure 5-5. Rear panel removal.

(a) The input power wires and power transformer leads are color coded as shown on the schematic diagrams. Also, the circuit board lead mounting holes for the rectifiers are color code numbered for the transformer leads (e.g., 2 is red, 6 is blue, etc).

(b) The clear plastic connectors for the transistors on the rear panel can be installed only with the mounting holes closest to the panel. These transistors are numbered Q736, Q746, and Q768 starting at the power transformer and moving away from it. They connect to number matching plugs (e.g., Q736 to J736, etc.) on the A11 board. Be sure multiconductor holders are installed with proper triangle key orientation (see Figure 5-4).

d. Cabinet Bottom Removal and Replacement (Figure 5-6).

- (1) Remove the cabinet top.
- (2) Raise the front of the instrument and remove the four external screws from the cabinet bottom.
- (3) Remove the rear panel assembly.
- (4) Remove the remaining seven internal screws from the cabinet bottom.

(5) Lift the instrument off the cabinet bottom.

(6) Replace the bottom in the reverse order of removal. When installing the four external screws in front part of the cabinet bottom, the floating nuts inside the instrument along side the front part of the crt, may need to be aligned.

e. Vertical Module Removal (Figure 5-7).

- (1) Remove the remaining screw holding the module.
- (2) Unplug CH 2 OUT cable, vertical deflection plate leads, and multiconductor connector to the horizontal module.
- (3) Pull plug in module straight up and away from interface connector.
- (4) Reinstall the module in reverse order. Be sure CH 2 OUT cable is routed through cutout at bottom of module.

f. Horizontal Module Removal (Figure 5-8).

- (1) Remove the remaining screw holding the module.

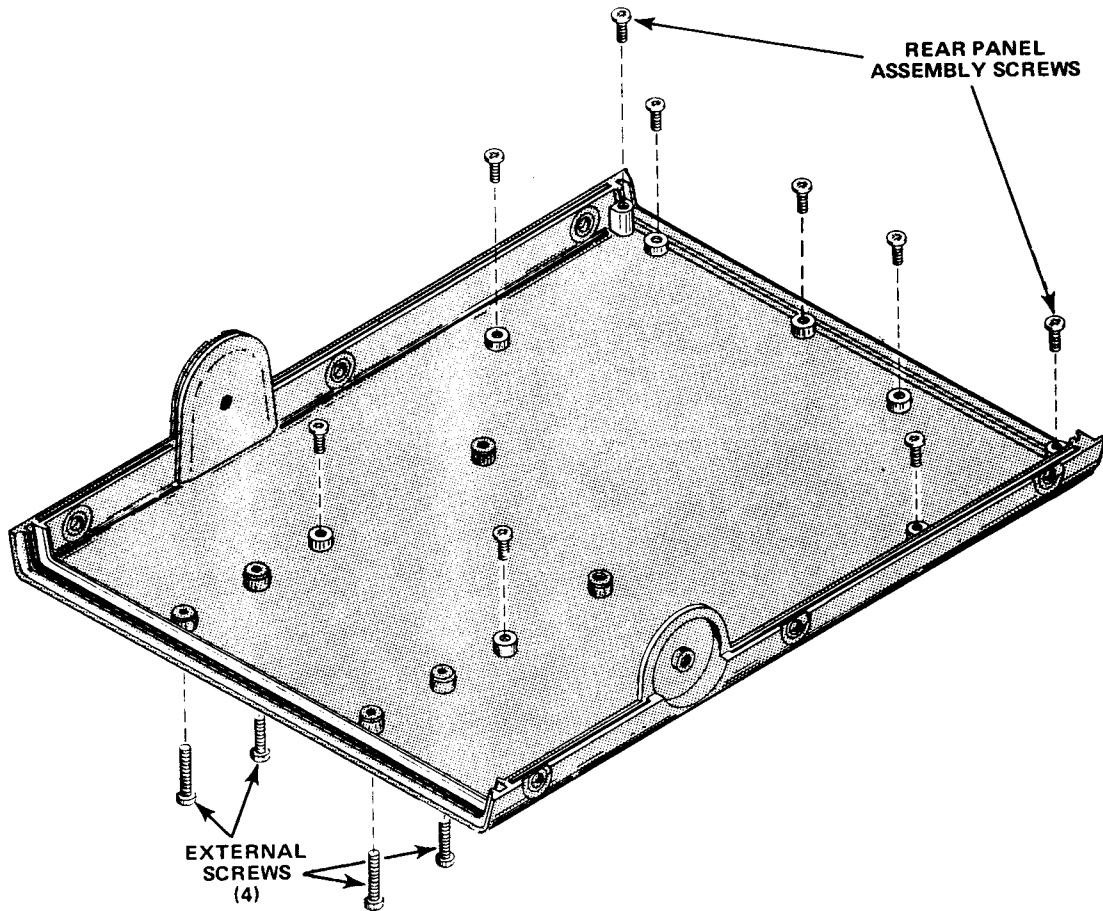

Figure 5-6. Cabinet bottom removal.

(2) Unplug multiconductor connector to vertical module and +A GATE OUT cable.

(3) Unsnap the POWER switch extension rod from yokes on POWER switch shaft.

(4) Pull plug in module straight up and away from interface connector.

(5) Reinstall the module in reverse order. Be sure plastic yokes on POWER switch are aligned before reinstalling the extension rod.

g. Cathode Ray Tube (Crt) Removal.

WARNING

Handle crt carefully. Rough handling or scratching may cause crt to implode.

(1) Remove vertical module.

(2) Remove plastic bezel and filter on front of crt.

(3) Unplug crt anode lead and discharge to chassis.

(4) Unplug crt base socket.

NOTE

When removing leads in the next two steps make a note of the lead color, or tag the leads.

(5) Disconnect two vertical deflection plate leads from left side of crt neck.

(6) Disconnect two horizontal deflection plate leads from the circuit board.

(7) Hold crt face in one hand and slowly push crt base with other hand.

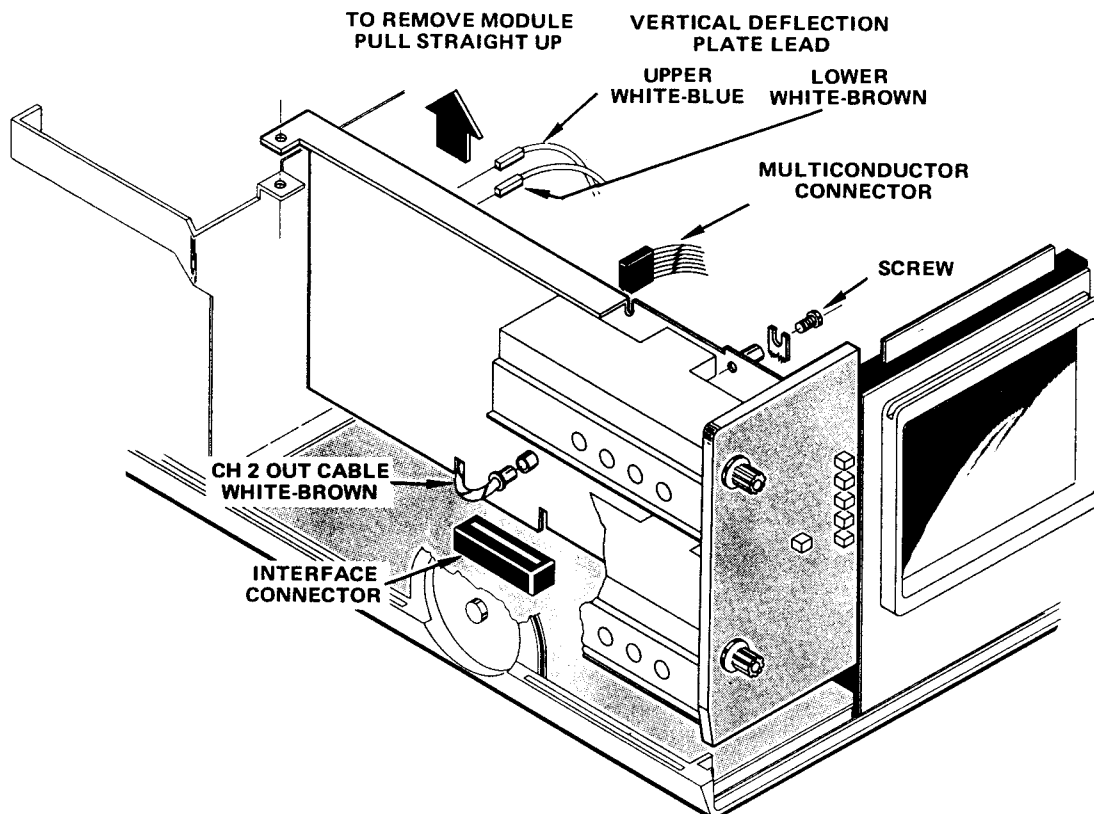

Figure 5-7. Vertical module removal.

(8) Carefully pull crt out of shield (watch horizontal deflection leads).

(9) Reinstall the crt in reverse order.

h. Shaft-Knob Removal (Figure 5-9).

(1) Grip knob end with one hand and shaft with other hand.

(2) Pull on knob, while pushing on shaft, to free recessed portion of shaft from retainer bushing. Some shaft-knobs may require considerable force to remove.

(3) Replace the shaft-knob in reverse order.

i. Interface Board Removal.

(1) Remove the vertical and horizontal modules.

(2) Lift up the front of the instrument and remove the four external cabinet bottom screws.

(3) Unplug the crt socket.

(4) Remove the high voltage shield.

(5) Remove the shaft-knob from INTEN, ASTIG, FOCUS, TRACE ROTATION, and SCALE ILLUM controls (see h. above).

(6) Unplug the crt anode lead and discharge it to the chassis.

(7) Unplug the crt vertical deflection plate leads from crt (left side) and horizontal deflection plate leads from the Interface circuit board.

(8) Unplug the crt trace rotation and Y-Axis leads coming from the top of the crt.

(9) Remove the ground post and bracket at the top rear of the crt shield.

(10) Carefully lift the crt assembly (crt, shield, and center front section) forward and up away from the chassis.

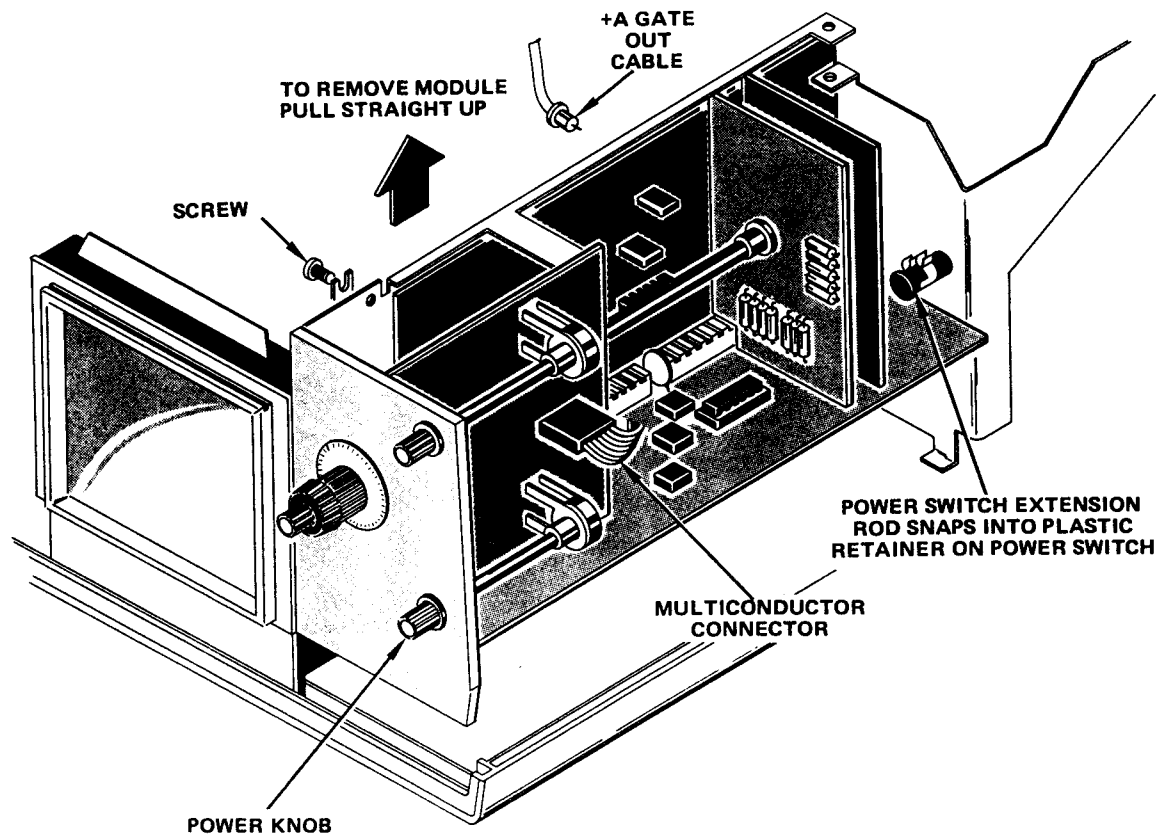

Figure 5-8. Horizontal module removal.

The BEAM FINDER push button should slip out of the assembly.

(11) Remove the two screws and two nuts holding the power supply chassis divider. Loosen the small screw in the front lower right corner of this chassis (there is a heat sink on the other side). Carefully remove the chassis.

(12) Remove the rear panel and disconnect the wires and cables to the Interface Board.

(13) Remove the remaining screws holding the Interface Board to the cabinet bottom.

(14) Reinstall the board in reverse order. Be sure to properly install the heat sink when replacing the divider chassis in step (11).

j. A and B Timing Switch Board Assembly Removal and Replacement (Figure 5-10).

(1) Remove the horizontal module.

(2) Remove the VAR (1 hex screw) and the TIME/DIV knobs by loosening their set screws with a 1/16 inch hex wrench.

(3) Remove the two screws and hex nuts holding the switch board assembly.

(4) Remove the TIME/DIV knob skirt by loosening its set screw with a 5/64 inch hex wrench.

CAUTION

When removing the assembly in the next step, be careful not to bend the connector pins on the A8 Sweep Board.

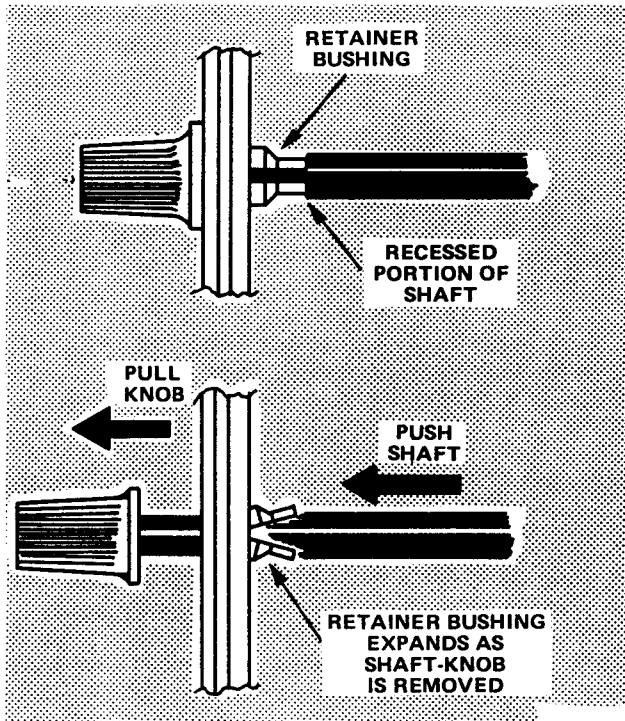

Figure 5-9. Shaft-knob removal.

(5) Carefully pull the board assembly away from the Sweep Board until it just unplugs. Then pull the board assembly toward the rear of the module until the switch shaft exits the front panel.

(6) Reinstall the assembly as follows:

(a) Guide the switch shaft through the front panel opening and carefully plug the board into the Sweep board.

(b) At the switch, rotate the shaft fully counterclockwise, then two positions clockwise (.2 ms). Install the plastic knob skirt and tighten its set screw.

(c) At the switch, rotate the A TIME/DIV shaft fully counterclockwise. At the knob end, rotate the B TIME/DIV shaft fully counterclockwise.

(d) Install the TIME/DIV knob such that the white line points to the same setting as the black bordered window on the knob skirt (pointing at X-Y). Tighten the set screws.

(e) At the VAR potentiometer, rotate the VAR shaft fully clockwise into the detent. Install the VAR knob with the name horizontal and tighten the set screw.

(f) Set TIME/DIV to X-Y. Pull the B TIME/DIV knob and rotate fully clockwise. In properly installed, B TIME/DIV should set to .05 μ s and cause A TIME/DIV to set to .2 s.

k. A AND B Timing Switch Disassembly (Figures 5-10 and 5-11).

(1) Remove the VAR shaft by loosening its set screw at the VAR potentiometer coupling with a 0.050 inch hex wrench.

(2) Remove the four screws holding the switch and boards together. Separate the boards, being careful that the switch doesn't fall out. Also, do not lose the two plastic nut retainers.

CAUTION

Do not touch the switch contact wipers as they are easily damaged or contaminated. Do not use a brush or swab to clean the wipers. Whenever the switch is separated from the boards, it should be placed in some type of container for protection from damage or contamination.

(3) Clean the switch contact pads with a soft eraser (pencil type).

(4) Clean the boards with isopropyl alcohol.

(5) Reassemble the switch as follows:

(a) Insert the switch shaft through the A Timing Switch Board from the control side of the board and position the switch on the board.

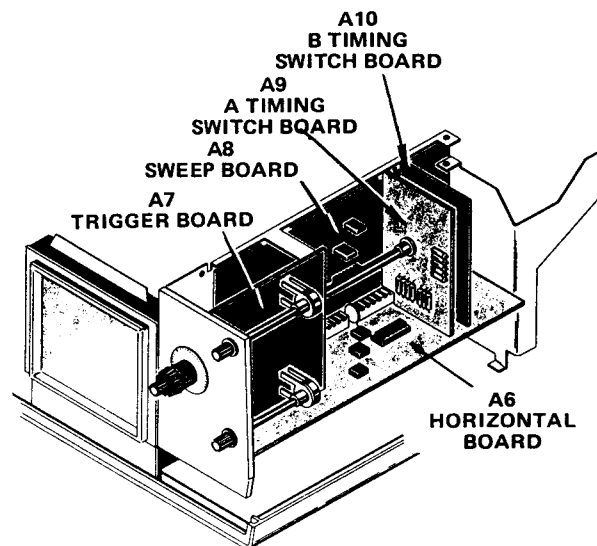

Figure 5-10. Horizontal module board locator.

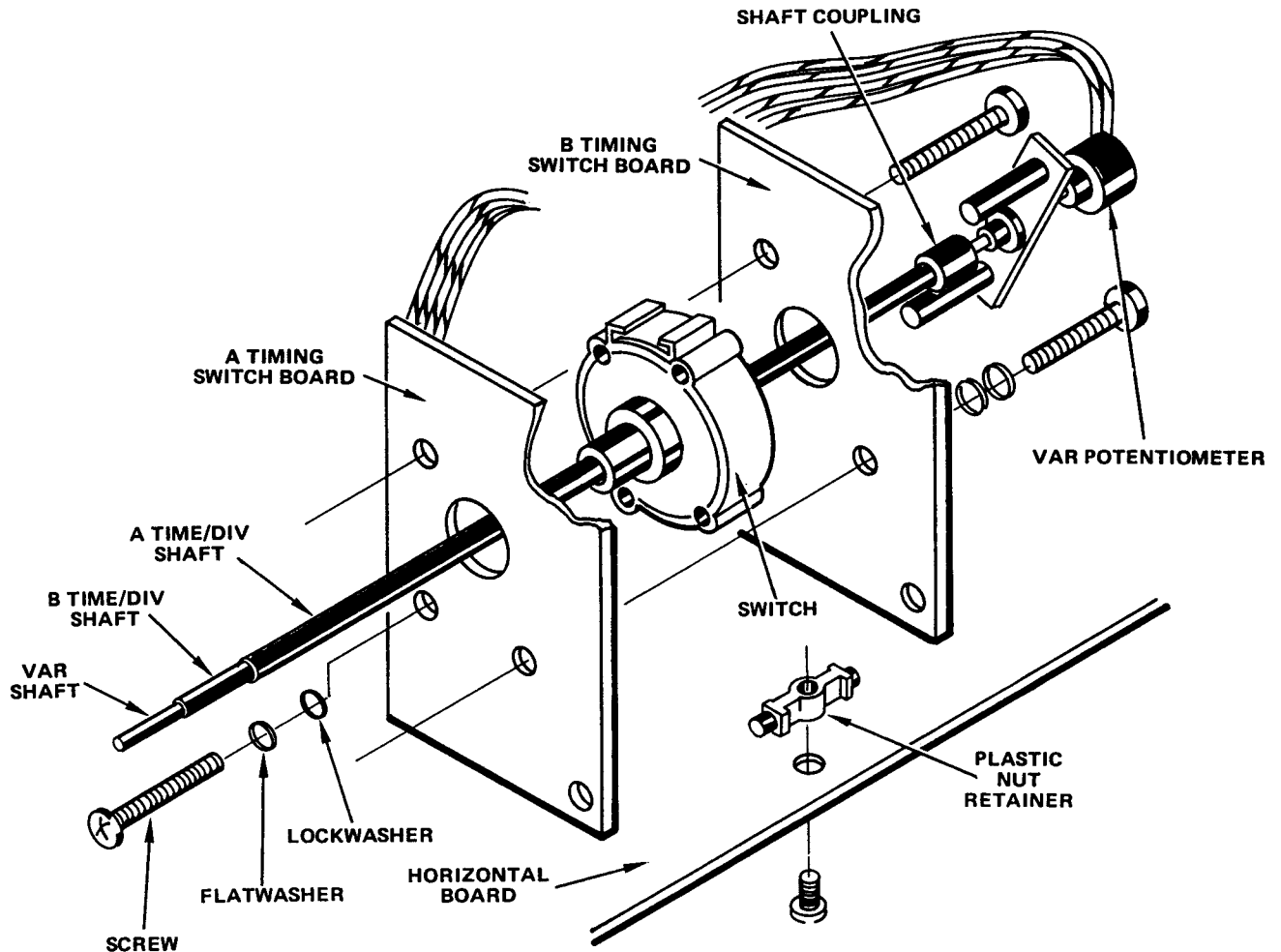

Figure 5-11. TIME/DIV switch disassembly.

NOTE

There are two small tabs on the switch—one round and one oval. These fit into properly sized holes for switch positioning.

(b) Set the remaining switch board on the switch. Be sure the two plastic nut retainers are in place. Install the two screws and nuts that hold the boards together (inserted from the B Timing Switch board side in the unplated holes), but do not tighten them.

(c) Install the VAR potentiometer using the remaining two screws, but do not tighten them.

(d) Install the VAR shaft (untapered end) in the VAR potentiometer and tighten the set screw with a 0.050 inch hex wrench.

(e) Tighten the four screws holding the assembly together.

I. Trigger Board Removal and Replacement (Figure 5-10).

- (1) Remove the horizontal module.
- (2) Unplug the three multiconductor connectors.
- (3) Unsolder the B Trigger external input and its ground at the rear of the BNC connector.
- (4) Remove one screw at top rear of board.
- (5) Carefully pull the bottom of the board toward the right until it just unplugs. Then pull the board out away from the module.

(6) Replace the board in reverse order.

m. Source and Coupling Switch Disassembly. These switches are disassembled by removing the one screw holding each set to the board. Once disassembled, the switch contact pads can be cleaned with an eraser (pencil type) and isopropyl alcohol. Reassemble the switches in reverse order.



Do not touch or clean the switch contact wipers as they are easily damaged or contaminated. Whenever the switches are disassembled, place the switches in a container to protect the wipers.

n. Horizontal Board Removal and Replacement (Figure 5-10).

(1) Remove the horizontal module.

(2) Remove the Trigger Board.

(3) Remove both screws holding the A and B Timing Switch Board Assembly. Unplug the assembly and move it far enough toward the top of the module to uncover the Horizontal Board plugs to the Sweep Board.

(4) Remove the horizontal POSITION and A TRIGGER HOLDOFF shaft knobs (see h. above).

(5) Remove the two screws holding the board (left rear corner and right front corner).

(6) Unsolder the A Trigger external input at the BNC connector and remove the board.

(7) Replace the board in reverse order.

o. Sweep Board Removal and Replacement (Figure 5-10).

(1) Remove the horizontal module.

(2) Remove the A and B Timing Switch Board Assembly.

(3) Remove the Trigger Board.

(4) Remove the Horizontal Board.

(5) Unplug the three multiconductor connectors going to front panel controls.

(6) Remove the four screws holding the board to the chassis and remove the board.

(7) Replace the board in reverse order.

p. Graticule Illumination Board Removal and Replacement.

(1) Remove the horizontal module.

(2) Remove the crt.

(3) Unplug the Graticule Illumination Board connector (beside the control potentiometer), and remove the board.

(4) Reinstall the board in reverse order.

q. Hybrid IC Removal and Replacement (Figure 5-12).



When removing the hybrid IC, handle it with care as the ceramic material may break or crack if dropped or hit sharply.

(1) Remove the vertical module.

(2) Release the TRIG VIEW/20 MHz BW switch shaft from the switch using a 0.050 inch hex wrench. Move it away from the hybrid IC.

(3) Release the INVERT switch shaft by holding the shaft and pulling off the gray push button. Rotate the shaft away from the hybrid IC.

(4) Insert a narrow blade screwdriver between the socket (near the lip) and the mounting clip. Carefully twist the screwdriver until the mounting clamp unlatches from the lip. While holding a finger on the mounting clamp to keep it from springing into the air, unlatch the other lip on the same side. Remove the mounting clamp.

(5) Lift out the hybrid IC.

(6) Replace the hybrid IC as follows:

(a) Note the index key on the hybrid IC and the socket, then set the IC into the socket.

(b) Hook one end of the mounting clamp over two of the lips on one end of the socket; hold this end of the clamp so it doesn't spring off the socket. Push the other end of the clamp down until it hooks over the other two lips.

(c) Return to step (3) above and continue the replacement in reverse order of removal.

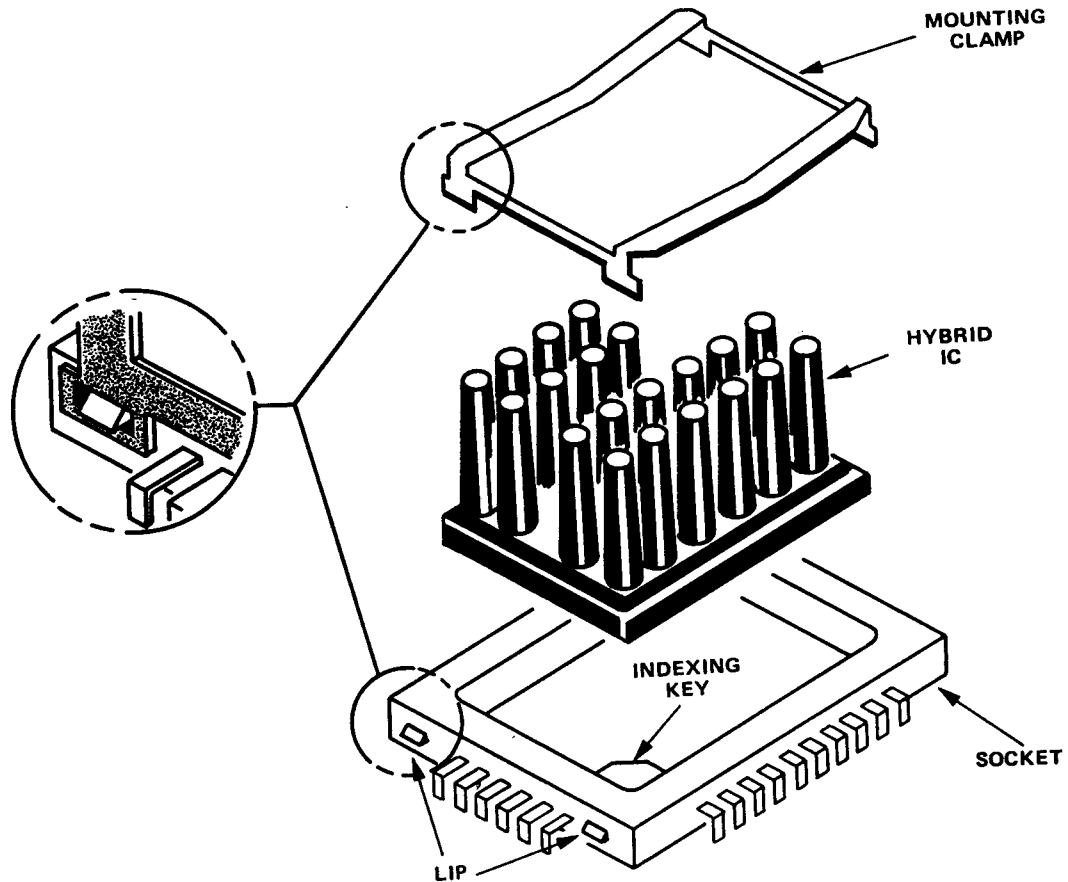

Figure 5-12. Hybrid IC removal.

r. VOLTS/DIV Attenuator Disassembly (Figure 5-13).

- (1) Remove the vertical module.
- (2) Remove the VAR knob and shaft by loosening the shaft coupling set screw at the VAR potentiometer with a 0.050 inch hex wrench.
- (3) Remove the VOLTS/DIV knob with skirt and shaft by pulling it away from the module.
- (4) Remove the vertical POSITION knob with shaft (see h. above).
- (5) Remove the attenuator shield by removing its four holding screws.
- (6) Remove the small grounding bracket at the front right part of the attenuator assembly by removing the nut just above the BNC connector and the screw under the front right corner of the assembly.
- (7) Unsolder the resistor and adjustable capacitor tab from the BNC center conductor.

(8) Remove the BNC connector by unscrewing the large nut and pulling the connector out through the front panel.

(9) Unplug the multiconductor connector from the Vertical Board (located near the rear of the attenuator).

(10) Remove the long, narrow shield on the soldered side of the Vertical Board.

(11) Unsolder the one pin connection under the shield removed in (10) above.

(12) Remove the remaining three screws holding the attenuator assembly to the chassis (one located on the soldered side of the Vertical Board near the top front corner; the other two are located on the chassis under the attenuator).

(13) Carefully remove the attenuator assembly. Watch the 4 pins unplug near the pin unsoldered in (11) above.

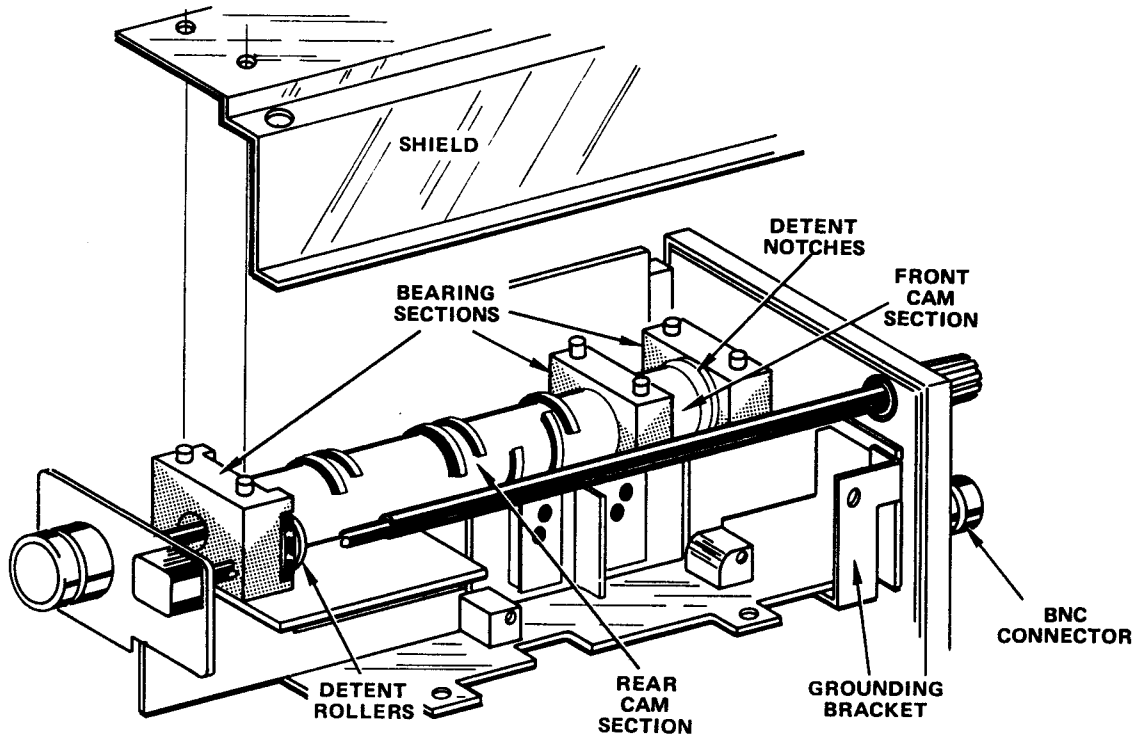

A. ATTENUATOR CAM AND BEARING SECTIONS

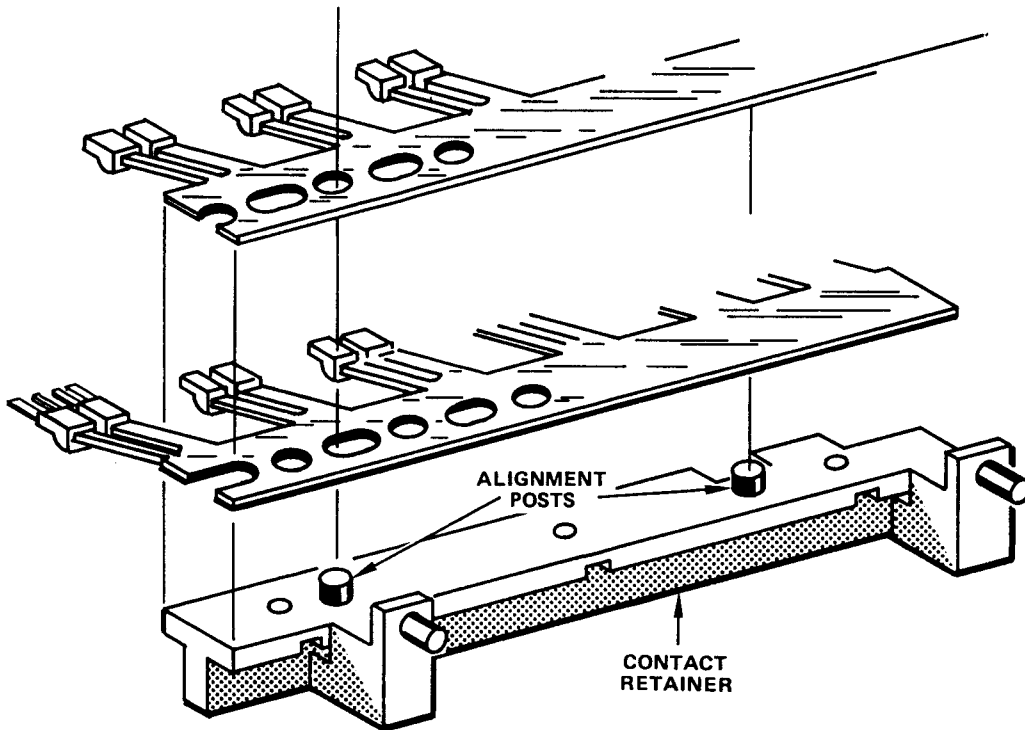

B. ATTENUATOR CONTACT ASSEMBLIES

Figure 5-13. VOLTS/DIV attenuator disassembly.

(14) Pull off the AC-GND-DC lever (may need to be very carefully pried away from the cam assembly with a small, thin blade screwdriver).

(15) Remove the three screws holding the cam bearing sections to the circuit board. Then lift the cam out of the assembly.

(16) Remove the three screws holding the contact retainer to the circuit board. Being careful that the two switch contact assemblies (wipers) do not fall out, or otherwise get damaged, lift the retainer out of the assembly. If the contact assemblies stay in the switch, lift them out. If they stick to the retainer, carefully pull them off.



If the contact assemblies are not to be immediately reinstalled, put them in a protective container to prevent damage or contamination.

(17) The switch contact pads on the circuit board can be cleaned with an eraser (pencil type) and isopropyl alcohol.

(18) The cam can be removed from the end bearing sections by pulling them out of the section with a twist.

(19) Reassemble the switch as follows:

(a) Install the contact assemblies on the contact retainer as shown in Figure 5-13B. Install these parts in the attenuator assembly. Be sure the plastic alignment posts on the contact retainer are properly inserted in the circuit board. Install the three contact retainer screws, but don't fully tighten them. Very carefully push the end contact assembly down to its pad and check the alignment. Move the contact retainer to align the contact assembly and pad, then tighten the three contact retainer screws.

(b) Install each of the two cams in an end bearing section. Set the notched detent end of the cam on the section, then push it into the bearing until it seats (the cam may need to be rotated to get the detent notches past the detent rollers).

NOTE

If new cam parts are being installed or the cam has been washed, very lightly lubricate the detent notches and cam ends with silicone grease.

WARNING

Handle silicone grease with care as it can cause skin or eye irritation. Wash hands thoroughly after use.

(c) Assemble the cam and three bearing sections so the attaching nuts are facing downward. Hold these parts together and set them into the attenuator assembly with the attaching nuts toward the circuit board. Install the three cam bearing section screws.

(d) Return to step (14) above and continue the reassembly in reverse order of disassembly.

s. Probe Disassembly and Repair.

(1) **BNC Connector.** The BNC connector on the P6101 probe is removed and replaced as shown in Figure 5-14.

(2) **Compensation Box.** To remove the compensation box and BNC connector section of the P6104 probe, grasp the retainer cover next to the compensation box with one hand. Then grasp the probe connector adjacent to the retainer cover with the other hand and pull the pieces apart. To reinstall the two parts, just push them together.

(3) **Probe Head.** The probe head on either the P6101 or P6104 probes can be removed by holding the probe head and the cable connector and pulling them apart.

(4) **Probe Cable.** By performing step (3) and either (1) or (2) above, the probe cable can be separated into one piece.

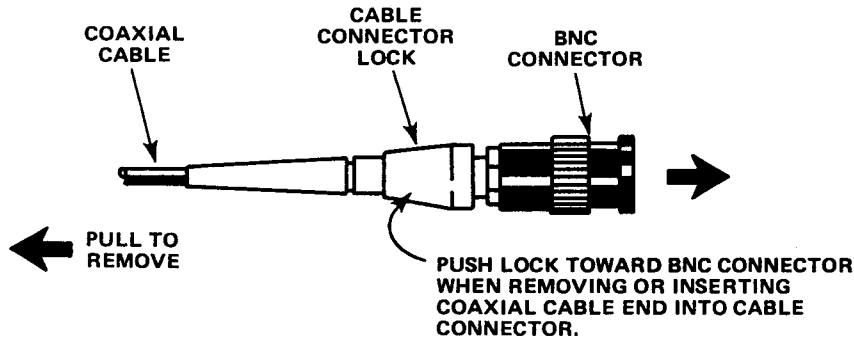

Figure 5-14. Probe BNC connector removal and replacement.

t. Light-Emitting Diode (LED) Replacement (Figure 5-15).

u. Push Button, Shaft Extension, and Shaft Extension Adapter Removal and Replacement.

NOTE

When unplugging the LED connectors, note which wire color is connected to the LED cathode. The LED shouldn't be damaged if reverse connected, but it won't light.

(1) To remove the small gray buttons on push button switches, hold the switch shaft and pull the button off. To replace them, hold the shaft and push the button on.

(1) Remove the LED from the front panel by pushing it out of the panel from the front.

(2) Unplug the LED connector.

(3) Reinstall the LED in reverse order.

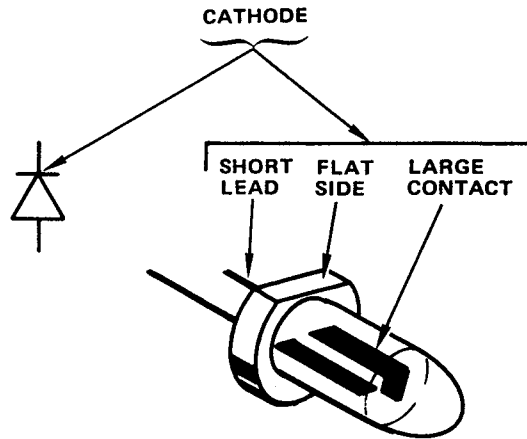

Figure 5-15. Light-emitting diode (LED) lead identification.

(2) To remove a shaft extension or its adapter, very carefully pry the connecting joint apart and pull the extension or adapters away from its connecting part.

5-6. CALIBRATION. The following instructions contain complete adjustment procedures for the instrument. When completed, the instrument should meet its original performance characteristics. The procedures are intended to be done in the sequence listed. Test equipment needed for the procedures is listed in Table 2-1. Whenever one procedural step interacts with another, an Interaction Note is provided.

VOLTS/DIV	.5 (1X window)
VAR	Fully clockwise (in detent)
AC-GND-DC	DC
POSITION (Vertical)	Midrange
VERT MODE	CH 1
20 MHz BW	In (off)
INVERT	Out (off)
SCALE ILLUM	Fully counterclockwise
HORIZ DISPLAY	A
TRIG MODE	AUTO
COUPLING	AC
SOURCE	NORM
SLOPE	OUT +
A AND B TIME/DIV	.5 μ s
VAR	Fully clockwise (in detent)
DELAY TIME POS	0.0
POSITION (Horizontal)	Midrange
A TRIGGER HOLDOFF	NORM (in detent)
X10 MAG	Out (off)

a. Preliminary Calibration Set-Up Procedure:

(1) Remove the top cabinet.

WARNING

To prevent electrical shock with the cabinet removed, do not touch exposed connections or components when the instrument is turned on, or connected to a power source.

(2) Turn on the instrument and allow at least five minutes warm-up.

NOTE

Instrument must be calibrated in an ambient temperature between +20° and +30° C (+68° to +86° F) to meet performance characteristics.

(3) Preset front panel controls as follows (set both vertical channels and horizontal sweeps the same unless otherwise indicated):

(4) Do not preset ASTIG and TRACE ROTATION. They will be adjusted later.

(5) Throughout the procedure INTEN, FOCUS, and LEVEL may be adjusted as necessary to obtain a visible, well defined, and stable display. Occasionally, these controls may be set by a procedural step.

b. +32 Volt Power Supply (Figure 5-16).

(1) Connect a digital voltmeter between +32 test point and GND.

(2) Adjust +32 V ADJ, R736 for a +32.0 voltage reading.

(3) Disconnect the voltmeter.

c. Crt Bias (Figures 5-17 and 5-18).

(1) Set A AND B TIME/DIV to X-Y.

(2) Connect a digital voltmeter between TP526 and GND.

(3) Set INTEN for about +20 volts (within 0.5 volt) voltage reading.

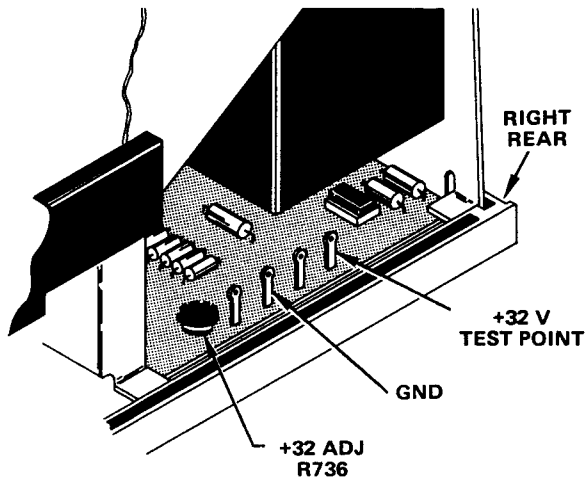

Figure 5-16. +32 volt test point and adjustment location.

(4) Disconnect the voltmeter.

(5) Adjust FOCUS and ASTIG for a well defined spot (if spot is not visible, adjust CRT BIAS, R532 until it is; then adjust FOCUS and ASTIG).

(6) Adjust CRT BIAS, R532 until the spot is just visible.

d. Z-Axis Compensation (Figure 5-17).

(1) Set A TIME/DIV to .5 μ s.

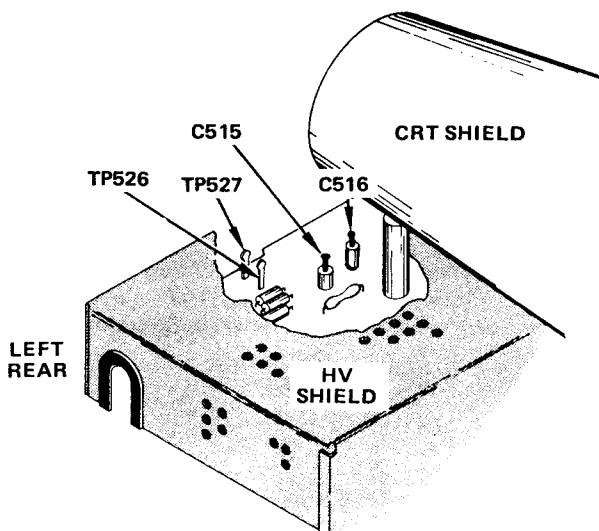

Figure 5-17. Crt and Z-Axis test point and adjustment locations.

(2) Set INTEN for a low intensity display.

(3) Connect a test oscilloscope between TP527 and GND with a 10X probe. Set test oscilloscope TIME/DIV for 2 μ s, adjust for a four division, positive going pulse display, and reset test oscilloscope TIME/DIV to 1 μ s.

NOTE

A high voltage oscillator signal will be visible, but should be ignored when making the adjustment in the next step.

(4) Adjust C515 and C516 for the squarest front corner on the displayed pulse.

(5) Disconnect the test oscilloscope.

e. Y-Axis Alignment (Figure 5-18).

(1) Set A AND B TIME/DIV to 1 ms and CH 1 AC-GND-DC to GND.

(2) Vertically position the display to the center horizontal graticule line.

(3) Adjust TRACE ROTATION to align the trace with the center horizontal graticule line.

(4) Set CH 1 AC-GND-DC to DC.

(5) Connect a time mark generator to CH 1 input through a 50 ohm BNC cable and 50 ohm termination. Set the generator for one millisecond time marks.

(6) Set CH 1 VOLTS/DIV for a display of greater than 8 divisions. Adjust vertical POSITION to place baseline of display below the bottom graticule line.

(7) Set A AND B TIME/DIV, its associated VAR control, and horizontal POSITION for exactly one time mark per division.

(8) Adjust Y AXIS, R573 to align the center time mark with the center vertical graticule line.

INTERACTION NOTE

This adjustment may affect the TRACE ROTATION adjustment. Position the display baseline to the center horizontal graticule line and recheck display alignment. If TRACE ROTATION needs readjustment, alternate between it and the Y-AXIS adjustments until no further adjustment is needed.

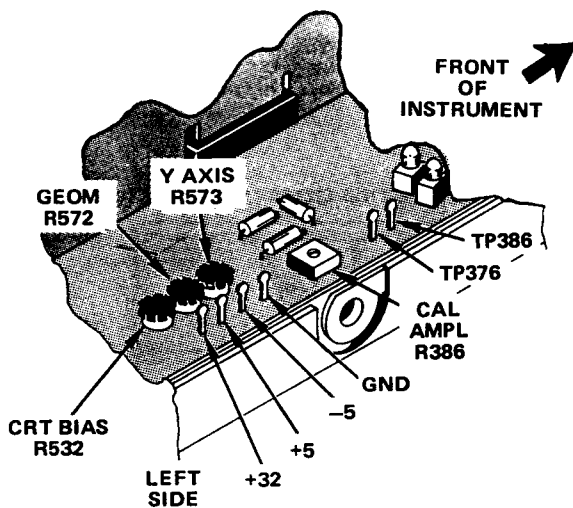

Figure 5-18. Crt and Calibration test point and adjustment locations.

(9) Continue to the next procedure.

f. Geometry (Figure 5-18).

(1) Readjust TIME/DIV VAR and horizontal POSITION for one time mark per division.

(2) Adjust GEOM, R572 for minimum bowing of time marks.

INTERACTION NOTE

This adjustment may affect Y-Axis Alignment and TRACE ROTATION. Repeat Y-Axis Alignment, TRACE ROTATION, and Geometry adjustments until the best alignment of all is reached.

(3) Reset TIME/DIV VAR fully clockwise in its detent.

(4) Disconnect the time mark generator.

g. Calibrator (Figure 5-18).

(1) Connect a digital voltmeter to the CALIBRATOR output.

(2) Connect a shorting jumper between TP376 and TP386 (a small alligator clip works nicely).

(3) Adjust CAL AMPL, R386 for a 1.00 volt reading.

(4) Remove the shorting jumper from TP376 and TP386.

(5) Disconnect the voltmeter.

h. Dc Balance (Figure 5-19).

(1) Set CH 1 and CH 2 VOLTS/DIV to 5 m (1X window) and A AND B TIME/DIV to .2 ms.

(2) Adjust CH 1 vertical POSITION to vertically center the trace.

(3) Adjust R4134 for no trace shift when switching CH 1 VOLTS/DIV between 5 m and 10 m.

(4) Set VERT MODE to CH 2.

(5) Adjust CH 2 vertical POSITION to vertically center the trace.

(6) Adjust R4234 for no trace shift when switching CH 2 VOLTS/DIV between 5 m and 10 m.

i. Vertical Gain (Figure 5-19).

(1) Set CH 1 and CH 2 VOLTS/DIV to 5 m (1X window) and VERT MODE to CH 1.

(2) Connect a calibration generator (select STD OUTPUT) to CH 1 input through an unterminated 50 ohm BNC cable. Set the generator for a 20 millivolt output.

(3) Adjust R4443 for a 4 division display.

(4) Set VERT MODE to CH 2.

(5) Move the calibration generator output from CH 1 input to CH 2 input.

(6) Adjust R4272 for a 4 division display.

(7) Continue to the next procedure.

j. Channel 2 Low Frequency Compensation (Figure 5-19).

(1) Set square wave generator (same as calibration generator, if using PG 506) for a 1 kilohertz, HIGH AMPL OUTPUT.

(2) Disconnect the square wave generator output from CH 2 and reconnect it to CH 2 through a 10X attenuator, 50 ohm termination, and an input RC normalizer. Set the generator for a 5 division display. During adjustments, maintain a 5 division display.

NOTE

Use a low capacitance tuning tool when making compensation adjustments.

(3) Adjust C4201 for the best flat top waveform.

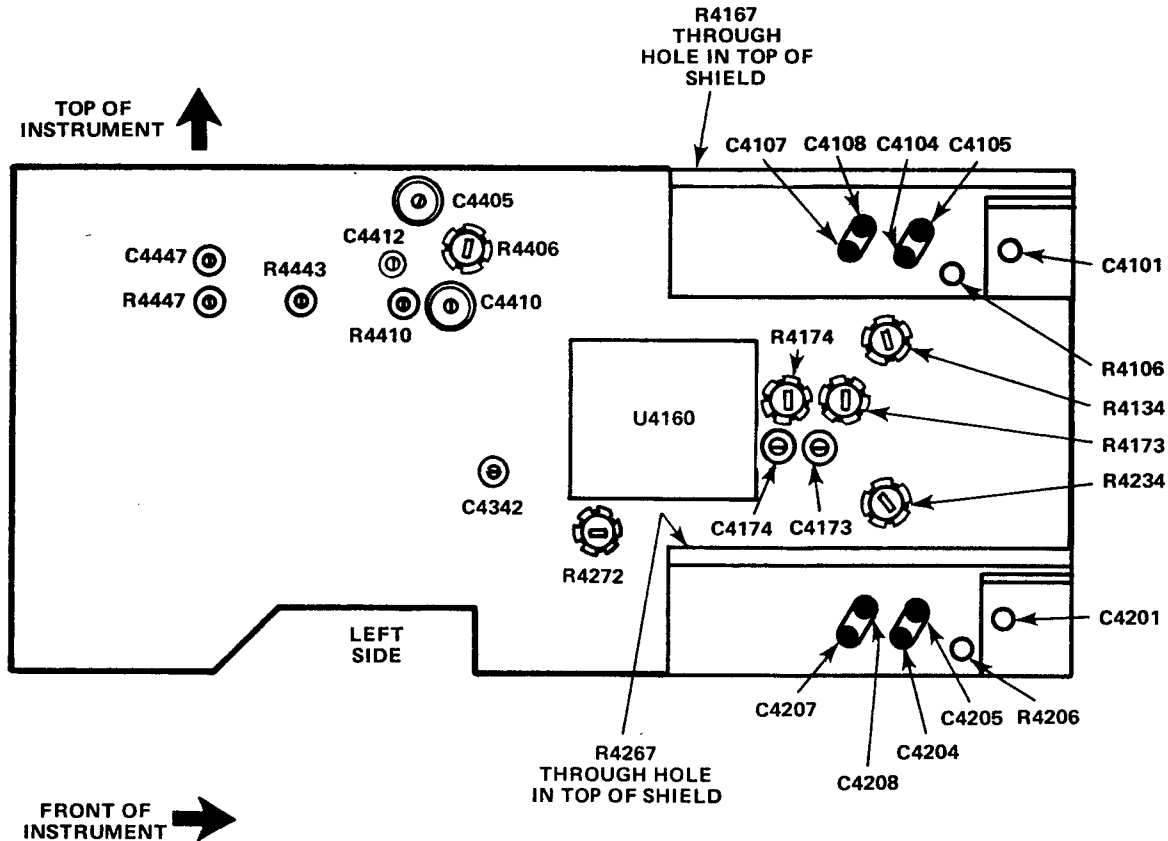

Figure 5-19. Vertical adjustment locations.

(4) Set CH 2 VOLTS/DIV to 50 m and reset generator for a 5 division display.

(5) Adjust C4208 for the best flat top, and C4207 for the best front corner on the waveform. Alternately readjust both capacitors for the best overall waveform response.

(6) Set CH 2 VOLTS/DIV to .5, remove the 10X attenuator, and reset the generator for a 5 division display.

(7) Adjust C4205 for the best flat top, and C4204 for the best front corner on the waveform. Alternately readjust both capacitors for the best overall waveform response.

(8) Continue to the next procedure.

k. Channel 1 Low Frequency Compensation (Figure 5-19).

(1) Set VERT MODE to CH 1.

(2) Remove the square wave generator output from CH 2 input and reconnect it to CH 1 through a 50 ohm BNC cable, 10X attenuator, 50 ohm termination, and an input RC normalizer.

(3) Set the generator output for a 5 division display. During adjustments, maintain a 5 division display.

NOTE

Use a low capacitance tuning tool when making compensation adjustments.

(4) Adjust C4101 for the best flat top waveform.

(5) Set CH 1 VOLTS/DIV to 50 m and readjust the generator for a 5 division display.

(6) Adjust C4108 for the best flat top, and C4107 for the best front corner on the waveform. Alternately re-adjust both capacitors for the best overall waveform response.

(7) Set CH 1 VOLTS/DIV to .5, remove the 10X attenuator, and readjust the generator for a 5 division display.

(8) Adjust C4105 for the best flat top, and C4104 for the best front corner on the waveform. Alternately re-adjust both capacitors for the best overall waveform response.

(9) Continue to the next procedure.

I. High-Frequency Compensation (Figure 5-19).

(1) Move the output of the square wave generator to its positive going, FAST RISE OUTPUT.

(2) Set CH 2 VOLTS/DIV to 5 m and VERT MODE to CH 2.

(3) Disconnect the square wave generator output from the CH 1 input, remove the input RC normalizer, install the 10X attenuator between the BNC cable and terminator, and connect the generator output to CH 2. Set the generator output to 1 kilohertz and adjust for a 5 division display. During adjustments, maintain a 5 division display.

(4) Adjust R4406 for the best flat top on the waveform.

(5) Set TIME/DIV to 20 μ s.

(6) Set generator to 10 kilohertz and adjust for a 5 division display.

(7) Adjust C4405 for the best flat top on the waveform.

(8) Set TIME/DIV to .1 μ s.

(9) Set generator for 100 kilohertz and adjust for a 5 division display.

(10) Push in X10 MAG (on).

(11) Adjust CH 2 vertical POSITION so top of waveform is on the center horizontal graticule line.

(12) Adjust R4410, C4410, C4342, C4412, C4447, and R4447 for the best front corner of the waveform. Total aberrations should not exceed $\pm 3\%$ or 3% peak to peak (+0.15 division, -0.15 division, or 0.15 division peak to peak).

(13) Set CH 2 VOLTS/DIV to 20 m.

(14) Adjust generator for a 5 division display.

(15) Adjust R4267 for the best front corner of the waveform.

(16) Set CH 2 VOLTS/DIV to .5.

(17) Remove the 10X attenuator from the generator input to CH 2.

(18) Adjust R4206 for the best front corner of the waveform.

(19) Reinstall the 10X attenuator in the CH 2 input. Set VOLTS/DIV to 5 m and TIME/DIV to .05 μ s. Adjust for a 5 division display. Check rise time. If it is greater than 3.5 nanoseconds repeat steps (2) through (18).

(20) Move the generator output from CH 2 input to CH 1 input.

(21) Set CH 1 VOLTS/DIV to 5 m and VERT MODE to CH 1.

(22) Adjust CH 1 vertical POSITION so top of waveform is on the center horizontal graticule line.

(23) Adjust C4173, R4173, C4174, and R4174 for the best transient response of the waveform. Total aberrations should not exceed $\pm 3\%$ or 3% peak to peak (+0.15 division, -0.15 division, or 0.15 division peak to peak).

INTERACTION NOTE

If CH 1 response cannot be adjusted within requirements, very slightly touch up the adjustment in step (12) above. Then recheck the CH 2 response and rise time of both channels.

(24) Set CH 1 VOLTS/DIV to 20 m and TIME/DIV to .1 μ s.

(25) Adjust R4167 for the best front corner of the waveform.

(26) Set CH 1 VOLTS/DIV to .5.

(27) Remove the 10X attenuator from the CH 1 input.

(28) Adjust R4106 for the best front corner of the waveform.

(29) Disconnect the generator.

NOTE

m. Trigger Hysteresis and Slope Centering (Figure 5-20).

(1) Set controls as follows:

VOLTS/DIV	5 m
A AND B TIME/DIV	5 μ s
X10 MAG	Out (off)
VERT MODE	CH 2
A LEVEL	0
A SOURCE	CH 2

(2) Connect a sine wave generator to CH 1 and CH 2 through a 50 ohm BNC cable, 50 ohm terminator, and dual input coupler. Set the output for 50 kilohertz and adjust for a 4 division display.

(3) Set R2245 at midrange.

(4) Adjust R2249 so trace starts at the same point when switching A SLOPE between IN: - and OUT: +.

(5) Set CH 2 VOLTS/DIV to .1, A AND B TIME/DIV to 50 μ s, and A SLOPE to OUT: +.

When making the next adjustment, set CH 2 VOLTS/DIV to .1 for a 0.2 division signal and .2 for a 0.1 division signal.

(6) Adjust R2245 and A LEVEL so a stable display is obtained with a 0.2 division display, but not with a 0.1 division display.

NOTE

If R2245 is set too sensitive, double triggering may occur at low frequencies. To desensitize R2245, adjust A LEVEL until the display just double triggers. Then slightly readjust R2245 until the double triggering disappears.

(7) Set CH 2 VOLTS/DIV to 5 m and A AND B TIME/DIV to 5 μ s.

(8) Repeat step (4) above.

(9) Set CH 2 VOLTS/DIV to 20 m and adjust A LEVEL for a stable display.

(10) Set controls as follows:

VERT MODE	CH 1
HORIZ MODE	B DLY'D
B SOURCE	CH 1
B LEVEL	0
A AND B TIME/DIV	5 μ s

(11) Set R2185 to midrange.

(12) Adjust R2183 so trace starts at the same point when switching B SLOPE between IN: - and OUT: +.

(13) Set CH 1 VOLTS/DIV to .1, A AND B TIME/DIV to 50 μ s, and B SLOPE to OUT: +.

NOTE

When making the next adjustment, set CH 1 VOLTS/DIV to .1 for a 0.2 division display and .2 for a 0.1 division display.

(14) Adjust R2185 and B LEVEL so a stable display is obtained with a 0.2 division display, but not with a 0.1 division display.

NOTE

If R2185 is set too sensitive, double triggering may occur at low frequencies. To desensitize R2185, adjust B LEVEL until the display just double triggers, then slightly readjust R2185 until the double triggering disappears.

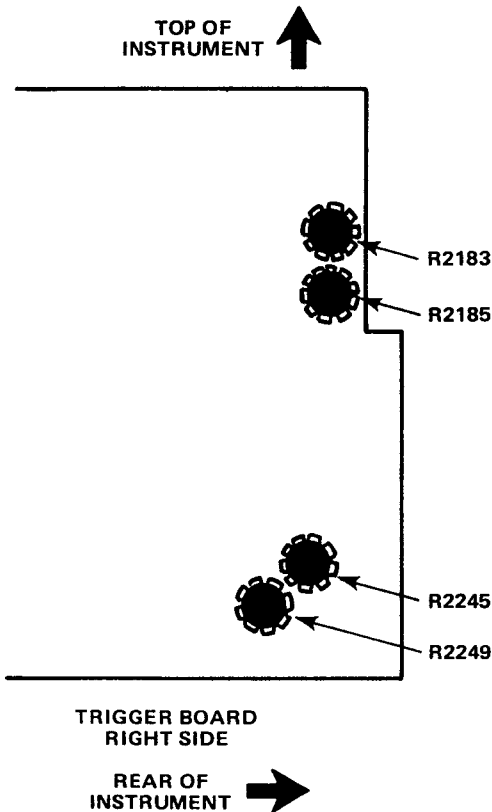

Figure 5-20. Trigger hysteresis and slope centering adjustment locations.

(15) Set CH 1 VOLTS/DIV to 5 m and A AND B TIME/DIV to 5 μ s.

(16) Repeat step (12) above.

(17) Disconnect the generator.

n. External Trigger Centering (Figures 5-21 and 5-22).

(1) Set controls as follows:

CH 2 VOLTS/DIV	5 m
VERT MODE	CH 2
HORIZ DISPLAY	A
A AND B TIME/DIV	5 μ s
A SOURCE	EXT
B SOURCE	EXT

(3) Set A COUPLING to AC.

(4) Adjust A LEVEL for a stable display.

(5) Set A COUPLING to DC.

(6) Adjust TRIGGER LEVEL CENTERING A, R2715 for a stable display.

INTERACTION NOTE

A LEVEL and R2715 may interact with each other; therefore, repeat steps (3) through (6) until no further adjustment of R2715 is needed.

(7) Set HORIZ DISPLAY to B DLY'D.

(8) Set B COUPLING to AC.

(9) Adjust B LEVEL for a stable display.

(10) Set B COUPLING to DC.

(11) Adjust TRIGGER LEVEL CENTERING B, R2615 for a stable display.

INTERACTION NOTE

B LEVEL and R2615 may interact with each other; therefore, repeat steps (3) through (6) until no further adjustment of R2615 is needed.

(12) Disconnect the sine wave generator.

o. Sweep Start-Stop (Figure 5-23).

(1) Set controls as follows:

VERT MODE	CH 1
CH 1 VOLTS/DIV	.5
A TIME/DIV	1 ms
B TIME/DIV	5 μ s
HORIZ DISPLAY	A INTEN
A SOURCE	NORM
B SOURCE	STARTS AFTER DELAY
COUPLING	AC

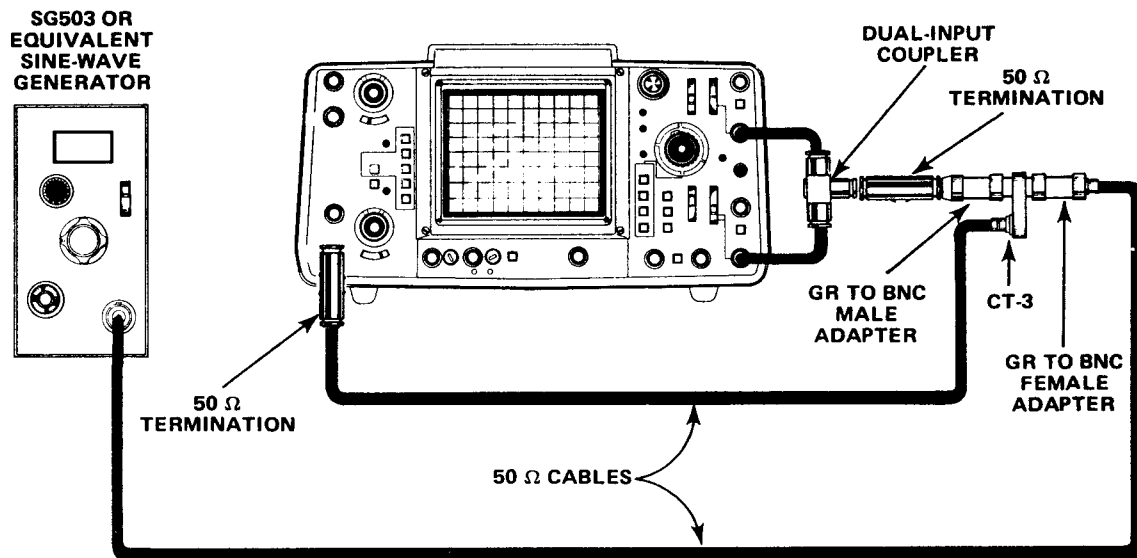

Figure 5-21. External trigger centering setup.

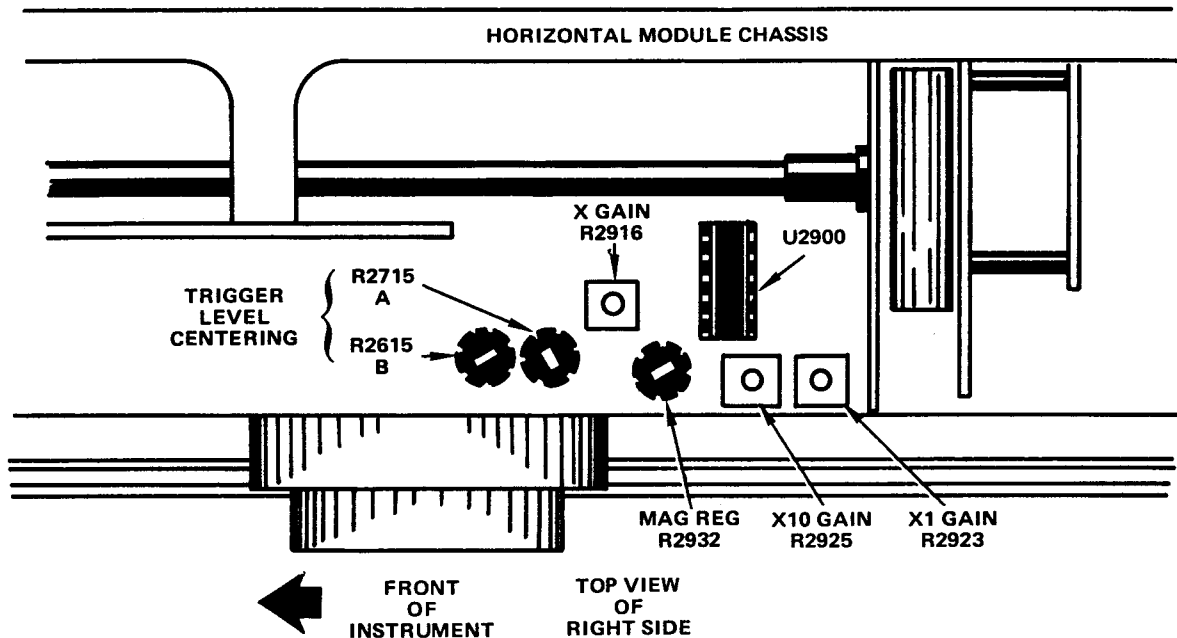

Figure 5-22. Trigger and horizontal adjustment locations.

(2) Connect a time mark generator to the CH 1 input through a 50 ohm BNC cable and 50 ohm terminator. Set the generator for 1 millisecond time marks.

(3) Set DELAY TIME POS to 1.00.

(4) Adjust R2782 so the second time mark is intensified.

(5) Set DELAY TIME POS to 9.00.

(6) Adjust R2748 so the tenth time mark is intensified.

INTERACTION NOTE

R2782 and R2748 may interact with each other; therefore, repeat steps (3) through (6) until no further adjustment is needed.

(7) Set HORIZ DISPLAY to B DLY'D and horizontally position the start of sweep within the graticule area.

(8) Set DELAY TIME POS to 1.00.

(9) Very slightly adjust R2782 until the time mark starts at the beginning of the sweep.

(10) Set DELAY TIME POS to 9.00.

(11) Very slightly adjust R2748 until the time mark starts at the beginning of the sweep.

INTERACTION NOTE

R2782 and R2748 may interact with each other; therefore, repeat steps (8) through (11) until no further adjustment is needed.

(12) Set DELAY TIME POS to 0.0.

(13) Continue to the next procedure.

p. Horizontal Gain (Figure 5-22).

(1) Set HORIZ DISPLAY to A.

(2) Adjust X1 GAIN, R2923 until the 1st and 11th time marks are exactly aligned with a graticule line. There should be one time mark per division within 0.25 minor divisions.

(3) Set X10 MAG to In (on).

(4) Set time mark generator for .1 ms time marks.

(5) Adjust X10 GAIN, R2925 for one time mark per division.

(6) Continue to the next procedure.

q. Magnifier Registration (Figure 5-22).

- (1) Set X10 MAG to In (on).
- (2) Adjust horizontal POSITION until the sweep starts at the center vertical graticule line.
- (3) Set X10 MAG to Out (off).
- (4) Adjust MAG REG, R2932 until the sweep starts at the center vertical graticule line.

INTERACTION NOTE

R2932 and horizontal POSITION may interact; therefore, repeat steps (1) through (4) until no further adjustment of R2932 is needed.

(5) Continue to the next procedure.

r. B Sweep Timing (Figure 5-23).

- (1) Set controls as follows:

X10 MAG	Out (off)
A AND B TIME/DIV	1 ms
HORIZ DISPLAY	B DLY'D
- (2) Set time mark generator for one millisecond time marks.
- (3) Set horizontal POSITION to align the first time mark with the left vertical graticule line.
- (4) Adjust R2682 for one time mark per division.
- (5) Continue to the next procedure.

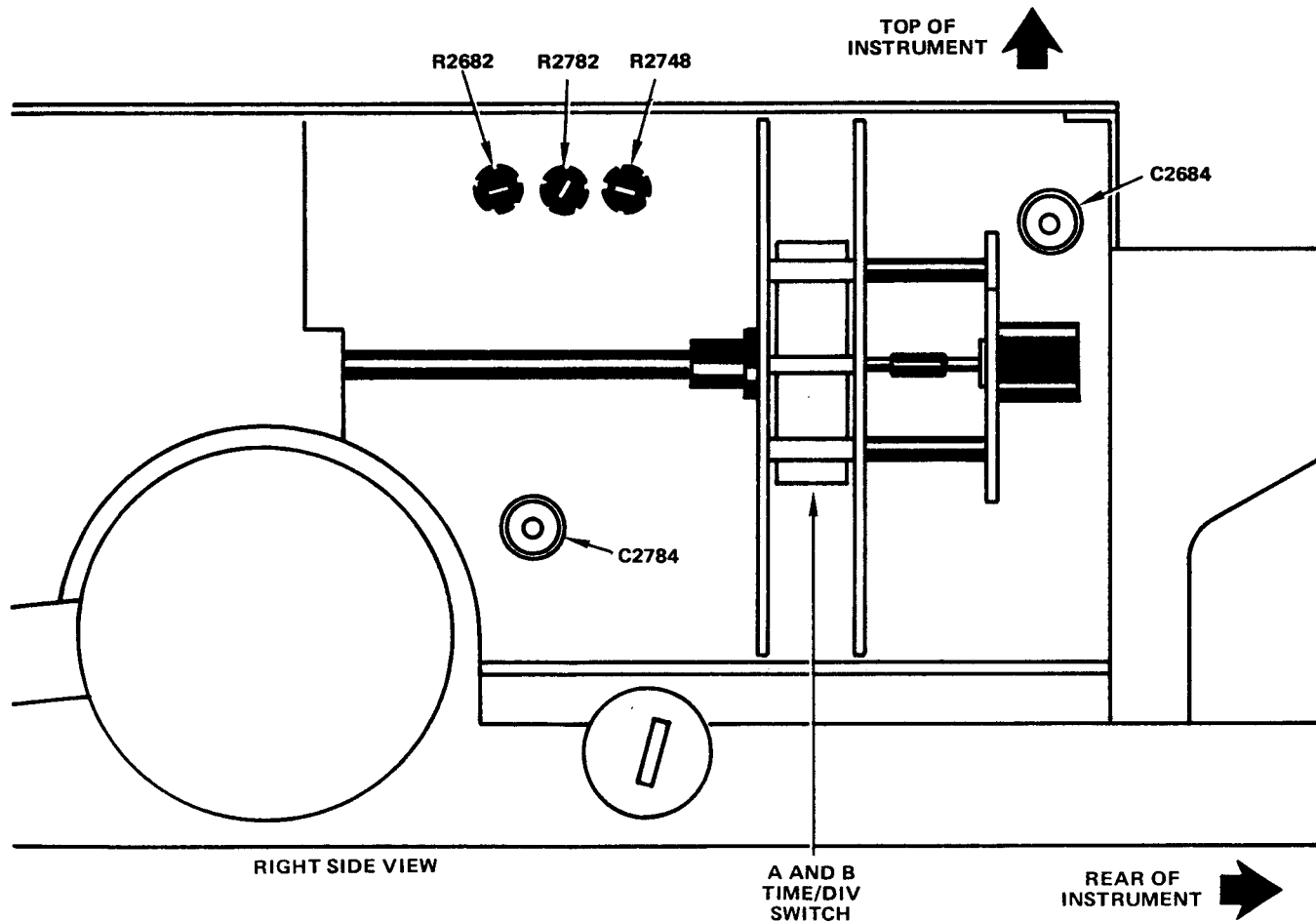

Figure 5-23. Sweep adjustment locations.

s. .5 μ s Timing (Figure 5-23).

(1) Set A TIME/DIV to .5 μ s and HORIZ DISPLAY to A.

(2) Set time mark generator for 0.5 microsecond time marks.

(3) Adjust C2784 for one time mark per division.

(4) Set HORIZ DISPLAY to B DLY'D.

(5) Set DELAY TIME POS to 1.00, then rotate it toward 0.0 until there is one time mark per division and a time mark is aligned with the left vertical graticule line.

(6) Adjust R2684 for one time mark per division.

(7) Set B TIME/DIV to .05 μ s and DELAY TIME POS to 1.00

(8) Adjust horizontal POSITION and align the time mark with the center vertical graticule line.

(9) Set DELAY TIME POS to 9.00.

(10) Very slightly adjust R2784 so the time mark aligns with the center vertical graticule line.

INTERACTION NOTE

R2784 and R2684 may interact; therefore, repeat this procedure until no further adjustment is needed.

(11) Set DELAY TIME POS to 0.0.

(12) Continue to the next procedure.

t. 5 ns Timing (Figure 5-24).

(1) Set controls as follows:

HORIZ DISPLAY	A
A AND B TIME/DIV	.05 μ s
X10 MAG	In (on)

(2) Set time mark generator for 10 nanosecond time marks.

(3) Adjust C232 and C272 for one time mark per two divisions.

INTERACTION NOTE

The adjustment screws for C232 and C272 should be adjusted to about the same height; otherwise, horizontal linearity may be degraded.

(4) Check the beginning and end of the .05 microsecond sweep using step 19 in Table 5-1 and excluding the first and last 40 nanoseconds of the sweep. If necessary, slightly readjust C232 and C272 for one time mark per two divisions.

(5) Disconnect the generator.

u. X Gain (Figure 5-22).

(1) Set controls as follows:

CH 1 VOLTS/DIV	5 m
VERT MODE	CH 2
A AND B TIME/DIV	X-Y
X10 MAG	Out (off)

(2) Connect a calibration generator STD AMPL OUTPUT to the CH 1 input through a 50 ohm BNC cable. Set the generator for a 50 millivolt output.

(3) Adjust X GAIN, R2916 for a 10 division (horizontal) display.

(4) Disconnect the generator.

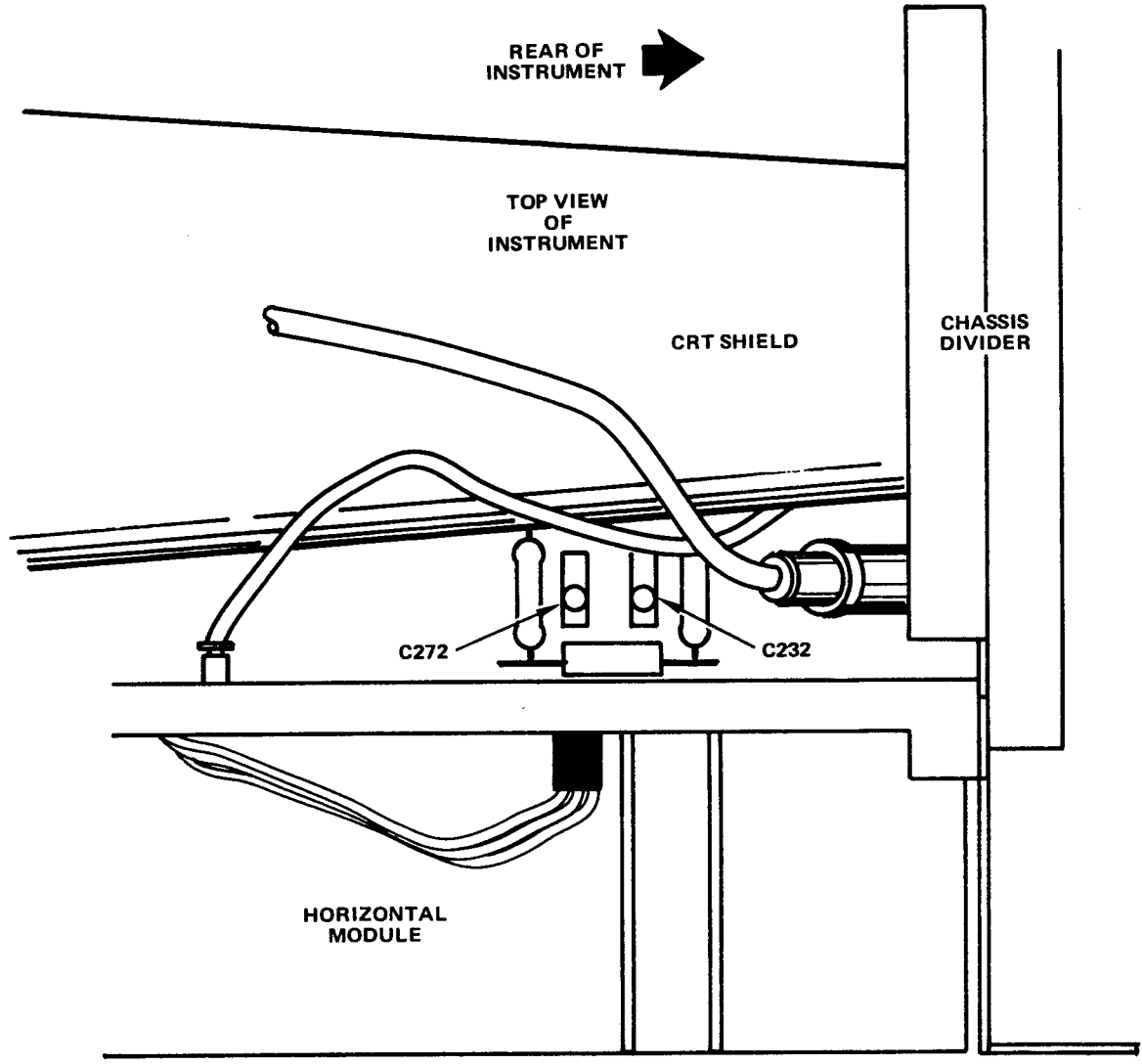

Figure 5-24. 5 nanosecond timing adjustment locations.

SECTION VI DIAGRAMS

6-1. INTRODUCTION. This section contains diagrams and associated data for maintaining the instrument. Included are front and rear panel control, connector, and indicator layouts; schematic diagrams with voltages and waveforms, and circuit board layouts with grid chart component locators.

Capacitors Values one or greater are in picofarads (pF).
 Values less than one are in microfarads (μ F).

Resistors Ohms (Ω).

6-2. ARRANGEMENT.

a. Schematic Diagrams. Schematic diagrams are drawn to group circuit functions; therefore, any one diagram may include portions of any number of circuit boards or assemblies. To aid in tracing circuits from one diagram to another, each diagram is identified with a name and a number in a diamond shaped box. Circuits going from one diagram to another identify the destination component and destination diagram number.

(2) Symbols used on the diagrams are based on ANSI Standard Y32.2-1975.

(3) Logic symbology is based on ANSI Y32.14-1973 in terms of positive logic. Logic symbols depict the logic function performed and may differ from the manufacturer's data.

b. Symbols and Reference Designators.

(1) Electrical components shown on the diagrams are in the following units unless noted otherwise.

(4) Table 6-1 is a partial listing of prefix letters used as reference designators. These are used to identify components or assemblies on the diagrams. A complete listing is contained in MIL STD 16 and also in the ANSI standard referenced in (2) above.

Table 6-1. Reference Designators

REFERENCE DESIGNATOR	DESCRIPTION	REFERENCE DESIGNATOR	DESCRIPTION
A	Assembly, separable or repairable (circuit board, etc.)	LR	Inductor/resistor combination
AT	Attenuator, fixed or variable	M	Meter
B	Motor	P	Connector, movable portion
BT	Battery	Q	Transistor or silicone-controlled rectifier
C	Capacitor, fixed or variable	R	Resistor, fixed or variable
CB	Circuit breaker	RT	Thermistor
CR	Diode, signal or rectifier	S	Switch
DL	Delay line	T	Transformer
DS	Indicating device (lamp)	TC	Thermocouple
E	Spark Gap	TP	Test point
F	Fuse	U	Assembly, inseparable or nonrepairable (integrated circuit, etc.)
FL	Filter	V	Electron tube
H	Heat dissipating device (heat sink, heat radiator, etc.)	VR	Voltage regulator (zener diode, etc.)
HR	Heater	Y	Crystal
HY	Hybrid circuit	Z	Phase shifter
J	Connector, stationary portion		
K	Relay		
L	Inductor, fixed or variable		

(5) An explanation of the symbols used on the diagrams is shown in Figure 6-1.

6-3. WAVEFORMS AND VOLTAGE TEST CONDITIONS.

a. Waveform Conditions. The following test setup is used for all waveforms, except as noted. This uniform setup simplifies troubleshooting. The test oscilloscope trigger setup allows time comparison (horizontally) between the waveforms. Use an AN/USM-425(V)1, Tektronix 465M, or equivalent for waveforms.

(1) Instrument Setup.

(a) Connect a P6104 Probe (10X) to CH 1 input and the probe tip to the CALIBRATOR.

(b) Set the instrument controls as follows:

VOLTS/DIV (both)	.2
AC-GND-DC (both)	DC
VERT MODE	CH 1
HORIZ DISPLAY	MIXED
SOURCE (both)	CH 1
SLOPE (both)	OUT: +
A TIME/DIV	.2 ms
B TIME/DIV	50 μ s
LEVEL (both)	For a stable mixed display

(2) Test Oscilloscope Setup.

(a) Connect a 50 ohm unterminated BNC cable between the A EXT Trigger input of the test oscilloscope and the +A GATE of the oscilloscope under test.

(b) Set the test oscilloscope controls as follows:

A COUPLING	DC
A SLOPE	OUT: +
A SOURCE	EXT \div 10
VERT MODE	CH 1
CH 1 AC-GND-DC	DC
A LEVEL	Adjust so TRIG READY indicator is lit. Push TRIG VIEW to verify triggering on the positive slope.

b. Voltage Conditions. The voltages were taken between the indicated test point and chassis ground using a Tektronix DM 501 digital multimeter. Any change from the following setup may change some of the indicated voltages. Set controls as follows (where controls are duplicated, set both controls the same):

VOLTS/DIV	5 m
AC-GND-DC	GND
POSITION (Vertical)	Midrange
VERT MODE	CH 2
DELAY TIME POS	5.00
HORIZ DISPLAY	A
TIME/DIV	1 ms
POSITION (Horizontal)	Midrange
INTEN	Fully counterclockwise
FOCUS	Fully counterclockwise
SCALE ILLUM	Midrange
TRIG MODE	NORM
COUPLING	AC
SOURCE	CH 1
SLOPE	+
LEVEL	Midrange

NOTE

These settings place the instrument in a quiescent operating state for making dc voltage measurements.

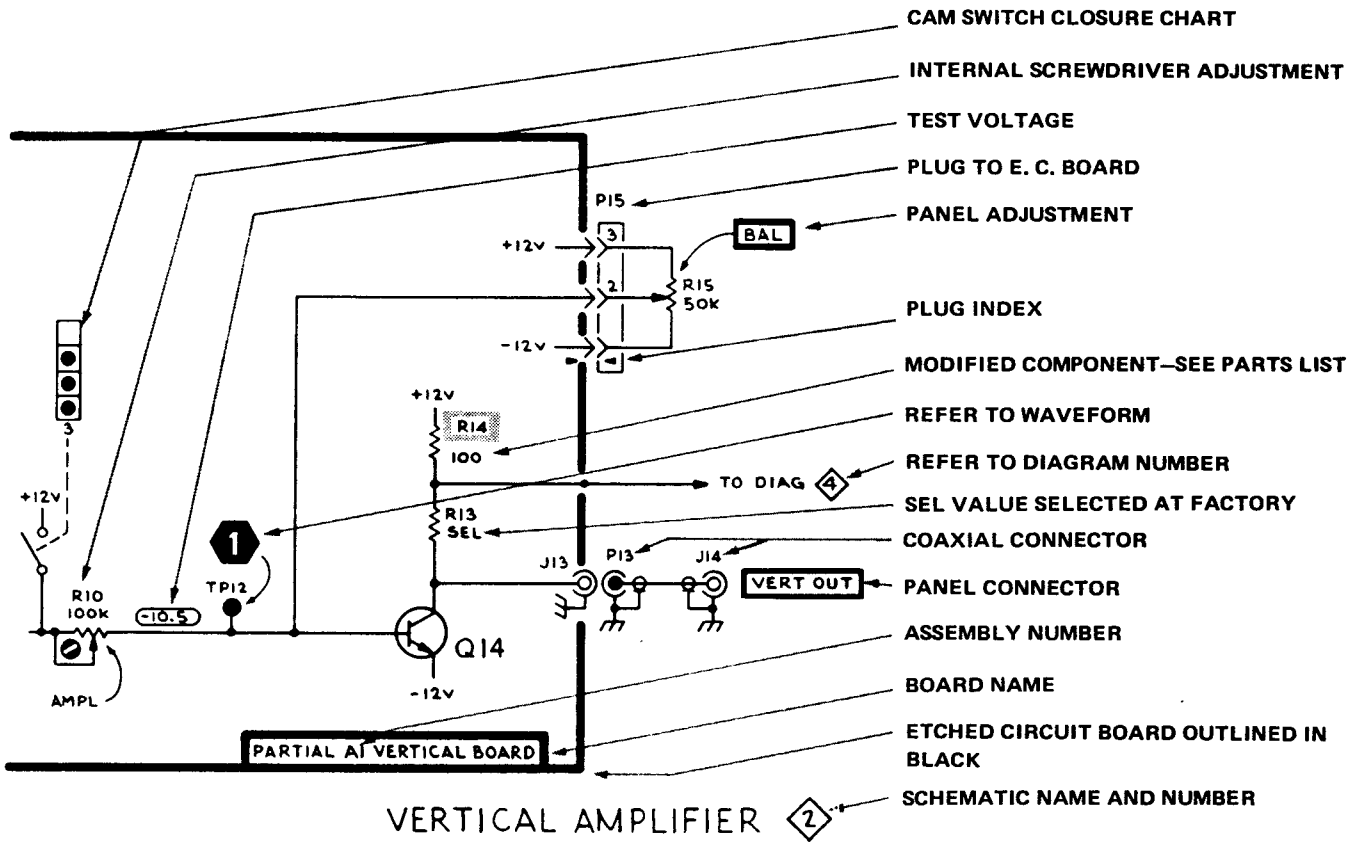

Figure 6-1. Schematic symbols.

SECTION VII

ILLUSTRATED PARTS BREAKDOWN

INTRODUCTION

7.1 GENERAL. The Illustrated Parts Breakdown (IPB) covering the AN/USM-425(V)1 oscilloscope, lists and illustrates the assemblies, subassemblies and detail parts installed at the time the end item(s) was manufactured. If an assembly or part (including vendor items), which is different from the original, is installed during the manufacture of later oscilloscopes, all assemblies and parts will be listed (and "Usable On" coded). However, when the original assembly or part does not have continued application (no spares of the original were procured or such spares are no longer authorized for replacement), only the preferred assembly or part is listed. Interchangeable and substitute assemblies and parts, subsequently authorized by the Government, are not listed in this manual; such items are identified by information available through the Interchangeable and Substitute (I & S) Data Systems. Refer to TO 00-25-184. When a standard size part can be replaced with an oversize or undersize part, the latter parts, showing sizes, are also listed. Repair Parts Kits and Quick Change Units are listed when available. The intended use of the Illustrated Parts Breakdown is for identifying, requisitioning, stocking, and issuing of replacement parts. This IPB is divided into the following sections.

- a. Section VII – Introduction
- b. Section VIII – Maintenance Parts List
- c. Section IX – Numerical Index
- d. Section X – Reference Designation Index

7-2. INTRODUCTION. Section VII includes general information, specific information pertaining to individual sections, directions for use of the IPB, abbreviations, manufacturer's federal supply codes and addresses, and source code definitions.

7-3. MAINTENANCE PARTS LIST INTRODUCTION. Section VIII contains the complete Maintenance Parts List breakdown separated into figures by main groups and assemblies, and keyed to associated illustrations by figure and index numbers. The relation of each part to its next higher assembly, or main group, is shown either by indentation (paragraph 7-4) or by figure cross reference notes (paragraph 7-5).

7-4. INDENTATION. Parts listed in the Maintenance Parts List are indented to indicate item relationship or next higher assembly (NHA). The nomenclature of each assembly is followed in the list (except for attaching parts) by the nomenclature of its components indented one column to the right. This indentation indicates the relationship of the component to the assembly. To determine the next higher assembly of a part or assembly, note the column in which the first word of the nomenclature begins. Then the first item directly above, which appears one column to the left (except for attaching parts), is the next higher assembly.

7-5. FIGURE CROSS REFERENCE NOTES. The continuity of parts breakdown lists and their relationship to the complete assemblies is maintained by a figure cross reference note following the nomenclature of the item being referenced, as follows:

- a. "See figure _____ for breakdown," following the description of a part number indicates that the complete or continued detailed breakdown for the item noted may be found in the referenced figure.
- b. "NHA figure _____," following the description of a part number indicates that the item noted may be found in the figure referenced, with its requirements and relationship to its next higher assembly indicated by column indentation (NHA means next higher assembly).

7-6. SIMILAR ASSEMBLIES. Similar assemblies are combined and listed only once. Common parts are listed with the quantity for one assembly. Peculiar parts are listed and noted with their associated assembly in the description column.

7-7. ATTACHING PARTS. Screws, nuts, bolts, etc., which serve as attaching parts, are listed immediately following, and with the same indentation as the item they attach. They may or may not have an index number assigned. These attaching parts are listed in disassembly sequence and are not considered components of the item that they attach. The abbreviation (AP) following the description of a part identifies that part as an attaching part.

7-8. TEKTRONIX PART NUMBERING SYSTEM. The basic Tektronix part number consists of a three digit category followed by a dash and a four digit body followed by a dash and a two digit suffix. An example is 384-1049-00.

7-9. EXPLANATION OF COLUMNS IN SECTION VIII. The following columns have this data included within the limits of the format.

a. **Figure and Index Number.** This column references the part list entry to its location in the illustration.

b. **Part Number.** Any of the following may be found entered in this column.

(1) Manufacturer's part number which is related to the five digit code in the FSCM column.

(2) "-----" is used to designate a part procurable only as part of the next higher assembly.

c. **FSCM.** These codes are a five digit manufacturer's assigned code associated with the manufacturer of the part. A cross reference list, code to name is located in paragraph 7-15.

d. **Description.** This column will contain the nomenclature and a short description of each part listed. The notation (80009 No. xxx-xxxx-xx) indicates the Tektronix FSCM code and part number of the item.

e. **Units Per Assembly.** The following types of entries are noted in this column.

(1) The quantity required to make up one higher assembly.

(2) "REF" means "reference" and is used to indicate that the item has been accounted for elsewhere in the Maintenance Parts List.

(3) "AR" means "as required" and is used to designate lengths noted in the description column of special cables.

f. **Usable On Code.** The code letters appearing in this column indicate usability of replacement parts when more than one article is covered in the parts list. Absence of a code letter opposite a part indicates that the part is usable on all articles.

7-10. NUMERICAL INDEX INTRODUCTION. Section IX provides a complete cross reference by means of the part number, listed and arranged in alphanumerical sequence. The order of precedence in beginning the part number arrangement on the extreme left hand (first) posi-

tion of the part number is as follows:

Letters "A" through "Z"

Numerals "0" through "9"

a. The order of precedence in continuing the alphanumerical arrangement in the second and succeeding positions of the number from left to right is as follows:

Space (blank column)

Diagonal (slant) /

Point (period).

Dash (hyphen)-

Letters "A" through "Z"

Numerals "0" through "9"

b. Alphabetical "0's" shall be considered as numerical "zeros." Spaces, diagonals, points, and dashes do not appear in the extreme left hand position of the part number; however, they may be used in the second and succeeding position of the part number and take precedence over letters and numerals as indicated above.

7-11. SOURCE, MAINTENANCE, AND RECOVERABILITY (SMR) CODE. SMR definitions are set forth in T.O. 00-25-195. Codes were not available for insertion in the SMR column herein as of the publication date of this manual.

7-12. REFERENCE DESIGNATION INDEX INTRODUCTION. Section X contains an alphanumerical listing for all Reference Designators assigned to electrical components listed by figure and index number in the Maintenance Parts List. Reference Designators have been assigned to electrical components in compliance with MIL-STD-16. They appear in diagrams of electrical and electronic circuits and assist in correlating graphic symbols shown thereon with parts list, descriptions, and part numbers.

7-13. HOW TO USE THIS IPB. For an explanation of how to identify a part whether the part number is or is not known see Figure 7-1.

7-14. ABBREVIATIONS AND LETTER SYMBOLS LIST. The following is a list of abbreviations and symbols used throughout this technical order in compliance with Military Standard MIL-STD-12:

Abbreviation	Term
A	Ampere
AC	Alternating Current
AWG	American Wire Gage

Abbreviation	Term	Code	Manufacturer's Name and Address
BDGH	Binding Head	00853	Sangamo Electric Co., S. Carolina Division P. O. Box 128 Pickens, SC 29671
BSHG	Bushing		
DC	Direct Current		
DIA	Diameter		
FEM	Female		
MW	Megawatt	01121	Allen-Bradley Co. 1201 2nd Street South Milwaukee, WI. 53204
NA	Nanoamperes		
NE	Neon		
NHA	Next Higher Assembly		
NPN	Negative-Positive-Negative (transistor)	01295	Texas Instruments Inc., Semiconductor Group P. O. Box 5012, 13500 N. Central Expressway Dallas, TX 75222
NPO	Negative-Positive-Zero		
OD	Outside Diameter		
FET	Field-Effect Transistor		
FILH	Fillister Head		
FLH	Flat Head		
FT	Foot		
H	High	02735	RCA Corp. Solid State Division Route 202 Somerville, NJ 08876
HEX HD	Hexagonal Head		
HEX	Hexagon		
HV	High Voltage		
ID	Inside Diameter	03888	KDI Pyrofilm Corp. 60 S. Jefferson Road Whippany, NJ 07981
IN	Inch		
K	Kilo		
L	Length		
M	Mega	04713	Motorola Inc., Semiconductor Products Division P. O. Box 20923 5005 E. McDowell Road Phoenix, AZ 85036
MA	Milliampere		
MAX	Maximum		
MTG	Mounting		
PA	Picoamperes		
PF	Picofarad		
PIV	Peak Inverse Voltage		
PNH	Pan Head	05129	Kilo Engineering Co. 2015 D LaVerne, CA 91750
PNP	Positive-Negative-Positive (transistor)		
RPM	Revolution Per Minute		
SQ	Square		
SST	Stainless Steel	05276	ITT Pomona Electronics Division P. O. Box 2767 1500 E. 9th Street Pomona, CA 91766
STL	Steel		
THK	Thick		
UA	Microampere		
UF	Microfarad		
UH	Microhenry	05397	Union Carbide Corp., Materials Systems Division 11901 Madison Ave. Cleveland, OH 44101
V	Voltage		
W	Watt or Wide		

7-15 MANUFACTURER'S CODE CROSS REFERENCE LIST. The following list is a cross reference, code to name and address, of manufacturers supplying items or assemblies. These are the codes contained in Government publication, "Code for Manufacturers Handbook H4-1."

Code	Manufacturers Name and Address	Code	Manufacturer's Name and Address
00779	Amp Inc. P. O. Box 3608 Harrisburg, PA 17105	07263	Fairchild Camera and Instrument Corp., Semiconductor Division 464 Ellis Street Mountain View, CA 94042
		07700	Technical Wire Products Inc. 129 Dermody Street Cranford, NJ 07016

AIR FORCE TO33A1-13-496-1
NAVELEX 0969-LP-170-0010
Introduction to IPB

Code	Manufacturer's Name and Address	Code	Manufacturer's Name and Address
07910	Teledyne Semiconductor 12515 Chadron Ave. Hawthorne, CA 90250	32997	Bourns Inc., Trimpot Products Division 1200 Columbia Ave. Riverside, CA 92507
08261	Spectra-Strip Corp. 7100 Lampson Ave. Garden Grove, CA 92642	36619	Microwave Industries and Components Inc. 6600 Bombardier Street Montreal Que, CAN H1P 1E4
08806	General Electric Co., Miniture Lamp Products Dept. Nela Park Cleveland, OH 44112	50157	Midwest Components Inc. P. O. Box 787 1981 Port City Blvd. Muskegon, MI 49443
09353	C and K Components Inc. 103 Morse Street Watertown, MA 02172	50437	Reliance Steel Products Co. 3700 Walnut Street McKeesport, PA 15132
12697	Clarostat Mfg., Co., Inc. Lower Washington Street Dover, NH 03820	56289	Sprague Electric Co. North Adams, MA 01247
15454	Rodan Industries Inc. 2905 Blue Star Street Anahiem, CA 92806	59730	Thomas and Betts Co. 36 Butler Street Elizabeth, NJ 07207
15818	Teledyne Semiconductor 1300 Terra Bella Ave. Mountain View, CA 94043	70485	Atlantic India Rubber Works Inc. 571 W. Polk Street Chicago, IL 60607
19396	Illinois Tool Works Inc., Paktron Division 900 Follin Lane S. E. Vienna, VA 22180	71286	Rexnord Inc., Speciality Fastener Division 22 Spring Valley Road Paramus, NJ 07652
22526	Berg Electronix Inc. Youk Expressway New Cumberland, PA 17070	71400	Bussmann Mfg., Division McGraw-Edison Co. 2536 W. University Street St. Louis, MA 63107
23499	Gavitt Wire and Cable, Division of RSC Industries Inc. 455 Quince Street Escondido, CA 92025	71590	Centralab Electronics, Division of Globe-Union Inc. P. O. Box 858, Hwy 20 W. Fort Dodge, IA 50501
24931	Specialty Connector Co., Inc. 3560 Madison Ave. Indianapolis, IN 46227	72982	Erie Technological Products Inc. 644 W. 12th Street Erie, PA 16512
27264	Molex Products Co. 5224 Katrine Ave. Downers Grove, IL 60515	73138	Beckman Industries Inc., Helipot Division 2500 Harbor Blvd. Fullerton, CA 92634
28480	Hewlett-Packard Co., Corporate Hq. 1501 Page Mill Road Palo Alto, CA 94304	73743	Fischer Special Mfg., Co. 446 Morgan Street Cincinnati, OH 45206

Code	Manufacturer's Name and Address	Code	Manufacturer's Name and Address
73803	Texas Instruments Inc., Metallurgical Materials Division 34 Forest Street Attleboro, MA 02703	81483	International Rectifier Corp. 9220 Sunset Blvd. Los Angeles, CA 90069
74868	Bunker Ramo Corp., Amphenol RF Division 33 E. Franklin Street Danbury, CT 06810	83501	Gavitt Wire and Cable Division of RSC Industries Inc. Central Street Brookfield, MA 01506
74970	Johnson E. F. Co. 299 10th Ave., S. W. Washeca, MN 56093	86928	Seastrom Mfg. Company, Inc. 701 Sonora Ave. Glendale, CA 91201
75042	TRW Electronic Components, IRC Fixed Resistors Philadelphia Division 401 N. Broad Street Philadelphia, PA 19108	90201	Mallory Capacitor Co., Division of P.R. Mallory and Co., Inc. P. O. Box 372 3029 E. Washington Street Indianapolis, IN 46206
75915	Littlefuse Inc. 800 E. Northwest Hwy. Des Plaines, IL 60016	91637	Dale Electronics Inc. P. O. Box 609 Columbus, ME 68601
76493	Bell Industries Inc., Miller J. W. Division P. O. Box 5825 19070 Reyes Ave. Compton, CA 90224	91737	ITT Cannon-Gremar Inc. 922 S. Lyon Street Santa Ana, CA 92705
78189	Illinois Tool Works Inc., Shakeproff Division St. Charles Road Elgin, IL 60120	91929	Honeywell Inc., Micro Switch Division 11 W. Spring Street Freeport, IL 61032
78488	Stackpole Carbon Co. St. Marys, PA 15857	93410	Essex Group Inc., Controls Division, Lexington Plant P. O. Box 1007 45-55 Plymouth Street Lexington, OH 44967
79136	Waldes Kohinoor Inc. 47-16 Austel Place Long Island City, NY 11101	95712	Bendix Corp., The Electrical Components Division Microwave Devices Plant Hurricane Road Franklin, IN 46131
80009	Tektronix Inc. P. O. Box 500 Beaverton, OR 97077	95987	Weckesser Co., Inc. 4444 West Irving Park Road Chicago, IL 60641
80031	Mepco-Electa Inc. 22 Columbia Road Morristown, NJ 07960	98003	Nielson Hardware Corp. P. O. Box 568 770 Wethersfield Ave. Hartford, CT 06101
80294	Bourns Inc., Instrument Division 6135 Magnolia Ave. Riverside, CA 92506	98291	Sealectro Corp. 225 Hoyt Mamaroneck, NY 10544

HOW TO USE THE ILLUSTRATED PARTS BREAKDOWN

IF YOU Don't KNOW THE PART NUMBER ...

Do This

AIR FORCE TO33A1-13-496-1
NAVELEX 0969-LP-170-0010

LIST OF ILLUSTRATIONS (cont)

Figure	Title	Page	Figure	Title	Page
FC 8 (cont)	Horizontal Amplifier - Gate and Cathode schematic diagram 2	618	87	Circuit Board Assembly, Horizontal Mixer	626
FC 9 (cont)	Part of A13 Intermediate circuit board layout and component locator	620	88	Circuit Board Assembly, Trigger (sheet 1 of 3)	630
FC 9 (cont)	Gate and Z Axis schematic diagram 8	621	88	Circuit Board Assembly, Trigger (sheet 2 of 3)	631
FC 9 (cont)	Part of A13 Intermediate circuit board layout and component locator	622	88	Circuit Board Assembly, Trigger (sheet 3 of 3)	632
FC 10 (cont)	Power Supply and Mixer Control schematic diagram 8	623	89	Circuit Board Assembly, A (sheet 1 of 2)	636
FC 11 (cont)	Intermediate Mixer schematic diagram 10	625	89	Circuit Board Assembly, B (sheet 1 of 2)	638
FC 12 (cont)	PS101 and PS104 Power Schematic diagram 11	627	910	Circuit Board Assembly, Horizontal Mixer	640
81	Decoupler - AN USM 425W1	610	811	Circuit Board Assembly, Mixer	640
82	Accessories and Cam Assembly	62	811		
83	Cabinet and Handle Assembly	65			
84	Circuit Board Assembly, Vertical Mixer	67			
85	Circuit Board Assembly, Vertical (sheet 1 of 4)	67	812		
85	Circuit Board Assembly, Vertical (sheet 2 of 4)	67	813		
85	Circuit Board Assembly, Vertical (sheet 3 of 4)	67	814		
85	Circuit Board Assembly, Vertical (sheet 4 of 4)	67	814		
86	Control Panel Assembly, Cam Switch Channel 2	67	814		

1 Refer to illustration list and select the illustration most likely to contain the desired part.

2 Refer to the page number indicated and find desired part on illustration.

3 Note the Figure Number of the illustration and the Index Number of the part. Refer to the corresponding Figure-Index Number for Part Number, Nomenclature etc.

6 Circuit Board Assembly, Cam Switch Channel 2 (sheet 2 of 2) ... 82

LIST OF TAB

Number	Title	Page	Number
1	Electrical Characteristics	12	42
2	Environmental Characteristics	17	
3	Physical Characteristics	18	
21	Test Equipment List	51	
22	Component Materials List	53	
		54	
41	Attachments and Cam Switching Sequence	45	61

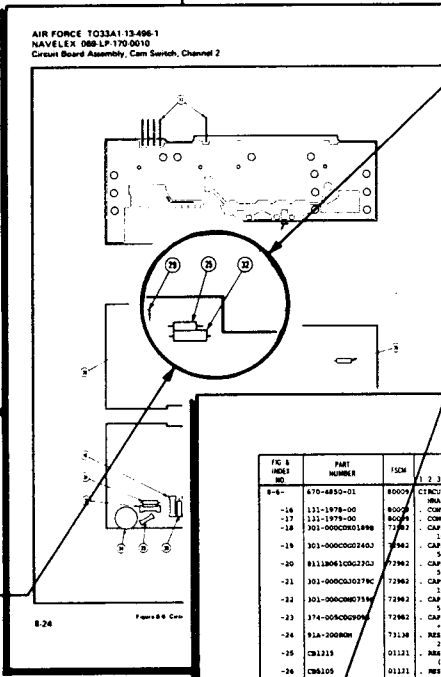

3 If illustration of part is desired - refer to same Figure and Index Number on accompanying illustration.

AIR FORCE TO33A1-13-496-1
NAVELEX 0969-LP-170-0010
Circuit Board Assembly, Cam Switch, Channel 2

FIG & INDEX NO	PART NUMBER	ISCM	DESCRIPTION	UNITS PER ASSY	USABLE ON CODE
8-6	470-8850-01	80000	CIRCUIT BOARD ASSEMBLY, Cam Switch, Channel 2, 1.	REF	
			MMA Figure 4-96		
-16	131-1978-00	80000	CONTACT, ELECTRICAL, circuit board for whake...	2	
-17	131-1978-00	80000	CONTACT, ELECTRICAL, make to 415 load term...	5	
-18	301-0000001996	72962	CAPACITOR, FIXED, CERAMIC DIELECTRIC, 1.0pf, 50...	1	
-19	301-0000002463	72962	CAPACITOR, FIXED, CERAMIC DIELECTRIC, 22pf, 50...	1	
			SOV (GROUP No. 381-057-00)		
-20	8118041062252	72962	CAPACITOR, FIXED, CERAMIC DIELECTRIC, 22pf, 50...	1	
-21	301-0000003290	72962	CAPACITOR, FIXED, CERAMIC DIELECTRIC, 1.7pf, 50...	1	
-22	301-0000007398	72962	SOV (GROUP No. 381-057-00)		
			CAD		
-23	374-000000096	72962	CAD		
-24	91A-300808	72134	RZ2		
-25	CM1315	01321	RES		
-26	CM105	01321	RES		
-27	881055	01321	RES		
-28	883009	01321	RES		
-29	MFF1816G15080D	91637	RES		
-30	MFF1816G20080	91637	RES		

2 Turn to Figure and Index Number indicated to obtain desired information.

AIR FORCE TO33A1-13-496-1
NAVELEX 0969-LP-170-0010
Numerical Index

PART NUMBER	FIG & INDEX NO	QTY PER ASSY	USABLE ON CODE	PART NUMBER	FIG & INDEX NO	QTY PER ASSY	USABLE ON CODE
MFF1816G30080	8-4-30	1		86079	8-5-7	1	
MFF1816G3100F	14-144	1		TEX-171-0827-00	7-49	AP	
MFF1816G32100F	13-78	1		TEX-175-0828-00	7-56	AP	
MFF1816G3300F	13-77	1		TEX-175-0829-00	4-102	AP	
MFF1816G3490F	14-145	1		TEX-175-0830-00	7-70		
MFF1816G3500F	10-27	1		TEX-175-0831-00	12-86	AP	
MFF1816G36700F	8-55	12		711C259075AA	14-73	1	
MFF1816G3800F	5-110	4			4-37	1	
MFF1816G39400F	5-113	2		UG2788DURAFLATE	2-2	1	
MFF1816G4000F	5-115	2		05C-162-100	7-18	1	
MFF1816G41800F	5-112	2		000-201-4996	16-164	2	
MFF1816G42800F	5-113	2		010-0101-000	7-6	1	
MFF1816G43800F	5-112	2		010-0106-000	2-14	1	
MFF1816G45300F	5-113	2		013-0107-01	2-47	2	
MFF1816G46300F	13-78	1		013-0203-01	2-46	2	
MFF1816G4700F	5-118	1		013-0201-01	2-16	1	
MFF1816G4800F	5-96	1		010-0123-00	2-4	1	
MFF1816G4900F	5-97	1		08-54-0103	11-97	9	
MFF1816G5000F	5-114	3		08-50-0021	12-90	3	
MFF1816G51800F	5-98	1		1-380949-6	9-16	4	
MFF1816G52800F	5-115	2		1-380949-6	9-25	3	
MFF1816G5300F	14-139	1		1-380949-6	10-40	1	
MFF1816G54300F	11-79	1		1-380949-6	9-17	3	
MFF1816G5500F	14-147	1		1-380949-6	10-41	1	
MFF1816G56800F	5-99	3		1-380949-9	10-42	2	
MFF1816G5700F	5-116	1		1-488275-0	13-84	4	
MFF1816G58300F	14-140	1		108104-4-230C	5-42	1	
MFF1816G5900F	14-141	1		1200348	14-27	1	
MFF1816G6100F	11-80	1		148238A	14-31	2	
MFF1816G62800F	3-29	1		1M132	9-15	99	
MFF1816G6300F	5-100	2		1M132	8-5		
MFF1816G63800F	14-133	1		1M132	11-4		
MFF1816G64300F	14-134	1		1M132	14-24		
MFF1816G64800F	5-101	2		1M135	14-33	2	
MFF1816G6500F	14-135	1		1M137	14-39	1	
				1M138	14-37	1	
				1M139	14-26	1	
				1M140	14-32	1	
				1M141	14-29	1	
				1M142	14-30	1	
				103-0051-01	2-45	3	
				103-0186-01	7-28	3	
				103-0186-02	4-26	2	
				103-0186-03	7-24	2	
				103-0420-00	5-121	1	
				103-0421-00	5-120	1	
				103-0422-00	5-128	1	
				103-0423-00	5-123	1	

IF YOU DO KNOW THE PART NUMBER ...

Do This

1 Find the Part Number in the Numerical Parts List. Note the Figure and Index Number where the part is called out in Parts List.

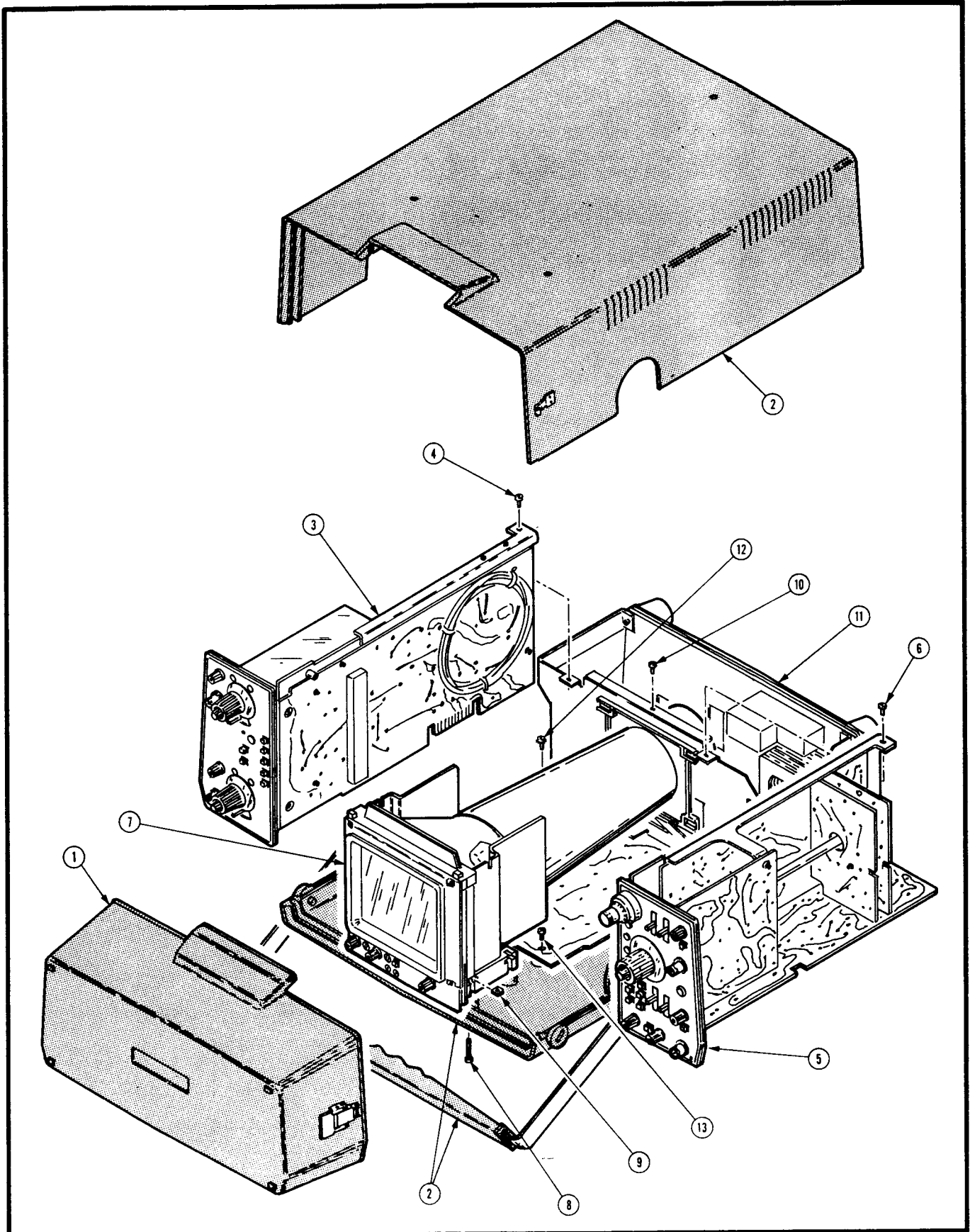

Figure 8-1. Oscilloscope, AN/USM-425(V)1.

SECTION VIII ILLUSTRATED PARTS BREAKDOWN MAINTENANCE PARTS LIST

FIG. & INDEX NO.	PART NUMBER	FSCM	DESCRIPTION							UNITS PER ASSY	USABLE ON CODE
			1	2	3	4	5	6	7		
8-1-	-----	80009	OSCILLOSCOPE,100MHZ,AN/USM-425 (V)1.....							1	
-1	-----	80009	. ACCESSORY AND COVER ASSEMBLY,See Figure 2... for Breakdown							1	
-2	-----	80009	. CABINET AND HANDLE ASSEMBLY,See Figure 3.... for Breakdown							1	
-3	672-0615-00	80009	. CIRCUIT BOARD ASSEMBLY,Vertical Module,..... See Figure 4 for Breakdown							1	
-4	211-0503-00	80009	. SCREW,MACHINE,6-32 X 0.188 inch,pnh,steel... (AP)							2	
-5	672-0613-00	80009	. CIRCUIT BOARD ASSEMBLY,Horizontal Module,... See Figure 7 for Breakdown							1	
-6	211-0503-00	80009	. SCREW,MACHINE,6-32 X 0.188 inch,pnh,steel... (AP)							2	
-7	-----	80009	. ELECTRON TUBE ASSEMBLY,See Figure 12 for.... Breakdown							1	
-8	211-0516-00	80009	. SCREW,MACHINE,6-32 X 0.875 inch,pnh,steel... (AP)							4	
-9	220-0419-00	80009	. NUT,PLAIN,SQUARE,6-32 X 0.312 inch,steel.... (AP)							4	
-10	211-0143-00	80009	. SCREW,MACHINE,4-40 X 0.375 inch,pnh,steel... (AP)							1	
-11	-----	80009	. MAIN CHASSIS ASSEMBLY,See Figure 13 for..... Breakdown							1	
-12	211-0534-00	80009	. SCREW,ASSEMBLED,WASHER,6-32 X 0.312 inch,pnh steel (AP)							4	
-13	211-0504-00	80009	. SCREW,MACHINE,6-32 X 0.25 inch,pnh,steel.... (AP)							5	

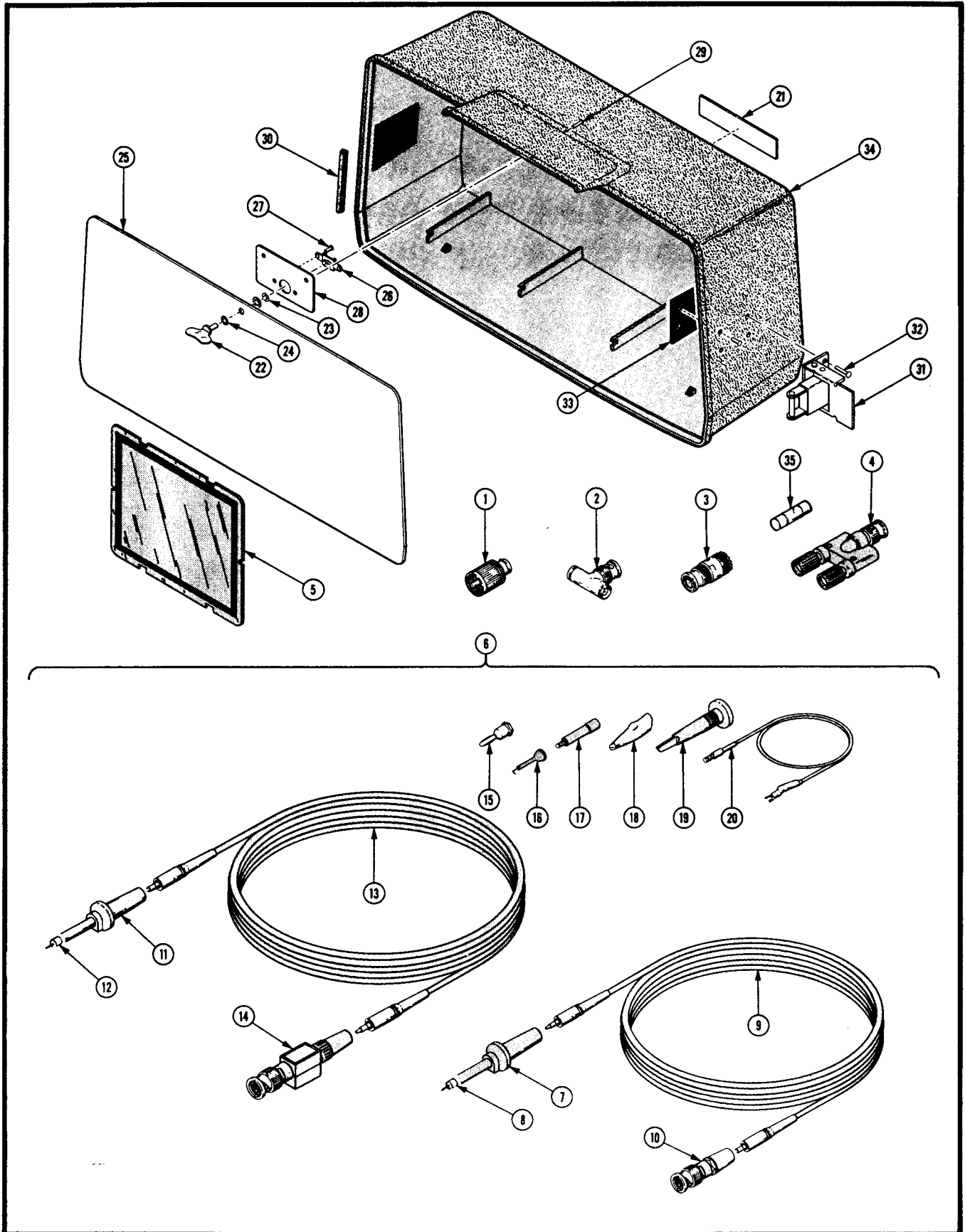

Figure 8-2. Accessories and Cover Assembly.

FIG. & INDEX NO.	PART NUMBER	FSCM	DESCRIPTION							UNITS PER ASSY	USABLE ON CODE
			1	2	3	4	5	6	7		
8-2-	-----	80009	ACCESSORY AND COVER ASSEMBLY, NHA Figure 1-1...							REF	
-1	470-3NT34	95712	. ADAPTER, CONNECTOR, BNC TO UHF (80009 No. 103-0015-00)							2	
-2	UG274BUDURAPLATE	91737	. ADAPTER, CONNECTOR, BNC TO BNC (80009 No. 103-0030-00)							1	
-3	29-JP116-1	24931	. ADAPTER, CONNECTOR, BNC male to UHF female.... (80009 No. 103-0032-00)							2	
-4	1296	05276	. ADAPTER, CONNECTOR, BNC male to dual binding.. post (80009 No. 103-0035-00)							1	
-5	337-2122-00	80009	. SHIELD, IMPLOSION, blue.....							1	
	337-2122-01	80009	. SHIELD, IMPLOSION, clear.....							1	
-6	020-0233-00	80009	. ACCESSORY PACKAGE, with probes.....							1	
	010-6101-00	80009	. . LEAD, TEST, 1 X 1 meter.....							1	
-7	206-0223-00	80009	. . . PROBE HEAD, 1X.....							1	
-8	206-0191-01	80009 TIP, PROBE, package of 10.....							1	
-9	175-1661-00	80009	. . . CABLE, SPECIAL PURPOSE, ELECTRICAL, 39 ohm. coax, 40.72 long							1	
-10	28PR224-1	24931	. . . ADAPTER, CABLE END (80009 No. 103-0189-00)							1	
	010-6104-00	80009	. . LEAD, TEST, 10X, 1 meter.....							2	
-11	206-0224-00	80009	. . . PROBE HEAD, 1 meter, blue.....							1	
-12	206-0191-01	80009 TIP, PROBE, package of 10.....							1	
-13	175-1661-00	80009	. . . CABLE, SPECIAL PURPOSE, ELECTRICAL, 39 ohm. coax, 40.72 long							1	
-14	206-0244-00	80009	. . . COMPENSATION BOX, 1 meter blue.....							1	
-15	108-753-17	74970	. . PROBE, TIP (80009 No. 134-0013-00).....							3	
-16	206-0105-00	80009	. . TIP, PROBE.....							3	
-17	103-0051-01	80009	. . ADAPTER, PROBE TIP.....							3	
-18	344-0046-00	80009	. . CLIP, ELECTRICAL, alligator type, with cover.							3	
-19	013-0107-03	80009	. . TIP, TEST PROD, retainer hook assembly.....							3	
-20	175-0124-01	80009	. . LEAD, ELECTRICAL, probe ground, 5 inches.... long							3	
	200-2055-01	80009	. COVER, SCOPE, with hardware.....							1	
-21	334-2661-00	80009	. . PLATE, IDENTIFICATION, marked Tektronix.....							1	
-22	5S10-8	71286	. . FASTENER, PAWL (80009 No. 214-0122-00).....							1	
-23	5S3-1	71286	. . WASHER, RING, 0.25 inch OD (80009 No. 210-0907-00) (AP)							1	
-24	210-1105-00	80009	. . WASHER, FLAT, 0.188 ID X 0.375 inch OD, nylon (AP)							1	
-25	200-2056-00	80009	. . LID, ACCESSORY COVER.....							1	
-26	5R2-1	71286	. . RECEPTACLE, FASTENER (80009 No. 214-0127-00)							1	
-27	210-0622-00	80009	. . RIVET, SOLID (AP).....							2	
-28	386-3689-00	80009	. . SUPPORT, COVER.....							1	
-29	210-3068-00	80009	. . RIVET, TUBULAR, 0.218 L X 0.125 OD, truss.... head, brass (AP)							2	
-30	348-0524-00	80009	. . GASKET, FRONT PANEL, silicone with PSA back.							1	
-31	CB-83314-CE	98003	. . CATCH, CLAMPING, front cover (80009 No. 105-0350-00)							2	
-32	210-3067-00	80009	. . RIVET, TUBULAR, 0.281 L X 0.125 OD, truss.... head, brass (AP)							4	

AIR FORCE TO33A1-13-496-1
 NAVELEX 0969-LP-170-0010
 Accessories and Cover Assembly

FIG. & INDEX NO.	PART NUMBER	FSCM	DESCRIPTION							UNITS PER ASSY	USABLE ON CODE	
			1	2	3	4	5	6	7			
8-2-	210-3068-00	80009	.	.	RIVET,TUBULAR,0.218 L X 0.125 OD,truss....						4	
					head,brass (AP)							
-33	386-2275-00	80009	.	.	PLATE,BACKING,cover latch.....						2	
-34	200-2055-00	80009	.	.	COVER,SCOPE,front.....						1	
-35	AGC1/2	71400	.	.	FUSE,CARTRIDGE,3AG,0.5A,250V,fast-blow.....						1	
					(80009 No. 159-0025-00)							

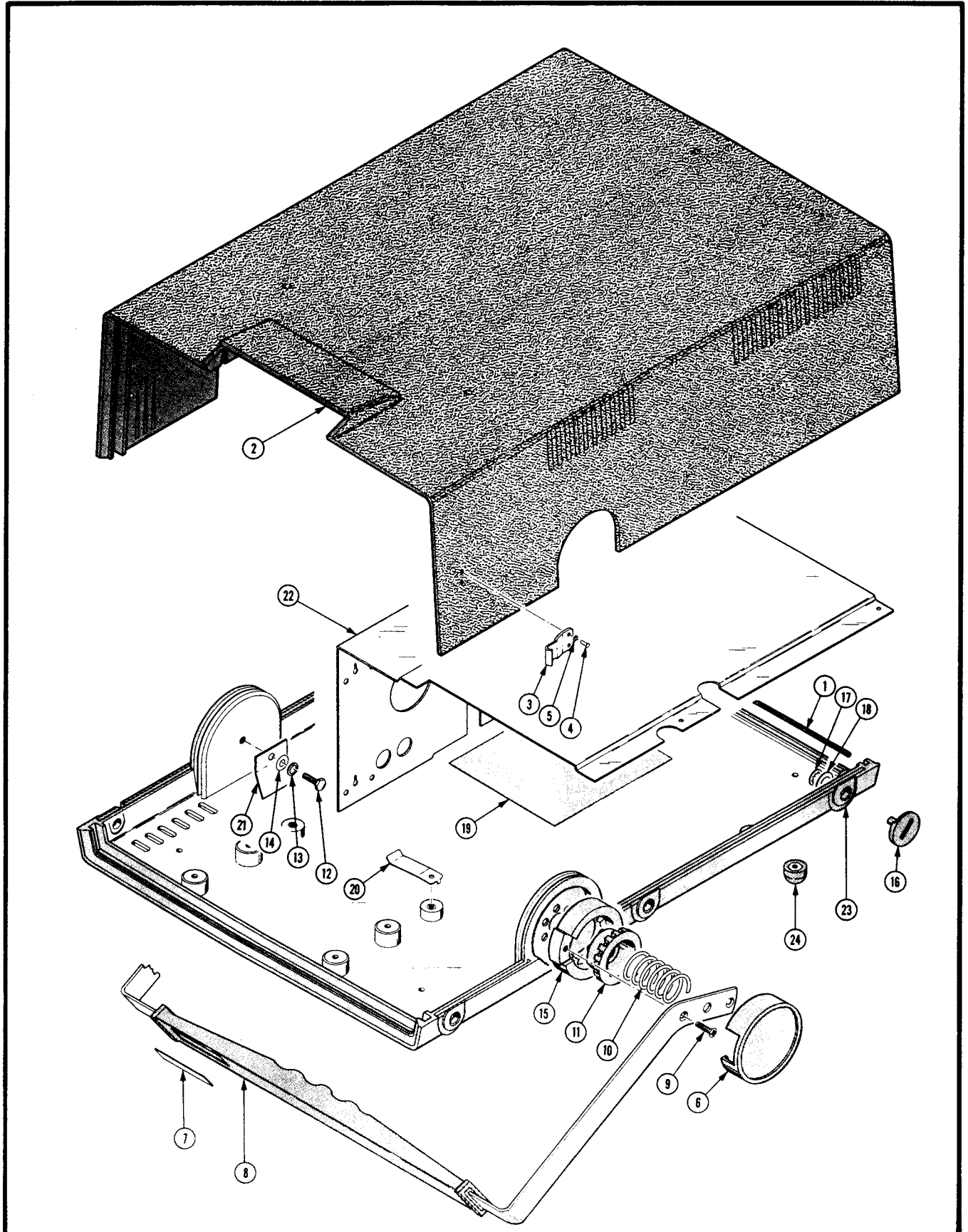

Figure 8-3. Cabinet and Handle Assembly.

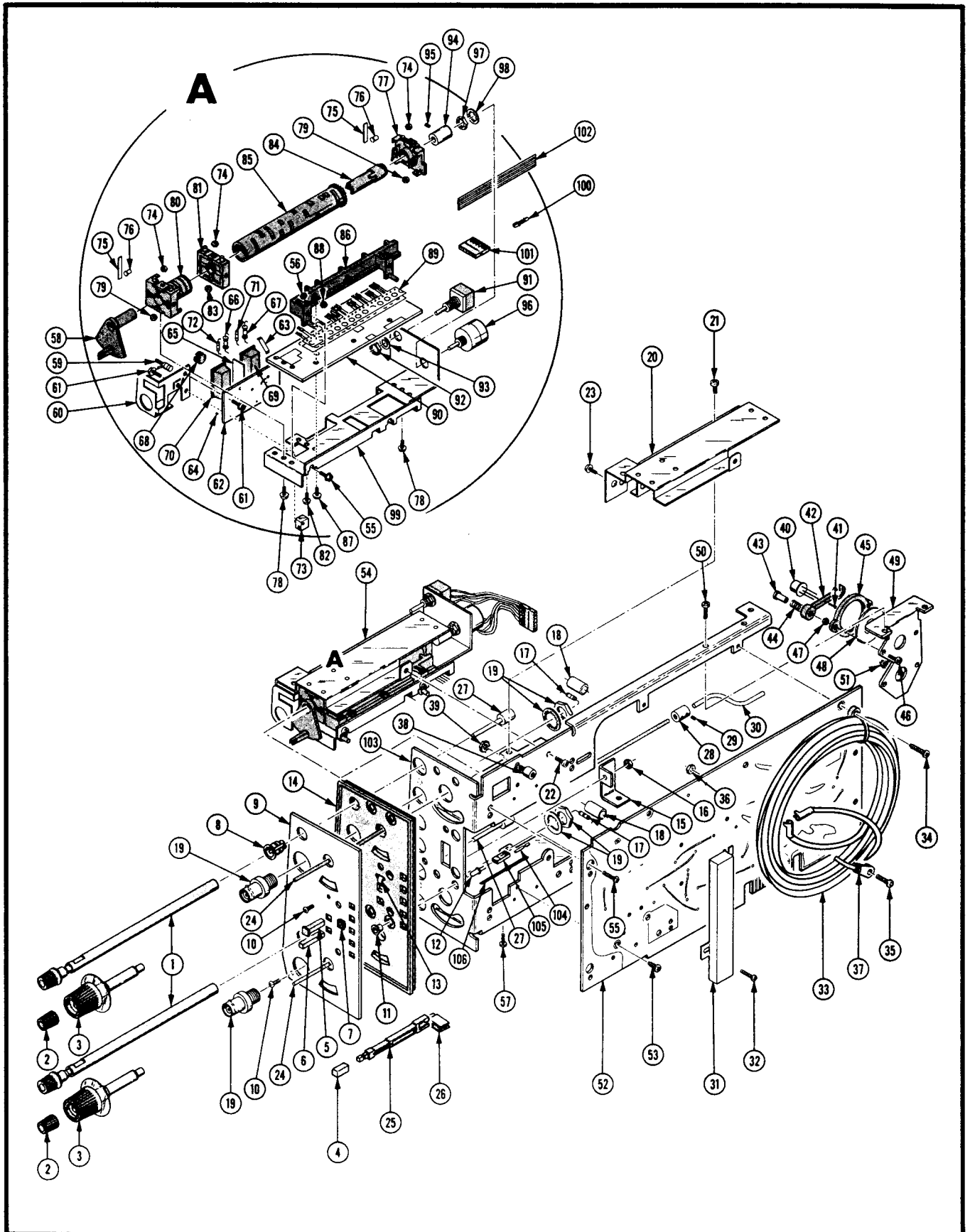

Figure 8-4. Circuit Board Assembly, Vertical Module.

FIG. & INDEX NO.	PART NUMBER	FSCM	DESCRIPTION							UNITS PER ASSY	USABLE ON CODE															
			1	2	3	4	5	6	7																	
8-4-31	337-2234-00	80009	.	S	H	I	E	L	D,ELECTRICAL,preamplifier input.....	1																
-32	211-0012-00	80009	.	S	C	R	E	W,MACHINE,4-40 X 0.375 inch,pnh,steel... (AP)	3																	
-33	119-0860-00	80009	.	D	E	L	A	Y,L1NE,120NS,150 ohm.....	1																	
-34	213-0183-00	80009	.	S	C	R	E	W,TAPPING,THREAD FORMING,6-32 X 0.25... inch,pnh,steel (AP)	2																	
-35	211-0510-00	80009	.	S	C	R	E	W,MACHINE,6-32 X 0.312 inch,pnh,steel... (AP)	1																	
-36	3038-0228-402	73743	.	N	U	T,PLAIN,HEXAGON,6-32 X 0.25 inch,brass.... (AP) (80009 No. 210-0409-00)	1																			
-37	T4-34M	59730	.	S	T	R	A	P,ELECTRICAL COMPONENT,tie down,5.0... inch long (80009 No. 346-0121-00)	3																	
-38	129-0575-00	80009	.	S	P	A	C	E	R,POST,0.312 inch long with 6-32..... threads,brass	1																
-39	210-0457-00	80009	.	N	U	T,PLAIN,EXTENDED WASHER,6-32 X 0.312 inch, steel (AP)	1																			
-40	151-0446-00	80009	.	T	R	A	N	S	I	S	T	O	R,silicon,NPN.....	2												
-41	210-0627-00	80009	.	R	I	V	E	T,SOLID,0.042 OD X 0.25 inch long,RDH...	2																	
-42	343-0097-00	80009	.	R	E	T	A	I	N	E	R,TRANSISTOR,heat sink.....	2														
-43	210-0599-00	80009	.	N	U	T,SLEEVE,4-40 X 0.391 inch long (AP).....	4																			
-44	214-0368-00	80009	.	S	P	R	I	N	G,HELICAL COMPRESSION,0.24 OD X 0.438.. inch long	2																
-45	352-0262-00	80009	.	R	E	T	A	I	N	E	R,TRANSISTOR.....	2														
-46	211-0012-00	80009	.	S	C	R	E	W,MACHINE,4-40 X 0.375 inch,pnh,steel... (AP)	4																	
-47	2X12161-402	73743	.	N	U	T,PLAIN,HEXAGON,4-40 X 0.188 inch,brass... (AP) (80009 No. 210-0406-00)	4																			
-48	214-1138-00	80009	.	H	E	A	T	S	I	N	K,ELECTRICAL,transistor,1 inch OD,.. aluminum	2														
-49	407-1922-00	80009	.	B	R	A	C	K	E	T,HEAT SINK,transistor,aluminum.....	1															
-50	211-0507-00	80009	.	S	C	R	E	W,MACHINE,6-32 X 0.312 inch,pnh,steel... (AP)	2																	
-51	210-0457-00	80009	.	N	U	T,PLAIN,EXTENDED WASHER,6-32 X 0.312 inch, steel (AP)	2																			
-52	670-4849-00	80009	.	C	I	R	C	U	I	T	B	O	A	R	D	A	S	S	E	M	B	L	E	Y,Vertical,See Figure 5 for Breakdown	1	
-53	213-0146-00	80009	.	S	C	R	E	W,TAPPING,THREAD FORMING,6-20 X 0.313... inch,pnh,steel (AP)	2																	
-54	672-0616-00	80009	.	C	I	R	C	U	I	T	B	O	A	R	D	A	S	S	E	M	B	L	E	Y,Attenuator,Channel 1.	1	
	672-0617-00	80009	.	C	I	R	C	U	I	T	B	O	A	R	D	A	S	S	E	M	B	L	E	Y,Attenuator,Channel 2.	1	
-55	211-0097-00	80009	.	S	C	R	E	W,MACHINE,4-40 X 0.312 inch,pnh,steel... (AP)	1																	
-56	2X12161-402	73743	.	N	U	T,PLAIN,HEXAGON,4-40 X 0.188 inch,brass... (AP) (80009 No. 210-0406-00)	2																			
-57	211-0008-00	80009	.	S	C	R	E	W,MACHINE,4-40 X 0.25 inch,pnh,steel.... (AP)	2																	
-58	214-2519-00	80009	.	L	E	V	E	R,SWITCH,AC-ground-DC.....	1																	
-59	2222-801-96138	80031	.	C	A	P	A	C	I	T	O	R,VARIABLE,CERAMIC DIELECTRIC,.... 0.5-3pF,400V (80009 No. 281-0214-00)	1													
-60	441-1364-00	80009	.	C	H	A	S	I	S,ATTENUATOR BOARD.....	1																

AIR FORCE TO33A1-13-496-1
 NAVELEX 0969-LP-170-0010
 Circuit Board Assembly, Vertical Module

FIG. & INDEX NO.	PART NUMBER	FSCM	DESCRIPTION							UNITS PER ASSY	USABLE ON CODE
			1	2	3	4	5	6	7		
8-4-89	131-1758-05	80009	.	.	CONTACT ASSEMBLY, ELECTRICAL, 11 contact....					1	
	131-1758-06	80009	.	.	CONTACT ASSEMBLY, ELECTRICAL, 10 contact....					1	
-90	670-4850-00	80009	.	.	CIRCUIT BOARD ASSEMBLY, Cam Switch, Channel. 1, See Figure 6 for Breakdown					1	
	670-4850-01	80009	.	.	CIRCUIT BOARD ASSEMBLY, Cam Switch, Channel. 2, See Figure 6 for Breakdown					1	
-91	388-CM40915	12697	.	.	RESISTOR, VARIABLE, NONWIRE WOUND, 5K ohm, ... 10%, 0.5W (80009 No. 311-1783-00)					1	
-92	2X20224-402	73743	.	.	NUT, PLAIN, HEXAGON, 0.25-32 X 0.312 inch, ... brass (AP) (80009 No. 210-0583-00)					1	
-93	1214-05-00-0541C	78189	.	.	WASHER, LOCK, internal, 0.26 ID X 0.40 inch.. OD, steel (AP) (80009 No. 210-0046-00)					1	
-94	376-0029-00	80009	.	.	COUPLING, SHAFT, RIGID, 0.128 ID X 0.312 OD.. X 0.5 inch long					1	
-95	213-0075-00	80009	.	.	SETScrew, 4-40 x 0.094 inch, hex socket, .. steel					2	
-96	381CM40934	12697	.	.	RESISTOR, VARIABLE, NONWIRE WOUND, 5K ohm, ... 20%, 1W, DPST Switch (80009 No. 211-1791-00)					1	
-97	2X20224-402	73734	.	.	NUT, PLAIN, HEXAGON, 0.25-32 X 0.312 inch, ... brass (AP) (80009 No. 210-0583-00)					1	
-98	1214-05-00-0541C	78189	.	.	WASHER, LOCK, internal, 0.26 ID X 0.40 inch.. OD, steel (AP) (80009 No. 210-0046-00)					1	
-99	441-1365-00	80009	.	.	CHASSIS, SCOPE, Attenuator.....					1	
	198-2581-00	80009	.	.	WIRE SET, ELECTRICAL, Attenuator.....					1	
-100	47439	22526	.	.	CONTACT, ELECTRICAL, 0.48 inch long, 22-26. AWG wire (80009 No. 131-0707-00)					6	
-101	352-0164-00	80009	.	.	CONNECTOR BODY, PLUG, ELECTRICAL, 6 wire... black					1	
-102	TEK-175-0829-00	83501	.	.	WIRE, ELECTRICAL, 6 wire ribbon, 0.313 foot long (80009 No. 175-0829-00)					AR	
-103	441-1261-03	80009	.	.	CHASSIS, SCOPE, Main, Vertical Module.....					1	
	198-3416-00	80009	.	.	WIRE SET, ELECTRICAL, Vertical Module.....					2	
-104	47439	22526	.	.	CONTACT, ELECTRICAL, 0.48 inch long, 22-26... AWG wire (80009 No. 131-0707-00)					8	
-105	352-0169-00	80009	.	.	CONNECTOR, BODY, PLUG, ELECTRICAL, 2 wire..... black					4	
-106	175-0825-00	80009	.	.	WIRE, ELECTRICAL, 2 wire ribbon, 0.542 foot.. long					AR	

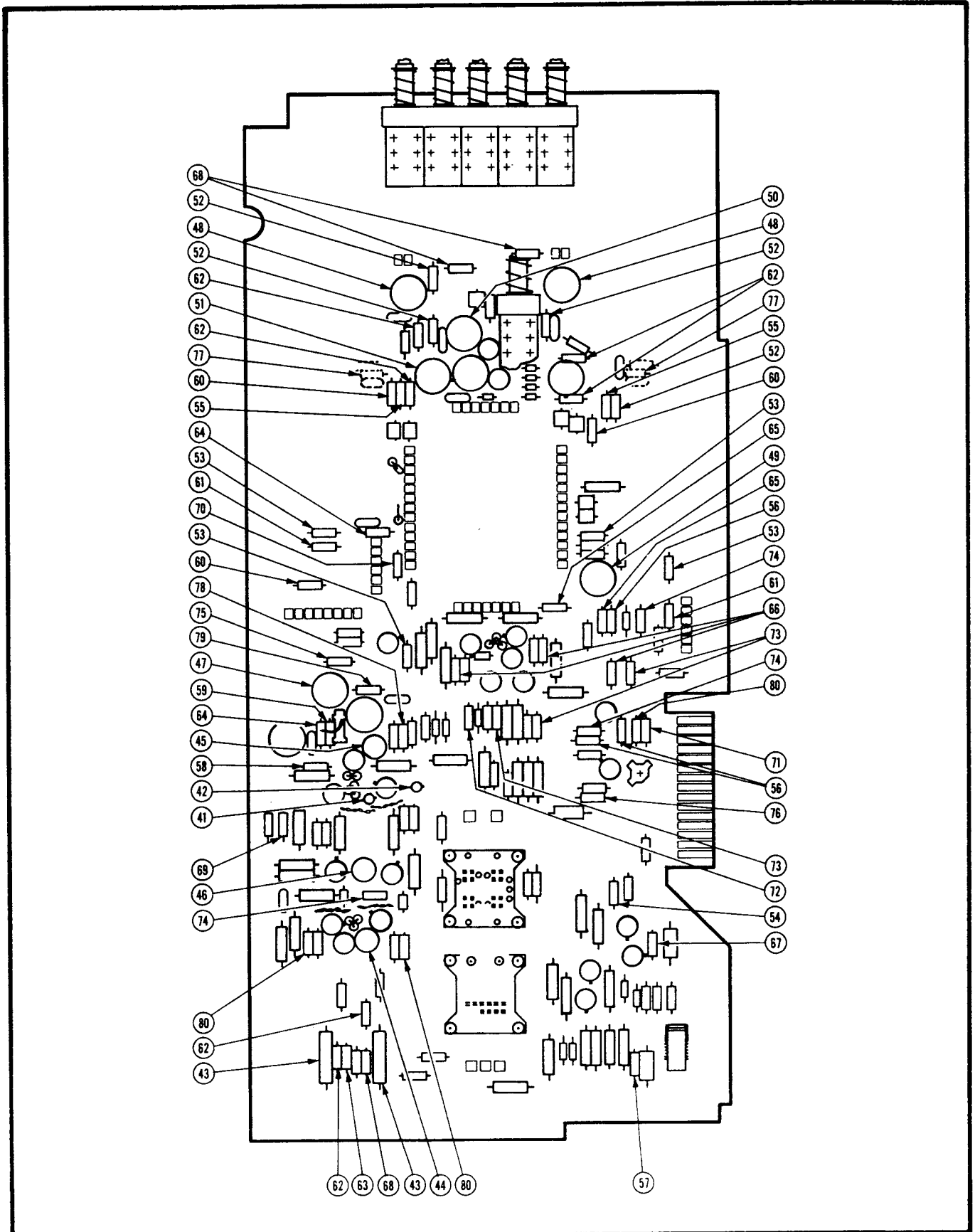

Figure 8-5. Circuit Board Assembly, Vertical (Sheet 2 of 4).

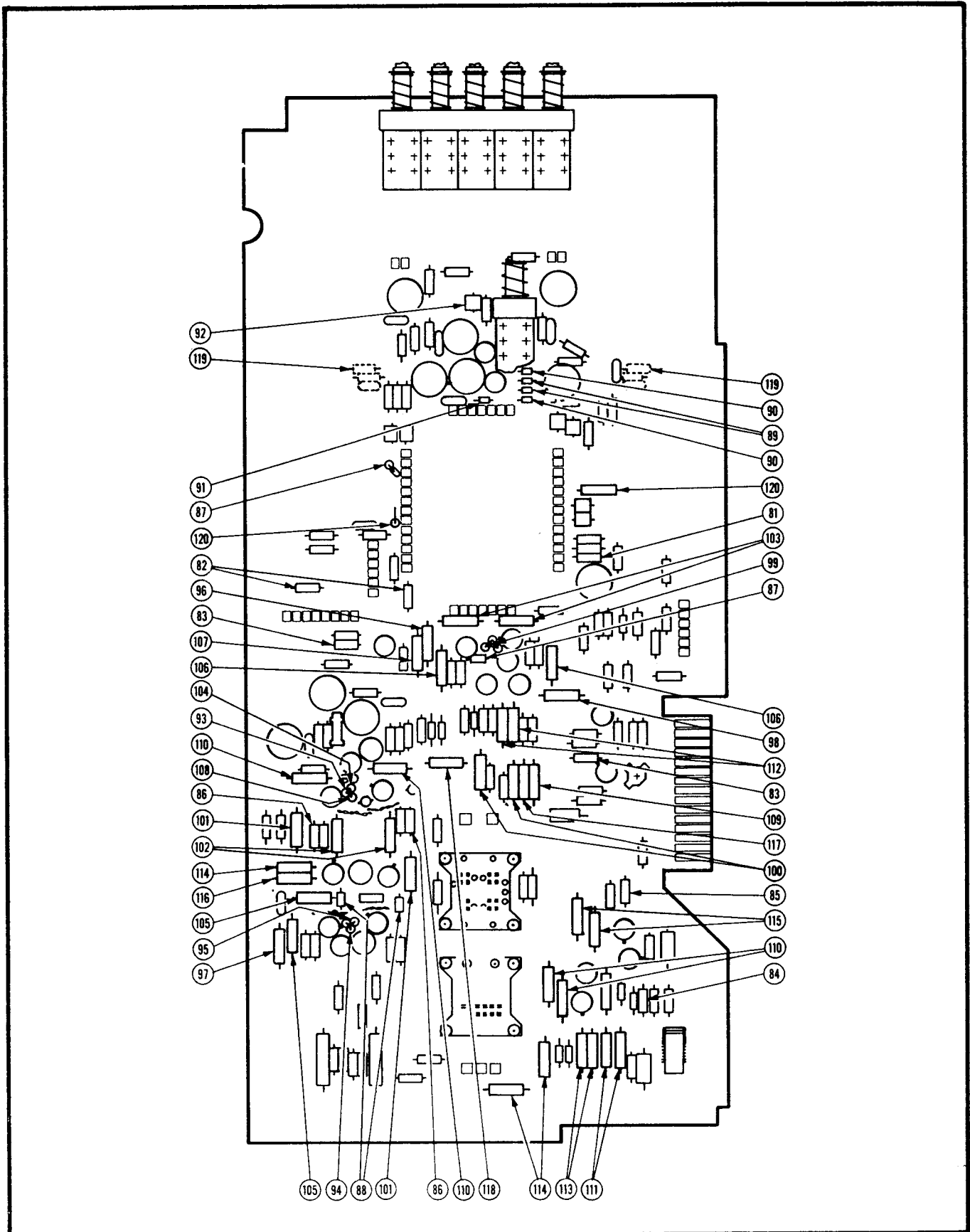

Figure 8-5. Circuit Board Assembly, Vertical (Sheet 3 of 4).

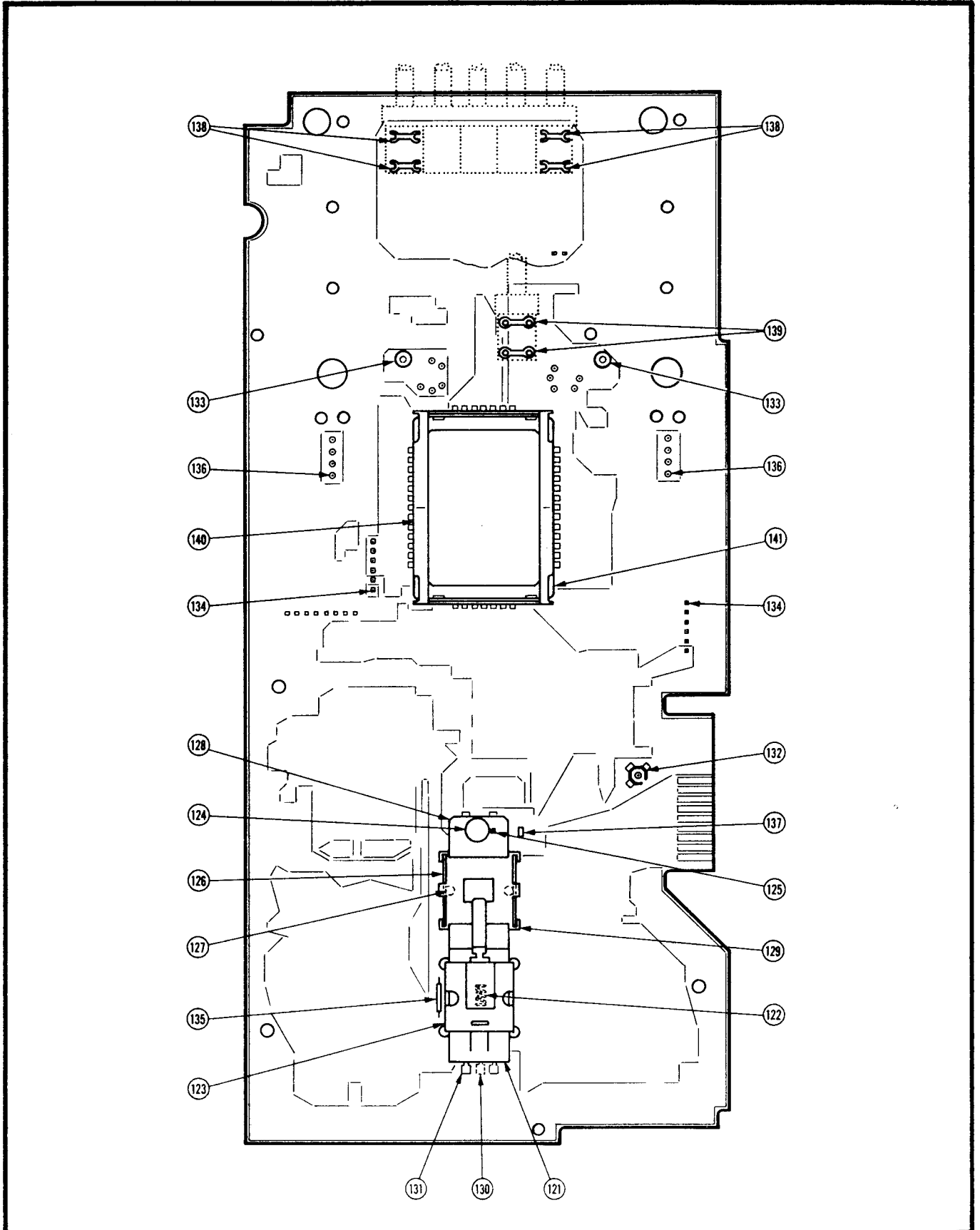

Figure 8-5. Circuit Board Assembly, Vertical (Sheet 4 of 4).

AIR FORCE TO33A1-13-496-1
NAVELEX 0969-LP-170-0010
Circuit Board Assembly, Vertical

FIG. & INDEX NO.	PART NUMBER	FSCM	DESCRIPTION							UNITS PER ASSY	USABLE ON CODE
			1	2	3	4	5	6	7		
8-5-	670-4849-00	80009	CIRCUIT BOARD ASSEMBLY,Vertical,NHA Figure....							REF	
			4-52								
-1	108-0262-00	80009	. COIL,RADIO,FREQUENCY,510NH.....							2	
-2	57-0180-7D-500B	78488	. SHIELDING BEAD,0.6UH (80009 No. 276-0507-00)							6	
-3	108-0570-00	80009	. COIL,RADIO FREQUENCY,fixed,75NH,airwound....							2	
-4	120-1094-00	80009	. TRANSFORMER,RADIO FREQUENCY,68NH,2 turns,...							2	
			27 AWG								
-5	108-0328-00	80009	. COIL,RADIO FREQUENCY,0.3UH.....							2	
-6	120-0384-00	80009	. TRANSFORMER,TOROID,2 turns.....							1	
-7	S6075	07263	. TRANSISTOR,silicon,NPN (80009 No.....							1	
			151-0127-00)								
-8	151-0190-00	80009	. TRANSISTOR,silicon,NPN.....							3	
-9	151-0434-00	80009	. TRANSISTOR,silicon,PNP.....							4	
-10	151-0447-00	80009	. TRANSISTOR,silicon,NPN.....							2	
-11	S039650	07263	. TRANSISTOR,silicon,PNP (80009 No.....							1	
			151-0458-00)								
-12	2N3947	07263	. TRANSISTOR,silicon,NPN (80009 No.....							1	
			151-0460-00)								
-13	151-0472-00	80009	. TRANSISTOR,silicon,NPN.....							5	
-14	SF93007	12040	. TRANSISTOR,silicon,NPN (80009 No.....							2	
			151-0190-02)								
-15	1N4152	07910	. SEMICONDUCTOR DEVICE,silicon,30V,150MA.....							8	
			(80009 No. 152-0141-02)								
-16	CD12676	07910	. SEMICONDUCTOR DEVICE,silicon,400PIV,200MA...							2	
			(80009 No. 152-0246-00)								
-17	152-0269-00	80009	. SEMICONDUCTOR DEVICE,silicon,VVC,33pF,20%,...							2	
			4V								
-18	155-0155-00	80009	. MICROCIRCUIT,LINEAR,vertical preamplifier...							1	
-19	260-1424-01	80009	. SWITCH,PUSH,5 station,2 pole,interlock.....							1	
-20	260-1445-01	80009	. SWITCH,PUSH,1 button.....							1	
-21	281-0205-00	80009	. CAPACITOR,VARIABLE,PLASTIC,5.5-65pF,100V....							2	
-22	513-001 5-30	72982	. CAPACITOR,VARIABLE,CERAMIC DIELECTRIC,.....							4	
			5-35pF,+2.5%,100V (80009 No. 281-0219-00)								
-23	513-001-A-2.0-10	72982	. CAPACITOR,VARIABLE,CERAMIC DIELECTRIC,.....							1	
			2-10pF,100V (80009 No. 281-0221-00)								
-24	308-000C0G0330J	72982	. CAPACITOR,FIXED,CERAMIC DIELECTRIC,33pF,5%,..							1	
			600V (80009 No. 281-0629-00)								
-25	390-049X5P022K	72982	. CAPACITOR,FIXED,CERAMIC DIELECTRIC,22pF,10%,							2	
			100V (80009 No. 281-0759-00)								
-26	8005H9AABZ5U104M	72982	. CAPACITOR,FIXED,CERAMIC DIELECTRIC,0.01UF,..							10	
			20%,50V (80009 No. 281-0775-00)								
-27	390049X5P0680K	72982	. CAPACITOR,FIXED,CERAMIC DIELECTRIC,68pF,10%,							1	
			100V (80009 No. 281-0785-00)								
-28	8005H9AADW5R471K	72982	. CAPACITOR,FIXED,CERAMIC DIELECTRIC,470pF,..							10	
			10%,100V (80009 No. 281-0788-00)								
-29	390049X5P0820K	72982	. CAPACITOR,FIXED,CERAMIC DIELECTRIC,82pF,10%,							1	
			100V (80009 No. 281-0792-00)								
-30	8005-D-COG-150K	72982	. CAPACITOR,FIXED,CERAMIC DIELECTRIC,15pF,10%,							2	
			100V (80009 No. 281-0797-00)								
-31	8005-100-COG-201J	72982	. CAPACITOR,FIXED,CERAMIC DIELECTRIC,200pF,5%,							2	
			100V (80009 No. 281-0809-00)								
-32	8131N300Z5U103P	72982	. CAPACITOR,FIXED,CERAMIC DIELECTRIC,0.01UF,..							2	
			+100-0%,250V (80009 No. 283-0005-00)								

FIG. & INDEX NO.	PART NUMBER	FSCM	DESCRIPTION							UNITS PER ASSY	USABLE ON CODE
			1	2	3	4	5	6	7		
8-5-33	273C20	56289	.	CAPACITOR, FIXED, CERAMIC DIELECTRIC, 0.05UF, ..						1	
-34	8131N145 A 332J	72982	.	CAPACITOR, FIXED, CERAMIC DIELECTRIC, 0.0033UF, 5%, 100V (80009 No. 283-0010-00)						1	
-35	8111A208E102Z	72982	.	CAPACITOR, FIXED, CERAMIC DIELECTRIC, 1000pF, ..						1	
-36	8131N145 E 104Z	72982	.	CAPACITOR, FIXED, CERAMIC DIELECTRIC, 0.1UF, ..						7	
-37	D151E111F0	00853	.	CAPACITOR, FIXED, MICA DIELECTRIC, 110pF, 1%, ..						1	
-38	410P103	56289	.	CAPACITOR, FIXED, PLASTIC, 0.0047UF, 5%, 100V....						1	
-39	162D275X9015CD2	56289	.	CAPACITOR, FIXED, ELECTROLYTIC, 2.7UF, 15V.....						2	
-40	CB47G5	01121	.	RESISTOR, FIXED, COMPOSITION, 4.7 OHM, 5%, 0.25W..						1	
-41	2D1596	50157	.	RESISTOR, THERMAL, 1k ohm, 10% (80009 No.....						1	
-42	1DE104-K-220EC	15454	.	RESISTOR, THERMAL, 100k ohm, 10%, 4MW (80009 No. 307-0181-00)						1	
-43	NS2BB430ROF	91637	.	RESISTOR, FIXED, WIRE WOUND, 430 ohm, 1%, 3W.....						2	
-44	3329P-L58-500	32997	.	RESISTOR, VARIABLE, NONWIRE WOUND, 50 ohm, 10%, ..						1	
-45	3329P-L58-101	32997	.	RESISTOR, VARIABLE, NONWIRE WOUND, 100 ohm, 10%, 0.50W (80009 No. 311-1258-00)						1	
-46	3329P-L58-252	32997	.	RESISTOR, VARIABLE, NONWIRE WOUND, 2.5k ohm, ...						1	
-47	91A-20001M	73138	.	RESISTOR, VARIABLE, NONWIRE WOUND, 20k ohm, 20%, ..						1	
-48	91A-10001M	73138	.	RESISTOR, VARIABLE, NONWIRE WOUND, 10k ohm, 20%, ..						2	
-49	91A-50000M	73138	.	RESISTOR, VARIABLE, NONWIRE WOUND, 5k ohm, 5%, ...						1	
-50	91A-250ROM	73138	.	RESISTOR, VARIABLE, NONWIRE WOUND, 250 ohm,						1	
-51	91A-100ROM	73138	.	RESISTOR, VARIABLE, NONWIRE WOUND, 100 ohm, 20%, ..						1	
-52	CB1005	01121	.	RESISTOR, FIXED, COMPOSITION, 10 ohm, 5%, 0.25W..						4	
-53	CB1015	01121	.	RESISTOR, FIXED, COMPOSITION, 100 ohm, 5%, 0.25W.						4	
-54	CB1025	01121	.	RESISTOR, FIXED, COMPOSITION, 1k ohm, 5%, 0.25W..						1	
-55	CB1035	01121	.	RESISTOR, FIXED, COMPOSITION, 10k ohm, 5%, 0.25W.						2	
-56	CB1215	01121	.	RESISTOR, FIXED, COMPOSITION, 120 ohm, 5%, 0.25W.						3	
-57	CB1315	01121	.	RESISTOR, FIXED, COMPOSITION, 130 ohm, 5%, 0.25W.						1	

AIR FORCE TO33A1-13-496-1
 NAVELEX 0969-LP-170-0010
 Circuit Board Assembly, Vertical

FIG. & INDEX NO.	PART NUMBER	FSCM	DESCRIPTION							UNITS PER ASSY	USABLE ON CODE
			1	2	3	4	5	6	7		
8-5-58	CB1325	01121	.	RESISTOR, FIXED, COMPOSITION, 1.3k ohm, 5%, 0.25W						1	
				(80009 No. 315-0132-00)							
-59	CB1335	01121	.	RESISTOR, FIXED, COMPOSITION, 13k ohm, 5%, 0.25W.						1	
				(80009 No. 315-0133-00)							
-60	CB1515	01121	.	RESISTOR, FIXED, COMPOSITION, 150 ohm, 5%, 0.25W.						3	
				(80009 No. 315-0151-00)							
-61	CB1825	01121	.	RESISTOR, FIXED, COMPOSITION, 1.8k ohm, 5%, 0.25W						2	
				(80009 No. 315-0182-00)							
-62	CB2005	01121	.	RESISTOR, FIXED, COMPOSITION, 20 ohm, 5%, 0.25W..						6	
				(80009 No. 315-0200-00)							
-63	CB2015	01121	.	RESISTOR, FIXED, COMPOSITION, 200 ohm, 5%, 0.25W.						1	
				(80009 No. 315-0201-00)							
-64	CB2025	01121	.	RESISTOR, FIXED, COMPOSITION, 2k ohm, 5%, 0.25W..						2	
				(80009 No. 315-0202-00)							
-65	CB2405	01121	.	RESISTOR, FIXED, COMPOSITION, 24 ohm, 5%, 0.25W..						2	
				(80009 No. 315-0240-00)							
-66	CB2415	01121	.	RESISTOR, FIXED, COMPOSITION, 240 ohm, 5%, 0.25W.						3	
				(80009 No. 315-0241-00)							
-67	CB2235	01121	.	RESISTOR, FIXED, COMPOSITION, 22k ohm, 5%, 0.25W.						1	
				(80009 No. 315-0223-00)							
-68	CB3015	01121	.	RESISTOR, FIXED, COMPOSITION, 300 ohm, 5%, 0.25W.						3	
				(80009 No. 315-0301-00)							
-69	CB3305	01121	.	RESISTOR, FIXED, COMPOSITION, 33 ohm, 5%, 0.25W..						1	
				(80009 No. 315-0330-00)							
-70	CB3325	01121	.	RESISTOR, FIXED, COMPOSITION, 3.3k ohm, 5%, 0.25W						1	
				(80009 No. 315-0332-00)							
-71	CB3615	01121	.	RESISTOR, FIXED, COMPOSITION, 360 ohm, 5%, 0.25W.						1	
				(80009 No. 315-0361-00)							
-72	CB3625	01121	.	RESISTOR, FIXED, COMPOSITION, 3.6k ohm, 5%, 0.25W						1	
				(80009 No. 315-0362-00)							
-73	CB4305	01121	.	RESISTOR, FIXED, COMPOSITION, 43 ohm, 5%, 0.25W..						3	
				(80009 No. 315-0430-00)							
-74	CB4315	01121	.	RESISTOR, FIXED, COMPOSITION, 430 ohm, 5%, 0.25W.						3	
				(80009 No. 315-0431-00)							
-75	CB4705	01121	.	RESISTOR, FIXED, COMPOSITION, 47 ohm, 5%, 0.25W..						1	
				(80009 No. 315-0470-00)							
-76	CB4715	01121	.	RESISTOR, FIXED, COMPOSITION, 470 ohm, 5%, 0.25W.						1	
				(80009 No. 315-0471-00)							
-77	CB4745	01121	.	RESISTOR, FIXED, COMPOSITION, 470k ohm, 5%, 0.25W						2	
				(80009 No. 315-0474-00)							
-78	CB5115	01121	.	RESISTOR, FIXED, COMPOSITION, 510 ohm, 5%, 0.25W.						1	
				(80009 No. 315-0511-00)							
-79	CB5125	01121	.	RESISTOR, FIXED, COMPOSITION, 5.1k ohm, 5%, 0.25W						1	
				(80009 No. 315-0512-00)							
-80	CB5605	01121	.	RESISTOR, FIXED, COMPOSITION, 56 ohm, 5%, 0.25W..						3	
				(80009 No. 315-0560-00)							
-81	CB5625	01121	.	RESISTOR, FIXED, COMPOSITION, 5.6k ohm, 5%, 0.25W						1	
				(80009 No. 315-0562-00)							
-82	CB6205	01121	.	RESISTOR, FIXED, COMPOSITION, 62 ohm, 5%, 0.25W..						2	
				(80009 No. 315-0620-00)							

FIG. & INDEX NO.	PART NUMBER	FSCM	DESCRIPTION							UNITS PER ASSY	USABLE ON CODE
			1	2	3	4	5	6	7		
8-5-83	CB6215	01121	.	RESISTOR, FIXED, COMPOSITION, 620 ohm, 5%, 0.25W..						2	
				(80009 No. 315-0621-00)							
-84	CB6235	01121	.	RESISTOR, FIXED, COMPOSITION, 62k ohm, 5%, 0.25W..						1	
				(80009 No. 315-0623-00)							
-85	CB6815	01121	.	RESISTOR, FIXED, COMPOSITION, 680 ohm, 5%, 0.25W..						1	
				(80009 No. 315-0681-00)							
-86	CB8205	01121	.	RESISTOR, FIXED, COMPOSITION, 82 ohm, 5%, 0.25W...						2	
				(80009 No. 315-0820-00)							
-87	BB1005	01121	.	RESISTOR, FIXED, COMPOSITION, 10 ohm, 5%, 0.125W..						2	
				(80009 No. 317-0100-00)							
-88	BB1215	01121	.	RESISTOR, FIXED, COMPOSITION, 120 ohm, 5%, 0.125W.						2	
				(80009 No. 317-0121-00)							
-89	BB1225	01121	.	RESISTOR, FIXED, COMPOSITION, 1.2k ohm, 5%, 0.125W						2	
				(80009 No. 317-0122-00)							
-90	BB2025	01121	.	RESISTOR, FIXED, COMPOSITION, 2k ohm, 5%, 0.125W..						2	
				(80009 No. 317-0202-00)							
-91	BB4715	01121	.	RESISTOR, FIXED, COMPOSITION, 470 ohm, 5%, 0.125W.						1	
				(80009 No. 317-0471-00)							
-92	BB5625	01121	.	RESISTOR, FIXED, COMPOSITION, 5.6k ohm, 5%, 0.125W						1	
				(80009 No. 317-0562-00)							
-93	MFF1816G10R20F	91637	.	RESISTOR, FIXED, FILM, 10.2 ohm, 1%, 0.125W.....						1	
				(80009 No. 321-0002-00)							
-94	MFF1816G12R70F	91637	.	RESISTOR, FIXED, FILM, 12.7 ohm, 1%, 0.125W.....						1	
				(80009 No. 321-0011-00)							
-95	MFF1816G30R10F	91637	.	RESISTOR, FIXED, FILM, 30.1 ohm, 1%, 0.125W.....						2	
				(80009 No. 321-0047-00)							
-96	MFF1816G38R30F	91637	.	RESISTOR, FIXED, FILM, 38.3 ohm, 1%, 0.125W.....						1	
				(80009 No. 321-0057-00)							
-97	MFF1816G39R20F	91637	.	RESISTOR, FIXED, FILM, 39.2 ohm, 1%, 0.125W.....						1	
				(80009 No. 321-0058-00)							
-98	MFF1816G41R20F	91637	.	RESISTOR, FIXED, FILM, 41.2 ohm, 1%, 0.125W.....						1	
				(80009 No. 321-0060-00)							
-99	MFF1816G49R90F	91637	.	RESISTOR, FIXED, FILM, 49.9 ohm, 1%, 0.125W.....						3	
				(80009 No. 321-0068-00)							
-100	MFF1816G60R40F	91637	.	RESISTOR, FIXED, FILM, 60.4 ohm, 1%, 0.125W.....						2	
				(80009 No. 321-0076-00)							
-101	MFF1816G66R50F	91637	.	RESISTOR, FIXED, FILM, 66.5 ohm, 1%, 0.125W.....						2	
				(80009 No. 321-0080-00)							
-102	MFF1816G75R00F	91637	.	RESISTOR, FIXED, FILM, 75 ohm, 1%, 0.125W.....						2	
				(80009 No. 321-0085-00)							
-103	MFF1816G80R60F	91637	.	RESISTOR, FIXED, FILM, 80.6 ohm, 1%, 0.125W.....						2	
				(80009 No. 321-0088-00)							
-104	MFF1816G93R10F	91637	.	RESISTOR, FIXED, FILM, 93.1 ohm, 1%, 0.125W.....						1	
				(80009 No. 321-0094-00)							
-105	MFF1816G110ROF	91637	.	RESISTOR, FIXED, FILM, 110 ohm, 1%, 0.125W.....						2	
				(80009 No. 321-0101-00)							
-106	MFF1816G133ROF	91637	.	RESISTOR, FIXED, FILM, 133 ohm, 1%, 0.125W.....						2	
				(80009 No. 321-0109-00)							
-107	MFF1816G150ROF	91637	.	RESISTOR, FIXED, FILM, 150 ohm, 1%, 0.125W.....						1	
				(80009 No. 321-0114-00)							

AIR FORCE TO33A1-13-496-1
NAVELEX 0969-LP-170-0010
Circuit Board Assembly, Vertical

FIG. & INDEX NO.	PART NUMBER	FSCM								UNITS PER ASSY	USABLE ON CODE	
			1	2	3	4	5	6	7			DESCRIPTION
8-5-108	MFF1816G130ROF	91637	1	
-109	MFF1816G174ROF	91637	1	
-110	MFF1816G287ROF	91637	4	
-111	MFF1816G294ROF	91637	2	
-112	MFF1816G324ROF	91637	2	
-113	MFF1816G332ROF	91637	2	
-114	MFF1816G392ROF	91637	3	
-115	MFF1816G412ROF	91637	2	
-116	MFF1816G511ROF	91637	1	
-117	MFF1816G11000F	91637	1	
-118	MFF1816G35702F	91637	1	
-119	MFF1816G10003F	91637	2	
-120	MFF1816D400ROC	91637	2	
	105-0421-00	80009	1	
-121	105-0420-00	80009	1	
-122	214-1779-00	80009	1	
-123	351-0359-00	80009	1	
	105-0423-00	80009	1	
-124	376-0146-00	80009	1	
-125	213-0048-00	80009	1	
-126	214-1126-01	80009	2	
-127	214-1127-00	80009	2	
-128	105-0422-00	80009	1	
-129	351-0355-00	80009	1	
-130	131-1030-00	80009	6	
-131	131-1031-00	80009	7	
-132	131-1003-00	80009	1	
-133	FTSM19L1	98291	2	
-134	47357	22526	25	
	47350	22526	2	
-135	131-0566-00	80009	1	

FIG. & INDEX NO.	PART NUMBER	FSCM	DESCRIPTION							UNITS PER ASSY	USABLE ON CODE
			1	2	3	4	5	6	7		
8-5-136	75060	22526	19	
				
-137	214-0579-00	80009	1	
-138	J-64281	71590	4	
				
-139	361-0383-00	80009	2	
				
-140	343-0519-00	80009	1	
-141	380-0421-00	80009	1	

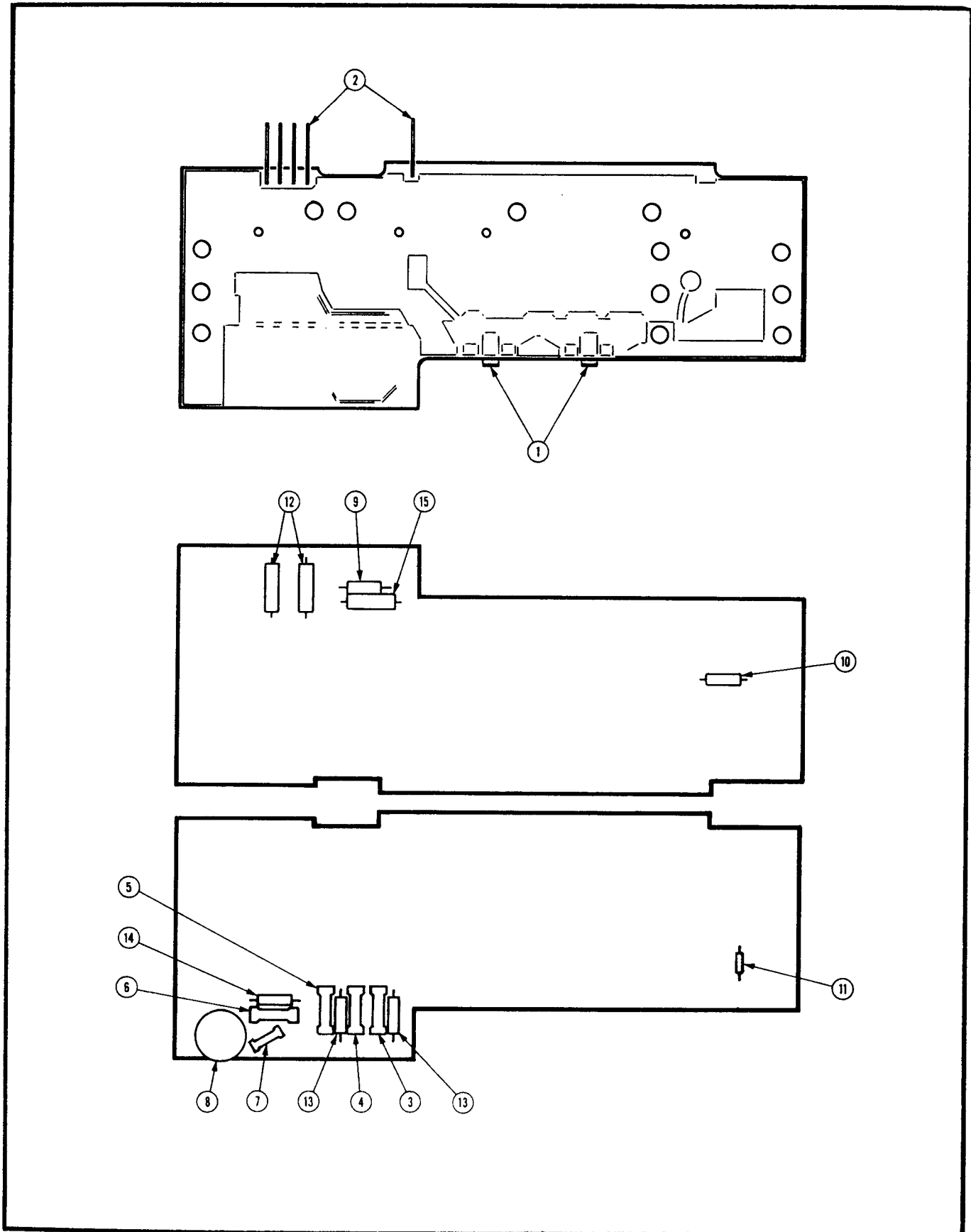

Figure 8-6. Circuit Board Assembly, Cam Switch, Channel 1 (Sheet 1 of 2).

FIG. & INDEX NO.	PART NUMBER	FSCM	DESCRIPTION							UNITS PER ASSY	USABLE ON CODE
			1	2	3	4	5	6	7		
8-6-	670-4850-00	80009	CIRCUIT BOARD ASSEMBLY, Cam Switch, Channel 1, .. NHA Figure 4-90							REF	
-1	131-1978-00	80009	. CONTACT, ELECTRICAL, circuit board to shield..							2	
-2	131-1979-00	80009	. CONTACT, ELECTRICAL, male, 0.415 inch long.....							5	
-3	301-050COG0180J	72982	. CAPACITOR, FIXED, CERAMIC DIELECTRIC, 18pF, 5%, .. 500V (80009 No. 281-0578-00)							1	
-4	301-050COG0210J	72982	. CAPACITOR, FIXED, CERAMIC DIELECTRIC, 21pF, 5%, .. 500V (80009 No. 281-0579-00)							1	
-5	301-000C0J0399C	72982	. CAPACITOR, FIXED, CERAMIC DIELECTRIC, 3.9pF, ... 10%, 500V (80009 No. 281-0593-00)							1	
-6	301-000C0J0229C	72982	. CAPACITOR, FIXED, CERAMIC DIELECTRIC, 2.2pF, ... +/-0.25pF, 500V (80009 No. 281-0604-00)							1	
-7	374-005COG909B	72982	. CAPACITOR, FIXED, CERAMIC DIELECTRIC, 9pF, +/-0.1pF, 500V (80009 No. 281-0789-00)							1	
-8	91A-200ROM	73138	. RESISTOR, VARIABLE, NONWIRE WOUND, 200 ohm, 20%, 0.50W (80009 No. 311-1566-00)							1	
-9	CB1315	01121	. RESISTOR, FIXED, COMPOSITION, 130 ohm, 5%, 0.25W. (80009 No. 315-0131-00)							1	
-10	CB5105	01121	. RESISTOR, FIXED, COMPOSITION, 51 ohm, 5%, 0.25W.. (80009 No. 315-0510-00)							1	
-11	BB1055	01121	. RESISTOR, FIXED, COMPOSITION, 1M ohm, 5%, 0.125W. (80009 No. 317-0105-00)							1	
-12	MFF1816G150ROD	91637	. RESISTOR, FIXED, FILM, 150 ohm, 0.5%, 0.125W..... (80009 No. 321-0114-01)							2	
-13	MFF1816G200ROD	91637	. RESISTOR, FIXED, FILM, 200 ohm, 0.5%, 0.125W..... (80009 No. 321-0126-01)							2	
-14	MFF1816G133R3D	91637	. RESISTOR, FIXED, FILM, 133.3 ohm, 0.5%, 0.125W... (80009 No. 321-1708-01)							1	
-15	MFF1816G800ROD	91637	. RESISTOR, FIXED, FILM, 800 ohm, 0.5%, 0.125W..... (80009 No. 321-1709-01)							1	

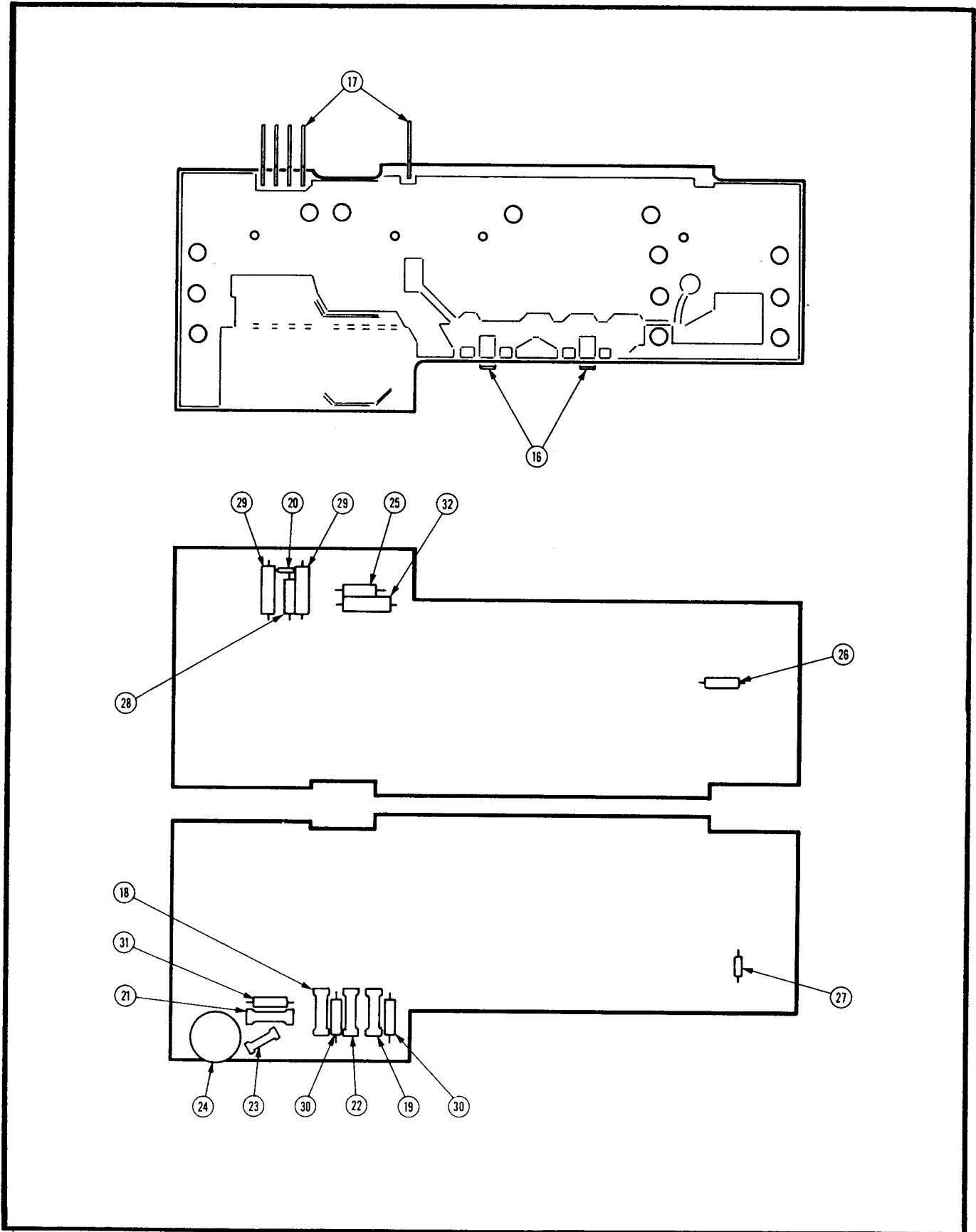

Figure 8-6. Circuit Board Assembly, Cam Switch, Channel 2 (Sheet 2 of 2).

FIG. & INDEX NO.	PART NUMBER	FSCM	DESCRIPTION							UNITS PER ASSY	USABLE ON CODE
			1	2	3	4	5	6	7		
8-6-	670-4850-01	80009	CIRCUIT BOARD ASSEMBLY, Cam Switch, Channel 2, ... NHA Figure 4-90							REF	
-16	131-1978-00	80009	. CONTACT, ELECTRICAL, circuit board to shield..							2	
-17	131-1979-00	80009	. CONTACT, ELECTRICAL, male, 0.415 inch long.....							5	
-18	301-000C0K0189B	72982	. CAPACITOR, FIXED, CERAMIC DIELECTRIC, 1.8pF, ... 10%, 500V (80009 No. 281-0557-00)							1	
-19	301-000C0G0240J	72982	. CAPACITOR, FIXED, CERAMIC DIELECTRIC, 24pF, 5%, .. 500V (80009 No. 281-0564-00)							1	
-20	8111B061C0G220J	72982	. CAPACITOR, FIXED, CERAMIC DIELECTRIC, 22pF, 5%, .. 50V (80009 No. 283-0154-00)							1	
-21	301-000C0J0279C	72982	. CAPACITOR, FIXED, CERAMIC DIELECTRIC, 2.7pF, ... 10%, 500V (80009 No. 281-0547-00)							1	
-22	301-000C0H0759D	72982	. CAPACITOR, FIXED, CERAMIC DIELECTRIC, 7.5pF, ... 500V (80009 No. 281-0601-00)							1	
-23	374-005C0G909B	72982	. CAPACITOR, FIXED, CERAMIC DIELECTRIC, 9pF, +/-0.1pF, 500V (80009 No. 281-0789-00)							1	
-24	91A-200ROM	73138	. RESISTOR, VARIABLE, NONWIRE WOUND, 200 ohm, 20%, 0.50W (80009 No. 311-1566-00)							1	
-25	CB1215	01121	. RESISTOR, FIXED, COMPOSITION, 120 ohm, 5%, 0.25W. (80009 No. 315-0121-00)							1	
-26	CB5105	01121	. RESISTOR, FIXED, COMPOSITION, 51 ohm, 5%, 0.25W.. (80009 No. 315-0510-00)							1	
-27	BB1055	01121	. RESISTOR, FIXED, COMPOSITION, 1M ohm, 5%, 0.125W. (80009 No. 317-0105-00)							1	
-28	BB3005	01121	. RESISTOR, FIXED, COMPOSITION, 30 ohm, 5%, 0.125W. (80009 No. 317-0300-00)							1	
-29	MFF1816G150ROD	91637	. RESISTOR, FIXED, FILM, 150 ohm, 0.5%, 0.125W..... (80009 No. 321-0114-01)							2	
-30	MFF1816G200ROD	91637	. RESISTOR, FIXED, FILM, 200 ohm, 0.5%, 0.125W..... (80009 No. 321-0126-01)							2	
-31	MFF1816G133R3D	91637	. RESISTOR, FIXED, FILM, 133.3 ohm, 0.5%, 0.125W... (80009 No. 321-1708-01)							1	
-32	MFF1816G800ROD	91637	. RESISTOR, FIXED, FILM, 800 ohm, 0.5%, 0.125W..... (80009 No. 321-1709-01)							1	

AIR FORCE TO33A1-13-496-1
NAVELEX 0969-LP-170-0010
Circuit Board Assembly, Horizontal Module

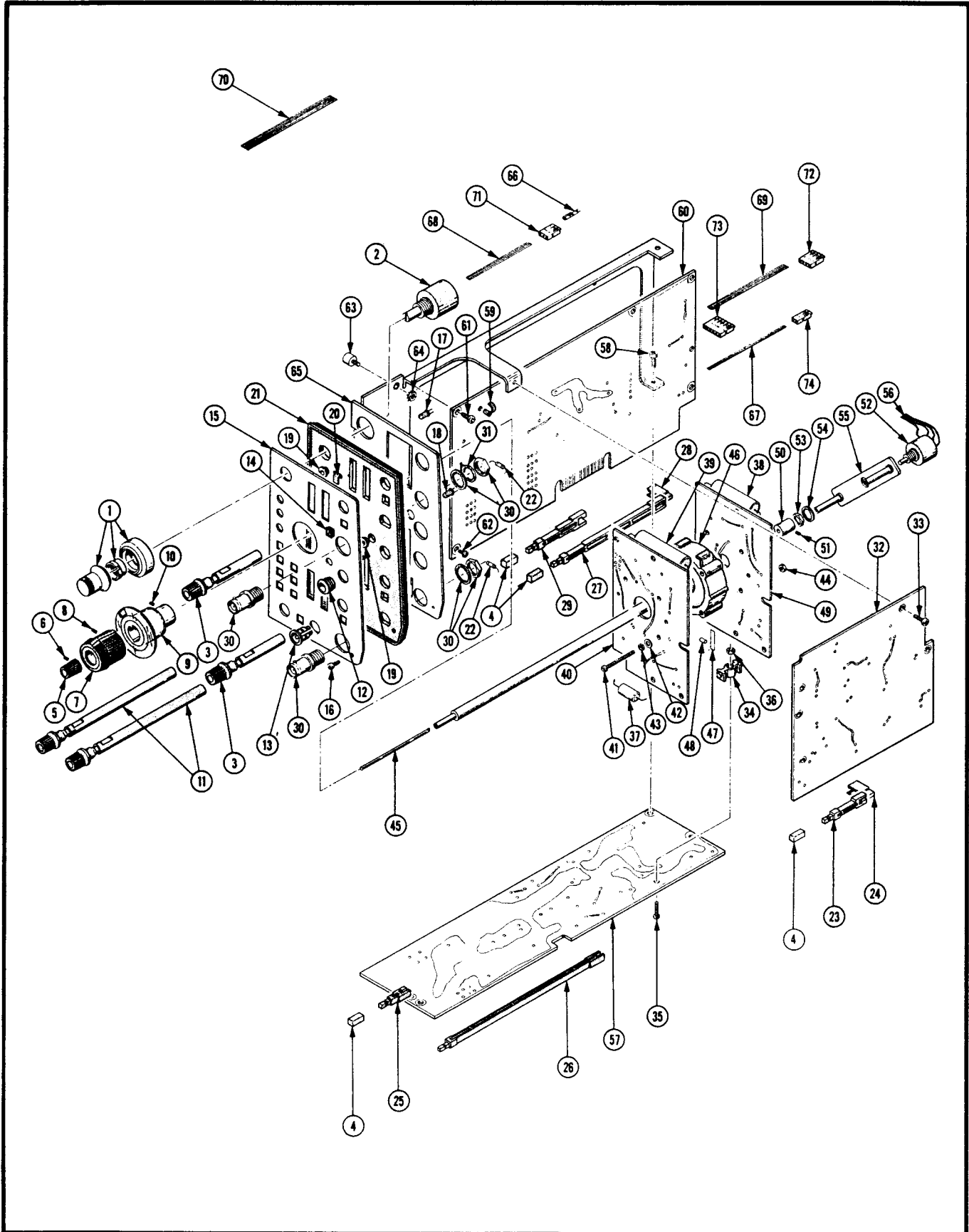

Figure 8-7. Circuit Board Assembly, Horizontal Module.

FIG. & INDEX NO.	PART NUMBER	FSCM	DESCRIPTION							UNITS PER ASSY	USABLE ON CODE
			1	2	3	4	5	6	7		
8-7-	672-0613-00	80009	CIRCUIT BOARD ASSEMBLY,Horizontal Module.....							REF	
-1	461-S-70	05129	. DIAL,CONTROL,10 turn for 0.25 inch diameter. shaft (80009 No. 331-0328-00)							1	
-2	3540S-561-103	32997	. RESISTOR,VARIABLE,WIREWOUND,10k ohm,5%,2W... (80009 No. 311-1729-00)							1	
-3	384-1366-00	80009	. EXTENSION SHAFT,0.2 OD X 2.135 inch long,... with knob							2	
-4	366-1559-00	80009	. PUSH BUTTON,gray.....							10	
-5	366-1346-02	80009	. KNOB,red,variable.....							1	
-6	213-0153-00	80009	. . SETSCREW,5-40 X 0.125 inch,hex socket,.... steel							1	
-7	366-1219-00	80009	. KNOB,0.906 OD X 0.89 inch long,Time/Division							1	
-8	213-0243-00	80009	. . SETSCREW,5-40 X 0.25 inch,hex socket,steel							2	
-9	354-0442-01	80009	. RING,KNOB SKIRT.....							1	
-10	213-0004-00	80009	. . SETSCREW,6-32 X 0.188 inch,hex socket,.... steel							1	
-11	384-1350-02	80009	. KNOB,0.28 OD X 4.515 inch long.....							2	
-12	358-0569-00	80009	. BUSHING,PLASTIC,0.412 OD X 0.257 ID X 0.293. inch long							1	
-13	358-0550-00	80009	. BUSHING,SHAFT,0.15 ID X 0.3 inch OD,plastic.							4	
-14	426-1072-00	80009	. FRAME,PUSH BUTTON,plastic.....							10	
-15	333-2278-00	80009	. PANEL,FRONT,Horizontal.....							1	
-16	213-0113-00	80009	. SCREW,TAPPING,THREAD FORMING,2-32 X 0.312... inch,phn,steel (AP)							1	
-17	150-1001-02	28480	. LAMP,LIGHT EMITTING DIODE,red,2V,100MA..... (80009 No. 150-1001-00)							3	
-18	OSL-16L-100	50437	. LAMP,LIGHT EMITTING DIODE,green,55MA.....							1	
-19	352-0477-00	80009	. HOLDER,LIGHT EMITTING DIODE.....							4	
-20	214-2329-00	80009	. SPRING,GROUND,front panel.....							1	
-21	342-0367-00	80009	. INSULATOR,PLATE,front panel,horizontal.....							1	
-22	CB2705	01121	. RESISTOR,FIXED,COMPOSITION,27 ohm,5%,0.25W.. (80009 No. 315-0270-00)							2	
	384-1389-01	80009	. EXTENSION SHAFT,1.905 inch long,offset,.... plastic							1	
-23	384-1099-00	80009	. . EXTENSION SHAFT,push button,1.54 inch long							1	
-24	103-0186-02	80009	. . ADAPTER,EXTENSION SHAFT,push button,0.60.. offset							1	
-25	384-1136-00	80009	. EXTENSION SHAFT,0.95 inch long.....							1	
-26	384-1129-00	80009	. EXTENSION SHAFT,5.607 inch long.....							1	
	384-1390-00	80009	. EXTENSION SHAFT,4.460 inch long,offset.....							3	
-27	384-1101-00	80009	. . EXTENSION SHAFT,push button,4.14 inch long							3	
-28	103-0186-01	80009	. . ADAPTER,EXTENSION SHAFT,push button,0.45.. offset							3	
-29	384-1341-00	80009	. EXTENSION SHAFT,2.183 inch long,offset.....							4	
-30	28JRI66-1	24931	. CONNECTOR,RECEPTACLE,BNC female (80009 No... 131-0352-02)							2	
-31	210-0255-00	80009	. TERMINAL,LUG,0.391 inch ID,internal tooth...							1	
-32	670-4847-00	80009	. CIRCUIT BOARD ASSEMBLY,Trigger,See Figure 8. for Breakdown							1	

AIR FORCE TO33A1-13-496-1
 NAVELEX 0969-LP-170-0010
 Circuit Board Assembly, Horizontal Module

FIG. & INDEX NO.	PART NUMBER	FSCM	DESCRIPTION							UNITS PER ASSY	USABLE ON CODE
			1	2	3	4	5	6	7		
8-7-33	213-0146-00	80009	.	SCREW,TAPPING,THREAD FORMING,6-20 X 0.313...						1	
				inch,pnh,steel (AP)							
-34	343-0582-00	80009	.	RETAINER,SWITCH,black plastic.....						2	
-35	211-0012-00	80009	.	SCREW,MACHINE,4-40 X 0.375 inch,pnh,steel...						1	
				(AP)							
	211-0097-00	80009	.	SCREW,MACHINE,4-40 X 0.312 inch,pnh,steel...						1	
				(AP)							
-36	2X12161-402	73743	.	NUT,PLAIN,HEXAGON,4-40 X 0.188 inch,brass...						2	
				(80009 No. 210-0406-00)							
	672-0614-00	80009	.	CIRCUIT BOARD ASSEMBLY,Time/Division Switch.						1	
	295-0177-00	80009	.	CAPACITOR SET,MATCHED,0.01uF,1uF,10uF,....						1	
				0.01uF							
-37	285-0753-00*	80009	.	CAPACITOR,FIXED,PLASTIC,0.01uF,3.5%,100V						2	
-38	285-0782-00*	80009	.	CAPACITOR,FIXED,PLASTIC,1.0uF,3.5%,100V.						2	
-39	285-1060-01*	80009	.	CAPACITOR,FIXED,PLASTIC,10uF,3%,25V.....						1	
-40	670-4848-00	80009	.	CIRCUIT BOARD ASSEMBLY,A Timing,See Figure						1	
				9 for Breakdown							
-41	211-0019-00	80009	.	SCREW,MACHINE,4-40 X 1.0 inch,pnh,steel...						4	
				(AP)							
-42	210-0994-00	80009	.	WASHER,FLAT,0.125 ID X 0.25 inch OD,steel.						4	
				(AP)							
-43	210-0054-00	80009	.	WASHER,LOCK,split,0.118 ID X 0.212 inch...						4	
				OD,steel (AP)							
-44	2X12161-402	73743	.	NUT,PLAIN,HEXAGON,4-40 X 0.188 inch,brass.						2	
				(AP) (80009 No. 210-0406-00)							
-45	384-1322-00	80009	.	EXTENSION SHAFT,0.081 OD X 11.05 inch long						1	
-46	263-1110-00	80009	.	ACTUATOR ASSEMBLY,ROTARY,Timing Switch....						1	
-47	214-1139-02	80009	.	SPRING,FLAT,gold colored.....						4	
-48	401-0322-00	80009	.	ROLLER,DETENT,0.219 OD X 0.165 inch long						4	
-49	670-3551-02	80009	.	CIRCUIT BOARD ASSEMBLY,B Timing,See Figure						1	
				9 for Breakdown							
-50	376-0141-00	80009	.	COUPLING,SHAFT,RIGID,for 0.08 to 0.125...						1	
				inch diameter shaft							
-51	213-0075-00	80009	.	SETSCREW,4-40 X 0.094 inch,hex socket,..						3	
				steel							
-52	381CM40935	12697	.	RESISTOR,VARIABLE,NONWIRE WOUND,20k ohm,..						1	
				1W,DPST switch (80009 No. 311-1793-00)							
-53	2X20224-402	73743	.	NUT,PLAIN,HEXAGON,0.25-32 X 0.312 inch,...						1	
				brass (AP) (80009 No. 210-0583-00)							
-54	1214-05-00-0541C	78189	.	WASHER,LOCK,internal,0.26 ID X 0.40 inch..						1	
				OD,steel (AP) (80009 No. 210-0046-00)							
-55	386-3156-00	80009	.	PLATE,MOUNTING,VARIABLE RESISTOR,2.10 X...						1	
				0.625 X 0.063 inch							
	198-3068-00	80009	.	WIRE SET,ELECTRICAL,timing switch assembly						1	
-56	TEK-175-0828-00	23499	.	WIRE,ELECTRICAL,5 wire ribbon,0.396 feet						AR	
				long (80009 No. 175-0828-00)							
-57	670-4855-00	80009	.	CIRCUIT BOARD ASSEMBLY,Horizontal,See Figure						1	
				10 for Breakdown							
-58	213-0146-00	80009	.	SCREW,TAPPING,THREAD FORMING,6-20 X 0.313...						2	
				inch,pnh,steel (AP)							

*Matched set, must be stocked under NHA.

AIR FORCE TO33A1-13-496-1
 NAVELEX 0969-LP-170-0010
 Circuit Board Assembly, Horizontal Module

FIG. & INDEX NO.	PART NUMBER	FSCM	DESCRIPTION							UNITS PER ASSY	USABLE ON CODE
			1	2	3	4	5	6	7		
8-7-59	343-0088-00	80009	.	CLAMP,LOOP,0.062 inch diameter.....						1	
-60	670-4846-00	80009	.	CIRCUIT BOARD ASSEMBLY,Sweep,See Figure 11..						1	
-61	213-0146-00	80009	.	SCREW,TAPPING,THREAD FORMING,6-20 X 0.313...						4	
-62	213-0138-00	80009	.	SCREW,TAPPING,THREAD FORMING,4-40 X 0.188...						1	
-63	129-0575-00	80009	.	SPACER,POST,0.312 OD X 0.312 inch long,with.						1	
-64	210-0457-00	80009	.	NUT,PLAIN,EXTENDED WASHER,6-32 X 0.312 inch,						1	
-65	441-1366-00	80009	.	CHASSIS,SCOPE,Horizontal.....						1	
-66	198-3417-00	80009	.	WIRE SET,ELECTRICAL,Horizontal Module.....						1	
-66	47439	22526	.	CONTACT,ELECTRICAL,0.48 inch long,22-26...						30	
-67	175-0825-00	80009	.	WIRE,ELECTRICAL,2 wire ribbon,0.271 feet..						AR	
-68	175-0826-00	80009	.	WIRE,ELECTRICAL,3 wire ribbon,0.854 feet..						AR	
-69	TEK-175-0827-00	08261	.	WIRE,ELECTRICAL,4 wire ribbon,0.271 feet..						AR	
-70	TEK-175-0829-00	83501	.	WIRE,ELECTRICAL,6 wire ribbon,0.271 feet..						AR	
-71	352-0161-00	80009	.	CONNECTOR BODY,PLUG,ELECTRICAL,3 wire....						1	
-72	352-0162-00	80009	.	CONNECTOR BODY,PLUG,ELECTRICAL,4 wire....						1	
-73	352-0164-00	80009	.	CONNECTOR BODY,PLUG,ELECTRICAL,6 wire....						3	
-74	352-0169-00	80009	.	CONNECTOR BODY,PLUG,ELECTRICAL,2 wire....						3	

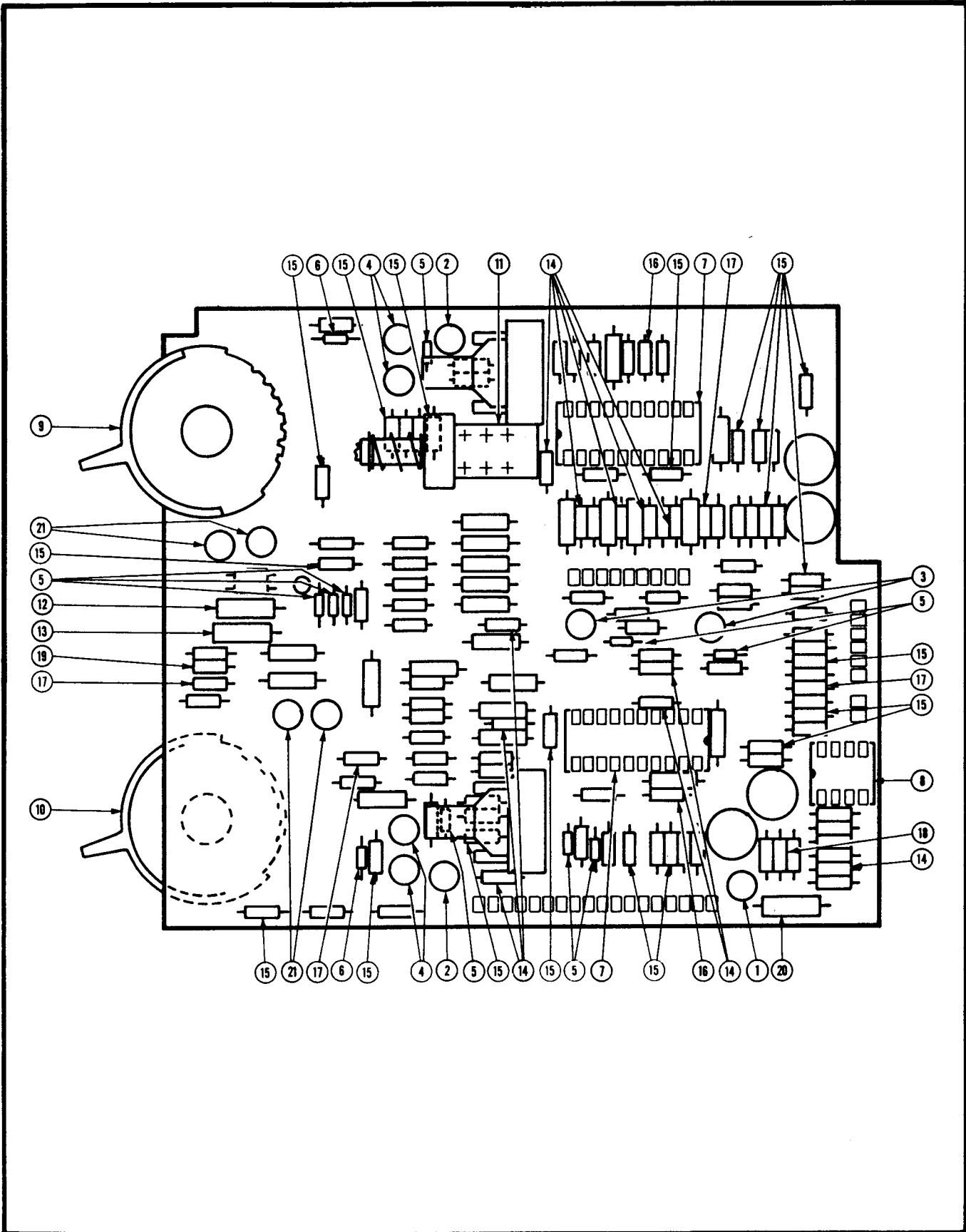

Figure 8-8. Circuit Board Assembly, Trigger (Sheet 1 of 3).

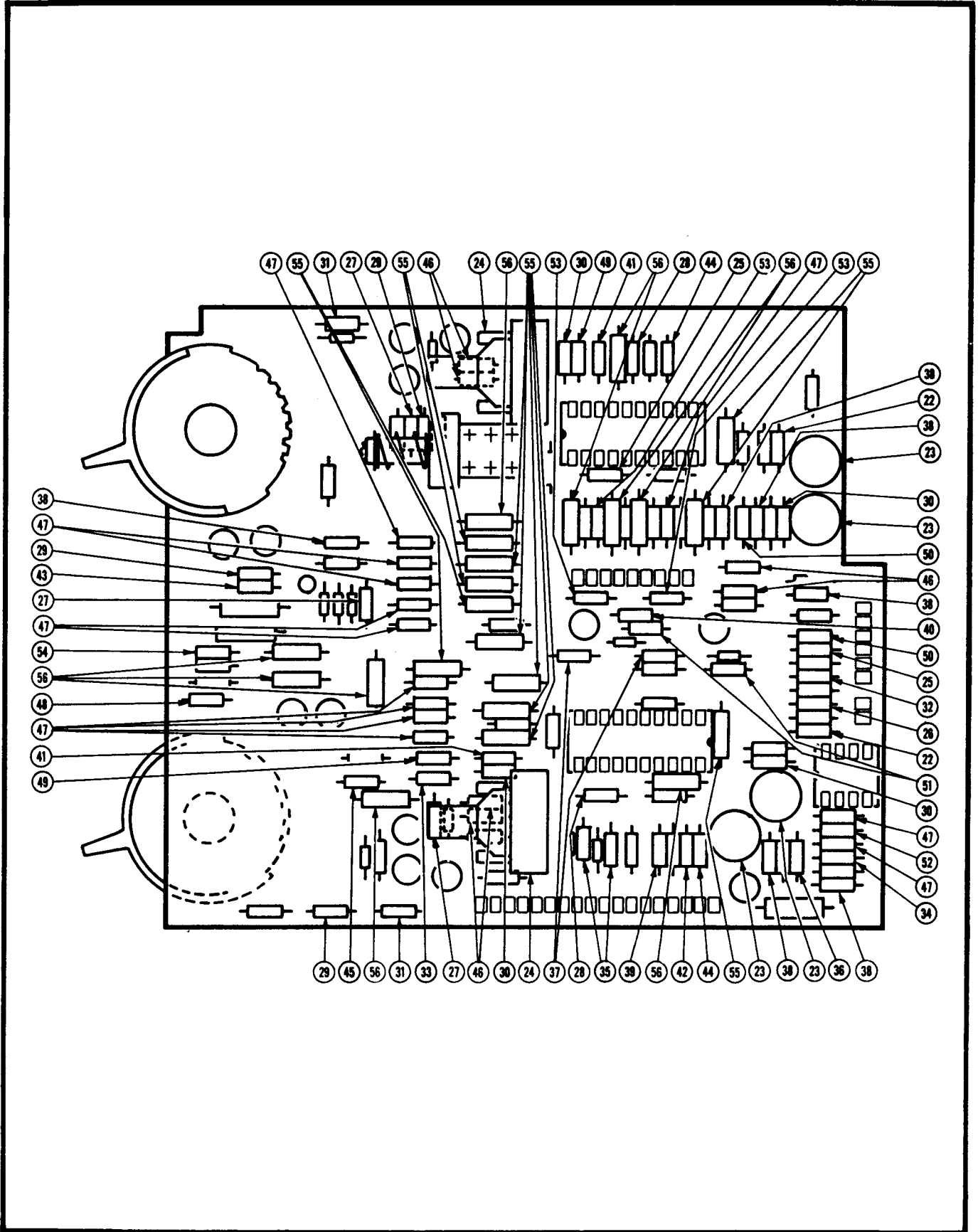

Figure 8-8. Circuit Board Assembly, Trigger (Sheet 2 of 3).

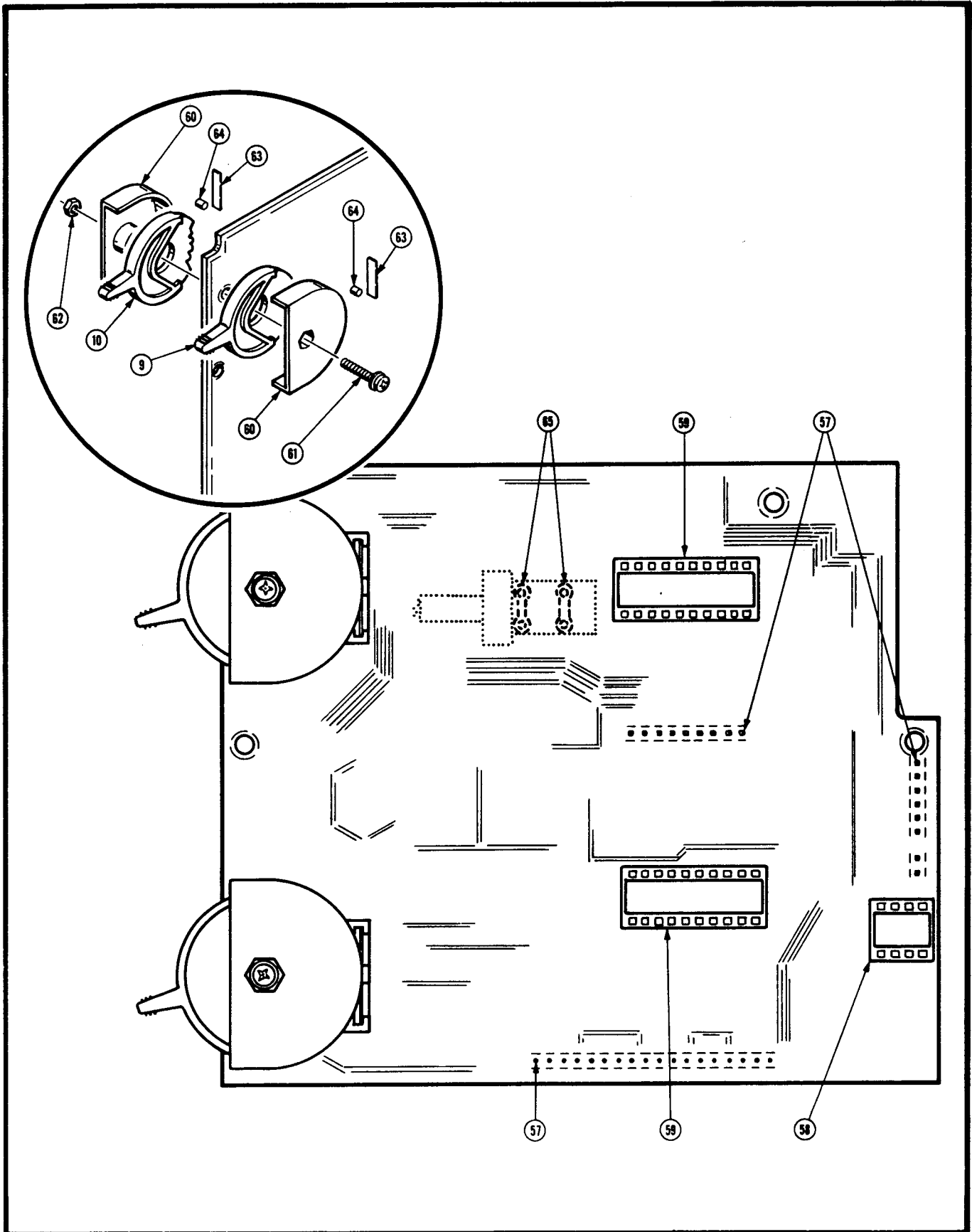

Figure 8-8. Circuit Board Assembly, Trigger (Sheet 3 of 3).

FIG. & INDEX NO.	PART NUMBER	FSCM	DESCRIPTION							UNITS PER ASSY	USABLE ON CODE
			1	2	3	4	5	6	7		
8-8-	670-4847-00	80009	CIRCUIT BOARD ASSEMBLY, Trigger, NHA Figure 7-32							REF	
-1	2N3906	01295	. TRANSISTOR, silicon, PNP (80009 No. 151-0188-00)							1	
-2	151-0190-00	80009	. TRANSISTOR, silicon, NPN.....							2	
-3	151-0472-00	80009	. TRANSISTOR, silicon, NPN.....							2	
-4	151-1042-00	80009	. SEMICONDUCTOR DEVICE, SET, matched pair, FET...							2	
-5	1N4152	07910	. SEMICONDUCTOR DEVICE, silicon, 30V150MA..... (80009 No. 152-0141-02)							9	
-6	CD12676	07910	. SEMICONDUCTOR DEVICE, silicon, 400PIV, 200MA... (80009 No. 152-0246-00)							2	
-7	155-0151-00	80009	. MICROCIRCUIT, DIGITAL, M159, trigger circuit...							2	
-8	156-0067-00	80009	. MICROCIRCUIT, LINEAR, operational amplifier...							1	
-9	214-2292-04	80009	. LEVER, SWITCH, 6 position, 14 degree, with..... contacts							2	
-10	214-2294-02	80009	. LEVER, SWITCH, 4 position, 14 degree, with..... contacts							2	
-11	260-1211-00	80009	. SWITCH, PUSH, DPDT, push-push.....							1	
-12	314-011COK189B	72982	. CAPACITOR, FIXED, CERAMIC DIELECTRIC, 1.8pF, ... 0.1%, 100V (80009 No. 281-0755-00)							1	
-13	314-011COG220K	72982	. CAPACITOR, FIXED, CERAMIC DIELECTRIC, 22pF, 10%, 500V (80009 No. 281-0760-00)							1	
-14	8005H9AADW5R472K	72982	. CAPACITOR, FIXED, CERAMIC DIELECTRIC, 0.0047uF, 10%, 100V (80009 No. 281-0772-00)							11	
-15	8005H9AADW5R103K	72982	. CAPACITOR, FIXED, CERAMIC DIELECTRIC, 0.01uF, .. 10%, 100V (80009 No. 281-0773-00)							19	
-16	390049X5P0151K	72982	. CAPACITOR, FIXED, CERAMIC DIELECTRIC, 150pF, ... 10%, 100V (80009 No. 281-0786-00)							2	
-17	8005-D-COG-150K	72982	. CAPACITOR, FIXED, CERAMIC DIELECTRIC, 15pF, 10%, 100V (80009 No. 281-0797-00)							4	
-18	8005H9AABZ5U104M	72982	. CAPACITOR, FIXED, CERAMIC DIELECTRIC, 0.01uF, ... 20%, 50V (80009 No. 281-0775-00)							1	
-19	390049X5P0820K	72982	. CAPACITOR, FIXED, CERAMIC DIELECTRIC, 82pF, 10%, 100V (80009 No. 281-0792-00)							1	
-20	223K02PT485	19396	. CAPACITOR, FIXED, PLASTIC, 0.022uF, 10%, 200V.... (80009 No. 285-1101-00)							1	
-21	290-0776-00	80009	. CAPACITOR, FIXED, 22uF, +50-10%, 10V.....							4	
-22	CB51G5	01121	. RESISTOR, FIXED, COMPOSITION, 5.1 ohm, 5%, 0.25W (80009 No. 307-0113-00)							2	
-23	91A-50000M	73138	. RESISTOR, VARIABLE, NONWIRE WOUND, 5k ohm, 5%, ... 0.50W (80009 No. 311-1560-00)							4	
-24	3858Z-X03-203E	32997	. RESISTOR, VARIABLE, NONWIRE WOUND, 20k ohm, 10%, 2W (80009 No. 311-1724-00)							2	
-25	CB1005	01121	. RESISTOR, FIXED, COMPOSITION, 10 ohm, 5%, 0.25W.. (80009 No. 315-0100-00)							2	
-26	CB1015	01121	. RESISTOR, FIXED, COMPOSITION, 100 ohm, 5%, 0.25W. (80009 No. 315-0101-00)							1	
-27	CB1025	01121	. RESISTOR, FIXED, COMPOSITION, 1k ohm, 5%, 0.25W.. (80009 No. 315-0102-00)							3	
-28	CB1035	01121	. RESISTOR, FIXED, COMPOSITION, 10k ohm, 5%, 0.25W. (80009 No. 315-0103-00)							2	

AIR FORCE TO33A1-13-496-1
 NAVELEX 0969-LP-170-0010
 Circuit Board Assembly, Trigger

FIG. & INDEX NO.	PART NUMBER	FSCM	DESCRIPTION							UNITS PER ASSY	USABLE ON CODE
			1	2	3	4	5	6	7		
8-8-29	CB1055	01121	.	RESISTOR, FIXED, COMPOSITION, 1M ohm, 5%, 0.25W..						3	
				(80009 No. 315-0105-00)							
-30	CB1325	01121	.	RESISTOR, FIXED, COMPOSITION, 1.3k ohm, 5%, 0.25W						4	
				(80009 No. 315-0132-00)							
-31	CB7505	01121	.	RESISTOR, FIXED, COMPOSITION, 75 ohm, 5%, 0.25W..						2	
				(80009 No. 315-0750-00)							
-32	CB1525	01121	.	RESISTOR, FIXED, COMPOSITION, 1.5k ohm, 5%, 0.25W						1	
				(80009 No. 315-0152-00)							
-33	CB1535	01121	.	RESISTOR, FIXED, COMPOSITION, 15k ohm, 5%, 0.25W.						1	
				(80009 No. 315-0153-00)							
-34	CB1545	01121	.	RESISTOR, FIXED, COMPOSITION, 150k ohm, 5%, 0.25W						1	
				(80009 No. 315-0154-00)							
-35	CB2025	01121	.	RESISTOR, FIXED, COMPOSITION, 2k ohm, 5%, 0.25W..						2	
				(80009 No. 315-0202-00)							
-36	CB2045	01121	.	RESISTOR, FIXED, COMPOSITION, 200k ohm, 5%, 0.25W						1	
				(80009 No. 315-0204-00)							
-37	CB2205	01121	.	RESISTOR, FIXED, COMPOSITION, 22 ohm, 5%, 0.25W..						2	
				(80009 No. 315-0220-00)							
-38	CB2225	01121	.	RESISTOR, FIXED, COMPOSITION, 2.2k ohm, 5%, 0.25W						7	
				(80009 No. 315-0222-00)							
-39	CB2235	01121	.	RESISTOR, FIXED, COMPOSITION, 22k ohm, 5%, 0.25W.						1	
				(80009 No. 315-0223-00)							
-40	CB2715	01121	.	RESISTOR, FIXED, COMPOSITION, 270 ohm, 5%, 0.25W.						2	
				(80009 No. 315-0271-00)							
-41	CB3025	01121	.	RESISTOR, FIXED, COMPOSITION, 3k ohm, 5%, 0.25W..						2	
				(80009 No. 315-0302-00)							
-42	CB3335	01121	.	RESISTOR, FIXED, COMPOSITION, 33k ohm, 5%, 0.25W.						1	
				(80009 No. 315-0333-00)							
-43	CB3355	01121	.	RESISTOR, FIXED, COMPOSITION, 3.3M ohm, 5%, 0.25W						1	
				(80009 No. 315-0335-00)							
-44	CB3625	01121	.	RESISTOR, FIXED, COMPOSITION, 3.6k ohm, 5%, 0.25W						2	
				(80009 No. 315-0362-00)							
-45	CB3905	01121	.	RESISTOR, FIXED, COMPOSITION, 39 ohm, 5%, 0.25W..						1	
				(80009 No. 315-0390-00)							
-46	CB4705	01121	.	RESISTOR, FIXED, COMPOSITION, 47 ohm, 5%, 0.25W..						6	
				(80009 No. 315-0470-00)							
-47	CB4735	01121	.	RESISTOR, FIXED, COMPOSITION, 47k ohm, 5%, 0.25W.						12	
				(80009 No. 315-0473-00)							
-48	CB5145	01121	.	RESISTOR, FIXED, COMPOSITION, 510k ohm, 5%, 0.25W						1	
				(80009 No. 315-0514-00)							
-49	CB5615	01121	.	RESISTOR, FIXED, COMPOSITION, 560 ohm, 5%, 0.25W.						2	
				(80009 No. 315-0561-00)							
-50	CB6205	01121	.	RESISTOR, FIXED, COMPOSITION, 62 ohm, 5%, 0.25W..						2	
				(80009 No. 315-0620-00)							
-51	CB6215	01121	.	RESISTOR, FIXED, COMPOSITION, 620 ohm, 5%, 0.25W.						2	
				(80009 No. 315-0621-00)							
-52	CB6815	01121	.	RESISTOR, FIXED, COMPOSITION, 680 ohm, 5%, 0.25W.						1	
				(80009 No. 315-0681-00)							
-53	CB7505	01121	.	RESISTOR, FIXED, COMPOSITION, 75 ohm, 5%, 0.25W..						3	
				(80009 No. 315-0750-00)							
-54	CB9135	01121	.	RESISTOR, FIXED, COMPOSITION, 91k ohm, 5%, 0.25W.						1	
				(80009 No. 315-0913-00)							

FIG. & INDEX NO.	PART NUMBER	FSCM	DESCRIPTION							UNITS PER ASSY	USABLE ON CODE
			1	2	3	4	5	6	7		
8-8-55	MFF1816G26700F	91637	.	RESISTOR, FIXED, FILM, 2.67k ohm, 1%, 0.125W.....						12	
-56	MFF1816G15000F	91637	.	RESISTOR, FIXED, FILM, 1.5k ohm, 1%, 0.125W.....						10	
-57	47357	22526	.	CONTACT, ELECTRICAL, 0.365 inch long (80009... No. 131-0608-00)						35	
-58	C930802	01295	.	SOCKET, PLUG-IN, microcircuit, 8 contact (80009 No. 136-0514-00)						1	
-59	C932002	73803	.	SOCKET, PLUG-IN, 20 lead, DIP, circuit board.... mount (80009 No. 136-0634-00)						2	
-60	351-0448-01	80009	.	GUIDE, SWITCH, with roller and spring.....						4	
-61	211-0240-00	80009	.	SCREW, ASSEMBLED WASHER, 4-40 X 0.688 inch, ... pnh, steel (AP)						2	
-62	210-0551-00	80009	.	NUT, PLAIN, HEXAGON, 4-40 X 0.25 inch, steel.... (AP)						2	
-63	214-1126-02	80009	.	SPRING, FLAT, red colored.....						4	
-64	214-1127-00	80009	.	ROLLER, DETENT, 0.125 OD X 0.125 inch long..						4	
-65	361-0608-00	80009	.	SPACER, PUSH SWITCH, plastic.....						2	

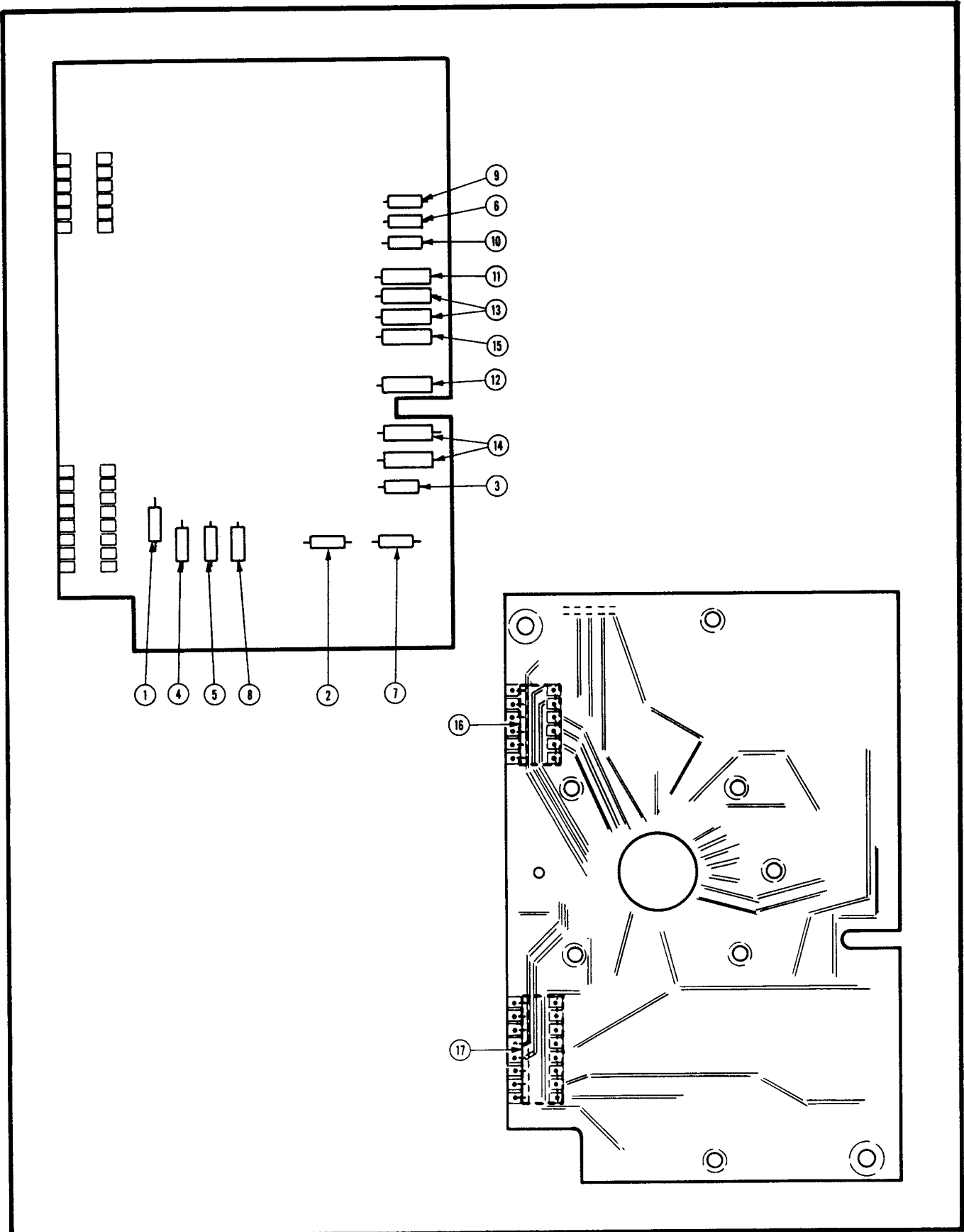

Figure 8-9. Circuit Board Assembly, A-Timing (Sheet 1 of 2).

FIG. & INDEX NO.	PART NUMBER	FSCM	DESCRIPTION							UNITS PER ASSY	USABLE ON CODE
			1	2	3	4	5	6	7		
8-9-	670-4848-00	80009	CIRCUIT BOARD ASSEMBLY, A Timing, NHA Figure... 7-40							REF	
-1	152-0217-00	80009	. SEMICONDUCTOR DEVICE, zener, 0.4W, 8.2V, 5%.....							1	
-2	390049X5P0680K	72982	. CAPACITOR, FIXED, CERAMIC DIELECTRIC, 68pF, 10%, 100V (80009 No. 281-0785-00)							1	
-3	390049X5P0151K	72982	. CAPACITOR, FIXED, CERAMIC DIELECTRIC, 150pF, ... 10%, 100V (80009 No. 281-0786-00)							1	
-4	CB1335	01121	. RESISTOR, FIXED, COMPOSITION, 13k ohm, 5%, 0.25W. (80009 No. 315-0133-00)							1	
-5	CB2235	01121	. RESISTOR, FIXED, COMPOSITION, 22k ohm, 5%, 0.25W. (80009 No. 315-0223-00)							1	
-6	CB2245	01121	. RESISTOR, FIXED, COMPOSITION, 220k ohm, 5%, 0.25W (80009 No. 315-0224-00)							1	
-7	CB3915	01121	. RESISTOR, FIXED, COMPOSITION, 390 ohm, 5%, 0.25W. (80009 No. 315-0391-00)							1	
-8	CB3935	01121	. RESISTOR, FIXED, COMPOSITION, 39k ohm, 5%, 0.25W. (80009 No. 315-0393-00)							1	
-9	CB2255	01121	. RESISTOR, FIXED, COMPOSITION, 2.2m ohm, 5%, 0.25W (80009 No. 315-0225-00)							1	
-10	CB9135	01121	. RESISTOR, FIXED, COMPOSITION, 91k ohm, 5%, 0.25W. (80009 No. 315-0913-00)							1	
-11	MFF1816D75001B	91637	. RESISTOR, FIXED, FILM, 75k ohm, 0.1%, 0.125W..... (80009 No. 321-0373-04)							1	
-12	MFF1816D75002B	91637	. RESISTOR, FIXED, FILM, 750k ohm, 0.1%, 0.125W.... (80009 No. 321-0469-04)							1	
-13	MFF1816D37501B	91637	. RESISTOR, FIXED, FILM, 37.5k ohm, 0.1%, 0.125W... (80009 No. 321-1651-04)							2	
-14	MFF1816D37502B	91637	. RESISTOR, FIXED, FILM, 375k ohm, 0.1%, 0.125W.... (80009 No. 321-1652-04)							2	
-15	HMF188D22503B	91637	. RESISTOR, FIXED, FILM, 2.25M ohm, 0.1%, 0.125W... (80009 No. 321-1653-04)							1	
-16	1-380949-6	00779	. CONNECTOR, RECEPTACLE, 6 pin female (80009 No. 136-0547-00)							1	
-17	1-380949-8	00779	. SOCKET, PLUG-IN, 8 pin female (80009 No..... 136-0632-00)							1	

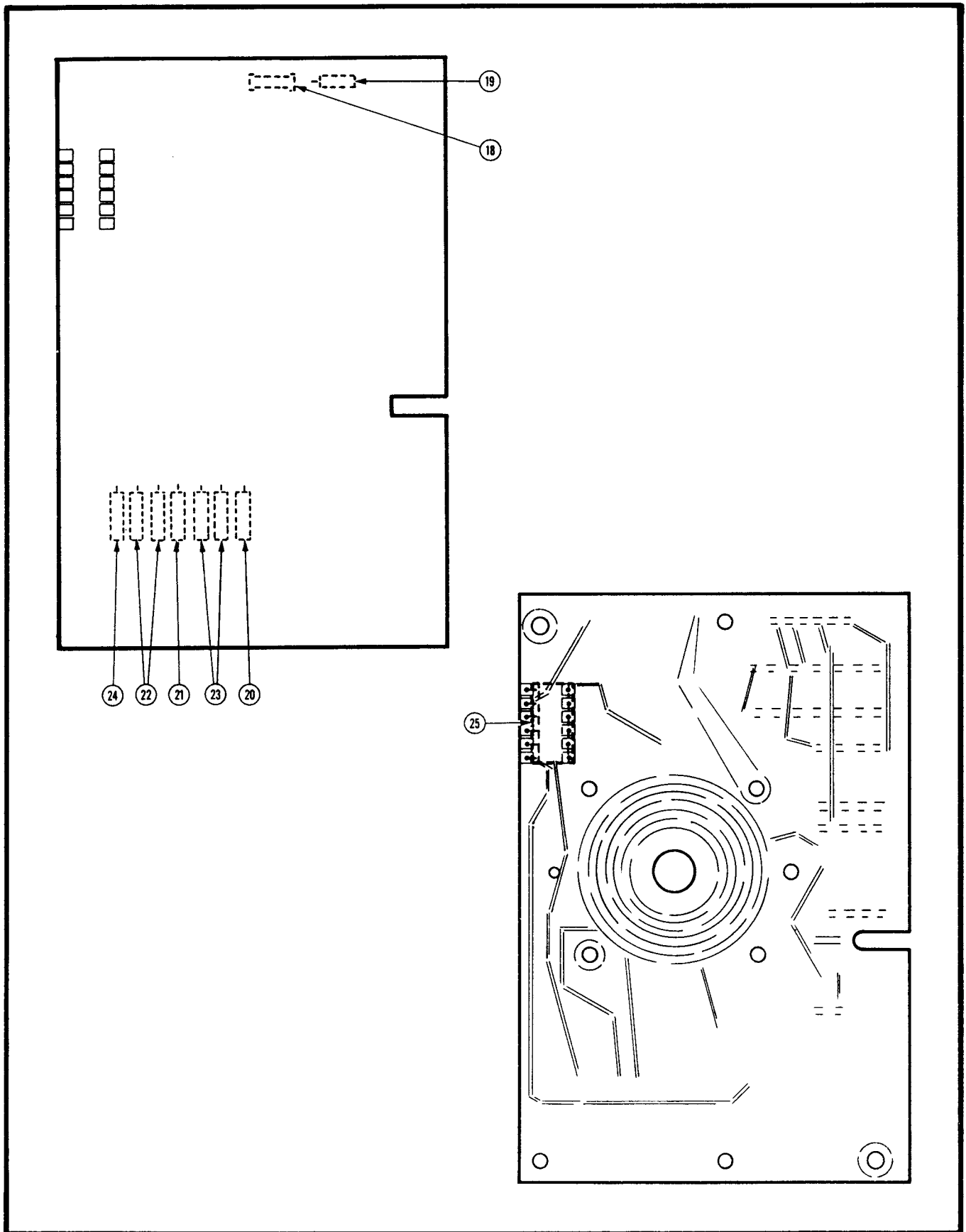

Figure 8-9. Circuit Board Assembly, B-Timing (Sheet 2 of 2).

FIG. & INDEX NO.	PART NUMBER	FSCM	DESCRIPTION							UNITS PER ASSY	USABLE ON CODE
			1	2	3	4	5	6	7		
8-9-	670-3551-02	80009	CIRCUIT BOARD ASSEMBLY, B Timing, NHA Figure.... 7-49							REF	
-18	301-000U2J0680K	72982	. CAPACITOR, FIXED, CERAMIC DIELECTRIC, 68pF, 10%, 500V (80009 No. 281-0549-00)							1	
-19	CB3915	01121	. RESISTOR, FIXED, COMPOSITION, 390 ohm, 5%, 0.25W. (80009 No. 315-0391-00)							1	
-20	MFF1816D75001B	91637	. RESISTOR, FIXED, FILM, 75k ohm, 0.1%, 0.125W.... (80009 No. 321-0373-04)							1	
-21	MFF1816D75002B	91637	. RESISTOR, FIXED, FILM, 750k ohm, 0.1%, 0.125W.... (80009 No. 321-0469-04)							1	
-22	MFF1816D37501B	91637	. RESISTOR, FIXED, FILM, 37.5k ohm, 0.1%, 0.125W... (80009 No. 321-1651-04)							2	
-23	MFF1816D37502B	91637	. RESISTOR, FIXED, FILM, 375k ohm, 0.1%, 0.125W.... (80009 No. 321-1652-04)							2	
-24	HMF188D22503B	91637	. RESISTOR, FIXED, FILM, 2.25M ohm, 0.1%, 0.125W... (80009 No. 321-1653-04)							1	
-25	1-380949-6	00779	. CONNECTOR, RECEPTACLE, 6 pin female. (80009.... No. 136-0547-00)							1	

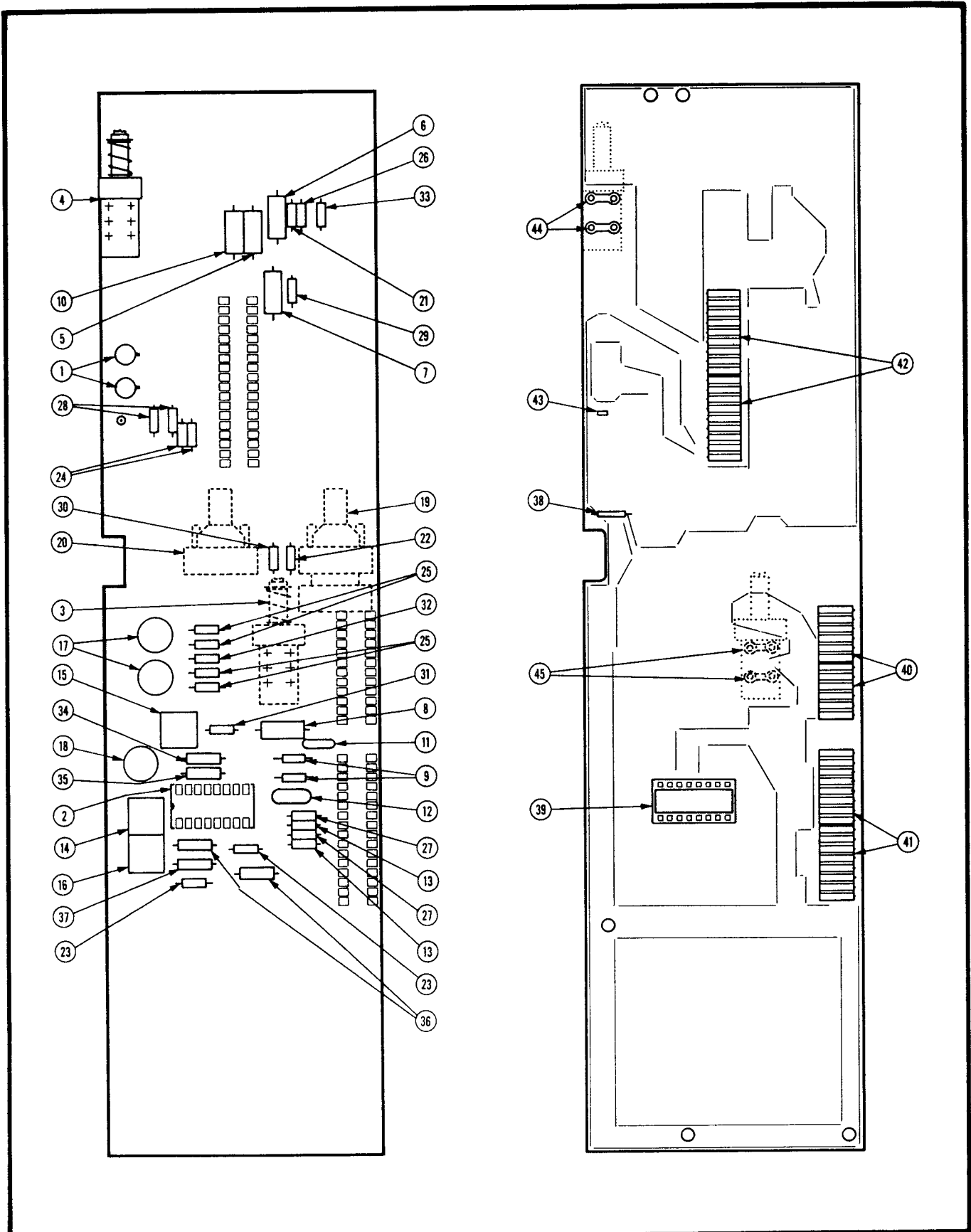

Figure 8-10. Circuit Board Assembly, Horizontal.

FIG. & INDEX NO.	PART NUMBER	FSCM	DESCRIPTION							UNITS PER ASSY	USABLE ON CODE
			1	2	3	4	5	6	7		
8-10-	670-4855-00	80009	CIRCUIT BOARD ASSEMBLY,Horizontal,NHA Figure..							REF	
-1	2N3906	01295	. TRANSISTOR,silicon,PNP (80009 No.....							2	
			151-0188-00)								
-2	155-0124-00	80009	. MICROCIRCUIT,LINEAR,Horizontal Preamplifier.							1	
-3	260-1453-00	80009	. SWITCH,PUSH,1 button.....							1	
-4	2KAB010000	71590	. SWITCH,PUSH,1 button,DPDT (80009 No.....							1	
			260-1771-00)								
-5	314-011COK189B	72982	. CAPACITOR,FIXED,CERAMIC DIELECTRIC,1.8pF,...							1	
			0.1%,100V (80009 No. 281-0755-00)								
-6	314-011COG220K	72982	. CAPACITOR,FIXED,CERAMIC DIELECTRIC,22pF,....								
			10%,500V (80009 No. 281-0760-00)								
-7	314022X5P0101J	72982	. CAPACITOR,FIXED,CERAMIC DIELECTRIC,100pF,5%,							1	
			100V (80009 No. 281-0765-00)								
-8	314022X5P0102M	72982	. CAPACITOR,FIXED,CERAMIC DIELECTRIC,0.001UF,..							1	
			20%,100V (80009 No. 281-0770-00)								
-9	8005H9AABZ5U104M	72982	. CAPACITOR,FIXED,CERAMIC DIELECTRIC,0.1UF,...							2	
			20%,50V (80009 No. 281-0775-00)								
-10	314-011COG150J	72982	. CAPACITOR,FIXED,CERAMIC DIELECTRIC,15pF,5%,.							1	
			500V (80009 No. 281-0787-00)								
-11	36C600	56289	. CAPACITOR,FIXED,CERAMIC DIELECTRIC,0.1UF,...							1	
			+80-20%,25V (80009 No. 283-0081-00)								
-12	D155F201FO	00853	. CAPACITOR,FIXED,MICA DIELECTRIC,200pF,1%,...							1	
			500V (80009 No. 283-0672-00)								
-13	CB47G5	01121	. RESISTOR,FIXED,COMPOSITION,4.7 ohm,5%,0.25W.							2	
			(80009 No. 307-0106-00)								
-14	3386F-T04-101	32997	. RESISTOR,VARIABLE,NONWIRE WOUND,100 ohm,20%,							1	
			0.50W (80009 No. 311-1222-00)								
-15	3386F-T04-501	32997	. RESISTOR,VARIABLE,NONWIRE WOUND,500 ohm,....							1	
			20%,0.50W (80009 No. 311-1224-00)								
-16	3386F-T04-102	32997	. RESISTOR,VARIABLE,NONWIRE WOUND,1k ohm,20%,.							1	
			0.50W (80009 311-1225-00)								
-17	91A-10001M	73138	. RESISTOR,VARIABLE,NONWIRE WOUND,10k ohm,20%,							2	
			0.50W (80009 No. 311-1559-00)								
-18	91A-50000M	73138	. RESISTOR,VARIABLE,NONWIRE WOUND,5k ohm,5%,..							1	
			0.50W (80009 No. 311-1560-00)								
-19	381-CM40951	12697	. RESISTOR,VARIABLE,NONWIRE WOUND,2.5k ohm,...							1	
			5%,2W (80009 No. 311-1722-00)								
-20	381-CM40943	80294	. RESISTOR,VARIABLE,NONWIRE WOUND,1M ohm,20%,.							1	
			2W (80009 No. 311-1728-00)								
-21	CB1055	01121	. RESISTOR,FIXED,COMPOSITION,1M ohm,5%,0.25W..							1	
			(80009 No. 315-0105-00)								
-22	CB1125	01121	. RESISTOR,FIXED,COMPOSITION,1.1k ohm,5%,0.25W							1	
			(80009 No. 315-0112-00)								
-23	CB1835	01121	. RESISTOR,FIXED,COMPOSITION,18k ohm,5%,0.25W.							2	
			(80009 No. 315-0183-00)								
-24	CB2705	01121	. RESISTOR,FIXED,COMPOSITION,27 ohm,5%,0.25W..							2	
			(80009 No. 315-0270-00)								
-25	CB2235	01121	. RESISTOR,FIXED,COMPOSITION,22k ohm,5%,0.25W.							4	
			(80009 No. 315-0223-00)								

AIR FORCE T033A1-13-496-1
 NAVELEX 0969-LP-170-0010
 Circuit Board Assembly, Horizontal

FIG. & INDEX NO.	PART NUMBER	FSCM	DESCRIPTION							UNITS PER ASSY	USABLE ON CODE
			1	2	3	4	5	6	7		
8-10-26	CB3355	01121	.	RESISTOR, FIXED, COMPOSITION, 3.3M ohm, 5%, 0.25W						1	
				(80009 No. 315-0335-00)							
-27	CB4705	01121	.	RESISTOR, FIXED, COMPOSITION, 47 ohm, 5%, 0.25W..						2	
				(80009 No. 315-0470-00)							
-28	CB6815	01121	.	RESISTOR, FIXED, COMPOSITION, 680 ohm, 5%, 0.25W.						2	
				(80009 No. 315-0681-00)							
-29	CB5145	01121	.	RESISTOR, FIXED, COMPOSITION, 510 k ohm, 5%,						1	
				0.25W (80009 No. 315-0514-00)							
-30	CB7525	01121	.	RESISTOR, FIXED, COMPOSITION, 7.5k ohm, 5%, 0.25W						1	
				(80009 No. 315-0752-00)							
-31	CB8205	01121	.	RESISTOR, FIXED, COMPOSITION, 82 ohm, 5%, 0.25W..						1	
				(80009 No. 315-0820-00)							
-32	CB9115	01121	.	RESISTOR, FIXED, COMPOSITION, 910 ohm, 5%, 0.25W.						1	
				(80009 No. 315-0911-00)							
-33	CB9135	01121	.	RESISTOR, FIXED, COMPOSITION, 91k ohm, 5%, 0.25W.						1	
				(80009 No. 315-0913-00)							
-34	MFF1816G130ROF	91637	.	RESISTOR, FIXED, FILM, 130 ohm, 1%, 0.125W.....						1	
				(80009 No. 321-0108-00)							
-35	MFF1816G16900F	91637	.	RESISTOR, FIXED, FILM, 1.69k ohm, 1%, 0.125W.....						1	
				(80009 No. 321-0215-00)							
-36	MFF1816G11501F	91637	.	RESISTOR, FIXED, FILM, 11.5k ohm, 1%, 0.125W.....						2	
				(80009 No. 321-0295-00)							
-37	MFF1816G26101F	91637	.	RESISTOR, FIXED, FILM, 26.1k ohm, 1%, 0.125W.....						1	
				(80009 No. 321-0329-00)							
-38	131-0566-00	80009	.	LINK, TERMINAL CONNECTOR, 0.086 OD X 2.375....						1	
				inch long							
-39	C931602	01295	.	SOCKET, PLUG-IN, 16 contact, low clearance.....						1	
				(80009 No. 136-0260-02)							
-40	1-380949-6	00779	.	CONNECTOR, 6 pin, female (80009 No.....						2	
				136-0547-00)							
-41	1-380949-8	00779	.	SOCKET, PLUG-IN, 8 pin, female (80009 No.....						2	
				136-0632-00)							
-42	1-380949-9	00779	.	SOCKET, PLUG-IN, 9 pin female (80009 No.....						2	
				136-0631-00)							
-43	214-0579-00	80009	.	TERMINAL, TEST POINT, 0.40 inch long.....						2	
-44	361-0384-00	80009	.	SPACER, PUSH BUTTON SWITCH, 0.133 inch long...						2	
-45	361-0608-00	80009	.	SPACER, PUSH BUTTON SWITCH, plastic.....						2	

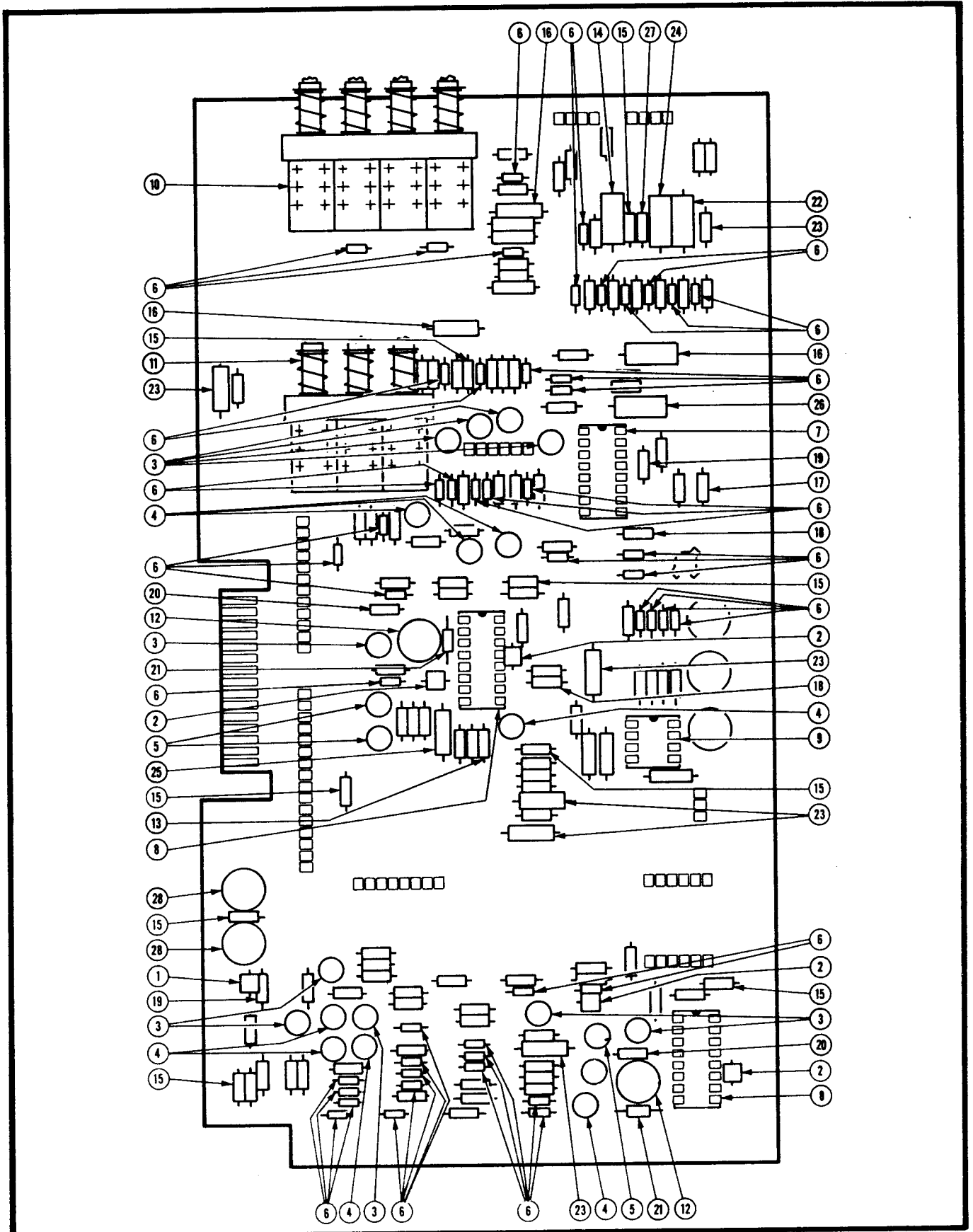

Figure 8-11. Circuit Board Assembly, Sweep (Sheet 1 of 3).

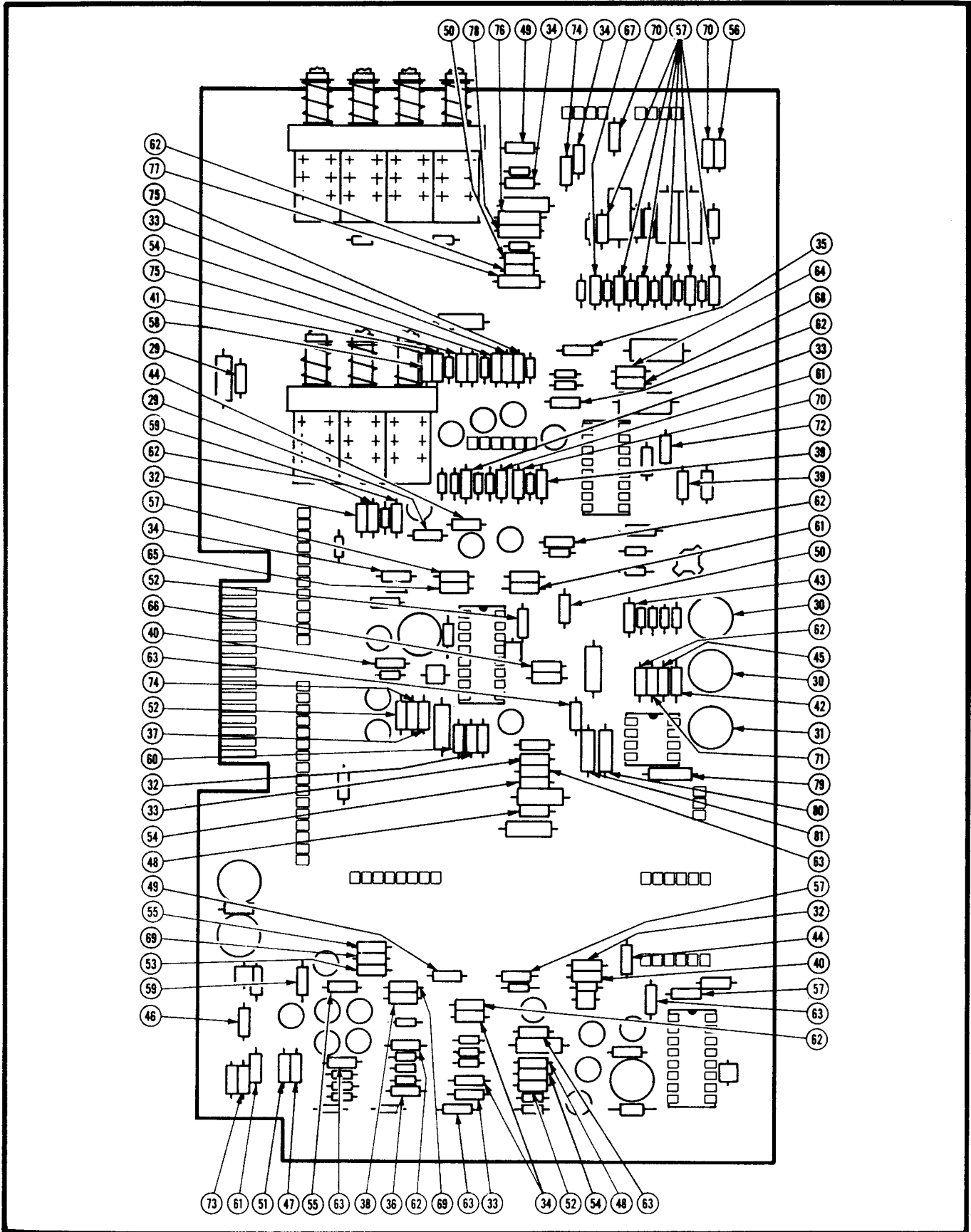

Figure 8-11. Circuit Board Assembly, Sweep (Sheet 2 of 3).

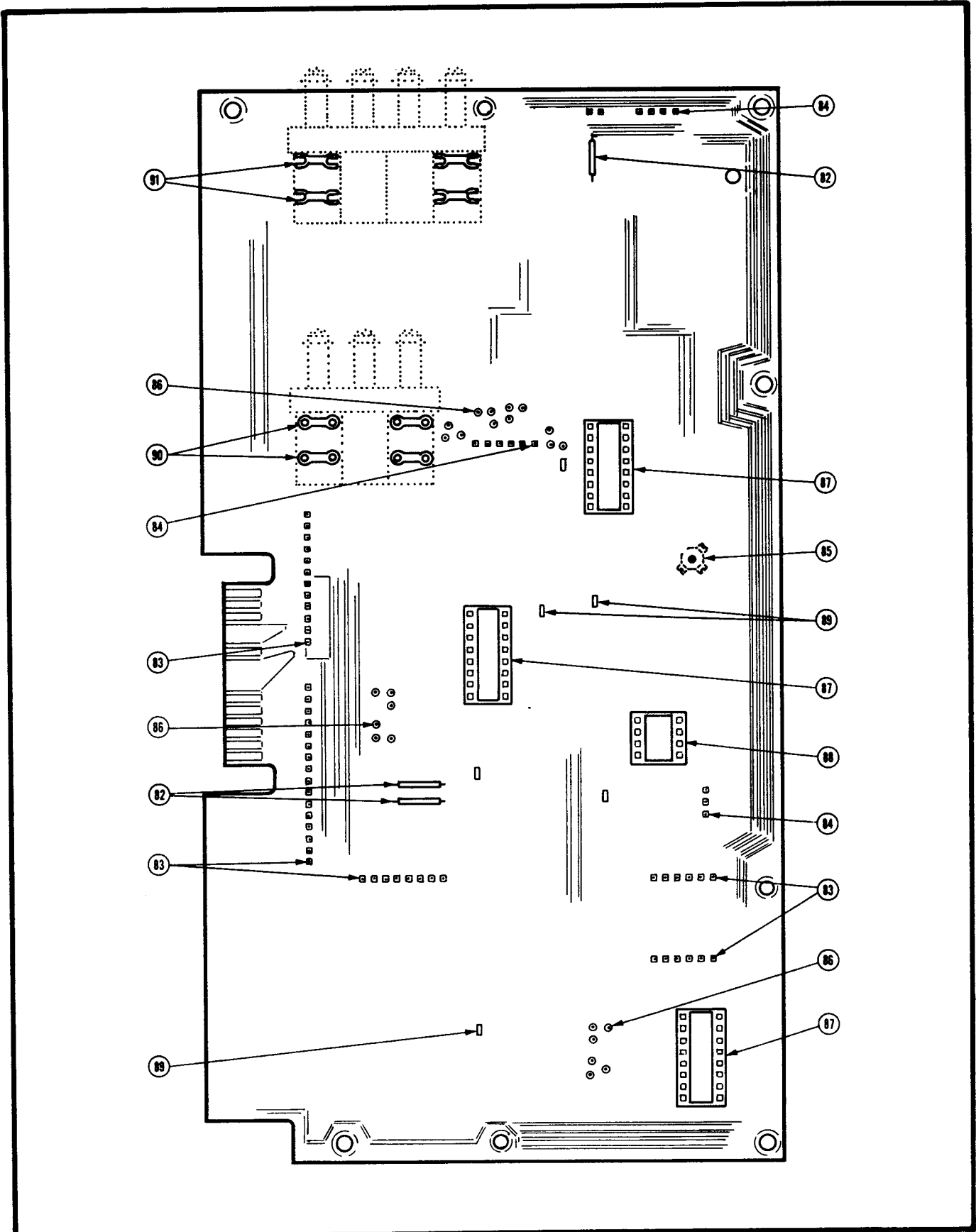

Figure 8-11. Circuit Board Assembly, Sweep (Sheet 3 of 3).

AIR FORCE TO33A1-13-496-1
NAVELEX 0969-LP-170-0010
Circuit Board Assembly, Sweep

FIG. & INDEX NO.	PART NUMBER	FSCM	DESCRIPTION							UNITS PER ASSY	USABLE ON CODE
			1	2	3	4	5	6	7		
8-11-	670-4846-00	80009	CIRCUIT BOARD ASSEMBLY, Sweep, NHA Figure 7-60..							REF	
-1	108-0724-00	80009	. COIL, RADIO FREQUENCY, 12.5NH.....							1	
-2	57-0180-7D-500B	78488	. SHIELDING BEAD, 0.6UH (80009 No. 276-0507-00)							4	
-3	2N3906	01295	. TRANSISTOR, silicon, PNP (80009 No..... 151-0188-00)							10	
-4	151-0190-00	80009	. TRANSISTOR, silicon, NPN.....							8	
-5	151-1042-00	80009	. SEMICONDUCTOR DEVICE, selected, matched pair, . FET							2	
-6	1N4152	07910	. SEMICONDUCTOR DEVICE, silicon, 30V, 150MA..... (80009 No. 152-0141-02)							48	
-7	155-0122-00	80009	. MICROCIRCUIT, DIGITAL, A and B logic, 200 ohm.. per square							1	
-8	155-0123-00	80009	. MICROCIRCUIT, LINEAR, A and B sweep/pickoff...							2	
-9	156-0158-00	80009	. MICROCIRCUIT, LINEAR, dual operational..... amplifier							1	
-10	260-1802-00	80009	. SWITCH, PUSH, 4 button, 2 pole, interlock.....							1	
-11	260-1720-00	80009	. SWITCH, PUSH, 3 button.....							1	
-12	538-011B7-25	72982	. CAPACITOR, VARIABLE, CERAMIC DIELECTRIC, 7-25pF, 350V (80009 No. 281-0160-00)							2	
-13	390049X5P0470K	72982	. CAPACITOR, FIXED, CERAMIC DIELECTRIC, 47pF, 10%, 100V (80009 No. 281-0763-00)							1	
-14	314022X5P0102M	72982	. CAPACITOR, FIXED, CERAMIC DIELECTRIC, 0.001UF, .. 20%, 100V (80009 No. 281-0770-00)							1	
-15	8005H9AADW5R103K	72982	. CAPACITOR, FIXED, CERAMIC DIELECTRIC, 0.01UF, .. 10%, 100V (80009 No. 281-0773-00)							8	
-16	8005H9AABZ5U104M	72982	. CAPACITOR, FIXED, CERAMIC DIELECTRIC, 0.1UF, ... 20%, 50V (80009 No. 281-0775-00)							3	
-17	390049X5P0680K	72982	. CAPACITOR, FIXED, CERAMIC DIELECTRIC, 68PF, 10%, 100V (80009 No. 281-0785-00)							1	
-18	390049X5P0151K	72982	. CAPACITOR, FIXED, CERAMIC DIELECTRIC, 150pF, ... 10%, 100V (80009 No. 281-0786-00)							2	
-19	8005H9AADW5R471K	72982	. CAPACITOR, FIXED, CERAMIC DIELECTRIC, 470pF, ... 10%, 100V (80009 No. 281-0788-00)							2	
-20	8005-D-COG-150K	72982	. CAPACITOR, FIXED, CERAMIC DIELECTRIC, 15pF, 10%, 100V (80009 No. 281-0797-00)							2	
-21	C40A820J	16546	CAPACITOR, FIXED, CERAMIC DIELECTRIC, 82pF, 5%, .. 100V (80009 No. 281-0816-00)							2	
-22	PT605C473M	19396	. CAPACITOR, FIXED, PLASTIC, 0.047UF, 20%, 200V.... (80009 No. 285-1099-00)							1	
-23	162D225X0020CD2	56289	. CAPACITOR, FIXED, ELECTROLYTIC, 2.2UF, 20%, 20V.. (80009 No. 290-0136-00)							6	
-24	150D106X0015B2	56289	. CAPACITOR, FIXED, ELECTROLYTIC, 10UF, 20%, 15V... (80009 No. 290-0167-00)							1	
-25	162D105X0035CD2	56289	. CAPACITOR, FIXED, ELECTROLYTIC, 1UF, 20%, 35V.... (80009 No. 290-0267-00)							1	
-26	162D274X9035BC2	56289	. CAPACITOR, FIXED, ELECTROLYTIC, 0.27UF, 10%, 35V.. (80009 No. 290-0288-00)							1	
-27	150D564X0100A2	56289	. CAPACITOR, FIXED, ELECTROLYTIC, 0.56UF, 20%, 100V (80009 No. 290-0327-00)							1	
-28	290-0746-00	80009	. CAPACITOR, FIXED, ELECTROLYTIC, 47UF, +50-10%, .. 16V							2	

FIG. & INDEX NO.	PART NUMBER	FSCM	DESCRIPTION							UNITS PER ASSY	USABLE ON CODE	
			1	2	3	4	5	6	7			
8-11-29	CB47G5	01121	.	RESISTOR, FIXED, COMPOSITION, 4.7 ohm, 5%, 0.25W.							2	
				(80009 No. 307-0106-00)								
-30	91A-10001M	73138	.	RESISTOR, VARIABLE, NONWIRE WOUND, 10k ohm, 20%,							2	
				0.50W (80009 No. 311-1559-00)								
-31	91A-25000M	73138	.	RESISTOR, VARIABLE, NONWIRE WOUND, 2.5k ohm, ...							1	
				20%, 0.50W (80009 No. 311-1561-00)								
-32	CB1015	01121	.	RESISTOR, FIXED, COMPOSITION, 100 ohm, 5%, 0.25W.							3	
				(80009 No. 315-0101-00)								
-33	CB1025	01121	.	RESISTOR, FIXED, COMPOSITION, 1k ohm, 5%, 0.25W..							4	
				(80009 No. 315-0102-00)								
-34	CB1035	01121	.	RESISTOR, FIXED, COMPOSITION, 10k ohm, 5%, 0.25W.							5	
				(80009 No. 315-0103-00)								
-35	CB1045	01121	.	RESISTOR, FIXED, COMPOSITION, 100k ohm, 5%, 0.25W							1	
				(80009 No. 315-0104-00)								
-36	CB1125	01121	.	RESISTOR, FIXED, COMPOSITION, 1.1k ohm, 5%, 0.25W							1	
				(80009 No. 315-0112-00)								
-37	CB1135	01121	.	RESISTOR, FIXED, COMPOSITION, 11k ohm, 5%, 0.25W.							1	
				(80009 No. 315-0113-00)								
-38	CB1215	01121	.	RESISTOR, FIXED, COMPOSITION, 120 ohm, 5%, 0.25W.							1	
				(80009 No. 315-0121-00)								
-39	CB1225	01121	.	RESISTOR, FIXED, COMPOSITION, 1.2k ohm, 5%, 0.25W.							2	
				(80009 No. 315-0122-00)								
-40	CB1235	01121	.	RESISTOR, FIXED, COMPOSITION, 12k ohm, 5%, 0.25W..							2	
				(80009 No. 315-0123-00)								
-41	CB1325	01121	.	RESISTOR, FIXED, COMPOSITION, 1.3k ohm, 5%, 0.25W.							1	
				(80009 No. 315-0132-00)								
-42	CB1525	01121	.	RESISTOR, FIXED, COMPOSITION, 1.5k ohm, 5%, 0.25W.							1	
				(80009 No. 315-0152-00)								
-43	CB1535	01121	.	RESISTOR, FIXED, COMPOSITION, 15k ohm, 5%, 0.25W..							1	
				(80009 No. 315-0153-00)								
-44	CB1825	01121	.	RESISTOR, FIXED, COMPOSITION, 1.8k ohm, 5%, 0.25W.							2	
				(80009 No. 315-0182-00)								
-45	CB1835	01121	.	RESISTOR, FIXED, COMPOSITION, 18k ohm, 5%, 0.25W..							1	
				(80009 No. 315-0183-00)								
-46	CB2005	01121	.	RESISTOR, FIXED, COMPOSITION, 20 ohm, 5%, 0.25W...							1	
				(80009 No. 315-0200-00)								
-47	CB2015	01121	.	RESISTOR, FIXED, COMPOSITION, 200 ohm, 5%, 0.25W..							1	
				(80009 No. 315-0201-00)								
-48	CB2035	01121	.	RESISTOR, FIXED, COMPOSITION, 20k ohm, 5%, 0.25W..							2	
				(80009 No. 315-0203-00)								
-49	CB2215	01121	.	RESISTOR, FIXED, COMPOSITION, 220 ohm, 5%, 0.25W..							2	
				(80009 No. 315-0221-00)								
-50	CB2225	01121	.	RESISTOR, FIXED, COMPOSITION, 2.2k ohm, 5%, 0.25W.							2	
				(80009 No. 315-0222-00)								
-51	CB2235	01121	.	RESISTOR, FIXED, COMPOSITION, 22k ohm, 5%, 0.25W..							1	
				(80009 No. 315-0223-00)								
-52	CB2725	01121	.	RESISTOR, FIXED, COMPOSITION, 2.7k ohm, 5%, 0.25W.							3	
				(80009 No. 315-0272-00)								
-53	CB3015	01121	.	RESISTOR, FIXED, COMPOSITION, 300 ohm, 5%, 0.25W..							1	
				(80009 No. 315-0301-00)								

AIR FORCE TO33A1-13-496-1
 NAVELEX 0969-LP-170-0010
 Circuit Board Assembly, Sweep

FIG. & INDEX NO.	PART NUMBER	FSCM								UNITS PER ASSY	USABLE ON CODE
			1	2	3	4	5	6	7		
8-11-54	CB3035	01121	3	
			. RESISTOR, FIXED, COMPOSITION, 30k ohm, 5%, 0.25W. (80009 No. 315-0303-00)								
-55	CB3305	01121	2	
			. RESISTOR, FIXED, COMPOSITION, 33 ohm, 5%, 0.25W.. (80009 No. 315-0330-00)								
-56	CB3315	01121	1	
			. RESISTOR, FIXED, COMPOSITION, 330 ohm, 5%, 0.25W. (80009 No. 315-0331-00)								
-57	CB3325	01121	9	
			. RESISTOR, FIXED, COMPOSITION, 3.3k ohm, 5%, 0.25W (80009 No. 315-0332-00)								
-58	CB3625	01121	1	
			. RESISTOR, FIXED, COMPOSITION, 3.6k ohm, 5%, 0.25W (80009 No. 315-0362-00)								
-59	CB3915	01121	2	
			. RESISTOR, FIXED, COMPOSITION, 390 ohm, 5%, 0.25W. (80009 No. 315-0391-00)								
-60	CB4705	01121	1	
			. RESISTOR, FIXED, COMPOSITION, 47 ohm, 5%, 0.25W.. (80009 No. 315-0470-00)								
-61	CB4715	01121	3	
			. RESISTOR, FIXED, COMPOSITION, 470 ohm, 5%, 0.25W. (80009 No. 315-0471-00)								
-62	CB4725	01121	7	
			. RESISTOR, FIXED, COMPOSITION, 4.7k ohm, 5%, 0.25W (80009 No. 315-0472-00)								
-63	CB4735	01121	6	
			. RESISTOR, FIXED, COMPOSITION, 47k ohm, 5%, 0.25W. (80009 No. 315-0473-00)								
-64	CB4745	01121	1	
			. RESISTOR, FIXED, COMPOSITION, 470 k ohm, 5%, 0.25W (80009 No. 315-0474-00)								
-65	CB4755	01121	1	
			. RESISTOR, FIXED, COMPOSITION, 4.7M ohm, 5%, 0.25W (80009 No. 315-0475-00)								
-66	CB5605	01121	1	
			. RESISTOR, FIXED, COMPOSITION, 56 ohm, 5%, 0.25W.. (80009 No. 315-0560-00)								
-67	CB5635	01121	1	
			. RESISTOR, FIXED, COMPOSITION, 56k ohm, 5%, 0.25W. (80009 No. 315-0563-00)								
-68	CB5645	01121	1	
			. RESISTOR, FIXED, COMPOSITION, 560k ohm, 5%, 0.25W (80009 No. 315-0564-00)								
-69	CB6225	01121	2	
			. RESISTOR, FIXED, COMPOSITION, 6.2k ohm, 5%, 0.25W (80009 No. 315-0622-00)								
-70	CB6815	01121	3	
			. RESISTOR, FIXED, COMPOSITION, 680 ohm, 5%, 0.25W. (80009 No. 315-0681-00)								
-71	CB6845	01121	1	
			. RESISTOR, FIXED, COMPOSITION, 680k ohm, 5%, 0.25W (80009 No. 315-0684-00)								
-72	CB7525	01121	1	
			. RESISTOR, FIXED, COMPOSITION, 7.5k ohm, 5%, 0.25W (80009 No. 315-0752-00)								
-73	CB8215	01121	1	
			. RESISTOR, FIXED, COMPOSITION, 820 ohm, 5%, 0.25W. (80009 No. 315-0821-00)								
-74	CB8225	01121	2	
			. RESISTOR, FIXED, COMPOSITION, 8.2k ohm, 5%, 0.25W (80009 No. 315-0822-00)								
-75	CB9105	01121	2	
			. RESISTOR, FIXED, COMPOSITION, 91 ohm, 5%, 0.25W.. (80009 No. 315-0910-00)								
-76	MFF1816G22100F	91637	1	
			. RESISTOR, FIXED, FILM, 2.21k ohm, 1%, 0.125W..... (80009 No. 321-0226-00)								
-77	MFF1816G23700F	91637	1	
			. RESISTOR, FIXED, FILM, 2.37k ohm, 1%, 0.125W..... (80009 No. 321-0229-00)								
-78	MFF1816G33200F	91637	1	
			. RESISTOR, FIXED, FILM, 3.32k ohm, 1%, 0.125W..... (80009 No. 321-0243-00)								

FIG. & INDEX NO.	PART NUMBER	FSCM	DESCRIPTION							UNITS PER ASSY	USABLE ON CODE
			1	2	3	4	5	6	7		
8-11-79	MFF1816G45300F	91637	.	RESISTOR, FIXED, FILM, 4.53k ohm, 1%, 0.125W.....						1	
				(80009 No. 321-0256-00)							
-80	MFF1816G56200F	91637	.	RESISTOR, FIXED, FILM, 5.62k ohm, 1%, 0.125W.....						1	
				(80009 No. 321-0265-00)							
-81	MFF1816G84501F	91637	.	RESISTOR, FIXED, FILM, 84.5k ohm, 1%, 0.125W.....						1	
				(80009 No. 321-0378-00)							
-82	131-0566-00	80009	.	LINK, TERMINAL CONNECTOR, 0.086 OD X 2.375....						3	
				inch long							
-83	47350	22526	.	CONTACT, ELECTRICAL, 0.46 inch long (80009 No..						48	
				131-0589-00)							
-84	47357	22526	.	CONTACT, ELECTRICAL, 0.365 inch long (80009 No.						15	
				131-0608-00)							
-85	131-1003-00	80009	.	CONNECTOR, BODY, circuit board mount, 3 prong...						1	
-86	75060	22526	.	SOCKET, PIN TERMINAL, 0.188 inch long (80009...						25	
				No. 136-0252-04)							
-87	C931602	01295	.	SOCKET, PLUG-IN, 16 contact, low clearance.....						3	
				(80009 No. 136-0260-02)							
-88	C930802	01295	.	SOCKET, PLUG-IN, microcircuit, 8 contact (80009.						1	
				No. 136-0514-00)							
-89	214-0579-00	80009	.	TERMINAL, TEST POINT, 0.40 inch long.....						7	
-90	361-0385-00	80009	.	SPACER, PUSH BUTTON SWITCH, 0.164 inch long....						4	
-91	J-64281	71590	.	SPACER, SWITCH, plastic (80009 No. 361-0542-00)						4	

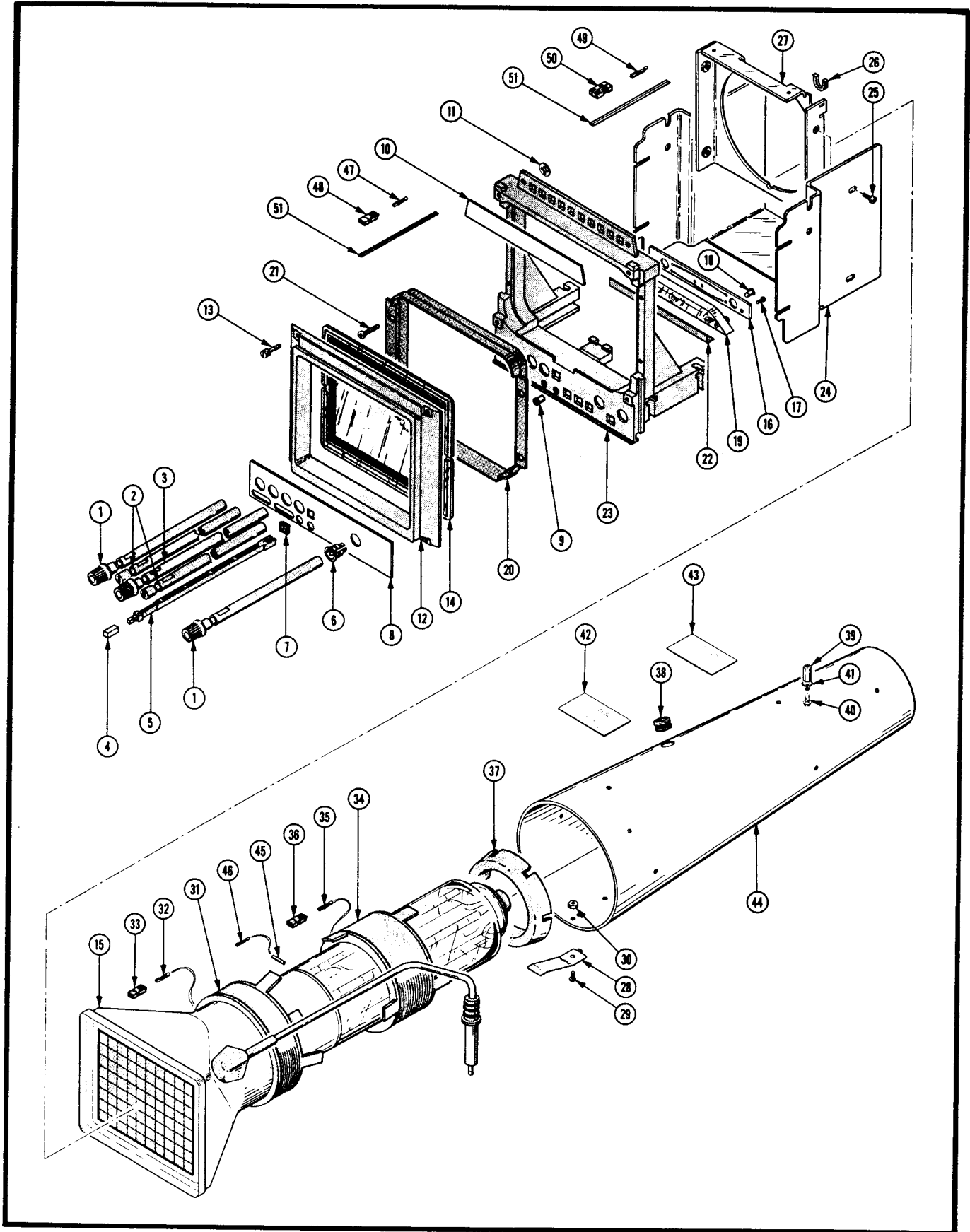

Figure 8-12. Electron Tube Assembly.

FIG. & INDEX NO.	PART NUMBER	FSCM	DESCRIPTION							UNITS PER ASSY	USABLE ON CODE
			1	2	3	4	5	6	7		
8-12-	-----	80009	ELECTRON TUBE ASSEMBLY,NHA Figure 1-7.....							REF	
-1	384-1350-02	80009	. KNOB,0.28 OD X 4.415 inch long,plastic.....							2	
-2	384-1348-00	80009	. EXTENSION SHAFT,0.25 OD X 6.623 inch long,.. plastic							2	
-3	384-1350-00	80009	. EXTENSION SHAFT,0.2 OD X 12.215 inch long,.. with Knob							1	
-4	366-1559-00	80009	. PUSH BUTTON,gray.....							1	
-5	384-1129-00	80009	. EXTENSION SHAFT,5.607 inch long.....							1	
-6	358-0550-00	80009	. BUSHING,SHAFT,0.15 ID X 0.3 inch OD,plastic.							5	
-7	426-1072-00	80009	. FRAME,PUSH BUTTON,plastic.....							1	
-8	333-1994-01	80009	. PANEL,FRONT,electron tube.....							1	
-9	450-4352-01-0318	71279	. JACK,TIP,gray (80009 No. 136-0387-00).....							2	
-10	334-3054-00	80009	. PLATE,IDENTIFICATION.....							1	
-11	354-0195-00	80009	. RING,RETAINING.....							2	
-12	343-0523-00	80009	. RETAINER,IMPLOSION,5.65 X 4.705 inch,plastic							1	
-13	213-0313-00	80009	. . THUMBSCREW,4-40 X 0.45 inch,knurled.....							4	
-14	337-2122-00	80009	. SHIELD,IMPLOSION,blue.....							1	
-15	154-0777-00	80009	. ELECTRON TUBE,P31.....							1	
-16	388-4703-00	80009	. CIRCUIT BOARD,scale illumination.....							1	
-17	211-0001-00	80009	. SCREW,MACHINE,2-56 X 0.25 inch,pnh,steel.... (AP)							2	
-18	2112D	08806	. LAMP,INCANDESCENT,6.3V,200MA (80009 No..... 150-0129-00)							2	
-19	378-0614-00	80009	. REFLECTOR,LIGHT,molded plastic.....							1	
-20	386-3336-00	80009	. SUPPORT,ELECTRON TUBE,front.....							1	
-21	213-0183-00	80009	. SCREW,TAPPING,THREAD FORMING,6-32 X 0.25.... inch,pnh,steel (AP)							4	
-22	337-2262-00	80009	. SHIELD,LIGHT,electron tube scale.....							1	
-23	426-1240-00	80009	. FRAME SECTION,SCOPE,electron tube front..... support							1	
-24	337-2207-00	80009	. SHIELD,ELECTRICAL,vertical and horizontal... support							1	
-25	211-0534-00	80009	. SCREW,ASSEMBLED WASHER,6-32 X 0.312 inch,.. pnh,steel (AP)							4	
-26	348-0171-00	80009	. GROMMET,PLASTIC,u-shaped.....							1	
-27	386-3518-00	80009	. SUPPORT,SHIELD,electron tube,front.....							1	
-28	214-2270-00	80009	. SPRING,GROUND,electron tube to shield.....							1	
-29	211-0007-00	80009	. SCREW,MACHINE,4-40 X 0.188 inch,pnh,steel... (AP)							1	
-30	210-0586-00	80009	. NUT,PLAIN,EXTENDED WASHER,4-40 X 0.25 inch,.. steel (AP)							1	
-31	108-0818-00	80009	. COIL,TUBE DEFLECTION,trace rotation.....							1	
-32	47439	22526	. . CONTACT,ELECTRICAL,0.48 inch long,22-26... AWG wire (80009 No. 131-0707-00)							2	
-33	352-0169-01	80009	. . CONNECTOR BODY,PLUG,ELECTRICAL,2 wire..... brown							1	
-34	108-0819-00	80009	. COIL,TUBE DEFLECTION,x-y alignment.....							1	
-35	47439	22526	. . CONTACT,ELECTRICAL,0.48 inch long,22-26... AWG wire (80009 No. 131-0707-00)							2	
-36	352-0169-00	80009	. . CONNECTOR BODY,PLUG,ELECTRICAL,2 wire..... black (80009 No. 352-0169-00)							1	

AIR FORCE TO33A1-13-496-1
 NAVELEX 0969-LP-170-0010
 Electron Tube Assembly

FIG. & INDEX NO.	PART NUMBER	FSCM	DESCRIPTION							UNITS PER ASSY	USABLE ON CODE
			1	2	3	4	5	6	7		
8-12-37	386-3305-00	80009	.	SUPPORT,ELECTRON TUBE,rear.....						1	
-38	763	70485	.	GROMMET,RUBBER,0.281 ID X 0.563 inch OD.....						1	
				(80009 No. 348-0004-00)							
-39	129-0308-00	80009	.	POST,ELECTRICAL-MECHANICAL,0.25 hex X 0.465.						1	
				inch long							
-40	211-0116-00	80009	.	SCREW,ASSEMBLED WASHER,4-40 X 0.312 inch,...						1	
				pnh,brass (AP)							
-41	1104-00-00-0541C	78189	.	WASHER,LOCK,external,0.123 ID X 0.245 inch..						1	
				OD,steel (AP)							
-42	334-1379-00	80009	.	LABEL,electron tube,adhesive back,warning...						1	
-43	334-1951-00	80009	.	LABEL,electron tube,adhesive back,warning...						1	
-44	337-2124-00	80009	.	SHIELD,ELECTRON TUBE.....						1	
-45	131-0472-00	80009	.	CLIP,ELECTRICAL,female.....						4	
-46	46231	22526	.	CONTACT,ELECTRICAL,0.577 inch long,22-26....						4	
				AWG, wire (80009 No. 131-0621-00)							
-47	47439	22526	.	CONTACT,ELECTRICAL,0.48 inch long,22-26 AWG.						2	
				wire (80009 No. 131-0707-00)							
-48	352-0169-00	80009	.	CONNECTOR BODY,PLUG,ELECTRICAL,2 wire black.						1	
-49	46231	22526	.	CONTACT,ELECTRICAL,0.577 inch long,22-26 AWG						2	
				wire (80009 No. 131-0621-00)							
-50	352-0198-00	80009	.	CONNECTOR BODY,PLUG,ELECTRICAL,2 wire black.						1	
-51	175-0825-00	80009	.	WIRE,ELECTRICAL,2 wire ribbon,1.450 feet....						AR	
				long							

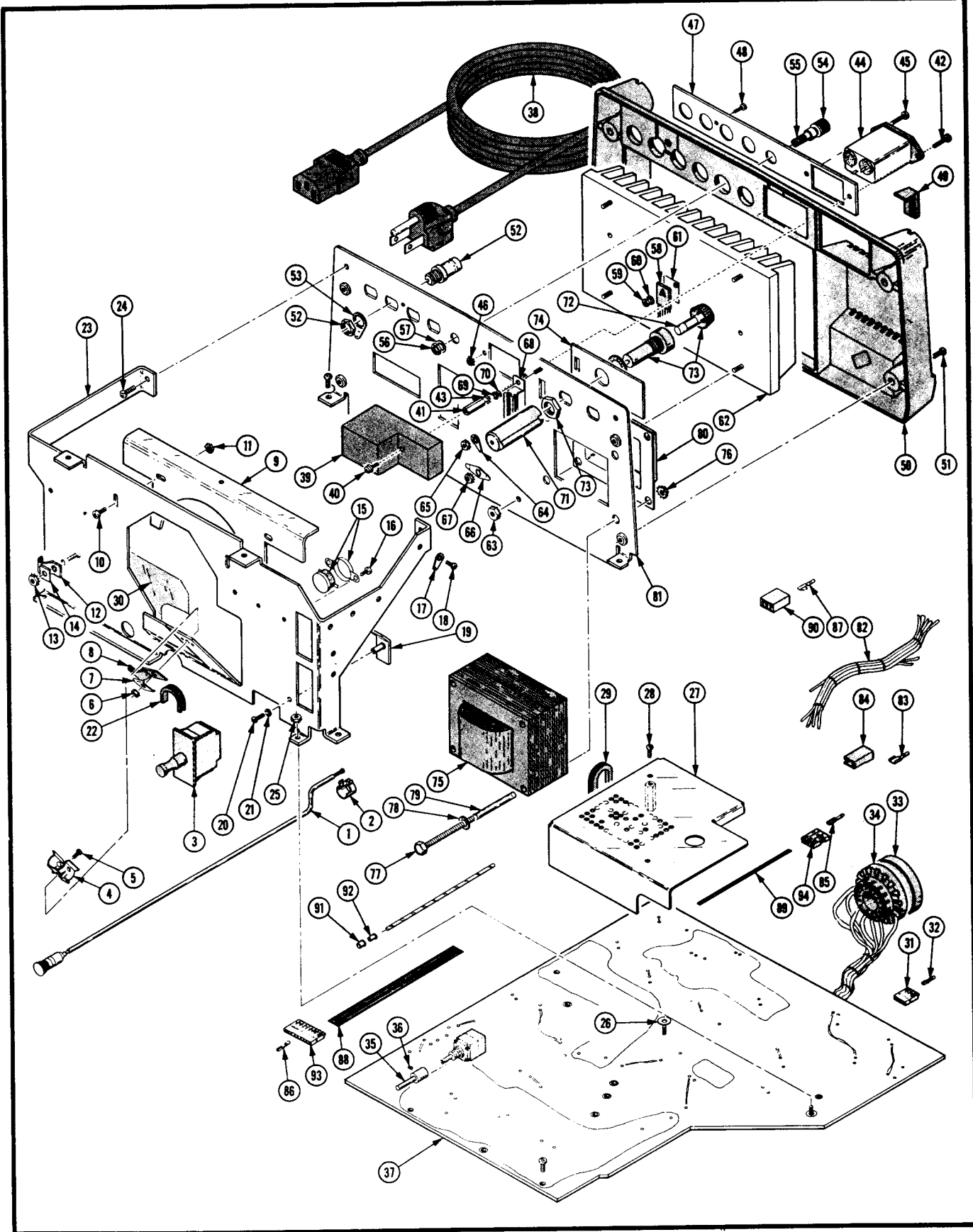

Figure 8-13. Main Chassis Assembly.

AIR FORCE TO33A1-13-496-1
 NAVELEX 0969-LP-170-0010
 Main Chassis Assembly

FIG. & INDEX NO.	PART NUMBER	FSCM	DESCRIPTION							UNITS PER ASSY	USABLE ON CODE
			1	2	3	4	5	6	7		
8-13-	-----	80009	MAIN CHASSIS ASSEMBLY,NHA Figure 1-11.....							REF	
-1	384-1311-01	80009	. EXTENSION SHAFT,0.125 OD X 11.835 inch long, with knob							1	
-2	376-0127-00	80009	. COUPLER,SHAFT,plastic.....							1	
-3	2DM301	91929	. SWITCH,PUSH-PULL,10A,250VAC (80009 No..... 260-1222-00)							1	
-4	4522-5050-2C	86928	. CLIP,ELECTRICAL,component mounting (80009... No. 344-0250-00)							1	
-5	211-0097-00	80009	. SCREW,MACHINE,4-40 X 0.312 inch,pnh,steel... (AP)							1	
-6	210-0586-00	80009	. NUT,PLAIN,EXTENDED WASHER,4-40 X 0.25 inch,.. steel (AP)							1	
-7	C191	95987	. WASHER,LOOP CLAMP,for 0.50 inch wide clamp,.. steel (AP) (80009 No. 210-0863-00)							1	
-8	5-16-6BH	95987	. CLAMP,LOOP,0.287 inch diameter (80009 No.... 343-0042-00)							1	
-9	386-3519-00	80009	. SUPPORT,ELECTRON TUBE SHIELD,rear.....							1	
-10	211-0534-00	80009	. SCREW,ASSEMBLED WASHER,6-32 X 0.312 inch,... pnh,steel (AP)							2	
-11	210-0457-00	80009	. NUT,PLAIN,EXTENDED WASHER,6-32 X 0.312 inch, steel (AP)							2	
-12	5-16-6BH	95987	. CLAMP,LOOP,0.287 inch diameter (80009 No.... 343-0042-00)							1	
-13	210-0457-00	80009	. NUT,PLAIN,EXTENDED WASHER,6-32 X 0.312 inch, steel (AP)							1	
-14	C191	95987	. WASHER,LOOP CLAMP,for 0.50 inch wide clamp,.. steel (AP) (80009 No. 210-0863-00)							1	
-15	20704-L67-322	01295	. SWITCH,THERMOSTATIC,normally closed,10A,.... 24V (80009 No. 260-0724-01)							1	
-16	213-0124-00	80009	. SCREW,TAPPING,THREAD FORMING,6-20 X 0.250... inch,pnh,steel (AP)							2	
-17	2104-06-00-2520N	78189	. TERMINAL,LUG,SE #6 (80009 No. 210-0202-00)..							1	
-18	211-0504-00	80009	. SCREW,MACHINE,6-32 X 0.25 inch,pnh,steel.... (AP)							1	
-19	343-0528-00	80009	. CLAMP,TRANSISTOR,retainer.....							1	
-20	211-0012-00	80009	. SCREW,MACHINE,4-40 X 0.375 inch,pnh,steel... (AP)							1	
-21	1204-00-00-0541C	78189	. WASHER,LOCK,internal,0.12 ID X 0.26 inch OD, steel (AP) (80009 No. 210-0004-00)							1	
-22	348-0141-00	80009	. GROMMET,PLASTIC,u-shaped.....							1	
-23	441-1260-00	80009	. CHASSIS,ELECTRONIC EQUIPMENT,power supply...							1	
-24	211-0534-00	80009	. SCREW,ASSEMBLED WASHER,6-32 X 0.312 inch,... pnh,steel (AP)							2	
-25	210-0586-00	80009	. NUT,PLAIN,EXTENDED WASHER,4-40 X 0.25 inch,.. steel (AP)							2	
-26	210-0994-00	80009	. WASHER,FLAT,0.125 ID X 0.25 inch OD,steel...							1	
-27	337-2128-00	80009	. SHIELD,ELECTRICAL,high voltage.....							1	
-28	211-0007-00	80009	. SCREW,MACHINE,4-40 X 0.188 inch,pnh,steel... (AP)							2	
-29	348-0141-00	80009	. GROMMET,PLASTIC,u-shaped.....							1	

FIG. & INDEX NO.	PART NUMBER	FSCM	DESCRIPTION							UNITS PER ASSY	USABLE ON CODE
			1	2	3	4	5	6	7		
8-13-30	342-0297-00	80009	1	
	136-0624-00	80009	1	
-31	352-0162-00	80009	1	
	198-0902-00	80009	1	
-32	47439	22526	4	
-33	200-0616-00	80009	1	
-34	136-0202-01	80009	1	
-35	384-1351-00	80009	1	
-36	213-0153-00	80009	1	
-37	670-4853-00	80009	1	
-38	161-0118-00	80009	1	
-39	337-2388-00	80009	1	
-40	211-0207-00	80009	1	
-41	129-0123-00	80009	1	
-42	211-0016-00	80009	1	
-43	1104-00-00-0541C	78189	1	
-44	F-11935-6	02777	1	
-45	211-0016-00	80009	1	
-46	210-0586-00	80009	1	
-47	333-2273-00	80009	1	
-48	213-0113-00	80009	1	
-49	348-0434-00	80009	4	
-50	200-1802-05	80009	1	
-51	211-0511-00	80009	4	
-52	28JR166-1	24931	4	
-53	210-0255-00	80009	4	
-54	200-0103-00	80009	1	
-55	129-0077-00	80009	1	
-56	3089-402	73743	1	
-57	1214-05-00-0541C	78189	1	
-58	151-0349-00	80009	3	
-59	2X12161-402	73743	3	

AIR FORCE TO33A1-13-496-1
 NAVELEX 0969-LP-170-0010
 Main Chassis Assembly

FIG. & INDEX NO.	PART NUMBER	FSCM	DESCRIPTION							UNITS PER ASSY	USABLE ON CODE
			1	2	3	4	5	6	7		
8-13-60	4704-04-02	78189	.	WASHER, LOCK, 0.228 ID X 0.375 inch OD, steel..						3	
			(AP)	(80009 No. 210-1122-00)							
-61	342-0163-00	80009	.	INSULATOR, PLATE, transistor.....						3	
-62	214-2330-00	80009	.	HEAT SINK, TRANSISTOR.....						1	
-63	210-0457-00	80009	.	NUT, PLAIN, EXTENDED WASHER, 6-32 X 0.312 inch,						4	
			steel	(AP)							
-64	2104-04-00-2520N	78189	.	TERMINAL, LUG, SE #4 (80009 No. 210-0201-00)..						1	
-65	210-0586-00	80009	.	NUT, PLAIN, EXTENDED WASHER, 4-40 X 0.25 inch.,						1	
			steel	(AP)							
-66	2157-06-01-2520N	78189	.	TERMINAL, LUG, 0.146 inch diameter, 45 degree..						1	
			bend	(80009 No. 210-0204-00)							
-67	210-0586-00	80009	.	NUT, PLAIN, EXTENDED WASHER, 4-40 X 0.25 inch.,						1	
			steel	(AP)							
-68	260-1780-00	80009	.	SWITCH, SLIDE, DPDT, 3A, 125V.....						1	
-69	2X12161-402	73743	.	NUT, PLAIN, HEXAGON, 4-40 X 0.188 inch, brass...						2	
			(AP)	(80009 No. 210-0406-00)							
-70	1204-00-00-0541C	78189	.	WASHER, LOCK, internal, 0.12 ID X 0.26 inch OD,						2	
			steel	(AP) (80009 No. 210-0004-00)							
-71	200-0237-03	80009	.	COVER, FUSEHOLDER.....						1	
-72	AGC 1	71400	.	FUSE, CARTRIDGE, 3AG, 1A, 250V, fast-blow (80009.						1	
			No. 159-0022-00)								
-73	345002	75915	.	FUSEHOLDER, with hardware (80009 No.....						1	
			352-0362-01)								
-74	333-2274-00	80009	.	PANEL, REAR, fuse.....						1	
-75	120-1095-00	80009	.	TRANSFORMER, POWER, STEPDOWN.....						1	
-76	220-0410-00	80009	.	NUT, EXTENDED WASHER, 10-32 X 0.375 inch, steel						4	
			(AP)								
-77	212-0517-00	80009	.	SCREW, MACHINE, 10-32 X 1.750 inch, hex head,..						4	
			steel	(AP)							
-78	210-0812-00	80009	.	WASHER, NONMETAL, #10 fiber (AP).....						4	
-79	166-0226-00	80009	.	INSULATOR SLEEVE, ELECTRICAL, 1.125 inch long.						4	
			(AP)								
-80	220-1544-01	80009	.	COVER, TRANSFORMER, 2.5 X 3.0 X 0.65 inch high						1	
-81	386-3691-00	80009	.	SUBPANEL, REAR.....						1	
-82	179-2514-00	80009	.	WIRING HARNESS, power.....						1	
-83	42617-2	00779	.	CONTACT, ELECTRICAL, quick disconnect (80009						6	
			No. 131-0861-00)								
-84	1-480435-0	00779	.	COVER, ELECTRICAL CONNECTOR, plastic (80009.						6	
			No. 200-1075-00)								
	198-3418-00	80009	.	WIRE SET, ELECTRICAL, main module.....						1	
-85	46231	22526	.	CONTACT, ELECTRICAL, 0.577 inch long, 22-26..						12	
			AWG wire	(80009 No. 131-0621-00)							
-86	47439	22526	.	CONTACT, ELECTRICAL, 0.48 inch long, 22-26..						18	
			AWG wire	(80009 No. 131-0707-00)							
-87	08-56-0105	27264	.	CONTACT, ELECTRICAL, 18-24 AWG, female, brass.						9	
			(80009 No. 131-1790-00)								
-88	TEK-175-0832-00	23499	.	WIRE, ELECTRICAL, 9 wire ribbon, 0.917 foot..						AR	
			long	(80009 No. 175-0832-00)							
-89	175-0862-00	80009	.	WIRE, ELECTRICAL, 3 wire ribbon, 1.896 foot..						AR	
			long								

FIG. & INDEX NO.	PART NUMBER	FSCM	DESCRIPTION							UNITS PER ASSY	USABLE ON CODE
			1	2	3	4	5	6	7		
8-13-90	09-50-4031	27264	.	.	BODY,CONNECTOR,PLUG,3 female position,.... nylon (80009 No. 204-0671-00)					3	
-91	210-0774-00	80009	.	.	EYELET,METALLIC,0.152 OD X 0.245 inch..... long,brass					4	
-92	210-0775-00	80009	.	.	EYELET,METALLIC,0.126 OD X 0.230 inch..... long,brass					4	
-93	352-0167-00	80009	.	.	CONNECTOR BODY,PLUG,ELECTRICAL,9 wire..... black					2	
-94	352-0199-00	80009	.	.	CONNECTOR BODY,PLUG,ELECTRICAL,3 wire..... black					3	

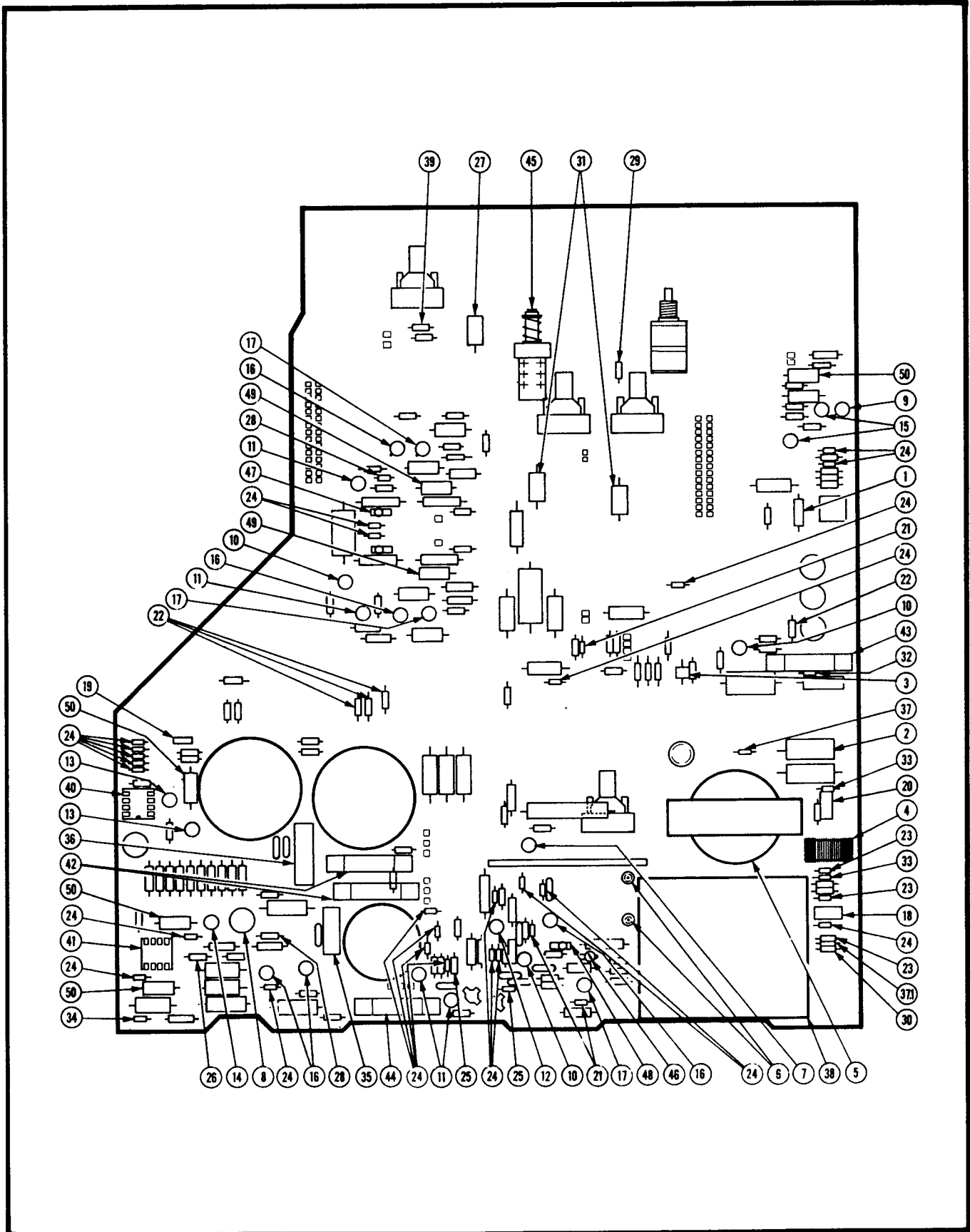

Figure 8-14. Circuit Board Assembly, Interface (Sheet 1 of 4).

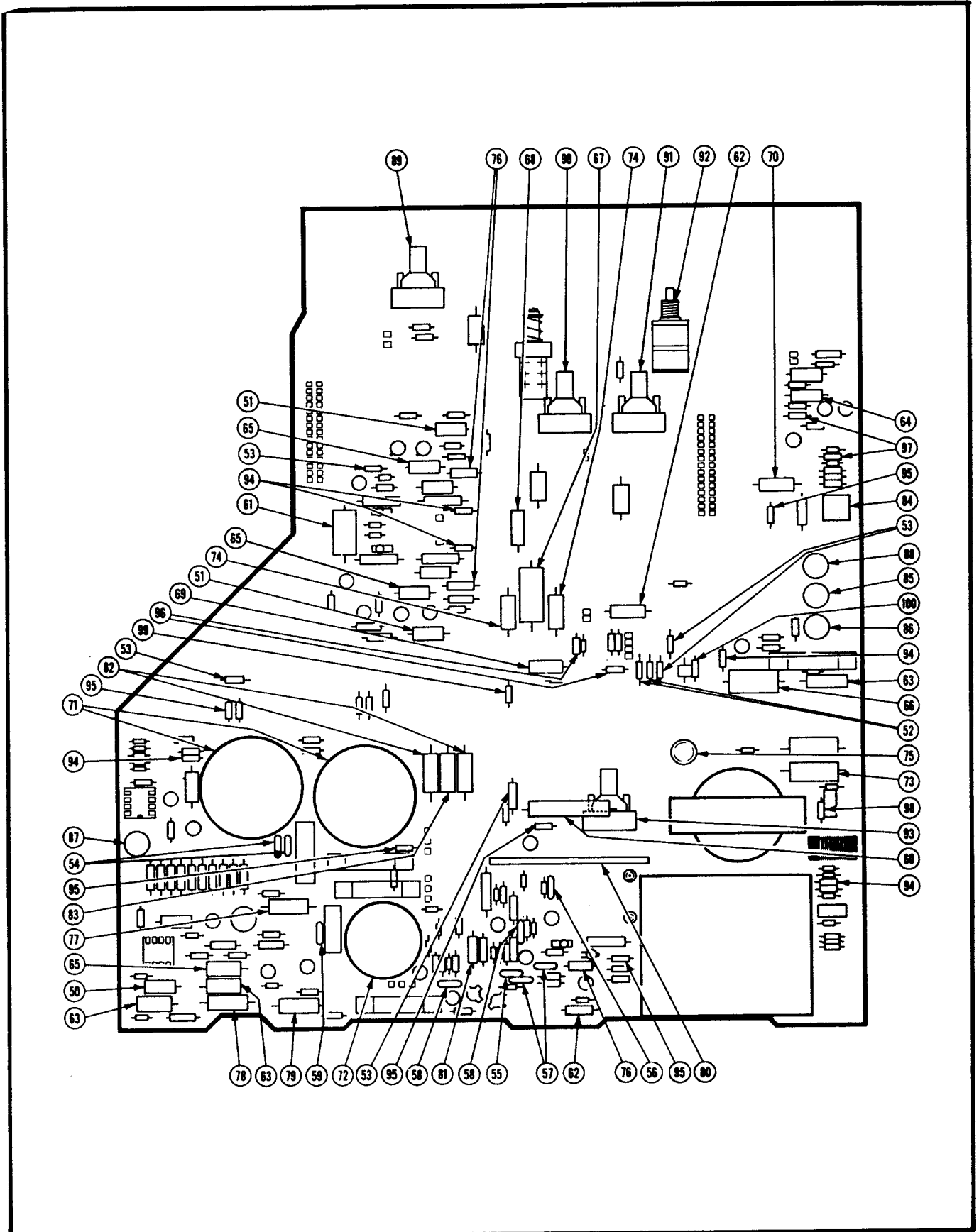

Figure 8-14. Circuit Board Assembly, Interface (Sheet 2 of 4).

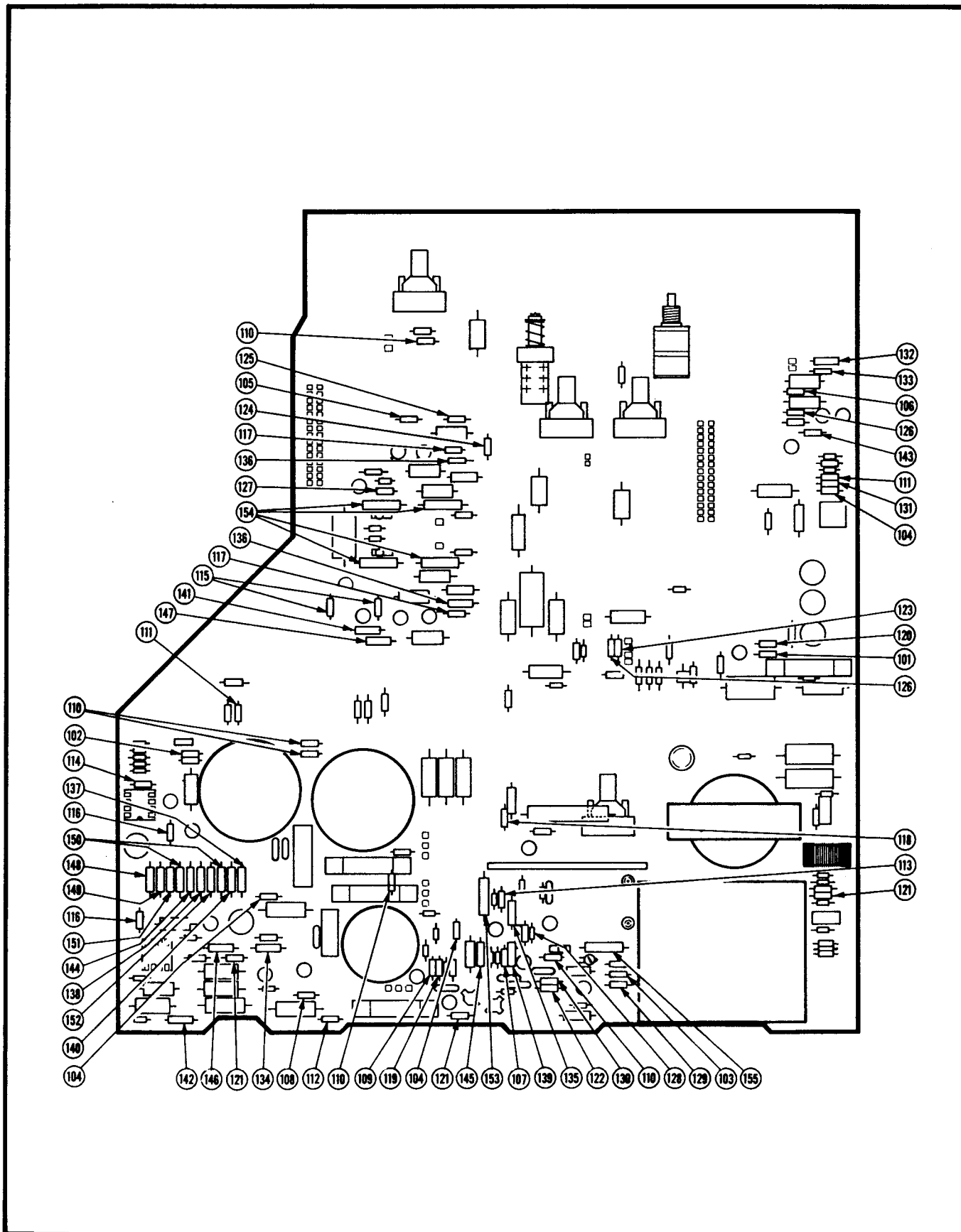

Figure 8-14. Circuit Board Assembly, Interface (Sheet 3 of 4).

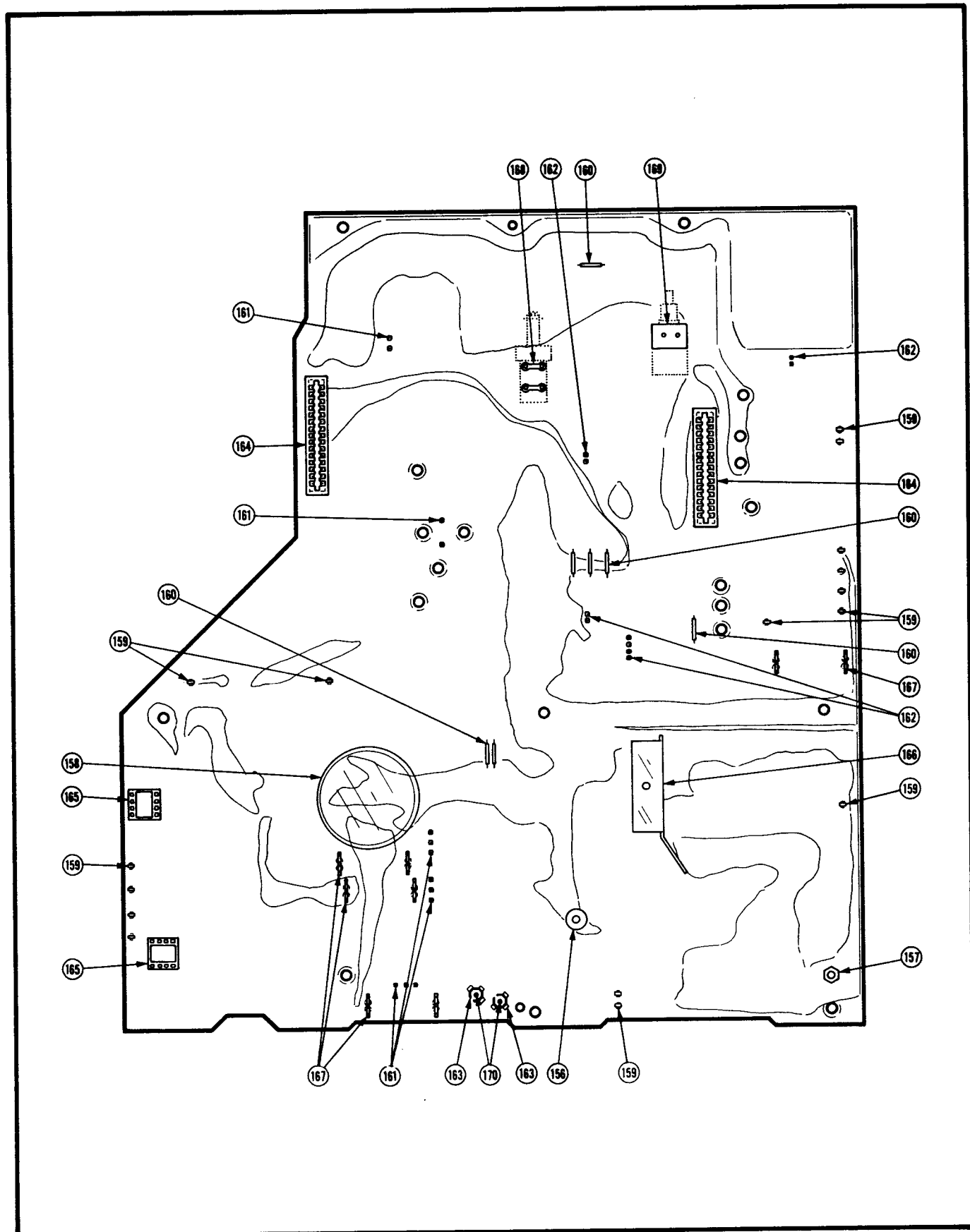

Figure 8-14. Circuit Board Assembly, Interface (Sheet 4 of 4).

AIR FORCE TO33A1-13-496-1
NAVELEX 0969-LP-170-0010
Circuit Board Assembly, Interface

FIG. & INDEX NO.	PART NUMBER	FSCM	DESCRIPTION							UNITS PER ASSY	USABLE ON CODE
			1	2	3	4	5	6	7		
8-14-	670-4853-00	80009	CIRCUIT BOARD ASSEMBLY, Interface, NHA Figure... 13-37							REF	
-1	108-0245-00	80009	. COIL, RADIO FREQUENCY, 3.9UH.....							1	
-2	108-0422-00	80009	. COIL, RADIO FREQUENCY, 80UH.....							1	
-3	70F183A1	76493	. COIL, RADIO FREQUENCY, 1.8MH (80009 No..... 108-0691-00)							1	
-4	108-0820-00	80009	. COIL, RADIO FREQUENCY, 72UH.....							1	
-5	120-0984-00	80009	. TRANSFORMER, POWER, STEP-DOWN AND STEP-UP, High Voltage							1	
-6	NE2T-A1AT	08806	. LAMP, GLOW, 0.5MA, 60/125V (80009 No..... 150-0002-00)							2	
-7	2N2484	15818	. TRANSISTOR, silicon, NPN (80009 No..... 151-0126-00)							1	
-8	35495	02735	. TRANSISTOR, silicon, NPN (80009 No..... 151-0136-00)							1	
-9	151-0164-00	80009	. TRANSISTOR, silicon, PNP.....							1	
-10	2N3906	01295	. TRANSISTOR, silicon, PNP (80009 No..... 151-0188-00)							3	
-11	151-0190-00	80009	. TRANSISTOR, silicon, NPN.....							4	
-12	151-0192-00	80009	. TRANSISTOR, silicon, NPN, selected.....							1	
-13	2N2907A	04713	. TRANSISTOR, silicon, PNP (80009 No..... 151-0301-00)							2	
-14	2N2222A	04713	. TRANSISTOR, silicon, NPN (80009 No..... 151-0302-00)							1	
-15	151-0342-00	80009	. TRANSISTOR, silicon, PNP.....							2	
-16	151-0347-00	80009	. TRANSISTOR, silicon, NPN.....							5	
-17	151-0350-00	80009	. TRANSISTOR, silicon, PNP.....							3	
-18	151-0364-00	80009	. TRANSISTOR, silicon, PNP.....							1	
-19	151-0405-00	80009	. TRANSISTOR, silicon, NPN, selected.....							1	
-20	151-0426-02	80009	. TRANSISTOR, silicon, NPN, selected.....							1	
-21	152-0061-00	80009	. SEMICONDUCTOR DEVICE, silicon, 175V, 100MA.....							3	
-22	152-0066-00	80009	. SEMICONDUCTOR DEVICE, silicon, 400V, 750MA.....							4	
-23	152-0107-04	80009	. SEMICONDUCTOR DEVICE, silicon, 400V, 400MA, selected							3	
-24	1N4152	07910	. SEMICONDUCTOR DEVICE, silicon, 30V, 150MA..... (80009 No. 152-0141-02)							24	
-25	152-0195-00	80009	. SEMICONDUCTOR DEVICE, zener, 0.4W, 5.1V, 5%.....							2	
-26	1N970B	04713	. SEMICONDUCTOR DEVICE, zener, 0.4W, 24V, 5%..... (80009 No. 152-0265-00)							1	
-27	1N3034B	04713	. SEMICONDUCTOR DEVICE, zener, 1W, 39V, 5%..... (80009 No. 152-0229-00)							1	
-28	1N965B	81483	. SEMICONDUCTOR DEVICE, zener, 0.4W, 15V, 5%..... (80009 No. 152-0243-00)							2	
-29	1N989B	04713	. SEMICONDUCTOR DEVICE, zener, 0.4W, 150V, 5%..... (80009 No. 152-0247-00)							1	
-30	1N991B	04713	. SEMICONDUCTOR DEVICE, zener, 0.4W, 180V, 5%..... (80009 No. 152-0289-00)							1	
-31	1N3828A	04713	. SEMICONDUCTOR DEVICE, 1W, 6.2V, 5% (80009 No... (80009 No. 152-0309-00)							2	
-32	1N983B	04713	. SEMICONDUCTOR DEVICE, zener, 0.4W, 82V, 5%..... (80009 No. 152-0357-00)							1	

FIG. & INDEX NO.	PART NUMBER	FSCM	DESCRIPTION							UNITS PER ASSY	USABLE ON CODE
			1	2	3	4	5	6	7		
8-14-33	1N4935	04713	.	S	S	S	S	S	S	2	
			.	S	S	S	S	S	S		
-34	1N937	04713	.	S	S	S	S	S	S	1	
			.	S	S	S	S	S	S		
-35	152-0488-00	80009	.	S	S	S	S	S	S	1	
			.	S	S	S	S	S	S		
-36	MDA960-1	04713	.	S	S	S	S	S	S	1	
			.	S	S	S	S	S	S		
-37	152-0629-00	80009	.	S	S	S	S	S	S	1	
			.	S	S	S	S	S	S		
-37.1	1N968B	04713	.	S	S	S	S	S	S	1	
			.	S	S	S	S	S	S		
-38	152-0635-00	80009	.	S	S	S	S	S	S	1	
			.	S	S	S	S	S	S		
-39	1N957B	04713	.	S	S	S	S	S	S	1	
			.	S	S	S	S	S	S		
-40	156-0067-00	80009	.	S	S	S	S	S	S	1	
			.	S	S	S	S	S	S		
-41	156-0158-00	80009	.	S	S	S	S	S	S	1	
			.	S	S	S	S	S	S		
-42	AGC 2	71400	.	S	S	S	S	S	S	2	
			.	S	S	S	S	S	S		
-43	AGC 1/4	71400	.	S	S	S	S	S	S	1	
			.	S	S	S	S	S	S		
-44	AGC 3/10	71400	.	S	S	S	S	S	S	1	
			.	S	S	S	S	S	S		
-45	7101-J61-CB22	09353	.	S	S	S	S	S	S	1	
			.	S	S	S	S	S	S		
-46	530-002	72982	.	S	S	S	S	S	S	1	
			.	S	S	S	S	S	S		
-47	2222-801-96138	80031	.	S	S	S	S	S	S	2	
			.	S	S	S	S	S	S		
-48	2222-801-96139	80031	.	S	S	S	S	S	S	1	
			.	S	S	S	S	S	S		
-49	314-009C0K229D	72982	.	S	S	S	S	S	S	2	
			.	S	S	S	S	S	S		
-50	314-022X5P101M	72982	.	S	S	S	S	S	S	4	
			.	S	S	S	S	S	S		
-51	314-022Z5U0222M	72982	.	S	S	S	S	S	S	2	
			.	S	S	S	S	S	S		
-52	8005H9AADW5R103K	72982	.	S	S	S	S	S	S	2	
			.	S	S	S	S	S	S		
-53	8005H9AABZ5U104M	72982	.	S	S	S	S	S	S	5	
			.	S	S	S	S	S	S		
-54	855-558Z5U-103Z	72982	.	S	S	S	S	S	S	2	
			.	S	S	S	S	S	S		
-55	273C20	56289	.	S	S	S	S	S	S	1	
			.	S	S	S	S	S	S		
-56	8131N039Z5U-104Z	72982	.	S	S	S	S	S	S	1	
			.	S	S	S	S	S	S		
-57	274C10	56289	.	S	S	S	S	S	S	2	
			.	S	S	S	S	S	S		

AIR FORCE TO33A1-13-496-1
 NAVELEX 0969-LP-170-0010
 Circuit Board Assembly, Interface

FIG. & INDEX NO.	PART NUMBER	FSCM	DESCRIPTION							UNITS PER ASSY	USABLE ON CODE
			1	2	3	4	5	6	7		
8-14-58	19C611	56289	.	CAPACITOR, FIXED, CERAMIC DIELECTRIC, 0.022UF, .						2	
				+80-20%, 25V (80009 No. 283-0080-00)							
-59	19C242B	56289	.	CAPACITOR, FIXED, CERAMIC DIELECTRIC, 0.005UF, .						1	
				+80-20%, 150V (80009 No. 283-0110-00)							
-60	430P522	56289	.	CAPACITOR, FIXED, PLASTIC, 0.0012UF, 10%, 4000V..						1	
				(80009 No. 285-1040-00)							
-61	192P2249R8	56289	.	CAPACITOR, FIXED, PLASTIC, 0.22UF, 10%, 80V.....						1	
				(80009 No. 285-1098-00)							
-62	332K06PP481	19396	.	CAPACITOR, FIXED, PLASTIC, 3300pF, 10%, 400V.....						2	
				(80009 No. 285-1095-00)							
-63	PT605C473M	19396	.	CAPACITOR, FIXED, PLASTIC, 0.047UF, 20%, 200V....						3	
				(80009 No. 285-1099-00)							
-64	223J02PT485	19396	.	CAPACITOR, FIXED, PLASTIC, 0.022UF, 5%, 200V.....						1	
				(80009 No. 285-1100-00)							
-65	223K02PT485	19396	.	CAPACITOR, FIXED, PLASTIC, 0.022UF, 10%, 200V....						3	
				(80009 No. 285-1101-00)							
-66	PP680C823K	19396	.	CAPACITOR, FIXED, PLASTIC, 0.082UF, 10%, 200V....						1	
				(80009 No. 285-1119-00)							
-67	30D506G050DD9	56289	.	CAPACITOR, FIXED, ELECTROLYTIC, 50UF, +75-10%, ..						1	
				50V (80009 No. 290-0117-00)							
-68	30D205F150BB9	56289	.	CAPACITOR, FIXED, ELECTROLYTIC, 2UF, +50-10%, ...						1	
				150V (80009 No. 290-0159-00)							
-69	30D105F150BA2	56289	.	CAPACITOR, FIXED, ELECTROLYTIC, 1UF, +50-10%, ...						1	
				150V (80009 No. 290-0164-00)							
-70	150D475X0035B2	56289	.	CAPACITOR, FIXED, ELECTROLYTIC, 4.7UF, 20%, 35V..						1	
				(80009 No. 290-0187-00)							
-71	290-0508-01	80009	.	CAPACITOR, FIXED, ELECTROLYTIC, 18,000UF,						2	
				+100-10%, 15V							
-72	20-36435	90201	.	CAPACITOR, FIXED, ELECTROLYTIC, 1000UF, +75-10%,						1	
				75V (80009 No. 290-0586-01)							
-73	T11C825M075AS	05397	.	CAPACITOR, FIXED, ELECTROLYTIC, 8.2UF, 20%, 75V..						1	
				(80009 No. 290-0716-00)							
-74	290-0746-00	80009	.	CAPACITOR, FIXED, ELECTROLYTIC, 47UF, +50-10%, ..						2	
				16V							
-75	502D227	56289	.	CAPACITOR, FIXED, ELECTROLYTIC, 2.2UF, +50-10%, .						1	
				160V (80009 No. 290-0758-00)							
-76	EB2235	01121	.	RESISTOR, FIXED, COMPOSITION, 22k ohm, 5%, 0.50W						3	
				(80009 No. 301-0223-00)							
-77	GB2425	01121	.	RESISTOR, FIXED, COMPOSITION, 2.4k ohm, 5%, 1W...						1	
				(80009 No. 303-0242-00)							
-78	GB3025	01121	.	RESISTOR, FIXED, COMPOSITION, 3k ohm, 5%, 1W.....						1	
				(80009 No. 303-0302-00)							
-79	GB4725	01121	.	RESISTOR, FIXED, COMPOSITION, 4.7k ohm, 5%, 1W...						1	
				(80009 No. 303-0472-00)							
-80	307-0471-00	80009	.	RESISTOR, NETWORK, FIXED FILM, high voltage....						1	
				divider							
-81	RS2B-B16000J	91637	.	RESISTOR, FIXED, WIRE WOUND, 1.6k ohm, 5%, 3W....						1	
				(80009 No. 308-0393-00)							
-82	BWH-R5100J	75042	.	RESISTOR, FIXED, WIRE WOUND, 0.51 ohm, 5%, 2W....						2	
				(80009 No. 308-0679-00)							

FIG. & INDEX NO.	PART NUMBER	FSCM	DESCRIPTION							UNITS PER ASSY	USABLE ON CODE
			1	2	3	4	5	6	7		
8-14-83	BWH-1R800J	75042	.	RESISTOR, FIXED, WIRE WOUND, 1.8 ohm, 5%, 2W....						1	
				(80009 No. 308-0703-00)							
-84	3386F-T04-251	32997	.	RESISTOR, VARIABLE, NONWIRE WOUND, 250 ohm, 10%,						1	
				0.50W (80009 No. 311-1223-00)							
-85	91A-20002M	73138	.	RESISTOR, VARIABLE, NONWIRE WOUND, 200k ohm, ...						1	
				20%, 0.50W (80009 No. 311-1554-00)							
-86	91A-25001M	73138	.	RESISTOR, VARIABLE, NONWIRE WOUND, 25k ohm, 20%,						1	
				0.50W (80009 No. 311-1557-00)							
-87	91A-25000M	73138	.	RESISTOR, VARIABLE, NONWIRE WOUND, 2.5k ohm, ...						1	
				20%, 0.50W (80009 No. 311-1561-00)							
-88	91A-20000M	73138	.	RESISTOR, VARIABLE, NONWIRE WOUND, 2k ohm, 20%,						1	
				0.50W (80009 No. 311-1562-00)							
-89	3859Z-X05-103F	80294	.	RESISTOR, VARIABLE, NONWIRE WOUND, 10k ohm, ...						1	
				10%, 2W (80009 No. 311-1725-00)							
-90	3859Z-X04-202A	80294	.	RESISTOR, VARIABLE, NONWIRE WOUND, 2k ohm, 10%,						1	
				2W (80009 No. 311-1726-00)							
-91	3858Z-B78-203A	80294	.	RESISTOR, VARIABLE, NONWIRE WOUND, 20k ohm, 10%,						1	
				2W (80009 No. 311-1727-00)							
-92	D388-CM40910	12697	.	RESISTOR, VARIABLE, NONWIRE WOUND, 2k ohm/2M...						1	
				ohm (80009 No. 311-1769-00)							
-93	3859Z-X52-505Z	32997	.	RESISTOR, VARIABLE, NONWIRE WOUND, 5M ohm, 20%,						1	
				2W (80009 No. 311-1790-00)							
-94	CB1015	01121	.	RESISTOR, FIXED, COMPOSITION, 100 ohm, 5%, 0.25W.						5	
				(80009 No. 315-0101-00)							
-95	CB1025	01121	.	RESISTOR, FIXED, COMPOSITION, 1k ohm, 5%, 0.25W..						5	
				(80009 No. 315-0102-00)							
-96	CB1045	01121	.	RESISTOR, FIXED, COMPOSITION, 100k ohm, 5%, 0.25W						2	
				(80009 No. 315-0104-00)							
-97	CB1145	01121	.	RESISTOR, FIXED, COMPOSITION, 110k ohm, 5%, 0.25W						2	
				(80009 No. 315-0114-00)							
-98	CB1205	01121	.	RESISTOR, FIXED, COMPOSITION, 12 ohm, 5%, 0.25W..						1	
				(80009 No. 315-0120-00)							
-99	CB1225	01121	.	RESISTOR, FIXED, COMPOSITION, 1.2k ohm, 5%, 0.25W						1	
				(80009 No. 315-0122-00)							
-100	CB1235	01121	.	RESISTOR, FIXED, COMPOSITION, 12k ohm, 5%, 0.25W.						1	
				(80009 No. 315-0123-00)							
-101	CB1315	01121	.	RESISTOR, FIXED, COMPOSITION, 130 OHM, 5%, 0.25W.						1	
				(80009 No. 315-0131-00)							
-102	CB1325	01121	.	RESISTOR, FIXED, COMPOSITION, 1.3k ohm, 5%, 0.25W						1	
				(80009 No. 315-0132-00)							
-103	CB1515	01121	.	RESISTOR, FIXED, COMPOSITION, 150 ohm, 5%, 0.25W.						1	
				(80009 No. 315-0151-00)							
-104	CB1535	01121	.	RESISTOR, FIXED, COMPOSITION, 15k ohm, 5%, 0.25W.						3	
				(80009 No. 315-0153-00)							
-105	CB1825	01121	.	RESISTOR, FIXED, COMPOSITION, 1.8k ohm, 5%, 0.25W						1	
				(80009 No. 315-0182-00)							
-106	CB1835	01121	.	RESISTOR, FIXED, COMPOSITION, 18k ohm, 5%, 0.25W.						1	
				(80009 No. 315-0183-00)							
-107	CB2015	01121	.	RESISTOR, FIXED, COMPOSITION, 200 ohm, 5%, 0.25W						1	
				(80009 No. 315-0201-00)							

AIR FORCE TO33A1-13-496-1
 NAVELEX 0969-LP-170-0010
 Circuit Board Assembly, Interface

FIG. & INDEX NO.	PART NUMBER	FSCM								UNITS PER ASSY	USABLE ON CODE	
			1	2	3	4	5	6	7			DESCRIPTION
8-14-108	CB2045	01121	.								1	
-109	CB2225	01121	.								1	
-110	CB2725	01121	.								5	
-111	CB2735	01121	.								2	
-112	CB3035	01121	.								1	
-113	CB3905	01121	.								1	
-114	CB3915	01121	.								1	
-115	CB4315	01121	.								2	
-116	CB4325	01121	.								2	
-117	CB4705	01121	.								2	
-118	CB4715	01121	.								1	
-119	CB4725	01121	.								1	
-120	CB4745	01121	.								1	
-121	CB5115	01121	.								3	
-122	CB5125	01121	.								1	
-123	CB5135	01121	.								1	
-124	CB5625	01121	.								1	
-125	CB5635	01121	.								1	
-126	CB6235	01121	.								2	
-127	CB6815	01121	.								1	
-128	CB8215	01121	.								1	
-129	CB8235	01121	.								1	
-130	CB9115	01121	.								1	
-131	CB9125	01121	.								1	
-132	MFF1816G187ROF	91637	.								1	

AIR FORCE TO33A1-13-496-1
 NAVEXLEX 0969-LP-170-0010
 Circuit Board Assembly, Interface

FIG. & INDEX NO.	PART NUMBER	FSCM								UNITS PER ASSY	USABLE ON CODE	
			1	2	3	4	5	6	7			DESCRIPTION
8-14-133	MFF1816G619ROF	91637	.								1	
-134	MFF1816G634ROF	91637	.								1	
-135	MFF1816G665ROF	91637	.								1	
-136	MFF1816G909ROF	91637	.								2	
-137	MFF1816G11300F	91637	.								1	
-138	MFF1816G30100F	91637	.								1	
-139	MFF1816G42200F	91637	.								1	
-140	MFF1816G52300F	91637	.								1	
-141	MFF1816G54900F	91637	.								1	
-142	MFF1816G11801F	91637	.								1	
-143	MFF1816G16901F	91637	.								1	
-144	MFF1816G21001F	91637	.								1	
-145	MFF1816G24901F	91637	.								1	
-146	MFF1816G31601F	91637	.								1	
-147	MFF1816G47501F	91637	.								1	
-148	MFF1816D15001D	91637	.								1	
-149	MFF1816D40201D	91637	.								1	
-150	MFF1816D50000C	91637	.								2	
-151	MFF1816D32001C	91637	.								1	
-152	MFF1816D27001C	91637	.								1	
-153	CECTO-4871F	75042	.								1	
-154	CECTO-8871F	75042	.								4	
-155	CECTO-2212F	75042	.								1	
-156	129-0178-00	80009	.								1	
	211-0207-00	80009	.								1	

AIR FORCE TO33A1-13-496-1
 NAVELEX 0969-LP-170-0010
 Circuit Board Assembly, Interface

FIG. & INDEX NO.	PART NUMBER	FSCM	DESCRIPTION							UNITS PER ASSY	USABLE ON CODE
			1	2	3	4	5	6	7		
8-14-157	129-0230-00	80009	.	SPACER,POST,1.375	inch	long,with	4-40.....			1	
	211-0207-00	80009	.	SCREW,ASSEMBLED	WASHER,4-40	X	0.312	inch,...		1	
-158	200-0258-00	80009	.	SHIELD,CAPACITOR,	plastic.....					1	
-159	214-0579-00	80009	.	TERMINAL,TEST	POINT,0.40	inch	long.....			17	
-160	131-0566-00	80009	.	LINK,TERMINAL,	CONNECTOR,0.086	OD	X	2.375....		7	
				inch	long						
-161	47350	22526	.	CONTACT,ELECTRICAL,	0.46	inch	long	(80009....		13	
				No.	131-0589-00)						
-162	47357	22526	.	CONTACT,ELECTRICAL,	0.365	inch	long	(80009...)		10	
				No.	131-0608-00)						
-163	131-1003-00	80009	.	CONNECTOR,BODY,	circuit	board	mount,3	prong..		2	
-164	000-201-4986	05574	.	CONNECTOR,RECEPTACLE,	circuit	board,15/30,...				2	
				female	(80009	No.	131-2063-00)				
-165	C930802	01295	.	SOCKET,PLUG-IN,	microcircuit,8	contact.....				2	
				(80009	No.	136-0514-00)					
-166	337-2172-00	80009	.	SHIELD,ELECTRICAL,	high	voltage.....				1	
-167	344-0154-00	80009	.	CLIP,ELECTRICAL,	for	0.25	inch	diameter	fuse.	8	
-168	361-0608-00	80009	.	SPACER,PUSH	SWITCH,plastic.....					2	
-169	361-0761-00	80009	.	SPACER,VARIABLE	RESISTOR,plastic.....					1	
-170	75060	22526	.	SOCKET,PIN	TERMINAL,0.188	inch	long.....			2	
				(80009	No.	136-0252-04)					

SECTION IX ILLUSTRATED PARTS BREAKDOWN NUMERICAL INDEX

PART NUMBER	FIG. & INDEX NO.	QTY PER ART.	SMR CODE
AGC1/2	8-2-35	1	
AGC1/2	-14-43	1	
AGC 1	-13-72	1	
AGC 2	-14-42	2	
AGC 3/10	-14-44	1	
BB1005	-5-87	2	
BB1055	-6-11	2	
BB1055	-6-27		
BB1215	-5-88	2	
BB1225	-5-89	2	
BB2025	-5-90	2	
BB3005	-6-28	1	
BB4715	-5-91	1	
BB5625	-5-92	1	
BWH-R5100J	-14-82	2	
BWH-1R800J	-14-83	1	
CB-83314-CE	-2-31	2	
CB1005	-5-52	6	
CB1005	-8-25		
CB1015	-5-53	13	
CB1015	-8-26		
CB1015	-11-32		
CB1015	-14-94		
CB1025	-5-54	13	
CB1025	-8-27		
CB1025	-11-33		
CB1025	-14-95		
CB1035	-5-55	9	
CB1035	-8-28		
CB1035	-11-34		

PART NUMBER	FIG. & INDEX NO.	QTY PER ART.	SMR CODE
CB1045	8-11-35	3	
CB1045	-14-96		
CB1055	-8-29	4	
CB1055	-10-21		
CB1125	-10-22	2	
CB1125	-11-36		
CB1135	-11-37	1	
CB1145	-14-97	2	
CB1205	-14-98	1	
CB1215	-5-56	5	
CB1215	-6-25		
CB1215	-11-38		
CB1225	-11-39	3	
CB1225	-14-99		
CB1235	-11-40	3	
CB1235	-14-100		
CB1315	-5-57	3	
CB1315	-6-9		
CB1315	-14-101		
CB1325	-5-58	7	
CB1325	-8-30		
CB1325	-11-41		
CB1325	-14-102		
CB1335	-5-59	2	
CB1335	-9-4		
CB1515	-5-60	4	
CB1515	-14-103		
CB1525	-8-32	2	
CB1525	-11-42		

AIR FORCE TO33A1-13-496-1
 NAVELEX 0969-LP-170-0010
 Numerical Index

PART NUMBER	FIG. & INDEX NO.	QTY PER ART.	SMR CODE
CB1535	8 -8-33	5	
CB1535	-11-43		
CB1535	-14-104		
CB1545	-8-34	1	
CB1825	-5-61	5	
CB1825	-11-44		
CB1825	-14-105		
CB1835	-10-23	4	
CB1835	-11-45		
CB1835	-14-106		
CB2005	-5-62	7	
CB2005	-11-46		
CB2015	-5-63	3	
CB2015	-11-47		
CB2015	-14-107		
CB2025	-5-64	4	
CB2025	-8-35		
CB2035	-11-48	2	
CB2045	-8-36	2	
CB2045	-14-108		
CB2205	-8-37	2	
CB2215	-11-49	2	
CB2225	-8-38	10	
CB2225	-11-50		
CB2225	-14-109		
CB2235	-5-67	8	
CB2235	-8-39		
CB2235	-9-5		
CB2235	-10-25		
CB2235	-11-51		
CB2245	-9-6	1	
CB2255	-9-9	1	
CB2405	-5-65	2	
CB2415	-5-66	3	
CB2705	-7-22	4	
CB2705	-10-24		
CB2715	-8-40	2	
CB2725	-11-52	8	
CB2725	-14-110		
CB2735	-14-111	2	
CB3015	-5-68	4	
CB3015	-11-53		
CB3025	-8-41	2	
CB3035	-11-54	4	
CB3035	-14-112		
CB3305	-5-69	3	
CB3305	-11-55		
CB3315	-11-56	1	
CB3325	-5-70	10	
CB3325	-11-57		
CB3335	-8-42	1	

PART NUMBER	FIG. & INDEX NO.	QTY PER ART.	SMR CODE
CB3355	8 -8-43	2	
CB3355	-10-26		
CB3615	-5-71	1	
CB3625	-5-72	4	
CB3625	-8-44		
CB3625	-11-58		
CB3905	-8-45	2	
CB3905	-14-113		
CB3915	-9-7	5	
CB3915	-9-19		
CB3915	-11-59		
CB3915	-14-114		
CB3935	-9-8	1	
CB4305	-5-73	3	
CB4315	-5-74	5	
CB4315	-14-115		
CB4325	-14-116	2	
CB47G5	-5-40	5	
CB47G5	-10-13		
CB47G5	-11-29		
CB4705	-5-75	12	
CB4705	-8-46		
CB4705	-10-27		
CB4705	-11-60		
CB4705	-14-117		
CB4715	-5-76	5	
CB4715	-11-61		
CB4715	-14-118		
CB4725	-11-62	8	
CB4725	-14-119		
CB4735	-8-47	18	
CB4735	-11-63		
CB4745	-5-77	4	
CB4745	-11-64		
CB4745	-14-120		
CB4755	-11-65	1	
CB51G5	-8-22	2	
CB5105	-4-17	4	
CB5105	-6-10		
CB5105	-6-26		
CB5115	-5-78	4	
CB5115	-14-121		
CB5125	-5-79	2	
CB5125	-14-122		
CB5135	-14-123	1	
CB5145	-8-48	2	
CB5145	-10-29		
CB5605	-4-72	8	
CB5605	-5-80		
CB5605	-11-66		
CB5615	-8-49	2	

PART NUMBER	FIG. & INDEX NO.	QTY PER ART.	SMR CODE
CB5625	8 -5-81	2	
CB5625	-14-124		
CB5635	-11-67	2	
CB5635	-14-125		
CB5645	-11-68	1	
CB6205	-5-82	4	
CB6205	-8-50		
CB6215	-5-83	4	
CB6215	-8-51		
CB6225	-11-69	2	
CB6235	-5-84	3	
CB6235	-15-126		
CB6815	-4-71	10	
CB6815	-5-85		
CB6815	-8-52		
CB6815	-10-28		
CB6815	-11-70		
CB6815	-14-127		
CB6845	-11-71	1	
CB7505	-8-31	5	
CB7505	-8-53		
CB7525	-10-30	2	
CB7525	-11-72		
CB8205	-5-86	3	
CB8205	-10-31		
CB8215	-11-73	2	
CB8215	-14-128		
CB8225	-11-74	2	
CB8235	-14-129	1	
CB9105	-11-75	2	
CB9115	-10-32	2	
CB9115	-14-130	1	
CB9125	-14-131		
CB9135	-8-54	3	
CB9135	-9-10		
CB9135	-10-33		
CD12676	-5-16	4	
CD12676	-8-6		
CECTO-2212F	-14-155	1	
CECTO-4871F	-14-153	1	
CECTO-8871F	-14-154	4	
C191	-13-7	2	
C191	-13-14		
C40A820J	-11-21	2	
C930802	-8-58	4	
C930802	-11-88		
C930802	-14-165		
C931602	-10-39	4	
C931602	-11-87		
C932002	-8-59	2	

PART NUMBER	FIG. & INDEX NO.	QTY PER ART.	SMR CODE
D151E111F0	8 -5-37	1	
D155F201F0	-10-12	1	
D388-CM40910	-14-92	1	
EB2235	-14-76	3	
F-11935-6	-13-44	1	
FTSM19L1	-5-133	2	
GB2425	-14-77	1	
GB3025	-14-78	1	
GB4725	-14-79	1	
HMF188D22503B	-9-15	2	
HMF188D22503B	-9-24		
J-64281	-5-138	8	
J-64281	-11-91		
MDA960-1	-14-36	1	
MFF1816D15001D	-14-148	1	
MFF1816D27001C	-14-152	1	
MFF1816D32001C	-14-151	1	
MFF1816D37501B	-9-13	4	
MFF1816D37501B	-9-22		
MFF1816D37502B	-9-14	4	
MFF1816D37502B	-9-23		
MFF1816D400ROC	-5-120	2	
MFF1816D40201D	-14-149	1	
MFF1816D50000C	-14-150	2	
MFF1816D75001B	-9-11	2	
MFF1816D75001B	-9-20		
MFF1816D75002B	-9-12	2	
MFF1816D75002B	-9-21		
MFF1816G10R20F	-5-93	1	
MFF1816G10003F	-5-119	2	
MFF1816G110ROF	-5-105	2	
MFF1816G11000F	-5-117	1	
MFF1816G11300F	-14-137	1	
MFF1816G11501F	-10-36	2	
MFF1816G11801F	-14-142	1	
MFF1816G12R70F	-5-94	1	
MFF1816G130ROF	-5-108	2	
MFF1816G130ROF	-10-34		
MFF1816G133ROF	-5-106	2	
MFF1816G133R3D	-6-14	2	
MFF1816G133R3D	-6-31		
MFF1816G150ROD	-6-12	4	
MFF1816G150ROD	-6-29		
MFF1816G150ROF	-5-107	1	
MFF1816G15000F	-8-56	10	
MFF1816G16900F	-10-35	1	
MFF1816G16901F	-14-143	1	
MFF1816G174ROF	-5-109	1	
MFF1816G187ROF	-14-132	1	
MFF1816G200ROD	-6-13	4	

AIR FORCE TO33A1-13-496-1
 NAVELEX 0969-LP-170-0010
 Numerical Index

PART NUMBER	FIG. & INDEX NO.	QTY PER ART.	SMR CODE
MFF1816G200ROD	8 -6-30		
MFF1816G21001F	-14-144	1	
MFF1816G22100F	-11-76	1	
MFF1816G23700F	-11-77	1	
MFF1816G24901F	-14-145	1	
MFF1816G26101F	-10-37	1	
MFF1816G26700F	-8-55	12	
MFF1816G287ROF	-5-110	4	
MFF1816G294ROF	-5-111	2	
MFF1816G30R10F	-5-95	2	
MFF1816G30100F	-14-138	1	
MFF1816G31601F	-14-146	1	
MFF1816G324ROF	-5-112	2	
MFF1816G332ROF	-5-113	2	
MFF1816G33200F	-11-78	1	
MFF1816G35702F	-5-118	1	
MFF1816G38R30F	-5-96	1	
MFF1816G39R20F	-5-97	1	
MFF1816G392ROF	-5-114	3	
MFF1816G41R20F	-5-98	1	
MFF1816G412ROF	-5-115	2	
MFF1816G42200F	-14-139	1	
MFF1816G45300F	-11-79	1	
MFF1816G47501F	-14-147	1	
MFF1816G49R90F	-5-99	3	
MFF1816G511R0F	-5-116	1	
MFF1816G52300F	-14-140	1	
MFF1816G54900F	-14-141	1	
MFF1816G56200F	-11-80	1	
MFF1816G60R40F	-5-100	2	
MFF1816G619ROF	-14-133	1	
MFF1816G634ROF	-14-134	1	
MFF1816G66R50F	-5-101	2	
MFF1816G665ROF	-14-135	1	
MFF1816G75R00F	-5-102	2	
MFF1816G80R60F	-5-103	2	
MFF1816G800ROD	-6-15	2	
MFF1816G800ROD	-6-32		
MFF1816G84501F	-11-81	1	
MFF1816G909ROF	-14-136	2	
MFF1816G93R10F	-5-104	1	
NE2T-ALAT	-14-6	2	
NS2BB430ROF	-5-43	2	
PP680C823K	-14-66	1	
PT605C473M	-11-22	4	
PT605C473M	-14-63		
RS2B-B16000J	-14-81	1	
SF93007	-5-14	2	
S039650	-5-11	1	

PART NUMBER	FIG. & INDEX NO.	QTY PER ART.	SMR CODE
S6075	8 -5-7	1	
TEK-175-0827-00	-7-69	AR	
TEK-175-0828-00	-7-56	AR	
TEK-175-0829-00	-4-102	AR	
TEK-175-0829-00	-7-70		
TEK-175-0832-00	-13-88	AR	
T11C825M075AS	-14-73	1	
T4-34M	-4-37	3	
UG274BUDURAPLATE	-2-2	1	
OSL-16L-100	-7-18	1	
000-201-4986	-14-164	2	
010-6101-00	-2-6	1	
010-6104-00	-2-14	2	
013-0107-03	-2-19	3	
020-0233-00	-2-6	1	
08-56-0105	-13-87	9	
09-50-4031	-13-90	3	
1-380949-6	-9-16	4	
1-380949-6	-9-25		
1-380949-6	-10-40		
1-380949-8	-9-17	3	
1-380949-8	-10-41		
1-380949-9	-10-42	2	
1-480435-0	-13-84	6	
1DE104-K-220EC	-5-42	1	
1N3034B	-14-27	1	
1N3828A	-14-31	2	
1N4152	-5-15	89	
1N4152	-8-5		
1N4152	-11-6		
1N4152	-14-24		
1N4935	-14-33	2	
1N937	-14-34	1	
1N957B	-14-39	1	
1N965B	-14-28	2	
1N968B	-14-37	1	
1N970B	-14-26	1	
1N983B	-14-32	1	
1N989B	-14-29	1	
1N991B	-14-30	1	
103-0051-01	-2-17	3	
103-0186-01	-7-28	3	
103-0186-02	-4-26	2	
103-0186-02	-7-24		
105-0420-00	-5-121	1	
105-0421-00	-5-120	1	
105-0422-00	-5-128	1	
105-0423-00	-5-123	1	

PART NUMBER	FIG. & INDEX NO.	QTY PER ART.	SMR CODE
105-0677-00	8 -3-16	6	
105-0737-00	-4-80	2	
105-0738-00	-4-85	2	
105-0739-00	-3-3	2	
108-0245-00	-14-1	1	
108-0262-00	-5-1	2	
108-0328-00	-5-5	2	
108-0422-00	-14-2	1	
108-0570-00	-5-3	2	
108-0724-00	-11-1	1	
108-753-17	-2-15	3	
108-0818-00	-12-31	1	
108-0819-00	-12-34	1	
108-0820-00	-14-4	1	
1104-00-00-0541C	-12-41	2	
1104-00-00-0541C	-13-43		
119-0860-00	-4-33	1	
120-0384-00	-5-6	1	
120-0984-00	-14-5	1	
120-1094-00	-5-4	2	
120-1095-00	-13-75	1	
1204-00-00-0541C	-13-21	3	
1204-00-00-0541C	-13-70		
1214-05-00-0541C	-4-93	6	
1214-05-00-0541C	-4-98		
1214-05-00-0541C	-7-54		
1214-05-00-0541C	-13-57		
129-0077-00	-13-55	1	
129-0123-00	-13-41	1	
129-0178-00	-14-156	1	
129-0230-00	-14-157	1	
129-0308-00	-12-39	1	
129-0575-00	-4-38	2	
129-0575-00	-7-63		
1296	-2-4	1	
131-0472-00	-12-45	4	
131-0566-00	-5-135	12	
131-0566-00	-10-38		
131-0566-00	-11-82		
131-0566-00	-14-160		
131-1003-00	-5-132	4	
131-1003-00	-11-85		
131-1003-00	-14-163		
131-1030-00	-5-130	6	
131-1031-00	-5-131	7	
131-1758-05	-4-89	2	
131-1758-06	-4-89	2	
131-1978-00	-6-1	4	
131-1978-00	-6-16		

PART NUMBER	FIG. & INDEX NO.	QTY PER ART.	SMR CODE
131-1979-00	8 -6-2	10	
131-1979-00	-6-17		
131-2028-00	-4-63	4	
136-0202-01	-13-34	1	
136-0624-00	-13-30	1	
150-1001-02	-4-12	5	
150-1001-02	-7-17		
150D106X0015B2	-11-24	1	
150D475X0035B2	-14-70	1	
150D564X0100A2	-11-27	1	
151-0164-00	-14-9	1	
151-0190-00	-5-8	17	
151-0190-00	-8-2		
151-0190-00	-11-4		
151-0190-00	-14-11		
151-0192-00	-14-12	1	
151-0342-00	-14-15	2	
151-0347-00	-14-16	5	
151-0349-00	-13-58	3	
151-0350-00	-14-17	3	
151-0364-00	-14-18	1	
151-0405-00	-14-19	1	
151-0426-02	-14-20	1	
151-0434-00	-5-9	4	
151-0446-00	-4-40	2	
151-0447-00	-5-10	2	
151-0472-00	-5-13	7	
151-0472-00	-8-3		
151-1042-00	-8-4	4	
151-1042-00	-11-5		
152-0061-00	-14-21	3	
152-0066-00	-14-22	4	
152-0107-04	-14-23	3	
152-0195-00	-14-25	2	
152-0217-00	-9-1	1	
152-0269-00	-5-17	2	
152-0488-00	-14-35	1	
152-0629-00	-14-37	1	
152-0635-00	-14-38	1	
154-0777-00	-12-15	1	
155-0122-00	-11-7	1	
155-0123-00	-11-8	2	
155-0124-00	-10-2	1	
155-0151-00	-8-7	2	
155-0155-00	-5-18	1	
156-0067-00	-8-8	2	
156-0067-00	-14-40		
156-0158-00	-11-9	2	
156-0158-00	-14-41		
161-0118-00	-13-38	1	

AIR FORCE TO33A1-13-496-1
 NAVELEX 0969-LP-170-0010
 Numerical Index

PART NUMBER	FIG. & INDEX NO.	QTY PER ART.	SMR CODE
162D105X0035CD2	8-11-25	1	
162D225X0020CD2	-11-23	6	
162D274X9035BC2	-11-26	1	
162D275X9015CD2	-5-39	2	
166-0226-00	-13-79	4	
175-0124-01	-2-20	3	
175-0825-00	-4-106	AR	
175-0825-00	-7-67		
175-0825-00	-12-51		
175-0826-00	-7-68	AR	
175-0862-00	-13-89	AR	
175-1661-00	-2-9	2	
175-1661-00	-2-13		
179-2514-00	-13-82	1	
19C242B	-14-59	1	
19C611	-14-58	2	
192P2249R8	-14-61	1	
198-0902-00	-13-31	1	
198-2581-00	-4-99	2	
198-3068-00	-7-55	1	
198-3416-00	-4-103	1	
198-3417-00	-7-65	1	
198-3418-00	-13-84	1	
2DM301	-13-3	1	
2D1596	-5-41	1	
2KAB010000	-10-4	1	
2N2222A	-14-14	1	
2N2484	-14-7	1	
2N2907A	-14-12	2	
2N3906	-8-1	16	
2N3906	-10-1		
2N3906	-11-3		
2N3906	-14-10		
2N3947	-5-12	1	
2X12161-402	-4-47	34	
2X12161-402	-4-56		
2X12161-402	-4-74		
2X12161-402	-4-79		
2X12161-402	-4-83		
2X12161-402	-4-88		
2X12161-402	-7-36		
2X12161-402	-7-44		
2X12161-402	-13-59		
2X12161-402	-13-69		
2X20224-402	-4-92	5	
2X20224-402	-4-97		
2X20224-402	-7-53		

PART NUMBER	FIG. & INDEX NO.	QTY PER ART.	SMR CODE
20-36435	8-14-72	1	
200-0103-00	-13-54	1	
200-0237-03	-13-71	1	
200-0258-00	-14-158	1	
200-0602-00	-3-6	2	
200-0616-00	-13-33	1	
200-1544-01	-13-80	1	
200-1802-05	-13-50	1	
200-2052-00	-4-20	2	
200-2055-00	-2-34	1	
200-2055-01	-2-20	1	
200-2056-00	-2-25	1	
206-0105-00	-2-16	3	
206-0191-01	-2-8	2	
206-0191-01	-2-12		
206-0223-00	-2-7	1	
206-0224-00	-2-11	1	
206-0244-00	-2-14	1	
20704-L67-322	-13-15	1	
21-13900	-3-1	AR	
210-0054-00	-7-43	4	
210-0056-00	-3-13	2	
210-0255-00	-7-31	5	
210-0255-00	-13-53		
210-0457-00	-4-39	11	
210-0457-00	-4-51		
210-0457-00	-7-64		
210-0457-00	-13-11		
210-0457-00	-13-13		
210-0457-00	-13-63		
210-0551-00	-8-62	2	
210-0586-00	-4-16	9	
210-0586-00	-12-30		
210-0586-00	-13-6		
210-0586-00	-13-25		
210-0586-00	-13-46		
210-0586-00	-13-65		
210-0586-00	-13-67		
210-0599-00	-4-43	4	
210-0622-00	-2-27	2	
210-0627-00	-4-41	2	
210-0761-00	-3-4	2	
210-0774-00	-13-91	4	
210-0775-00	-13-92	4	
210-0805-00	-3-14	2	
210-0812-00	-13-78	4	
210-0994-00	-3-5	7	

PART NUMBER	FIG. & INDEX NO.	QTY PER ART.	SMR CODE
210-0994-00	8 -7-42		
210-0994-00	-12-26		
210-1105-00	-2-24		
210-3067-00	-2-32	4	
210-3068-00	-2-29	6	
210-3068-00	-2-32		
2104-04-00-2520N	-13-64	1	
2104-06-00-2520N	-13-17	1	
211-0001-00	-12-17	2	
211-0007-00	-4-23	5	
211-0007-00	-12-29		
211-0007-00	-13-28		
211-0008-00	-4-16	14	
211-0008-00	-4-21		
211-0008-00	-4-57		
211-0008-00	-4-73		
211-0012-00	-4-32	9	
211-0012-00	-4-46		
211-0012-00	-7-35		
211-0012-00	-13-20		
211-0016-00	-13-42	2	
211-0016-00	-13-45		
211-0019-00	-7-41	4	
211-0097-00	-4-22	6	
211-0097-00	-4-55		
211-0097-00	-7-35		
211-0097-00	-13-5		
211-0116-00	-4-78	13	
211-0116-00	-4-82		
211-0116-00	-4-87		
211-0116-00	-12-40		
211-0121-00	-4-61	6	
211-0121-00	-4-62		
211-0143-00	-1-10	1	
211-0207-00	-13-40	3	
211-0207-00	-14-156		
211-0207-00	-14-157		
211-0240-00	-8-61	2	
211-0503-00	-1-4	4	
211-0503-00	-1-6		
211-0504-00	-1-13	6	
211-0504-00	-13-18		
211-0507-00	-4-50	2	
211-0510-00	-4-35	1	
211-0511-00	-13-51	4	
211-0516-00	-1-8	4	
211-0534-00	-1-12	12	
211-0534-00	-12-25		
211-0534-00	-13-10		
211-0534-00	-13-24		

PART NUMBER	FIG. & INDEX NO.	QTY PER ART.	SMR CODE
2112D	8-12-18	2	
212-0517-00	-13-77	4	
212-0623-00	-3-12	2	
213-0004-00	-7-10	1	
213-0048-00	-5-125	1	
213-0075-00	-4-29	9	
213-0075-00	-4-95		
213-0075-00	-7-51		
213-0113-00	-4-10	4	
213-0113-00	-7-16		
213-0113-00	-13-48		
213-0124-00	-13-16	2	
213-0138-00	-7-62	1	
213-0146-00	-4-53	9	
213-0146-00	-7-33		
213-0146-00	-7-58		
213-0146-00	-7-61		
213-0153-00	-4-2	4	
213-0153-00	-7-6		
213-0153-00	-13-36		
213-0183-00	-4-34	6	
213-0183-00	-12-21		
213-0227-00	-3-9	4	
213-0243-00	-7-8	2	
213-0313-00	-12-13	4	
214-0368-00	-4-44	2	
214-0515-02	-3-11	2	
214-0516-00	-3-10	2	
214-0579-00	-5-137	27	
214-0579-00	-10-43		
214-0579-00	-11-89		
214-0579-00	-14-159		
214-1126-01	-4-75	6	
214-1126-01	-5-126		
214-1126-02	-8-63	4	
214-1127-00	-5-127	6	
214-1127-00	-8-64		
214-1138-00	-4-48	2	
214-1139-02	-7-47	4	
214-1752-00	-4-76	4	
214-1779-00	-5-122	1	
214-1987-00	-3-15	2	
214-2270-00	-3-20	2	
214-2270-00	-12-28		
214-2292-04	-8-9	2	
214-2294-02	-8-10	2	
214-2329-00	-4-13	2	

Numerical Index

PART NUMBER	FIG. & INDEX NO.	QTY PER ART.	SMR CODE
214-2329-00	8 -7-20		
214-2330-00	-13-62	1	
214-2519-00	-4-58	2	
214-2521-00	-3-21	1	
2157-06-01-2520N	-13-66	1	
220-0410-00	-13-76	4	
220-0419-00	-1-9	4	
220-0455-00	-4-73	4	
2222-801-96138	-4-59	4	
2222-801-96138	-14-47		
2222-801-96139	-14-48	1	
223J02PT485	-14-64	1	
223K02PT485	-8-20	1	
223K02PT485	-14-65	3	
260-1211-00	-8-11	1	
260-1424-01	-5-19	1	
260-1445-01	-5-20	1	
260-1453-00	-10-3	1	
260-1720-00	-11-11	1	
260-1780-00	-13-68	1	
260-1802-00	-11-10	1	
263-1110-00	-7-46	1	
273C20	-5-33	2	
273C20	-14-55		
274C10	-14-57	2	
28JRL66-1	-7-30	6	
28JRL66-1	-13-52		
28PR224-1	-2-10	1	
281-0205-00	-5-21		
285-0753-00*	-7-37	2	
285-0782-00*	-7-38	2	
285-1060-01*	-7-39	1	
285-1132-00	-4-18	2	
29-JP116-1	-2-3	2	
290-0508-01	-14-71	2	
290-0746-00	-11-28	4	
290-0746-00	-14-74		
290-0776-00	-8-21	4	
295-0177-00	-7-36	1	
30D105F150BA2	-14-69	1	
30D205F150BB9	-14-68	1	
30D506G050DD9	-14-67	1	
301-000C0G0240J	-6-19	1	
301-000C0H0759D	-6-22	1	
301-000C0J0229C	-6-6	1	
301-000C0J0279C	-6-21	1	
301-000C0J0339C	-4-67	2	
301-000C0J0399C	-6-5	1	

PART NUMBER	FIG. & INDEX NO.	QTY PER ART.	SMR CODE
301-000C0K0189B	8 -6-18	1	
301-000U2J0680K	-9-18	1	
301-050C0G0140J	-4-66	2	
301-050C0G0180J	-6-3	1	
301-050C0G0210J	-6-4	1	
3038-0228-402	-4-36	1	
307-0471-00	-14-80	1	
307-1013-04	-4-69	2	
307-1014-04	-4-70	2	
308-000C0G0330J	-5-24	1	
3089-402	-13-56	1	
314-009C0K229D	-14-49	2	
314-011C0G150J	-10-10	1	
314-011C0G220K	-8-13	2	
314-011C0G220K	-10-6		
314-011C0K189B	-8-12	2	
314-011C0K189B	-10-5		
314-022X5P101M	-14-50	4	
314-022Z5U0222M	-14-51	2	
314022X5P0101J	-10-7	1	
314022X5P0102M	-10-8	2	
314022X5P0102M	-11-14		
332K06PP481	-14-62	2	
3329P-L58-101	-5-45	1	
3329P-L58-252	-5-46	1	
3329P-L58-500	-5-44	1	
333-1994-01	-12-8	1	
333-2273-00	-13-47	1	
333-2274-00	-13-74	1	
333-2277-00	-4-9	1	
333-2278-00	-7-15	1	
334-1379-00	-12-42	1	
334-1951-00	-12-43	1	
334-2661-00	-2-21	1	
334-3000-00	-3-7	1	
334-3054-00	-12-10	1	
337-2122-00	-2-5	2	
337-2122-00	-12-14		
337-2122-01	-2-5	1	
337-2124-00	-12-44	1	
337-2128-00	-13-27	1	
337-2172-00	-14-166	1	
337-2207-00	-12-24	1	
337-2234-00	-4-31	1	
337-2262-00	-12-22	1	

*Matched set, must be stocked under NHA.

PART NUMBER	FIG. & INDEX NO.	QTY PER ART.	SMR CODE
337-2387-00	8 -4-65	2	
337-2388-00	-13-39	1	
337-2392-00	-3-22	1	
3386F-T04-101	-10-14	1	
3386F-T04-102	-10-16	1	
3386F-T04-251	-14-84	1	
3386F-T04-501	-10-15	1	
342-0163-00	-13-61	3	
342-0297-00	-13-30	1	
342-0308-00	-3-19	1	
342-0366-00	-4-14	1	
342-0367-00	-7-21	1	
343-0088-00	-7-59	1	
343-0097-00	-4-42	2	
343-0519-00	-5-140	1	
343-0523-00	-12-12	1	
343-0528-00	-13-19	1	
343-0582-00	-4-34	2	
343-0681-00	-4-86	2	
344-0046-00	-2-18	3	
344-0154-00	-14-167	8	
345002	-13-73	1	
348-0080-01	-3-24	4	
348-0141-00	-13-22	2	
348-0141-00	-13-29		
348-0171-00	-12-26	1	
348-0434-00	-13-49	4	
348-0524-00	-2-30	1	
351-0355-00	-5-129	1	
351-0359-00	-5-123	1	
351-0448-01	-8-60	4	
3515-14-11	-3-18	6	
352-0161-00	-7-71	1	
352-0162-00	-7-72	2	
352-0162-00	-13-31		
352-0164-00	-4-101	5	
352-0164-00	-7-73		
352-0167-00	-13-93	2	
352-0169-00	-4-105	8	
352-0169-00	-7-74		
352-0169-00	-12-33		
352-0169-00	-12-36		
352-0169-00	-12-48		
352-0198-00	-12-50	1	
352-0199-00	-13-94	3	
352-0262-00	-4-45	2	
352-0477-00	-4-11	6	

PART NUMBER	FIG. & INDEX NO.	QTY PER ART.	SMR CODE
352-0477-00	8 -7-19		
354-0195-00	-12-11	2	
354-0442-01	-7-9	1	
3540S-561-103	-7-2	1	
35495	-14-8	1	
358-0550-00	-4-8	11	
358-0550-00	-7-13		
358-0550-00	-12-6		
358-0569-00	-7-12	1	
36C600	-10-11	1	
361-0383-00	-5-139	2	
361-0384-00	-10-44	2	
361-0385-00	-11-90	4	
361-0608-00	-8-65	6	
361-0608-00	-10-45		
361-0608-00	-14-168		
361-0761-00	-14-169	1	
366-1031-02	-4-2	2	
366-1219-00	-7-7	1	
366-1346-02	-7-5	1	
366-1512-00	-4-6	1	
366-1559-00	-4-4	16	
366-1559-00	-7-4		
366-1559-00	-12-4		
366-1722-01	-4-3	2	
366-1723-00	-4-5	1	
367-0233-00	-3-8	1	
374-005COG909B	-6-7		
374-005COG909B	-6-23		
376-0029-00	-4-28	3	
376-0029-00	-4-94		
376-0127-00	-13-2	1	
376-0141-00	-7-50	1	
376-0146-00	-5-124	1	
376-0182-00	-4-84	2	
378-0614-00	-12-19	1	
380-0421-00	-5-141	1	
381-CM40943	-10-20	1	
381-CM40951	-10-19	1	
381CM40934	-4-96	2	
381CM40935	-7-52	1	
384-1056-00	-4-24	2	
384-1099-00	-4-25	2	
384-1099-00	-7-23		
384-1101-00	-7-27	3	
384-1129-00	-7-26	2	
384-1129-00	-12-5		
384-1136-00	-7-25	1	

AIR FORCE TO33A1-13-496-1
 NAVELEX 0969-LP-170-0010
 Numerical Index

PART NUMBER	FIG. & INDEX NO.	QTY PER ART.	SMR CODE
384-1311-01	8-13-1	1	
384-1322-00	-7-45	1	
384-1341-00	-7-29	4	
384-1348-00	-12-2	2	
384-1350-00	-12-3	1	
384-1350-02	-4-1	6	
384-1350-02	-7-11		
384-1350-02	-12-1		
384-1351-00	-13-35	1	
384-1366-00	-7-3	2	
384-1389-01	-4-24	2	
384-1389-01	-7-22		
384-1390-00	-7-26	3	
384-1456-00	-4-27	2	
384-1457-00	-4-30	1	
3858Z-B78/203A	-14-91	1	
3858Z-X03-203E	-8-24	2	
3859Z-X04-202A	-14-90	1	
3859Z-X05-103F	-14-89	1	
3859Z-X52-505Z	-14-93	1	
386-2275-00	-2-33	2	
386-3156-00	-7-55	1	
386-3305-00	-12-37	1	
386-3336-00	-12-20	1	
386-3518-00	-12-27	1	
386-3519-00	-13-9	1	
386-3689-00	-2-28	1	
386-3691-00	-13-81	1	
388-CM40915	-4-91	2	
388-4703-00	-12-16	1	
390-0449-02	-3-2	1	
390-049X5P0220K	-5-25	2	
390049X5P0151K	-8-16	5	
390049X5P0151K	-9-3		
390049X5P0151K	-11-18		
390049X5P0470K	-11-13	1	
390049X5P0680K	-5-27	3	
390049X5P0680K	-9-2		
390049X5P0680K	-11-17		
390049X5P0820K	-5-29	2	
390049X5P0820K	-8-19		
401-0322-00	-7-48	4	
401-0369-00	-4-81	2	
401-0370-00	-4-77	4	
407-1909-00	-4-15	2	
407-1922-00	-4-49	1	
410P103	-5-38	1	
426-1072-00	-4-7	18	
426-1072-00	-7-14		
426-1072-00	-12-7		

PART NUMBER	FIG. & INDEX NO.	QTY PER ART.	SMR CODE
426-1240-00	8-12-23	1	
42617-2	-13-83	6	
430P522	-14-60	1	
441-1259-03	-3-23	1	
441-1260-00	-13-23	1	
441-1261-03	-4-103	1	
441-1364-00	-4-60	2	
441-1365-00	-4-99	2	
441-1366-00	-7-65	1	
450-4352-01-0318	-12-9	2	
4522-5050-2C	-13-4	1	
461-S-70	-7-1	1	
46231	-12-46	18	
46231	-12-49		
46231	-13-85		
470-3NT34	-2-1	2	
4704-04-02	-13-60	3	
47350	-5-134	63	
47350	-11-83		
47350	-14-161		
47357	-5-134	68	
47357	-8-57		
47357	-11-84		
47357	-14-162		
47439	-4-100	74	
47439	-4-104		
47439	-7-66		
47439	-12-32		
47439	-12-35		
47439	-12-47		
47439	-13-32		
47439	-13-86		
5-16-6BH	-13-8	2	
5-16-6BH	-13-12		
5R2-1	-2-26	1	
5S10-8	-2-22	1	
5S3-1	-2-23	1	
502D227	-14-75	1	
5082-4403	-7-17	3	
5115-18-.010	-3-17	6	
513-001 5-30	-5-22	4	
513-001-A-2.0-10	-5-23	1	
530-002	-14-46	1	
538-011B7-25	-11-12	2	
57-0180-7D-500B	-5-2	10	
57-0180-7D 500B	-11-2		
670-3551-02	-7-49	1	
670-4846-00	-7-60	1	
670-4847-00	-7-32	1	

PART NUMBER	FIG. & INDEX NO.	QTY PER ART.	SMR CODE
670-4848-00	8 -7-40	1	
670-4849-00	-4-52	1	
670-4850-00	-4-90	1	
670-4850-01	-4-90	1	
670-4852-00	-4-62	2	
670-4853-00	-13-37	1	
670-4855-00	-7-57	1	
672-0613-00	-1-5	1	
672-0614-00	-7-39	1	
672-0615-00	-1-3	1	
672-0616-00	-4-54	1	
672-0617-00	-4-54	1	
70F183A1	-14-3	1	
7101-J61-CB22	-14-45	1	
75060	-4-64	66	
75060	-5-136		
75060	-11-86		
75060	-14-170		
763	-12-38	1	
8005-D-COG-150K	-5-30	8	
8005-D-COG-150K	-8-17		
8005-D-COG-150K	-11-20		
8005-100-COG-201J	-5-31	2	
8005H9AABZ5U104M	-5-26	21	
8005H9AABZ5U104M	-8-18		
8005H9AABZ5U104M	-10-9		
8005H9AABZ5U104M	-11-16		
8005H9AABZ5U104M	-14-53		
8005H9AADW5R103K	-8-15	29	
8005H9AADW5R103K	-11-15		

PART NUMBER	FIG. & INDEX NO.	QTY PER ART.	SMR CODE
8005H9AADW5R103K	8-14-52		
8005H9AADW5R471K	-5-28	12	
8005H9AADW5R471K	-11-19		
8005H9AADW5R472K	-8-14	11	
8111A208E102Z	-5-35	1	
8111B061COG220J	-6-20	1	
8131N039Z5U-104Z	-14-56	1	
8131N145 A 332J	-5-34	1	
8131N145 E 104Z	-5-36	7	
8131N300Z5U0103P	-5-32	2	
855-558Z5U-103Z	-14-54	2	
91A-100ROM	-4-68	3	
91A-100ROM	-5-51		
91A-10001M	-5-48	6	
91A-10001M	-10-17		
91A-10001M	-11-30		
91A-200ROM	-6-8	2	
91A-200ROM	-6-24		
91A-20000M	-14-88	1	
91A-20001M	-5-47	1	
91A-20002M	-14-85	1	
91A-250ROM	-5-50	1	
91A-25000M	-11-31	2	
91A-25000M	-14-87		
91A-25001M	-14-86	1	
91A-50000M	-5-49	6	
91A-50000M	-8-23		
91A-50000M	-10-18		
9663-1 NT-34	-4-19	2	

SECTION X

ILLUSTRATED PARTS BREAKDOWN REFERENCE DESIGNATION INDEX

REFERENCE DESIGNATION	FIG. & INDEX NO.	PART NUMBER
A1	8 -4-90	670-4850-00
A2	-4-62	670-4852-00
A3	-4-90	670-4850-01
A4	-4-62	670-4852-00
A5	-4-52	670-4849-00
A6	-7-57	670-4855-00
A7	-7-32	670-4847-00
A8	-7-60	670-4846-00
A9	-7-40	670-4848-00
A10	-7-49	670-3551-02
A11	-13-37	670-4853-00
A12	-12-16	388-4703-00
CR235	-14-24	1N4152
CR236	-14-24	1N4152
CR351	-14-24	1N4152
CR352	-14-24	1N4152
CR353	-14-24	1N4152
CR358	-14-24	1N4152
CR372	-14-24	1N4152
CR373	-14-24	1N4152
CR504	-14-24	1N4152
CR505	-14-24	1N4152
CR506	-14-24	1N4152
CR513	-14-24	1N4152
CR514	-14-24	1N4152
CR518	-14-24	1N4152
CR524	-14-21	152-0061-00
CR525	-14-21	152-0061-00
CR528	-14-24	1N4152
CR541	-14-21	152-0061-00
CR552	-14-23	152-0107-04
CR553	-14-23	152-0107-04

REFERENCE DESIGNATION	FIG. & INDEX NO.	PART NUMBER
CR554	8-14-33	1N4935
CR555	-14-23	152-0107-04
CR556	-14-24	1N4152
CR557	-14-33	1N4935
CR582	-14-37	152-0629-00
CR584	-14-22	152-0066-00
CR721	-14-35	152-0488-00
CR734	-14-24	1N4152
CR735	-14-24	1N4152
CR738	-14-22	152-0066-00
CR741	-14-36	MDA960-1
CR744	-14-24	1N4152
CR748	-14-22	152-0066-00
CR762	-14-24	1N4152
CR763	-14-24	1N4152
CR764	-14-24	1N4152
CR765	-14-24	1N4152
CR766	-14-24	1N4152
CR768	-14-22	152-0066-00
CR2112	-8-6	CD12676
CR2114	-8-5	1N4152
CR2126	-8-5	1N4152
CR2146	-8-5	1N4152
CR2213	-8-6	CD12676
CR2214	-8-5	1N4152
CR2261	-8-5	1N4152
CR2262	-8-5	1N4152
CR2284	-7-18	OSL-16L-100
CR2297	-8-5	1N4152
CR2298	-8-5	1N4152
CR2299	-8-5	1N4152
CR2605	-11-6	1N4152

AIR FORCE TO33A1-13-496-1
 NAVELEX 0969-LP-170-0010
 Reference Designation Index

REFERENCE DESIGNATION	FIG. & INDEX NO.	PART NUMBER
CR2607	8-11-6	1N4152
CR2608	-11-6	1N4152
CR2609	-11-6	1N4152
CR2612	-11-6	1N4152
CR2617	-11-6	1N4152
CR2618	-11-6	1N4152
CR2621	-11-6	1N4152
CR2622	-11-6	1N4152
CR2623	-11-6	1N4152
CR2630	-11-6	1N4152
CR2655	-11-6	1N4152
CR2656	-11-6	1N4152
CR2658	-11-6	1N4152
CR2675	-11-6	1N4152
CR2686	-11-6	1N4152
CR2690	-11-6	1N4152
CR2692	-11-6	1N4152
CR2694	-11-6	1N4152
CR2695	-11-6	1N4152
CR2696	-11-6	1N4152
CR2705	-11-6	1N4152
CR2706	-11-6	1N4152
CR2707	-11-6	1N4152
CR2708	-11-6	1N4152
CR2709	-11-6	1N4152
CR2710	-11-6	1N4152
CR2711	-11-6	1N4152
CR2716	-11-6	1N4152
CR2717	-11-6	1N4152
CR2718	-11-6	1N4152
CR2741	-11-6	1N4152
CR2742	-11-6	1N4152
CR2743	-11-6	1N4152
CR2755	-7-17	150-1001-02
CR2756	-11-6	1N4152
CR2757	-11-6	1N4152
CR2759	-11-6	1N4152
CR2763	-11-6	1N4152
CR2764	-11-6	1N4152
CR2765	-11-6	1N4152
CR2766	-11-6	1N4152
CR2767	-11-6	1N4152
CR2773	-11-6	1N4152
CR2774	-11-6	1N4152
CR2778	-11-6	1N4152
CR2786	-11-6	1N4152
CR2788	-11-6	1N4152
CR2795	-11-6	1N4152
CR2920	-7-17	150-1001-02
CR3129	-7-17	150-1001-02

REFERENCE DESIGNATION	FIG. & INDEX NO.	PART NUMBER
CR4124	8 -5-16	CD12676
CR4142	-4-12	150-1001-02
CR4224	-5-16	CD12676
CR4242	-4-12	150-1001-02
CR4284	-5-15	1N4152
CR4312	-5-15	1N4152
CR4318	-5-15	1N4152
CR4322	-5-15	1N4152
CR4328	-5-15	1N4152
CR4382	-5-15	1N4152
CR4416	-5-17	152-0269-00
CR4417	-5-17	152-0269-00
CR4418	-5-15	1N4152
CR4419	-5-15	1N4152
C232	-14-47	2222-801-96138
C233	-14-49	314-009COK229D
C236	-14-61	192P2249R8
C244	-14-65	223K02PT485
C246	-14-51	314-02225U0222M
C272	-14-47	2222-801-96138
C273	-14-49	314-009COK229D
C284	-14-65	223K02PT485
C286	-14-51	314-02225U0222M
C288	-14-53	8005H9AABZ5U104M
C354	-14-58	19C611
C376	-14-64	223J02PT485
C383	-14-50	314-022X5P101M
C386	-14-70	150D475X0035B2
C503	-14-58	19C611
C515	-14-46	530-002
C516	-14-48	2222-801-96139
C518	-14-55	273C20
C522	-14-62	332K06PP481
C523	-14-57	274C10
C524	-14-57	274C10
C528	-14-56	8131N039Z5U-104Z
C533	-14-63	PT605C473M
C543	-14-69	30D105F150BA2
C546	-14-53	8005H9AABZ5U104M
C548	-14-66	PP680C823K
C558	-14-73	T11C825M075AS
C564	-14-60	430P522
C566	-14-62	332K06PP481
C572	-14-52	8005H9AADW5R103K
C575	-14-52	8005H9AADW5R103K
C576	-14-53	8005H9AABZ5U104M
C577	-14-53	8005H9AABZ5U104M
C582	-14-75	502D227

AIR FORCE TO33A1-13-496-1
 NAVELEX 0969-LP-170-0010
 Reference Designation Index

REFERENCE DESIGNATION	FIG. & INDEX NO.	PART NUMBER
C584	8-14-68	30D205F150BB9
C707	-14-59	19C242B
C708	-14-54	855-558Z5U-103Z
C709	-14-54	855-558Z5U-103Z
C721	-14-72	20-36435
C722	-14-50	314-022X5P101M
C723	-14-63	PT605C473M
C725	-14-65	223K02PT485
C735	-14-63	PT605C473M
C738	-14-67	30D506G050DD9
C741	-14-71	290-0508-01
C743	-14-50	314-022X5P101M
C748	-14-74	290-0746-00
C761	-14-71	290-0508-01
C763	-14-50	314-022X5P101M
C768	-14-74	290-0746-00
C773	-14-53	8005H9AABZ5U104M
C2103	-8-12	314-011COK189B
C2104	-8-19	390049X5P0820K
C2105	-8-17	8005-D-COG-150K
C2106	-8-13	314-011C0G220K
C2109	-8-15	8005H9AADW5R103K
C2118	-8-15	8005H9AADW5R103K
C2119	-8-15	8005H9AADW5R103K
C2130	-8-14	8005H9AADW5R472K
C2131	-8-14	8005H9AADW5R472K
C2132	-8-14	8005H9AADW5R472K
C2133	-8-14	8005H9AADW5R472K
C2144	-8-15	8005H9AADW5R103K
C2161	-8-21	290-0776-00
C2162	-8-21	290-0776-00
C2170	-8-16	390049X5P0151K
C2172	-8-14	8005H9AADW5R472K
C2175	-8-17	8005-D-COG-150K
C2182	-8-15	8005H9AADW5R103K
C2186	-8-15	8005H9AADW5R103K
C2190	-8-15	8005H9AADW5R103K
C2198	-8-15	8005H9AADW5R103K
C2199	-8-15	8005H9AADW5R103K
C2203	-10-5	314-011COK189B
C2204	-10-7	314022X5P0101J
C2205	-10-10	314-011C0G150J
C2206	-10-6	314-011C0G220K
C2212	-8-15	8005H9AADW5R103K
C2216	-8-17	8005-D-COG-150K
C2218	-8-15	8005H9AADW5R103K
C2226	-8-21	290-0776-00
C2227	-8-21	290-0776-00
C2229	-8-15	8005H9AADW5R103K
C2230	-8-14	8005H9AADW5R472K

REFERENCE DESIGNATION	FIG. & INDEX NO.	PART NUMBER
C2231	8-8-14	8005H9AADW5R472K
C2232	-8-14	8005H9AADW5R472K
C2233	-8-14	8005H9AADW5R472K
C2243	-8-15	8005H9AADW5R103K
C2246	-8-15	8005H9AADW5R103K
C2248	-8-15	8005H9AADW5R103K
C2256	-8-16	390049X5P0151K
C2258	-8-14	8005H9AADW5R472K
C2265	-8-15	8005H9AADW5R103K
C2275	-8-17	8005-D-COG-150K
C2278	-8-15	8005H9AADW5R103K
C2279	-8-15	8005H9AADW5R103K
C2280	-8-20	223K02PT485
C2284	-8-14	8005H9AADW5R472K
C2287	-8-18	8005H9AABZ5U104M
C2297	-8-15	8005H9AADW5R103K
C2625	-11-15	8005H9AADW5R103K
C2638	-11-15	8005H9AADW5R103K
C2634	-11-19	8005H9AADW5R471K
C2641	-11-16	8005H9AABZ5U104M
C2652	-11-15	8005H9AADW5R103K
C2683	-11-21	C40A820J
C2684	-11-12	538-011B7-25
C2685	-11-23	162D225X0020CD2
C2686	-11-20	8005-D-COG-150K
C2691	-11-15	8005H9AADW5R103K
C2703	-11-15	8005H9AADW5R103K
C2712	-11-23	162D225X0020CD2
C2719	-11-16	8005H9AABZ5U104M
C2744	-11-23	162D225X0020CD2
C2752	-11-16	8005H9AABZ5U104M
C2757	-11-26	162D274X9035BC2
C2758	-11-18	390049X5P0151K
C2759	-11-17	390049X5P0680K
C2762	-11-19	8005H9AADW5R471K
C2763	-11-15	8005H9AADW5R103K
C2764	-11-22	PT605C473M
C2765	-11-27	150D564X0100A2
C2766	-11-23	162D225X0020CD2
C2767	-11-24	150D106X0015B2
C2773	-11-14	314-022X5P0102M
C2781	-11-25	162D105X0035CD2
C2783	-11-21	C40A820J
C2784	-11-12	538-011B7-25
C2785	-11-23	162D225X0020CD2
C2786	-11-20	8005-D-COG-150K
C2788	-11-15	8005H9AADW5R103K
C2789	-11-23	162D225X0020CD2
C2791	-11-15	8005H9AADW5R103K
C2794	-11-13	390049X5P0470K

AIR FORCE T033A1-13-496-1
 NAVELEX 0969-LP-170-0010
 Reference Designation Index

REFERENCE DESIGNATION	FIG. & INDEX NO.	PART NUMBER
C2798	8-11-18	390049X5P0151K
C2812	-11-28	290-0746-00
C2814	-11-28	290-0746-00
C2911	-10-9	8005H9AABZ5U104M
C2913	-10-11	36C600
C2917	-10-8	314022X5P0102M
C2919	-10-9	8005H9AABZ5U104M
C2941	-10-12	D155F201F0
C3122	-9-2	390049X5P0680K
C3125A*	-7-37	285-0753-00
C3125B*	-7-38	285-0782-00
C3125C*	-7-39	285-1060-01
C3125D*	-7-38	285-0782-00
C3125E*	-7-37	285-0753-00
C3137	-9-3	390049X5P0151K
C3242	-9-18	301-000U2J0680K
C4101	-4-59	2222-801-96138
C4102	-4-18	285-1132-00
C4104	-4-70	307-1014-04
C4105	-4-70	307-1014-04
C4107	-4-69	307-1013-04
C4108	-4-69	307-1013-04
C4109	-4-67	301-000C0J0339C
C4110	-4-66	301-050C0G0140J
C4123	-5-32	8131N300Z5U0103P
C4125	-5-36	8131N145 E 104Z
C4159	-5-35	8111A208E102Z
C4160	-6-4	301-050C0G0210J
C4162	-6-5	301-000C0J0399C
C4165	-6-3	301-050C0G0180J
C4167	-6-7	374-005C0G909B
C4168	-6-6	301-000C0J0229C
C4173	-5-22	513-001 5-30
C4174	-5-22	513-001 5-30
C4175	-5-31	8005-100-COG-201J
C4191	-5-36	8131N145 E 104Z
C4192	-5-36	8131N145 E 104Z
C4201	-4-59	2222-801-96138
C4202	-4-18	285-1132-00
C4204	-4-70	307-1014-04
C4205	-4-70	307-1014-04
C4207	-4-69	307-1013-04
C4208	-4-69	307-1013-04
C4209	-4-67	301-000C0J0339C
C4210	-4-66	301-050C0G0140J
C4223	-5-32	8131N300Z5U0103P
C4225	-5-36	8131N145 E 104Z
C4260	-6-22	301-000C0H0759D
C4262	-6-18	301-000C0K0189B
C4265	-6-19	301-000C0G0240J

REFERENCE DESIGNATION	FIG. & INDEX NO.	PART NUMBER
C4266	8-6-20	8111B061COG220J
C4267	-6-23	374-005COG909B
C4268	-6-21	301-000C0J0279C
C4272	-5-30	8005-D-COG-150K
C4273	-5-36	8131N145 E 104Z
C4275	-5-31	8005-100-COG-201J
C4287	-5-26	8005H9AABZ5U104M
C4288	-5-26	8005H9AABZ5U104M
C4289	-5-28	8005H9AADW5R471K
C4292	-5-36	8131N145 E 104Z
C4316	-5-38	410P103
C4327	-5-26	8005H9AABZ5U104M
C4333	-5-39	162D275X9015CD2
C4335	-5-27	390049X5P0680K
C4336	-5-39	162D275X9015CD2
C4342	-5-23	513-001-A-2.0-10
C4349	-5-28	8005H9AADW5R471K
C4359	-5-28	8005H9AADW5R471K
C4363	-5-28	8005H9AADW5R471K
C4365	-5-25	390-049X5P0220K
C4373	-5-28	8005H9AADW5R471K
C4376	-5-26	8005H9AABZ5U104M
C4375	-5-25	390-049X5P0220K
C4377	-5-26	8005H9AABZ5U104M
C4388	-5-30	8005-D-COG-150K
C4389	-5-37	D151E111F0
C4404	-5-24	308-000C0G0330J
C4405	-5-21	281-0205-00
C4406	-5-34	8131N145 A 332J
C4408	-5-33	273C20
C4409	-5-29	390049X5P0820K
C4410	-5-21	281-0205-00
C4411	-5-28	8005H9AADW5R471K
C4412	-5-22	513-001 5-30
C4423	-5-28	8005H9AADW5R471K
C4424	-5-26	8005H9AABZ5U104M
C4425	-5-26	8005H9AABZ5U104M
C4432	-5-26	8005H9AABZ5U104M
C4433	-5-28	8005H9AADW5R471K
C4447	-5-22	513-001-5-30
C4457	-5-36	8131N145 E 104Z
C4461	-5-28	8005H9AADW5R471K
C4466	-5-26	8005H9AABZ5U104M
C4471	-5-28	8005H9AADW5R471K
C4474	-5-26	8005H9AABZ5U104M
DL4400	-4-33	119-0860-00
DS563	-14-6	NE2T-A1AT
DS564	-14-6	NE2T-A1AT
DS784	-12-18	2112D
DS786	-12-18	2112D

*Matched set, must be stocked under NHA.

REFERENCE DESIGNATION	FIG. & INDEX NO.	PART NUMBER
F558	8-14-43	AGC 1/4
F700	-13-72	AGC 1
F736	-14-44	AGC 3/10
F746	-14-42	AGC 2
F768	-14-42	AGC 2
J2	-14-164	000-201-4986
J4	-14-164	000-201-4986
J358	-14-163	131-1003-00
J359	-13-52	28JR166-1
J387	-12-9	450-4352-01-0318
J388	-12-9	450-4352-01-0318
J503	-14-163	131-1003-00
J513	-13-52	28JR166-1
J2105	-7-30	28JR166-1
J2205	-7-30	28JR166-1
J2716	-11-85	131-1003-00
J2717	-13-52	28JR166-1
J4100	-4-19	9663-1 NT-34
J4200	-4-19	9663-1 NT-34
J4287	-5-132	131-1003-00
J4289	-13-52	28JR166-1
LR4466	-5-5	108-0328-00
LR4476	-5-5	108-0328-00
L386	-14-1	108-0245-00
L554	-14-4	108-0820-00
L558	-14-2	108-0422-00
L571	-12-31	108-0818-00
L573	-12-34	108-0819-00
L582	-14-3	70F183A1
L2635	-11-1	108-0724-00
L2688	-11-2	57-0180-7D 500B
L2698	-11-2	57-0180-7D 500B
L2788	-11-2	57-0180-7D 500B
L2798	-11-2	57-0180-7D 500B
L4128	-5-2	57-0180-7D-500B
L4135	-5-2	57-0180-7D-500B
L4228	-5-2	57-0180-7D-500B
L4237	-5-2	57-0180-7D-500B
L4262	-5-2	57-0180-7D-500B
L4264	-5-2	57-0180-7D-500B
L4378	-5-1	108-0262-00
L4388	-5-1	108-0262-00
L4401	-5-3	108-0570-00
L4403	-5-3	108-0570-00
L4445	-5-4	120-1094-00
L4455	-5-4	120-1094-00
P700	-13-44	F-11935-6
Q232	-14-10	2N3906
Q234	-14-11	151-0190-00
Q244	-14-16	151-0347-00

REFERENCE DESIGNATION	FIG. & INDEX NO.	PART NUMBER
Q246	8-14-17	151-0350-00
Q274	-14-11	151-0190-00
Q284	-14-16	151-0347-00
Q286	-14-17	151-0350-00
Q356	-14-11	151-0190-00
Q358	-14-11	151-0190-00
Q376	-14-15	151-0342-00
Q382	-14-15	151-0342-00
Q386	-14-9	151-0164-00
Q514	-14-12	151-0192-00
Q518	-14-10	2N3906
Q524	-14-17	151-0350-00
Q526	-14-16	151-0347-00
Q544	-14-7	2N2484
Q548	-14-10	2N3906
Q552	-14-20	151-0426-02
Q556	-14-18	151-0364-00
Q732	-14-16	151-0347-00
Q734	-14-16	151-0347-00
Q736	-13-58	151-0349-00
Q742	-14-14	2N2222A
Q744	-14-8	35495
Q746	-13-58	151-0349-00
Q764	-14-13	2N2907A
Q766	-14-13	2N2907A
Q768	-13-58	151-0349-00
Q784	-14-19	151-0405-00
Q2112	-8-4	151-1042-00
Q2114	-8-4	151-1042-00
Q2116	-8-2	151-0190-00
Q2122	-8-3	151-0472-00
Q2142	-8-3	151-0472-00
Q2212	-8-4	151-1042-00
Q2214	-8-4	151-1042-00
Q2216	-8-2	151-0190-00
Q2284	-8-1	2N3906
Q2350	-10-1	2N3906
Q2356	-10-1	2N3906
Q2602	-11-3	2N3906
Q2604	-11-3	2N3906
Q2618	-11-4	151-0190-00
Q2620	-11-4	151-0190-00
Q2622	-11-3	2N3906
Q2624	-11-4	151-0190-00
Q2629	-11-4	151-0190-00
Q2632	-11-3	2N3906
Q2636	-11-3	2N3906
Q2672	-11-4	151-0190-00
Q2674	-11-4	151-0190-00
Q2682	-11-5	151-1042-00
Q2684	-11-5	151-01042-00

AIR FORCE TO33A1-13-496-1
 NAVELEX 0969-LP-170-0010
 Reference Designation Index

REFERENCE DESIGNATION	FIG. & INDEX NO.	PART NUMBER
Q2686	8-11-3	2N3906
Q2696	-11-3	2N3906
Q2702	-11-3	2N3906
Q2704	-11-3	2N3906
Q2712	-11-4	151-0190-00
Q2782	-11-5	151-1042-00
Q2784	-11-5	151-1042-00
Q2786	-11-3	2N3906
Q2788	-11-4	151-0190-00
Q4124	-5-14	SF93007
Q4224	-5-14	SF93007
Q4282	-5-13	151-0472-00
Q4288	-5-11	S039650
Q4316	-5-8	151-0190-00
Q4326	-5-8	151-0190-00
Q4334	-5-12	2N3947
Q4338	-5-8	151-0190-00
Q4342	-5-9	151-0434-00
Q4352	-5-9	151-0434-00
Q4362	-5-13	151-0472-00
Q4372	-5-13	151-0472-00
Q4384	-5-7	S6075
Q4421	-5-13	151-0472-00
Q4429	-5-9	151-0434-00
Q4431	-5-13	151-0472-00
Q4439	-5-9	151-0434-00
Q4447	-5-10	151-0447-00
Q4457	-5-10	151-0447-00
Q4463	-4-40	151-0446-00
Q4473	-4-40	151-0446-00
RT4416	-5-41	2D1596
RT4419	-5-42	1DE104-K-220EC
R232	-14-154	CECTO-8871F
R233	-14-154	CECTO-8871F
R235	-14-147	MFF1816G47501F
R236	-14-141	MFF1816G54900F
R241	-14-115	CB4315
R243	-14-76	EB2235
R244	-14-136	MFF1816G909ROF
R245	-14-124	CB5625
R246	-14-117	CB4705
R247	-14-94	CB1015
R272	-14-154	CECTO-8871F
R273	-14-154	CECTO-8871F
R275	-14-105	CB1825
R276	-14-115	CB4315
R283	-14-76	EB2235
R284	-14-136	MFF1816G909ROF

REFERENCE DESIGNATION	FIG. & INDEX NO.	PART NUMBER
R285	8-14-127	CB6815
R286	-14-117	CB4705
R287	-14-94	CB1015
R288	-14-125	CB5635
R352	-14-104	CB1535
R353	-14-119	CB4725
R354	-14-109	CB2225
R356	-14-110	CB2725
R358	-14-121	CB5115
R372	-14-111	CB2735
R373	-14-131	CB9125
R374	-14-104	CB1535
R375	-14-143	MFF1816G16901F
R376	-14-96	CB1145
R377	-14-126	CB6235
R382	-14-97	CB1145
R383	-14-106	CB1835
R386	-14-84	3386F-T04-251
R387	-14-133	MFF1816G619ROF
R388	-14-132	MFF1816G187ROF
R502	-14-95	CB1025
R503	-14-135	MFF1816G665ROF
R504	-14-99	CB1225
R505	-14-81	RS2B-B16000J
R506	-14-113	CB3905
R512	-14-145	MFF1816G24901F
R513	-14-153	CECTO-4871F
R514	-14-139	MFF1816G42200F
R515	-14-110	CB2725
R516	-14-155	CECTO-2212F
R517	-14-107	CB2015
R521	-14-122	CB5125
R522	-14-129	CB8235
R523	-14-130	CB9115
R524	-14-76	EB2235
R525	-14-128	CB8215
R526	-14-103	CB1515
R532	-14-86	91A-25001M
R533	-14-95	CB1025
R541	-14-96	CB1045
R542	-14-96	CB1045
R543	-14-120	CB4745
R544	-14-95	CB1025
R546	-14-100	CB1235
R547	-14-101	CB1315
R548	-14-94	CB1015
R553	-14-94	CB1015
R554	-14-98	CB1205

REFERENCE DESIGNATION	FIG. & INDEX NO.	PART NUMBER
R556	8-14-121	CB5115
R563A,B,C,D	-14-80	307-0471-00
R564	-14-93	3859Z-X52-505Z
R566A/B	-14-92	D388-CM40910
R571	-14-90	3859Z-X04-202A
R572	-14-85	91A-2002M
R573	-14-88	91A-20000M
R574	-14-126	CB6235
R575	-14-123	CB5135
R576	-14-91	3858Z-B78-203A
R577	-14-118	CB4715
R721	-14-112	CB3035
R722	-14-78	GB3025
R723	-14-142	MFF1816G11801F
R725	-14-121	CB5115
R728	-14-79	GB4725
R731	-14-108	CB2045
R732	-14-134	MFF1816G634ROF
R733	-14-146	MFF1816G31601F
R734	-14-83	BWH-LR800J
R735	-14-149	MFF1816D40201D
R736	-14-87	91A-25000M
R737	-14-148	MFF1816D15001D
R738	-14-77	GB2425
R740	-14-110	CB2725
R741	-14-152	MFF1816D27001C
R742	-14-150	MFF1816D50000C
R743	-14-116	CB4325
R745	-14-104	CB1535
R746	-14-137	MFF1816G11300F
R747	-14-140	MFF1816G52300F
R748	-14-82	BWH-R5100J
R761	-14-110	CB2725
R762	-14-150	MFF1816D50000C
R763	-14-151	MFF1816D32001C
R764	-14-116	CB4325
R765	-14-144	MFF1816G21001F
R766	-14-138	MFF1816G30100F
R767	-14-94	CB1015
R768	-14-82	BWH-R5100J
R769	-14-114	CB3915
R772	-14-111	CB2735
R773	-14-95	CB1025
R776	-14-102	CB1325
R777	-14-95	CB1025
R782	-14-110	CB2725
R785	-14-89	3859Z-X05-103F
R2101	-7-22	CB2705
R2103	-8-43	CB3355
R2104	-8-54	CB9135

REFERENCE DESIGNATION	FIG. & INDEX NO.	PART NUMBER
R2105	8 -8-29	CB1055
R2106	-8-48	CB5145
R2112	-8-29	CB1055
R2113	-8-31	CB7505
R2115	-8-27	CB1025
R2116	-8-56	MFF1816G15000F
R2118	-8-46	CB4705
R2119	-8-46	CB4705
R2121	-8-53	CB7505
R2124	-8-46	CB4705
R2125	-8-40	CB2715
R2126	-8-51	CB6215
R2127	-8-37	CB2205
R2128	-8-56	MFF1816G15000F
R2130	-8-55	MFF1816G26700F
R2131	-8-55	MFF1816G26700F
R2132	-8-55	MFF1816G26700F
R2133	-8-55	MFF1816G26700F
R2135	-8-47	CB4735
R2136	-8-47	CB4735
R2137	-8-47	CB4735
R2138	-8-47	CB4735
R2141	-8-53	CB7505
R2144	-8-46	CB4705
R2145	-8-40	CB2715
R2146	-8-51	CB6215
R2147	-8-37	CB2205
R2148	-8-56	MFF1816G15000F
R2151	-8-53	CB7505
R2153	-8-24	3858Z-X03-203E
R2158	-8-56	MFF1816G15000F
R2164	-8-30	CB1325
R2165	-8-49	CB5615
R2167	-8-41	CB3025
R2168	-8-28	CB1035
R2170	-8-56	MFF1816G15000F
R2171	-8-44	CB3625
R2172	-8-55	MFF1816G26700F
R2173	-8-50	CB6205
R2174	-8-38	CB2225
R2179	-8-38	CB2225
R2183	-8-23	91A-50000M
R2185	-8-23	91A-50000M
R2186	-8-30	CB1325
R2189	-8-38	CB2225
R2190	-8-55	MFF1816G26700F
R2191	-8-47	CB4735
R2198	-8-22	CB51G5
R2199	-8-25	CB1005
R2201	-7-22	CB2705

AIR FORCE TO33A1-13-496-1
 NAVELEX 0969-LP-170-0010
 Reference Designation Index

REFERENCE DESIGNATION	FIG. & INDEX NO.	PART NUMBER
R2203	8-10-26	CB3355
R2204	-10-33	CB9135
R2205	-10-21	CB1055
R2206	-10-29	CB5145
R2212	-8-29	CB1055
R2213	-8-31	CB7505
R2215	-8-27	CB1025
R2216	-8-45	CB3905
R2218	-8-46	CB4705
R2221	-8-56	MFF1816G15000F
R2222	-8-56	MFF1816G15000F
R2223	-8-56	MFF1816G15000F
R2224	-8-56	MFF1816G15000F
R2225	-8-33	CB1535
R2228	-8-28	CB1035
R2229	-8-46	CB4705
R2230	-8-55	MFF1816G26700F
R2231	-8-55	MFF1816G26700F
R2232	-8-55	MFF1816G26700F
R2233	-8-55	MFF1816G26700F
R2235	-8-47	CB4735
R2236	-8-47	CB4735
R2237	-8-47	CB4735
R2238	-8-47	CB4735
R2242	-8-47	CB4735
R2243	-8-55	MFF1816G26700F
R2245	-8-23	91A-50000M
R2246	-8-30	CB1325
R2249	-8-23	91A-50000M
R2252	-8-30	CB1325
R2253	-8-24	3858Z-X03-203E
R2254	-8-49	CB5615
R2255	-8-41	CB3025
R2256	-8-56	MFF1816G15000F
R2257	-8-44	CB3625
R2258	-8-55	MFF1816G26700F
R2261	-8-35	CB2025
R2262	-8-35	CB2025
R2264	-8-42	CB3335
R2265	-8-39	CB2235
R2271	-8-38	CB2225
R2272	-8-38	CB2225
R2273	-8-50	CB6205
R2275	-8-32	CB1525
R2278	-8-22	CB51G5
R2279	-8-25	CB1005
R2280	-8-52	CB6815
R2281	-8-47	CB4735
R2283	-8-47	CB4735
R2284	-8-34	CB1545

REFERENCE DESIGNATION	FIG. & INDEX NO.	PART NUMBER
R2286	8 -8-36	CB2045
R2287	-8-38	CB2225
R2288	-8-38	CB2225
R2289	-8-26	CB1015
R2299	-8-27	CB1025
R2352	-10-24	CB2705
R2354	-10-28	CB6815
R2356	-10-24	CB2705
R2358	-10-28	CB6815
R2603	-11-75	CB9105
R2605	-11-39	CB1225
R2610	-11-33	CB1025
R2612	-11-44	CB1825
R2613	-10-25	CB2235
R2614	-10-25	CB2235
R2615	-10-17	91A-10001M
R2616	-11-63	CB4735
R2617	-11-63	CB4735
R2618	-11-34	CB1035
R2620	-11-61	CB4715
R2622	-11-51	CB2235
R2623	-11-62	CB4725
R2625	-11-73	CB8215
R2626	-11-36	CB1125
R2627	-11-47	CB2015
R2630	-11-38	CB1215
R2632	-11-69	CB6225
R2633	-11-55	CB3305
R2634	-11-59	CB3915
R2635	-11-46	CB2005
R2636	-11-69	CB6225
R2637	-11-55	CB3305
R2638	-11-53	CB3015
R2640	-11-78	MFF1816G33200F
R2641	-11-76	MFF1816G22100F
R2652	-11-77	MFF1816G23700F
R2653	-11-34	CB1035
R2654	-11-62	CB4725
R2655	-11-50	CB2225
R2656	-11-49	CB2215
R2657	-11-74	CB8225
R2661	-11-41	CB1325
R2662	-11-58	CB3625
R2671	-11-52	CB2725
R2673	-11-44	CB1825
R2675	-11-62	CB4725
R2678	-11-70	CB6815
R2682	-11-30	91A-10001M
R2683	-11-63	CB4735
R2684	-11-54	CB3035

REFERENCE DESIGNATION	FIG. & INDEX NO.	PART NUMBER
R2685	8-11-48	CB2035
R2686	-11-52	CB2725
R2687	-11-40	CB1235
R2691	-11-63	CB4735
R2692	-11-57	CB3325
R2693	-11-34	CB1035
R2694	-11-62	CB4725
R2695	-11-34	CB1035
R2696	-11-57	CB3325
R2697	-11-32	CB1015
R2699	-11-49	CB2215
R2701	-11-54	CB3035
R2703	-11-75	CB9105
R2705	-11-33	CB1025
R2708	-11-50	CB2225
R2710	-11-62	CB4725
R2711	-11-33	CB1025
R2712	-11-29	CB47G5
R2713	-10-25	CB2235
R2714	-10-25	CB2235
R2715	-10-17	91A-10001M
R2716	-11-61	CB4715
R2718	-11-59	CB3915
R2719	-11-29	CB47G5
R2741	-11-71	CB6845
R2742	-11-45	CB1835
R2743	-11-42	CB1525
R2744	-11-81	MFF1816G84501F
R2745	-11-80	MFF1816G56200F
R2746	-11-62	CB4725
R2747	-11-79	MFF1816G45300F
R2748	-11-31	91A-25000M
R2749	-7-2	3540S-561-103
R2751	-11-62	CB4725
R2752	-11-64	CB4745
R2753	-11-35	CB1045
R2755	-11-70	CB6815
R2757	-11-68	CB5645
R2759	-11-39	CB1225
R2762	-11-72	CB7525
R2763	-11-57	CB3325
R2764	-11-57	CB3325
R2765	-11-57	CB3325
R2766	-11-57	CB3325
R2767	-11-57	CB3325
R2774	-11-57	CB3325
R2776	-11-67	CB5635
R2777	-10-20	381-CM40943
R2780	-11-60	CB4705
R2781	-11-32	CB1015

REFERENCE DESIGNATION	FIG. & INDEX NO.	PART NUMBER
R2782	8-11-30	91A-10001M
R2783	-11-63	CB4735
R2784	-11-54	CB3035
R2785	-11-48	CB2035
R2786	-11-52	CB2725
R2787	-11-40	CB1235
R2788	-11-33	CB1025
R2789	-11-37	CB1135
R2790	-11-74	CB8225
R2791	-11-61	CB4715
R2792	-11-57	CB3325
R2793	-11-34	CB1035
R2794	-11-65	CB4755
R2795	-11-43	CB1535
R2796	-11-63	CB4735
R2797	-11-32	CB1015
R2798	-11-66	CB5605
R2910	-10-30	CB7525
R2911	-10-13	CB47G5
R2912	-10-22	CB1125
R2913A/B	-10-19	381-CM40951
R2914	-10-32	CB9115
R2916	-10-15	3386F-T04-501
R2917	-10-31	CB8205
R2919	-10-13	CB47G5
R2920	-11-70	CB6815
R2922	-10-35	MFF1816G16900F
R2923	-10-16	3386F-T04-102
R2925	-10-14	3386F-T04-101
R2927	-10-34	MFF1816G130ROF
R2932	-10-18	91A-50000M
R2933	-10-36	MFF1816G11501F
R2934	-10-36	MFF1816G11501F
R2936	-10-23	CB1835
R2937	-10-23	CB1835
R2942	-10-37	MFF1816G26101F
R2943	-10-27	CB4705
R2944	-10-27	CB4705
R3113	-9-11	MFF1816D75001B
R3114	-9-13	MFF1816D37501B
R3115	-9-13	MFF1816D37501B
R3122	-9-7	CB3915
R3123	-9-15	HMF188D22503B
R3124	-9-12	MFF1816D75002B
R3125	-9-14	MFF1816D37502B
R3127	-9-14	MFF1816D37502B
R3128/S3128	-7-52	381CM40935
R3129	-11-56	CB3315
R3132	-9-4	CB1335
R3133	-9-10	CB9135

AIR FORCE TO33A1-13-496-1
 NAVELEX 0969-LP-170-0010
 Reference Designation Index

REFERENCE DESIGNATION	FIG. & INDEX NO.	PART NUMBER
R3134	8 -9-5	CB2235
R3135	-9-6	CB2245
R3136	-9-8	CB3935
R3137	-9-9	CB2255
R3222	-9-23	MFF1816D37502B
R3223	-9-23	MFF1816D37502B
R3224	-9-21	MFF1816D75002B
R3225	-9-24	HMF188D22503B
R3238	-9-20	MFF1816D75001B
R3236	-9-22	MFF1816D37501B
R3237	-9-22	MFF1816D37501B
R3242	-9-19	CB3915
R4101	-4-17	CB5105
R4102	-6-11	BB1055
R4103	-6-10	CB5105
R4105	-4-72	CB5605
R4106	-4-68	91A-100ROM
R4108	-4-72	CB5605
R4109	-4-71	CB6815
R4122	-5-119	MFF1816G10003F
R4123	-5-77	CB4745
R4125	-5-52	CB1005
R4126	-5-62	CB2005
R4127	-5-62	CB2005
R4134	-5-48	91A-10001M
R4135	-5-55	CB1035
R4136	-5-60	CB1515
R4142	-5-68	CB3015
R4143/S4143	-4-96	381CM40934
R4144	-5-70	CB3325
R4145	-5-64	CB2025
R4153	-4-91	388-CM40915
R4154	-5-61	CB1825
R4156	-5-53	CB1015
R4159	-5-87	BB1005
R4160	-6-13	MFF1816G200ROD
R4161	-6-12	MFF1816G150ROD
R4162	-6-9	CB1315
R4163	-5-120	MFF1816D400ROC
R4164	-6-15	MFF1816G800ROD
R4165	-6-13	MFF1816G200ROD
R4166	-6-12	MFF1816G150ROD
R4167	-6-8	91A-200ROM
R4168	-6-14	MFF1816G133R3D
R4171	-5-91	BB4715
R4173	-5-50	91A-250ROM
R4174	-5-51	91A-100ROM
R4175	-5-92	BB5625
R4176	-5-82	CB6205
R4177	-5-65	CB2405

REFERENCE DESIGNATION	FIG. & INDEX NO.	PART NUMBER
R4192	8 -5-52	CB1005
R4201	-4-17	CB5105
R4202	-6-27	BB1055
R4203	-6-26	CB5105
R4205	-4-72	CB5605
R4206	-4-68	91A-100ROM
R4208	-4-72	CB5605
R4209	-4-71	CB6815
R4222	-5-119	MFF1816G10003F
R4223	-5-77	CB4745
R4225	-5-52	CB1005
R4226	-5-62	CB2005
R4227	-5-62	CB2005
R4234	-5-48	91A-10001M
R4235	-5-55	CB1035
R4236	-5-60	CB1515
R4242	-5-68	CB3015
R4243/S4243	-4-96	381CM40934
R4244	-5-89	BB1225
R4245	-5-89	BB1225
R4246	-5-90	BB2025
R4247	-5-90	BB2025
R4253	-4-91	388-CM40915
R4254	-5-61	CB1825
R4256	-5-53	CB1015
R4260	-6-30	MFF1816G200ROD
R4261	-6-29	MFF186G150ROD
R4262	-6-25	CB1215
R4263	-5-120	MFF1816D400ROC
R4264	-6-32	MFF1816G800ROD
R4265	-6-30	MFF1816G200ROD
R4266	-6-29	MFF1816G150ROD
R4267	-6-24	91A-200ROM
R4268	-6-31	MFF1816G133R3D
R4269	-6-28	BB3005
R4271	-5-53	CB1015
R4272	-5-49	91A-5000M
R4275	-5-81	CB5625
R4276	-5-82	CB6205
R4280	-5-66	CB2415
R4281	-5-65	CB2405
R4282	-5-56	CB1215
R4283	-5-74	CB4315
R4284	-5-73	CB4305
R4285	-5-74	CB4315
R4286	-5-56	CB1215
R4287	-5-56	CB1215
R4288	-5-83	CB6215
R4289	-5-71	CB3615
R4290	-5-80	CB5605

AIR FORCE TO33A1-13-496-1
 NAVEX 0969-LP-170-0010
 Reference Designation Index

REFERENCE DESIGNATION	FIG. & INDEX NO.	PART NUMBER
R4291	8 -5-76	CB4715
R4292	-5-52	CB1005
R4312	-5-113	MFF1816G332ROF
R4313	-5-114	MFF1816G392ROF
R4314	-5-110	MFF1816G287ROF
R4317	-5-115	MFF1816G412ROF
R4318	-5-111	MFF1816G294ROF
R4322	-5-113	MFF1816G332ROF
R4323	-5-114	MFF1816G392ROF
R4324	-5-110	MFF1816G287ROF
R4327	-5-115	MFF1816G412ROF
R4328	-5-111	MFF1816G294ROF
R4333	-5-40	CB47G5
R4334	-5-67	CB2235
R4335	-5-84	CB6235
R4336	-5-57	CB1315
R4337	-5-54	CB1025
R4338	-5-85	CB6815
R4340	-5-96	MFF1816G38R30F
R4341	-5-103	MFF1816G80RG0F
R4343	-5-87	BB1005
R4345	-5-99	MFF1816G49R90F
R4349	-5-66	CB2415
R4351	-5-103	MFF1816G80R60F
R4355	-5-99	MFF1816G49R90F
R4356	-5-99	MFF1816G49R90F
R4359	-5-66	CB2415
R4361	-5-106	MFF1816G133ROF
R4362	-5-112	MFF1816G324ROF
R4363	-5-73	CB4305
R4364	-5-109	MFF1816G174ROF
R4365	-5-100	MFF1816G60R40F
R4366	-5-117	MFF1816G11000F
R4371	-5-106	MFF1816G133ROF
R4372	-5-112	MFF1816G324ROF
R4373	-5-73	CB4305
R4375	-5-100	MFF1816G60R40F
R4376	-5-98	MFF1816G41R20F
R4382	-5-107	MFF1816G150ROF
R4383	-5-53	CB1015
R4384	-5-75	CB4705
R4385	-5-83	CB6215
R4386	-5-60	CB1515
R4401	-5-102	MFF1816G75R00F
R4403	-5-102	MFF1816G75R00F
R4404	-5-58	CB1325
R4405	-5-78	CB5115
R4406	-5-47	91A-20001M
R4408	-5-59	CB1335
R4409	-5-64	CB2025

REFERENCE DESIGNATION	FIG. & INDEX NO.	PART NUMBER
R4410	8 -5-45	3329P-L58-101
R4411	-5-79	CB5125
R4413	-5-104	MFF1816G93R10F
R4414	-5-93	MFF1816G10R20F
R4416	-5-108	MFF1816G130ROF
R4418	-5-72	CB3625
R4419	-5-118	MFF1816G35702F
R4421	-5-110	MFF1816G287ROF
R4423	-5-86	CB8205
R4425	-5-69	CB3305
R4427	-5-101	MFF1816G66R50F
R4428	-5-116	MFF1816G511ROF
R4429	-5-114	MFF1816G392ROF
R4431	-5-110	MFF1816G287ROF
R4433	-5-86	CB8205
R4437	-5-101	MFF1816G66R50F
R4441	-5-88	BB1215
R4443	-5-46	3329P-L58-252
R4446	-5-105	MFF1816G110ROF
R4447	-5-44	3329P-L58-500
R4448	-5-95	MFF1816G30R10F
R4451	-5-88	BB1215
R4453	-5-74	CB4315
R4456	-5-105	MFF1816G110ROF
R4457	-5-97	MFF1816G39R20F
R4458	-5-95	MFF1816G30R10F
R4459	-5-94	MFF1816G12R70F
R4461	-5-80	CB5605
R4463	-5-62	CB2005
R4466	-5-43	NS2BB430ROF
R4471	-5-80	CB5605
R4473	-5-62	CB2005
R4474	-5-63	CB2015
R4475	-5-68	CB3015
R4476	-5-43	NS2BB430ROF
S500	-14-45	7101-J61-CB22
S700	-13-3	2DM301
S701	-13-68	260-1780-00
S702	-13-15	2074-L67-322
S2100	-8-9	214-2292-00
S2120	-8-10	214-2294-02
S2170	-8-11	260-1211-00
S2200	-8-9	214-2292-04
S2220	-8-10	214-2294-02
S2650	-11-10	260-1802-00
S2700	-10-4	2KA13010000
S2750	-11-11	260-1720-00
S2920	-10-3	260-1453-00
S3100	-7-46	263-1110-00
S3200	-7-46	263-1110-00

AIR FORCE TO33A1-13-496-1
 NAVELEX 0969-LP-170-0010
 Reference Designation Index

REFERENCE DESIGNATION	FIG. & INDEX NO.	PART NUMBER
S4100A	8 -4-80	105-0737-00
S4100B	-4-85	105-0738-00
S4200A	-4-80	105-0737-00
S4200B	-4-85	105-0738-00
S4240	-5-20	260-1445-01
S4330	-5-19	260-1424-01
S4378	-5-123	105-0423-00
S4380	-5-120	105-0421-00
T550	-14-5	120-0984-00
T700	-13-75	120-1095-00
T4335	-5-6	120-0384-00
U550	-14-38	152-0635-00
U722	-14-41	156-0158-00
U762	-14-40	156-0067-00
U2160	-8-7	155-0151-00
U2260	-8-7	155-0151-00
U2280	-8-8	156-0067-00
U2690	-11-8	155-0123-00
U2740	-11-9	156-0158-00
U2750	-11-7	155-0122-00

REFERENCE DESIGNATION	FIG. & INDEX NO.	PART NUMBER
U2790	8-11-8	155-0123-00
U2900	-10-2	155-0124-00
U4160	-5-18	155-0155-00
VR288	-14-28	1N965B
VR353	-14-25	152-0195-00
VR524	-14-25	152-0195-00
VR533	-14-32	1N983B
VR552	-14-30	1N991B
VR553	-14-37.1	1N968B
VR566	-14-29	1N989B
VR722	-14-34	1N937
VR725	-14-26	1N970B
VR736	-14-27	1N3034B
VR738	-14-28	1N965B
VR749	-14-31	1N3828A
VR769	-14-31	1N3828A
VR782	-14-39	1N957B
VR3128	-9-1	152-0217-00
V560	-12-15	154-0777-00

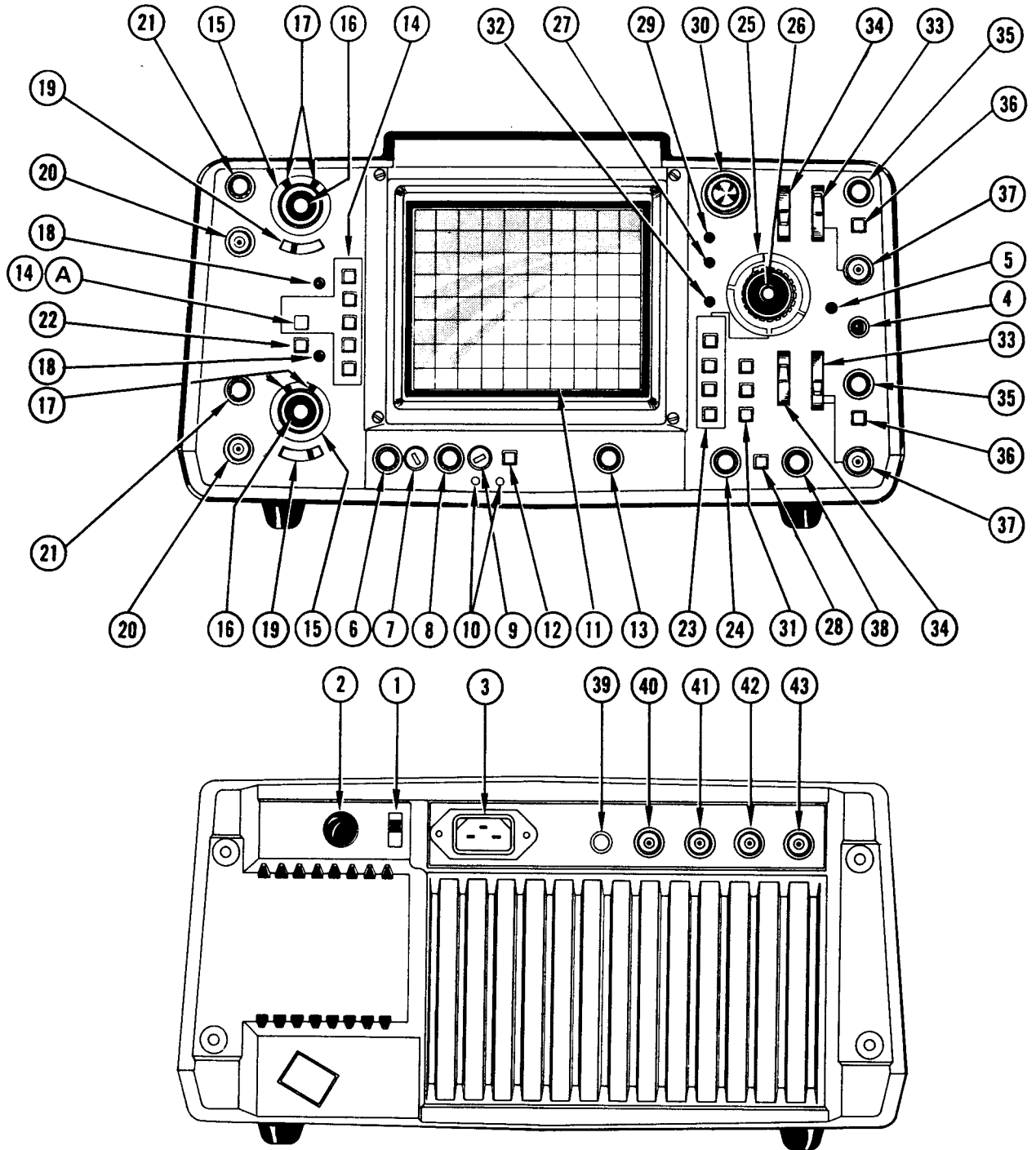

NOTE: CALLOUT NUMBERS ARE USED WITH TABLE 4-2

FO-1 (Front). Front and rear panel controls, connectors, and indicators.

