

TEKTRONIX®



INSTRUCTION MANUAL

Tektronix, Inc.
P.O. Box 500
Beaverton, Oregon 97077

Serial Number _____



WARRANTY

All Tektronix instruments are warranted against defective materials and workmanship for one year.

Any questions with respect to the warranty mentioned above should be taken up with your Tektronix Field Engineer.

Tektronix repair and replacement-part service is geared directly to the field, therefore all requests for repairs and replacement parts should be directed to the Tektronix Field Office or Representative in your area. This procedure will assure you the fastest possible service. Please include the instrument Type and Serial number with all requests for parts or service.

Specifications and price change privileges reserved.

Copyright © 1964 by Tektronix, Inc., Beaverton, Oregon. Printed in the United States of America. All rights reserved. Contents of this publication may not be reproduced in any form without permission of the copyright owner.



CONTENTS

	Warranty
Section 1	Characteristics
Section 2	Operating Instructions
Section 3	Circuit Description
Section 4	Maintenance
Section 5	Calibration
Section 6	Parts List and Diagrams

A list of abbreviations and symbols used in this manual will be found on page 6-1. Change information, if any, is located at the rear of the manual.



Type 547

Type 547 Oscilloscope

SECTION 1

CHARACTERISTICS

Introduction

The Type 547 Oscilloscope is a versatile laboratory instrument designed for use with all Tektronix lettered or 1-Series plug-in units. The instrument features two identical time-base generators that can be used singly or electronically alternated for viewing a single signal or multiple signals at two sweep rates.

The two time-base generators can also be used in "delaying" and "delayed" sweep operation for highly accurate time measurements.

Vertical Deflection System

Refer to Table 1-1 for the characteristics.

Sweep Generation

Trigger features and sweep rates of both Type 547 time-base circuits are identical.

Sweep Rates (at 1X magnification) 0.1 μ sec/cm to 5 sec/cm in 24 calibrated steps. Displayed Sweep-rate accuracy is $\pm 2\%$ for both sweeps. An uncalibrated variable sweep-rate control permits either sweep to be slowed to at least 0.4 of the indicated rate.

Sweep Magnification Any sweep rate can be increased by expanding the center portion of the display horizontally in fixed steps of 2X, 5X, and 10X. Sweep-rate accuracy is within $\pm 5\%$ in the magnified positions.

Trigger Source Selection Internal normal, internal plug in, external, and line.

Trigger Coupling Selection Dc, ac, and ac low-frequency rejection.

Trigger Signal Requirements Internal (ac): Minimum deflection is 2 mm, rising to 1 cm at about 50 mc.

TABLE 1-1
Plug-In Characteristics for the Type 547 Oscilloscope

Plug-In Unit	Calibrated Deflection Factor	Bandpass at -3 dB***	Fastest Risetime	Approx Input Capacitance
✕ Type 1A1**	50 mv/cm to 20 v/cm 5 mv/cm	dc to 50 mc dc to 28 mc	7 nsec 13 nsec	15 pf
Type 1A2	50 mv/cm to 20 v/cm	dc to 50 mc	7 nsec	15 pf
✕ Type 1A7	10 mv/cm to 10 v/cm	dc to 100 cps —500 kc	.7 μ sec	47 pf
Type 1S1	2 mv/cm to 200 mv/cm	dc to 1000 mc	.35 nsec	50 Ω input Z
Type B	0.005 v/cm to 20 v/cm 0.05 v/cm to 20 v/cm	2 cps to 12 mc dc to 20 mc	30 nsec 18 nsec	47 pf
Type CA**	0.05 v/cm to 20 v/cm	dc to 24 mc	15 nsec	20 pf
Type D	1 mv/cm to 50 v/cm	dc to 300 kc-2 mc	0.18 μ sec	47 pf
Type E	50 μ v/cm to 10 mv/cm	0.06 cps to 20 kc —60 kc	6 μ sec	50 pf
Type G	0.05 v/cm to 20 v/cm	dc to 20 mc	18 nsec	47 pf
Type H	5 mv/cm to 20 v/cm	dc to 15 mc	24 nsec	47 pf
Type K	0.05 v/cm to 20 v/cm	dc to 30 mc	12 nsec	20 pf
Type L	5 mv/cm to 2 v/cm 0.05 v/cm to 20 v/cm	3 cps to 24 mc dc to 30 mc	15 nsec 12 nsec	20 pf
Type M**	0.02 v/cm to 10 v/cm	dc to 20 mc	18 nsec	47 pf
Type O*	0.05 v/cm to 20 v/cm	dc to 25 mc	14 nsec	47 pf
Type Q*	10 μ strain/cm to 10,000 μ strain/cm	dc to 6 kc	60 μ sec	Adjustable
Type R*	0.5 ma/cm to 100 ma/cm			
Type S*	0.05 v/cm and 0.5 v/cm			
✕ Type W	1 mv/cm to 50 v/cm	dc to 8 mc dc to 23 mc	44 nsec 16 nsec	20 pf
Type Z*	0.05 v/cm to 25 v/cm	dc to 13 mc	27 nsec	24 pf

*Special feature plug-in units. See your Tektronix catalog for more information on any of these plug-in units.

**Multiple-trace plug-in units.

***Not more than -3 dB at indicated frequencies.

Characteristics—Type 547/RM547

Internal (dc): Minimum deflection is 5 mm at dc rising to 2.5 cm at 50 MHz.

Internal (ac low-frequency rejection): Minimum deflection is 2 mm with signals at about 2 kc, rising to 1 cm at about 50 mc.

External: Frequency ranges are the same as internal. Minimum amplitude is 200 mvolts peak-to-peak (ac), 200 mvolts change in dc level (dc) and, 200 mvolts peak-to-peak (ac low-frequency reject). A MAXIMUM INPUT OF ± 30 VOLTS must not be exceeded in the EXTERNAL trigger position. Minimum trigger level range is greater than ± 2 volts with the TRIGGER LEVEL control pushed in and ± 20 volts with the control pulled out.

Sweep Delay The time-base A sweep can be delayed by the main time base (B) sweep. Delay is continuously variable over the range of 0.1 μ sec to 50 sec with the DELAY TIME and DELAY-TIME MULTIPLIER controls. Delay time is accurate to $\pm 1\%$ of indicated delay ± 2 minor divisions of the DELAY-TIME MULTIPLIER at sweep rates from 50 μ sec to 50 sec. At delay times shorter than 50 μ sec, indicated delay accuracy is the same as above plus approximately 75-100 nsec. The 75-100 nsec represents the fixed inherent delay of the internal trigger circuitry of the Type 547. Incremental delay accuracy is ± 4 minor divisions of the DELAY-TIME MULTIPLIER dial at sweep rates from 1 μ sec to 50 sec. Incremental accuracy at the three fastest sweep rates (0.1, 0.2, and 0.5 μ sec) is ± 10 minor divisions. Stated accuracies apply only when the VARIABLE controls are set to CALIB. Delay jitter is no greater than 1 part in 20,000.

Horizontal Deflection System

The following characteristics apply when the HORIZONTAL DISPLAY switch is set to the EXT positions.

Deflection Factor	Continuously variable from approximately 0.1 volt/cm to 10 volts/cm.
Frequency Response	Dc to 400 kc (3-db down).
Input Characteristics	1 megohm paralleled by approximately 55 pf.

Amplitude Calibrator

Output Voltages	0.2 mvolts to 100 volts peak-to-peak in 18 steps. In addition, a 100-volt dc output is available.
Frequency	Approximately 1-kc square wave.
Output Current	5 ma square wave available at the front-panel current loop.

Output Impedance	50 Ω in .2 to 200 mVOLTS positions. Progressively higher output impedances in the .5 to 50 VOLT positions up to about 4 k in the 50 VOLT position. Output impedance of the 100 VOLT position (ac and dc) is about 420 Ω .
------------------	---

Amplitude Accuracy	Peak-to-peak amplitude accuracy is $\pm 3\%$ of indicated value when working into an impedance of 1 megohm. The .2 to 200 mVolts position will be within $\pm 3\%$ of one-half of the indicated voltage when working into an impedance of 50 ohms. The 5 ma current accuracy is $\pm 3\%$.
--------------------	---

Front-Panel Output Signals

+GATE B	Approximately 20-volt peak-to-peak square-wave pulse having the same duration as the B sweep. Minimum dc load resistance is 5 k.
DLY'D TRIG	Approximately a 10-volt peak-to-peak pulse occurring at the end of the delay period.
SWEEP A	Approximately a 90-volt, peak-to-peak sawtooth voltage having the same duration as the A sweep. Minimum load impedance is 10 k.
+GATE A	Approximately 20-volt peak-to-peak square-wave pulse having the same duration as the A sweep. Minimum dc load resistance is 5 k.
VERT SIG OUT	Vertical signal output connector. Output amplitude is approximately 0.3 volt per centimeter of deflection on the crt. Rise-time is 20 nsec or faster. Output is ac coupled.
External Single-Sweep Reset Input-Signal Requirements	Requires a positive-going step or pulse of at least +20 volts with a risetime of 0.5 μ sec or faster.

Cathode-Ray Tube

Type	T5470-31-2
Unblanking	Dc coupled.
Accelerating Potential	10 kv.
Usable Viewing Area	6-cm high by 10-cm wide.
Focus	Vertical: 2 horizontal lines/mm distinguishable over the center 4 cm. 1.5 horizontal lines/mm distinguishable in the top and bottom 1 cm. Horizontal: 2 time markers/mm distinguishable over the middle 8 cm. 1.5 time markers/mm distinguishable in the first and tenth cm.

Characteristics—Type 547/RM547

Graticule Internal, adjustable edge lighting. 6X10 cm with vertical and horizontal 1-cm divisions with 2-mm markings on the centerlines. Provision made for risetime measurement.

Power Supplies

Line Voltage $\pm 10\%$ of nominal line voltage. (See Operating Instructions)

Line Frequency 50-60 and 400 cps.*

Power Consumption 510 watts typical.

Mechanical

Construction Front panel is anodized. Chassis is aluminum alloy.

Dimensions See Dimension Drawing.

*With line frequencies other than 50-60 cycles, a special fan modification is required; contact your local Tektronix Field Representative.

SECTION 2

OPERATING INSTRUCTIONS

FUNCTION OF CONTROLS AND CONNECTORS

NOTE

The Time Base A and Main Time Base (B) controls serve identical functions with the exception of the BRIGHTNESS control.

TRIGGERING LEVEL	Selects the amplitude point on the triggering signal where sweep-triggering occurs. When the knob is pulled out, greater triggering range is offered for triggering on higher amplitude signals. The triggering circuit is most sensitive to small signals with the TRIGGERING LEVEL control pushed in and set to 0.	BRIGHTNESS	Allows adjustment of the contrast or brightness ratio of the B trace compared to the A trace.
TRIGGERING MODE	<p>AUTO STABILITY position permits normal triggering on signals with repetition rates higher than about 20 cps. With no trigger signal, or with a lower repetition rate, the time-base circuit free runs and provides a handy reference trace.</p> <p>TRIG (triggered) position permits normal triggering on all triggering signals. No trace occurs when the triggering signal is removed.</p>	HORIZONTAL DISPLAY	<p>The A position allows only Time Base A to display on the crt.</p> <p>The ALT position, at the top permits alternate operation so that both time bases are displayed independently. The B position allows only the Main Time Base (B) to display on the crt.</p> <p>B INTENS BY 'A' is one of the delayed-sweep functions. In this position, a portion of the Main Time Base (B) is intensified during the time that Time Base A (the delayed sweep) is in operation.</p> <p>The ALT position on the right-hand side permits alternate operation and display of both time bases while using the delayed-sweep feature. This allows the operator to view both the delaying sweep (Main Time Base) and the delayed sweep (Time Base A).</p> <p>A DLY'D is one of the delayed sweep functions. In this position Time Base A is displayed at the end of each delay period as determined by the B TIME/CM or DELAY TIME and DELAY-TIME MULTIPLIER controls.</p> <p>EXT X1 and X10 positions permit an external signal to be applied to the horizontal deflection circuit. Sensitivity is continuously variable (with the VAR 10-1 control).</p>
SLOPE	Determines whether the time base is triggered on the negative- (—) or positive- (+) going slope of the signal.	READY Lamps	These light when the corresponding time-base circuit is ready for triggering.
COUPLING	<p>AC position blocks the dc component of the triggering signal and allows triggering to take place only on the changing portion of the signal. With frequencies below about 30 cps, use the DC position.</p> <p>AC LF REJ position attenuates trigger signal frequencies below about 1.5 kc, allowing the trigger circuits to respond only to higher frequencies.</p> <p>DC position permits triggering on both high- and low- (to dc) frequency signals.</p>	SWEEP MAGNIFIER	Expands the sweep from the center of the graticule at any setting of the TIME/CM switch by the amount indicated.
SOURCE	<p>INT NORM position uses a portion of the signal applied to the vertical deflection plates of the crt as a trigger signal.</p> <p>INT PLUG IN position applies to multi-trace plug-in units that provide a single-channel trigger signal through pin 5 of the interconnecting plug (e.g. Tektronix Type 1A1 plug-in unit).</p> <p>LINE position uses a line-frequency signal as a trigger.</p> <p>EXT position is for external triggering on a signal applied to the TRIGGER INPUT connector.</p>	SINGLE SWEEP	Permits single-sweep operation in all modes of horizontal display except EXT.
TIME/CM	Selects the sweep rate of Time Base A.	DELAY-TIME MULTIPLIER 1-10	Works in conjunction with the TIME/CM or DELAY TIME control of the Main Time Base (B). Varies sweep delay from 0.15 to 10.15 times the rate indicated by the Main Time Base (B) TIME/CM or DELAY TIME switch.
VARIABLE	Provides an uncalibrated adjustment of sweep rate. The sweep rate can be	HORIZONTAL POSITION VERNIER	Positions the display along the horizontal axis of the crt.
		AMPLITUDE CALIBRATOR	Determines the peak-to-peak voltage available at the CAL OUT connector.

Operating Instructions—Type 547/RM547

5 mA Current Loop	Provides a calibrated source of square-wave current. The arrow shows direction of conventional current flow (i.e. positive to negative).
POWER	Toggle switch for turning the instrument on and off.
INTENSITY	Controls brightness of the display (all traces).
FOCUS	Used in conjunction with the INTENSITY and ASTIGMATISM controls for obtaining a well-defined display.
ASTIGMATISM	Used in conjunction with the INTENSITY and FOCUS controls for obtaining a well-defined display.
TRACE ROTATION	Permits horizontal alignment of the trace with respect to the horizontal lines of the graticule.
SCALE ILLUM	Varies illumination of the grid lines of the graticule.
TRACE SEPARATION	Varies the vertical position of the Time Base A trace when the HORIZONTAL DISPLAY switch is set to either ALT position.
Beam Position	Four neon lamps with accompanying arrows indicate the direction when the display is deflected out of the viewing area.
TRIGGER INPUT (Time Base A)	Connector for applying an external trigger signal to Time Base A when its SOURCE switch is set to EXT.
TRIGGER INPUT (Main Time Base (B))	Connector for applying an external trigger signal to the Main Time Base (B) when its SOURCE switch is set to EXT.

CAUTION

A MAXIMUM INPUT OF ± 30 VOLTS MUST NOT BE EXCEEDED IN THE EXTERNAL TRIGGER POSITION.

HORIZ INPUT	Jack for applying external horizontal signal when the HORIZONTAL DISPLAY switch is set to either X1 or X10 EXT.
+GATE B	Supplies a 20-30-volt square-wave pulse when the Main Time Base (B) is operating. Pulse duration is approximately 10.5X the setting of the TIME/CM or DELAY TIME switch when the VARIABLE control is set to CALIBRATED.
DLY'D TRIG	Supplies a sharp positive-going trigger spike of about 10 volts at the end of the delay period as set by the TIME/CM or DELAY TIME switch and the DELAY-TIME MULTIPLIER control.
SWEEP A	Supplies the sawtooth voltage of Time Base A. Peak amplitude is about +10 volts.
+GATE A	Same as +GATE B except applies to Time Base A.
VERT SIG OUT	Vertical signal output connector. Output amplitude is approximately 0.3 volt per centimeter of deflection.

Chopped Blanking Switch (rear panel)	Provides blanking of between-channel switching transients when using multi-channel plug-in units in the chopped mode.
External Single Sweep Reset (rear panel)	Allows remote control of resetting in single-sweep operation. See Section 1 for reset step or pulse requirements.
EXTERNAL DELAY INPUT (rear panel)	A four-pin connector is provided for an external delay generator (rather than the normal internal delay produced by the B sweep). Pin A of the connector permits disabling of the normal internal delayed trigger and is the feed-in point for the external delay trigger (see Fig. 2-1). Pin B is normally dc open and ac ground (through a 0.01 μ f capacitor), except in the B INTENS BY 'A' and ALT (between B INTENS BY 'A' and A DLY'D) positions of the HORIZONTAL DISPLAY switch, then it is dc ground. Pin C supplies a B-gate pulse. Pulse characteristics are: +2 volts minimum with a risetime of 50 nsec or faster into a load of 1.1 k paralleled by 100 pf. Duration of the pulse is the same as the length of the B sweep. Pin D is ground at all times.

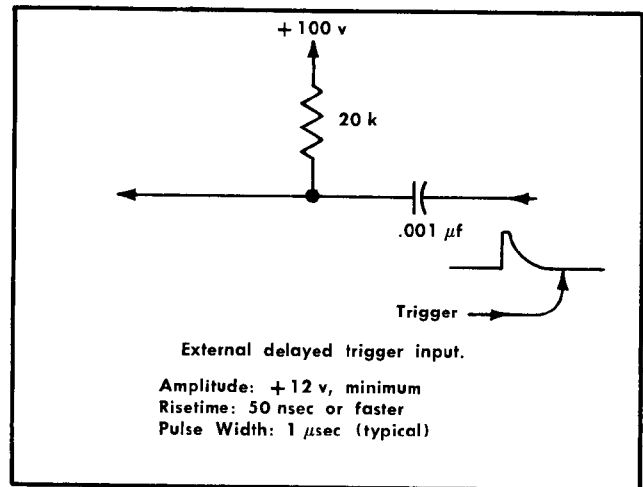

Fig. 2-1. Method of coupling an external delayed trigger into the Type 547.

NORMAL (NONDELAYED) SWEEP

The Type 547 Oscilloscope features two independent time-base circuits: Time Base A and the Main Time Base (B). The time bases can be used singly or alternately. When used alternately, an input signal can be displayed at two different sweep rates in two independent presentations.

Sweep Triggering

Proper sweep triggering is essential for a stable presentation of an input signal. For a stable display, the sweep must be triggered at the same time relative to the displayed signal. Thus, the sweep must be triggered by the input

signal or by some external signal that has a fixed time relationship with the displayed signal. The external trigger signal must be the same frequency or a submultiple of the input signal.

In alternate-sweep operation, both sweeps must be triggered to obtain a display. The ready lights may be used to determine the proper triggering sequence.

Selecting the Trigger Source

The SOURCE switch selects one of a variety of possible triggering signals. For most applications, the sweep can be triggered internally from the displayed signal. This occurs with the SOURCE switch set at NORM.

The PLUG-IN position is for plug-in units that will supply a single-channel triggering signal through pin 5 of the interconnecting plug, such as the Tektronix Type 1A1 Dual-Trace Plug-In Unit. This position is useful when operating the plug-in unit in dual-trace chopped-mode operation since the triggering signal is the same as the applied signal and is free from any between-channel switching transients.

The LINE position of the SOURCE switch connects a line-frequency signal to the triggering input. Line triggering is useful whenever the input signal is frequency-related to the line frequency.

To trigger the time base from an external signal, set the SOURCE switch to EXT and connect the trigger signal to the TRIGGER INPUT connector. External triggering is often used when signal tracing in amplifiers, phase-shift networks, and wave shaping circuits. The signal from a single point in the circuit can be used as the external trigger signal. With this arrangement, it is possible to observe the shaping and/or amplification of a signal at various points through the circuit without resetting the triggering controls for each new display.

Selecting Trigger Coupling

Three means of trigger coupling are available with the COUPLING switch. The different coupling positions permit you to accept or reject certain frequency components of the triggering signal.

With the COUPLING switch set at DC, the time base can be triggered with all frequency components of the triggering signal within the trigger amplifier bandpass, including dc levels.

With the COUPLING switch set at AC, the dc component of the triggering signal is blocked. Also, low-frequency signals below about 30 cps are attenuated.

With the COUPLING switch set at AC LF REJ, dc and low-frequency signals (below about 1.5 kc) are rejected or attenuated. Thus, the trigger circuit will respond best to the higher-frequency components of the triggering signal.

In general, use AC coupling. However, it will be necessary to use DC coupling for very low-frequency signals. When line-frequency hum is mixed with the triggering signal, it is best to use AC LF REJ coupling so that triggering takes place only on the signal of interest (if the signal of interest contains frequency components above about 1.5 kc).

The AC LF REJ position is also useful when triggering internally from multitrace plug-in units operated in the alternate dual-trace mode (unless the plug-in unit is a Type 1A1 and the SOURCE switch is set to PLUG IN). AC LF REJ coupling has a faster recovery time when subjected to the alternate dc levels from the multitrace plug-in unit.

Selecting Trigger Slope

The trigger SLOPE switch determines whether the triggering circuit responds on the rising (+ setting) or the falling (— setting) portion of the triggering signal. When several cycles of a signal appear in the display, the setting of the SLOPE switch will probably be unimportant. However, if you wish to look at only a certain portion of a cycle, the SLOPE switch will help start the display on the desired slope of the input signal. Fig. 2-2 illustrates the effect of both the SLOPE and TRIGGERING LEVEL controls.

Selecting Trigger Mode

The automatic stability mode is generally more convenient. With the MODE switch set to AUTO STABILITY, proper triggering takes place after setting the TRIGGERING LEVEL control. When the triggering signal is removed, the time-base circuit automatically free runs and presents a reference display. In alternate sweep operation, both MODE switches should be set to AUTO STABILITY. If this is done, a display will be maintained if one of the triggering signals is removed.

The TRIG position of the MODE switch should be used if the trigger signal has a very low repetition rate (below about 20 cps).

Setting Triggering Level

The TRIGGERING LEVEL control determines the amplitude point on the signal where triggering occurs.

The trigger circuit is most sensitive to ac triggering signals with the TRIGGERING LEVEL control set near zero and pushed in. Moving the TRIGGERING LEVEL control in the + direction causes the trigger circuit to respond at some higher positive amplitude on the triggering signal. Moving the TRIGGERING LEVEL control in the — direction causes the trigger circuit to respond at some higher negative amplitude on the triggering signal. Fig. 2-2 illustrates the effect of the TRIGGERING LEVEL control and the SLOPE switch.

The range of the TRIGGERING LEVEL control is extended 10 times when pulled out.

Selecting Time/Cm (Sweep Rate)

The TIME/CM and SWEEP MAGNIFIER switches control sweep rate. The SWEEP MAGNIFIER switch expands both time bases.

The TIME/CM and SWEEP MAGNIFIER switches allow you to view an applied signal at a wide variety of calibrated sweep rates. When you make time measurements from the crt, be sure the VARIABLE control is set to CALIBRATED.

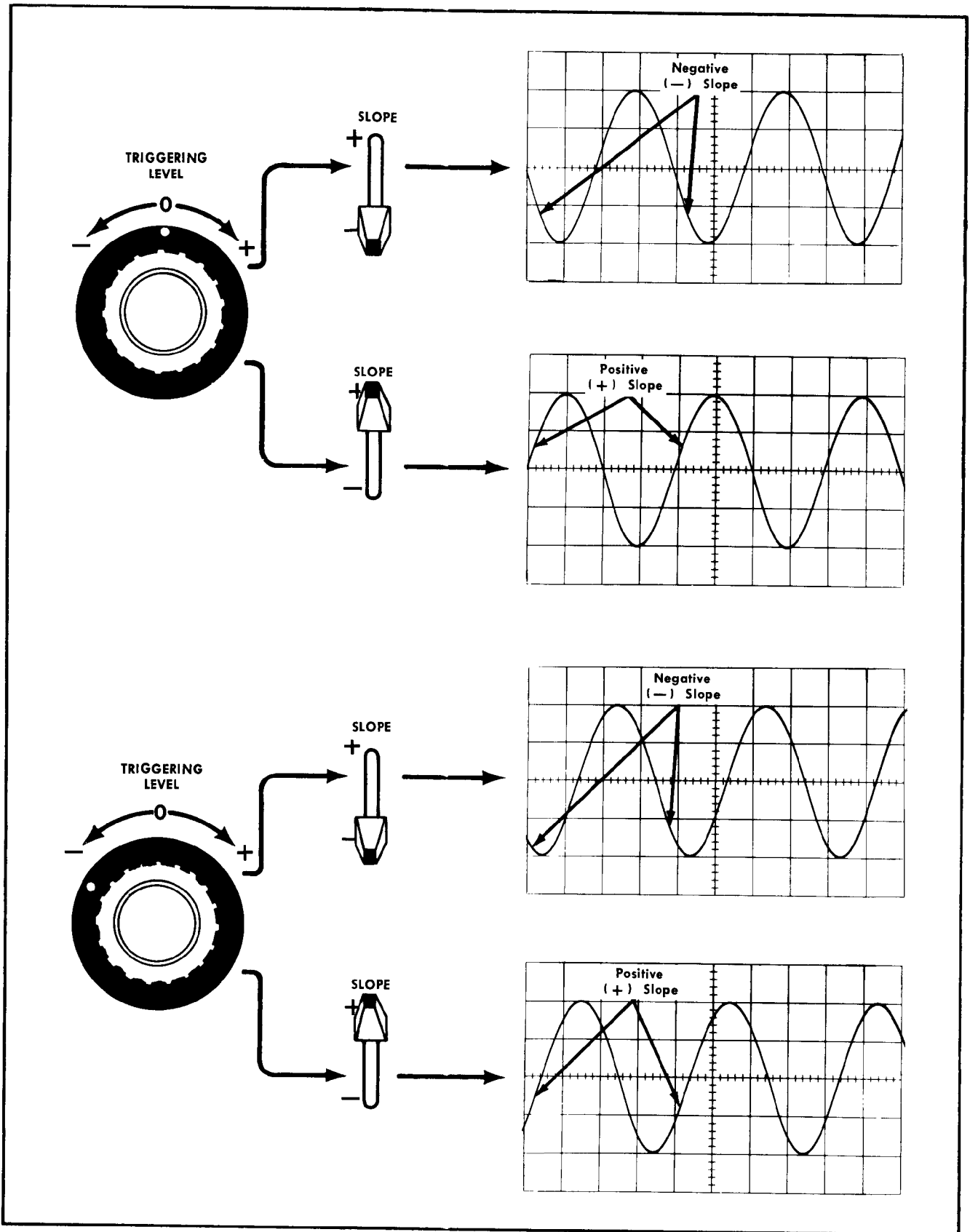

Fig. 2-2. Effects of the TRIGGERING LEVEL and SLOPE controls.

When the SWEEP MAGNIFIER switch is set to X1, the TIME/CM switch indicates the true sweep rate. However, with the SWEEP MAGNIFIER switch set to X2, the setting of the TIME/CM switch must be divided by 2 to determine the true sweep rate. For example, assume that the TIME/CM switch is set at 1 mSEC and the SWEEP MAGNIFIER is set to X5. In this case, the true sweep rate would be 1 (msec) divided by 5 (SWEEP MAGNIFIER setting); resulting in a displayed sweep rate of 0.2msec per division. Fig. 2-3 illustrates how to make time measurements from the graticule.

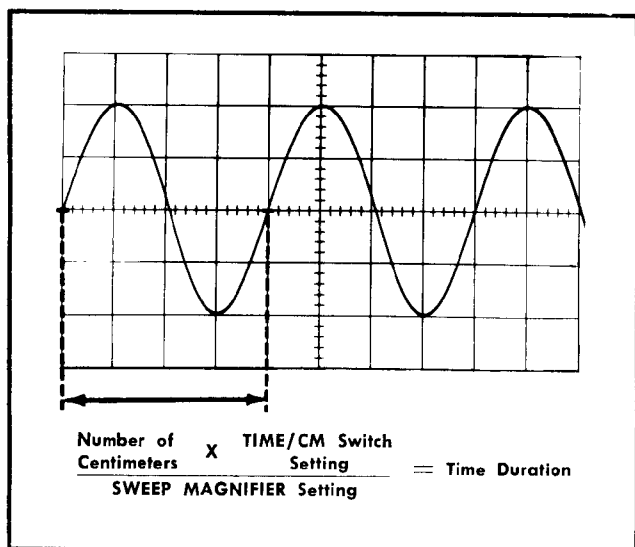

Fig. 2-3. Illustration of time measurement from the graticule.

Alternate-Sweep Operation

Alternate-sweep operation occurs with the HORIZONTAL DISPLAY switch set to one of the ALT positions. The alternate-sweep features of the Type 547 allow signal to be displayed at two independent sweep rates. The alternate-sweep features can be used in either delayed or nondelayed modes of operation.

To obtain a display in the alternate-sweep mode, both time-base circuits must be triggered. To insure that both time-base circuits are always triggered, the MODE switch of both Time Bases can be set to AUTO STABILITY. If this is done, the oscilloscope presents an alternate-sweep display even if there is no triggering signal or if the TRIGGERING LEVEL control is set improperly.

With a Tektronix Type 1A1 Dual-Trace Plug-In Unit operating in the alternate dual-trace mode, Channel 1 will lock-in with the Time Base A sweep, and Channel 2 will lock-in with the Main Time Base (B) sweep. The result is two displays that are independent in sweep rate and vertical deflection factor. If a multitrace plug-in unit is operated in the chopped mode, each channel will be displayed on both time bases.

The TRACE SEPARATION control allows vertical positioning of the Time Base A display in either ALT mode. The vertical position control of the plug-in unit positions both

displays. The BRIGHTNESS control varies the intensity of the Main Time Base (B) trace. This adjusts brightness or contrast ratio of the B trace compared to A trace. In the delayed mode, this allows the operator to adjust the intensified zone on the delaying sweep for best viewing contrast. In the normal alternate mode the operator may adjust the brightness level so that the intensity of each sweep is equal while the sweep rates may be significantly different. Also, the BRIGHTNESS control provides a convenient means of identifying the Main Time Base (B) trace when both traces are displayed on the crt.

Single-Sweep Operation

In applications where the displayed signal is not repetitive or varies in amplitude, shape, or time, a conventional repetitive display may produce a jumbled presentation. To avoid this, use the single-sweep feature of the Type 547. To use single sweep, first make sure the trigger circuit will trigger on the event you wish to display. Do this in the conventional manner with the single sweep switch set to NORMAL. Then, depress the single sweep switch to the RESET position and release the switch so it returns to the SINGLE SWEEP position. When this is completed, the next trigger pulse will actuate the sweep and the instrument will display the event on a single trace. The READY lamps, near the HORIZONTAL DISPLAY switch, first light when the sweep is ready to accept a trigger and then go out after triggering has taken place. To ready the circuit for another single display, depress the single sweep switch to RESET and release. In single-sweep operation, make sure the MODE switch is set to TRIG.

In normal alternate mode, the single sweep switch controls the B sweep. Thus, the A sweep can run up only once after the B sweep has occurred due to the alternating function. Therefore, for each single-sweep reset, each time base produces a single alternate sweep upon being triggered.

In the delayed alternate mode, the single-sweep switch again controls only the B sweep. However, B sweep must run up for each display. Therefore, resetting is required for each display.

NONTRIGGERED DELAYED SWEEP

The following procedures describe various measurements, the accuracy of those measurements, and other operations that can be performed using delayed sweep.

Insert a vertical plug-in unit and set the controls and switches on the instruments as listed in Table 2-1.

Set the HORIZONTAL POSITION control so the trace begins precisely at the left-hand edge of the graticule. Notice the position of the intensified segment in the trace.

Now set the B TIME/CM or DELAY TIME switch to .2 SEC and A TIME/CM to 20 mSEC. The intensified segment should be at the same position as with the previous sweep rates.

Connect the SWEEP A output to the vertical plug-in unit input. Notice that the A sweep sawtooth and the intensified segment in the trace start and end at the same time. This display shows that time base A produces one sweep during the intensified segment of each B sweep. The A TRIGGERING LEVEL control has no effect.

Operating Instructions—Type 547/RM547

The B sweep rate is 0.2 sec/cm. The intensified segment begins 5 cm after the beginning of the trace. Hence, the A sweep starts 1 sec after the B sweep (0.2 sec/cm \times 5 cm).

The number of centimeters between the beginning of the trace and the beginning of the intensified segment is established by the setting of the DELAY-TIME MULTIPLIER control. Therefore, with any dial setting, the time difference between the beginning of the A and B sweeps is the product of the B TIME/CM or DELAY TIME switch and the DELAY-TIME MULTIPLIER dial setting (see Fig. 2-4).

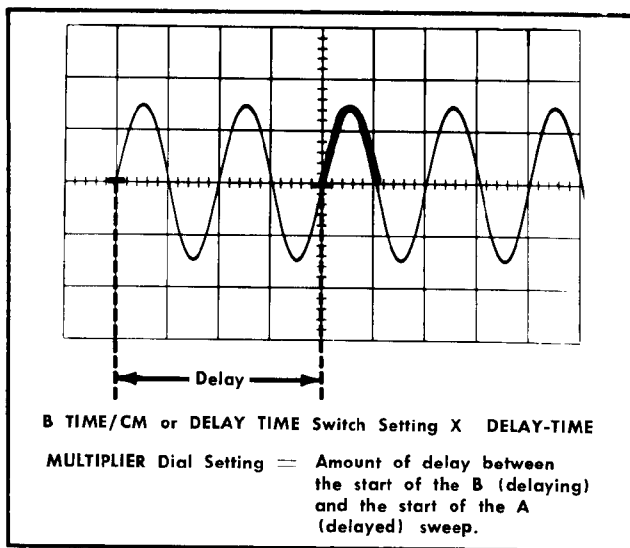

Fig. 2-4. Determining delay time.

TABLE 2-1

B MODE	AUTO STABILITY
B SOURCE	NORM
B COUPLING	AC
B SLOPE	+
B TRIGGERING LEVEL	0
B TIME/CM or DELAY TIME	1 mSEC
A MODE	AUTO STABILITY
A SOURCE	EXT
A TIME/CM	.1 mSEC
VARIABLE (A and B)	CALIBRATED
HORIZONTAL DISPLAY	B INTENS BY 'A'
SWEEP MAGNIFIER	OFF (\times 1)
DELAY-TIME MULTIPLIER	5.00
AMPLITUDE CALIBRATOR	10 Volts

HORIZONTAL POSITION	Centered
INTENSITY	So both intensity levels in the trace are easily seen.

Set the applicable controls and switches of the vertical plug-in unit as follows:

VOLTS/DIV	5
VARIABLE	CALIBRATED
AC-DC-GND	DC
POSITION	Trace centered.

The following procedures describe five common applications of the delayed-sweep feature. These applications are more accurate than time measurements taken directly from the crt display.

Demonstration 1

This procedure describes how to measure pulse duration with the pulse triggering the Main Time Base (B).

Set the controls and switches as listed in Table 2-1 except as follows:

B TIME/CM or DELAY TIME	.1 mSEC
A TIME/CM	1 μ SEC

Apply the AMPLITUDE CALIBRATOR signal to the input of the vertical plug-in unit. If necessary, adjust B TRIGGERING LEVEL to obtain a stable display. The display should consist of nearly 1 cycle of the square-wave signal.

Set the DELAY-TIME MULTIPLIER dial to intensify the falling portion of the square wave. Set the HORIZONTAL DISPLAY switch to A DLY'D. The display should now be a horizontally expanded version of the signal observed in the intensified segment of the previous display. Set the HORIZONTAL DISPLAY switch to ALT (between the B INTENS BY 'A' and A DLY'D positions). Now, both the "delaying" and the "delayed" sweeps can be observed simultaneously. Adjust the BRIGHTNESS control of the Main Time Base (B) to equalize the intensity. Set the TRACE SEPARATION control so that the 0 and 100% amplitude points of both displays are exactly superimposed.

Set the DELAY-TIME MULTIPLIER dial so the falling 50% point on the delayed trace exactly crosses the 50% amplitude level on the rising portion of the intensified display (this point may be hard to see but will be very near the start of both traces). Multiply the DELAY-TIME MULTIPLIER dial reading (e.g. 5.03) by the B TIME/CM or DELAY TIME switch setting. The product is the time duration of the square-wave positive-going half-cycle.

Accuracy: Determined by the combination of all the following factors:

1. The basic accuracy of time measurements made by using the sweep delay is as stated in Section 1.
2. The Delay Pickoff and Time Base A generator circuits typically require a net total of about 75 to 100 nsec to respond to the signal event which triggers Delayed Sweep

(A). This small inherent delay need not be considered unless it is a significant percentage (delay times shorter than 50 μ sec) of the measured time or when measuring time differences using the same sweep rate. When necessary, add the net circuit delay time to the measured time; that is, when measuring the time from the start of the B sweep.

Summary: The method described in Demonstration 1 provides a time measurement accuracy within 1% of reading ± 2 minor divisions of the DELAY-TIME MULTIPLIER dial.

By comparing the delay reading to an accurate external timing standard (such as a Tektronix Type 180A Time-Mark Generator) and applying a correction factor, an accuracy of ± 2 minor divisions of the DELAY-TIME MULTIPLIER dial can be achieved.

Demonstration 2

This procedure describes how to measure time between two pulses, neither of which triggers Time Base A.

Set the controls and switches as listed in Table 2-1 except as follows:

B TIME/CM or DELAY TIME	2 mSEC
A TIME/CM	2 μ SEC

Apply the AMPLITUDE CALIBRATOR signal to the vertical input. If necessary, adjust the B TRIGGERING LEVEL control to obtain a stable display. The display should consist of about 2 cycles of the square wave. Set the DELAY-TIME MULTIPLIER dial so the square-wave rise located near the center of the display is intensified.

Set the HORIZONTAL DISPLAY switch to ALT (between the B INTENS BY 'A' and A DLY'D positions). The display should now include a horizontally expanded version of the intensified segment.

Set the DELAY-TIME MULTIPLIER dial so the rising 50% amplitude level of the square wave intersects the vertical centerline of the graticule. Note the exact setting of the DELAY-TIME MULTIPLIER dial (e.g. 5.48). Turn the DELAY-TIME MULTIPLIER dial clockwise until the falling 50% amplitude level of the square wave intersects the same vertical graticule centerline used with the previous dial setting. Again note the exact setting of the DELAY-TIME MULTIPLIER dial.

Subtract the first dial setting from the second setting. The product of the difference times the B TIME/CM or DELAY TIME switch setting equals the time duration of the square-wave positive-going half-cycle (between the 50% amplitude points). This measurement should indicate a time of about 0.5 msec.

Accuracy: Determined by the combination of the following factors:

1. The basic accuracy of the sweep delay as described in Demonstration 1.

2. The error added by the sweep-delay system linearity is ± 4 minor dial divisions. Hence, % of measurement error decreases as the numerical dial difference increases.

NOTE

When the separation between dial settings is 100 minor dial divisions or less, the time measurement can often be made more accurate by direct reading from a magnified crt display. See Demonstration 3: Magnification.

3. The accuracy of time measurements made in Demonstration 2 is independent of the inherent circuit delays, provided the B TRIGGERING LEVEL control setting is the same for each of the two dial readings.

Summary: The method described in Demonstration 2, provides time measurement accuracy as stated in Section 1. Accuracy will be greatest when the numerical difference between the two DELAY-TIME MULTIPLIED readings is greatest.

Demonstration 3

Complex signals contain a number of individual events of different amplitudes. Since the trigger circuits of the Type 547 respond to signal amplitude, a stable display will normally be obtained only when the sweep is triggered by the event having the greatest amplitude. The A delayed mode permits the start of the A sweep to be delayed for a selected time after the signal event having the greatest amplitude. Any event within the series of events may then be displayed in magnified form as follows:

Set the controls and switches on the instrument as listed in Table 2-1. Apply the AMPLITUDE CALIBRATOR signal to the vertical input. If necessary, adjust the B TRIGGERING LEVEL control to obtain a stable display. The display should consist of several cycles of the square-wave signal. Set the DELAY-TIME MULTIPLIER dial to intensify one of the positive-going pulses.

Set the HORIZONTAL DISPLAY switch to ALT (between the B INTENS BY 'A' and A DLY'D positions). The display should now include the same signal information as the intensified trace segment, but horizontally expanded (magnified) ten times.

Increase the A sweep rate to 1 μ sec/div. The BRIGHTNESS and INTENSITY controls may require readjustment to view both displays. Set the DELAY-TIME MULTIPLIER dial to position a square-wave rise on the crt. The display now gives $\times 1000$ magnification of the intensified segment.

Slowly turn the DELAY-TIME MULTIPLIER dial. Note that any portion of the square wave can be brought into view in magnified form.

The DELAY-TIME MULTIPLIER dial reading corresponds to the number of centimeters between the beginning of the time base B trace and the beginning of the time base A (intensified) trace (e.g. 7.00 = 7 major graticule divisions).

Operating Instructions—Type 547/RM547

The A delayed display will probably exhibit some horizontal jitter. The time jitter contributed by the delay system is less than 5×10^{-5} times the B TIME/CM or DELAY TIME switch setting. Since the sweep rate of the delayed sweep is now $1 \mu\text{sec/cm}$, the jitter due to the delay system is less than one-half centimeter.

Accuracy: Depends solely on the B sweep-rate accuracy as listed in Section 1.

Demonstration 4

Ordinarily, the displayed signal is also used to trigger the oscilloscope sweep. In some situations, it may be desirable to reverse this situation. The sweep-related output pulses, available from the front-panel of the Type 547, can be used as a triggering signal for an external device. The output signal of the external device can then produce a stable display while the oscilloscope sweep free runs.

To demonstrate one method of performing this operation, proceed as follows:

Set the controls and switches as listed in Table 2-1 except as follows:

B SOURCE	EXT
DELAY-TIME MULTIPLIER	1.00
B TIME/CM or DELAY TIME	$10 \mu\text{SEC}$
A TIME/CM	$1 \mu\text{SEC}$

Connect a lead from the DLY'D TRIG connector to the vertical input. The display should consist of a positive-going spike.

The oscilloscope display is the pulse that is available at the Type 547 at the end of each delay period. In a practical application, the pulse would not be applied to the vertical input but instead to some external device to be tested. The pulse would then serve as the trigger pulse or input signal for the external device, and the output of the device would provide a stable display on the oscilloscope, as through the oscilloscope were triggered in the normal manner.

Demonstration 5

The +GATE A connector output signal of the Type 547 can be used as a variable repetition rate, variable duty-factor pulse generator. To use the Type 547 in this manner, proceed as follows:

Set the controls and switches as listed in Table 2-1 except as follows:

HORIZONTAL DISPLAY	B INTENS BY 'A'
DELAY-TIME MULTIPLIER	About 0.20
B TRIGGERING MODE	AUTO

Monitor the signal available at the +GATE connector on another oscilloscope and establish the desired pulse repetition rate by setting the B TIME/CM or DELAY TIME switch and VARIABLE B control. Establish the desired duty factor by setting the A TIME/CM switch.

The maximum pulse repetition frequency that can be obtained in this manner is 60-90 kc. Maximum duty factor is about 0.9, decreasing to about 0.15 with faster sweep rates.

TRIGGERED DELAYED SWEEP

Complex signals contain a number of individual events at different amplitudes. Since the trigger circuits in the Type 547 respond to signal amplitude, a stable display will normally be obtained only when the sweep is triggered by the event having the greatest amplitude.

The following instructions demonstrate that Time Base A can be triggered by any event with a series of events, regardless of relative amplitude.

Set the controls and switches on the instrument as listed in Table 2-1.

Connect the AMPLITUDE CALIBRATOR signal to the vertical input. You should obtain a square-wave display.

Turn the DELAY-TIME MULTIPLIER dial about 2 turns in either direction. Notice that the brightened segment in the display moves smoothly across the crt.

Set the DELAY-TIME MULTIPLIER dial so the brightened segment begins about in the middle of a pulse top. Now, set the A MODE switch to TRIG and the A SOURCE switch to NORM. Notice that the brightened segment in the display has shifted to the next pulse on the right. (If the brightened segment is not present, or is unstable, readjust the A TRIGGERING LEVEL control.) Turn the DELAY-TIME MULTIPLIER dial several full turns. The brightened segment in the display should jump from one pulse to the next. Set the HORIZONTAL DISPLAY switch to A DLY'D and notice that the display now begins on the rising portion of the pulse. With the present display, turning the DELAY-TIME MULTIPLIER dial should not change the display since all of the AMPLITUDE CALIBRATOR pulses are the same shape. However, if the input signal consisted of a repeating series of several dissimilar pulses, turning the dial would provide a triggered display of each pulse in the series (provided the A TRIGGERING LEVEL control is set for triggering on the smallest pulse).

The display is produced in the following manner:

Time Base A produces one sweep during each B sweep. The Time Base A sweep will begin some time after the start of B sweep. This time is the total of the B TIME/CM or DELAY TIME switch setting multiplied by the DELAY-TIME MULTIPLIER dial setting, plus the time between the end of this delay interval and the next event in the signal which can trigger Time Base B.

With the A TRIGGERING MODE switch in the TRIG position, the Time Base A sweep will occur only if A is armed and triggered before the B sweep ends. If Time Base A is not triggered, the scope waits.

Polarized Light Filter

The polarized light filter provided with the Type 547 minimizes undesirable reflections when viewing the display under high ambient light conditions. The filter may be left on when taking waveform photographs unless a high writing rate is required.

If the light filter is removed, the CRT protector plate should be installed to prevent scratches to the CRT face plate.

EXTERNAL HORIZONTAL DEFLECTION

For special applications, horizontal deflection can be produced with an externally derived signal. Thus, the oscilloscope system can be used to plot one function against another (e.g. Lissajous figures). However, the system is not intended for precise phase-angle measurements.

To use an external signal for horizontal deflection, connect the signal to the HORIZ INPUT connector. Set the HORIZONTAL DISPLAY switch to EXT. The signal is dc coupled to the deflection amplifier. The MAG switch is inoperative when the HORIZONTAL DISPLAY switch is set to either external horizontal position.

COOLING

A fan maintains safe operating temperature in the Type 547 by circulating filtered air over the power supply rectifiers, regulators, and other circuit components. When in operation, the instrument must be placed so that the air intake at the back and the vents in the side panels are clear of any obstruction that might impede the flow of air. Allow at least 3 inches clearance at the rear of the instrument and 2 inches at each side. The side panels should be in place (except during maintenance adjustments) for proper air circulation inside the instrument.

The Type 547 should never be operated without the fan running, since temperatures within the instrument will rise to a dangerous level in a few minutes. In this event, the thermal cutout switch disconnects the power and keeps it disconnected until the temperature drops to a safe level.

POWER REQUIREMENTS

General. The Type 547/RM547 will regulate with input line voltages which are within 10% of designed center voltage range. Two possible methods of connecting the oscilloscope for use with the appropriate power supplies exist, and

the method to be used is determined by the serial number of the instrument as follows:

SN 7980 and Above

The Type 547 can be operated from either a 115-volt or a 230-volt nominal line-voltage source. The Line Voltage Selector assembly on the rear panel converts the instrument from one operating range to the other. In addition, this assembly changes taps on the primary winding of the power transformer to allow selection of one of three regulating ranges. The assembly also includes the two line fuses. When the instrument is converted from 115-volt to 230-volt nominal operation, or vice versa, the assembly installs the proper fuse to provide instrument protection.

To convert from one nominal line voltage to the other and/or change regulating ranges, use the following procedure. (See Fig. 2-5)

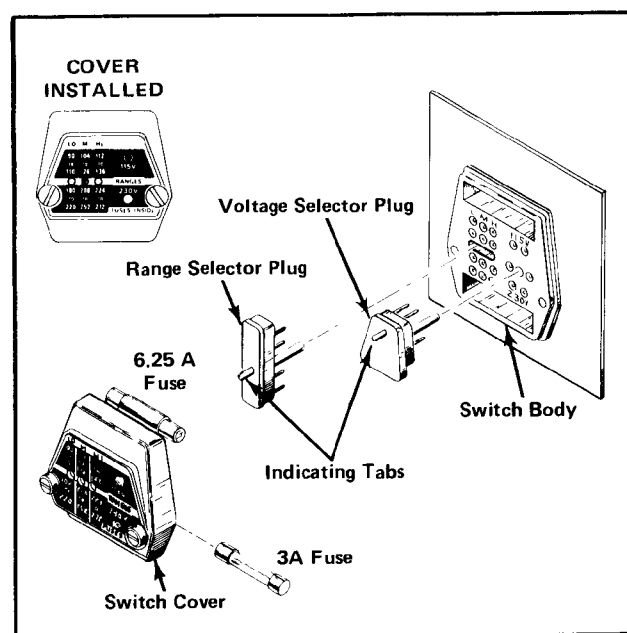

Fig. 2-5. Voltage Selector assembly. Oscilloscope serial number 7980 and above.

1. Disconnect the instrument from the power source.
2. Loosen the two captive screws that hold the cover in the voltage selector switch base; then remove the cover by pulling it straight away from the base.
3. To change nominal line voltage selection, pull out the Voltage Selector plug, (see Fig. 2-5) rotate it 180° and plug it back in.

Operating Instructions—Type 547/RM547

4. To change regulating ranges, pull out the Range Selector plug (see Fig. 2-5), slide it left or right to the desired position and plug it back in. Select a range which centers about the average line voltage to which the instrument is to be connected (see Table 2-2).

5. Re-install the cover and tighten the two captive screws, making sure that the indicating tabs are protruding through the correct holes in the cover for the desired line voltage and regulating range.

6. Re-connect the instrument to the power source.

CAUTION

Operation of this instrument with the Voltage Selector or Range Selector switch in the wrong position for the applied line voltage may damage the instrument or cause improper operation.

TABLE 2-2

Regulating Ranges SN 7980 and Above

Range Selector Switch Position	Voltage Selector	
	115-Volts Nominal	230-Volts Nominal
LO (switch bar in left holes)	90 to 110 volts	180 to 220 volt
M (switch bar in middle holes)	104 to 126 volts	208 to 252 volt
HI (switch bar in right holes)	112 to 136 volts	224 to 272 volt

SN 7979 and Below

Unless otherwise indicated, the Type 547 is shipped with the power transformer and fan wired for 115-volt AC input. Fig. 2-6 and a connection diagram on the side of the transformer show alternate connections for other input voltages to the power transformer. When the transformer is changed from 108-122 volts to 216-244 volts connection, the fan wiring must also be changed. Fig. 2-7 shows the fan connections for each voltage range.

Transformer and Fan Connections SN 7979 and Below

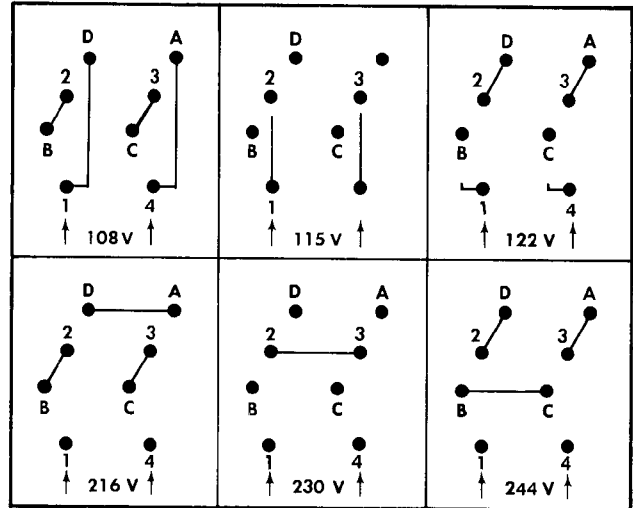

Fig. 2-6. Transformer connections for 108 to 244 volt, 50 to 60 cps. SN 7979 and below.

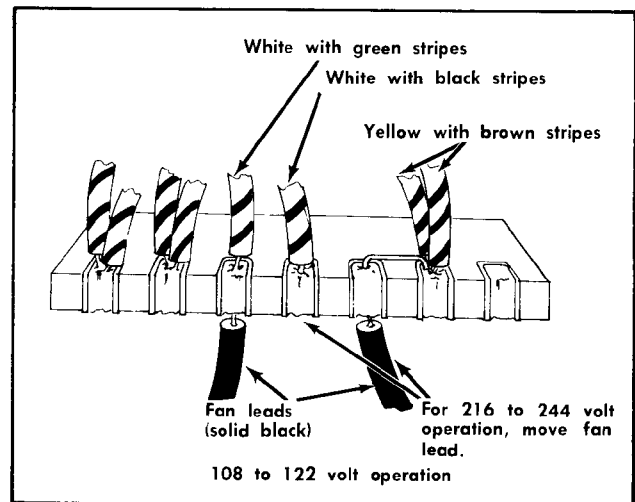

Fig. 2-7. Fan connections for 108 to 244 volt, 50 to 60 cps. SN 7979 and below.

SECTION 3

CIRCUIT DESCRIPTION

Introduction

This section contains the theory of operation of the various circuits in the Type 547. A simplified block diagram analysis is given first to explain the operation of each circuit in general terms, then the operation of each circuit is covered in detail.

BLOCK DIAGRAM ANALYSIS

In the following analysis, it is assumed that the oscilloscope is equipped with a dual-channel vertical plug-in preamplifier, and that the horizontal display switch is set in the ALT position between the A DLY'D BY B and the B INTENS BY 'A' positions. Fig. 3-1 is a simplified block diagram showing the Type 547 operating in this mode. Detailed block diagrams showing circuit configuration for this and other modes of operation are contained in Section 6. The functions of the various blocks in Fig. 3-1 are explained in the following paragraphs.

Low-Voltage Power Supply. The low-voltage power supply produces all operating voltages for the oscilloscope with the exception of parts of the crt circuit. The low-voltage supply provides regulated -150 , $+100$, $+225$, and $+350$ volts. It also provides heater voltages and an unregulated $+325$ -volt output.

Vertical Plug-In Preamplifier. Any Tektronix letter-Series or 1-Series vertical plug-in preamplifier can be used with the Type 547. For a circuit description of the plug-in unit refer to the plug-in unit instruction manual.

Vertical Input Amplifier. The vertical input amplifier is a balanced, hybrid amplifier that amplifies the output of the plug-in vertical preamplifier and applies the amplified vertical signal to the trigger-pickoff circuit and the vertical output amplifier.

Delay Line. The push-pull output of the vertical input amplifier is applied through the balanced delay line to the vertical output amplifier. The delay line is a specially braided 186-ohm line which delays the application of the vertical signal to the vertical output amplifier for 170 nsec. This provides time for unblanking crt and starting the horizontal sweep before the vertical signal reaches the deflection plates. The delay allows the leading edge of a single fast-rising pulse to be displayed. The delay line requires no adjustment because of the precision construction.

Vertical Output Amplifier. The vertical output amplifier is a push-pull three-stage, transistor amplifier that takes the output of the delay line and amplifies it to a level sufficient to drive the vertical deflection plates of the crt.

Trigger-Pickoff Circuit. The trigger-pickoff circuit applies a sample of the input waveform to the trigger circuits of both time bases. The trigger is picked off at the output of the vertical input amplifier.

Main Time Base (B) Generator. The main time base (B) generator provides accurate ramp voltages for the horizontal deflection system, unblanking for the crt, sync pulse for the sweep switching circuit, and a $+B$ gate to a front-panel connector. The main time base (B) generator may be triggered by signals derived from either internal or external sources.

Delay-Pickoff Circuit. The delay-pickoff circuit compares the ramp-voltage output of the main time base (B) generator with a variable reference voltage, and assuming identical characteristics in the two halves of the comparator, generates a trigger pulse when the two voltages are equal. The trigger output of the delay-pickoff circuit may be used to arm or trigger Time Base A, and is also available at a front-panel connector.

Alternate-Sweep Switching Circuit. When the HORIZONTAL DISPLAY switch is in either of the alternate modes, the alternate-sweep switching circuit performs the following functions:

1. Gates the ramp signals from the time-base generators into the horizontal amplifier and thereby decides which of the two time-base generators is to be displayed.
2. Provides the vertical plug-in preamplifier with dual-trace slaving pulses.
3. Applies trace-separation voltage to the vertical amplifier during the A sweep.
4. Disables the B sweep unblanking circuit during presentation of the delayed A sweep.

In the A ALT B position of the HORIZONTAL DISPLAY switch, the alternate-sweep switching circuit provides sweep-generator lockout voltages to the horizontal display switch.

Horizontal Amplifier. The input to the horizontal amplifier is selected from the outputs of the main time base (B) generator, time base A generator, or the external horizontal input amplifier. The selected input is split in phase and amplified to provide push-pull drive to the horizontal deflection plates of the crt.

External Horizontal Amplifier. The external horizontal input amplifier provides the necessary gain to drive the horizontal amplifier from external signals. An input attenuator and a gain control provide horizontal deflection factors from 0.1 to about 10 volts/cm.

Crt Power Supply. The crt power supply provides the high voltages for operating the crt. The power supply is of the rf type, using a 50-kc Hartley oscillator. Secondary windings on the oscillator transformer supply voltages to the high-voltage rectifiers.

Cathode Ray Tube (Crt). The cathode-ray tube used in the Type 547 is a flat-faced, internal graticule, 5-inch tube

Circuit Description—Type 547/RM547

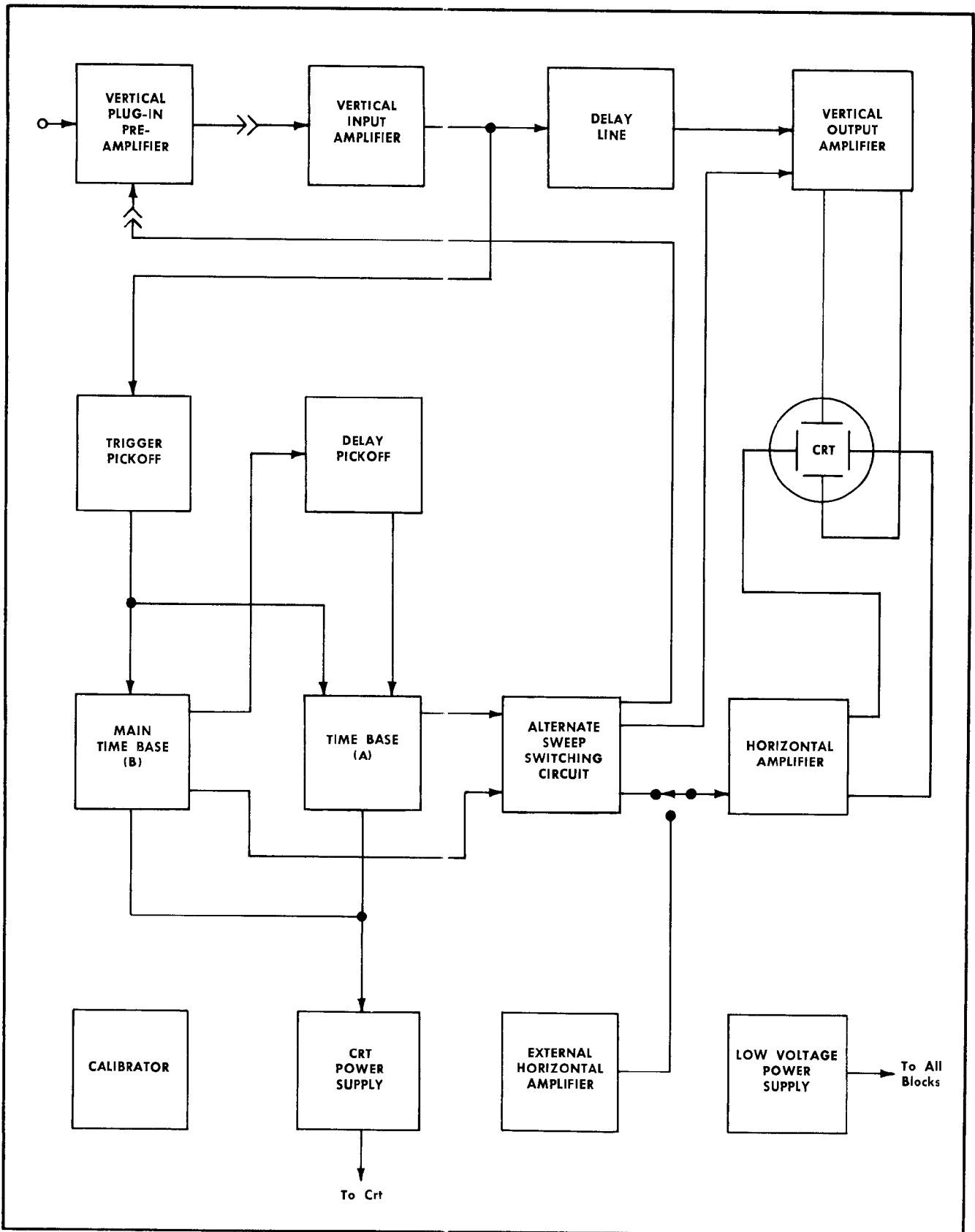

Fig. 3-1. Type 547 simplified block diagram.

with 6 cm of usable vertical scan area. The tube is designed for low input capacitance to the vertical deflection plates and minimum x-axis center-to-edge defocusing.

Calibrator. The calibrator in the Type 547 is a multivibrator and cathode follower that provides a square-wave output with a maximum amplitude of 100 volts at a nominal 1 kc. A step attenuator permits switching the output amplitude from the front panel. In the 0.2-mvolt to 200-mvolt range, the output impedance is 50 Ω .

Time Base A Generator. The time base A generator closely resembles the main time base (B) generator. The description of functions and the circuit analysis given for the time base (B) generator in most instances apply also to the time base A generator.

CIRCUIT ANALYSIS

The following circuit analysis of the Type 547 describes the operation of the various circuits in detail. While reading through the description of a particular circuit, refer to the circuit diagram being discussed (see Section 6).

Low-Voltage Power Supply

The low-voltage power supply in the Type 547 (see Power Supply schematic) actually consists of four interrelated supplies that operate together as a system. This system delivers filtered and regulated voltages of -150 , $+100$, $+225$, and $+350$ volts as well as an unregulated dc voltage of $+325$ volts. A common power transformer, T601, supplies the input power to each of the supplies, as well as heater power to thermal time-delay relay K600 and the tubes in the oscilloscope. Unless otherwise specified, the Type 547 is shipped with T601 wired for 115-volt ac input. A connection diagram on the side of the transformer shows alternate connections for other input voltages for SN 7979 and below. For SN 7980 and above, a Voltage Selector assembly is provided (see Operating Instructions section of this manual).

The 115-volt ac input power is applied to T601 through POWER ON switch SW601. Overload protection is provided by fuse F601. Thermal cutout TK601 in the primary circuit of T601 is a protective device that opens the transformer primary circuit if the temperature inside the oscilloscope rises above a safe value. TK601 resets automatically when temperatures return to normal; and to shorten the cooling time, the fan continues to run while TK601 is open (except when T601 is connected for 210-250-volt operation). Thermal time-delay relay K600 provides a filament warmup time of approximately 30 seconds before the dc power supplies are activated. The heater of K600 is rated at 6 volts and is connected to 6.3 volts on the T601 secondary winding. During heater warmup time, contacts 4 and 9 of relay K600 remain open. At the end of heater warmup time, contacts 4 and 9 close and apply power to magnetic relay K601. Contacts K601-1 of relay K601 remove the heater power from K600, but before K600 can open, contacts K601-1 lock the holding circuit to the coil of K601. K601 now remains energized until the power to the oscilloscope is switched off or otherwise interrupted. When K601 is energized, contacts K601-2, K601-3, K601-4, K601-5, and K601-6 are also closed and thus activate their respective dc supplies.

-150 -Volt Supply. The -150 -volt supply in the Type 547 is the reference voltage source for the other supplies and must be very stable. The -150 -volt supply includes a high-gain electronic voltage regulator designed to give good regulation under extreme operating conditions. This regulator circuit contains a series regulator, a glow-discharge tube reference source, an error detector, and an amplifier.

In operation, the input power to the -150 -volt supply is supplied by one secondary winding of T601. The ac output of the secondary winding is rectified by silicon-diode rectifier bridge D642 and filtered by capacitor C642A. In series with the positive side of the supply and ground are series regulator tubes V637 and V647, paralleled by shunting resistors R646 and R647. The output of the -150 -volt supply is taken from the negative side.

Error sensing in the voltage-regulator circuit is accomplished by comparator tube V624. Current flow through V624 is established by the setting of the tap on R616 in the voltage divider R615, R616, and R617. The voltage on the grid of V624A is held at approximately $+85$ volts by reference tube V609. Assuming that the output voltage of the -150 -volt supply increases due to increased line voltage or some other cause, the voltage increase appears on the cathodes of V624 and through the tap on R616, on the grid of V624B. Due to the voltage divider, only a part of the voltage increase appears between the grid and cathode of V624B, but the full change appears on the grid and cathode of V624A. The increase is in the negative direction, therefore, V624A increases its conduction to maintain the proper bias between grid and cathode, and this holds both cathodes more or less fixed while the grid of V624B is pulled negative by the increasing negative voltage across the voltage divider. The increasing negative voltage on the grid of V624B causes a decrease in current; thus the plate voltage goes positive.

The positive change in plate voltage is amplified and inverted to a negative change by amplifier tube V634. The amplified error signal from V634 is applied to the grids of series regulator tubes V637 and V647. The negative-going error signal on the grids of V637 and V647 decreases the current through the tubes, effectively increasing their resistance and the voltage drop across them. The voltage necessary to provide the increased drop across the series regulator tubes and shunt resistor can only be obtained by subtracting it from the negative side of the supply, so the undesired increase in negative voltage is absorbed in the series regulators and shunt resistors. If the output of the -150 -volt supply had decreased instead of increased, then the error voltage applied to the grids of the series regulators would have been positive-going. The positive-going error voltage on the grids of the series regulators would lower the resistance of the series regulator tubes, and the voltage drop across them would decrease, leaving more voltage for the negative side of the supply. Since the output voltage of the -150 -volt supply depends upon the relationship of the voltage on the tap of R616 and the reference voltage from V609, accurate adjustment of the output voltage is provided by making R616 variable.

Filter capacitor C642A does not remove all the ripple from the output of the bridge rectifier, and the series regulator circuit functions also to reduce this output ripple voltage. Any ripple between the -150 -volt output point and ground reaches the grid (pin 2) of V624A via capacitor C610. This

Circuit Description—Type 547/RM547

input ripple voltage is amplified by V624 acting as a cathode-coupled amplifier. The ripple output voltage at the plate (pin 6) of V624B has the same polarity as the ripple voltage at the -150 -volt output. C628 couples this ripple output voltage to the grid of V634. The ripple voltage is further amplified by V634 and applied to the grids of the series regulator tubes with a polarity that opposes the original ripple voltage. Ripple in the positive side of the -150 -volt supply is coupled into a degenerative feedback loop through R637 to the screen of V634.

Some of the components in the -150 -volt supply are not necessary in normal operation but are included to insure proper operation of the circuit under adverse conditions. C636 provides for proper operation of the circuit when extremely low temperatures reduce the capacitance of the electrolytic filter capacitors. R640 and R641 protect against large surge currents, and C642B suppresses sudden load changes that fall outside the bandwidth of the regulator circuit.

+100-Volt Supply. The input to the $+100$ -volt supply is the output of secondary winding 19-20 of transformer T601 and silicon-diode bridge D672. In addition to its other loads, the $+100$ -volt supply is required to supply current to a series string of filaments at all times. When the Type 547 is first turned on, relay K601 contacts are open and all the regulated supplies are inoperative. During this time, the series-string filaments are supplied by the unregulated side of the $+100$ -volt supply through relay contacts K601-4. By the time thermal relay K600 activates K601, the series-string filaments have reached operating temperature. When K601 is activated by K600, relay contacts K601-4 shift the series-string filaments to the regulated output of the $+100$ -volt supply.

The reference voltage source is the regulated output of the -150 -volt supply. V664A is the error amplifier, V664B compensates for V664A grid-cathode contact bias changes caused by changing line voltage, and V677 is the series regulator tube. The error-feedback circuit is through R650 and R651, the junction of which is connected to the grid of V664A. The top end of R650 is connected to the regulated $+100$ -volt output, and the lower end of R651 is connected to the output of the regulated -150 -volt supply to obtain reference voltage. With normal line voltages and loads, the voltage at the junction of R650 and R651 is about -1.7 volts with reference to ground; this is the operating bias of V664A.

If the load current, output voltage, or the input voltage changes (including changes due to ripple), the output of the regulated $+100$ -volt supply starts to change also, but any change appears across R650 and R651 and is applied to the grid of V664A as a change in operating bias. Assuming that the output of the regulated $+100$ -volt supply tries to decrease, the reduced voltage at the top end of R650 permits the voltage at the junction of R650 and R651 to go more negative than the normal -1.7 -volt level at that point. The increase in negative bias on the grid of V664A reduces the flow of plate current through V664A, the voltage drop across plate load resistor R663 decreases, and the plate voltage of V664 and the grid bias of V677 go more positive. As the grid of V667 goes more positive, the resistance that V677 offers to the flow of current is decreased and the output voltage rises, compensating for the drop in output voltage which initiated regulating action. Of course, the

regulator circuit can never completely compensate for a change in output voltage, for there must be an error input for the circuit to operate, but any error in output is reduced by a factor equal to the loop gain of the regulator circuit.

The screen grid of V664A is used as a signal grid for injecting a sample of any ripple or transient voltage present in the unregulated side of the $+100$ -volt supply into the regulator circuit. The regulator circuit thereby becomes a dynamic filter for ripple reduction. The ripple signal is applied to the screen of V664A, amplified and inverted in phase by V664A, then applied to the grid of V677. By the time the amplified and inverted ripple gets to the grid of V677, it is of proper amplitude and phase to cancel out the ripple appearing at the plate of V677.

To keep the proper load on the $+100$ -volt supply when the vertical plug-in preamplifier is removed, a plug-in sensing switch is built into the main frame of the Type 547 at the top rear of the plug-in compartment. When the plug-in unit is removed, the sensing switch connects a resistive load in place of the series-filament string. When it is desired to operate the plug-in unit outside the Type 547 by means of a test harness, the sensing switch must be manually operated. To manually operate the switch, pull the plastic plunger outward to the stop position.

Unregulated +325-Volt Supply. The unregulated $+325$ -volt supply voltage source differs somewhat from the voltage sources for the -150 - and $+100$ -volt supplies. A center-tapped secondary (13-14-15) on T601 and silicon diodes D702 and D732 form a center-tapped bridge rectifier circuit with the negative side connected to the positive unregulated side of the voltage source for the $+100$ -volt supply. The unregulated $+325$ -volt output is taken from the transformer center-tap (14) connection.

The unregulated output of the voltage source for the $+100$ -volt supply is approximately $+180$ volts. The unregulated output of the center-tapped bridge circuit is approximately $+290$ volts; this, added to the unregulated $+180$ volts provides the $+470$ volts. However, for the unregulated $+325$ -volt output, the connection is made at the center tap ($+145$ volts) of the bridge (the midpoint of the $+290$ volts). Adding the $+180$ and $+145$ volts provides the desired output of $+325$ volts.

+225-Volt Supply. The voltage source for the regulated $+225$ -volt supply is the unregulated $+325$ -volt supply described in the preceding paragraphs. The regulator circuit is similar to the regulator circuit found in the -150 -volt supply; the main difference being that instead of using a glow discharge tube as a reference voltage source, the reference voltage is from the -150 -volt supply. The error signal is picked off the junction of precision resistors R680 and R681. The upper end of R680 is connected to the $+225$ -volt output, and the lower end of R681 is connected to the regulated -150 -volt supply. The voltage at the junction between R680 and R681 is approximately -0.9 volt which is applied through R682 and R683 to the grid of V684B. The cathodes of V684 are longtailed to the -150 -volt supply through 82 k resistor R685. The grid of V684A is grounded. The error signal is fed from the grid of V684B through the common-cathode circuit to the A side of the tube. Notice that this comparator is somewhat different from the comparator used in the -150 -volt supply; the output is taken from the A

side. The error signal is amplified by V684 and fed, unchanged and in phase, to the voltage divider in the grid of V694. V694 also amplifies and inverts the error signal and applies it out of phase with any change in the +225-volt output, to the grid of series regulator tube V707.

Here again, the screen of the error amplifier tube is acting as an injection grid for ripple reduction. A sample of the unregulated supply ripple is applied to the screen of V694. V694 amplifies the ripple, inverts it in phase, and applies it to the grid of series regulator tube V707. The result is that the same ripple appears simultaneously on the grid and plate of V707, but 180° out of phase; thus the ripple cancels out.

+350-Volt Supply. The input to the +350-volt supply is the full voltage output of the center-tapped bridge (see description of unregulated +325-volt supply) added to the unregulated side of the +100-volt supply. The operation of the regulator circuit is very similar to the operation of the +100-volt regulator except for different component values and no grid-cathode contact-bias compensating diode.

Crt Circuit

The crt circuit (see Crt schematic) includes the crt, the high-voltage power supply, and the controls necessary to focus and orient the display. The crt (Tektronix Type T5470-31-2) is an aluminized, 5-inch, flat-faced, glass crt with a helical post-accelerator and electrostatic focus and deflection. The crt circuit provides connections for externally modulating the crt cathode. The high-voltage power supply is composed of a dc-to-50-kc power converter, a voltage-regulator circuit, and three high-voltage outputs. Front-panel controls in the crt circuit adjust the trace rotation (screwdriver adjustment), intensity, focus, and astigmatism. Internal controls adjust the geometry and high-voltage output level.

High-Voltage Power Supply. The high-voltage power supply is a dc-to-ac converter operating at approximately 50 kc with the transformer providing three high-voltage outputs. The use of a 50-kc input to the high-voltage transformer permits the size of the transformer and filter components to be kept small. A modified Hartley oscillator converts dc from the +325-volt unregulated supply to the 50-kc input required by high-voltage transformer T801. C808 and the primary of T801 form the oscillator resonant tank circuit. No provisions are made for precise tuning of the oscillator tank since the exact frequency of oscillation is not important.

Voltage Regulation. Voltage regulation of the high-voltage outputs is accomplished by regulating the amplitude of oscillations in the Hartley oscillator. The -1850-volt output is referenced to the +350-volt regulated supply through a voltage divider composed of R841, R842, R843, R845, R846, R847, R853, and variable resistors R840 and R846. Through a tap on the voltage divider, the regulator circuit samples the -1850-volt output of the supply, amplifies any errors and uses the amplified error voltage to adjust the screen voltage of Hartley oscillator V800. If the -1850-volt output changes, the change is detected at the grid of V814B. The error signal is amplified by V814B and V814A. The error signal at the plate of V814A is direct coupled to the screen of V800 by making the plate-load resistor of V814A serve as

the screen-dropping resistor for V800. Any change in the -1850-volt output thus changes the screen voltage of V800 and the amplitude of the 50-kc oscillations. R840 provides a means of controlling the high-voltage output through controlling oscillation amplitude.

Crt Grid Supply. The approximately -1950-volt output of the high-voltage power supply is the rectified output of one of the two high-voltage secondaries on T801. To provide dc-coupled unblanking signals to the crt grid, the crt grid supply is floating (the dc voltage levels on the components shift in accordance with the unblanking signals). The positive side of the crt grid supply is returned to the -150-volt supply through the unblanking cathode-follower load resistor of the selected sweep generator and through R831 and R832. The negative side of the crt grid supply is applied through the INTENSITY control to the crt grid.

At the fastest sweep rates, the stray capacitance of the floating crt grid circuit makes it difficult for the crt grid to rise fast enough to unblank the crt in the required time. An isolation network consisting of R827, R828, C828, C829, and C830 isolates the capacitive loading. By this arrangement, the fast leading edge of the unblanking pulse is coupled through C830 and C828 to the grid of the crt. For short-duration unblanking pulses, such as those that occur at the fastest sweep rates, the dc levels on the rectifier and secondary winding are not appreciably affected. Longer unblanking pulses, such as those that occur at the slower sweep rates, charge the stray capacitance in the -1950-volts output through R827. This pulls up the floating crt grid circuit and holds the crt grid at the unblanked potential for the duration of the unblanking pulse.

+8150 and -1850-Volt Outputs. Both the +8150 and the -1850-volt outputs are derived from the same secondary winding on T801. The full secondary voltage of approximately 2900 volts is applied to a voltage tripler consisting of rectifiers V832, V842, and V852 and associated capacitors. A tap on the secondary provides the input for half-wave rectifier V862 in the -1850-volt output. Both outputs are referenced to the regulated +350-volt supply through a voltage divider network. The +8150-volt output is connected to the crt post-deflection-accelerator anode and the -1850-volt output is connected to the crt cathode, providing a total accelerating voltage of 10,000 volts.

Crt Circuit Controls and Connectors. Optimum size and shape of the fluorescent spot on the crt is obtained by adjusting the front-panel FOCUS and ASTIGMATISM controls. FOCUS control R846 provides the correct voltage for the second anode (focus ring) in the crt. Proper voltage for the third anode is obtained by adjusting ASTIGMATISM control R864. In order to obtain optimum spot size and shape, both the FOCUS and ASTIGMATISM controls are adjusted to provide the proper electronic lens configuration in the region of the second and third anodes of the crt. Spot intensity is adjusted by means of front-panel INTENSITY control R826. Varying the INTENSITY control changes the voltage on the crt grid, which in turn varies the density of the electron stream. Internal GEOMETRY control R861 adjusts the isolation shield voltage in the crt, and is adjusted to minimize "bowing" or "tilting" of the display. Front-panel TRACE ROTATION control R778 permits minor adjustments in trace orientation. By adjusting the TRACE ROTATION control,

Circuit Description—Type 547/RM547

the trace can be made parallel with the horizontal lines on the graticule, eliminating the need to physically turn the crt to correct for minor deviations of the trace from the horizontal.

An input binding post on the rear panel of the Type 547 provides an input for externally modulating the crt cathode. The input binding post is normally grounded by a link. If it is desired to intensity modulate the display from an external source, the link is opened, and the modulating signal is coupled to the crt cathode through C858.

When the Type 547 is used with a multichannel vertical plug-in preamplifier that provides dual-trace chopped blanking pulses, the blanking pulses are applied to rear-panel CRT CATHODE SELECTOR switch SW858. With the vertical plug-in preamplifier operating in the chopped mode and SW858 set to the CHOPPED BLANKING position, a positive pulse of approximately 20-volts amplitude is applied through C858 to the cathode of the crt. At normal intensity levels, this pulse is sufficient to cut off the crt during the time the amplifier channels in the vertical plug-in preamplifiers are being switched.

Vertical Amplifier System

The vertical amplifier system in the Type 547 consists of an appropriate vertical plug-in preamplifier, a push-pull cathode-follower input stage, a push-pull transistorized delay-line driver, a delay line, and a push-pull transistorized output amplifier. In addition, the trigger-pickoff circuit functions as a part of the vertical amplifier by providing reverse termination for the delay line.

Vertical Input Amplifier. The push-pull output of the vertical plug-in preamplifier, with a fixed dc level of approximately +67.5 volts, is applied to the input of the vertical amplifier through terminals 1 and 3 of the plug-in connector.

Transient-response compensation switch SW1000, capacitor C1000, and resistor R1000 at the input of the vertical amplifier compensate for the difference in transient response that exists between different models of vertical plug-in preamplifiers. SW1000 is actuated by a mechanical sensing device when the plug-in unit is inserted into the oscilloscope, and requires no attention on the part of the operator.

R1001 and R1011, in series with the grids of the push-pull cathode-follower stage, are parasitic suppressors. Input cathode followers V1003A and V1003B are the two halves of a 12AT7 twin triode. The cathodes of the cathode followers are returned to ground through vertical dc balance control R1004, which is adjusted to equalize the dc voltage (about +68.5 volts) on the bases of delay-line driver transistors Q1014 and Q1024. The heaters of V1003 are operated as part of the series string which receives power from the +100-volt dc supply. The use of dc on the heater prevents changes in line voltage from affecting the gain of the vertical amplifier.

The balanced delay-line driver stage is a push-pull amplifier with an adjustable vertical gain control (R1017) connected in the emitter circuit of the two transistors. Gain is adjusted by controlling the amount of degeneration in the emitter circuit. Zener diode D1018 sets the operating points of the termination transistors on both ends of the delay line.

The RC networks in the collectors of Q1014, Q1024, Q1144, Q1154, and in the emitter leads of Q1034 and Q1044 set the individual transistor operating points to achieve thermal balance. The 5-turn center-tapped coils at the input of the delay line and the collector-base capacitance of the delay-line driver transistors form a T-section matching network. C1029 provides a means of varying the impedance of the T section.

Vertical Output Amplifier. The vertical output amplifier must properly terminate the delay line and provide broad-band amplification of the vertical signals. Proper termination of the delay line is obtained by connecting forward-termination transistors in a common-base configuration. The common-base configuration also operates well in broad-band amplifier applications. To help meet the broad-band requirement, the collector load circuit of the termination transistors contains RC low-frequency compensation networks, and in addition, LR network in the collectors of transistors Q1034 and Q1044 compensate for losses due to skin effect within the delay line.

Following the forward-termination amplifier is a wide-band amplifier stage consisting of Q1074 and Q1084 and associated elements. High-frequency compensation in this stage is provided by shunt peaking coils L1072 in the collector circuits. The high-frequency response is varied by adjusting C1076, which provides variable high-frequency degeneration in the emitter circuit of Q1074 and Q1084.

The output stage of the vertical amplifier is a transistorized equivalent of a push-pull cascode amplifier. This circuit configuration is used to match the low impedance of the transistorized vertical-amplifier system to the higher impedance required at the crt vertical deflection plates. High-frequency compensation is provided by rc networks between the collector of the driving transistor and the emitter of the driven transistor on each side. C1105 and C1106 provide a means of varying the high-frequency response of the output stage. The outputs from Q1114 and Q1134 are connected to the deflection plate of the crt via series-peaking coils L1115 and L1135.

Trigger-Pickoff Circuit. The trigger-pickoff circuit provides reverse termination for the delay line as mentioned in the preceding paragraphs. The input stage of the trigger-pickoff circuit, which provides the delay-line reverse termination, is a common-base circuit. The output stage of the trigger-pickoff circuit is a push-pull emitter-follower amplifier that not only provides trigger signals to the two time bases, but supplies the VERT SIG OUT jack with a vertical signal and drives position-indicator amplifier V1184.

Main Time Base (B)

The main time base (B) consists of the B sweep trigger and the B sweep generator circuits. The B sweep trigger circuit is a wide-band hybrid amplifier driving a tunnel diode. The B sweep trigger circuit includes controls for selecting the type, source, and level of the trigger to be used, and circuit elements for regenerating the selected trigger into a pulse suitable for triggering the B sweep generator. The B sweep generator circuit is basically a Miller-runup circuit. The B sweep generator provides ramp voltages for the horizontal deflection system, alternate-trace sync pulses, unblanking pulses, and +B gate pulses.

Trigger Generator

The input to the B sweep trigger circuit (see B Sweep Trigger Generator schematic) is selected by SOURCE switch SW1 from the trigger-pickoff circuit in the vertical amplifier, the trigger output of the vertical plug-in preamplifier, the power transformer for line triggering, or from the front-panel TRIGGER INPUT connector. COUPLING switch SW5 permits further selection of the type of triggering signal; either ac, ac with low frequencies rejected, or dc. Once the type and source of triggering signal has been selected, the slope on which triggering is desired is selected by SLOPE switch SW10. The level of the triggering signal required by the B sweep trigger circuit is selected by adjusting TRIGGERING LEVEL control R15. After this triggering signal has been selected by the foregoing controls and switches, it is applied to trigger input amplifier V24.

Circuit Description SN 6740-UP. V24A and V24B form a switching comparator. The voltage level at which the comparator switches is set by the B TRIGGERING LEVEL control R15. V24 drives Q34 and Q44, which form a current type switching comparator. Q34 and Q44 drive tunnel diode D45 which in turn drives sweep gating tunnel diode D85.

If no triggering signal is applied to V24 the stage consisting of V24A and V24B is unbalanced. One section (which one depends upon the setting of the B SLOPE and B TRIGGERING LEVEL controls) is conducting more current than the other. The voltages at the plates of V24A and V24B should therefore be different. However, diodes D21 and D22 clamp the two plate voltages to within 0.3 volt of each other, with the plate of the section which is conducting the most current being the most negative.

The second stage, made up of Q34 and Q44, is also unbalanced. The transistor whose base is the most negative conducts most of the current supplied by R36. This

current is not sufficient to cause the conducting transistor to saturate. The conducting transistor merely acts as a constant current source.

Tunnel diode D45 is biased to its low voltage state by current through R32, R33, R45, and R42. If the comparator stages are unbalanced in such a manner as to cause Q34 to conduct, an additional current flows through D45. This additional current biases D45 to its high voltage state (see Fig. 3-2 for tunnel diode characteristic curve).

When the current through D45 reaches a total of 10 mA the voltage across D45 will suddenly increase to approximately 0.5 volts. This sudden voltage change is coupled to the sweep gating tunnel diode D85 by C56, D59, and C57. C56 differentiates the triggering signal which provides a fast rising pulse for D85. L56 and the low impedance of conducting diode D57 decrease the fall time of the triggering pulse. D59 ensures that D85 is only triggered when D45 turns on, and not when D45 turns off.

Circuit Operation SN 101-6739. In operation, V24A and V24B form a push-pull amplifier which drives a push-pull input, single-ended output amplifier consisting of Q34 and Q44. Tunnel diode D45 is biased at its low-voltage state (see Fig. 3-2 for trigger tunnel-diode curve) by current flow through the voltage divider consisting of R44, R45, R47, and R48. When the desired slope of the triggering signal selected arrives at the grids of V24, V24B and Q44 are biased into conduction. The conduction of Q44 increases the current flow through D45, and D45 switches to its high-voltage state. The sudden voltage change across D45 as it switches to its high-voltage state produces a uniform fast-rising trigger pulse which is used to trigger the main time base (B) sweep generator.

Sweep Generator

For purposes of explanation, assume that the HORIZONTAL DISPLAY switch (see B Sweep-Generator schematic) is in the B position, the SINGLE SWEEP switch is in the NORMAL position, the TRIGGERING MODE switch is in the TRIG position and that no trigger is being applied. Under these conditions, V145A in the holdoff multivibrator is conducting and V145B is cut off. The paths for the current in V145A are from the -150 -volt supply through R164 and D163 in parallel with R163. When V145A is conducting and no trigger is being received from the trigger generator, D85 is in its low-voltage state since the dc current supplied from the $+100$ -volt supply through R82 and R81 is less than the peak current of D85. Under these conditions, Q84 is cut off. For SN 12480 and above, the collector voltage of Q84 is positive, thereby forward biasing Q86, D86, Q89 and Q103. (For units with serial numbers below SN 12480, the collector voltage of Q84 is positive, thereby forward biasing D86, Q89 and Q103.) Miller tube V91 is conducting. The circuit is now ready to be triggered.

Assuming that a trigger pulse is now applied, the positive trigger from the B sweep trigger circuit is coupled through C56 to L56 and D57. C56 and L56 form a differentiating network that narrows the trigger pulse to approximately 4 nsec in width. The sharpened trigger pulse passes through D59 to tunnel diode D85 and causes D85 to switch to its high state, where it remains after the trigger pulse decays to zero. When D85 switches to its high state, Q84 is biased into saturation and the voltage change across Q84 applies

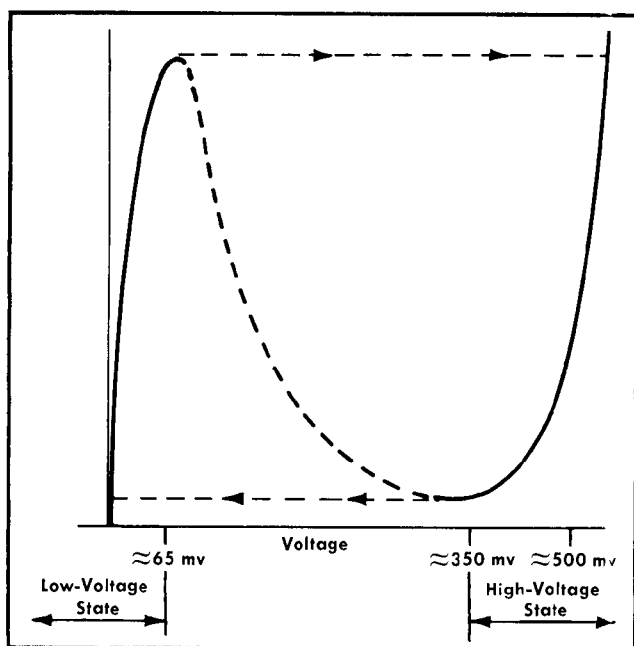

Fig. 3-2. Tunnel diode characteristics.

Circuit Description—Type 547/RM547

forward bias to Q173 and reverse biases Q89, Q103, and D86. When D86 is reverse biased, the voltage on the grid of V91 goes negative and the Miller circuit starts to run up. As the voltage on the cathode of V93A goes positive, it starts to charge timing capacitor C90 through D98. At high sweep rates, boot-strap capacitor C94 couples the rising cathode voltage to the plate circuit of V91 and effectively increases the plate supply voltage for V91, compensating for losses introduced by stray capacitance. In addition, the positive-going cathode voltage of V93A forward biases D129 and starts putting a positive voltage on the grid of V145B in the holdoff multivibrator. At a point determined by sweep-length resistor R125, the rising positive voltage biases V145B into conduction, and the holdoff multivibrator changes state, cutting off V145A. When V145A cuts off, its cathode voltage drops to -20 volts and reverse biases D85 and Q84. As current flow through Q84 ceases, the voltage increase across it again forward biases D86. When D86 becomes forward biased, it applies a positive-going voltage to the grid of V91 which resets the Miller circuit and ends the sweep.

Disconnect diode D100 ensures that the sweep starts from the same voltage point each time. Q103 is included in the circuit to reduce the amount of current that D100 has to switch, and thereby improves the linearity at the start of the sweep.

When the sweep ends, V145B has control of the holdoff multivibrator, and remains in control until the charge on holdoff capacitor C130 discharges through R130. During the time that V145B has control of the holdoff multivibrator, tunnel diode D85 cannot be triggered; but when the holdoff capacitor discharges to the point where V145A can again assume control, D85 is again biased to a point where it can accept another trigger.

Automatic Stability Circuit. Q65, Q75, and associated circuit components form a monostable multivibrator that controls the stability of the B sweep generator. When the trigger MODE switch is in the TRIG position, the switch grounds the collector of Q75 and disables the automatic stability feature of the Type 547. When the triggering MODE switch is in the AUTO STABILITY position, the sweep generator free runs if no trigger pulses are received from the trigger generator.

In normal operation, Q65 is conducting due to the positive voltage applied to its base. Q75 is normally cut off due to its base being grounded through R69. When the trigger MODE switch is set to the AUTO position, C76 starts to charge through R76. When the voltage across C76 exceeds the breakdown of Zener diode D76, D76 breaks down and provides an additional current path for tunnel diode D85. The additional current through D85 causes it to switch to its high state and start the sweep. When the sweep ends and the holdoff multivibrator switches, the voltage on the cathode of V145A drops to approximately -20 volts, reverse biasing D85. When the holdoff period ends, the cathode voltage of V145A goes slightly positive, and the current through C76 again switches D85. If no trigger is applied, the cycle repeats only if the trigger MODE switch is in the AUTO position.

When a trigger pulse is received at T52, a negative output from the secondary is applied to the base of Q65 and causes the monostable multivibrator to switch. With

Q65 now cut off, its collector voltage goes more positive, and C67 charges through R69, applying a positive voltage to the base of Q75. The positive voltage on the base of Q75 biases it to saturation, and Q75 provides a low-resistance path that discharges C76 and reverse biases D79 and D76. With the collector of Q75 below the D76 breakdown voltage, the collector circuit does not provide switching current for tunnel diode D85, so the only way D85 can be switched is by the application of a trigger pulse. If no further trigger pulses are received, Q75 is kept in saturation until the charge current for C67 decays and removes the positive voltage from the base of Q75.

During the charge time of C67, Q65 is kept cut off by the forward voltage drop across D71. When the decaying charge current removes saturation bias from Q75, the voltage drop across D71 decreases and permits Q65 to conduct, and the multivibrator switches back to its normal state. If no further trigger pulses are received, C76 charges through R76 and R75 until D76 again breaks down and provides switching current for D85.

Unblanking Circuit. With the HORIZONTAL DISPLAY switch set in the B position, an unblanking pulse is generated and applied to the crt unblanking circuit during B sweep time. The unblanking pulse is initiated when tunnel diode D85 switches to its high state and biases Q84 into conduction. When Q84 conducts, its collector voltage drops and removes the cutoff bias from Q173, biasing Q173 into conduction. When Q173 conducts, it removes the negative bias from the emitter of Q184 and the grid of V193A. The base of Q184 is negative by the amount of forward voltage drop across D182, while the emitter is positive by the amount of forward voltage drop across D183. The sum of the forward voltage drops across the two diodes is sufficient to bias Q184 into conduction. When Q184 conducts, it puts a positive-going voltage on the grid of cathode follower V195B, and the positive-going voltage is coupled to the crt-unblanking supply.

Single-Sweep Circuit. When single-sweep operation is desired, NORMAL-SINGLE SWEEP-RESET switch SW135 is set to the SINGLE SWEEP position. When SW135 is pushed to the RESET position it operates switch SW369 which discharges C369 (see A Sweep Generator schematic) through R369, R368, and R367, generating a positive pulse which is applied through C166 and D164 to the cathode of holdoff tube V145B. The positive pulse on the cathode of V145B causes the holdoff multivibrator to switch, and V145A biases sweep tunnel diode D85 to the ready point as previously explained. Since Q84 and V145B are both cut off, the positive voltage on the collector of Q84 and the voltage on the plate of V145A combine through R87 and R142 produce turn-on bias for Q89. When Q89 conducts, it completes the circuit for the NE-23 READY lamp (B89). With the application of a trigger pulse, Q84 conducts and the voltage on its collector drops, removing the bias on Q89 and thereby extinguishing the READY lamp. The runup of the Miller circuit causes the hold-off multivibrator to switch, and V145B takes control. NORMAL-SINGLE SWEEP-RESET switch SW135 applies a positive voltage through D132 to the grid of V145B, and this positive voltage prevents the holdoff multivibrator from resetting until NORMAL-SINGLE SWEEP-RESET switch SW369 has been moved to either the RESET or NORMAL position.

Main Time Base (B) Sweep Timing. The sweep rate (the rate at which the spot moves across the face of the crt) is determined by the rate at which the timing capacitor and timing resistor permit the Miller circuit to run up. By means of TIME/CM or DELAY TIME switch SW90 (see B Sweep Timing-Switch schematic), both the size of the capacitor being charged and the charging current can be selected to cover a wide range of sawtooth slopes (sweep rates). Note that SW90 is connected so that switching 8 capacitors and 6 resistors provides 24 different sweep rates, varying from 5 sec/cm to 0.1 μ sec/cm without magnification. The TIME/CM or DELAY TIME switch also selects the proper holdoff capacitor and discharge resistor for the sweep rate in use.

Continuously variable uncalibrated sweep rates are provided by R90Z and SW90Z (VARIABLE control). When SW90Z is switched to the UNCAL position, it removes the short from around R90Z and switches on UNCAL lamp B90W. By turning VARIABLE control R90Z, the charging time of the timing capacitor selected by the TIME/CM or DELAY TIME switch may be increased by a least 2.5 times the calibrated rate, providing continuously variable sweep rates.

Delay-Pickoff Circuit. The delay-pickoff circuit (see Delay Pickoff schematic) generates a trigger pulse that is delayed from the start of the B sweep by an amount determined by the settings of the Main Time Base (B) TIME/CM or DELAY TIME switch and the DELAY-TIME MULTIPLIER dial. A comparator in the delay-pickoff circuit continuously monitors the ramp output voltage of the main time base (B) Miller ramp circuit and compares the ramp voltage with a voltage level established by the setting of the DELAY-TIME MULTIPLIER dial. When the ramp voltage biases V404A into conduction, the comparator switches a tunnel diode. The tunnel diode generates a trigger pulse that is delayed from the start of the B sweep by the time it takes the ramp voltage to rise to a value approximately equal to the voltage established by the DELAY-TIME MULTIPLIER dial setting. After being amplified, the delayed trigger is applied through the HORIZONTAL DISPLAY switch as a source of delayed trigger for the time base A generator, and to the DLY'D TRIG output connector on the front panel for use in external equipment. Delayed trigger pulses are connected to the time base A sweep generator when the HORIZONTAL DISPLAY switch is in the B INTENS BY 'A', A DLY'D BY B positions, and the ALT position between the two.

In actual operation, the comparator is longtailed through a constant-current tube that keeps the current through the comparator relatively constant despite the large voltage swings applied to the grids. The grid voltage of constant-current tube V93B is fixed at approximately -56 volts by the voltage divider consisting of R406 and R407. With the grid of V93B biased at approximately -56 volts, R409 maintains the current through V93B (and thereby the comparator tube) to approximately 5 ma.

Comparator tube V404 receives the ramp output of the main time base (B) sweep generator on one grid and the voltage from the tap on delay-time helipot R416 on the other. At the start of the ramp, V404B is conducting and V404A is cut off. Assume that the ramp input to the comparator is increasing at the rate of 10 volts/msec, and the DELAY-TIME MULTIPLIER dial is set at 2.0 (2.0 is equal to 20 volts of a 100-volt ramp), then the voltage on each grid of the comparator becomes 20 volts, 2 msec after the ramp starts. At this point, V404A starts conducting. V404A draws

current through R404, L404, and tunnel diode D405. The current flow through D405 causes it to switch to its high state, generating a sharp trigger pulse. R404 and L404 narrow the hysteresis zone of D405. The low resistance of R404 would attenuate the trigger pulse if it were not for the high-frequency peaking effects of L404. The trigger voltage developed across D405 is amplified by Q424 and applied to Q433 through a differentiating network. The output of Q433 is applied to the DLY'D TRIG connector on the front panel and to the HORIZONTAL DISPLAY switch as previously mentioned.

Jack J435 provides a means of coupling in an externally-generated delayed trigger. Terminals B and C provide function information to the external trigger generator, and the externally-generated delayed trigger is applied to terminal A. It is also necessary to apply sufficient dc bias to terminal A to back bias D433.

Time Base A

Time base A in the Type 547 is very similar to the main time base (B) and the circuit description for main time base (B) generally applied to time base A. The two trigger-generator schematics, in particular, show few differences other than circuit symbols.

The major differences in the two time bases are Q344 and cathode follower V293B which appear on sweep generator A but not on B, and Q184 (the function of which is described in the discussion of main time base (B) which appears on sweep generator B but not on A. Q344 is part of the alternate-sweep lockout circuit which is explained later in this section. Cathode follower V293B is a conventional long-tailed cathode follower that provides a sample of the output of the A sweep generator to the A SWEEP front-panel output connector.

Alternate Sweep Switching Circuit

The alternate sweep switching circuit gates the desired sweep voltage to the horizontal deflection plates of the crt, provides trace-positioning voltages, and when a dual-channel vertical plug-in preamplifier is used, slaves the alternate trace multivibrator in the plug-in unit.

When the HORIZONTAL DISPLAY switch is in either ALT position, the alternate sweep switching circuit prevents B sweep from being unblanked whenever A sweep is being displayed.

Sweep Switching Multivibrator. The sweep-switching multivibrator (see Alternate Sweep Switching schematic) consisting of Q465, Q475, and associated circuit components is a conventional bistable transistor multivibrator. In alternate-sweep operation, the multivibrator is switched by the trailing edge of a sweep-gating pulse from either time base. As the sweep-gating pulse ends and starts to go positive, Q464 is biased into conduction and applies a negative-going signal to the differentiating network consisting of C459 and R459. The sharpened pulse is applied through D469 and D479 to the bases of both transistors in the multivibrator, cutting off the conducting transistor and turning on the other.

Assuming that Q465 is the conducting transistor, the resistance between its emitter and collector is quite low, effectively grounding its collector. With the collector of Q465 at ground, the voltage division across R467 and R479

Circuit Description—Type 547/RM547

applies approximately -3 volts to the base of Q475, keeping it cut off. With Q475 cut off, the voltage division across R467 and R479 applies sufficient bias to the base of Q465 to keep it saturated.

Sweep Gates. D461, D462, D471, D472, and associated circuit components form an exclusive "or" gate. With Q465 saturated and Q475 at cutoff as described in the preceding paragraph, current flow through Q465 and D461 reverse biases D462, preventing the B sweep ramp voltage from passing through D462. With Q475 cut off, its collector voltage is held at approximately $+27$ volts by Zener diode D475. This $+27$ volts reverse biases D471. The A sweep circuit then forward biases D472. D472 forward biased, the A sweep gate is open, and the A sweep ramp voltage passes through to the horizontal amplifier. When Q475 is the conducting transistor, it forward biases D471 and reverse biases D472, closing the gate for the A sweep. When Q475 conducts, Q465 cuts off and opens the B sweep gate.

Trace-Separation Amplifier. In the ALT positions of the HORIZONTAL DISPLAY switch, the collector of Q475 is connected through the switch to D482 and D492 in the trace-separation amplifier. When Q475 is cut off, D482 and D492 are reverse biased, and the operating points of V494A and V494B are determined by the setting of TRACE SEPARATION control R484. The outputs of V494A and V494B are applied to opposite sides of the push-pull vertical amplifier and position the A trace in accordance with the setting of the TRACE SEPARATION control. When Q475 is saturated (during B sweep), D482 and D492 are forward biased, effectively grounding out the positioning voltage from the TRACE SEPARATION control. Since Q475 alternates between cutoff and saturation with the HORIZONTAL DISPLAY switch in the ALT positions as explained in the preceding paragraphs, the bias on trace-separation amplifier V494 is shifted in synchronism with the alternate sweeps, thus providing trace separation.

A Sweep Terminating Circuit. When the HORIZONTAL DISPLAY switch is in B INTENS BY 'A' or the adjacent ALT position and the B sweep intensified by A sweep is being displayed, it is desirable that the A sweep be terminated not later than the end of the B sweep. When the HORIZONTAL DISPLAY switch is in either of the foregoing positions, the signal at the plate of V145A (in the B sweep-generator holdoff multivibrator) is coupled through the HORIZONTAL DISPLAY switch and C449 to the base of Q444. At the instant that the B sweep ends the B sweep-holdoff multivibrator switches, the voltage at the plate of V145A goes positive, and a differentiated positive spike is applied to Q444. The positive spike is amplified and inverted by Q444, and the now negative spike is coupled through C441 and D347 to the grid of V345B in the A sweep-holdoff multivibrator. If the A sweep-holdoff multivibrator has not yet switched and stopped the A sweep, the negative spike from Q444 triggers the sweep-holdoff multivibrator and stops the sweep. If the A sweep has not yet started, the negative pulse resets the A sweep-holdoff multivibrator.

When the HORIZONTAL DISPLAY switch is in the ALT position (between B INTENS BY 'A' and A DLY'D) some means must be used to disable the B sweep terminating pulse during the time that the delayed A sweep is being displayed. At this time, Q465 in the alternate-sweep switching multivibrator is saturated, so the B sweep terminating pulse is coupled

through D449 to the collector of Q465, where it is effectively grounded.

Alternate Trace Blanking. When the Type 547 is operated in the B INTENS BY 'A' — ALT — A DLY'D mode, it is necessary to keep the B sweep unblanking circuit cut off during the part of the sweep-switching cycle in which only the delayed A sweep is displayed. Cutoff is accomplished by applying the positive A sweep-gating voltage from the collector of Q475 to the base of Q184. When the HORIZONTAL DISPLAY switch is in either ALT position, the A sweep-gate voltage taken from the collector of Q475 is applied through the switch to D481. When the A sweep-gate voltage is positive, D481 is forward biased, and applies the positive voltage through R181 to the base of Q184. The positive voltage applied to the base of Q184 during the time that the A sweep gate is open is sufficient to keep Q184 cut off despite the unblanking signal from Q173.

Alternate-Sweep Lockout and Blanking Circuits

When alternate A and B sweeps are to be displayed, the horizontal amplifier and the crt must be time-shared between the two displays. Alternate-sweep lockout and blanking circuits are employed to ensure that the sweeps are displayed in proper sequence. The operations of the circuits for each position of the HORIZONTAL DISPLAY switch are described in the following paragraphs.

A Position. In this position of the HORIZONTAL DISPLAY switch, only the A sweep is displayed. The main time base (B) generator is blanked out by grounding the collector of Q465 in the alternate-sweep switching circuit. In the A position of the HORIZONTAL DISPLAY switch (SW530), the collector of Q564 is grounded through terminals 1 and 5 of wafer 8F. Grounding the collector of Q465 closes the B sweep gate composed of D461 and D462. With the B sweep gate closed, any output from the main time base (B) generator does not get through to the horizontal amplifier.

B Position. This position of the HORIZONTAL DISPLAY switch grounds the collector of Q475, closing the A sweep gate composed of D471 and D472. In this case, the output of the A sweep generator is prevented from reaching the horizontal amplifier.

A—ALT—B Position. When the HORIZONTAL DISPLAY switch is placed in the ALT position midway between A and B, the horizontal amplifier and crt must be time-shared between the two time-base sweep generators. Note that in this position of the HORIZONTAL DISPLAY switch, the collector of Q475 is connected through D133 and terminals 9 and 11 of wafer 4R to the B sweep-holdoff multivibrator. Likewise, the collector of Q465 is connected through terminals 3 and 10 of wafer 4F to the holdoff circuit of A sweep-holdoff multivibrator. This means that at the instant of turn on, the nonconducting transistor of the alternate-sweep switching multivibrator permits a lockout voltage to be applied to the holdoff multivibrator to which it is connected. The switching inputs to the sweep-switching multivibrator are taken from the plate of V345B in the A sweep-holdoff multivibrator, and from the plate of V145A in the B sweep-holdoff multivibrator. If, at the instant of turn on, no triggering signals are being applied and both TRIGGERING MODE switches are in the TRIG position, there is no sweep. Under

these conditions, if Q465 in the alternate-sweep switching multivibrator is the conducting transistor, the main time base (B) sweep generator is locked out and cannot be triggered until A sweep generator has been triggered. If a trigger is now applied to the A sweep generator, it runs up, its hold-off multivibrator switches, and a switching signal is sent by the holdoff multivibrator to the alternate-sweep switching multivibrator via Q464. B sweep can now be triggered. If Q475 is the conducting transistor at the moment of turn on, and the TRIGGERING MODE switches are in the TRIG position, then the A sweep generator cannot be triggered until the main time base (B) has been triggered.

B INTENS BY 'A' Position. In this position of the HORIZONTAL DISPLAY switch and with the TRIGGERING MODE switch in the TRIG position, the pulse from the delay-pickoff circuit switches the A sweep-holdoff multivibrator, but the sweep waits for a trigger before starting to run up. When the A sweep generator completes its runup and goes into holdoff, this fact is signaled to the main time base (B) generator by Q344. The conduction of V345A during the A sweep-holdoff time is sufficient to reverse bias D356, cutting off Q344. Cutting off Q344 permits the voltage at the junction of R135 and R136 to go more positive, keeping the main time base (B) sweep generator locked in holdoff. As the holdoff capacitor in the A sweep generator discharges, the voltage on the grid of V345A falls, decreasing the current flow through V345A. When the holdoff capacitor in the A sweep generator is finally discharged, the current flow through V345A has decreased to where D356 is no longer reverse biased, and Q344 conducts, removing the lockout voltage from the main time base (B) generator holdoff multivibrator. The main time base (B) generator resets and is triggerable.

B INTENS BY 'A' —ALT — A DLY'D Position. In this position of the HORIZONTAL DISPLAY switch, the alternate-sweep switching multivibrator alternately gates A sweep delayed by B and B sweep intensified by A into the horizontal amplifier. Note that in this mode of operation the main time base (B) generator sends a sweep-terminating pulse to the A sweep-generator holdoff circuit at the end of the intensified B sweep, and that A sweep-generator holdoff multivibrator keeps the main time base (B) sweep generator locked out (in holdoff) until the A sweep generator has completed its holdoff period and is triggerable. The foregoing actions can be determined by tracing the signals through wafers 7R, 8F, 8R, 4F, 4R, 2R, and 1F of the HORIZONTAL DISPLAY switch.

B INTENS BY 'A' Position. In this mode of operation, the collector of Q475 in the alternate-sweep switching multivibrator is grounded through the contacts of wafer 8R, and the A sweep gate is closed. Contacts 5 and 10 of wafer 4F apply a positive voltage to the grid of V345A in the A sweep-holdoff multivibrator. The positive voltage on the grid of V345A assures that the A sweep generator will stay in holdoff until the delayed trigger pulse from the delay-pickoff circuit overrides the holdoff voltage and resets the holdoff multivibrator. If the TRIGGERING MODE switch is in the TRIG position, runup of the A sweep generator does not commence until a trigger is received from the A sweep-trigger circuit. At the end of the B sweep, Q444 in the alternate-sweep switching circuit sends a termination pulse to the grid of V345B (in the A sweep-generator holdoff multivibrator) that resets the holdoff multivibrator and terminates the A sweep.

A DLY'D Position. In this position of the HORIZONTAL DISPLAY switch, the collector of Q465 in the alternate-sweep switching multivibrator is grounded, closing the B sweep gate. The A sweep-generator holdoff multivibrator is kept in holdoff by a positive voltage applied through wafer 4F of the HORIZONTAL DISPLAY switch, and, as in the case where the B sweep is intensified by the A sweep, can be brought out of holdoff only by a reset pulse from the delay-pickoff circuit. When the HORIZONTAL DISPLAY switch is in the A DLY'D position, the action starts when the main time base (B) generator receives a trigger and starts its runup. After a period of time selected by the DELAY-TIME MULTIPLIER dial, the delay-pickoff circuit generates a pulse that takes the A sweep generator out of holdoff. If the TIME BASE A-TRIGGERING-MODE switch is in the AUTO STABILITY position, the A sweep generator starts its runup.

Alternate-Trace Sync Amplifier

The alternate-trace sync amplifier (see Interconnecting Jack J11 schematic) amplifies and shapes the alternate-trace sync pulses and applies them to the vertical plug-in preamplifier, provides a sample of the pulse to the crt for blanking purposes, and amplifies the chopped blanking pulses from the vertical plug-in preamplifier for application to the crt.

Horizontal Amplifier

The dc-coupled horizontal amplifier (see Horizontal Amplifier schematic) consists of a transistor input amplifier, an emitter follower, a transistor paraphase amplifier, a push-pull vacuum-tube output amplifier, a pair of output cathode followers, and a capacitance-driver tube. In addition, the Type 547 contains a cathode-coupled preamplifier that is used to amplify externally applied horizontal deflection signals. The input to the horizontal amplifier is received from either the alternate-sweep switching circuit or the external HORIZ INPUT connector, depending upon the setting of the HORIZONTAL DISPLAY switch.

Input Stages. The selected input signal is applied to the base of Q534 along with dc-positioning voltages from the horizontal positioning controls. The composite signal output of Q534 is applied to emitter follower Q543, and from that transistor to the paraphase amplifier. Negative feedback from the emitter of Q543 to the base of Q534 keeps the input and output impedance of the two stages low. R544 in the feedback loop provides a means of adjusting the amount of feedback, thereby providing amplifier gain adjustment.

Paraphase Amplifier. Q554, Q564, and associated circuit components form a paraphase amplifier that splits the signal from Q543 into push-pull output. The signal from Q554 to Q564 is coupled through the emitter circuit, and by changing the value of the coupling resistor, the gain of the paraphase amplifier is changed to provide sweep magnification. Four selectable values of coupling resistor are available providing X1, X2, X5, or X10 sweep magnification.

The feedback loop from the collector of Q554 stabilizes the gain and balance of the paraphase amplifier. D542 and D561 provide base-operating bias. The feedback loops from the output cathode followers (V574B and V584B) to the emitters of Q554 and Q564 assist in stabilizing the gain of the horizontal amplifier.

Circuit Description—Type 547/RM547

Output Amplifier and Cathode Followers. The ramp-voltage outputs of the paraphase amplifier are applied to the grids of amplifiers V574A and V584A. The ramp voltages are amplified by the two triodes, which then apply the ramp voltages to the output cathode followers. To maintain the desired linearity at high sweep rates, part of the output from each amplifier is bypassed around the cathode followers through small variable capacitors C572 and C582. C576 and C586 together with stray capacitance across R576 and R586 form a capacitance bridge to provide correct high-frequency feedback.

Capacitance Driver. The cathode of V574B drives the left-hand deflection plate and, during the sweep, the cathode voltage should go linearly in a negative direction. At high sweep rates, when V574B tries to drive the deflection plate negative, the deflection-plate capacitance and the output capacitance of cathode follower V574B tend to distort the ideal linear ramp voltage into an rc discharge curve. To overcome this tendency toward nonlinearity, the positive-going ramp voltage at the cathode of V584B is applied through C591 to the grid of capacitance driver tube V589. The positive-going voltage on the grid of V589 forces it into heavy conduction, and the current supplied through the tube provides extra current to the cathode of V574B and helps to discharge the capacitance in the output of V574B. Since the crt is blanked during the return trace, there is no need for a similar current driver at the cathode of V584B.

External Horizontal Preamp. The preamplifier applies external horizontal deflection voltages through the HORIZONTAL DISPLAY switch to the grid of V514B. For large-amplitude signals, a X10 attenuator position is provided on the HORIZONTAL DISPLAY switch. V514B and V514A form a cathode-follower grounded-grid amplifier, with the gain controlled by adjusting the value of the coupling resistor between the two cathodes. In this case, R511 provides at least a 10:1 range of adjustment. The output of V514A is applied through the HORIZONTAL DISPLAY switch to the base of Q534.

Amplitude Calibrator

The amplitude calibrator in the Type 547 is a 1-kc square-wave generator (see Amplitude Calibrator schematic) that provides both voltage and a 5-ma current output to the front-panel connectors. The voltage output is taken from the CAL OUT connector on the front panel, where either a selectable-amplitude squarewave or a steady +100-volt dc

reference voltage is available. By turning the AMPLITUDE CALIBRATOR switch, the amplitude of the square-wave output may be varied from 0.2 mvolt to 100 volts peak-to-peak. The current output is applied to the link marked 5 mA Ω , with the arrow indicating conventional current flow. When the AMPLITUDE CALIBRATOR switch is in the 100 V DC position, the link has 5 ma dc flowing through it; when the switch is in the 5 mA Ω position, the current through the link is in the form of a 1-kc, 5 ma square wave.

CAUTION

The link is designed for use with a snap-on current probe and does not unplug.

Square-Wave Generator. The square-wave generator is an astable multivibrator direct-coupled to a cathode follower. V935A and V945 are the multivibrator tubes, with the screen of V945 serving as an anode and furnishing feedback to V935A. The plate of V945 operates as an electron-coupled amplifier. The time constants in the grid circuits of the tubes are different to compensate for the difference in their characteristics. When the amplitude calibrator is turned on, the multivibrator cathodes are returned directly to the dc-coupled -150-volt supply. Since the plate load and grid resistors are grounded, this means that the supply potential of the multivibrator is 150 volts. The plate of V945 operates from the +225-volt supply, but is clamped slightly above 100 volts by D942 and D948. The voltage on the plate of V945 swings from about -30 volts to about +102 volts. The plate of V945 is coupled through Zener diode D948 to the grid of cathode follower V935B. CAL AMPL control R943 is adjusted so that when the signal to V935 is positive, its cathode voltage rises to +100-volts. When the signal from the V945 plate goes negative, V935B is cut off and the cathode voltage goes to ground potential.

Output Level Selection. The cathode load for V935B is essentially the string of precision resistors starting with R950 and ending with R958. The junctions of the precision resistors are connected to the CAL OUT connector through AMPLITUDE CALIBRATOR switch SW950. The values of the precision resistors are selected to give output amplitude steps in multiples of 1, 2, or 5. In the steps from 200 mvolts to 100 volts, the junctions of the precision resistors are switched through R962 to the CAL OUT connector, while in the steps from 0.2 to 100 mvolts, an additional divider with a ratio of 1000:1 is inserted between the precision resistors and the CAL OUT connector. In the 0.2 mvolt to 200 mvolt range, the output impedance is 50 Ω .

SECTION 4

MAINTENANCE

PREVENTIVE MAINTENANCE

CAUTION

Turn off power before removing or replacing parts.

General Information

The Type 547 is a stable instrument and will provide many hours of trouble-free operation. However, to maintain measurement accuracy, a visual inspection and a calibration check should be made after each 500 hours of operation or every six months if used intermittently. The calibration procedures include steps for checking the operation of various circuits. Minor troubles not apparent during regular operation will often be revealed during calibration. Major troubles in the instrument are often isolated or eliminated by recalibrating the instrument.

Visual Inspection

The Type 547 should be inspected occasionally for such defects as broken connections, broken or damaged ceramic strips, improperly seated tubes or transistors, and heat-damaged parts.

The remedy for most visible defects is obvious; however, particular care must be taken if heat-damaged parts are detected. Overheating is usually only a symptom of trouble. For this reason, it is essential to determine the actual cause of overheating before the heat-damaged parts are replaced; otherwise, the damage may be repeated.

Cleaning

The Type 547 must be cleaned as often as operating conditions require. Accumulations of dirt in the instrument can cause overheating and component breakdown. Dirt on the components acts as an insulating blanket (preventing efficient heat dissipation) and provides conducting paths for electricity. Dirt in the air filter chokes the flow of cooling air and leads to excessive operating temperature.

Air Filter. The air filter should be visually checked every few weeks and cleaned if dirty. More frequent inspections and cleaning are required under severe operating conditions. To clean the filter, wash it out as you would a plastic sponge. Rinse the filter and let it dry. Coat the dry filter with fresh "Filter-Kote" (Tektronix art Number 006-580) or "Handi-Koter". (These products are available from the local representative of the Research Products Corporation, and from some air-conditioner suppliers.) Let the filter dry thoroughly before reinstalling.

Exterior. Loose dust accumulating on the outside of the Type 547 can be removed with a cloth or small paint brush. The paint brush is particularly useful for dislodging dust on and around the front-panel controls. Stubborn dirt can be

removed with a soft cloth dampened in a mild solution of water and detergent. Abrasive cleaners should not be used.

Clean the face of the crt with a soft, lint-free cloth dampened with denatured alcohol.

Interior. Although the air entering the Type 547 is filtered, some dust will eventually penetrate into the interior of the instrument. This dust should be removed occasionally due to its conductivity under high humidity conditions. The best way to clean the interior of the equipment is to first carefully vacuum all accessible areas and then blow away the remaining dust with dry low-pressure compressed air. Avoid the use of high-velocity air which might damage some of the components. Remove stubborn dirt with a soft paint brush or a cloth dampened with a mild water and detergent solution.

Pay special attention to high-voltage circuits, including parts inside the high-voltage shield. Arcing in the high-voltage circuits due to dust or other causes may produce false sweep triggering resulting in an unstable crt display.

Lubrication

The fan motor bearings should be lubricated every three or four months with a few drops of light machine oil (see Fig. 4-1). Failure to lubricate the bearings periodically can cause the fan to slow down or stop.

CORRECTIVE MAINTENANCE

General Information

Many components in the Type 547 are mounted in a particular way to reduce stray inductance and capacitance. While removal or replacement procedures for most parts in the Type 547 are obvious, remember to duplicate lead length, lead dress, and location of the original component when installing replacement parts. Since components of the same type may exhibit slightly different characteristics, it is desirable to check the calibration of the Type 547 after completion of repairs.

Component Numbering

The component number of each electrical part is shown on the circuit diagrams. The following chart lists the component numbers associated with each circuit:

Numbers less than 100 — B Sweep Trigger Circuit
100 — series numbers — B Sweep Generator
200 — series numbers — A Sweep Trigger Circuit
300 — series numbers — A Sweep Generator Circuit
400 — series numbers — Alternate-Sweep Switching Circuit
500 — series numbers — Horizontal Amplifier Circuit
600 — and 700 — series numbers — Low-Voltage Power
800 — series numbers — Crt Circuit
900 — series numbers — Calibrator
1000 — and 1100 — series numbers — Vertical Amplifier



Fig. 4-1. Fan motor lubrication points.

Soldering Precautions

In the production of Tektronix instruments, a special silver-bearing solder is used to establish a bond to the ceramic terminal strips. This bond may be broken by repeated use of ordinary tin-lead solder, or by excessive heating of the terminal strip with a soldering iron. Occasional use of ordinary 60-40 solder will not break the bond unless excessive heat is applied, but it is advisable to stock solder containing about 3% silver for the maintenance of Tektronix instruments. This solder may be purchased directly from Tektronix in one-pound rolls; order by Part Number 251-514.

Because of the shape of the ceramic-strip terminals, it is recommended that a soldering iron with a wedge-shaped tip be used. A wedge-shaped tip allows the heat to be concentrated on the solder in the terminals and reduces the amount of heat required. It is important to use as little heat as possible while producing a full-flow joint.

The following procedure is recommended for removing or replacing components mounted on ceramic strips:

1. Use a 50- to 75-watt soldering iron.
2. Tin the tip with solder containing about 3% silver.
3. Use long-nose pliers for a heat sink. Attach pliers between the component and the point where heat is applied.
4. Apply heat directly to the solder in the terminal without touching the ceramic. Do not twist the iron in the notch as this may chip or break the ceramic strip.

5. Apply only enough heat to make the solder flow freely.
6. Do not attempt to fill the notch on the strip with solder; instead apply only enough solder to cover the wires adequately and form a small fillet on the wire. Overfilling the notches may result in cracked terminal strips. If the lead extends beyond the solder joint, clip the excess as close to the joint as possible. Remove all wire clippings from the chassis.

Tubes and Transistors

Tubes or transistors should not be replaced unless they are actually defective. If tubes or transistors are removed and found to be acceptable, be sure to return them to their original sockets. Tube or transistor-tester checks on the tubes or transistors used in the Type 547 are not recommended. Testers may indicate a tube or transistor to be defective when it is operating satisfactorily in a circuit, or may fail to indicate tube or transistor defects which affect the performance of the circuits. It is recommended that tubes and transistors be checked by substitution. If the tube or transistor is good, return it to its socket. Unnecessary replacement of tubes or transistors is not only expensive but may also result in needless recalibration of the instrument.

When installing replacement transistors on heat sinks in the instrument, the bottom of the transistor where it contacts the heat sink should be coated with silicone grease. If a heat sink has been replaced along with the transistor, then that area of the heat sink which contacts the chassis of the instrument should also be coated with silicone grease.

Wafer Switches

Individual wafers are normally not replaced in the switch assemblies. If one wafer is defective, the entire switch assembly should be replaced. Switches can be ordered from Tektronix either wired or unwired. Refer to the parts list in Section 6 for wired and unwired switch part numbers.

The wafer switches shown on the schematics are coded to indicate the position of the wafer on the switch. The wafers are numbered from front to rear (i.e., the number 1 wafer is always closest to the front panel). The letters F and R indicate the front or rear of the wafer. For example, code designation of 3R means the rear side of the third wafer from the front panel.

Cathode-Ray Tube

To remove and replace the cathode-ray tube, perform the following procedure:

WARNING

Be careful when handling a crt. Avoid striking it on any object that might cause it to crack and implode. Flying glass from an imploding crt can cause serious injury. Use safety glasses or a plastic face mask for protection.

1. Remove the crt bezel nuts, bezel, and plastic polarized light filter (see Fig. 4-2).
2. Remove plastic eyebrow and retaining spring from the top of the crt (see Fig. 4-2).

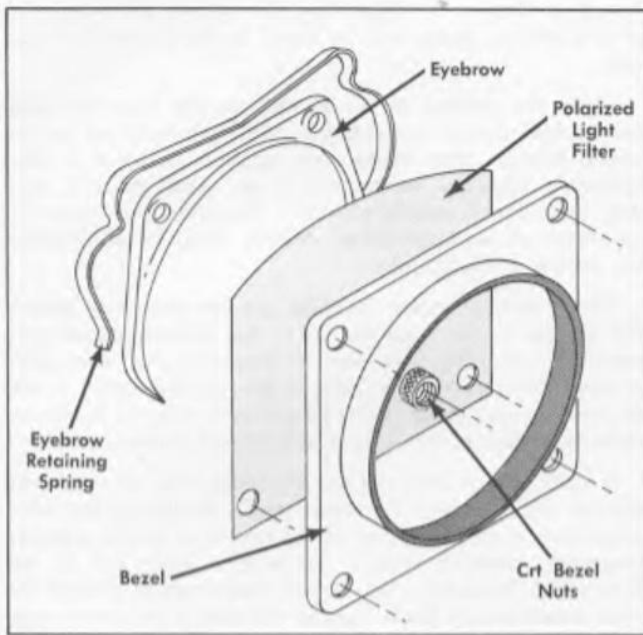

Fig. 4-2. Crt bezel and eyebrow arrangement.

- Remove crt anode lead, disconnect all leads to the neck of the crt.

NOTE

Do not disconnect the crt trace-rotation coil leads.

- Using a Phillips screwdriver, loosen crt base clamp (see Fig. 4-3).
- With your left hand, wiggle the crt socket (see Fig. 4-3) to ensure that the base of the crt is loose in the base clamp.
- With a chisel-tipped plastic or wooden dowel, carefully work the crt socket loose from the crt base.
- Grasp the face of the crt with the right hand. Push the crt carefully towards the front of the Type 547 with the left hand. Be careful not to bend the neck pins. Remove the crt through the front of the oscilloscope.
- Before reinstalling the crt, dust talcum powder on the crt base. This keeps the base of the crt from sticking to the neoprene bushing inside the base clamp.
- Carefully insert the new tube into the shield and the tube base clamp. Keep the anode button in line with the anode connector hole so that the button is aligned with the hole when the crt is fully inserted.

NOTE

Make sure that the crt base clamp is loose enough to permit the crt base to slide through the neoprene bushing inside the base clamp.



Fig. 4-3. Loosening the crt base clamp.

- Connect the tube socket to the tube base. Check that the socket is fully seated.
- Align the crt so that the horizontal graticule lines are parallel with the top of the front panel. Push the crt inward until the crt face protrudes exactly $\frac{3}{16}$ " beyond the front panel.

NOTE

If the crt face is not parallel with the front of the oscilloscope, use a $\frac{7}{64}$ " hexagonal wrench to loosen the two mounting screws that fasten the base clamp to its mounting bracket (see Fig. 4-3). The base clamp and crt base may now be moved radially to align the face of the crt parallel with the front of the oscilloscope.

- Reconnect the anode and neck pin leads (observe color code).
- Install eyebrow and eyebrow retainer spring. Align the crt so that the front surfaces of the light pipe and eyebrow are flush.
- Tighten the base clamp.
- Turn on the oscilloscope. Obtain a free-running sweep on the crt.

Maintenance—Type 547/RM547

16. Check the alignment of the trace with the graticule lines. If the trace is not parallel with the graticule lines, align the trace with the TRACE ROTATION control.
17. Replace plastic polarized light filter, crt bezel and bezel nuts.

Graticule Lamps

Proper illumination of the crt graticule depends upon the proper positioning of the graticule lamps. When replacing graticule lamps, slide the lamp and sockets in or out until the filament of the lamp is at the middle of the light pipe thickness.

Ceramic Terminal Strips

To remove a ceramic terminal strip, first unsolder all leads and components connected to it. Use diagonal cutters to cut off one side of each stud holding the strip. This frees the strip, and the remainder of the stud can then be pulled free of the chassis with a pair of pliers. The spacers may come out with the studs; if not, they can be pulled out separately. If they are not damaged, the spacers may be used with the new strip assembly. Ceramic strips are supplied with studs attached, so it is not necessary to salvage the old studs.

After removing a damaged strip and stud assembly, place the spacers into the holes in the chassis and insert the studs into the spacers. Be sure the studs are completely seated in the spacers. If necessary, use a soft-faced mallet to tap the studs into the spacers. Tap the studs in equal increments to prevent strains on the ceramic strip. Fig. 4-4 shows the assembled ceramic strip.

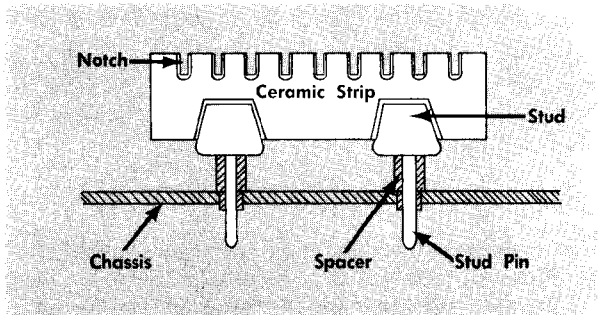

Fig. 4-4. Ceramic strip assembly.

Troubleshooting Techniques

If the instrument is not operating, first check that the power cord is plugged in and that there is power at the socket. Then check that the pilot lamp and tube heaters are lit. If necessary, check the line fuse.

Attempt to isolate the trouble by a quick operational and visual check. Make sure that any apparent trouble is actually due to a malfunction within the instrument and not to improper control settings or to a faulty plug-in unit or probe. Instructions for the operation of the Type 547 and general information concerning plug-in operation are con-

tained in Section 2. Operating instructions for a specific plug-in unit or probe will be found in the manual for that unit.

Check the settings of all controls on the Type 547 and the vertical plug-in preamplifier unit. A control set to the wrong position may cause what appears to be a trouble symptom. Operate the controls to see what effect, if any, they have on the trouble symptom. The normal or abnormal operation of each particular control helps in establishing the nature of the trouble.

When vertical-system troubles are encountered, isolate the trouble to the Type 547 or to the vertical plug-in preamplifier unit. The best way to determine this is by substituting another vertical plug-in preamplifier unit. If the trouble appears to be in the plug-in unit, refer to the Maintenance section of the plug-in unit instruction manual.

If other plug-in units are not available, and the symptoms are not definite, check the power-supply resistances and voltages since a failure in one of the regulated power supplies frequently presents unusual symptoms. Table 5-2 in the Calibration Procedure lists normal resistances to ground for each power-supply lead. Typical voltages in the power supplies are shown on the power-supply schematic. The voltages shown may vary slightly from instrument to instrument.

All wiring used in the Type 547 is color coded to facilitate circuit tracing. In addition, all regulated power-supply leads are coded with specific color combinations for easy identification. In general, three stripes are placed on the wires of the regulated supplies. The code used is the standard EIA number-color code. The first color (widest stripe) indicates the first number of the voltage on that lead. The second color indicates the second number of the lead voltage, and the third color is a multiplier. The method is similar to that used in color coding resistors. Thus, the +100-volt leads are coded brown, black, brown. The voltage is positive if the body color of the wire is white and negative if the body color of the wire is tan.

Reference voltage for the regulated supplies is obtained from the -150-volt supply. If it is not operating properly, the other low-voltage supplies will be affected. For this reason, the -150-volt supply should be checked first when trouble is suspected in the low-voltage supplies. If the output of the -150-volt supply is correct, then check the outputs of the other supplies.

Most troubles that might occur in Tektronix instruments result from the failure of vacuum tubes or semiconductors. Once the trouble has been isolated to a particular area or circuit, check the tubes and semiconductors in the trouble area. It is preferable to check them by substitution rather than with a tester, since testers frequently fail to indicate certain troubles which can affect oscilloscope performance. Remember that when tubes or semiconductors fail, associated circuit components can be damaged.

Circuit Troubleshooting

The Type 547 consists of ten main circuits plus the Calibrator and Alternate-Trace Sync Amplifier circuits. The ten main circuits are the:

1. Low-Voltage Power Supply

2. Crt Circuit (including the High-Voltage Power Supply)
3. Vertical Amplifier and Delay Line
4. Main Time Base (B) Sweep Trigger Circuit
5. Main Time Base (B) Sweep Generator
6. Time Base A Sweep Trigger Circuit
7. Time Base A Sweep Generator
8. Delay-Pickoff Circuit
9. Alternate-Sweep Switching Circuit
10. Horizontal Amplifier

The crt display can often be used to identify a defective circuit. For example, if there is no vertical deflection when the intensity and horizontal deflection appear normal, the trouble can be open signal connections, no signal source, the

plug-in unit or even loose crt connections. Other abnormal characteristics in the crt display similarly point to a defective circuit or group of circuits.

Once the nature and approximate location of the trouble has been determined, further isolate the trouble by performing the steps in the calibration procedure for the circuits in which trouble is suspected. The voltages and waveforms to be expected in each circuit are shown on the schematics. Refer to Section 3 for an explanation of the operation of the defective circuit.

IMPORTANT

When it is desired to operate the plug-in unit from a plug-in extension, the plug-in sensing switch (SW673, located at the top rear of the plug-in compartment) must be manually operated. To manually operate the switch, pull the plastic plunger outward to the stop position.

SECTION 5

CALIBRATION

Introduction

The Type 547 Oscilloscope is a stable instrument which will provide many hours of trouble-free operation. However, to ensure measurement accuracy, it is suggested that you recalibrate the instrument after each 500 hours of operation or every six months if used intermittently. It will also be necessary to recalibrate certain sections of the instrument when tubes, transistors, or other components are replaced.

The steps in the following procedure are arranged in the proper order for complete recalibration to avoid unnecessary repetition.

This procedure is a combination performance check and adjustment procedure. The first portion of the step title refers to the name of the check or adjustment and the last portion of the title is the name of the circuit diagram affected by the step or on which the adjustment is located, whichever is applicable.

Figs. 5-5, 5-8, 5-11, 5-14, and 5-17 are oscilloscope front-panel illustrations that show the control settings, signal connections and signal input (if any) at those particular points in the procedure. These illustrations serve two purposes: (1) as an aid to quickly check your own setup, and (2) to enable you to start in the "middle" of the procedure when it is necessary to recalibrate a certain portion of the instrument. For example, Fig. 5-5 shows the front-panel setup at the completion of step 12e. Using this same setup as illustrated, this can be the starting point for recalibrating the A Sweep Trigger circuit. Fig. 5-5 can also be used as an aid when determining the setup needed for starting the recalibration of the B Sweep Trigger circuit. Unless otherwise stated, all resistances and voltages are measured with respect to chassis ground.

Equipment Required

The following equipment or equivalent is necessary for complete calibration of the Type 547 Oscilloscope:

- Low-Bandwidth Test Oscilloscope with a X1 attenuator probe. Description: Bandwidth, dc to 300 kc or better; calibrated vertical deflection factor of 5 mv/cm. Purpose: To check low-voltage power supply output ripple amplitude.
- Test load unit, Tektronix Type TU7 (067-0521-00). Contains a pulse generator capable of producing pulses with a risetime of 3 ns or faster. This multi-purpose test-

NOTE

Whenever the TU-7 (067-0521-00) REPETITION RATE switch is referred to, the following switch positions should be considered equivalent for test purposes:

TU-7 (067-0521-00)	067-0521-01
LOW	4 kHz
MED	80 kHz
HIGH	500 kHz

load unit is the only plug-in needed to perform a complete calibration of the Type 547 Oscilloscope.

- Time-Mark generator, Tektronix Type 180A. Markers required at 1 and 5 sec, 500, 100, 10, 5, and 1 msec, 500, 100, 50, 10, 5, and 1 μ sec, 5, 10, and 50-mc sine waves. 10- μ sec trigger pulse output required. All outputs must have a time accuracy of at least 0.1%.
- VOM (Volt-Ohm-Milliammeter) Dc sensitivity of at least 20,000 ohms per volt. Calibrated for an accuracy of at least 1% at -150, +100, +225, and +350 volts, at least 5% at -1850 volts.
- Variable autotransformer (e.g. Powerstat or Variac). Required specifications: A rating of at least 600 volt-amperes with an output voltage range covering the operating range of the oscilloscope under test.
- Rms-calibrated ac voltmeter. Required specifications: A range of 0-150 volts (0-300 volts if the oscilloscope is wired for 234-volt nominal line-voltage operation).
- Two coaxial cables, 50-ohm nominal impedance, 42" long with BNC plug-connectors on each end. Tektronix Part No. 012-057.
- Power cord adapter for connecting the 3-wire oscilloscope power cord to a 2-wire receptacle. Tektronix Part No. 103-013.
- Adapter, single binding post fitted with a BNC plug. Tektronix Part No. 103-033.
- Coaxial connector adapter with BNC-jack and UHF-plug connector fittings. Tektronix Part No. 103-015.
- Jumper clip lead, about 4" long. Equipped with miniature alligator clips on each end.
- Two interconnecting leads, 18" long, with combination plug-and-jack banana-type connectors on each end. Type PC-18R. Tektronix Part No. 012-031.
- BNC T connector. Fits one BNC jack and accepts two BNC plugs. Tektronix Part No. 103-032.
- Miscellaneous Items
 - Screwdriver, $\frac{3}{16}$ " wide bit, shank about 3" long.
 - Screwdriver, $\frac{3}{32}$ " wide bit, shank about 2" long.
 - Jaco No. 125 insulated low-capacitance-type screwdriver with a $1\frac{1}{2}$ " long shank and $\frac{1}{8}$ " wide metal tip. Total length is 5". Tektronix Part No. 003-000.
 - Low-capacitance alignment tool consisting of a handle (Tektronix Part No. 003-307), a gray nylon insert with a metal screwdriver tip (Tektronix Part No. 003-334), a $\frac{5}{64}$ " hexagonal wrench insert (Tektronix Part No. 003-310).
 - Hexagonal wrench, $\frac{1}{16}$ ". For repositioning, if necessary, the TRIGGERING LEVEL control knobs.

PRELIMINARY PROCEDURE

- Remove the oscilloscope from the cabinet.

Calibration—Type 547/RM547

2. Insert the Type TU-7 in the oscilloscope vertical plug-in compartment. Set the Type TU-7 Test Function switch to the Low Load position.
3. Lay the oscilloscope on its left side for access to the bottom of the instrument.
4. Using the VOM, check the resistance from the regulated power-supply terminals to ground as shown in Fig. 5-1. The values of resistance should be approximately as indicated in Table 5-1, once the capacitors are charged by the VOM internal battery.

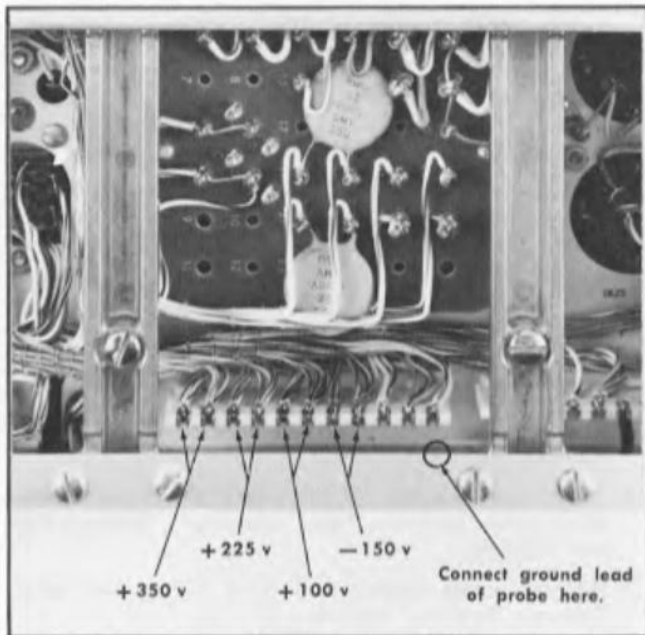

Fig. 5-1. Low-voltage power supply test point locations.

TABLE 5-1

Power Supply Lead	Resistance to Ground
-150 volts	1 k to 2 k
+100 volts	1 k to 2 k
+225 volts	2 k to 3 k
+350 volts	25 k to 35 k

5. Check the fuse at the rear of the instrument for correct value.
6. Connect the instrument and ac voltmeter to the autotransformer output. Connect the autotransformer to the power line.
7. Turn the INTENSITY control on the instrument fully counterclockwise and turn on the power to all the equipment. Adjust the autotransformer output voltage to 115 volts (or the design-center voltage for which the instrument is wired).
8. Set the oscilloscope front-panel controls to the positions listed in Table 5-2.

TABLE 5-2

	Crt Controls
INTENSITY	0
FOCUS	As is

ASTIGMATISM	As is
SCALE ILLUM	5
TRACE SEPARATION	0

Time Base A

TRIGGERING LEVEL	Fully counterclockwise and pushed in
TRIGGERING MODE	TRIG
SLOPE	+
COUPLING	AC
SOURCE	NORM INT
VARIABLE (TIME/CM)	CALIBRATED
TIME/CM	.5 mSEC

Horizontal Display

HORIZONTAL DISPLAY	A
SWEEP MAGNIFIER	×1 OFF
Single Sweep Switch	NORMAL

Main Time Base (B)

TRIGGERING LEVEL	Fully counterclockwise and pushed in
TRIGGERING MODE	TRIG
SLOPE	+
COUPLING	AC
SOURCE	NORM INT
VARIABLE (TIME/CM)	CALIBRATED
TIME/CM	.5 mSEC
BRIGHTNESS	Fully clockwise

Other Controls

DELAY-TIME MULTIPLIER	1.00
HORIZONTAL POSITION	Midrange
VERNIER (HORIZONTAL POSITION)	Midrange
AMPLITUDE CALIBRATOR	OFF

9. Set the Type TU-7 front-panel controls as follows:

Vertical Position	Centered
Test Function	Low Load
Other Controls	As is
10. Allow about five minutes for warmup. Check that the EXT CRT CATHODE-to-GND shorting strap is in place on the terminals, and the CRT CATHODE SELECTOR switch is set to the EXTERNAL CRT CATHODE position.
11. Recheck the autotransformer output for proper design-center voltage as soon as the instrument has warmed up.

CHECK AND ADJUSTMENT PROCEDURE

1. Check Voltage Accuracy—Power Supply

- a. Establish the conditions described previously under "Preliminary Procedure".

b. Check the voltage accuracy of each power supply output using the VOM according to the information given in Table 5-3. The location of the test points is shown in Fig. 5-1.

TABLE 5-3

Power Supply	Tolerance	Maximum Peak-to-Peak Ripple
-150 v	-147 to -153 v	10 mv
+100 v	+98 to +102 v	15 mv
+225 v	+220.5 to +229.5 v	10 mv
+350 v	+343 to +357 v	25 mv

c. If necessary, adjust -150 VOLTS R616 (see Fig. 5-2) so all power supply voltages are within tolerance.

NOTE

Do not adjust the -150 VOLTS control unless one or more of the supplies is actually out of tolerance. Remember that the calibration of the entire instrument is affected by changes in the power supply voltages and all the positive volt-

age power supplies depend upon the -150-volt supply output accuracy.

2. Check Regulation and Output Ripple—Power Supply

NOTE

When checking for proper regulation of the power supplies at the lower line-voltage limit, the ac line voltage should contain no more than 3% distortion.

- a. Monitor the regulated output of the -150-volt supply with the VOM. The test point location is shown in Fig. 5-1.
- b. Connect the $\times 1$ probe form the test oscilloscope to the -150-volt test point and check the output ripple amplitude. The maximum ripple voltage is given in Table 5-3.

NOTE

Ground loops can cause erroneous ripple measurement. (Ripple due to ground loops is the same frequency as the line; Low voltage power supply ripple is twice the line rate.) One way to avoid

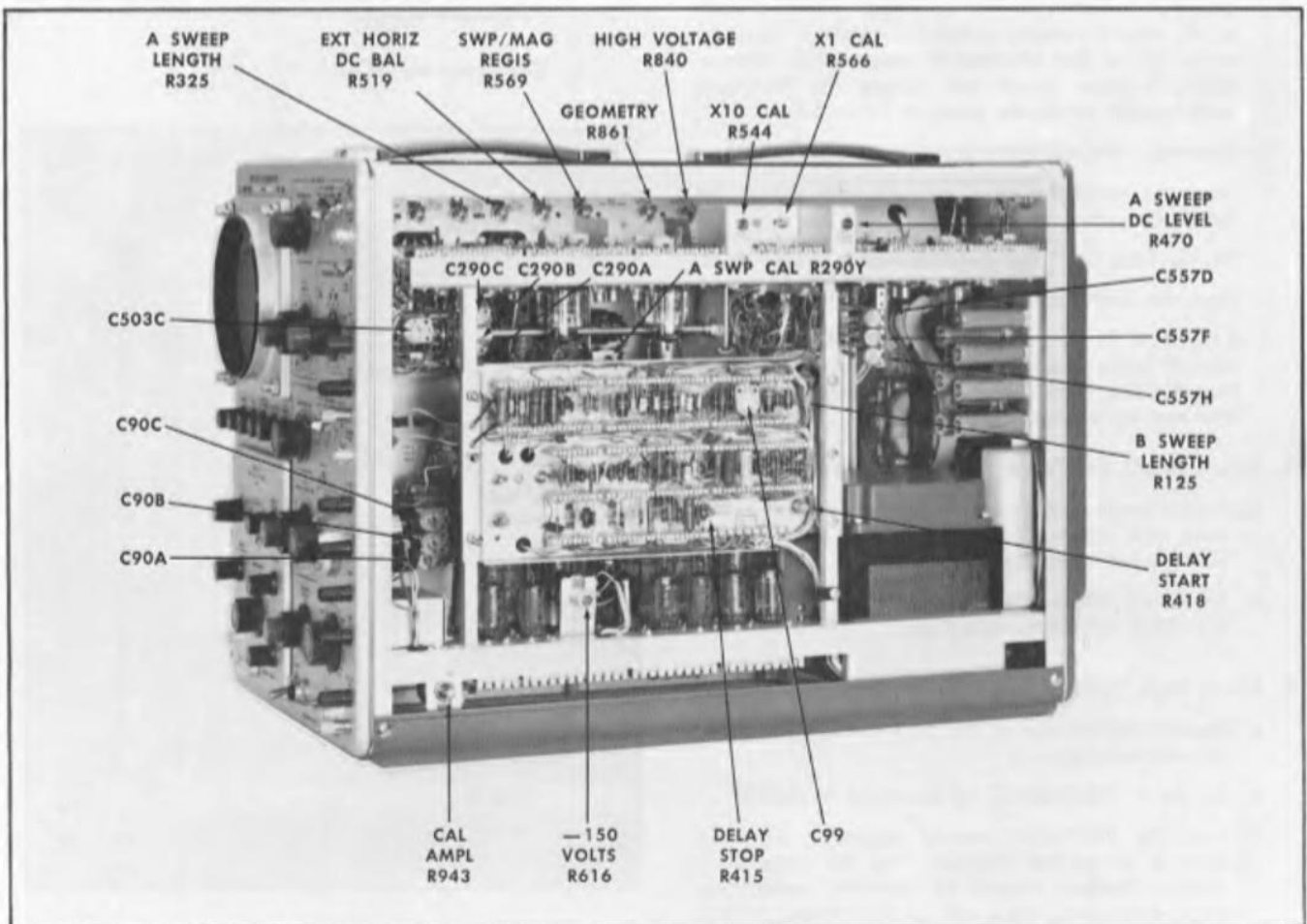

Fig. 5-2. Calibration adjustment locations.

ripple due to ground loops is to temporarily disconnect the chassis ground wire in the power cord by using an ungrounded 3- to 2-wire line-plug adapter. Then use a ground lead from the signal probe body to make a ground connection to the oscilloscope chassis at the location shown in Fig. 5-1. The probe will then provide the only ground connection between the two instruments. The term "test oscilloscope" is item 1 under "Equipment Required" while the term "oscilloscope" or "instrument" is the oscilloscope being calibrated.

- c. Slowly increase the output of the variable autotransformer to 126.5 vac (or 10% above the design-center line voltage for which the instrument is wired). The dc output voltage should remain essentially constant; typically within 2% of that obtained with design-center line voltage. The ripple voltage should not exceed the maximum peak-to-peak amplitude given in Table 5-3.
- d. Repeat steps 2a through 2c for each supply.
- e. Reset the autotransformer for 115 volts output (or the design-center voltage for which the instrument is wired).
- f. Set the Type TU-7 Test Function switch to High Load.
- g. Reduce the line voltage to 103.5 volts (or 10% below design-center voltage). The dc output voltage of each supply should remain essentially constant; typically within 2% of that obtained at design-center voltage. Ripple voltage should not exceed the maximum peak-to-peak amplitude given in Table 5-3.
- h. Disconnect the voltohmmeter and X1 probe.
- i. Reset the autotransformer for 115 volts output (or the design-center voltage).
- j. Set the Type TU-7 Test Function switch to Low Load.
- k. Place the instrument in its upright position.
- l. If the 3- to 2-wire adapter was used during this step, turn off oscilloscope power and remove the adapter. Plug the line cord directly into the autotransformer and turn on the oscilloscope power.

3. Adjust HIGH VOLTAGE R840—Crt Circuit

- a. Set the range of the voltohmmeter to measure -1850 volts and connect the voltohmmeter to the high-voltage test point (see Fig. 5-3).
- b. Adjust the HIGH VOLTAGE R840 (see Fig. 5-2) for a -1850 voltmeter indication.

4. Check High Voltage Regulation—Crt Circuit

- a. Monitor the voltage at the high voltage test point with the voltohmmeter.
- b. Set the A TRIGGERING MODE switch to AUTO.
- c. Turn the INTENSITY control clockwise until the trace is at normal intensity. Use the Type TU-7 Vertical Position control to vertically center the trace. Defocus the trace with the FOCUS and ASTIGMATISM controls. Set the INTENSITY control at 7.

- d. Use the HORIZONTAL POSITION control to position the trace to start at the left side of the graticule.
- e. Slowly increase the output of the variable autotransformer to 126.5 vac (or 10% above the design-center line voltage for which the instrument is wired). The high-voltage dc output should remain essentially constant; typically within 2% of that obtained with design-center line voltage. The trace should not show any signs of blooming. (Blooming is when the display changes size as the supply voltage changes.)
- f. Reset the autotransformer for 115 volts output (or design-center voltage).
- g. Set the Type TU-7 Test Function switch to High Load.
- h. Reduce the line voltage to 103.5 volts (or 10% below design-center voltage). The dc output voltage should remain constant; typically within 2% of that obtained with design-center line voltage. The trace should not show any signs of blooming.
- i. Reset the autotransformer for 115 volts output (or the design-center voltage).
- j. Set the Type TU-7 Test Function switch to Low Load.
- k. Decrease the trace intensity to normal with the INTENSITY control.
- l. Disconnect the VOM.

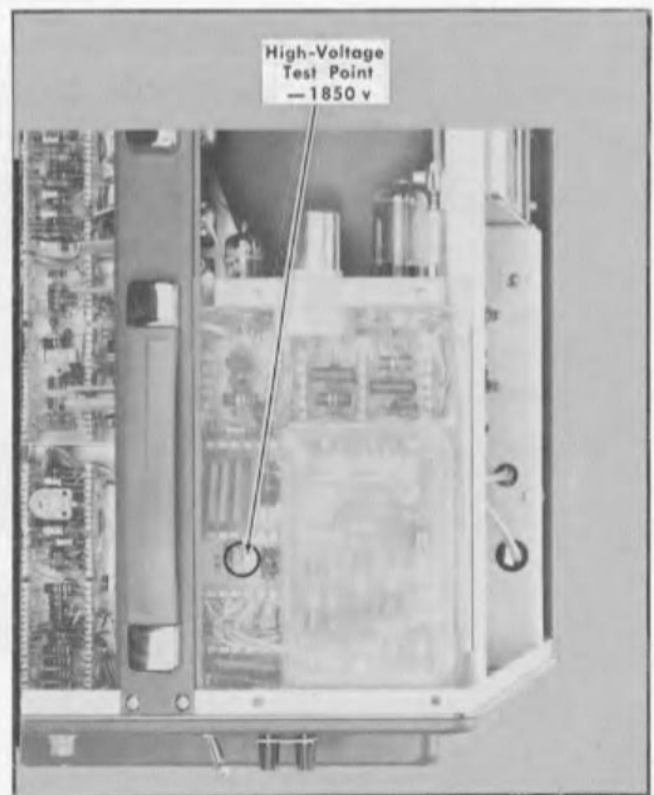

Fig. 5-3. High-voltage test point location.

5. Adjust CAL AMPL (Calibrator Amplitude) R943—Calibrator

- a. Connect the single binding post adapter to the oscilloscope CAL OUT connector.
- b. Connect the VOM to the binding post adapter and to the oscilloscope chassis.
- c. Set the AMPLITUDE CALIBRATOR switch to 100 V DC.
- d. Adjust CAL AMPL R943 (see Fig. 5-2) for a voltmeter reading of exactly 100 volts.

6. Check Duty Factor of Signal—Calibrator

- a. Set the AMPLITUDE CALIBRATOR switch to 100 VOLTS (not 100 V DC).
- b. Check for +45 to +55 volts measured between the CAL OUT connector and ground.

NOTE

+50 volts indicates a nominal duty factor of 0.5. If the voltage is not within +45 to +55 volts, try new tubes.

- c. Disconnect the VOM and set the AMPLITUDE CALIBRATOR switch to OFF.
- d. Remove the adapter from the CAL OUT connector.

7. Adjust TRACE ROTATION—Crt Circuit

- a. Adjust the FOCUS and ASTIGMATISM controls for the narrowest trace.
- b. Position the trace directly behind the center horizontal graticule line, using the Type TU-7 Vertical Position control.
- c. If the trace and graticule line do not coincide over the width of the graticule, adjust the TRACE ROTATION control for correct trace alignment.

8. Adjust GEOMETRY R861—Crt Circuit

- a. Apply 50- μ sec markers from the time-mark generator through a coaxial cable to the Type TU-7 Ext Input connector.
- b. Set the A TIME/CM switch to 50 μ SEC.
- c. Advance the INTENSITY control to make the display visible.
- d. Set the TRIGGERING LEVEL control to obtain a stable display of vertical marker lines.
- e. Adjust the TU-7 Variable control so the markers over-scan the crt; set the Vertical Position control to position the base line of the markers below the display area.
- f. Use the HORIZONTAL POSITION control to position the markers so they align with the graticule markings.
- g. Adjust GEOMETRY R861 (see Fig. 5-2) for the straightest possible vertical marker-lines running parallel to

the 0 and 10-cm graticule lines at the left and right edges of the graticule. Note the amount of bowing.

- h. Disconnect the signal from the TU-7 Ext Input connector.
- i. Reduce the trace intensity to normal with the INTENSITY control while positioning the trace onto the crt with the TU-7 Vertical Position control.
- j. Position the trace to the bottom of the graticule with the TU-7 Vertical Position control. Note the amount of bowing. Then position the trace to the top of the graticule and note the amount of bowing.
- k. Repeat steps 8a through 8j so the trace exhibits minimum bowing in both planes.
- l. After completing the previous steps, disconnect the signal from the TU-7 Ext Input connector. Check that the trace is positioned into the display area and the INTENSITY control is set to a suitable trace-brightness level.

9. Adjust VERT DC BAL (Vertical Amplifier Dc Balance) R1004—Vertical Amplifier

- a. Using a small screwdriver, short the crt vertical deflection-plate pins together (see Fig. 5-4).

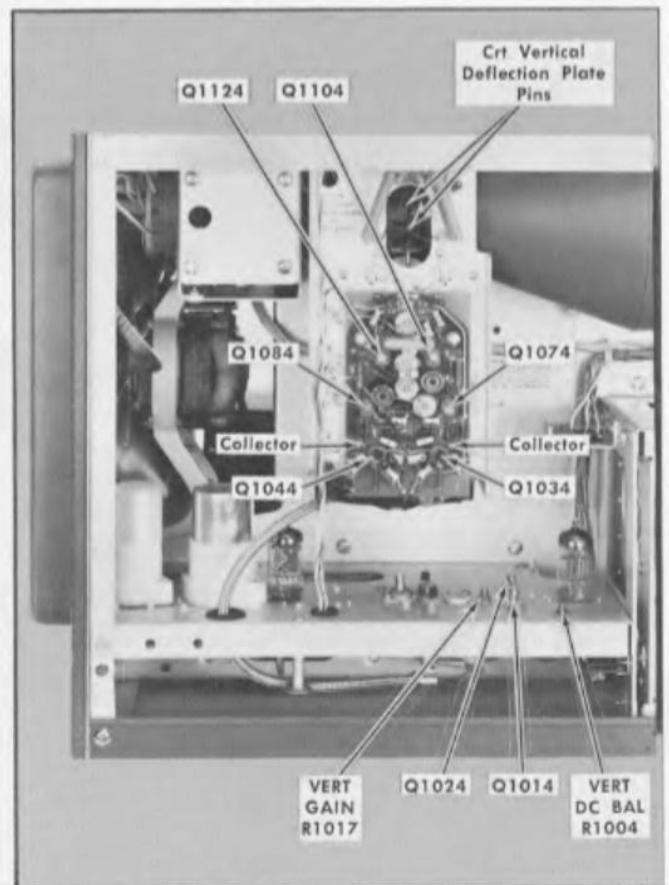

Fig. 5-4. Vertical Amplifier test points and adjustment locations for performing steps 9 and 10.

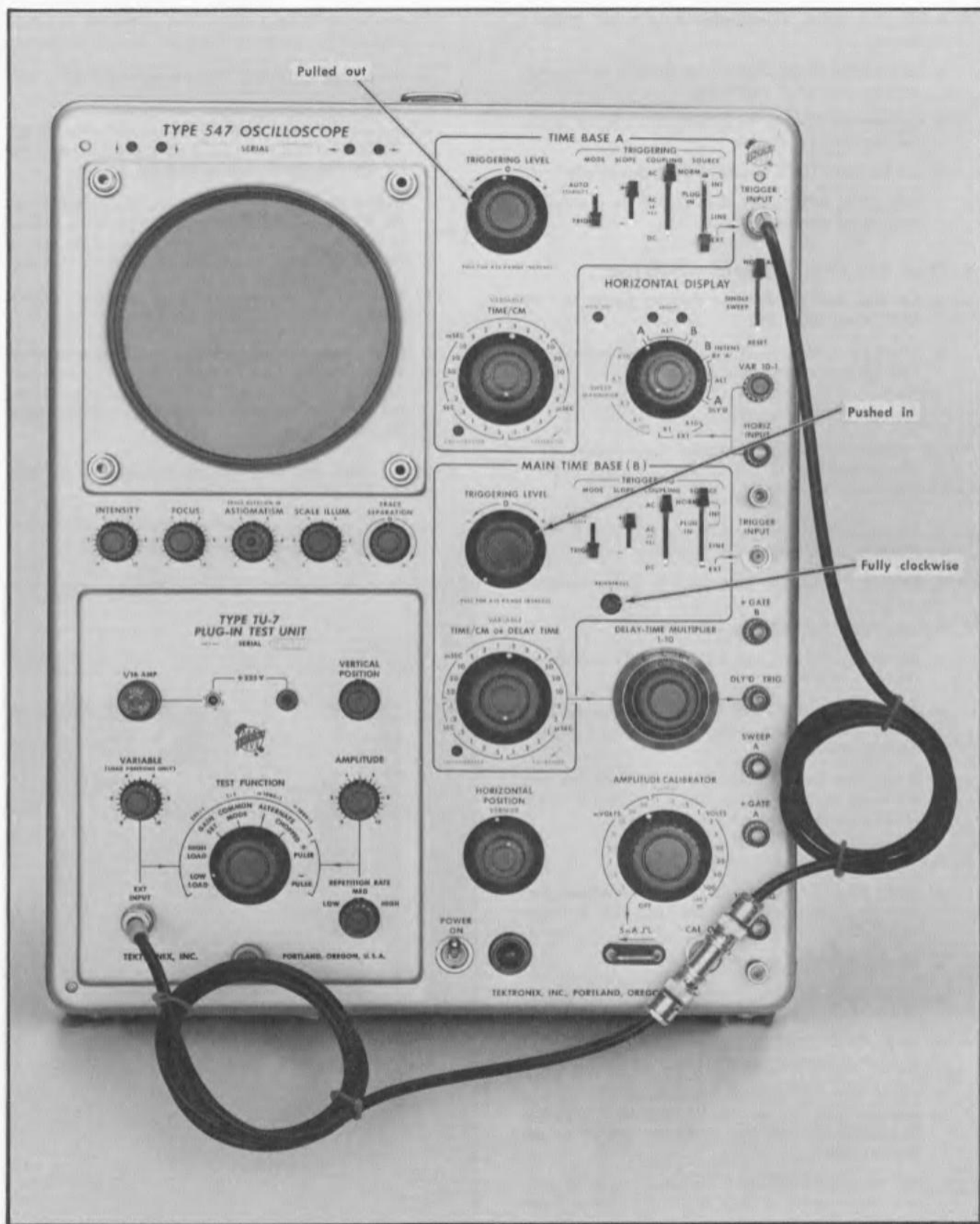

Fig. 5-5. Front-panel control settings and signal connections at the completion of step 12e.

CAUTION

Do not short the crt deflection-plate pins to ground.

- b. Note the position of the trace. This is the electrical center of the crt vertical deflection plates.
- c. Remove the screwdriver from the crt pins.
- d. Short the cases of Q1074 and Q1084 (see Fig. 5-4) together (not to ground) and note the trace deviation from electrical center. Deviation should not be more than 0.5 cm maximum. Remove the short.
- e. Short the collector of Q1034 to the collector of Q1044 (see Fig. 5-4) and note the trace deviation from electrical center. Deviation should not be more than 0.5 cm maximum. Remove the short.
- f. Short the cases of Q1014 and Q1024 (see Fig. 5-4) together (not to ground) and note the trace deviation from electrical center. Deviation should not be more than 0.5 cm maximum. Remove the short.
- g. Set the Type TU-7 Test Function switch to Common Mode.
- h. Adjust VERT DC BAL R1004 (see Fig. 5-4) to position the trace to the center of the graticule.

10. Adjust VERT GAIN (Vertical Amplifier Gain) R1017 Vertical Amplifier

- a. Set the Type TU-7 Test Function switch to the Gain Set position.
- b. Connect a coaxial cable between the Type TU-7 Ext Input connector and the oscilloscope CAL OUT connector.
- c. Set the AMPLITUDE CALIBRATOR switch to 100 VOLTS.
- d. Pull the A TRIGGERING LEVEL control outward for a X10 range increase and turn the control fully clockwise to free run the time base.
- e. Adjust VERT GAIN R1017 (see Fig. 5-4) so the display vertical deflection is exactly 4 cm in amplitude.

11. Check Common-Mode Rejection—Vertical Amplifier

- a. Set the AMPLITUDE CALIBRATOR switch to 1 VOLT.
- b. Set the TU-7 Test Function Switch to Common Mode.
- c. Set the A TIME/CM switch to .5 mSEC.
- d. Note the amplitude of the calibrator waveform. The amplitude of the waveform should not be more than 3 mm maximum.

12A. Adjust A TRIGGER LEVEL CENTERING R225 and A TRIGGER SENS R245—A Sweep Trigger (SN 6740-up)

- a. Set the AMPLITUDE CALIBRATOR to .1 volts.

NOTE

A 100 mv peak-to-peak signal is used in this portion of the procedure as an adjustment aid only and is not intended to be interpreted as a trigger-amplitude specification that contradicts the one given in the Characteristics section of this manual.

- b. Insert a BNC T connector between the CAL OUT connector and the coax cable to the TU-7 Ext Input. Connect another coax cable from the T connector to the A TRIGGER INPUT connector. (The CAL OUT connector should now be connected to the Ext Input connector on the TU-7 and to the A TRIGGER INPUT connector on the oscilloscope.)
- c. Set the front-panel controls as follows:

Type 547/RM547

Controls not mentioned may be left as is.

INTENSITY	As required for a visible trace
FOCUS	As required for a focused trace
ASTIGMATISM	As required for a focused trace
SCALE ILLUM	As required for a visible graticule
HORIZONTAL POSITION	As required to position trace to the left edge of the graticule
VERNIER (HORIZONTAL POSITION)	Midrange
HORIZONTAL DISPLAY	A
SWEEP MAGNIFIER	X1 (OFF)
SINGLE SWEEP Switch	Normal

Time Base A

TRIGGERING LEVEL	0
TIME/CM	.5 mSEC
TRIGGERING MODE	TRIG
SLOPE	+
COUPLING	AC
SOURCE	EXT

TU-7

Variable	Fully Clockwise
Vertical Position	Centered
Test Function	Low Load

Test Oscilloscope

Input Coupling	AC
Volts/Div	.02
Time/Div	.5 mSEC

Calibration—Type 547/RM547

Triggering

Mode	AUTO
Slope	+
Coupling	AC
Source	Internal

- Locate the junction of R217, C218, R218, (See Fig. 5-6a). Connect a short jumper clip lead between the junction and ground. This jumper disables the A TRIGGERING LEVEL control.
- Locate the junction of R252 and L250 (See Fig. 5-6a). Connect a 10 \times probe from the test oscilloscope to this junction.
- Preset the A TRIGGER LEVEL CENTERING R225 control to midrange and the A TRIG SENS R245 control fully clockwise.
- Adjust the A TRIGGER LEVEL CENTERING R225 control for a stable square wave display of approximately 200 mv peak-to-peak. Note that there is a range in the adjustment of R225 through which the square wave display will remain stable. Set R225 approximately in the middle of this range.
- Change the SLOPE switch to — and readjust R225 if necessary. Continue alternating the position of the SLOPE switch and adjusting R225 until the square wave on the test scope is stable in both positions of the SLOPE switch.
- Turn the A TRIGGER SENS R245 control counter-clockwise until the square wave on the test oscilloscope just begins to break up. (This will occur where the square wave suddenly reduces in amplitude.) Leave R245 set at this point.
- Readjust the A TRIGGER LEVEL CENTERING R225 control for a stable square wave display at both positions of the SLOPE switch. [Note that there is a range in the adjustment of R225 over which a stable square wave can be obtained. Set R225 in the center of this range.]
- Set the AMPLITUDE CALIBRATOR switch to 50 mVOLTS. The amplitude of the square wave display on the test oscilloscope should be reduced to less than 100 millivolts in either position of the SLOPE switch. If the amplitude of the square wave on the test oscilloscope remains at approximately 200 millivolts, repeat i through k.
- Disconnect the 10 \times probe from the junction of R252 and L250.

12B. Adjust A TRIGGER LEVEL CENTERING R225 and A TRIGGER SENS R245—A Sweep Trigger (SN 101-6739)

- Set the AMPLITUDE CALIBRATOR switch to 50 mvolts.
- Insert the BNC T connector between the AMPLITUDE CALIBRATOR connector and the coaxial cable.

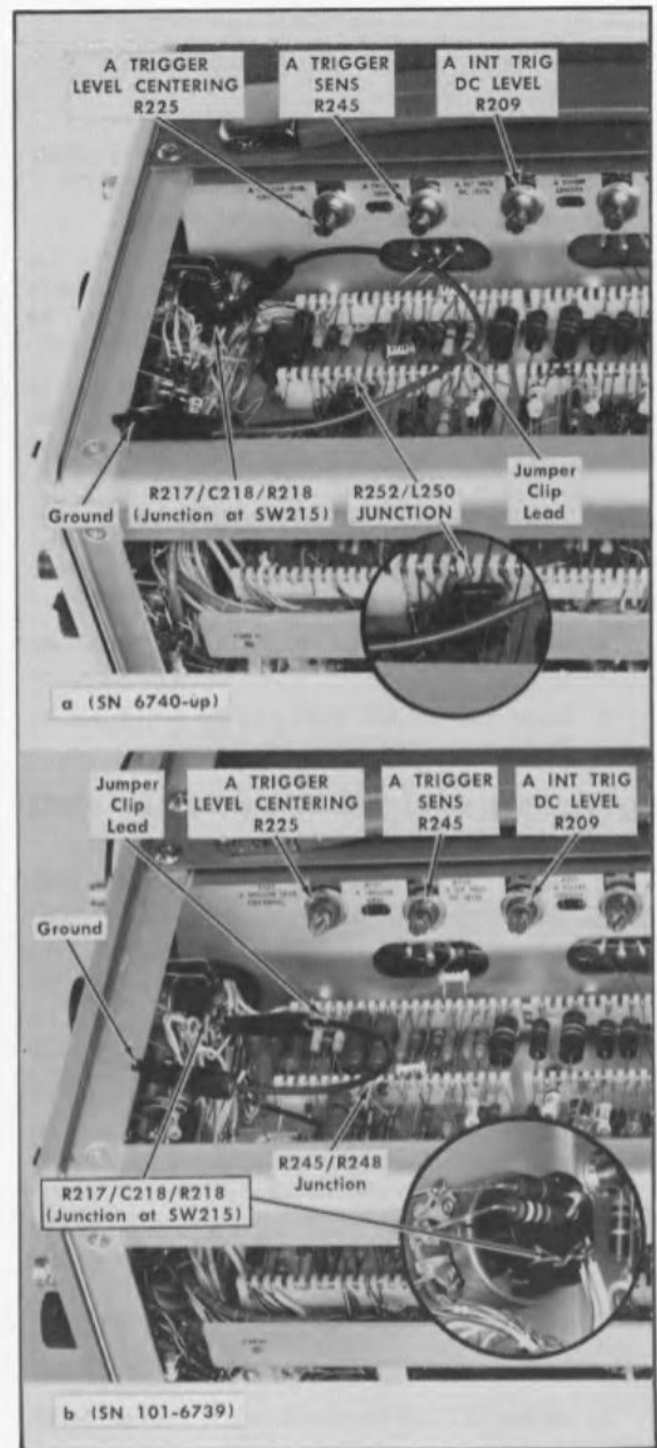

Fig. 5-6. A Trigger clip-lead connections, adjustment and test point locations.

- Connect another coaxial cable from the T connector to the A TRIGGER INPUT connector. (The CAL OUT connector should now be connected to the Ext Input connector on the Type TU-7 and to the A TRIGGER INPUT connector on the oscilloscope.)

- d. Set the TU-7 front-panel controls as follows:

Variable	Fully clockwise
Vertical Position	Centered
Test Function	Low Load

- e. Set the A MODE switch to TRIG and the A TRIGGERING LEVEL control to 0. Check that the A COUPLING switch is set at AC and the A SOURCE switch is set to EXT.
- f. Locate the junction of R217, C218, and R218. Connect the short jumper clip lead between the junction and ground. This jumper disables the A TRIGGERING LEVEL control.
- g. Connect a 10× Probe from the test oscilloscope to the junction of R245-R248.
- h. Set the test oscilloscope controls as follows:

INPUT COUPLING	AC
VOLTS/DIV	.02
TIME/DIV	.2 mSEC

TRIGGERING	
MODE	AUTOMATIC
SLOPE	+
COUPLING	AC
SOURCE	INTERNAL

- i. Set the TRIGGER SENS R245 to midrange.
- j. Rotate TRIGGER LEVEL CENTERING R225 fully counterclockwise.
- k. Rotate TRIGGER LEVEL CENTERING R225 clockwise until a stable display 2 to 3 major divisions high appears on the test oscilloscope.
- l. If no stable display appears on the test oscilloscope, rotate the TRIGGER SENS R245 slightly clockwise, then repeat part k.
- m. Change the Triggering SLOPE switch to — and check for a stable display on the test oscilloscope. If necessary readjust the TRIGGER LEVEL CENTERING R225 slightly so as to obtain a stable test oscilloscope in both positions of the A SLOPE switch.
- n. If a stable test oscilloscope display can not be obtained for both A SLOPE switch positions, rotate the TRIGGER SENS R245 slightly clockwise and repeat part m.
- o. After obtaining a stable test oscilloscope display for both A SLOPE switch positions, rotate the TRIGGER SENS R245 slightly counterclockwise. Again check for a stable test oscilloscope display in both positions of A SLOPE switch. TRIGGER LEVEL CENTERING R225 may have to be readjusted slightly.
- p. Continue rotating the TRIGGER SENS R245 slightly counterclockwise and then checking the test oscilloscope display until a stable test oscilloscope display can not be obtained for both positions of the Triggering SLOPE switch.
- q. Rotate the TRIGGER SENS R245 just enough clockwise to permit a stable test oscilloscope display to

be obtained for both positions of the Triggering SLOPE switch. Slight readjustment of TRIGGER LEVEL CENTERING R225 will probably be necessary.

13. Adjust A INT TRIG DC LEVEL R209—A Sweep Trigger

- Set the AMPLITUDE CALIBRATOR switch to .5 VOLTS.
- Set the A SOURCE switch to NORM INT.
- Adjust the TU-7 Variable control so the displayed waveform is 5 mm peak-to-peak in amplitude.
- Using the TU-7 Vertical Position control, center the display for equal amplitude above and below the graticule centerline.
- Set the A COUPLING switch to DC.
- Adjust A INT TRIG DC LEVEL R209 (see Fig. 5-6) to obtain a stable display. (With the A SLOPE switch set to +, the sweep trace should start on the positive-going rise of the calibrator waveform.)

14. Check Internal Triggering—A Sweep Trigger

- Set the A COUPLING switch to AC.
- Adjust the TU-7 Variable control until the display is 2 mm peak-to-peak in amplitude.
- Disconnect the jumper clip lead.
- Adjust the A TRIGGERING LEVEL control to obtain a stable display.
- Check for stable time-base triggering on the — slope when the A SLOPE switch is set to — and on the + slope when the SLOPE switch is set to +. If necessary, readjust the A TRIGGERING LEVEL control to obtain a stable display when checking each SLOPE switch position.

15. Check A TRIGGERING LEVEL Control Zero Set—A Sweep Trigger

- Check that the A TRIGGERING LEVEL control is set to 0 and the A SLOPE switch is set to +.
- Connect the VOM between the R217/C218/R218 junction and ground.
- Carefully turn the A TRIGGERING LEVEL control to obtain a reading of ± 0.1 V on the VOM.
- If the A TRIGGERING LEVEL knob is set properly on the control shaft, the white dot on the knob should be directly below the 0 on the front panel. If the white dot does not point exactly to 0, disconnect the VOM, loosen the setscrew in the knob and reposition the knob.
- After tightening the knob, set the knob to 0, reconnect the VOM, and recheck the reading. The VOM reading should be within ± 0.1 V of zero when the A TRIGGERING LEVEL knob is set to 0.

Calibration—Type 547/RM547

NOTE

A dc-coupled test oscilloscope with a $\times 10$ probe can be used in place of the VOM to perform step 15.

As another method, the TRIGGERING LEVEL knob can be checked for correct position by repeating step 14e. This method does not require the use of a test oscilloscope or VOM. When performing step 14e the TRIGGERING LEVEL knob should point to 0 when stable triggering is obtained.

f. Disconnect the VOM or $\times 10$ probe, whichever is used.

16A. Adjust B TRIGGER LEVEL CENTERING R25 and B TRIGGER SENS R45—B Sweep Trigger (SN 6740-up)

a. Set the AMPLITUDE CALIBRATOR to .1 volts.

NOTE

A 100 mv peak-to-peak signal is used in this portion of the procedure as an adjustment aid only and is not intended to be interpreted as a trigger-amplitude specification that contradicts the one given in the Characteristics section of this manual.

b. Insert a BNC T connector between the CAL OUT connector and the coax cable to the TU-7 Ext Input. Connect another coax cable from the T connector to the B TRIGGER INPUT connector. (The CAL OUT connector should now be connected to the Ext Input connector on the TU-7 and to the B TRIGGER INPUT connector on the oscilloscope.)

c. Set the front panel controls as follows:

Type 547/RM547

Controls not mentioned may be left as is

HORIZONTAL DISPLAY	B
BRIGHTNESS	As required for visible trace

Time Base B

TRIGGERING LEVEL	0
TIME/CM	.5 mSEC
TRIGGERING	
MODE	TRIG
SLOPE	+
COUPLING	AC
SOURCE	EXT

TU-7

Variable	Fully Clockwise
Vertical Position	Centered
Test Function	Low Load

Test Oscilloscope

Input Coupling	AC
Volts/Div	.02
Time/Div	.5 mSEC
Triggering	
Mode	AUTO
Slope	+
Coupling	AC
Source	Internal

- Locate the junction of R17, C18, R18 (See Fig. 5-7a). Connect a short jumper clip lead between the junction and ground. This jumper disables the B TRIGGERING LEVEL control.
- Locate the junction of R52 and L50 (See Fig. 5-7a). Connect a $10\times$ probe from the test oscilloscope to this junction.
- Preset the B TRIGGER LEVEL CENTERING R25 control to midrange and the B TRIG SENS R45 fully clockwise.
- Adjust the B TRIGGER LEVEL CENTERING R25 control for a stable display of square waves on the test oscilloscope. (The square waves will have an amplitude of approximately 200 mv peak-to-peak.) Note that there is a range in the adjustment of R25 through which the square wave will remain stable. Set R25 approximately in the middle of this range.
- Change the SLOPE switch to — and readjust R25 if necessary. Continue alternating the position of the SLOPE switch and adjusting R25 until the square wave display on the test oscilloscope is stable in both positions of the SLOPE switch.
- Turn the B TRIGGER SENS R45 control counterclockwise until the square wave display on the test oscilloscope just begins to break up. (This will occur where the square wave suddenly reduces in amplitude.) Leave R45 set at this point.
- Readjust the B TRIGGER LEVEL CENTERING R25 control for a stable square wave display at both positions of the SLOPE switch. (Note that there is a range in the adjustment of the R25 over which a stable square wave can be obtained. Set R25 in the center of this range.)
- Set the AMPLITUDE CALIBRATOR to 50 mVOLTS. The amplitude of the square wave display on the test oscilloscope should be reduced to less than 100 millivolts in either position of the SLOPE switch. If the amplitude of the square wave display on the test oscilloscope remains at approximately 200 millivolts, repeat steps i through k.
- Disconnect the $10\times$ probe from the junction of R52 and L50.

16B. Adjust B TRIGGER LEVEL CENTERING R25 and B TRIGGER SENS R45—B Sweep Trigger (SN 101-6739)

a. Set the AMPLITUDE CALIBRATOR switch to 50 mvolts.

- b. Insert the BNC T connector between the AMPLITUDE CALIBRATOR connector and the coaxial cable.
- c. Connect another coaxial cable from the T connector to the B TRIGGER INPUT connector. (The CAL OUT connector should now be connected to the Ext Input connector on the Type TU-7 and to the B TRIGGER INPUT connector on the oscilloscope.)

d. Set the TU-7 front-panel controls as follows:

VARIABLE	Fully clockwise
POSITION	Centered
TEST FUNCTION	Low Load

e. Set the B MODE switch to TRIG and the B TRIGGERING LEVEL control to 0. Check that the B COUPLING switch is set at AC and the B SOURCE switch is set to EXT.

f. Locate the junction of R17, C18, and R18. Connect the short jumper clip lead between the junction and ground. This jumper disables into A TRIGGERING LEVEL control.

g. Connect a 10X Probe from the test oscilloscope the junction of R45-R48.

h. Set the test oscilloscope controls as follows:

INPUT COUPLING	AC
VOLTS/DIV	.02
TIME/DIV	.2 mSEC

TRIGGERING

MODE	AUTOMATIC
SLOPE	+
COUPLING	AC
SOURCE	INTERNAL

i. Set the TRIGGER SENS R45 to midrange.

j. Rotate TRIGGER LEVEL CENTERING R25 fully counterclockwise.

k. Rotate TRIGGER LEVEL CENTERING R25 clockwise until a stable display 2 to 3 major divisions high appears on the test oscilloscope.

l. If no stable display appears on the test oscilloscope, rotate the TRIGGER SENS R45 slightly clockwise, then repeat part k.

m. Change the Triggering SLOPE switch to — and check for a stable display on the test oscilloscope. If necessary readjust the TRIGGER LEVEL CENTERING R25 slightly so as to obtain a stable test oscilloscope in both positions of the A SLOPE switch.

n. If a stable test oscilloscope display can not be obtained for both B SLOPE switch positions, rotate the TRIGGER SENS R45 slightly clockwise and repeat part m.

o. After obtaining a stable test oscilloscope display for both B SLOPE switch positions, rotate the TRIGGER SENS R45 slightly counterclockwise. Again check for a stable test oscilloscope display in both positions of B SLOPE switch. TRIGGER LEVEL CENTERING R25 may have to be readjusted slightly.

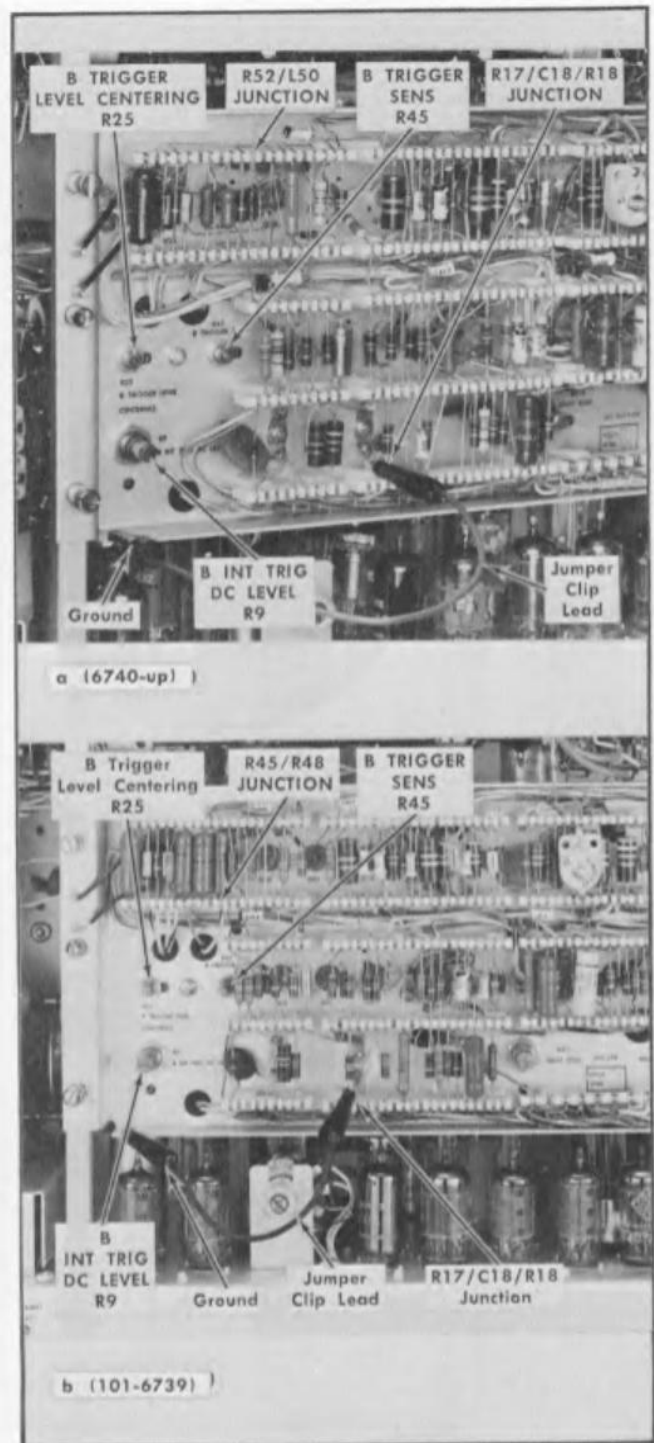

Fig. 5-7. B Trigger clip-lead connections, adjustment and test point locations.

p. Continue rotating the TRIGGER SENS R45 slightly counterclockwise and then checking the test oscilloscope display until a stable test oscilloscope display can not be obtained for both positions of the Triggering SLOPE switch.

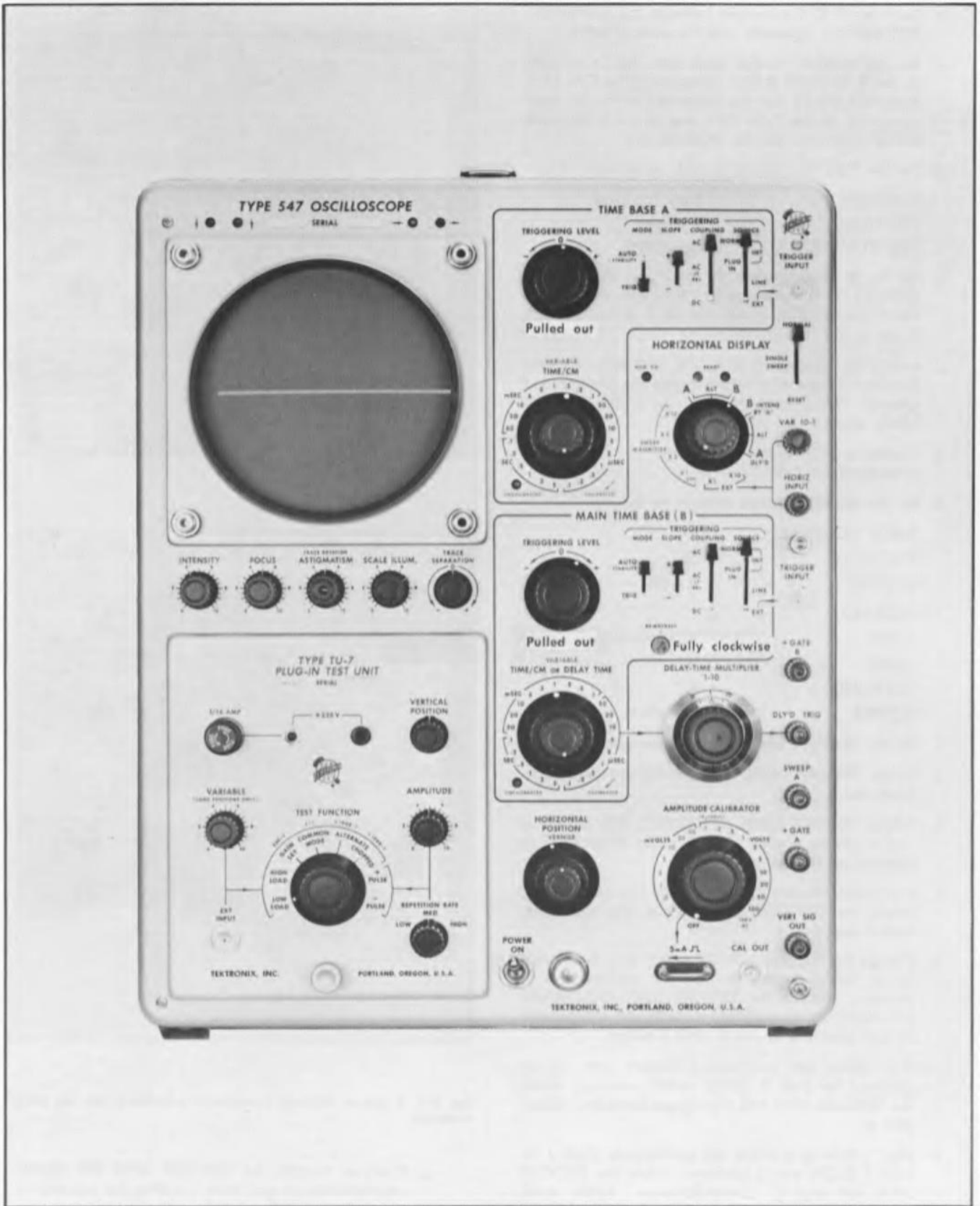

Fig. 5-8. Front-panel control settings at the completion of step 20a.

- q. Rotate the TRIGGER SENS R45 just enough clockwise to permit a stable test oscilloscope display to be obtained for both positions of the Triggering SLOPE switch. Slight readjustment of TRIGGER LEVEL CENTERING R25 will probably be necessary.

17. Adjust B INT TRIG DC LEVEL R9 — B Sweep Trigger

- a. Set the AMPLITUDE CALIBRATOR switch to .5 VOLTS.
- b. Set the B SOURCE switch to NORM INT.
- c. Adjust the TU-7 Variable control so the displayed waveform is 5 mm peak-to-peak in amplitude.
- d. Using the TU-7 Vertical Position control, center the display for equal amplitude above and below the graticule centerline.
- e. Set the B COUPLING switch to DC.
- f. Adjust B INT TRIG DC LEVEL R9 (see Fig. 5-7) to obtain a stable display. (With the B SLOPE switch set to +, the sweep trace should start on the positive-going rise of the calibrator waveform.)

18. Check Internal Triggering — B Sweep Trigger

- a. Set the B COUPLING switch to AC.
- b. Adjust the TU-7 Variable control until the display is 2 mm peak-to-peak in amplitude.
- c. Disconnect the jumper clip lead.
- d. Adjust the B TRIGGERING LEVEL control to obtain a stable display.
- e. Check for stable time-base triggering on the — slope when the B SLOPE switch is set to — and on the + slope when the SLOPE switch is set to +. If necessary, readjust the B TRIGGERING LEVEL control to obtain a stable display when making the check for each SLOPE switch position.

19. Check B TRIGGERING LEVEL Control Zero Set -- B Sweep Trigger

- a. Check that the B TRIGGERING LEVEL control is set to 0 and the SLOPE switch is set to +.
- b. Connect the VOM between the R17/C18/R18 junction and ground.
- c. Carefully adjust the B TRIGGERING LEVEL control to obtain a reading of exactly zero volts on the VOM.
- d. If the B TRIGGERING LEVEL knob is set properly on the control shaft, the white dot on the knob should be directly below the 0 on the front panel. If the white dot does not point exactly to 0, disconnect the VOM, loosen the setscrew in the knob, and reposition the knob.
- e. After tightening the knob, set the knob to 0, reconnect the VOM, and repeat steps (c) and (d).

NOTE

A dc-coupled test oscilloscope with a X10 probe can be used in place of the VOM to perform this step, if desired.

As another method, the TRIGGERING LEVEL knob can be checked for correct position by repeating step 18e. This method does not require the use of a test oscilloscope or VOM. When performing step 18e, the TRIGGERING LEVEL knob should point to 0 when stable triggering is obtained.

- f. Disconnect the VOM or X10 probe, whichever is used.
- g. Disconnect the coaxial cables, T connector, and set the AMPLITUDE CALIBRATOR switch to OFF.

20. Adjust SWP/MAG REGIS R569 — Horizontal Amplifier

- a. Set the Main Time Base (B) front-panel controls to these settings:

TRIGGERING LEVEL	About 25° clockwise from 0.
MODE	AUTO
SLOPE	+
COUPLING	AC
SOURCE	NORM INT
TIME/CM	1 mSEC

All front-panel control settings up to this point in the procedure are shown in Fig. 5-8.

- b. Apply 100- μ sec, 1-msec, and 5-msec time markers from the time-mark generator through a coaxial cable to the TU-7 Ext Input connector.
- c. Set the TU-7 Variable control so the display is about 4 cm in amplitude.
- d. Center the display vertically using the TU-7 Vertical Position control.
- e. Adjust, if necessary, the B TRIGGERING LEVEL control to obtain stable triggering on the 5-msec time marks. Fig. 5-9a shows the time markers displayed with respect to the graticule markings. Use the HORIZONTAL POSITION control to position the center 5-msec time marker to the center of the graticule as shown in the illustration.
- f. Set the SWEEP MAGNIFIER switch to X10. Position the 5-msec time marker to graticule center (see Fig. 5-9b) and then set the SWEEP MAGNIFIER switch to X1 OFF.
- g. Adjust SWP/MAG REGIS R569 (see Fig. 5-2) to position the center 5-msec time marker to graticule center. If necessary, repeat steps 20f and 20g until there is no movement of the 5-msec time marker as the SWEEP MAGNIFIER switch is changed from X10 to X1 OFF.

21. Adjust X10 CAL R544 — Horizontal Amplifier

- a. Set the SWEEP MAGNIFIER switch to X10.
- b. Adjust X10 CAL R544 (see Fig. 5-2) so there is 1 marker/cm from the 1-cm to 9-cm graticule lines. For accurate adjustment, set X10 CAL R544 so the 2nd and 10th markers at the 1-cm and 9-cm graticule

Calibration—Type 547/RM547

lines respectively coincide exactly with the 1-cm and 9-cm graticule lines.

NOTE

The following hints should help you to obtain the best results when checking and adjusting the time-base sweep rates:

It is quite difficult to detect small sweep-rate errors on the order of 1% or 2% unless measuring over most of the graticule width. It is therefore recommended that the sweep rates be checked for correct linearity and timing using the center 8 cm and the middle 80% of the display as shown in Fig. 5-10. Measuring over a distance of 8 cm, the adjustment can be made more accurately. Later in the procedure when checking the nonadjustable sweep rates without using the DELAY-TIME MULTIPLIER control, a 1.6-mm error would indicate a 2% sweep-rate error as shown in Fig. 5-11. The marker peak provides an excellent reference point particularly if the amplitude is such that the base line is below the crt viewing area and the tips of the markers are located in the center of the crt. When using the sine waves for markers at the higher sweep rates, set the TU-7 Variable and Vertical Position controls so the lower half of the display is positioned below the crt and the tips of each cycle are near the center of the crt. By increasing the amplitude of the display in this manner each marker or cycle tip appears much narrower.

The adjustable sweep rates should be set for maximum accuracy. When adjusting the timing capacitors, use a screwdriver having a metal tip and a nonmetallic shank to minimize capacitive disturbances to the circuit. This will also lessen the chance of accidentally grounding connections elevated above or below ground.

22. Adjust X1 CAL R566 — Horizontal Amplifier

- Set the SWEEP MAGNIFIER switch to X1 OFF.
- Adjust X1 CAL R566 (see Fig. 5-2) so the 1-msec markers are spaced 1-cm apart and the 1-msec markers at the 1-cm and 9-cm points coincide with the graticule lines.
- Due to some interaction between the X10 CAL and X1 CAL adjustments, repeat steps 21 and 22 until the timing is correct.

23. Check MAG ON Neon — Horizontal Amplifier

- Check that the MAG ON neon lights when the SWEEP MAGNIFIER switch is set to each one of these positions: X2, X5, and X10.
- Set the SWEEP MAGNIFIER switch to X1 OFF.

24. Adjust B SWEEP LENGTH R125 — B Sweep Generator

- Check that the display is positioned to start at the left side of the graticule or 0-cm line.

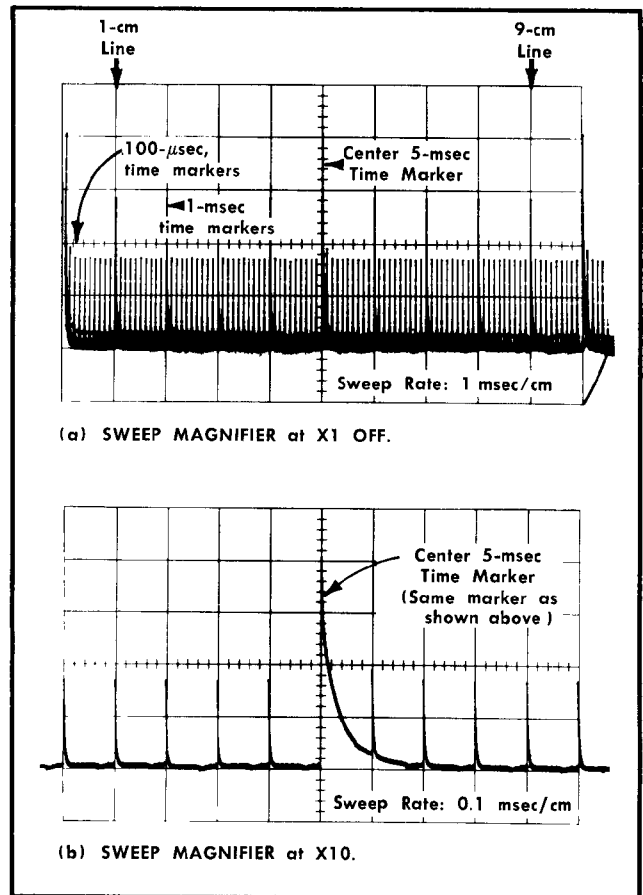

Fig. 5-9. Time-marker displays.

- Adjust B SWEEP LENGTH R125 (see Fig. 5-2) for sweep length of 10.5 cm. When the adjustment is made correctly, there will be five 100-μsec time marks after the 5-msec time mark located at the 10-cm graticule line.

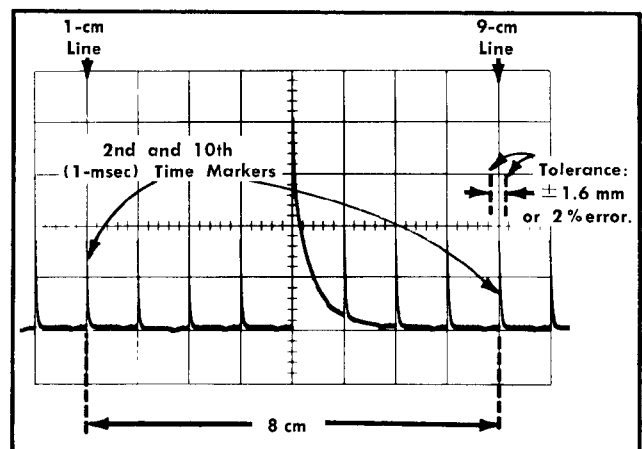

Fig. 5-10. Determining sweep-rate accuracy.

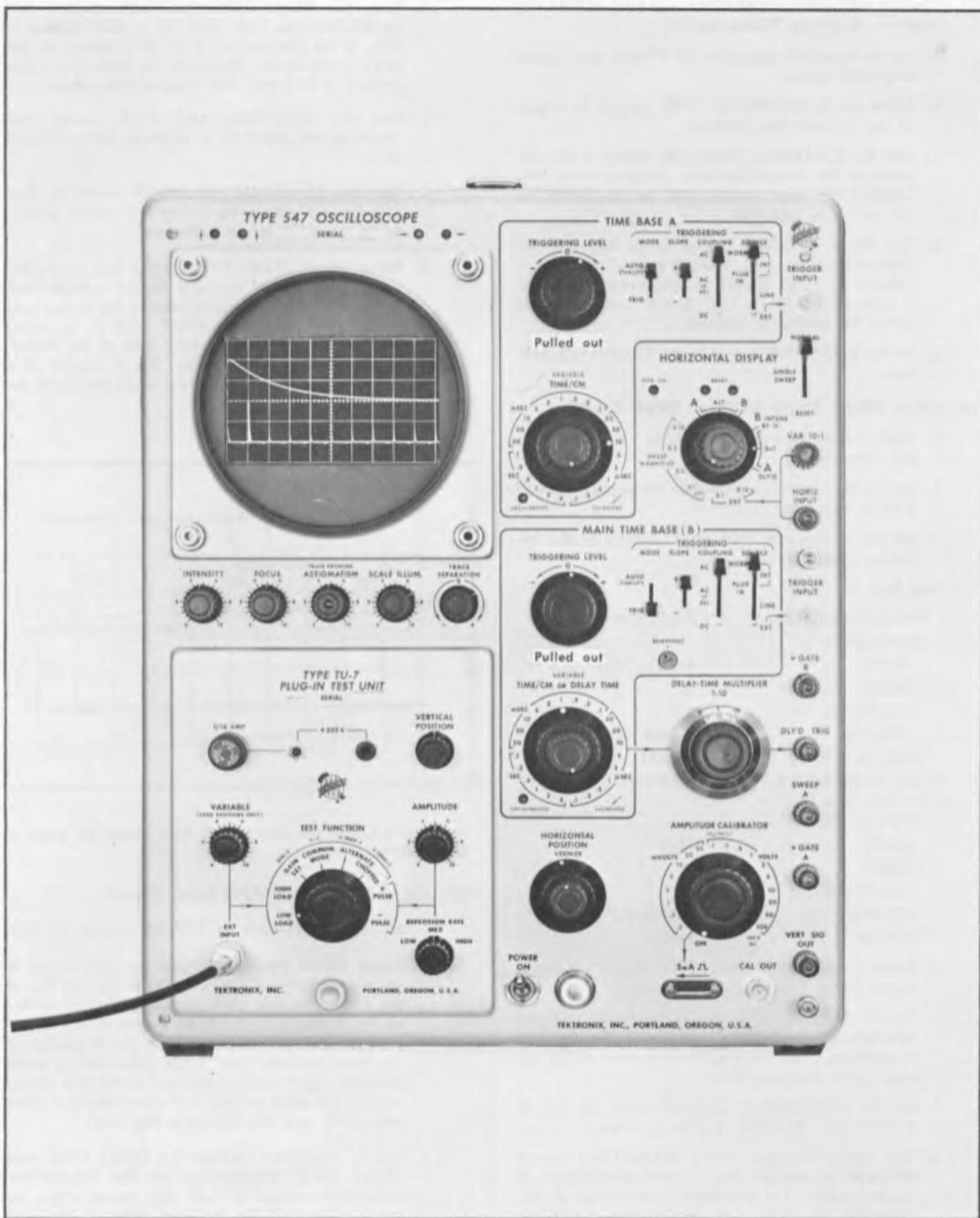

Fig. 5-11. Front-panel control settings at the completion of step 26j.

Calibration—Type 547/RM547

25. Check B VARIABLE (TIME/CM) and UNCALIBRATED Neon — B Sweep Timing Switch

- Set the time-mark generator for 10-msec and 5-msec time-mark output.
- Adjust the B TRIGGERING LEVEL control to trigger on the 10-msec time markers.
- Turn the B VARIABLE (TIME/CM) control a few degrees in the counterclockwise direction. The UNCALIBRATED neon should light as the switch on the control is activated.
- Turn the B VARIABLE control to its fully counterclockwise position. At least 25 msec of time for a distance of 10 cm should be displayed to indicate a ratio of 2.5 to 1. That is, the 5-msec markers should be spaced at intervals of 2 cm or less.
- Set the B VARIABLE control to the CALIBRATED position.

26. Adjust DELAY START R418 — Delay Pickoff

- Apply 1-msec time markers only to the TU-7 Ext Input connector.
- Set the TU-7 Variable control so the display is about 2 cm in amplitude.
- Set the oscilloscope front-panel controls to the following positions:

Time Base A

TRIGGERING LEVEL	FULLY CW
TRIGGERING	
MODE	AUTO
SLOPE	+
COUPLING	AC
SOURCE	NORM INT
TIME/CM	10 μ SEC
HORIZONTAL DISPLAY	B INTENS BY 'A'
Main Time Base (B)	
TRIGGERING	
MODE	TRIG
SLOPE	+
COUPLING	AC
SOURCE	NORM INT
TIME/CM	1 mSEC

- Adjust the B TRIGGERING LEVEL control for stable triggering on the 1-msec time markers.
- Turn the BRIGHTNESS control in the counterclockwise direction and the INTENSITY control in the clockwise direction to make the brightened portion of the display easily distinguishable.
- Set the HORIZONTAL DISPLAY switch to ALT (B INTENS BY 'A'-ALT-A DLY'D) position.
- Turn the oscilloscope TRACE SEPARATION control clockwise to position the delayed presentation (A display) above the intensified presentation (B display). Use the TU-7 and oscilloscope positioning controls to center the display vertically and to start at the left side of the graticule.

- Turn the DELAY-TIME MULTIPLIER control fully counterclockwise and check for a dial reading of 0.15. If the dial reading is not 0.15, loosen the set-screw in the knob. Reposition the knob so the dial reading is 0.15 and then retighten the set-screw.
- Turn the DELAY-TIME MULTIPLIER control fully clockwise and check for a minimum dial reading of 10.15.
- Turn the DELAY-TIME MULTIPLIER control to read 1.00. Fig. 5-11 shows the front-panel control settings up to this point in the procedure.
- Adjust DELAY START R418 (see Fig. 5-2) so the 2nd 1-msec time marker on the B display is brightened. For an accurate adjustment, observe the A time-base display and set DELAY START R418 so the rising portion, starting from the 90% level of the marker, is displayed (see Fig. 5-12). The A display is a 100X magnification of the brightened portion of the B display.

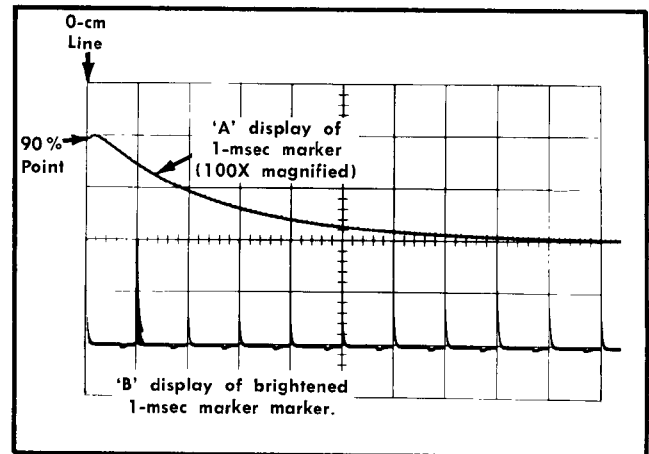

Fig. 5-12. Adjusting the DELAY START R418 control for proper A delayed-sweep starting time.

27. Adjust DELAY STOP R415 Delay Pickoff

- Set the DELAY-TIME MULTIPLIER control to 9.00.
- Adjust DELAY STOP R415 (see Fig. 5-2) so the A display starts from the 90% point on the rise of the 1-msec marker. This magnified 1-msec marker on the A display is the same marker as the brightened 1-msec marker located on the B display at the 9-cm graticule line. If the adjustment is made correctly, the A display obtained in this step should appear the same as the A display obtained when performing step 26k (shown in Fig. 5-12).
- Due to interaction between the DELAY START and DELAY STOP adjustments, set the DELAY-TIME MULTIPLIER control to 1.00 and repeat steps 26j through 27b until the A sweep starts at the same point on the 1st- and 9th-cm time markers, respectively.

28. Check Incremental Accuracy — Delay Pickoff

Set the DELAY-TIME MULTIPLIER control so the A sweep starts at the 90% point on the rising portion of the 1-msec markers for each setting as given in Table 5-4.

29. Adjust C186 (Unblanking Compensation Capacitor) B Sweep Generator

- a. Set the oscilloscope and TU-7 front-panel controls to these settings:

TU-7 Test Function Gain Set

TABLE 5-4

DELAY TIME MULTIPLIER	
Control Setting	Tolerance
1.00	0 (Adjusted)
2.00	±2.0 minor div.
3.00	±2.0 minor div.
4.00	±2.0 minor div.
5.00	±2.0 minor div.
6.00	±2.0 minor div.
7.00	±2.0 minor div.
8.00	±2.0 minor div.
9.00	0 (Adjusted)

A TRIGGERING LEVEL Fully clockwise
 A TIME/CM 50 μSEC
 HORIZONTAL DISPLAY ALT (A-ALT-B)
 B TRIGGERING LEVEL Fully clockwise
 B MODE AUTO
 B TIME/CM 50 μSEC
 BRIGHTNESS Fully clockwise
 INTENSITY Slightly below normal

- b. Adjust the TRACE SEPARATION control so the two traces are spaced 2 mm apart. Use the TU-7 Vertical Position control to center the traces on the CRT.
- c. Readjust the BRIGHTNESS control so the B trace is the same brightness as the A trace along the distance from about 2 cm to 10 cm.
- d. Adjust C186 (see Fig. 5-13) so the starting portion of the B trace is the same brightness as the starting portion of the A trace.

NOTE

C186 has the greatest effect on the first 8 mm of the B trace.

30. Adjust C90C (10-μsec B Sweep-Rate Timing to DELAY-TIME MULTIPLIER) — B Sweep Timing Switch

- a. Set the time-mark generator for a 10-μsec time-marker output.

- b. Set the TU-7 and oscilloscope front-panel controls as follows:

TU-7 Test Function Low Load
 A TIME/CM .1 μSEC
 HORIZONTAL DISPLAY ALT (B INTENS BY 'A' ALT-A DLY'D)
 B TRIGGERING LEVEL Pushed in
 B MODE TRIG
 B TIME/CM 10 μSEC
 BRIGHTNESS Near midrange
 INTENSITY Normal intensity

- c. Adjust the B TRIGGERING LEVEL control to obtain a stable display.
- d. Set the TU-7 Variable control so the B display is about 2 cm in amplitude.
- e. Turn the TRACE SEPARATION control to position the the A delayed-sweep display above the B display.
- f. Set the DELAY-TIME MULTIPLIER so the 50% point on the rising portion of the 2nd 10-μsec time marker is brightened. Use the A display to accurately determine the 50% point.
- g. Note the DELAY-TIME MULTIPLIER dial reading in relation to 1.00.
- h. Set the DELAY-TIME MULTIPLIER control to read exactly 8.00 plus the dial reading obtained in the previous step.
- i. Adjust C90C (see Fig. 5-2) so the 50% point on the rising portion of the 10th time marker is the 50% starting point on the A display.
- j. Since there is interaction which affects the dial reading obtained in step 30g, repeat steps 30f through 30i until the DELAY-TIME MULTIPLIER dial indicates a difference of exactly 8.00 between the 2nd and 10th time markers.

31. Adjust C90B (1-μsec B Sweep-Rate Timing to DELAY-TIME MULTIPLIER) — B Sweep Timing Switch

- a. Set the time-mark generator for a 1-μsec time-marker output.
- b. Set the A TIME/CM switch to .1 μSEC and the B TIME/CM switch to 1 μSEC.
- c. Adjust the TU-7 Variable control so the displays are each 2 cm in amplitude.
- d. Adjust the B TRIGGERING LEVEL control to trigger on the time markers.
- e. Set the DELAY-TIME MULTIPLIER control so the 2nd time marker on the B display is brightened starting at the 50% point on the rising portion of the marker. Use the A display to determine the 50% point accurately.
- f. Note the DELAY-TIME MULTIPLIER dial reading.

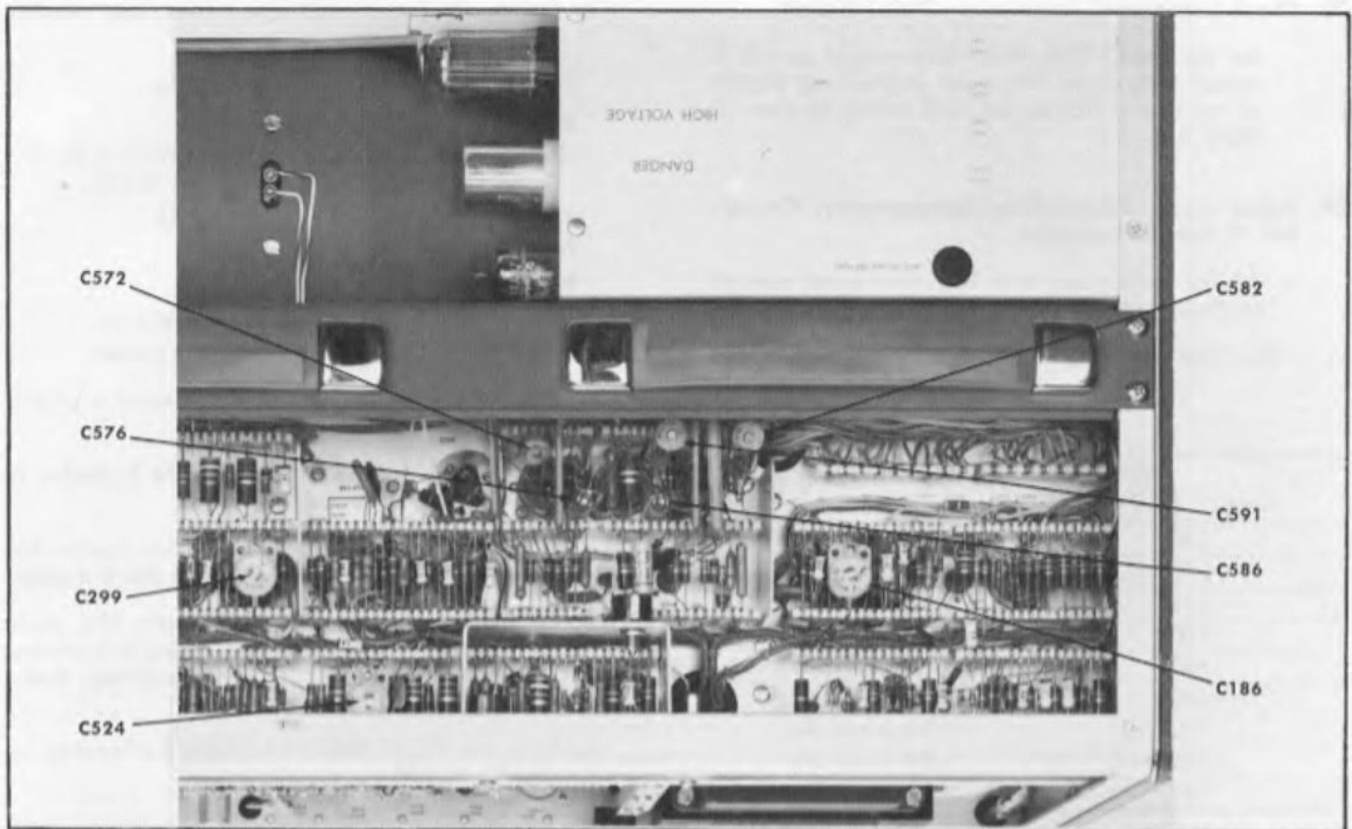

Fig. 5-13. Calibration adjustment locations.

- g. Set the DELAY-TIME MULTIPLIER control to read exactly 8.00 plus the dial reading noted in the previous step.
 - h. Adjust C90B (see Fig. 5-2) so the 50% point on the rising portion of the 10th time marker is the 50% starting point of the A display.
 - i. Due to interaction that affects the DELAY-TIME MULTIPLIER dial reading that was obtained for the 2nd time marker, repeat steps 31e through 31h until the DELAY-TIME MULTIPLIER dial indicates an exact 8.00 difference between the 2nd and 10th time markers.
- 32. Adjust C90A (0.5- μ sec B Sweep-Rate Timing to the DELAY-TIME MULTIPLIER) — B Sweep Timing Switch**
- a. Set the time-mark generator for a 5-mc sine-wave output.
 - b. Set the B TIME/CM switch to .5 μ SEC.
 - c. Adjust the TU-7 Variable control to reduce the amplitude of the display to a suitable level.
 - d. Adjust the B TRIGGERING LEVEL control to obtain stable displays.
 - e. Turn the INTENSITY control clockwise to increase the brightness of the two waveforms.
 - f. Check that the first 2 cm of the starting portion of the B display is linear. If it is not, preset C99 (see Fig. 5-2) to obtain best linearity at the starting portion of the display.
 - g. Check that there is 2 $\frac{1}{2}$ cycles/cm for the remaining portion of the B display. If there is not, preadjust C90A (see Fig. 5-2) for proper timing.
 - h. For a more exact adjustment of C90A, position the B display with the HORIZONTAL POSITION control so the tip of the 6th sine wave aligns with the 2-cm graticule line.
 - i. Set the DELAY-TIME MULTIPLIER control so the brightened portion of the B display starts at the 50% point on the rising portion of the 6th sine wave. To set the DELAY-TIME MULTIPLIER control as accurately as possible, use the A display to determine the 50% point.
 - j. Note the DELAY-TIME MULTIPLIER dial reading. It should read approximately 2.00.
 - k. Set the DELAY-TIME MULTIPLIER control to 7.00 plus the reading noted in the previous step. The falling portion of the 23rd sine wave, starting at the 50% point, should be brightened as observed on the B display. Use the A display to see the 50% point clearly. If the 50% point is not obtained, adjust C90A for the correct point on the A display while

maintaining a timing of 2½ cycles/cm on the B display.

- i. Repeat steps 32h through 32k until the DELAY-TIME MULTIPLIER dial indicates an exact difference of 7.00 between the 50% point on the rising portion of the 6th sine wave and the 50% point on the falling portion of the 23rd sine wave. The last half cycle of the 23rd sine wave is the portion of the B display that aligns with the 9-cm graticule line when correct timing of 2½ cycles/cm is obtained.

33. Adjust C99 (B Sweep Output Compensation to CRT Display) — B Sweep Generator

- a. Set the time-mark generator for 10-mc sine-wave output.
- b. Set the HORIZONTAL DISPLAY switch to B.
- c. Set the B TIME/CM switch to .1 μSEC.
- d. Use the TU-7 Vertical Position control to center the display vertically.
- e. Using the oscilloscope HORIZONTAL POSITION control, position the tip of the 2nd sine wave to align with the 1-cm graticule line.
- f. Adjust C99 for correct timing of 1 cycle/cm.
- g. Due to interaction between the adjustment of C99 and C90A, repeat the procedure for these adjustments outlined in steps 32a through 33f until the desired results are obtained.

34. Check 0.2-μsec/cm Sweep Rate—B Sweep Timing Switch

- a. Set the HORIZONTAL DISPLAY switch to the ALT (B INTENS BY 'A'-ALT-A DLY'D) position.
- b. Set the B TIME/CM switch to .2 μSEC.
- c. Center the display vertically. The A display should be located above the B display.
- d. Horizontally position the displays so the 2nd sine wave of the B display coincides with the 2 cm graticule line.
- e. Set the DELAY-TIME MULTIPLIER control so the 50% point starting on the rising portion of the 2nd sine wave is brightened on the B display. Use the A display to determine the 50% point.
- f. Note the DELAY-TIME MULTIPLIER dial reading.
- g. Turn the DELAY-TIME MULTIPLIER control clockwise until the 50% point starting on the rising portion of the sine wave at the 9-cm graticule line is brightened. Use the A display to determine the 50% point. Note the dial reading.
- h. The difference between the dial reading noted in step 34f and the one noted in step 34g should be 7.00 within a tolerance of ±7 minor divisions.
- i. Set the B TIME/CM switch to .5 μSEC. Recheck the B 0.5 μsec sweep-rate timing using the DELAY-TIME

MULTIPLIER control and a 5-mc sine-wave input from the time-mark generator. Timing accuracy: ±1%.

35. Check 2-μsec through 5-sec/cm Sweep Rates — B Sweep Timing Switch

- a. Using Table 5-5 as a guide, check the Main Time Base (B) sweep rates from 2 μsec through 50 msec. Use the DELAY-TIME MULTIPLIER control to determine sweep-rate accuracy. First note the dial readings near the 1.00 setting of the DELAY-TIME MULTIPLIER dial for the sweep rate being checked. Do not move the B TRIGGERING LEVEL control after obtaining the reading. Then note the dial reading obtained near the 9.00 position for the same sweep rate. Next, determine the difference between the two dial readings. This difference should be 8.00 within a tolerance of ±1%. Check each sweep rate in Table 5-5 using this method.

TABLE 5-5

B TIME/CM Switch Setting	A TIME/CM Switch Setting	Time-Mark Generator Output	Markers/Cm on B Display
2 μSEC	.1 μSEC	1 μsec	2
5 μSEC	.1 μSEC	5 μsec	1
10 μSEC*	1 μSEC	10 μsec	1
20 μSEC	1 μSEC	10 μsec	2
50 μSEC	1 μSEC	50 μsec	1
.1 mSEC	10 μSEC	100 μsec	1
.2 mSEC	10 μSEC	100 μsec	2
.5 mSEC	10 μSEC	500 μsec	1
1 mSEC*	.1 mSEC	1 msec	1
2 mSEC	.1 mSEC	1 msec	2
5 mSEC	.1 mSEC	5 msec	1
10 mSEC	1 mSEC	10 msec	1
20 mSEC	1 mSEC	10 msec	2
50 mSEC	1 mSEC	50 msec	1

*Adjusted previously.

- b. Using Table 5-6 as a guide, check the sweep rates from 0.1 sec/cm through 5 sec/cm. Use the same procedure as outlined in step 35a.

When checking each of these sweep rates, set the HORIZONTAL DISPLAY switch to B INTENS BY 'A' to check that the proper number of markers/cm are obtained and to set the DELAY-TIME MULTIPLIER control so the marker at the 1-cm graticule line is brightened. Then, set the HORIZONTAL DISPLAY switch to A DLY'D and use the DELAY-TIME MULTIPLIER control to determine the exact point on the marker where the delayed sweep should start. Note the dial reading. Use this same method to obtain the dial reading from 9.00. Determine the difference which should be 8.00 within a tolerance of ±1%.

TABLE 5-6

B Time/Cm Switch Setting	A Time/Cm Switch Setting	Time-Mark Generator Output	Markers/Cm on B Display
.1 SEC	10 mSEC	100 msec	1
.2 SEC	10 mSEC	100 msec	2
.5 SEC	10 mSEC	500 msec	1
1 SEC	.1 SEC	1 sec	1
2 SEC	.1 SEC	1 sec	2
5 SEC	.1 SEC	5 sec	1

36. Adjust C572 and C582 (High-Speed Sweep Length Compensation) — Horizontal Amplifier.

a. Set the oscilloscope front-panel controls to these settings:

HORIZONTAL DISPLAY B
 B SOURCE EXT
 B TIME/CM .1 μSEC

- b. Set the time-mark generator for a 50-mc sine-wave output.
- c. Connect a coaxial cable from the trigger output of the time-mark generator to the B TRIGGER INPUT connector.
- d. Set the trigger rate of the time-mark generator for a 10-μsec trigger output.
- e. Adjust the INTENSITY control so the display is easily visible and adjust the B TRIGGERING LEVEL control to obtain a stable display.
- f. Adjust the HORIZONTAL POSITION control to position the display at start at the 0-cm line of the graticule.
- g. Check that C576 and C586 (see Fig. 5-13) slug-adjusting screws are about six turns above the metal wiper contacts of the capacitors.
- h. Set the SWEEP MAGNIFIER switch to X10.
- i. Adjust C572 and C582 (see Fig. 5-13) for maximum center-sweep expansion. (Use a low-capacitance alignment tool when making the adjustments.) These two capacitors should be adjusted to nearly the same physical setting.

37. Adjust C591 (High-Speed Sweep Linearity) — Horizontal Amplifier

Adjust C591 (see Fig. 5-13) for best center-sweep linearity of 1 cycle/2 cm.

38. Adjust C576 and C586 (High-Speed Timing Adjustments) — Horizontal Amplifier

Adjust C576 and C586 in equal increments for best timing of 1 cycle/2 cm from the 2-cm graticule line to the 8-cm graticule line.

39. Adjust C557H (X10 SWEEP MAGNIFIER Compensation) — Horizontal Amplifier

a. Turn the HORIZONTAL POSITION control clockwise so the start of the sweep (or display) can be

seen. Then, position the tip of the 4th cycle from the start of the sweep to coincide with the 4-cm graticule line.

- b. Adjust C557H (see Fig. 5-2) for best timing of 1 cycle/2 cm from the 4-cm to 10-cm graticule lines.
- c. Set the SWEEP MAGNIFIER switch to OFF.
- d. Using the HORIZONTAL POSITION and VERNIER controls, position the display to the left so the 10th-cm portion of the sweep coincides with the 7-cm graticule line.
- e. Set the SWEEP MAGNIFIER switch to X10.
- f. Note the timing error of the display from the 1-cm to the 9-cm graticule lines; it should be within 5%.

40. Check Timing Accuracy — Horizontal Amplifier

Check the timing accuracy of the display between the 4th cm and 80th cm of the sweep. Magnified-timing in this region must be within 5% or less. If, in the 20th cm region some nonlinearity is observed, readjust C591 to make the sweep more linear.

NOTE

If the adjustments in steps 36 through 40 are accurate, the magnified sweep timing can be adjusted to better than ±5%.

41. Adjust C557F (X5 SWEEP MAGNIFIER Compensation) — Horizontal Amplifier

- a. Set the SWEEP MAGNIFIER switch to X5.
- b. Adjust C557F (see Fig. 5-2) for 1 cycle/cm after the first 2 cm from the start of the sweep.

42. Adjust C557D (X2 SWEEP MAGNIFIER Compensation) — Horizontal Amplifier

- a. Set the SWEEP MAGNIFIER switch to X2.
- b. Adjust C557D (see Fig. 5-2) for 2½ cycles/cm after the first cm from the start of the sweep.

43. Adjust A SWEEP DC LEVEL R470 — Alternate Sweep Switching

- a. Set the time-mark generator for 100-μsec time-marker output.
- b. Set the front-panel controls of the oscilloscope to these settings (some of the controls need not be changed since they are already set properly):

A and B TRIGGERING
 TRIGGERING LEVEL Pushed in
 MODE AUTO
 SLOPE +
 COUPLING AC
 SOURCE NORM INT
 A and B TIME/CM 1 mSEC
 HORIZONTAL DISPLAY ALT (A-ALT-B)
 SWEEP MAGNIFIER X1 OFF

- c. Set the TU-7 Variable control so the markers are 3 cm in amplitude.
- d. Adjust the HORIZONTAL POSITION control so both sweeps start near the center of the crt.
- e. Set the SWEEP MAGNIFIER switch to $\times 10$ (re-center start of sweep if necessary).
- f. Adjust A and B TRIGGERING LEVEL controls to start each sweep on a time marker.
- g. Adjust TRACE SEPARATION control to superimpose the two displays. Fig. 5-14 shows the front-panel setup thus far in the procedure.
- h. Adjust A SWEEP DC LEVEL R470 (see Fig. 5-2) so the start of the A sweep coincides with the start of the B sweep.

44. Adjust A SWEEP LENGTH R325 — A Sweep Generator

- a. Set the HORIZONTAL POSITION and VERNIER controls so the end of the B sweep is located near the center of the crt.
- b. Set the A SWEEP LENGTH R235 (see Fig. 5-2) so the A sweep length equals the sweep length of the B sweep.

45. Adjust A SWP CAL R290Y — A Sweep Timing Switch

Adjust A SWP CAL R290Y (see Fig. 5-2) so that each time marker on the A sweep display coincides with the corresponding time marker on the B sweep display.

46. Check A VARIABLE (TIME/CM) and UNCALIBRATED Neon — A Sweep Timing Switch

- a. Set the time-mark generator for a 10-msec and 5-msec time-marker output.
- b. Set the HORIZONTAL DISPLAY switch to A and the SWEEP MAGNIFIER switch to $\times 1$ OFF.
- c. Set the HORIZONTAL POSITION control to position the display to start at the 0-cm graticule line.
- d. Adjust the TU-7 Variable control so the 10-msec markers are about 3-cm in amplitude.
- e. Adjust the A TRIGGERING LEVEL control to trigger the sweep on the 10-msec markers.
- f. Turn the A VARIABLE (TIME/CM) control a few degrees in the counterclockwise direction. Check that the UNCALIBRATED neon lights as the switch on the control is activated.
- g. Turn the A VARIABLE control to its fully counterclockwise position. At least 25 msec of time for a distance of 10 cm should be displayed to indicate a ratio of at least 2.5 to 1.
- h. Set the A VARIABLE control to the CALIBRATED position.

47. Adjust C290C (10- μ sec A Sweep-Rate Timing) — A Sweep Timing Switch

- a. Set the time-mark generator for a 10- μ sec time marker output.
- b. Set the oscilloscope front-panel controls to the following settings:

A and B TIME/CM	10 μ SEC
HORIZONTAL DISPLAY	ALT (A-ALT-B)
- c. Set the TU-7 Variable control so the markers are about 3 cm in amplitude.
- d. Adjust the A and B TRIGGERING LEVEL controls to trigger on the 10- μ sec time markers.
- e. Check that the TRACE SEPARATION control is set to superimpose the displayed waveforms.
- f. Adjust C290C (see Fig. 5-2) so that each time marker displayed by the A sweep coincides with the corresponding time marker on the B sweep.

NOTE

For better accuracy, position the 2nd marker to graticule center using the HORIZONTAL POSITION control. Then set the SWEEP MAGNIFIER switch to $\times 10$. Adjust the A and B TRIGGERING LEVEL controls carefully so the tips of the 2nd markers coincide. Set the SWEEP MAGNIFIER switch to $\times 1$ OFF and position the 10th marker to graticule center. Set the SWEEP MAGNIFIER switch to $\times 10$. If the 10th A display marker does not coincide with the 10th B display marker, readjust C290C for proper matching of markers.

- g. Set the SWEEP MAGNIFIER switch to $\times 1$ OFF.
- h. Position the sweeps to start at the 0-cm graticule line.

48. Adjust C290B (1- μ sec A Sweep-Rate Timing) — A Sweep Timing Switch

- a. Set the time-mark generator for a 1- μ sec time-marker output.
- b. Set the A and B TIME/CM switches to 1 μ SEC.
- c. Set the TU-7 Variable control so the markers are about 3 cm in amplitude.
- d. Adjust C290B (see Fig. 5-2) so that each time marker displayed by the A sweep exactly coincides with the corresponding time marker on the B sweep.

NOTE

If exact matching of markers cannot be obtained by adjusting C290B, proceed to the next step since C299 affects the linearity of the A sweep for the first one half of the sweep. Repeat steps 48 and 49 until A sweep timing matches the B sweep timing as close as possible.

(To obtain best accuracy when adjusting C290B and C299, use the same basic procedure as described in the NOTE following step 47f).

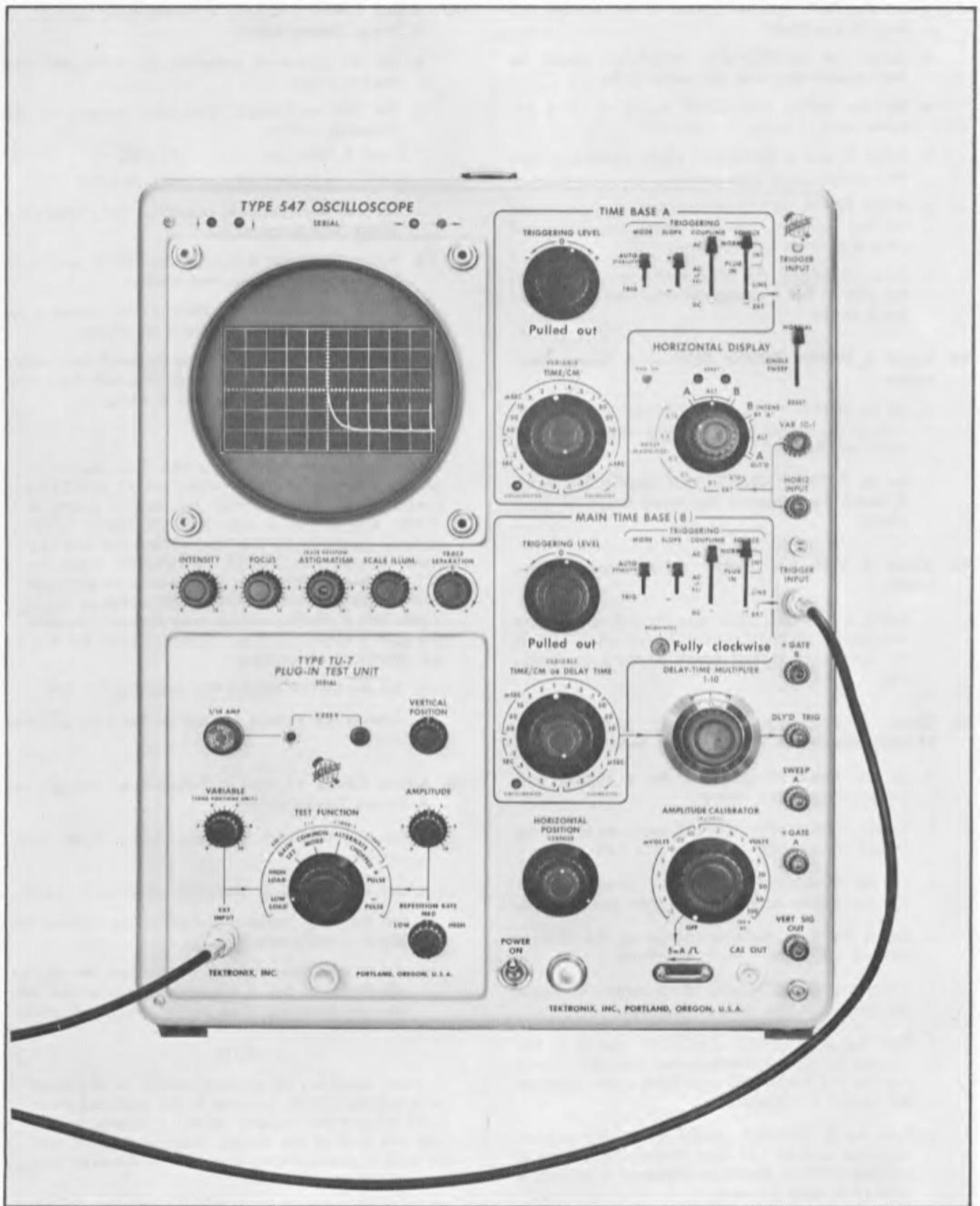

Fig. 5-14. Front-panel control settings at the completion of step 43g.

49. Adjust C299 (A Sweep Output Compensation) — A Sweep Generator

- a. If the markers do not coincide accurately when adjusting C290B due to some nonlinearity in the A sweep, adjust C299 (see Fig. 5-13) for best linearity for the first half of the A sweep.
- b. Readjust C290B for correct matching of marker. at the end of the A sweep. Adjust C290B and C299 for best matching of the A display to the B display.
- c. Check that the SWEEP MAGNIFIER switch is set to X1 OFF and the displays are positioned to start at the 0-cm graticule line.

50. Adjust C290A (0.5- μ sec A Sweep-Rate Timing) — A Sweep Timing Switch

- a. Set the time-mark generator for a 5-mc sine-wave output.
- b. Set the A and B TIME/CM switches to .5 μ SEC
- c. Use the TU-7 Variable control to reduce the amplitude of the displays to about 4-cm.
- d. Adjust the A and B TRIGGERING LEVEL controls for two stable sine-wave displays whose first few cycles coincide.
- e. Adjust C290A (see Fig. 5-2) so that each cycle after the first 5 cycles of the A display exactly coincides with the corresponding cycles of the B display. Use the X10 position of the SWEEP MAGNIFIER switch to magnify the display to make the adjustment more accurate.

51. Readjust C299 (0.1- μ sec A Sweep-Rate Timing) — A Sweep Generator

- a. Set the time-mark generator for a 10-mc sine wave output.
- b. Set the A and B TIME/CM switches to .1 μ SEC.
- c. Adjust the A and B TRIGGERING LEVEL controls for two stable sine-wave displays whose first few cycles coincide.
- d. Readjust C299 to make the A display match the B display. Use the X10 position of the SWEEP MAGNIFIER switch for more exact adjustment.
- e. Repeat steps 50a through 51d for the most accurate matching of the A sweep to the B sweep.

52. Check 0.1- μ sec/cm Through 5-sec/cm Sweep Rates — A Sweep Timing Switch

- a. Check that the A TIME/CM switch is set to .1 μ SEC.
- b. Starting with the 0.1- μ sec/cm sweep rate, check each of the Time Base A sweep rates using Table 5-7 as a guide. Tolerance for the fixed (nonadjustable) sweep rates is $\pm 2\%$.

NOTE

If you prefer, leave the HORIZONTAL DISPLAY switch at A-ALT-B and compare the sweep-rate

timing of A with B on sweep rates from 0.1 μ sec/cm to 50 msec/cm. Sweep rates slower than 50 msec/cm can best be checked by setting the HORIZONTAL DISPLAY switch to A and checking the A sweep-rate timing with the graticule. At the slower sweep rates position the base of the marker display downward out of view and observe the tips of the markers.

- c. After checking the sweep rates, disconnect the time-mark generator and interconnecting cables from the oscilloscope/TU-7 combination.

TABLE 5-7

A and B TIME/CM Switch Settings	Time-Mark Generator Output	Check For
.1 μ SEC*	10 mc	1 cycle/cm
.2 μ SEC	5 mc	1 cycle/cm
.5 μ SEC*	1 μ sec	1 marker/2 cm
1 μ SEC*	1 μ sec	1 marker/cm
2 μ SEC	1 μ sec	2 markers/cm
5 μ SEC	5 μ sec	1 marker/cm
10 μ SEC*	10 μ sec	1 marker/cm
20 μ SEC	10 μ sec	2 markers/cm
50 μ SEC	50 μ sec	1 marker/cm
.1 mSEC	100 μ sec	1 marker/cm
.2 mSEC	100 μ sec	2 markers/cm
.5 mSEC	500 μ sec	1 marker/cm
1 mSEC*	1 msec	1 marker/cm
2 mSEC	1 msec	2 markers/cm
5 mSEC	5 msec	1 marker/cm
10 mSEC	10 msec	1 marker/cm
20 mSEC	10 msec	2 markers/cm
50 mSEC	50 msec	1 marker/cm
.1 SEC**	100 msec	1 marker/cm
.2 SEC**	100 msec	2 markers/cm
.5 SEC**	500 msec	1 marker/cm
1 SEC**	1 sec	1 marker/cm
2 SEC**	1 sec	2 markers/cm
5 SEC**	1 sec	1 marker/cm

*Adjust previously for exact timing.

**Set HORIZONTAL DISPLAY switch to A and the A TIME/CM switch to this setting.

53. Adjust EXT HORIZ DC BAL R519 — (External) Horizontal Amplifier

- a. Set the front-panel controls of the oscilloscope and TU-7 to the following settings:

Oscilloscope	
A TRIGGERING LEVEL	Fully clockwise, pushed in
A MODE	AUTO
A SLOPE	+
A COUPLING	AC

Calibration—Type 547/RM547

A SOURCE	EXT
A TIME/CM	1 mSEC
HORIZONTAL DISPLAY	EXT $\times 1$
VAR 10-1	Fully clockwise
B TRIGGERING LEVEL	Fully counterclockwise

Type TU-7

Vertical Position	Centered
Test Function	Low Load
Variable	2.5

- Connect the single binding-post adapter to the TU 7 Ext Input connector.
- Connect an interconnecting lead from the adapter at the TU-7 Ext Input connector to the SWEEP A connector on the oscilloscope.
- Connect an interconnecting lead from the HORIZ INPUT connector to ground.
- Using the HORIZONTAL POSITION control, position the vertical free-running sweep to the center of the graticule. Adjust the INTENSITY control, if necessary, to make the trace visible.
- Adjust EXT HORIZ DC BAL R519 (see Fig. 5-2) for no horizontal shift of the vertical trace as the VAR 10-1 control is turned.
- Disconnect the interconnecting lead from the HORIZ INPUT connector to ground.

54. Adjust C524 Output Compensation — (External) Horizontal Amplifier

- Connect a BNC T connector to the oscilloscope CAL OUT connector.
- Connect a coaxial cable from one end of the BNC T connector to the A TRIGGER INPUT connector.
- Connect another coaxial cable from the other end of the BNC T connector through the coaxial connector adapter to the HORIZ INPUT connector.
- Set the AMPLITUDE CALIBRATOR switch to 5 VOLTS and adjust the A TRIGGERING LEVEL control to obtain a stable display.
- Check that the VAR 10-1 control is set fully clockwise.
- Set the HORIZONTAL POSITION control so the display is centered on the crt.
- Set the TU-7 variable control so several cycles of the calibrator waveform are displayed (see Figs. 15a and 15b).
- Adjust C524 (see Fig. 5-13) for the least distorted calibrator waveform (see Fig. 5-15a); that is, for minimum fast spike or rolloff.

55. Check Gain — (External) Horizontal Amplifier

- Set the AMPLITUDE CALIBRATOR switch to .1 VOLTS and check that the VAR 10-1 control is set fully clockwise.
- Adjust the A TRIGGERING LEVEL control to obtain a stable display.
- The calibrator waveform displayed on the crt should be greater than 1 cm in amplitude.

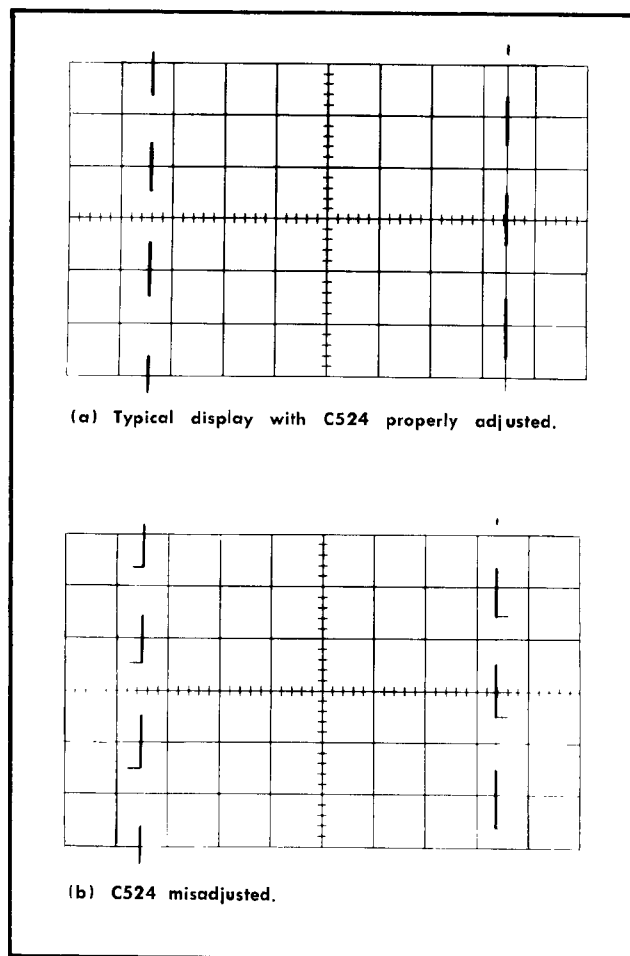

Fig. 5-15. Typical waveform displays with C524 both properly adjusted and misadjusted.

56. Check VAR 10-1 Control Range — (External) Horizontal Amplifier

- Set the AMPLITUDE CALIBRATOR switch to .5 VOLTS.
- Note the waveform amplitude in cm.
- Turn the VAR 10-1 control fully counterclockwise.
- Check that the waveform amplitude is 1/10, or less of that noted in step 56b.
- Turn the VAR 10-1 control fully clockwise.

57. Adjust C503C ($\times 10$ Attenuator Compensation) -- (External) Horizontal Amplifier

- a. Set the HORIZONTAL DISPLAY switch to EXT $\times 10$.
- b. Set the AMPLITUDE CALIBRATOR switch to 5 VOLTS.
- c. Adjust C503C (see Fig. 5-2) for optimum square-wave response. (Fig. 5-16 shows one form of distortion if C503C is misadjusted.) The display should exhibit no more than 5% hook on the positive-going or negative-going portion of the calibrator waveform. When C503C is properly adjusted, the calibrator waveform should be similar to the display shown in Fig. 5-15a.

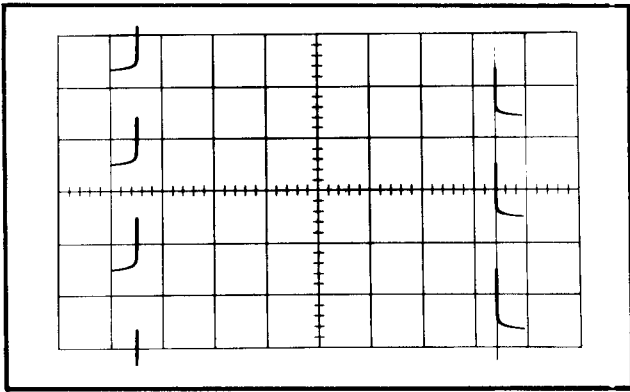

Fig. 5-16. Distortion obtained when C503C is misadjusted.

58. Check $\times 10$ Attenuation — (External) Horizontal Amplifier

- a. Set the HORIZONTAL DISPLAY switch to EXT $\times 1$ and check that the VAR 10-1 control is set fully clockwise.
- b. Set the AMPLITUDE CALIBRATOR switch to 5 VOLTS.
- c. Note the waveform amplitude in cm.
- d. Set the HORIZONTAL DISPLAY switch to EXT $\times 10$.
- e. Set the AMPLITUDE CALIBRATOR switch to 5 VOLTS and check the amplitude of the display. The signal amplitude should be within $\pm 3\%$ of that amplitude noted in step 58c.
- f. Set the HORIZONTAL DISPLAY switch to B.
- g. Disconnect the adapters, interconnecting lead and coaxial cables.

59. Check and/or Adjust High-Frequency Compensation — Vertical Amplifier

NOTE

For optimum adjustment of frequency response a modified Test Plug-in (Load Pulser), 067-0521-01 is recommended. The adjustment may also be accomplished with the Test Plug-in (Load Pulser), 067-0521-00. Both methods are described below.

Method 1 (Using Test Plug-in 067-0521-01)

1. Same procedure as Step 59 a through g, except set the B TIME/CM switch to $.1 \mu\text{Sec}$ and set the 067-0521-01 Repetition Rate switch to 4 kHz.
2. Adjust R1091 for the best square corner on the top of the display.
3. Set the 067-0521-01 Repetition Rate switch to 15 kHz and the B TIME/CM switch to $20 \mu\text{Sec}$.
4. Adjust R1077 for the best square corner on the top of the display.
5. Set the 067-0521-01 Repetition Rate switch to 80 kHz and the B TIME/CM switch to $.1 \mu\text{Sec}$.
6. Continue with Step 59 h, i, j and k.

Method 2 (Using Test Plug-in 067-0521-00)

1. Same procedure as Step 59 a through g, except set the 067-0521-00 Repetition Rate switch to low.
2. Adjust R1091 for the best square corner on the top of the display.
3. Set the 067-0521-00 Repetition Rate switch to Med and the B TIME/CM switch to $10 \mu\text{Sec}$.
4. Adjust R1077 for the best square corner on the top of the display.
5. Set the B TIME/CM switch to $.1 \mu\text{Sec}$.
6. Continue with Step 59 h, i, j and k.

- a. Set the front-panel controls of the oscilloscope to the following positions:

B TRIGGERING LEVEL	Near 0
B SOURCE	NORM INT
B TIME/CM	$.1 \mu\text{SEC}$
SWEEP MAGNIFIER	$\times 1$
BRIGHTNESS	Fully clockwise
AMPLITUDE CALIBRATOR	OFF

- b. Set the TU-7 front-panel controls as follows:

Vertical Position	Centered
Test Function	+ Pulse

- c. Using the oscilloscope HORIZONTAL POSITION control, position the display to start near the graticule center.
- d. Set the TU-7 Amplitude and Vertical Position controls so the display is vertically centered on the crt and the amplitude of the step-waveform is exactly 4 cm. (See Fig. 5-17 for complete front-panel setup at this point in the procedure.)
- e. Using the TU-7 Vertical Position control, position the waveform downward about 2 mm for better visibility (away from the graticule lines).
- f. Adjust the INTENSITY control to increase the brightness of the display to normal viewing level.

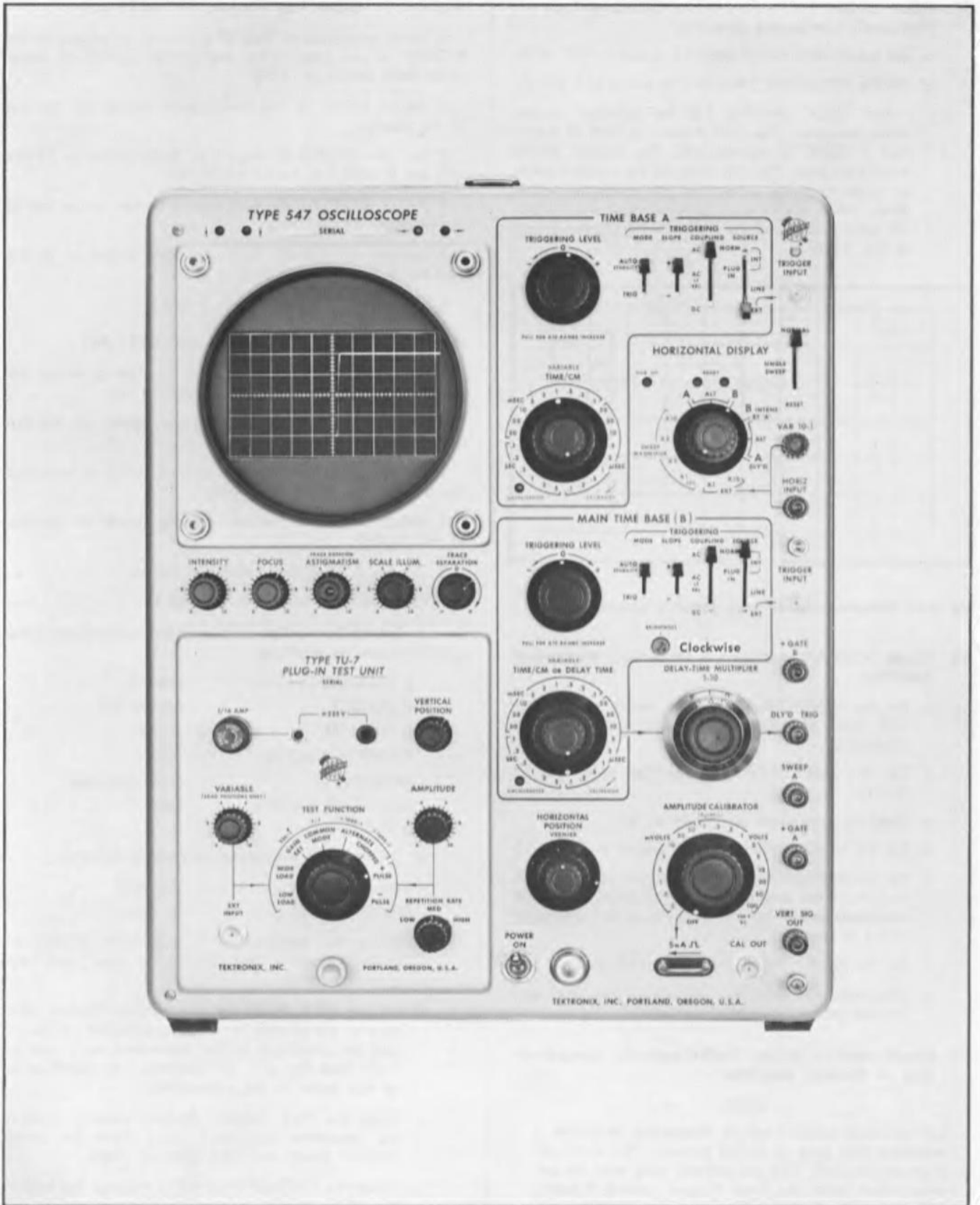

Fig. 5-17. Front-panel control settings at the completion of step 59d.

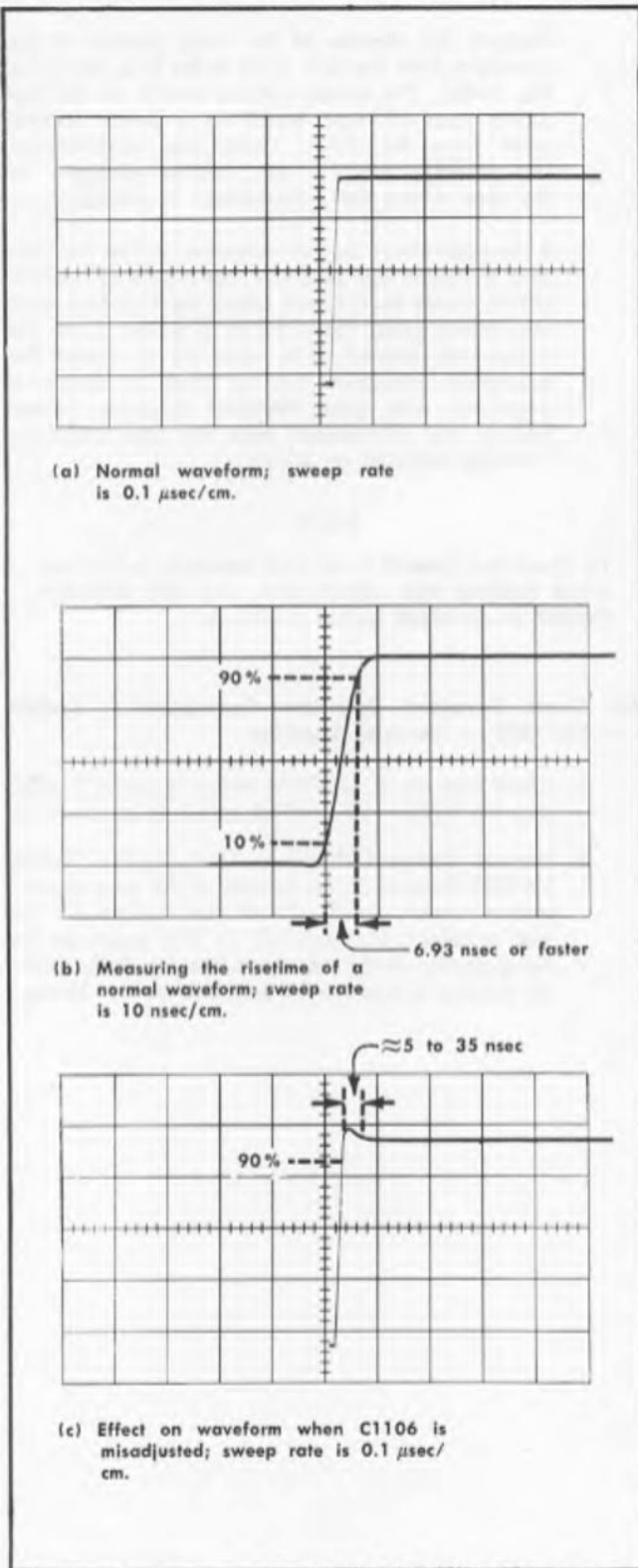

Fig. 5-18. Check of compensation adjustments for optimum Vertical Amplifier transient response.

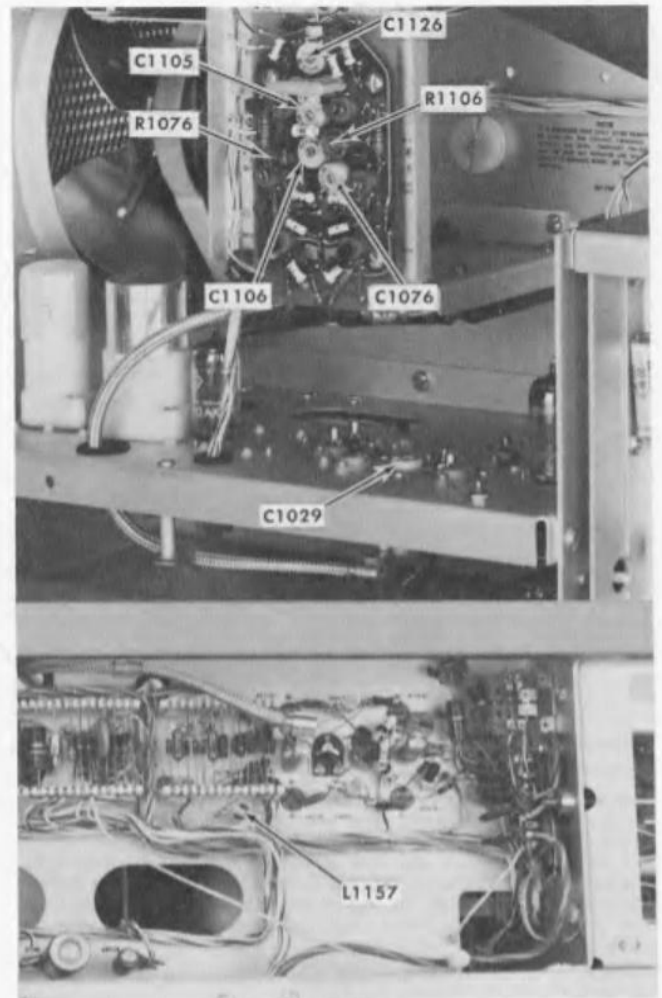

Fig. 5-19. (a) Vertical Amplifier high-frequency adjustments and Transient Response Compensation switch locations. (b) L1157 location.

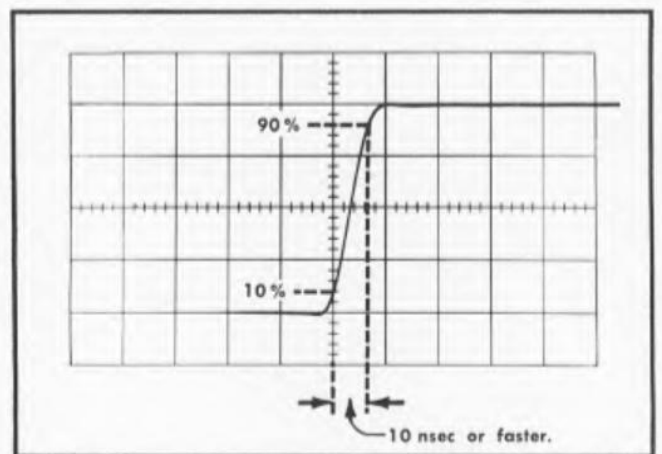

Fig. 5-20. Measuring the risetime of a normal waveform when SW1000 is actuated; sweep rate is 10 nsec/cm .

Calibration—Type 547/RM547

- g. Adjust the FOCUS and ASTIGMATISM controls to produce a well-defined leading top corner on the step waveform.
- h. Examine the waveform for clean transient response. Typical waveform should appear similar to Fig. 5-18a.

TABLE 5-8

Vertical Amplifier High-Frequency Adjustments

Adjustment	For Location See Fig.	Approximate Area Affected*
L1157	5-19B	0-100 nsec, adjust for minimum wrinkle.
¹ C1027	Located on terminals of VERT GAIN POT R1010 5-4	10% to 100% on the rising portion of the step function.
² C1029	5-19a	Termination bump at 340 ns.
C1076	5-19a	0-15 nsec
C1105	5-19a	1 nsec to 4 nsec
C1106	5-19a	5 nsec to 35 nsec
C1126	5-19a	20 nsec to 80 nsec
R1076	5-19a	0 to 10 nsec
R1106	5-19a	2 nsec to 20 nsec

*Distance measured to the right starting from 90% point on the rising portion of the waveform. For example on Fig. 5-18c.

¹Adjust C1027 for a system risetime of 6.93 nsec or faster; based on a 3 nsec risetime pulse from the TU-7. (If C1027 is adjusted for a risetime considerably faster than 6.93 nsec and aberrations are difficult to smooth out with remaining adjustments, then make the system risetime slower, towards 6.93 nsec, by readjusting C1027. Minimize the aberrations by readjusting all of the adjustments below C1027 in Table 5-8.) This adjustment applicable for 5N 4750-up.

²If there is no termination bump, adjust C1029 for a low of C if possible, or for the fastest risetime.

- i. Set the SWEEP MAGNIFIER switch to $\times 10$.
- j. Measure the risetime of the rising portion of the waveform from the 10% point to the 90% point (see Fig. 5-18b). The system risetime should not be any slower than 6.93 nsec based on a 3-nsec risetime pulse from the TU-7. (Take into consideration sweep-timing error, if any, and/or geometry in the area where the measurement is made.)
- k. If the aberrations appear excessive and/or the risetime is slower than 6.93 nsec, set the SWEEP MAGNIFIER switch to $\times 1$ and adjust the high-frequency adjustments using Table 5-8 as a guide. Since the adjustments interact, it is necessary to repeat the adjustment procedure several times to obtain a waveform with good transient response. When making the adjustments, keep the step waveform vertically centered on the crt.

NOTE

To check the overall level and maintain a flat top when making the adjustments, use the different SWEEP MAGNIFIER switch positions.

60. Check Transient Response Compensation Switch SW1000 — Vertical Amplifier

- a. Check that the B TIME/CM switch is set to .1 μ SEC and the SWEEP MAGNIFIER switch is set to $\times 10$.
- b. Depress Transient Response Compensation Switch SW1000 (located at the bottom of the plug-in compartment rear panel). Check the risetime of the step waveform from the 10% to 90% points on the rising portion of the waveform (see Fig. 5-20). Overall risetime should not be any slower than 10 nsec.

SECTION 6

PARTS LIST and DIAGRAMS

PARTS ORDERING INFORMATION

Replacement parts are available from or through your local Tektronix Field Office.

Changes to Tektronix instruments are sometimes made to accommodate improved components as they become available, and to give you the benefit of the latest circuit improvements developed in our engineering department. It is therefore important, when ordering parts, to include the following information in your order: Part number including any suffix, instrument type, serial number, and modification number if applicable.

If a part you have ordered has been replaced with a new or improved part, your local Tektronix Field Office will contact you concerning any change in part number.

ABBREVIATIONS AND SYMBOLS

a or amp	amperes	mm	millimeter
BHS	binding head steel	meg or M	megohms or mega (10 ⁶)
C	carbon	met.	metal
cer	ceramic	μ	micro, or 10 ⁻⁶
cm	centimeter	n	nano, or 10 ⁻⁹
comp	composition	Ω	ohm
cps	cycles per second	OD	outside diameter
crt	cathode-ray tube	OHS	oval head steel
CSK	counter sunk	p	pico, or 10 ⁻¹²
dia	diameter	PHS	pan head steel
div	division	piv	peak inverse voltage
EMC	electrolytic, metal cased	plstc	plastic
EMT	electrolytic, metal tubular	PMC	paper, metal cased
ext	external	poly	polystyrene
f	farad	Prec	precision
F & I	focus and intensity	PT	paper tubular
FHS	flat head steel	PTM	paper or plastic, tubular, molded
Fil HS	fillister head steel	RHS	round head steel
g or G	giga, or 10 ⁹	rms	root mean square
Ge	germanium	sec	second
GMV	guaranteed minimum value	Si	silicon
h	henry	S/N	serial number
hex	hexagonal	t or T	tera, or 10 ¹²
HHS	hex head steel	TD	toroid
HSS	hex socket steel	THS	truss head steel
HV	high voltage	tub.	tubular
ID	inside diameter	v or V	volt
incd	incandescent	Var	variable
int	internal	w	watt
k or K	kilohms or kilo (10 ³)	w/	with
kc	kilocycle	w/o	without
m	milli, or 10 ⁻³	WW	wire-wound
mc	megacycle		

SPECIAL NOTES AND SYMBOLS

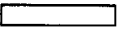
X000	Part first added at this serial number.
000X	Part removed after this serial number.
*000-000	Asterisk preceding Tektronix Part Number indicates manufactured by or for Tektronix, or reworked or checked components.
Use 000-000	Part number indicated is direct replacement.
	Internal screwdriver adjustment.
	Front-panel adjustment or connector.

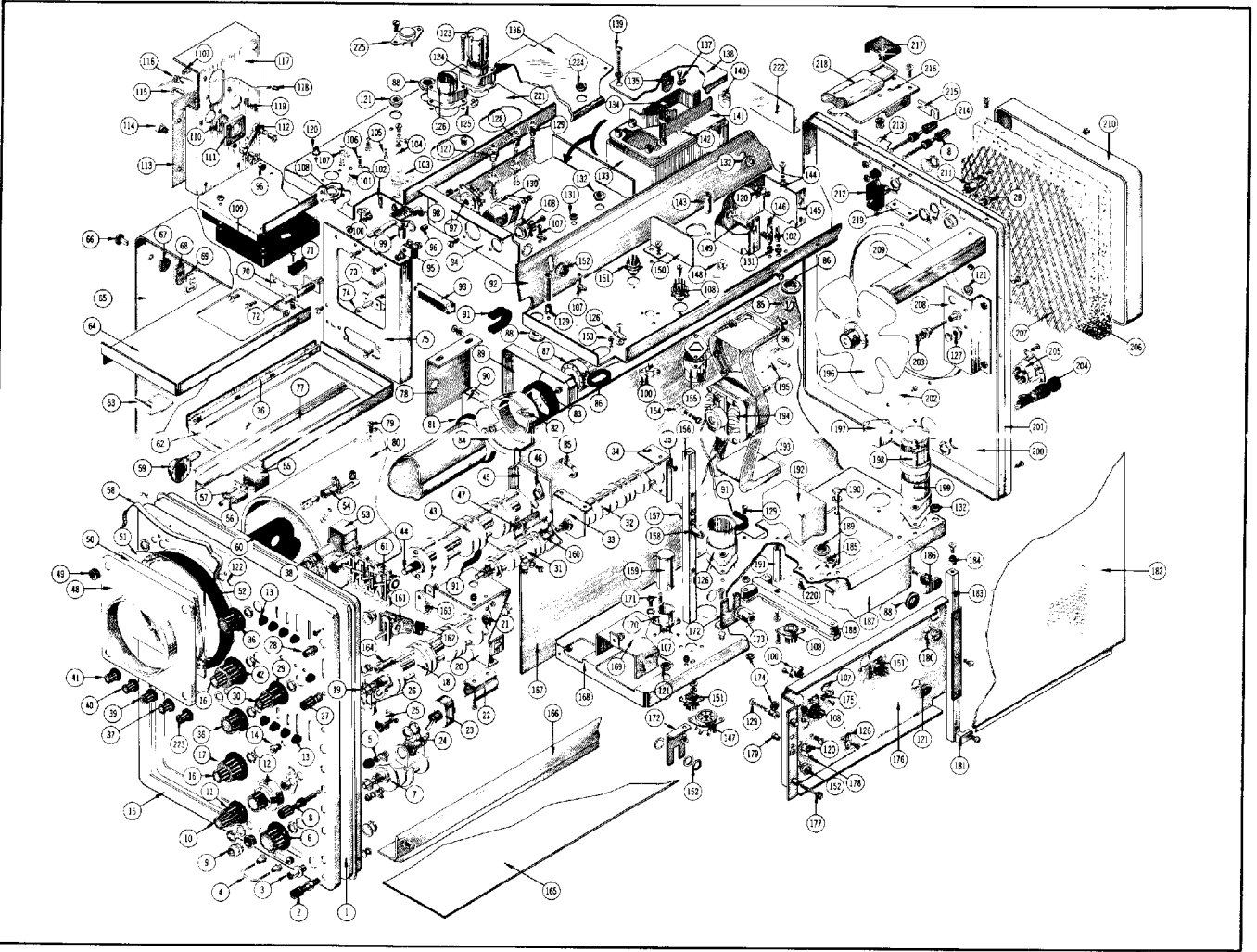

EXPLODED VIEW

REF. NO.	PART NO.	SERIAL/MODEL NO.		QTY.	DESCRIPTION
		EFF.	DISC.		
1	387-0757-00			1	PLATE, front subpanel
	- - - - -			-	Includes:
	354-0056-00			1	RING, ornamental
2	129-0020-00			2	POST, binding, assembly
	- - - - -			-	Each Consisting Of:
	355-0503-00			1	STEM, adapter
	200-0072-00			1	CAP
	- - - - -			-	Mounting Hardware For Each: (not included)
	210-0445-00			1	NUT, hex, 10-32 x $\frac{3}{8}$ inch
	210-0206-00			1	LUG, solder, SE10, long
3	131-0274-00			1	CONNECTOR, chassis mount, BNC
4	214-0335-00			1	BOLT, current loop
	- - - - -			-	Mounting Hardware: (not included)
	210-0593-00			2	NUT, current loop, hex, 5-40 x $\frac{1}{4}$ inch
	361-0059-00			1	SPACER, current loop
	210-0849-00			2	WASHER, fiber, #4
	210-0801-00			2	WASHER, 5S x $\frac{9}{32}$ inch
	210-0201-00			2	LUG, solder, SE4
	210-0442-00			2	NUT, hex, 3-48 x $\frac{3}{16}$ inch
5	210-0202-00			2	LUG, solder, SE6
	- - - - -			-	Mounting Hardware For Each: (not included)
	210-0407-00			1	NUT, hex, 6-32 x $\frac{1}{4}$ inch
6	366-0115-00			1	KNOB, AMPLITUDE CALIBRATOR, large charcoal
	- - - - -			-	Includes:
	213-0004-00			1	SCREW, set, 6-32 x $\frac{3}{16}$ inch HSS
7	262-0599-00	100	2889	1	SWITCH, AMPLITUDE CALIBRATOR, wired
	262-0731-00	2890		1	SWITCH, AMPLITUDE CALIBRATOR, wired
	- - - - -			-	Includes:
	260-0536-00			1	SWITCH, unwired
	- - - - -			-	Mounting Hardware: (not included)
	210-0413-00			1	NUT, hex, $\frac{3}{8}$ -32 x $\frac{1}{2}$ inch
	210-0012-00			2	LOCKWASHER, internal, $\frac{3}{8}$ x $\frac{1}{2}$ inch
8	129-0064-00			7	POST, binding
	- - - - -			-	Mounting Hardware For Each: (not included)
	358-0181-00			1	BUSHING, nylon, charcoal
	210-0457-00			1	NUT, keps, 6-32 x $\frac{5}{16}$ inch
9	378-0518-00	100	7209	1	JEWEL, pilot light, red
	378-0513-00	7210		1	JEWEL, pilot light, green
10	366-0032-00			1	KNOB, VERNIER, small red
	- - - - -			-	Includes:
	213-0004-00			1	SCREW, set, 6-32 x $\frac{3}{16}$ inch HSS
11	366-0159-00			1	KNOB, HORIZONTAL POSITION, large charcoal
	- - - - -			-	Includes:
	213-0004-00			1	SCREW, set, 6-32 x $\frac{3}{16}$ inch HSS
	- - - - -			-	Mounting Hardware For Pot:
	210-0413-00			1	NUT, hex, $\frac{3}{8}$ -32 x $\frac{1}{2}$ inch
	210-0012-00			1	LOCKWASHER, internal, $\frac{3}{8}$ x $\frac{1}{2}$ inch
	210-0207-00			1	LUG, solder, $\frac{3}{8}$ inch
12	331-0091-00			1	DIAL, DELAY-TIME MULTIPLIER
13	366-0215-00	100	2499	9	KNOB, lever
	366-0215-01	2500		9	KNOB, lever
14	366-0261-00	100	1969	1	KNOB, BRIGHTNESS, gray delrin
	366-0283-00	1970		1	KNOB, BRIGHTNESS, gray delrin
	- - - - -			-	Includes:
	214-0395-00			1	SPRING, wire

Parts List—Type 547

EXPLODED VIEW (Cont'd)

REF. NO.	PART NO.	SERIAL/MODEL NO.		QTY.	DESCRIPTION
		EFF.	DISC.		
15	333-0754-00			1	PANEL, front
	213-0088-00			-	Mounting Hardware: (not included)
16	366-0038-00			3	SCREW, thread forming, 4-40 x 1/4 inch PHS
	213-0004-00			2	KNOB, VARIABLE, small red
	366-0144-00			-	Each Includes:
17	213-0004-00			1	SCREW, set, 6-32 x 3/16 inch HSS
	366-0144-00			1	KNOB, "B" TIME/CM OR DELAY TIME, large charcoal
	213-0004-00			-	Includes:
18	262-0596-00	100	5309	1	SCREW, set, 6-32 x 3/16 inch HSS
	262-0596-01	5310		1	SWITCH, "B" TIME/CM OR DELAY TIME, wired
	260-0531-00			1	SWITCH, "B" TIME/CM OR DELAY TIME, wired
	384-0287-00			-	Includes:
19	376-0014-00			1	SWITCH, unwired
	361-0233-00	X12690		1	ROD, extension
	361-0234-00	X12690		1	COUPLING, pot
20	406-0898-00			1	RESTRAINT, shaft coupling
	210-0449-00			1	RESTRAINT, shaft coupling
	210-0006-00			1	BRACKET, time/cm switch "B"
	348-0003-00			-	Mounting Hardware
	210-0407-00			2	NUT, hex, 5-40 x 1/4 inch
	210-0006-00			2	LOCKWASHER, internal, #6
	210-0803-00			1	GROMMET, 5/16 inch (not shown)
21	210-0413-00			-	Mounting Hardware For Capacitor: (not shown)
	210-0012-00			3	NUT, hex, 6-32 x 1/4 inch
	210-0255-00			3	LOCKWASHER, internal, #6
	352-0061-00			2	WASHER, 6L x 3/8 inch
22	211-0008-00			-	Mounting Hardware For Pot:
	210-0004-00			2	NUT, hex, 3/8-32 x 1/2 inch
	210-0406-00			1	LOCKWASHER, internal, 3/8 x 1/2 inch
	210-0413-00			1	LUG, solder
	210-0013-00			1	HOLDER, component
	212-0004-00			-	Mounting Hardware: (not included)
	212-0023-00			2	SCREW, 4-40 x 1/4 inch BHS
	210-0804-00			2	LOCKWASHER, internal, #4
	211-0507-00			2	NUT, hex, 4-40 x 3/16 inch
	210-0803-00			-	Mounting Hardware: (not included)
23	260-0199-00			1	NUT, hex, 3/8-32 x 1/2 inch
	210-0473-00			1	LOCKWASHER, internal, 3/8 x 11/16 inch
	210-0902-00			2	SCREW, 8-32 x 5/16 inch BHS
	354-0055-00			1	SCREW, 8-32 x 3/8 inch BHS
	210-0414-00			3	WASHER, 8S x 3/8 inch
24	136-0026-00			2	SCREW, 6-32 x 5/16 inch BHS
25	352-0067-00			2	WASHER, 6L x 3/8 inch
	211-0109-00			1	SWITCH, POWER ON, toggle
	210-0406-00			-	Mounting Hardware: (not included)
				1	NUT, switch, 15/32-32 x 5/64 inch
				1	WASHER, .470 ID x 2 1/32 inch OD
				1	RING, locking switch
				1	NUT, hex, 15/32-32 x 9/16 inch
				1	SOCKET, light
				3	HOLDER, neon, single
				-	Mounting Hardware For Each: (not included)
				1	SCREW, 4-40 x 7/8 inch FHS
				2	NUT, hex, 4-40 x 3/16 inch

EXPLODED VIEW (Cont'd)

REF. NO.	PART NO.	SERIAL/MODEL NO.		QTY.	DESCRIPTION
		EFF.	DISC.		
26	262-0598-00			1	SWITCH, TRIGGERING "B", wired
	- - - - -			-	Includes:
	260-0493-00			1	SWITCH, MODE, slide
	- - - - -			-	Mounting Hardware: (not included)
	213-0141-00			2	SCREW, thread forming, 4-40 x 1/4 inch PHS phillips
	260-0494-00			1	SWITCH, COUPLING, slide
	- - - - -			-	mounting hardware: (not included)
	213-0141-00			2	SCREW, thread forming, 4-40 x 1/4 inch, PHS phillips
	260-0495-00			1	SWITCH, SOURCE, slide
	- - - - -			-	Mounting Hardware: (not included)
	213-0141-00			2	SCREW, thread forming, 4-40 x 1/4 inch PHS phillips
	260-0542-00			1	SWITCH, SLOPE, slide
	- - - - -			-	Mounting Hardware: (not included)
	213-0141-00			2	SCREW, thread forming, 4-40 x 1/4 inch PHS phillips
	406-0943-00			1	BRACKET, lever switch
	- - - - -			-	Mounting Hardware: (not included)
	210-0586-00			4	NUT, keps, 4-40 x 1/4 inch
210-0201-00			1	LUG, solder, SE4	
27	366-0153-00			1	KNOB, VAR 10-1, small charcoal
	- - - - -			-	Includes:
	213-0004-00			1	SCREW, set, 6-32 x 3/16 inch HSS
	- - - - -			-	Mounting Hardware For Miniature Pot:
	210-0583-00			2	NUT, hex, 1/4-32 x 5/16 inch
210-0940-00			1	WASHER, 1/4 ID x 3/8 inch OD	
210-0046-00			1	LOCKWASHER, internal, .400 OD x .261 inch ID	
28	131-0106-00			3	CONNECTOR, chassis mount, 1 contact, BNC
	- - - - -			-	Each Includes:
	210-0413-00			1	NUT, hex, 3/8-32 x 1/2 inch
29	210-0012-00			1	LOCKWASHER, internal, 3/8 x 1/2 inch
	366-0160-00			1	KNOB, HORIZONTAL DISPLAY, large charcoal
- - - - -			-	Includes:	
213-0004-00			1	SCREW, set, 6-32 x 3/16 inch HSS	
30	366-0038-00			1	KNOB, SWEEP MAGNIFIER, small red
	- - - - -			-	Includes:
213-0004-00			1	SCREW, set, 6-32 x 3/16 inch HSS	
31	262-0600-00			1	SWITCH, HORIZONTAL DISPLAY, front, wired
	- - - - -			-	Includes:
	260-0534-00			1	SWITCH, unwired
	- - - - -			-	Mounting Hardware: (not included)
	210-0413-00			1	NUT, hex, 3/8-32 x 1/2 inch
210-0013-00			1	LOCKWASHER, internal, 3/8 x 1 1/16 inch	

Parts List—Type 547

EXPLODED VIEW (Cont'd)

REF. NO.	PART NO.	SERIAL/MODEL NO.		QTY.	DESCRIPTION
		EFF.	DISC.		
32	262-0601-00			1	SWITCH, HORIZONTAL DISPLAY, rear, wired
	- - - - -			-	Includes:
	260-0535-00	100	4269	1	SWITCH, unwired
	260-0796-00	4270		1	SWITCH, unwired
33	406-0902-00			1	BRACKET, switch mounting
	- - - - -			-	Mounting Hardware: (not included)
	210-0413-00			1	NUT, hex, 3/8-32 x 1/2 inch
	210-0840-00			1	WASHER, .390 ID x 9/16 inch OD
	210-0012-00			1	LOCKWASHER, internal, 3/8 x 1/2 inch
34	406-0897-00			1	BRACKET, trimmer
	- - - - -			-	Mounting Hardware: (not included)
	210-0406-00			2	NUT, hex, 4-40 x 3/16 inch
	210-0004-00			2	LOCKWASHER, internal, #4
35	- - - - -			-	Mounting Hardware For Each Capacitor:
	213-0088-00			2	SCREW, thread forming, 4-40 x 1/4 inch PHS phillips
	- - - - -			-	Mounting Hardware: (not included)
	211-0507-00			2	SCREW, 6-32 x 5/16 inch BHS
	210-0457-00			2	NUT, keps, 6-32 x 5/16 inch
36	366-0117-00			2	KNOB, TRIGGERING LEVEL, large charcoal
	- - - - -			-	Each Includes:
	213-0004-00			1	SCREW, set, 6-32 x 3/16 inch HSS
	- - - - -			-	Mounting Hardware For Each Pot:
	210-0413-00			1	NUT, hex, 3/8-32 x 1/2 inch
	210-0013-00			1	LOCKWASHER, internal, 3/8 x 1 1/16 inch
	210-0207-00			1	LUG, solder, 3/8 inch
37	366-0220-00			1	KNOB, SCALE ILLUM, small charcoal
	- - - - -			-	Includes:
	213-0004-00			1	SCREW, set, 6-32 x 3/16 inch HSS
38	- - - - -			-	Mounting Hardware For Each Pot:
	210-0590-00			1	NUT, hex, 3/8-32 x 7/16 inch
	210-0840-00			1	WASHER, .390 ID x 9/16 inch OD
	210-0013-00			1	LOCKWASHER, internal, 3/8 x 1 1/16 inch
39	366-0254-00			1	KNOB, ASTIGMATISM, small charcoal
	- - - - -			-	Includes:
	213-0004-00			1	SCREW, set, 6-32 x 3/16 inch HSS
40	366-0220-00			1	KNOB, FOCUS, small charcoal
	- - - - -			-	Includes:
	213-0004-00			1	SCREW, set, 6-32 x 3/16 inch HSS
41	366-0220-00			1	KNOB, INTENSITY, small charcoal
	- - - - -			-	Includes:
	213-0004-00			1	SCREW, set, 6-32 x 3/16 inch HSS
42	366-0144-00			1	KNOB, "A" TIME/CM, large charcoal
	- - - - -			-	Includes:
	213-0004-00			1	SCREW, set, 6-32 x 3/16 inch HSS

EXPLODED VIEW (Cont'd)

REF. NO.	PART NO.	SERIAL/MODEL NO.		QTY.	DESCRIPTION
		EFF.	DISC.		
43	262-0595-00	100	5309	1	SWITCH, "A" TIME/CM, wired
	262-0595-01	5310		1	SWITCH, "A" TIME/CM, wired
	- - - - -			-	Includes:
	260-0530-00			1	SWITCH, unwired
44	384-0288-00			1	ROD, extension
	376-0014-00			1	COUPLING, pot
	361-0233-00	X12690		1	RESTRAINT, shaft coupling
	361-0234-00	X12690		1	RESTRAINT, shaft coupling
45	406-0899-00			1	BRACKET, time/cm switch "A"
	- - - - -			-	Mounting Hardware: (not included)
	210-0449-00			2	NUT, hex, 5-40 x 1/4 inch
	210-0006-00			2	LOCKWASHER, internal, #6
	348-0003-00			1	GROMMET, 5/16 inch (not shown)
	- - - - -			-	Mounting Hardware For Capacitor: (not shown)
	210-0407-00			3	NUT, hex, 6-32 x 1/4 inch
	210-0006-00			3	LOCKWASHER, internal, #6
	210-0803-00			1	WASHER, 6L x 3/8 inch
46	- - - - -			-	Mounting Hardware For Pot:
	210-0413-00			2	NUT, hex, 3/8-32 x 1/2 inch
	210-0012-00			1	LOCKWASHER, internal, 3/8 x 1/2 inch
	210-0255-00			1	LUG, solder
	- - - - -			-	Mounting Hardware For Miniature Pot:
	210-0583-00			1	NUT, hex, 1/4-32 x 5/16 inch
	210-0046-00			1	LOCKWASHER, internal, .400 OD x .261 inch ID
47	352-0061-00			1	HOLDER, component
	- - - - -			-	Mounting Hardware: (not included)
	211-0008-00			2	SCREW, 4-40 x 1/4 inch BHS
	210-0004-00			2	LOCKWASHER, internal, #4
	210-0406-00			2	NUT, hex, 4-40 x 3/16 inch
	- - - - -			-	Mounting Hardware: (not included)
	212-0001-00			3	SCREW, 8-32 x 1/4 inch BHS
	210-0804-00			3	WASHER, 8S x 3/8 inch
	210-0413-00			1	NUT, hex, 3/8-32 x 1/2 inch
	210-0013-00			1	LOCKWASHER, internal, 3/8-32 x 1 1/16 inch
48	200-0382-00	100	9999	1	COVER, graticule
	200-0896-02	10000		1	COVER, graticule
	- - - - -			-	Includes:
	354-0116-00			1	RING, ornamental
49	- - - - -			-	Mounting Hardware: (not included)
	210-0424-00			4	NUT, knurled, 3/8-24 x 3/16 inch
50	387-0917-00	100	2069	1	PLATE, light reflector
	386-0212-00	2070	9999	1	PLATE, light reflector
	386-1459-00	10000		1	PLATE, light conductor
51	- - - - -			-	SEE STANDARD ACCESSORIES PAGE
52	354-0204-00	100	9999	1	RING, CRT shockmount
	354-0321-00	10000		1	RING, CRT shockmount
	331-0191-00	X10000		1	MASK, graticule (not shown)
53	200-0269-00	100	8139	2	COVER, pot
	200-0745-00	8140		2	COVER, pot
54	136-0035-00			2	SOCKET, graticule light
	- - - - -			-	Mounting Hardware For Each: (not included)
	211-0534-00			1	SCREW, 6-32 x 5/16 inch PHS with lockwasher
	210-0457-00			1	NUT, keps, 6-32 x 5/16 inch
	166-0328-00	X390		2	SLEEVE, insulating
55	200-0534-00			1	COVER, neon holder
56	378-0541-00			9	FILTER, lens, neon light
57	352-0064-00			3	HOLDER, neon, double
	- - - - -			-	Mounting Hardware For Each: (not included)
	211-0109-00			1	SCREW, 4-40 x 7/8 inch FHS
	210-0406-00			2	NUT, hex, 4-40 x 3/16 inch

Parts List—Type 547

EXPLODED VIEW (Cont'd)

REF. NO.	PART NO.	SERIAL/ MODEL NO.		QTY.	DESCRIPTION
		EFF.	DISC.		
58	214-0433-00	100	2069	1	SPRING, light reflector
	354-0262-00	2070	9999	1	RING, light plate reflector
	378-0594-00	10000		1	REFLECTOR, light plate
59	131-0283-00			1	CONNECTOR, cable, assembly
	214-0357-00			-	Includes:
	200-0110-00			1	CONNECTOR, CRT anode spring
	432-0046-00			1	CAP, CRT anode
60	200-0112-00			1	BASE
	200-0111-00			1	COVER, CRT anode and plate assembly
	386-0647-00			-	Consisting of:
	134-0031-00			1	COVER, CRT anode
61	262-0597-00			1	PLATE, CRT anode
	260-0493-00			1	PLUG, CRT contact (not shown)
	213-0141-00			1	SWITCH, TRIGGERING, "A", wired
	260-0494-00			-	Includes:
	213-0141-00			1	SWITCH, MODE, slide
	260-0495-00			-	Mounting Hardware: (not included)
	213-0141-00			2	SCREW, thread forming, 4-40 x 1/4 inch PHS
	260-0542-00			1	SWITCH, COUPLING, slide
	213-0141-00			-	Mounting Hardware: (not included)
	406-0943-00			2	SCREW, thread forming, 4-40 x 1/4 inch PHS
	210-0586-00			1	SWITCH, SOURCE, slide
	62	210-0201-00			-
387-0755-00				2	SCREW, thread forming, 4-40 x 1/4 inch PHS
212-0040-00				1	SWITCH, SLOPE, slide
212-0004-00				-	Mounting Hardware: (not included)
210-0458-00				2	SCREW, thread forming, 4-40 x 1/4 inch PHS
344-0097-00				1	BRACKET, lever switch
387-0754-00				-	Mounting Hardware: (not included)
212-0040-00				4	NUT, keps, 4-40 x 1/4 inch
212-0010-00				2	LUG, solder, SE4
212-0004-00				1	PLATE, plug-in housing, bottom
63	210-0804-00			-	Mounting Hardware: (not included)
	210-0458-00			2	SCREW, 8-32 x 3/8 inch FHS
				2	SCREW, 8-32 x 5/16 inch BHS
				4	NUT, keps, 8-32 x 1 1/32 inch
				2	CLIP, grounding
				1	PLATE, plug-in housing, top
				-	Mounting Hardware: (not included)
				2	SCREW, 8-32 x 3/8 inch FHS
64				1	SCREW, 8-32 x 5/8 inch BHS
				4	SCREW, 8-32 x 5/16 inch BHS
				3	WASHER, 8S x 3/8 inch
				4	NUT, keps, 8-32 x 1 1/32 inch

EXPLODED VIEW (Cont'd)

REF. NO.	PART NO.	SERIAL/MODEL NO.		QTY.	DESCRIPTION	
		EFF.	DISC.			
65	387-0761-00	100	12799	1	PLATE, cabinet side, left	
	387-0761-04	12800		1	PLATE, cabinet side, left	
	-----			-	Includes:	
	134-0027-00			1	PLUG, steel	
66	214-0361-00			2	LATCH, quarter turn, assembly	
	-----			-	Each Consisting Of:	
	214-0400-00			1	PIN, securing, index	
	358-0218-00			1	BUSHING, latch bearing	
	387-0871-00			1	PLATE, latch index	
	387-0804-00			1	PLATE, latch locking	
	214-0359-00	100	6929	1	SPRING, latch	
	220-0486-00	6930		1	NUT, push-on	
	406-0903-00			1	BRACKET, micro switch mounting	
	-----			-	Mounting Hardware: (not included)	
211-0510-00		2		SCREW, 6-32 x 3/8 inch BHS		
260-0516-00		1		SWITCH		
-----		-		Mounting Hardware: (not included)		
211-0034-00		2		SCREW, 2-56 x 1/2 inch RHS		
210-0001-00		2		LOCKWASHER, internal, #2		
210-0405-00		2		NUT, hex, 2-56 x 3/16 inch		
72	384-0270-00			1	ROD, micro switch	
	214-0333-00			1	SPRING, micro switch rod	
73	260-0601-00			1	SWITCH, COMPENSATION, push	
	-----			-	Mounting Hardware For Each: (not included)	
74	211-0504-00			2	SCREW, 6-32 x 1/4 inch BHS	
	366-0271-00			1	KNOB, COMPENSATION, push	
75	387-0753-00			1	PLATE, plug-in housing, back	
	-----			-	Mounting Hardware: (not included)	
	212-0004-00			4	SCREW, 8-32 x 5/16 inch BHS	
	212-0023-00			1	SCREW, 8-32 x 3/8 inch BHS	
	210-0804-00			3	WASHER, 8S x 3/8 inch	
	212-0039-00			1	SCREW, 8-32 x 3/8 inch PHB	
	210-0458-00			1	NUT, keps, 8-32 x 11/32 inch	
	76	351-0058-00		4	GUIDE, shoe	
	77	122-0109-00			1	ANGLE, rail, top left
		-----			-	Mounting Hardware: (not included)
	78	211-0559-00			4	SCREW, 8-32 x 3/8 inch FHS
		210-0457-00			4	NUT, keps, 6-32 x 5/16 inch
		406-0995-00			1	BRACKET, support
	79	-----			-	Mounting Hardware:
		212-0001-00			4	SCREW, 8-32 x 1/4 inch BHS
210-0458-00				2	NUT, keps, 8-32 x 11/32 inch	
210-0804-00				2	WASHER, 8S x 3/8 inch	
-----				-	Mounting Hardware For Trace Rotator Coil:	
211-0507-00		100	1559	3	SCREW, 6-32 x 5/16 inch BHS	
211-0596-00		1560		3	SCREW, 8-32 x 3/8 inch THS	
210-0811-00		X1560		3	WASHER, fiber, #6	
210-0803-00		X1560		3	WASHER, 6L x 3/8 inch	
210-0457-00				3	NUT, keps, 6-32 x 5/16 inch	
80	337-0620-00			1	SHIELD, CRT	
	-----			-	Mounting Hardware: (not included)	
81	211-0504-00			4	SCREW, 6-32 x 1/4 inch BHS	
	252-0564-00			FT	POLYETHYLENE, extruded channel, cushion (8 5/8)	

Parts List—Type 547

EXPLODED VIEW (Cont'd)

REF. NO.	PART NO.	SERIAL/ MODEL NO.		QTY.	DESCRIPTION
		EFF.	DISC.		
82	354-0215-00			1	RING, CRT clamping, assembly
	- - - - -			-	Consisting Of:
	354-0211-00			1	RING, clamping
	211-0560-00			1	SCREW, 6-32 x 1 inch RHS
	210-0407-00			1	NUT, hex, 6-32 x 1/4 inch
83	124-0160-00			1	STRIP, liner, CRT clamp
84	214-0207-00			1	NUT, adjusting, securing
	- - - - -			-	Mounting Hardware: (not included)
	211-0576-00			2	SCREW, 6-32 x 7/8 inch socket head
	210-0949-00			4	WASHER, 9/64 ID x 1/2 inch OD
85	343-0089-00	100	5209	10	CLAMP, cable, large
	343-0089-00	5210		9	CLAMP, cable, large
86	348-0051-00			2	GROMMET, 15/16 inch
87	136-0168-00			1	SOCKET, CRT, assembly
	- - - - -			-	Includes:
	136-0117-00			1	SOCKET, CRT, raw
	131-0178-00			8	CONNECTOR, cable end, CRT
	387-0393-00			1	PLATE, back, CRT socket
	- - - - -			-	Mounting Hardware: (not included)
	213-0086-00			2	SCREW, thread cutting, 2-32 x 7/16 inch PHS
88	348-0006-00			5	GROMMET, 3/4 inch
89	406-0994-00			1	BRACKET, CRT mounting
	- - - - -			-	Mounting Hardware: (not included)
	212-0004-00			1	SCREW, 8-32 x 5/16 inch BHS
	210-0804-00			2	WASHER, 8S x 3/8 inch
	210-0457-00			1	NUT, keps, 8-32 x 11/32 inch
90	406-0936-00			1	BRACKET, CRT
	- - - - -			-	Mounting Hardware: (not included)
	212-0004-00			5	SCREW, 8-32 x 5/16 inch BHS
	210-0804-00			2	WASHER, 8S x 3/8 inch
	210-0457-00			3	NUT, keps, 8-32 x 11/32 inch
91	358-0166-00			3	BUSHING, plastic, black
92	441-0477-00	100	12479	1	CHASSIS, sweep deck
	441-0477-01	12480		1	CHASSIS, sweep deck
	- - - - -			-	Mounting Hardware: (not included)
	212-0002-00			4	SCREW, 8-32 x 1/4 inch FHS
	212-0004-00			5	SCREW, 8-32 x 5/16 inch BHS
	210-0804-00			5	WASHER, 8S x 3/8 inch
93	131-0018-00			1	CONNECTOR, chassis mount, 16 contact, female
	- - - - -			-	Mounting Hardware: (not included)
	211-0016-00			2	SCREW, 4-40 x 5/8 inch RHS
	166-0107-00	100	3169	2	TUBE, spacing, 7/32 inch
	166-0030-00	3170		2	TUBE, spacing, 3/16 inch
	210-0004-00			2	LOCKWASHER, internal, #4
	210-0406-00			2	NUT, hex, 4-40 x 3/16 inch
94	441-0475-00			1	CHASSIS, high voltage
	- - - - -			-	Mounting Hardware: (not included)
	212-0002-00			2	SCREW, 8-32 x 1/4 inch FHS
	212-0004-00			2	SCREW, 8-32 x 5/16 inch BHS
	212-0008-00			1	SCREW, 8-32 x 1/2 inch BHS
	210-0804-00			3	WASHER, 8S x 3/8 inch
	210-0458-00			1	NUT, keps, 8-32 x 11/32 inch

EXPLODED VIEW (Cont'd)

REF. NO.	PART NO.	SERIAL/MODEL NO.		QTY.	DESCRIPTION
		EFF.	DISC.		
95	343-0013-00			1	CLAMP, cable, 3/8 inch
	- - - - -			-	Mounting Hardware: (not included)
	210-0458-00			1	NUT, keps, 8-32 x 1 1/32 inch
	210-0863-00			1	WASHER, "D" type, #10
	210-0804-00			1	WASHER, 8S x 3/8 inch
96	348-0055-00			5	GROMMET, plastic
97	136-0011-00			1	SOCKET, STM8
	- - - - -			-	Mounting Hardware: (not included)
	211-0538-00	X2630		2	SCREW, 6-32 x 5/16 inch FHS
	210-0407-00			2	NUT, hex, 6-32 x 1/4 inch
	210-0006-00			2	LOCKWASHER, internal, #6
98	343-0095-00			1	CLAMP, tube
	- - - - -			-	Mounting Hardware: (not included)
	211-0008-00			1	SCREW, 4-40 x 1/4 inch BHS
	210-0004-00			1	LOCKWASHER, internal, #4
	210-0406-00			1	NUT, hex, 4-40 x 3/16 inch
99	385-0129-00			1	ROD, nylon
	- - - - -			-	Mounting Hardware: (not included)
	213-0104-00			1	SCREW, thread forming, 6-32 x 3/8 inch THS
100	136-0095-00	100	1159	35	SOCKET, 4 pin transistor
	136-0182-00	1160		6	SOCKET, 4 pin transistor
	136-0181-00	1160	12479	29	SOCKET, 3 pin transistor
	136-0181-00	12480		27	SOCKET, 3 pin transistor
	136-0235-00	12480		2	SOCKET, 6 pin transistor
	- - - - -			-	Mounting Hardware For Each: (not incl w/socket)
	213-0113-00	100	1159	2	SCREW, thread forming, 2-36 x 5/16 inch PHS
	354-0234-00	1160		1	RING, locking, transistor socket
101	426-0121-00			1	HOLDER, toroid
	- - - - -			-	Mounting Hardware: (not included)
	361-0007-00			1	SPACER, nylon, .063 inch
102	131-0235-00			4	CONNECTOR, terminal
	- - - - -			-	Mounting Hardware For Each: (not included)
	358-0136-00			1	BUSHING, teflon
103	343-0003-00			1	CLAMP, cable, 1/4 inch
	- - - - -			-	Mounting Hardware: (not included)
	211-0507-00			1	SCREW, 6-32 x 5/16 inch BHS
	210-0863-00			1	WASHER, "D" type, #10
	210-0803-00			1	WASHER, 6L x 3/8 inch
104	385-0024-00			2	ROD, aluminum
	- - - - -			-	Mounting Hardware For Each: (not included)
	211-0507-00			1	SCREW, 6-32 x 5/16 inch BHS
	210-0202-00			1	LUG, solder, SE6
105	- - - - -			-	Mounting Hardware For Capacitor:
	213-0088-00			2	SCREW, thread forming, 4-40 x 1/4 inch PHS
106	- - - - -			-	Mounting Hardware For Each Coil:
	213-0088-00			1	SCREW, thread forming, 4-40 x 1/4 inch PHS
107	210-0201-00			22	LUG, solder, SE4
	- - - - -			-	Mounting Hardware For Each: (not included)
	213-0044-00			1	SCREW, thread forming, 5-32 x 3/16 inch PHS
108	136-0015-00			25	SOCKET, STM9G
	- - - - -			-	Mounting Hardware For Each: (not included)
	213-0044-00			2	SCREW, thread cutting, 4-40 x 1/4 inch PHS

EXPLODED VIEW (Cont'd)

REF. NO.	PART NO.	SERIAL/MODEL NO.		QTY.	DESCRIPTION
		EFF.	DISC.		
109	119-0030-00			1	DELAY LINE, assembly
	- - - - -			-	Includes:
	380-0049-00			1	HOUSING, delay line
	200-0482-00	100	4999	1	COVER, delay line housing
	200-0482-02	5000		1	COVER, delay line housing
	131-0271-00			1	CONNECTOR, right hand
	211-0011-00			1	SCREW, 4-40 x 5/16 inch BHS
	211-0513-00			1	SCREW, 6-32 x 5/8 inch BHS
	211-0517-00			4	SCREW, 6-32 x 1 inch BHS
	210-0201-00			1	LUG, solder, SE4
	210-0407-00			9	NUT, hex, 6-32 x 1/4 inch
	210-0406-00			1	NUT, hex, 4-40 x 1/4 inch
	- - - - -			-	Mounting Hardware: (not included)
	210-0457-00			4	NUT, keps, 6-32 x 5/16 inch
110	214-0317-00	100	11119	2	HEAT SINK, insulator disc
	214-1138-00	11120		2	HEAT SINK, transistor
	- - - - -			-	Mounting Hardware For Each: (not included)
111	352-0062-00			1	HOLDER, transistor heat sink
112	343-0097-00			1	CLAMP, transistor heat sink
	211-0008-00			2	SCREW, 4-40 x 1/4 inch BHS
	211-0012-00			2	SCREW, 4-40 x 3/8 inch BHS
	210-0406-00			4	NUT, hex, 4-40 x 3/16 inch
	210-0599-00			2	NUT, sleeve
	214-0368-00			1	SPRING, transistor heat sink holder
	210-0627-00			1	RIVET
113	670-0401-00	100	10729	1	ASSEMBLY, circuit board, upper vertical amplifier
	670-0401-01	10730		1	ASSEMBLY, circuit board, upper vertical amplifier
	- - - - -			-	Includes:
	388-0553-00	100	10729	1	BOARD, circuit
	388-0553-01	10730		1	BOARD, circuit
114	136-0150-00	100	1409	6	SOCKET, 3 pin transistor
	136-0183-00	1410		6	SOCKET, 3 pin transistor
115	343-0088-00			1	CLAMP, cable, small
	- - - - -			-	Mounting Hardware: (not included)
	211-0507-00			4	SCREW, 6-32 x 5/16 inch BHS
	210-0801-00			4	WASHER, 5S x 7/32 inch
116	129-0069-00			4	POST, capacitor tie
	- - - - -			-	Mounting Hardware For Each: (not included)
	361-0007-00			1	SPACER, nylon, .063 inch
117	441-0476-00			1	CHASSIS, output vertical amplifier
	- - - - -			-	Mounting Hardware: (not included)
	212-0004-00			2	SCREW, 8-32 x 5/16 inch BHS
	210-0804-00			2	WASHER, 8S x 3/8 inch
	210-0458-00			4	NUT, keps, 8-32 x 11/32 inch
118	131-0335-00			1	CONNECTOR, deflector lead, assembly, brown
	131-0336-00			1	CONNECTOR, deflector lead, assembly, blue
	175-0588-00			1	WIRE, CRT lead, .833 foot, striped orange, with connector
	175-0592-00			1	WIRE, CRT lead, .960 foot, striped green, with connector
	175-0595-00			1	WIRE, CRT lead, .960 foot, striped red, with connector
119	343-0088-00			3	CLAMP, cable, small
120	- - - - -			-	Mounting Hardware For Each Miniature Pot:
	210-0583-00			1	NUT, hex, 1/4-32 x 5/16 inch
	210-0940-00			1	WASHER, 1/4 ID x 3/8 inch OD
121	348-0004-00			7	GROMMET, 3/8 inch

EXPLODED VIEW (Cont'd)

REF. NO.	PART NO.	SERIAL/MODEL NO.		QTY.	DESCRIPTION
		EFF.	DISC.		
122	355-0043-00			4	STUD, graticule, replacement (not shown)
	- - - - -			-	Each Includes:
	212-0507-00			1	SCREW, 10-32 x 3/8 inch BHS
	210-0010-00			1	LOCKWASHER, internal #10
123	200-0257-00			1	COVER, capacitor
124	432-0047-00			1	BASE, small capacitor mounting
	- - - - -			-	Mounting Hardware: (not included)
	211-0588-00			2	SCREW, 6-32 x 3/4 inch HHS
	210-0006-00			2	LOCKWASHER, internal, #6
	210-0407-00			2	NUT, hex, 6-32 x 1/4 inch
	386-0252-00			1	PLATE, fiber, small capacitor
125	210-0204-00			11	LUG, solder, DE4
	- - - - -			-	Mounting Hardware For Each: (not included)
	213-0044-00			1	SCREW, thread cutting, 5-32 x 3/16 inch PHS
126	432-0048-00			3	BASE, large capacitor mounting
	- - - - -			-	Mounting Hardware For Each: (not included)
	211-0588-00			2	SCREW, 6-32 x 3/4 inch HHS
	210-0006-00			2	LOCKWASHER, internal, #6
	210-0407-00			2	NUT, hex, 6-32 x 1/4 inch
	386-0255-00			3	PLATE, metal, large capacitor
127	- - - - -			-	Mounting Hardware For Each 25 Watt Resistor:
	212-0037-00			1	SCREW, 8-32 x 1 3/4 inches Fil HS
	210-0008-00			1	LOCKWASHER, internal, #8
	210-0809-00	100	10689	1	WASHER, resistor centering
	210-0808-00	10690		1	WASHER, resistor centering
	210-0462-00			1	NUT, hex, resistor mounting
	212-0004-00			1	SCREW, 8-32 x 5/16 inch BHS
128	- - - - -			1	Mounting Hardware For Each 10 Watt Resistor:
	211-0553-00			1	SCREW, 6-32 x 1 1/2 inches RHS
	210-0601-00			1	EYELET
	210-0478-00			1	NUT, hex, resistor mounting
	211-0507-00			1	SCREW, 6-32 x 5/16 inch BHS
129	- - - - -			-	Mounting Hardware For Each 5 Watt Resistor:
	211-0544-00			1	SCREW, 6-32 x 3/4 inch THS
	210-0478-00			1	NUT, hex, resistor mounting
	211-0507-00			1	SCREW, 6-32 x 5/16 inch BHS
130	432-0047-00			1	BASE, small capacitor mounting
	- - - - -			-	Mounting Hardware: (not included)
	211-0514-00			2	SCREW, 6-32 x 3/4 inch BHS
	210-0006-00			2	LOCKWASHER, internal, #6
	210-0407-00			2	NUT, hex, 6-32 x 1/4 inch
	386-0253-00			1	PLATE, metal, small capacitor
131	348-0002-00			2	GROMMET, 1/4 inch
132	348-0005-00			5	GROMMET, 1/2 inch
133	380-0048-00			1	HOUSING, high voltage
	- - - - -			-	Mounting Hardware: (not included)
	211-0507-00			3	SCREW, 6-32 x 5/16 inch BHS
134	- - - - -			-	Mounting Hardware For High Voltage Transformer:
	211-0521-00			2	SCREW, 6-32 x 1 1/2 inches RHS
	210-0801-00			2	WASHER, 5S x 9/32 inch
	358-0228-00			2	BUSHING, insulator

EXPLODED VIEW (Cont'd)

REF. NO.	PART NO.	SERIAL/MODEL NO.		QTY.	DESCRIPTION
		EFF.	DISC.		
135	166-0319-00			2	SLEEVE, high voltage
136	337-0566-00			1	SHIELD, high voltage
	- - - - -			-	Mounting Hardware: (not included)
	211-0504-00			4	SCREW, 6-32 x 1/4 inch BHS
	211-0541-00			1	SCREW, 6-32 x 1/4 inch FHS phillips
137	210-0261-00			2	LUG, solder, high voltage
	- - - - -			-	Mounting Hardware: (not included)
	211-0587-00			1	SCREW, 6-32 x 7/32 inch HHS
138	200-0475-00			1	COVER, high voltage
	- - - - -			-	Mounting Hardware: (not included)
139	211-0521-00			2	SCREW, 6-32 x 1 1/2 inches RHS
	210-0801-00			2	WASHER, 5S x 9/32 inch
140	166-0357-00			1	SLEEVE, high voltage anode lead
141	392-0147-00			1	BOARD, high voltage, with ceramic strips
	- - - - -			-	Mounting Hardware: (not included)
	211-0507-00			1	SCREW, 6-32 x 5/16 inch BHS
142	210-0966-00			2	WASHER, insulating, rubber, 7/16 ID x 7/8 inch OD
143	384-0542-00			2	ROD, capacitor mounting
	- - - - -			-	Mounting Hardware For Each: (not included)
	211-0507-00			1	SCREW, 6-32 x 5/16 inch BHS
144	385-0170-00			1	ROD, spacer, nylon
	- - - - -			-	Mounting Hardware: (not included)
	213-0041-00			1	SCREW, thread cutting, 6-32 x 3/8 inch THS phillips
145	337-0570-00			1	SHIELD, horizontal preamplifier
	- - - - -			-	Mounting Hardware: (not included)
	211-0504-00			2	SCREW, 6-32 x 1/4 inch BHS
146	129-0072-00			1	POST, diode tie-off
	- - - - -			-	Includes:
	131-0309-00			1	CONNECTOR, terminal
	- - - - -			-	Mounting Hardware: (not included)
	361-0007-00			1	SPACER, nylon, .063 inch
147	136-0013-00			2	SOCKET, STM8
	- - - - -			-	Mounting Hardware For Each: (not included)
	210-0407-00			2	NUT, hex, 6-32 x 1/4 inch
	210-0006-00			2	LOCKWASHER, internal, #6
148	214-0435-00			2	HEAT SINK, transistor
149	- - - - -			-	Mounting Hardware For Each Miniature Pot:
	210-0471-00			1	NUT, hex, 1/4-32 x 5/16 inch x 1 1/32 inch
	210-0046-00			2	LOCKWASHER, internal, .261 inch ID x .400 OD
	358-0054-00			1	BUSHING, banana jack
150	337-0588-00			1	SHIELD, sweep generator
	- - - - -			-	Mounting Hardware: (not included)
	211-0504-00			2	SCREW, 6-32 x 1/4 inch BHS
151	136-0008-00			7	SOCKET, STM7G
	- - - - -			-	Mounting Hardware For Each: (not included)
	213-0044-00			2	SCREW, thread cutting, 5-32 x 3/16 inch PHS phillips
152	- - - - -			-	Mounting Hardware For Each Pot:
	210-0444-00			1	NUT, hex, 3/8-32 x 1/2 inch
	210-0840-00			1	WASHER, .390 ID x 9/16 inch OD
	210-0012-00			1	LOCKWASHER, internal, 3/8 x 1/2 inch
	210-0207-00			1	LUG, solder, 3/8 inch
153	348-0031-00			14	GROMMET, poly snap-in
154	385-0134-00			3	ROD, delrin
	- - - - -			-	Mounting Hardware For Each: (not included)
	213-0104-00			1	SCREW, thread forming, 6-32 x 3/8 inch THS
155	432-0047-00			1	BASE, small capacitor mounting
	- - - - -			-	Mounting Hardware: (not included)
	211-0588-00			2	SCREW, 6-32 x 3/4 inch HHS
	210-0006-00			2	LOCKWASHER, internal, #6
	210-0407-00			2	NUT, hex, 6-32 x 1/4 inch
	386-0253-00			1	PLATE, metal, small capacitor

EXPLODED VIEW (Cont'd)

REF. NO.	PART NO.	SERIAL/MODEL NO.		QTY.	DESCRIPTION
		EFF.	DISC.		
156	384-0613-00			1	ROD, anchor Includes:
157	134-0033-00			2	PLUG, banana, male, push in type
158	214-0370-00			1	PIN, locating
				-	Mounting Hardware: (not included)
	212-0004-00			2	SCREW, 8-32 x 5/16 inch BHS
	210-0804-00			2	WASHER, 8S x 3/8 inch
159	337-0008-00			1	SHIELD, tube
160	376-0007-00			1	COUPLING Includes:
				2	SCREW, set, 8-32 x 1/8 inch HSS
161	262-0602-00			1	SWITCH, single sweep Includes:
				1	SWITCH, unwired
162	260-0496-00			1	SWITCH, reset, push Mounting Hardware: (not included)
	211-0034-00			2	SCREW, 2-56 x 1/2 inch RHS
	210-0850-00			2	WASHER, #2 flat
	210-0001-00			2	LOCKWASHER, internal, #2
	210-0405-00			2	NUT, hex, 2-56 x 3/16 inch Mounting Hardware: (not included)
	210-0586-00			2	NUT, keps, 4-40 x 1/4 inch
163	343-0005-00			1	CLAMP, cable, 7/16 inch Mounting Hardware: (not included)
	210-0457-00			1	NUT, keps, 6-32 x 5/16 inch
164	210-0863-00			1	WASHER, "D" type, #10
	385-0170-00			1	ROD, spacer, nylon Mounting Hardware: (not included)
	213-0068-00			1	SCREW, thread cutting, 6-32 x 5/16 inch FHS
165	387-0756-00	100	4389	1	PLATE, cabinet, bottom
	386-1093-00	4390	12799	1	PLATE, cabinet, bottom
	386-1093-03	12800		1	PLATE, cabinet, bottom Includes:
	214-0361-00			4	LATCH, quarter turn, assembly Each Consisting Of:
				1	PIN, securing, index
	214-0400-00			1	BUSHING, latch bearing
	358-0218-00			1	PLATE, latch index
	387-0871-00			1	PLATE, latch locking
	387-0804-00			1	SPRING, latch
	214-0359-00	100	6929	1	NUT, push-on
	220-0486-00	6930		1	ANGLE, rail, bottom
166	122-0108-00	100	6729	2	ANGLE, rail, bottom Mounting Hardware For Each: (not included)
	122-0108-02	6730		2	SCREW, 8-32 x 3/8 inch THS
	212-0039-00			4	NUT, keps, 8-32 x 1 1/32 inch
	210-0458-00			4	FOOT, rubber (not shown) Mounting Hardware: (not included)
	348-0052-00	X2020		4	SCREW, 8-32 x 1 inch, Fil HS
	212-0071-00	X2020	8149	2	SCREW, 8-32 x 0.875 inch, Fil HS
167	212-0090-00	8150		2	PLATE, vertical bulkhead Mounting Hardware: (not included)
	387-0759-00			1	SCREW, 8-32 x 3/8 inch THS
				4	NUT, keps, 8-32 x 1 1/32 inch
	212-0040-00			4	SCREW, 8-32 x 1/4 inch BHS
	210-0458-00			3	SCREW, 8-32 x 5/16 inch BHS
168	212-0001-00			2	CHASSIS, power Mounting Hardware: (not included)
	212-0004-00			1	SCREW, 8-32 x 3/8 inch THS
	441-0478-00			5	NUT, keps, 8-32 x 1 1/32 inch
				5	SCREW, 8-32 x 1/4 inch BHS
	212-0040-00			7	
	210-0458-00				
	212-0001-00				

Parts List—Type 547

EXPLODED VIEW (Cont'd)

REF. NO.	PART NO.	SERIAL/MODEL NO.		QTY.	DESCRIPTION
		EFF.	DISC.		
169	210-0804-00			7	WASHER, 8S x 3/8 inch
	337-0574-00			1	SHIELD, upper calibrator switch
	- - - - -			-	Mounting Hardware: (not included)
	211-0504-00			1	SCREW, 6-32 x 1/4 inch BHS
	210-0803-00			1	WASHER, 6L x 3/8 inch
	210-0457-00			1	NUT, keps, 6-32 x 5/16 inch
170	136-0022-00			1	SOCKET, STM9, shielded
	- - - - -			-	Mounting Hardware: (not included)
	213-0044-00			2	SCREW, thread cutting, 5-32 x 3/16 inch PHS
171	- - - - -			-	Mounting Hardware For Thermal Cutout:
	213-0044-00			2	SCREW, thread cutting, 5-32 x 3/16 inch PHS
172	406-0023-00			2	BRACKET, pot
	- - - - -			-	Mounting Hardware For Each: (not included)
	211-0507-00			2	SCREW, 6-32 x 5/16 inch BHS
	210-0006-00			2	LOCKWASHER, internal, #6
	210-0407-00			2	NUT, hex, 3/8-32 x 1/2 x 5/8 inch long
173	- - - - -			-	Mounting Hardware For Pot:
	210-0444-00			1	NUT, hex, 3/8-32 x 1/2 x 5/8 inch
	210-0840-00			1	WASHER, .390 ID x 9/16 inch OD
	210-0012-00			1	LOCKWASHER, internal, 3/8 x 1/2 inch
174	348-0003-00			5	GROMMET, 5/16 inch
175	210-0259-00			1	LUG, solder, #2
	- - - - -			-	Mounting Hardware: (not included)
176	213-0055-00			1	SCREW, thread cutting, 2-32 x 3/16 inch PHS
	441-0474-00	100	12479	1	CHASSIS, delayed sweep
	441-0474-01	12480		1	CHASSIS, delayed sweep
	- - - - -			-	Includes:
177	213-0172-00			2	THUMBSCREW, 6-32 x 0.812 inch
	354-0311-00	100	7529X	2	RING, rubber, 0.078 inch ID
178	131-0269-00			2	CONNECTOR, receptacle
179	358-0214-00			2	BUSHING, insulator
	- - - - -			-	Mounting Hardware: (not included)
	212-0008-00			3	SCREW, 8-32 x 1/2 inch BHS
180	210-0255-00			1	LUG, solder, pot
181	381-0215-00			1	BAR, stop
	- - - - -			-	Mounting Hardware: (not included)
182	212-0008-00			1	SCREW, 8-32 x 1/2 inch BHS
	387-0762-00	100	12799	1	PLATE, cabinet, right side
	387-0762-04	12800		1	PLATE, cabinet, right side
	- - - - -			-	Includes:
	214-0361-00			2	LATCH, quarter turn, assembly
	- - - - -			-	Each Consisting Of:
	214-0400-00			1	PIN, securing, index
	358-0218-00			1	BUSHING, latch bearing
	387-0871-00			1	PLATE, latch index
	387-0804-00			1	PLATE, latch locking
	214-0359-00	100	6929	1	SPRING, latch
	220-0486-00	6930		1	NUT, push-on
183	384-0614-00			1	ROD, chassis hinge
	- - - - -			-	Mounting Hardware: (not included)
184	361-0052-00	100	174	1	SPACER, hinge pin
	358-0237-00	175		1	BUSHING, hinge rod
	212-0010-00			1	SCREW, 8-32 x 5/8 inch BHS
185	358-0042-00	100	174	1	BUSHING, nylon
	361-0052-00	175		1	SPACER, hinge pin
186	343-0003-00			1	CLAMP, cable, 1/4 inch
	- - - - -			-	Mounting Hardware: (not included)
	212-0008-00			1	SCREW, 8-32 x 5/8 inch BHS
	210-0863-00			1	WASHER, "D" type, #10
187	406-0928-00	100	6729	1	BRACKET, transformer
	406-0928-02	6730		1	BRACKET, transformer

EXPLODED VIEW (Cont'd)

REF. NO.	PART NO.	SERIAL/MODEL NO.		QTY.	DESCRIPTION
		EFF.	DISC.		
188	- - - - -			-	Mounting Hardware: (not included)
	210-0564-00			2	NUT, hex, 10-32 x 3/8 inch
	210-0010-00			2	LOCKWASHER, internal, #10
	381-0221-00			2	BAR, transformer support
	- - - - -			-	Mounting Hardware For Each: (not included)
	212-0033-00			2	SCREW, 8-32 x 3/4 inch BHS
	210-0458-00			2	NUT, keps, 8-32 x 1 1/32 inch
	212-0509-00	100	6729	1	SCREW, 10-32 x 5/8 inch BHS
	212-0559-00	6730		1	SCREW, 10-32 x 5/8 inch, 100° csk, FHS
	212-0534-00			1	SCREW, 10-32 x 1 inch BHS
189	210-0010-00	100	6729	2	LOCKWASHER, internal, #10
	210-0010-00	6730		1	LOCKWASHER, internal, #10
	348-0012-00			1	GROMMET, 5/8 inch
	190 - - - - -			-	Mounting Hardware For Transformer:
	212-0524-00			4	SCREW, 10-32 x 3 1/4 inches HHS
	210-0812-00			4	WASHER, fiber, #10
	210-0010-00			4	LOCKWASHER, internal, #10
	210-0564-00			2	NUT, hex, 10-32 x 3/8 inch
	384-0612-00			2	ROD, transformer standoff
	202-0102-00			1	CAN, relay cover
191	- - - - -			-	Mounting Hardware: (not included)
	210-0457-00			2	NUT, keps, 6-32 x 5/16 inch
	426-0193-00			1	MOUNT, fan motor
	- - - - -			-	Mounting Hardware: (not included)
	212-0039-00			4	SCREW, 8-32 x 3/8 inch THS
	194 147-0026-00			1	MOTOR, fan
	- - - - -			-	Mounting Hardware: (not included)
	210-0458-00			4	NUT, keps, 8-32 x 1 1/32 inch
	195 214-0210-00			1	SPOOL, solder, assembly
	- - - - -			-	Includes:
214-0209-00			1	SPOOL, solder	
196	- - - - -			-	Mounting Hardware: (not included)
	361-0007-00			1	SPACER, nylon, .063 inch
	369-0007-00			1	FAN, 7 inch
	200-0260-00			1	COVER, large capacitor
	197 200-0259-00			1	COVER, large capacitor
	198 432-0048-00			2	BASE, large capacitor mounting
	- - - - -			-	Mounting Hardware For Each: (not included)
	211-0588-00			2	SCREW, 6-32 x 3/4 inch HHS
	210-0006-00			2	LOCKWASHER, internal, #6
	210-0407-00			2	NUT, hex, 6-32 x 1/4 inch
200	386-0254-00			2	PLATE, fiber, large capacitor
	387-0758-00	100	7979	1	PLATE, rear subpanel
	387-0758-02	7980		1	PLATE, rear subpanel
	- - - - -			-	Includes:
	354-0056-00			1	RING, ornamental
	387-0766-00	100	7979	1	PLATE, rear overlay
	387-0766-01	7980		1	PLATE, rear overlay
	- - - - -			-	Mounting Hardware: (not included)
	213-0104-00			4	SCREW, thread forming, 6-32 x 3/8 inch PHS
	202 334-0904-00	100	7979X	1	TAG, voltage rating
203	- - - - -			-	Mounting Hardware: (not included)
	213-0088-00	100	7979X	2	SCREW, thread forming, 4-40 x 1/4 inch PHS
	- - - - -			-	Mounting Hardware For 20 Watt Resistor
	212-0037-00			1	SCREW, 8-32 x 1 3/4 inches Fil HS
	210-0808-00			1	WASHER, resistor centering
	210-0462-00			1	NUT, hex, resistor mounting
	212-0004-00			1	SCREW, 8-32 x 5/16 inch BHS
	204 352-0002-00	100	7979X	1	HOLDER, fuse, assembly
	- - - - -			-	Consisting Of:
	352-0010-00			1	HOLDER, fuse

EXPLODED VIEW (Cont'd)

REF. NO.	PART NO.	SERIAL/MODEL NO.		QTY.	DESCRIPTION
		EFF.	DISC.		
	200-0015-00			1	CAP, fuse
	210-0873-00			-	WASHER, rubber, 1/2 ID x 1 1/16 inch OD
	-----			-	NUT, fuse holder
	204-0279-00	X7980		1	BODY, line voltage selector (not shown)
	-----			-	Mounting Hardware: (not included)
	210-0006-00			2	LOCKWASHER, internal, #6
	210-0407-00			2	NUT, hex., 6-32 x 1/4 inch
	200-0704-00	X7980		1	COVER, line voltage selector (not shown)
	-----			-	consisting of:
	352-0102-00			2	HOLDER, plastic, fuse
	-----			-	Mounting Hardware For Each: (not included)
	213-0088-00			1	SCREW, thread forming, #4 x 1/4 inch, PHS
	179-1214-00	X7980		1	CABLE HARNESS, line voltage selector (not shown)
205	131-0150-00	100	6589	1	CONNECTOR, chassis mounted, motor base
	131-0150-01	6590	7209	1	CONNECTOR, chassis mounted, motor base
	131-0572-00	7210	7979X	1	CONNECTOR, chassis mounted, motor base
	-----			-	consisting of:
	129-0041-00	100	6589	1	POST, ground
	129-0041-01	6590	7209	1	POST, ground
	200-0185-00	100	6589	1	COVER
	200-0185-01	6590	7209	1	COVER
	204-0335-00	7210	7979X	1	BODY—CONTACT ASSEMBLY
	210-0003-00	100	6589X	2	LOCKWASHER, internal, #4
	210-0551-00	100	6589X	2	NUT, hex., 4-40 x 1/4 inch
	211-0132-00	X6590	7209	1	SCREW, sems, 4-40 x 1/2 inch, PHS
	211-0534-00	7210	7979X	1	SCREW, sems, 6-32 x 5/16 inch, PHS
	211-0015-00	100	6589	1	SCREW, 4-40 x 1/2 inch, RHS
	213-0088-00	6590	7209	1	SCREW, thread forming, #4 x 1/4 inch, PHS
	213-0146-00	7210	7979X	1	SCREW, thread forming, #6 x 0.313 inch, PHS
	214-0078-00	100	7979X	2	PIN, connecting
	377-0041-00	100	6589	1	INSERT
	377-0051-00	6590	7209	1	INSERT
	214-1016-00	7210	7979X	1	INSULATOR
	-----			-	Mounting Hardware: (not included)
	213-0104-00			2	SCREW, thread forming, 6-32 x 3/8 inch THS
	161-0033-01	X7980		1	ASSEMBLY, power cord
	-----			-	consisting of:
	161-0033-00			1	CORD, power
	358-0161-00			1	BUSHING, strain relief
	103-0071-01			1	ADAPTER, strain relief
	-----			-	Mounting Hardware: (not included)
	211-0537-00			2	SCREW, 6-32 x 3/8 inch, THS
	210-0457-00			2	NUT, keps, 6-32 x 5/16 inch
	210-0202-00			1	LUG, solder
	-----			-	Mounting Hardware: (not included)
	213-0146-00			1	SCREW, thread forming, #6 x 0.313 inch, PHS
	124-0207-00			1	TERMINAL STRIP, ceramic, w/2 notches
	-----			-	Mounting Hardware: (not included)
	358-0324-00			2	BUSHING, sleeve
	213-0166-00			2	SCREW, thread forming, #6 x 0.75 inch, PHS
	-----			-	Mounting Hardware: (not included)
	211-0542-00			2	SCREW, 6-32 x 5/16 inch, THS
206	378-0023-00			1	FILTER, air, foam
207	378-0762-00			1	SCREEN, filter
	-----			-	Mounting Hardware: (not included)
	213-0104-00			4	SCREW, thread forming, 6-32 x 3/8 inch THS
	214-1000-00	X7980		4	CORNER, filter
208	406-0910-00			1	BRACKET, shunt resistor
	-----			-	Mounting Hardware: (not included)
	211-0537-00			2	SCREW, 6-32 x 3/8 inch THS

EXPLODED VIEW (Cont'd)

REF. NO.	PART NO.	SERIAL/MODEL NO.		QTY.	DESCRIPTION
		EFF.	DISC.		
209	122-0019-00			1	ANGLE, frame, top right
	- - - - -			-	Mounting Hardware: (not included)
	211-0559-00			4	SCREW, 6-32 x 3/8 inch FHS
	210-0457-00			4	NUT, keps, 6-32 x 5/16 inch
210	380-0018-00			1	HOUSING, air filter
	- - - - -			-	Mounting Hardware: (not included)
	212-0031-00			2	SCREW, 8-32 x 1 1/4 inches RHS
	210-0458-00			2	NUT, keps, 8-32 x 1 1/32 inch
	210-0402-00			2	NUT, cap, hex, 8-32 x 5/16 inch
211	131-0206-00			1	CONNECTOR, receptacle
	- - - - -			-	Mounting Hardware: (not included)
	210-0559-00			1	NUT, hex, 7/16-28 x 9/16 inch
	210-0021-00			1	LOCKWASHER, internal
	210-0260-00			1	LUG, solder
212	260-0209-00			1	SWITCH, CRT CATHODE SELECTOR, toggle
	- - - - -			-	Mounting Hardware: (not included)
	210-0473-00			1	NUT, switch, 15/32-32 x 5/64 inch
	210-0902-00			1	WASHER, .470 ID x 2 1/32 inch OD
	210-0414-00			1	NUT, hex, 15/32-32 x 9/16 inch
213	387-0853-00			1	PLATE, binding post mounting
214	129-0064-00			1	POST, binding
	- - - - -			-	Mounting Hardware: (not included)
	210-0457-00			1	NUT, keps, 6-32 x 5/16 inch
215	346-0027-00			1	STRAP, ground
216	381-0217-00			1	BAR, top support, with handle
	- - - - -			-	Includes:
217	344-0098-00			4	CLIP, handle
	212-0566-00	100	4419	4	SCREW, 10-32 x 5/16 inch RHS
	212-0507-00	4420		4	SCREW, 10-32 x 3/8 inch PHS
	210-0010-00	X4420		4	LOCKWASHER, internal, #10
218	367-0037-00			2	HANDLE
	- - - - -			-	Mounting Hardware: (not included)
219	381-0073-00			2	BAR, retaining
	212-0039-00			4	SCREW, 8-32 x 3/8 inch THS
220	- - - - -			-	Mounting Hardware For Relay:
	211-0503-00			2	SCREW, 6-32 x 3/16 inch BHS
221	441-0473-00	100	2339	1	CHASSIS, vertical amplifier
	441-0473-01	2340		1	CHASSIS, vertical amplifier
	- - - - -			-	Mounting Hardware: (not included)
	212-0004-00			3	SCREW, 8-32 x 5/16 inch BHS
	210-0804-00			3	WASHER, 8S x 3/8 inch
	212-0040-00			1	SCREW, 8-32 x 5/16 inch PHS
	210-0458-00			1	NUT, keps, 8-32 x 1 1/32 inch
222	337-0589-00			1	SHIELD, sweep amplifier
	- - - - -			-	Mounting Hardware: (not included)
	211-0504-00			2	SCREW, 6-32 x 1/4 inch PHS
223	366-0220-00			1	KNOB, TRACE SEPARATION, small charcoal
	- - - - -			-	Includes:
	213-0004-00			1	SCREW, set, 6-32 x 3/16 inch HSS
224	348-0063-00			1	GROMMET, plastic, 1/2 inch
225	- - - - -	X2340		1	TRANSISTOR
	- - - - -			-	Mounting hardware: (not included w/transistor)
	386-0143-00			1	PLATE, mica insulator
	211-0510-00			2	SCREW, 6-32 x 3/8 inch, PHS
	210-0983-00	2340	4419	2	WASHER, shoulder
	210-0935-00	4420		2	WASHER, fiber, 0.140 ID x 0.375 inch OD
	210-0802-00			2	WASHER, 6S x 5/16 inch
	210-0006-00	2340	3269X	1	LOCKWASHER, internal, #6
	210-0202-00			1	LUG, solder, SE 6
	210-0407-00	2340	3269	2	NUT, hex, 6-32 x 1/4 inch
	210-0457-00	3270		2	NUT, keps, 6-32 x 5/16 inch

CERAMIC STRIP & CABLE

POWER CHASSIS

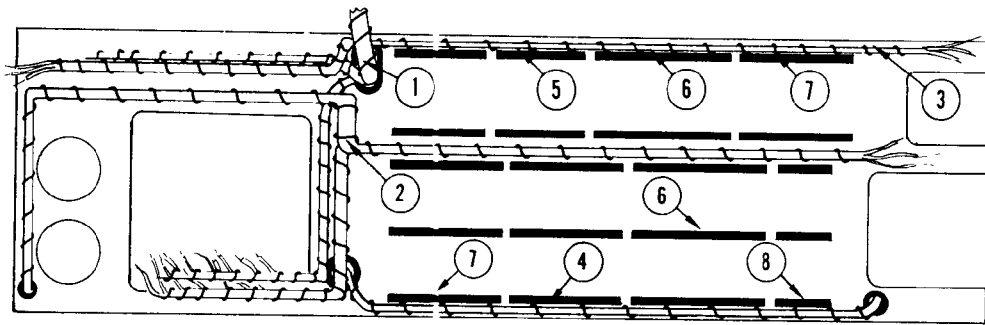

SWEEP "A" CHASSIS

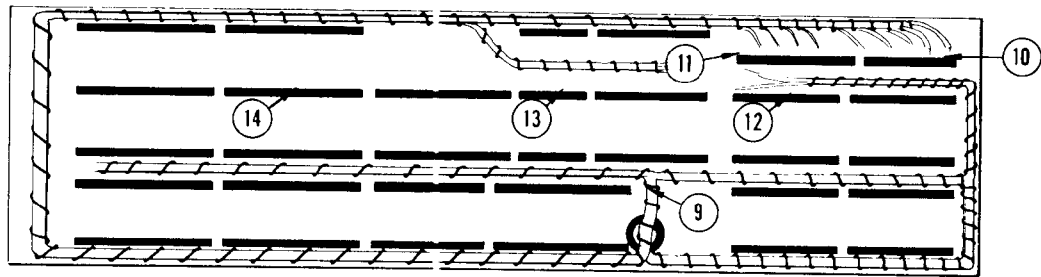

HIGH VOLTAGE CHASSIS

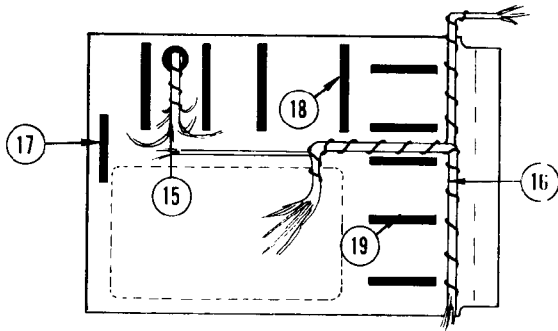

SWEEP "B" CHASSIS

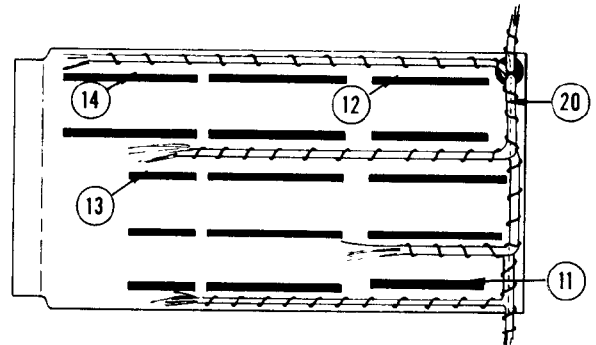

LOWER VERTICAL AMPLIFIER CHASSIS

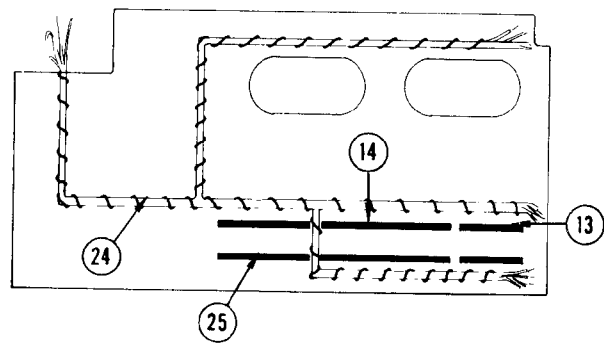

HIGH VOLTAGE

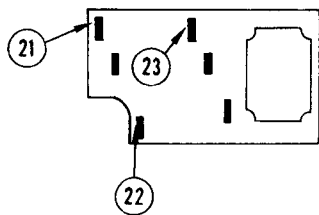

CABLE HARNESS AND CERAMIC STRIP DETAIL

REF. NO.	PART NO.	SERIAL/MODEL NO.		QTY.	DESCRIPTION
		EFF.	DISC.		
1	179-0771-00	100	7979	1	CABLE HARNESS, inter-connecting
	179-0771-01	7980		1	CABLE HARNESS, inter-connecting
2	179-0761-00	100	7979	1	CABLE HARNESS, power
	179-0761-01	7980		1	CABLE HARNESS, power
3	179-0765-00	100	7979	1	CABLE HARNESS, 110 volt
	179-0765-01	7980		1	CABLE HARNESS, 110 volt
4	179-0764-00	100	7329	1	CABLE HARNESS, 150 volt adjustment
	179-0764-01	7330		1	CABLE HARNESS, 150 volt adjustment
5	124-0089-00			5	STRIP, ceramic, $\frac{3}{4}$ inch x 7 notches
	355-0046-00			-	Each Includes:
				2	STUD, nylon
				-	Mounting Hardware For Each: (not included)
6	361-0009-00			2	SPACER, nylon, .313 inch
	124-0091-00			6	STRIP, ceramic, $\frac{3}{4}$ inch x 11 notches
	355-0046-00			-	Each Includes:
				2	STUD, nylon
				-	Mounting Hardware For Each: (not included)
	361-0009-00			2	SPACER, nylon, .313 inch
7	124-0090-00			8	STRIP, ceramic, $\frac{3}{4}$ inch x 9 notches
	355-0046-00			-	Each Includes:
				2	STUD, nylon
				-	Mounting Hardware For Each: (not included)
	361-0009-00			2	SPACER, nylon, .313 inch
8	124-0088-00			3	STRIP, ceramic, $\frac{3}{4}$ inch x 4 notches
	355-0046-00			-	Each Includes:
				2	STUD, nylon
				-	Mounting Hardware For Each: (not included)
	361-0009-00			2	SPACER, nylon, .313 inch
9	179-0762-00			1	CABLE HARNESS, "A" sweep
10	124-0094-00			1	STRIP, ceramic, $\frac{7}{16}$ inch x 7 notches
	355-0046-00			-	Includes:
				2	STUD, nylon
				-	Mounting Hardware For Each: (not included)
	361-0009-00			2	SPACER, nylon, .313 inch
11	124-0095-00			2	STRIP, ceramic, $\frac{7}{16}$ inch x 9 notches
	355-0046-00			-	Each Includes:
				2	STUD, nylon
				-	Mounting Hardware For Each: (not included)
	361-0009-00			2	SPACER, nylon, .313 inch
12	124-0155-00			15	STRIP, ceramic, $\frac{7}{16}$ inch x 16 notches
	355-0082-00			-	Each Includes:
				2	STUD, nylon
				-	Mounting Hardware For Each: (not included)
	361-0039-00			2	SPACER, nylon, $\frac{11}{32}$ inch
13	124-0157-00			8	STRIP, ceramic, $\frac{7}{16}$ inch x 3 notches
	355-0082-00			-	Each Includes:
				2	STUD, nylon
				-	Mounting Hardware For Each: (not included)
	361-0039-00			2	SPACER, nylon, $\frac{11}{32}$ inch
14	124-0154-00			25	STRIP, ceramic, $\frac{7}{16}$ inch x 20 notches
	355-0082-00			-	Each Includes:
				2	STUD, nylon
				-	Mounting Hardware For Each: (not included)
	361-0039-00			2	SPACER, nylon, $\frac{11}{32}$ inch
15	179-0769-00			1	CABLE HARNESS, focus and intensity
16	179-0767-00			1	CABLE HARNESS, high voltage
17	124-0120-00			1	STRIP, ceramic, $\frac{7}{16}$ inch x 4 notches
	355-0046-00			-	Includes:
				2	STUD, nylon
				-	Mounting Hardware For Each: (not included)
	361-0008-00			2	SPACER, nylon, .188 inch

CABLE HARNESS AND CERAMIC STRIP DETAIL (Cont'd)

REF. NO.	PART NO.	SERIAL/MODEL NO.		QTY.	DESCRIPTION
		EFF.	DISC.		
18	124-0089-00			4	STRIP, ceramic, 3/4 inch x 7 notches
	- - - - -			-	Each Includes:
	355-0046-00			2	STUD, nylon
	- - - - -			-	Mounting Hardware For Each: (not included)
	361-0008-00			2	SPACER, nylon, .188 inch
19	124-0093-00			5	STRIP, ceramic, 7/16 inch x 5 notches
	- - - - -			-	Each Includes:
	355-0046-00			2	STUD, nylon
	- - - - -			-	Mounting Hardware For Each: (not included)
	361-0009-00			2	SPACER, nylon, .313 inch
20	179-0763-00	100	6739	1	CABLE HARNESS, "B" sweep
	179-0763-01	6740		1	CABLE HARNESS, "B" sweep
21	124-0164-00			2	STRIP, ceramic, 4 notches
22	124-0163-00			4	STRIP, ceramic, 2 notches
23	124-0162-00			1	STRIP, ceramic, 7/16 inch x 4 notches
	- - - - -			-	Includes:
	355-0046-00			1	STUD, nylon
	- - - - -			-	Mounting Hardware For Each: (not included)
	361-0007-00			1	SPACER, nylon, .063 inch
24	179-0770-00	100	2339	1	CABLE HARNESS, lower vertical amplifier
	179-0770-01	2340		1	CABLE HARNESS, lower vertical amplifier
25	124-0156-00			2	STRIP, ceramic, 7/16 inch x 13 notches
	- - - - -			-	Each Includes:
	355-0082-00			2	STUD, nylon
	- - - - -			-	Mounting Hardware For Each: (not included)
	361-0039-00			2	STUD, nylon, 1/32 inch

STANDARD ACCESSORIES

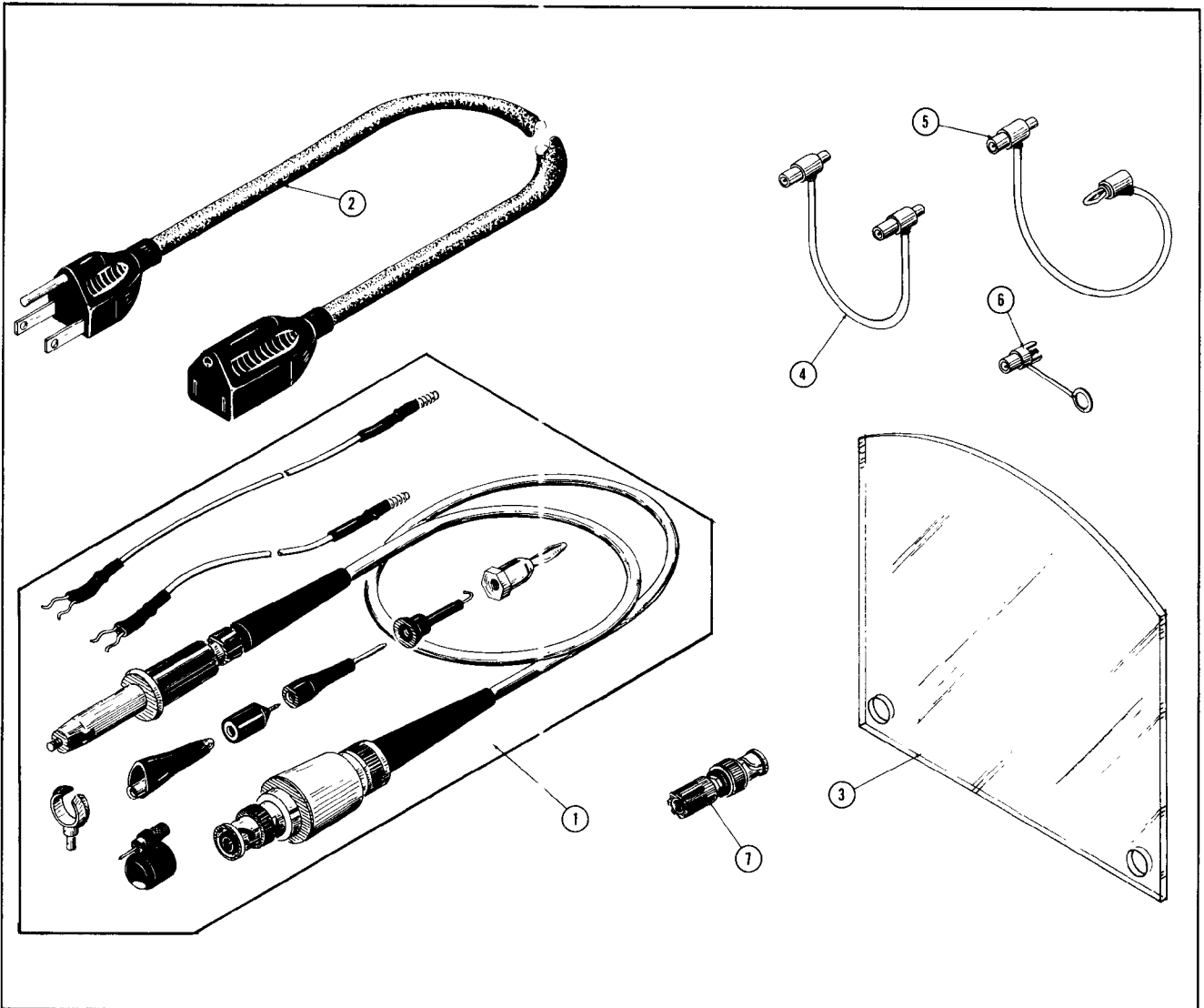

REF. NO.	PART NO.	SERIAL/MODEL NO.		QTY.	DESCRIPTION
		EFF.	DISC.		
1	010-0129-00			2	PROBE, package, P6008
2	161-0010-00	100	6269	1	CORD, power
	161-0010-03	6270	7979X	1	CORD, power
3	387-0918-00			1	PLATE, protector
	378-0545-00	100	2589	1	FILTER, light, smoke gray (installed)
	378-0567-00	2590		1	FILTER, light, smoke gray (installed)
4	012-0031-00	100	1589	2	CORD, patch
	012-0087-00	1590		3	CORD, patch
5	012-0091-00	X1590		2	CORD, patch
6	012-0092-00	X1590		1	JACK, BNC—post
7	103-0033-00		1589X	3	ADAPTER, BNC to binding post
	070-0398-00			1	MANUAL, instruction (not shown)

ELECTRICAL PARTS

Values are fixed unless marked Variable.

Ckt. No.	Tektronix Part No.	Description	S/N Range
Bulbs			
B89	150-030	Neon, NE-2V	READY
B90W	150-030	Neon, NE-2V	UNCALIBRATED
B94	150-027	Neon, NE-23	
B289	150-030	Neon, NE-2V	READY
B290W	150-030	Neon, NE-2V	UNCALIBRATED
B294	150-027	Neon, NE-23	
B550	150-030	Neon, NE-2V	MAG ON
B579	150-037	Neon, ST2-27S	
B583	150-027	Neon, NE-23	
B589	150-037	Neon, ST2-27S	
B602	150-001	Incandescent, #47	Pilot Light
B603	150-031	Incandescent, #44	Graticule Light
B604	150-031	Incandescent, #44	Graticule Light
B1184	150-030	Neon, NE-2V	
B1194	150-030	Neon, NE-2V	

Capacitors

Tolerance $\pm 20\%$ unless otherwise indicated.

Tolerance of all electrolytic capacitors as follows (with exceptions):

3V — 50V = -10% , $+250\%$ 51V — 350V = -10% , $+100\%$ 351V — 450V = -10% , $+50\%$

C1	283-001	0.005 μf	Cer	500 v	
C2	281-523	100 pf	Cer	350 v	
C4	283-002	0.01 μf	Cer	500 v	
C5	283-000	0.001 μf	Cer	500 v	
C6	281-512	27 pf	Cer	500 v	10%
C8	Use 283-057	0.1 μf	Cer	200 v	
C11	283-001	0.005 μf	Cer	500 v	
C12	281-523	100 pf	Cer	350 v	
C18	283-067	0.001 μf	Cer	200 v	10%
C41	281-523	100 pf	Cer	350 v	100-6739X
C43	281-525	470 pf	Cer	500 v	100-6739X
C49	283-006	0.02 μf	Cer	600 v	
C50	283-002	0.01 μf	Cer	500 v	
C51	283-002	0.01 μf	Cer	500 v	
C53	283-000	0.001 μf	Cer	500 v	
C56	281-576	11 pf	Cer	500 v	5% 100-6739
C56	281-0578-00	18 pf	Cer	500 v	5% 6740-up
C57	281-0578-00	18 pf	Cer	500 v	5% X6740-up
C67	283-026	0.2 μf	Cer	25 v	100-15049
C67	285-0835-00	0.22 μf	Plastic	100 v	2% 15050-up
C76	290-187	4.7 μf	EMT	35 v	100-6739
C76	290-0175-00	10 μf	EMT	35 v	6740-up
C78	283-003	0.01 μf	Cer	150 v	
C83	281-524	150 pf	Cer	500 v	
C85	281-519	47 pf	Cer	500 v	10%
C90A	281-007	3-12 pf	Cer	Var	
C90B	281-007	3-12 pf	Cer	Var	
C90C	281-010	4.5-25 pf	Cer	Var	
C90D	281-574	82 pf	Cer	500 v	10%

Parts List—Type 547

Capacitors (Cont'd)

Ckt. No.	Tektronix Part No.		Description			S/N Range			
C90E C90F C90G C90H C90J	*295-073	0.001 μ f 0.01 μ f 0.1 μ f 1 μ f 10 μ f	Timing Series			100-5309			
C90E C90F C90G C90H C90J		*295-0104-00		0.001 μ f 0.01 μ f 0.1 μ f 1 μ f 10 μ f	Timing Series			5310-up	
C90K				281-524		150 pf	Cer	500 v	
C92				283-001		0.005 μ f	Cer	500 v	
C94				281-578		18 pf	Cer	500 v	5%
C96	283-006		0.02 μ f	Cer		600 v			
C98	Use 281-604	2.2 pf	Cer	500 v	± 0.25 pf				
C99	281-007	3-12 pf	Cer						
C101	281-523	100 pf	Cer	350 v					
C103	283-000	0.001 μ f	Cer	500 v					
C128	281-550	120 pf	Cer	500 v	10%				
C130A	281-550	120 pf	Cer	500 v	10%				
C130B	285-543	0.0022 μ f	MT	400 v					
C130C	285-636	0.022 μ f	PTM	200 v					
C130D	285-633	0.22 μ f	PTM	100 v	10%				
C130E	285-576	1 μ f	PTM	100 v	10%				
C137	281-523	100 pf	Cer	350 v					
C144	283-002	0.01 μ f	Cer	500 v					
C146	281-512	27 pf	Cer	500 v	10%				
C166	281-543	270 pf	Cer	500 v	10%				
C170	281-605	200 pf	Cer	500 v					
C175	281-512	27 pf	Cer	500 v	10%				
C178	281-558	18 pf	Cer	500 v					
C186	281-012	7-45 pf	Cer						
C188	283-002	0.01 μ f	Cer	500 v					
C192	283-006	0.02 μ f	Cer	600 v					
C197	283-006	0.02 μ f	Cer	600 v					
C199	281-511	22 pf	Cer	500 v	10%				
C201	283-001	0.005 μ f	Cer	500 v					
C202	281-523	100 pf	Cer	350 v					
C204	283-002	0.01 μ f	Cer	500 v					
C205	283-000	0.001 μ f	Cer	500 v					
C206	281-512	27 pf	Cer	500 v	10%				
C211	283-001	0.005 μ f	Cer	500 v					
C212	281-523	100 pf	Cer	350 v					
C218	283-000	0.001 μ f	Cer	500 v					
C241	281-523	100 pf	Cer	350 v		100-6739X			
C243	281-525	470 pf	Cer	500 v		100-6739X			
C249	283-006	0.02 μ f	Cer	600 v					
C253	283-000	0.001 μ f	Cer	500 v					
C256	281-576	11 pf	Cer	500 v	5%	100-6739			
C256	281-0578-00	18 pf	Cer	500 v	5%	6740-up			
C257	281-0578-00	18 pf	Cer	500 v	5%	X6740-up			

Capacitors (Cont'd)

Ckt. No.	Tektronix Part No.		Description			S/N Range
C265	283-000	0.001 μ f	Cer		500 v	
C267	283-026	0.2 μ f	Cer		25 v	100-15049
C267	285-0835-00	0.22 μ f	Plastic		100 v	2% 15050-up
C276	290-187	4.7 μ f	EMT		35 v	100-6739
C276	290-0175-00	10 μ f	EMT		35 v	6740-up
C278	283-003	0.01 μ f	Cer		150 v	
C283	281-524	150 pf	Cer		500 v	
C290A	281-007	3-12 pf	Cer	Var		
C290B	281-007	3-12 pf	Cer	Var		
C290C	281-010	4.5-25 pf	Cer	Var		
C290D	281-574	82 pf	Cer		500 v	10%
C290E	*295-073	0.001 μ f		Timing Series		100-5309
C290F		0.01 μ f				
C290G		0.1 μ f				
C290H		1 μ f				
C290J		10 μ f				
C290E	*295-0104-00	0.001 μ f		Timing Series		5310-up
C290F		0.01 μ f				
C290G		0.1 μ f				
C290H		1 μ f				
C290J		10 μ f				
C292	283-001	0.005 μ f	Cer		500 v	
C294	281-528	82 pf	Cer		500 v	10%
C296	283-006	0.02 μ f	Cer		600 v	
C299	Use 281-010	4.5-25 pf	Cer	Var		
C301	281-519	47 pf	Cer		500 v	10%
C303	283-000	0.001 μ f	Cer		500 v	
C311	283-000	0.001 μ f	Cer		500 v	
C314	283-002	0.01 μ f	Cer		500 v	
C328	281-550	120 pf	Cer		500 v	10%
C329	281-519	47 pf	Cer		500 v	10%
C330A	281-550	120 pf	Cer		500 v	10%
C330B	285-543	0.0022 μ f	MT		400 v	
C330C	285-636	0.022 μ f	PTM		200 v	
C330D	285-633	0.22 μ f	PTM		100 v	10%
C330E	285-576	1 μ f	PTM		100 v	10%
C337	281-523	100 pf	Cer		350 v	
C344	283-002	0.01 μ f	Cer		500 v	
C346	281-512	27 pf	Cer		500 v	10%
C360	281-523	100 pf	Cer		350 v	
C365	281-543	270 pf	Cer		500 v	10%
C369	281-546	330 pf	Cer		500 v	10%
C370	281-605	200 pf	Cer		500 v	
C375	281-544	5.6 pf	Cer		500 v	10%
C380	281-536	1000 pf	Cer		500 v	10%
C382	283-006	0.02 μ f	Cer		600 v	X1880 up
C392	283-006	0.02 μ f	Cer		600 v	
C397	283-006	0.02 μ f	Cer		600 v	
C398	283-002	0.01 μ f	Cer		500 v	
C399	283-002	0.01 μ f	Cer		500 v	
C406	283-001	0.005 μ f	Cer		500 v	

Parts List—Type 547

Capacitors (Cont'd)

Ckt. No.	Tektronix Part No.		Description		S/N Range
C412	285-572	0.1 μ f	PTM		200 v
C424	283-000	0.001 μ f	Cer		500 v
C426	281-523	100 pf	Cer		350 v
C428	283-001	0.005 μ f	Cer		500 v
C436	283-002	0.01 μ f	Cer		500 v
C438	283-002	0.01 μ f	Cer		500 v
C439	283-001	0.005 μ f	Cer		500 v
C441	281-528	82 pf	Cer		500 v 10%
C446	283-000	0.001 μ f	Cer		500 v
C449	281-575	39 pf	Cer		500 v 1%
C454	281-512	27 pf	Cer		500 v 10%
C456	283-006	0.02 μ f	Cer		600 v
C459	281-575	39 pf	Cer		500 v 1%
C467	281-549	68 pf	Cer		500 v 10%
C475	283-004	0.02 μ f	Cer		150 v
C477	281-549	68 pf	Cer		500 v 10%
C503A	281-558	18 pf	Cer		500 v
C503C	281-012	7-45 pf	Cer	Var	
C503D	281-560	198 pf	Cer		500 v
C516	283-001	0.005 μ f	Cer		500 v
C524	281-010	4.5-25 pf	Cer	Var	
C525	281-557	1.8 pf	Cer		500 v
C538	281-549	68 pf	Cer		500 v 10%
C541	283-002	0.01 μ f	Cer		500 v
C544	281-549	68 pf	Cer		500 v 10%
C550	283-000	0.001 μ f	Cer		500 v
C557D	281-009	3-12 pf	Cer	Var	
C557F	281-013	8-50 pf	Cer	Var	
C557H	281-013	8-50 pf	Cer	Var	
C562	290-0214-00	10 μ f	EMT		250 v X5680-up
C572	281-022	8-50 pf	Cer	Var	
C574	283-001	0.005 μ f	Cer		500 v
C576	281-053	0.35-1.37 pf	Poly	Var	
C579	283-068	0.01 μ f	Cer		500 v
C582	281-022	8-50 pf	Cer	Var	
C584	283-001	0.005 μ f	Cer		500 v
C586	281-053	0.35-1.37 pf	Poly	Var	
C589	283-068	0.01 μ f	Cer		500 v
C591	281-036	3-12 pf	Cer	Var	
C592	283-002	0.01 μ f	Cer		500 v
C598	285-628	0.033 μ f	PTM		300 v
C599	283-000	0.001 μ f	Cer		500 v
C600	285-519	0.047 μ f	MT		400 v
C610	285-510	0.01 μ f	MT		400 v
C617	285-519	0.047 μ f	MT		400 v
C628	285-510	0.01 μ f	MT		400 v
C636	281-519	47 pf	Cer		500 v 10%

Capacitors (Cont'd)

Ckt. No.	Tektronix Part No.	Description	S/N Range
C640	283-022	0.02 μ f Cer	1400 v
C642A,B	Use 290-197	250 μ f x 40 μ f EMC	350 v/250 v
C650	285-510	0.01 μ f MT	400 v
C665	283-001	0.005 μ f Cer	500 v
C670	283-022	0.02 μ f Cer	1400 v
C671	Use 290-180	300 μ f EMC	250 v
C680	285-510	0.01 μ f MT	400 v
C688	285-510	0.01 μ f MT	400 v
C694	281-523	100 pf Cer	350 v
C701	Use 290-192	200 μ f EMC	400 v
C709A	Use 290-195	10 μ f	450 v
C709B		10 μ f	350 v
C709C		20 μ f	250 v
C710	285-511	0.01 μ f PTM	600 v
C730	Use 290-179	125 μ f EMC	250 v
C754	283-002	0.01 μ f Cer	500 v
C756	283-002	0.01 μ f Cer	500 v
C760	281-549	68 pf Cer	500 v
C765	281-505	12 pf Cer	500 v
C767	283-003	0.01 μ f Cer	150 v
C768	281-604	2.2 pf Cer	500 v
C769	283-006	0.02 μ f Cer	600 v
C770	283-002	0.01 μ f Cer	500 v
C771	Use 290-185	2 x 40 μ f EMC	250 v
C772	283-002	0.01 μ f Cer	500 v
C773A	Use 290-196	40 μ f	250 v
C773B		20 μ f	350 v
C773C		20 μ f	450 v
C774	283-002	0.01 μ f Cer	500 v
C775	283-002	0.01 μ f Cer	500 v
C777	283-002	0.01 μ f Cer	500 v
C802	Use 290-190	40 μ f EMC	400 v
C803	283-000	0.001 μ f Cer	500 v
C806	285-506	0.0047 μ f Cer	400 v
C808	285-502	0.001 μ f MT	1000 v
C820	283-082	0.01 μ f Cer	4000 v
C821	283-082	0.01 μ f Cer	4000 v
C822	281-525	470 pf Cer	500 v
C823	283-101	0.0047 μ f Cer	6000 v
C828	281-536	0.001 μ f Cer	500 v
C829	283-082	0.01 μ f Cer	4000 v
C830	283-082	0.01 μ f Cer	4000 v
C832	283-002	0.01 μ f Cer	500 v
C833	281-556	500 pf Cer	10000 v
C834	281-556	500 pf Cer	10000 v
C835	281-511	22 pf Cer	500 v
C836	283-096	500 pf Cer	20000 v
C841	283-006	0.02 μ f Cer	600 v
C842	283-082	0.01 μ f Cer	4000 v
C852	283-082	0.01 μ f Cer	4000 v
C854	283-082	0.01 μ f Cer	4000 v

Parts List—Type 547

Capacitors (Cont'd)

Ckt. No.	Tektronix Part No.		Description			S/N Range
C858	283-082	0.01 μ f	Cer	4000 v		
C863	283-002	0.01 μ f	Cer	500 v		
C932	283-041	0.0033 μ f	Cer	500 v	5%	
C934	283-032	470 pf	Cer	500 v	5%	
C939	283-057	0.1 μ f	Cer	200 v		
C941	283-006	0.02 μ f	Cer	600 v		
C944	283-057	0.1 μ f	Cer	200 v		
C958	281-525	470 pf	Cer	500 v		
C965	281-523	100 pf	Cer	350 v		
C1000	281-601	7.5 pf	Cer	500 v	± 0.5 pf	
C1002	283-001	0.005 μ f	Cer	500 v		
C1014	283-067	0.001 μ f	Cer	200 v	10%	
C1016	281-519	47 pf	Cer	500 v	10%	
C1019	Use 281-0505-00	12 pf	Cer	500 v	10%	X1272-up
C1024	283-067	0.001 μ f	Cer	200 v	10%	
C1026	281-519	47 pf	Cer	500 v	10%	
C1027	281-558	18 pf	Cer	500 v		100-4749
C1027	281-0061-00	5.5-18 pf	Cer	Var		4750-up
C1028	283-001	0.005 μ f	Cer	500 v		
C1029	281-006	1.5-7 pf	Cer	Var		
C1031	281-572	6.8 pf	Cer	500 v	± 0.5 μ f	
C1035	283-067	0.001 μ f	Cer	200 v	10%	100-4269
C1035	283-0078-00	0.001 μ f	Cer	500 v		4270-up
C1038	283-067	0.001 μ f	Cer	200 v	10%	100-4269
C1038	283-0078-00	0.001 μ f	Cer	500 v		4270-up
C1042	281-572	6.88 pf	Cer	500 v	± 0.5 μ f	
C1048	283-067	0.001 μ f	Cer	200 v	10%	100-4269
C1048	283-0078-00	0.001 μ f	Cer	500 v		4270-up
C1069	283-067	0.001 μ f	Cer	200 v	10%	100-4269
C1069	283-0078-00	0.001 μ f	Cer	500 v		4270-up
C1071	283-067	0.001 μ f	Cer	200 v	10%	100-4269
C1071	283-0078-00	0.001 μ f	Cer	500 v		4270-up
C1074	281-503	8 pf	Cer	500 v	± 0.5 pf	
C1076	281-075	5-25 pf	Cer	Var		100-10729
C1076	281-0123-00	5-25 pf	Cer	Var		10730-up
C1077	281-549	68 pf	Cer	500 v	10%	100-10729
C1077	281-0540-00	51 pf	Cer		5%	10730-up
C1087	283-067	0.001 μ f	Cer	200 v	10%	100-4269
C1087	283-0078-00	0.001 μ f	Cer	500 v		4270-up
C1091	281-0605-00	200 pf	Cer	500 v		X10730-up
C1103	281-511	22 pf	Cer	500 v	10%	
C1104	281-524	150 pf	Cer	500 v		
C1105	281-075	5-25 pf	Cer	Var		
C1106	281-075	5-25 pf	Cer	Var		
C1107	281-600	35 pf	Cer		10%	
C1113	283-067	0.001 μ f	Cer	200 v	10%	100-4269
C1113	283-0078-00	0.001 μ f	Cer	500 v		4270-up
C1116	283-001	0.005 μ f	Cer	500 v		
C1124	281-524	150 pf	Cer	500 v		
C1126	281-075	5-25 pf	Cer	Var		
C1127	281-558	18 pf	Cer	500 v		
C1132	283-067	0.001 μ f	Cer	200 v	10%	100-4269
C1132	283-0078-00	0.001 μ f	Cer	500 v		4270-up
C1142	283-067	0.001 μ f	Cer	200 v	10%	
C1152	283-067	0.001 μ f	Cer	200 v	10%	

Capacitors (Cont'd)

Ckt. No.	Tektronix Part No.	Description	S/N Range
C1153	283-001	0.005 μ f Cer	500 v
C1157	Use 283-057	0.1 μ f Cer	200 v
C1161	283-001	0.005 μ f Cer	500 v
C1163	283-006	0.02 μ f Cer	600 v
C1165	281-0512-00	27 pf Cer	500 v 10% X6740-up
C1175	281-0512-00	27 pf Cer	500 v 10% X6740-up
C1181	283-067	0.001 μ f Cer	200 v 10%
C1191	283-067	0.001 μ f Cer	200 v 10%

Connector

J11	131-018	16 contact, female, chassis mounted
-----	---------	-------------------------------------

Diodes

D21	*152-0075-00	Germanium	Tek Spec				X6740-up
D22	*152-0075-00	Germanium	Tek Spec				X6740-up
D45	152-154	Tunnel	TD253	10 MA			100-11889
D45	152-0140-01	Tunnel	8 pf	10 MA			11890-up
D57	*152-075	Germanium	Tek Spec				
D59	*152-075	Germanium	Tek Spec				
D69	152-141	Silicon	1N4152				100-10429
D69	152-0141-02	Silicon	1N4152				10430-up
D71	152-141	Silicon	1N4152				100-10429
D71	152-0141-02	Silicon	1N4152				10430-up
D76	152-119	Zener	1N969A	0.4 w	22 v	10%	100-8629
D76	152-0281-00	Zener	1N969B	0.4 w	22 v	5%	8630-up
D79	152-141	Silicon	1N4152				100-10429
D79	152-0141-02	Silicon	1N4152				10430-up
D83	*152-075	Germanium	Tek Spec				
D85	Use *152-0125-00	Tunnel	Selected TD3A	4.7 MA			
D86	*152-161	Tek	GaAs				100-12479
D86	*152-0185-00	Silicon	Replaceable by 1N4152				12480-up
D90	*152-0165-00	Silicon	Selected from 1N3579				X3130-up
D97	152-118	Zener	1N3033	1 w	36 v	20%	100-8629
D97	152-0294-00	Zener	1N3033B	1 w	36 v	5%	8630-up
D98	*152-061	Silicon	Tek Spec				
D100	*152-061	Silicon	Tek Spec				
D129	*152-061	Silicon	Tek Spec				
D132	*152-061	Silicon	Tek Spec				
D133	152-141	Silicon	1N4152				100-10429
D133	152-0141-02	Silicon	1N4152				10430-up
D134	152-141	Silicon	1N4152				100-10429
D134	152-0141-02	Silicon	1N4152				10430-up
D136	*152-075	Germanium	Tek Spec				
D147	152-141	Silicon	1N4152				100-10429
D147	152-0141-02	Silicon	1N4152				10430-up
D163	152-141	Silicon	1N4152				100-10429
D163	152-0141-02	Silicon	1N4152				10430-up
D164	*152-075	Germanium	Tek Spec				
D172	*152-061	Silicon	Tek Spec				
D181	152-141	Silicon	1N4152				100-10429
D181	152-0141-02	Silicon	1N4152				10430-up
D182	Use *050-225	Silicon	Replacement Kit				100-1159
D182	152-141	Silicon	1N4152				1160-10429
D182	152-0141-02	Silicon	1N4152				10430-up
D183	152-141	Silicon	1N4152				100-10429

Parts List—Type 547

Diodes (Cont'd)

Ckt. No.	Tektronix Part No.	Description	S/N Range
D183	152-0141-02	Silicon 1N4152	10430-up
D194	*152-0061-00	Silicon Tek Spec	X1970-up
D221	*152-0075-00	Germanium Tek Spec	X6740-up
D222	*152-0075-00	Germanium Tek Spec	X6740-up
D245	152-154	Tunnel TD253 10 MA	100-11889
D245	152-0140-01	Tunnel 8 pf 10 MA	11890-up
D257	*152-075	Germanium Tek Spec	
D259	*152-075	Germanium Tek Spec	
D265	152-008	Germanium	
D269	152-141	Silicon 1N4152	100-10429
D269	152-0141-02	Silicon 1N4152	10430-up
D271	152-141	Silicon 1N4152	100-10429
D271	152-0141-02	Silicon 1N4152	10430-up
D277	152-119	Zener 1N969A 0.4 w 22 v 10%	100-8629
D277	152-0281-00	Zener 1N969B 0.4 w 22 v 5%	8630-up
D279	152-141	Silicon 1N4152	100-10429
D279	152-0141-02	Silicon 1N4152	10430-up
D283	*152-075	Germanium Tek Spec	
D285	Use *152-0125-00	Tunnel Selected TD3A 4.7 MA	
D286	*152-161	Tek GaAs	100-12479
D286	*152-0185-00	Silicon Replaceable by 1N4152	12480-up
D291	*152-0165-00	Silicon Tek Spec	X12480-up
D297	152-118	Zener 1N3033 1 w 36 v 20%	100-8629
D297	152-0294-00	Zener 1N3033B 1 w 36 v 5%	8630-up
D298	*152-061	Silicon Tek Spec	
D300	*152-061	Silicon Tek Spec	
D329	*152-061	Silicon Tek Spec	
D332	*152-061	Silicon Tek Spec	
D347	152-141	Silicon 1N4152	100-10429
D347	152-0141-02	Silicon 1N4152	10430-up
D355	152-141	Silicon 1N4152	100-10429
D355	152-0141-02	Silicon 1N4152	10430-up
D356	152-141	Silicon 1N4152	100-10429
D356	152-0141-02	Silicon 1N4152	10430-up
D362	152-141	Silicon 1N4152	100-10429
D362	152-0141-02	Silicon 1N4152	10430-up
D363	152-141	Silicon 1N4152	100-10429
D363	152-0141-02	Silicon 1N4152	10430-up
D367	152-141	Silicon 1N4152	100-10429
D367	152-0141-02	Silicon 1N4152	10430-up
D372	*152-061	Silicon Tek Spec	
D405	Use 152-0081-00	Tunnel 1D2 2.2 MA	100-11489
D405	152-0402-00	Tunnel 2.2 MA (Note diode polarity)	11490-up
D433	Use *152-061	Silicon Tek Spec	
D441	152-141	Silicon 1N4152	100-10429
D441	152-0141-02	Silicon 1N4152	10430-up
D448	*152-075	Germanium Tek Spec	
D449	152-008	Germanium	
D455	152-141	Silicon 1N4152	100-10429
D455	152-0141-02	Silicon 1N4152	10430-up
D461	152-141	Silicon 1N4152	100-10429
D461	152-0141-02	Silicon 1N4152	10430-up
D462	*152-161	Tek GaAs	100-12479
D462	*152-0153-00	Silicon Tek Spec	12480-up
D464	152-141	Silicon 1N4152	100-10429
D464	152-0141-02	Silicon 1N4152	10430-up
D469	152-141	Silicon 1N4152	100-10429

Diodes (Cont'd)

Ckt. No.	Tektronix Part No.	Description					S/N Range
D469	152-0141-02	Silicon	1N4152				10430-up
D471	152-141	Silicon	1N4152				100-10429
D471	152-0141-02	Silicon	1N4152				10430-up
D472	*152-161	Tek	GaAs				100-12479
D472	*152-0153-00	Silicon	Tek Spec				12480-up
D474	152-141	Silicon	1N4152				100-10429
D474	152-0141-02	Silicon	1N4152				10430-up
D475	152-147	Zener	1N971B	0.4 w	27 v	5%	
D479	152-141	Silicon	1N4152				100-10429
D479	152-0141-02	Silicon	1N4152				10430-up
D481	152-141	Silicon	1N4152				100-10429
D481	152-0141-02	Silicon	1N4152				10430-up
D482	152-141	Silicon	1N4152				100-10429
D482	152-0141-02	Silicon	1N4152				10430-up
D492	152-141	Silicon	1N4152				100-10429
D492	152-0141-02	Silicon	1N4152				10430-up
D541	152-067	Zener	1M25Z10	1 w	25 v	10%	100-8629
D541	152-0022-00	Zener	1N25Z5	1 w	25 v	5%	8630-up
D542	*152-075	Germanium	Tek Spec				100-5679
D542	*152-0061-00	Silicon	Tek Spec				5680-up
D561	*152-075	Germanium	Tek Spec				100-5679
D561	*152-0061-00	Silicon	Tek Spec				5680-up
D582	*152-061	Silicon	Tek Spec				
D642A,B,C,D, D672A,B,C,D	152-066	Silicon	1N3194				
	*152-047	Replaceable by 1N2862					100-4399
D672A,B,C,D	152-0066-00	Silicon	1N3194				4400-12109
D672A,B,C,D	152-0423-00	Silicon	300 V	3 A			12110-up
D693	152-157	Zener	4A1140Z10	0.4 w	140 v	10%	100-7329X
D694	*152-0107-00	Silicon Replaceable by 1N647					X7330-up
D702A,B	152-066	Silicon	1N3194				
D732A,B	152-066	Silicon	1N3194				
D759	152-141	Silicon	1N4152				100-10429
D759	152-0141-02	Silicon	1N4152				10430-up
D760	*152-0075-00	Germanium	Tek Spec				X1728-up
D769	*152-061	Silicon	Tek Spec				
D803	*152-0107-00	Silicon	Replaceable by 1N647				X5830-up
D804	152-0265-00	Zener	1N970B	0.4 w	24 V	5%	X5830-up
D831	152-208	Silicon	1N3195				X1880-7479
D831	152-0040-00	Silicon	1N2615				7480-up
D942	*152-061	Silicon	Tek Spec				
D948	152-004	Zener	1N707 or 1N763	1/4 w	6.2-8 v		100-3149X
D1014	152-141	Silicon	1N4152				100-10429
D1014	152-0141-02	Silicon	1N4152				10430-up
D1018	152-120	Zener	1N3020B	1 w	10 v	5%	
D1024	152-141	Silicon	1N4152				100-10429
D1024	152-0141-02	Silicon	1N4152				10430-up
D1109	152-0228-00	Zener	3/4M105Z10	1 w	105 v	10%	X2340-8629
D1109	152-0305-00	Zener	1N3045B	1 w	110 v	5%	8630-up
D1114	*152 0107-00	Silicon	Replaceable by 1N647				X11270-up

Fuse

F601	159-011	6.25 Amps	3AG	Slo-Blo, 115 v, 50-60 and 400 cps	
	159-005	3 Amps	3AG	Slo-Blo, 230 v, 50-60 and 400 cps	
F602	159-0005-00	3 Amps	3AG	Slo-Blo, 230 v, 50-60 and 400 cps	X7980-up

Parts List—Type 547

Inductors

Ckt. No.	Tektronix Part No.	Description	S/N Range
LR21	*108-230	3.25 μ h (on a 150 Ω $\frac{1}{2}$ w 5% resistor)	
LR23	*108-230	3.25 μ h (on a 150 Ω $\frac{1}{2}$ w 5% resistor)	
L44	276-507	Core, Ferramic Suppressor	100-6739X
L50	*108-0146-00	5 μ h	X6740-up
L52	*108-147	2.2 μ h	100-6739X
L56	*108-215	1.1 μ h	
L85	*108-0410-00	1 μ h	X6740-up
LR221	*108-230	3.25 μ h (on a 150 Ω $\frac{1}{2}$ w 5% resistor)	
LR223	*108-230	3.25 μ h (on a 150 Ω $\frac{1}{2}$ w 5% resistor)	
L244	276-507	Core, Ferramic Suppressor	100-6739X
L250	*108-0146-00	5 μ h	X6740-up
L252	*108-147	2.2 μ h	100-6739X
L256	*108-215	1.1 μ h	
L285	*108-0410-00	1 μ h	X6740-up
L404	*120-309	Toroid, 6T Single	
L553	*119-030	Delay Line Assembly	
L760	108-240	820 μ h	
L778	Use *108-323	Beam Rotator	
L1013	*108-260	0.1 μ h	
L1018	*120-266	Toroid, 10T Single	
L1023	*108-260	0.1 μ h	
L1030	*108-264	0.2 μ h	
L1040	*108-264	0.2 μ h	
L1051	*108-260	0.1 μ h	
LR1052	*108-288	1.2 μ h (on a 6.2 Ω $\frac{1}{2}$ w 5% resistor)	
L1061	*108-260	0.1 μ h	
LR1062	*108-288	1.2 μ h (on a 6.2 Ω $\frac{1}{2}$ w 5% resistor)	
L1072	*108-260	0.1 μ h	
L1082	*108-260	0.1 μ h	
LR1115	*131-335	0.5 μ h (on a 330 Ω $\frac{1}{4}$ w resistor) (brown)	
LR1135	*131-336	0.5 μ h (on a 330 Ω $\frac{1}{4}$ w resistor) (blue)	
L1144	*108-095	1.4 μ h	
L1145	276-0507-00	Core, Ferramic Suppressor	X14640-up
L1154	*108-095	1.4 μ h	
L1155	276-0507-00	Core, Ferramic Suppressor	X14640-up
L1157	*114-080	6.8 μ h - 14.6 μ h Var	Core 276-0506-00
L1160	276-528	Core, Ferramic Suppressor	
L1170	276-528	Core, Ferramic Suppressor	

Relays

K600	148-021	Tube Relay
K601	*148-019	Tek Spec

Transistors

Q34	151-089	2N962	100-6059
Q34	151-0188-00	2N3906	6060-6739
Q34	*151-0199-00	Silicon Replaceable by MPS-3640	6740-up
Q44	151-089	2N962	100-6059
Q44	151-0188-00	2N3906	6060-6739
Q44	*151-0199-00	Silicon Replaceable by MPS-3640	6740-up
Q65	*151-108	Replaceable by 2N2501	
Q75	*151-108	Replaceable by 2N2501	
Q84	*151-108	Replaceable by 2N2501	100-12479
Q84	151-0190-00	2N3904	12480-up

Transistors (Cont'd)

Ckt. No.	Tektronix Part No.	Description	S/N Range
Q86	151-0277-00	RCA 38520	X12480-up
Q89	*151-096	Selected from 2N1893	
Q103	151-089	2N962	100-6059
Q103	151-0188-00	2N3906	6060-up
Q173	151-063	2N2207	
Q184	151-063	2N2207	
Q234	151-089	2N962	100-6059
Q234	151-0188-00	2N3906	6060-6739
Q234	*151-0199-00	Silicon Replaceable by MPS-3640	6740-up
Q244	151-089	2N962	100-6059
Q244	151-0188-00	2N3906	6060-6739
Q244	151-0199-00	Silicon Replaceable by MPS-3640	6740-up
Q265	*151-108	Replaceable by 2N2501	
Q275	*151-108	Replaceable by 2N2501	
Q284	*151-108	Replaceable by 2N2501	100-12479
Q284	151-0190-00	2N3904	12480-up
Q286	151-0277-00	RCA 38520	X12480-up
Q289	*151-096	Selected from 2N1893	
Q303	151-089	2N962	100-6059
Q303	151-0188-00	2N3906	6060-up
Q344	*151-096	Selected from 2N1893	
Q373	151-063	2N2207	
Q424	151-063	2N2207	100-14709
Q424	*151-0322-00	Replaceable by 2N4890	14710-up
Q433	*151-103	Replaceable by 2N2219	
Q444	*151-103	Replaceable by 2N2219	
Q454	*151-103	Replaceable by 2N2219	
Q464	*151-108	Replaceable by 2N2501	
Q465	*151-108	Replaceable by 2N2501	
Q475	*151-108	Replaceable by 2N2501	
Q534	*151-121	Selected from TA1938	100-15299
Q534	*151-0124-00	Selected from 2N3501	15300-up
Q543	*151-096	Selected from 2N1893	
Q554	151-063	2N2207	100-14709
Q554	*151-0322-00	Replaceable by 2N4890	14710-up
Q564	151-063	2N2207	100-14709
Q564	*151-0322-00	Replaceable by 2N4890	14710-up
Q1014	*153-525	Matched pair (Selected from 2N2475)	
Q1024			
Q1034	*153-527	Matched pair (Replaceable by 2N2501)	
Q1044			
Q1074			
Q1084	*153-525	Matched pair (Selected from 2N2475)	
Q1104†	*153-526	Selected from 2N2369	
Q1109	151-0149-00	2N3441	X2340-up
Q1114††	*153-524	Selected from TA1938	100-5679
Q1114††	*153-0548-00	Selected from 2N3119	5680-up
Q1124†	*153-526	Selected from 2N2369	
Q1134††	*153-524	Selected from TA1938	100-5679
Q1134††	*153-0548-00	Selected from 2N3119	5680-up
Q1144	*153-527	Matched pair (Replaceable by 2N2501)	
Q1154			
Q1163	*151-127	Selected from 2N2369	
Q1173	*151-127	Selected from 2N2369	

†Q1104 and Q1124 furnished as a matched pair.

††Q1114 and Q1134 furnished as a matched pair.

Parts List—Type 547

Resistors

Ckt. No.	Tektronix Part No.		Description			S/N Range
Resistors are fixed, composition, $\pm 10\%$ unless otherwise indicated.						
R5	302-104	100 k	$\frac{1}{2}$ w			
R6	321-385	100 k	$\frac{1}{16}$ w		Prec	1%
R7	323-406	165 k	$\frac{1}{2}$ w		Prec	1%
R8	316-101	100 Ω	$\frac{1}{4}$ w			
R9	311-018	20 k		Var		B INT TRIG DC LEVEL
R13	323-481	1 meg	$\frac{1}{2}$ w		Prec	1%
R14	302-155	1.5 meg	$\frac{1}{2}$ w			
R15†	311-426	300 k		Var		TRIGGERING LEVEL
R16	302-394	390 k	$\frac{1}{2}$ w			
R17	302-335	3.3 meg	$\frac{1}{2}$ w			
R18	302-104	100 k	$\frac{1}{2}$ w			
R19	316-105	1 meg	$\frac{1}{4}$ w			
R20	316-101	100 Ω	$\frac{1}{4}$ w			
R21	316-221	220 Ω	$\frac{1}{4}$ w			100-6739
R21	315-0471-00	470 Ω	$\frac{1}{4}$ w			5% 6740-up
R22	316-101	100 Ω	$\frac{1}{4}$ w			
R23	316-221	220 Ω	$\frac{1}{4}$ w			100-6739
R23	315-0471-00	470 Ω	$\frac{1}{4}$ w			5% 6740-up
R24	308-108	15 k	5 w		WW	5%
R25	311-158	200 Ω		Var		B TRIGGER LEVEL CENTERING
R27	308-267	7.5 k	5 w		WW	5%
R28	302-102	1 k	$\frac{1}{2}$ w			
R32	315-0471-00	470 Ω	$\frac{1}{4}$ w			5% X6740-up
R33	308-0301-00	10 k	3 w		WW	1% X6740-up
R36	324-335	30.1 k	1 w		Prec	1% 100-6739
R36	308-0320-00	15.6 k	3 w		WW	1% 6740-up
R41	316-221	220 Ω	$\frac{1}{4}$ w			100-6739X
R42	315-0471-00	470 Ω	$\frac{1}{4}$ w			5% X6740-up
R43	316-100	10 Ω	$\frac{1}{4}$ w			100-6739X
R44	322-001	10 Ω	$\frac{1}{4}$ w		Prec	1% 100-6739X
R45	311-324	50 Ω	$\frac{1}{2}$ w	Var	WW	B TRIGGER SENS 100-6739
R45	311-0405-00	10 k		Var		B TRIGGER SENS 6740-up
R46	308-0310-00	12 k	5 w		WW	1% X6740-up
R47	324-306	15 k	1 w		Prec	1% 100-6739X
R48	324-306	15 k	1 w		Prec	1% 100-6739X
R49	302-101	100 Ω	$\frac{1}{2}$ w			
R50	302-101	100 Ω	$\frac{1}{2}$ w			
R51	302-101	100 Ω	$\frac{1}{2}$ w			
R52	315-0560-00	56 Ω	$\frac{1}{4}$ w			5% X6740-up
R53	323-370	69.8 k	$\frac{1}{2}$ w		Prec	1%
R54	323-140	280 Ω	$\frac{1}{2}$ w		Prec	1%
R57	302-224	220 k	$\frac{1}{2}$ w			100-6739
R57	302-0104-00	100 k	$\frac{1}{2}$ w			6740-up
R63	316-470	47 Ω	$\frac{1}{4}$ w			
R65	301-303	30 k	$\frac{1}{2}$ w			5%
R67	301-912	9.1 k	$\frac{1}{2}$ w			5%

†Furnished as a unit with SW15.

Resistors (Cont'd)

Ckt. No.	Tektronix Part No.		Description			S/N Range
R69	302-103	10 k	1/2 w			
R71	303-513	51 k	1 w		5%	
R75	301-513	51 k	1/2 w		5%	100-6739
R75	303-0243-00	24 k	1 w		5%	6740-up
R76	302-471	470 Ω	1/2 w			100-6739
R76	301-0221-00	220 Ω	1/2 w		5%	6740-up
R78	301-752	7.5 k	1/2 w		5%	
R79	302-152	1.5 k	1/2 w			
R79	302-0561-00	560 Ω	1/2 w			100-6739
R81	316-101	100 Ω	1/4 w			6740-up
R81	315-0181-00	180 Ω	1/4 w		5%	100-6739
R82	323-333	28.7 k	1/2 w	Prec	1%	100-6739
R82	323-0636-00	50 k	1/2 w	Prec	1%	6740-up
R83	316-394	390 k	1/4 w			
R84	305-153	15 k	2 w		5%	
R85	315-102	1 k	1/4 w		5%	
R86	303-513	51 k	1 w		5%	
R87	315-273	27 k	1/4 w		5%	
R88	302-823	82 k	1/2 w			
R89	302-105	1 meg	1/2 w			
R90A	*312-640	140 k	1/2 w		1%	
R90B		280 k	1/2 w		1%	
R90C		700 k	1/2 w		1%	
R90D	*312-641	1.4 meg	1/2 w		1%	
R90E		2.8 meg	1/2 w		1%	100-5479
R90F		7 meg	1/2 w		1%	
R90D	*312-0641-01	1.4 meg	1/2 w		1%	
R90E		2.8 meg	1/2 w		1%	5480-8299
R90F		7 meg	1/2 w		1%	
R90G	*312-0641-02	47 k	(nominal value) Selected			
R90D		1.4 meg	1/2 w		1%	
R90E		2.8 meg	1/2 w		1%	
R90F	*312-0641-03	7 meg	1/2 w		1%	8300-10259
R90G		47 k	(nominal value) Selected			
R90H		39 k	(nominal value) Selected			
R90D	*312-0641-04	1.4 meg	1/2 w		1%	
R90E		2.8 meg	1/2 w		1%	
R90F		7 meg	1/2 w		1%	10260-15299
R90G	*312-0641-04	47 k	(nominal value) Selected			
R90H		39 k	(nominal value) Selected			15300-up
R90J		10 k	(nominal value) Selected			
R90K	302-271	270 Ω	1/2 w			
R90W	302-105	1 meg	1/2 w			
R90X	302-104	100 k	1/2 w			
R90Y	301-392	3.9 k	1/2 w			
R90Z†	311-391	150 k		Var	5% VARIABLE	
R91	308-0400-00	18 k	5 w		WW	5% X12480-up
R92	316-101	100 Ω	1/4 w			
R93	304-473	47 k	1 w			
R94	304-473	47 k	1 w			
R95	316-101	100 Ω	1/4 w			
R96	316-101	100 Ω	1/4 w			
R97	315-0102-00	1 k	1/4 w		5%	X12480-up

†Furnished as a unit with SW90Z.

Parts List—Type 547

Resistors (Cont'd)

Ckt. No.	Tektronix Part No.		Description		S/N Range
R98	315-303	30 k	1/4 w		5%
R99	323-356	49.9 k	1/2 w	Prec	1%
R100	316-272	2.7 k	1/4 w		
R101	316-122	1.2 k	1/4 w		
R102	316-153	15 k	1/4 w		
R103	306-273	27 k	2 w		
R105	316-152	1.5 k	1/4 w		
R121	306-683	68 k	2 w		
R124	303-163	16 k	1 w		5%
R125	311-011	5 k		Var	B SWEEP LENGTH
R126	305-393	39 k	2 w		5%
R128	302-102	1 k	1/2 w		
R129	302-562	5.6 k	1/2 w		
R130A	302-155	1.5 meg	1/2 w		
R130C	301-156	15 meg	1/2 w		5%
R132	302-824	820 k	1/2 w		
R135	323-385	100 k	1/2 w	Prec	1%
R136	301-113	11 k	1/2 w		5%
R137	323-481	1 meg	1/2 w	Prec	1%
R138	309-439	5.9 meg	1/2 w	Prec	1%
R139	316-101	100 Ω	1/4 w		
R141	301-334	330 k	1/2 w		5%
R142	301-274	270 k	1/2 w		5%
R143	301-683	68 k	1/2 w		5%
R144	302-101	100 Ω	1/2 w		
R145	323-302	13.7 k	1/2 w	Prec	1%
R146	323-385	100 k	1/2 w	Prec	1%
R147	323-402	150 k	1/2 w	Prec	1%
R148	316-101	100 Ω	1/4 w		
R149	302-122	1.2 k	1/2 w		
R162	323-243	3.32 k	1/2 w	Prec	1%
R163	308-268	22 k	5 w	WW	1%
R164	324-339	33.2 k	1 w	Prec	1%
R165	301-183	18 k	1/2 w		5%
R166	301-134	130 k	1/2 w		5%
R170	315-472	4.7 k	1/4 w		5%
R171	302-472	4.7 k	1/2 w		
R172	302-274	270 k	1/2 w		
R173	316-101	100 Ω	1/4 w		
R174	308-272	20 k	5 w	WW	5%
R175	323-0414-00	200 k	1/2 w	Prec	1%
R176	316-270	27 Ω	1/4 w		
R177	323-289	10 k	1/2 w	Prec	1%
R178	316-102	1 k	1/4 w		
R179	323-330	26.7 k	1/2 w	Prec	1%
R180	316-470	47 Ω	1/4 w		
R181	301-363	36 k	1/2 w		5%
R181	323-280	8.06 k	1/2 w	Prec	1%
R182	302-274	270 k	1/2 w		100-1159
R182	323-356	49.9 k	1/2 w	Prec	1%
R183	323-348	41.2 k	1/2 w	Prec	1%
R184	323-353	46.4 k	1/2 w	Prec	1%
R185	309-447	6.19 meg	1/2 w	Prec	1%
					100-1969

Resistors (Cont'd)

Ckt. No.	Tektronix Part No.	Description	S/N Range
R185	309-0451-00	3.92 meg 1/2 w	Prec 1% 1970-up
R186	323-469	750 k 1/2 w	Prec 1%
R187	309-448	9.31 meg 1/2 w	Prec 1% 100-1969
R187	309-0447-00	6.19 meg 1/2 w	Prec 1% 1970-up
R188	316-100	10 Ω 1/4 w	
R189	311-419	500 k	Var BRIGHTNESS
R190	316-101	100 Ω 1/4 w	
R191	316-470	47 Ω 1/4 w	
R192	316-470	47 Ω 1/4 w	
R193	302-104	100 k 1/2 w	
R194	316-820	82 Ω 1/4 w	
R195	323-620	800 k 1/2 w	Prec 1%
R196	316-470	47 Ω 1/4 w	
R197	316-470	47 Ω 1/4 w	
R198	302-472	4.7 k 1/2 w	
R199	302-103	10 k 1/2 w	
R205	302-104	100 k 1/2 w	
R206	321-385	100 k 1/4 w	Prec 1%
R207	323-406	165 k 1/2 w	Prec 1%
R209	311-018	20 k	Var A INT TRIG DC LEVEL
R210	316-103	10 k 1/4 w	
R211	316-222	2.2 k 1/4 w	
R213	323-481	1 meg 1/2 w	Prec 1%
R214	302-155	1.5 meg 1/2 w	
R215†	311-426	300 k	Var TRIGGERING LEVEL
R216	302-394	390 k 1/2 w	
R217	302-335	3.3 meg 1/2 w	
R218	302-104	100 k 1/2 w	
R219	316-105	1 meg 1/4 w	
R220	Use 316-0101-00	100 Ω 1/4 w	
R221	316-221	220 Ω 1/4 w	100-6739
R221	315-0471-00	470 Ω 1/4 w	5% 6740-up
R222	Use 316-0101-00	100 Ω 1/4 w	
R223	316-221	220 Ω 1/4 w	100-6739
R223	315-0471-00	470 Ω 1/4 w	5% 6740-up
R224	308-108	15 k 5 w	
R225	311-004	200 Ω	Var A TRIGGER LEVEL CENTERING
R227	308-267	7.5 k 5 w	WW
R228	302-102	1 k 1/2 w	
R232	315-0471-00	470 Ω 1/4 w	5% X6740-up
R233	308-0301-00	10 k 3 w	WW 1% X6740-up
R236	324-335	30.1 k 1 w	Prec 1% 100-6739
R236	308-0320-00	15.6 k 3 w	WW 1% 6740-up
R241	316-221	220 Ω 1/4 w	100-6739X
R242	315-0471-00	470 Ω 1/4 w	5% X6740-up
R243	316-100	10 Ω 1/4 w	100-6739X
R244	323-001	10 Ω 1/2 w	Prec 1% 100-6739X
R245	311-308	50 Ω 2 w	Var A TRIGGER SENS 100-6739
R245	311-0076-00	10 k	Var A TRIGGER SENS 6740-up
R246	308-0310-00	12 k 5 w	WW 1% X6740-up
R247	324-306	15 k 1 w	Prec 1% 100-6739X
R248	324-306	15 k 1 w	Prec 1% 100-6739X
R249	302-101	100 Ω 1/2 w	

†Furnished as a unit with SW215.

Parts List—Type 547

Resistors (Cont'd)

Ckt. No.	Tektronix Part No.		Description			S/N Range
R252	315-0560-00	56 Ω	1/4 w		5%	X6740-up
R253	323-370	69.8 k	1/2 w	Prec	1%	
R254	323-140	280 Ω	1/2 w	Prec	1%	
R255	301-203	20 k	1/2 w		5%	
R256	301-134	130 k	1/2 w		5%	100-6739
R256	301-0304-00	300 k	1/2 w		5%	6740-up
R258	302-473	47 k	1/2 w			
R263	316-470	47 Ω	1/4 w			
R265	301-303	30 k	1/2 w		5%	
R267	301-912	9.1 k	1/2 w		5%	
R269	316-103	10 k	1/4 w			
R271	303-513	51 k	1 w		5%	
R275	301-513	51 k	1/2 w		5%	100-6739
R275	303-0243-00	24 k	1 w		5%	6740-up
R276	302-471	470 Ω	1/2 w			100-6739
R276	301-0221-00	220 Ω	1/2 w		5%	6740-up
R278	301-752	7.5 k	1/2 w		5%	
R279	302-152	1.5 k	1/2 w			100-6739
R279	302-0561-00	560 Ω	1/2 w			6740-up
R281	316-101	100 Ω	1/4 w			100-6739
R281	315-0181-00	180 Ω	1/4 w		5%	6740-up
R282	323-333	28.7 k	1/2 w		1%	100-6739
R282	323-0636-00	50 k	1/2 w	Prec	1%	6740-up
R283	316-394	390 k	1/4 w	Prec	1%	
R284	305-153	15 k	2 w		5%	
R285	301-102	1 k	1/2 w		5%	
R286	303-513	51 k	1 w		5%	
R287	301-273	27 k	1/2 w		5%	
R288	302-823	82 k	1/2 w			
R289	302-105	1 meg	1/2 w			
R290A	*312-640	140 k	1/2 w		1%	
R290B		280 k	1/2 w		1%	
R290C		700 k	1/2 w		1%	
R290D		1.4 meg	1/2 w		1%	
R290E	*312-641	2.8 meg	1/2 w		1%	100-5479
R290F		7 meg	1/2 w		1%	
R290D		1.4 meg	1/2 w		1%	
R290E		2.8 meg	1/2 w		1%	
R290F	*312-0641-01	7 meg	1/2 w		1%	5480-8299
R290G		47 k	(nominal value) Selected			
R290D		1.4 meg	1/2 w		1%	
R290E		2.8 meg	1/2 w		1%	
R290F	*312-0641-02	7 meg	1/2 w		1%	8300-10259
R290G		47 k	(nominal value) Selected			
R290H		39 k	(nominal value) Selected			
R290D		1.4 meg	1/2 w		1%	
R290E	*312-0641-03	2.8 meg	1/2 w		1%	10260-15299
R290F		7 meg	1/2 w		1%	
R290G		47 k	(nominal value) Selected			
R290H		39 k	(nominal value) Selected			
R290D	*312-0641-04	1.4 meg	1/2 w			15300-up
R290E		2.8 meg	1/2 w			
R290F		7 meg	1/2 w			
R290G		47 k	(nominal value) Selected			
R290H		39 k	(nominal value) Selected			
R290J		10 k	(nominal value) Selected			
R290W	302-105	1 meg	1/2 w			
R290X	302-104	100 k	1/2 w			
R290Y	311-388	7.5 k		Var	WW	A SWEEP CAL
R290Z†	311-391	150 k		Var		VARIABLE

†Furnished as a unit with SW290Z.

Resistors (Cont'd)

Ckt. No.	Tektronix Part No.		Description			S/N Range
R292	316-101	100 Ω	$\frac{1}{4}$ w			
R293	304-473	47 k	1 w			
R294	304-473	47 k	1 w			
R295	316-101	100 Ω	$\frac{1}{4}$ w			
R296	316-101	100 Ω	$\frac{1}{4}$ w			
R297	308-0400-00	18 k	5 w	WW	5%	X12480-up
R298	315-0102-00	1 k	$\frac{1}{4}$ w		5%	X12480-up
R299	323-356	49.9 k	$\frac{1}{2}$ w	Prec	1%	
R300	315-0272-00	2.7 k	$\frac{1}{4}$ w		5%	X12480-up
R301	316-471	470 Ω	$\frac{1}{4}$ w			
R302	316-153	15 k	$\frac{1}{4}$ w			
R303	306-273	27 k	2 w			
R305	316-152	1.5 k	$\frac{1}{4}$ w			
R310	301-272	2.7 k	$\frac{1}{2}$ w		5%	
R311	302-104	100 k	$\frac{1}{2}$ w			
R312	316-101	100 Ω	$\frac{1}{4}$ w			
R314	316-101	100 Ω	$\frac{1}{4}$ w			
R316	302-104	100 k	$\frac{1}{2}$ w			
R321	306-683	68 k	2 w			
R324	303-163	16 k	1 w		5%	
R325	311-011	5 k		Var		A SWEEP LENGTH
R326	305-393	39 k	2 w		5%	
R328	302-102	1 k	$\frac{1}{2}$ w			
R329	302-562	5.6 k	$\frac{1}{2}$ w			
R330A	301-155	1.5 meg	$\frac{1}{2}$ w		5%	
R330B	301-565	5.6 meg	$\frac{1}{2}$ w		5%	
R330C	301-156	15 meg	$\frac{1}{2}$ w		5%	
R330D	301-226	22 meg	$\frac{1}{2}$ w		5%	
R334	323-373	75 k	$\frac{1}{2}$ w	Prec	1%	
R335	323-273	6.81 k	$\frac{1}{2}$ w	Prec	1%	
R337	323-481	1 meg	$\frac{1}{2}$ w	Prec	1%	
R338	309-439	5.9 meg	$\frac{1}{2}$ w	Prec	1%	
R339	316-101	100 Ω	$\frac{1}{4}$ w			
R341	301-334	330 k	$\frac{1}{2}$ w		5%	
R342	301-274	270 k	$\frac{1}{2}$ w		5%	
R343	301-683	68 k	$\frac{1}{2}$ w		5%	
R344	302-101	100 Ω	$\frac{1}{2}$ w			
R345	323-302	13.7 k	$\frac{1}{2}$ w	Prec	1%	
R346	323-385	100 k	$\frac{1}{2}$ w	Prec	1%	
R347	323-402	150 k	$\frac{1}{2}$ w	Prec	1%	
R348	316-101	100 Ω	$\frac{1}{4}$ w			
R349	302-122	1.2 k	$\frac{1}{2}$ w			
R355	301-224	220 k	$\frac{1}{2}$ w		5%	
R357	323-321	21.5 k	$\frac{1}{2}$ w	Prec	1%	
R358	323-426	267 k	$\frac{1}{2}$ w	Prec	1%	
R359	301-334	330 k	$\frac{1}{2}$ w		5%	
R360	316-222	2.2 k	$\frac{1}{4}$ w			
R361	323-243	2.32 k	$\frac{1}{2}$ w	Prec	1%	
R362	308-268	22 k	5 w	WW	1%	
R363	324-343	36.5 k	1 w	Prec	1%	
R364	301-303	30 k	$\frac{1}{2}$ w		5%	
R365	301-274	270 k	$\frac{1}{2}$ w		5%	
R366	316-102	1 k	$\frac{1}{4}$ w			
R367	316-182	1.8 k	$\frac{1}{4}$ w			
R368	316-336	33 meg	$\frac{1}{4}$ w			

Parts List—Type 547

Resistors (Cont'd)

Ckt. No.	Tektronix Part No.		Description			S/N Range
R369	316-182	1.8 k	1/4 w			
R370	301-472	4.7 k	1/2 w			5%
R371	302-472	4.7 k	1/2 w			
R372	302-274	270 k	1/2 w			
R373	316-470	47 Ω	1/4 w			
R374	323-353	46.4 k	1/2 w	Prec		1%
R375	323-330	26.7 k	1/2 w	Prec		1%
R376	323-356	49.9 k	1/2 w	Prec		1%
R377	321-0193-00	1 k	1/8 w	Prec		1%
R380	302-0473-00	47 k	1/2 w			X5680-up X1880-up
R381	316-470	47 Ω	1/4 w			
R382	316-101	100 Ω	1/4 w			
R383	302-104	100 k	1/2 w			
R384	316-820	82 Ω	1/4 w			
R390	323-373	75 k	1/2 w	Prec		1%
R391	316-470	47 Ω	1/4 w			
R392	316-101	100 Ω	1/4 w			
R393	302-472	4.7 k	1/2 w			
R394	316-101	100 Ω	1/4 w			
R397	307-106	4.7 Ω	1/4 w			5%
R398	316-101	100 Ω	1/4 w			
R399	316-101	100 Ω	1/4 w			
R401	316-101	100 Ω	1/4 w			
R404	302-331	330 Ω	1/2 w			
R406	301-563	56 k	1/2 w			5%
R407	301-913	91 k	1/2 w			5%
R408	316-101	100 Ω	1/4 w			
R409	303-183	18 k	1 w			5%
R412	316-101	100 Ω	1/4 w			
R413	316-473	47 k	1/4 w			
R414	324-339	33.2 k	1 w			
R415	311-015	10 k		Var	Prec WW	1% DELAY STOP
R416	311-022	30 k		Var		DELAY TIME MULTIPLIER 1-10
R417	302-331	330 Ω	1/2 w			
R418	311-141	2 k		Var	WW	DELAY START
R419	308-268	22 k	5 w		WW	1%
R421	316-101	100 Ω	1/4 w			
R424	302-564	560 k	1/2 w			
R425	301-104	100 k	1/2 w			5%
R426	301-223	22 k	1/2 w			5%
R428	302-223	22 k	1/2 w			
R429	302-682	6.8 k	1/2 w			
R430	302-333	33 k	1/2 w			
R431	302-151	150 Ω	1/2 w			
R432	316-470	47 Ω	1/4 w			
R433	302-102	1 k	1/2 w			
R435	302-562	5.6 k	1/2 w			
R438	302-101	100 Ω	1/2 w			
R439	302-102	1 k	1/2 w			
R441	302-105	1 meg	1/2 w			
R443	302-823	82 k	1/2 w			
R444	302-104	100 k	1/2 w			
R446	302-102	1 k	1/2 w			
R448	302-103	10 k	1/2 w			

Resistors (Cont'd)

Ckt. No.	Tektronix Part No.		Description			S/N Range
R451	302-183	18 k	1/2 w			
R452	304-223	22 k	1 w			
R453	302-103	10 k	1/2 w			
R454	301-913	91 k	1/2 w			5%
R455	304-393	39 k	1 w			
R456	316-100	10 Ω	1/4 w			
R457	302-472	4.7 k	1/2 w			
R458	302-473	47 k	1/2 w			
R459	302-332	3.3 k	1/2 w			
R461	323-384	97.6 k	1/2 w		Prec	1%
R464	303-183	18 k	1 w			5%
R467	316-273	27 k	1/4 w			
R469	302-155	1.5 meg	1/2 w			
R470	311-153	10 k		Var		A SWEEP DC LEVEL
R471	323-382	93.1 k	1/2 w		Prec	1%
R474	303-183	18 k	1 w			5%
R475	302-104	100 k	1/2 w			
R477	316-273	27 k	1/4 w			
R479	302-155	1.5 meg	1/2 w			
R481	301-154	150 k	1/2 w			5%
R481	304-273	27 k	1 w			100-1159 1160-up
R483	301-434	430 k	1/2 w			5%
R484	311-028	2 x 100 k		Var		TRACE SEPARATION
R485	315-203	20 k	1/4 w			5%
R486	316-470	47 Ω	1/4 w			
R487	303-433	43 k	1 w			5%
R488	303-433	43 k	1 w			5%
R493	301-434	430 k	1/2 w			5%
R495	315-203	20 k	1/4 w			5%
R496	316-470	47 Ω	1/4 w			
R497	303-433	43 k	1 w			5%
R498	303-433	43 k	1 w			5%
R499	315-162	1.6 k	1/4 w			5%
R501	302-470	47 Ω	1/2 w			
R503C	323-611	900 k	1/2 w		Prec	1%
R503D	323-610	111 k	1/2 w		Prec	1%
R507	323-481	1 meg	1/2 w		Prec	1%
R508	316-102	1 k	1/4 w			
R509	306-333	33 k	2 w			
R510	301-201	200 Ω	1/2 w			5%
R511	Use 311-491	10 k		Var		VAR 10-1
R512	306-333	33 k	2 w			
R514	316-101	100 Ω	1/4 w			
R516	302-332	3.3 k	1/2 w			
R517	302-224	220 k	1/2 w			
R519	311-026	100 k		Var		EXT HORIZ DC BAL
R522	305-183	18 k	2 w			5%
R524	323-356	49.9 k	1/2 w		Prec	1%
R525	301-565	5.6 meg	1/2 w			5%
R526	302-101	100 Ω	1/2 w			
R530A	} 311-431	50 k		Var		HORIZ POSITION VERNIER
R530B		50 k				

Parts List—Type 547

Resistors (Cont'd)

Ckt. No.	Tektronix Part No.		Description			S/N Range
R531	323-369	68.1 k	1/2 w		Prec	1%
R532	301-274	270 k	1/2 w			5%
R533	323-452	499 k	1/2 w		Prec	1%
R534	304-123	12 k	1 w			
R535	316-390	39 Ω	1/4 w			
R538	302-123	12 k	1/2 w			
R539	303-753	75 k	1 w			5%
R540	304-822	8.2 k	1 w			
R541	316-101	100 Ω	1/4 w			
R542	301-303	30 k	1/2 w			5%
R543	306-393	39 k	2 w			
R544	311-172	2.5 k		Var		×10 CAL
R545	323-284	8.87 k	1/2 w		Prec	1%
R545	323-0281-00	8.25 k	1/2 w		Prec	1%
R547	302-104	100 k	1/2 w			100-5129
R550	302-823	82 k	1/2 w			5130-up
R553	323-295	11.5 k	1/2 w		Prec	1%
R554	308-211	12 k	5 w		WW	5%
R556	323-252	4.12 k	1/2 w		Prec	1%
R557C	323-662	4.28 k	1/2 w		Prec	1%
R557E	323-196	1.07 k	1/2 w		Prec	1%
R557F	301-182	1.8 k	1/2 w			5%
R557G	323-162	475 Ω	1/2 w		Prec	1%
R557H	301-122	1.2 k	1/2 w			5%
R558	302-104	100 k	1/2 w			
R561	302-104	100 k	1/2 w			
R562	302-0333-00	33 k	1/2 w			X5680-up
R563	323-281	8.25 k	1/2 w		Prec	1%
R564	308-211	12 k	5 w		WW	5%
R566	311-066	500 Ω	2 w	Var		×1 CAL
R568	302-473	47 k	1/2 w			
R569	311-026	100 k		Var		SWP/MAG REGIS
R570	316-470	47 Ω	1/4 w			
R571	308-266	5 k	5 w		WW	5%
R572	*310-600	18 k/4.5 k	7 w		WW	
R573	316-470	47 Ω	1/4 w			
R574	316-470	47 Ω	1/4 w			
R576	*310-601	30 k	8 w		WW	1%
R577	302-154	150 k	1/2 w			
R578	316-103	10 k	1/4 w			
R579	302-394	390 k	1/2 w			
R580	316-470	47 Ω	1/4 w			
R581	302-155	1.5 meg	1/2 w			
R582	*310-611	18 k/3.7 k/800 Ω	6 w		WW	
R583	316-470	47 Ω	1/4 w			
R584	316-470	47 Ω	1/4 w			
R585	306-224	220 k	2 w			

Resistors (Cont'd)

Ckt. No.	Tektronix Part No.		Description		S/N Range
R586	*310-601	30 k	8 w	WW	1%
R587	302-154	150 k	1/2 w		
R588	316-103	10 k	1/4 w		
R589	302-394	390 k	1/2 w		
R591	302-155	1.5 meg	1/2 w		
R592	302-102	1 k	1/2 w		
R594	302-104	100 k	1/2 w		
R595	302-563	56 k	1/2 w		
R597	316-470	47 Ω	1/4 w		
R598	304-103	10 k	1 w		
R599	302-473	47 k	1/2 w		
R601	308-229	4 k	5 w	WW	5%
R603	308-269	22 Ω	3 w	WW	5%
R605	311-377	25 Ω		WW	SCALE ILLUM
R608	302-333	33 k	1/2 w		
R610	302-104	100 k	1/2 w		
R615	324-369	68.1 k	1 w		
R616	311-015	10 k		Var	Prec
R617	324-356	49.9 k	1 w		1% —150 VOLTS
R618	302-104	100 k	1/2 w		1%
R621	302-102	1 k	1/2 w		
R623	302-474	470 k	1/2 w		
R625	302-104	100 k	1/2 w		
R628	302-275	2.7 meg	1/2 w		
R629	302-275	2.7 meg	1/2 w		
R631	302-102	1 k	1/2 w		
R632	316-470	47 Ω	1/4 w		
R634	302-105	1 meg	1/2 w		
R635	304-153	15 k	1 w		
R636	304-153	15 k	1 w		
R637	302-684	680 k	1/2 w		
R638	302-273	27 k	1/2 w		
R639	302-683	68 k	1/2 w		
R640	306-100	10 Ω	2 w		
R641	306-100	10 Ω	2 w		
R644	302-102	1 k	1/2 w		
R645	316-470	47 Ω	1/4 w		
R646	308-282	1.35 k	25 w	WW	5%
R647	308-282	1.35 k	25 w	WW	5%
R650	324-443	402 k	1 w	Prec	1%
R651	324-458	576 k	1 w	Prec	1%
R663	Use 301-185	1.8 meg	1/2 w		5%
R664	304-333	33 k	1 w		
R665	301-225	2.2 meg	1/2 w		5%
R666	301-226	22 meg	1/2 w		5%
R667	302-334	330 k	1/2 w		
R667	301-304	300 k	1/2 w		5%
R668	302-563	56 k	1/2 w		

Parts List—Type 547

Resistors (Cont'd)

Ckt. No.	Tektronix Part No.		Description			S/N Range
R669	302-393	39 k	1/2 w			
R670A	306-100	10 Ω	2 w			
R670B	306-100	10 Ω	2 w			
R671	308-155	800 Ω	25 w	WW	5%	
R673	308-147	750 Ω	25 w	WW	5%	
R674	302-102	1 k	1/2 w			
R675	303-470	47 Ω	1 w		5%	
R676	303-470	47 Ω	1 w		5%	
R677	Use 308-065	2 k	25 w	WW	5%	
R680	324-443	402 k	1 w	Prec	1%	
R681	324-601	264 k	1 w	Prec	1%	
R682	302-124	120 k	1/2 w			
R683	302-102	1 k	1/2 w			
R685	304-823	82 k	1 w			
R686	302-184	180 k	1/2 w			
R688	302-155	1.5 meg	1/2 w			
R689	302-225	2.2 meg	1/2 w			
R693	302-155	1.5 meg	1/2 w			
R694	302-473	47 k	1/2 w			
R697	302-824	820 k	1/2 w			
R698	302-274	270 k	1/2 w			
R699	302-473	47 k	1/2 w			
R700	306-100	10 Ω	2 w			
R701	306-100	10 Ω	2 w			
R703	303-470	47 Ω	1 w		5%	
R704	302-102	1 k	1/2 w			
R705	303-470	47 Ω	1 w		5%	
R706	Use 308-0282-00	1.35 k	25 w	WW	5%	
R707	308-102	1.25 k	25 w	WW	5%	
R710	324-467	715 k	1 w	Prec	1%	
R711	324-604	303 k	1 w	Prec	1%	
R712	302-154	150 k	1/2 w			
R723	302-105	1 meg	1/2 w			
R726	301-0204-00	200 k	1/2 w		5%	X7330-up
R727	302-105	1 meg	1/2 w			
R728	302-684	680 k	1/2 w			100-7329
R728	301-0474-00	470 k	1/2 w		5%	7330-up
R729	302-224	220 k	1/2 w			100-7329
R729	301-0224-00	220 k	1/2 w		5%	7330-up
R730	302-100	10 Ω	1/2 w			
R731	306-823	82 k	2 w			
R734	316-470	47 Ω	1/4 w			
R737	308-192	5 k	20 w	WW	5%	
R741	302-104	100 k	1/2 w			
R743	307-103	2.7 Ω	1/4 w		5%	
R744	307-103	2.7 Ω	1/4 w		5%	
R757	302-154	150 k	1/2 w			
R758	315-823	82 k	1/4 w		5%	

Resistors (Cont'd)

Ckt. No.	Tektronix Part No.		Description			S/N Range
R759	315-203	20 k	1/4 w		5%	
R760	316-470	47 Ω	1/4 w			
R761	315-472	4.7 k	1/4 w		5%	100-1727
R761	321-0258-00	4.75 k	1/8 w	Prec	1%	1728-up
R762	301-683	68 k	1/2 w		5%	100-1727
R762	323-0370-00	69.8 k	1/2 w	Prec	1%	1728-up
R763	302-185	1.8 meg	1/2 w			
R764	302-105	1 meg	1/2 w			
R765	302-474	470 k	1/2 w			
R766	316-470	47 Ω	1/4 w			
R767	304-122	1.2 k	1 w			
R768	308-286	8.2 k	3 w	WW	5%	
R769	316-101	100 Ω	1/4 w			
R771	323-097	100 Ω	1/2 w	Prec	1%	
R773	323-097	100 Ω	1/2 w	Prec	1%	
R774	324-097	100 Ω	1 w	Prec	1%	
R775	323-097	100 Ω	1/2 w	Prec	1%	
R777	307-103	2.7 Ω	1/4 w		5%	
R778†	311-407	2 x 10 Ω		Var	WW	TRACE ROTATION
R802	306-271	270 Ω	2 w			
R803	306-563	56 k	2 w			
R804	316-0104-00	100 k	1/4 w			X5830-up
R806	Use 302-0823-00	82 k	1/2 w			
R807	301-432	4.3 k	1/2 w		5%	
R814	302-474	470 k	1/2 w			
R820	302-333	33 k	1/2 w			
R821	301-225	2.2 meg	1/2 w		5%	
R822	302-333	33 k	1/2 w			
R824	305-755	7.5 meg	2 w		5%	
R825	305-755	7.5 meg	2 w		5%	
R826	311-450	1 meg		Var		INTENSITY 100-8139
R826	311-0450-01	1 meg		Var		INTENSITY 8140-up
R827	302-333	33 k	1/2 w			
R828	302-223	22 k	1/2 w			
R830	302-335	3.3 meg	1/2 w			
R831	306-183	18 k	2 w			
R832	302-101	100 Ω	1/2 w			
R836	316-105	1 meg	1/4 w			
R840	311-034	500 k		Var		HIGH VOLTAGE
R841	303-225	2.2 meg	1 w		5%	
R842	303-335	3.3 meg	1 w		5%	
R843	303-275	2.7 meg	1 w		5%	
R845	303-335	3.3 meg	1 w		5%	
R846	311-313	5 meg		Var		FOCUS 100-8139
R846	311-0313-01	5 meg		Var		FOCUS 8140-up
R847	302-474	470 k	1/2 w			
R853	302-103	10 k	1/2 w			
R857	302-273	27 k	1/2 w			

†Furnished as a unit with R864.

Parts List—Type 547

Resistors (Cont'd)

Ckt. No.	Tektronix Part No.		Description			S/N Range
R858	302-105	1 meg	1/2 w			
R859	302-471	470 Ω	1/2 w			
R861	311-026	100 k		Var		
R862	301-823	82 k	1/2 w			GEOMETRY
R862	323-395	127 k	1/2 w		Prec	5% 100-1009
R863	301-473	47 k	1/2 w			1% 1010-up
R863	323-356	49.9 k	1/2 w			5% 100-1009
R864†	311-407	50 k		Var	Prec WW	1% 1010-up
R931	302-154	150 k	1/2 w			ASTIGMATISM
R932	301-394	390 k	1/2 w			5%
R934	301-475	4.7 meg	1/2 w			5%
R935	302-103	10 k	1/2 w			
R936	302-102	1 k	1/2 w			
R938	302-102	1 k	1/2 w			
R939	302-221	220 Ω	1/2 w			
R941	302-221	220 Ω	1/2 w			
R943	311-141	2 k		Var	WW	CAL AMPL
R944	302-100	10 Ω	1/2 w			
R945	308-268	22 k	5 w		WW	1%
R948	315-0682-00	6.8 k	1/4 w			5% X3150-up
R949	302-274	270 k	1/2 w			
R950	323-289	10 k	1/2 w		Prec	1% 100-2889
R950	323-0709-01	10.048 k	1/2 w		Prec	1/2% 2890-up
R951	323-635	6.667 k	1/2 w		Prec	1% 100-2889
R951	323-0708-01	6.628 k	1/2 w		Prec	1/2% 2890-up
R952	323-634	1.789 k	1/2 w		Prec	1% 100-2889
R952	323-0707-01	1.728 k	1/2 w		Prec	1/2% 2890-up
R953	323-633	801 Ω	1/2 w		Prec	1% 100-2889
R953	323-0706-01	800 Ω	1/2 w		Prec	1/2% 2890-up
R954	323-632	452 Ω	1/2 w		Prec	1% 100-2889
R954	323-0705-01	452 Ω	1/2 w		Prec	1/2% 2890-14130
R954	323-0632-01	452 Ω	1/2 w		Prec	1/2% 14131-up
R955	323-631	146.1 Ω	1/2 w		Prec	1% 100-2889
R955	323-0704-01	146 Ω	1/2 w		Prec	1/2% 2890-up
R956	323-630	72.4 Ω	1/2 w		Prec	1% 100-2889
R956	323-0703-01	72.4 Ω	1/2 w		Prec	1/2% 2890-14130
R956	323-0630-01	72.4 Ω	1/2 w		Prec	1/2% 14131-up
R957	323-629	43.1 Ω	1/2 w		Prec	1% 100-2889
R957	323-0702-01	43.1 Ω	1/2 w		Prec	1/2% 2890-14130
R957	323-0629-01	43.1 Ω	1/2 w		Prec	1/2% 14131-up
R958	323-628	28.6 Ω	1/2 w		Prec	1% 100-2889
R958	323-0701-01	28.6 Ω	1/2 w		Prec	1/2% 2890-14130
R958	323-0628-01	28.6 Ω	1/2 w		Prec	1/2% 14131-up
R960	323-636	50 k	1/2 w		Prec	1% 100-2889
R962	323-627	21.4 Ω	1/2 w		Prec	1% 100-2889
R962	323-0700-01	21.4 Ω	1/2 w		Prec	1/2% 2890-14130
R962	323-0627-01	21.4 Ω	1/2 w		Prec	1/2% 14131-up
R964	323-638	50 k	1/2 w		Prec	1/4% 100-10199
R964	323-0638-06	50 k	1/2 w		Prec	1/4% 10200-up
R965	323-637	50 Ω	1/2 w		Prec	1/4% 100-8849
R965	323-0637-06	50 Ω	1/2 w		Prec	1/4% 8850-up
R969	308-242	.25 Ω	5 w		WW	5%

†Furnished as a unit with R778.

Resistors (Cont'd)

Ckt. No.	Tektronix Part No.	Description	S/N Range
R1000	316-820	82 Ω 1/4 w	
R1001	315-220	22 Ω 1/4 w	5%
R1002	301-101	100 Ω 1/2 w	5%
R1003	305-682	6.8 k 2 w	5%
R1004	311-086	2.5 k	Var VERT DC BAL 100-6729
R1004	311-0629-00	3 k	Var VERT DC BAL 6730-up
R1011	315-220	22 Ω 1/4 w	5%
R1013	305-682	6.8 k 2 w	5%
R1014	301-131	130 Ω 1/2 w	5%
R1015	315-131	130 Ω 1/4 w	5%
R1016	315-300	30 Ω 1/4 w	5%
R1017	311-258	100 Ω	Var VERT GAIN 100-4749
R1017	311-0097-00	200 Ω	Var VERT GAIN 4750-up
R1018	305-273	27 k 2 w	5%
R1019	308-002	1.5 k 5 w	WW 5%
R1020	316-331	330 Ω 1/4 w	X940-up
R1024	301-131	130 Ω 1/2 w	5%
R1025	315-131	130 Ω 1/4 w	5%
R1026	315-300	30 Ω 1/4 w	5%
R1027	315-121	120 Ω 1/4 w	5% 100-1009
R1027	315-471	470 Ω 1/4 w	5% 1010-up
R1031	315-512	5.1 k 1/4 w	5%
R1032	322-092	88.7 Ω 1/4 w	Prec 1%
R1034	315-100	10 Ω 1/4 w	5%
R1038	301-821	820 Ω 1/2 w	5%
R1041	315-512	5.1 k 1/4 w	5%
R1042	322-092	88.7 Ω 1/4 w	Prec 1%
R1048	301-821	820 Ω 1/2 w	5%
R1051	321-117	162 Ω 1/8 w	Prec 1%
R1061	321-117	162 Ω 1/8 w	Prec 1%
R1069	315-361	360 Ω 1/4 w	5%
R1071	315-360	36 Ω 1/4 w	5%
R1072	323-105	121 Ω 1/2 w	Prec 1%
R1073	301-331	330 Ω 1/2 w	5%
R1074	321-073	56.2 Ω 1/8 w	Prec 1%
R1076	311-442	250 Ω	Var 100-15279
R1076	311-1223-00	250 Ω	Var 15280-up
R1077	315-163	16 k 1/4 w	5% 100-10729
R1077	311-0614-00	30 k	Var 10730-up
R1082	323-105	121 Ω 1/2 w	Prec 1%
R1083	301-331	330 Ω 1/2 w	5%
R1084	321-073	56.2 Ω 1/8 w	Prec 5%
R1087	304-122	1.2 k 1 w	
R1088	305-681	680 Ω 2 w	5%
R1089	308-296	1.2 k 5 w	WW 5%
R1091	311-0613-00	100 k	Var X10730-up
R1104	301-270	27 Ω 1/2 w	5%
R1105	323-102	113 Ω 1/2 w	Prec 1%
R1106	311-442	250 Ω	Var 100-15279
R1106	311-1223-00	250 Ω	Var 15280-up
R1108	*310-603	600 Ω /300 Ω 3 w	WW 2%
R1109	305-0243-00	24 k 2 w	5% X2340-up
R1113	315-100	10 Ω 1/4 w	5%
R1114	*310-602	1 k 8 w	WW 1%
R1118	308-232	320 Ω 5 w	WW 5%
R1124	301-270	27 Ω 1/2 w	5%

Parts List—Type 547

Resistors (Cont'd)

Ckt. No.	Tektronix Part No.		Description			S/N Range
R1126	321-204	1.3 k	1/8 w	Prec	1%	100-10729
R1126	321-0201-00	1.21 k	1/8 w	Prec	1%	10730-up
R1129	308-283	800 Ω	10 w	WW	5%	
R1132	315-100	10 Ω	1/4 w		5%	
R1134	*310-602	1 k	8 w	WW	1%	
R1141	322-092	88.7 Ω	1/4 w	Prec	1%	
R1142	315-331	330 Ω	1/4 w		5%	
R1144	301-681	680 Ω	1/2 w		5%	
R1151	322-092	88.7 Ω	1/4 w	Prec	1%	
R1152	315-331	330 Ω	1/4 w		5%	
R1153	315-100	10 Ω	1/4 w		5%	
R1154	301-681	680 Ω	1/2 w		5%	
R1156	315-820	82 Ω	1/4 w		5%	
R1157	315-361	360 Ω	1/4 w		5%	
R1161	315-221	220 Ω	1/4 w		5%	
R1163	308-258	6 k	3 w	WW	5%	
R1165	315-820	82 Ω	1/4 w		5%	
R1166	302-221	220 Ω	1/2 w			
R1169	302-105	1 meg	1/2 w			
R1173	308-258	6 k	3 w	WW	5%	
R1175	315-820	82 k	1/4 w		5%	
R1181	315-105	1 meg	1/4 w		5%	
R1184	301-334	330 k	1/2 w		5%	
R1187	301-334	330 k	1/2 w		5%	100-11889
R1187	323-0431-00	301 k	1/2 w	Prec	1%	11890-up
R1191	315-105	1 meg	1/4 w		5%	
R1194	301-334	330 k	1/2 w		5%	

Switches

	unwired	wired				
SW1	260-495		Lever	SOURCE		
SW5	260-494	*262-598 (B Triggering)	Lever	COUPLING		
SW10	260-542		Lever	SLOPE		
SW75	260-493		Lever	MODE		
SW15†	311-426		Lever	PULL FOR X10 RANGE INCREASE		
SW90	260-531	*262-596	Rotary	B TIME/CM OR DELAY TIME		100-5309
SW90	260-0531-00	*262-0596-01	Rotary	B TIME/CM OR DELAY TIME		5310-up
SW90Z††	311-391					
SW201	260-495	*262-597 (A Triggering)	Lever	SOURCE		
SW205	260-494		Lever	COUPLING		
SW210	260-542		Lever	SLOPE		
SW375	260-493		Lever	MODE		
SW215†††	311-426		Lever	PULL FOR X10 RANGE INCREASE		
SW290	260-530	*262-595	Rotary	A TIME/CM		100-5309
SW290	260-0530-00	*262-0595-01	Rotary	A TIME/CM		5310-up
SW290Z††††	311-391					
SW369	260-496	*262-602	Lever	SINGLE SWEEP		
SW135	260-516		Push	RESET		
SW530	260-535	*262-601	Rotary	HORIZONTAL DISPLAY REAR		100-4269
SW530	260-0796-00	*262-0601-00	Rotary	HORIZONTAL DISPLAY REAR		4270-up
SW557	260-534	*262-600	Rotary	HORIZONTAL DISPLAY FRONT		
SW601	260-199		Toggle	POWER ON		100-7979
SW601	260-0785-00		Toggle	POWER ON		7980-15300
SW601	260-0276-00		Toggle	POWER ON		15301-up
SW602†††††						X7980-up

†Furnished as a unit with R15.

††Furnished as a unit with R90Z.

†††Furnished as a unit with R215.

††††Furnished as a unit with R290Z.

†††††See Mechanical Parts List, Line Voltage Selector Body

Switches (Cont'd)

Ckt. No.	Tektronix Part No.	Description	S/N Range
SW673	260-516	Push	
SW858	260-209	Toggle	
SW950	260-536 Use *262-0731-00	Rotary	
SW1000	260-601	Slide	
TK601	260-336	Thermal Cutout	150° F ±5° F

Transformers

T52	Use *120-0323-01	Toroid 2T-8T Bifilar	100-6739
T52	*120-0500-00	Toroid 2T-12T Bifilar	6740-up
T252	Use *120-0323-01	Toroid 2T-8T Bifilar	100-6739
T252	*120-0500-00	Toroid 2T-12T Bifilar	6740-up
T601	*120-307	L.V. Power	100-7979
T601	*120-0521-00	L.V. Power	7980-up
T801	*120-308	H.V. Power	
T1030	*120-341	Toroid 3T Bifilar	
T1104	276-541	Core, Ferrite	

Electron Tubes

V24	154-187	6DJ8	100-6239
V24	*157-0122-00	6DJ8, Checked	6240-7979
V24	*157-0125-00	6DJ8, Checked	7980-up
V91	154-040	12AU6	100-4169
V91	154-0040-05	8426	4170-up
V93	154-187	6DJ8	
V145	154-187	6DJ8	
V193	154-187	6DJ8	
V224	154-187	6DJ8	100-6239
V224	*157-0122-00	6DJ8, Checked	6240-7979
V224	*157-0125-00	6DJ8, Checked	7980-up
V291	154-022	6AU6	
V293	154-187	6DJ8	
V345	154-187	6DJ8	
V393	154-187	6DJ8	
V404	154-187	6DJ8	
V494	154-187	6DJ8	
V514	154-187	6DJ8	
V574	154-187	6DJ8	
V584	154-187	6DJ8	
V589	154-146	6197	
V609	154-291	OG3	
V624	154-043	12AX7	
V634	154-022	6AU6	
V637	154-202	6CW5	
V647	154-202	6CW5	
V664	154-414	6BY8	
V677	154-056	6080	

Parts List—Type 547

Electron Tubes (Cont'd)

Ckt. No.	Tektronix Part No.	Description	S/N Range
V684	154-043	12AX7	
V694	154-022	6AU6	
V707	154-056	6080	
V724	154-022	6AU6	
V737	154-202	6CW5	
V764	154-187	6DJ8	
V800	154-021	6AU5	
V814	154-041	12AU7	
V822	154-051	5642	
V832	154-051	5642	
V842	154-051	5642	
V852	154-051	5642	
V859†	*154-0478-00	T5470-31-2 CRT Standard Phosphor	100-2069
V859	*154-0478-00	T5470-31-2 CRT Standard Phosphor	2070-9999
V859	*154-0568-00	T5471-31-2 CRT Standard Phosphor	10,000-up
V862	154-051	5642	
V935	154-041	12AU7	
V945	154-022	6AU6	
V1003	154-039	12AT7	
V1003	*157-0118-00	12AT7, checked	100-6729
V1184	154-043	12AX7	6730-up

CRT Optional Phosphors

*154-0568-01	P2
*154-0568-02	P7
*154-0568-03	P11

† S/N 100-2069 add *050-0246 kit.

IMPORTANT:

All circuit voltages were obtained with a 20,000 Ω /Volt VOM.

All readings are in volts. The voltages were measured with respect to ground unless otherwise indicated by the use of arrows to point out voltage drop.

Waveforms were obtained using a Type 530-Series Oscilloscope with a Type L Plug-In Unit and 10X attenuator probe. An equivalent oscilloscope having a vertical passband of dc to 10 mc or better and equal sensitivity can be used as a test oscilloscope.

Waveform dc levels with respect to ground are indicated at the right side of waveform; measured when test oscilloscope AC-DC switch was set to DC.

Waveforms were photographed with test oscilloscope AC-DC switch set to AC; vertical deflection factor and Time/Cm switch set to those settings indicated adjacent to waveforms.

In most cases +Ext. AC triggering on the Type 547 1-kc AMPLITUDE CALIBRATOR signal was used. Exceptions: -Int., +Int. and +Line (60 cps) triggering modes were also used; these modes, if used, are indicated above the waveforms.

NOTE

Number of cycles displayed by waveform when calibrator signal was used as a trigger source depends mostly on the signal repetition rate. Though +Ext. triggering was used, a time difference of 1 msec can occur between waveforms because the test oscilloscope can trigger on a different cycle than the Type 547 and vice versa.

Voltage and waveform measurements are not absolute. They may vary between instruments due to normal manufacturing tolerances, and transistor and vacuum tube characteristics.

The plug-in unit used in the Type 547 Oscilloscope during the voltage and waveform measurements is a Type TU-7 Test Unit. Its front-panel control settings and other conditions are as follows:

Input Signal	None
Position	Centered
	(Exception: See Vertical Amplifier schematic diagram)
Test Function	Low Load

Any letter-series or 1-series plug-in unit or the TU-2 can be used in place of the Type TU-7 when troubleshooting the Type 547.

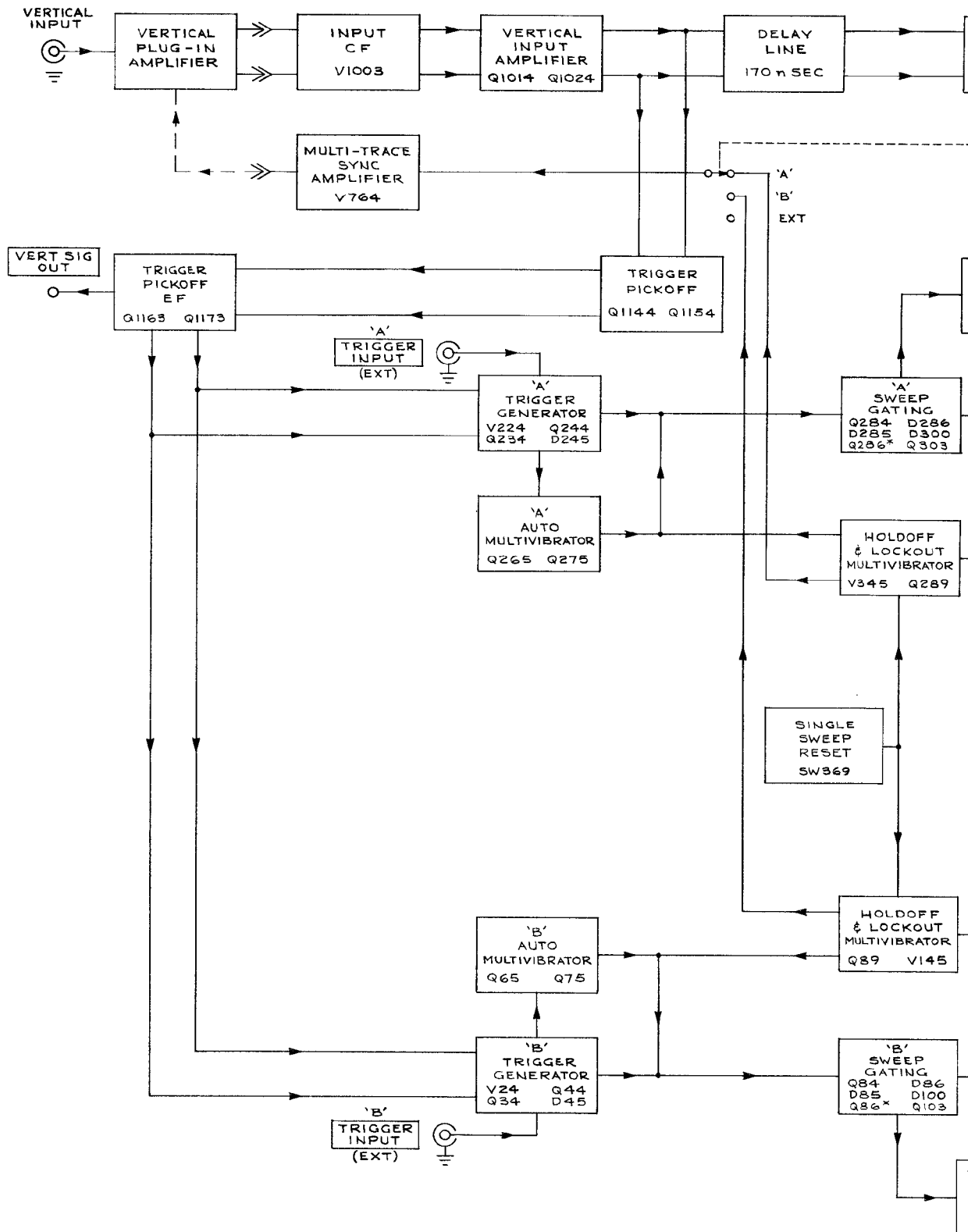

* DENOTES PRESENCE IN UNITS ABOVE SN 12480. FOR UNITS BELOW SN 12480, THE COMPONENT IS ABSENT.

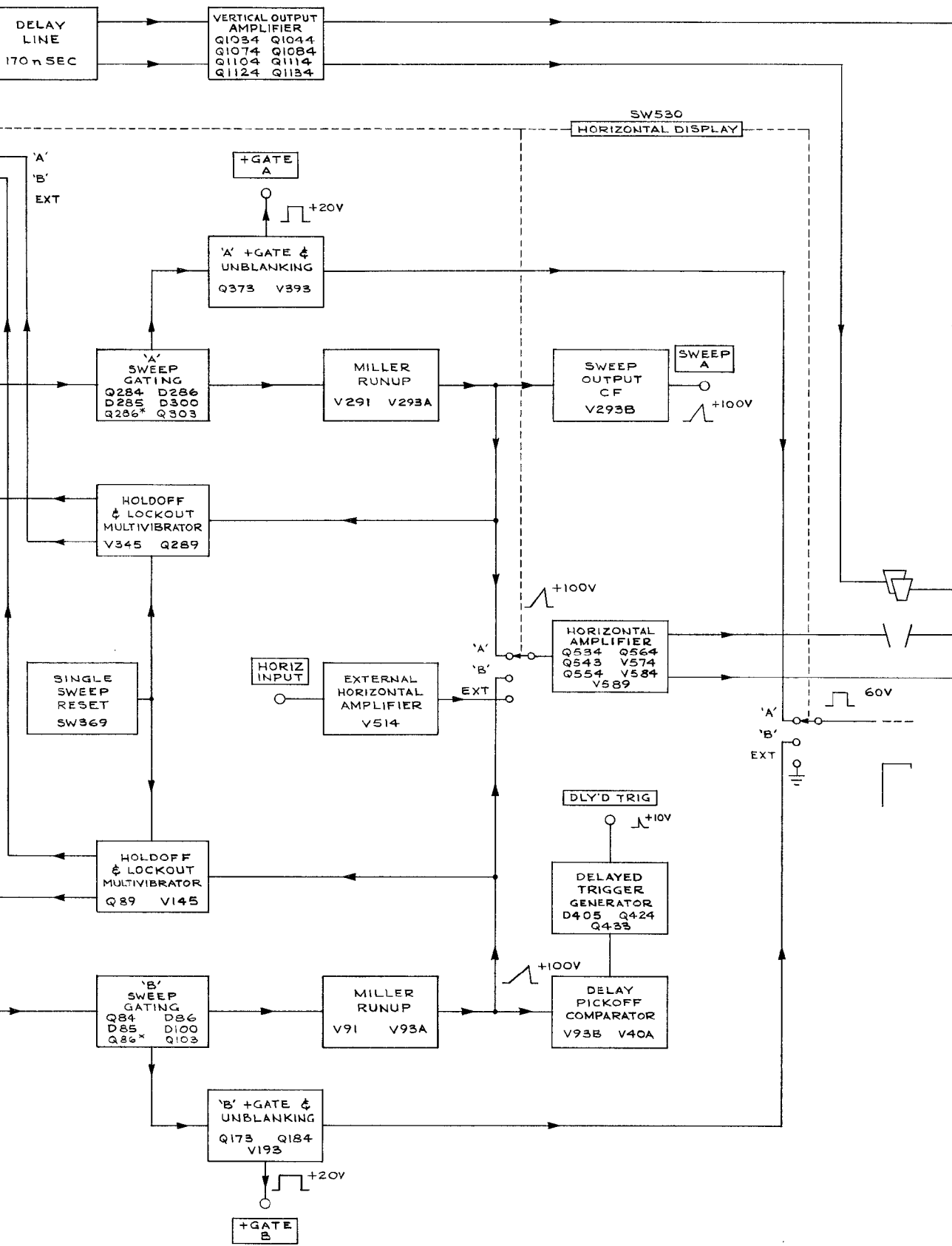

MRH
969

'A' OR 'B' OR EXTERNAL MODE

B

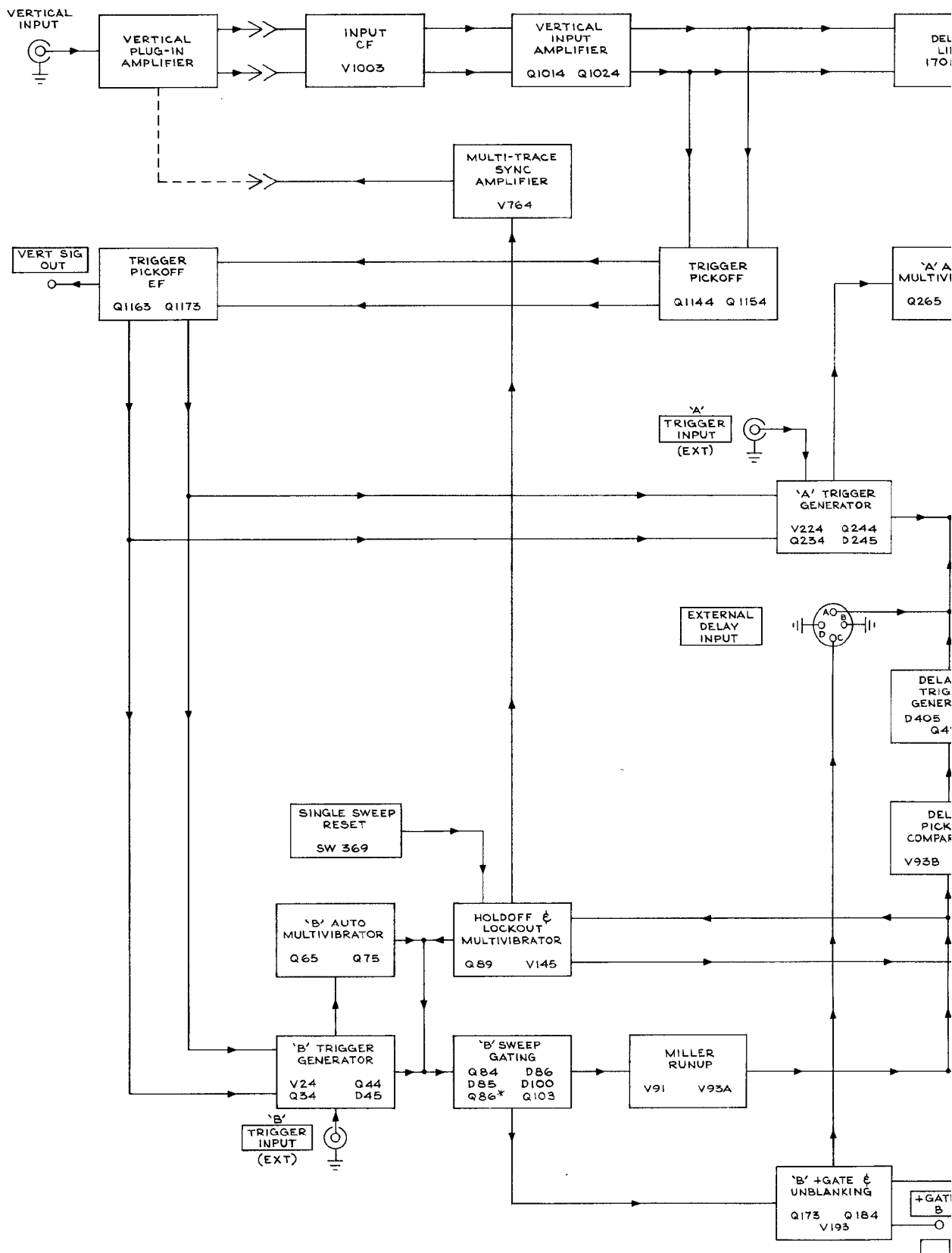

TYPE 547 OSCILLOSCOPE

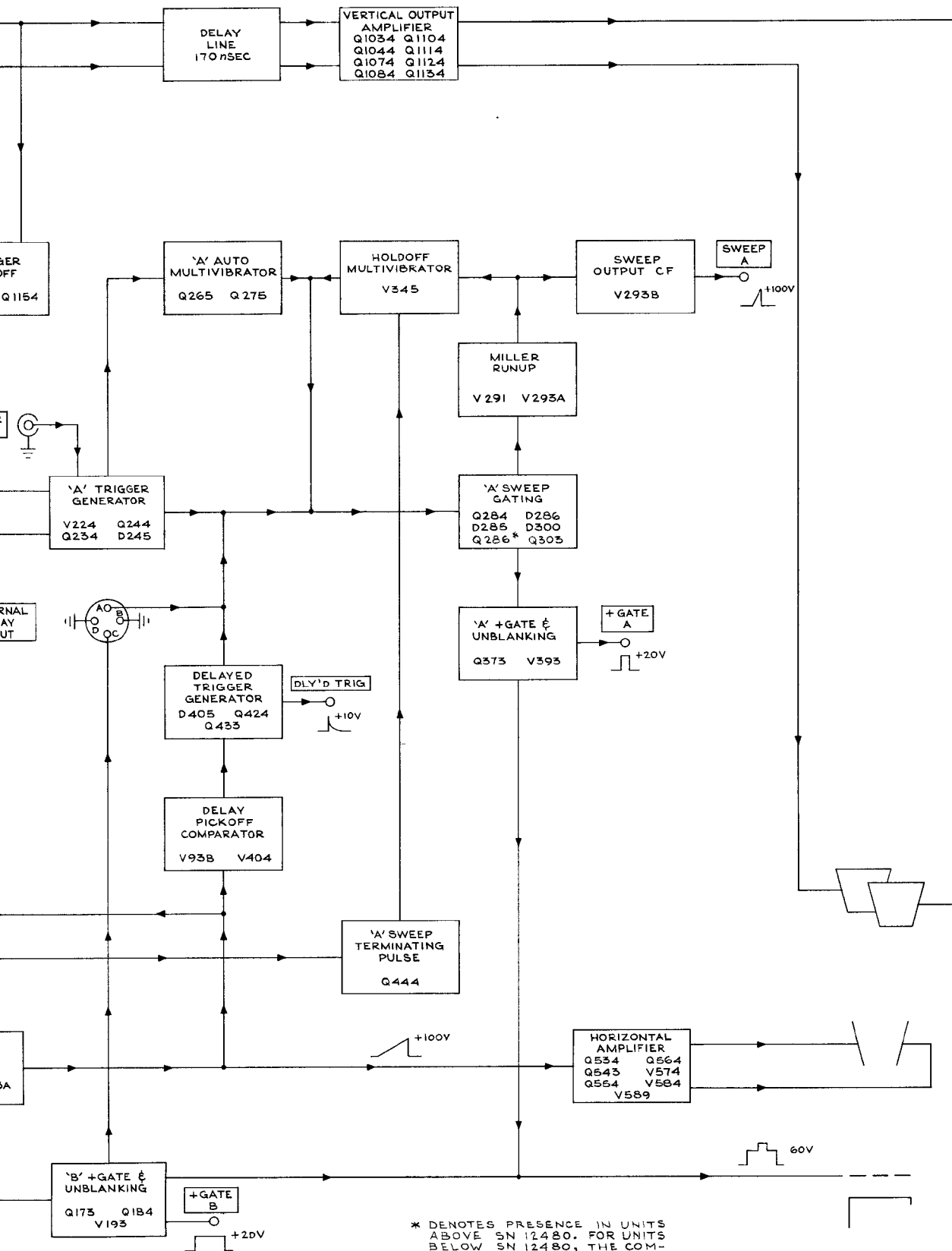

* DENOTES PRESENCE IN UNITS ABOVE SN 12480. FOR UNITS BELOW SN 12480, THE COMPONENT IS ABSENT.

B

'B' INTENSIFIED BY 'A' MODE

DON
969

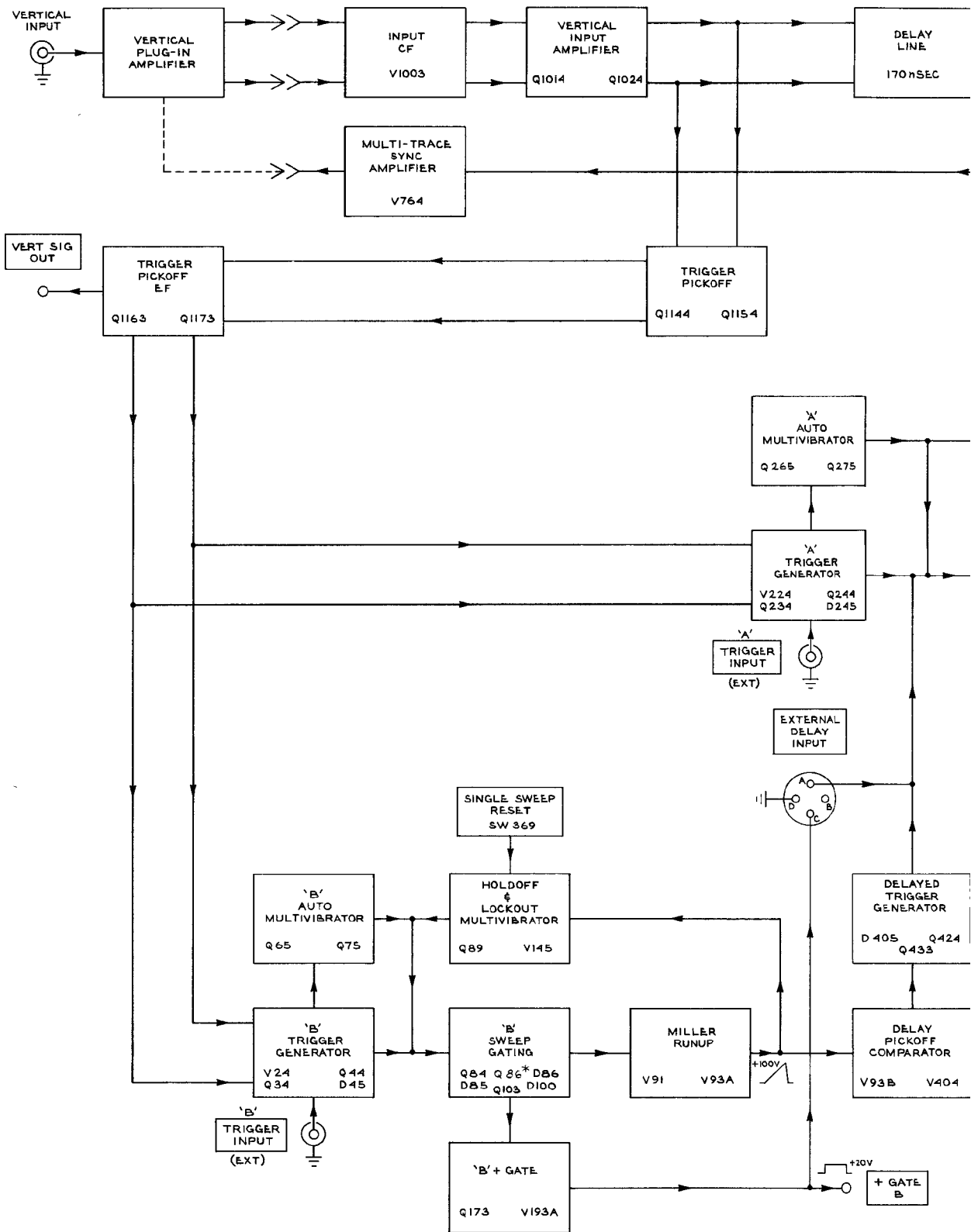

TYPE 547 OSCILLOSCOPE

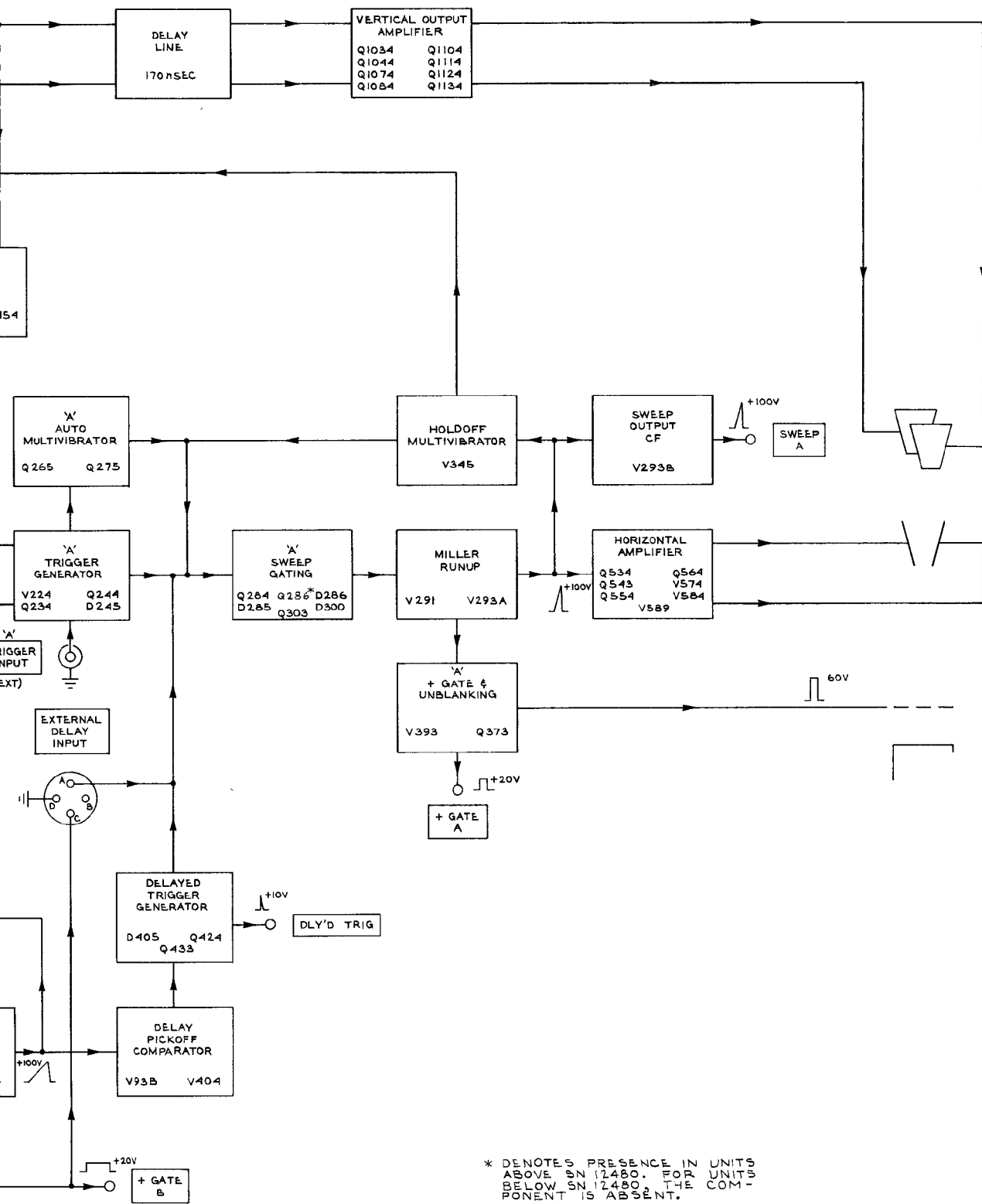

CMD
569

'A' DELAYED MODE

B

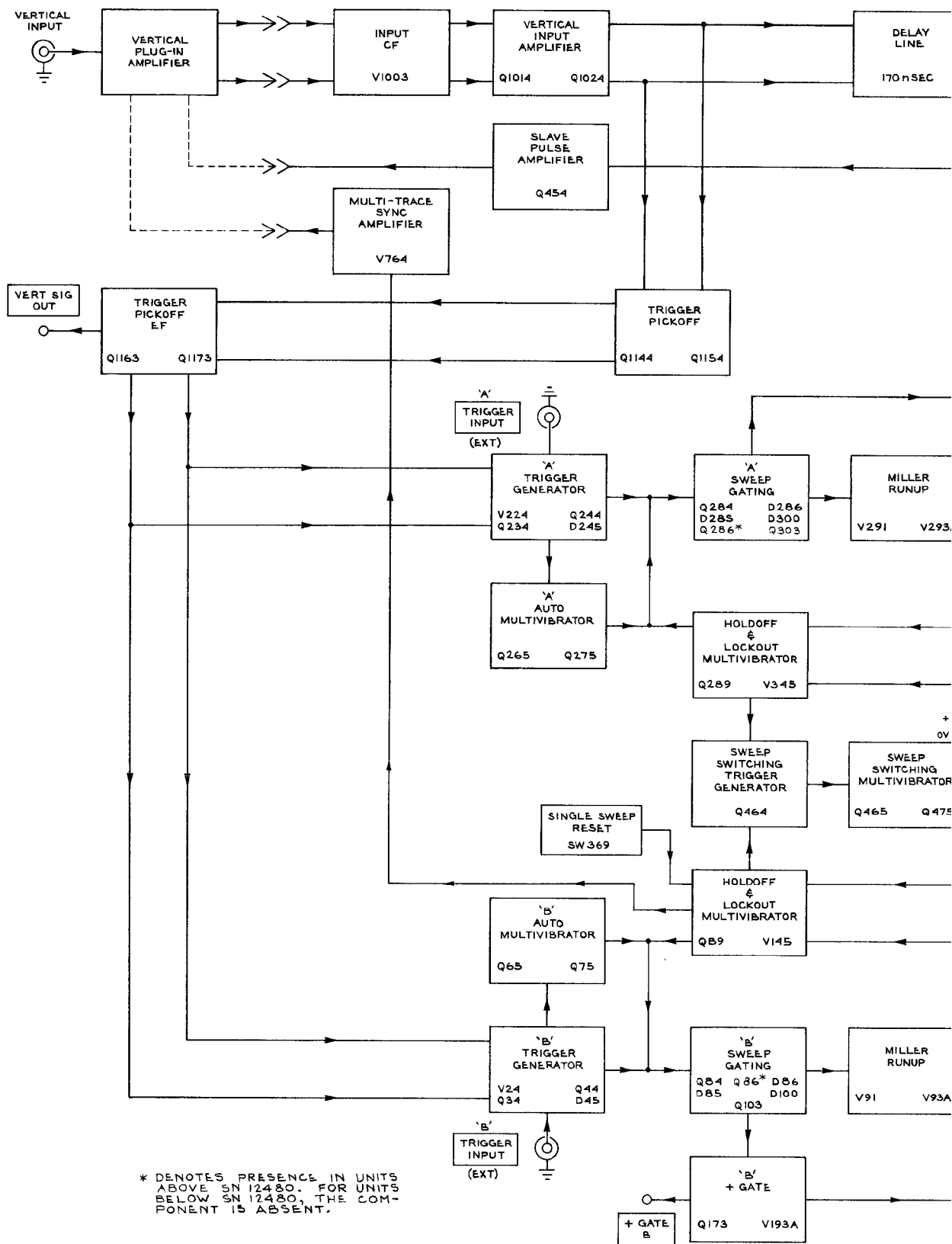

TYPE 547 OSCILLOSCOPE

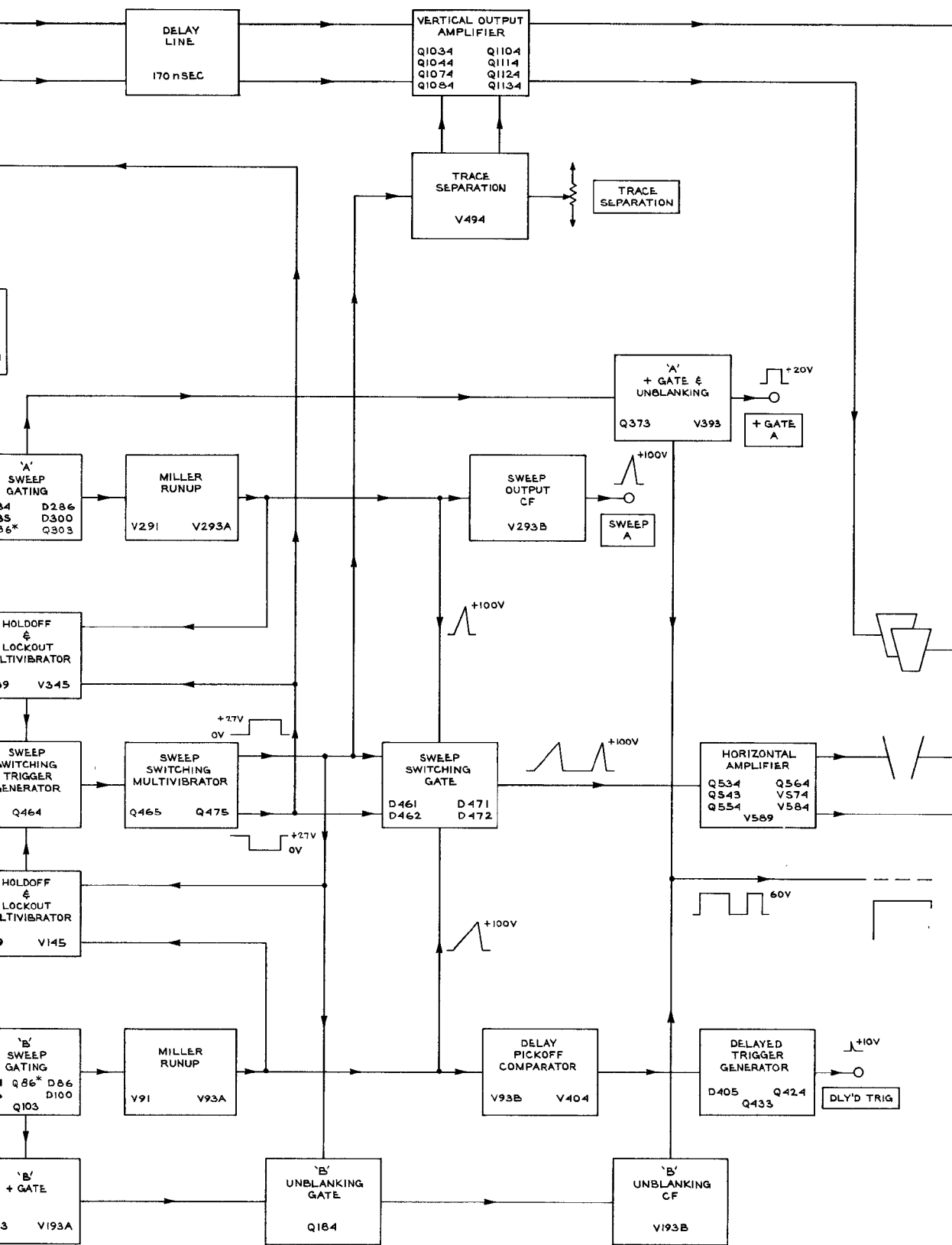

B

CMD
969

'A' ALTERNATE WITH 'B' MODE

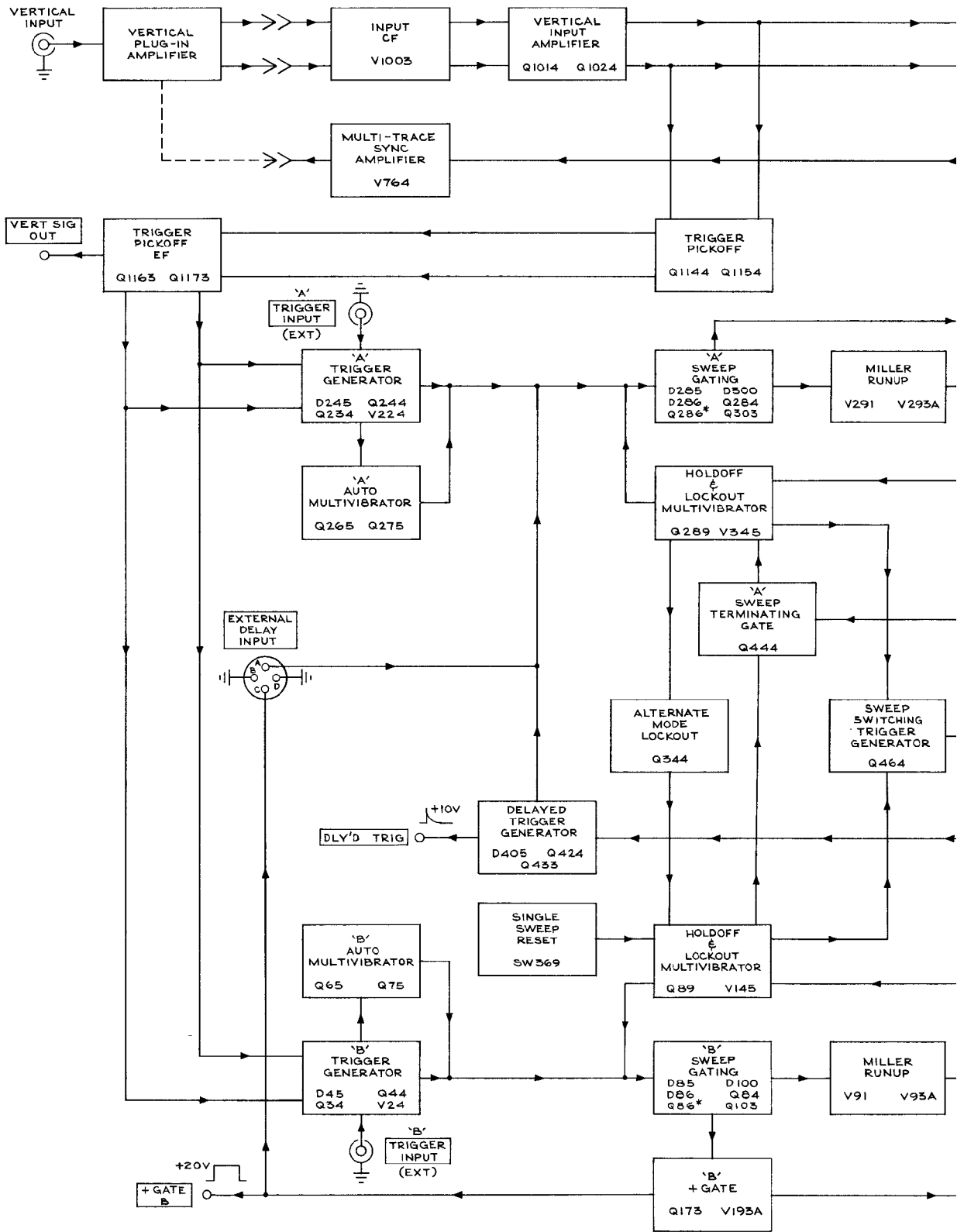

TYPE 547 OSCILLOSCOPE

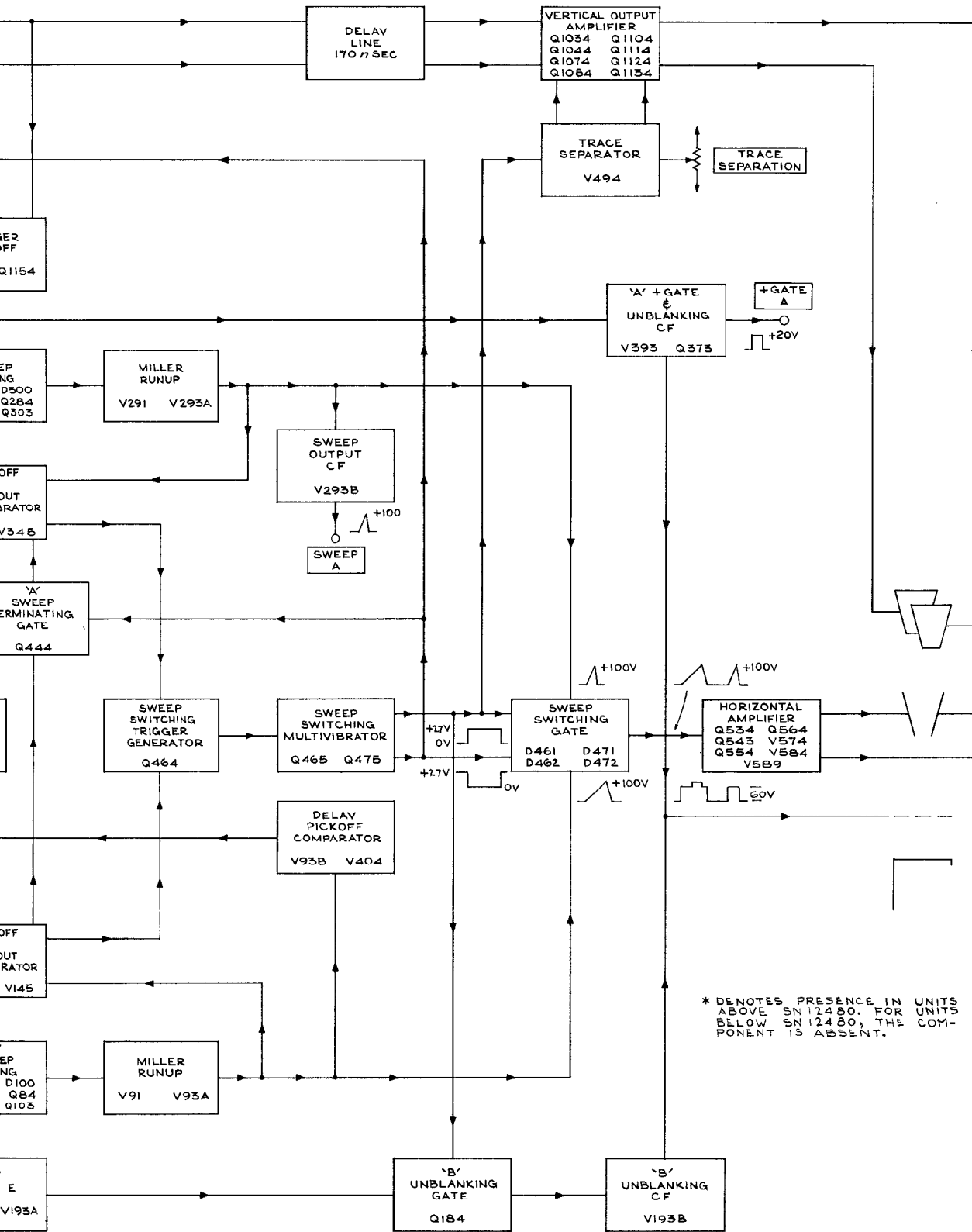

* DENOTES PRESENCE IN UNITS ABOVE SN 12480. FOR UNITS BELOW SN 12480, THE COMPONENT IS ABSENT.

DON
969

B 'B' INTENS BY 'A' ALTERNATE WITH 'A' DLY'D MODE

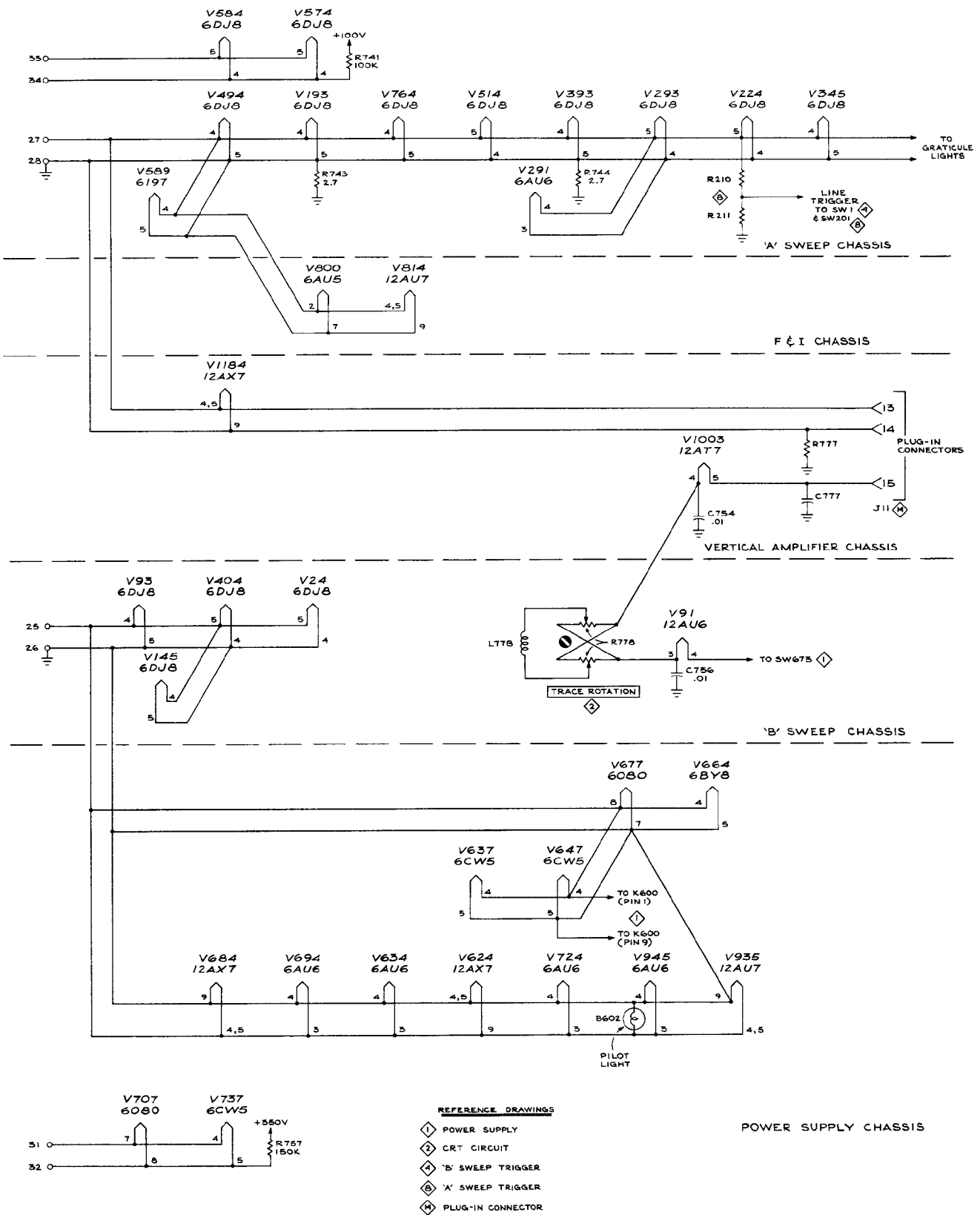

TYPE 547 OSCILLOSCOPE

HEATER WIRING DIAGRAM
SN 7980-UP

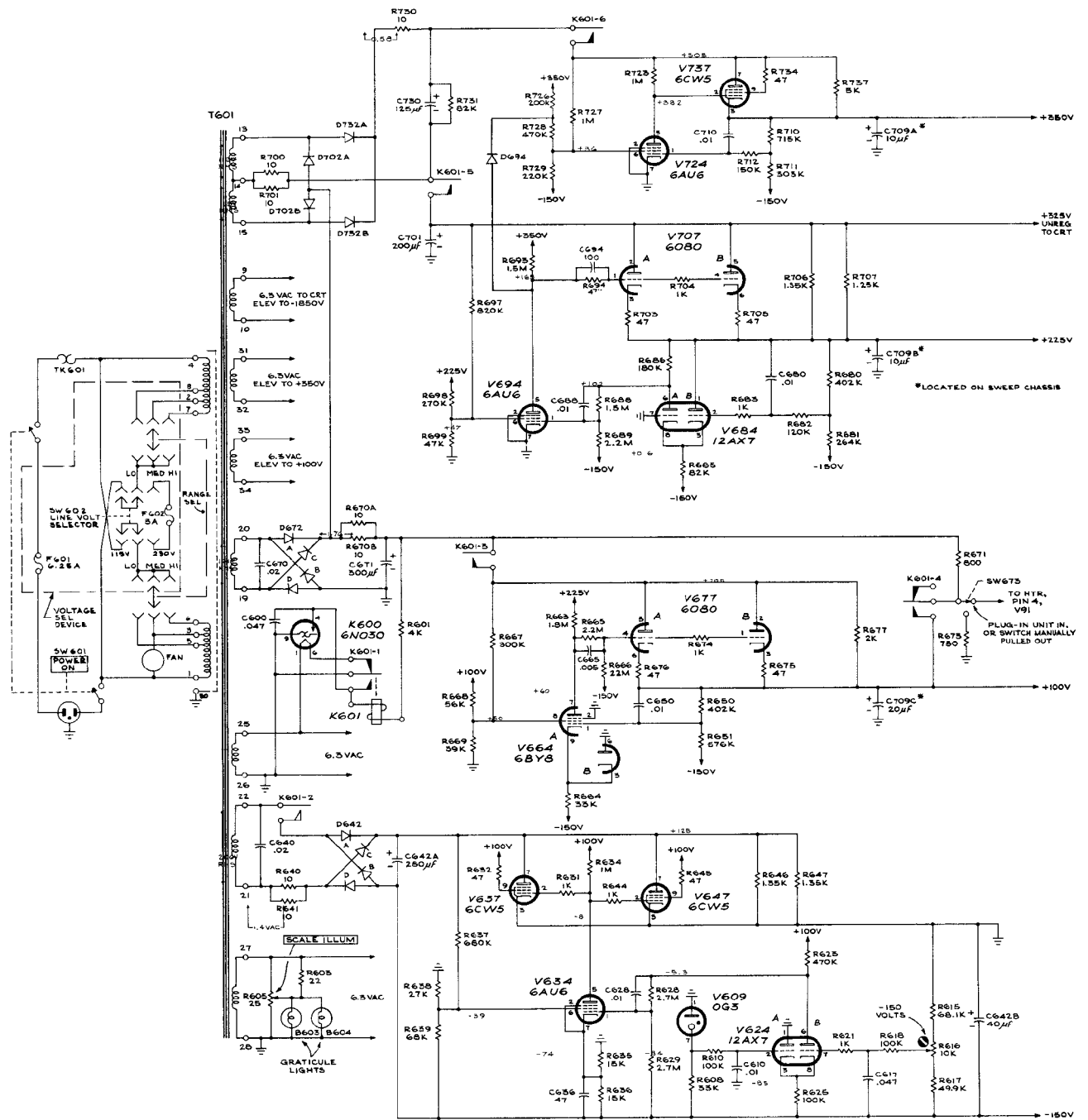

POWER SUPPLY

VOLTAGE READINGS WERE OBTAINED under the following conditions:

LINE VOLTAGE 115 VAC (or Design Center)

INPUT SIGNAL None

'A' AND 'B' TRIGGER INPUT Signal None

'A' AND 'B' TRIGGERING LEVEL ccw

'A' AND 'B' TRIGGERING MODE TRIG

'A' AND 'B' TRIGGERING SOURCE EXT

AMPLITUDE CALIBRATOR OFF

POWER ON

Also see IMPORTANT note on "A or B or External Mode" Block diagram.

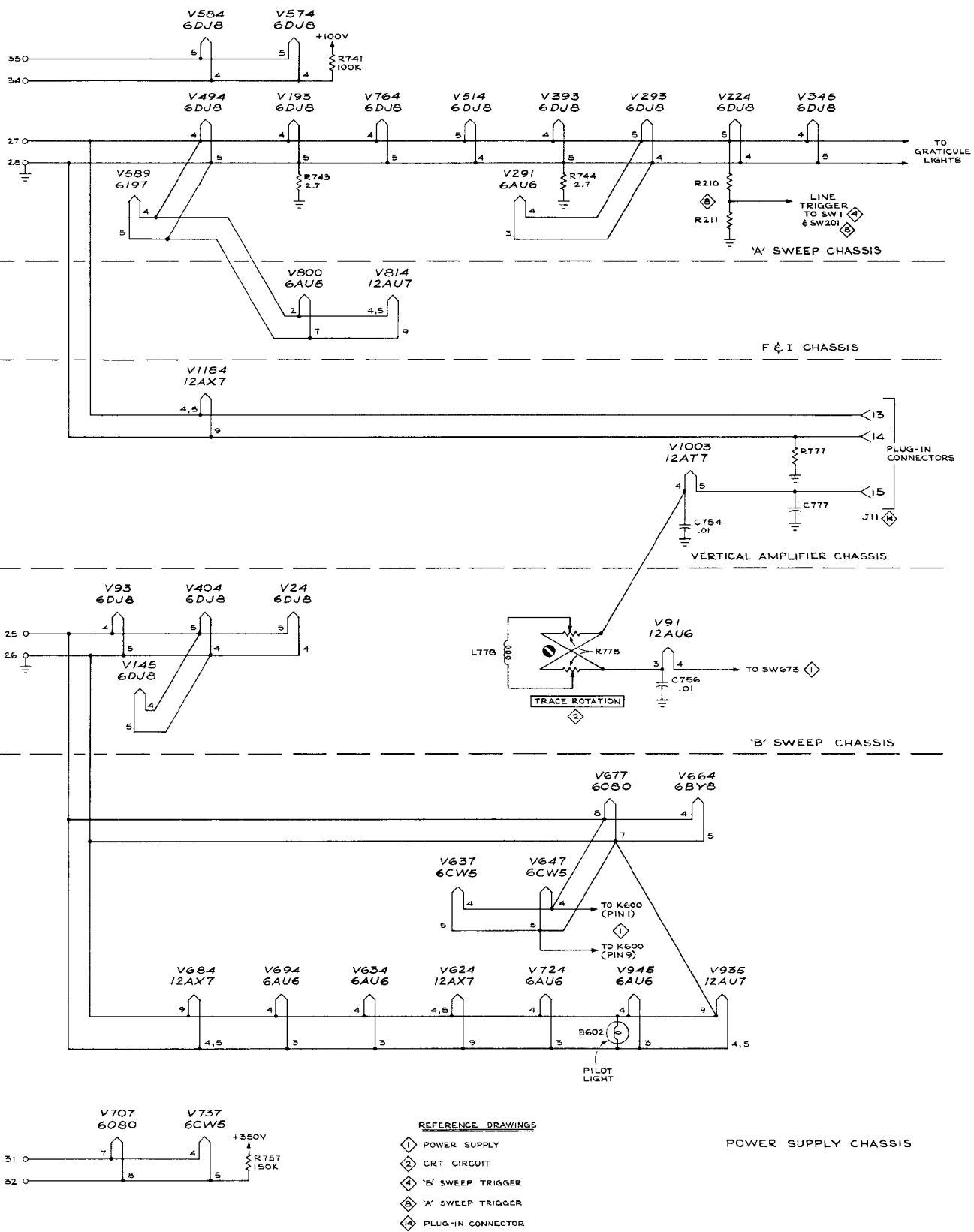

TYPE 547 OSCILLOSCOPE

HEATER WIRING DIAGRAM

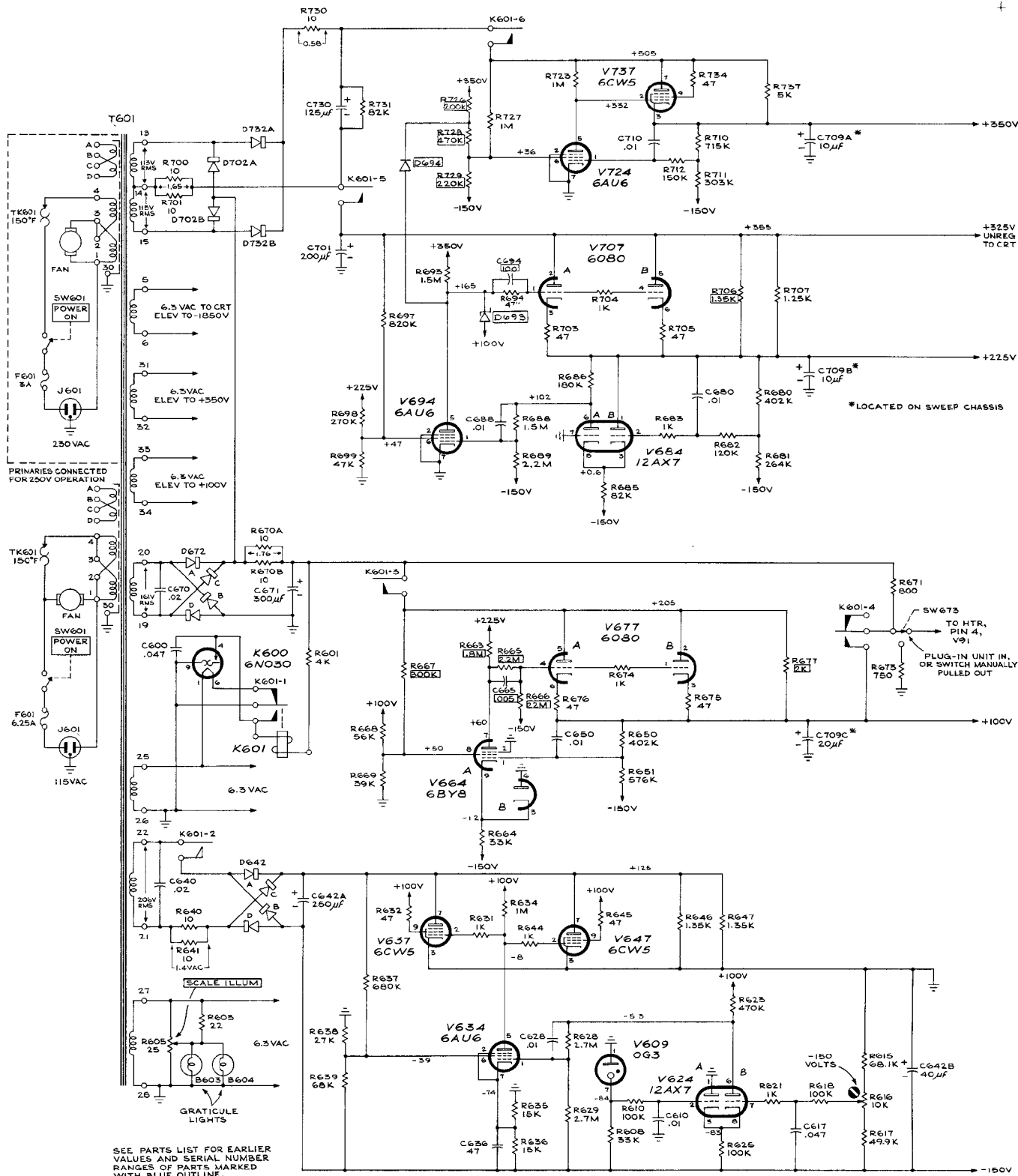

SEE PARTS LIST FOR EARLIER VALUES AND SERIAL NUMBER RANGES OF PARTS MARKED WITH BLUE OUTLINE.

CRT CIRCUIT

WAVEFORM AND DYNAMIC VOLTAGE READINGS were obtained under the following conditions:

INTENSITY ccw

POWER ON

- * Voltage reading obtained with associated control set for normal operation. Voltage is dependent on position of the control.

Also see IMPORTANT note on "A or B or External Mode" Block diagram.

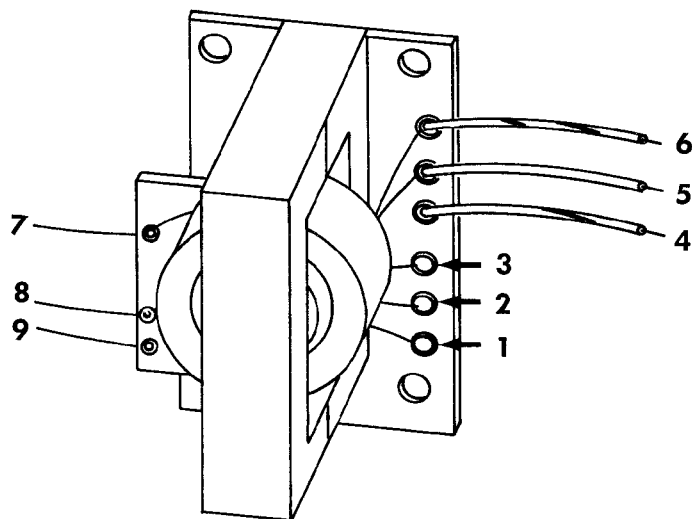

T801 TRANSFORMER DETAILS

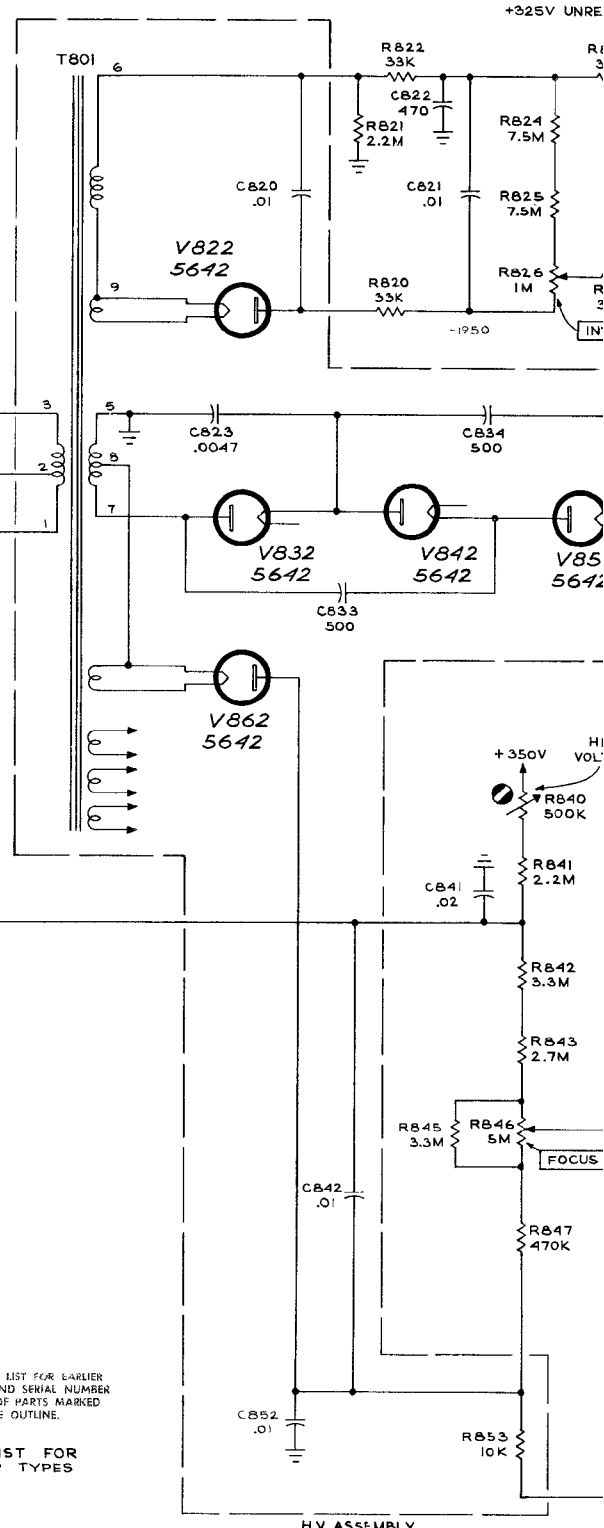
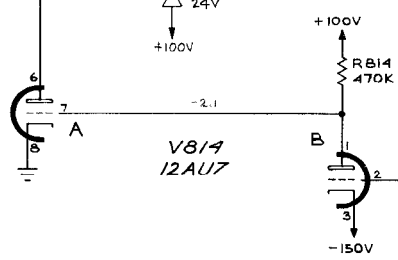
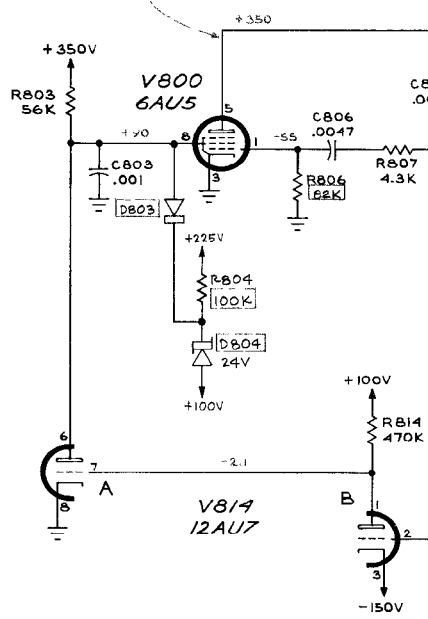
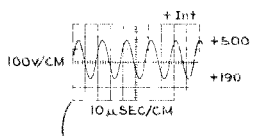
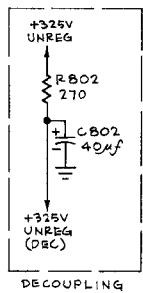

T801 TRANSFORMER DETAILS

REFERENCE DRAWINGS

- ① POWER SUPPLY & HEATER WIRING DIAG.
- ⑤ 'B' SWEEP GENERATOR
- ⑨ 'A' SWEEP GENERATOR
- ⑫ HORIZONTAL DISPLAY SWITCH
- ⑭ PLUG-IN CONNECTOR

SEE PARTS LIST FOR EARLIER VALUES AND SERIAL NUMBER RANGES OF PARTS MARKED WITH BLUE OUTLINE.
SEE PARTS LIST FOR SEMICONDUCTOR TYPES



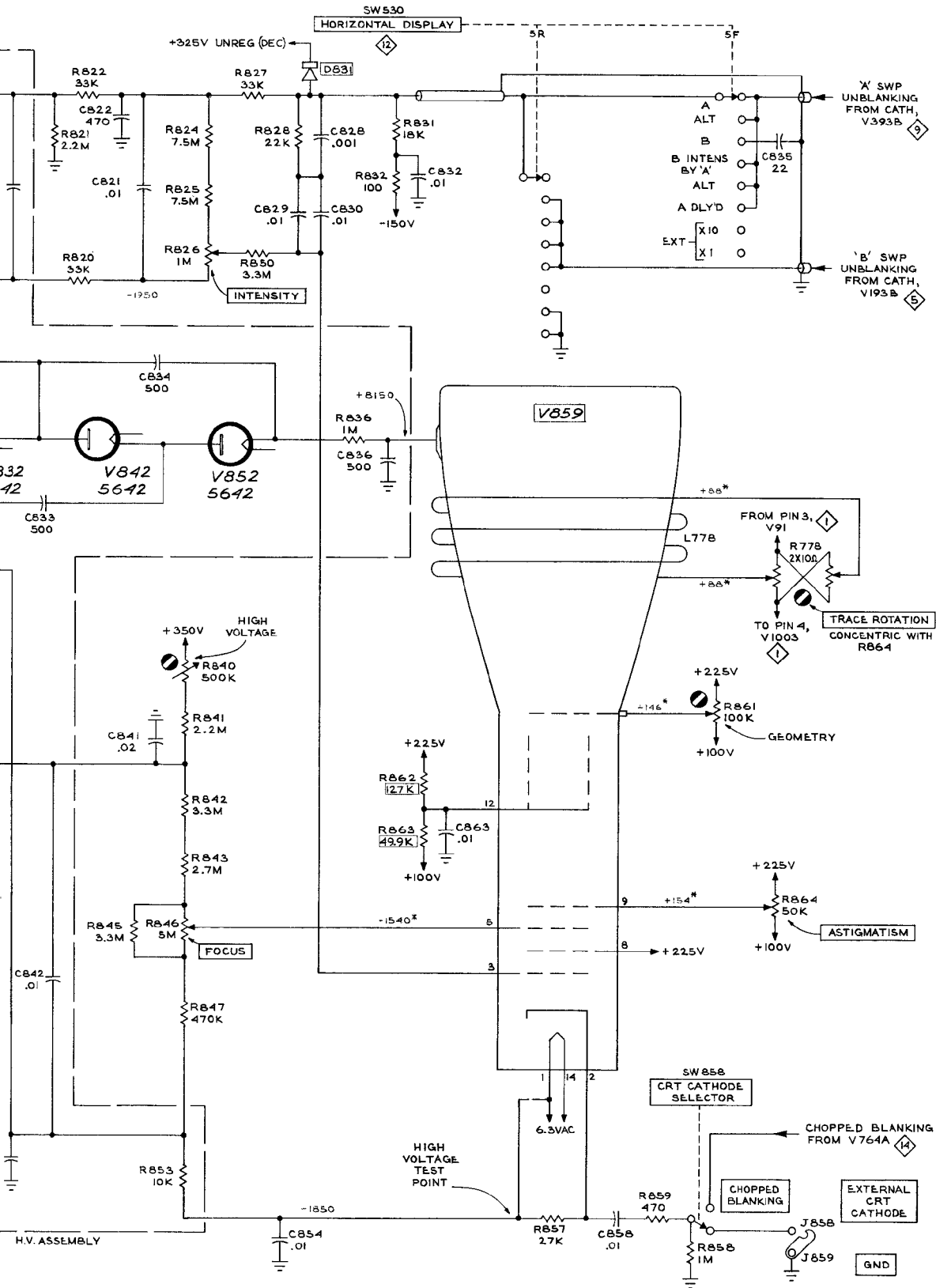

CMP
467
CRT CIRCUIT 2

VERTICAL AMPLIFIER

QUIESCENT VOLTAGE READINGS were obtained under the following conditions:

Oscilloscope:

POWER ON

Type 10-7:

INPUT SIGNAL None

VERTICAL POSITION Centered*

TEST FUNCTION COMMON MODE

*If a letter series or *F-series plug in unit is used, adjust the plug-in unit Vertical Position control to obtain zero volts reading between pins 1 and 3 of the interconnecting plug.

Also see IMPORTANT note on Block Diagram.

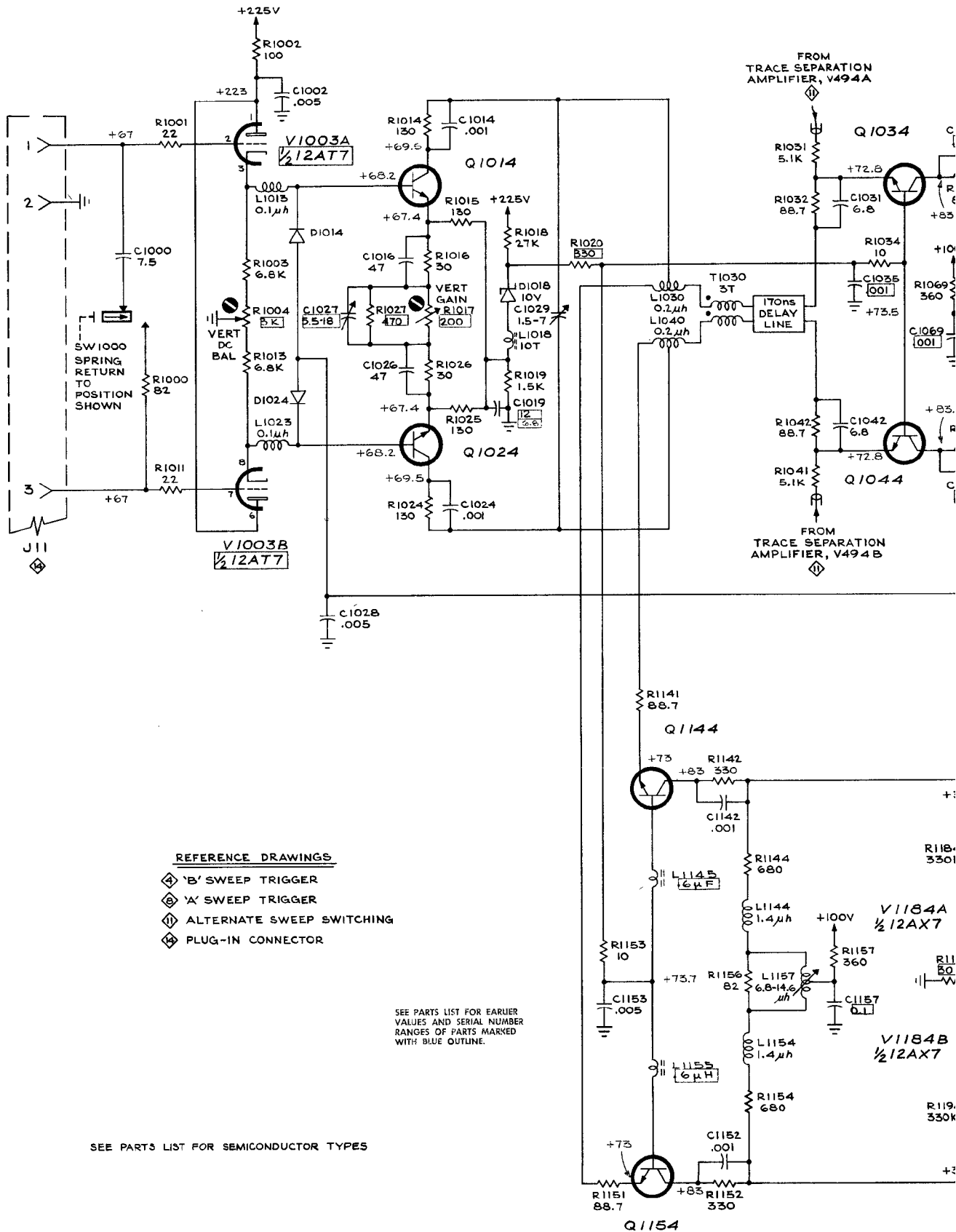

REFERENCE DRAWINGS

- ⊠ 'B' SWEEP TRIGGER
- ⊠ 'A' SWEEP TRIGGER
- ⊠ ALTERNATE SWEEP SWITCHING
- ⊠ PLUG-IN CONNECTOR

SEE PARTS LIST FOR EARLIER VALUES AND SERIAL NUMBER RANGES OF PARTS MARKED WITH BLUE OUTLINE.

SEE PARTS LIST FOR SEMICONDUCTOR TYPES

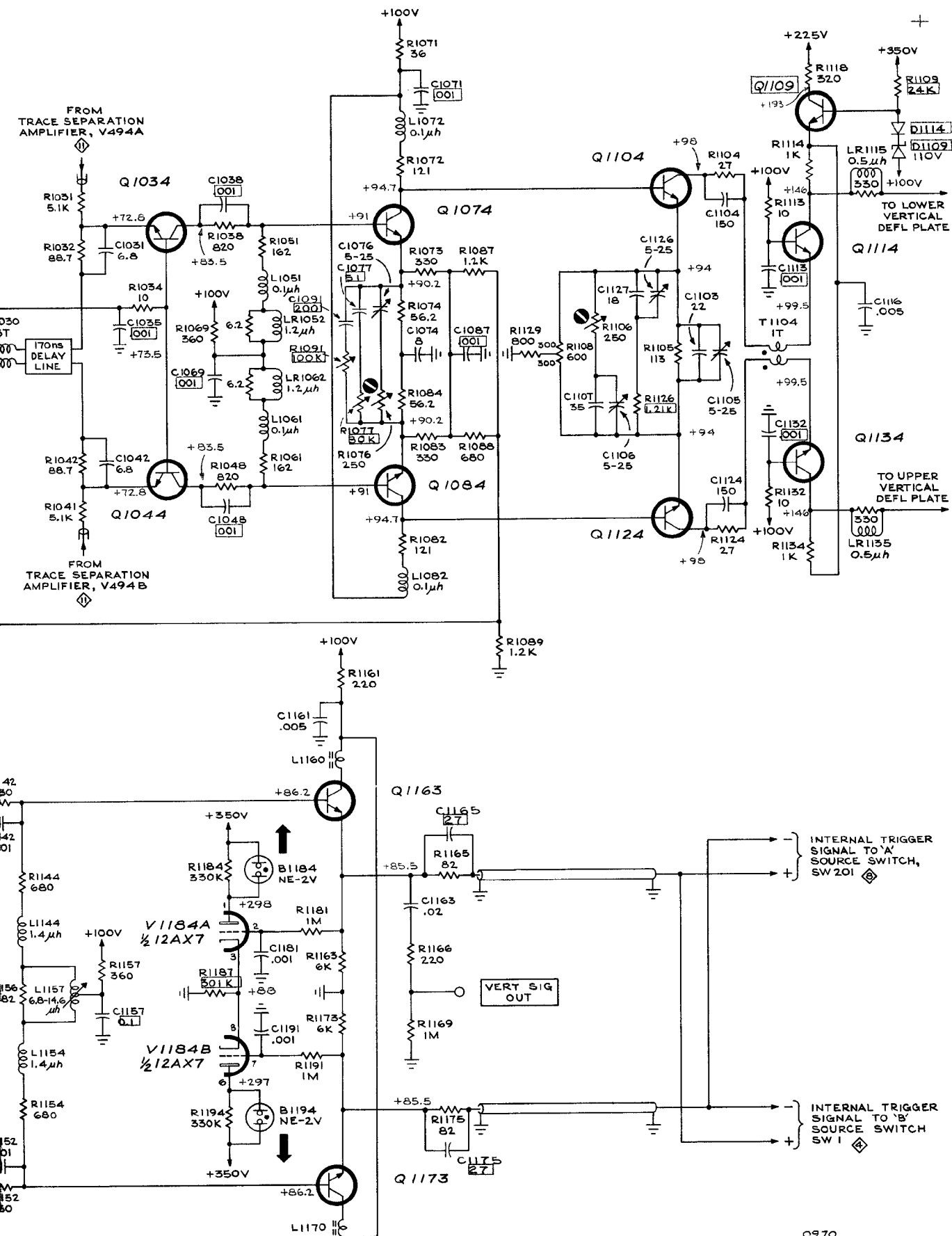

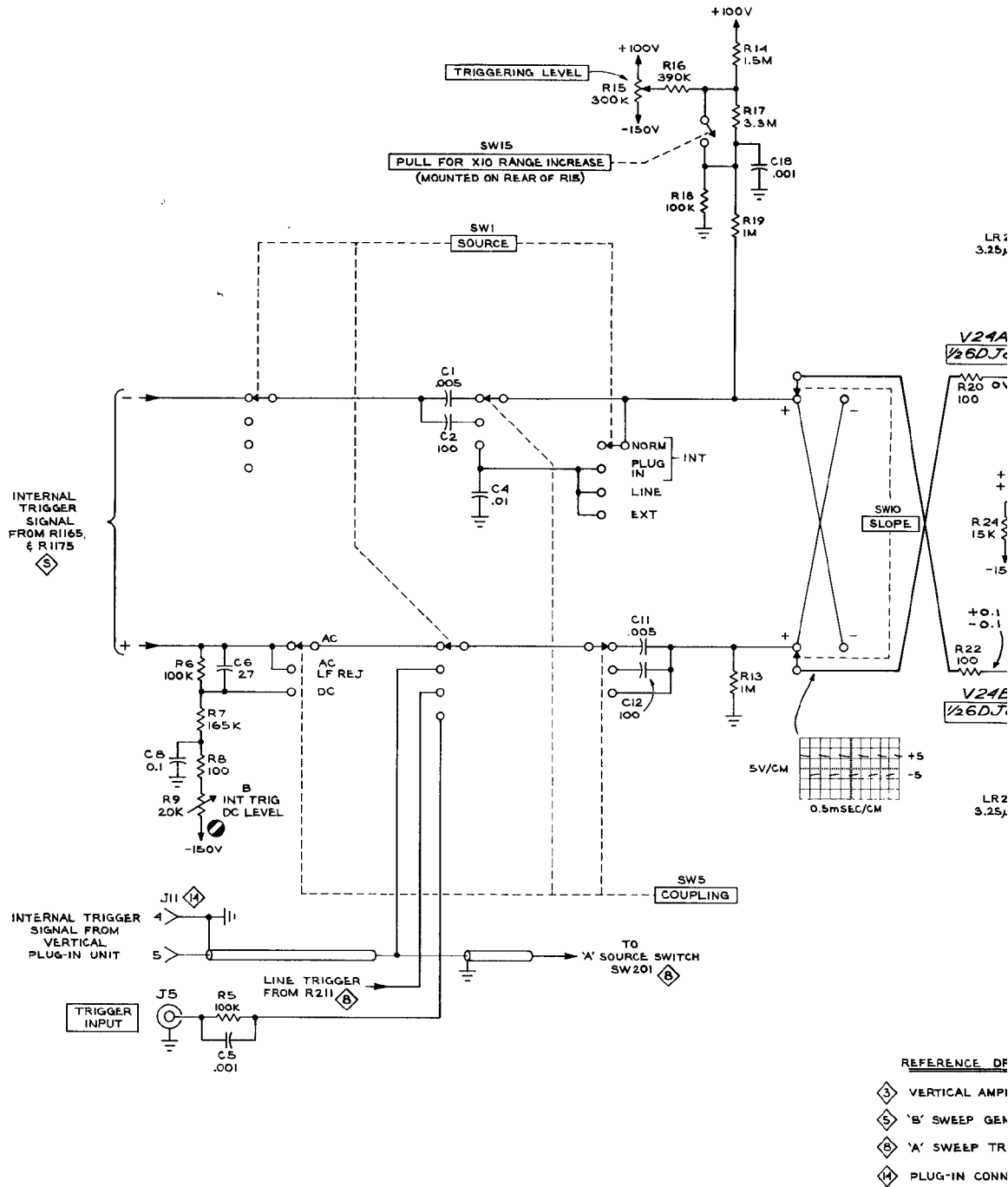

TYPE 547 OSCILLOSCOPE

+

R14
.5M
R17
5.3M
R19
M

C16
.001

R13
M
5V/CM
0.5mSEC/CM

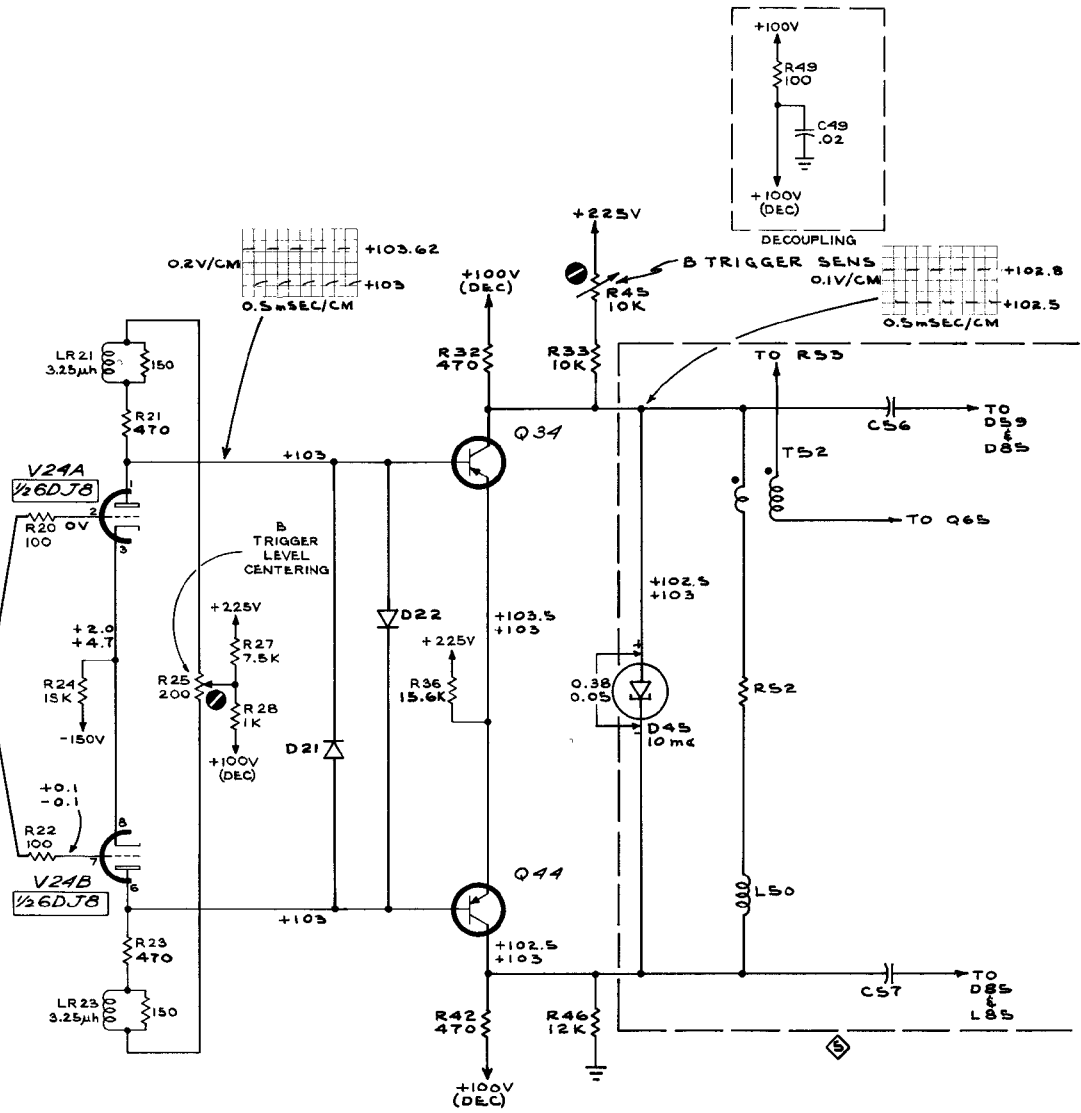
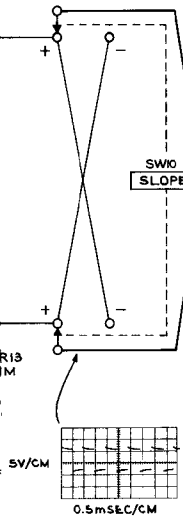

SEE PARTS LIST FOR EARLIER VALUES AND SERIAL NUMBER RANGES OF PARTS MARKED WITH BLUE OUTLINE.

REFERENCE DRAWINGS

- ③ VERTICAL AMPLIFIER
- ⑤ 'B' SWEEP GENERATOR
- ⑥ 'A' SWEEP TRIGGER
- ④ PLUG-IN CONNECTOR

SEE PARTS LIST FOR SEMICONDUCTOR TYPES

468
CMD

'B' SWEEP TRIGGER ④
(S/N 6T40-UP)

'B' SWEEP TRIGGER

WAVEFORMS AND VOLTAGE READINGS were obtained under the following conditions:

TIME BASE A —
TRIGGER INPUT Signal None
TRIGGERING:
MODE TRIG
SOURCE EXT

MAIN TIME BASE (B) —
TRIGGERING:
MODE TRIG
SLOPE +
COUPLING AC
SOURCE EXT

HORIZONTAL DISPLAY B

POWER ON

WAVEFORM Conditions —
'B' TRIGGER INPUT Signal 10 Volts P-P Calibrator
'B' TRIGGERING LEVEL +45°; knob pushed in
'B' TIME/CM1 mSEC
AMPLITUDE CALIBRATOR 10 Volts

QUIESCENT VOLTAGE Conditions —
'B' TRIGGER INPUT Signal None
'B' TRIGGERING LEVEL with knob pushed in:
Upper Voltage Readings ccw
Lower Voltage Readings cw

Also see IMPORTANT note on "A or B or External Mode" Block diagram.

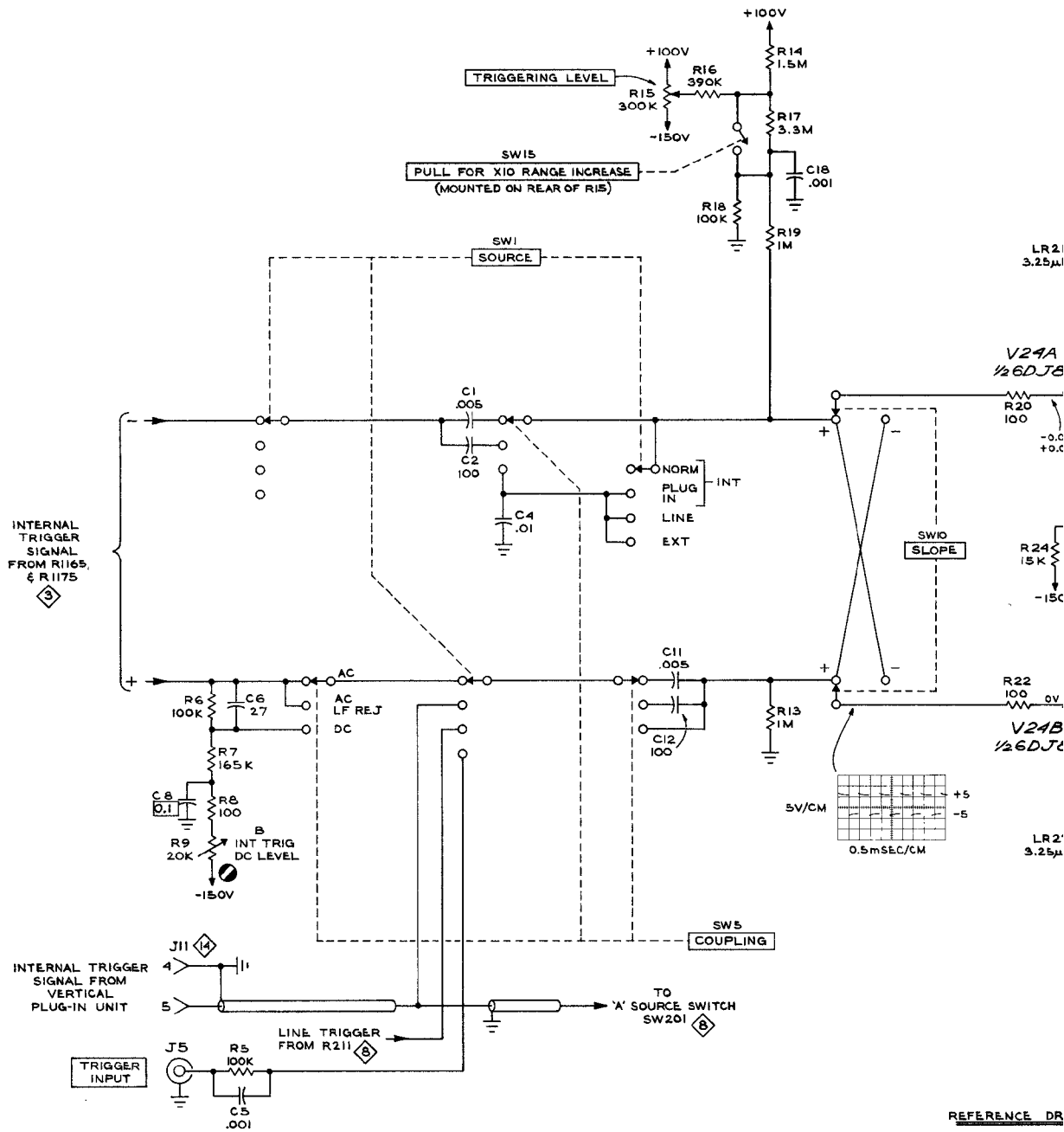

SEE PARTS LIST FOR EARLIER VALUES AND SERIAL NUMBER RANGES OF PARTS MARKED WITH BLUE OUTLINE

TYPE 547 OSCILLOSCOPE

+

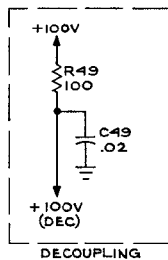

4
M
7
AM
C18
.001
9

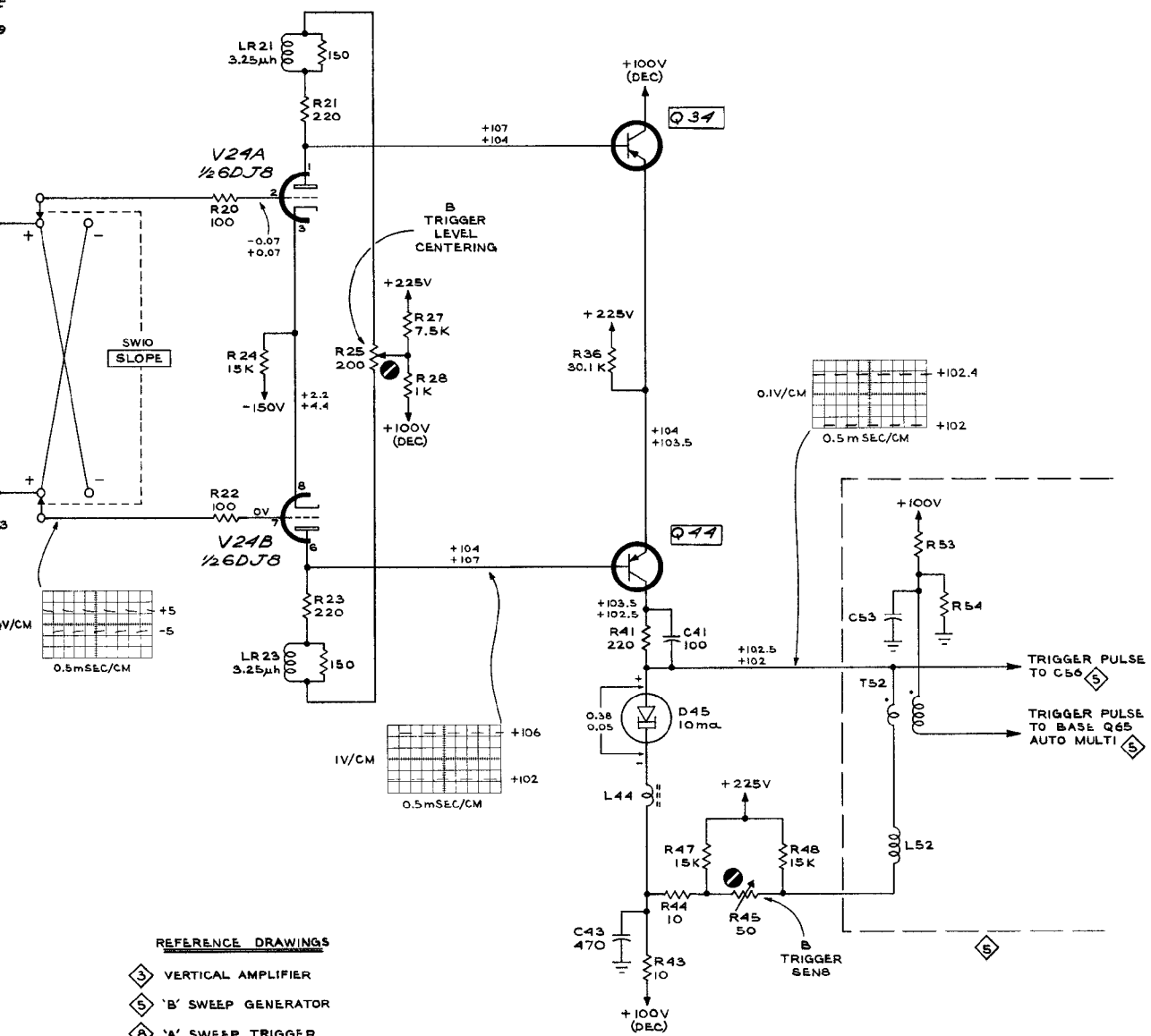

REFERENCE DRAWINGS

- ③ VERTICAL AMPLIFIER
- ⑤ 'B' SWEEP GENERATOR
- ⑥ 'A' SWEEP TRIGGER
- ⑭ PLUG-IN CONNECTOR

SEE PARTS LIST FOR SEMICONDUCTOR TYPES

567
CMD

'B' SWEEP TRIGGER ④
(S/N 100-6739)

C1

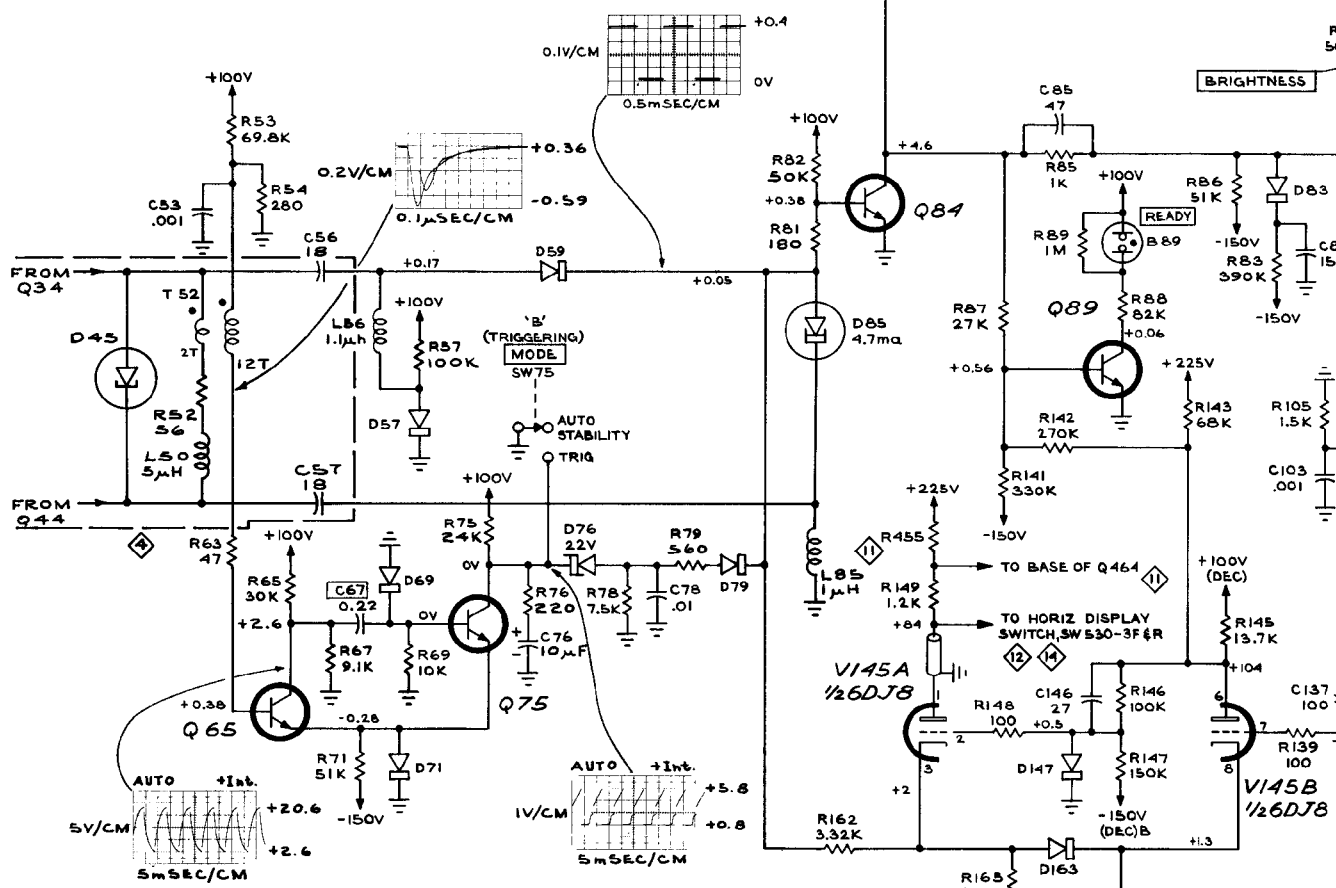
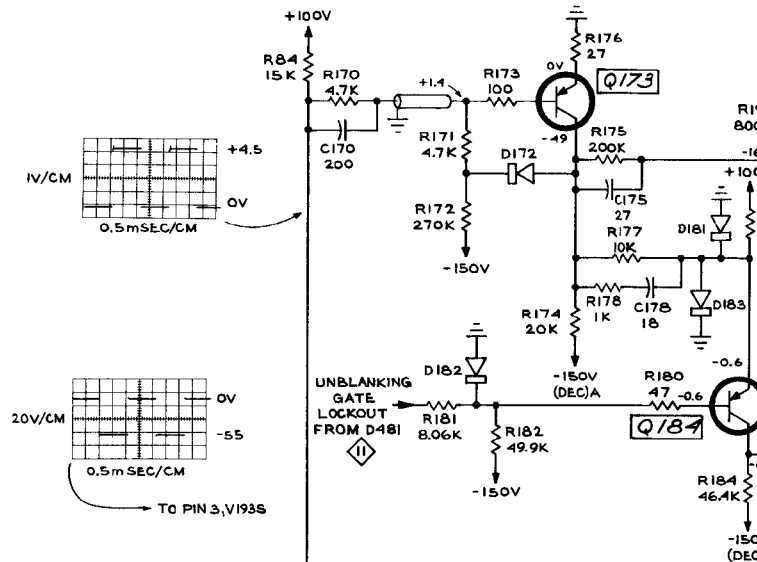
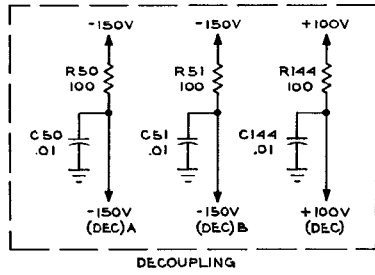

SEE PARTS LIST FOR EARLIER VALUES AND SERIAL NUMBER RANGES OF PARTS MARKED WITH BLUE OUTLINE.

- ALT
- B INTENS BY 'A'
- ALT
- A DLY'D
- X10 EXT
- X1

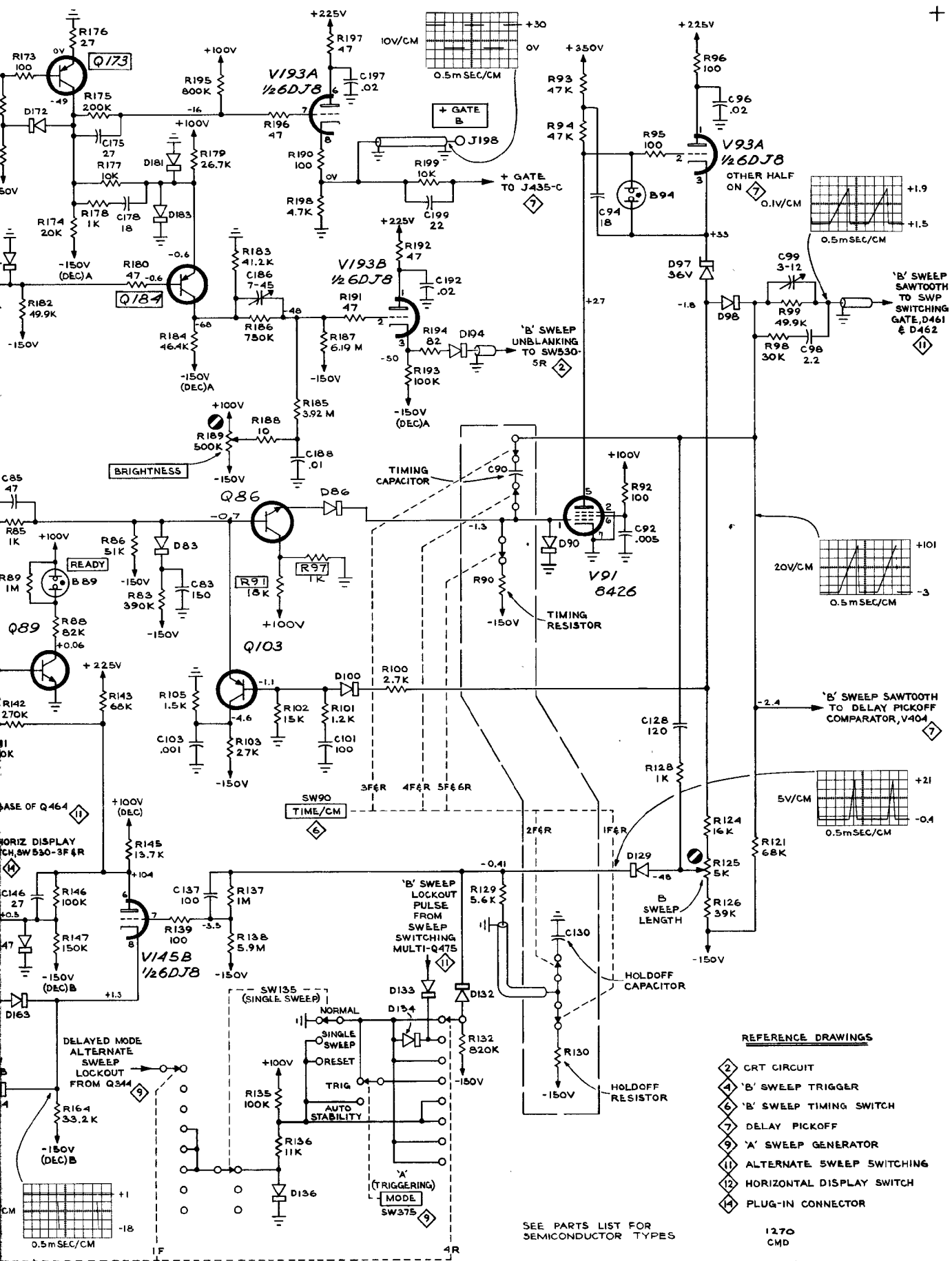

REV. D, SEPT. 1975

SEE PARTS LIST FOR SEMICONDUCTOR TYPES

REFERENCE DRAWINGS

- ② CRT CIRCUIT
- ④ 'B' SWEEP TRIGGER
- ⑥ 'B' SWEEP TIMING SWITCH
- ⑦ DELAY PICKOFF
- ⑨ 'A' SWEEP GENERATOR
- ⑪ ALTERNATE SWEEP SWITCHING
- ⑫ HORIZONTAL DISPLAY SWITCH
- ⑭ PLUG-IN CONNECTOR

'B' SWEEP GENERATOR ⑤

1270 CND

'B' SWEEP GENERATOR

WAVEFORMS AND VOLTAGE READINGS were obtained under the following conditions:

TIME BASE A —

TRIGGER INPUT Signal None
TRIGGERING:
MODE TRIG
SOURCE EXT

HORIZONTAL DISPLAY B
SINGLE SWEEP Switch NORMAL

MAIN TIME BASE (B)

TRIGGERING LEVEL +45°; pushed in
TRIGGERING:
SLOPE +
COUPLING AC
SOURCE EXT
BRIGHTNESS cw
TIME/CM1 mSEC
VARIABLE (TIME/CM) CALIBRATED

POWER ON

WAVEFORM CONDITIONS —

'B' TRIGGER INPUT SIGNAL 10 Volts P-P Calibrator
'B' TRIGGERING MODE TRIG (AUTO for waveforms at
collectors of Q65 and Q75).
AMPLITUDE CALIBRATOR 10 Volts

QUIESCENT VOLTAGE CONDITIONS —

'B' TRIGGER INPUT SIGNAL None
'B' TRIGGERING MODE TRIG

Also see IMPORTANT note on "A or B or External Mode" Block diagram.

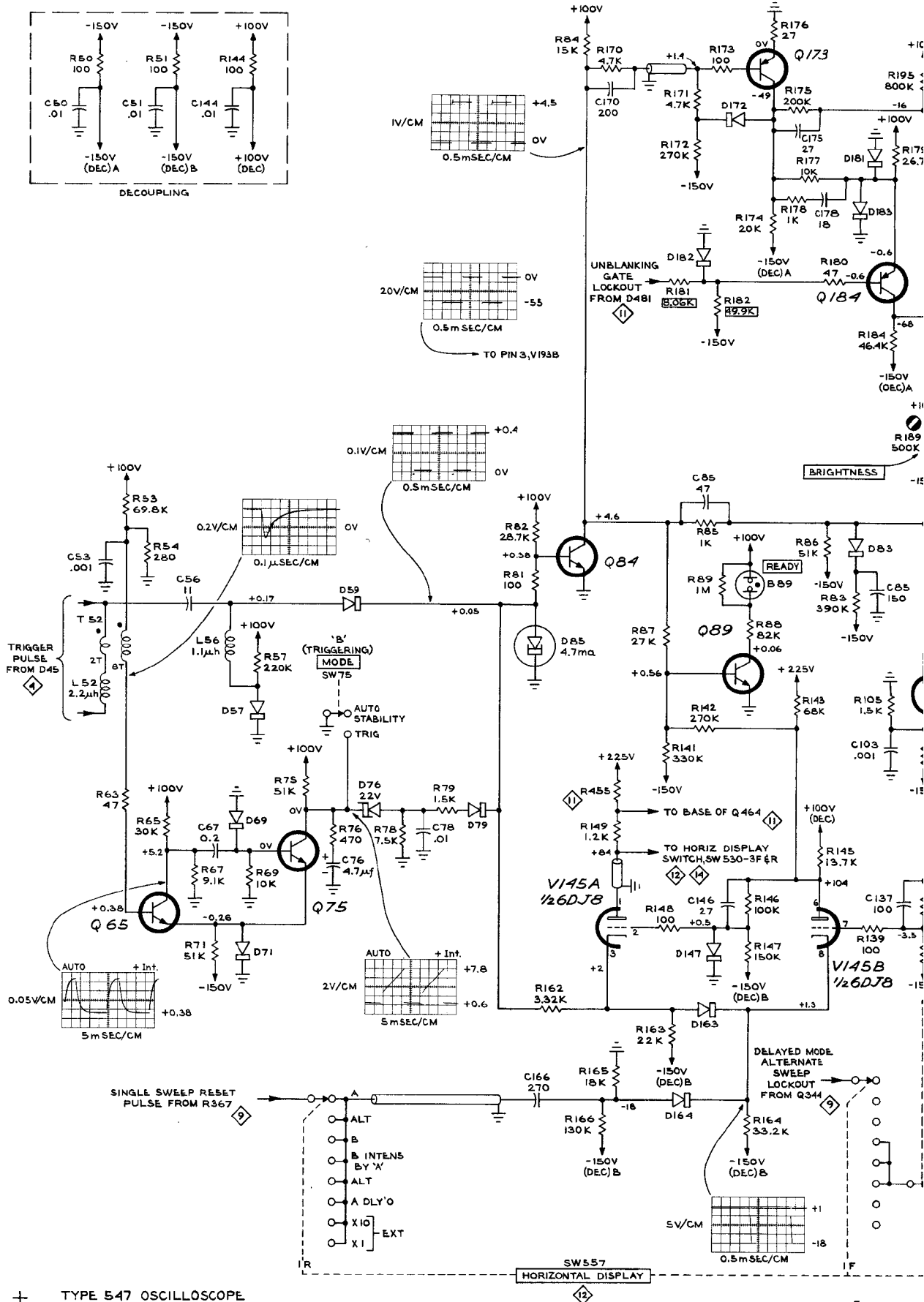
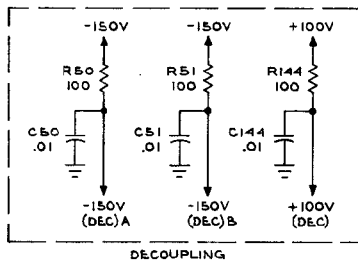

+ TYPE 547 OSCILLOSCOPE

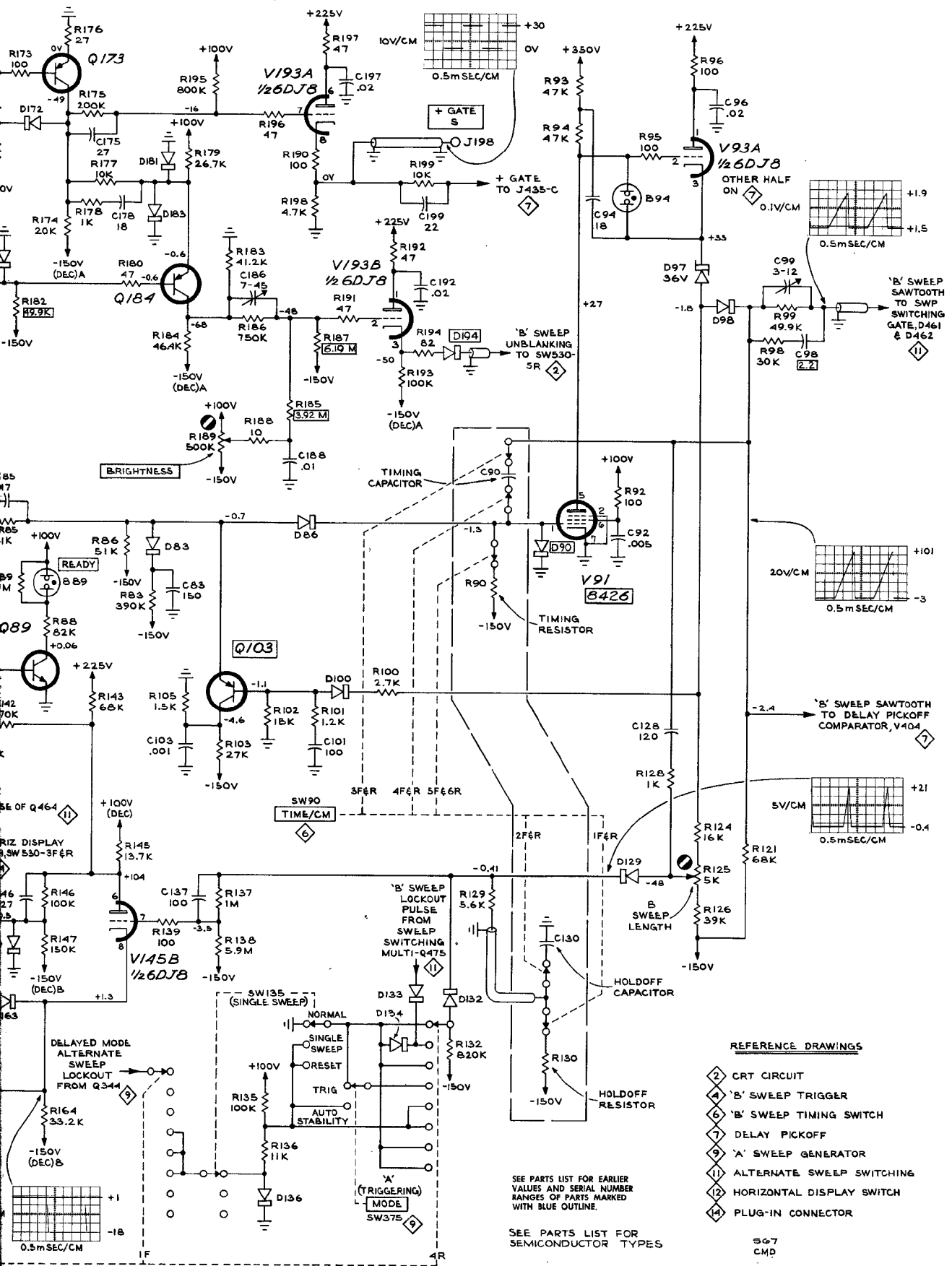

REFERENCE DRAWINGS

- 2 CRT CIRCUIT
- 4 'B' SWEEP TRIGGER
- 6 'B' SWEEP TIMING SWITCH
- 7 DELAY PICKOFF
- 9 'A' SWEEP GENERATOR
- 11 ALTERNATE SWEEP SWITCHING
- 12 HORIZONTAL DISPLAY SWITCH
- 14 PLUG-IN CONNECTOR

SEE PARTS LIST FOR EARLIER VALUES AND SERIAL NUMBER RANGES OF PARTS MARKED WITH BLUE OUTLINE.

SEE PARTS LIST FOR SEMICONDUCTOR TYPES

567
CMP

'B' SWEEP GENERATOR (S/N 100-6739)

F1

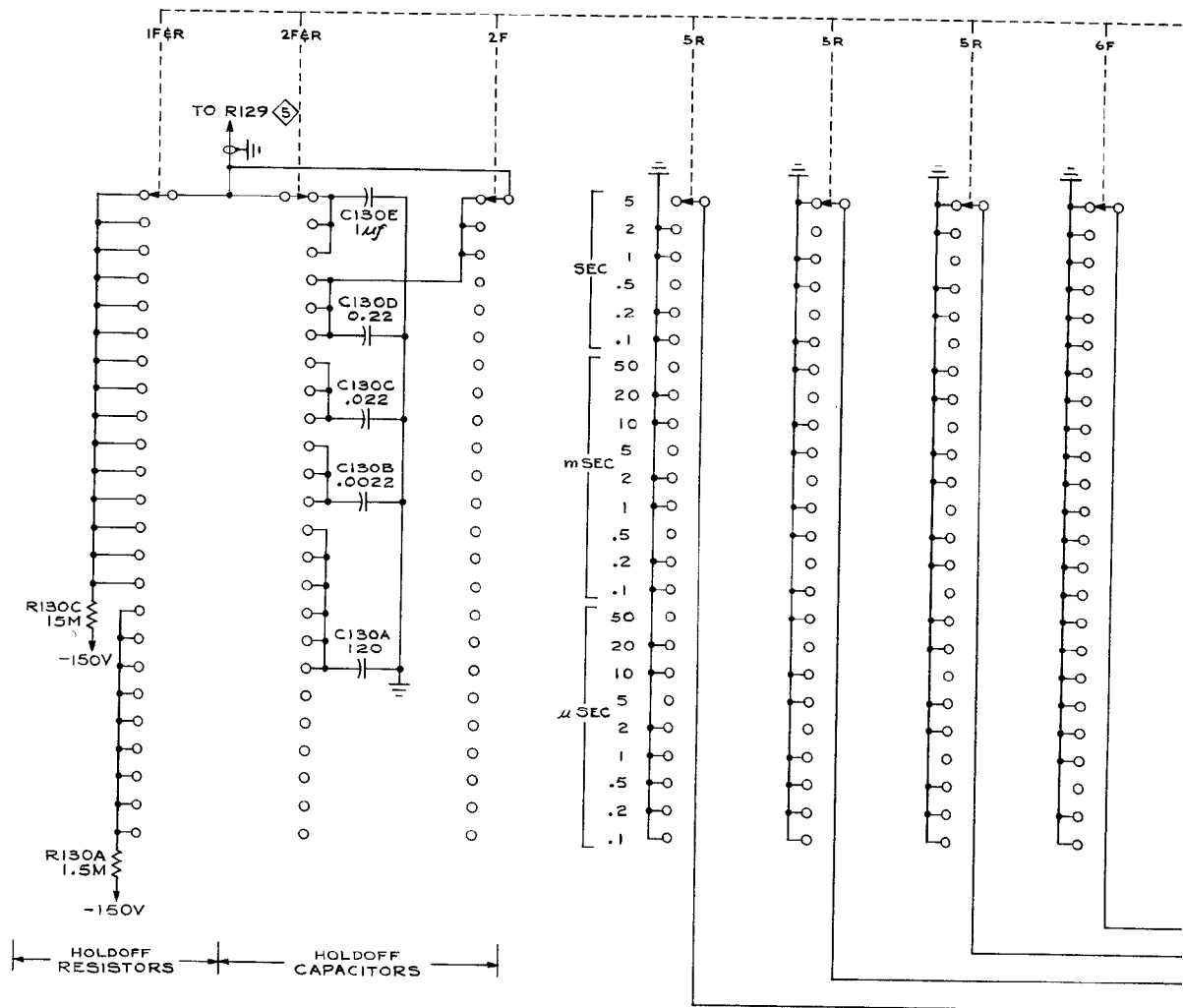

REFERENCE DRAWINGS:

(S) 'B' SWEEP GENERATOR

SEE PARTS LIST FOR VALUES AND SERIAL RANGES OF PARTS WITH BLUE OUTLINE.

TYPE 547 OSCILLOSCOPE

REV.D, JAN. 1954

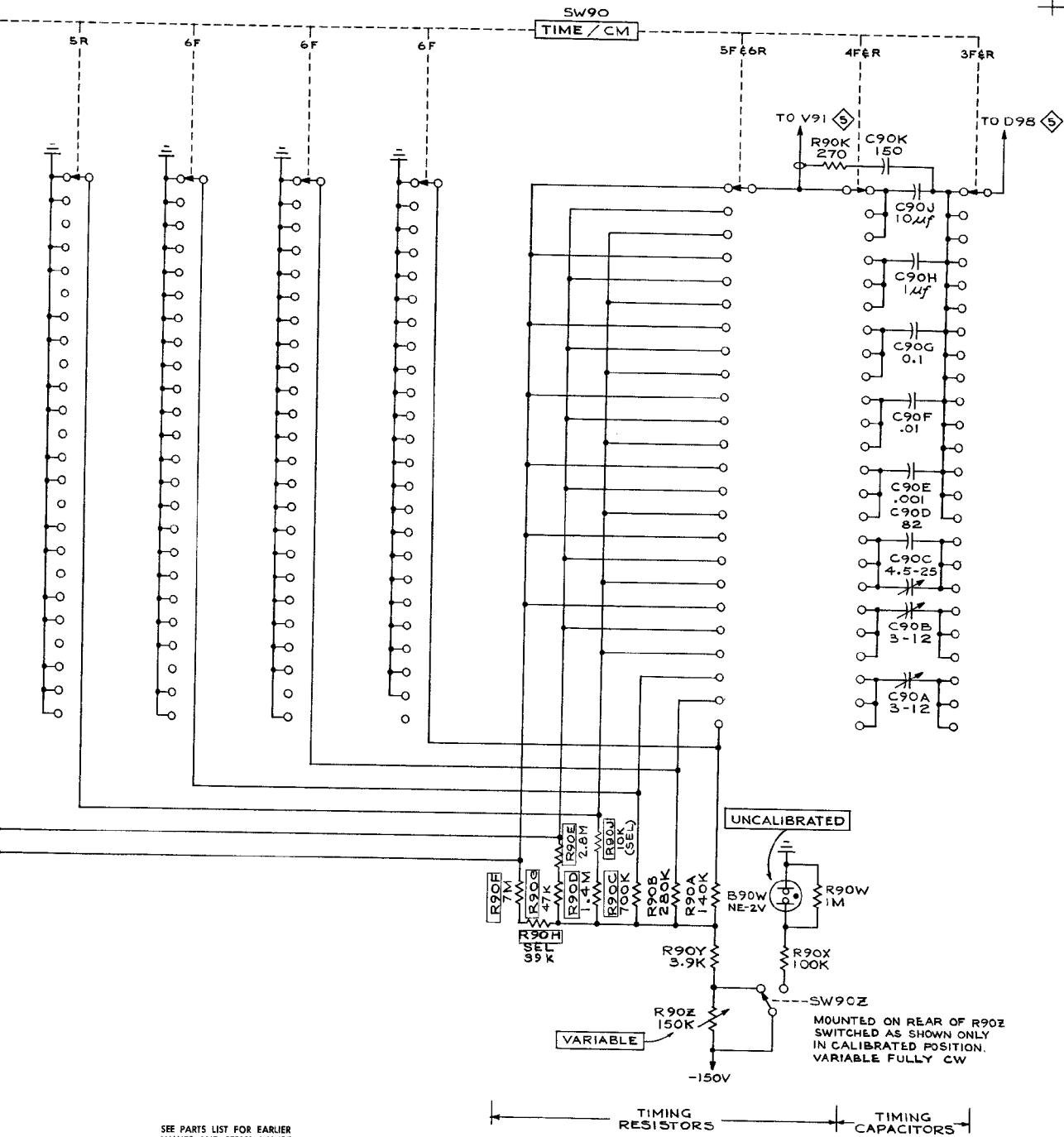

SEE PARTS LIST FOR EARLIER
VALUES AND SERIAL NUMBER
RANGES OF PARTS MARKED
WITH BLUE OUTLINE.

MOUNTED ON REAR OF R90Z
SWITCHED AS SHOWN ONLY
IN CALIBRATED POSITION.
VARIABLE FULLY CW

REV.D, JAN. 1975

MRH
668
'B' SWEEP TIMING SWITCH 6

DELAY PICKOFF

WAVEFORMS AND VOLTAGE READINGS were obtained under the following conditions:

TIME BASE A —

'A' TRIGGER INPUT Signal None
'A' TRIGGERING LEVEL ccw
TIME/CM1 mSEC/CM
VARIABLE CALIBRATED

SINGLE SWEEP Switch NORMAL

MAIN TIME BASE (B) —

TRIGGERING LEVEL +45°; push in
TRIGGERING:
MODE TRIG
SLOPE +
COUPLING AC
SOURCE EXT
TIME/CM1 mSEC/CM
VARIABLE CALIBRATED

DELAY-TIME MULTIPLIER 2.00

POWER ON

WAVEFORM CONDITIONS —

'A' TRIGGERING MODE AUTO
HORIZONTAL DISPLAY A DLY'D
'B' TRIGGER INPUT Signal 10 Volts P-P Calibrator
AMPLITUDE CALIBRATOR 10 Volts

QUIESCENT VOLTAGE CONDITIONS —

'A' TRIGGERING MODE TRIG
HORIZONTAL DISPLAY B
'B' TRIGGER INPUT Signal None

Also see IMPORTANT note on "A or B or External Mode" Block diagram.

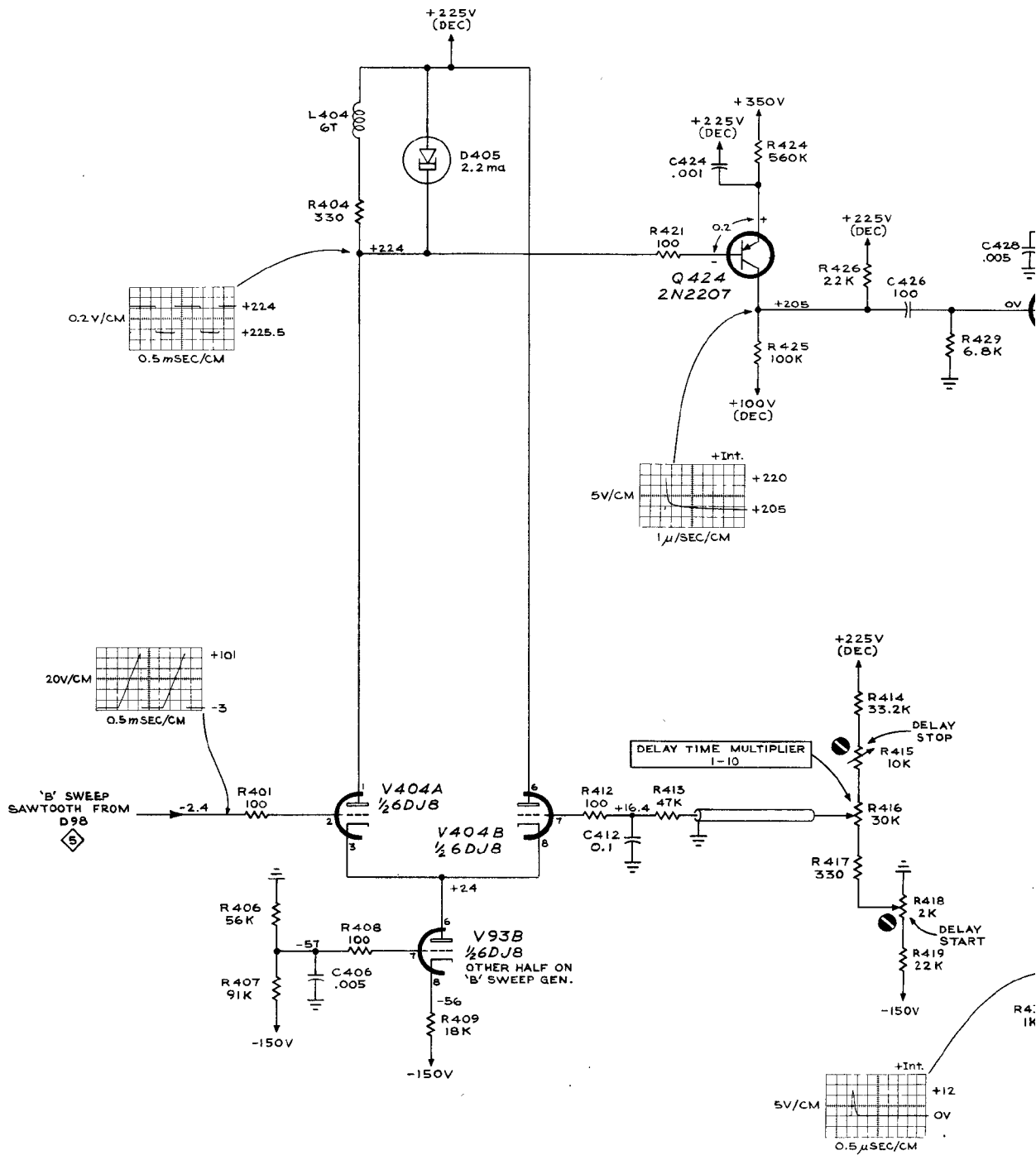

REFERENCE DRAWINGS

- ⑤ 'B' SWEEP GENERATOR
- ⑨ 'A' SWEEP GENERATOR
- ⑬ HORIZONTAL DISPLAY SWITCH

TYPE 547 OSCILLOSCOPE

B

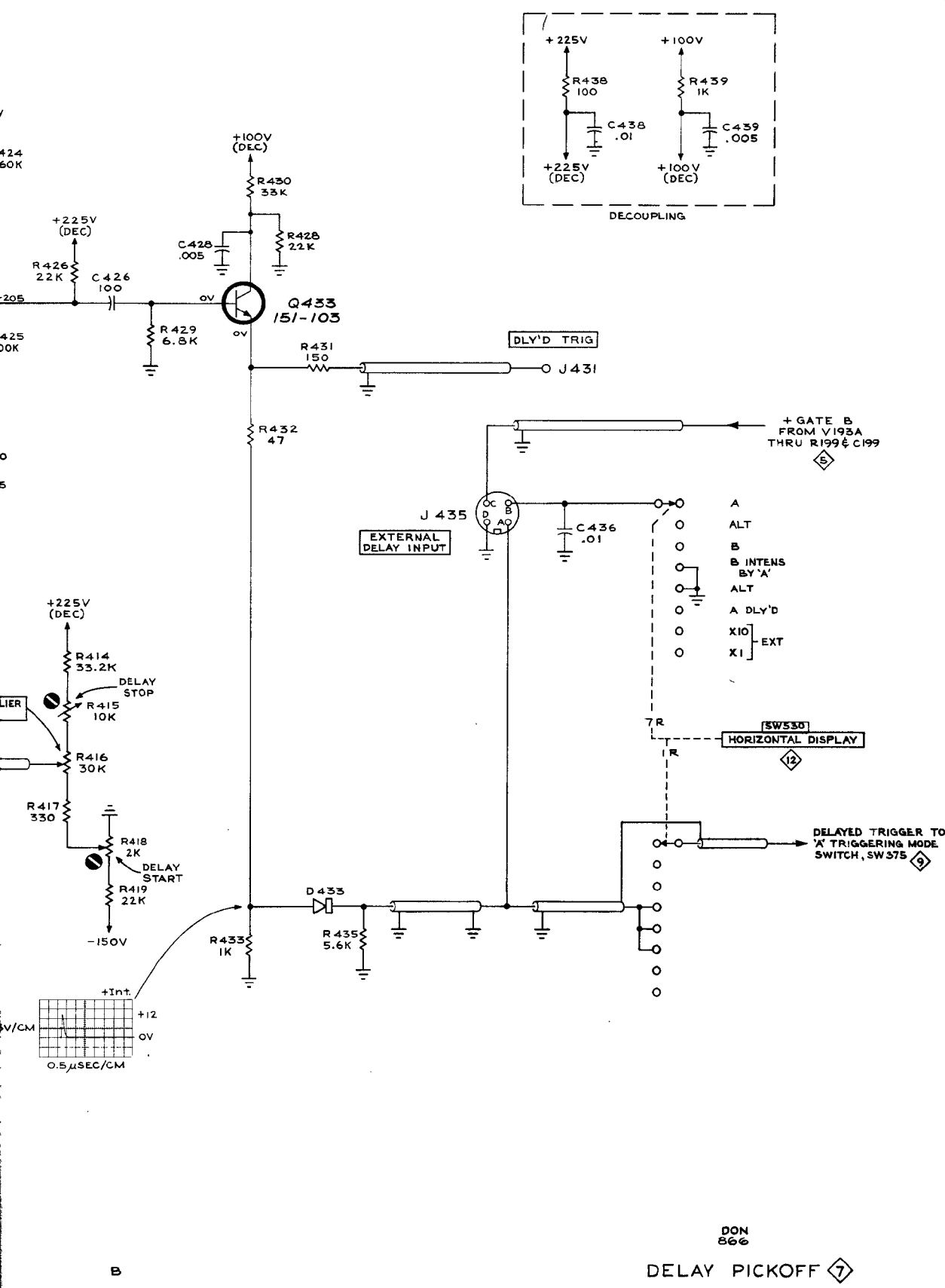

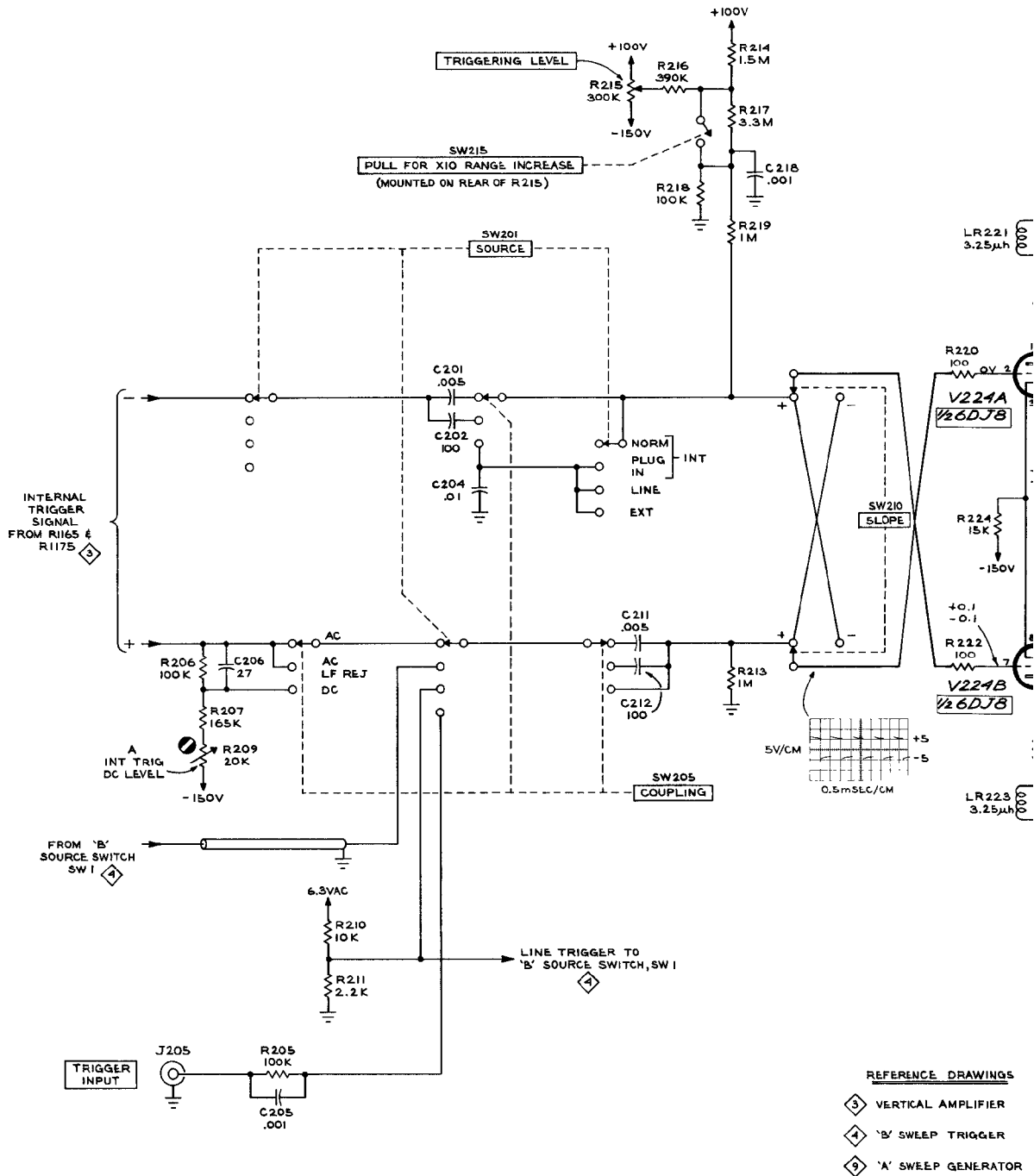

TYPE 547 OSCILLOSCOPE

C218
001

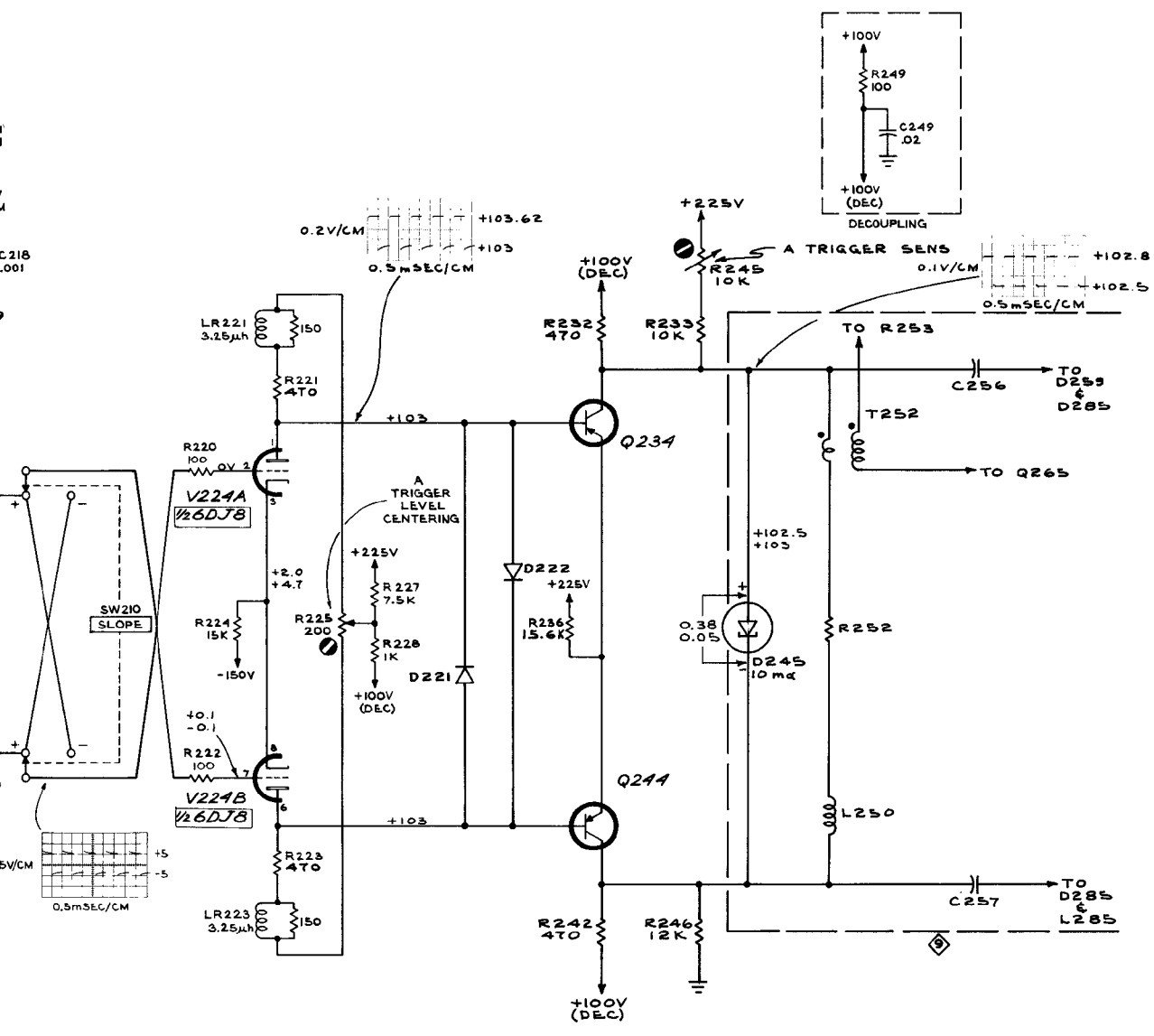

REFERENCE DRAWINGS

- ③ VERTICAL AMPLIFIER
- ④ 'B' SWEEP TRIGGER
- ⑤ 'A' SWEEP GENERATOR

SEE PARTS LIST FOR EARLIER
VALUES AND SERIAL NUMBER
RANGES OF PARTS MARKED
WITH BLUE OUTLINE.

967
CMD

'A' SWEEP TRIGGER ⑤
(S/N 6740-UP)

'A' SWEEP TRIGGER

WAVEFORMS AND VOLTAGE READINGS were obtained under the following conditions:

TIME BASE A —

TRIGGERING:

MODE	TRIG
SLOPE	+
COUPLING	AC
SOURCE	EXT

MAIN TIME BASE (B) —

TRIGGER INPUT Signal	None
MODE	TRIG
SOURCE	EXT

HORIZONTAL DISPLAY A

POWER ON

WAVEFORM CONDITIONS —

'A' TRIGGER INPUT Signal	10 Volts P-P Calibrator
'A' TRIGGERING LEVEL	+45°; knob pushed in
'A' TIME/CM1 mSEC
AMPLITUDE CALIBRATOR	10 Volts

QUIESCENT VOLTAGE CONDITIONS —

'A' TRIGGER INPUT Signal	None
'A' TRIGGERING LEVEL with knob pushed in:	
Upper Voltage Readings	ccw
Lower Voltage Readings	cw

Also see IMPORTANT note on "A or B or External Mode" Block diagram.

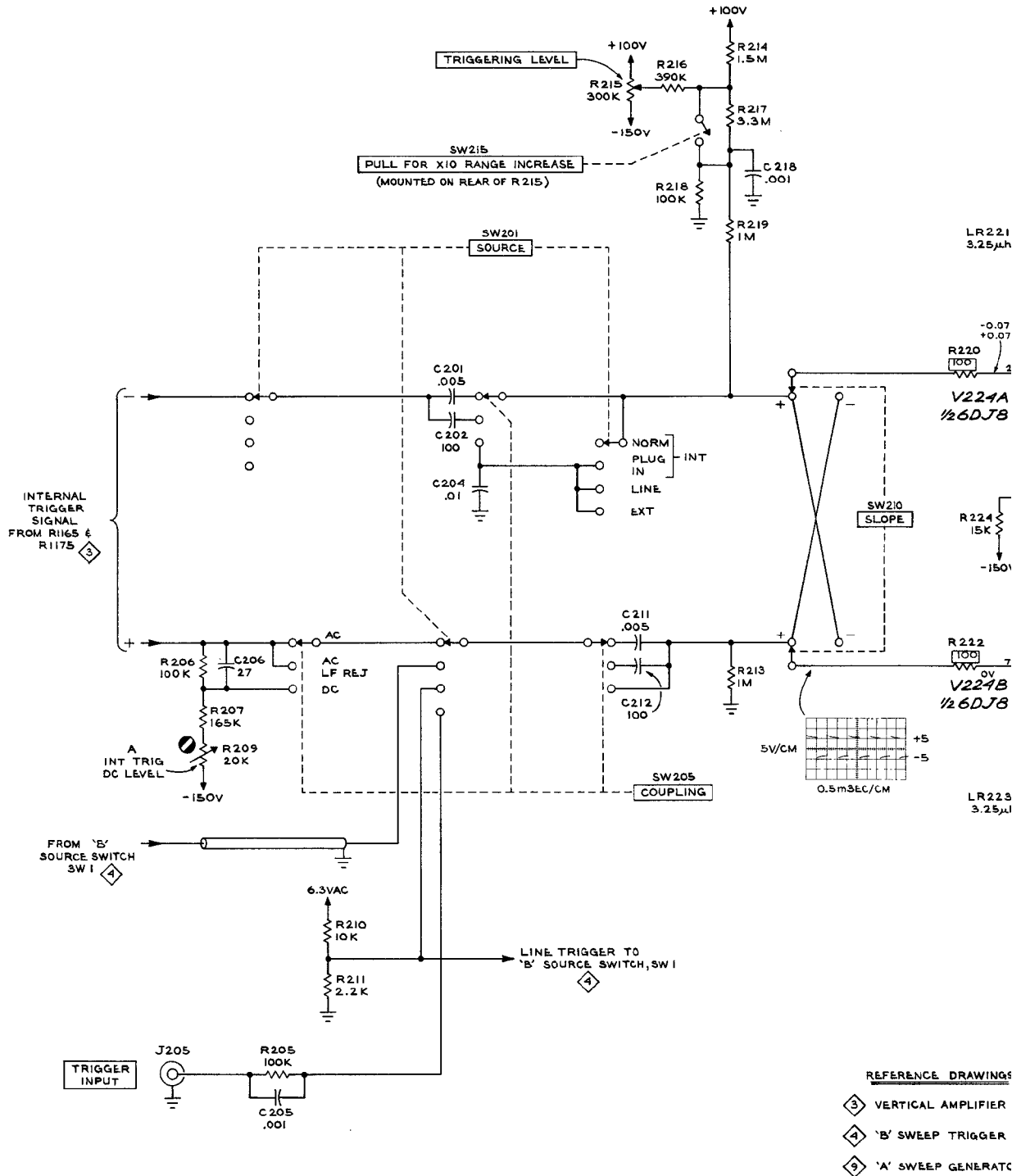

TYPE 547 OSCILLOSCOPE

C218
.001

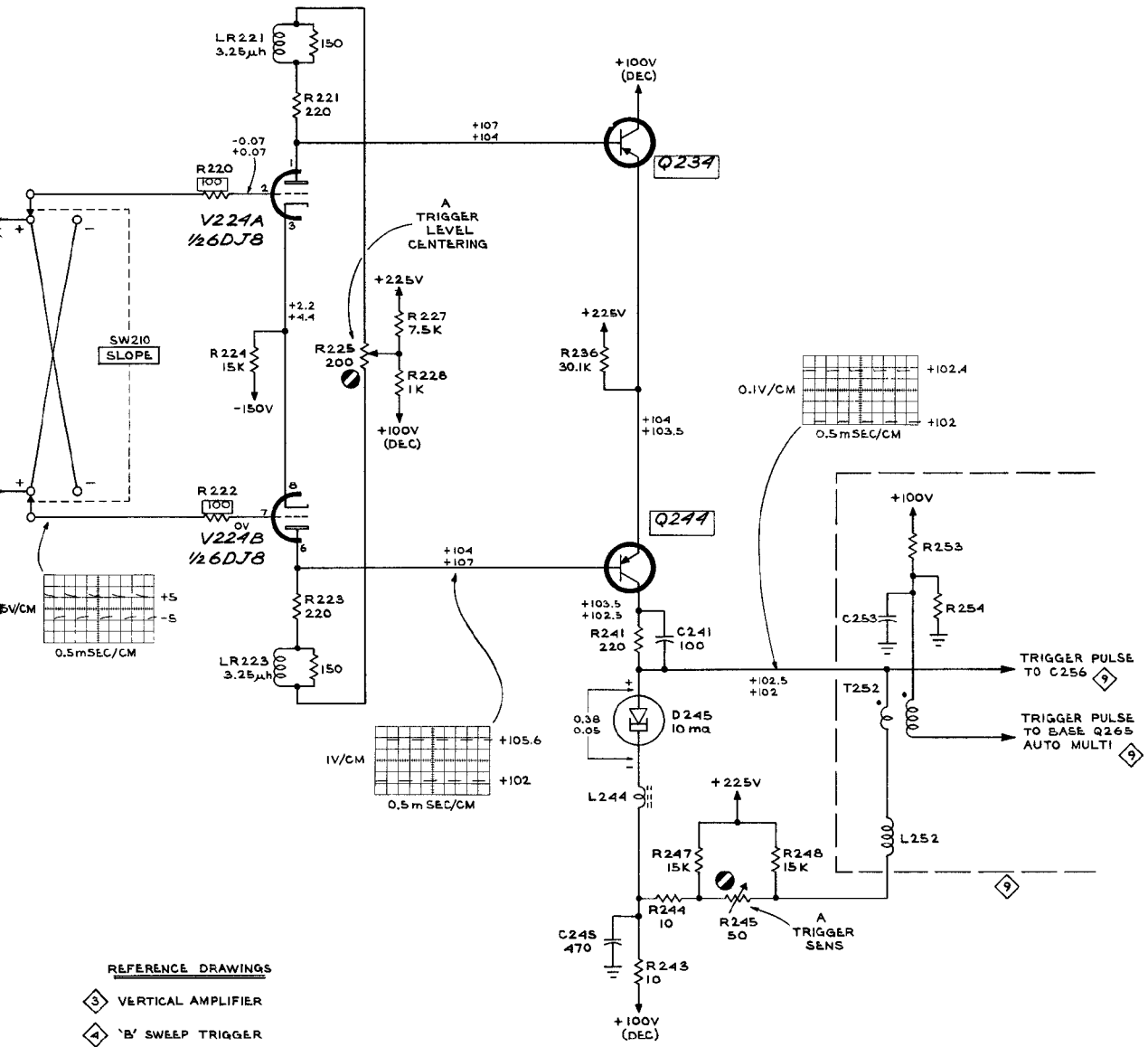
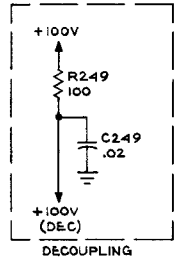

REFERENCE DRAWINGS

- 3 VERTICAL AMPLIFIER
- 4 'B' SWEEP TRIGGER
- 9 'A' SWEEP GENERATOR

SEE PARTS LIST FOR EARLIER VALUES AND SERIAL NUMBER RANGES OF PARTS MARKED WITH BLUE OUTLINE.

567
CMD

'A' SWEEP TRIGGER (S/N 100-6739)

C1

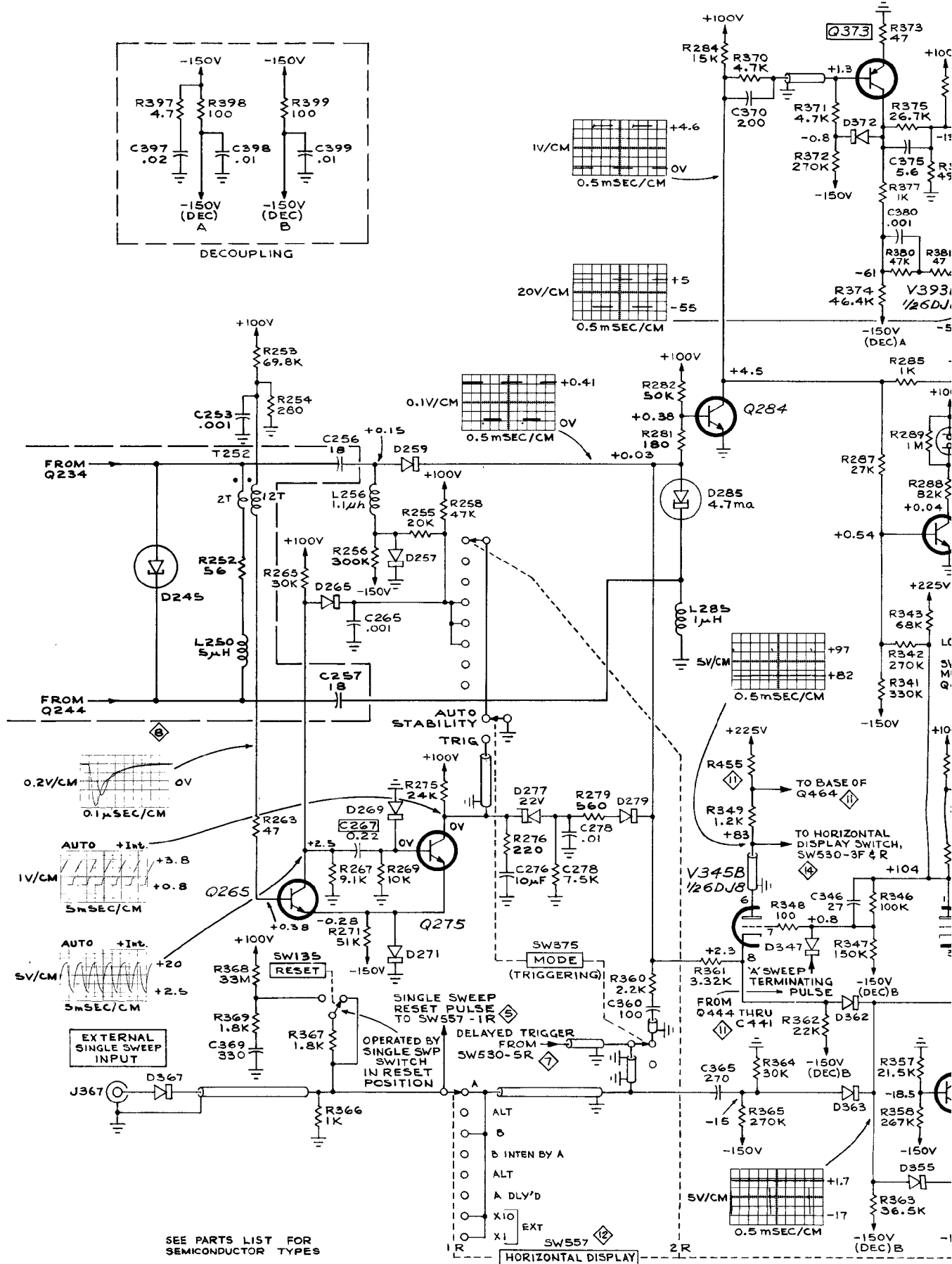
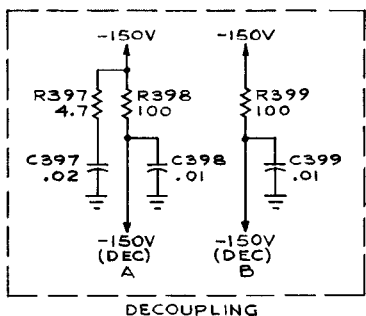

SEE PARTS LIST FOR SEMICONDUCTOR TYPES

TYPE 547 OSCILLOSCOPE

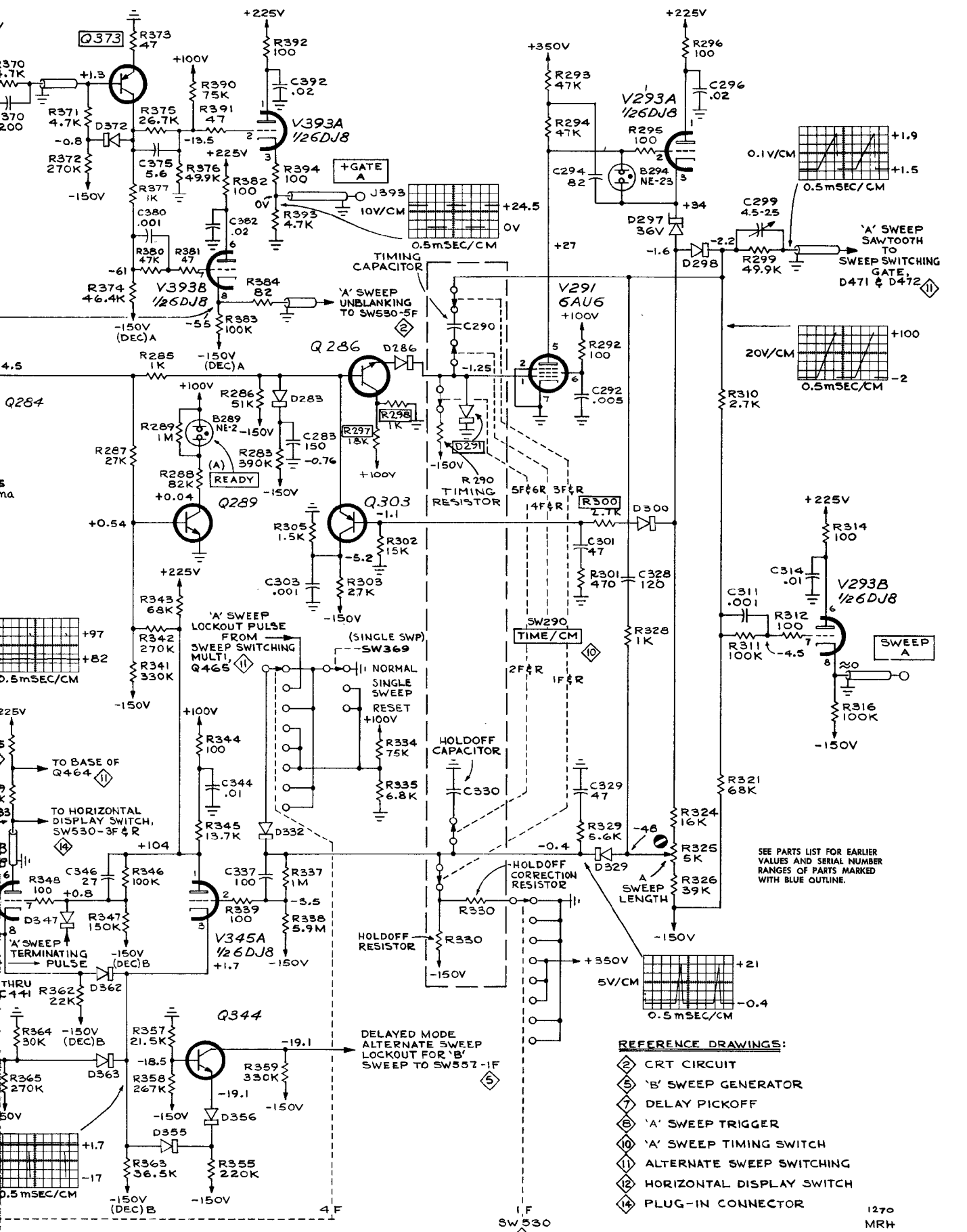

REV. D, SEPT. 1975

REFERENCE DRAWINGS:

- ② CRT CIRCUIT
- ⑤ 'B' SWEEP GENERATOR
- ⑦ DELAY PICKOFF
- ⑧ 'A' SWEEP TRIGGER
- ⑩ 'A' SWEEP TIMING SWITCH
- ⑪ ALTERNATE SWEEP SWITCHING
- ⑫ HORIZONTAL DISPLAY SWITCH
- ⑭ PLUG-IN CONNECTOR

1270
MRH

'A' SWEEP GENERATOR ⑨
(S/N 6740-UP)

'A' SWEEP GENERATOR

WAVEFORMS AND VOLTAGE READINGS were obtained under the following conditions:

TIME BASE A —
TRIGGERING LEVEL +45°; knob pushed in
TRIGGERING:
SLOPE +
COUPLING AC
SOURCE EXT
TIME/CM1 mSEC
VARIABLE CALIBRATED

HORIZONTAL DISPLAY A

SINGLE SWEEP Switch NORMAL

MAIN TIME BASE (B) —
TRIGGER INPUT Signal None
TRIGGERING:
MODE TRIG
SOURCE EXT

POWER ON

WAVEFORM CONDITIONS —
'A' TRIGGER INPUT Signal 10 Volts P-P Calibrator
'A' TRIGGERING MODE TRIG (AUTO for waveforms at
collectors of Q265 and Q275).
AMPLITUDE CALIBRATOR 10 Volts

QUIESCENT VOLTAGE CONDITIONS
'A' TRIGGER INPUT Signal None
'A' TRIGGERING MODE TRIG

Also see IMPORTANT note on "A or B or External Mode" Block diagram.

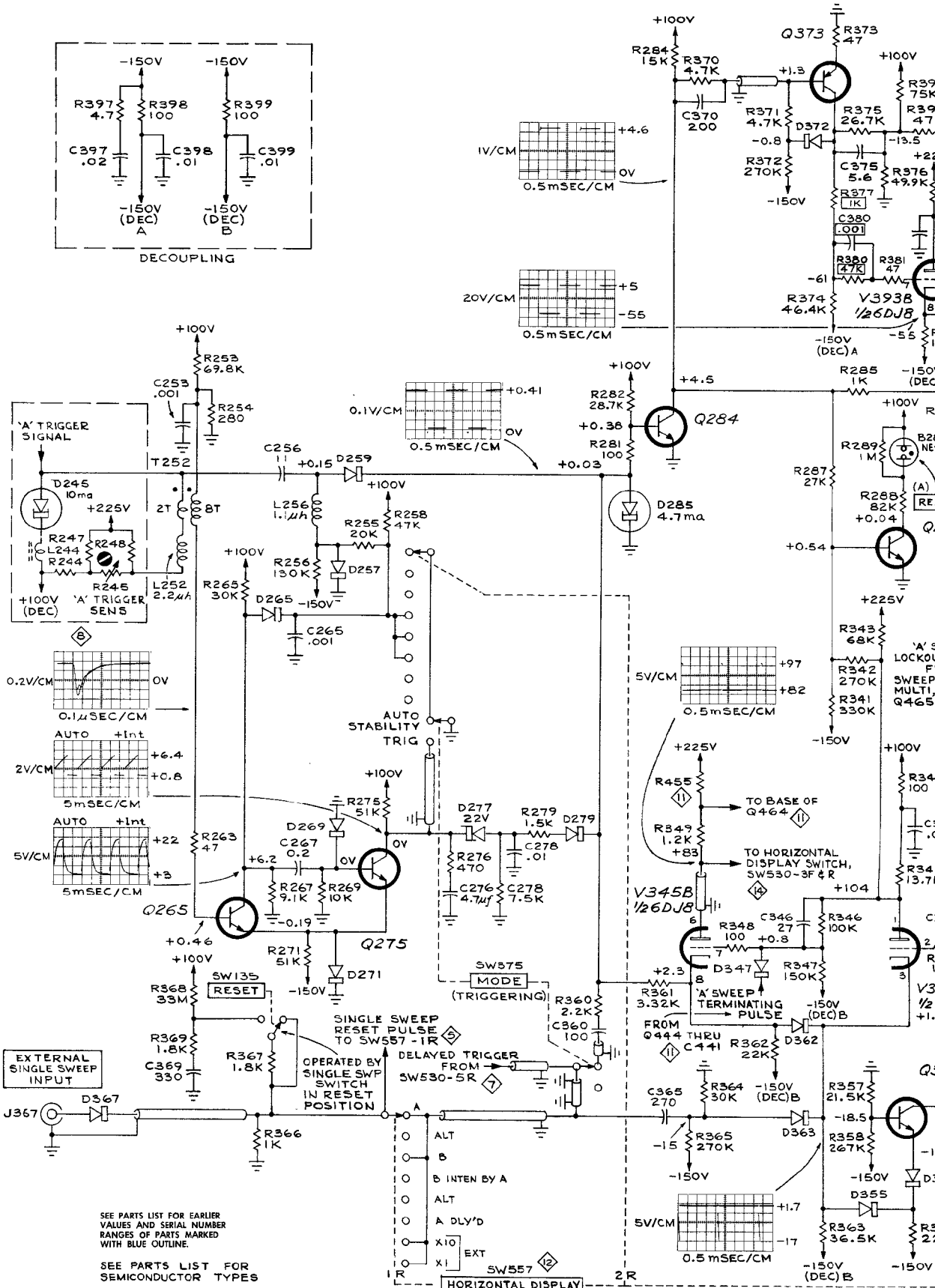
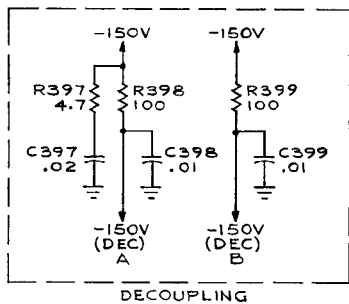

SEE PARTS LIST FOR EARLIER VALUES AND SERIAL NUMBER RANGES OF PARTS MARKED WITH BLUE OUTLINE.

SEE PARTS LIST FOR SEMICONDUCTOR TYPES

† TYPE 547 OSCILLOSCOPE

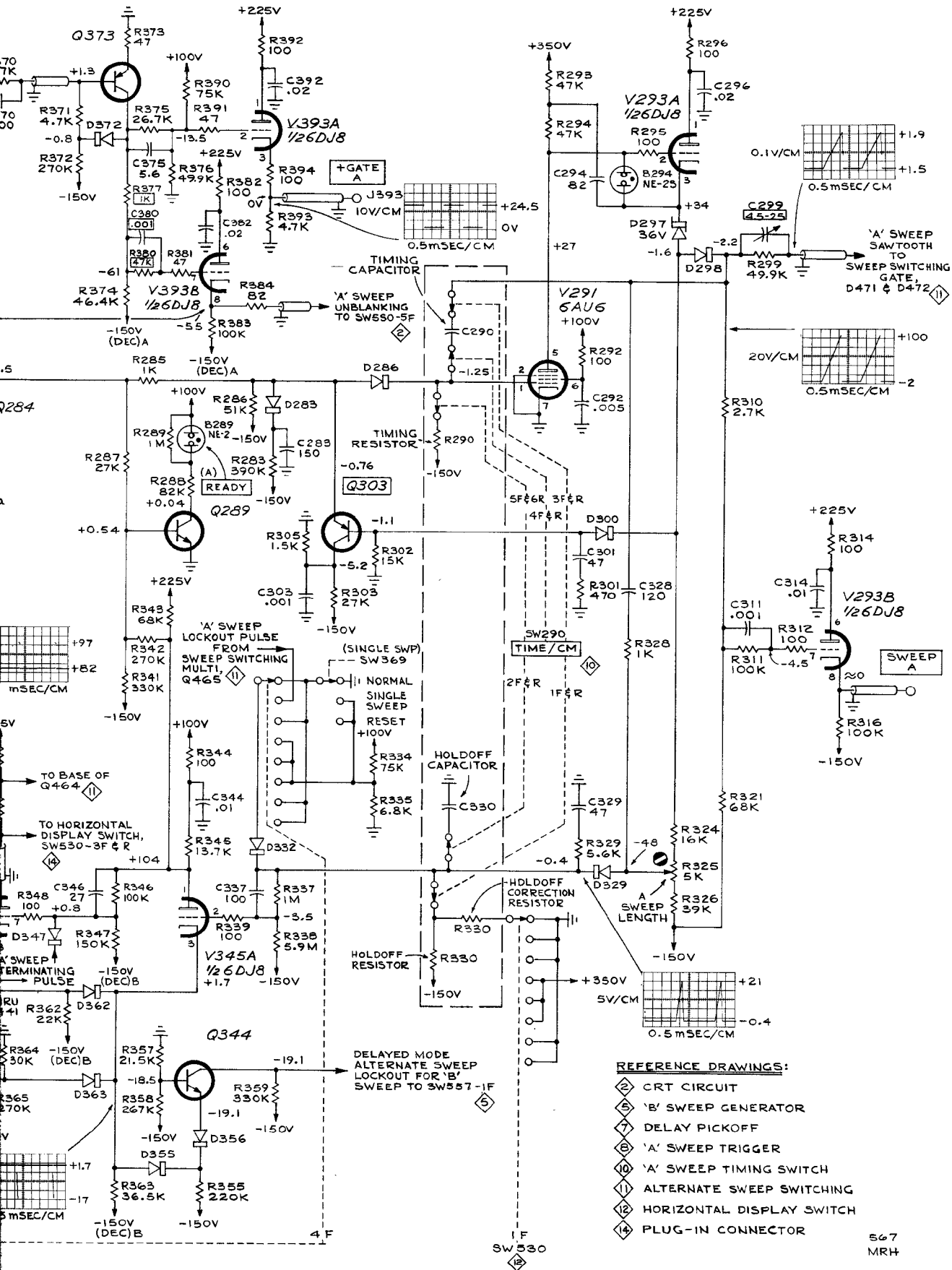

E₁

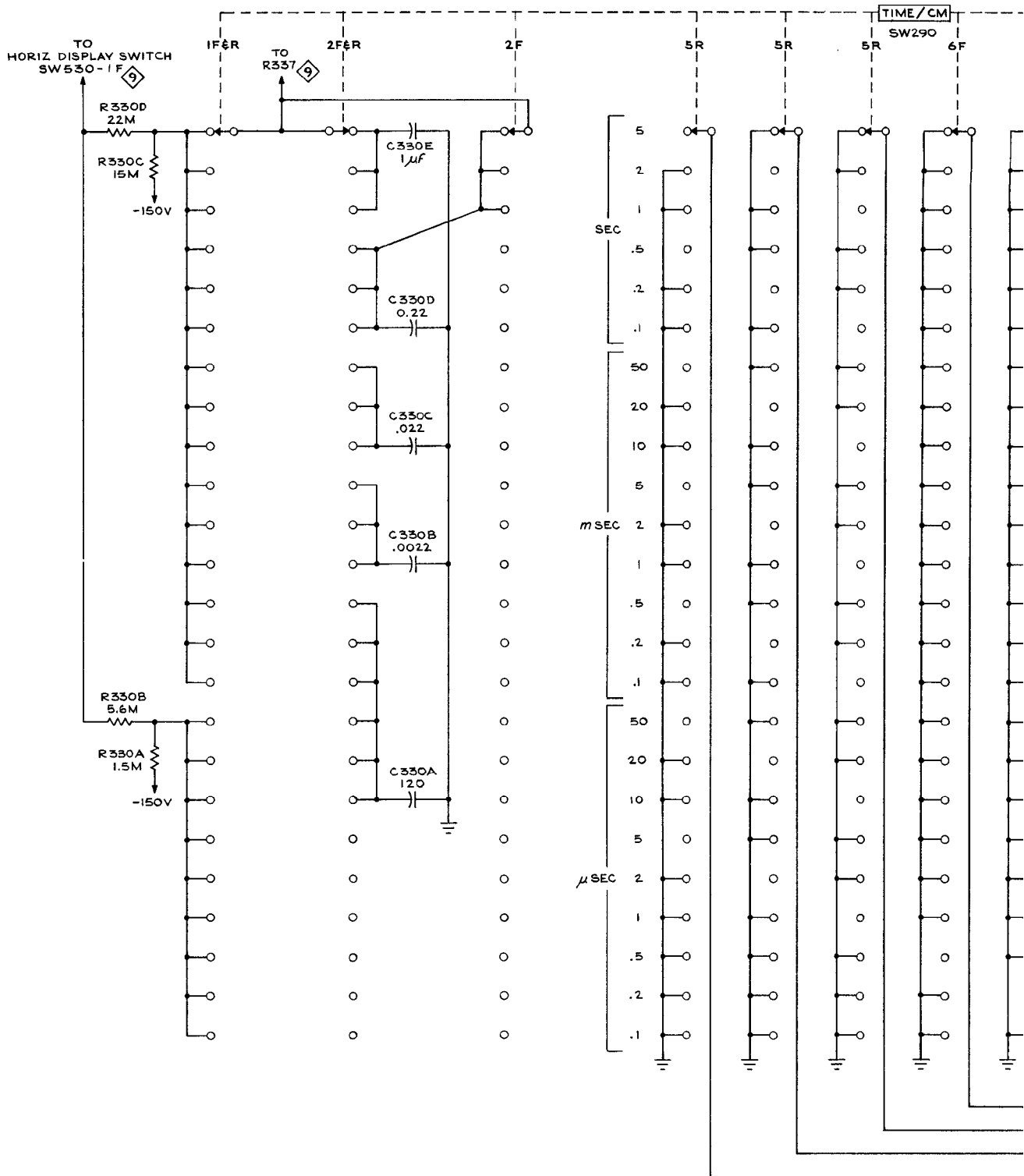

REFERENCE DRAWINGS

9 'A' SWEEP GENERATOR

SEE PARTS LIST FOR EARLIER VALUES AND SERIAL NUMBER RANGES OF PARTS MARKED WITH BLUE OUTLINE.



TYPE 547 OSCILLOSCOPE

REV. D, JAN. 1964

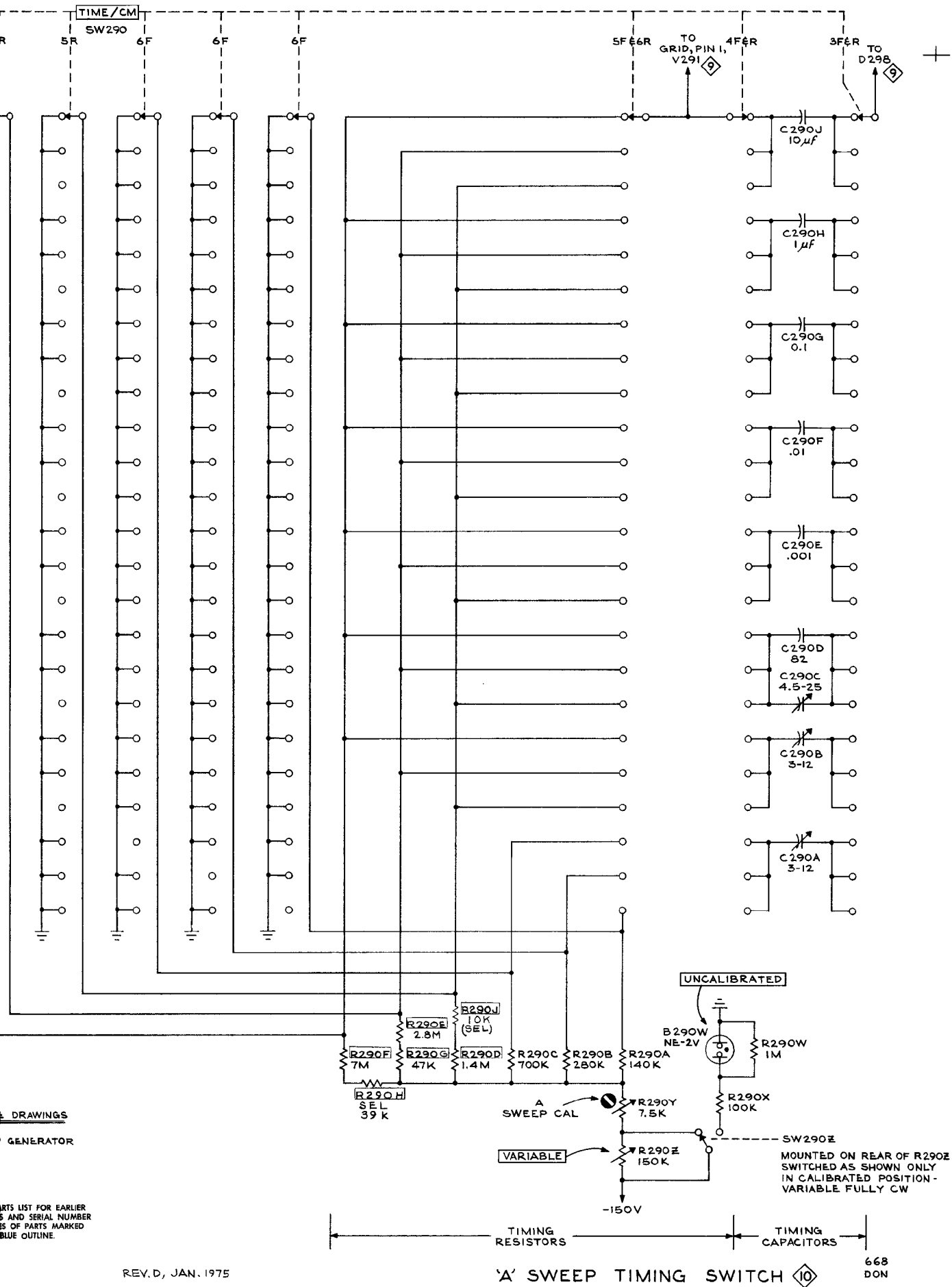

REV. D, JAN. 1975

ALTERNATE SWEEP SWITCHING

WAVEFORMS AND VOLTAGE READINGS were obtained under the following conditions:

TIME BASE A and MAIN TIME BASE (B) —

'A' TRIGGERING LEVEL	ccw; pushed in
'B' TRIGGERING LEVEL	+45°; pushed in
'A' and 'B' TRIGGERING SLOPE	+
'A' and 'B' TRIGGERING COUPLING	AC
'A' TIME/CM5 mSEC
'B' TIME/CM	1 mSEC
'A' and 'B' VARIABLE (TIME/CM)	CALIBRATED
Single Sweep Switch	NORMAL
DELAY-TIME MULTIPLIER	2.00
HORIZONTAL POSITION	Centered
VERNIER (HORIZONTAL POSITION) ..	ccw
POWER	ON

WAVEFORM CONDITIONS

TRACE ROTATION	Fully cw
'A' TRIGGERING MODE	AUTO
'B' TRIGGERING MODE	TRIG
'A' and 'B' TRIGGERING SOURCE ...	LINE (60 cps)
HORIZONTAL DISPLAY*	ALT B INTENS BY 'A'/ALT/A DLY'D

*Exception: See waveform at collector of Q454.

QUIESCENT VOLTAGE CONDITIONS —

'A' TRIGGER INPUT Signal	None
TRACE ROTATION	0
'A' and 'B' TRIGGERING MODE	TRIG
'A' and 'B' TRIGGERING SOURCE ...	EXT
HORIZONTAL DISPLAY	B

Also see IMPORTANT note on "A or B or External Mode" Block diagram.

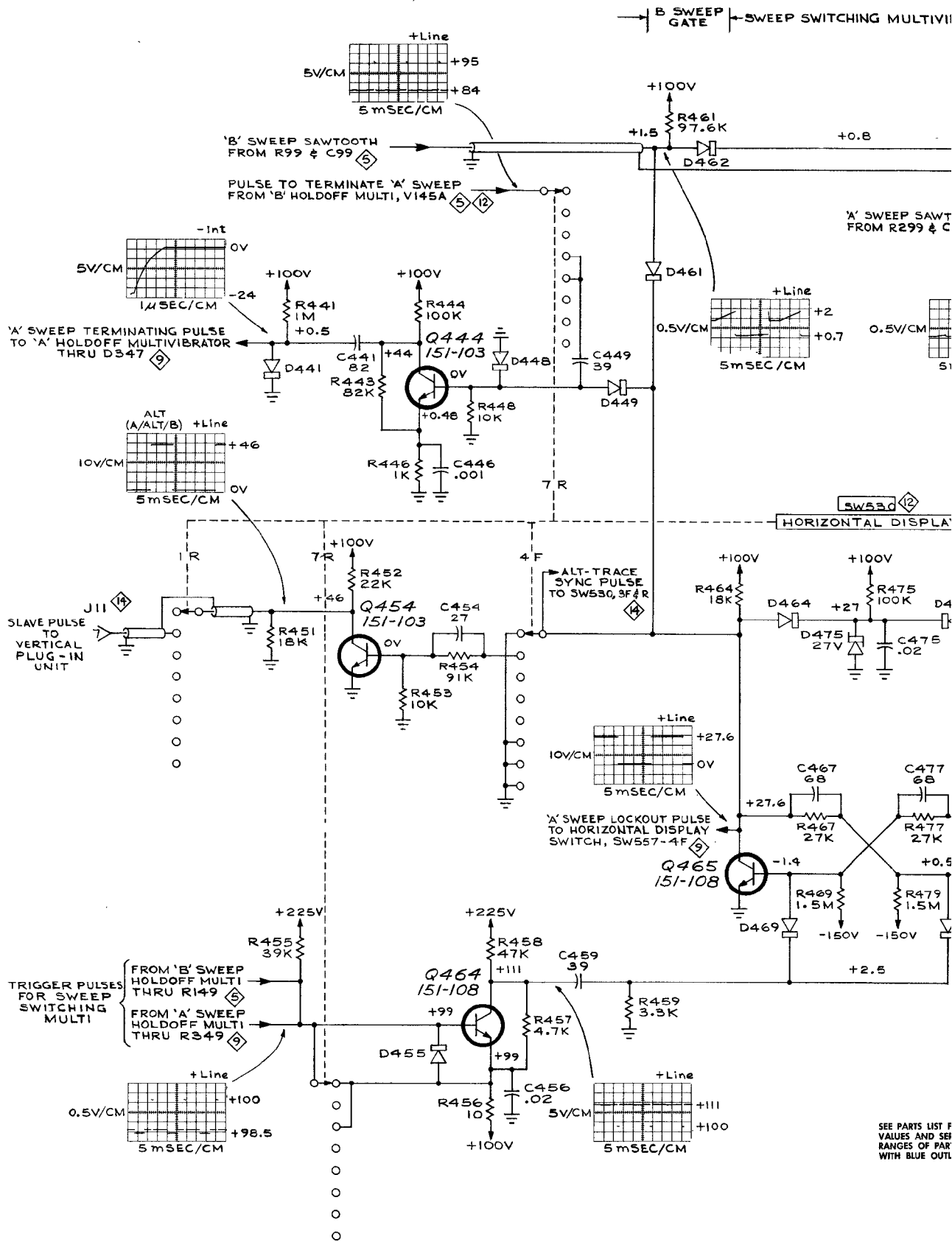

TYPE 547 OSCILLOSCOPE

← SWEEP SWITCHING MULTIVIBRATOR → A SWEEP GATE → TRACE SEPARATION AMPLIFIER →

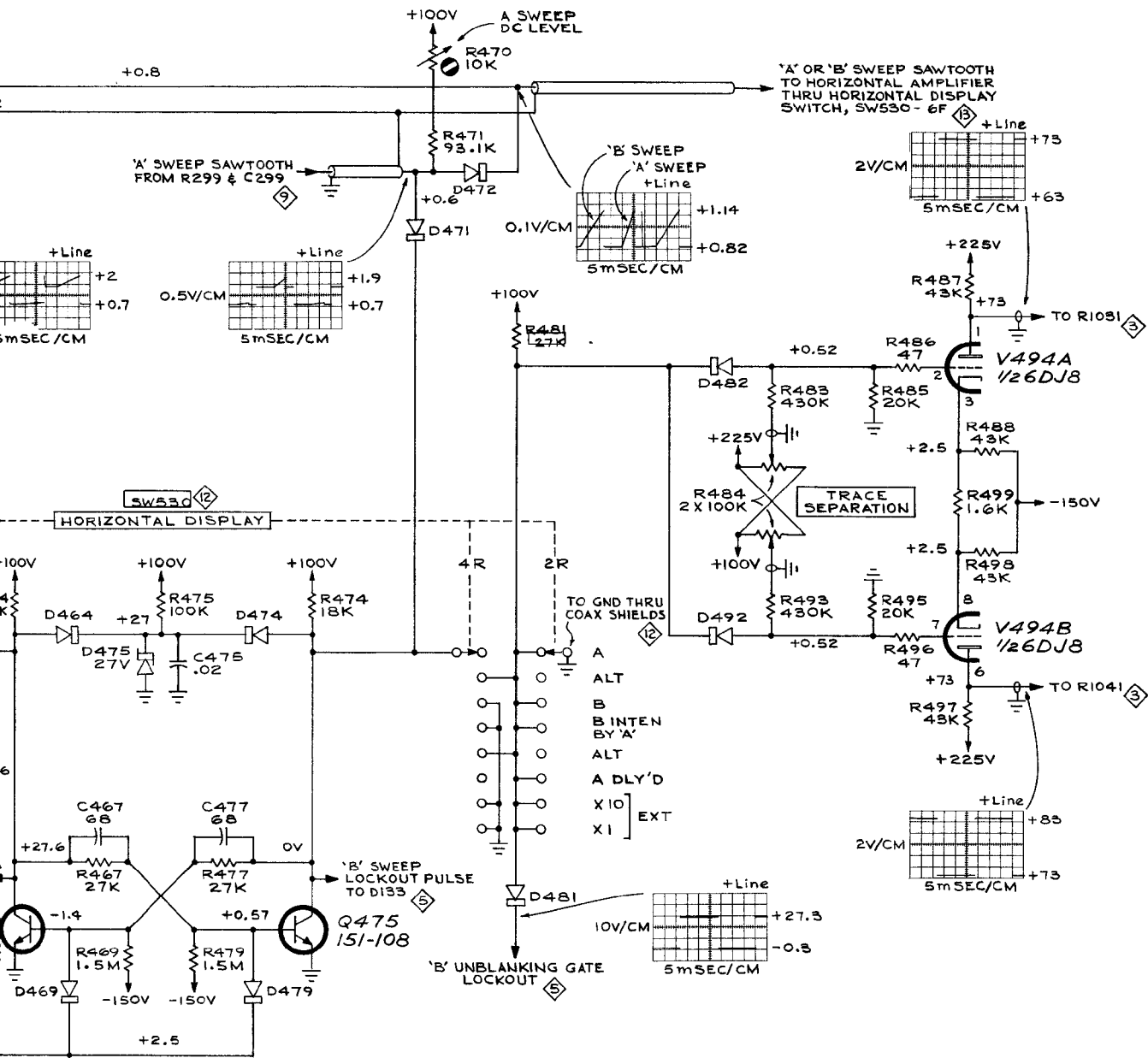

SEE PARTS LIST FOR EARLIER VALUES AND SERIAL NUMBER RANGES OF PARTS MARKED WITH BLUE OUTLINE.

- REFERENCE DRAWINGS:**
- ③ VERTICAL AMPLIFIER
 - ⑤ 'B' SWEEP GENERATOR
 - ⑨ 'A' SWEEP GENERATOR
 - ⑫ HORIZONTAL DISPLAY SWITCH
 - ⑬ HORIZONTAL AMPLIFIER
 - ⑭ PLUG-IN CONNECTOR

C1

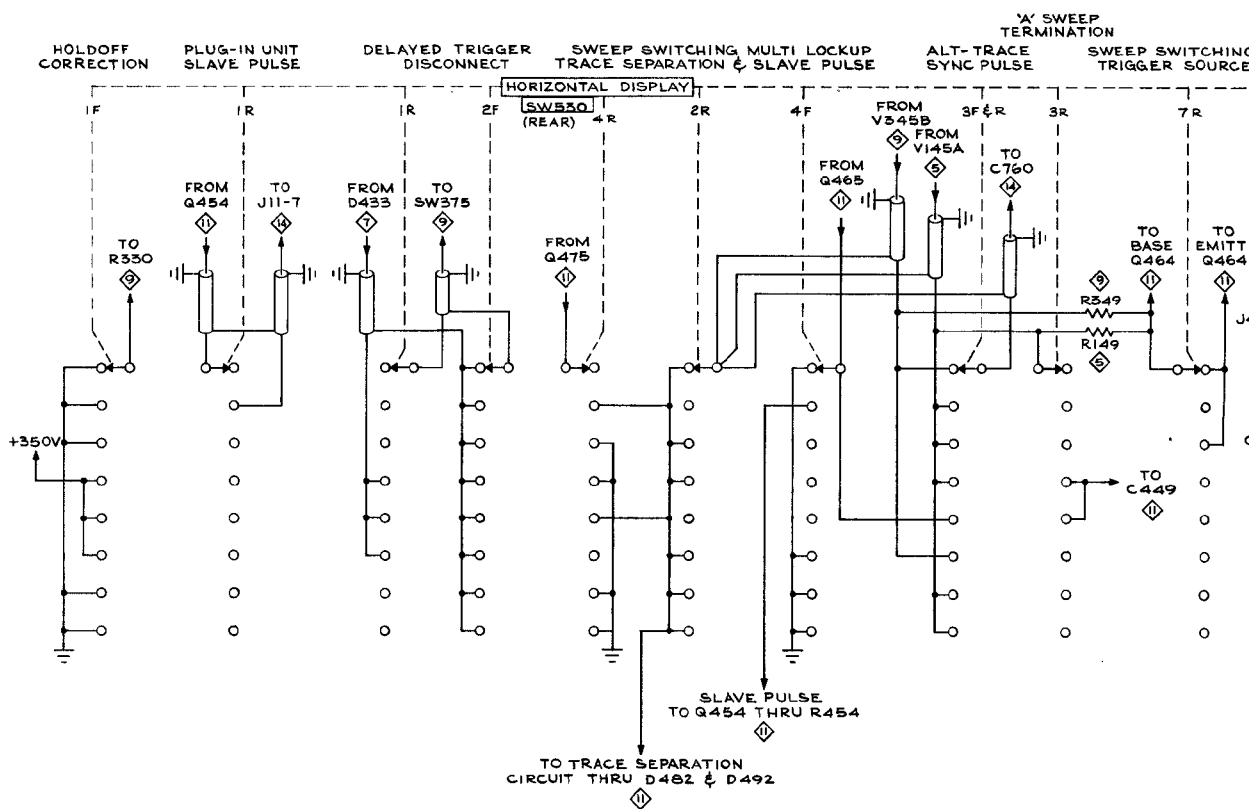
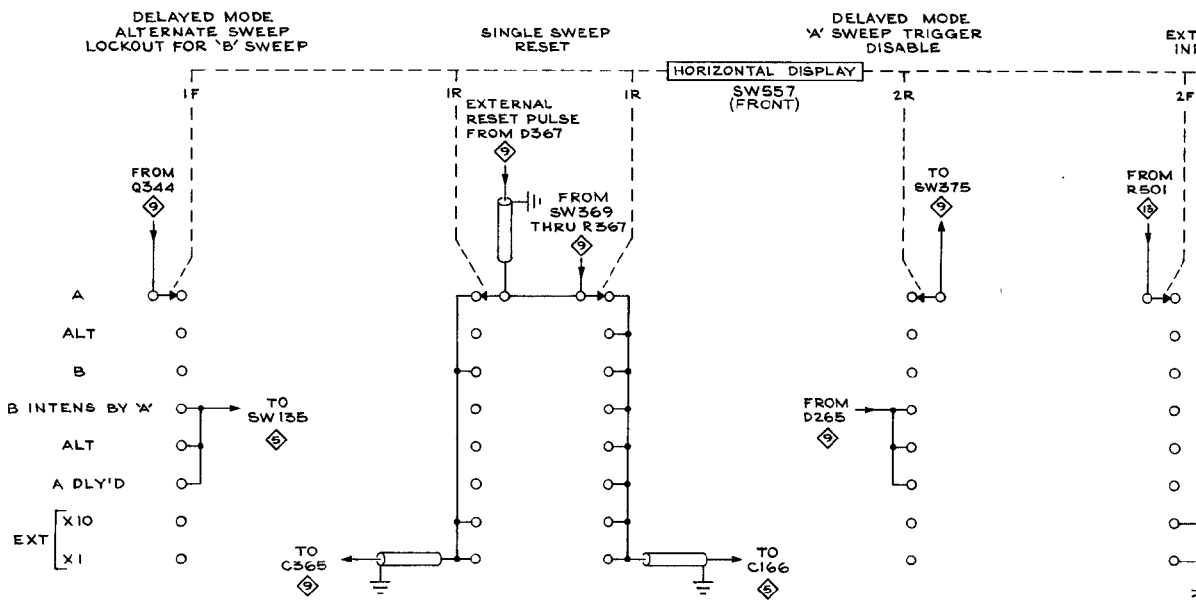

REFERENCE DRAWINGS

- ⊠ CRT CIRCUIT
- ⊡ 'B' SWEEP GENERATOR
- ⊢ DELAY PICKOFF
- ⊣ 'A' SWEEP GENERATOR
- ⊤ ALTERNATE SWEEP SWITCHING
- ⊥ HORIZONTAL AMPLIFIER
- ⊦ PLUG-IN CONNECTOR

+

TYPE 547 OSCILLOSCOPE

SEE P
VALU
RANG
WITH

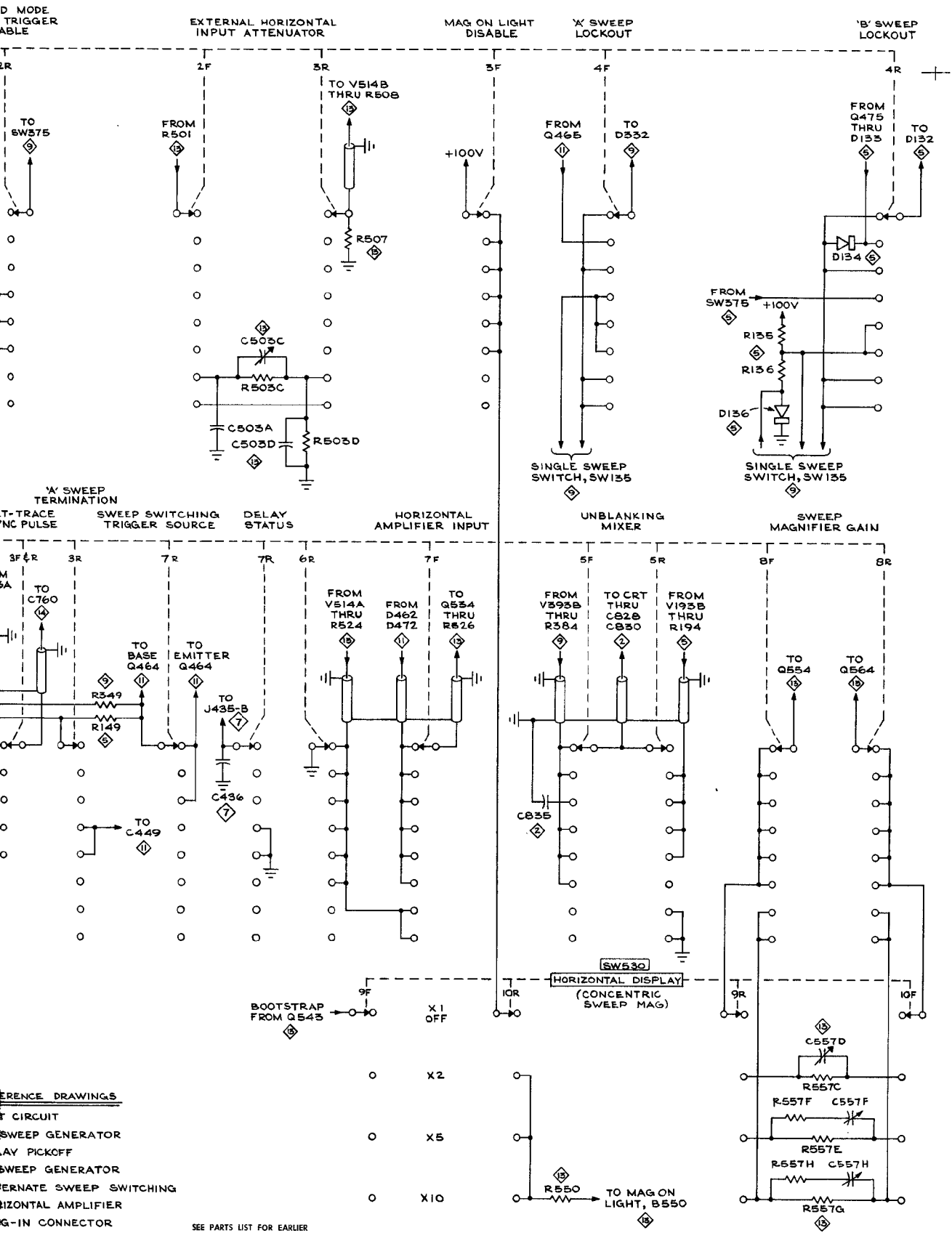

SEE PARTS LIST FOR EARLIER VALUES AND SERIAL NUMBER RANGES OF PARTS MARKED WITH BLUE OUTLINE.

B₁

HORIZONTAL DISPLAY SWITCH 12 DON 866

HORIZONTAL AMPLIFIER

WAVEFORM AND VOLTAGE READINGS were obtained under the following conditions:

MAIN TIME BASE (B) —

TRIGGERING LEVEL	+45°; pushed in
TRIGGERING:	
MODE	TRIG
SLOPE	+
COUPLING	AC
SOURCE	EXT
TIME/CM1 mSEC/CM
VARIABLE (TIME/CM)	CALIBRATED
SWEEP MAGNIFIER	X1
HORIZONTAL POSITION (VERNIER) ..	ccw

POWER

POWER	ON
-------------	----

WAVEFORM CONDITIONS —

'B' TRIGGER INPUT Signal	10 Volts P-P Calibrator
AMPLITUDE CALIBRATOR	10 Volts
HORIZONTAL DISPLAY	B
SWEEP MAGNIFIER	X1
HORIZONTAL POSITION	Centered

QUIESCENT VOLTAGE CONDITIONS —

HORIZ INPUT Signal	None
HORIZONTAL DISPLAY	Ext X1
HORIZONTAL POSITION:	
Upper Voltage Readings	ccw
Lower Voltage Readings	cw

Also see IMPORTANT note on "A or B or External Mode" Block diagram.

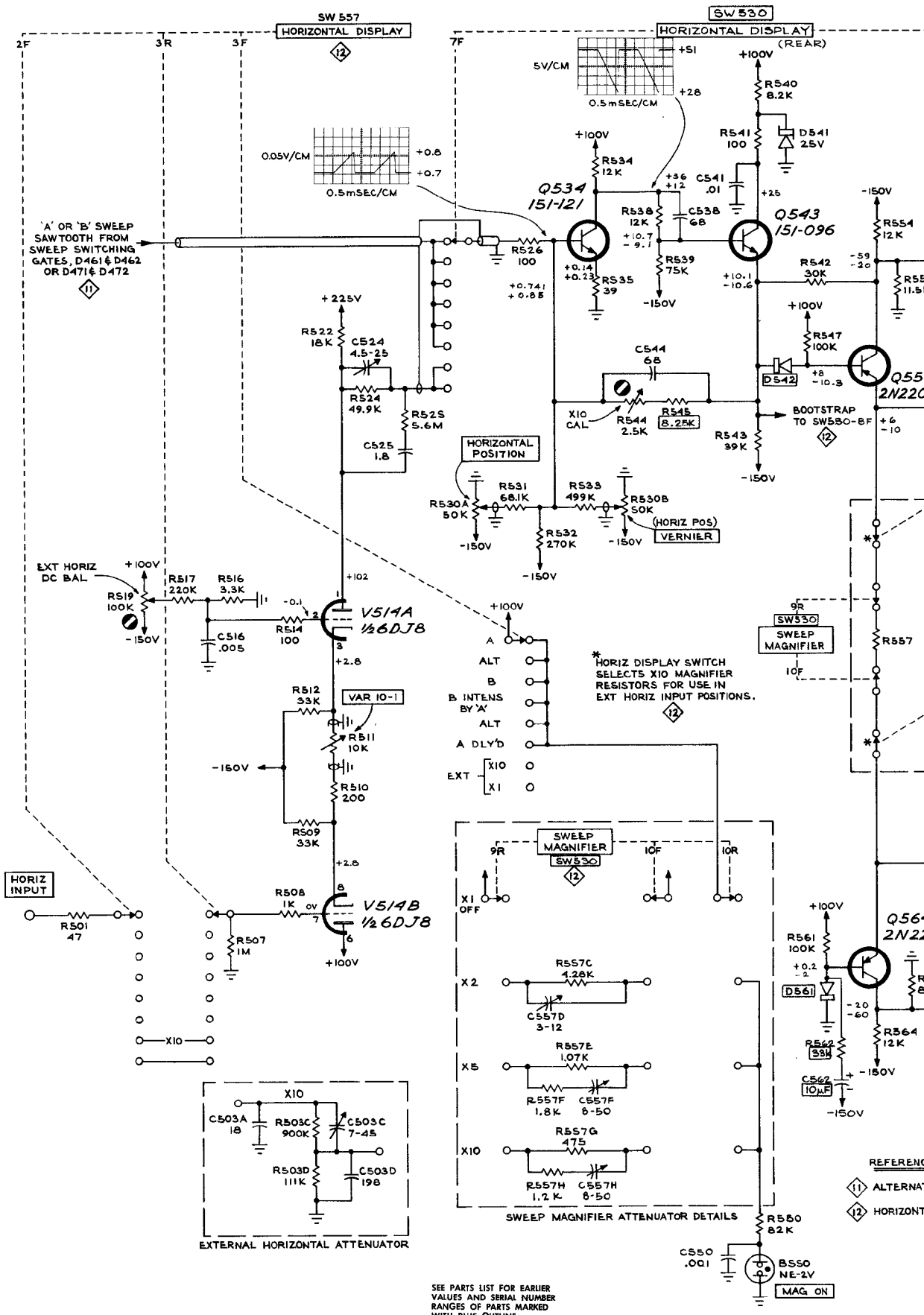

TYPE 547 OSCILLOSCOPE

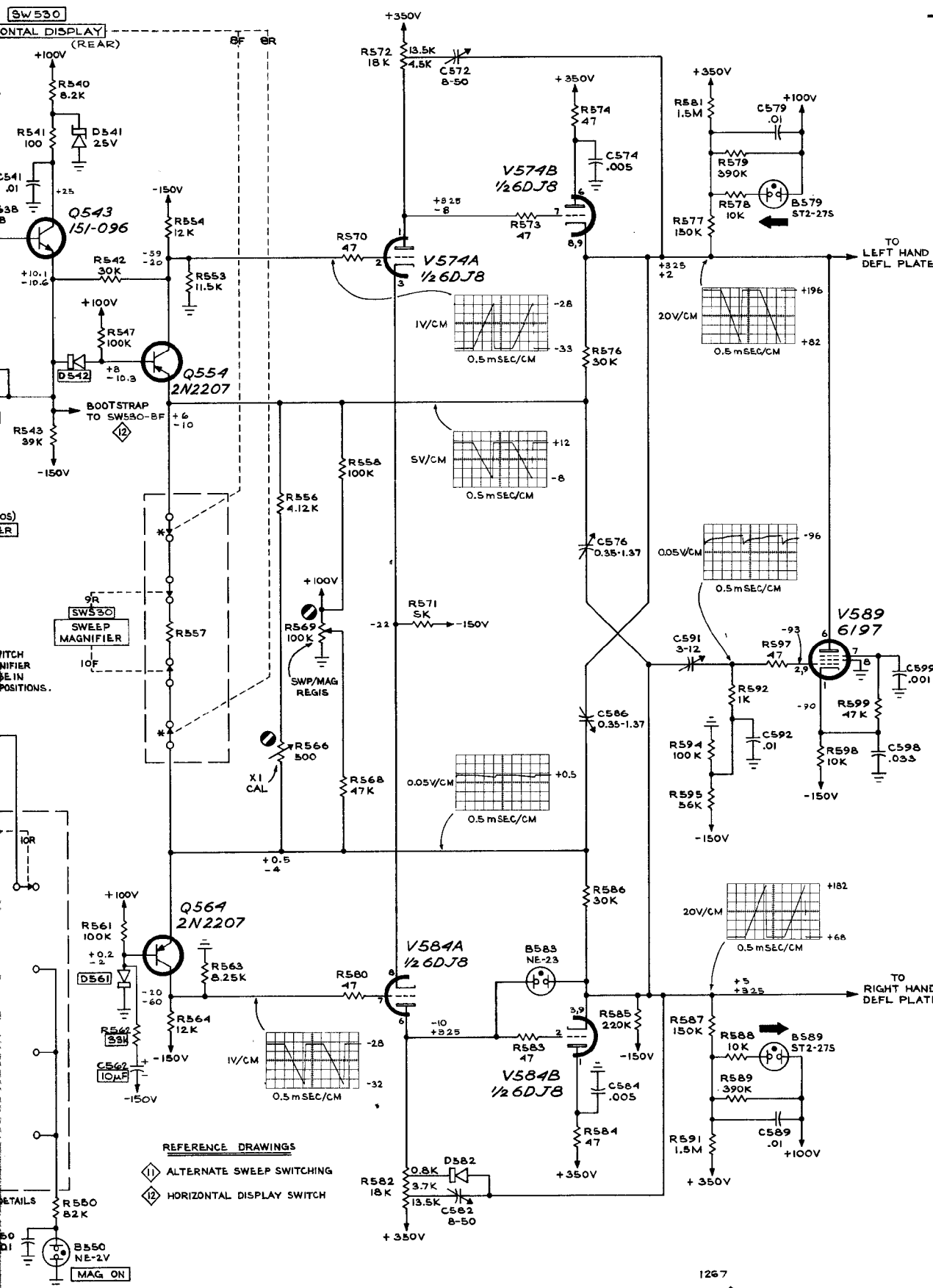

- REFERENCE DRAWINGS
- 1 ALTERNATE SWEEP SWITCHING
 - 2 HORIZONTAL DISPLAY SWITCH

HORIZONTAL AMPLIFIER

1267

D2

SYNC AMP.

WAVEFORM AND VOLTAGE READINGS were obtained under the following conditions:

HORIZONTAL DISPLAY B

SINGLE SWEEP Switch NORMAL

MAIN TIME BASE (B) —

TRIGGER INPUT Signal None
TRIGGERING LEVEL cw
TRIGGERING SOURCE EXT
TIME/CM 50 μ SEC
VARIABLE CALIBRATED

POWER ON

WAVEFORM CONDITIONS —

'B' TRIGGERING MODE AUTO

QUIESCENT VOLTAGE CONDITIONS —

'B' TRIGGERING MODE TRIG

Also see IMPORTANT note on "A or B or External Mode" Block diagram.

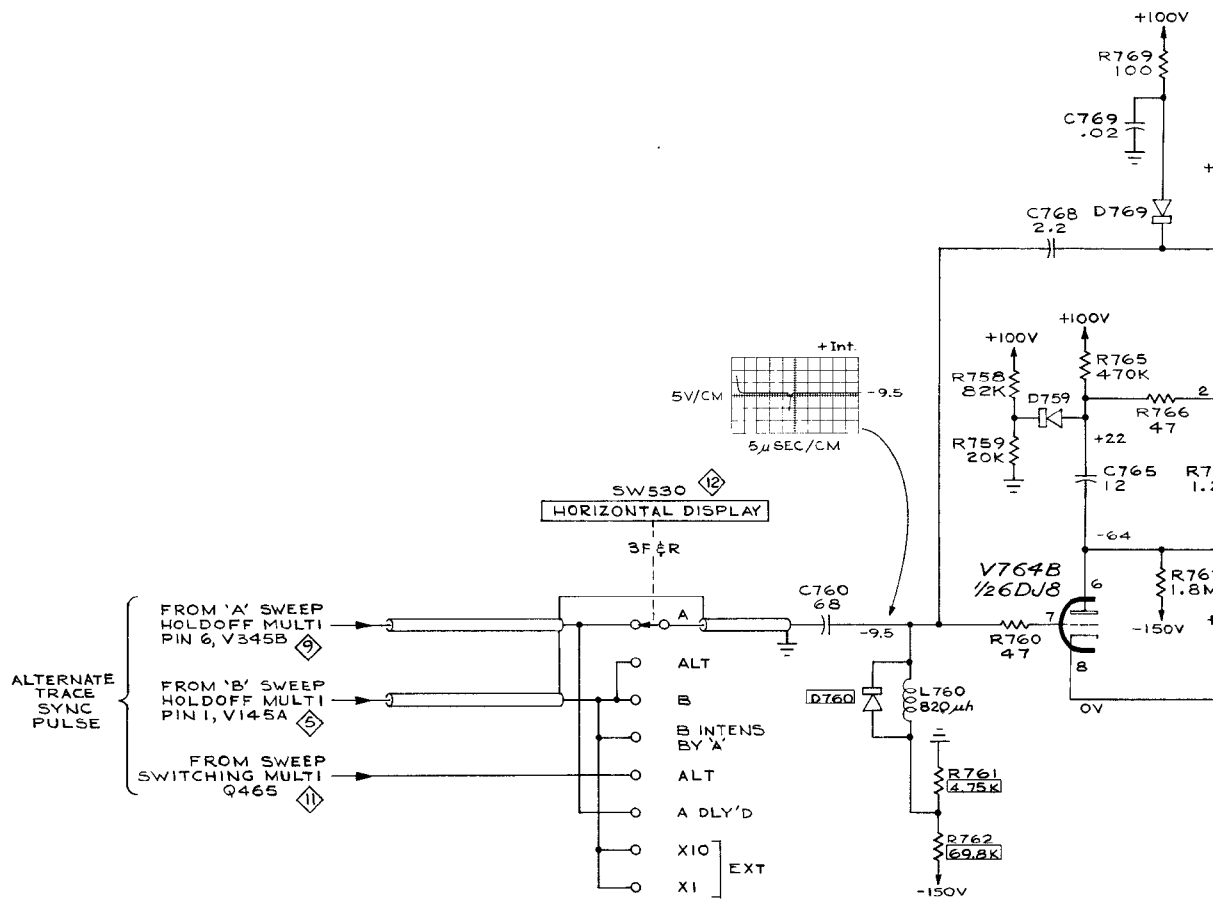

REFERENCE DRAWINGS:

- ① POWER SUPPLY & HEATER WIRING DIAG
- ② CRT CIRCUIT
- ③ VERTICAL AMPLIFIER
- ④ 'B' SWEEP TRIGGER
- ⑤ 'B' SWEEP GENERATOR
- ⑧ 'A' SWEEP TRIGGER
- ⑨ 'A' SWEEP GENERATOR
- ⑪ ALTERNATE SWEEP SWITCHING
- ⑫ HORIZONTAL DISPLAY SWITCH

SEE PARTS LIST FOR SEMICONDUCTOR TYPES

SEE PARTS LIST FOR EARLIER VALUES AND SERIAL NUMBER RANGES OF PARTS MARKED WITH BLUE OUTLINE.

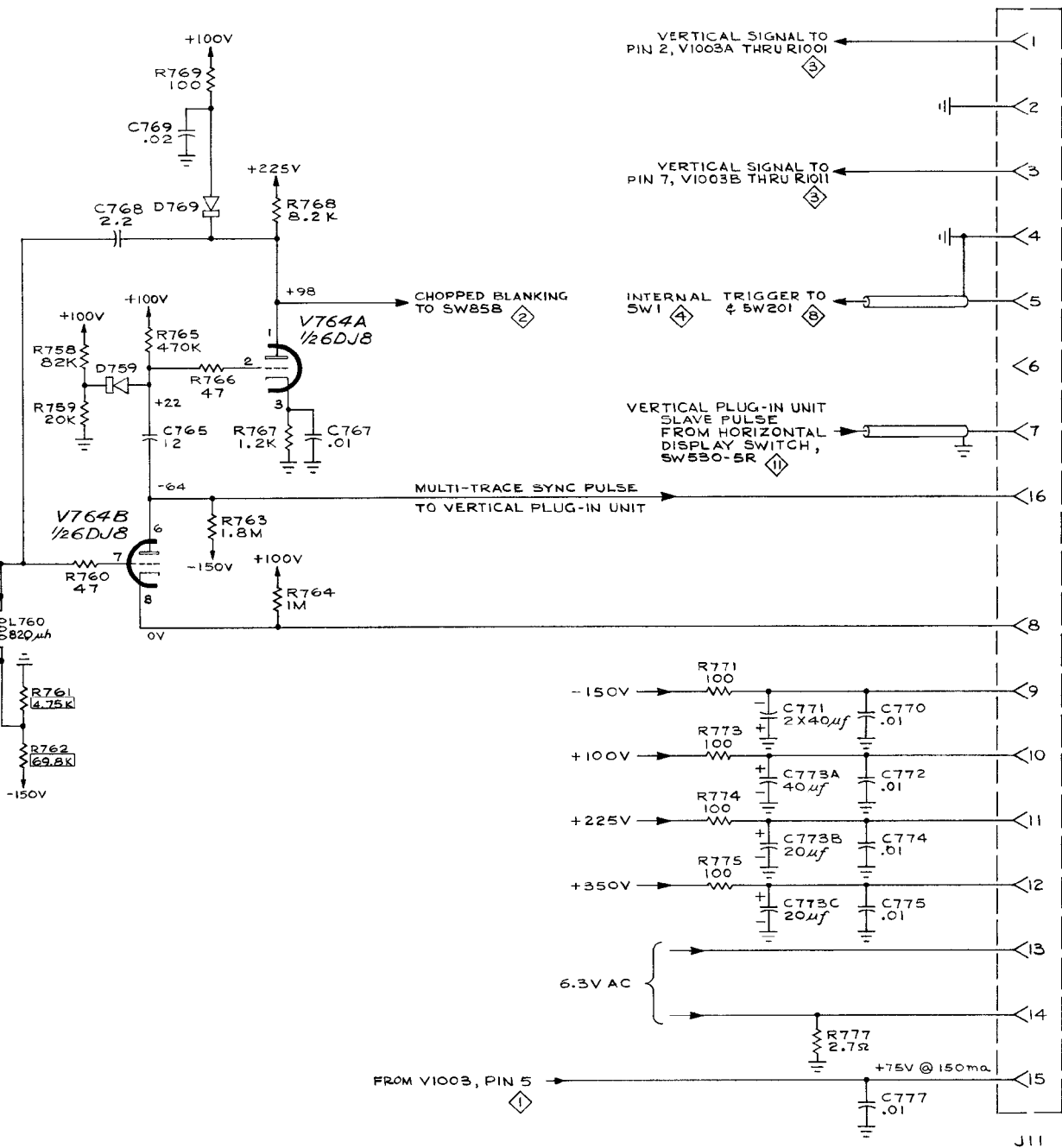

B₁

MR4
565
PLUG-IN CONNECTOR ④

CALIBRATOR

WAVEFORM AND DYNAMIC VOLTAGE READINGS were obtained under the following conditions:

AMPLITUDE CALIBRATOR 10 Volts

POWER ON

Also see IMPORTANT note on "A or B or External Mode" Block diagram.

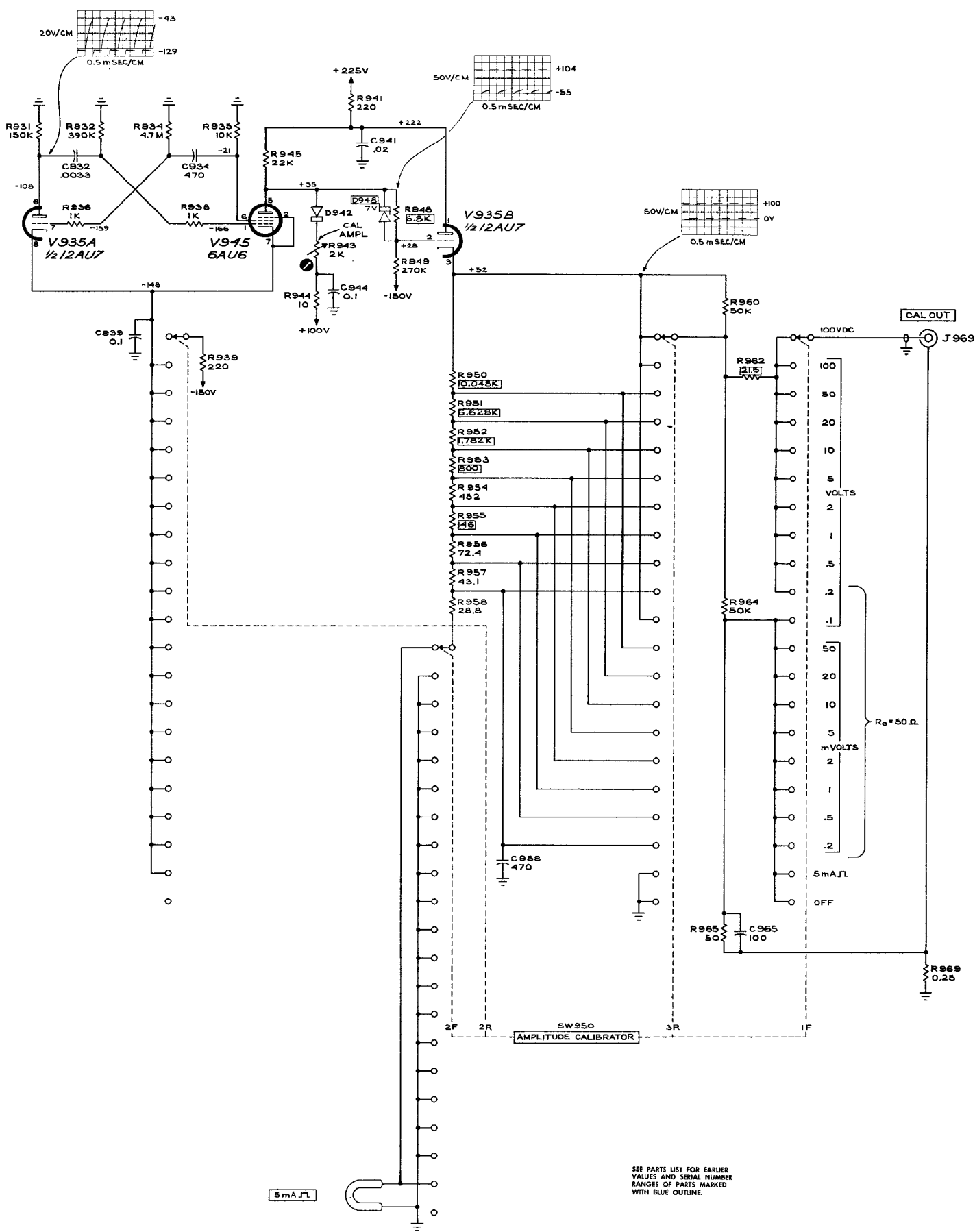

TYPE 547 OSCILLOSCOPE

SEE PARTS LIST FOR EARLIER VALUES AND SERIAL NUMBER RANGES OF PARTS MARKED WITH BLUE OUTLINE.

MANUAL CHANGE INFORMATION

At Tektronix, we continually strive to keep up with latest electronic developments by adding circuit and component improvements to our instruments as soon as they are developed and tested.

Sometimes, due to printing and shipping requirements, we can't get these changes immediately into printed manuals. Hence, your manual may contain new change information on following pages.

A single change may affect several sections. Since the change information sheets are carried in the manual until all changes are permanently entered, some duplication may occur. If no such change pages appear following this page, your manual is correct as printed.

SERVICE NOTE

Because of the universal parts procurement problem, some electrical parts in your instrument may be different from those described in the Replaceable Electrical Parts List. The parts used will in no way alter or compromise the performance or reliability of this instrument. They are installed when necessary to ensure prompt delivery to the customer. Order replacement parts from the Replaceable Electrical Parts List.

CALIBRATION TEST EQUIPMENT REPLACEMENT

Calibration Test Equipment Chart

This chart compares TM 500 product performance to that of older Tektronix equipment. Only those characteristics where significant specification differences occur, are listed. In some cases the new instrument may not be a total functional replacement. Additional support instrumentation may be needed or a change in calibration procedure may be necessary.

Comparison of Main Characteristics

DM 501 replaces 7D13		
PG 501 replaces 107 108	PG 501 - Risetime less than 3.5 ns into 50 Ω . PG 501 - 5 V output pulse; 3.5 ns Risetime	107 - Risetime less than 3.0 ns into 50 Ω . 108 - 10 V output pulse 1 ns Risetime
PG 502 replaces 107 108 111	PG 502 - 5 V output PG 502 - Risetime less than 1 ns; 10 ns Pretrigger pulse delay	108 - 10 V output 111 - Risetime 0.5 ns; 30 to 250 ns Pretrigger pulse delay
PG 508 replaces 114 115 2101	Performance of replacement equipment is the same or better than equipment being replaced.	
PG 506 replaces 106 067-0502-01	PG 506 - Positive-going trigger output signal at least 1 V; High Amplitude output, 60 V. PG 506 - Does not have chopped feature.	106 - Positive and Negative-going trigger output signal, 50 ns and 1 V; High Amplitude output, 100 V. 0502-01 - Comparator output can be alternately chopped to a reference voltage.
SG 503 replaces 190, 190A, 190B 191 067-0532-01	SG 503 - Amplitude range 5 mV to 5.5 V p-p. SG 503 - Frequency range 250 kHz to 250 MHz.	190B - Amplitude range 40 mV to 10 V p-p. 0532-01 - Frequency range 65 MHz to 500 MHz.
SG 504 replaces 067-0532-01 067-0650-00	SG 504 - Frequency range 245 MHz to 1050 MHz.	0532-01 - Frequency range 65 MHz to 500 MHz.
TG 501 replaces 180, 180A 181 184 2901	TG 501 - Trigger output-slaved to marker output from 5 sec through 100 ns. One time-mark can be generated at a time. TG 501 - Trigger output-slaved to market output from 5 sec through 100 ns. One time-mark can be generated at a time. TG 501 - Trigger output-slaved to marker output from 5 sec through 100 ns. One time-mark can be generated at a time.	180A - Trigger pulses 1, 10, 100 Hz; 1, 10, and 100 kHz. Multiple time-marks can be generated simultaneously. 181 - Multiple time-marks 184 - Separate trigger pulses of 1 and 0.1 sec; 10, 1, and 0.1 ms; 10 and 1 μ s. 2901 - Separate trigger pulses, from 5 sec to 0.1 μ s. Multiple time-marks can be generated simultaneously.

NOTE: All TM 500 generator outputs are short-proof. All TM 500 plug-in instruments require TM 500-Series Power Module.



TEKTRONIX®

committed to
technical excellence

MANUAL CHANGE INFORMATION

PRODUCT 547
070-0398-00

CHANGE REFERENCE C1/376
DATE 3-15-76

CHANGE:	DESCRIPTION
---------	-------------

SCHMATIC CORRECTIONS

The serial numbers (6740 & U) given on Diagrams 5 and 9 are not correct. The diagrams with the above serial number are for instruments serial numbered 12840 and up.

These diagrams also apply to serial numbers between 6740 and 12839 except for the following:

1. Q86 and Q286 are not in these units, the circuitry at this point is like that shown for serial numbers 100 to 6739.

2. In the absence of Q86 and Q286, resistors R91, R97, R297, and R298 are not used.

3. R300 and D291 are not in instruments below serial number 12839.

In cases of doubt, go by the serial number ranges given in the Electrical Parts List.