

TEKTRONIX®

DM 502

DIGITAL

MULTIMETER

INSTRUCTION MANUAL

TEKTRONIX®

DM 502

DIGITAL

MULTIMETER

INSTRUCTION MANUAL

Tektronix, Inc.
P.O. Box 500
Beaverton, Oregon 97005

Serial Number _____



WARRANTY

All TEKTRONIX instruments are warranted against defective materials and workmanship for one year. Any questions with respect to the warranty should be taken up with your TEKTRONIX Field Engineer or representative.

All requests for repairs and replacement parts should be directed to the TEKTRONIX Field Office or representative in your area. This will assure you the fastest possible service. Please include the instrument Type Number or Part Number and Serial Number with all requests for parts or service.

Specifications and price change privileges reserved.

Copyright © 1974 by Tektronix, Inc., Beaverton, Oregon. Printed in the United States of America. All rights reserved. Contents of this publication may not be reproduced in any form without permission of Tektronix, Inc.

U.S.A. and foreign TEKTRONIX products covered by U.S. and foreign patents and/or patents pending.

TEKTRONIX is a registered trademark of Tektronix, Inc.

TABLE OF CONTENTS

	Page
SECTION 1	OPERATING INSTRUCTIONS
	Introduction 1-1
	Instrument Description 1-1
	Installation and Removal 1-1
	Operating Considerations 1-2
	Input Connections 1-2
	Functions Available at Rear Connector 1-2
	Sine Wave Response 1-3
	Temperature Measurements 1-3
	Making Measurements 1-4
	DC Voltage Measurements 1-4
	DC Current Measurements 1-4
	AC Voltage, Current and Resistance Measurements 1-5
	Decibel Measurements 1-5
	Temperature Measurements 1-5
	Using a Transistor as a Temperature-Sensing Device 1-5
	Accurate Current Source 1-6
	Specifications 1-6
SECTION 2	THEORY OF OPERATION
	Introduction 2-1
	Attenuator and Input Switching 2-1
	AC Converter 2-1
	DB Converter 2-1
	Ohms Converter 2-2
	Temperature Measurement Circuitry 2-2
	Clock 2-3
	Analog-To-Digital Converter 2-3
	Display 2-5
	Power Supplies 2-5
SECTION 3	ELECTRICAL REPLACEABLE PARTS LIST
SECTION 4	SERVICE INFORMATION
	Internal Adjustment Procedure
	Rear Interface Connector Assignments
	Rear Interface Connector Wire Locations
	Front Panel Controls and Connectors
	Block Diagram
	Parts Location Grid
	Attenuators and Conversion Circuits Schematic
	Integrator, A/D Converter and Display Schematic
	Power Supply and Switch Logic Schematic
SECTION 5	MECHANICAL REPLACEABLE PARTS LIST
	Accessories
	Repackaging
	Exploded View
CHANGE INFORMATION	

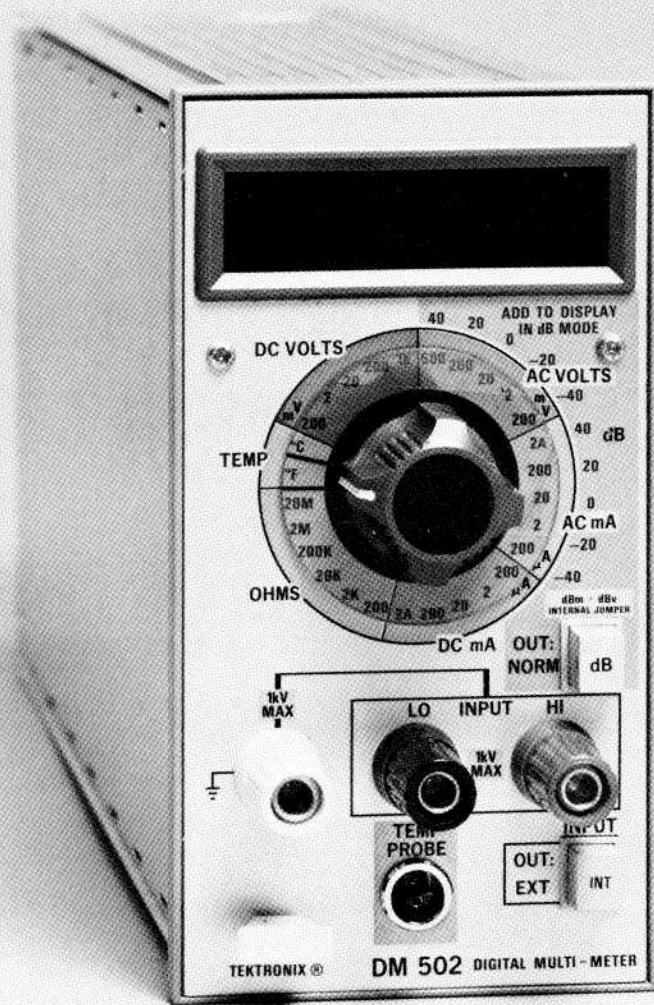

OPERATING INSTRUCTIONS

INTRODUCTION

Instrument Description

The DM 502 Digital Multimeter measures dc and ac voltage and current, dBm, dBV, resistance and temperature. The ac functions are average responding and rms calibrated for sine waves. A single front panel control selects all ranges. A front-panel pushbutton selects dB readout of ac functions in lieu of voltage or current. Rear interface-connector input is also pushbutton selected from the front panel. Values of dB are obtained by adding the selected dB range value to the display reading. Readout in dBm or dBV is chosen by an internal jumper. The unit is shipped with the jumper in the dBm position.

An internal jumper also permits selection of fet input ($> 1000 \text{ M}\Omega$) or $10 \text{ M}\Omega$ input impedance on the two lowest dc-voltage ranges. The unit is shipped with the jumper in the $10 \text{ M}\Omega$ position. See Fig. 1-2.

Temperature measurements are made using a Tektronix P6430 probe (Tektronix Part Number 010-6430-00) or other suitable sensing devices. Option 2 instruments delete the temperature measuring capability.

The readout is a 3-1/2 digit display using seven-segment LED's. The decimal point is automatically positioned by the range-function switch. Polarity indication is automatic. A usable 50% overrange exists in all measurement modes except ac voltage and current, 1000 V dc, and the 2 A dc current range. In overrange, the display blinks and the most significant digit is suppressed. Upon exceeding the available 50% overrange, a 1 appears in the most significant digit position. Display readings are invalid beyond this point.

Interlaced bcd output (1, 3, 2, 4) referenced to the low input, is available at the rear interface connector if user wired.

NOTE

The DM 502 is not directly compatible with the 153 Calculator Interface.

The maximum input voltage is 1 kV , 350 V at the rear connectors. The front-panel HI and LO connectors may be floated 1 kV maximum above ground, the rear inputs 350 V .

Installation and Removal

The DM 502 is calibrated and ready for use when received. It operates in any compartment of a TM 500 series power module. See the power module instruction manual for line voltage requirements and power module operation. Fig. 1-1 shows the DM 502 installation and removal procedure.

CAUTION

Turn the Power Module off before inserting the DM 502. Otherwise, arcing may occur at the rear interface connectors, reducing their useful life and damage may be done to the plug-in circuitry.

Check that the DM 502 is fully inserted in the Power Module. Pull the PWR switch on the Power Module. One or more characters in the LED display should now be visible.

The Controls, Connectors and Adjustments foldout page in Section 3 gives a complete description of the front panel.

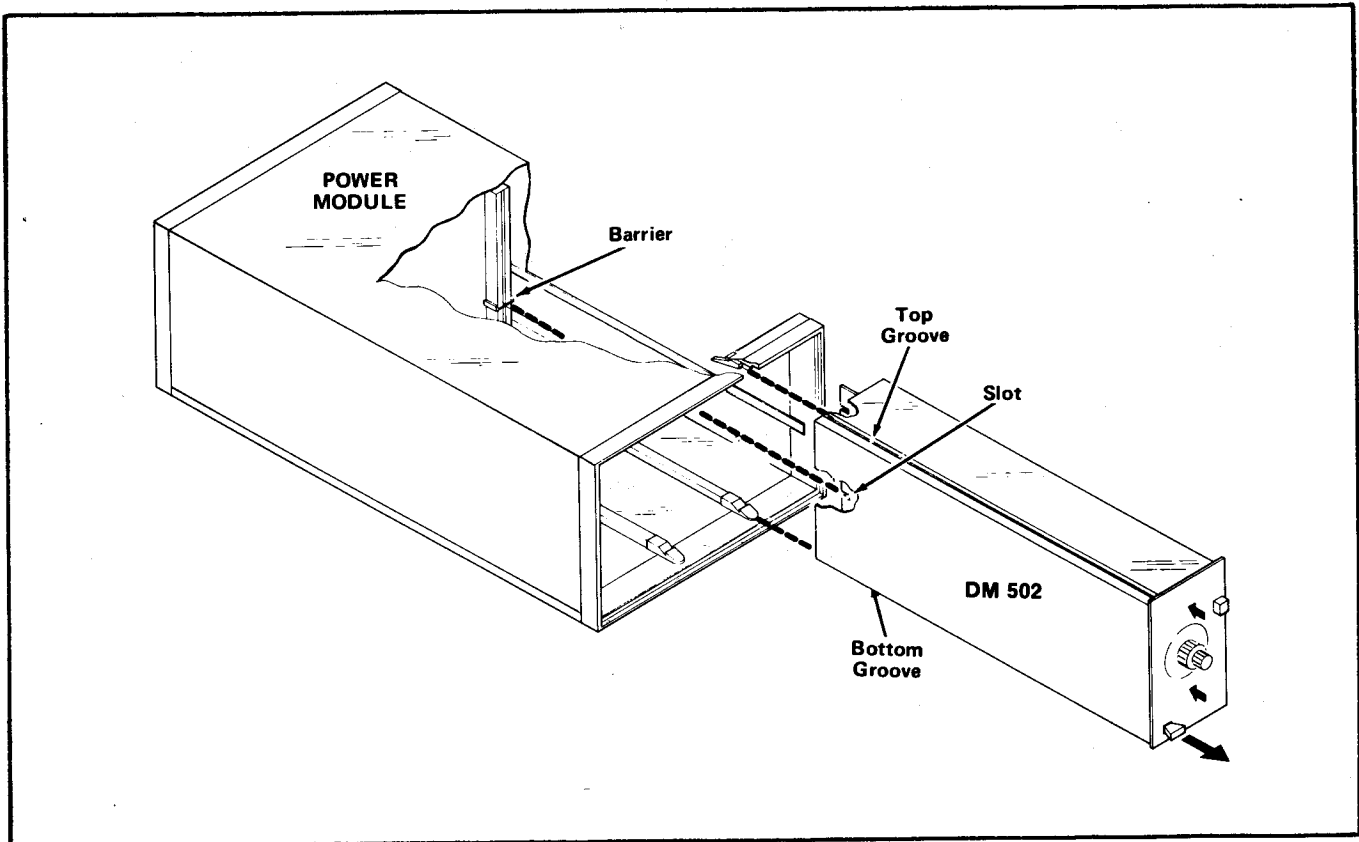

Fig. 1-1. DM 502 Installation and removal.

OPERATING CONSIDERATIONS

Input Connections

Three binding posts provide measurement connections. The HI and LO posts are normally used for all measurements except temperature. Normal measurement conditions will be with the LO terminal ungrounded. A connection between the LO and GND posts may be made to reference the input against DM 502 chassis ground. Use caution, as the LO terminal is then connected to earth ground through the three-wire power cord. False readings may be obtained due to ground loops.

If the INPUT button is pushed in, signal inputs are made via the rear interface connector; if the button is out, signal inputs are made via the front panel.

Functions Available at Rear Connector

HI, LO, GROUND, temperature output at 10 mV per degree and bcd connections are available at the rear

interface connector. The Rear Interface Connector Assignments page in the Service Section at the rear of this manual gives data on the various connections. Only the Temp Out, Temp Gnd and HI and LO inputs are factory-wired. Jumper holes are provided for making the desired bcd output connections. See the wire locations illustration in the foldout pages for the correct circuit board locations. Simply insert and solder an insulated wire strap in the proper locations. Buffers are required before the data outputs are used to drive external loads. See Fig. 1-3 for a typical buffer circuit.

The DM 502 has a slot between pins 17 and 18. A barrier in the corresponding position of the power module jack allows only compatible plug-ins to be used in that compartment. This protects the plug-in, should specialized connections be made to that compartment. Consult the Building A System section of the power module manual for further information.

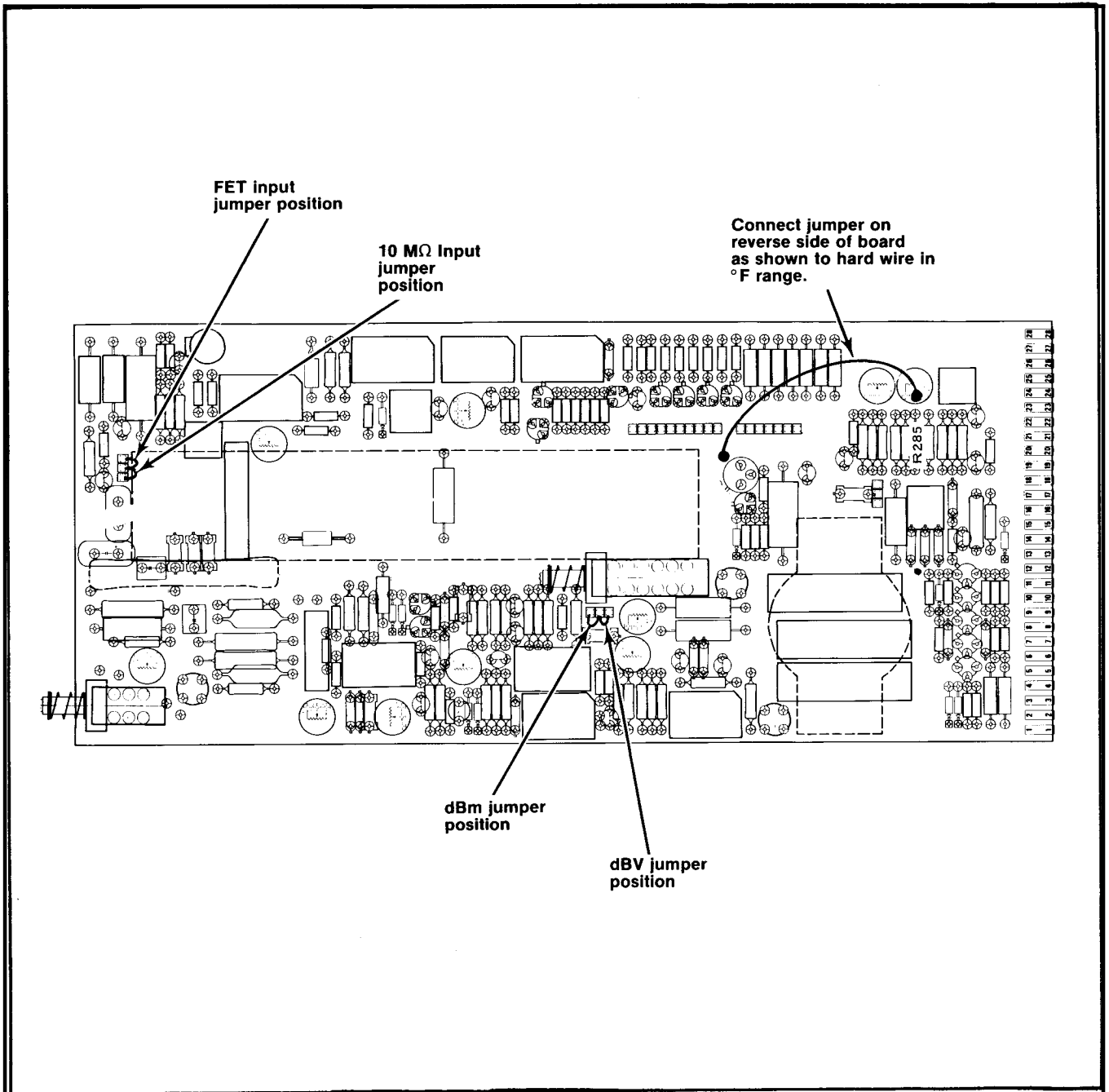

Fig. 1-2. Locations of dB reference jumper, input impedance jumper, and hard wired °C or °F component or wire changes.

Sine-wave Response

The DM 502 responds to the average value of a sinusoidal current or voltage. The readout indicates the equivalent rms value. The effective or rms value of a sine wave is 0.707 times the peak voltage or current. The average value is 0.636 of the peak value. The scale factor of the DM 502 is 0.636/0.707 or 0.9. Multiply the DM 502 readout by 0.9 to obtain the average value of a sinusoidal input voltage or current.

Temperature Measurements

Connect the P6430 (or other sensing device) to the connector marked TEMP PROBE. Use care to align the connector pins properly. Select calibration in °F or °C with the range-function switch. For best accuracy, calibrate the individual instrument to the probe used. See the Internal Adjustment Procedure in the service section of this manual for the proper procedure.

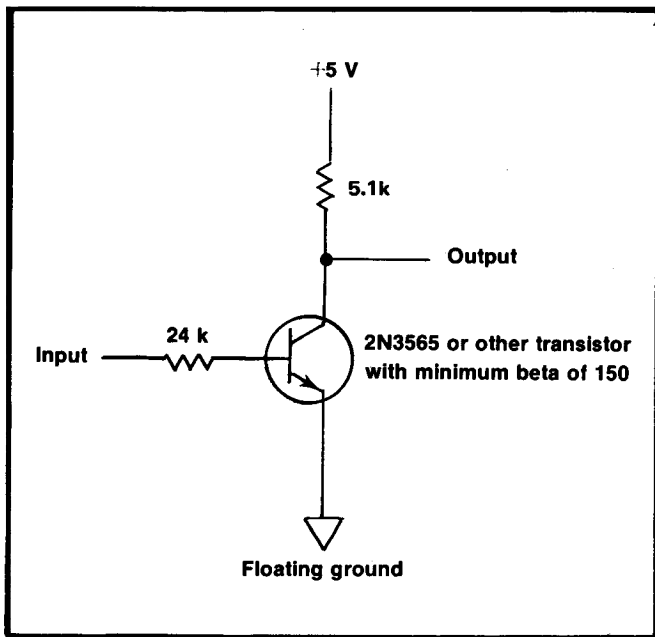

Fig. 1-3. Typical buffer circuit for rear connector data outputs. Up to 20 mA may be used from the DM 502 +5 V supply.

The Temp Out terminals at the rear interface connector are always connected to the output of the temperature circuitry. This feature provides continuous temperature monitoring capabilities in °C even while using other functions of the DM 502. To avoid a momentary scale change when a recorder or other device is connected to these terminals avoid switching through the °F position.

The DM 502 may be hard wired in either the °C or °F range independent of the range-function switch setting. To hard wire in the °F range, connect a jumper as shown in Fig. 1-2. To hard wire in °C lift either end of R285 as shown in Fig. 1-2.

MAKING MEASUREMENTS

With the DM 502 properly installed in the power module, allow twenty minutes warmup time for operation to specified accuracy. When the value of the quantity being measured is unknown, select the highest range first. Decrease the range setting until the display blinks indicating over-range. Then increase the range switch to the next higher position. This method obtains maximum resolution. Resolution of the DM 502 is 0.05% of full scale setting, except temperature, which is 0.1°. Do not exceed the maximum voltage ratings. With the range-function switch in the 1 K DC VOLTS or 500 AC VOLTS position, internal damage may result before overrange is indicated.

CAUTION

To prevent possible damage to switch contacts by high currents, do not switch into, out of, or through the current measurement modes from the other measurement modes with a high current source, or large inductive or capacitive load, connected to the DM 502 input. This caution does not apply to switching between individual current ranges up to the maximum stated input current, as the switch contacts are adequately protected for this operation.

DC Voltage Measurements

Select an appropriate full range dc voltage position with the range-function switch. Apply the voltage to be measured to the INPUT binding posts. Observe the maximum voltage ratings as indicated on the front panel. The readout displays a + if the HI input is positive with respect to the LO input. A — is displayed if the LO input is more positive. With the input shorted, the display reads zero, ± one count.

DC Current Measurements

Select an appropriate full scale DC mA position on the range-function switch. Apply the dc current to be measured to the INPUT binding posts. A current (electron flow) into the LO connector and out of the HI connector indicates + on display. For opposite current flow, a — will be displayed.

AC Voltage, Current and Resistance Measurements

Select an appropriate full scale AC VOLTS, AC mA or OHMS position on the range-function switch. Connect the unknown voltage, current or resistance to the INPUT binding posts.

Decibel Measurements

To use this feature, switch to an ac voltage or current range and push the button marked dB on the front panel. Connect the voltage or current source to the DM 502. To arrive at the correct dB reading, algebraically add the number on the outside scale to the display reading. When the dB switch is depressed, the decimal point is fixed and the maximum display reading is 19.99 on all scales.

For example, if the range-function switch is on the 2 AC VOLTS position and the display reading is +13.98, then the correct dB reading is:

$$\begin{array}{r} +13.98 \\ -20.00 \\ \hline - 6.02 \text{ dB} \end{array}$$

If the range-function switch is on the 200 AC mA position and the display reads -4.04, then:

$$\begin{array}{r} - 4.04 \\ +20.00 \\ \hline +15.96 \text{ dB} \end{array}$$

Selection of dB readout in dBV or dBm is accomplished by a jumper shown in Fig. 1-2. The reference for dBV when measuring ac voltage is one volt and when measuring current one milliampere. The reference for dBm in the voltage range is one milliwatt dissipated in 600 Ω or 0.7746 volts; in the current measuring range the reference is 0.7746 milliamperes. When dBm or dBV is applied to current measurements, they have no significance other than to the reference current as stated above.

Useful dB formulas are:

$$\text{dB} = 20 \log_{10} \frac{E_2}{E_1}, 20 \log_{10} \frac{I_2}{I_1} \text{ and } 10 \log_{10} \frac{P_2}{P_1}$$

For calculations substitute the reference voltage or current listed as the denominator.

Temperature Measurements

With the P6430 probe connected to the front panel connector labeled TEMP PROBE, set the range-function switch to the °F or °C in the TEMP position. Apply the probe sensor tip to the device being measured. For optimum temperature transfer, coat the surface of the device being measured with silicone grease and apply the probe tip squarely to the surface. Allow sufficient time for the probe tip to stabilize before taking a reading. The time required depends upon several factors. Generally, when the tip is first applied to the device under test, the readings change rapidly. As the probe tip temperature approaches the temperature of the device under test, the readings change less rapidly, and finally stabilize. The readings are in °C or °F, depending on the position of the range-function switch. See the P6430 manual for more information on temperature measurements and probe use.

Using a Transistor as a Temperature-Sensing Device

Certain npn transistors such as a 2N2484 can be used as separate sensors in place of the P6430 probe with little or no selection of the transistor. Connect the temperature-sensing transistor to the DM 502 through the TEMP PROBE connector as shown in Fig. 1-4. Accuracy without recalibration of the DM 502 is within ±8°C to 150°C. If the

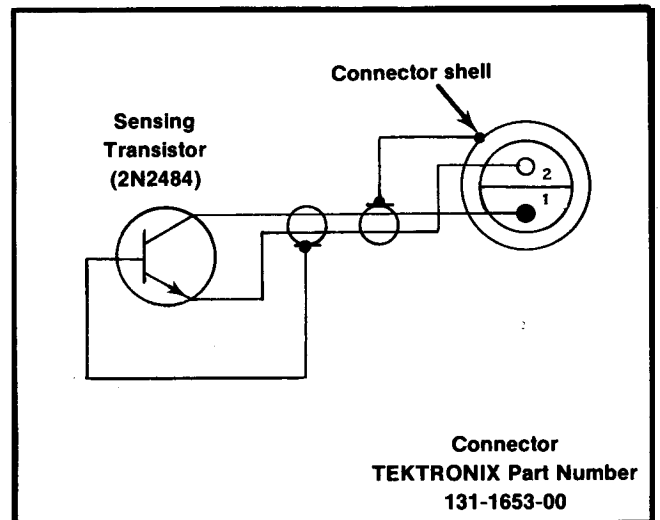

Fig. 1-4. Schematic diagram of temperature-sensing transistor connected to probe connector.

Operating Instructions—DM 502

measurement to be made requires greater accuracy, recalibrate the temperature circuitry or determine a correction factor. Place the sensing device in an environment having a known ambient temperature. Use any difference between the known temperature and the DM 502 readout as a correction factor throughout the entire measurement range.

Accurate Current Source

The OHMS positions on the range-function switch provide accurate (typically 0.2%) constant currents at the INPUT terminals. See the Ohmmeter specifications for the value of the currents and maximum voltages across the INPUT terminals for full scale display readings. The maximum voltage available across the INPUT terminals in the OHMS position is about 10 volts.

ELECTRICAL SPECIFICATIONS

Performance Conditions

The electrical characteristics are valid only if the DM 502 has been calibrated at an ambient temperature between +20°C and +30°C and is operating at an ambient temperature between +15°C and +40°C. Warm up time to specified accuracy is twenty minutes.

Display

The measurement rate is 3.33 per second. Resolution on all ranges is 0.05% of full scale setting; except for temperature, which is 0.1°.

STEP RESPONSE TIME:

≤1/2 s.

INPUT RESISTANCE:

10 MΩ ±0.25% (jumper selectable for > 1000 MΩ on 0.2 V and 2 V ranges).

MAXIMUM INPUT VOLTAGE ON ANY RANGE:

Front Panel: 1 kV.
Rear Connector: 350 V.

DC VOLTMETER

RANGES:

200 mV, 2 V, 20 V, 200 V, 1000 V.

ACCURACY:

±0.1% of reading, ±1 count.

COMMON MODE REJECTION:

≥100 dB at dc, 80 dB at 50 or 60 Hz with a 1 kΩ unbalance.

NORMAL MODE REJECTION:

≥80 dB at 50 or 60 Hz.

AC VOLTMETER

RANGES:

Voltage: 200 mV, 2 V, 20 V, 200 V, 500 V.
dB: -40, -20, 0, 20, 40. Reference is dBV (1 V) or dBm (1 mW dissipated in 600 Ω, 0.7746 V).

ACCURACY:

Voltage: ±0.5% of reading, ±1 count, for a 40 Hz to 10 kHz sine wave.

±1.0% of reading, ±1 count, for a 20 Hz to 20 kHz sine wave.

Usable to 100 kHz. Typically <10% down between 40 mV and 500 V at 100 kHz.

DB:

Display Reading	Frequency Range	Maximum
0 to +20	20 Hz to 20 kHz	0.5 dB
0 to -10	20 Hz to 2 kHz	0.5 dB
	2 kHz to 20 kHz	1.0 dB
-10 to -20	20 Hz to 2 kHz	0.5 dB
	2 kHz to 7.5 kHz	1.0 dB
	7.5 kHz to 20 kHz	2.0 dB

COMMON MODE REJECTION:

≥60 dB at 50 or 60 Hz with a 1 kΩ unbalance.

RESPONSE TIME:

≤ 5 s.

INPUT IMPEDANCE:

10 MΩ ±1% paralleled by ≤ 60 pF.

MAXIMUM INPUT VOLTAGE ON ANY RANGE:

Front Panel: 500 V ac rms or +56 dBm or 600 V dc, not to exceed 1 kV dc plus peak ac.

Rear Connector: 350 V dc plus peak ac or +50 dBm.

OHMMETER

RANGES:

200 Ω, 2 kΩ, 20 kΩ, 200 kΩ, 2 MΩ, 20 MΩ.

ACCURACY:

200 Ω range, 0.5% ±1 count, +0.1 Ω.
 2 kΩ through 2 MΩ ranges, ±0.5%, ±1 count.
 20 MΩ range, 1.0%, ±1 count.

MEASUREMENT CURRENT AND VOLTAGE:

Range	Current	Full Scale Voltage
200 Ω	1 mA	0.2 V
2 kΩ	1 mA	2 V
20 kΩ	100 μA	2 V
200 kΩ	10 μA	2 V
2 MΩ	1 μA	2 V
20 MΩ	0.1 μA	2 V

RESPONSE TIME:

200 Ω through 2 MΩ ranges, ≤1/2 s. 20 MΩ range, ≤5 s.

MAXIMUM INPUT VOLTAGE ON ANY RANGE:

130 V dc and ac rms indefinitely.
 250 V dc and ac rms for one-half hour.

DC AMMETER

RANGES:

200 μA, 2 mA, 20 mA, 200 mA, 2 A.

ACCURACY:

±0.2% of reading, ±1 count.

RESPONSE TIME:

<1/2 s.

INPUT IMPEDANCE:

$$\frac{0.2 \text{ V}}{\text{Range Setting}} + 0.1 \Omega$$

except <2.0 kΩ on the 200 μA range.

MAXIMUM INPUT CURRENT ON ANY RANGE:

Fused at 2.5 A.

AC AMMETER

RANGES:

Current: 200 μA, 2 mA, 20 mA, 200 mA, 2 A.
 dB: -40, -20, 0, 20, 40. Reference is 1 mA (dBV) or 0.7746 mA (dBm).

Operating Instructions—DM 502

ACCURACY:

Current: $\pm 0.6\%$ of reading, ± 1 count for a 40 Hz to 10 kHz sine wave. Usable to 100 kHz.

DB:

Display Reading	Frequency Range	Maximum
0 to +20	20 Hz to 20 kHz	0.5 dB
0 to -10	20 Hz to 2 kHz	0.5 dB
	2 kHz to 20 kHz	1.0 dB
-10 to -20	20 Hz to 2 kHz	0.5 dB
	2 kHz to 7.5 kHz	1.0 dB
	7.5 kHz to 20 kHz	2.0 dB

RESPONSE TIME:

≤ 5 s.

INPUT IMPEDANCE:

$$\frac{0.2 \text{ V}}{\text{Range Setting}} + 0.1 \Omega$$

except $< 2.0 \text{ K}\Omega$ on the $200 \mu\text{A}$ range.

MAXIMUM INPUT CURRENT ON ANY RANGE:

Fused at 2.5 A.

THERMOMETER

RANGES:

Centigrade: -55° to $+150^\circ$.
Fahrenheit: -67° to $+200^\circ$.

ACCURACY:

With any P6430 probe, $\pm 8^\circ\text{C}$ or $\pm 14.4^\circ\text{F}$.
With instrument calibrated to probe, $\pm 2^\circ\text{C}$ or $\pm 3.6^\circ\text{F}$.

MAXIMUM INPUT VOLTAGE:

Up to 1 kV may be safely applied to the front panel INPUT terminals (350 V to the rear input connectors) when the range-function switch is in the TEMP positions.

ENVIRONMENTAL SPECIFICATIONS

TEMPERATURE:

Operating: $+15^\circ\text{C}$ to $+40^\circ\text{C}$.
Non-operating: -40°C to $+75^\circ\text{C}$.

POWER CONSUMPTION:

6.5 watts.

THEORY OF OPERATION

THEORY OF OPERATION

Introduction

The DM 502 is basically an analog-to-digital converter with the logic, display devices, and power supplies necessary to display, in digital form, the value of a dc voltage. The analog-to-digital converter is an integrating amplifier. Current is measured by passing the unknown current through a known resistance and measuring the resultant voltage drop, using a four terminal configuration. Resistance is measured by passing a constant current through an unknown resistance and measuring the voltage drop across the unknown resistance. Temperature is measured by obtaining a dc voltage proportional to the temperature and measuring that voltage. Ac voltages and currents are rectified and the resulting dc is measured, then read out in appropriate ac units. The dB circuitry converts the output of the ac rectifier to a logarithmic output that is applied to the analog-to-digital converter. Refer to the Block Diagram in the foldout pages for an overall view of the DM 502 operation.

Use the following circuit description with the schematics to gain an understanding of the operation of the DM 502.

Attenuator and Input Switching

The HI and LO binding posts are connected across R147, R146 and R145 serving as a voltage divider. The various capacitors switched across these resistors are the compensating capacitors used in the ac modes of operation. C100 is switched in series with the divider when the unit is operating in the ac voltage modes.

R105, R106, R107, R110 and R142 serve as current shunts in the current modes. A four terminal technique is used. The current passes through the shunts from the HI terminal to the LO terminal. The voltage is applied to the analog-to-digital converter through S110, 17, 16, 9, 15 and 18 to ground. F100, in series with shunts R105, R106, R107 and R110 along with CR110 and CR112, protect the shunts from over current. The diodes conduct, opening the fuse before the voltage across the higher value shunts damage them. Lamp RT100 protects shunt R142, in the lowest current range, and the Ohms Converter.

Ac Converter

In the ac measurement modes, the ac signal is applied to fet Q165. CR165 and CR166 protect Q165 from over voltage. Q170, connected from the source to the drain of Q165, provides bootstrapping.

The output of Q165 is fed to the negative input of U195, an operational amplifier. A small amount of negative dc feedback is provided by R192, R190 and the filtering action of C190. The gain of U195 is extremely high until CR187 and CR195 conduct. This high gain allows rectification of extremely small signals. More negative dc feedback is provided through the action of CR187 and CR195. The dc feedback stabilizes the operational amplifier gain and compensates for amplifier offset voltages or capacitor leakage.

The positive half cycle is applied through CR195 to the filter network. The dc voltage from the filter output is switched to the analog-to-digital converter input in the ac measurement mode, and the dB converter in the dB mode. The gain of U195 is set by R180 and R181 to produce a dc output equivalent to the rms value of a sine-wave input.

DB Converter

This circuitry converts the linear dc current output from the ac converter to a logarithmic output voltage. A collector current change with respect to a base to emitter voltage change in a bipolar transistor is logarithmic.

VR310 serves as the voltage reference diode at 6.2 V. This voltage is applied to the negative input of operational amplifier U210 through R203 and R205. R205 sets the current through Q120A. Should the current through Q120A increase, the voltage at pin 2 of U210 goes negative. This causes the output of U210 to go positive reducing the current through the transistor to the value set by R205. Q120A and Q120B are housed in the same case so that their base to emitter voltages remain constant with temperature (for equal collector currents).

Theory of Operation—DM 502

The rectified and filtered dc current from the ac converter is applied to the plus input of operational amplifier U220, through R212. R212 causes a reference current shift in the dBm mode and is shorted out in the dBV mode. As pin 3 of U220 goes positive, the output goes positive. The base of Q120B goes positive and the collector negative providing negative feedback. The collector current of Q120A always equals the current through R212 at 0 dB. The necessary voltage at the output of U220 is logarithmic due to the logarithmic characteristics of Q120B in the feedback loop. As the temperature increases the gain of Q120B decreases. This is compensated for by RT220 decreasing in value with increasing temperature.

Ohms Converter

U135 is an operational amplifier. The current setting resistances are connected from the output to the plus input terminal of U135. The unknown resistances are connected from the plus terminal to floating ground. See Fig. 2-1. Negative feedback occurs from the output of U135 to the negative input terminal. R130 is the calibration adjustment. R135 and R136 are switched in and out of the negative feedback loop to provide bias current compensation.

The value of the current setting resistance is always equal to one half of the full scale measurement value, except on the 200 Ω range, as shown on the range-

function switch. The 200 Ω scale uses 1 k Ω and the gain of the analog-to-digital converter is increased by a factor of ten. R130 adjusts the gain of the amplifier to produce one volt across the current setting resistance (0.1 V in the 200 Ω range). As long as the unknown resistance is within the measurement range, the circuitry adjusts the current so that the drop across the current setting resistance is one volt. This current flows through the unknown resistance, varying the voltage at the plus terminal of U135. This voltage is then fed to the analog-to-digital converter input.

Temperature Measurement Circuitry

This circuitry operates on the principle that a change in base to emitter voltage of a bipolar transistor is proportional to the temperature of the junction as the collector current is changed between two levels.

A square wave (about 2 kHz) is generated by Q230 and Q235 operating as an astable multivibrator. The square wave is applied to the gates of Q255 and Q260.

The collector to base voltage of the temperature sensing transistor in the probe is held constant. When fet Q255 is off, the current to the probe through R255 and R257 is approximately one-tenth the on current.

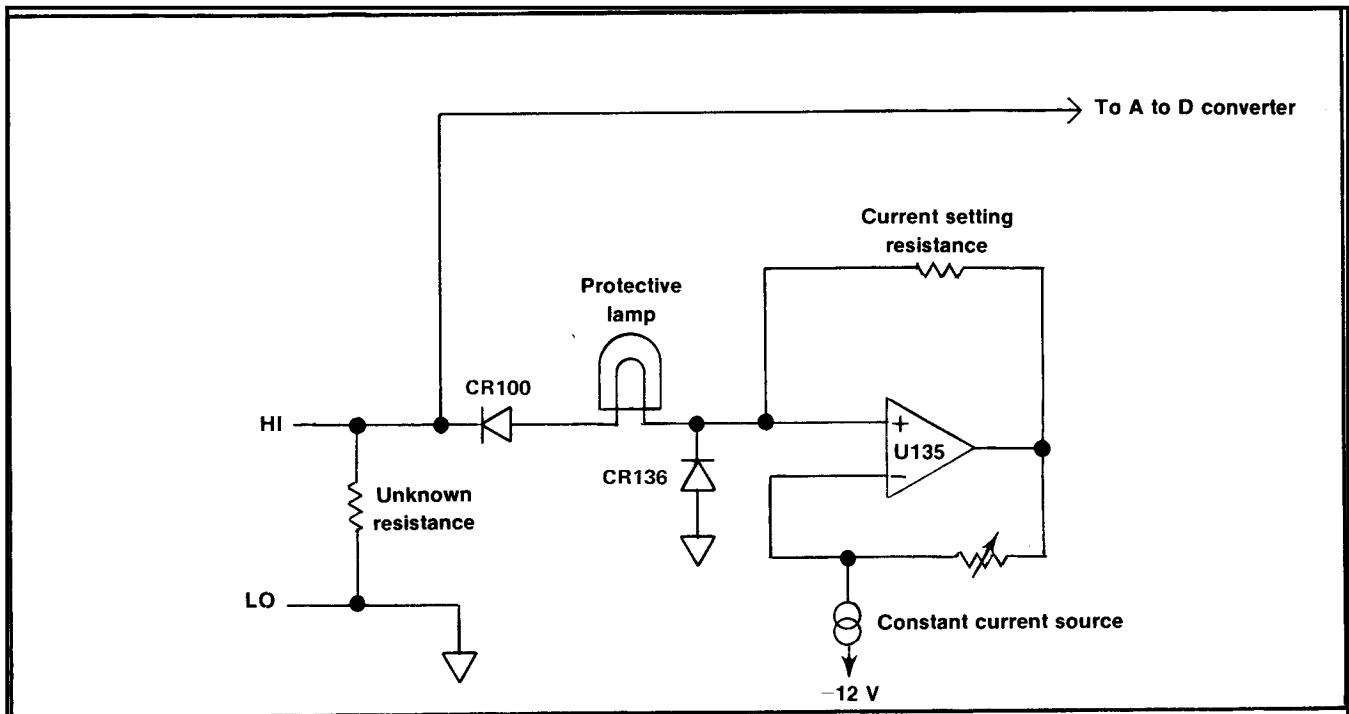

Fig. 2-1. Simplified diagram of Ohms Converter.

When Q230 is off and Q235 is on, Q255 is off and the voltage at pin 2 of U250A goes negative. The output of U250A goes positive, reducing the temperature-variable base-emitter current of the sensing transistor until pin 2 of U250A is at ground. A positive-going square wave results at the output of U250A, with an amplitude proportional to the temperature of the base-emitter junction. Q260 is on and Q245 is off, due to the action of Q230 and Q235. A dc voltage, whose amplitude is proportional to temperature, occurs across C263. The opposite occurs when Q230 and Q235 change state, with the exception that Q245 turns on, shorting the negative voltage to ground; and Q260 is off, preventing the discharge of C263. The dc voltage across C263 is applied to operational amplifier U250B. R280 adjusts the gain. Offset voltage in U250B is compensated for by R270. R268 and R285, through S110, 44, change offset and increase gain for °F readout vs °C. The output of U250B at 10 mV/° is applied to the analog-to-digital converter input and the rear interface connectors.

Clock

U325 is a monolithic timing circuit used to generate the clock frequency for the DM 502. The frequency is 20.48 kHz. C330, the timing capacitor, charges through R328, R329 and R330, and discharges through R330. R328 sets the frequency so that it is a multiple of the power line frequencies. This insures minimization of line frequency interference in the analog-to-digital converter.

Analog-To-Digital Converter

U290 comprises the analog-to-digital converter and U335 contains the necessary control logic. U290 contains the integrating amplifier, comparator, auto-zero amplifier and input buffer amplifier. See Fig. 2-2. C300 is the integrating capacitor. The clock frequency is divided by the time base counter into groups of 6144 pulses. Measurement takes place for 4096 of these pulses and automatic zeroing takes place for 2048 pulses. The auto-zeroing feature provides current to compensate for offset currents in the buffer amplifier.

Basic sensitivity of the analog-to-digital converter is 2 V for a full scale display reading. When S110, 36 is closed, the sensitivity becomes 0.2 V full scale.

During auto zero, the input of the buffer amplifier is grounded. The buffer offset current also offsets the output of the integrator. The offset at the integrator output passes through a low-pass filter comprised of C300, R300 and R302 to the plus input of the auto-zero amplifier. The output of the unity gain auto-zero amplifier compensates for this offset current at the summing node (pin 9) at the integrator input. The reference current through R304 and R305 from the reference current source, is applied for four clock cycles and disconnected for the next four cycles by the U/D control logic. The reference current is connected to R304 when the up-down logic is low. Equilibrium for the

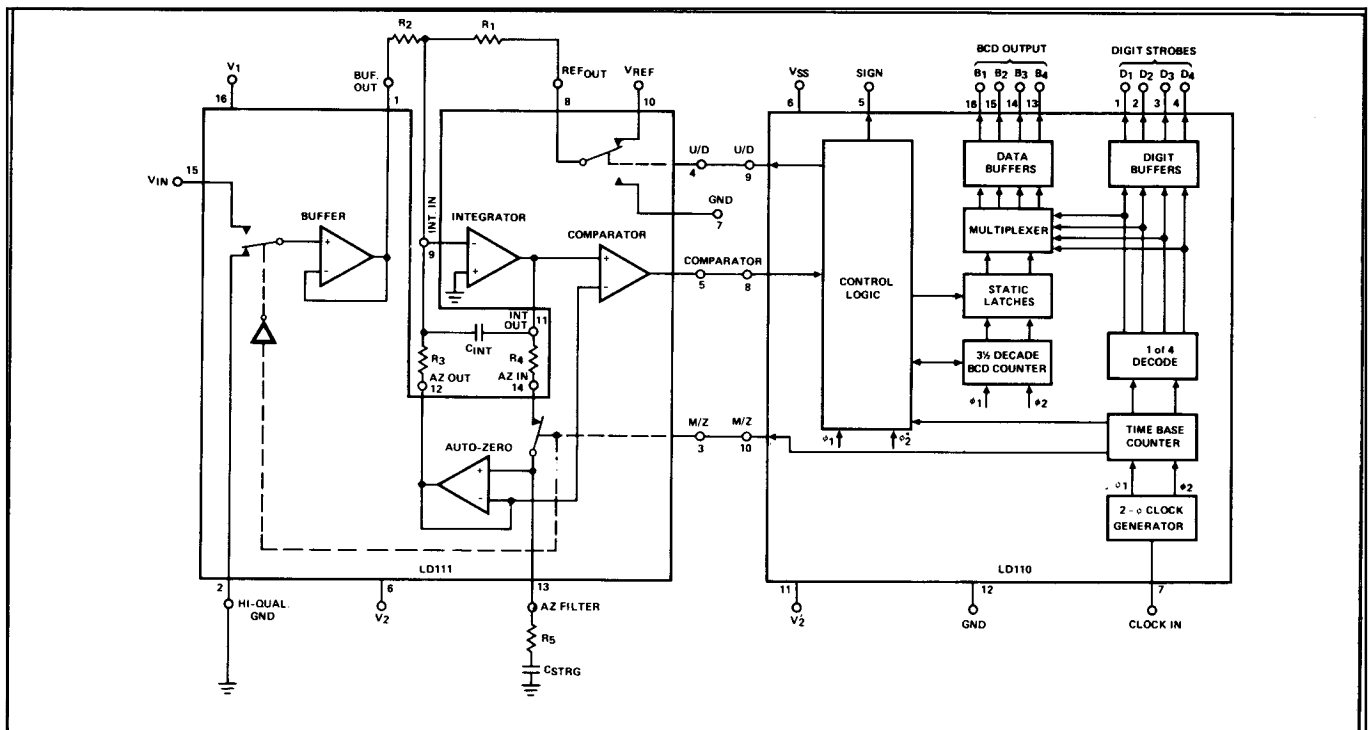

Fig. 2-2. Analog to digital converter and control logic block diagram. Reprinted by permission of Siliconix Inc.

Theory of Operation—DM 502

entire integrating and auto-zero system is obtained when the sum of the average currents at the integrator summing junction equals zero. C316 charges to the equilibrium voltage and maintains this voltage at the auto-zero amplifier input during the measurement interval when the switch from the integrator output is open. See Fig. 2-3 for functional timing during the auto-zero interval. Notice that the fifty percent duty cycle of the up-down counter is overridden at the start of the auto-zero interval. This override period permits the output of the integrator to come to V_{strg} and C316 to assume this voltage.

Upon completion of the 2048 clock pulse auto-zero interval, the measurement interval commences. The measure-zero logic switches the analog input voltage to the buffer input and disconnects the integrator output from the auto-zero amplifier input. The additional current resulting at the summing junction of the integrator causes the integrator output voltage to move away from the equilibrium voltage obtained during auto-zero interval and maintained during the measurement interval by C316. The comparator senses and transmits this deviation to the control logic. The control logic changes the duty cycle of the reference voltage in an attempt to re-establish equilibrium at the integrator summing junction. The up-down logic is up (integrator output voltage is also up) for one clock cycle and down for seven cycles when the comparator output was high during the preceding set of eight clock cycles. This is shown as duty cycle A in Fig. 2-4. When the comparator output is low in clock cycle seven, the up-down logic is up for seven cycles and down for one cycle during the following eight clock cycles. This is shown as duty cycle B. Fig. 2-4 shows the result of these actions on the integrator output.

A counter, synchronous with the up-down logic, increments by each clock pulse when the up-down logic is up and decrements by each clock pulse when the up-down logic is down. The net count increases by six counts for each B duty cycle and decreases by six counts for each A duty cycle, to a maximum count of about 3100. This counting procedure is reversed for negative input voltages.

Polarity of the input voltage is determined by the state of the up-down logic when the bcd counter state is zero. This information is stored in a flip-flop and loaded into the static latch once each measure-zero cycle.

The bcd counter accumulates a number of counts proportional to the input voltage during the measure interval while the control logic works to maintain equilibrium. It can be seen that equilibrium is achieved in steps and usually a residual voltage remains at the end of the measurement cycle. This residual voltage is compensated for by a short override interval at the beginning of the auto-zero period. The counter continues until the integrator output equals the auto-zero equilibrium voltage and the up-down logic is down. The bcd counter is now put on hold and its contents loaded into the latches. The counter is then cleared.

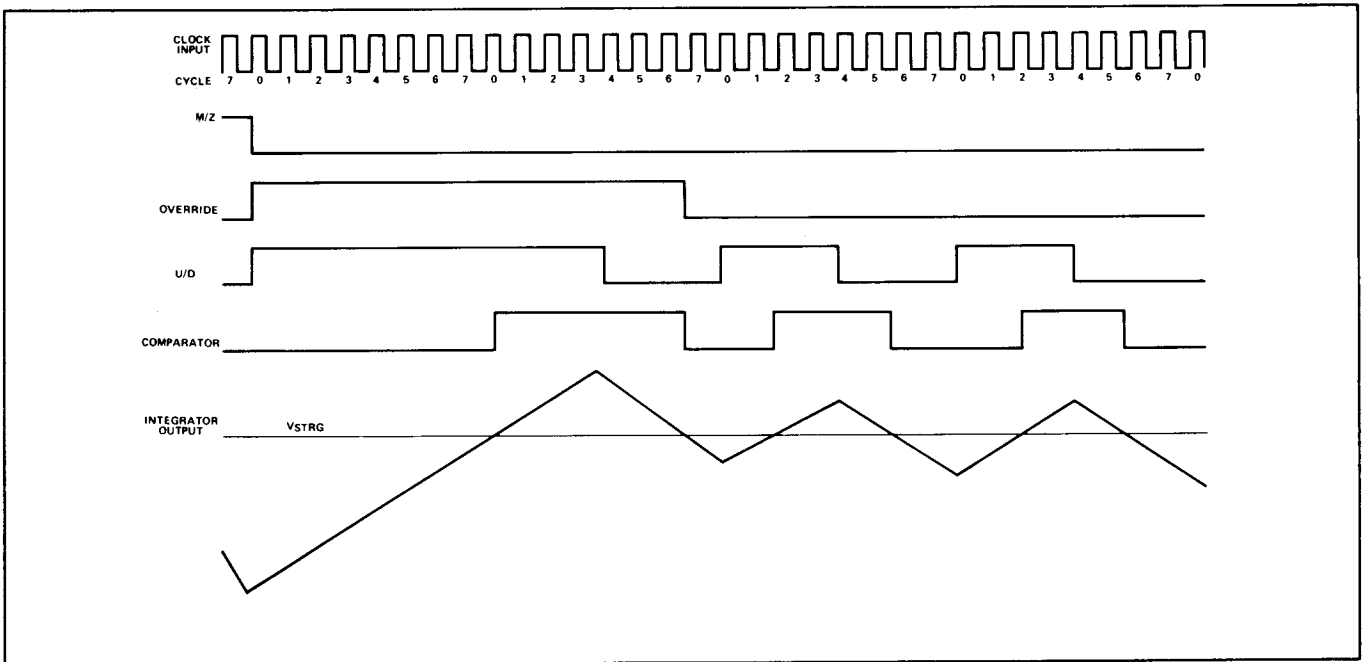

Fig. 2-3. Auto-zero timing intervals. Reprinted by permission of Siliconix Inc.

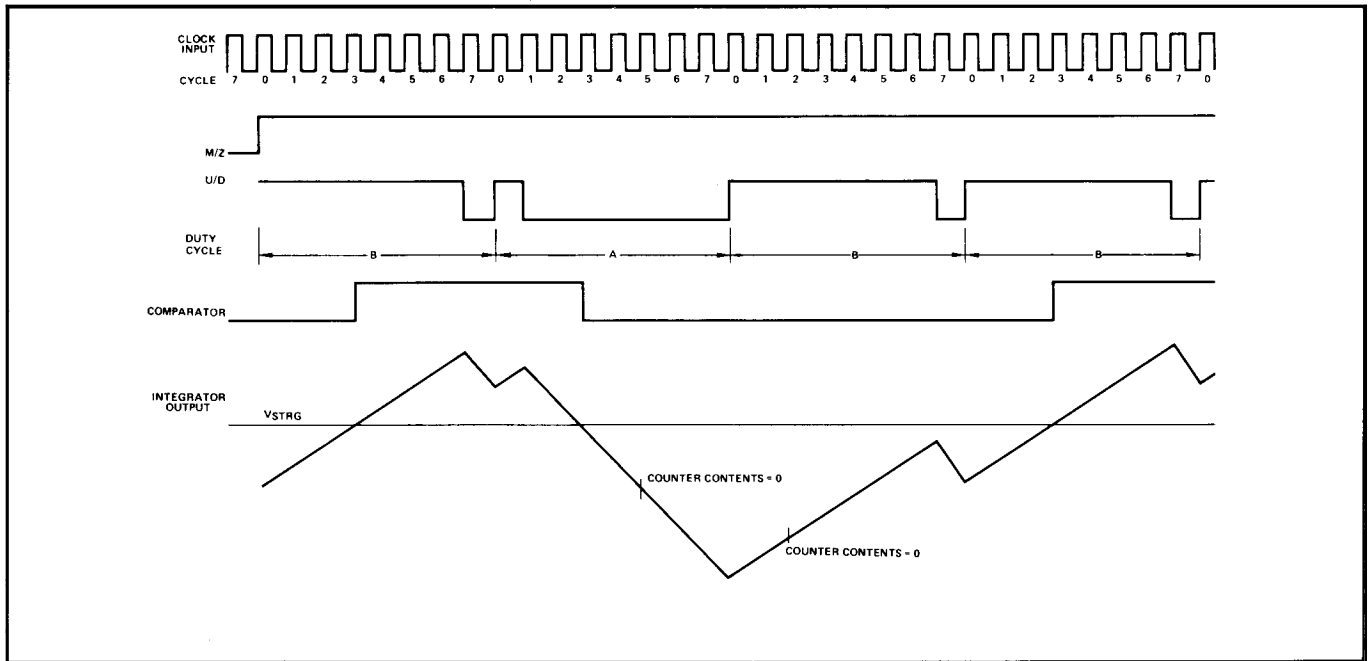

Fig. 2-4. Measurement interval timing. Reprinted by permission of Siliconix, Inc.

Display

The bcd data from the data buffers is applied to U340, a bcd to seven segment decoder. All segments of digits one, two and three are connected in parallel to U340. The high outputs from the digit buffers are inverted by U345A, B, C and D, which drive Q350 for digit one, Q355 for digit two, Q360 for digit three and Q365 for the most significant digit. When the collectors of these transistors are high, the particular digit is displayed. This is accomplished in a one, three, two, four sequence. The common terminal for the polarity signs is also activated by Q365 at the most significant digit time. S110, 37, 38 and S200 disconnect the polarity signs when not appropriate for the measurement mode in use. S200 is on the dB switch. When pin 5 of U335 is high the positive sign is lighted. When pin 5 of U335 is low, the negative sign is illuminated by the action of Q375 and U345F.

The decimal positions are changed by contacts in the range-function and dB switches through Q370. As pin 16 of U335 is the bcd one line to the seven segment decoder, when the most significant digit is present, pin 16 is high. This is converted to a low and connected to the cathodes of the ones segments in the most significant digit module.

The contents of the static latches are multiplexed to the data output buffers. The data output format is an interlaced scan of digits one, three, two and four. Four is the most significant digit. With a count of 2000 or greater in the counter (100% of full scale) the 3-1/2 digit display blinks off during the zero cycle.

Power Supplies

The entire DM 502 circuitry, with the exception of the temperature circuitry can be elevated up to 1kV above chassis ground. Isolation is accomplished with transformer T410. 50 V ac from the power module (two 25 V ac windings in series) is applied to the transformer primary. Ac for the +5 V and ± 12 V supplies is bridge rectified. U420, for the ± 12 V supplies, is a dual tracking voltage regulator. R418 is a current shunt for the +12 V supply and R427 is the same for the -12 V supply. R422 sets the levels. U420 is internally protected against short circuit damage. Power for the display modules is not electronically smoothed, regulated or filtered.

Q440 serves as the series pass transistor for the +5 V supply. The output voltage is set through the divider consisting of R452 and R453 connected to the base of Q450. Should the +5 V output drop, Q450 increases conduction. This causes Q440 to also increase conduction restoring the output voltage to the preset level.

The temperature measuring circuitry obtains ± 15 V from ± 33.5 V through zener diodes VR400 and VR405.

REPLACEABLE ELECTRICAL PARTS

PARTS ORDERING INFORMATION

Replacement parts are available from or through your local Tektronix, Inc. Field Office or representative.

Changes to Tektronix instruments are sometimes made to accommodate improved components as they become available, and to give you the benefit of the latest circuit improvements developed in our engineering department. It is therefore important, when ordering parts, to include the following information in your order: Part number, instrument type or number, serial number, and modification number if applicable.

If a part you have ordered has been replaced with a new or improved part, your local Tektronix, Inc. Field Office or representative will contact you concerning any change in part number.

Change information, if any, is located at the rear of this manual.

SPECIAL NOTES AND SYMBOLS

X000 Part first added at this serial number
00X Part removed after this serial number

ITEM NAME

In the Parts List, an Item Name is separated from the description by a colon (:). Because of space limitations, an Item Name may sometimes appear as incomplete. For further Item Name identification, the U.S. Federal Cataloging Handbook H6-1 can be utilized where possible.

ABBREVIATIONS

ACTR	ACTUATOR	PLSTC	PLASTIC
ASSY	ASSEMBLY	QTZ	QUARTZ
CAP	CAPACITOR	RECP	RECEPTACLE
CER	CERAMIC	RES	RESISTOR
CKT	CIRCUIT	RF	RADIO FREQUENCY
COMP	COMPOSITION	SEL	SELECTED
CONN	CONNECTOR	SEMICOND	SEMICONDUCTOR
ELCTLT	ELECTROLYTIC	SENS	SENSITIVE
ELEC	ELECTRICAL	VAR	VARIABLE
INCAND	INCANDESCENT	WW	WIREWOUND
LED	LIGHT EMITTING DIODE	XFMR	TRANSFORMER
NONWIR	NON WIREWOUND	XTAL	CRYSTAL

CROSS INDEX MFR. CODE NUMBER TO MANUFACTURER

MFR.CODE	MANUFACTURER	ADDRESS	CITY,STATE,ZIP
00853	SANGAMO ELECTRIC CO., S. CAROLINA DIV.	P. O. BOX 128	PICKENS, SC 29671
01121	ALLEN-BRADLEY CO.	1201 2ND ST. SOUTH	MILWAUKEE, WI 53204
01295	TEXAS INSTRUMENTS, INC., SEMICONDUCTOR GROUP	P. O. BOX 5012	DALLAS, TX 75222
03508	GENERAL ELECTRIC CO., SEMI-CONDUCTOR PRODUCTS DEPT.	ELECTRONICS PARK 60 S. JEFFERSON RD.	SYRACUSE, NY 13201 WHIPPANY, NJ 07981
03888	KDI PYROFILM CORP.		
04713	MOTOROLA, INC., SEMICONDUCTOR PRODUCTS DIV.	5005 E. MCDOWELL RD.	PHOENIX, AZ 85036
07263	FAIRCHILD SEMICONDUCTOR, A DIV. OF FAIRCHILD CAMERA AND INSTRUMENT CORP.	464 ELLIS ST.	MOUNTAIN VIEW, CA 94042
07910	TELEDYNE SEMICONDUCTOR	12515 CHADRON AVE.	HAWTHORNE, CA 90250
14752	ELECTRO CUBE INC.	1710 S. DEL MAR AVE.	SAN GABRIEL, CA 91776
15281	GENERAL INSTRUMENT CORP., DELETED, BUSINESS DISCONTINUED		
15454	RODAN INDUSTRIES, INC.	2905 BLUE STAR ST.	ANAHEIM, CA 92806
15818	TELEDYNE SEMICONDUCTOR	1300 TERRA BELLA AVE.	MOUNTAIN VIEW, CA 94040
17856	SILICONIX, INC.	2201 LAURELWOOD RD.	SANTA CLARA, CA 95054
18324	SIGNETICS CORP.	811 E. ARQUES	SUNNYVALE, CA 94086
19396	ILLINOIS TOOL WORKS, INC., PAKTRON DIV.	1321 LESLIE AVE.	ALEXANDRIA, VA 22301
27014	NATIONAL SEMICONDUCTOR CORP.	2900 SAN YSIDRO WAY	SANTA CLARA, CA 95051
28480	HEWLETT-PACKARD CO., CORPORATE HQ.	1501 PAGE MILL RD.	PALO ALTO, CA 94304
34553	AMPEREX ELECTRONIC CORP., COMPONENT DIV.	35 HOFFMAN AVE.	HAPPAUGE, NY 11787
49956	RAYTHEON CO.	141 SPRING ST.	LEXINGTON, MA 02173
50522	MONSANTO CO., ELECTRONIC SPECIAL PRODUCTS	10131 BUBB RD.	CUPERTINO, CA 95014
56289	SPRAGUE ELECTRIC CO.		NORTH ADAMS, MA 01247
58474	SUPERIOR ELECTRIC CO., THE	383 MIDDLE ST.	BRISTOL, CT 06010
71400	BUSSMAN MFG., DIVISION OF MCGRAW- EDISON CO.	2536 W. UNIVERSITY ST.	ST. LOUIS, MO 63107
71590	CENTRALAB ELECTRONICS, DIV. OF GLOBE-UNION, INC.	5757 N. GREEN BAY AVE.	MILWAUKEE, WI 53201
71744	CHICAGO MINIATURE LAMP WORKS	4433 RAVENSWOOD AVE.	CHICAGO, IL 60640
72982	ERIE TECHNOLOGICAL PRODUCTS, INC.	644 W. 12TH ST.	ERIE, PA 16512
73138	BECKMAN INSTRUMENTS, INC., HELIPOT DIV.	2500 HARBOR BLVD.	FULLERTON, CA 92634
75042	TRW ELECTRONIC COMPONENTS, IRC FIXED RESISTORS, PHILADELPHIA DIVISION	401 N. BROAD ST.	PHILADELPHIA, PA 19108
80009	TEKTRONIX, INC.	P. O. BOX 500	BEAVERTON, OR 97077
80031	ELECTRA-MIDLAND CORP., MEPCO DIV., A NORTH AMERICAN PHILLIPS CO.	22 COLUMBIA RD.	MORRISTOWN, NJ 07960
80294	BOURNS, INC., INSTRUMENT DIV.	6135 MAGNOLIA AVE.	RIVERSIDE, CA 92506
81483	INTERNATIONAL RECTIFIER CORP.	9220 SUNSET BLVD.	LOS ANGELES, CA 90069
86684	RCA CORP., ELECTRONIC COMPONENTS	415 S. 5TH ST.	HARRISON, NJ 07029
90201	MALLORY CAPACITOR CO., DIV. OF P. R. MALLORY CO., INC.	3029 E. WASHINGTON ST.	INDIANAPOLIS, IN 46206
91637	DALE ELECTRONICS, INC.	P. O. BOX 609	COLUMBUS, NB 68601

Ckt No.	Tektronix Part No.	Serial/Model No.		Name & Description	Mfr	
		Eff	Dscont		Code	Mfr Part Number
A1	670-3495-00	B010100	B019999	CKT BOARD ASSY:MAIN	80009	670-3495-00
A1	670-3495-01	B020000		CKT BOARD ASSY:MAIN	80009	670-3495-01
A1	670-3694-00	B010100	B019999	CKT BOARD ASSY:MAIN OPTION 2	80009	670-3694-00
A1	670-3694-01	B020000		CKT BOARD ASSY:MAIN OPTION 2	80009	670-3694-01
A2	670-3509-00			CKT BOARD ASSY:DISPLAY	80009	670-3509-00
C100	285-1106-00			CAP.,FXD,PLSTC:0.22UF,20%,600V	14752	230B1F223
C110	283-0279-00	XB020000		CAP.,FXD,CER DI:0.001UF,20%,3000V	72982	878Y5S102M
C120	290-0536-00			CAP.,FXD,ELCTLT:10UF,20%,25V	90201	TDC106M025NLF
C130	283-0003-00			CAP.,FXD,CER DI:0.01UF,+80-20%,150V	72982	855-547E103Z
C142	283-0626-00			CAP.,FXD,MICA D:1800PF,5%,500V	00853	D195E182J0
C146	283-0626-00			CAP.,FXD,MICA D:1800PF,5%,500V	00853	D195E182J0
C150	281-0182-00			CAP.,VAR,PLSTC:1.8-10PF,300V	34553	2222-809-05002
C151	281-0515-00			CAP.,FXD,CER DI:27PF,+/-1.35PF,500V	72982	302-000COG0270J
C152	281-0564-00			CAP.,FXD,CER DI:24PF,5%,500V	72982	301-000COG0240J
C154	281-0579-00			CAP.,FXD,CER DI:21PF,5%,500V	72982	301-050COG0210J
C155	281-0184-00			CAP.,VAR,PLSTC:2-18PF,500VDC	34553	2222-809-05003
C157	285-0596-00			CAP.,FXD,PLSTC:0.01UF,1%,100V	56289	490P10311
C158	285-0719-00			CAP.,FXD,PLSTC:0.015UF,5%,100V	56289	410P113
C168	283-0003-00			CAP.,FXD,CER DI:0.01UF,+80-20%,150V	72982	855-547E103Z
C170	283-0003-00			CAP.,FXD,CER DI:0.01UF,+80-20%,150V	72982	855-547E103Z
C175	290-0535-00			CAP.,FXD,ELCTLT:33UF,20%,10V	56289	196D336X0010KA1
C190	290-0527-00			CAP.,FXD,ELCTLT:15UF,20%,20V	90201	TDC156M020NLF
C192	281-0661-00			CAP.,FXD,CER DI:0.8PF,+/-0.1PF,500V	72982	301-000COG0808B
C195	290-0723-00			CAP.,FXD,ELCTLT:150UF,20%,6VDC,DIPPED TANT	56289	196D157X0006PE3
C197	290-0525-00	B010100	B019999	CAP.,FXD,ELCTLT:4.7UF,20%,50V	56289	196D475X0050KA1
C197	290-0536-00	B020000		CAP.,FXD,ELCTLT:10UF,20%,25V	90201	TDC106M025NLF
C198	290-0536-00	B010100	B019999	CAP.,FXD,ELCTLT:10UF,20%,25V	90201	TDC106M025NLF
C198	290-0527-00	B020000		CAP.,FXD,ELCTLT:15UF,20%,20V	90201	TDC156M020NLF
C199	290-0512-00	B010100	B019999	CAP.,FXD,ELCTLT:22UF,20%,15V	56289	196D226X0015KA1
C199	290-0535-00	B020000		CAP.,FXD,ELCTLT:33UF,20%,10V	56289	196D336X0010KA1
C208	281-0513-00			CAP.,FXD,CER DI:27PF,+/-5.4PF,500V	72982	301-000P2G0270M
C220	283-0065-00			CAP.,FXD,CER DI:0.001UF,5%,100V	72982	805-505B102J
C230 ¹	283-0065-00			CAP.,FXD,CER DI:0.001UF,5%,100V	72982	805-505B102J
C235 ¹	283-0065-00			CAP.,FXD,CER DI:0.001UF,5%,100V	72982	805-505B102J
C251 ¹	281-0546-00			CAP.,FXD,CER DI:330PF,10%,500V	72982	301-000X5P0331K
C253	283-0114-00			CAP.,FXD,CER DI:0.0015UF,5%,200V	72982	805-509B152J
C254	283-0114-00			CAP.,FXD,CER DI:0.0015UF,5%,200V	72982	805-509B152J
C257 ¹	283-0065-00			CAP.,FXD,CER DI:0.001UF,5%,100V	72982	805-505B102J
C260 ¹	285-0808-00			CAP.,FXD,PLSTC:0.1UF,10%,50V	56289	LP66A1A104K004
C263	290-0536-00			CAP.,FXD,ELCTLT:10UF,20%,25V	90201	TDC106M025NLF
C265 ¹	283-0065-00			CAP.,FXD,CER DI:0.001UF,5%,100V	72982	805-505B102J
C270 ¹	290-0525-00			CAP.,FXD,ELCTLT:4.7UF,20%,50V	56289	196D475X0050KA1
C285 ¹	283-0001-00			CAP.,FXD,CER DI:0.005UF,+100-0%,500V	72982	831-559E502P
C287 ¹	283-0065-00			CAP.,FXD,CER DI:0.001UF,5%,100V	72982	805-505B102J
C291	285-1101-00			CAP.,FXD,PLSTC:0.022 UF,10%,200V	19396	PT485-022-200-10
C300	285-1101-00			CAP.,FXD,PLSTC:0.022 UF,10%,200V	19396	PT485-022-200-10
C310	290-0536-00			CAP.,FXD,ELCTLT:10UF,20%,25V	90201	TDC106M025NLF
C312	290-0525-00			CAP.,FXD,ELCTLT:4.7UF,20%,50V	56289	196D475X0050KA1
C315	281-0205-00			CAP.,VAR,PLSTC:5.5-65PF,100V	80031	C010GA/60E
C316	285-1102-00			CAP.,FXD,PLSTC:0.1UF,20%,100VDC,REEL PKG	19396	PT720B104M
C320	290-0536-00			CAP.,FXD,ELCTLT:10UF,20%,25V	90201	TDC106M025NLF
C325	290-0512-00			CAP.,FXD,ELCTLT:22UF,20%,15V	56289	196D226X0015KA1
C330	283-0626-00			CAP.,FXD,MICA D:1800PF,5%,500V	00853	D195E182J0

¹Remove for Option 2.

Electrical Parts List—DM 502

Ckt No.	Tektronix Part No.	Serial/Model No. Eff	Dscont	Name & Description	Mfr Code	Mfr Part Number
C400 ¹	290-0525-00			CAP., FXD, ELCTLT: 4.7UF, 20%, 50V	56289	196D475X0050KA1
C405 ¹	290-0525-00			CAP., FXD, ELCTLT: 4.7UF, 20%, 50V	56289	196D475X0050KA1
C410	290-0725-00			CAP., FXD, ELCTLT: 100UF, +75-10%, 50VDC, AL	90201	TT101V050C1J3P
C412	290-0725-00			CAP., FXD, ELCTLT: 100UF, +75-10%, 50VDC, AL	90201	TT101V050C1J3P
C420	290-0525-00			CAP., FXD, ELCTLT: 4.7UF, 20%, 50V	56289	196D475X0050KA1
C425	290-0525-00			CAP., FXD, ELCTLT: 4.7UF, 20%, 50V	56289	196D475X0050KA1
C429	283-0279-00	XB010280	B019999X	CAP., FXD, CER DI: 0.001UF, 20%, 3000V	72982	878Y5S102M
C437	290-0727-00			CAP., FXD, ELCTLT: 300UFD, +75-10%, 25VDC, AL	90201	TT301V025D1J3P
C440	290-0573-00			CAP., FXD, ELCTLT: 2.7UF, 20%, 50V	56289	196D275X0050JA1
C442	290-0525-00			CAP., FXD, ELCTLT: 4.7UF, 20%, 50V	56289	196D475X0050KA1
C444	283-0080-00			CAP., FXD, CER DI: 0.022UF, +80-20%, 25V	56289	19C611
CR100	152-0107-00			SEMICONV DEVICE: SILICON, 375V, 400MA	80009	152-0107-00
CR110	152-0585-00			SEMICONV DEVICE: SILICON, BRIDGE, 75V, 75MA	15281	W02M
CR136	152-0246-00			SEMICONV DEVICE: SILICON, 400PIV, 200MA	07910	CD12676
CR165	152-0246-00			SEMICONV DEVICE: SILICON, 400PIV, 200MA	07910	CD12676
CR166	152-0246-00			SEMICONV DEVICE: SILICON, 400PIV, 200MA	07910	CD12676
CR187	152-0322-00			SEMICONV DEVICE: SILICON, 15V	28480	5082-2672
CR195	152-0322-00			SEMICONV DEVICE: SILICON, 15V	28480	5082-2672
CR230 ¹	152-0141-02			SEMICONV DEVICE: SILICON, 30V, 150MA	07910	1N4152
CR235 ¹	152-0141-02			SEMICONV DEVICE: SILICON, 30V, 150MA	07910	1N4152
CR237 ¹	152-0141-02			SEMICONV DEVICE: SILICON, 30V, 150MA	07910	1N4152
CR240 ¹	152-0141-02			SEMICONV DEVICE: SILICON, 30V, 150MA	07910	1N4152
CR334	152-0141-02			SEMICONV DEVICE: SILICON, 30V, 150MA	07910	1N4152
CR410	152-0585-00			SEMICONV DEVICE: SILICON, BRIDGE, 75V, 75MA	15281	W02M
CR430	152-0585-00			SEMICONV DEVICE: SILICON, BRIDGE, 75V, 75MA	15281	W02M
CR435	152-0107-00			SEMICONV DEVICE: SILICON, 375V, 400MA	80009	152-0107-00
DS350	150-1022-00			LAMP, LED: RED	50522	MAN72
DS355	150-1022-00			LAMP, LED: RED	50522	MAN72
DS360	150-1022-00			LAMP, LED: RED	50522	MAN72
DS365	150-1021-00			LAMP, LED: RED	50522	MAN73
F100	159-0126-00			FUSE, CARTRIDGE: 2.5A, 250 VAC, FAST-BLOW	71400	AGC2-1/2
J100	129-0064-01			POST, BDG, ELEC: RED, 5-WAY MINIATURE	58474	BB10167G2BX
J110	129-0064-00			POST, BDG, ELEC: CHARCOAL, 5-WAY MINIATURE	58474	BINP BB10167G13T
J115	129-0064-02			POST, BDG, ELEC: WHITE, 5-WAY, MINIATURE	58474	DF21WTC
J250 ¹	131-1652-00			CONN, RCPT, ELEC: 1 FEM, 1 MALE CONTACT	0000A	RA0302
Q165	151-1005-00			TRANSISTOR: SILICON, JFE, N-CHANNEL	15818	U1490
Q170	151-0188-00			TRANSISTOR: SILICON, PNP	04713	2N3906
Q230 ¹	151-0341-00			TRANSISTOR: SILICON, NPN	07263	2N3565
Q235 ¹	151-0341-00			TRANSISTOR: SILICON, NPN	07263	2N3565
Q245 ¹	151-1005-00			TRANSISTOR: SILICON, JFE, N-CHANNEL	15818	U1490
Q255 ¹	151-1005-00			TRANSISTOR: SILICON, JFE, N-CHANNEL	15818	U1490
Q260 ¹	151-1005-00			TRANSISTOR: SILICON, JFE, N-CHANNEL	15818	U1490
Q350	151-0301-00			TRANSISTOR: SILICON, PNP	04713	2N2907A
Q355	151-0301-00			TRANSISTOR: SILICON, PNP	04713	2N2907A
Q360	151-0301-00			TRANSISTOR: SILICON, PNP	04713	2N2907A
Q365	151-0301-00			TRANSISTOR: SILICON, PNP	04713	2N2907A
Q370	151-0302-00			TRANSISTOR: SILICON, NPN	04713	2N2222A
Q375	151-0341-00			TRANSISTOR: SILICON, NPN	07263	2N3565
Q380	151-0281-00			TRANSISTOR: SILICON, NPN	03508	X16P4039
Q440	151-0134-00			TRANSISTOR: SILICON, PNP	04713	2N2905A
Q450	151-0341-00			TRANSISTOR: SILICON, NPN	07263	2N3565

¹ Remove for Option 2.

Ckt No.	Tektronix Part No.	Serial/Model No. Eff	Dscont	Name & Description	Mfr Code	Mfr Part Number
R95	315-0102-00			RES.,FXD,CMPSN:1K OHM,5%,0.25W	01121	CB1025
R100	315-0101-03			RES.,FXD,CMPSN:100 OHM,5%,0.25W	01121	CB1015
R105	321-0895-07			RES.,FXD,FILM:90 OHM,0.1%,0.125W	91637	MFF1816C90R00B
R106	308-0772-00			RES.,FXD,WW:9 OHM,0.1%,3W	73138	91A20R00M
R107	308-0770-00			RES.,FXD,WW:1 OHM,0.1%,3 W AXIAL LD	91637	RLS286-B1R000B
R110	308-0769-00			RES.,FXD,WW:0.1 OHM,0.1%,3W 4 TERM	91637	RLS286-BR1000B
R120	321-0184-00			RES.,FXD,FILM:806 OHM,1%,0.125W	75042	CEATO-8060F
R124	321-0365-00			RES.,FXD,FILM:61.9K OHM,1%,0.125W	75042	CEATO-6192F
R128	321-0285-00			RES.,FXD,FILM:9.09K OHM,1%,0.125W	75042	CEATO-9091F
R130	311-1749-00			RES.,VAR,NONWIR:TRMR,1.5K OHM,0.75W	73138	91AR1500M
R135	307-0465-00			RES.,FXD,FILM:10M OHM,1%,0.5W	03888	FL1/2-105F
R136	321-1485-00			RES.,FXD,FILM:1.11M OHM,1%,0.125W	75042	CEATO-1114F
R140	321-0481-04			RES.,FXD,FILM:1M OHM,0.1%,0.125W	91637	MFF1816D10003B
R142	308-0541-00			RES.FXD,WW:1K OHM,0.1%,3W AXIAL LD	91637	RS2B-B10000B
R145	325-0186-00			RES.,SET,MTCH:9.9M OHM,90K OHM,10K OHM	80009	325-0186-00
R146						
R147						
R155	311-1564-00			RES.,VAR,NONWIR:500 OHM,20%,0.50W	73138	91A-500ROM
R157	321-0292-03			RES.,FXD,FILM:10.7K OHM,0.25%,0.125W	91637	MFF1816D70101C
R165	301-0104-00			RES.,FXD,CMPSN:100K OHM,5%,0.5W	01121	EB1045
R168	315-0682-00			RES.,FXD,CMPSN:6.8K OHM,5%,0.25W	01121	CB6825
R170	315-0102-00			RES.,FXD,CMPSN:1K OHM,5%,0.25W	01121	CB1025
R172	321-0385-00			RES.,FXD,FILM:100K OHM,1%,0.125W	75042	CEATO-1003F
R174	321-0978-01			RES.,FXD,FILM:11.02K OHM,0.50%,0.125W	91637	MFF1816G11021D
R175	311-1565-00			RES.,VAR,NONWIR:250 OHM,20%,0.50W	73138	91A250ROM
R179	321-0287-00			RES.,FXD,FILM:9.53K OHM,1%,0.125W	75042	CEATO-9531F
R180	311-1563-00			RES.,VAR,NONWIR:1K OHM,20%,0.50W	73138	91A-10000M
R181	321-0066-00			RES.,FXD,FILM:47.5 OHM,1%,0.125W	75042	CEATO-47R50F
R185	321-0193-00			RES.,FXD,FILM:1K OHM,1%,0.125W	75042	CEATO-1001F
R187	321-0193-00			RES.,FXD,FILM:1K OHM,1%,0.125W	75042	CEATO-1001F
R190	315-0104-00			RES.,FXD,CMPSN:100K OHM,5%,0.25W	01121	CB1045
R192	315-0104-00			RES.,FXD,CMPSN:100K OHM,5%,0.25W	01121	CB1045
R197	321-0276-00			RES.,FXD,FILM:7.32K OHM,1%,0.125W	75042	CEATO-7321F
R198	321-0219-00	B010100	B019999	RES.,FXD,FILM:1.87K OHM,1%,0.125W	75042	CEATO-1871F
R198	321-0202-00	B020000		RES.,FXD,FILM:1.24K OHM,1%,0.125W	75042	CEATO-1241F
R199	321-0219-00	B010100	B019999	RES.,FXD,FILM:1.87K OHM,1%,0.125W	75042	CEATO-1871F
R199	321-0202-00	B020000		RES.,FXD,FILM:1.24K OHM,1%,0.125W	75042	CEATO-1241F
R200	321-0202-00	XB020000		RES.,FXD,FILM:1.24K OHM,1%,0.125W	75042	CEATO-1241F
R203	321-0473-00			RES.,FXD,FILM:825K OHM,1%,0.125W	75042	CEATO-8253F
R205	311-1554-00	B010100	B010369	RES.,VAR,NONWIR:200K OHM,20%,0.50W	73138	91A-20002M
R205	311-1553-00	B010370		RES.,VAR,NONWIR:250K OHM,20%,0.50W		
R208	315-0102-00			RES.,FXD,CMPSN:1K OHM,5%,0.25W	01121	CB1025
R210	315-0914-00			RES.,FXD,CMPSN:910K OHM,5%,0.25W	01121	CB9145
R212	321-0242-00			RES.,FXD,FILM:3.24K OHM,1%,0.125W	75042	CEATO-3241F
R215	311-1554-00			RES.,VAR,NONWIR:200K OHM,20%,0.50W	73138	91A-20002M
R217	321-1485-00			RES.,FXD,FILM:1.11M OHM,1%,0.125W	75042	CEATO-1114F
R218	321-0179-00			RES.,FXD,FILM:715 OHM,1%,0.125W	75042	CEATO-7150F
R220	321-0370-00			RES.,FXD,FILM:69.8K OHM,1%,0.125W	75042	CEATO-6982F
R224	321-0689-00			RES.,FXD,FILM:24.9K OHM,0.5%,0.125W	75042	CEATO-2492D
R225	321-1657-01			RES.,FXD,FILM:673.7 OHM,0.5%,0.125W	91637	MFF1816G673R7D
R230 ¹	315-0103-00			RES.,FXD,CMPSN:10K OHM,5%,0.25W	01121	CB1035
R232 ¹	315-0474-00			RES.,FXD,CMPSN:470K OHM,5%,0.25W	01121	CB4745
R235 ¹	315-0474-00			RES.,FXD,CMPSN:470K OHM,5%,0.25W	01121	CB4745

¹Remove for Option 2.

Electrical Parts List—DM 502

Ckt No.	Tektronix Part No.	Serial/Model No. Eff Dscont	Name & Description	Mfr Code	Mfr Part Number
R237 ¹	315-0103-00		RES.,FXD,CMPSN:10K OHM,5%,0.25W	01121	CB1035
R240 ¹	315-0104-00		RES.,FXD,CMPSN:100K OHM,5%,0.25W	01121	CB1045
R243 ¹	315-0104-00		RES.,FXD,CMPSN:100K OHM,5%,0.25W	01121	CB1045
R245 ¹	315-0104-00		RES.,FXD,CMPSN:100K OHM,5%,0.25W	01121	CB1045
R247 ¹	321-0117-00		RES.,FXD,FILM:162 OHM,1%,0.125W	75042	CEATO-1620F
R250 ¹	315-0103-00		RES.,FXD,CMPSN:10K OHM,5%,0.25W	01121	CB1035
R251 ¹	321-0222-00		RES.,FXD,FILM:2K OHM,1%,0.125W	75042	CEATO-2001F
R255 ¹	321-0365-02		RES.,FXD,FILM:61.9K OHM,0.5%,0.125W	91637	MFF1816D61901D
R257 ¹	322-0643-01		RES.,FXD,FILM:600K OHM,0.5%,0.25W	75042	CEBTO-6003D
R260 ¹	315-0104-00		RES.,FXD,CMPSN:100K OHM,5%,0.25W	01121	CB1045
R265 ¹	315-0683-00		RES.,FXD,CMPSN:68K OHM,5%,0.25W	01121	CB6835
R267 ¹	321-0106-00		RES.,FXD,FILM:124 OHM,1%,0.125W	75042	CEATO-1240F
R268 ¹	311-1731-00		RES.,VAR,NONWIR:TRMR,20 OHM,0.5W	73138	91A20R00M
R269 ¹	321-0182-00		RES.,FXD,FILM:768 OHM,1%,0.125W	75042	CEATO-7680F
R270 ¹	311-1222-00		RES.,VAR,NONWIR:100 OHM,20%,0.50W	80294	3386F-T04-500
R271 ¹	321-0176-00		RES.,FXD,FILM:665 OHM,1%,0.125W	75042	CEATO-6650F
R275 ¹	321-0446-00		RES.,FXD,FILM:432K OHM,1%,0.125W	75042	CEATO-4323F
R277 ¹	321-0397-00		RES.,FXD,FILM:133K OHM,1%,0.125W	75042	CEATO-1333F
R279 ¹	321-0219-00		RES.,FXD,FILM:1.87K OHM,1%,0.125W	75042	CEATO-1871F
R280 ¹	311-1564-00		RES.,VAR,NONWIR:500 OHM,20%,0.50W	73138	91A-500ROM
R282 ¹	321-0423-00		RES.,FXD,FILM:249K OHM,1%,0.125W	75042	CEATO-2493F
R285 ¹	321-0380-00		RES.,FXD,FILM:88.7K OHM,1%,0.125W	75042	CEATO-8872F
R290	303-0105-00		RES.,FXD,CMPSN:1M OHM,5%,1W	01121	GB1055
R291	315-0104-00		RES.,FXD,CMPSN:100K OHM,5%,0.25W	01121	CB1045
R293	321-0978-01		RES.,FXD,FILM:11.02K OHM,0.5%,0.125W	91637	MFF1816G11021D
R295	311-1565-00		RES.,VAR,NONWIR:250 OHM,20%,0.50W	73138	91A250ROM
R297	321-0385-00		RES.,FXD,FILM:100K OHM,1%,0.125W	75042	CEATO-1003F
R300	315-0184-00		RES.,FXD,CMPSN:180K OHM,5%,0.25W	01121	CB1845
R302	315-0104-00		RES.,FXD,CMPSN:100K OHM,5%,0.25W	01121	CB1045
R304	321-0369-00		RES.,FXD,FILM:68.1K OHM,1%,0.125W	75042	CEATO-6812F
R305	311-1228-00		RES.,VAR,NONWIR:10K OHM,20%,0.50W	80294	3389F-P31-103
R310	321-0184-00		RES.,FXD,FILM:806 OHM,1%,0.125W	75042	CEATO-8060F
R315	315-0393-00		RES.,FXD,CMPSN:39K OHM,5%,0.25W	01121	CB3935
R325	315-0200-00		RES.,FXD,CMPSN:20 OHM,5%,0.25W	01121	CB2005
R328	311-1559-00		RES.,VAR,NONWIR:10K OHM,20%,0.50W	73138	91A-10001M
R329	321-0255-00		RES.,FXD,FILM:4.42K OHM,1%,0.125W	75042	CEATO-4421F
R330	321-0306-00		RES.,FXD,FILM:15K OHM,1%,0.125W	75042	CEATO-1502F
R334	315-0103-00		RES.,FXD,CMPSN:10K OHM,5%,0.25W	01121	CB1035
R340	301-0201-00		RES.,FXD,CMPSN:200 OHM,5%,0.50W	01121	EB2015
R341	301-0201-00		RES.,FXD,CMPSN:200 OHM,5%,0.50W	01121	EB2015
R342	301-0201-00		RES.,FXD,CMPSN:200 OHM,5%,0.50W	01121	EB2015
R343	301-0201-00		RES.,FXD,CMPSN:200 OHM,5%,0.50W	01121	EB2015
R344	301-0201-00		RES.,FXD,CMPSN:200 OHM,5%,0.50W	01121	EB2015
R345	301-0201-00		RES.,FXD,CMPSN:200 OHM,5%,0.50W	01121	EB2015
R346	301-0201-00		RES.,FXD,CMPSN:200 OHM,5%,0.50W	01121	EB2015
R349	315-0152-00		RES.,FXD,CMPSN:1.5K OHM,5%,0.25W	01121	CB1525
R350	315-0152-00		RES.,FXD,CMPSN:1.5K OHM,5%,0.25W	01121	CB1525
R354	315-0152-00		RES.,FXD,CMPSN:1.5K OHM,5%,0.25W	01121	CB1525
R355	315-0152-00		RES.,FXD,CMPSN:1.5K OHM,5%,0.25W	01121	CB1525
R359	315-0152-00		RES.,FXD,CMPSN:1.5K OHM,5%,0.25W	01121	CB1525
R360	315-0152-00		RES.,FXD,CMPSN:1.5K OHM,5%,0.25W	01121	CB1525
R364	315-0152-00		RES.,FXD,CMPSN:1.5K OHM,5%,0.25W	01121	CB1525
R365	315-0152-00		RES.,FXD,CMPSN:1.5K OHM,5%,0.25W	01121	CB1525

¹Remove for Option 2.

Electrical Parts List—DM 502

Ckt No.	Tektronix Part No.	Serial/Model No.		Name & Description	Mfr	
		Eff	Dscont		Code	Mfr Part Number
R369	315-0472-00			RES.,FXD,CMPSN:4.7K OHM,5%,0.25W	01121	CB4725
R370	315-0201-00			RES.,FXD,CMPSN:200 OHM,5%,0.25W	01121	CB2015
R372	315-0201-00			RES.,FXD,CMPSN:200 OHM,5%,0.25W	01121	CB2015
R374	315-0103-00			RES.,FXD,CMPSN:10K OHM,5%,0.25W	01121	CB1035
R375	315-0103-00			RES.,FXD,CMPSN:10K OHM,5%,0.25W	01121	CB1035
R377	315-0201-00			RES.,FXD,CMPSN:200 OHM,5%,0.25W	01121	CB2015
R380	315-0103-00			RES.,FXD,CMPSN:10K OHM,5%,0.25W	01121	CB1035
R382	315-0201-00			RES.,FXD,CMPSN:200 OHM,5%,0.25W	01121	CB2015
R383	315-0201-00			RES.,FXD,CMPSN:200 OHM,5%,0.25W	01121	CB2015
R400	301-0681-00			RES.,FXD,CMPSN:680 OHM,5%,0.50W	01121	EB6815
R405	301-0681-00			RES.,FXD,CMPSN:680 OHM,5%,0.50W	01121	EB6815
R415	321-0371-00			RES.,FXD,FILM:71.5K OHM,1%,0.125W	75042	CEAT0-7152F
R418	304-0681-00			RES.,FXD,CMPSN:680 OHM,10%,1W	01121	GB6811
R422	321-0335-00			RES.,FXD,FILM:30.1K OHM,1%,0.125W	75042	CEAT0-3012F
R427	303-0511-00			RES.,FXD,CMPSN:510 OHM,5%,1W	01121	GB5115
R437	304-0181-00			RES.,FXD,CMPSN:180 OHM,10%,1W	01121	GB1811
R440	307-0106-00			RES.,FXD,CMPSN:4.7 OHM,5%,0.25W	01121	CB47G5
R450	315-0621-00			RES.,FXD,CMPSN:620 OHM,5%,0.25W	01121	CB6215
R452	315-0622-00			RES.,FXD,CMPSN:6.2K OHM,5%,0.25W	01121	CB6225
R453	315-0562-00			RES.,FXD,CMPSN:5.6K OHM,5%,0.25W	01121	CB5625
RT100	150-0131-00			LAMP,INCAND:0.025A 120V	71744	120PS
RT220	307-0472-00			RES.,THERMAL:100K 5%,NTC DISC	15454	10E104-JS
S100	260-1208-00			SWITCH,PUSH:DPDT	71590	2KAB010000-359
S110	263-1106-00			ACTR,ASSY,CAM SW:TIME/C M	80009	263-1106-00
S200	260-1332-00			SWITCH,PUSH:	80009	260-1332-00
T410	120-0958-00			XFMR,PWR:SDN	80009	120-0958-00
U120	156-0197-00			MICROCIRCUIT,LI:5 TRANSISTOR ARRAY	86684	CA3086
U135	156-0512-00			MICROCIRCUIT,LI:OPERATION AMPLIFIER	27014	LM308N
U195	156-0511-00			MICROCIRCUIT,LI:OPERATIONAL AMPLIFIER	18324	NE531V
U210	156-0067-00			MICROCIRCUIT,LI:OPERATIONAL AMPLIFIER	80009	156-0067-00
U220	156-0512-00			MICROCIRCUIT,LI:OPERATION AMPLIFIER	27014	LM308N
U250	156-0158-00			MICROCIRCUIT,LI:DUAL OPERATIONAL AMPLIFIER	18324	S5558V
U290	156-0477-00			MICROCIRCUIT,LI:ANAL SECT OF A/D SYS.,MOS	17856	LD111
U325	156-0402-00			MICROCIRCUIT,DI:TIMER	18324	NE555V
U335	156-0476-00			MICROCIRCUIT,LI:DIGTL SECT OF A/D SYS.,MOS	17856	LD110
U340	156-0128-00			MICROCIRCUIT,DI:SGL BCD TO 7-SEG DCDR/DRV	01295	SN7447AN
U345	156-0093-00			MICROCIRCUIT,DI:HEX.INVERTER	01295	SN7416N
U420	156-0496-00			MICROCIRCUIT,LI:VOLT REG.DUAL TRACKING	49956	RC4194D
VR120 ¹	152-0317-00			SEMICONV DEVICE:ZENER,0.25W,6.2V,5%	81483	1N3497
VR270 ¹	152-0317-00			SEMICONV DEVICE:ZENER,0.25W,6.2V,5%	81483	1N3497
VR300	152-0306-01			SEMICONV DEVICE:ZENER,0.4W,9.1V,5%	04713	1N960B
VR310	152-0317-00			SEMICONV DEVICE:ZENER,0.25W,6.2V,5%	81483	1N3497
VR400	152-0243-00			SEMICONV DEVICE:ZENER,0.4W,15V,5%	81483	1N965B
VR405	152-0243-00			SEMICONV DEVICE:ZENER,0.4W,15V,5%	81483	1N965B

¹Remove for Option 2.

SERVICE INFORMATION

SYMBOLS AND REFERENCE DESIGNATORS

Electrical components shown on the diagrams are in the following units unless noted otherwise:

- Capacitors = Values one or greater are in picofarads (pF).
Values less than one are in microfarads (μF).
- Resistors = Ohms (Ω)

Symbols used on the diagrams are based on ANSI Y32.2 – 1970.

Logic symbology is based on MIL-STD-806B in terms of positive logic. Logic symbols depict the logic function performed and may differ from the manufacturer's data.

The following special symbols are used on the diagrams:

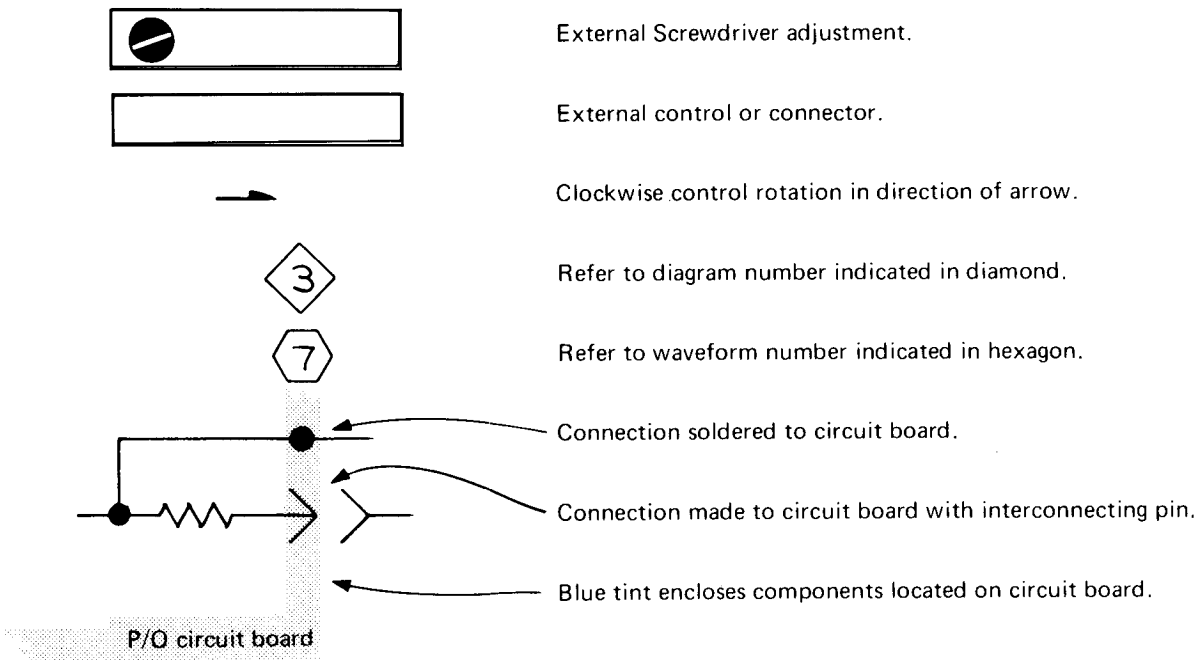

Service Available

Tektronix, Inc., provides complete instrument repair and adjustment at local Field Service Centers and at the Factory Service Center. Contact your local Tektronix Field Office or Representative for further information.

Refer to the TM 500 Series Power Module manuals for complete maintenance information.

Test Equipment

For calibration and a complete accuracy check of the DM 502, the following equipment is required:

Digital counter capable of reading to 25 kHz, Tektronix DC 504 or equivalent.

Dc voltmeter to .20 V, Tektronix DM 501, DM 502 or equivalent.

Dc voltage source to 1 kV.

Dc current source to 2 A.

Ac voltage source to 500 V rms, 40 Hz, 1 kHz and 10 kHz.

Ac current source to 2 A rms, 1 kHz.

Resistances to 20 M Ω .

Temperature source, about 0°C and 100°C.

Accuracy of calibration and performance checks depend upon the accuracy of the test equipment used.

Preparation

The DM 502 can be calibrated either fully installed in a TM 500 series power module, or connected to the power module via a flexible plug-in extender (Tektronix Part Number 067-0645-01). Remove the power module cabinet to make adjustments to the DM 502 inside the power module. DM 502 adjustments are located on the component side of the board. Remove the right side plug-in cover for access to the calibration adjustments. See the accompanying illustration for adjustment locations. Make adjustments at an ambient temperature between +20°C and +30°C (+68°F to +86°F). Allow 20 minutes warmup time. Recommended recalibration interval is every six months. Sometimes overall accuracy of the DM 502, on ranges affected by a specific adjustment, may be improved by compromising the adjustment, within specifications, from the exact setting called for in this procedure.

Checks and Adjustments

1. Check Power Supply Voltages. Using the dc voltmeter at the points shown on the illustration, check the power supplies for +5 V, ± 0.1 V, and ± 12 V, ± 0.6 V.

2. Adjust Clock Frequency. Connect the counter input to the point labeled clock in the accompanying illustration. Adjust R328, Clock, for a frequency of 20.48 kHz ± 0.2 kHz.

3. Adjust Integrator Zero. Set the range-function switch at the 2 DC VOLTS position. Short the HI and LO input binding posts together. Adjust C315, A-D Zero, for a display reading of all zeros \pm one count.

4. Adjust DC Calibration. Apply a known dc voltage near 1.9 V to the HI and LO binding posts (+ to the HI post). Make certain the range-function switch is in the 2 DC VOLTS position. Adjust R305, 2V Dc, for a display reading of the applied voltage \pm one count. Change the applied voltage to about 0.19 V and the range-function switch to the 200 MV position. Adjust R295, .2 V Dc, to display the applied voltage \pm one count.

5. Check DC Voltage Ranges. Apply known voltages, approximately 5% below each full scale value on the range-function switch to the HI and LO binding posts. Check that all ranges are within specifications.

INTERNAL ADJUSTMENT PROCEDURE

REAR INTERFACE CONNECTOR
ASSIGNMENTS & WIRE LOCATIONS

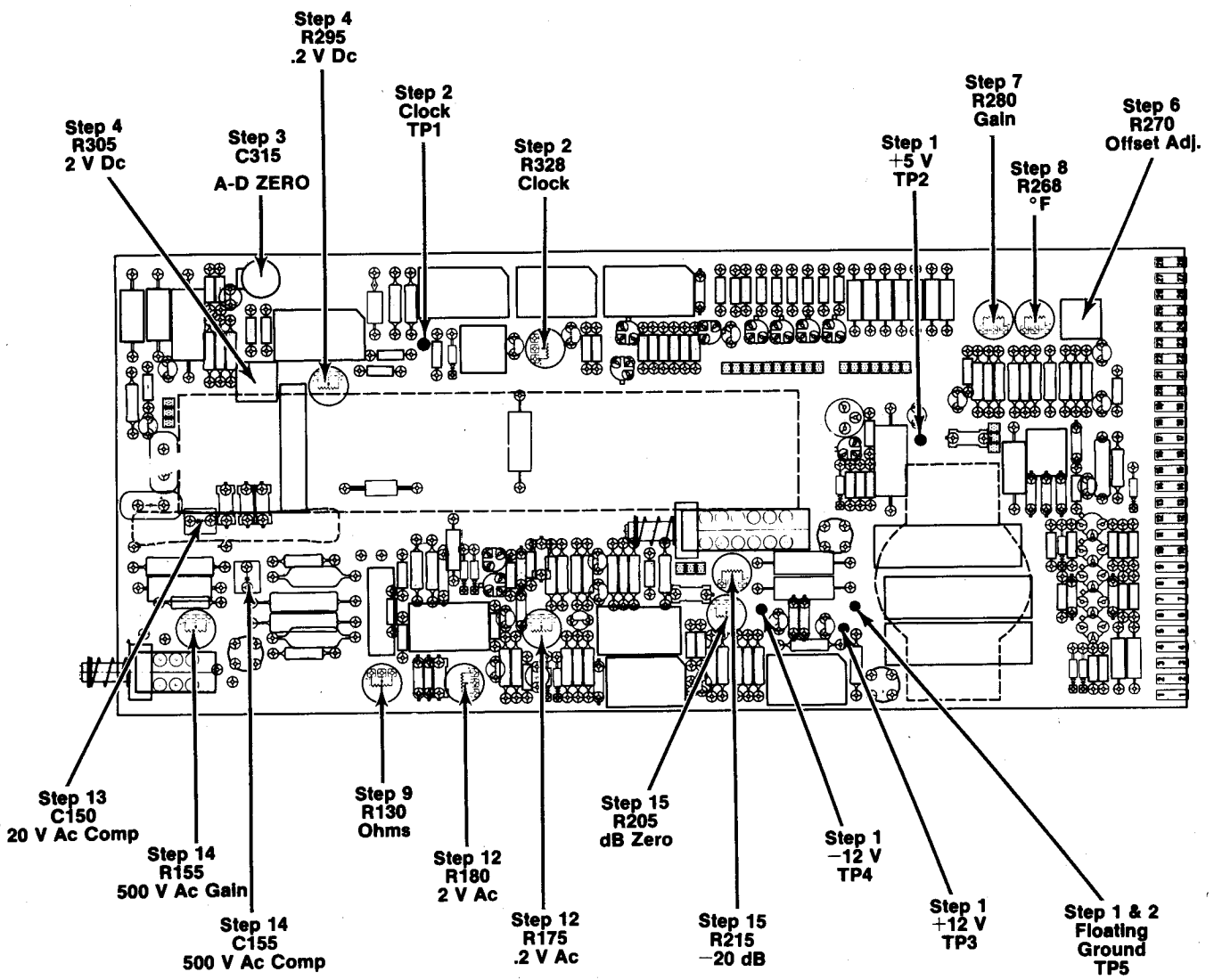

6. Adjust Temperature Offset. Place the range-function switch in the TEMP °C position. Connect a P6430 probe to the front panel connector labeled TEMP PROBE. Place the probe tip in a known environment (about 0°C and adjust R270, Offset Adj, for a display readout of the probe tip temperature ± one count.

7. Adjust Temperature Gain. Without changing the settings from the previous step, place the probe tip in a known environment (about 100°C). Now adjust R280, Gain, for a display reading of the probe tip temperature ± one count. Redo step 6 and this step until no interaction exists.

8. Adjust °F Calibration. With the probe tip at a temperature of (or near) 0°C change the range-function to the °F position. Adjust R268, °F, for a display reading of 32°F ± one count. (If the probe tip is not exactly at 0°C, convert the actual temperature in centigrade to Fahrenheit using:

$$^{\circ}\text{F} = \frac{9^{\circ}\text{C}}{5} + 32$$

9. Adjust Ohms Calibration. Set the range-function switch to the 200 K OHMS position. Connect a resistance of known accuracy near 190 kΩ to the HI and LO binding posts. Adjust R130, Ohms, for a display readout of the known resistance ± one count.

10. Check Resistance Ranges. Connect resistances of known accuracy, approximately 5% below full scale values as shown on the range-function switch, to the HI and LO binding posts. Check that all OHMS ranges are within specified accuracy.

11. Check DC mA Ranges. Apply accurately known dc currents, approximately 5%, below full scale values as shown on the range-function switch, to the HI and LO binding posts. Check that all DC mA positions are within specifications.

12. Adjust AC Voltage Calibration. Set the range-function switch to the 2 AC VOLTS position. Connect an accurately known ac voltage near 1.9 volts rms at 1 kHz to the HI and LO binding posts. Adjust R180, 2 V Ac, for a

display reading of the applied voltage ± one count. Now switch the range-function switch to the 200 MV AC VOLTS position and apply an accurately known voltage near 190 mV to the input terminals. Adjust R175, .2 V Ac, for a display reading of the applied voltage ± one count.

13. Adjust 20 V AC Compensation. Set the range-function switch to the 20 AC VOLTS position. Connect a known ac voltage near 19 volts rms at a frequency of 1 kHz to the HI and LO binding posts. Adjust C150, 20 V Ac Comp, for a display reading of the applied voltage ± one count. Now switch to the 200 AC VOLTS position and apply an accurately known ac voltage near 190 volts rms. Check that the display reading is the applied voltage within specifications. If not, redo this step, slightly compromising the adjustment in the 20 AC VOLTS position, until both readings are within specifications.

14. Adjust 500 V AC Gain and Compensation. Set the range-function switch to the 500 AC VOLTS position. Connect an accurately known ac voltage near 500 V ac rms at 100 Hz to the HI and LO binding posts. Adjust R155, 500 V Ac Gain, for a display reading of the applied voltage ± one count. Now change the frequency of the applied voltage to 10 kHz and adjust C155, 500 V Ac Comp, for a display reading of the applied voltage ± one count. These adjustments interact. Redo both as required for accurate calibration.

15. Adjust dB Zero and -20 dB. Make certain the jumper is in the dBm position. Set the range-function switch to the 2 AC VOLTS position and push the dB pushbutton. Apply 0.07746V ac rms at 1 kHz to the HI and LO binding posts. Adjust R205, dB Zero, for a display reading of all zeros ± three counts. Now apply 0.00869 V ac rms at 1 kHz and adjust R215, -20 dB, for a display reading of -19.00 ± three counts. Apply 0.69036 V ac rms at 1 kHz and check for a display reading of +19.00, within specification limits by at least ten counts. Now switch the jumper to the dBV position, apply 1.0000 V ac rms at 1 kHz and check for a display reading of all zeros within specification limits by at least ten counts.

16. Check All AC mA Ranges. Apply an accurately known ac current at a frequency of 1 kHz, with an amplitude of approximately 5% below full scale values as shown on the range-function switch, to the HI and LO binding posts. Check each AC mA position for accuracy within specifications.

olarity

SD

nd SD

To 26A 3rd SD
To 25A LSD
To 19A BCD 1
To 20A BCD 4

Component side (B)

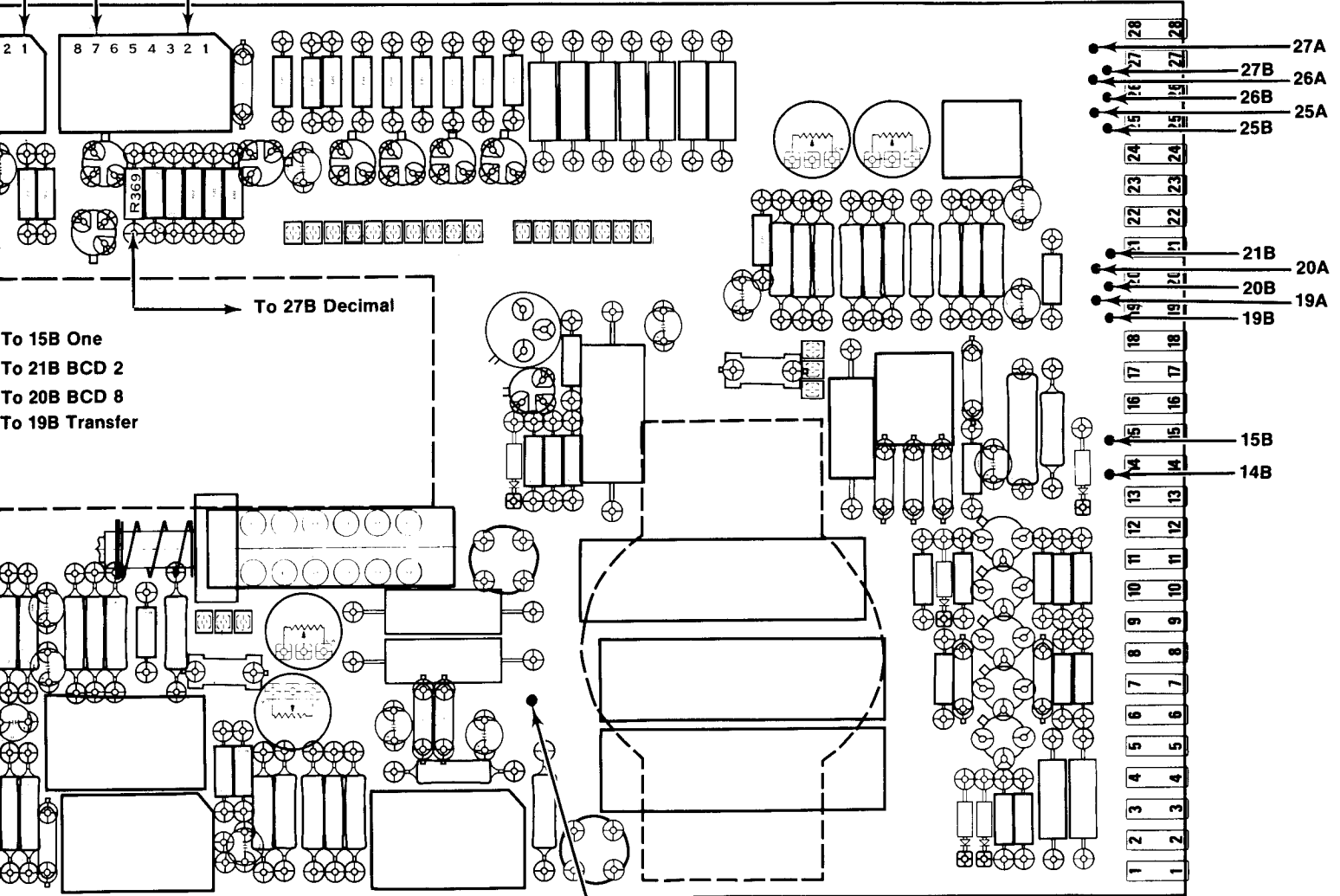

To 15B One
To 21B BCD 2
To 20B BCD 8
To 19B Transfer

To 27B Decimal

To 27A Common

- 28
 - 27
 - 26
 - 25
 - 24
 - 23
 - 22
 - 21
 - 20
 - 19
 - 18
 - 17
 - 16
 - 15
 - 14
 - 13
 - 12
 - 11
 - 10
 - 9
 - 8
 - 7
 - 6
 - 5
 - 4
 - 3
 - 2
 - 1
- 27A
 - 26A
 - 25A
 - 21B
 - 20A
 - 19A
 - 15B
 - 14B

LOCATIONS FOR USER WIRED REAR INTERFACE CONNECTIONS

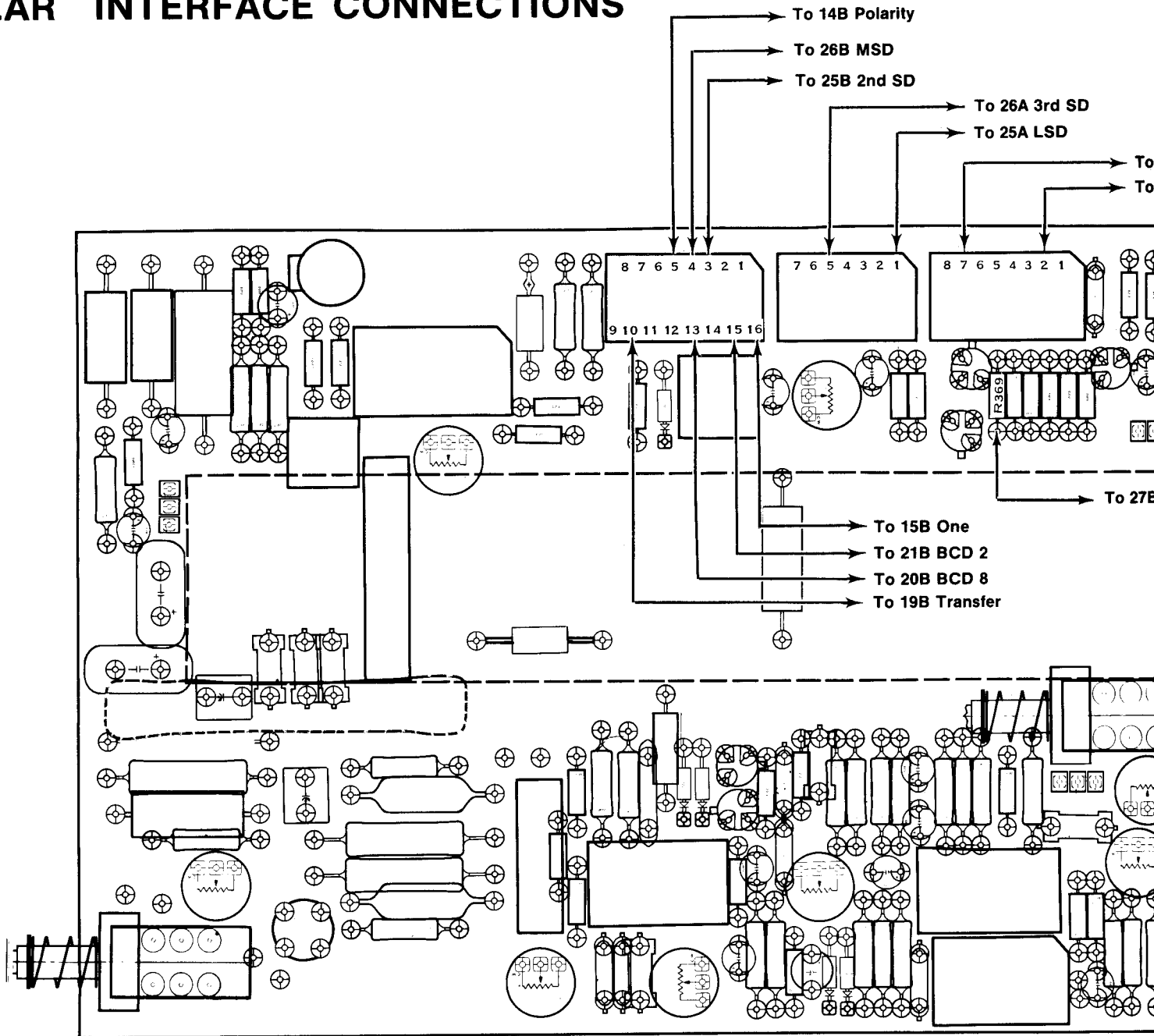

REAR INTERFACE CONNECTOR ASSIGNMENTS

REAR INTERFACE CONNECTOR ASSIGNMENTS & WIRE LOCATIONS

Remarks	Maximum Recommended Leads	Active Level	Output or Input	Pin B	Pin A	Output or Input	Active Level	Maximum Recommended Leads	Remarks
			HI Input	28	28	LO Input			
	*	H	Decimal Out	27	27	Common			Floating Common Use as common for all data outputs.
	*	H	MSD Out	26	26	3rd SD Out	H	*	
	*	H	2nd SD Out	25	25	LSD Out	H	*	
Chassis Gnd			Temp Gnd	24	24	Temp Out			10 mV/°. Use ≥10 kΩ load
				23	23				
				22	22				
	*	H	BCD Out 2	21	21				
	*	H	BCD Out 8	20	20	BCD Out 4	H	*	
	*	L	Transfer	19	19	BCD Out 1	H	*	
				18	18				
				17	17				
				16	16				
Multiplexed	*	L	One Out	15	15				
	*	H+	Polarity Out	14	14				
			'25 VAC Winding	13	13	'25 VAC Winding			
			'±33.5 V filtered DC	12	12				
			Collector lead of PNP Series-Pass	11	11	Base lead of PNP Series-Pass			
			Transformer shield	10	10	Emitter lead of PNP Series-Pass			
			'33.5 V common	9	9	'33.5 V common			
				8	8	'-33.5 V filtered DC			
			Collector lead of NPN Series-Pass	7	7	Emitter lead of NPN Series-Pass			
			Not Used	6	6	Base lead of NPN Series-Pass			
			17.5 VAC winding	5	5	17.5 VAC winding			
			+11.5 V common	4	4	+11.5 V common			
			+11.5 V common	3	3	+11.5 V common			
			+11.5 V filtered DC	2	2	+11.5 V filtered DC			
			'25 VAC winding	1	1	'25 VAC winding			
				B	A				

Rear-view of plug-in

*These outputs must be buffered before using them to drive external inputs. See text for suitable buffering circuit.

¹Used in the DM 502.

Only the Temp Out, Temp Gnd, and HI and LO inputs are factory wired. The others must be installed by the user. See accompanying illustration for jumper locations for connections. BCD outputs are serialized by digits in an 8-4-2-1 code. This code is not valid when the MSD line is high. When the MSD and the one are high the fourth significant digit is a one. A two may also be encoded as well as overrange information.

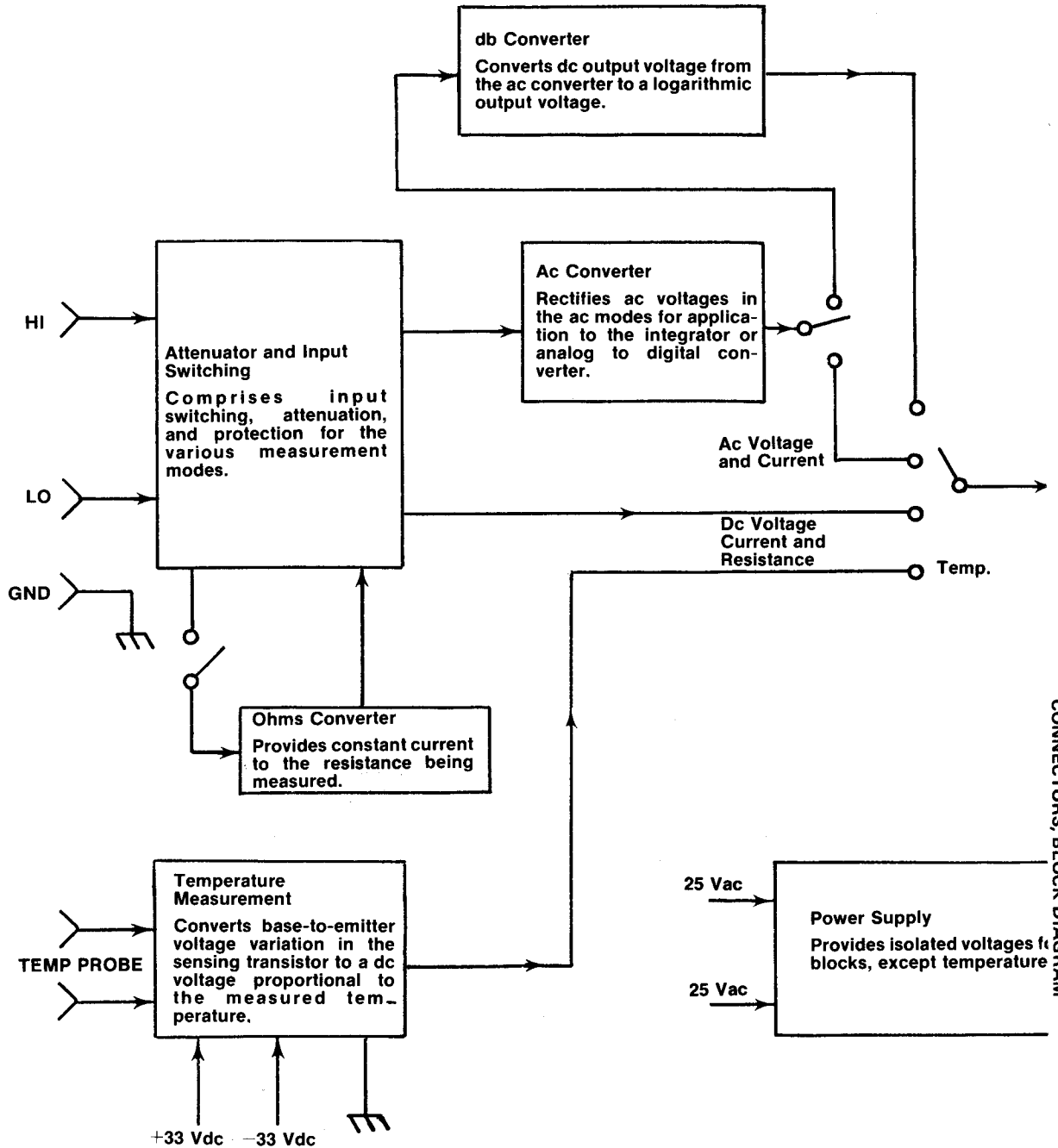

FRONT PANEL CONTROLS & CONNECTORS; BLOCK DIAGRAM

BLOCK DIAGRAM

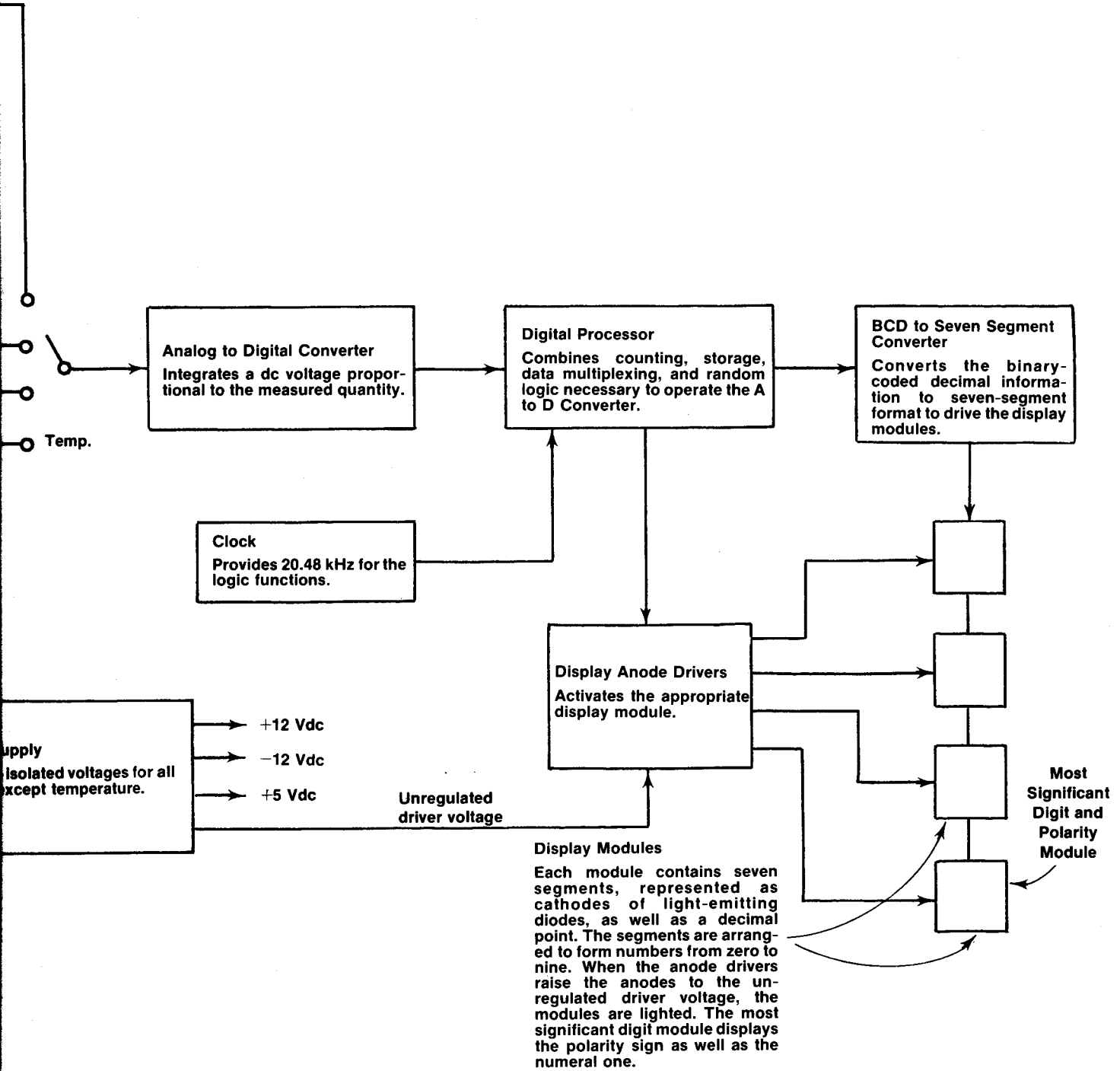

CONTROLS AND CONNECTORS

Display Readout
 3 1/2 digit LED readout with decimal point positioned by range function switch. Resolution is 0.05% of range except temperature which is 0.1°.

INPUT Binding Posts
 Binding posts for application of unknown voltage, current or resistance. May be floated 1 kV above ground.

Ground Binding Post
 Chassis Ground

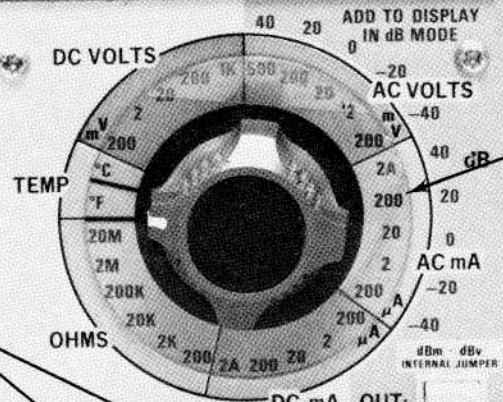

Range Function Switch
 Selects all ranges and functions.

dB
 Button in selects dB readout in ac modes.

INPUT Pushbutton
 Button OUT transfers input to front panel. Button in rear interface connector. Does not switch TEMP input.

TEMP PROBE Connector
 Mates with P6430 probe connector. Also used with other temperature sensing devices.

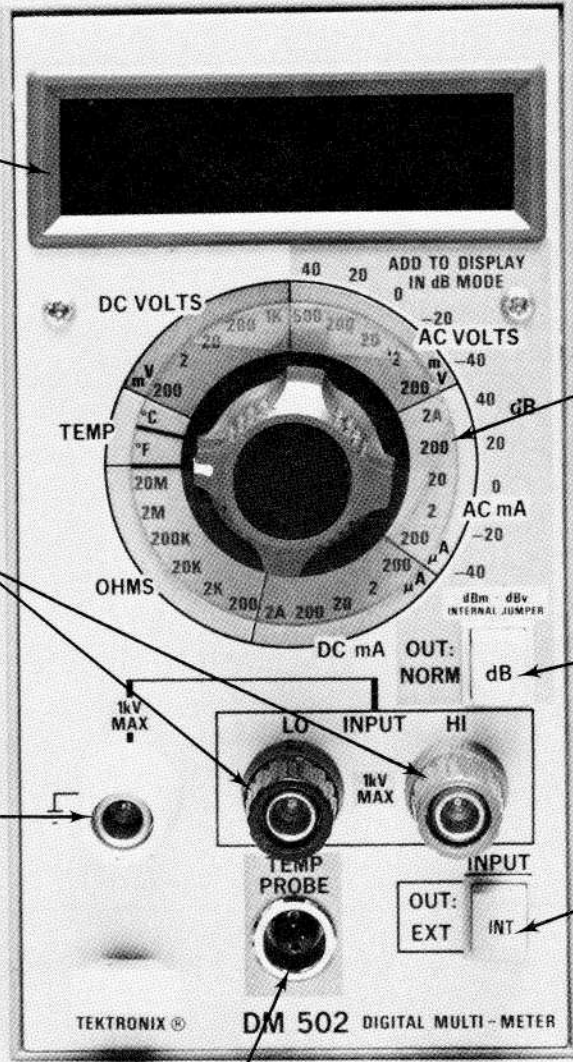

TS LOCATION GRID

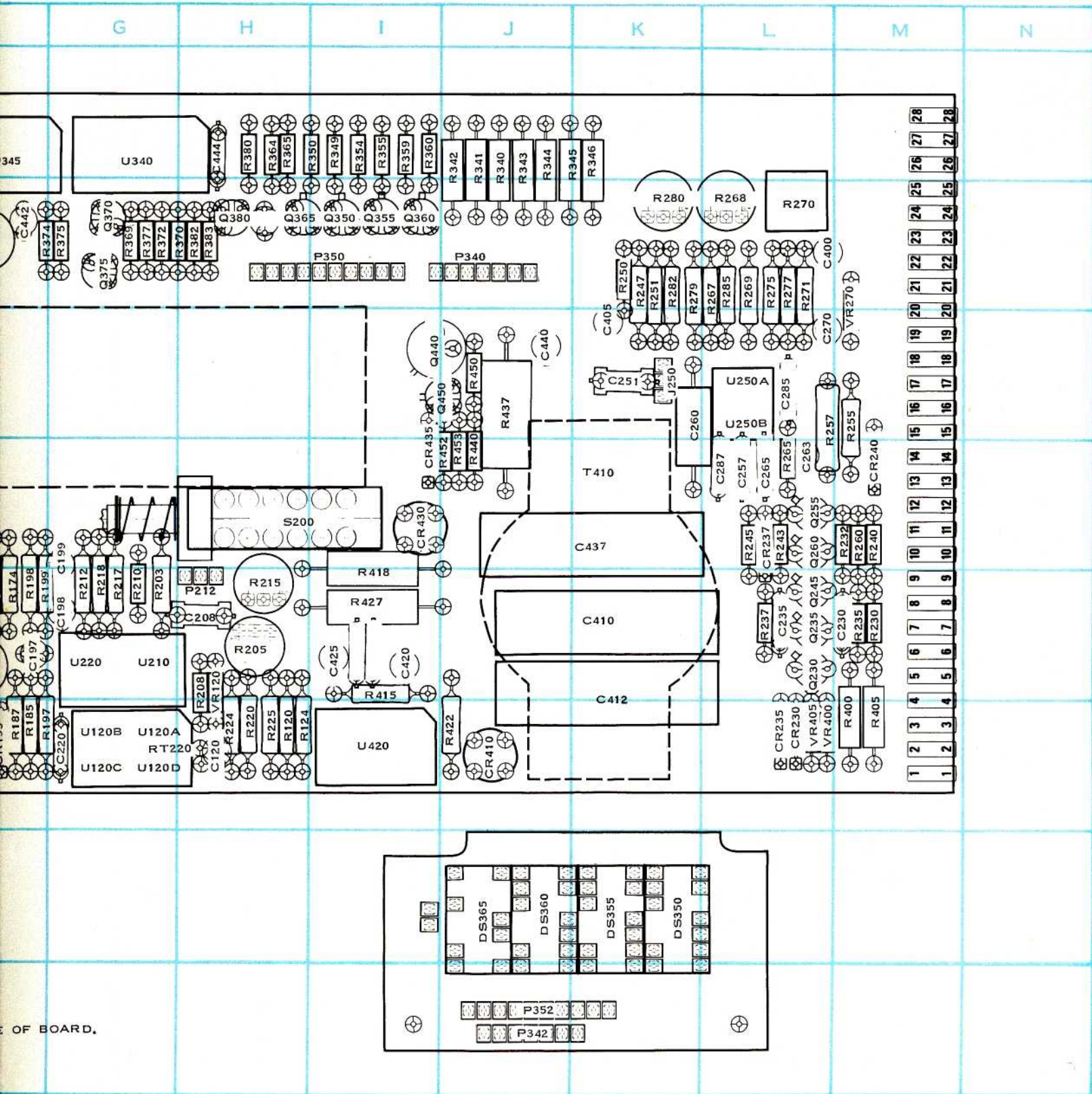

E OF BOARD.

PARTS LOCATION

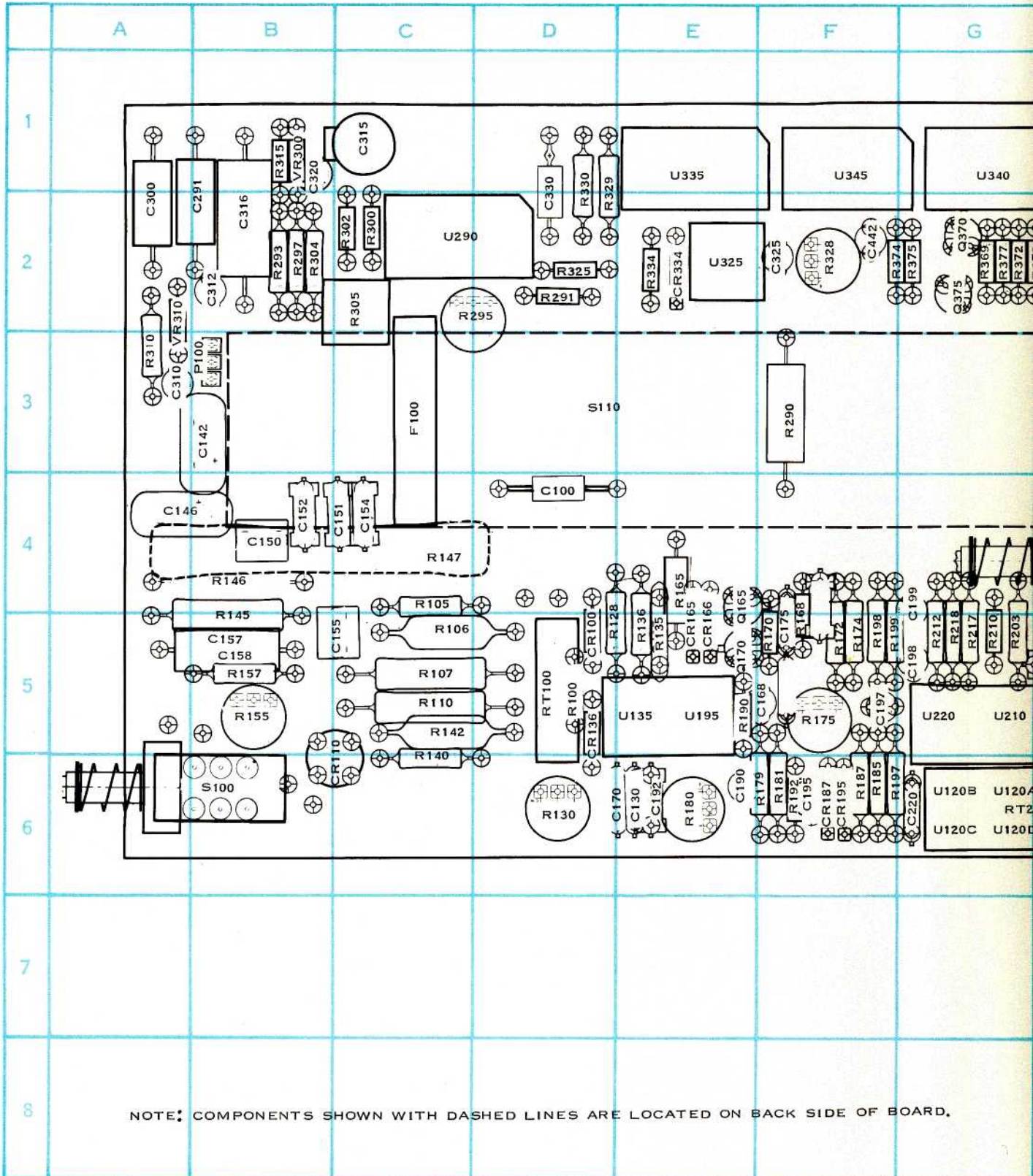

PARTS LOCATION GRID

CKT NO	GRID LOC	CKT NO	GRID LOC	CKT NO	GRID LOC	CKT NO	GRID LOC	CKT NO	GRID LOC
C100	D4	CR334	E2	R172	F5	R334	E2	VR120	H5
C120	H6	CR410	J6	R174	F5	R340	J1	VR270	M2
C130	E6	CR430	I4	R175	F5	R341	J1	VR300	B1
C142	B3	CR435	I4	R179	F6	R342	J1	VR310	A2
C146	A4			R180	E6	R343	J1	VR400	L6
C150	B4			R181	F6	R344	J1	VR405	L6
C151	C4	DS350	K7	R185	F6	R345	J1		
C152	B4	DS355	K7	R187	F6	R346	K1		
C154	C4	DS360	J7	R190	E5	R349	I1		
C155	C5	DS365	J7	R192	F6	R350	I1		
C157	B5			R197	F6	R354	I1		
C158	B5			R198	F5	R355	I1		
C168	F5	F100	C3	R199	F5	R359	I1		
C170	E6			R203	G5	R360	I1		
C175	F5			R205	H5	R364	H1		
C190	E6	J250	K3	R208	H5	R365	H1		
C192	E6			R210	G5	R369	G2		
C195	F6			R212	G5	R370	G2		
C197	F5	P100	B3	R215	H5	R372	G2		
C198	G5	P212	H5	R217	G5	R374	F2		
C199	G4	P340	J2	R218	G5	R375	G2		
C208	H5	P342	J8	R220	H6	R377	G2		
C220	G6	P350	I2	R224	H6	R380	H1		
C230	M5	P352	K8	R225	H6	R382	H2		
C235	L5			R230	M5	R383	H2		
C251	K3			R232	M4	R400	M6		
C257	L4	Q165	E4	R235	M5	R405	M6		
C260	K3	Q170	E5	R237	L5	R415	I5		
C263	L4	Q230	L5	R240	M4	R418	I5		
C265	L4	Q235	L5	R243	L4	R422	J6		
C270	L3	Q245	L5	R245	L4	R427	I5		
C285	L3	Q255	L4	R247	K2	R437	J3		
C287	L4	Q260	L4	R250	K2	R440	J4		
C291	B2	Q350	I2	R251	K2	R450	J3		
C300	A2	Q355	I2	R255	M3	R452	J4		
C310	A3	Q360	I2	R257	L3	R453	J4		
C312	B2	Q365	H2	R260	M4				
C315	C1	Q370	G2	R265	L4				
C316	B2	Q375	G2	R267	L2				
C320	B1	Q380	H2	R268	L2				
C325	F2	Q440	I3	R269	L2	RT100	D5		
C330	D1	Q450	J3	R270	L2	RT220	G6		
C400	L2			R271	L2				
C405	K3	R100	D5	R275	L2				
C410	K5	R105	C4	R277	L2	S100	B6		
C412	K5	R106	C5	R279	K2	S110	D3		
C420	I5	R107	C5	R280	K2	S200	H4		
C425	I5	R110	C5	R282	K2				
C437	K4	R120	H6	R285	L2				
C440	J3	R124	H6	R290	F3	T410	K4		
C442	F2	R128	D5	R291	D2				
C444	H1	R130	D6	R293	B2				
		R135	E5	R295	C2	U120	G6		
CR100	D5	R136	E5	R297	B2	U135	E5		
CR110	C6	R140	C5	R300	C2	U195	E5		
CR136	D5	R142	C5	R302	C2	U210	G5		
CR165	E5	R145	B4	R304	B2	U220	G5		
CR166	E5	R146	B4	R305	C2	U250	L3		
CR187	F6	R147	C4	R310	A3	U290	C2		
CR195	F6	R155	B5	R315	B1	U325	E2		
CR230	L6	R157	B5	R325	D2	U335	E1		
CR235	L6	R165	E4	R328	F2	U340	G1		
CR237	L4	R168	F4	R329	D1	U345	F1		
CR240	M4	R170	F5	R330	D1	U420	I6		

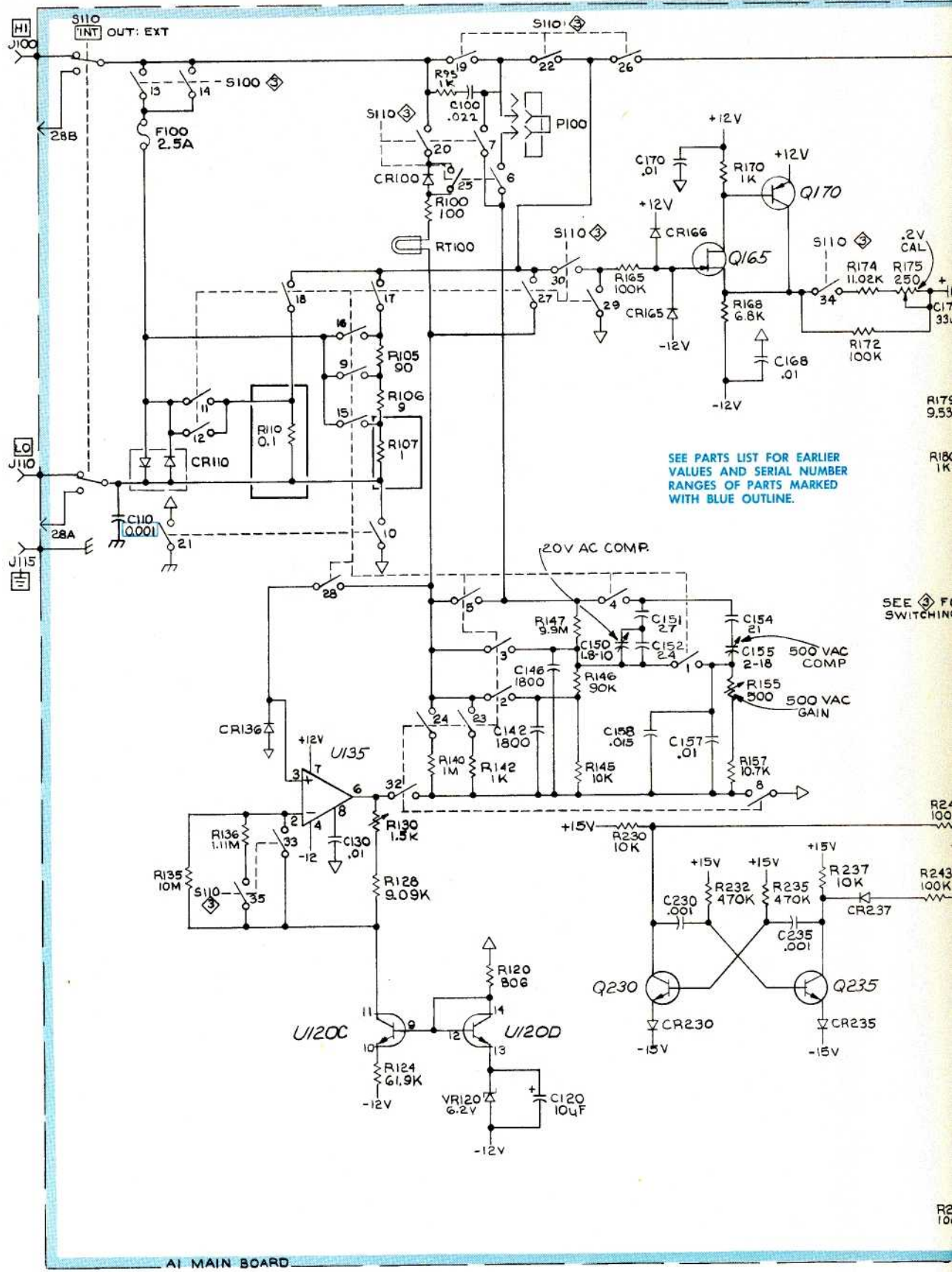

+ DM 502

REV. B, NOV. 1974

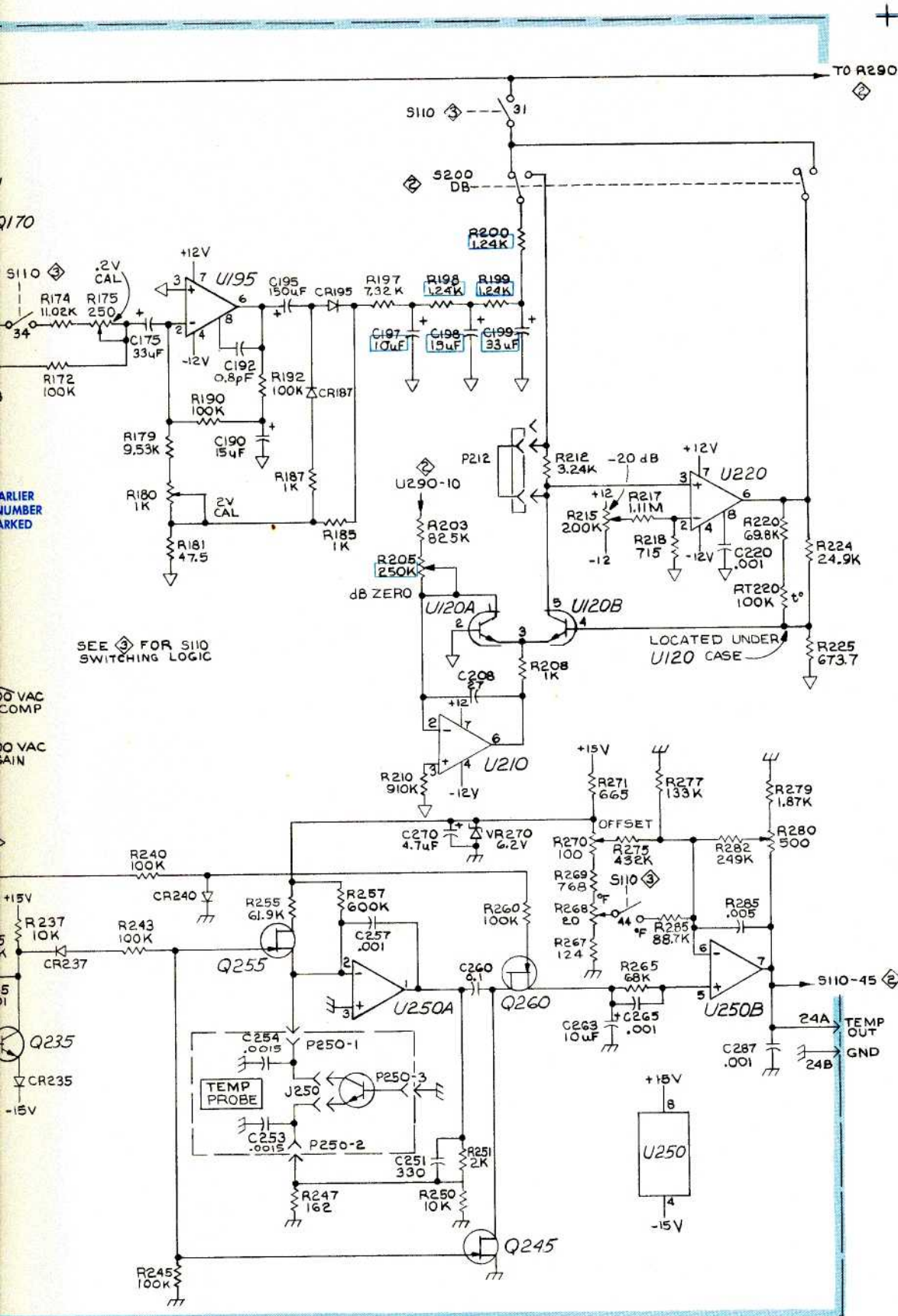

SEE \diamond FOR S110 SWITCHING LOGIC

LOCATED UNDER U120 CASE

ATTENUATORS & CONVERSION CIRCUITS \diamond NS 8-12-74

ATTENUATORS & CONVERSION CIRCUITS

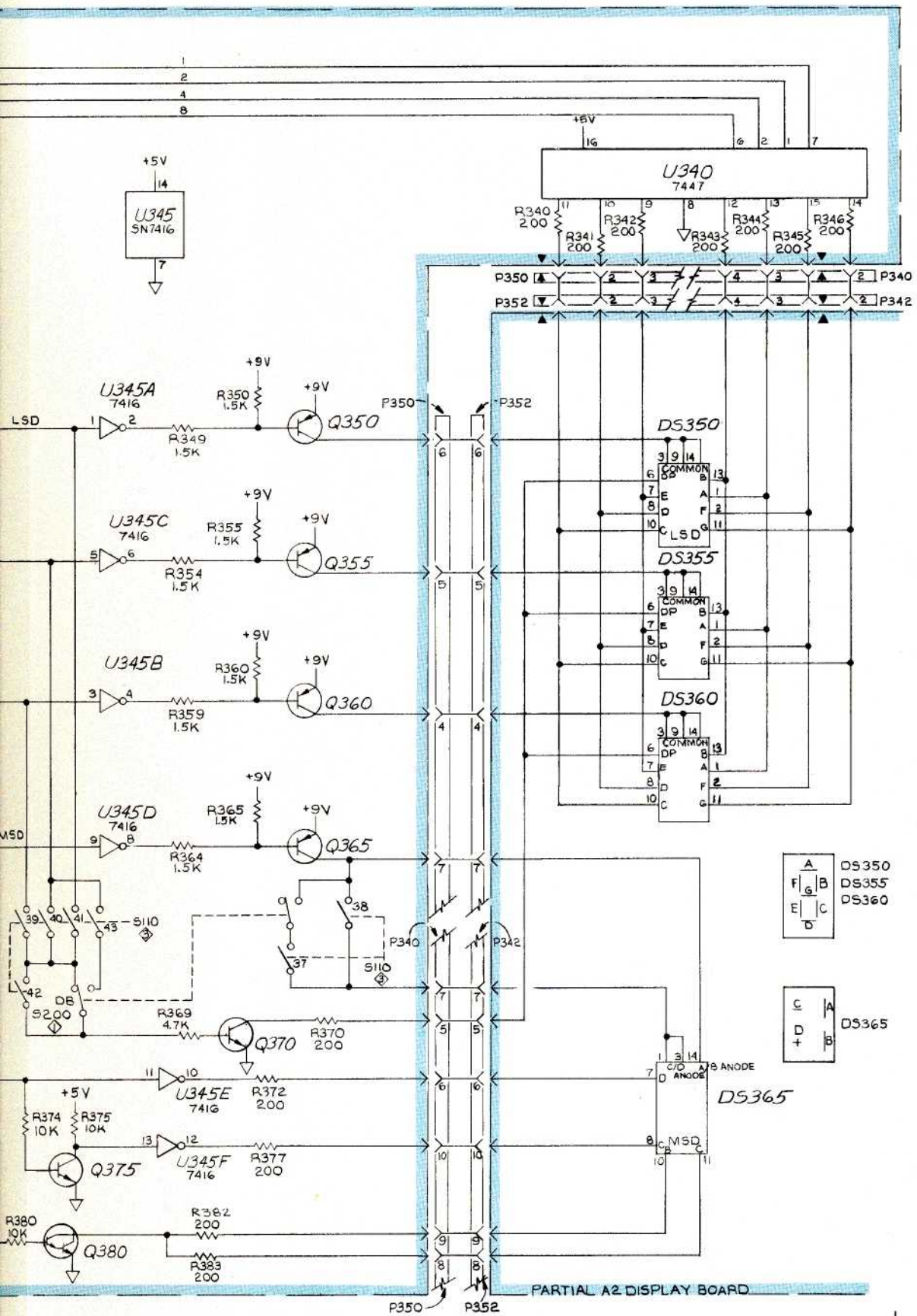

INTEGRATOR, A/D CONVERTER, DISPLAY

+

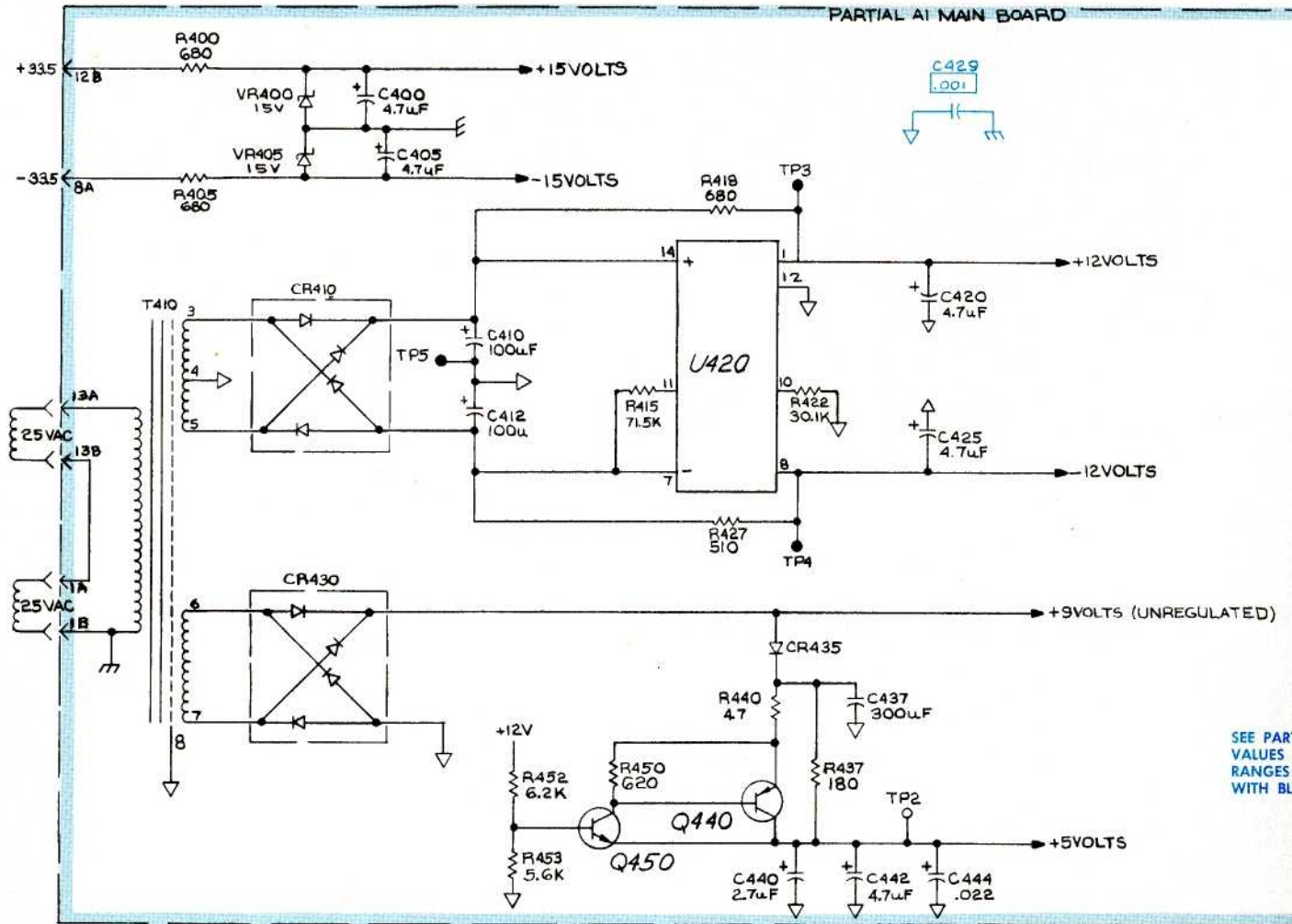

SEE PARTS LIST
VALUES AND SE
RANGES OF PA
WITH BLUE OUT

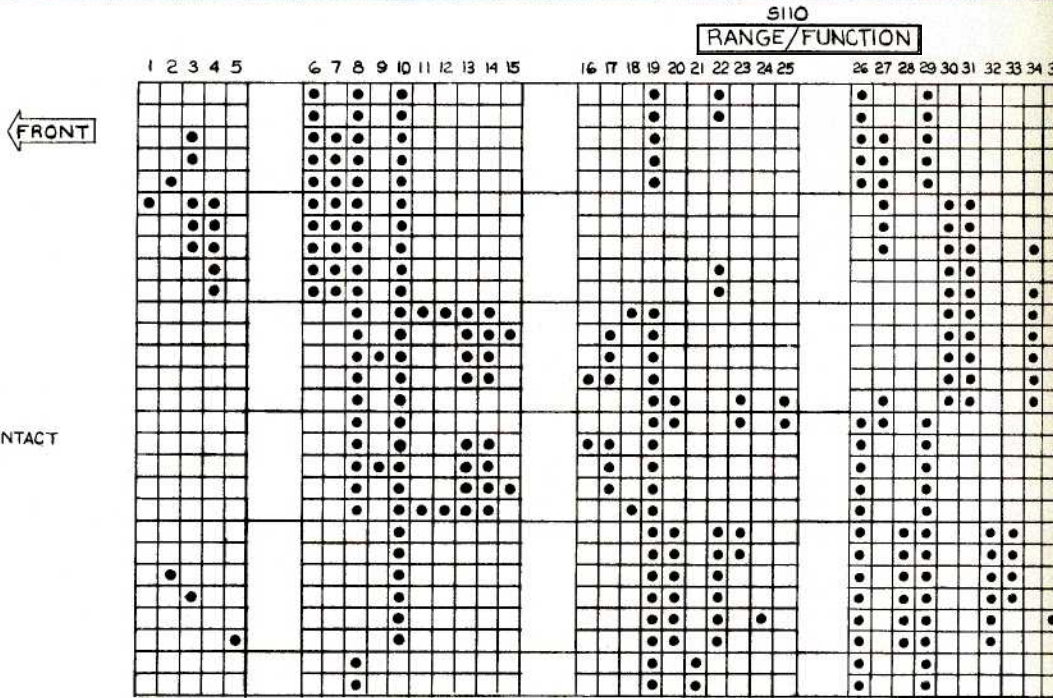

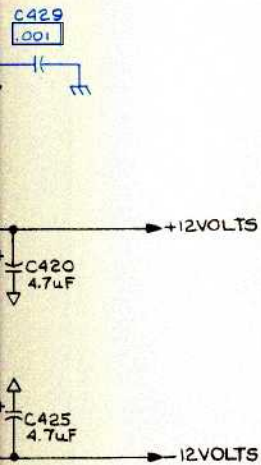

+9VOLTS (UNREGULATED)

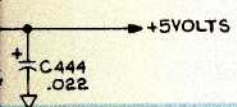

SEE PARTS LIST FOR EARLIER VALUES AND SERIAL NUMBER RANGES OF PARTS MARKED WITH BLUE OUTLINE.

S110										CCW																			
RANGE/FUNCTION																													
16	17	18	19	20	21	22	23	24	25	26	27	28	29	30	31	32	33	34	35	36	37	38	39	40	41	42	43	44	45
										200MV										DC VOLTS									
										2																			
										20										AC V									
										200																			
										1KV										dB									
										500 — 40																			
										200 — 20										AC mA									
										20 — 0																			
										2 — -20										DC mA									
										200 MV — -40																			
										2A — 40										Ohms									
										200 — 20																			
										20 — 0																			
										2 — -20																			
										200uA — -40																			
										200 uA																			
										2																			
										20																			
										200																			
										2A																			
										200																			
										2K																			
										20K																			
										200K																			
										2M																			
										20M																			
										PF																			
										PC																			

REPLACEABLE MECHANICAL PARTS

PARTS ORDERING INFORMATION

Replacement parts are available from or through your local Tektronix, Inc. Field Office or representative.

Changes to Tektronix instruments are sometimes made to accommodate improved components as they become available, and to give you the benefit of the latest circuit improvements developed in our engineering department. It is therefore important, when ordering parts, to include the following information in your order: Part number, instrument type or number, serial number, and modification number if applicable.

If a part you have ordered has been replaced with a new or improved part, your local Tektronix, Inc. Field Office or representative will contact you concerning any change in part number.

Change information, if any, is located at the rear of this manual.

SPECIAL NOTES AND SYMBOLS

X000 Part first added at this serial number
00X Part removed after this serial number

FIGURE AND INDEX NUMBERS

Items in this section are referenced by figure and index numbers to the illustrations.

INDENTATION SYSTEM

This mechanical parts list is indented to indicate item relationships. Following is an example of the indentation system used in the description column.

1 2 3 4 5 *Name & Description*

Assembly and/or Component

Attaching parts for Assembly and/or Component

---*---

Detail Part of Assembly and/or Component

Attaching parts for Detail Part

---*---

Parts of Detail Part

Attaching parts for Parts of Detail Part

---*---

Attaching Parts always appear in the same indentation as the item it mounts, while the detail parts are indented to the right. Indented items are part of, and included with, the next higher indentation. The separation symbol ---*--- indicates the end of attaching parts.

Attaching parts must be purchased separately, unless otherwise specified.

ITEM NAME

In the Parts List, an Item Name is separated from the description by a colon (:). Because of space limitations, an Item Name may sometimes appear as incomplete. For further Item Name identification, the U.S. Federal Cataloging Handbook H6-1 can be utilized where possible.

ABBREVIATIONS

#	INCH NUMBER SIZE	ELECTRN	ELECTRON	IN	INCH	SE	SINGLE END
ACTR	ACTUATOR	ELEC	ELECTRICAL	INCAND	INCANDESCENT	SECT	SECTION
ADPTR	ADAPTER	ELECTLT	ELECTROLYTIC	INSUL	INSULATOR	SEMICOND	SEMICONDUCTOR
ALIGN	ALIGNMENT	ELEM	ELEMENT	INTL	INTERNAL	SHLD	SHIELD
AL	ALUMINUM	EPL	ELECTRICAL PARTS LIST	LPHLDR	LAMPHOLDER	SHLDR	SHOULDERED
ASSEM	ASSEMBLED	EQPT	EQUIPMENT	MACH	MACHINE	SKT	SOCKET
ASSY	ASSEMBLY	EXT	EXTERNAL	MECH	MECHANICAL	SL	SLIDE
ATTEN	ATTENUATOR	FIL	FILLISTER HEAD	MTG	MOUNTING	SLFLKG	SELF-LOCKING
AWG	AMERICAN WIRE GAGE	FLEX	FLEXIBLE	NIP	NIPPLE	SLVG	SLEEVING
BD	BOARD	FLH	FLAT HEAD	NON WIRE	NOT WIRE WOUND	SPR	SPRING
BRKT	BRACKET	FLTR	FILTER	OBD	ORDER BY DESCRIPTION	SQ	SQUARE
BRS	BRASS	FR	FRAME or FRONT	OD	OUTSIDE DIAMETER	SST	STAINLESS STEEL
BRZ	BRONZE	FSTNR	FASTENER	OVH	OVAL HEAD	STL	STEEL
BSHG	BUSHING	FT	FOOT	PH BRZ	PHOSPHOR BRONZE	SW	SWITCH
CAB	CABINET	FXD	FIXED	PL	PLAIN or PLATE	T	TUBE
CAP	CAPACITOR	GSKT	GASKET	PLSTC	PLASTIC	TERM	TERMINAL
CER	CERAMIC	HDL	HANDLE	PN	PART NUMBER	THD	THREAD
CHAS	CHASSIS	HEX	HEXAGON	PNH	PAN HEAD	THK	THICK
CKT	CIRCUIT	HEX HD	HEXAGONAL HEAD	PWR	POWER	TNSN	TENSION
COMP	COMPOSITION	HEX SOC	HEXAGONAL SOCKET	RCPT	RECEPTACLE	TPG	TAPPING
CONN	CONNECTOR	HLCPS	HELICAL COMPRESSION	RES	RESISTOR	TRH	TRUSS HEAD
COV	COVER	HLEXT	HELICAL EXTENSION	RGD	RIGID	V	VOLTAGE
CPLG	COUPLING	HV	HIGH VOLTAGE	RLF	RELIEF	VAR	VARIABLE
CRT	CATHODE RAY TUBE	IC	INTEGRATED CIRCUIT	RTNR	RETAINER	W/	WITH
DEG	DEGREE	ID	INSIDE DIAMETER	SCH	SOCKET HEAD	WSHR	WASHER
DWR	DRAWER	IDENT	IDENTIFICATION	SCOPE	OSCILLOSCOPE	XFMR	TRANSFORMER
		IMPLR	IMPELLER	SCR	SCREW	XSTR	TRANSISTOR

CROSS INDEX MFR. CODE NUMBER TO MANUFACTURER

MFR.CODE	MANUFACTURER	ADDRESS	CITY,STATE,ZIP
0000A	LEMO USA	2015 2ND ST.	BERKLEY, CA 94710
0000C	GETTIG ENGINEERING AND MANUFACTURING CO.		SPRINGMILL, PA 16875
00779	AMP, INC.	P. O. BOX 3608	HARRISBURG, PA 17105
01295	TEXAS INSTRUMENTS, INC., SEMICONDUCTOR GROUP	P. O. BOX 5012	DALLAS, TX 75222
05820	WAKEFIELD ENGINEERING, INC.	AUDUBON ROAD	WAKEFIELD, MA 01880
08261	SPECTRA-STRIP CORP.	7100 LAMPSON AVE.	GARDEN GROVE, CA 92642
22526	BERG ELECTRONICS, INC.	YOUK EXPRESSWAY	NEW CUMBERLAND, PA 17070
23499	GAVITT WIRE AND CABLE, DIVISION OF RSC INDUSTRIES, INC.	455 N. QUINCE ST.	ESCONDIDO, CA 92025
45722	USM CORP., PARKER-KALON FASTENER DIV.	1 PEEKAY DRIVE	CLIFTON, NJ 07014
58474	SUPERIOR ELECTRIC CO., THE	383 MIDDLE ST.	BRISTOL, CT 06010
71590	CENTRALAB ELECTRONICS, DIV. OF GLOBE-UNION, INC.	5757 N. GREEN BAY AVE.	MILWAUKEE, WI 53201
73743	FISCHER SPECIAL MFG. CO.	446 MORGAN ST.	CINCINNATI, OH 45206
74445	HOLO-KROME CO.	31 BROOK ST. WEST	HARTFORD, CT 06110
77250	PHEOLL MANUFACTURING CO., DIVISION OF ALLIED PRODUCTS CORP.	5700 W. ROOSEVELT RD.	CHICAGO, IL 60650
78189	ILLINOIS TOOL WORKS, INC. SHAKEPROOF DIVISION	ST. CHARLES ROAD	ELGIN, IL 60120
80009	TEKTRONIX, INC.	P. O. BOX 500	BEAVERTON, OR 97077
82647	TEXAS INSTRUMENTS, INC., CONTROL PRODUCTS DIV.	34 FOREST ST.	ATTLEBORO, MA 02703
83385	CENTRAL SCREW CO.	2530 CRESCENT DR.	BROADVIEW, IL 60153
97464	INDUSTRIAL RETAINING RING CO.	57 CORDIER ST.	IRVINGTON, NJ 07111

Fig. & Index No.	Tektronix Part No.	Serial/Model No. Eff	Dscont	Qty	1 2 3 4 5					Name & Description	Mfr Code	Mfr Part Number
-1	337-1399-02			1						SHLD,ELECTRICAL:SIDE WITH INSULATOR	80009	337-1399-02
-2	337-1399-00			1						SHLD,ELECTRICAL:SIDE	80009	337-1399-00
-3	366-1606-00			1						KNOB:GRY,DSPL,0.125 ID,1.5 OD,0.75H	80009	366-1606-00
	213-0153-00			2						. SETSCREW:5-40 X 0.125 INCH,HEX SOC STL	74445	OBD
	348-0031-00	XB010750		1						GROMMET,PLASTIC:0.156 INCH DIA	80009	348-0031-00
-4	366-1402-27			1						PUSHBUTTON:"INT"	80009	366-1402-27
	366-1557-19			1						PUSHBUTTON:"DB"	80009	366-1557-19
-5	366-1422-01			1						KNOB:LATCH	80009	366-1422-01
										(ATTACHING PARTS)		
-6	214-1840-00			1						PIN,KNOB SECRG:	80009	214-1840-00
										- - - * - - -		
-7	129-0064-02			1						POST,BDG,ELEC:WHITE,5-WAY,MINIATURE	58474	DF21WTC
										(ATTACHING PARTS)		
-8	210-0457-00			1						NUT,PLAIN,EXT W:6-32 X 0.312 INCH,STL	83385	OBD
-9	210-0202-00			1						TERMINAL,LUG:SE #6	78189	2104-06-00-2520N
										- - - * - - -		
-10	129-0064-00			1						POST,BDG,ELEC:CHARCOAL,5-WAY MINIATURE	58474	BINP BB10167G13T
										(ATTACHING PARTS)		
-11	210-0457-00			1						NUT,PLAIN,EXT W:6-32 X 0.312 INCH,STL	83385	OBD
-12	358-0181-00			1						INSULATOR,BSHG:CHARCOAL	58474	BB10166G13BX
										- - - * - - -		
-13	129-0064-01			1						POST,BDG,ELEC:RED,5-WAY MINIATURE	58474	BB10167G2BX
										(ATTACHING PARTS)		
-14	210-0457-00			1						NUT,PLAIN,EXT W:6-32 X 0.312 INCH,STL	83385	OBD
-15	358-0181-01			1						INSULATOR,BSHG:RED	58474	BB1066G2
										- - - * - - -		
-16	131-1652-00			1						CON,RCPT,ELEC:1 FEM,1 MALE CONTACT	0000A	RA0302
										(ATTACHING PARTS)		
	210-0255-00			1						TERMINAL,LUG:0.391" ID INT TOOTH	80009	210-0255-00
										- - - * - - -		
-17	426-0681-00			2						FR,PUSH BUTTON:GRAY PLASTIC	80009	426-0681-00
-18	333-1976-00			1						PANEL,FRONT:	80009	333-1976-00
	333-1976-01			1						PANEL,FRONT:OPTION 2	80009	333-1976-01
										(ATTACHING PARTS)		
-19	210-0405-00			2						NUT,PLAIN,HEX.:2-56 X 0.188 INCH,BRS	73743	2X12157-402
-20	210-0259-00			1						TERMINAL,LUG:0.099"ID INT TOOTH,SE	80009	210-0259-00
-21	210-0001-00			1						WASHER,LOCK:INTL,0.092 ID X 0.18"OD,STL	78189	1202-00-00-0541C
-22	211-0034-00			2						SCREW,MACHINE:2-56 X 0.500 INCH,PNH,STL	77250	OBD
										- - - * - - -		
-23	331-0314-00			1						WINDOUT,READOUT:	80009	331-0314-00
-24	426-0916-00			1						FRAME,RDOUT WDO:	80009	426-0916-00
-25	386-3149-00			1						SUBPANEL,FRONT:PLASTIC	80009	386-3149-00
										(ATTACHING PARTS)		
-26	213-0227-00			2						SCR,TPG,THD FOR:6-32 X 0.50 100 DEG,FLH ST		OBD
-27	213-0229-00			2						SCR,TPG,THD FOR:6-20 X 0.375"100 DEG,FLH STL	83385	OBD
										- - - * - - -		
-28	214-1513-01			1						LCH,PLUG-IN RET:	80009	214-1513-01
										(ATTACHING PARTS)		
-29	213-0254-00			1						SCR,TPG,THD CTG:2-56X0.25"100 DEG,FLH STL	45722	OBD
										- - - * - - -		
-30	337-2130-00			1						SHIELD,ELEC:SUBL PL REAR	80009	337-2130-00
-31	-----			1						CKT BOARD ASSY:DISPLAY (SEE A2 EPL)		
-32	131-0608-00			17						. CONTACT,ELEC:0.365 INCH LONG	22526	47357
-33	384-1129-00			1						EXTENSION SHAFT:5.607 INCH LONG	80009	384-1129-00
	672-0478-00			1						CKT BOARD ASSY:W/CAM SW	80009	672-0478-00
	672-0479-00			1						CKT BOARD ASSY:W/CAM SW	80009	672-0479-00
										(ATTACHING PARTS)		
-34	213-0146-00			4						SCR,TPG,THD FOR:6-20 X 0.313 INCH,PNH STL	83385	OBD
										- - - * - - -		
	263-1106-00			1						. ACTR,ASSY,CAM S:W/TIME/CM	80009	263-1106-00
										(ATTACHING PARTS)		
-35	211-0116-00			8						. SCR,ASSEM WSHR:4-40 X 0.312 INCH,PNH BRS	83385	OBD
										- - - * - - -		

Mechanical Parts List—DM 502

Fig. & Index No.	Tektronix Part No.	Serial/Model No. Eff	No. Dscnt	Qty						Name & Description	Mfr Code	Mfr Part Number	
					1	2	3	4	5			Mfr	Part Number
-36	200-1743-00			1	COVER,CAM SW:6.200"DA,18 32 ELEM (ATTACHING PARTS)	80009	200-1743-00	
-37	211-0008-00			8	SCREW,MACHINE:4-40 X 0.25 INCH,PNH STL	83385	OB	
-38	210-0004-00			8	WASHER,LOCK:INTL,0.12 ID X 0.26"OD,STL	78189	1204-00-00-0541C	
					-	-	-	-	-	* - - -			
-39	210-0406-00			4	NUT,PLAIN,HEX.:4-40 X 0.188 INCH,BRS	73743	2X12161-402	
-40	407-1199-00			1	BRACKET,COVER:	80009	407-1199-00	
-41	376-0008-00			1	CPLG,SHAFT,RGD:	80009	376-0008-00	
	213-0005-00			2	SETSCREW:8-32 X 1.25 INCH,HEX SOC STL	74445	OB	
-42	210-0406-00			4	NUT,PLAIN,HEX.:4-40 X 0.188 INCH,BRS	73743	2X12161-402	
-43	214-1139-03			1	SPRING,FLAT:RED COLORED	80009	214-1139-03	
	214-1139-02			1	SPRING,FLAT:GREEN COLORED	80009	214-1139-02	
-44	214-1127-00			2	ROLLER,DETENT:0.125 DIA X 0.125 INCH L	80009	214-1127-00	
-45	401-0081-02			1	BEARING,CAM SW:FRONT (ATTACHING PARTS)	80009	401-0081-02	
-46	354-0391-00			1	RING,RETAINING:0.395"FREE ID X 0.025" STL	97464	3100-43-CD	
					-	-	-	-	-	* - - -			
-47	105-0642-00			1	ACTUATOR,CAM SW:TIME/CM,REAR	80009	105-0642-00	
-48	210-0406-00			4	NUT,PLAIN,HEX.:4-40 X 0.188 INCH,BRS	73743	2X12161-402	
-49	401-0115-00			1	BEARING,CAM SW:CENTER	80009	401-0115-00	
-50	210-0406-00			4	NUT,PLAIN,HEX.:4-40 X 0.188 INCH,BRS	73743	2X12161-402	
-51	214-1139-03			1	SPRING,FLAT:RED COLORED	80009	214-1139-03	
	214-1139-02			1	SPRING,FLAT:GREEN COLORED	80009	214-1139-02	
-52	214-1127-00			2	ROLLER,DETENT:0.125 DIA X 0.125 INCH L	80009	214-1127-00	
-53	401-0081-02			1	BEARING,CAM SW:FRONT (ATTACHING PARTS)	80009	401-0081-02	
-54	354-0391-00			1	RING,RETAINING:0.395"FREE ID X 0.025" STL	97464	3100-43-CD	
					-	-	-	-	-	* - - -			
-55	105-0641-00			1	ACTUATOR,CAM SW:TIME/CM,FRONT	80009	105-0641-00	
-56	-----			1	CKT BOARD ASSY:MAIN(SEE A1 EPL)			
-57	131-0604-00			45	CONTACT,ELEC:0.025 SQ X 0.365 INCH LONG	80009	131-0604-00	
-58	131-0608-00			26	CONTACT,ELEC:0.365 INCH LONG	22526	47357	
-59	-----			1	TRANSFORMER:(SEE T410 EPL)			
-60	407-1640-00			1	BRACKET,XFMR:0.826 WD,2.375" L,1.781 H (ATTACHING PARTS)	80009	407-1640-00	
-61	211-0507-00			2	SCREW,MACHINE:6-32 X 0.312 INCH,PNH STL	83385	OB	
-62	210-0457-00			2	NUT,PLAIN,EXT W:6-32 X 0.312 INCH,STL	83385	OB	
					-	-	-	-	-	* - - -			
-63	260-1208-00			1	SWITCH,PUSH:DPDT	71590	2KAB010000-359	
-64	361-0573-00			2	SPACER,SLEEVE:	80009	361-0573-00	
-65	344-0154-00			4	CLIP,ELECTRICAL:FOR 0.25 INCH DIA FUSE	80009	344-0154-00	
-66	136-0514-00			2	SOCKET,PLUG-IN:MICROCIRCUIT,8 CONTACT	82647	C930802	
-67	136-0269-02			3	SOCKET,PLUG-IN:14 CONTACT,LOW CLEARANCE	01295	C931402	
-68	136-0260-02			5	SOCKET,PLUG-IN:16 CONTACT,LOW CLEARANCE	01295	C931602	
-69	260-1332-00			1	SWITCH,PUSH:	80009	260-1332-00	
-70	361-0385-00			2	SPACER,PB SW:0.164 INCH LONG	80009	361-0385-00	
	131-0993-02			1	LINK,TERM.CONNE:2 WIRE RED	00779	1-530153-0	
	131-0993-09			1	LINK,TERM.CONNE:2 WIRE WHITE	00779	530153-1	
-71	214-0579-00			2	TERM.,TEST PT:0.40 INCH LONG	80009	214-0579-00	
-72	131-0566-00			1	LINK,TERM.CONNE:0.086 DIA X 2.375 INCH L	0000C	L-2007-1	
	214-1291-00			1	HEAT SINK,ELEC:XSTR,0.72 OD X 0.375"H	05820	207-AB	
	131-0993-02			1	**LINK,TERM.CONNE:2 WIRE RED	00779	1-530153-0	
	131-0993-09			1	**LINK,TERM.CONNE:2 WIRE WHITE	00779	530153-1	
-73	426-0724-04			1	FR	SECT,	PLUG-IN:	BOTTOM			80009	426-0724-04	
-74	214-1061-00			1	SPRING,	GROUND:	FLAT				80009	214-1061-00	
-75	426-0725-05			1	FR	SECT,	PLUG-IN:	TOP			80009	426-0725-05	
-76	352-0169-00			1	CONN	BODY,PL,EL:	2 WIRE	BLACK			80009	352-0169-00	
-77	352-0161-01			1	CONN	BODY,PL,EL:	3 WIRE	BROWN			80009	352-0161-01	
-78	352-0165-02			2	HOLDER,	TERM.CON:	7 WIRE,	RED			80009	352-0165-02	
-79	352-0168-09			2	HOLDER,	TERM.CON:	10 WIRE,	WHITE			80009	352-0168-09	
-80	131-0707-00			39	CONTACT,	ELEC:0.48"L,	22-26	AWG	WIRE		22526	47439	
-81	175-0830-00			FT	WIRE,	ELECTRICAL:	7 WIRE	RIBBON			08261	TEK-175-0830-00	
-82	175-0833-00			FT	WIRE,	ELECTRICAL:	10 WIRE	RIBBON			23499	TEK-175-0833-00	

Mechanical Parts List—DM 502

Fig. & Index No.	Tektronix Part No.	Serial/Model No. Eff Dscont	Qty						Name & Description	Mfr	
				1	2	3	4	5		Code	Mfr Part Number
	175-0825-00		FT						WIRE,ELECTRICAL:2 WIRE RIBBON	23499	TEK-175-0825-00
	175-0826-00		FT						WIRE,ELECTRICAL:3 WIRE RIBBON	08261	TEK-175-0826-00
ACCESSORIES											
	070-1726-00		1						MANUAL,TECH:INSTRUCTION (NOT SHOWN)	80009	070-1726-00
	010-6430-00		1						PROBE:TEMPERATURE (NOT SHOWN)	80009	010-6430-00
	003-0120-00		1						TEST LEADS: (PAIR) (NOT SHOWN)	80009	003-0120-00
REPACKAGING											
	065-0151-00		1						CARTON ASSEMBLY: (NOT SHOWN)	80009	065-0151-00

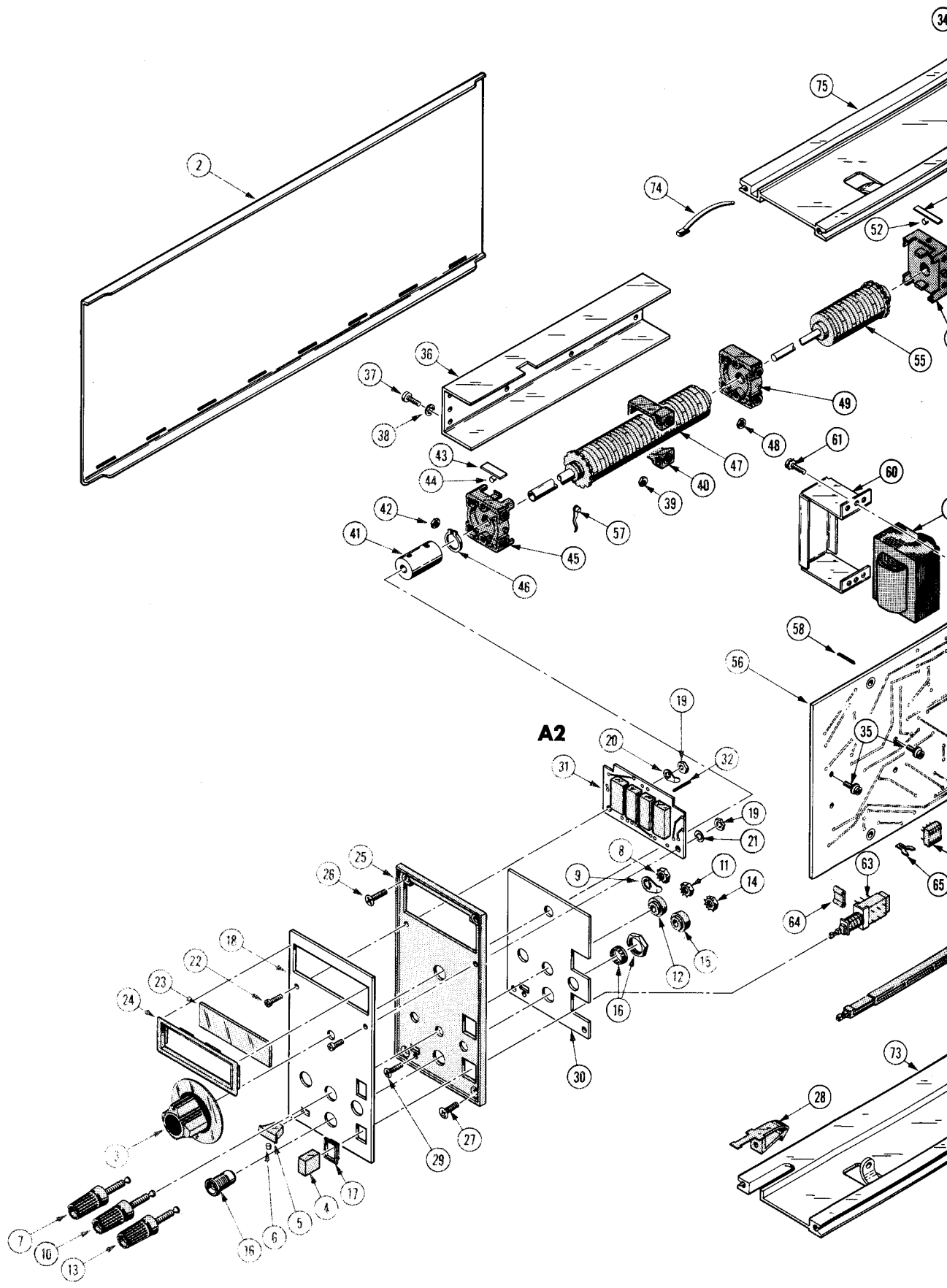
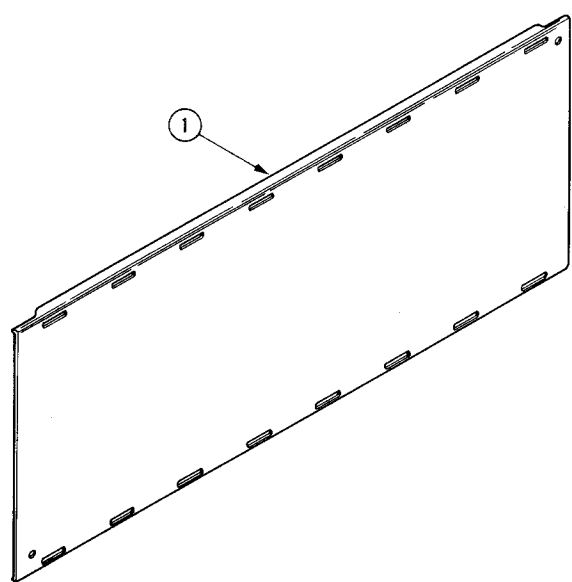
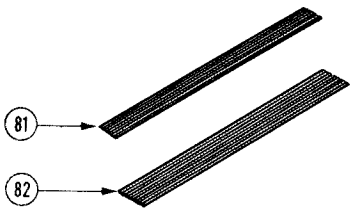
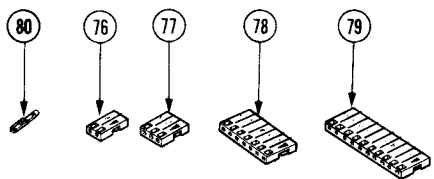
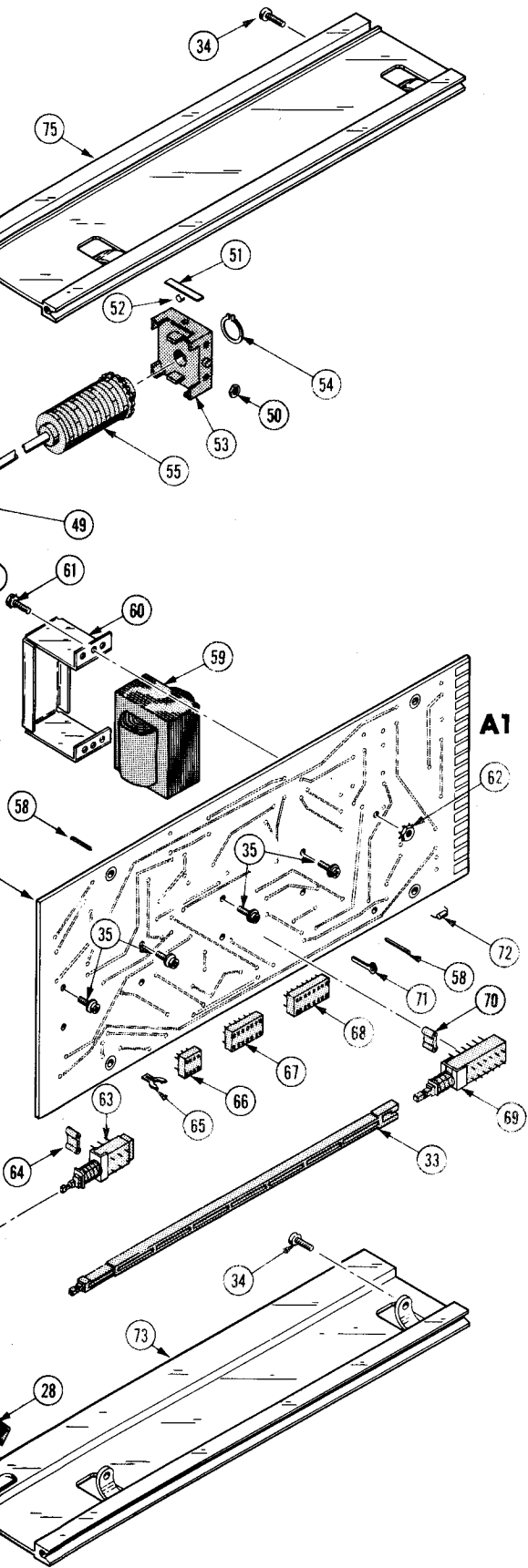



FIG. 1 EXPLODED



MANUAL CHANGE INFORMATION

At Tektronix, we continually strive to keep up with latest electronic developments by adding circuit and component improvements to our instruments as soon as they are developed and tested.

Sometimes, due to printing and shipping requirements, we can't get these changes immediately into printed manuals. Hence, your manual may contain new change information on following pages.

A single change may affect several sections. Sections of the manual are often printed at different times, so some of the information on the change pages may already be in your manual. Since the change information sheets are carried in the manual until ALL changes are permanently entered, some duplication may occur. If no such change pages appear in this section, your manual is correct as printed.



MANUAL CHANGE INFORMATION

PRODUCT DM 502
070-1726-00

CHANGE REFERENCE C4/175
 DATE 1-27-75

CHANGE:	DESCRIPTION
---------	-------------

NOTE: Changes are circled below.

REAR INTERFACE CONNECTOR ASSIGNMENTS

Remarks	Maximum Recommended Loads	Active Level	Output or Input	Pin B		Pin A	Output or Input	Active Level	Maximum Recommended Leads	Remarks
			HI Input	28		28	LO Input			
	*	H	Decimal Out	27		27	Common			Floating Common Use as common for all data outputs.
	*	H	MSD Out	26		26	3rd SD Out	H	*	
	*	H	2nd SD Out	25		25	LSD Out	H	*	
Chassis Gnd			Temp Gnd	24		24	Temp Out			10 mV/°. Use ≥10 kΩ load
				23		23				
				22		22				
	*	H	BCD Out 2	21		21				
	*	H	BCD Out 8	20		20	BCD Out 4	H	*	
	*	L	Transfer	19		19	BCD Out 1	H	*	
				18	Barrier	18				
				17	Slot	17				
				16		16				
Multiplexed	*	L	One Out	15		15				
	*	H+	Polarity Out	14		14				
			25 VAC Winding	13		13	25 VAC Winding			
			+33.5 V filtered DC	12		12	+33.5 V filtered DC			
			Collector lead of PNP Series-Pass	11		11	Base lead of PNP Series-Pass			
			Transformer shield	10		10	Emitter lead of PNP Series-Pass			
			33.5 V common	9		9	33.5 V common			
			-33.5 V filtered DC	8		8	-33.5 V filtered DC			



TEKTRONIX[®]

committed to
technical excellence

MANUAL CHANGE INFORMATION

PRODUCT DM 502 &
DM 502 Option 2

CHANGE REFERENCE M23,279/REV
DATE 2-11-75

CHANGE:	DESCRIPTION
---------	-------------

070-1726-00

EFF SN B020000-up

ELECTRICAL PARTS LIST AND SCHEMATIC CHANGES

CHANGE TO:

A1	670-3495-01	CKT BOARD ASSY:MAIN
A1	670-3694-01	CKT BOARD ASSY:MAIN OPTION 2
C197	290-0536-00	CAP.,FXD,ELCTLT:10 μ F,20%,25V
C198	290-0527-00	CAP.,FXD,ELCTLT:15 μ F,20%,20V
C199	290-0535-00	CAP.,FXD,ELCTLT:33 μ F,20%,10V
R198	321-0202-00	RES.,FXD,FILM:1.24K OHM,1%,0.125W
R199	321-0202-00	RES.,FXD,FILM:1.24K OHM,1%,0.125W

REMOVE:

C429	283-0279-00	CAP.,FXD,CER DI:0.001 μ F,20%,3KV
------	-------------	---------------------------------------

ADD:

C110	283-0279-00	CAP.,FXD,CER DI:0.001 μ F,20%,3KV
R200	321-0202-00	RES.,FXD,FILM:1.24K OHM,1%,0.125W

DIAGRAM  ATTENUATORS & CONVERSION CIRCUITS - Partial

