



**PLEASE CHECK FOR CHANGE INFORMATION  
AT THE REAR OF THIS MANUAL.**

**1502B METALLIC  
TIME DOMAIN  
REFLECTOMETER**

**OPERATOR MANUAL**

**Tektronix, Inc.**  
P.O. Box 500  
Beaverton, OR 97077

070-6266-01  
Product Group 22

First Printing OCT 1987  
REV JUL 1988

Copyright © 1987 and 1988 Tektronix, Inc. All rights reserved.  
Contents of this publication may not be reproduced in any form  
without the written permission of Tektronix, Inc.

Products of Tektronix, Inc. and its subsidiaries are covered by  
U.S. and foreign patents and/or pending patents.

TEKTRONIX, TEK, and  are registered trademarks of Tek-  
tronix, Inc.

Printed in U.S.A. Specification and price change privileges are  
reserved.

---

**Certificate of the Manufacturer/Importer**

We hereby certify that TDR Model 1502B complies with the RF Interference Suppression requirements of Amtsbl.-Vfg 1046/1984. The German Postal Service was notified that the equipment is being marketed. The German Postal Service has the right to re-test the series and to verify that it complies.

TEKTRONIX

**Bescheinigung des Herstellers/Importeurs**

Hiermit wird bescheinigt, daß das TDR Modell 1502B in Übereinstimmung mit den Bestimmungen der Amtsblatt-Verfügung 1046/1984 funkentstört ist. Der Deutschen Bundespost wurde das Inverkehrbringen dieses Gerätes angezeigt und die Berechtigung zur Überprüfung der Serie auf Einhalten der Bestimmungen eingeraäumt.

TEKTRONIX

**NOTICE to the user/operator:**

The German Postal Service requires that this equipment, when used in a test setup, may only be operated if the requirements of Postal Regulation, Vfg. 1046/1984, Par. 2, Sect. 1.7.1 are complied with.

**HINWEIS für den Benutzer/Betreiber:**

Dies Gerät darf in Meßaufbauten nur betrieben werden, wenn die Voraussetzungen des Par. 2, Ziff. 1.7.1 der Vfg. 1046/1984 eingehalten werden.

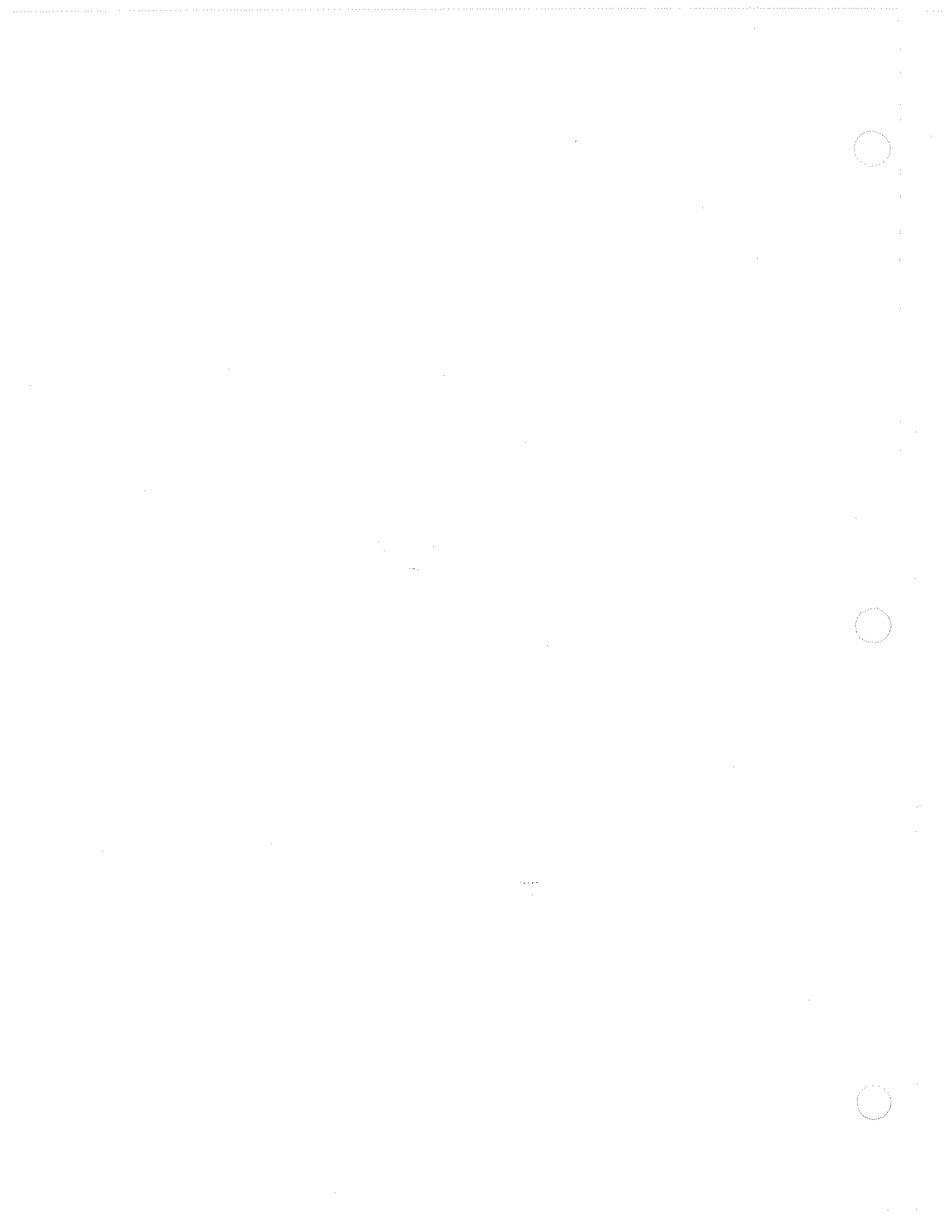

# TABLE OF CONTENTS

<b>SECTION 1 SAFETY AND INSTALLATION</b>	<b>Page</b>
Operator Safety Summary .....	1-1
Installation .....	1-3
Repacking for Shipment .....	1-3
 <b>SECTION 2 OPERATOR SECTION</b>	
<b>General Information</b> .....	2-1
Handling Information .....	2-1
Powering the 1502B .....	2-1
Care of the Optional Battery Pack .....	2-2
Battery Charging Information .....	2-2
Low Battery .....	2-3
Low Temperature Operation .....	2-3
<b>Operator Instructions</b> .....	2-4
Preparing to Use the 1502B .....	2-4
Front Panel Controls .....	2-4
Menu Selections .....	2-8
<b>Test Preparations</b> .....	2-11
Importance of $V_p$ .....	2-11
Impedance of Various Cables .....	2-11
V of Various Dielectrics .....	2-11
Finding an Unknown $V_p$ .....	2-12
<b>Cable Test Procedures</b> .....	2-13
Distance to the Fault .....	2-13
Reflection Coefficient Measurement .....	2-15
Return Loss Measurement .....	2-16
Ohms-at-Cursor .....	2-17
Using VIEW INPUT .....	2-18
How to STORE the Waveform .....	2-18
Using VIEW STORE .....	2-18
Using VIEW DIFF .....	2-19
Using Vertical and Horizontal SET REF .....	2-22
HORZ SET REF .....	2-22
VERT SET REF .....	2-24
Vertical Compensation .....	2-25
Additional Features .....	2-26
Max Hold .....	2-26
Pulse On/Off .....	2-27
Single Sweep .....	2-28

## Table of Contents (con't)

<b>SECTION 2 OPERATOR SECTION (con't)</b>	<b>Page</b>
<b>Operator Tutorial</b> .....	2-29
What is the Tektronix 1502B? .....	2-29
How Does it Do It? .....	2-29
YOU, the Operator .....	2-29
The MENU Screens .....	2-29
Getting Started .....	2-30
Waveform Up Close .....	2-32
A Longer Cable .....	2-33
Ohms-at-Cursor .....	2-34
Noise .....	2-36
Set Ref ( $\Delta$ Mode) .....	2-37
HORZ SET REF .....	2-37
VERT SET REF .....	2-39
VIEW INPUT .....	2-41
STORE and VIEW STORE .....	2-42
VIEW DIFF .....	2-43
Menu Accessed Functions .....	2-44
Max Hold .....	2-44
Pulse On/Off .....	2-46
Single Sweep .....	2-47
<b>TDR Questions and Answers</b> .....	2-48
<b>Glossary</b> .....	2-50
<b>Troubleshooting</b> .....	2-55
Troubleshooting Chart .....	2-56
 <b>SECTION 3 SPECIFICATION</b>	
<b>General Information</b> .....	3-1
Product Description .....	3-1
Optional Battery Pack .....	3-1
Options .....	3-1
Standards and Documents .....	3-1
Change and History Information .....	3-1
<b>Specification</b> .....	3-1
Electrical Characteristics .....	3-2
Environmental Characteristics .....	3-5
Physical Characteristics .....	3-6

## Table of Contents (con't)

<b>SECTION 3 SPECIFICATION (con't)</b>	<b>Page</b>
<b>Operator Check Procedure</b> .....	3-7
Equipment Required .....	3-7
Getting Ready .....	3-7
POWER On .....	3-7
Set Up .....	3-7
Horizontal Scale (Timebase) Check .....	3-8
Vertical Position (Offset) Check .....	3-9
Noise Check .....	3-10
Offset/Gain Check .....	3-11
Sampling Efficiency Check .....	3-11
Aberrations Check .....	3-12
Risetime Check .....	3-13
Jitter Check .....	3-14
Conclusions .....	3-15
 <b>SECTION 4 ACCESSORIES AND OPTIONS</b>	
<b>Accessories</b> .....	4-1
Standard Accessories .....	4-1
Optional Accessories .....	4-2
<b>Options</b> .....	4-3
Battery Pack .....	4-3
Battery Pack Removal .....	4-3
YT-1 Chart Recorder .....	4-3
Instructions for Use .....	4-3
Paper Replacement .....	4-3
Metric Default .....	4-4
Power Cord Options .....	4-4





# OPERATOR SAFETY SUMMARY

The general safety information in this part of the summary is for both operating and servicing personnel. Specific warnings and cautions will be found throughout the manual where they apply, but may not appear in this summary.

## Terms

### In This Manual:

**CAUTION** statements identify conditions or practices which could result in damage to the equipment or other property.

**WARNING** statements identify conditions or practices which could result in personal injury or loss of life.

### As Marked on Equipment:

**CAUTION** indicates a personal injury hazard not immediately accessible as one reads the marking, or a hazard to property including the equipment itself.

**DANGER** indicates a personal injury hazard immediately accessible as one reads the marking.

## Symbols

### In This Manual:



This symbol indicates, where applicable, cautionary or other information is to be found.

### As Marked on Equipment:



**DANGER** High Voltage



**ATTENTION** refer to manual.



Protective ground (earth) terminal.

## Power Source

This product is intended to operate from a power source that will not apply more than 250 volts RMS between the supply conductors or between the supply conductor and ground. A protective ground connection by way of the grounding conductor in the power cord is essential for safe operation.

## Grounding the Product

This product is grounded through the grounding conductor of the power cord. To avoid electric shock, plug the power cord into a properly wired receptacle before connecting to the product input or output terminals. A protective ground connection by way of the grounding conductor in the power cord is essential for safe operation.

## Danger Arising From Loss of Ground

Upon loss of the protective-ground connection, all accessible conductive parts (including knobs and controls that appear to be insulating) can render an electric shock.

## Use the Proper Power Cord

Use only the power cord and connector specified for your product. Do not use instrument without a rated AC line cord.

The standard power cord (161-0228-00) is rated for outdoor use. *All other optional power cords are rated for indoor use only.*

Use only a power cord that is in good condition.

Refer cord and connector changes to qualified service personnel.

### **Use the Proper Fuse**

To avoid fire hazard, use only the fuse of the correct type.

Refer fuse replacement to qualified service personnel.

### **Do Not Operate in Explosive Atmospheres**

To avoid explosion, do not operate this product in an explosive atmosphere unless it has been specifically certified for such operation.

### **Do Not Remove Covers or Panels**

To avoid personal injury, do not remove the product covers or panels. Do not operate the product without the covers and panels properly installed.

# INSTALLATION AND REPACKING

## Unpacking and Initial Inspection

Before unpacking the 1502B from its shipping container or carton, inspect for signs of external damage. If the carton is damaged, notify the carrier. The shipping carton contains the basic instrument and its standard accessories. Refer to the replaceable parts list in the Service Manual for a complete listing.

If the contents of the shipping container are incomplete, if there is mechanical damage or defect, or if the instrument does not meet operational check requirements, contact your local Tektronix Field Office or representative. If the shipping container is damaged, notify the carrier as well as Tektronix.

The instrument was inspected both mechanically and electrically before shipment. It should be free of mechanical damage and meet or exceed all electrical specifications. Procedures to check operational performance are in the Operator Check Procedure in the *Specification Section*. This check should satisfy the requirements for most receiving or incoming inspections. The electrical Performance Check Procedure is part of the *Service Manual*.

## Power Source and Power Requirements

The 1502B is intended to be operated from a power source that will not apply more than 250V RMS between the supply conductors or between either supply conductor and ground. A protective ground connection by way of the grounding conductor in the power cord is essential for safe operation.

The AC power connector is a three-way polarized plug with the ground (earth) lead connected directly to the instrument frame to provide electrical shock protection. If the unit is connected to any other power source, the unit frame must be connected to earth ground.

Power and voltage requirements are printed on the back panel. The 1502B can be operated from either 115 VAC or 230 VAC nominal line voltage, at 45 to 440 Hz, a 12 VDC supply, or a batter pack.

Further information on the 1502B power requirements can be found in the *Operator Safety Summary* in this section and in the *Operator* section.

## Repacking for Shipment

When the 1502B is to be shipped to a Tektronix Service Center for service or repair, attach a tag showing the name and address of the owner, name of the individual at your firm that can be contacted, complete serial number, and a description of the service required. If the original packaging is unfit for use or is not available, repackage the instrument as follows:

1. Obtain a carton of corrugated cardboard having inside dimensions that are at least six inches greater than the equipment dimensions to allow for cushioning. The test strength of the shipping carton should be 275 pounds (102.5 kg). Refer to the following table for test strength requirements.

SHIPPING CARTON TEST STRENGTH	
Gross Weight (lb)	Carton Test Strength (lb)
0-10	200
10-30	275
30-120	375
120-140	500
140-160	600

2. Install the front cover on the 1502B, and surround the instrument with polyethylene sheeting to protect the finish.
3. Cushion the instrument on all sides with packing material or urethane foam between the carton and the sides of the instrument.
4. Seal with shipping tape or an industrial stapler.

If you have any questions, contact your local Tektronix field office or representative.

### CAUTION

*The Option 03 battery pack should be removed from the instrument before shipping. If necessary to ship the battery, it should be wrapped and secured separately before being packed with the instrument.*



# OPERATOR SECTION

## This Section

- **General Information**

  - Handling Information*

  - Powering the 1502B*

  - Care of the Optional Battery Pack*

  - Battery Charging Information*

  - Low Battery*

  - Low Temperature Operation*

- **Operator Instructions**
- **Operator Tutorial**
- **Operator Maintenance**
- **Questions and Answers**
- **Glossary**

## General Information

### Handling Information

The 1502B front panel is protected by a watertight cover in which standard accessories are stored. Secure the front cover by snapping the side latches outward. If the instrument is inadvertently left on, installing the front cover will turn off the POWER switch automatically.

The carrying handle rotates 325° and serves as a stand when positioned beneath the instrument.

Inside the case at the back of the instrument is a moisture absorbing canister containing silica gel. In extremely wet environments it may be necessary to periodically remove and dry the canister. This procedure is explained in the *1502B Service Manual*.

The 1502B can be stored in temperatures ranging from  $-62^{\circ}\text{C}$  to  $+85^{\circ}\text{C}$ . However, if the temperature is below  $-40^{\circ}\text{C}$  or exceeds  $+55^{\circ}\text{C}$ , the battery pack should be removed and stored. Battery storage temperature should be between  $-40^{\circ}\text{C}$  to  $+55^{\circ}\text{C}$ .

### Powering the 1502B

In the field, the 1502B can be powered using the optional internal battery pack. For AC operation, check the rear panel for proper voltage setting. The voltage selector can be seen through the window of the protective cap. If the setting differs from the voltage available, it can be easily changed. Simply remove the protective cap on the rear panel and select the proper voltage range with a screwdriver.

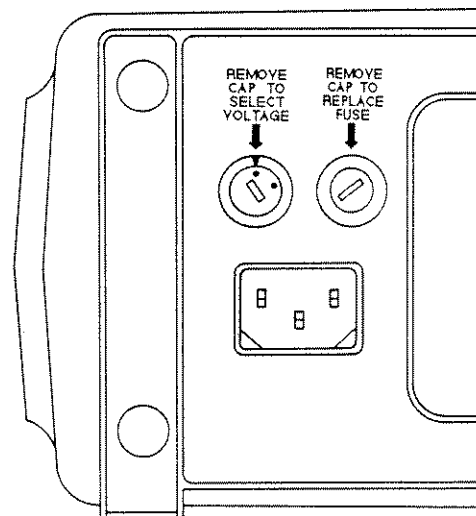

The 1502B is intended to be operated from a power source that will not apply more than 250V RMS between the supply conductors or between either supply conductor and ground. A protective ground connection by way of the grounding conductor in the power cord is essential for safe operation.

The AC power connector is a three-way polarized plug with the ground (earth) lead connected directly to the instrument frame to provide electrical shock protection. If the unit is connected to any other power source, the unit frame must be connected to an earth ground. See more information in the *Safety and Installation* section.

**CAUTION**

*If you change the voltage selector, you must change the line fuse to the appropriate value as listed near the fuse holder, and in the table below.*

FUSE RATING	VOLTAGE RATING	
250 V	NOMINAL RANGE	
0.3A T	115 VAC	90-132 VAC
0.15A T	230 VAC	180-250 VAC

### Care of the Optional Battery Pack

**CAUTION**

*Read these instructions concerning the care of the optional battery pack. They contain instructions that reflect on your safety and the performance of the instrument.*

The 1502B can be powered by an optional rechargeable nickel-cadmium battery pack that is easily accessible from the back of the instrument without removing the case. When AC power is applied, the battery pack is charged at a continuous rate of approximately 150 mA.

The battery pack will operate the 1502B for a minimum of five continuous hours (including 20 chart recordings).

### Battery Charging Information

The battery pack will charge fully in 16 hours when the instrument is connected, via the power cord, to an AC power source with the instrument turned off. The instrument may be turned on and operated while the batteries are charging, but this will increase the charging time. For longest battery life, a full charge is preferred over a partial charge.

For maximum capacity, the batteries should be charged within a temperature range of +20°C to +25°C. However, the batteries can be charged within a temperature range of 0°C to +40°C, and operated in temperatures ranging from -15°C to +55°C.

**CAUTION**

*Do not charge battery pack below 0° C or above 45° C. Do not discharge battery pack below -20° C or above 65° C. Do not use this instrument outside these parameters or the batteries may emit explosive gas (hydrogen). If removing the battery pack during or after exposure to these conditions, turn the instrument off and remove the AC power cord. Move the instrument to an ignition-free area before removing the battery pack.*

If the instrument is operated beyond the previously stated limits, turn off the instrument and either disconnect the AC power or remove the battery pack.

The battery pack should be stored within a temperature range of  $-40^{\circ}\text{C}$  to  $+55^{\circ}\text{C}$ . However, the self-discharge rate will increase as the temperature increases.

If the instrument is shipped, the battery pack should be removed. If the instrument is stored with the battery pack installed, the battery pack should be charged every thirty days, or the battery pack removed. A fully charged battery pack will lose about 50% of its capacity in three to four months if stored between  $+20^{\circ}\text{C}$  and  $+25^{\circ}\text{C}$ .

The batteries can be damaged by reverse charging. This can occur when an individual cell becomes discharged before the others, and current from the other cells flow in a reverse direction through the discharged cell. Reverse charging may develop because of individual cell aging, partial charging of the battery pack or if a single cell has been replaced rather than the entire pack.

### Low Battery

If the battery is low, it will be indicated on the LCD (*bat/low*). If this is the case, protective circuitry will shut down the 1502B within minutes. Either replace the battery pack, switch to AC power, or work fast. If the instrument is equipped with a chart recorder, using the recorder will further reduce the battery level, or the added load may shut down the instrument.

Protection circuits in the charger prevent deep discharge of the batteries during instrument operation. The circuits automatically shut down the instrument whenever battery voltage falls below approximately 10 V. If shutdown occurs, the batteries should be fully recharged before further use.

*NOTE: Turn the POWER switch off after instrument shutdown to prevent continued discharge of the batteries.*

*NOTE: Under low AC line voltage conditions, the AC fuse ratings may be exceeded if the battery is fully discharged and a chart recording is being made. Allow the battery to charge for about one hour before attempting to make a chart recording, or use AC only.*

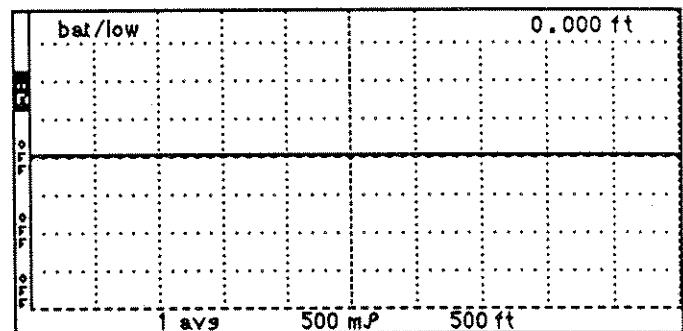

### Low Temperature Operation

When operating the 1502B in an environment below  $+10^{\circ}\text{C}$ ., a heater will activate. The element is built into the LCD module, and will heat the display to permit normal operations. Depending on the surrounding temperature, it may take up to 15 minutes to completely warm the crystals in the LCD. Once warmed, the display will operate normally.

# OPERATOR INSTRUCTIONS

## Preparing to Use the 1502B

Check the power requirements, remove the front cover, and you are ready to test cables. The following pages explain the front panel controls.

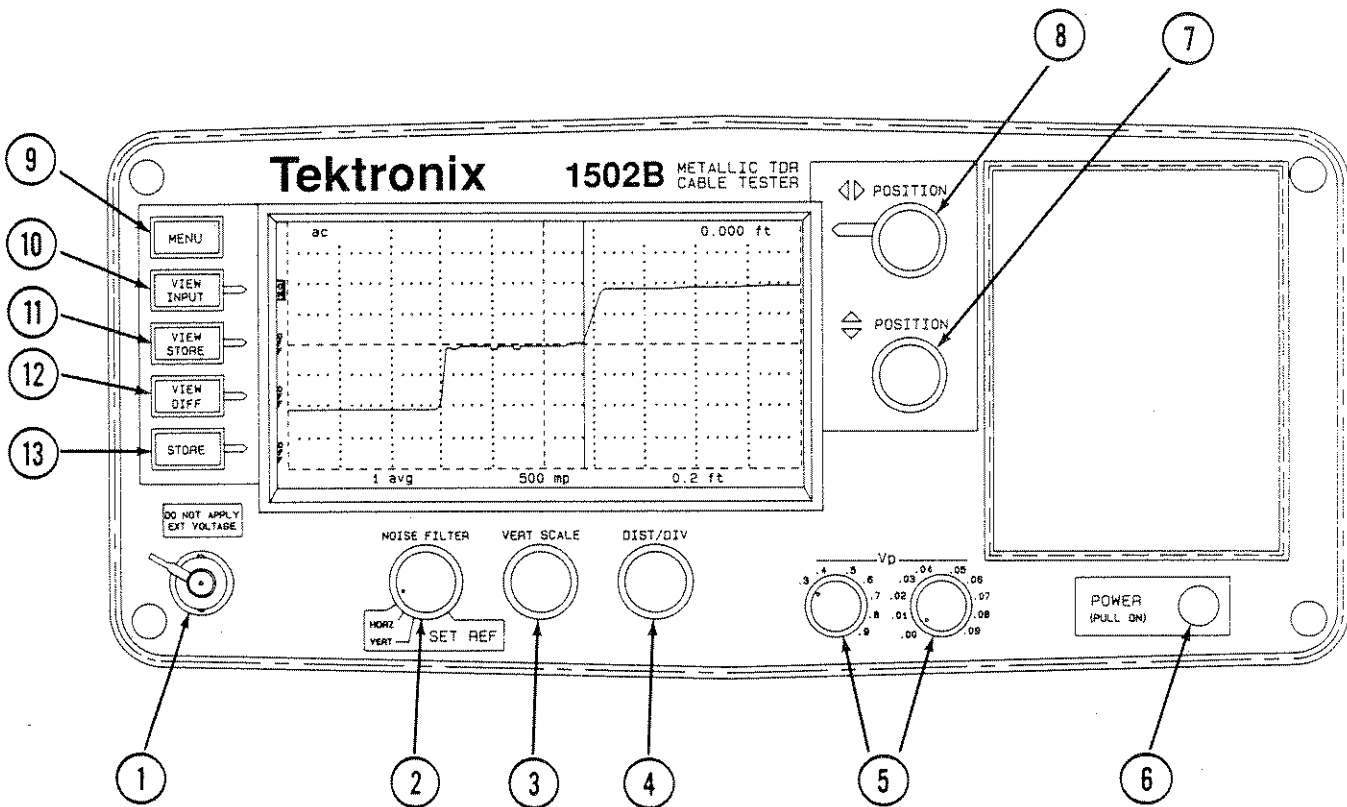

1502B Front Panel Controls



## Front Panel Controls

The 1502B uses a step-type test signal for its measurements. For simplicity it is referred to in this section as a pulse.

### 1 CABLE

A female BNC connector for attaching a cable to the 1502B for testing.

### 2 NOISE FILTER

If the displayed waveform is noisy, the apparent noise can be reduced by using noise averaging. Averaging settings are between 1 and 128. The time for averaging is directly proportional to the averaging setting chosen. A 128 setting may take the instrument up to 35 seconds to acquire and display. The first two positions on the NOISE FILTER control are used for setting the vertical and horizontal reference points. Selected value or function is displayed above the control on the LCD.

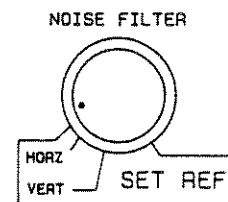

### 3 VERT SCALE

Sets the vertical sensitivity displayed in mp per division or vertical gain in dB. Although the instrument defaults to millirho, the operator may choose which mode from the menu ("Set Up Menu"). Selected value is displayed above the control on the LCD.

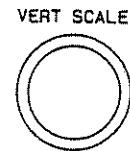

### 4 DIST/DIV

Determines the number of feet (or metres) per division across the display. Minimum setting is 0.1 ft/DIV (*.025 metres*); maximum setting is 200 ft/DIV (*50 metres*). Selected value is displayed above the control on the LCD. A standard instrument defaults to ft/DIV. A metric instrument (Option 5) defaults to m/DIV, but either metric or standard can be changed temporarily from the menu. The default can be changed by changing an internal jumper. (*See Service Manual*).

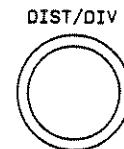

**5 V<sub>p</sub> (Velocity of Propagation)**

These controls are set according to the propagation velocity factor of the cable being tested. For example, solid polyethylene commonly has a V<sub>p</sub> of 0.66. Solid polytetrafluoroethylene (Teflon®) is approximately 0.70. Air is 0.99. The controls are decaded: the left control is the first digit; the right control the second digit. For example, with a V<sub>p</sub> of 0.30, the first knob would be set to .3, the second knob to .00.

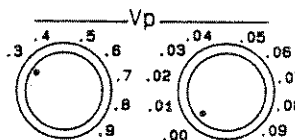

**6 POWER**

Pull for power ON, push in for power OFF. When the front cover is installed, this switch is automatically pushed OFF.

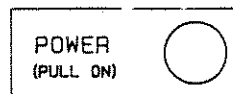

**7 POSITION**

This is a continuously rotating control that positions the displayed waveform up or down the LCD.

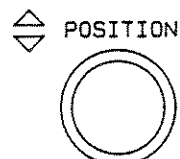

**8 POSITION**

This is a continuously rotating control that moves a vertical cursor completely across the LCD graticule. In addition, the waveform is also moved when the cursor reaches the extreme right or left side of the display. A readout is displayed (7-digit maximum) in the upper right hand corner of the LCD, displaying the distance from the front panel BNC to the cursor.

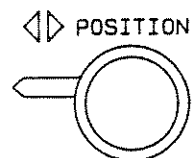

Another feature of the cursor is the "ohms-at-cursor" readout. This menu selected feature calculates the impedance of the cable at the cursor. See "Ohms-at-Cursor" instructions in this section for the limitations of this feature.

**9 MENU**

Provides access to the menu, and also selects items chosen from the menu.



**10 VIEW INPUT**

When pushed momentarily, this button toggles the display of the waveform acquired at the CABLE connector. This function is useful to stop displaying the current waveform to avoid confusion when looking at a stored waveform. Function defaults to ON when instrument is powered up.



**11 VIEW STORE**

When pushed momentarily, this button toggles the display of the stored waveform.

**12 VIEW DIFF**

When pushed momentarily, this button toggles the display of the CURRENT waveform minus the STORED waveform.

**13 STORE**

When pushed momentarily, the waveform currently displayed will be stored in the instrument memory. If a waveform is already stored, pushing **STORE** momentarily will erase it. The settings of the stored waveform are available from the first level menu under "View Stored Waveform Settings".

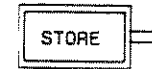

## MENU SELECTIONS

There are several "layers" of menu as explained below.

### Main Menu

**MAIN MENU** is entered by pushing the **MENU** button on the front panel.

1. **Return to Normal Operation** puts the instrument into Normal Operation mode.
2. **Help with Instrument Controls** explains the operation of each control. When a control or switch is adjusted or pushed, a brief explanation appears on the LCD.
3. **Cable Information** has three menu choices:
  - Help with Cables** gives a brief explanation of cable parameters.
  - Velocity of Propagation Values** displays a table of common dielectrics and their  $V_p$  values. These are nominal values. The manufacturers listed specifications should be used whenever possible.
  - Impedance Values** displays impedances for common cables. In some cases these values have been rounded off. Manufacturers specifications should be checked for precise values.
  - Finding unknown  $V_p$  values** describes a procedure for finding an unknown  $V_p$ .
4. **Setup Menu** controls the manner in which the instrument obtains and displays its test results.
  - Acquisition Control Menu** has three choices.
    - Max Hold is:** on or off. Set up by pushing **MENU**, then activated by pushing **STORE**. In this mode, waveforms are accumulated on the display. **MAX HOLD** can be deactivated by pushing **STORE** or the mode exited by using the **Setup** menu.
    - Pulse is:** on or off. Turns the pulse generator off so the 1502B does not send out pulses.
    - Single Sweep is:** on or off. This function is much like a still camera: it will acquire one waveform and hold it.
  - Ohms-at-Cursor is:** on or off. When activated, the impedance at the point of the cursor is displayed beneath the distance window on the display.
  - Vertical Scale is:** offers a choice as to how the vertical gain of the instrument is displayed. You may choose decibels or millirho. When powered down, the instrument will default to millirho when powered back up.
  - Distance/Div is:** offers a choice as to how the horizontal scale of the instrument displayed. You may choose from feet per division, or metres per division. When powered up, the instrument will default to feet per division unless specified by an internal jumper. Instructions on changing this default to metres are contained in the *Service Manual*.
  - Light is:** on or off. This control turns the electroluminescent backlight behind the LCD off and on.

5. **Diagnostics Menu** lists an extensive selection of diagnostics to test the operation of the instrument.

#### **Service Diagnostics Menu**

**Sampling Efficiency Diagnostic** displays a continuous efficiency diagnostic of the sampling circuits.

**Noise Diagnostic** measures the internal RMS noise levels of the instrument.

**Offset/Gain Diagnostic** reports out of tolerance steps in the programmable gain stage. This can help a service technician quickly isolate the cause of waveform distortion problems.

**RAM/ROM Diagnostics Menu** performs tests on the RAM (Random Access Memory) and the ROM (Read Only Memory).

**Timebase is:** Normal - Auto Correction, or Diagnostic - No Correction. When in *Normal*, the instrument compensates for variations in temperature and voltage. This condition may not be desirable while calibrating the instrument. While in *Diagnostic - No Correction*, the circuits will not correct for these variations.

**Front Panel Diagnostic** aids in testing the front panel.

#### **LCD Diagnostics Menu**

**LCD Alignment Diagnostic** generates a dot pattern of every other pixel on the LCD. These pixels can be alternated to test the LCD.

**Response Time Diagnostic** generates alternate squares of dark and light, reversing their order. This tests the response time of the LCD, and can give an indication as to the effectiveness of the LCD heater in a cold environment.

**LCD Driver Test Diagnostic** generates a moving vertical bar pattern across the LCD.

**Contrast Adjust** allows you to adjust the contrast of the LCD. It generates an alternating four pixel pattern. The nominal contrast is set internally. When in *Contrast Adjust* mode, VERT SCALE is used as the contrast adjustment control. This value ranges from 0 to 255 units, and is used by the processor to evaluate and correct circuit variations caused by temperature changes in the environment.

**Chart Diagnostics Menu** offers various tests for the optional YT-1 chart recorder.

**LCD chart** allows adjusting the number of dots per segment and the number of prints (strikes) per segment.

**Head Alignment Chart** generates a pattern to allow mechanical alignment of the optional YT-1 chart recorder.

6. **View Stored Waveform Settings** displays the instrument settings for the stored waveform.
7. **Option Port Menu** contains three items. Two items allow configuration of the option port for communicating with devices other than the optional YT-1 chart recorder, and one item that tests the option port.

**Option Port Diagnostic** creates a repeating pattern of signals at the option port to allow service technicians to verify that all the signals are present and working correctly.

**Set Option Port Timing** allows adjustment of the data rate used to communicate with external devices. The timing rate between bytes can be set from about 0.05 to 12.8 milliseconds.

**Option Port Debugging is:** OFF - Quiet, or ON - Verbose, chooses how detailed the error message reporting will be when communicating with an external device.

It is possible to connect the instrument to a computer through a parallel interface with a unique software driver. Since different computers vary widely in processing speed, the instrument must be able to adapt to differing data rates while communicating with those computers. With user-developed software drivers, the ability to obtain detailed error messages during the development can be very useful. For more information, contact your Tektronix Customer Service Representatives. They have information describing the option port hardware and software protocol and custom development methods available.

## Test Preparations

### The Importance of $V_p$ (Velocity of Propagation)

$V_p$  is the speed of a signal down the cable given as a percentage of the speed of the signal in free space. It is sometimes expressed as a whole number (66), or a percentage (66%). On the 1502B it is the percentage expressed as a decimal number, e.g. 66% is .66. If you do not know the velocity of propagation, you can get a general idea from the following table, or use the *Help with Cables* section of the "Cable Information" menu. You can also find the  $V_p$  with the procedure that follows using a cable sample.

*NOTE: If you do not know the  $V_p$  of your cable, it will not prevent you from finding a fault in your cable. However, if  $V_p$  is set wrong, distance readings will be effected.*

### $V_p$ of Various Dielectric Types

Dielectric	Probable $V_p$
Jelly Filled	.64
Polyethylene (PIC, PE, or SPE)	.66
PTFE (Teflon®) or TFE	.70
Pulp Insulation	.72
Foam or Cellular PE (FPE)	.78
Semi-solid PE (SSPE)	.84
Air (Helical spacers)	.98

### Finding an Unknown $V_p$

1. Obtain a known length of cable of the exact type you wish to test. Attach the cable to the **CABLE** connector on the front panel.

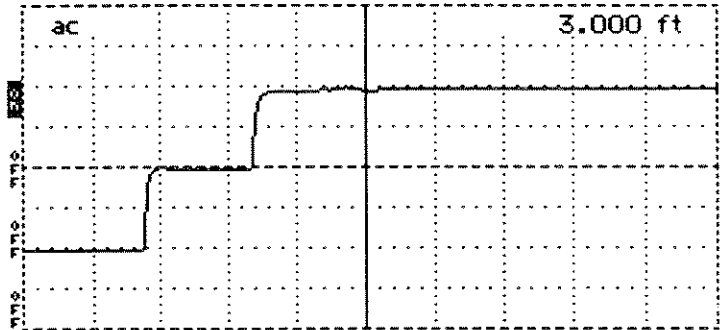

$V_p$  of .30 when it should have been .66 for 3 foot cable.

2. Pull **POWER** on.

3. Turn **DIST/DIV** to appropriate setting. For example, if trying to find the  $V_p$  of a 3 foot cable, turn **DIST/DIV** to 1 ft/DIV. Turn **POSITION** until the distance reading is the same as the known cable length.

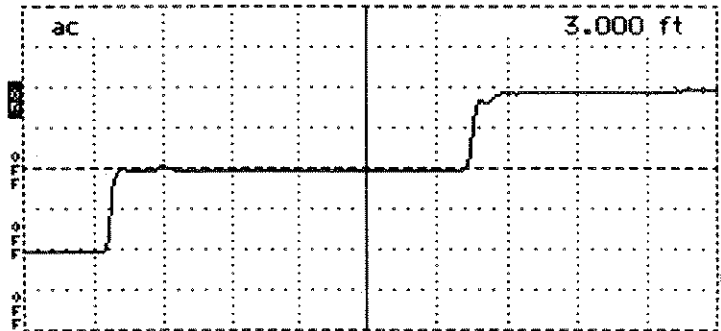

$V_p$  of .99 when it should have been .66 for 3 foot cable.

4. Turn the  $V_p$  controls until the cursor is resting on the rising portion of the reflected pulse. The  $V_p$  controls of the instrument are now set to the  $V_p$  of the cable.

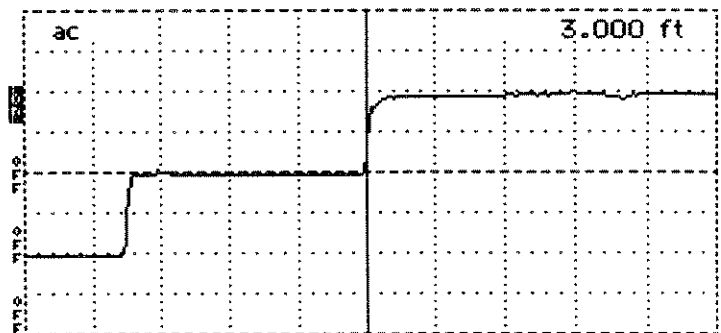

$V_p$  set correctly at .66 for a 3 foot cable.



## Cable Test Procedures

### Distance to the Fault

Be sure to read the previous paragraphs on  $V_p$ .

1. Set the 1502B front panel:

POWER	On
CABLE	Cable to BNC
NOISE FILTER	1 avg
VERT SCALE	500 mp
DIST/DIV	(see below)
$V_p$	(per cable)

2. If you know approximately how long the cable is, set **DIST/DIV** appropriately. e.g. A 20 foot cable would occupy 4 divisions on the LCD if 5 ft/DIV were used. The entire cable would be displayed.

If the cable length is unknown, set **DIST/DIV** to 200 ft/DIV, and continue to decrease the **DIST/DIV** setting until the reflected pulse is visible. Depending on cable length and the amount of pulse energy absorbed by the cable, it may be necessary to increase the **VERT SCALE** to provide more gain to see the reflected pulse.

3. Once the entire cable is displayed you can tell if there is an open or a short. Essentially, a drop in the pulse is a short, and a rise in the pulse is an open. Less catastrophic faults can be seen as hills and valleys in the waveform. Bends and kinks, frays, water, interweaving, all have distinctive signatures.

4. To find the distance to the fault or end of the cable, turn  $\Phi$  **POSITION** until the cursor rests on the leading edge of the rising or falling reflected pulse. Read the distance in the distance window in the upper right corner of the display.

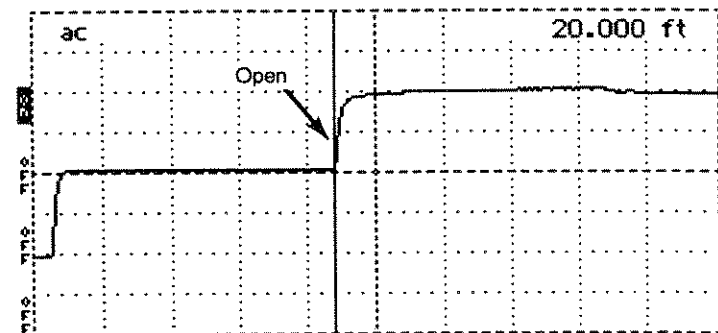
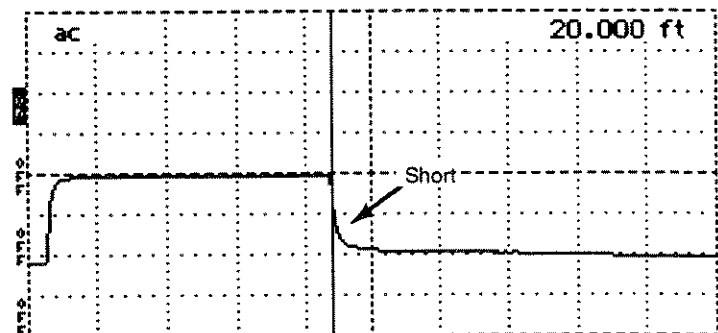
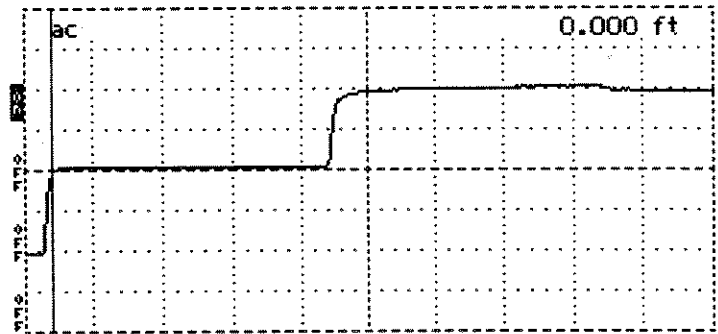

A more thorough inspection may be required. This example will use a longer cable.

5. When inspecting a 452 foot cable, a setting of 50 ft/DIV would allow a relatively fast inspection. If needed, turn up **VERT SCALE** to increase the gain. The higher the gain, the smaller the faults that can be detected. If noise increases, increase the **NOISE FILTER** setting.

6. Change **DIST/DIV** to 20 ft/DIV. The entire cable can be inspected in detail on the LCD. Turn the **POSITION** control so the cursor travels to the far right side of the LCD. Keep turning, and the cable will be "dragged" across the display in either direction.

A "rise" or "fall" is a signature of an impedance mismatch, (fault). A dramatic rise in the pulse indicates an open. A dramatic lowering of the pulse indicates a short. Variations, such as inductive and capacitive effects on the cable, will appear as bumps and dips on the waveform. Capacitive faults will appear as a lowering of the pulse (water). Inductive faults will appear as a rising of the pulse (kinks). Whenever an abnormality is found, set the cursor at beginning of the fault and read the distance to the fault on the distance window of the LCD. (See *Reflection Coefficient Measurement*).

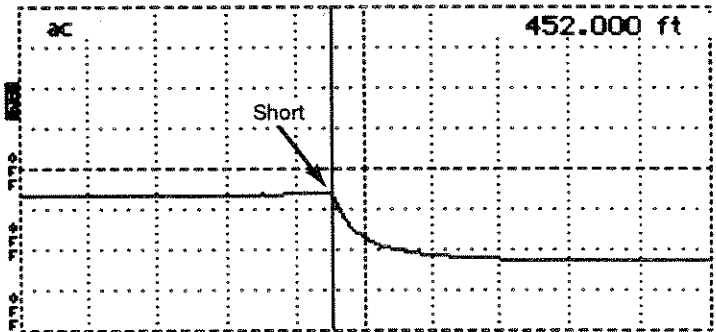
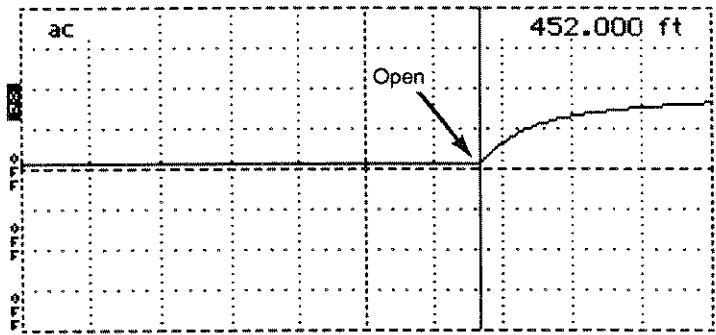

### Reflection Coefficient Measurement

The reflection coefficient is a measure of the impedance change at a point in the cable. It is the ratio of the signal reflected back from a point divided by the signal going into that point. It is designated by the greek letter  $\rho$  and is written in this manual as "Rho". The 1502B measures reflection coefficient in millirho (rho times one thousand).

To measure a reflection, adjust VERT SCALE to make the reflection one division high. Read the reflection coefficient directly off the display above the VERT SCALE control. For reflections that are greater than 500 mp/DIV, adjust VERT SCALE for a reflection that is two division high and multiply the display VERT SCALE reading by two.

In a ideal transmission system with no changes in impedance, there will be no reflections, so rho is equal to zero. A good cable that is terminated in its characteristic impedance is close to ideal and will appear as a flat line on the 1502B display.

Small impedance changes, like those from a connector might have reflections from ten to one hundred millirho ( $\rho = .01$  to  $.1$ ). If rho is positive, it indicates an impedance higher than the impedance of the cable before the reflection. It will show as an upward bump or shift on the 1502B trace. If rho is negative, it indicates an impedance lower than the impedance of the cable before the reflection. It will show as a downward bump or shift on the 1502B trace.

If the cable has an open or short, all of the energy sent out by the 1502B will be reflected. This is a reflection coefficient of  $\rho = 1$  or +1000 mp for the open and -1000 mp for a short.

Long cables have enough loss to affect the size of reflections. This loss will usually be apparent as an upward ramping of the trace along the length of the cable. In some cases the reflection coefficient measurement can be corrected for this loss. See *VERT SET REF* in this manual for details on making this correction.

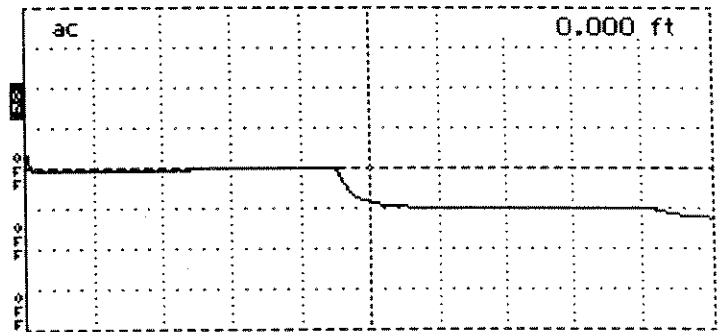

### Return Loss Measurement

Return loss is another way of measuring impedance changes in a cable. Mathematically return loss is related to rho by the formula:

$$\text{return loss in dB} = -20 * \log \text{ base ten of the absolute value of rho}$$

The 1502B can be made to display in dB instead of mp/DIV through MENU.

Press **MENU**, and select "Setup Menu". Press **MENU** and select Vertical Scale is: Millirho. Press **MENU** and the selection will change to Vertical Scale is: Decibels.

Press **MENU** to exit from the Setup Menu and press it again to return to Normal Operation.

To measure return loss with the 1502B, adjust the reflected pulse to be two divisions high and read the dB return loss directly off the LCD display. The incident pulse is set to be two divisions high at zero dB automatically when the instrument is turned on.

A large return loss means that most of the pulse energy was "lost" instead of being "returned" as a reflection. The lost energy may have been sent down the cable or absorbed by a terminator or load on the cable. A terminator matched to the cable would absorb most of the pulse so its return loss would be large. An open or short would reflect or "return" all of the energy so its return loss would be zero.

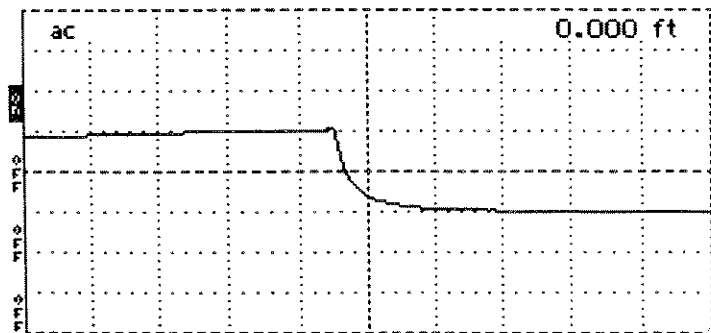

### Ohms-at-Cursor

The 1502B can compute and display what impedance mismatch would cause a reflection as high (or low) as the point at the cursor. This measurement is useful for evaluating the first impedance mismatch (first reflection) or small impedance changes along the cable (such as connectors and splices).

This function can be selected in the "Setup Menu". Once it is enable the impedance value will be displayed under the distance to the cursor.

The accuracy of the difference in impedance between two points near each other on the cable is much better than the absolute accuracy of any single point measurement. For example a cable may vary from  $51.3\Omega$  to  $58.4\Omega$  across a connector, the  $7.1\Omega$  difference is accurate to about 2%. The  $51.3\Omega$  measurement is only specified to be accurate to 10%.

The series resistance of the cable to the point at the cursor affects the accuracy of the impedance measured directly. In a cable with no large impedance changes, the series resistance is added to the reading. For example the near end of a long  $50\Omega$  coaxial cable may read  $51.5\Omega$  and read  $57.5\Omega$  several hundred feet along the cable. The  $6\Omega$  difference is due to the series resistance of the cable, not to a change in the impedance of the cable.

Another limitation to the ohms at the cursor function is that energy is lost going both directions through a fault. This will cause readings of points farther down the cable to be less accurate than points nearer the instrument.

In general it is not wise to try to make absolute measurements past faults, since the larger the fault the less accurate those measurements will be. Although they do not appear as faults, resistive pads (often used to match cable impedances) also affect measurements this way.

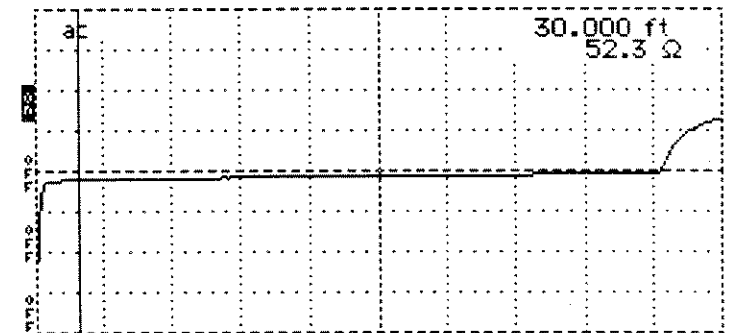
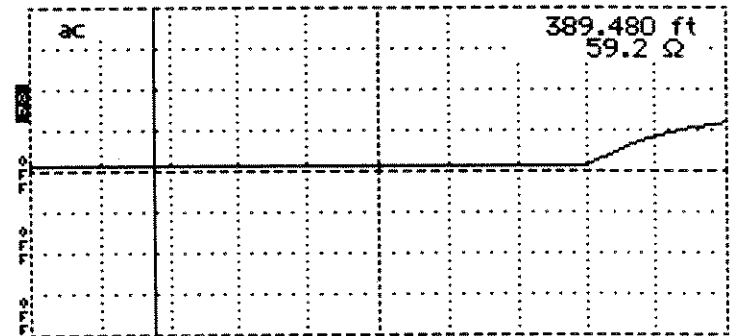
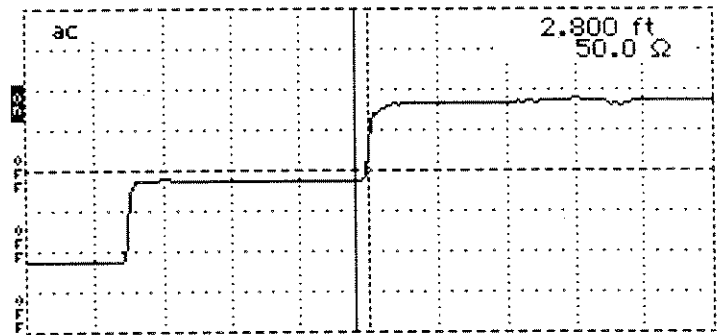

### Using VIEW INPUT

When pushed on, the **VIEW INPUT** button displays on the LCD the input at the front panel **CABLE** connector. When this button is turned off, and no other buttons are pushed, the display will not have a waveform on it. **VIEW INPUT** is on when the instrument is powered up.

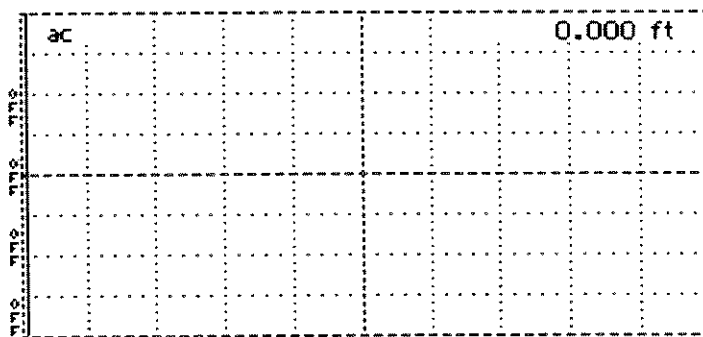

### How to STORE the Waveform

When pushed on, the **STORE** button puts the current waveform displayed into memory. If already stored, **STORE** will erase the stored waveform.

The front panel controls settings and the menu accessed settings are also stored. They are accessed under "View Stored Waveform Settings" in the first level in the menu. Press **MENU**.

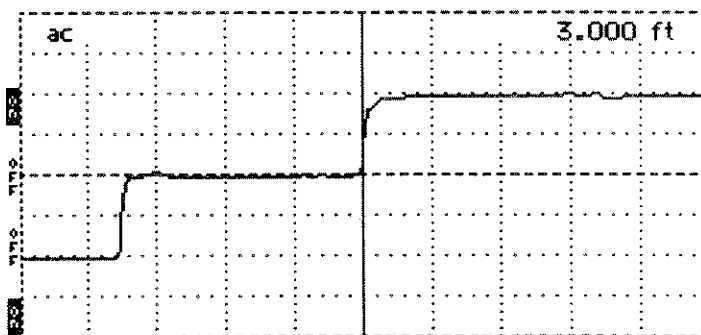

### Using VIEW STORE

The **VIEW STORE** button, when pushed on, displays on the LCD the waveform stored in the memory as a dotted line. If no waveform is in the memory, an error message will appear.

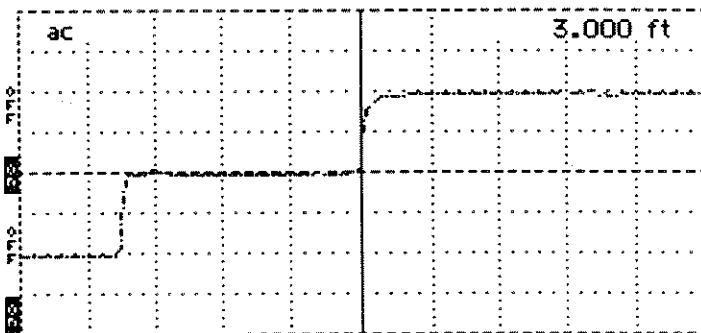

## Using VIEW DIFF

When pushed on, the **VIEW DIFF** button displays on the LCD the difference between the current input and the stored waveform as a dotted line. If no waveform has been stored, an error message will appear. The "difference" waveform is made by subtracting each point in the stored waveform from each point in the current input waveform.

*NOTE: If the two waveforms are identical, i.e. if **STORE** is pushed, and **VIEW DIFF** is immediately selected, the waveforms would be identical, and the difference would be zero. A straight line would be displayed.*

The **VIEW DIFF** waveform will move up and down with the current input as you move the **POSITION** control. Any of the waveforms may be turned on and off independently. You may wish to turn off some waveforms if the display becomes too "busy" or confusing.

*NOTE: Since the stored waveform is not effected by changes in the instrument controls, care should be taken or the results could be misleading.*

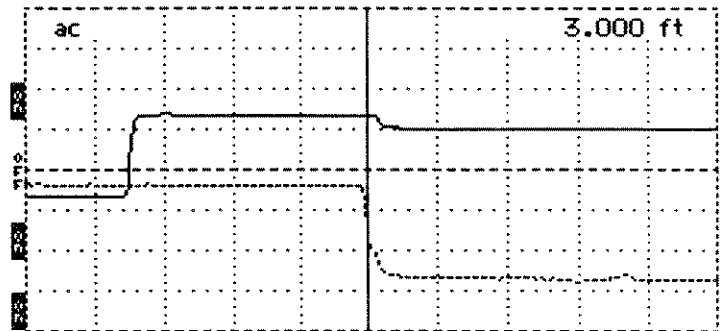

One method to minimize the overlapping of the waveforms in VIEW DIFF is:

1. Move the waveform to be stored into the top half of the display. Push **STORE** to capture the waveform. Remember, once it is stored this waveform cannot be moved on the display.

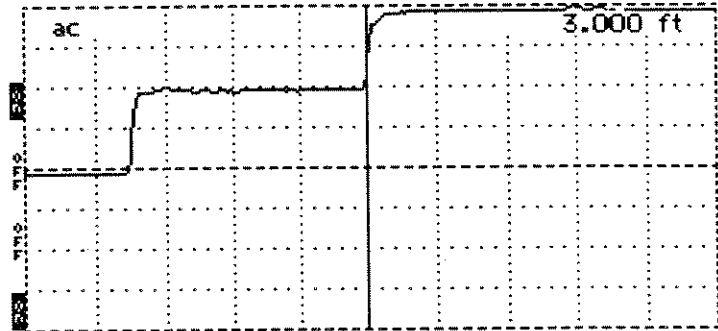

2. Move the current input waveform (the one you want to compare with the stored waveform) to the center of the display. Push **VIEW STORE** and the stored waveform will appear above the current input waveform.

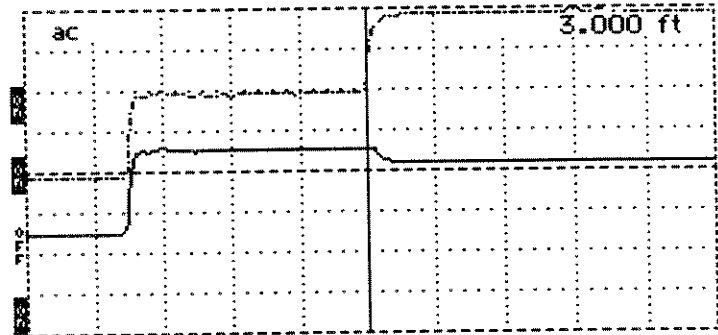

3. Push **VIEW DIFF** and the difference waveform will appear below the current input waveform.

Notice the **VIEW INPUT** waveform is solid, **VIEW DIFF** is dotted, and **VIEW STORE** is dot-dash.

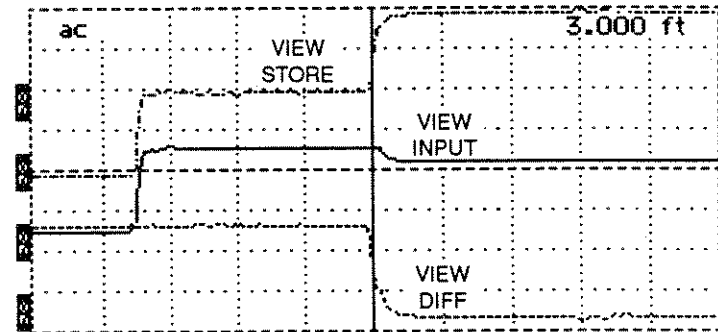



There are many situations where the VIEW DIFF function can be useful. One common situation is to store the waveform of a suspect cable, repair the cable, then compare the two waveforms after the repair. During repairs the VIEW INPUT, VIEW DIFF and VIEW STORE waveforms can be used to judge the effectiveness of the repairs. The optional YT-1 chart recorder can be used to make a chart of the three waveforms to document the repair.

Another valuable use for the VIEW DIFF function is for verifying cable integrity before and after servicing or periodic maintenance which requires moving or disconnecting the cable.

The VIEW DIFF function is useful when you want to see any changes in the cable. In some systems there may be several reflections coming back from each branch of the network. It may become necessary to disconnect branch lines from the cable under test to determine whether a waveform represents a physical fault or is simply an echo from one of the branches. The STORE and VIEW DIFF functions allow you to see and compare the network with and without branches.

Two important cautions should be observed when using the VIEW DIFF function. If you change either VERT SCALE or DIST/DIV you will no longer be comparing features that are the same distance apart or of the same magnitude on the display. It is possible to save a feature (e.g., a connector or tap) at one distance down the cable and compare it to a similar feature at a different distance by moving the  $\leftarrow$  POSITION and  $\rightarrow$  POSITION controls. When this is done great care should be taken to make sure the vertical and horizontal scales are identical for the two waveforms being compared. If either the stored or current waveform is clipped at the top or bottom of the display the difference waveform will be effected.

## Using Vertical and Horizontal SET REF

### HORZ SET REF ( $\Delta$ Mode)

HORZ SET REF mode allows you to offset the distance reading. For example, a lead-in cable to a switching network is 3 feet long, and it's desirable to start the measurement after the end of the lead-in cable. HORZ SET REF makes it simple.

1. Turn **NOISE FILTER** control to HORZ SET REF. The noise reading on the LCD will read "set  $\Delta$ ".

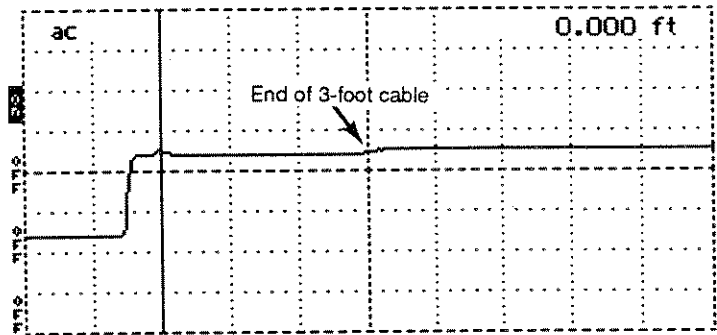

2. Turn  $\Phi$  **POSITION** to set the cursor where you want to start your distance reading. This is the "new" zero reference point. For a 3 foot lead-in cable the cursor would be set at 3 feet.

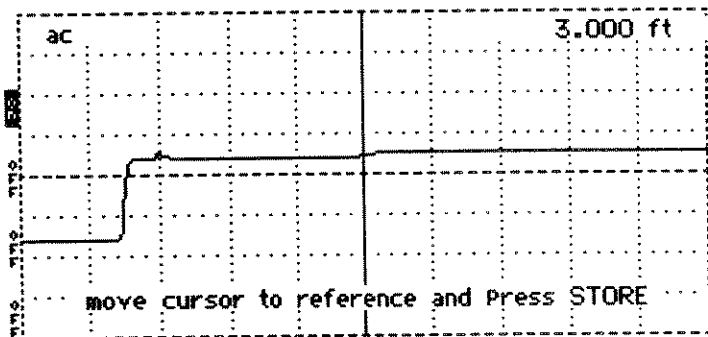

3. Push **STORE**.

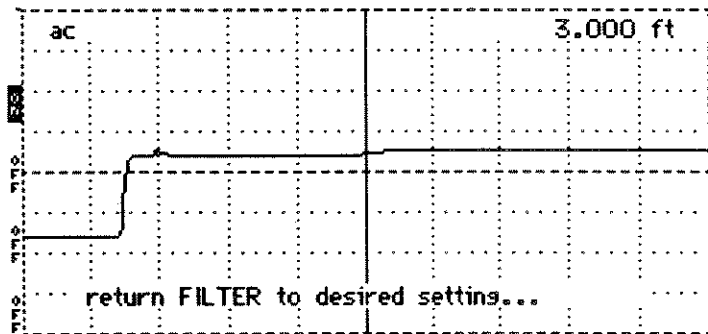

4. Turn **NOISE FILTER** control to 1 avg. The instrument is now in HORZ SET REF, or *DELTA* mode. The distance window reads 0.000 ft $\Delta$ . As the cursor is scrolled down the cable, the distance reading will be from the *new* zero reference point.

*NOTE:  $V_p$  changes will affect where the reference is set on the cable. Set  $V_p$ , then Set  $\Delta$  to the desired location.*

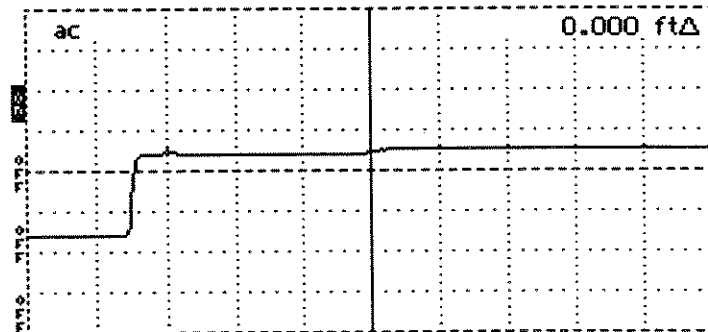

5. To exit HORZ SET REF, use the following procedure:

a. Turn NOISE FILTER control to HORZ SET REF.

b. Turn DIST/DIV to .1 ft/DIV. (If distance reading is extremely high, you may want to use a higher setting initially, then turn to .1 ft/DIV for the next adjustment).

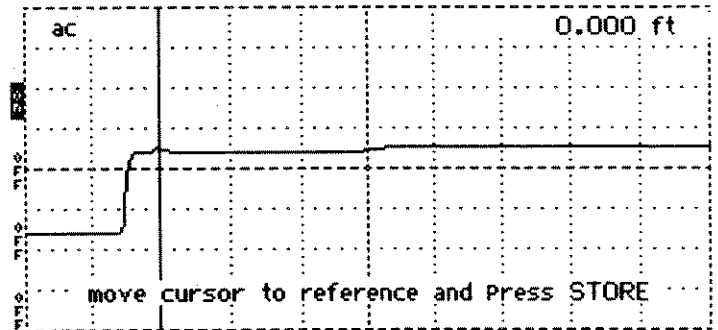

c. Turn  $\Phi$  POSITION until the distance window reads 0.000 ft.

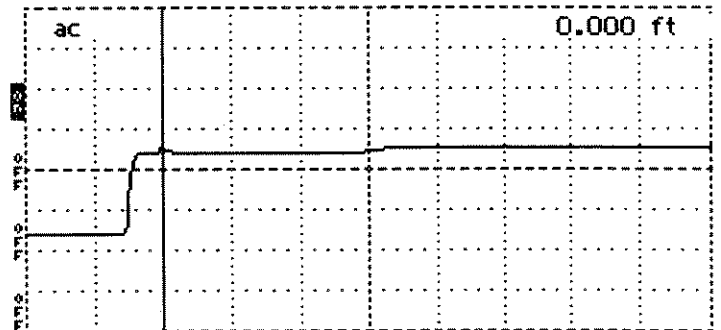

d. Push STORE.

e. Turn NOISE FILTER to desired setting.

### VERT SET REF

**VERT SET REF** works similar to **HORZ SET REF**, except that it sets a reference for gain (pulse height) instead of distance. This feature allows overriding the automatic pulse height circuit and adjusting the pulse height manually.

1. Turn **NOISE FILTER** fully counterclockwise. "Set Ref" will appear in the noise averaging window on the LCD. Adjust the incident pulse to the desired height (for example, four divisions). It may be necessary to adjust  $\phi$  POSITION.
2. Push **STORE**. Return **NOISE FILTER** to desired setting. Note that **VERT SCALE** now reads 500 mp/DIV.

#### IMPORTANT

*The millirho vertical scale will not be in calibration after arbitrarily adjusting the pulse height.*

The millirho scale is the reciprocal of the number of divisions the pulse is set. For example, 1 pulse divided by 4 divisions equals 0.25mp equals 250mp/DIV.

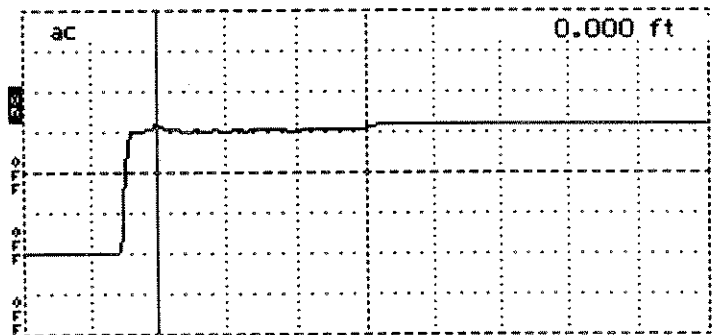
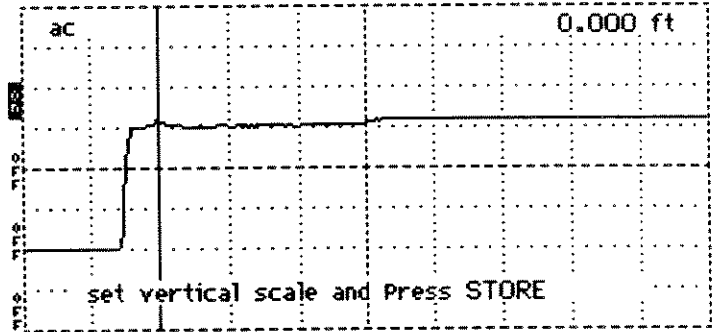

### Vertical Compensation for Higher Impedance Cable

When testing cables other than  $50\Omega$ , this procedure allows reflection measurements in millirho.

1. Attach a short sample of the given cable ( $75\ \Omega$  or the impedance in question). Adjust  $\Phi$  POSITION control to position reflected pulse center screen.
2. Turn NOISE FILTER to VERT SET REF.
3. Adjust VERT SCALE so reflected pulse (from open circuit at far end of cable sample) is two divisions high.
4. Press STORE. Return NOISE FILTER to desired setting.
5. Adjust  $\Phi$  POSITION control to desired position on waveform to measure loss.

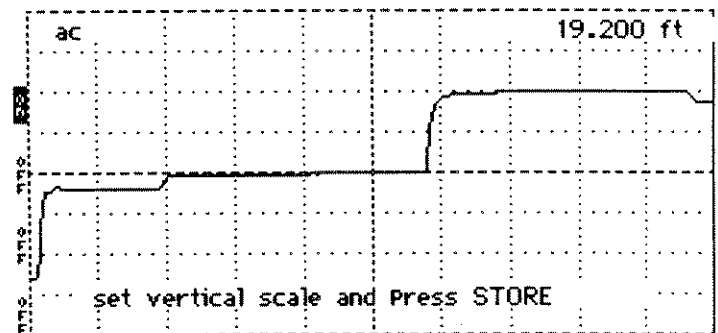
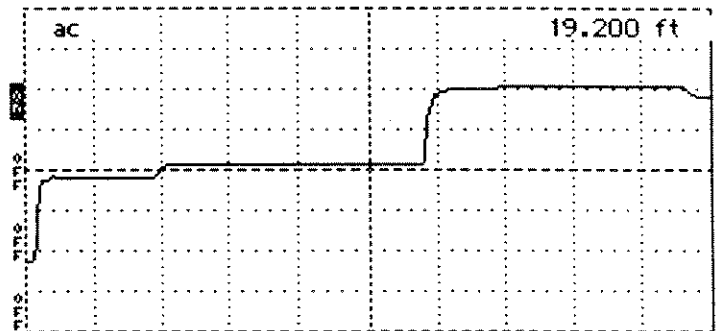

The instrument is now set to measure reflections in millirho relative to sample cable impedance.

To measure reflections on a  $50\Omega$  cable, Vert Set Ref must be reset.

#### To exit VERT SET REF

- a. Turn NOISE FILTER to VERT SET REF.
- b. Adjust VERT SCALE to obtain an incident pulse height of two divisions.
- c. Push STORE.
- d. Turn NOISE FILTER to desired filter setting.

The instrument can be turned off and back on to default to the two division pulse height.

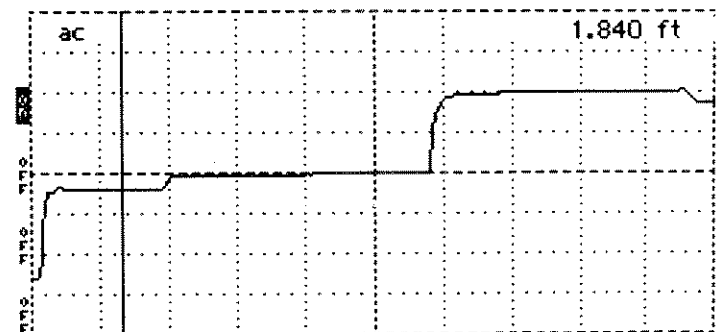

## Additional Features (Menu Selected)

### Max Hold

The 1502B will capture and store waveforms on an ongoing basis. This is useful when cable or wire is subjected to intermittent or periodic conditions. The 1502B will monitor the line and display any fluctuations on the LCD.

1. Attach cable to 1502B front panel. Push **MENU**. This will access the Main Menu.
2. Scroll to "Set Up Menu", and push **MENU**.
3. Scroll to "Acquisition Control Menu", and push **MENU**.
4. Scroll to "Max Hold is: Off", and push **MENU**. "Max Hold is: Off" will change to "On". The monitoring function is now ready to activate.
5. Repeatedly push **MENU** until the instrument is back in Normal Operation.
6. When ready to monitor, push **STORE**. The 1502B will now capture any changes in the cable.
7. Exit active monitor mode by pushing **STORE**.

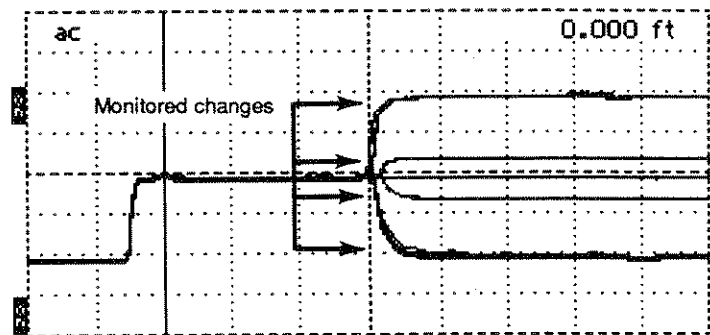
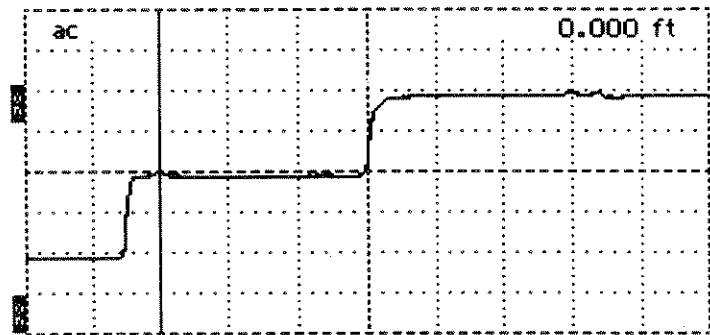
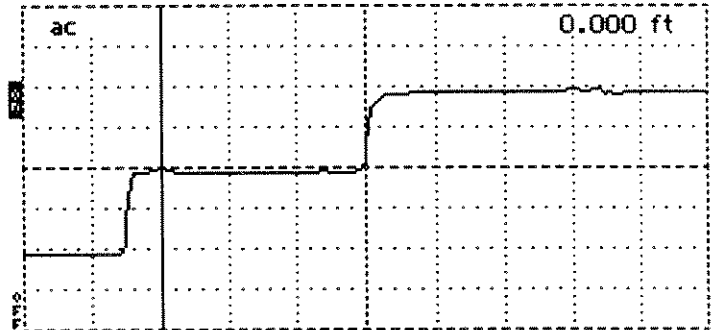

8. Exit **Max Hold** by accessing the "Acquisition Control Menu", turn off **MAX HOLD**, and push **MENU** repeatedly until instrument returns to Normal Operation mode.

## Pulse On/Off

This feature puts the 1502B in a "listening mode" by turning off the pulse generator.

1. Attach cable to the 1502B front panel. Push **MENU**. That will access the Main Menu.
2. Scroll to "Set Up Menu", and push **MENU**.
3. Scroll to "Acquisition Control Menu", and push **MENU**.
4. Scroll to "Pulse is: On". Push **MENU**. "Pulse is: On:" will change to "Off".
5. Repeatedly press **MENU** until instrument returns to Normal Operation mode.

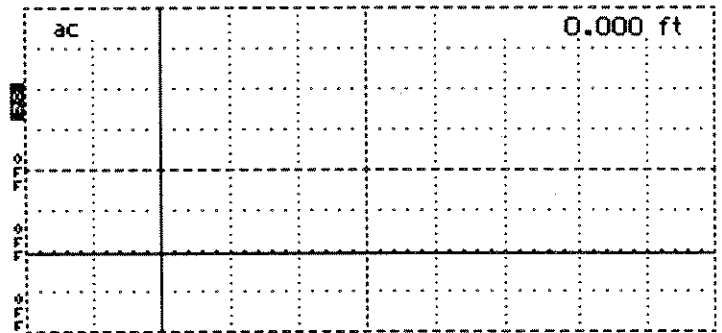

### CAUTION

*This function is used mostly for troubleshooting by qualified technicians. It is not recommended you use the 1502B as a stand alone monitoring device. The input circuitry is very sensitive and can be easily damaged by even moderate level signals.*

*In this mode, the 1502B is acting as a detector only. Any pulses detected will not originate from the instrument, consequently distance readings will be invalid. If listening to a local area network, for example, it is possible to detect traffic, but not possible to measure the distance to their origin.*

"Pulse is: On/Off" can be used in conjunction with "Max Hold is: On/Off".

6. To exit Pulse is: On/Off, access Acquisition Menu and turn function off. Then, repeatedly push **MENU** until instrument is in Normal Operation mode.

## Single Sweep

The single sweep function will acquire one waveform and display it.

1. Attach cable to 1502B front panel. Push **MENU**. That will access the Main Menu.
2. Scroll to "Set Up Menu", and push **MENU**.
3. Scroll to "Acquisition Control Menu", and push **MENU**.
4. Scroll to "Single Sweep is: Off", and push **MENU**. "Single Sweep is: Off" will change to "On".
5. Repeatedly push **MENU** until the instrument is back in the Normal Operation mode.

6. When ready to begin a sweep, push **VIEW INPUT**. A sweep will also be initiated when you change any of the front panel controls. This allows observing front panel changes without exiting the Single Sweep mode.

As in normal operation, averaged waveforms will take longer to acquire.

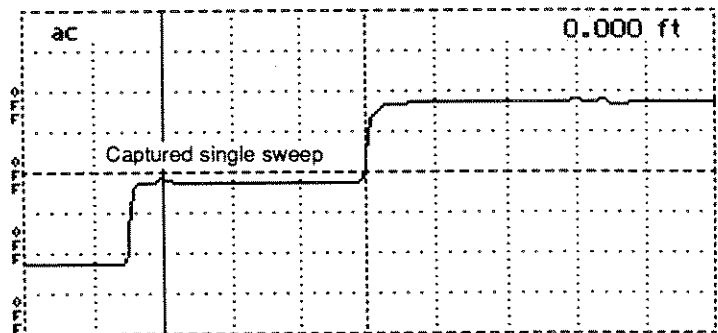

7. To exit **Single Sweep mode**, go into the Acquisition Menu and turn Single Sweep mode off. Then, repeatedly push **MENU** until the instrument returns to the Normal Operation mode.



## Operator Tutorial

The next few pages will demonstrate, step by step, the features and uses of the 1502B.

### What is the Tektronix 1502B?

The Tektronix 1502B Time Domain Reflectometer is a short range metallic cable tester capable of finding faults in metal cable. Tests can be made on coaxial, twisted pair, or parallel cable.

### How Does It Do It?

The 1502B sends an electrical pulse down the cable, and detects any reflections made by discontinuities. This is known as Time Domain Reflectometry. The 1502B is sensitive to impedance changes. Problems in the cable will be detected and displayed as changes in impedance along the cable. These will be displayed as hills and valleys in the reflected pulse. The 1502B is capable of finding shorts, opens, defects in the shield, foreign substances in the cable (water, etc.), kinks and more. Even though other instruments might show a cable as "good", the 1502B can show many previously "hidden" faults.

### YOU, the Operator

The 1502B is a highly accurate cable tester. It is easy to use, and will provide fast, accurate measurements. Because of electrical and environment differences in cables and their applications, each waveform will likely differ. The best way to learn these differences is experience with the instrument. You are the 1502B's most important feature. Experiment with different cables in known conditions and see how they compare. Subject cables to situations you might find in your application and learn their effects. We have included some examples of cable faults in this manual to help you gain familiarity. With practice, you will quickly become familiar with even the most subtle differences in waveforms.

### The MENU Screens

The 1502B is equipped with various help screens. Simply press **MENU** for assistance. The instrument will prompt you. More on MENU in the *Operator Instructions* located in this manual.

## Getting Started

Let's inspect a cable. For the next few examples, we'll be using the 3 foot precision test cable provided with the 1502B (Tek Part Number 012-0482-00).

1. Pull on the **POWER** switch. The instrument will initialize, give instructions for accessing the menu, and enter "Normal Operation" mode.
2. Set the 1502B front panel:

CABLE	Attach 3 ft cable
NOISE FILTER	1 avg
VERT SCALE	500 mp (default)
DIST/DIV	1 ft/DIV
<i>DIST/DIV (METRIC)</i>	<i>0.25 Metres</i>
$V_p$	.66

### IMPORTANT

$V_p$  (**Velocity of Propagation**) of the test cable is important for making accurate distance measurements. If you do not know the  $V_p$  factor of a cable, distance readings will be directly affected. You can get a general idea from the table on page 2-11, find the  $V_p$  with a sample cable using the procedure on page 2-12, or use the Cable Information Menu. If it is impossible to obtain the  $V_p$  of a cable, the instrument will still show cable faults, but the distance readings may be erroneous. The test cable used in this tutorial has a  $V_p$  of .66.

**VERT SCALE** will already be set to 500 mp/DIV (called the "default setting"). The cursor will be near the leading edge of the incident pulse (at the point on the waveform representing the front panel). Other information displayed includes the type of power used ("AC or bat"), and the **DISTANCE WINDOW**, 0.000 ft. This data will be displayed when the instrument is turned on in this manner. Push button switch status and other instrument functions are also displayed.

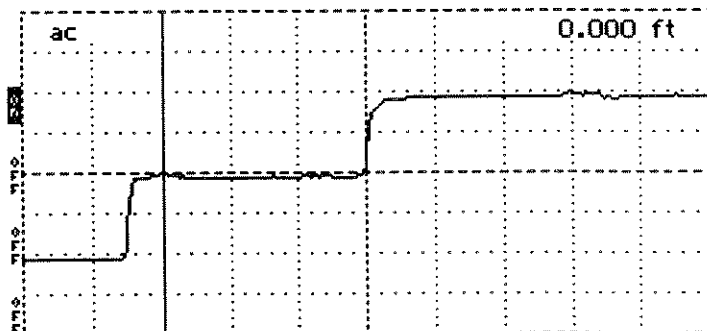

3. The rising pulse on the left is the test pulse (incident pulse) leaving the instrument. The rising reflected pulse on the right displays the echo coming back. Turn  $\diamond$  POSITION clockwise until the cursor rests on the rising edge of the reflected pulse. The upper right corner of the display (distance window) will read 3.000 feet. Note that the reflected pulse rises. This is the classic signature of an open cable, a point of higher impedance.

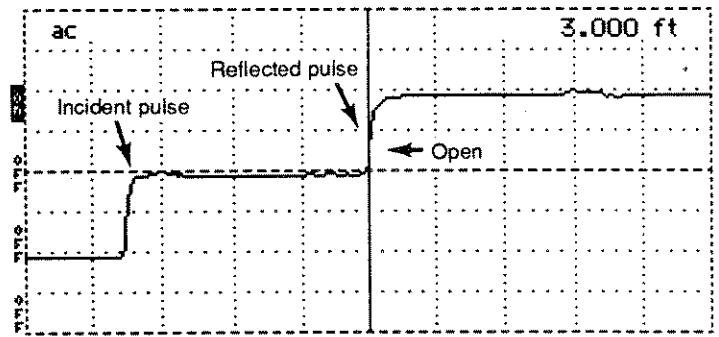

4. Adjust VERT SCALE control. This will increase or decrease the height of the pulse. For accurate measurements, the pulse should occupy most of the LCD. Note the LCD displays the VERT SCALE setting in mp. For now, set this control to 354 mp/DIV.

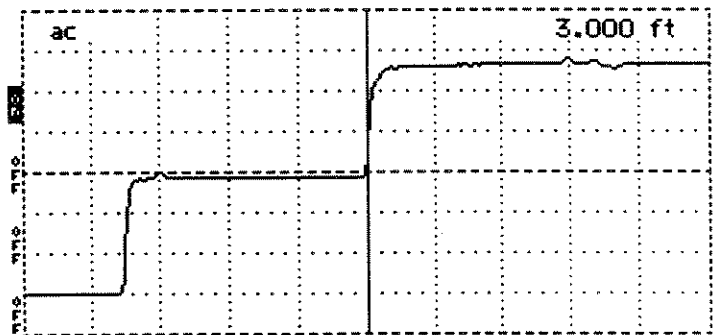

5.  $\diamond$  POSITION moves the trace up and down the display. Adjust for best viewing.

6. Short the end of the cable with an electrical clip or other suitable device. See the pulse take a dive? That's the classic signature of a short, a point of lower impedance. The distance window should still read 3.000 ft. If the short is not directly across the conductors of the BNC, e.g. needle nose pliers, the downward edge of the waveform may be slightly past the cursor indicating the length of the shorting device. Remove the short.

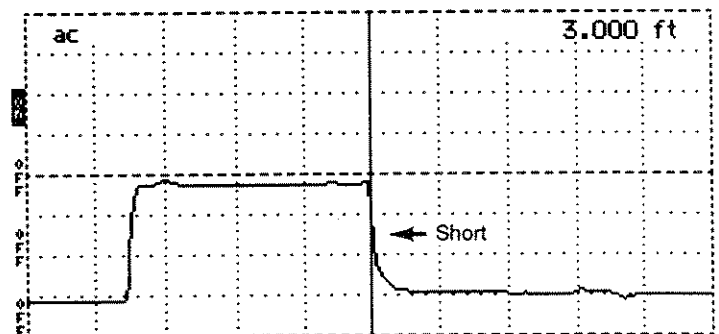

With a little practice, you can identify many kinds of cable faults.

## The Waveform Up Close

It helps to know the "ingredients" of the pulse. Here's the waveform anatomy using the 3 foot test cable as an example.

1. Turn  $\Phi$  POSITION counterclockwise until the distance window reads  $-2.000$  ft. The cursor will be on the far left side of the LCD, and the reflected pulse will be at near center screen. Set the 1502B front panel:

CABLE	Attach 3 ft cable (no short)
NOISE FILTER	1 avg
VERT SCALE	500 mp
DIST/DIV	1 ft
DIST/DIV (METRIC)	0.25 m
V <sub>p</sub>	.66

2. The first (left) step is the *incident pulse* as sent from the pulse generator. The second step is the *reflected pulse* as it bounces back from the end of the cable. The reflected pulse and the distance (time) between pulses provides the information needed for calculating the distance between faults or the end of the cable.

3. Adjust  $\Phi$  POSITION so the cursor rests on the rise of the incident pulse. Note the distance window reads approximately  $-0.520$  ft. This is the distance from the front panel BNC connector to the pulse generator circuit board (where the test pulse is generated).

4. Adjust VERT SCALE to approximately 25 mp. Adjust  $\Phi$  POSITION to keep the middle portion of the pulse on the display. The bumps following the incident pulse are aberrations from the internal circuitry, and reflections between the open end of the cable and the front panel.

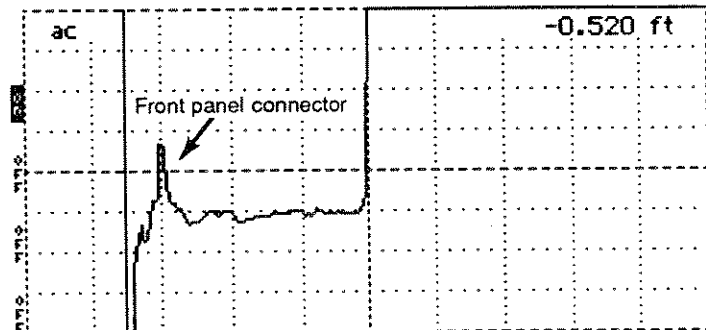
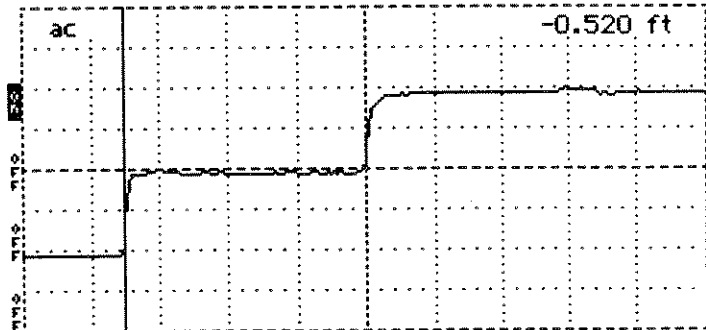
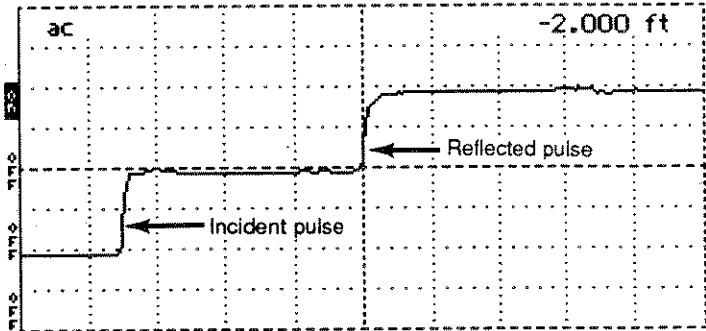

## A Longer Cable

Longer cables may not fit in the display. Let's demonstrate with a longer cable.

Obtain a known length of  $50\Omega$  cable. For this example, we're using a  $50\Omega$  coaxial cable approximately 452 feet long. Your cable length will likely differ, but the following procedure remains fundamentally correct for any cable length up to 2000 feet.

1. Set the 1502B front panel:

CABLE	Connect available cable.
NOISE FILTER	1 avg
VERT SCALE	500 mp
DIST/DIV	50 ft
DIST/DIV (METRIC)	25 m
V <sub>p</sub>	Appropriate setting.

2. With the above settings, we can view our entire cable. By placing the cursor at the rise of the reflected pulse, we can see this particular cable is 452.000 feet in length.

3. By decreasing the DIST/DIV control, the cable can be more closely inspected at the point of the cursor. Decrease the DIST/DIV to 10 FT/DIV. This has "expanded" the cable across the LCD. Turn  $\Phi$  POSITION counterclockwise. Note that the distance window changes as we "scroll" down the cable. In reality, we are *electrically* inspecting the cable foot by foot.

**NOTE:** When testing a long cable, it is helpful to set DIST/DIV to a higher setting when scrolling to either end of the cable. For example, if testing a 1500 foot cable, it would be very tiring to scroll the cable from end to end with DIST/DIV set at 1 FT/DIV!

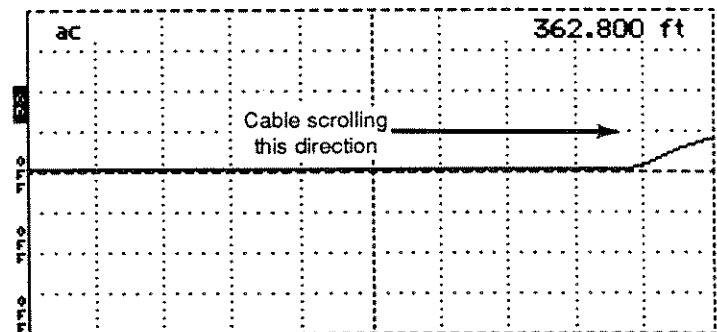
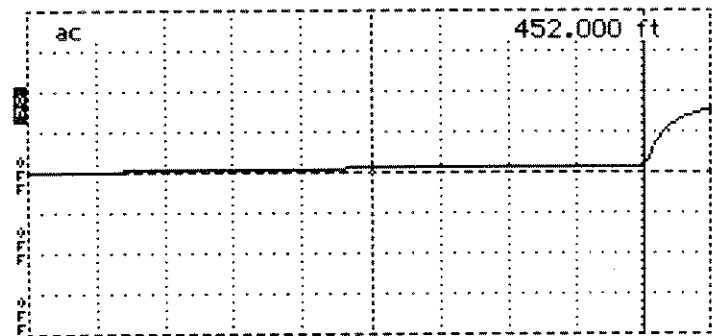
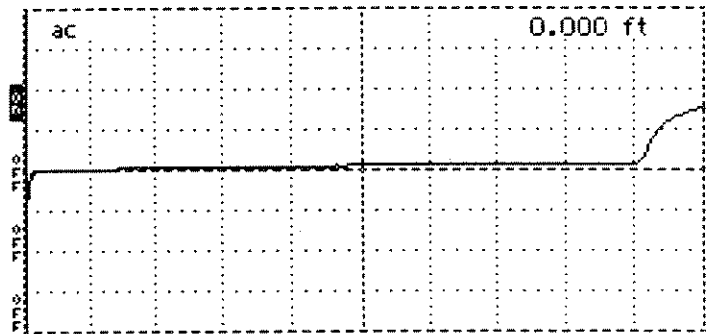

## Ohms-at-Cursor

Using the long cable as an example (use your own long cable), we can find out the impedance at the cursor.

1. Set the 1502B front panel:

CABLE	Connect available cable.
NOISE FILTER	1 avg
VERT SCALE	500 mp
DIST/DIV	50 ft
<i>DIST/DIV (METRIC)</i>	<i>25 m</i>
V <sub>p</sub>	.66

2. Press **MENU**. Scroll down to "Setup Menu". Press **MENU**.

3. Scroll down to "Ohms at the Cursor is: Off". Press **MENU**. This will turn on the ohms-at-cursor function. Press **MENU** repeatedly until the instrument returns to "Normal Operation" mode.

4. Turn the  $\Phi$  **POSITION** control to set the cursor near the end of the cable as illustrated. In our example, we see the the distance reading is 408.000 feet, and the ohms-at-cursor is 59.5 $\Omega$ . The ohms-at-cursor tells us the loss in the cable results in an impedance of 59.5 $\Omega$ . We can assume 50 $\Omega$  impedance plus 9.2 $\Omega$  series resistance. You can check this by putting a known reference on the end of the cable and measuring its impedance with ohms-at-cursor. The difference between the actual reading and the expected reference reading is the series resistance.

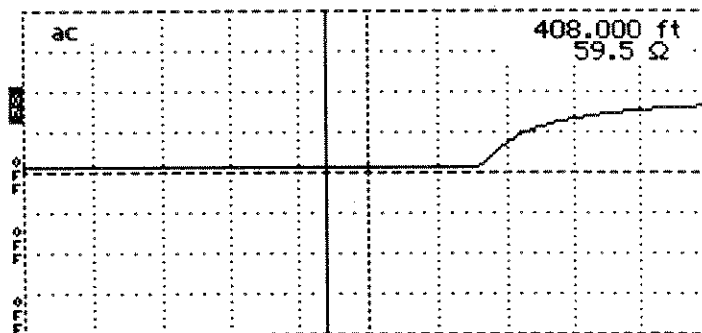

5. Turn the  $\Phi$  POSITION control to set the cursor near the beginning of the cable. In this example, the ohms-at-cursor is  $50.9\Omega$  at 17.880 ft. There is less loss at the beginning of the cable because of less series resistance.

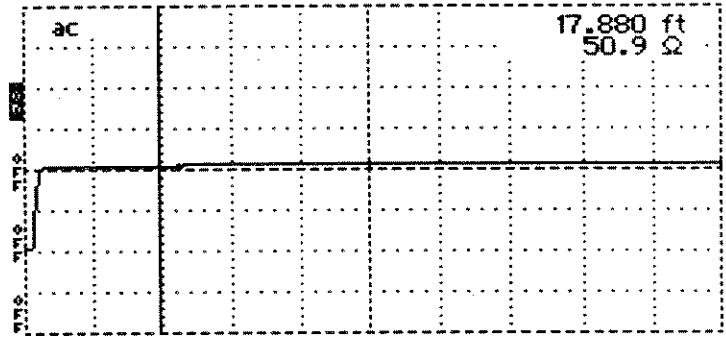

6. Turn the  $\Phi$  POSITION control clockwise to set the cursor past the reflected pulse. Now the ohms-at-cursor reads  $\geq 1K\Omega$ .

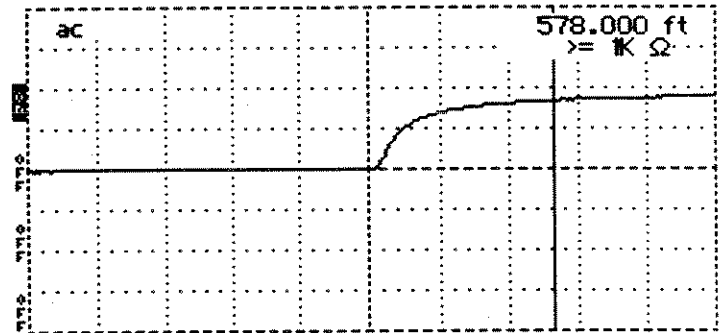

7. Turn  $\Phi$  POSITION clockwise until the cursor rests at the front panel (far left side, -2.000 ft distance). Ohms-at-cursor reads  $< 1\Omega$ .

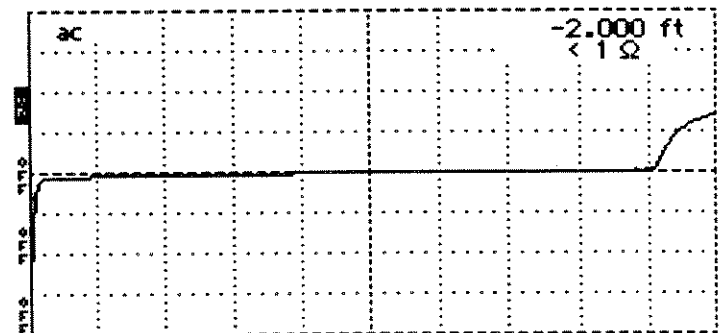

If the cursor is placed too near a fault, the reflection will not have stabilized so the reading will be misleading. This is especially true very near the instrument where some aberrations are still significant. See the section in the Operator Instructions for more details on the limitations of this feature.

## Noise

- On a longer cable, "grass" may appear on the display pulse. This is primarily caused by the cable acting as an antenna, picking up nearby electrical noise. To show this, set the 1502B front panel:

CABLE	Attach 3 ft cable
NOISE FILTER	1 avg
VERT SCALE	500 mp
DIST/DIV	1 ft
<i>DIST/DIV (METRIC)</i>	<i>0.25 m</i>
$V_p$	.66
◊ POSITION	40.000 ft

- Attach the 50 $\Omega$  terminator to the test cable using a female-to-female BNC adapter. (Both of these items are supplied with the instrument).
- Increase **VERT SCALE** to 1.00 mp. Use ◊ **POSITION** to keep the waveform on screen. As the **VERT SCALE** setting increases, there will be noise in the form of a moving, fuzz-like waveform with a few random spikes.

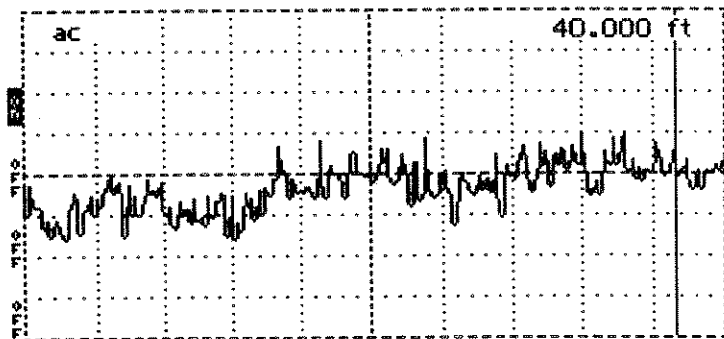

- Turn **NOISE FILTER** control clockwise to 8. This will "average out" some of the noise.

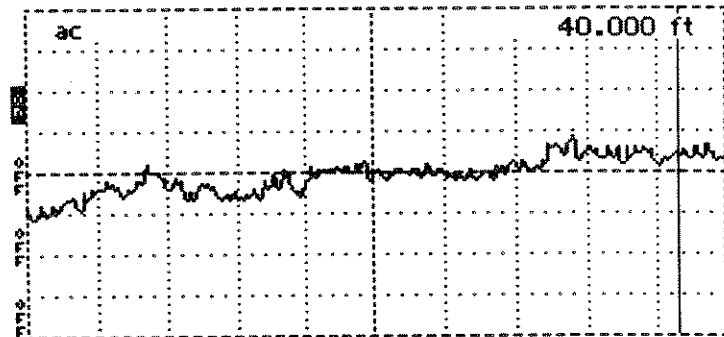

- Increase the **NOISE FILTER** setting to 128. *NOTE: The higher the setting, the more time the instrument takes to average the waveform.*

- Move ◊ **POSITION** and notice how averaging restarts at a low value to allow easy positioning.

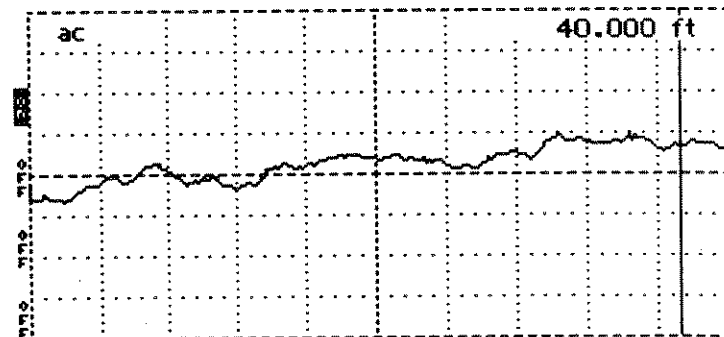

The 50 $\Omega$  terminator is used because it gives a good impedance match. Since there are no large discontinuities, it appears to the instrument as an "endless" cable. The noise seen in this demonstration is noise picked up on the cable, and some "internal" noise from the 1502B. When testing cables, the noise filter is extremely effective in reducing noise.



## Set Ref ( $\Delta$ Mode)

### HORZ SET REF

Horizontal Set Ref establishes the starting point at which the distance window begins reading the distance to the cursor. If, for example, you had a 3-foot cable leading to a patch panel, you could eliminate this jumper from your distance reading.

1. Set the 1502B front panel:

CABLE	Attach 3 ft cable
NOISE FILTER	1 avg
VERT SCALE	500 mp
DIST/DIV	1 ft
DIST/DIV (METRIC)	0.25 m

2. If **POWER** has been left on from previous step, return distance window reading to 0.000 ft with  $\diamond$  **POSITION** control.

There are the two familiar step pulses of the test cable. Turn **NOISE FILTER** counterclockwise to **HORZ SET REF**. The noise filter reading says "set  $\Delta$ ". (The **NOISE FILTER** control has three functions: **NOISE FILTER**, **HORZ SET REF**, and **VERT SET REF**.)

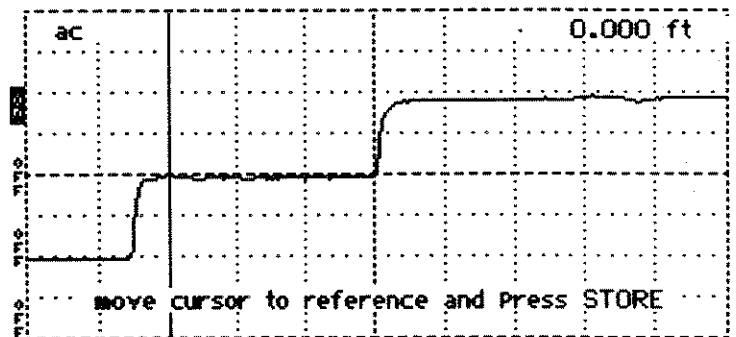

3. Adjust  $\diamond$  **POSITION** so the cursor is on the rise of the reflected pulse. Distance window should read 3.0 ft. Press **STORE**.

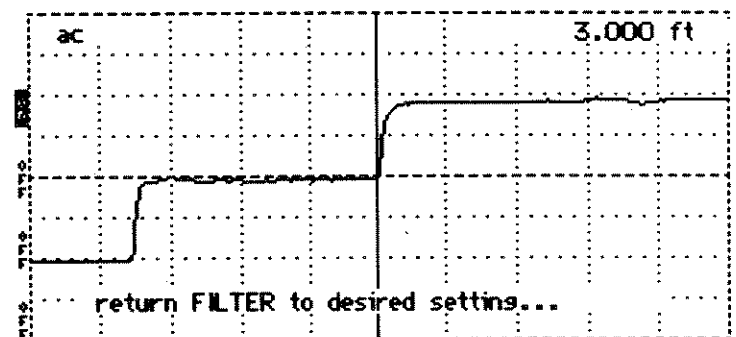

4. Turn **NOISE FILTER** control to 1 avg. Note that the distance window now reads "0.000 ft $\Delta$ ". This means everything from the front panel BNC to the end of the cable is subtracted from the distance calculations.

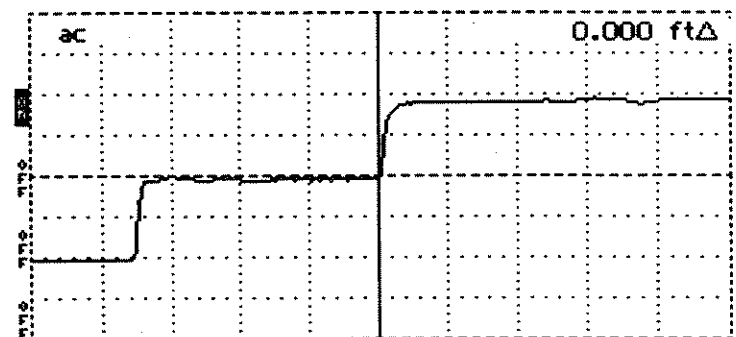

## 5. Changing or Exiting HORZ SET REF

Horz Set Ref can be changed by turning the **NOISE FILTER** back to HORZ SET REF and repeating the above procedure. If you wish to totally exit HORZ SET REF, do the following:

- a. Set **POSITION** to *exactly* 0.000 ft (you may have to set DIST/DIV to .1 ft).
- b. Push **STORE**.
- c. Turn **NOISE FILTER** to the desired noise setting.

## VERT SET REF

This control is nearly the same as the HORZ SET REF except it sets the vertical zero reference. It would be helpful to read the section on VERT SET REF in the Operator Instructions. This will give you some technical background on VERT SET REF.

The VERT SET REF function allows manual control of the vertical calibration of the 1502B. This can be used to compensate for cable loss or to increase the resolution of the millirho scale. The example below shows how to compensate for cable loss.

The reflection from an open or short at the far end of a long cable is often less than two divisions high at 500 mp/DIV. This is because of the energy lost in the cable. Here is how to correct for this loss and be able to make accurate measurements at the end of the cable.

1. To make this correction, open or short the cable (or another like cable in the bundle) at the far end.
2. Turn **NOISE FILTER** all the way counterclockwise to **VERT SET REF**. The display will prompt you and "Set Ref" will appear on the display above the **NOISE FILTER** control.
3. Adjust **VERT SCALE** until the reflection from the open (or short) is two divisions high. Press **STORE** and return **NOISE FILTER** to the desired setting.
4. The **VERT SCALE** will now read 500 mp/DIV.

Millirho measurements at the far end of the cable (or a similar cable in the bundle) can now be made using normal methods. To make measurements closer or farther from the instrument requires resetting the **VERT SET REF**.

Care must be taken in changing the **VERT SET REF** because of the calibration change. The 1502B automatically starts the pulse at two divisions high. When you change the vertical reference, you essentially defeat this function.

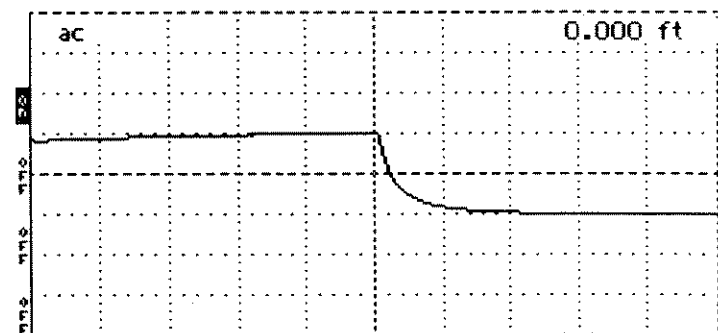
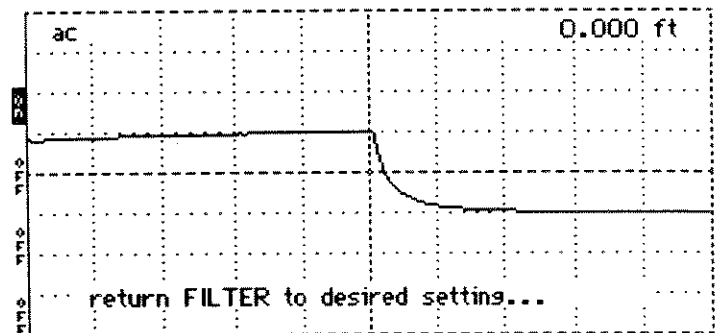
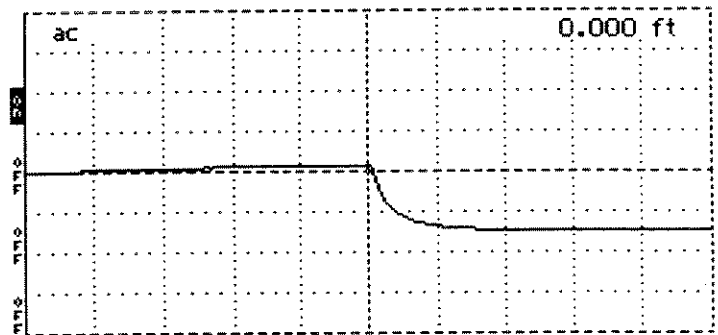

### 5. Changing or Exiting VERT SET REF

VERT SET REF can be changed by turning the **NOISE FILTER** back to VERT SET REF and repeating the above procedure. If you wish to totally exit VERT SET REF, do the following:

- a. Turn **NOISE FILTER** to VERT SET REF.
- b. Turn **VERT SCALE** for a pulse two divisions high.
- c. Push **STORE**.
- d. Return **NOISE FILTER** to desired setting.

This function can also be exited by turning the instrument off, and turning it back on. The automatic function will adjust the pulse to two divisions high.

## VIEW INPUT

This push button allows you to view what's coming in the **CABLE** connector, or eliminate it from the display.

1. Set the 1502B front panel:

CABLE	Attach 3 ft cable
NOISE FILTER	1 avg
VERT SCALE	500 mp
DIST/DIV	1 ft
<i>DIST/DIV (METRIC)</i>	<i>0.25 m</i>

2. Press **VIEW INPUT**. The indicator block on the LCD should read OFF and the waveform should disappear from the display.

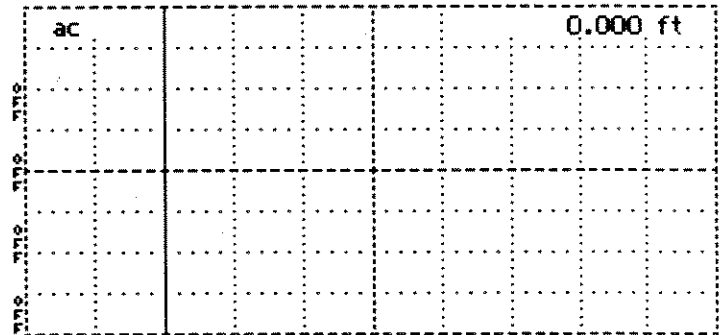

3. Press **VIEW INPUT**. The indicator block will re-appear as will the waveform.

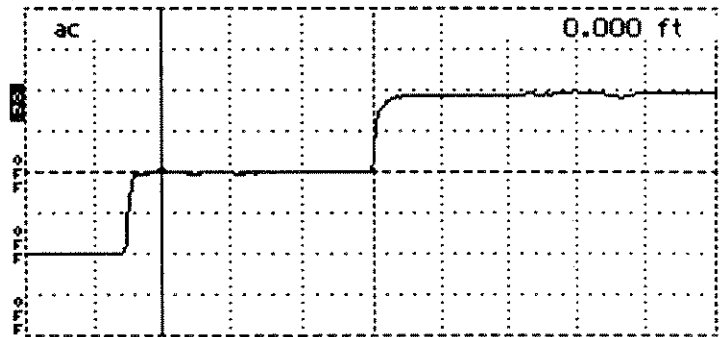

This function can be used to make the display less "busy" when viewing stored waveforms.

## STORE and VIEW STORE

These functions will allow you to store a waveform.

1. Set the 1502B front panel:

CABLE	Attach 3 ft cable
NOISE FILTER	1 avg
VERT SCALE	500 mp
DIST/DIV	1 ft
<i>DIST/DIV (METRIC)</i>	<i>0.25 m</i>

2. Make sure you have a waveform on the LCD. Adjust  $\phi$ POSITION to place the waveform in the upper portion of the display. Press **STORE**. The STORE indicator block should turn black and read "ON". The waveform is now stored in a non-volatile (permanent) memory in the instrument.
3. Turn **POWER** off for a few seconds. Turn **POWER** on. Note that the STORE indicator block is "ON", showing that the waveform has been stored.

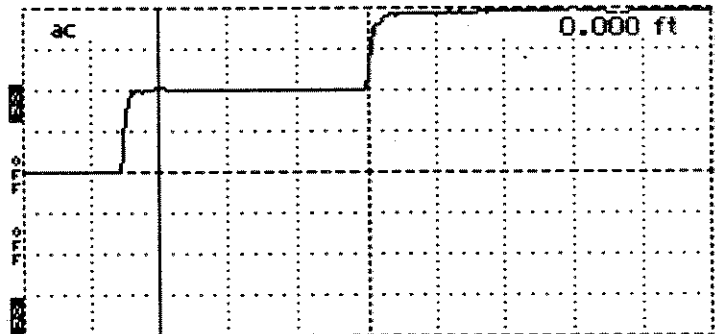

4. Short the inner conductor of the end of the test cable to the outer conductor of the test cable. The reflected pulse will drop below the baseline. Adjust  $\phi$ POSITION to place the trace in the middle portion of the LCD.

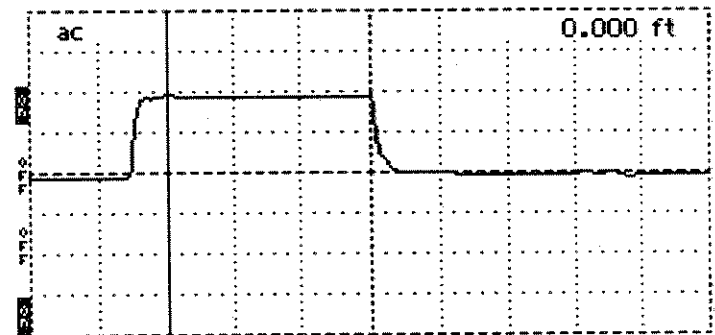

5. Press **VIEW STORE**. What you see on the display is the waveform you stored previously (**VIEW STORE**), and the current waveform (**VIEW INPUT**). The top waveform is an "open" (**VIEW STORE**), and the one on the bottom (**VIEW INPUT**) is a "short".

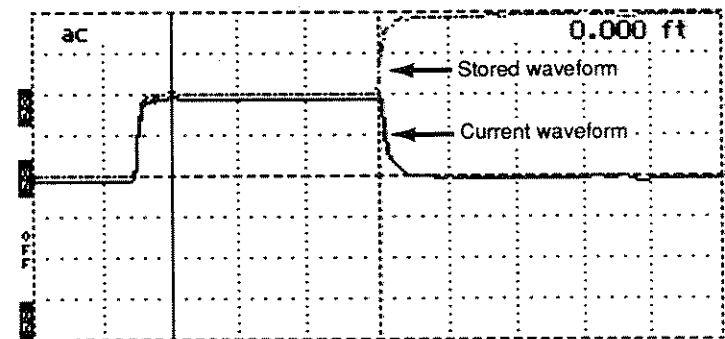

Comparing new cables with old cables, or repaired cables with damaged cables is easy using these two push buttons. **Leave the instrument settings "as is" for the next step.**

## VIEW DIFF

1. Press **VIEW DIFF**. This waveform is the difference between the **VIEW STORE** waveform and the **VIEW INPUT** waveform. If no waveform has been stored in the memory, an error message will be displayed.

*NOTE: There must be a waveform stored before it can be compared by the VIEW DIFF function.*

*NOTE: If the waveform STOREd and the VIEW INPUT waveform are identical, the difference will appear as a straight line.*

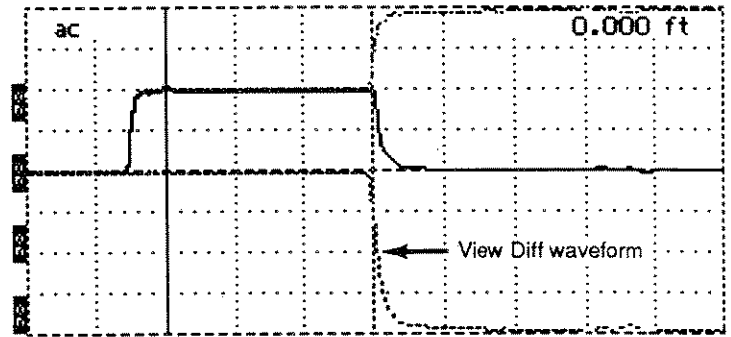

## Menu Accessed Functions

If you get confused or lost while in a MENU, repeatedly press **MENU** until the instrument returns to "Normal Operation" mode.

### Max Hold

1. Set the 1502B front panel:
 

CABLE	Attach 3 ft cable
NOISE FILTER	1 avg
VERT SCALE	500 mp
DIST/DIV	1 ft
<i>DIST/DIV (METRIC)</i>	<i>0.25 m</i>
  
2. Pull **POWER** on. Press **MENU** to access the Main Menu. With the  $\odot$  **POSITION** control, scroll down to "Setup Menu" and press **MENU**.
  
3. Scroll down to "Acquisition Menu" and press **MENU**.
  
4. Scroll down to "Max Hold is:" and press **MENU**. The menu will change from "Max Hold is: Off", to "Max Hold is: On". The Max Hold function is now ready. Read the screen instructions. Press **MENU**.
  
5. Press **MENU** again to exit the Acquisition Control Menu.
  
6. Press **MENU** again to exit the Setup Menu.
  
7. Press **MENU** again to enter "Normal Operation" mode. Note that **VIEW STORE** and **VIEW DIFF** indicator blocks have disappeared. This tells you that both of these functions are inoperative.

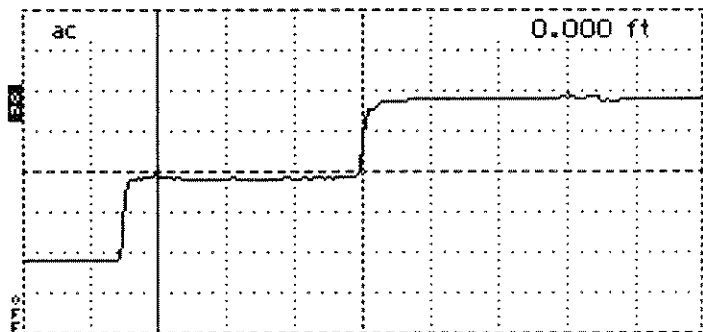



8. Press **STORE**. This activates the Max Hold function, and the STORE indicator block is dark. With a clip lead or other device, short the end of the test cable and remove. Note that the short has been left on the display.

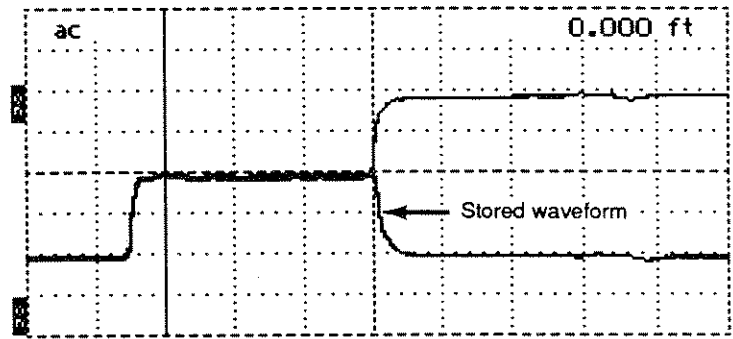

9. Turn  $\Delta$  **POSITION** control counterclockwise. The waveform will "strobe" down the display, leaving traces of its movements.
10. Press **STORE**. The display will clear, awaiting **STORE** to be pressed again, activating another Max Hold monitor cycle.

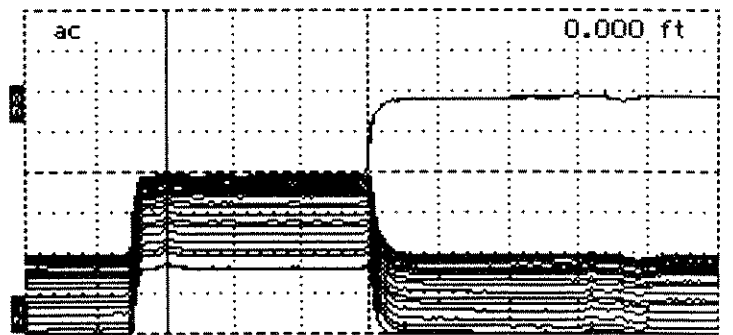

You can see how this function is useful for monitoring lines for changes over a period of time, or for intermittent conditions. For example:

- a) A coastal phone line only has problems during high tide. Overnight monitoring reveals water in the line during the high tide period.
- b) A data communications line is monitored for an intermittent short. Three days of monitoring reveals the shorts occur only during the hours of darkness. Rodents are found in the cable ducts.
- c) A cable becomes defective only during daytime hours. Monitoring reveals the line length increases (sags) during the heat of the day, shorting out on a tree limb. During the night the cable cools, tightens, and is no longer shorted on the tree limb.

## Pulse On/Off

1. Set the 1502B front panel:
 

CABLE	Attach 3 ft cable
NOISE FILTER	1 avg
VERT SCALE	500 mp
DIST/DIV	1 ft
<i>DIST/DIV (METRIC)</i>	<i>0.25 m</i>
  
2. Pull **POWER** on. Press **MENU** to access the Main Menu. Scroll down to "Setup Menu" and press **MENU**.
  
3. Scroll down to "Acquisition Control Menu" and press **MENU**.
  
4. Scroll down to "Pulse is:" and press **MENU**. The menu will change from "Pulse is: On" to "Pulse is: Off".
  
5. Press **MENU** until instrument enters the "Normal Operation" mode.

**CAUTION**

*This function is used mostly for troubleshooting by qualified technicians. It is not recommended you use the 1502B as a stand alone monitoring device. The input circuitry is very sensitive and can be easily damaged by even moderate level signals.*

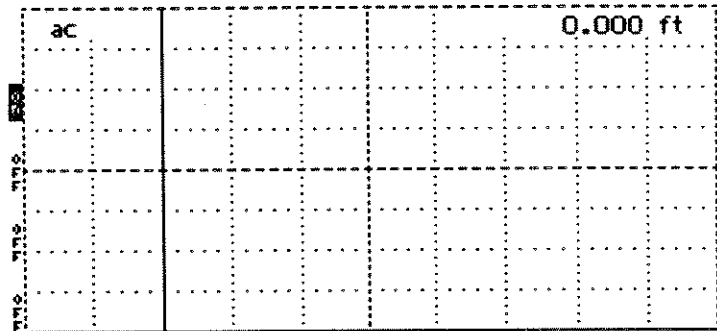

6. To turn the pulse back on, enter the "Acquisition Control Menu". Scroll to "Pulse is: On" and press **MENU**. Follow the usual procedure to return to enter "Normal Operation" mode.

## Single Sweep

- Set the 1502B front panel:
 

CABLE	Attach 3 ft cable
NOISE FILTER	1 avg
VERT SCALE	500 mp
DIST/DIV	1 ft
<i>DIST/DIV (METRIC)</i>	<i>0.25 m</i>
- Press **MENU** to access the Main Menu. Scroll down to "Setup Menu" and press **MENU**.
- Scroll down to "Acquisition Control Menu" and press **MENU**.
- Scroll down to "Single Sweep is:" and press **MENU**. The menu will change from "Single Sweep is: Off" to "Single Sweep is: On".
- Press **MENU** to exit the Acquisition Control Menu.
- Press **MENU** again to exit the Setup Menu.
- Press **MENU** again to enter "Normal Operation" mode. The waveform now on the display is the familiar test cable.

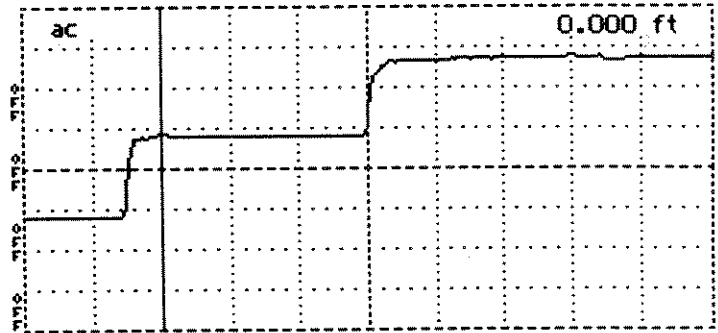

- Now short the end of the test cable with a clip lead. Press **VIEW INPUT**. The 1502B has done a single sweep, capturing just one "frame". Remove the short and notice that the waveform does not change. Press **VIEW INPUT** again and a new sweep will be made and displayed showing the change in the cable.

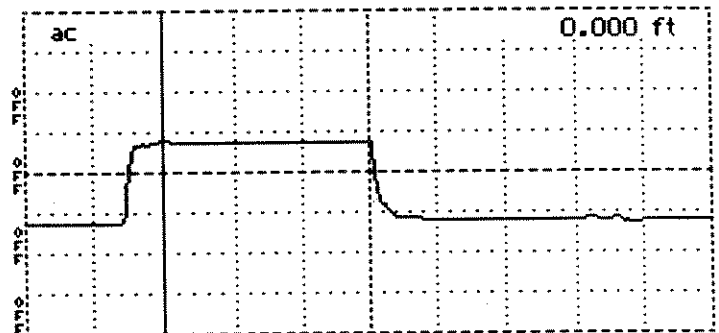

Single Sweep is useful for snap-shot tests of the cable, capturing just one waveform.

- To exit Single Sweep, follow the above procedure, turning off Single Sweep after entering "Acquisition Control Menu".

## TDR Questions and Answers

1. *What does TDR stand for?*

Time Domain Reflectometer.

2. *What is the difference between time domain and frequency domain?*

Within the time domain, things are expressed in units of time, e.g. nanoseconds. In the frequency domain, things are expressed in cycles, or *frequency*, e.g. kilohertz.

3. *What does a TDR actually measure?*

Voltage over time.

4. *How does a TDR display this information?*

Voltage on the vertical axis (amplitude), and time (distance) on the horizontal axis.

5. *Does electricity travel the same speed (velocity) in all materials?*

No. Electricity is like light. Its velocity is affected by the material through which it passes.

6. *What is this difference called?*

The relative velocity of propagation ( $V_p$ ). The velocity of the cable is expressed in time/distance, e.g. feet per nanosecond. The velocity of electricity traveling in a vacuum is compared to the velocity of electricity traveling in a cable. This relationship is shown as a decimal. A relative propagation velocity of .5 would mean the electricity would travel half as fast as it would in a vacuum.

7. *If a reflection takes 30 nanoseconds to return in a cable with a  $V_p$  of .66, how far away is the point on the cable that caused the reflection?*

The time one way would be 30 divided by 2, or 15 nanoseconds. The velocity of 1 nanosecond per foot in a vacuum would mean a distance of 15 feet. Since the cable is slower, we multiply the distance by the  $V_p$  (.66), and arrive at a distance of 10 feet. Of course, the 1502B TDR does all this automatically and displays the information on the LCD.

8. *What is resistance?*

Resistance is the opposition of DC current, or the DC voltage divided by the DC current.

9. *What is impedance?*

Impedance is the total opposition (resistance plus reactance) a circuit offers to the flow of alternating current at a given frequency.

10. *What factors determine the resistance of a cable?*

The cross section, length and material of the conductive material (usually copper).

11. *What factors determine the impedance of a cable?*

Dielectric value of the insulation and geometry of the conductors.

12. *Why should cables of the same impedance be used?*

Because a mismatch of impedance means a loss of energy at the mismatch.

13. *Why is all this important to us?*

Because a TDR displays the energy reflected back from an impedance mismatch.

## GLOSSARY

### aberrations

Imperfections or variations from a desired signal. In TDRs a pulse of electrical energy is sent out over the cable. As the pulse generating circuitry is turned on and off the pulse is often distorted slightly and no longer a perfect step or sine shaped waveform.

### AC

Alternating current is a method of delivering electrical energy by periodically changing the direction of the flow of electrons in the circuit or cable. Even electrical signals designed to deliver direct current (DC) usually fluctuate enough to have an AC component.

### cable

Electrical conductors that are usually insulated and often shielded. Most cables are made of metal and are designed to deliver electrical energy from a source (such as a radio transmitter) across a distance to a load (such as an antenna) with minimal energy loss. Most cables consist of two conductors, one to deliver the electrical signal and another to act as a return path which keeps both ends of the circuit at nearly the same electrical potential. In early electrical systems and modern systems that over long distances the earth and/or air was used as the return path and the term ground or ground wire is often used to describe one of the wires in a cable pair.

### cable fault

Any condition that makes the cable less efficient at delivering electrical energy than it was designed to be. Water leaking through the insulation, poorly mated connectors and bad splices are typical kinds of cable faults.

### capacitance

(See reactance)

### characteristic impedance

Cables are designed to match the source and load for the electrical energy they carry. The designed impedance is often called the characteristic impedance of the cable. The arrangement of the conductors with respect to each other is the major factor in designing the impedance of cables.

### conductor

Any substance that will readily allow electricity to flow through it. Good conductors are metals such as silver, copper, gold, aluminum, and zinc (in that order).

**dB**

dB stands for decibel. Decibels are a method of expressing power or voltage ratios. The decibel scale is logarithmic. It is often used to express the efficiency of power distribution systems when the ratio consists of the energy put into the system divided by the energy delivered (or in some cases lost) by the system. The formula for decibels is:  $dB = 20 \log(V_i/V_r)$  where  $V_i$  is the voltage of the incident pulse,  $V_r$  is the voltage reflected back by the load, and  $\log$  is the decimal based logarithmic function. The dB vertical scale on our instrument refers to the amount of voltage gain (amplification) the instrument applies to the signal before displaying it. For example, when the instrument is amplifying the voltage by one hundred, the dB scale would read 40 dB which is  $20 * \log(100)$ .

**DC**

Direct current is a method of delivering electrical energy by maintaining a constant flow of electrons in one direction. Even circuits designed to generate only alternating current (AC) often have a DC component.

**dielectric**

(See insulation)

**domain**

Is a mathematical term that refers to the set of numbers that can be put into a function (the set of numbers that comes out of the function is called the range). A time domain instrument performs its function by measuring time.

**impedance**

Is the total opposition to flow of electrical energy in a cable or circuit. Impedance is made partly of resistance (opposition to DC) and partly of reactance (opposition to AC). Although impedance is expressed in units of ohms, it must not be confused with simple resistance which only applies to DC signals. Technically impedance is a function of the frequency of the electrical signal, so it should be specified at a frequency. As a practical matter, the impedance of most cables changes very little over the range of frequencies they were designed for.

**impedance mismatch**

Is a point in a cable or system where electrical energy is lost because of a significant change in the opposition to the flow of electrical energy.

**incident pulse**

The pulse of electrical energy sent out by the TDR. The waveform shown by the TDR consists of this pulse and the reflections of it coming back from the cable or circuit being tested.

**inductance**

(See reactance)

**insulation**

A protective coating on a electrical conductor that will not readily allow electrical energy to flow away from the conductive part of the cable or circuit. Insulation is also called dielectric. The kind of dielectric used in a cable determines how fast electricity can travel through that cable (*see velocity of propagation*).

**jitter**

Is the short term error or uncertainty in the clock (timebase) of a TDR. If the timing from sample to sample is not exact, the waveform will appear to move back and forth rapidly.

**LCD**

Stands for liquid crystal display. It is the kind of display used on this instrument, so the terms display and LCD are often used interchangeably in this manual.

**millirho**

rho ( $\rho$ ) is the reflection coefficient of a cable or power delivery system. It is the ratio of the voltage applied to the cable divided by the voltage reflected back from the cable or circuit due to cable faults or an impedance mismatch at the load. Millirho are thousandths of one rho. Rho measurements are often used to judge how well the cable is matched to the load at the other end of the cable. If there is a open circuit in the cable, nearly all the energy will be reflected back when a pulse is sent down the cable. The reflected voltage will equal the incident pulse voltage and rho will be +1. If there is a short circuit in the cable, nearly all the energy will be delivered back to the instrument through the ground or return conductor instead of being sent on to the load. The polarity of the reflected pulse will be the opposite of the incident pulse and rho will be -1. If there is no mismatch between the cable and the load, almost no energy will be reflected back and rho will be 0. In general, a load or fault with a higher impedance than the cable will return a rho measurement of 0 to +1 and a load or fault with a lower impedance will return a rho measurement of 0 to -1. The scale for rho measurements is determined by the height of the incident pulse. A pulse two divisions high means that each division is .5 rho or 500 millirho. A pulse set to be four divisions high would make each division .25 rho (250 millirho).

**noise**

Any unwanted electrical energy that interferes with a signal or measurement. Most noise is random with respect to the signals sent by the TDR to make a measurement and will appear as the waveform constantly moving up and down on the display. The NOISE FILTER control sets how many waveforms will be averaged together to make the waveform displayed. Noisy waveforms appear to fluctuate around the real signal. Since it is random, noise will sometimes add to the real signal and sometimes subtract energy from the real signal. By adding several noisy waveforms together the noise can be "averaged" out of the signal since the average amount of noise adding to the signal will be nearly the same as the average amount of noise subtracting from the signal. More waveforms in an average are more likely to approach the real signal (although it takes longer to acquire and add together more waveforms).

**open circuit**

In a cable, a broken conductor will not allow electrical energy to flow through it. These circuits are also called broken circuits. The circuit is "open" to the air (which looks like a very high impedance).



**reactance**

Is a conductor's opposition to the flow of AC electrical energy through it. All conductors have some reactance. Reactance is made up of capacitance and inductance. Capacitance is the ability of conductors separated by thin layers of insulation (dielectric) to store energy between them. Inductance is the ability of a conductor to produce induced voltage when the electrical current through it varies. All conductors have some capacitance and inductance, so all conductors have some reactance which means they all have impedance.

**reflectometer**

An instrument that uses reflections to make measurements. Our reflectometers use electrical energy that is reflected back from points along a cable.

**resistance**

Is a conductor's opposition to the flow of DC electrical energy through it. All conductors have a certain amount of resistance. Resistance is the low (or zero) frequency part of impedance.

**return loss**

The amount of energy reflected or returned from a cable indicates how much energy is lost or not available to the load at the other end. The ratio of the energy sent out by the TDR divided by the energy reflected back expressed in the logarithmic dB scale is called return loss.

**rho ( $\rho$ )**

(See millirho)

**risetime**

The length of time it takes a pulse signal to go from 10% to 90% of the change in voltage.

**RMS**

Stands for root mean squared. RMS is a way of measuring how much deviation there is from a known (or desired) waveform. It is also the method used to calculate how much DC power is contained in an AC waveform.

**sampling efficiency**

Our instruments make measurements by taking a succession of samples in time and displaying them as a waveform with voltage on the vertical scale (up and down) and time along the horizontal scale (across the display). The circuitry that captures and holds the samples can not instantly change from one voltage level to another. It may take the circuit several samples to "settle in" at the new voltage after a rapid change in the waveform. How efficiently the circuit moves from one sampled voltage level to the next is called sampling efficiency. If the efficiency is too low, the waveforms will be smoothed or rounded. If the efficiency is too high (above 100%) the circuit will actually move beyond the new voltage level in a phenomena known as overshoot which becomes an unwanted source of noise in the waveform.

**series loss**

Conductors all have some DC resistance to the flow of electrical energy through them. The amount of resistance per unit length is usually nearly constant for a cable. The energy lost overcoming this series of resistances is called series loss. The series loss must be compensated for when measuring the return loss or impedance mismatch at the far end of long cables.

**short circuit**

In a cable, a short circuit is a place where the signal conductor comes into electrical contact with a return path or ground conductor. The electrical circuit is actually "shorter" than was intended. Short circuits are caused by worn, leaky, or missing insulation.

**TDR**

Stands for *time domain reflectometer*. These instruments are also called cable radar. They send out pulses of energy and time the interval to reflections. If the velocity of the energy through the cable is known, distances to faults in the cable can be displayed or computed. Conversely, the speed that energy travels through a cable of known length can also be computed. The way in which the energy is reflected and the amount of the energy reflected indicate the condition of the cable.

**velocity of propagation ( $V_p$ )**

Electrical energy travels at the same speed as light in a vacuum. It travels slower than that everywhere else. The speed that it travels in a cable is often expressed as the relative velocity of propagation. This value is just the ratio of the speed in the cable to the speed of light (so it is always a number from 0 to 1). A velocity of propagation value of .50 indicates that the electrical energy moves through the cable at half the speed of light.

**waveform averaging**

(See noise)

## Troubleshooting

For assistance in troubleshooting, use the following flow chart to determine if you have a simple problem you can fix, or if the instrument needs to be sent to a Tektronix Service Center.

Use the process to determine whether the instrument should be repaired or is OK to use when you have a problem.

**CAUTION:** Any time the instrument smells hot, repeatedly blows fuses or repeats the same error message you should have the instrument serviced by qualified technicians using the procedures in the service manual.

These are the first checks you should perform when you think you might have a problem with the instrument.

The first step asks you to preset the instrument controls. Here is how to do that: Set Vp to .66, turn the Impedance knob all the way counter clockwise, turn the Filter knob all the way counter clockwise & then back two clicks, turn the Dist/Div knob all the way counter clockwise & then back three clicks, turn the Pulse Width knob all the way counter clockwise, remove any accessories that plug into the option port (chart printer, etc...) and disconnect any cable that may be attached to the front panel connector.

To complete the tests you may need a volt/ohmmeter (VOM), a flat bladed screwdriver (to set the line voltage switch) and possibly some spare fuses.

When you have completed these tests you will know that it is safe to use the instrument or that it needs repair or adjustment with the case removed (you will not have to remove the case for these tests).

**IMPORTANT:** It is possible for the instrument to continue to make some measurements even after reporting an error message. **DO NOT IGNORE REPEATED ERROR MESSAGES!!!!** They indicate something wrong & should be used with the Service manual troubleshooting procedures.

This procedure will give you good confidence that the instrument is functioning well. It is not an exhaustive set of tests that guarantee that the instrument meets all specifications & is in good calibration. The instrument calibration procedures in the Service manual are the best method for assuring all specifications.

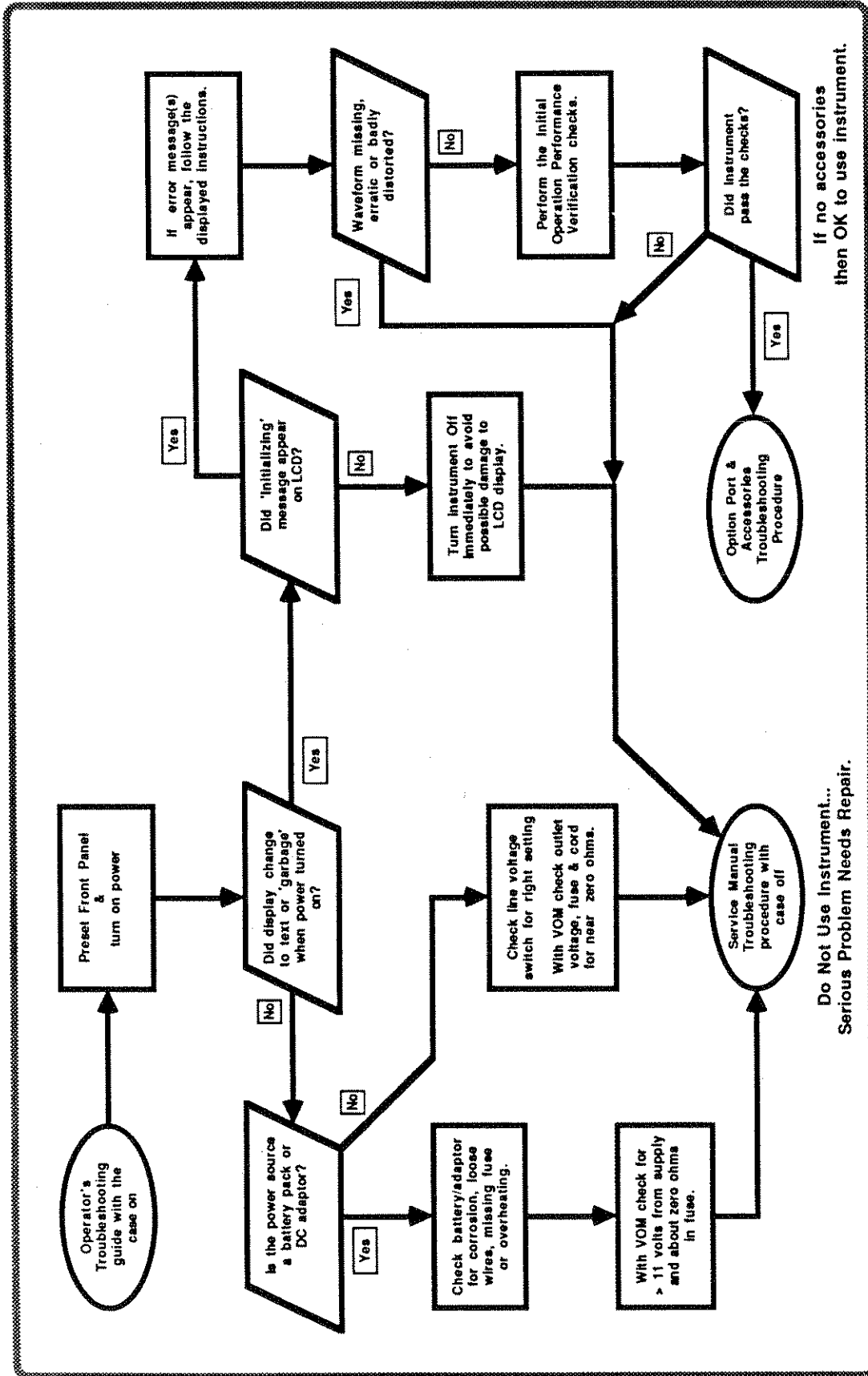



# GENERAL INFORMATION & SPECIFICATION

## General Information

### Product Description

The Tektronix 1502B Metallic Cable Time Domain Reflectometer is a cable test instrument that uses radar principles to determine the electrical characteristics of metallic cables.

The 1502B generates a rapidly rising step signal, applies it to the cable under test, and detects and processes the reflected voltage waveform from the cable. These reflections are displayed on the 1502B's liquid crystal display (LCD) where distance measurements may be made using a cursor. Impedance information may be obtained by interpreting waveform amplitude.

The waveform may be temporarily stored within the 1502B and recalled; or may be printed using the optional dot matrix strip chart recorder, which installs into the front panel Option Port.

### Battery Pack

The 1502B may be operated from either a 115 VAC or 230 VAC line or an optional internal battery pack consisting of nine C-cells supplying a minimum of five hours operating time (see specification, *Table 1-1*).

## Standards, Documents, and References Used

Terminology used in this manual is in accordance with industry practice. Abbreviations are in accordance with ANSI Y1.1-1972, with exceptions and additions explained in parentheses in the text. Graphic symbology is based on ANSI Y32.2-1975. Logic symbology is based on ANSI Y32.14-1973 and manufacturer's data books or sheets. A copy of ANSI standards may be obtained from the Institute of Electrical and Electronic Engineers, 345 47th Street, New York, NY 10017.

## Change and History Information

Changes that involve manual corrections and/or additional data will be incorporated into the text and that page will show a revisions date (e.g. REV JAN 1988) on the inside bottom edge. History information is included in diagrams in grey.

## Specification

The tables on the following pages list the characteristics and features that apply to this instrument.

The Performance Requirement column describes the limits of the Characteristic. Supplemental Information describes features and typical values or other helpful information.

The *Operating Instructions* contain procedures that check many of the functions of the 1502B. Procedures to verify the Performance Requirement are provided in the *Calibration* section of this manual.

Table 1-1  
ELECTRICAL CHARACTERISTICS

Characteristic	Performance Requirement	Supplemental Information
Excitation Pulse		
Reflected Rise	≤200 ps (0.096 feet)	V <sub>p</sub> set to 0.99; 10 to 90%, into a precision short
Aberrations	±5% peak within 0 to 10 feet after rise. ±0.5% peak beyond 10 feet	Not including front panel BNC
Jitter	≤0.02 feet (≤40ps) peak to peak ≤0.2 feet (≤400ps) peak to peak	V <sub>p</sub> set to 0.99 Horz Scale set to 0.1 ft/Div Horz scale set to 1 ft/Div
Output Impedance	50 ohm nominal	While pulse is on Typically ±1%
Pulse Amplitude		300 mv nominal into 50Ω load
Pulse Width		25 μs nominal
Pulse Repetition Time		200 μs nominal
Vertical Scales	0.5 mp/Div to 500mp/Div	Greater than 240 values including 1,2,5 sequences (accuracy depends on reference level)
Accuracy	Within ±3% of full scale range	
Set adj		Set incident pulse within ±3%. Combined with Vert Scale control
Vertical Position		Any waveform point movable to center screen
Displayed Noise	±5mp peak or less, Filter set to 1 ±2mp peak or less, Filter set to 8	



Table 1-1  
ELECTRICAL CHARACTERISTICS (con't)

Characteristic	Performance Requirement	Supplemental Information
Distance Cursor		
Resolution		1/25th of 1 major div.
Cursor Readout		
Range		-2 feet to $\geq 2000$ ft
Resolution		0.004 ft.
Accuracy	Within 2% $\pm 0.002$ ft of readout at 0.1 ft/div	$V_p$ must be set $\pm 0.5\%$
Cursor Ohms Readout		
Range		1 $\Omega$ to 1K $\Omega$
Resolution		3 significant digits
Accuracy		$\pm 10\%$ with serial cable impedance correction (relative impedance measurements $\pm 2\%$ )
Horizontal Scales		0.1 ft/DIV to 200 ft/Div <i>METRES: .025 m/DIV to 50 m/Div</i> 11 values; 1,2,5 sequences
Range		1 ft to 2000 ft <i>METRES: 2.5 meters to 500 meters</i>
Horizontal Position		Any distance to full scale may be moved on screen.
$V_p$ Range		0.30 to 0.99 Propagation Velocity relative to air.
Resolution		0.01
Accuracy	Within $\pm 1\%$	
Custom Option Port		Tek YT-1 is designed to operate with the 1502B. Produces a high resolution thermal dot matrix recording of waveform and switch values.

Table 1-1  
ELECTRICAL CHARACTERISTICS (con't)

Characteristic	Performance Requirement	Supplemental Information
Line Voltage	115 VAC (90 to 132 VAC), 45 to 440Hz 230 VAC (180 to 250 VAC), 45 to 440Hz 12 VDC through battery pack connector	Fused at 0.3A  Fused at 0.15A
Battery Pack Operation	5 hours minimum, 20 chart recordings maximum.	15° C to 25° C charge and discharge temp. LCD backlight turned off. Opera- tion of instrument with backlight on, or at temperatures below 10° C, will degrade battery operation specification.
Full Charge Time		20 hours maximum
Overcharge Protection		Limited to 10 days of continuous charge. Battery will charge whenever instrument is plugged in. Battery may be removed during AC operation.
Discharge protection		Operation terminates prior to cell rever- sal
Typical Charge Capacity		2 amp/hours
Battery Charge Indicator		"Bat/low" will be indicated on the LCD when capacity reaches approx 10%
Temperature Operating	-10° C to +55° C	Battery capacity reduced at other than 15° C to 25° C.
Non-operating	-62° C to +85° C.	With battery pack removed. Storage temp with battery pack is -20° C to +55° C. Contents on non-volatile memory (stored waveform) may be lost at tem- peratures below -40°C.

**Table 1-2  
ENVIRONMENTAL CHARACTERISTICS**

<b>Characteristic</b>	<b>Performance Requirement</b>	<b>Supplemental Information</b>
Humidity	To 100%	Internal desiccant
Altitude		
Operating	To 15,000 feet	Mil-T-28800C, Class 3
Non-operating	To 40,000 feet	
Vibration	5 to 15Hz, 0.06 inch peak-to-peak 15 to 25Hz, 0.04 inch peak-to-peak 25 to 55Hz, 0.013 inch peak-to-peak	Mil-T-28800C, Class 3
Shock, Mech		
Pulse	30g, 1 ms 1/2 sine waveform Total of 18 shocks	Mil-T-28800C, Class 3
Bench Handling		Mil-Std -810, Method 516 Procedure V
Operating	4 drops each face at 4 inches or 45° with opposite edge as pivot.	Cabinet off, front cover on
Non-operating	4 drops each face at 4 inches or 45° with opposite edge as pivot. Satisfactory operation after drops.	Cabinet off, front cover off
Loose Cargo Bounce	1 inch double-amplitude orbital path at 5 Hz, 6 faces	Mil-Std-810, Method 514, Procedure XI, Part 2
Water Resistance		Mil-T-28800C, Style A
Operating	Splash-proof and drip-proof	Front cover off
Non-operating	Watertight with three feet of water above top of case	Front cover On
Salt Atmosphere	Withstand 48 hours, 20% solution without corrosion	

Table 1-2  
**ENVIRONMENTAL CHARACTERISTICS (con't)**

Characteristic	Performance Requirement	Supplemental Information
Sand and Dust	Operates after test with cover on, non-operating	Mil-Std-810, Method 510 Procedure I
Washability	Capable of being washed	
Electromagnetic Comp	VDE 0871 ClassB	
Fungus Inert	Materials are fungus inert	

Table 1-3  
**PHYSICAL CHARACTERISTICS**

Characteristic	Description
Weight	
Without Cover	14.25 lb
With cover	15.75 lb
With cover, YT-1 Chart Recorder and Battery Pack	19.75 lb
Shipping Weight	
Domestic	25.5 lb
Export	25.5 lb
Height	5.0 inches
Width	
With handle	12.4 inches
Without handle	11.8 inches
Depth	
With cover	16.5 inches
With handle extended	18.7 inches

## PERFORMANCE CHECK

The purpose of this procedure is make sure that the instrument is in good working condition and should be performed upon receipt of a new instrument or one that has been serviced or repaired. It does not test all portions of the instrument to Calibration specifications.

The purpose of this procedure is not to familiarize a new user with the instrument. If you are not experienced with the instrument you should read the *Operator Section* of this manual before going on with these checks.

If the instrument fails any of these tests, it should be serviced. Many failure modes affect only some of the instruments functions.

### Equipment Required

ITEM	Tektronix P/N
50 $\Omega$ precision terminator	011-0123-00
3 foot precision coaxial cable	012-0482-00

### Getting Ready

Disconnect any cables from the front panel CABLE connector. Connect the instrument to a suitable power source (a fully charged optional battery pack or AC line source). If you are using AC power make sure the fuse and power switch are correct for the voltage you are using (115 volts requires a different fuse than used for 230 volts).

### POWER On

Pull POWER switch on the front panel. If a message does not appear on the display within a second or two, turn the instrument off. There are some failure modes that could permanently damage or ruin the LCD if the power is left on for more than a minute or so. Refer to the troubleshooting section of this manual (*1502B Operator - Maintenance*).

### Metric Instruments

On Option 5 (METRIC) instruments, you can change the ft/DIV scale to metric in the "Set Up" menu, or use the metric numbers provided. To change the readings to metric, press **MENU**. Using the  $\blacktriangleleft$  POSITION control, scroll down to "Setup Menu" and press **MENU**. Scroll down to "Distance/Div is: ft/div" and press **MENU**. Menu will change to "Distance/Div is: m/div". Exit by pressing **MENU** until instrument returns to Normal Operation. If the instrument power is turned off, this procedure must be repeated when the instrument is powered up.

### Set Up

- Set the 1502B front panel:
 

NOISE FILTER	1 avg
VERT SCALE	No adjustment
DIST/DIV	1 ft/div
<i>DIST/DIV (METRIC)</i>	<i>.25m</i>
V <sub>p</sub>	.66
- Turn off the instrument.

1. Horizontal Scale (Timebase) Check

If the instrument fails this test it must be repaired before any distance measurements are made with it.

A. Turn on the instrument. The display should look very similar to the figure on the right.

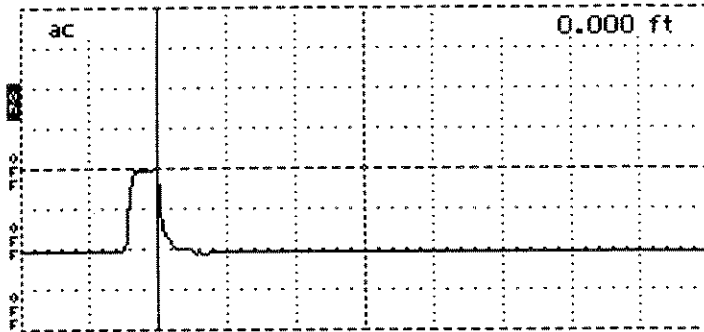

B. Connect the three foot precision cable to the front panel CABLE connector. The display should look like the figure on the right.

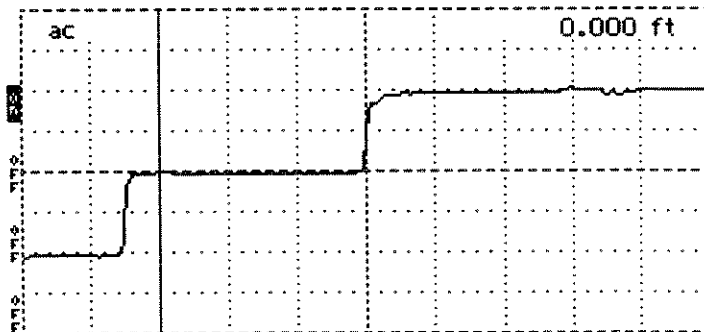

C. Using the  $\Phi$ POSITION control measure the distance to the rising edge of the waveform at the open end of the cable. The distance shown on the display distance window should read from 2.890 to 3.110 feet (METRIC - 0.901 to 0.927 metres).

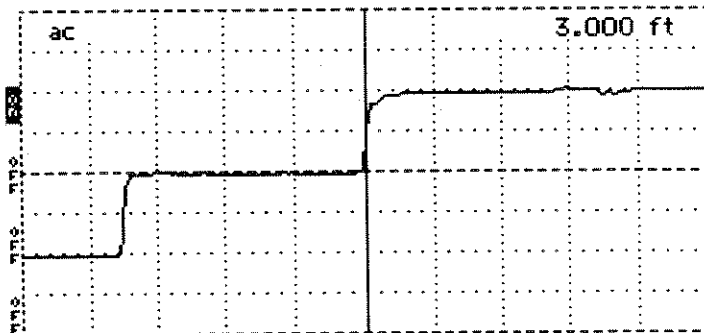

D. Change  $V_p$  to .30. Using the  $\Phi$ POSITION control measure the distance to the rising edge of the waveform at the open end of the cable. The distance shown on the display distance window should read from 1.320 to 1.400 feet (METRIC - 0.401 to 0.427 metres).

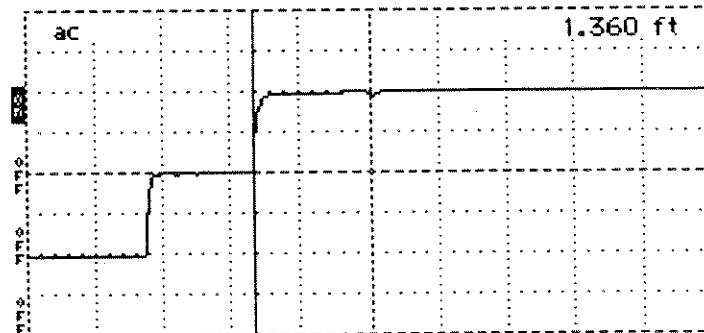

- E. Remove the three foot cable and connect the 50 terminator. Set the **DIST/DIV** control to 200 ft/DIV (*METRIC - 50 m/DIV*). Turn the **POSITION** control clockwise until the display distance window reads a distance greater than 2000.000 ft (*METRIC - 600 metres*). The waveform should remain a flat line from zero feet to this distance.

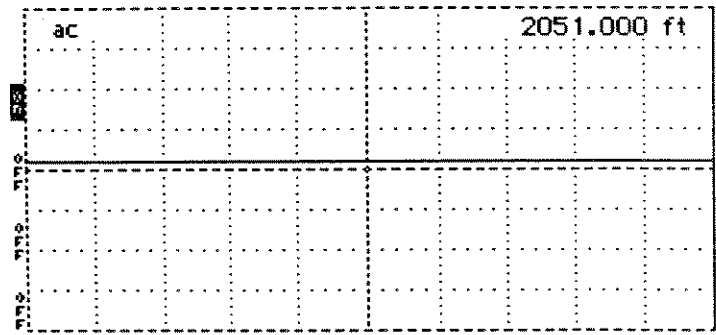

- F. Turn the **POSITION** control counterclockwise until the display distance window reads less than 10.000 ft (*METRIC - 3.1 metres*). Set the **DIST/DIV** control to .1 ft/DIV (*METRIC - 0.025 m/DIV*). Turn the **POSITION** control counterclockwise until the display distance window reads -2.000 ft (*METRIC - -0.611 metres*). This last step sets up the instrument for the next check.

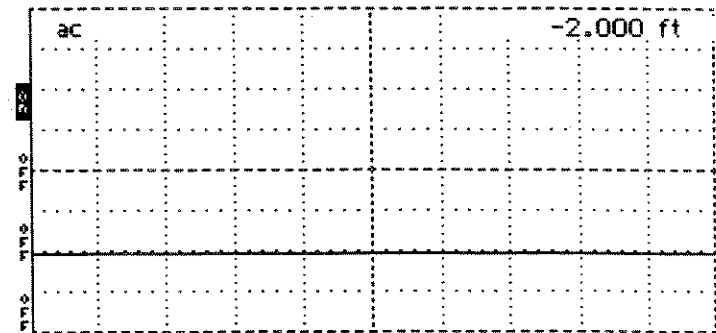

**2. Vertical Position (Offset) Check**

If the instrument fails only this test it can be used but should be serviced. Not all of the waveform will be viewable at all gain settings.

- A. Using the **POSITION** control, verify that the entire waveform can be moved to the very top of the display (off the graticule area).

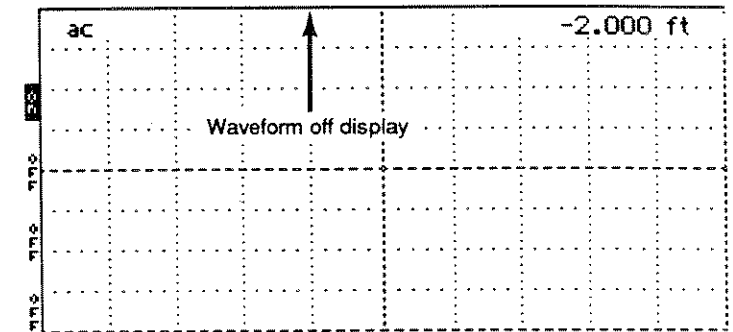

- B. Using the **POSITION** control, verify that the entire waveform can be moved to the very bottom of the display (to the bottom graticule line).

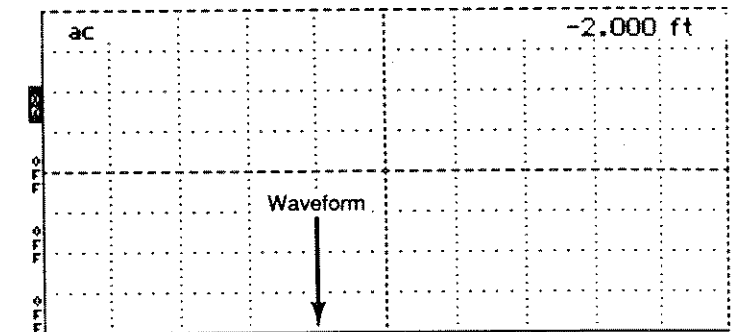

### 3. Noise Check

If the instrument fails this test it may still be usable for measurements of large faults that do not require a lot of gain. A great deal of noise reduction can be made using the NOISE FILTER control.

A. Adjust the  $\diamond$  POSITION control to obtain 100.000 ft on the display.

B. Using both the  $\diamond$  POSITION and VERT SCALE controls, set the gain to 5.00 mp/DIV. Keep the waveform centered vertically in the display.

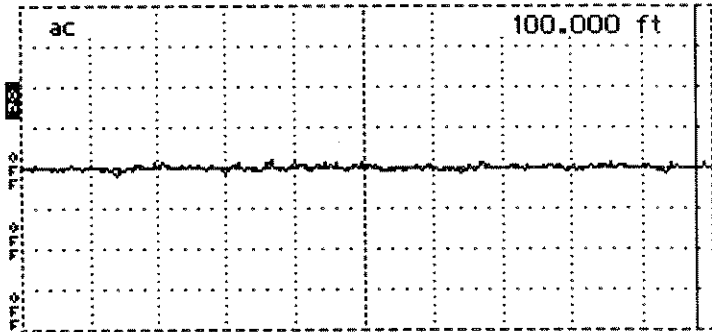

C. Press MENU and using the  $\diamond$  POSITION control, select "Diagnostics Menu" and press MENU. Using the same procedure with the  $\diamond$  POSITION control, select "Service Diagnostic Menu, select "Noise Diagnostic" and follow the directions on the display.

D. Do not exit from the "Service Diagnostic Menu" yet!



**4. Offset/Gain Check**

If the instrument fails this test, it should not be used for loss or impedance measurements.

- A. In the "Service Diagnostic Menu" select the "Offset/Gain Diagnostic" and follow the directions on the display.
- B. There are three screens of data presented in this diagnostic. The Pass/Fail level is 3% for any single gain setting tested.
- C. Do not leave the Service Diagnostic Menu yet!

**5. Sampling Efficiency Check**

If the instrument fails this test, the waveforms may not look normal. If the efficiency is more than 100%, the waveforms will appear noisy. If the efficiency is below the lower limit, the waveform will take longer (more pixels) to move from the bottom to the top of a reflected pulse. This smoothing effect may completely hide some faults that would normally only be one or two pixels wide on the display.

- A. In the "Service Diagnostic Menu" select the "Sampling Efficiency" test and follow the directions on the screen.
- B. When done with the test, press the **MENU** button to exit back to Normal Operation.

6. Aberrations Check

If the aberrations are out of specification, the ohms-at-cursor function should may be less accurate than specified.

A. Connect the 50Ω precision terminator to the front panel. Set the DIST/DIV control to 5 ft/DIV (*METRIC - 1 m/DIV*).

B. Increase the VERT SCALE control to 50 mp and move the top of the pulse to the center graticule line with the  $\Phi$  POSITION control.

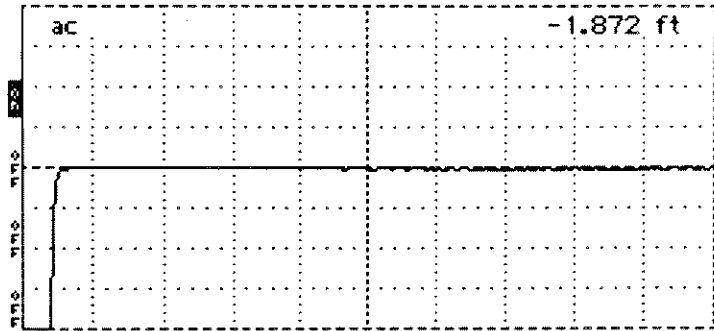

C. Set the DIST/DIV control to 0.2 ft/DIV (*METRIC - 0.05 metres*) and turn the  $\Phi$  POSITION control clockwise until the rising edge of the incident pulse is in the left-most major division on the display.

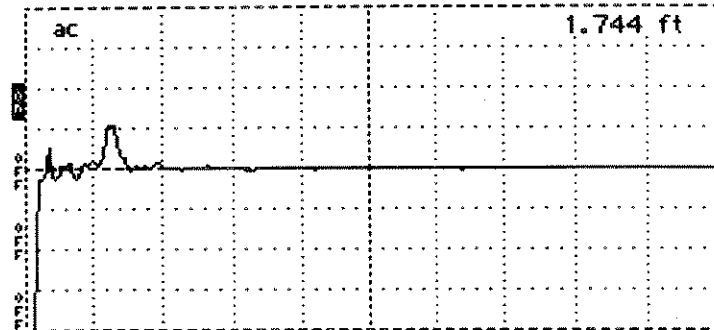

D. Move the cursor back to 0.000 ft/DIV (*METRIC - 0.00 m/DIV*) by turning the  $\Phi$  POSITION control counterclockwise. All the aberrations except the one under the cursor must be within one division of the center graticule line out to 10 feet past the rising edge of the pulse.

To verify distances past the right edge of the display scroll along the waveform by turning the  $\Phi$  POSITION control clockwise.

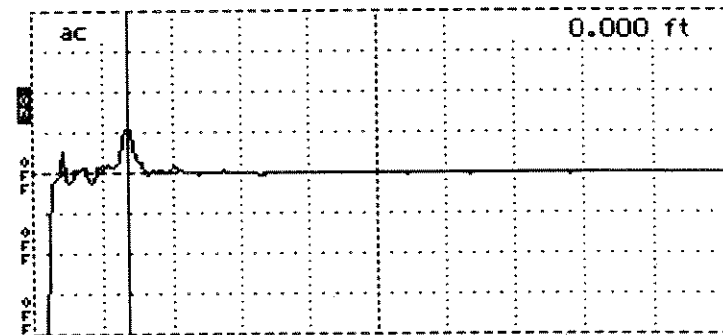

**7. Risetime Check**

If the risetime is out of specification, it may be difficult to make accurate short distance measurements near the front panel.

**A. Set the 1502B front panel:**

NOISE FILTER	1 avg
VERT SCALE	500 mp/DIV
V <sub>p</sub>	.99
DIST/DIV	0.2 ft/DIV
DIST/DIV (METRIC)	0.05 metres

**B. Using the POSITION control, move the incident pulse to the center of the display as shown.**

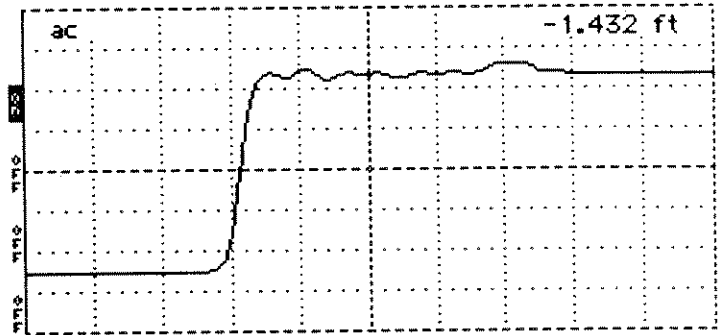

**C. Turn the VERT SCALE control clockwise until the leading edge of the incident pulse is five major divisions high (about 205 mp). Position the waveform so that it is centered about the middle graticule line.**

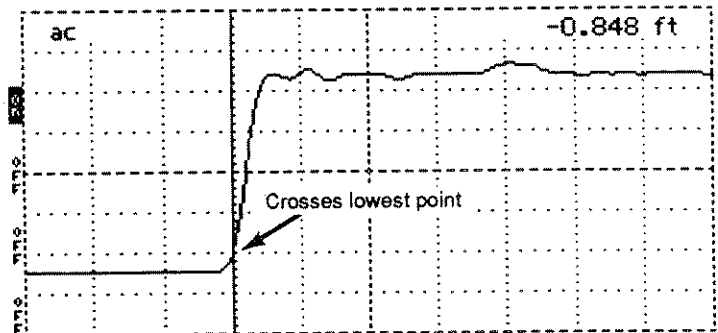

**D. Using the POSITION control, and the distances in the display distance window, verify that the distance between the points where the leading edge crosses the highest and lowest major division graticule lines is less than or equal to .096 ft (METRIC - 0.029 m).**

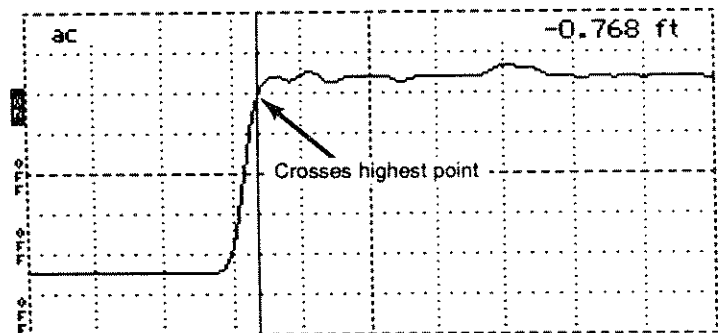

### 8. Jitter Check

Jitter is uncertainty in the timebase. Its main effect is that the waveform appears to move back and forth a very small amount. If the jitter is too great, it will effect the repeatability of very precise distance measurements.

- A. Set **VERT SCALE** clockwise for a setting of less than 1.0 mp/DIV. Verify that the leading edge of the pulse moves less than five pixels, or 0.02 ft (*METRIC - 0.006 m*).

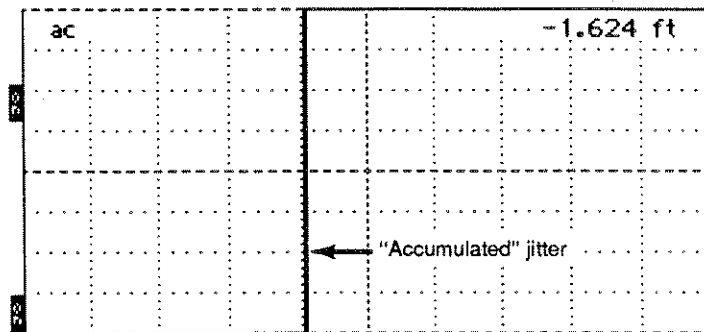
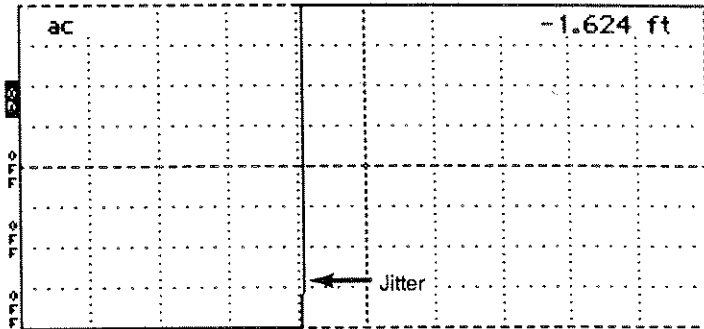

Using the Max Hold function (accessed in the "Setup Menu" under "Acquisition Control") can simplify this measurement for you.

### Conclusions

If the instrument failed Jitter or Risetime tests, it is probably still adequate for all but extremely precise distance measurements. If it failed the Horizontal Scale test, you should not use the instrument until the cause of the failure has been identified and corrected.

All of the previous tests only verify the major functional blocks of the instrument that could prevent you from being able to make measurements. It is possible for the front panel controls or the LCD to have problems that would also interfere with controlling or displaying measurements. Most problems of this type would become evident to you as you performed the tests above. If you suspect a problem of this nature, you should have the instrument serviced (or refer to the use of the diagnostics in the *1502B Service Manual* that cover these portions of the instrument).

If the instrument passed all of the checks above, it is ready for use.



# ACCESSORIES

## Standard Accessories (included with instrument)

Fig.	Accessory	Tektronix Part Number
1	1 Replacement Fuse (for AC line)	159-0029-01 (for 115 VAC) or 159-0054-00 (for 230 VAC)
2	1 Power Cord (outdoor rated)	161-0228-00
3	1 Option Port Cover Assembly	200-3497-00
4	1 Battery Pack Port Cover	200-3452-00
5	1 Precision 50 $\Omega$ Cable	012-0482-00
6	1 50 $\Omega$ BNC Terminator	011-0123-00
7	1 BNC Connector, Female-to-Female	103-0028-00
8	1 Calculator Slide Rule	003-0700-00
	1 Slide Rule Application Note	062-8344-00
	1 Accessory Pouch	016-0814-00
	1 Operator Manual	070-6266-00

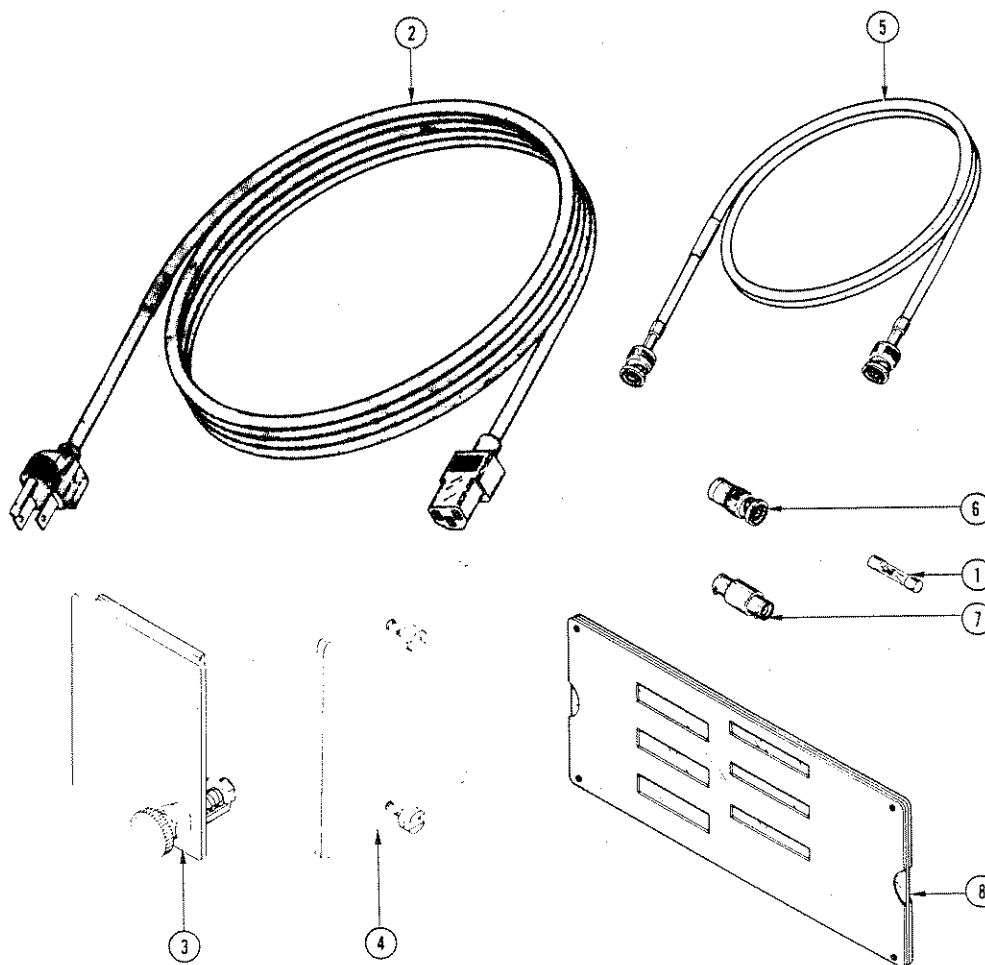

### OPTIONAL ACCESSORIES

Accessory	Tek Part No.
Instruction (Service) Manual	070-6267-00
Battery Pack	016-0813-00
Chart Recorder	YT1
Chart paper, single roll	006-7647-00
Chart paper, 25-roll quantity	006-7677-00
Chart paper, 100-roll quantity	006-7681-00
Connector, BNC Male to BNC Male	103-0029-00
Connector, BNC Female to Alligator Clips	013-0076-00
Connector, BNC Female to Hook-tip Leads	013-0076-01
Connector, BNC Female to Dual Banana Plug	103-0090-00
Connector, BNC Male to Dual Binding Post	103-0035-00
Connector, BNC Male to N Female	103-0058-00
Connector, BNC Female to N Male	103-0045-00
Connector, BNC Female to UHF Male	103-0015-00
Connector, BNC Female to UHF Female	103-0032-00
Connector, BNC Female to Type F Male	103-0158-00
Connector, BNC Male to Type F Female	013-0126-00
Connector, BNC Female to GR	017-0063-00
Connector, BNC Male to GR	017-0064-00
Terminator, 75 $\Omega$ BNC	011-0102-00
Adapter, Direct Current	015-0327-00
*Adapter, 50/75 $\Omega$	017-0091-00
*Adapter, 50/93 $\Omega$	017-0092-00
*Adapter, 50/125 $\Omega$	017-0090-00

\*Should be purchased with 017-0063-00 and 017-0064-00.



## OPTIONS

The following options are available for the 1502B TDR:

### OPTION 03 - Battery Pack

Instrument comes equipped with nickel-cadmium rechargeable battery pack.

#### Battery Pack Removal



*Read the instructions in the front of this manual in the Operator Section concerning the safety precautions necessary when charging, removing, or servicing the battery pack.*

1. Loosen the two knurled screws on the battery pack and pull back to remove from the rear panel of the instrument.
2. Replace in the same manner. Check that the battery pack banana sockets are aligned correctly with the battery pack port banana plugs. Push the battery pack directly into the compartment and tighten the two screws finger tight.
3. If removing the battery for any length of time, seal the battery pack port with the battery port cover. This will help seal the instrument from dirt and moisture.

### OPTION 04 - YT1 Chart Recorder

#### Instructions for Use

Making permanent records with the 1502B is easy with the Tektronix YT1 Digital Chart Recorder.

1. Make sure the desired waveform (or waveforms) is displayed on the LCD.
2. Slide back the protective cover on the recorder. Push **PRINT** on the front panel of the chart recorder.
3. When the chart recorder has finished, tear off the paper recording, pulling the paper to the left.

#### YT1 Chart Recorder Paper Replacement

1. Turn the knurled knob on the front panel of the chart recorder counterclockwise until it loosens. Pull the unit from the instrument. Set the instrument with the front panel to the right.
2. With your thumbs, push the frame surrounding the motor pulley. Push until the motor assembly latch locks the motor assembly to the side frame. This loosens the tension in the paper path, allowing any remaining paper to be removed.
3. Remove the paper retaining knob. Remove any paper and the empty paper core.
4. Following the diagram on the top of the recorder, place a fresh roll of paper in the recorder so the paper unwinds off the right side of the roll into the paper path (looking down on the recorder, the paper unrolls clockwise). Tearing the end of the paper roll on a slant will facilitate placing the paper in the slot.
5. Assure that the paper drops down into the paper path without binding, and the paper protrudes through the slot in the front of the instrument. Release the keeper from the frame, and the paper drive mechanism will return to the operating position.

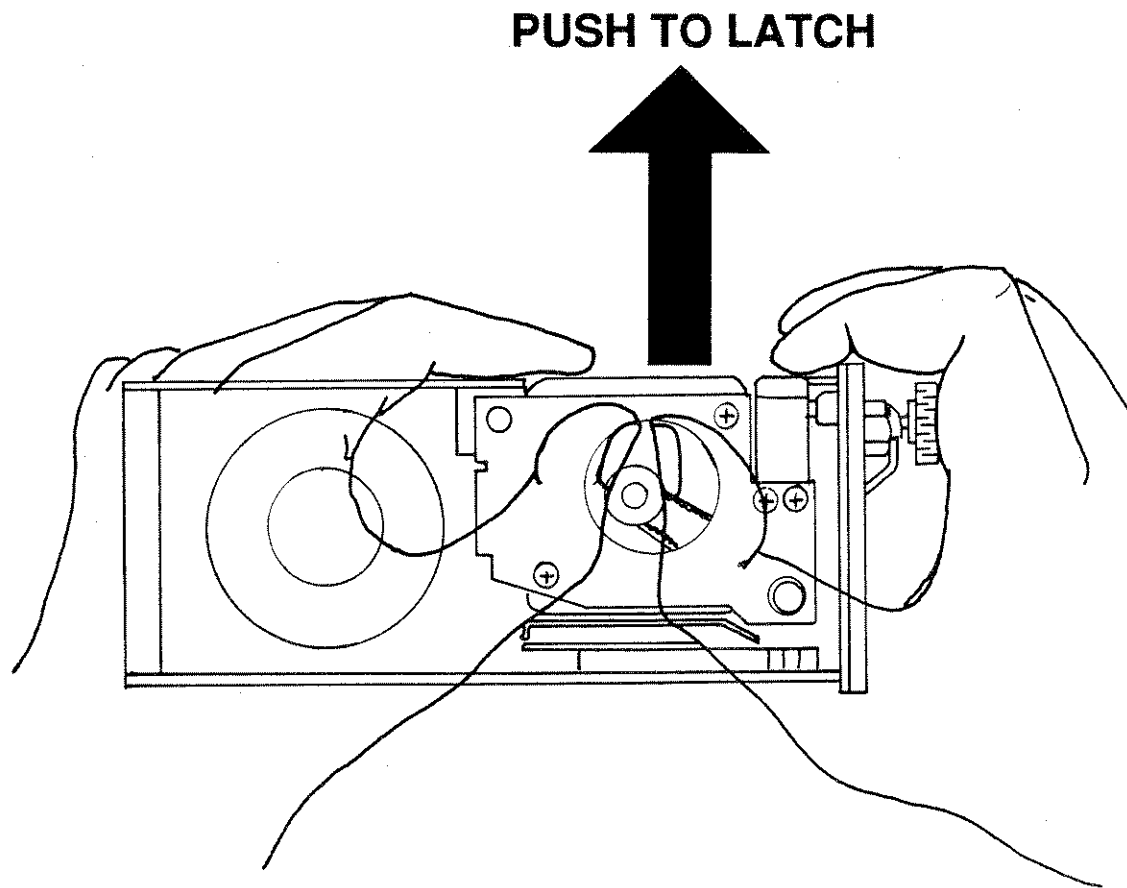

Paper Replacement

**OPTION 5 - Metric Default**

Instrument will power up in the metric mode. See *1502B Service Manual*.

**POWER CORD OPTIONS**

The following power cords are available for the 1502B TDR. Options require inserting 0.15 A fuses in the rear panel fuse holder.

*NOTE: The only power cord rated for outdoor use is the standard cord (161-0228-00) included with instruments (if not otherwise specified). All other optional power cords are rated for indoor use only.*

- |  |             |
|--|-------------|
| Option A1: 220 V/16 A - Universal Europe | 161-0066-09 |
| Option A2: 240 V/13 A - United Kingdom   | 161-0066-10 |
| Option A3: 240 V/10 A - Australia        | 161-0066-11 |
| Option A4: 240 V/15 A - North America    | 161-0066-12 |
| Option A5: 240 V/6 A - Switzerland       | 161-0154-00 |

## Pulse Echo Testing of Electrical Transmission Lines Using the Tektronix Time Domain Reflectometry Slide Rule

### Introduction

Most people who make quantitative reflectometry tests or measurements should find the Tektronix TDR slide rule helpful. Those new to the subject will find the slide rule graphically summarizes a wealth of information on reflectometry.

- VSWR versus Percent Reflected Voltage
- Return Loss, dB, versus Percent Reflected Voltage
- Percent Reflected Voltage, ( $\rho$ ) versus Characteristic Line Impedance, ( $Z_o$ ), for either 50- or 75  $\Omega$  source.
- Percent Reflected Voltage ( $\rho$ ), versus Load Resistance ( $R_L$ ), for either 50- or 75  $\Omega$  source.
- $Z_o$  or  $R_L$  versus Reflection Amplitude as seen on your Reflectometer.
- Dielectric Constant versus Velocity Factor.
- Time versus Short Distances in Centimeters or Inches, any dielectric
- Time versus Long Distances in Meters or Feet, any dielectric.

## Terms and Symbols

$R_s$	is	Source Resistance, of a signal generator
$Z_s$	is	Source Impedance, of a signal generator
$Z_0$	is	Characteristic Impedance, of a transmission line
$Z_L$	is	Load Impedance, for a transmission line
$R_L$	is	Load Resistance, for a transmission line
$\rho$	is	Reflection Coefficient (rho), the ratio of incident to reflected voltage.
mp	is	Reflection Coefficient divided by 1000 (milli-rho)
%	is	Ratio of incident to reflected voltage times 100
VSWR	is	Voltage Standing Wave Ratio (peak-to-Valley ratio)
c	is	Velocity of light in air
V	is	Propagation Velocity of a signal in a transmission line
$V_f$	is	Velocity Factor (fraction of velocity of light)
$\kappa$	is	Dielectric Constant
D	is	the outer diameter of the dielectric in a coaxial cable
d	is	the diameter of the center conductor in a coaxial cable
L	is	inductance in nanohenries per foot
C	is	capacitance in picofarads per foot

## Relationships

Z	=	$(138/\sqrt{\kappa}) \times (\log_{10} D/d)$ for a coaxial cable
% $\rho$	=	$\rho \times 100$
VSWR	=	$(1+\rho) + (1-\rho)$ for the case where VSWR is the same for all frequencies
c	=	30 cm per nanosecond = .984 feet per nanosecond
$V_f$	=	$1/\sqrt{\kappa}$
$V$	=	$30/\sqrt{\kappa}$ centimeters per nanosecond = $.984/\sqrt{\kappa}$ feet per nanosecond
$C^p$	=	$7.36\kappa + (\log_{10} D/d)$
L	=	$140 \log_{10} D/d$
1 inch	=	2.54 cm
1 foot	=	30.48 cm
1 meter	=	3.28 feet

Copyright © 1986, Tektronix, Inc. All rights reserved. Printed in U.S.A.  
 U.S.A. and Foreign Products of Tektronix, Inc. are covered by U.S.A. and Foreign Patents and/or Patents Pending.

TEKTRONIX, SCOPEMOBILE, TELEQUIPMENT, and  are registered trademarks of Tektronix, Inc.

### VSWR versus Percent Reflected Voltage

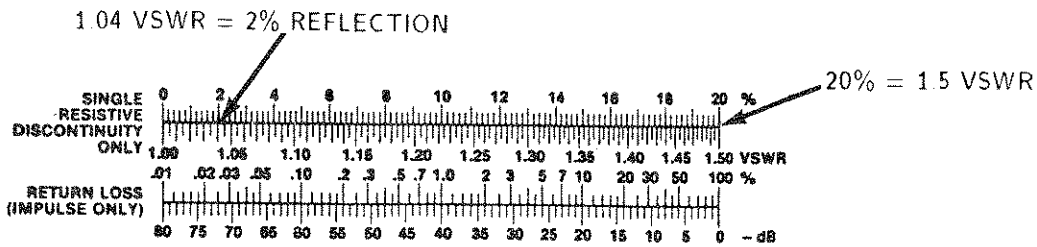

To find the Voltage Standing Wave Ratio, VSWR, knowing the percent reflected voltage (or vice versa), use the Frequency Domain Conversions section on the slide rule. (See above figure). On the upper scale locate the known value of VSWR (% of reflected voltage). Adjacent to that point is the corresponding value for % or VSWR. VSWR is the peak-to-valley ratio of standing sinewaves. Note: This relationship between % and VSWR holds only when the loss is a single impedance discontinuity with negligible capacitive or inductive components. For example, a 75-ohm termination at the end of a 50-ohm cable. Another way to express the same caution is to say the VSWR must be essentially the same for all sinewave frequencies for the relationship to be valid.

### Return Loss, dB, versus Percent Reflected Voltage

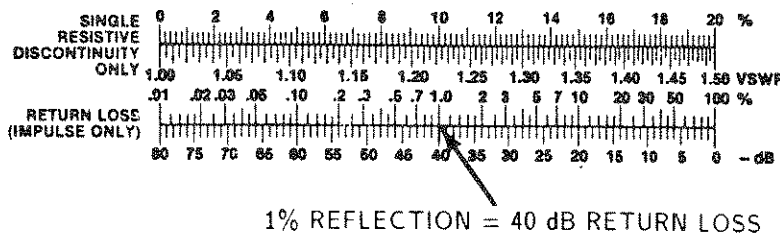

To find return loss in decibels knowing the percent reflected voltage (or vice versa) use the bottom scale of the Frequency Domain Conversions section of the slide rule (above illustration). Locate the known value of percent reflected voltage or the known dB return loss and locate the value of the corresponding expression on the adjacent scale. Note: Only the impulse mode of Time Domain Reflectometry may be accurately expressed in terms of return loss. Also keep in mind that a narrow impulse will be attenuated by losses in the cable and reflections will be attenuated likewise.

As with measurements on VSWR there is only a simple mathematical relationship between reflection measurements using sinewaves and reflection measurements using pulses when one resistive discontinuity is the whole cause for the sizable reflections.

Percent Reflected Voltage ( $\rho$ ) versus characteristic Line Impedance ( $Z_0$ ), for either 50-ohm or 75-ohm Source.

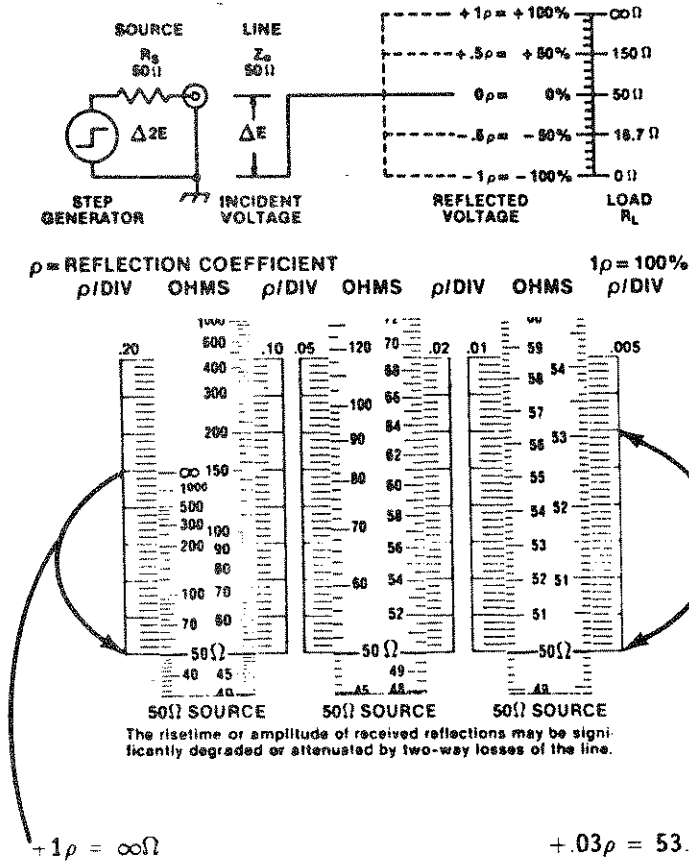

To find the characteristic impedance of a line or section of a line knowing the reflection coefficient,  $\rho$ , or the percent reflected voltage, you should first know the impedance of the pulse generator. It should be as close as possible to the nominal impedance of the line and be connected to the line through a length of cable having the same impedance as the source. Select the side of the slide rule that corresponds to the source resistance ( $R_s$ ) of the generator used then select the longest scale this way:

Size of Reflection	%/Div	$\rho/DIV$
100% to 80% ( $1\rho$ to $.8\rho$ )	20%/DIV	$2\rho/DIV$
80% to 40% ( $.8\rho$ to $.4\rho$ )	10%/DIV	$1\rho/DIV$
40% to 16% ( $.4\rho$ to $.16\rho$ )	5%/DIV	$.05\rho/DIV$
16% to 8% ( $.16\rho$ to $.08\rho$ )	2%/DIV	$.02\rho/DIV$
8% to 4% ( $.08\rho$ to $.04\rho$ )	1%/DIV	$.01\rho/DIV$
4% or less ( $< .04\rho$ )	.5%/DIV	$.005\rho/DIV$

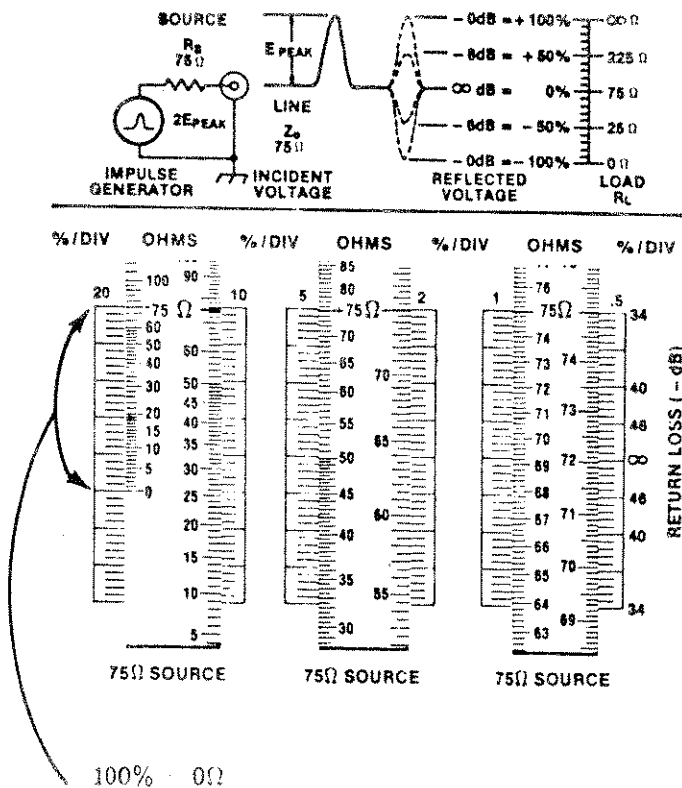

If the reflection is downward from the 50-ohm (or 75-ohm) reference level, set the reference level to the top of the chosen scale. If the reflection is toward a higher impedance than the reference level, set the reference level to the bottom of the chosen scale. Then count off the right number of divisions and subdivisions to locate the level corresponding to the peak of the reflection and read the corresponding impedance level (ohms) on the adjacent sliding scale.

If the line impedance and the source resistance is known, the expected amplitude of a reflection can be approximated. First, select the side of the slide rule having the right source impedance. For cables having a higher impedance than the selected source resistance, put the sliding reference level even with the bottom stationary scale markings. For cables having a lower impedance than the selected source resistance, move the reference level even with the top of the scale markings. For best accuracy select the scale farthest to your right in which the impedance level (ohms) of interest is within view. Read from the adjacent stationary scale the Reflection Coefficient or Percent Reflected Voltage that corresponds to the ohms selected.

### Percent Reflected Voltage ( $\rho$ ) versus Load Resistance ( $R_L$ ), for either 50- or 75- $\Omega$ Source.

To find the terminating load resistance ( $R_L$ ) of a line knowing the percent reflected voltage or reflection coefficient use preceding instructions.

If the load resistance is known, the previous procedure may be used to approximate the size of the return reflection. An error may be introduced if the impedance of the connecting cable does not match the source resistance of the pulse generator.

## $Z_o$ or $R_L$ versus Reflection Amplitude as seen on your Reflectometer

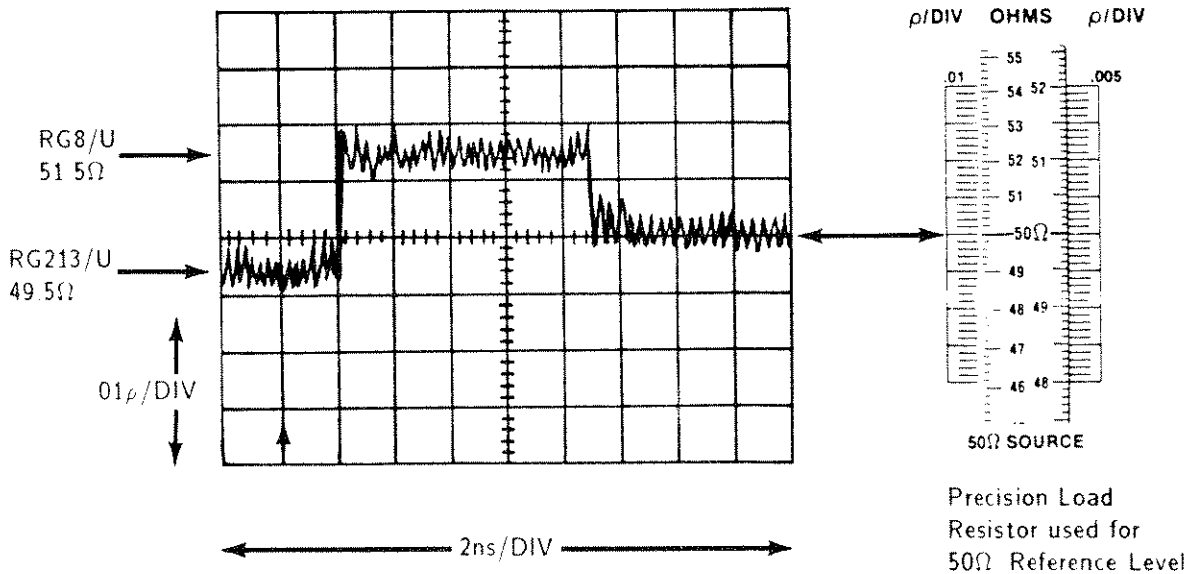

Line Impedance ( $Z_o$ ) or Load Resistance ( $R_L$ ) may be derived directly from the amplitude of a reflection displayed on a TDR CRT. The displayed reflection should first be positioned vertically to a known 50-ohm reference level. For a reference level use either a section of line of known impedance ahead of the line or load under test, or use a termination of known resistance at the end of the line. The slide rule may then be used by selecting the side with the same source resistance and the same scale as the reflectometer. Position the 50-ohm (or 75-ohm) reference level on the sliding scale corresponding to the one selected for the reference level in the display. The impedance (ohms) causing the reflection may then be read from the sliding scale by noting the position on the fixed scale corresponding to the position of the reflection in the TDR display.

You should note that the peak level of any reflection that does not have a discernible plateau may be an erroneous indication of the impedance discontinuity that caused it. There may be several reasons for the error. First, the discontinuity may occupy such a short section segment of the line, compared to the propagation velocity of the line and the risetime of the test pulse wavefront that part of the wavefront starts to emerge from the segment while the remainder is still entering. This causes a spike-shaped reflection, the amplitude of which may vary depending on the risetime of the test pulse, how badly the risetime may have been degraded by the cable before it arrives, and how much attenuation the cable may impose on the reflection before it arrives back at the source. Secondly, if the risetime of the TDR system is too long, a reflection with a plateau will appear as a spike.



## Centimeters versus Inches, or Meters versus Feet

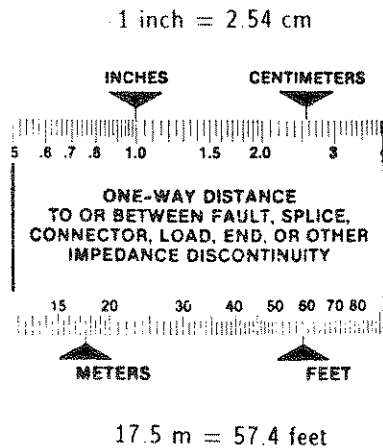

**INCHES** A given number of inches may be converted to centimeters by placing the point on the sliding scale that corresponds to that number next to the stationary arrow labeled *Inches* then reading the equivalent distance in centimeters next to the point of the arrow labeled *Centimeters*.

**CENTIMETERS** Centimeters are converted to inches in the opposite manner. Meters may be converted to feet and vice versa using the Meters and Feet scale in a similar way.

## Dielectric Constant versus Velocity Factor

Dielectric Constant and Velocity Factor appear on two identical scales next to a sliding scale labeled *Round Trip Time*. To find one knowing the other read directly across the sliding scale. Any major division on the sliding scale may be placed next to the known value to help read directly across the sliding scale.

## Time versus Short Distances, in Centimeters or Inches, any dielectric

*Dielectric is Air*

*Time = 200ps*

*Velocity Factor = 1*

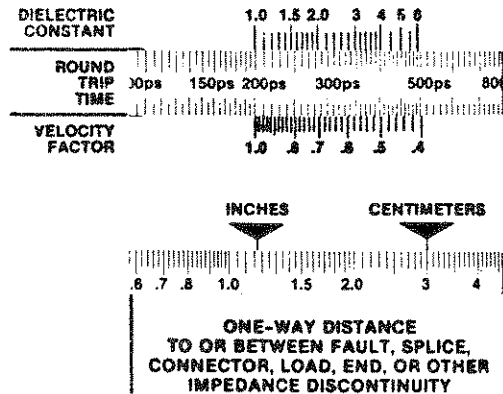

Distance is  
3.0 cm or 1.18 inches

To find the distances to or between discontinuities in a transmission line knowing the time for a pulse edge to travel the distance and back (round trip time) it is necessary to know either the dielectric constant of the material between the conductors or the velocity factor of the line. For distances less than about three meters or ten feet use the Centimeters and Inches scale. The round trip time should be located on the sliding scale that is located above the Centimeters and Inches scale. Place the point on the sliding scale next to a point on one of the stationary scales that corresponds to the value of the dielectric constant or velocity factor. Then read the distance on the Inches and Centimeters scale.

If the distance to or between faults is known and you wish to find the time or velocity factor set the distance under the appropriate arrow first.

Time versus Long Distances, in Meters or Feet, any dielectric.

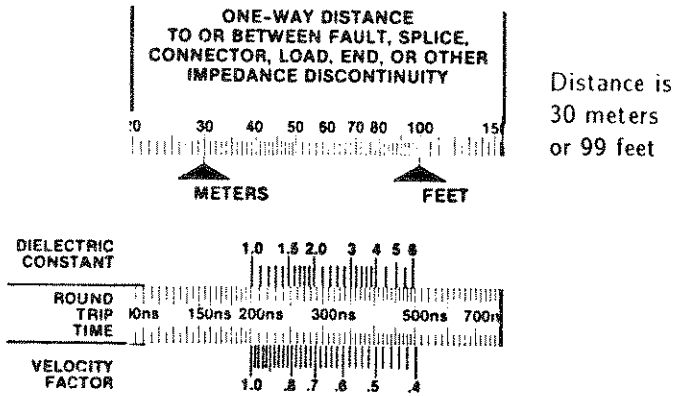

*Dielectric is Solid Polyethylene*

*Time = 300ns*

*Velocity Factor = .66*

Distances to or between discontinuities further apart than about three meters or ten feet may be found on the Meters and Feet scale. Use the sliding Round Trip Time scale just below it and follow the same procedure as above.

