

# 1750 SERIES

## WAVEFORM/VECTOR MONITORS

*Please Check for  
CHANGE INFORMATION  
at the Rear of This Manual*

First Printing MAY 1984  
Revised JUN 1987

**Tektronix**<sup>®</sup>  
COMMITTED TO EXCELLENCE

Copyright © 1984 Tektronix, Inc. All rights reserved.  
Contents of this publication may not be reproduced in any  
form without the written permission of Tektronix, Inc.

Products of Tektronix, Inc. and its subsidiaries are covered  
by U.S. and foreign patents and/or pending patents.

TEKTRONIX, TEK, SCOPE-MOBILE, and  are  
registered trademarks of Tektronix, Inc. TELEQUIPMENT  
is a registered trademark of Tektronix U.K. Limited.

Printed in U.S.A. Specification and price change privileges  
are reserved.

# PREFACE

This manual documents the TEKTRONIX 1750-Series Waveform/Vector Monitor. Information applying to all instruments in the series uses the term 1750-Series. Information that applies to a specific instrument, within the series, uses specific instrument type (i.e. 1750 or 1751).

The information in this manual is intended for instrument operators and service technicians. For purposes of classification, operators are assumed to be familiar with basic television concepts, while a qualified service technician is familiar with both the concepts of television and basic electronic servicing techniques.

The information contained here is also classified as to which user it is intended for. The Operator's Information is useful to both operators and service technicians, because it contains the general operating instructions. The Service Information, because of its intended purpose, is designed for qualified service technicians.

## PART I OPERATOR'S INFORMATION

Section 1, Introduction and Specification, includes a general description of the instrument followed by the Specification. The Specification includes references to corresponding Performance Check steps.

Section 2, Operating Instructions, in addition to the front and rear panel control and connector discussions, contains both application related discussions and a brief familiarization discussion.

## PART II SERVICE INFORMATION

This part of the manual contains the information required to install, calibrate, maintain, and troubleshoot the instrument.

Section 3, Installation, includes electrical and mechanical installation information, which includes power mains conversion, adjustments, remote connections, operational changes, and rackmounting instructions.

Section 4, Theory of Operation, provides an overall block description and detailed circuit descriptions.

Section 5, Checks and Adjustments, includes the Performance Check Procedure and the Adjustment Procedure. The Performance Check Procedure is used to verify instrument performance within its specifications, and the Adjustment Procedure is used to adjust the instrument within its specifications. The procedures are preceded by a list of recommended test equipment.

Section 6, Maintenance, includes preventive maintenance instructions, troubleshooting techniques (including a procedure), and corrective maintenance information.

Section 7, Replaceable Electrical Parts, includes ordering information and part numbers for all replaceable electrical parts.

Section 8, Diagrams, contains servicing illustrations. These include adjustment locations, circuit board parts locations, a block diagram, schematic diagrams, and waveforms. Parts locating tables are included that cross reference the circuit board illustrations and schematic diagrams.

Section 9, Replaceable Mechanical Parts, includes ordering information and part numbers for all replaceable mechanical parts. This parts list is referenced to an exploded-view mechanical drawing. Also included are lists of accessories and optional accessories.

# TABLE OF CONTENTS

	Page
Preface .....	i
List of Illustrations .....	v
List of Tables .....	vi
Operator's Safety Summary .....	vii

## PART I OPERATOR'S INFORMATION

<b>Section 1</b>	<b>INTRODUCTION AND SPECIFICATION</b>	
	Display Modes .....	1-1
	Waveform Mode .....	1-1
	R-Y or V AXIS Mode .....	1-2
	Vector Mode .....	1-2
	SCH Mode .....	1-2
	Combination Modes .....	1-2
	RGB/YRGB Display .....	1-3
	Bright CRT Display .....	1-3
	Remote Control Capability .....	1-3
	Accessories .....	1-3
	Safety Standards .....	1-3
	Specification .....	1-4
<b>Section 2</b>	<b>OPERATING INSTRUCTIONS</b>	
	Introduction .....	2-1
	Controls, Indicators, and Connectors .....	2-1
	Front-Panel Controls and Indicators .....	2-1
	Rear-Panel Connectors and Switch .....	2-4
	Operator's Checkout Procedure .....	2-5
	Application Information .....	2-11
	Signal Degradations .....	2-12
	SCH Phase .....	2-12
	Signal Timing .....	2-13
	Graticules .....	2-13
	Waveform Graticule .....	2-13
	NTSC and CCIR Horizontal Scales .....	2-13
	NTSC Vertical Scales (1750 Only) .....	2-14
	CCIR Vertical Scales (1751) ..	2-14
	CCIR K Factor Scales (1751) ..	2-14
	Vector Graticules .....	2-15
	NTSC Vector Targets (1750) ..	2-15
	PAL Vector Targets .....	2-15
	Bandwidth Calibration Aid .....	2-15
	Differential Gain and Phase Measurements .....	2-16

## Section 2 OPERATING INSTRUCTIONS (cont)

Differential Gain/Differential Phase Scales .....	2-16
R-Y (V-Axis) Scale .....	2-17
Waveform Mode Differential Gain Measurements .....	2-17
SCH Phase Measurements .....	2-17
Matching SCH Timing .....	2-17

**WARNING**

*THE FOLLOWING SERVICING INSTRUCTIONS ARE FOR USE BY QUALIFIED PERSONNEL ONLY. TO AVOID PERSONAL INJURY, DO NOT PERFORM ANY SERVICING OTHER THAN THAT CONTAINED IN OPERATING INSTRUCTIONS UNLESS YOU ARE QUALIFIED TO DO SO. REFER TO OPERATORS SAFETY SUMMARY AND SERVICE SAFETY SUMMARY PRIOR TO PERFORMING ANY SERVICE.*

## PART II SERVICE INFORMATION

SERVICE SAFETY SUMMARY .....	3-1	
<b>Section 3</b>	<b>INSTALLATION</b>	
	Packaging .....	3-1
	Accessories .....	3-1
	Electrical Installation .....	3-1
	Mains Frequency and Voltage Ranges .....	3-1
	Power Cord Options .....	3-2
	Mains Conversion .....	3-2
	Trace Rotation Adjustment .....	3-2
	Remote Connections .....	3-5
	Remote Front Panel .....	3-5
	Remote Line and Field Selection .....	3-7
	Operational Changes .....	3-10
	Altering Line Selector Operation (internally) .....	3-11
	Mechanical Installation .....	3-11
	Rackmounting .....	3-11
	Cooling .....	3-11
	Tektronix Part Numbers .....	3-12
	Optional Installation Accessories .....	3-12

# TABLE OF CONTENTS (cont)

<b>Section 4</b>	<b>THEORY OF OPERATION</b>		<b>Section 4</b>	<b>THEORY OF OPERATION (cont)</b>	
	Block Description .....	4-1		SCH VCXO's 7 .....	4-13
	Detailed Circuit Description .....	4-2		SCH Clock Generator .....	4-13
	Vertical Board (A3) .....	4-2		SCH I/O Latch .....	4-13
	Video Input 1 .....	4-2		SCH Intra-Line Decoding .....	4-13
	Inputs .....	4-2		Reference Clock Generator .....	4-13
	Calibrator .....	4-3		Reference I/O Latch .....	4-13
	Line Select Bright-up .....	4-3		Power Supplies .....	4-14
	Switching Logic .....	4-3		SCH Logic 8 .....	4-14
	Filters .....	4-3		Reference Intra-Line	
	Variable Gain Amp .....	4-4		Decoding .....	4-14
	Chroma Amp .....	4-4		Line Counter and Intra-Frame	
	Vertical Output 2 .....	4-4		Decoding .....	4-14
	DC Restorer .....	4-4		Sweep Gating .....	4-14
	DC-Restored Amplifier .....	4-4		Line Select .....	4-14
	Vertical Output Switch .....	4-4		Color Frame Identification .....	4-14
	Vertical Output Amplifier .....	4-5		Demodulator Source	
	Power Supplies .....	4-5		Selection .....	4-14
	Horizontal Board (A4) .....	4-5		Interface and HV Power Supply	
	Sync Clamp 3 .....	4-5		(A1); CRT Control (A7); Front	
	Sync Reference Switching .....	4-5		Panel (A8); and Low Voltage	
	SCH Locate (1 and 2) .....	4-6		Power Supply (A6) .....	4-15
	Power Supplies .....	4-6		HV and CRT 10 .....	4-15
	Sweep Generator and Horizontal			High Voltage Supply .....	4-15
	Output 4 .....	4-6		CRT Alignment .....	4-16
	Ramp and Mag Switching .....	4-6		Scale Illumination Control .....	4-16
	Sweep Generators .....	4-6		Intensity Control .....	4-16
	RGB/YRGB Staircase Input .....	4-6		Z Axis Output .....	4-16
	Horizontal Mag Amp .....	4-7		CRT Controls (A6),10 .....	4-16
	Offscreen Blanking .....	4-7		Front-Panel Signal Controls	
	Horizontal Output Amplifier .....	4-7		(A8),12 .....	4-16
	Demodulator Board (A5) .....	4-7		Interface and Remote 9 .....	4-16
	Subcarrier Regenerator 5 .....	4-7		Interface .....	4-16
	Phase Lock Loop Basic			Remote Control .....	4-16
	Operation .....	4-7		Low Voltage Power Supply (A6) .....	4-17
	Subcarrier Oscillator .....	4-8		Input and Line Rectifier .....	4-17
	Burst Amplifier .....	4-9		Switching Primary .....	4-17
	Burst Demodulator .....	4-9		Pulse Width Modulation .....	4-18
	Phase Lock Control .....	4-10		Start Up .....	4-18
	PAL Phase Lock Control			Filtered Outputs .....	4-18
	(1751 Only) .....	4-10			
	Chroma Source Switches .....	4-11			
	Chroma Amplifier .....	4-11			
	Chrominance Clamp .....	4-11			
	Center Dot Blanking .....	4-11			
	Power Supplies .....	4-11			
	Demodulator 6 .....	4-11			
	V Axis Switcher .....	4-11			
	Chroma Demodulators .....	4-12			
	Demodulator Output				
	Amplifiers .....	4-12			
	SCH Rephase .....	4-12			
	SCH Logic Board (A9) .....	4-12			
			<b>Section 5</b>	<b>CHECKS AND ADJUSTMENTS</b>	
				Recommended Equipment List .....	5-1
				Electrical Instruments .....	5-1
				Auxiliary Equipment .....	5-2
				Performance Check .....	5-4
				Performance Check Procedure .....	5-5
				Adjustment Procedure .....	5-15
				Short-Form Procedure .....	5-15
				Detailed Adjustment Procedure .....	5-17
				1750-Series Setup .....	5-17

# TABLE OF CONTENTS (cont)

<b>Section 6</b>	<b>MAINTENANCE</b>	
	Introduction .....	6-1
	Preventive Maintenance .....	6-1
	Cleaning .....	6-1
	Visual Inspection .....	6-1
	Static-Sensitive Components .....	6-1
	Performance Checks and Readjustment .....	6-2
	General Troubleshooting .....	6-2
	Troubleshooting Aids .....	6-2
	General Troubleshooting Technique .....	6-3
	Troubleshooting Procedure .....	6-5
	Starting Off .....	6-5
	1750-Series Setup .....	6-5
	Problem Symptom Survey .....	6-5
	Detailed Fault Isolation Procedures .....	6-7
	Horizontal Board (A4) .....	6-7
	Vertical Board (A3) .....	6-7
	Demodulator Board (A5) .....	6-8
	SCH Logic Board (A9) .....	6-9
	Signature Analysis .....	6-9
	Other Functions .....	6-10
	Corrective Maintenance .....	6-11
	Obtaining Replacement Parts .....	6-11
	Selected Components .....	6-11
	Mechanical Disassembly/Assembly .....	6-11
	Plug-In Circuit Board Removal .....	6-12
	Front-Panel Assembly (A8) Removal .....	6-12
	Graticule Light Removal .....	6-12
	Separating the Instrument .....	6-12
	Replacing the BNC Input Assembly (A2) .....	6-13
	LV Power Supply Board (A6) Removal .....	6-14
	Interface and HV Supply Board (A1) Removal .....	6-14
	Removing CRT Control Board (A7) .....	6-14
	CRT Removal .....	6-14
	Repackaging .....	6-16

# LIST OF ILLUSTRATIONS

Fig. No.		Page	Fig. No.		Page
1-1	Typical SCH Phase measurement displays	1-2	3-1	The various power cord options offered for the 1750-Series Waveform/Vector Monitor	3-2
1-2	IEEE 1972 Standard 205	1-14	3-2	Changing Line Selector switch	3-3
2-1	Front-panel controls and indicators	2-2	3-3	Trace Rotation Adjustment location	3-4
2-2	1750-Series rear panel	2-4	3-4	1750-Series Remote Plug pin assignments	3-5
2-3	Calibrator waveform displayed in WFM Mode	2-6	3-5	Location of the Line Selector Range switch	3-12
2-4	Color bar signal displayed with FLAT response	2-7	3-6	Installation of the 1750-Series in the side-by-side rack cabinet assembly	3-13
2-5	1750-Series Low Pass Luminance Filters	2-7	4-1	Simplified Block Diagram of the 1750-Series	4-1
2-6	Typical display when the Chrominance (CHROMA) Filter is used	2-7	4-2	Block diagram of the Phase Lock Loop	4-8
2-7	Color bar signal displayed in each of the sweep rates	2-8	4-3	Subcarrier Oscillator equivalent circuit	4-8
2-8	1 $\mu$ s/Div. display of H (line) sync. 2H SWEEP rate with the MAG on	2-8	4-4	Simplified schematic diagram of the Burst Demodulator	4-9
2-9	Display of color bar vectors	2-9	5-1	RGB parade display test connector	5-3
2-10	The +V display of the PAL color bar signal (1751 only)	2-10	5-2	Using triggered sinewaves to make timing measurements	5-7
2-11	Differential Phase measured in the R-Y (V-AXIS) Mode	2-10	5-3	DC Restorer 60 Hz hum response	5-9
2-12	Properly SCH Phased signal displayed on: A. 1750 B. 1751.	2-11	5-4	Checking Modulated Sine-Squared pulse response	5-10
2-13	PAL signal displayed in the V-AXIS Mode	2-11	5-5	Driving both CH A and CH B inputs with color bar signal	5-12
2-14	An example of SCH Phase extrapolation	2-13	5-6	Using triggered sinewaves to make timing measurements	5-19
2-15	An SCH Phase measurement of a signal containing a 40° error	2-13	5-7	Adjusting B-Y (U) gain	5-23
2-16	Waveform portion of the 1750-Series composite graticules	2-14	5-8	Driving both CH A and CH B inputs with color bar signal	5-24
2-17	Interpreting the vector graticule	2-15	6-1	Using the 1750-Series Instruction Manual fold-out pages	6-3
2-18	Interpreting a differential gain measurement	2-16	6-2	1750-Series assembly locations	6-4
2-19	Interpreting a differential phase measurement	2-16	6-3	Unlocked phase-locked loop error voltage	6-8
2-20	Typical SCH Phase display	2-17	6-4	Separating the instrument	6-13
2-21	Vector display along with the SCH Phase measurement display	2-17	6-5	Location of the four screws securing the crt assembly to the front panel	6-15
			6-6	Repackaging	6-16

# LIST OF TABLES

Table No.		Page
1-1	Electrical Characteristics .....	1-4
1-2	Environmental Characteristics .....	1-13
1-3	Certification .....	1-13
1-4	Physical Characteristics .....	1-14
3-1	Remote Front-Panel Switching .....	3-6
3-2	NTSC Remote Line and Field Selection ...	3-8
3-3	PAL Remote Line and Field Selection .....	3-9
6-1	Relative Susceptibility to Static Discharge Damage .....	6-2
6-2	1750 (NTSC) Signature Table .....	6-10
6-3	1751 (PAL) Signature Table .....	6-10
6-4	Recommended Service Items .....	6-16



# OPERATORS SAFETY SUMMARY

The general safety information in this part of the summary is for both operating and servicing personnel. Specific warnings and cautions will be found throughout the manual where they apply, but may not appear in this summary.

## TERMS

### In This Manual

**CAUTION** statements identify conditions or practices that could result in damage to the equipment or other property.

**WARNING** statements identify conditions or practices that could result in personal injury or loss of life.

### As Marked on Equipment

**CAUTION** indicates a personal injury hazard not immediately accessible as one reads the marking, or a hazard to property including the equipment itself.

**DANGER** indicates a personal injury hazard immediately accessible as one reads the marking.

### Power Source

This product is intended to operate from a power source that will not apply more than 250 volts rms between the supply conductors or between either supply conductor and ground.

### Grounding the Product

This product is grounded through the grounding conductor of the power module power cord. To avoid electrical shock, plug the power cord into a properly wired receptacle before connecting to the product input or output terminals. A protective ground connection by way of the grounding conductor in the power module power cord is essential for safe operation.

## SYMBOLS

### In This Manual



Symbol indicates where applicable cautionary or other information is to be found.

### As Marked on Equipment



**DANGER** — High voltage.



Protective ground (earth) terminal.



**ATTENTION** — refer to manual.

### Power Source

This product is intended to operate from a power source that will not apply more than 250 volts rms between the supply conductors or between either supply conductor and ground.

### Danger Arising From Loss of Ground

Upon loss of the protective-ground connection, all accessible conductive parts (including knobs and controls that may appear to be insulating) can render an electric shock.

### Use the Proper Fuse

To avoid fire hazard, use only the fuse of correct type, voltage rating and current rating as specified in the parts list for your product.

Refer fuse replacement to qualified service personnel.

### Do Not Operate in Explosive Atmospheres

To avoid explosion, do not operate this product in an explosive atmosphere unless it has been specifically certified for such operation.



4472-81

1750 and 1751 WAVEFORM/VECTOR MONITORS.

# PART 1

## OPERATOR'S INFORMATION

### INTRODUCTION AND SPECIFICATION

The 1750 (NTSC) and the 1751 (PAL) Waveform/Vector Monitors are comprehensive signal monitors that provide extended measurement capability. They are half-rack width by five and one-quarter inches high, which suits them for numerous side-by-side monitoring tasks with other half-rack instruments. Both the 1750 and the 1751 provide SCH Phase monitoring and measurement capability, along with front-panel line and field selection, and camera chain (RGB or YRGB) measurements.

The SCH Phase display of the 1750-Series monitors can be used to monitor SCH Phase, adjust SCH Phase (even from a distance and at wide viewing angles), and determine if the signal is exhibiting the correct color frame. The display, which consists of demodulated color burst vector(s), and a phase-locked horizontal sync dot is easily interpreted. When an external reference signal (composite video, black burst, or color black, that has little or no SCH Phase error) is used, a color framing error between signals can be determined.

The 1750-Series combines line and field selection with a bright crt, which makes it possible to look at a single line of the television field. Line and field selection can be either from the front panel or as a combination of front-panel and remote.

Demodulated chrominance can be displayed with a horizontal sweep using the R-Y Mode for NTSC or the V-Axis Mode for PAL signals. When burst phase is set properly in the Vector Mode, the R-Y Mode displays the chrominance demodulated on the R-Y axis (V-Axis in the PAL systems).

Facilities for a parade display of camera RGB signals are included in the 1750-Series instruments. The enable and the 3-step staircase signal are input through the rear-panel REMOTE input. Repositioning an internal jumper changes the display to a YRGB parade.

Any of the front-panel switches (except power) may be remotely controlled through rear-panel remote connectors. The control interface is compatible with ground closure or TTL circuits.

The 1750-Series has two input channels, individually selectable from either front-panel push-button switches or by remote ground closure. In addition, it has a dual internal graticule, which reduces parallax and simplifies measurement tasks.

The following paragraphs provide more information on the display modes, and special display features.

### DISPLAY MODES

#### Waveform Mode

In the Waveform Mode, the monitors perform as specialized oscilloscopes to display signal amplitude on the vertical axis and time along the horizontal axis. The vertical gain and horizontal sweep speeds are optimized for viewing standard 1-V amplitude television line and field waveforms. A built-in calibrator provides accurate 1-V amplitude and 10  $\mu\text{s}/\text{cycle}$  (100 kHz) sweep references.

Front-panel push-button switches select sweep speeds for 1 or 2 line (H) and 1 or 2 field (FLD) displays. Magnified line sweep speeds are calibrated for 1  $\mu\text{s}/\text{division}$  and 0.2  $\mu\text{s}/\text{division}$  to allow accurate horizontal blanking and other measurements. In addition, a special combination of sweep rates and magnifier provides a 0.5  $\mu\text{s}/\text{division}$  sweep.

In the Waveform Mode, the vertical amplifier is calibrated to display a 1-V composite video signal terminated in 75  $\Omega$ . Signal lines can be looped through the 1750-Series or terminated at one side of the loop-through connectors, as the

## Introduction and Specification—1750-Series

configuration dictates. A VARIABLE GAIN control and vertical magnifier provide the flexibility to adjust the display amplitude of signals from 200 mV to 2.0 V to full scale. The X5 GAIN switch allows distortion-free vertical magnification.

There are three vertical frequency response filters, FLAT, IRE (1750) or LUM (1751) low-pass to view the luminance portion of signals; and CHROMA bandpass to view frequencies around the subcarrier frequency.

A DC Restorer clamps the back porch to an essentially constant level regardless of changes in signal amplitude or average picture level. (Sync tip clamping is internally selectable.)

### R-Y or V-Axis Mode

In the R-Y Mode (V-Axis) the horizontal axis is swept by the same timebase used in the Waveform Mode. The vertical axis displays the demodulated R-Y (V). The differential phase markings on the right side of the vector graticule are calibrated for use in this mode. The PHASE, VARIABLE, X5 GAIN, and FIELD and LINE SELECTOR are all active in this mode.

### Vector Mode

In the Vector Mode, the monitors provide display of composite video chrominance phase and amplitude. The Vector Mode provides an xy display of the demodulated chrominance. The vertical axis contains the R-Y (1750) or V (1751) components, and the horizontal axis contains the B-Y (1750) or U (1751) components. The resulting display plots chrominance phase as angular information referenced to the color burst, and chrominance amplitude as the radial distance from the center of the display. The PHASE control adjusts the chrominance phase through a continuous 360° range. The VARIABLE, X5 GAIN, and FIELD, and LINE SELECTOR are all operational in this mode.

### SCH Mode

The 1750-Series SCH Mode provides a subcarrier-to-horizontal (SCH) phase measurement display. This display can also be used to convey color frame information when used with an external reference. The SCH Mode provides a vector display of sync phase versus burst phase. The error between the sync and the B-Y (-U) axis, when burst is properly registered, is the SCH phase relationship. SCH phase is measured against the vector graticule, and is displayed so that it can be observed while adjusting a signal source.

The display is time-shared so that the burst vector and sync phase dot, are both displayed. Active video chrominance phase vectors, such as program video or color bars,

are not displayed in this mode to reduce clutter in the display.

The burst vector and a displayed center dot are identically generated in both the Vector and SCH Modes. The sync phase dot is generated by demodulating horizontal sync from a burst-locked oscillator. Figure 1-1 shows a typical SCH Mode display.

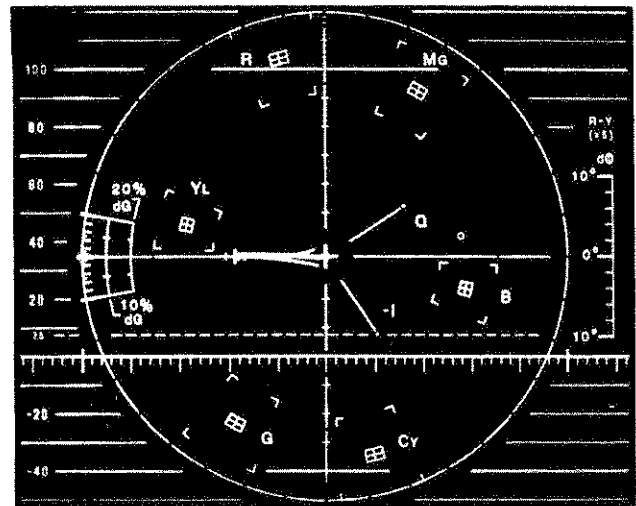

A. 1750

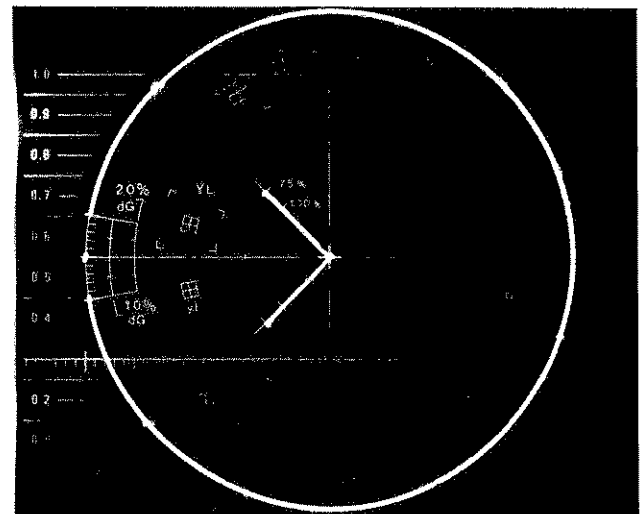

B. 1751

4472-46

Fig. 1-1. Typical SCH Phase measurement displays: A. 1750. B. 1751.

### Combination Modes

The 1750-Series has several additional display modes that can be selected by pushing (simultaneously) two mode buttons.

WFM + R-Y (V-Axis). Provides automatic frequency control (AFC) triggering.

SCH + VECTOR. Selects full field Vector display with the sync dot. This provides a method of viewing all of the chrominance, rather than just the burst.

SCH + WFM. Provides a waveform display with the sweep starting in the center of the line.

SCH + R-Y (V-Axis). Displays horizontal sync phase versus Sweep time.

Other Combinations. Other switch combinations will default to one of the defined operating modes.

### RGB/YRGB Display

Facilities for a parade display of camera RGB signals are included in all 1750-Series instruments. The monitor's REMOTE connector accepts the required enable and 3-step staircase signals from the camera. An internal jumper change permits display of a YRGB parade signal.

### Bright CRT Display

The bright 8 X 10 cm 1750-Series crt display allows use in high ambient light conditions, such as those encountered in field production applications. Brightness remains high in the 1 and 0.2  $\mu$ s magnified sweep speeds, thus enhancing the use of the 1750-Series in evaluating vertical interval test signals and other one- or two-line applications. A parallax-free dual internal graticule, including both the waveform and vector graticules, is standard on both the 1750 and 1751.

### Remote Control Capability

Two rear-panel REMOTE connectors provide remote control of input channel selection, display mode, sweep speeds, frequency response filters, field selection, and the 16 lines on which the front-panel LINE SELECTOR is active.

### Accessories

The standard accessories for the 1750-Series include the instruction manual, power cable, fuses (for power conversion), clear filter, and REMOTE plugs (with housing and strain relief). A full list, including part numbers, is included at the end of the Replaceable Mechanical Parts List, Section 9.

Optional accessories include a carrying case, a cabinet, and a C5C Option 02 camera, rack adapter blank panel, rackmount conversion kit, flipstand for Portable cabinet, 2 circuit board extenders, extender cable (bnc-to-Peltola), and deflection lead extenders.

### Safety Standards

This product is designed and tested in accordance with the requirements for industry safety standards, which include the following:

- UL 1244 Electrical and Electronic Measuring and Testing equipment. Second edition.
- IEC 348 Safety requirements for electronic measuring apparatus. Second edition.
- CSA 556B Electronic Instruments and Scientific apparatus for special use and applications.
- FT2/EMI VDE 0871/6.78 for Category B.
- FCC/EMI FCC Docket 20780, Part 15, Subpart J for Class B Computing Devices.

## SPECIFICATION

The Performance Requirements listed in the Electrical Characteristics apply over an ambient temperature range of 0°C to +50°C. The rated accuracies are valid when the instrument is calibrated at an ambient temperature range of +20°C to +30°C, after a warm-up time of 20 minutes.

Test equipment used to verify Performance Requirements must be calibrated and working within the limits specified in the Recommended Equipment List located in Checks and Adjustments, Section 5.

Table 1-1  
ELECTRICAL CHARACTERISTICS

Vertical Deflection System - Waveform Mode

Characteristic	Performance Requirements	Supplemental Information	Perf Ck Step No.
Frequency Response 1 V Full Scale or in X5 Gain  FLAT	50 kHz to 6 MHz within 2% of response at 50 kHz.	Specifications apply for full screen height video input signal, with variable GAIN control in its detent position, inputs ac or dc coupled.	11
	6 MHz to 8 MHz, within +2%, -5% of response at 50 kHz.		
IRE (1750)	Response per IEEE Std 205 (Fig. 1-1). Response at 15 kHz does not vary between FLAT and IRE by more than 1%.		13 7
LUM (1751)	Less than 3 dB attenuation at 1 MHz and greater than 40 dB attenuation at 4.43 MHz. Response at 15 kHz does not vary between FLAT and LUM by more than 1%.		13 7
CHROMA (1751 values in brackets)	Lower -3 dB point at 2.88 MHz $\pm$ 0.1 MHz. (3.73 MHz $\pm$ 0.1 MHz.)		14
	Upper -3 dB point at 4.28 MHz $\pm$ 0.1 MHz. (5.13 MHz $\pm$ 0.1 MHz.)		14
	Response at 3.58 (4.43) MHz does not vary between FLAT and CHROMA by more than 1%.		14
	Attenuation at 7.2 MHz (8.9 MHz) greater than 25 dB.		14

Table 1-1 (cont)

## Vertical Deflection System - Waveform Mode (cont)

Characteristic	Performance Requirements	Supplemental Information	Perf Ck Step No.
Transient Response 1 V Full Scale or in X5 Gain FLAT (using 2T pulse and 2T bar)		Specifications apply for full screen height video input signal, with variable GAIN control in its detent position.	
Preshoot	1% or less.		
Pulse-to-Bar Ratio	0.99:1 to 1.01:1.		12
Overshoot	2% or less.		12
Ringing	2% or less.		12
Tilt Field Rate Square Wave or Vertical Window	1% or less.		12
25 $\mu$ s Bar	1% or less.		12
Overscan	Less than 2% variation in baseline of 100 IRE (700 mV) 12.5T (20T) modulated pulse as it is positioned over the middle 80% of the screen, with the inputs ac coupled.	Variable GAIN control in detent. X5 GAIN selected.	12
Differential Gain	1% or less with 10% and 90% APL changes.	Chroma filter must be selected. Baseline at 50 IRE and displayed sub- carrier adjusted to 100 IRE with X5 and VAR gain.	19
Deflection Factor 1 V Full Scale	140 IRE (1.0 V) within 1% with 1 V input.	With FLAT response selected.	7
With X5 Gain	140 IRE (1.0 V) within 3% with 0.2 V input.		
Variable Gain Range 1 V Full Scale	Input signals between 0.7 V and 2 V can be adjusted to 140 IRE (1.0 V) display.		7
With X5 Gain	Input signals between 0.7 V and 2 V can be adjusted to a 140 IRE (1.0 V) display.		7
Maximum Absolute Input Level	$\pm 2$ Vdc + peak ac.	Displays in excess of 200 IRE (1.428 V) may cause frequency response aberrations.	
DC Input Impedance (Unterminated)	Greater than 15 $\Omega$ .		22

Table 1-1 (cont)

## Vertical Deflection System - Waveform Mode (cont)

Characteristic	Performance Requirements	Supplemental Information	Perf Ck Step No.
DC Input Impedance (cont) Return Loss (75 $\Omega$ ) Video Inputs (CH-A, CH-B)	At least 40 dB from 50 kHz to 6 MHz.	A and B channels, loop-through terminated in 75 $\Omega$ . Input in use or not in use, instrument power on or off, all deflection factor settings.	22
Crosstalk between Channels		Greater than 70 dB isolation between channels. Measured at Fsc between CH-A, CH-B, and EXT REF.	
Loop Through Isolation		Greater than 80 dB isolation between channels. Measured at Fsc between CH-A, CH-B, and EXT REF.	
PIX MON OUT Frequency Response	50 kHz to 6 MHz, within 3% of response at 50 kHz.	Terminated in 75 $\Omega$ .	
Differential Gain (50% APL)	Within 1% with a 140 IRE (1.0 V) unit display.		
Differential Phase (50% APL)	Within 1° with a 140 IRE (1.0 V) unit display.		
Dc Level on Output	0.5 V or less into 75 $\Omega$ load.	Input ac or dc coupled with no input signal applied.	9
Output Impedance (Nominal)		75 $\Omega$	
Return Loss (75 $\Omega$ )	At least 30 dB, 50 kHz to 6 MHz.	With instrument turned on.	22
Input to PIX MON OUT Gain Ratio	1:1 $\pm$ 5% at 15 kHz.	PIX MON OUT not affected by front-panel controls other than the INPUT and LINE SELECTOR settings.	9



Table 1-1 (cont)

## DC Restoration

Characteristic	Performance Requirements	Supplemental Information	Perf Ck Step No.
DC Restorer Clamp Time		Back Porch or Sync Tip. Selectable with an internal jumper. Factory set to Back Porch.	
Low-Frequency Response at 60 Hz Attenuation of 60 Hz on Input Signal	20% or less.		10
Blanking Level Shift with 10% to 90% APL Change	APL changes from 50% to either 10% or 90% will cause blanking level shift of 1 IRE unit (7 mV) or less.	Input ac or dc coupled.	10
Blanking Level Shift Due to Presence or Absence of Burst	1 IRE unit (7 mV) or less shift from no color burst to presence of color burst.		10

## Calibrator

Characteristic	Performance Requirements	Supplemental Information	Perf Ck Step No.
Calibrator Signal Frequency	100 kHz, $\pm 0.1$ kHz.  Synchronizes in 2H and 1H sweep.	Crystal controlled. Timing accuracy is 10 $\mu$ s, $\pm 10$ ns. Can be used as 10 $\mu$ s timing calibrator in magnified 2H SWEEP.	8
Amplitude	1 V, $\pm 0.5\%$		8
Position		Top of calibrator waveform must be between 80 IRE (0.86 V) and 120 IRE (1.14 V) on graticule when Back Porch of video signal is positioned to 0 IRE (0.300 V) line, with back porch DC RESTORER on.	

Table 1-1 (cont)

## Horizontal Deflection System

Characteristic	Performance Requirements	Supplemental Information	Perf Ck Step No.
Sweep	Sweep will occur in all Horizontal mode settings with or without synchronization.		4
1FLD Sweep Repetition Rate Even or Odd	Equal to frame rate of applied video or external sync.	Displays one field.	4
Both	Equal to field rate of applied video or external sync.	Displays one field.	4
2FLD Sweep Repetition Rate Even or Odd	Equal to frame rate of applied video or external sync.	Displays two fields. (one frame)	4
Both	Equal to field rate of applied video or external sync.	Displays one field.	4
1FLD MAG and 2FLD MAG Sweep Magnification		Approximately X20	
2FLD MAG Registration	Some portion of vertical blanking interval is visible when unmagnified 2FLD sweep is centered.		4
1H Sweep Repetition Rate	Equal to line rate of applied video or external sync.	Displays one field.	4
2H Sweep Repetition Rate	Equal to half line-rate of applied video or external sync.	Displays two lines.	4
Sweep Length		2H and 2FLD sweep length is nominally 12.5 divisions.	4
Timing Accuracy 1 $\mu$ s/div.	To within 2%	All timing and linearity specifications exclude the first and last major divisions of the unmagnified display.  Timing can be adjusted $\pm 5\%$ with front-panel SWEEP CAL.	5
0.2 $\mu$ s/div	To within 2%		5
Linearity 1 $\mu$ s/div and 0.2 $\mu$ s/div	Within 2%		5
2H MAG Registration	Some portion of the horizontal blanking interval is visible when unmagnified 2H is centered.		4
HORIZONTAL Position	Any portion of a synchronized video sweep can be positioned to any point on the screen in all sweep modes.		4

Table 1-1 (cont)

## Synchronization

Characteristic	Performance Requirements	Supplemental Information	Perf Ck Step No.
Input Requirements SCH Modes	Composite video or black burst, 286 mV (NTSC) 300 mV (PAL) sync and burst, $\pm 3$ dB.		3
Other Modes	Stable display with Composite video, black burst, or composite sync with 286 mV (NTSC) or 300 mV (PAL), $\pm 6$ dB.		3
EXT REF (Waveform Mode)	Sync amplitude between 143 mV and 4 V.		3
EXT REF Input Dc Input Impedance (Unterminated)	Greater than 15 k $\Omega$ .		
Return Loss (75 $\Omega$ )	At least 40 dB from 50 kHz to 6 MHz.		22
Absolute Maximum Input Voltage		$\pm 12$ Vdc plus peak ac.	
Maximum Operating Input Voltage		Peak ac + dc should be within +8.0 V and -5.6 V for proper operation.	

## RGB/YRGB Mode

Characteristic	Performance Requirements	Supplemental Information	Perf Ck Step No.
RGB/YRGB	Will display either a 3 or 4 step RGB/YRGB display.	The Waveform Mode must be selected.	6
Staircase Amplitude RGB or YRGB	A 10 V input will result in a horizontal display of 9 divisions $\pm 1.4$ major divisions.		6
Maximum Operating Staircase Signal Voltage	12 V p-p ac component. Signal voltage not to exceed $\pm 12$ Vdc plus peak ac.		
Sweep Repetition Rate	Field or line rate of displayed video or external sync signal as selected by front-panel HORIZONTAL controls.	2H and 2FLD SWEEP rates overridden in the RGB/YRGB mode.	6
Control		RGB/YRGB mode selected by applying ground (TTL low) at the appropriate pin on the rear-panel REMOTE connector.	
MAGnifier		Functions in normal manner for RGB/YRGB.	6
Sweep Length	3 step: 3.4 - 4.1 divs. 4 step: 2.5 - 3.1 divs.	Field or line rate sweeps.	6

Table 1-1 (cont)

## Vector Mode

Characteristic	Performance Requirements	Supplemental Information	Perf Ck Step No.
Chrominance Processing Characteristics			
Nominal Subcarrier Frequency			
NTSC (1750)		3.579545 MHz.	
PAL (1751)		4.43361875 MHz.	
Chrominance Bandwidth			
Upper -3 dB Point	Fsc +500 kHz, $\pm$ 100 kHz.		15
Lower -3 dB Point	Fsc -500 kHz, $\pm$ 100 kHz.		15
+V/PAL (1751)		PAL or +V-type display as selected by front-panel button. When pushed, V axis is inverted at a 1/2 line rate to produce a single vector display.	
Display			
Vector Phase Accuracy	$\pm$ 1.25°.	Measured with Color Bar signal.	16
Vector Gain Accuracy	$\pm$ 2.5%.		16
Quadrature Phasing	Within 0.5°.		
Subcarrier Regenerator		Subcarrier Regenerator free runs in absence of appropriate signal.	
Pull-In Range			
1750	$\pm$ 50 Hz of Fsc.		17
1751	$\pm$ 10 Hz		
Pull-In Time		Within 1 second, with subcarrier frequency within 50 Hz (10 Hz for 1751) of Fsc.	17
Phase Shift with Subcarrier FREQUENCY CHANGE			
1750	$\pm$ 0.5° from Fsc to (Fsc +50 Hz), or Fsc to (Fsc -50 Hz).		17
1751	$\pm$ 0.5° from Fsc to (Fsc +10 Hz), or Fsc to (Fsc -10 Hz).		17

Table 1-1 (cont)

## Vector Mode (cont)

Characteristic	Performance Requirements	Supplemental Information	Perf Ck Step No.
Phase Shift with Burst Amplitude Change	$\pm 2^\circ$ from nominal burst amplitude to $\pm 6$ dB.	Internal or External burst reference.	17
Phase Shift with Input Channel Change	$\pm 0.5^\circ$ .	With EXT REF selected.	18
Phase Shift with Reference Switched Between Internal and EXT REF	$\pm 0.5^\circ$ .		18
Phase Shift with X5 Gain	$\pm 2.0^\circ$ .		18
Phase Shift with VAR GAIN Control	$\pm 1^\circ$ as gain is varied from 3 dB to $-6$ dB.		18
PHASE Control Range		360° continuous rotation.	
Burst Jitter	0.5° or less.	With 140 IRE (1 V) composite video input. INT or EXT referenced.	18
Display Characteristics			
Differential Phase	$\pm 1^\circ$ .		19
Differential Gain	$\pm 1\%$ .		
Position Control Range			
VECTOR HORIZ	At least 6 mm from center.		20
VECTOR VERT	At least 6 mm from center.		
Clamp Stability	0.04 mm (1/64") or less.	Center Spot Movement with Rotation of PHASE Control.	20
Variable GAIN Range	Input subcarrier signals between 210 mV and 1.05 V can be adjusted to normal burst vector length.		
With X5 GAIN Selected	Input subcarrier signals between 43.2 mV and 210 mV can be adjusted to normal burst vector length.		21

Table 1-1 (cont)

## SCH Mode

Characteristic	Performance Requirements	Supplemental Information	Perf Ck Step No.
Accuracy			
Absolute	$\pm 5^\circ$ phase at $25^\circ\text{C}$ .		23
Relative		$\pm 2^\circ$	
Temperature Coefficient		$\pm 0.1^\circ$ phase/ $^\circ\text{C}$ .	
Acquisition Time	Less than or equal to 1 sec.		23
Display Phase Error		$\pm 1.25^\circ$ , calibrated for zero display phase error at zero SCH phase.	
Ext Reference to Int Reference Match	$\pm 0.5^\circ$		25
CH A to CH B Match	$\pm 0.5^\circ$		25
Input Timing		Stable display with any time relationship between signals on CH A, CH B, and EXT REF.	
Display Range			
EXT REF	$360^\circ$ .		
Int. Ref.	$\pm 80^\circ$ .		24

## Crt Display

Characteristic	Performance Requirements	Supplemental Information	Perf Ck Step No.
Crt Viewing Area		80 X 100 mm. (Horizontal, 12.5 divisions; Vertical, 170 IRE units (1.19 V).	
Accelerating Potential		15 - 16.25 kV. (17.5 kV max.)	
Trace Rotation Range	Greater than $\pm 1^\circ$ from horizontal.	Total adjustment range is typically $8^\circ$ .	
Graticule			
1750	Internal with variable SCALE illumination.		
1751	Internal with variable SCALE illumination.		

Table 1-1 (cont)

## Power Source

Characteristic	Performance Requirements	Supplemental Information	Perf Ck Step No.
Mains Voltage Ranges 115 V 230 V	90-132 V 200-250 V		2
Mains Frequency Range	48 Hz to 66 Hz.		
Power Consumption		48 Watts (163 BTU/hr) maximum.	

Table 1-2  
ENVIRONMENTAL CHARACTERISTICS

Characteristics	Supplemental Information
Temperature Non-Operating	-55°C to +75°C.
Operating	0°C to +50°C.
Altitude Non-Operating	To 15,000 meters (50,000 feet).
Operating	To 4,500 meters (15,000 feet).
Vibration Operating	15 minutes each axis at 0.015 inch, frequency varied from 10-55-10 Hz in 1-minute cycles with instrument secured to vibration platform. Ten minutes each axis at any resonant point or at 55 Hz if no resonant point is found.
Shock Non-Operating	30 g's, 1/2 sine, 11 ms duration, 3 shocks per surface (18 total).
Transportation	Qualified under NTSC Test Procedure 1A, Category II (30-inch drop).
Humidity	Will operate at 95% relative humidity for up to five days. Do not operate with visible moisture on circuit boards.

Table 1-3  
CERTIFICATION

Characteristics	Information
Safety	Designed to meet or exceed: UL 1244 Factory Mutual 3820 CSA Bulletin 556B IEC 348 (VDE 0871.5 Class B)
Electro-Magnetic Interference	Conforms with FCC EMI Compatibility (FCC Rules Part 15 Subpart J, Class A)

Table 1-4  
PHYSICAL CHARACTERISTICS

Characteristics	Information
Dimensions	
Height	133.4 mm (5 1/4 inches).
Width	215.9 mm (8 1/2 inches).
Length	460.4 mm (18 1/8 inches).
Weight	Approximately 8 kg (18 lbs).

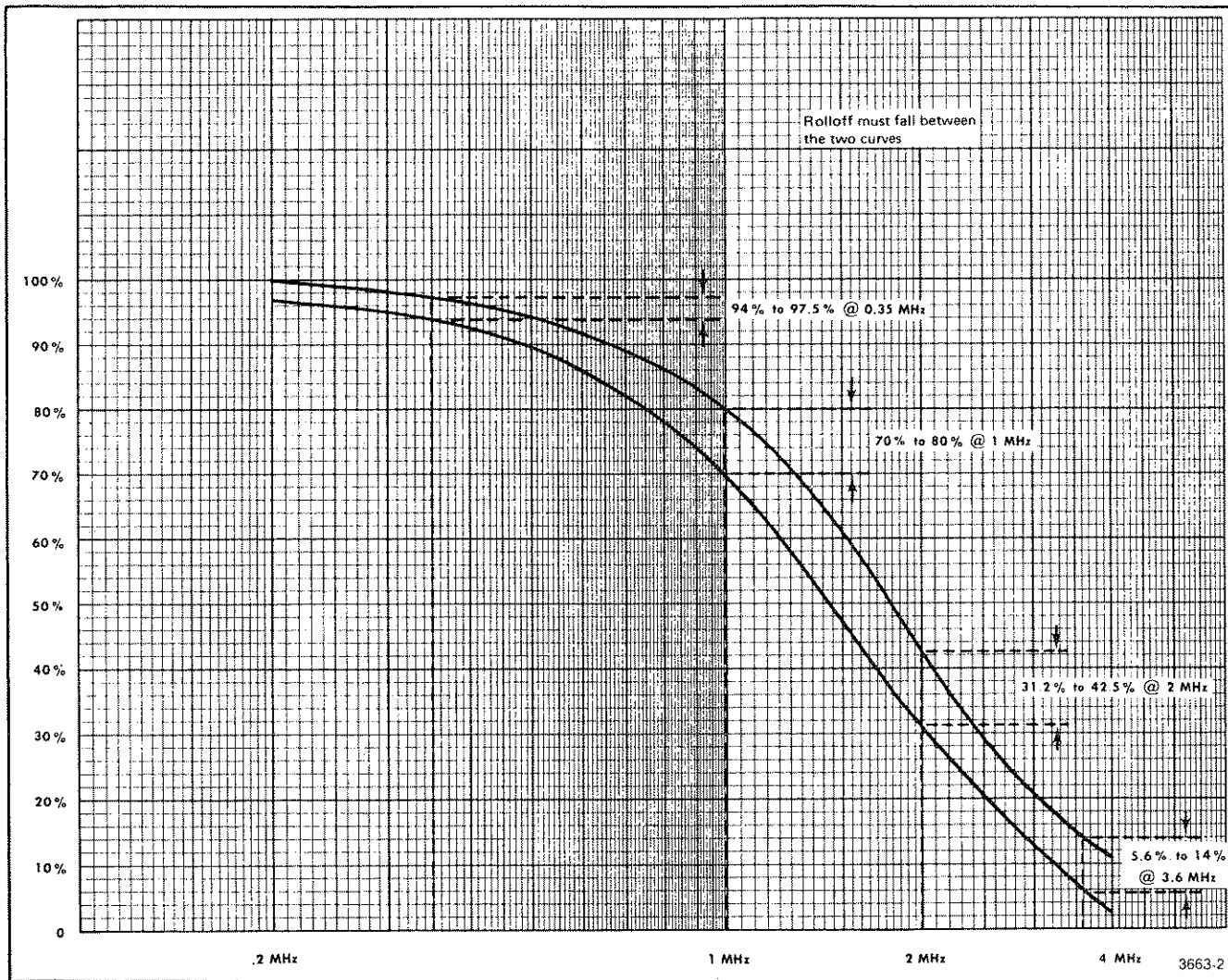

Fig. 1-2. IEEE 1972 Standard 205. (Formerly IRE 1958 Standard 23S-1.)



# OPERATING INSTRUCTIONS

## Introduction

This section of the manual contains a description of the controls, connectors, and indicators, an Operator's Check-out Procedure, and general familiarization information, which includes the operating instructions.

## CONTROLS, INDICATORS, AND CONNECTORS

Brief descriptions of the function and operation of the front- and rear-panel controls, indicators, and connectors are provided here. Refer to Figs. 2-1 and 2-2 for locations.

### Front-Panel Controls and Indicators

The numbers accompanying the descriptions of front-panel controls and indicators refer to locations on Fig. 2-1.

- ① POWER. Push-button switch that turns the instrument power on or off. Either the LOCAL or REMOTE indicator will light to indicate the presence of power.
- ② SCALE. Controls the illumination of the graticule.
- ③ INTENSITY. Controls brightness of the display.
- ④ FOCUS. Adjusts the display for optimum definition.
- ⑤ VERT POS. Multi-turn control that vertically positions the waveform display.
- ⑥ HORIZ POS. Multi-turn control that horizontally positions the waveform display.
- ⑦ WAVEFORM VERT CAL. Screwdriver adjustment for calibration of the vertical axis in the Waveform (WFM) Mode.
- ⑧ SWEEP CAL. Screwdriver adjustment for calibration of the horizontal axis in the Waveform Mode.
- ⑨ INPUT A and B. A pair of self-cancelling push-button switches to select the video input.
- ⑩ CAL (Waveform Mode Only). Push button to select the calibrator square wave for display. The signal provides a 1 V amplitude reference and a 10  $\mu$ s/cycle (100 kHz) timing reference. This switch overrides the input A or B selection in Waveform Mode, but has no effect in other modes.
- ⑪ EXT REF. Push button to select either internal or external sync and phase reference. Composite video, including black burst can be used for the reference. Composite sync can be used as the reference for Waveform Mode, but the other modes require a burst of subcarrier for a phase reference.
- ⑫ GAIN. A control, with an indicator and a fixed magnifier switch, that affects the gain of all modes, except the horizontal component of the Waveform Mode.
 

VARIABLE (Waveform). Variable control to allow any waveform signal between 0.7 V and 2 V peak-to-peak to be made full scale. Detent is fully clockwise. Just out of detent is maximum gain; going counterclockwise turns gain down.

(Vector Mode, R—Y) Allows chrominance signals between 210 mV and 1.05 V to be made normal burst vectorlength.

UNCAL Indicator. The UNCAL indicator lights when the Variable GAIN control is moved out of the detent calibrated position.

X5. Pressing in the X5 button provides waveform magnification of a 0.2 Volt signal to a full scale calibrated display (when the Variable GAIN control is in the calibrated detent position). In Vector Mode, it provides five times nominal gain.
- ⑬ REMOTE-LOCAL. Indicator LEDs that light to show whether local or remote operation is being used. When remote operation is in use, all front-panel push buttons are disabled.

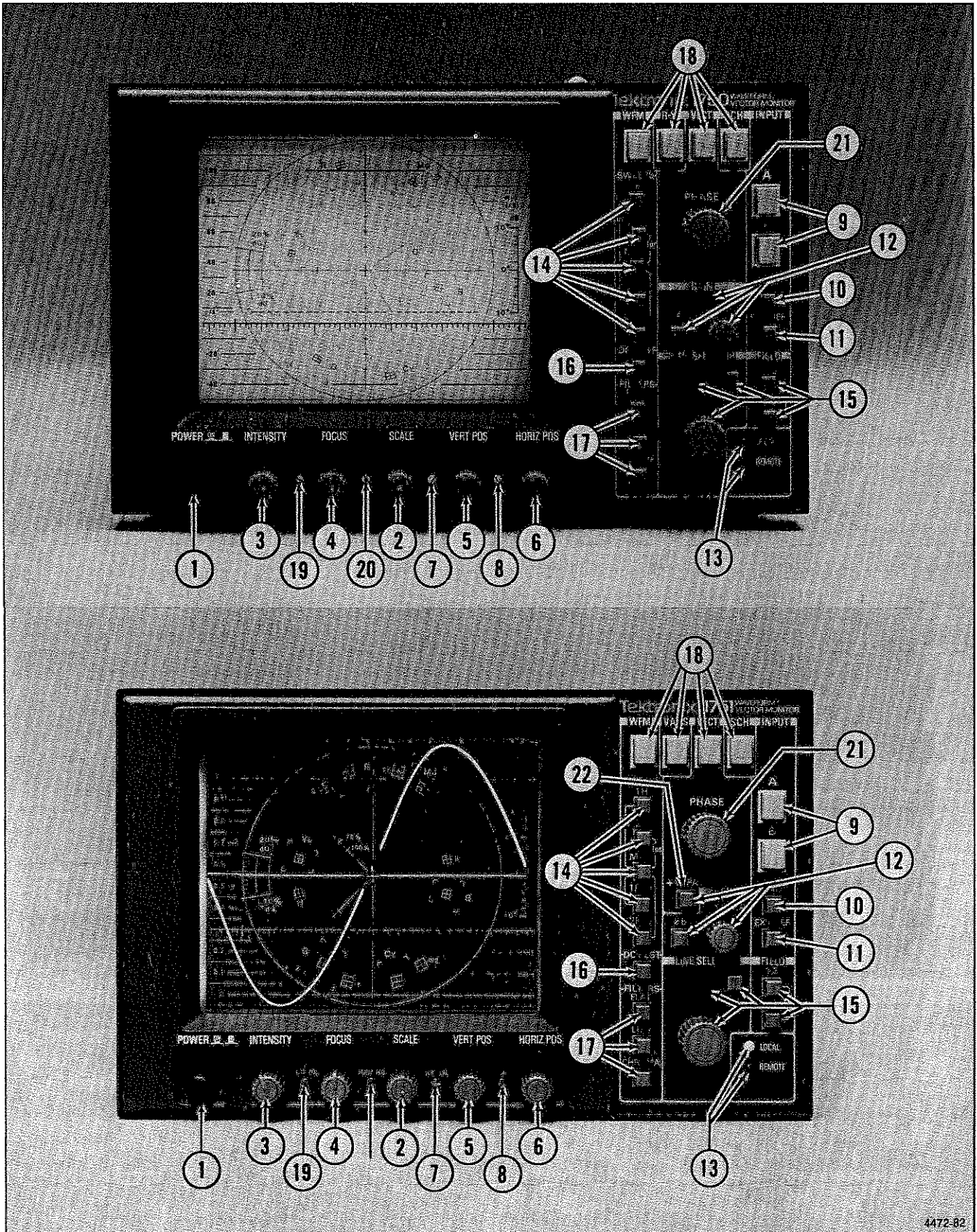

Fig. 2-1. Front-panel controls and indicators.

- ⑭ **SWEEPS.** A set of switches that select sweep speeds or modes.

1H, 2H, 1FLD, and 2FLD. Four self-cancelling push-button switches that select the horizontal sweep rates:

1H. Sweep is at the line rate. One horizontal television line is displayed.

2H. Sweep rate is one-half the line rate. Displays two television lines.

1FLD. Sweep is at the field or frame rate. One television field is displayed.

2FLD. Sweep is at the frame rate (one-half the field rate). One television frame (two fields) is displayed in either even or odd field selection. Fields are overlaid for display if both field selection buttons are pushed.

MAG. Push button used with the sweep selection switches to provide magnification of each rate as follows:

1H MAG. =  $0.2 \mu\text{s}/\text{div}$  (calibrated).

2H MAG. =  $1 \mu\text{s}/\text{div}$  (calibrated).

1FLD or 2FLD MAG. = approximately X20 magnification.

- ⑮ **LINE SELECT ON.** Push-button switch that enables the LINE SELECT feature.

LINE SELECT. Rotary switch selects lines for display.

SELECTED LINE. A readout of the line number for the line (or the first line of the two lines) being displayed.

FIELDS 1 & 3 or FIELDS 2 & 4. Push-button switches select even or odd field triggering. When both switches are pressed, all fields are overlaid.

- ⑯ **DC REST.** Push button that enables the DC RESTorer clamp. Clamp time is factory set to the back porch of the composite video signal, but can be internally set to clamp during the sync tip.

- ⑰ **FILTERS.** Three self-cancelling, push-button switches that select the response characteristics of the vertical channel.

FLAT. Provides flat (normal) response.

IRE (1750). Provides low-pass response according to the IRE response curve.

LUM (1751). Provides a low-pass response to display the luminance portion of the composite video signal.

CHROMA. Provides bandpass response centered on the chrominance subcarrier frequency. Displays frequencies around the subcarrier frequency.

- ⑱ **Mode Selection.** Four self-cancelling, push-button switches used to select the monitor display mode as follows:

WFM. Selects the Waveform Mode. Provides an amplitude versus time display to operate as a waveform monitor.

R-Y (1750) or V-Axis (1751). Selects demodulated chrominance versus time display. The chrominance is demodulated on the R-Y (V) axis when burst is lined up on the normal axis. The PHASE control can adjust the demodulator phase to any axis.

VECT. Selects the Vector Mode, which presents an XY plot of demodulated chrominance phase and amplitude. The angle represents chrominance phase and the distance from the center represents chrominance amplitude.

SCH. Selects a vector display of the subcarrier to horizontal sync (SCH) phase relationship. The burst vector and the phase of the 50% point of the leading edge of sync are displayed.

SCH + VECT. Pressing both the SCH and the VECT buttons selects a full field Vector display with the sync dot. This allows viewing all of the chrominance, rather than just the burst. (Some vertical interval lines may be blanked in this mode. To check SCH versus a signal in the vertical interval, switch between VECT and SCH.)

SCH + WFM. This combination of switch settings provides a display similar to the Waveform Mode, except the sweep starts at the center of the line. This allows viewing the sync edge at the maximum sweep rate, 1H MAG.

SCH + R-Y (V-Axis). This combination of switch settings displays horizontal sync phase versus Sweep time. With 2FLD sweep selected, this display can be used to set SCH

## Operating Instructions—1750-Series

phase by nulling the signal. This mode provides a display that is easily visible from a distance, and independent of the graticule markings. The display is also useful to view timebase error in video tape recorders and other video sources. Because of the 25-Hz offset in the PAL system, the display is an opposed sine wave when +V is selected.

WFM + R-Y (V-Axis). These switch settings enable the waveform display with automatic frequency control (AFC) triggering to stabilize the triggering, so that sync jitter can be viewed.

Other Combinations. Other switch combinations will default to one of the previously defined operating modes.

### NOTE

To avoid confusion, only use the settings or combinations listed above.

- ①9 VECTOR VERT POS. A screwdriver adjustment that provides vertical positioning of the Vector, R-Y, or SCH display.

- ②0 VECTOR HORIZ POS. Screwdriver adjustment provides limited horizontal positioning of the Vector and SCH displays.

- ②1 PHASE. A continuously variable control with 360° range that is used to set the phase of the demodulator reference.

- ②2 +V/PAL (1751 Only). Push button that selects either PAL (+V and -V on alternate lines) or +V. With the button pressed in, the phase reference of the -V lines is inverted, then overlaid on the +V line to provide a comparison display.

### Rear-Panel Connectors and Switch

Fig. 2-2 shows the rear panel of the 1750/1751. The numbers accompanying the descriptions of rear-panel connectors and the switch are references to Fig. 2-2.

- ① CH-A. 75-Ω loop-through video input connectors.

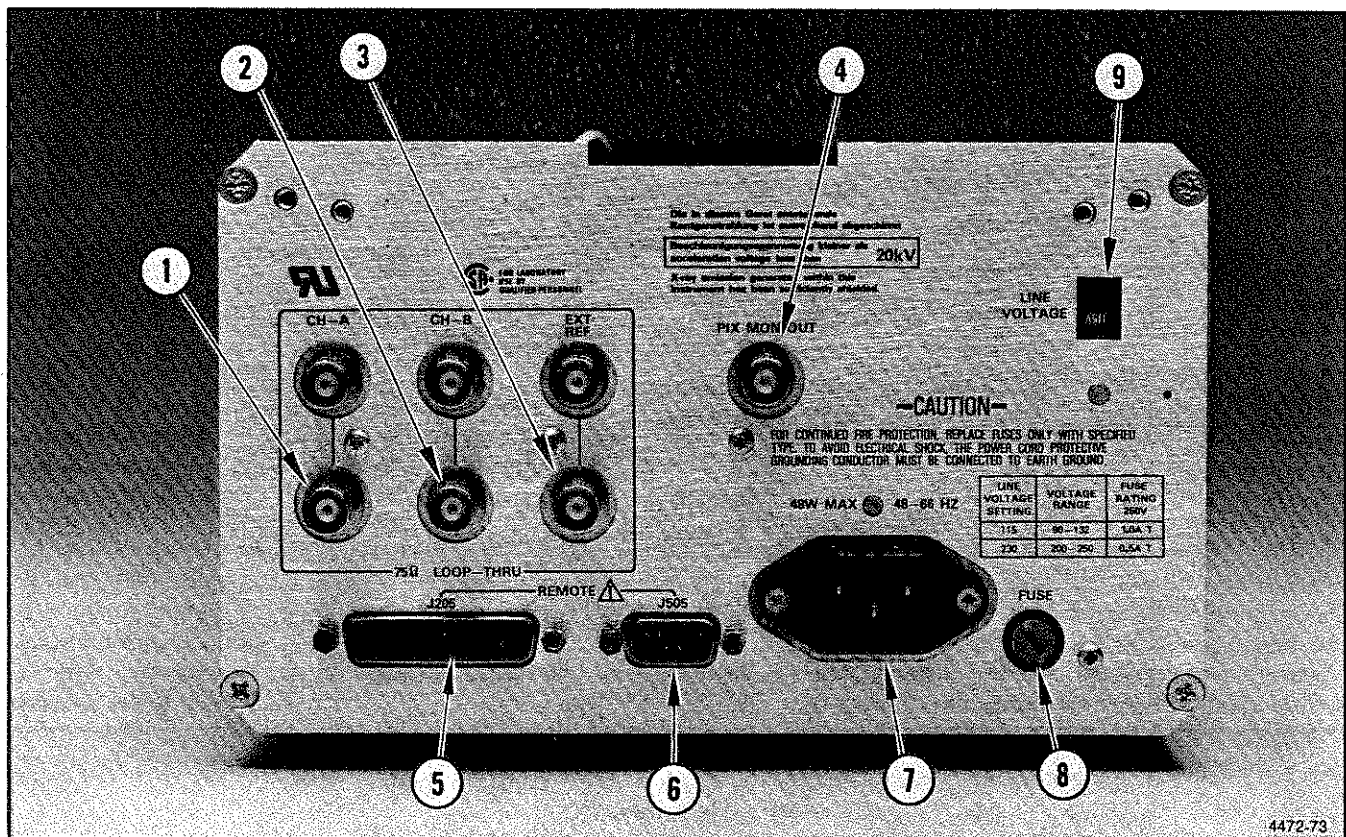

Fig. 2-2. 1750-Series rear panel.

- ② CH-B. 75-Ω loop-through video input connectors.

The 1750-Series uses bridging loop-through inputs, all lines will require terminations.

- ③ EXT REF. 75-Ω loop-through input selected by the front-panel EXT REF switch. The input signal provides the external sync and phase reference. The instrument will operate from external references of composite video, including black burst. Composite sync can act as a reference for the Waveform Mode, but the other modes require a subcarrier burst for phase reference.

- ④ PIX MON OUT. 75-Ω output, with X1 gain, of the selected video input signal. With the LINE SELECTOR on, a line strobe pulse provides a dc offset of the selected line, thus brightening that line when displayed on a picture monitor. The output signal is not affected by front-panel controls other than the INPUT and CAL selector buttons and the FIELD and LINE SELECTOR switches.

- ⑤ REMOTE Connector (J205). A 25-pin connector that provides remote access of various inputs. Inputs include remote control of front-panel switches, RGB/YRGB staircase input from camera control unit for parade display, and a remote sync input.

- ⑥ REMOTE (Line Select Connector) (J505). A 9-pin connector that can be used, in conjunction with the front-panel LINE SELECTOR to display a particular line (or two lines) from either the even or odd field.

- ⑦ Power Plug. Connection for the power mains.

- ⑧ Fuse. AC power input fuse (instrument main fuse).

- ⑨ Power Line Selector. Provides a nominal choice of 115 or 230 Vac operation.

## OPERATOR'S CHECKOUT PROCEDURE

If performing the Operator's Checkout Procedure reveals improper operation or instrument malfunction, first check the operation of associated equipment. Then, refer to qualified service personnel for repair or adjustment of the instrument.

When a complete check of the instrument performance to specification is desired, refer qualified service personnel to the Performance Check in Section 5 of this manual.

This procedure requires a source of composite video and composite sync signals. TEKTRONIX 1410-Series Television Test Signal Generator mainframes with Sync, Color Bar, and Linearity modules were used in preparing this procedure.

## 1. Initial Setup

### Video Signal Generator

Test Signals	Full Field Color Bars 75% Ampl. 7.5% Setup—NTSC 75% Ampl. 0% Setup (75/0)—PAL
	Modulated Staircase (Flat Field, 10 Step)
	Black Burst Signal (Sync and Burst only)

### 1750-Series Monitor

Mode	WFM (Waveform)
INPUT	A
CAL (Calibrator)	Off (out)
EXT REF	Internal Reference (out)
SWEEPS	1H
MAG	Off (out)
DC REST	Off (out)
FILTERS	FLAT
GAIN	
X5	Normal (out)
VARIABLE	CAL (fully cw)
PHASE	As is
+V/PAL (1751)	PAL (out)
LINE SELECTOR (button)	Off (out)
LINE SELECTOR (rotary)	As is
FIELD	As is
INTENSITY	Fully ccw
FOCUS	As is
SCALE	As is
VERT POS	As is
HORIZ POS	As is
VECTOR VERT POS	As is
VECTOR HORIZ POS	As is
WAVEFORM VERT CAL	As is
SWEEP CAL	As is
POWER	Off (out)

## 2. Apply Power

Connect the instrument to a suitable ac power source and set the POWER switch ON.

**NOTE**

*Do not set any of the front-panel screwdriver controls until after the instrument warms up.*

**3. Obtain Display**

Adjust the INTENSITY and FOCUS controls for the desired brightness and a well-defined trace. (If necessary, adjust the multi-turn VERT POS and HORIZ POS controls to bring the trace on screen.)

Adjust the SCALE illumination control for the desired brightness.

**4. Calibrate Display**

The CAL switch enables the Waveform Mode calibrator signal. Press the CAL switch and adjust the VERT and HORIZ POS controls to obtain a display similar to that shown in Fig. 2-3. If necessary, adjust the WAVEFORM VERT CAL and SWEEP CAL screwdriver controls for 1 V amplitude (0.7 V to -0.3 V graticule markings) and two horizontal divisions per cycle of the calibrator waveform. Release the CAL switch.

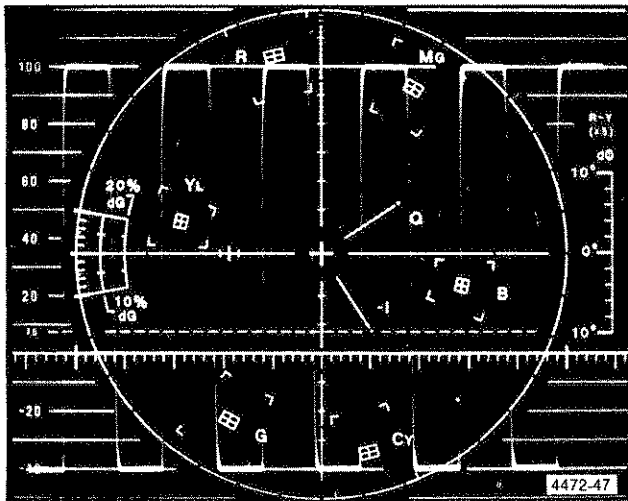

Fig. 2-3. Calibrator waveform displayed in WFM Mode.

**5. Select Input**

The Input switches (INPUT A and B) select the rear-panel CH-A or CH-B inputs. Connect the Color Bar signal to the CH-A INPUT. Terminate the remaining side of the loop-through input with a 75-Ω termination.

Position the waveform so that the blanking level is at the 0 V graticule line and with the sync pulses at each end of the graticule. This is the typical Waveform display setup.

Select the CH-B Input. Note that the display is a straight horizontal trace, indicating no input.

Connect the Modulated 10 Step Staircase to the CH-B Input and again terminate the remaining side of the loop-through input with a 75-Ω termination. Note the presence of the Modulated Staircase display.

Return to the Channel A Color Bar display.

**6. Select Timing Reference**

The EXT REF switch selects internal or external timing references. Set the monitor to EXT REF. The display is unlocked with no signal connected to the EXT REF input.

Connect the Black Burst signal from the Video Signal Generator to the rear-panel EXT REF LOOP-THRU input. Terminate the loop-thru with a 75-Ω end-line termination. See that the display locks to the external reference.

Leave the monitor in EXT REF.

**7. Check GAIN**

The normal GAIN setting (VARIABLE in detent) gives 1 V full scale. The X5 and VARIABLE GAIN control changes the display amplitude.

Turn the VARIABLE GAIN control out of its detent and notice that the red UNCAL indicator lights. Note the range of amplitude obtained with the control.

Adjust the VARIABLE GAIN control to obtain two vertical divisions of displayed sync amplitude.

Press the X5 GAIN switch. Notice that the displayed sync amplitude is magnified to ten divisions.

Release the X5 GAIN switch and turn the VARIABLE GAIN control fully clockwise to its detent position, returning to the normal 1 V full scale gain setting.

**8. DC Restoration**

The DC REST switch provides clamping (dc restoration) of the input signal in the Waveform Mode. Switch the luminance (Y) component of the Color Bar signal off and on at the generator. Notice that the blanking level of the display shifts as the luminance is switched.

Press the DC REST switch. Again switch the generator Color Bar signal luminance (Y) off and then back on. This time, notice that the blanking level remains stable.

Release the DC REST switch.

**NOTE**

*This check is not effective if the internal jumpers select dc coupling.*

**9. Filter Response**

The FILTERS switches select frequency response characteristics for the displayed signal. The FLAT response selection is used for normal applications. Fig. 2-4 shows the Color Bar signal with FLAT response.

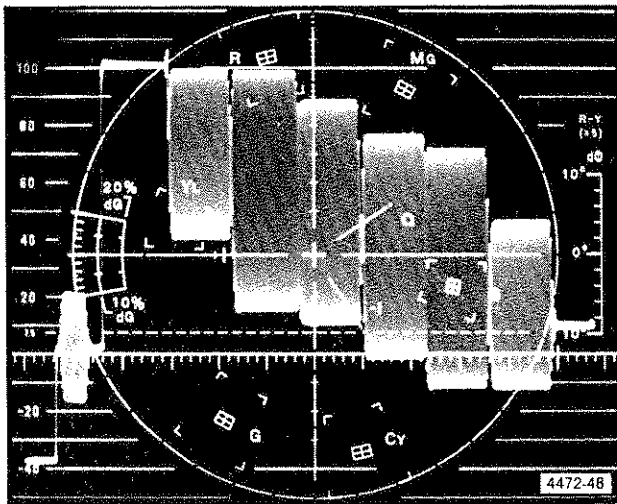

Fig. 2-4. Color Bar signal displayed with FLAT response.

Press the IRE (1750) or LUM (1751) FILTER switch. This cancels the FLAT switch and provides low-pass frequency response. The waveforms in Fig. 2-5 show the low-pass responses of the various monitors to appropriate Color Bar signals.

Press the CHROMA switch. This cancels other FILTERS selections and provides a chrominance bandpass response, thus removing the luminance component of the signal. Fig. 2-6 shows a typical Color Bar signal using the CHROMA FILTER.

**10. Sweep Speeds**

Check that the 1H, 2H, 1FLD, and 2FLD SWEEP selections provide the appropriate line and field video displays as shown in Fig. 2-7.

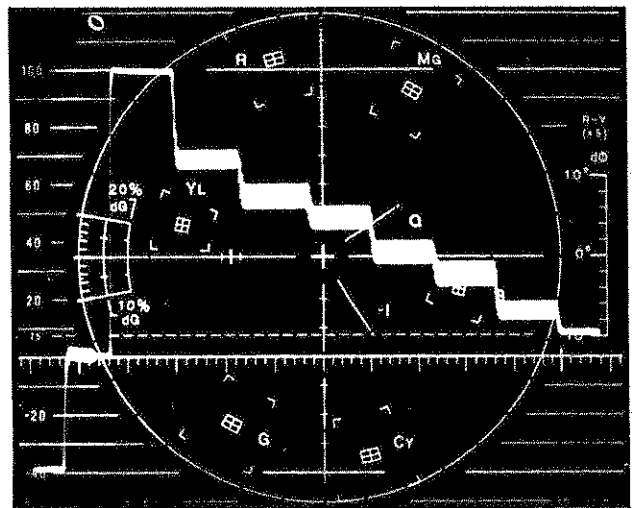

A. 1750 IRE FILTER

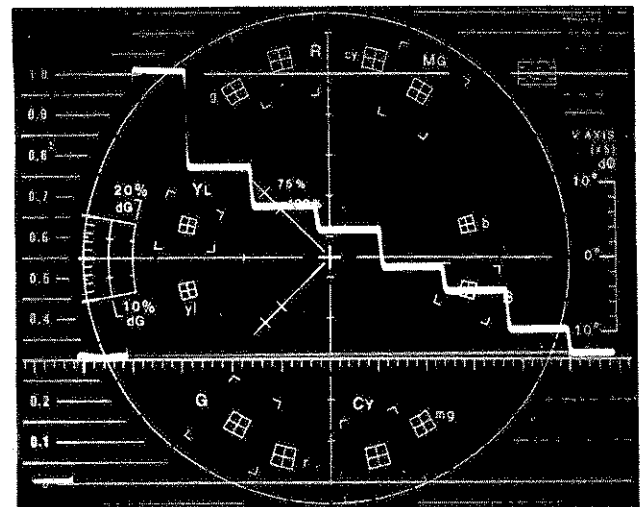

B. 1751 LUM FILTER

4472-49

Fig. 2-5. 1750-Series Low-Pass Luminance Filters: A. 1750 IRE Filter. B. 1751 LUM Filter.

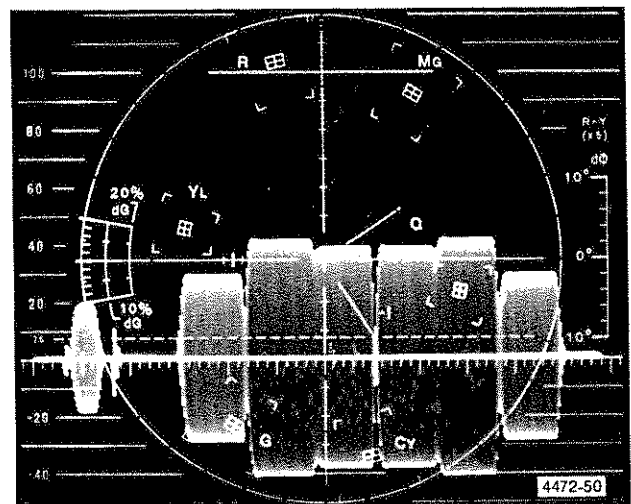

Fig. 2-6. Typical display when the Chrominance (CHROMA) Filter is used.

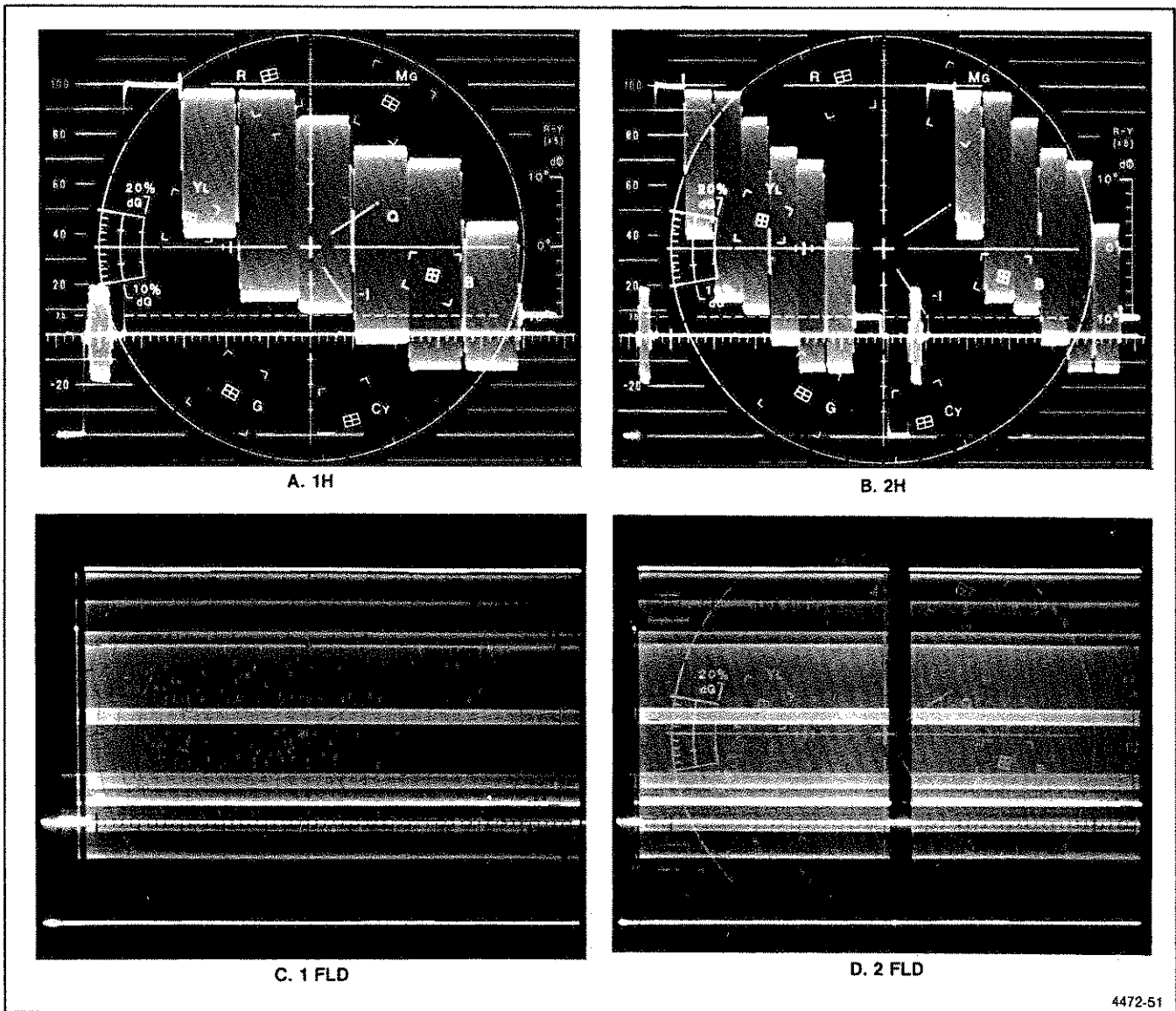

Fig. 2-7. Color Bar signal displayed in each of the sweep rates: A. 1H. B. 2H. C. 1FLD. D. 2FLD.

### 11. Horizontal Magnifier

Select the 2H SWEEP and center the horizontal sync on the screen.

Press the SWEEPS MAG switch and note the magnification of the horizontal sync details. Fig. 2-8 shows a typical example.

Note that the MAG switch is operable for any SWEEP speed. Release the SWEEPS MAG switch.

### 12. Line and Field Select

Press the 1H SWEEPS switch. Press the LINE SELECTOR ON switch. Rotate the LINE SELECTOR switch and look for the first line or half line in the field that contains

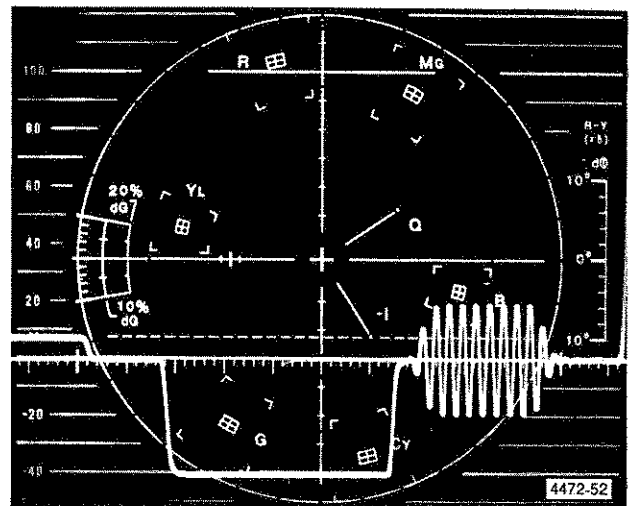

Fig. 2-8. 1 us/Div. display of H (line) sync. 2H SWEEP rate with the MAG on.



Color Bar signal. Press one of the FIELD selection switches and check that the display switches to the opposite situation (half line of Color Bar if a full line was observed or vice versa).

Now set the FIELD select and LINE SELECTOR to display the half line of Color Bars. Push in both FIELD select buttons (ALL) and note that a full line of Color Bar signal is present, with the last half line a little brighter than the first half.

Release the LINE SELECTOR ON button.

This switch combination also selects the line and field for display in the Vector Mode.

### 13. Vector Display

Press the VECTOR switch, and note the vector display, particularly note the position of the center dot.

If necessary, set the dot to the center of the screen (graticule crosshair) using the VECTOR HORIZ POS and VECTOR VERT POS screwdriver-adjustable controls located below the crt.

### 14. Vector Phase

Turn the PHASE control. Note that the vector display can be rotated 360°.

Set the burst vectors to the proper graticule position. Note that the Color Bar vectors lie within their boxes as shown in Fig. 2-9.

### 15. Vector Gain

The X5 and VARIABLE GAIN controls can be used in the Vector Mode to display 100% Color Bars and to set up for differential gain and phase measurements.

Turn the VARIABLE GAIN control out of its detent and adjust it through its range. Notice the effect on the display.

Adjust the VARIABLE GAIN control for minimum amplitude, and press the X5 GAIN switch. Notice the enlarged display.

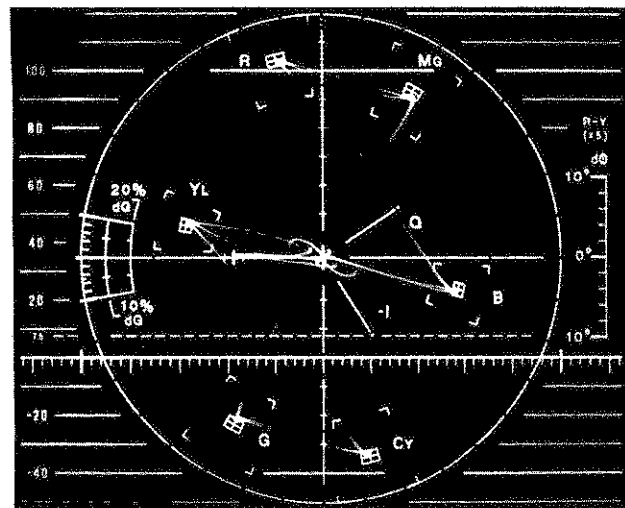

A. NTSC (1750)

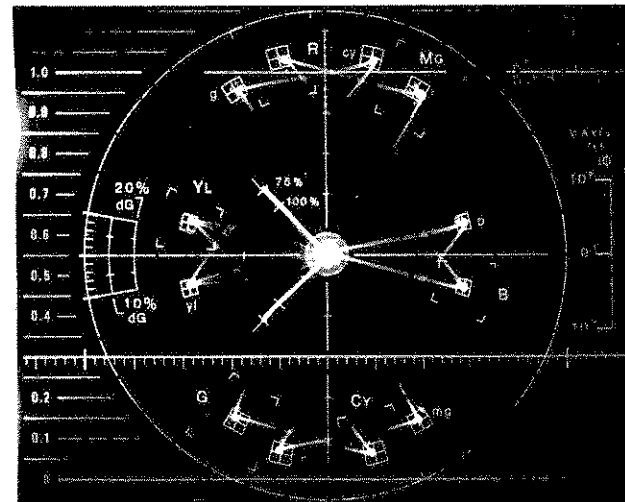

B. PAL (1751)

4472-53

Fig. 2-9. Display of color bar vectors: A. NTSC (1750). B. PAL (1751).

Return the VARIABLE GAIN control to its detent position and release the X5 GAIN switch, obtaining a calibrated display of normal amplitude.

Set the color bar generator for 100% amplitude Color Bars and note that the burst vectors remain the same length while the Color Bar vectors increase in length. Use the VARIABLE GAIN control to place the tip of the burst vector (vectors in 1751) on the 100% burst crosshairs. Now check to see that the Color Bar vector tips are in target boxes. Return the VARIABLE GAIN control to its detented position.

Reset the generator for 75% Color Bars.

### 16. +V/PAL Display (1751)

The 1751 has a +V/PAL switch that inverts the phase of alternate lines so that the display appears similar to an NTSC vector display, but with a single +V burst. Phase differences between lines can be measured using this feature.

Set the +V/PAL switch for +V (switch in), and adjust the PHASE control for a +V display as shown in Fig. 2-10.

Return the +V/PAL switch to PAL (switch out).

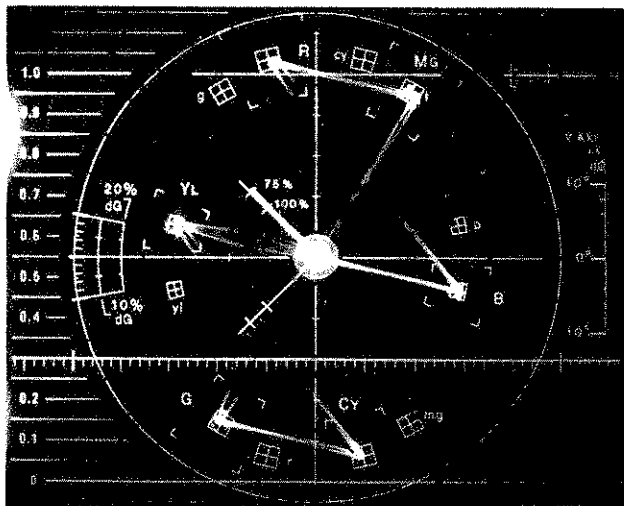

4472-54

Fig. 2-10. The +V display of the PAL Color Bar signal (1751 only).

### 17. R-Y (V-Axis) Display

The R-Y (for the 1750) or V-Axis (for 1751) Mode produces an R-Y versus time display. This mode is used to measure differential phase.

Set the monitor to the CH-B Input (Modulated Staircase). In the Vector Mode, set the phase and amplitude to the appropriate graticule markings for the signal as shown in Fig. 2-11a. If necessary, adjust the VARIABLE GAIN control to place the vector dot on the graticule mark. This calibrates the signal for the differential phase measurement.

Press the R-Y (or V-Axis) and X5 GAIN switches. Adjust the PHASE control as necessary to set the phase at the maximum or minimum part of the line to zero. Use the markings at the right side of the graticule to measure differential phase, if any. See Fig. 2-11b.

Release the X5 GAIN switch.

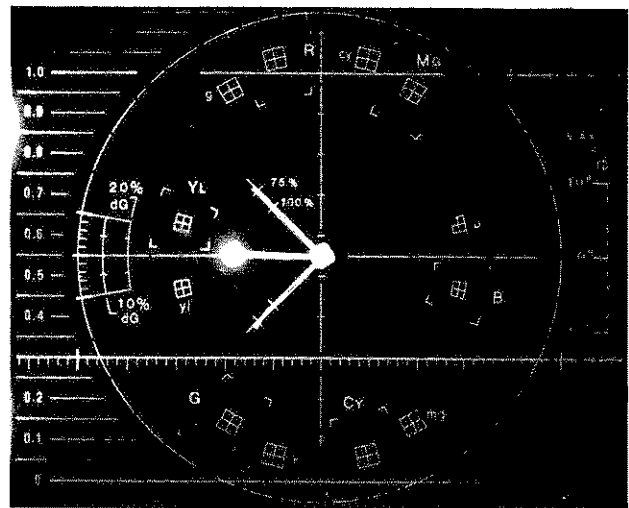

A.

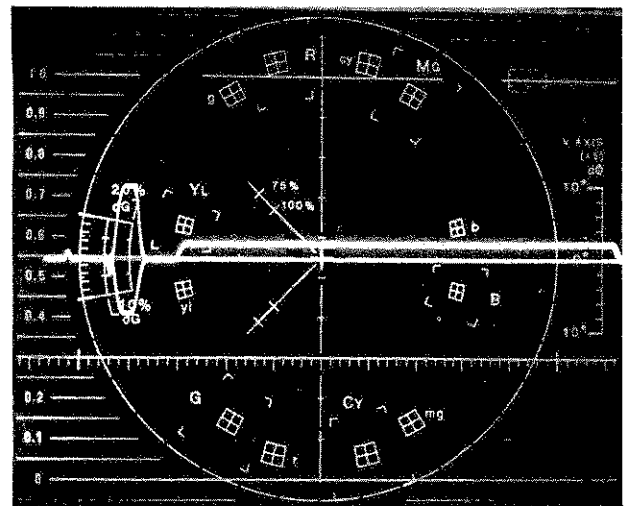

B.

4472-55

Fig. 2-11. Differential Phase measured in the R-Y (V-Axis) Mode: A. Setup. B. Measurement.

### 18. SCH Mode

The 1750-Series Monitors can be used to measure SCH Phase in the SCH Mode. Fig. 2-12 shows a properly SCH phased signal as it would appear on the monitor.

Select INPUT A and SCH and note that a display similar to Fig. 2-12 is present. Rotate the 1750-Series PHASE control through its range and check that the burst and sync vectors can be rotated 360°.

Simultaneously press both VECTOR and SCH and note that the Color Bar vectors are now present along with the SCH sync and burst vectors.

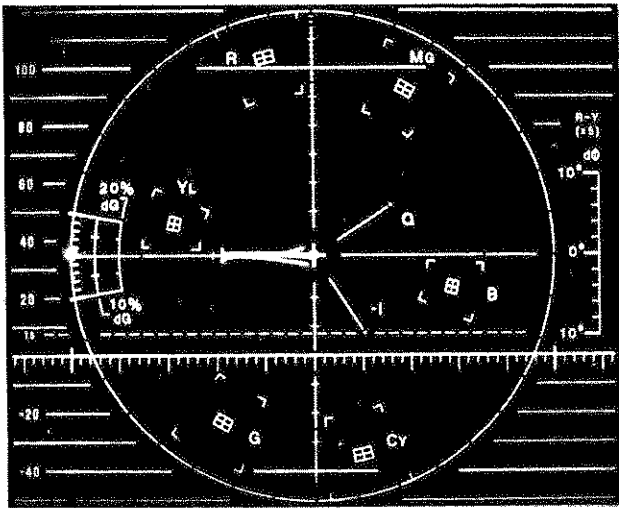

A. 1750

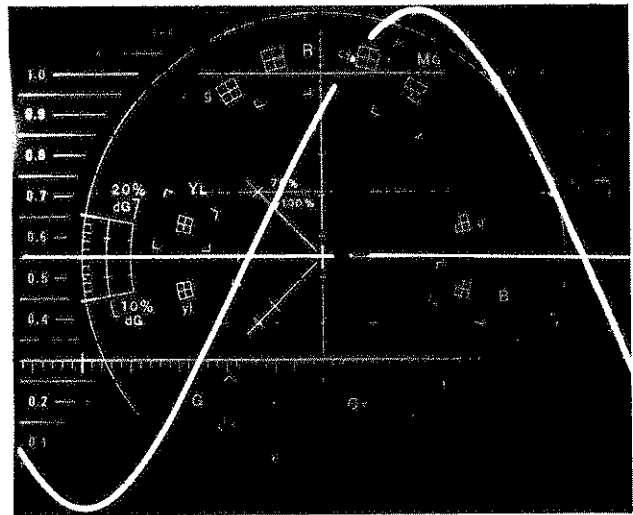

A. PAL

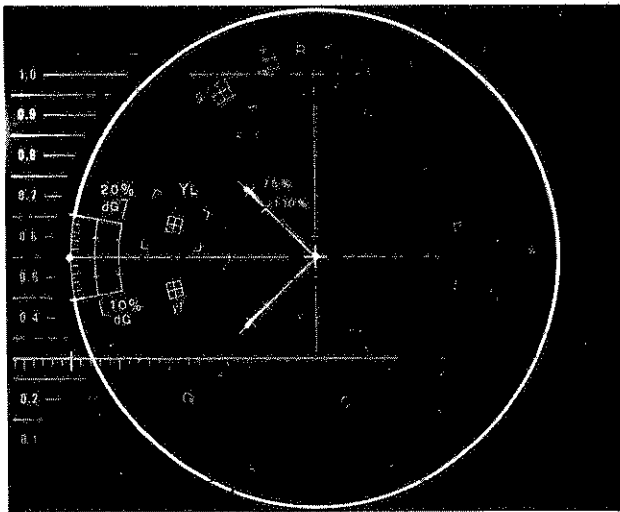

B. 1751

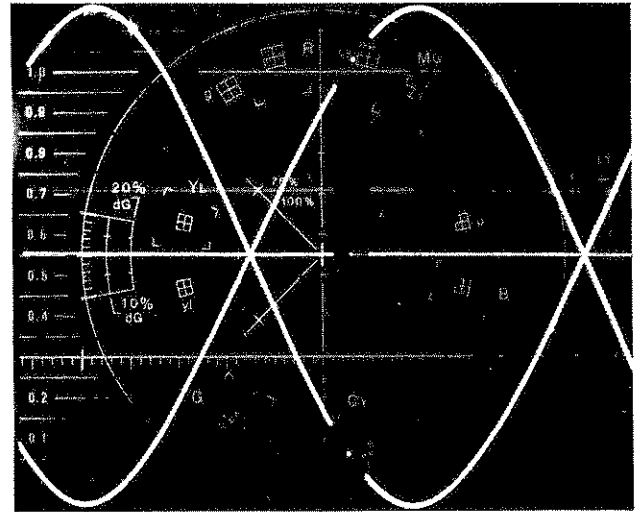

B. +V

4472-56

4472-57

Fig. 2-12. Properly SCH-Phased signal displayed on: A. 1750 B. 1751.

Fig. 2-13. PAL signal displayed in the V-Axis Mode: A. +V/PAL in PAL position. B. +V/PAL in +V position.

(1751 Only.) Press the 2FLD button. Simultaneously press the SCH and R-Y (V-Axis) buttons and check for a sine wave display. This occurs because of the 25-hz offset. See Fig. 2-13. Press the V/PAL button and check for a display of opposed sine waves.

Pressing the WFM and SCH buttons simultaneously selects AFC sync so that sync jitter can be evaluated.

Simultaneously push the WFM and SCH buttons and note that only one sync pulse, which is in the middle of the screen, is displayed.

## APPLICATION INFORMATION

A short description of color video signal degradations and timing is important in understanding the measurement capabilities of this instrument. Signal distortion, when severe enough to degrade the transmitted picture enough to be noticeable on the receiving end, is highly objectionable. The 1750-Series Monitor is used to measure the basic signal characteristics and major associated distortions, thereby making it possible to identify and act on objectionable distortions.

## Signal Degradations

The combination of the luminance and chrominance signals gives rise to several possible degradations. The 1750-Series has several display modes that are used to measure the amount of these degradations.

**Frequency Response.** The frequency response of the video signal path is important in several aspects. If the response at the subcarrier frequency is different than that at lower luminance frequencies, the picture will not appear to have the same amount of color information as the original scene. If the response to the lowest frequencies is not the same as middle range frequencies, tilts will occur in the luminance signal that make the comparison of black areas inaccurate. Frequency response problems may also change the signal transitions so that edges in the scene will not be accurately represented. The FLAT response mode and the low transient distortion of the 1750-Series instruments aid in these measurements.

**Amplitude and Phase.** Because the chrominance components are added together, they suffer degradations like a polar coordinate signal. A reference burst at the subcarrier frequency is included during the horizontal blanking period of the composite television signal. The 1750-Series demodulates the chrominance signal with respect to this reference. In the Vector Mode, the demodulated R—Y (V) signal is used for vertical crt deflection and the demodulated B—Y (U) signal is used for horizontal crt deflection.

The Vector display is very useful in analyzing a number of degradations that occur. Angular movements represent chrominance phase, or hue, changes. Radial movements represent chrominance amplitude changes.

A television picture may have any hue or amplitude within the dynamic limits of the system. Therefore, known test signals are used for system evaluation. If the picture does not have the correct phase relation to the burst reference, the color bar test signal vectors and the burst vectors will not fall at their correct relative locations. This indicates that the hue of the program signal is incorrect. Also, if the color bar chrominance amplitude does not fall within the graticule markings, the program signal color amplitude is incorrect.

**Differential Gain and Phase.** The two major distortions that affect the chrominance signal are differential gain and differential phase.

Differential gain is a change in color subcarrier amplitude due to a change in the luminance signal. In the reproduced picture, chrominance amplitude will be distorted in different areas of the scene due to the luminance variations.

Differential phase is a phase change of the chrominance signal due to a change in the luminance signal. In the reproduced picture, the hue will vary with scene brightness.

If the signal has suffered differential gain or differential phase distortion, the linearity staircase test signal chrominance will show the change in amplitude or phase.

Differential gain and differential phase may occur separately or together. Both can be measured in the Vector Mode. The Waveform Mode (WFM) using the CHROMA FILTER can improve the resolution of the differential gain measurement. The R—Y (V-Axis in the 1751) Mode can be used for improved measurement resolution of differential phase distortions.

These distortions are symptoms of amplifier nonlinearities aggravated by luminance amplitude variations.

## SCH Phase

The M, I, and B scanning systems were originally developed to provide interlaced monochrome television systems. When coloring signals are added a new set of considerations becomes apparent. Namely the relationship of the color subcarrier to the horizontal or line sync, which is referred to as SCH Phase; and the relationship of both horizontal (line) sync and subcarrier to the vertical or field sync, which is referred to as color framing. Slight SCH Phase errors are acceptable, but errors large enough to cause a color framing error cannot be tolerated.

To begin with, color frame errors can be caused by either a horizontal shift, when syncs are out of alignment (blanking width error), or by a 180° burst phase error (hue error). Both of these conditions are noticeable and objectionable. Interlaced scanning provides 525 (System-M) or 625 (System-I or System-B) scanning lines per frame and dividing the frame by 2 leaves a field consisting of 262.5 (System-M) or 312.5 lines (System-I or System-B). The addition of the color subcarrier adds 227.5 cycles (NTSC) or 283.75 cycles (PAL-I or B) of subcarrier per line. At this point a few simple calculations show why there are four or eight scanning fields in one color frame. In the NTSC coloring standard, multiplying the 262.5 lines per field by the 227.5 cycles per line results in 59718.75 cycles of subcarrier per scanning field. After two fields, a complete System-M scanning frame, the subcarrier is 180° out of phase from the start of field one. Therefore, it takes four complete scanning fields to again start field one with the correct sync-to-subcarrier phase relationship. Similarly, the PAL coloring system requires eight scanning fields to return to the correct subcarrier-to-scanning field relationship.

SCH Phase is the extrapolated relationship of horizontal sync phase-to-color subcarrier phase. If subcarrier reference were continuous, measurement of this relationship would be simple (as shown in Fig. 2-14). However, since burst does not occur during horizontal sync, extrapolation is required.

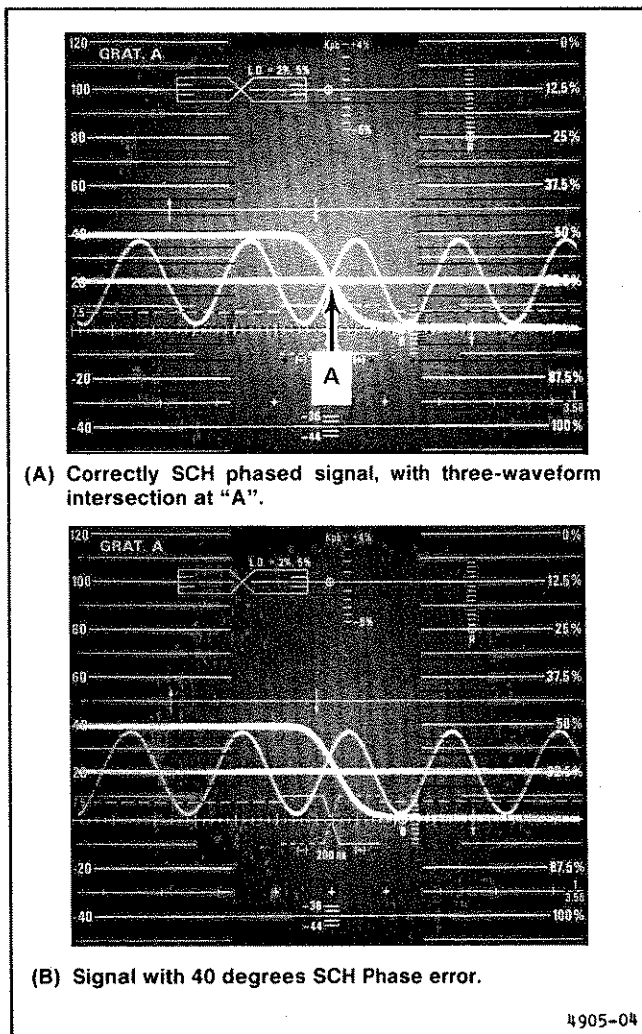

Fig. 2-14. An example of SCH Phase extrapolation. Note that the measurement point is at blanking.

The key elements in this measurement are the 50% amplitude point on the leading edge of sync and its phase difference from a finite number of reference subcarrier cycles. SCH Phase error is expressed in degrees and is read out by the 1750-Series on the vector graticule compass rose. See Fig. 2-15.

### Signal Timing

The timing of the signal can be measured using the timebase of the 1750-Series in the Waveform Mode (WFM) and the R-Y (1750) or V-Axis (1751) Mode. The 1H and 2H MAGnified SWEEPS are calibrated to 0.2 and 1  $\mu$ s/div. The 2FLD MAG SWEEP is useful for examining the vertical inter-

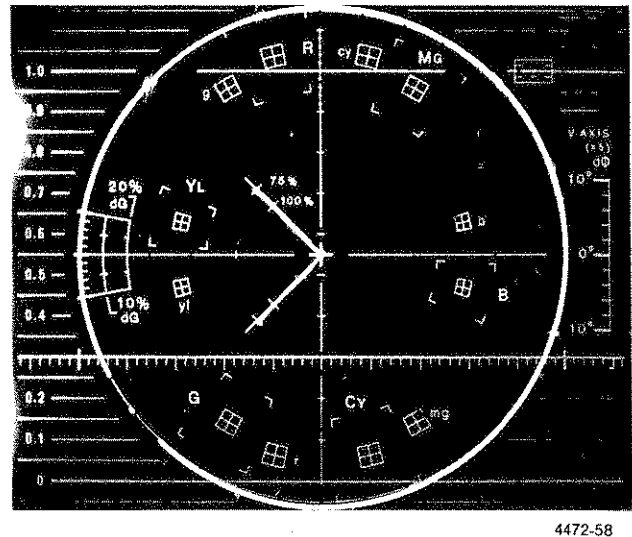

Fig. 2-15. An SCH Phase measurement of a signal containing a 40° error.

val of the composite video signal. One or two lines in the vertical interval may be displayed using the FIELD and LINE SELECTOR. The line or lines are displayed in the 1H, 2H, 1FLD, or 2FLD SWEEP using the WFM or R-Y (V-Axis) Modes. In the Vector Mode, one line from each of the odd or even fields, depending on the setting of the FIELD select, are overlaid and displayed.

## GRATICULES

The 1750-Series employs an internal combination waveform and vector graticule. The advantage of the internal graticule is that the scales are on the same plane as the crt phosphor, and thus eliminate parallax errors when viewing and photographing displays. The scale brightness is adjustable by the front-panel SCALE ILLUM control.

### Waveform Graticule

Two basic patterns are included on the waveform monitoring scales for the internal graticules for the 1750-Series Monitors.

1. NTSC Composite Video graticule for the 1750 (shown in Fig. 2-16a).

2. CCIR Composite graticule for 1751 PAL instruments (shown in Fig. 2-16b).

### NTSC and CCIR Horizontal Scales

The horizontal reference line at 0 IRE (NTSC) or 0 V (CCIR) is 12.7 divisions long. With the SWEEP switch set to 1H or 2H, the width of the display is one or two television

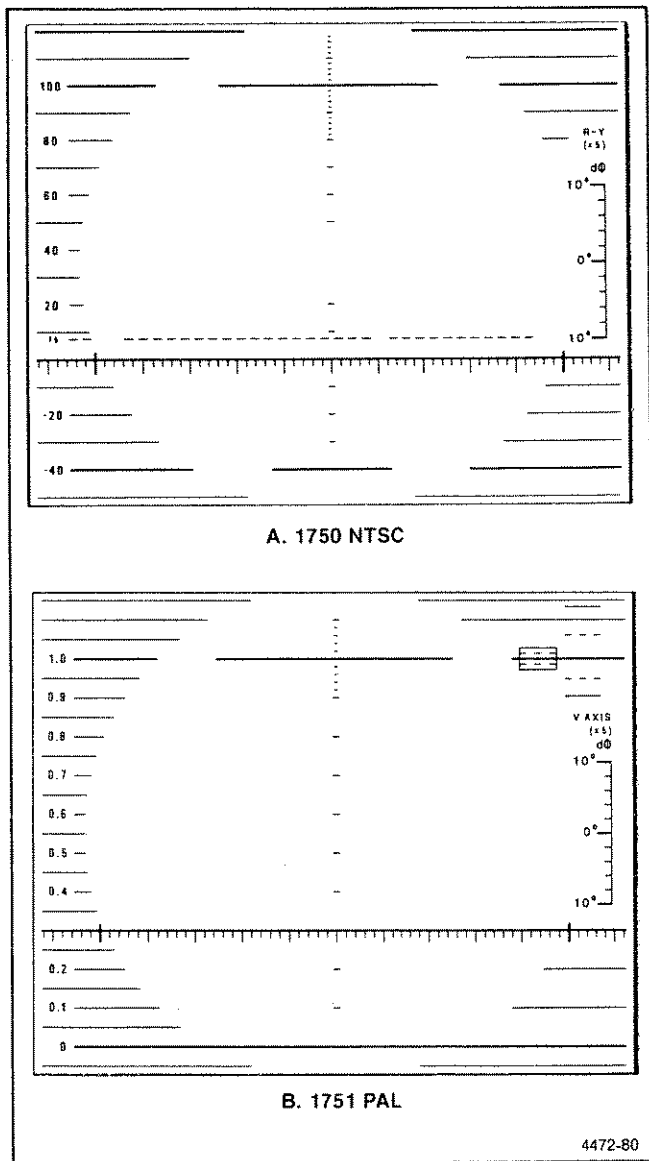

Fig. 2-16. Waveform portion of the 1750-Series composite graticules: A. 1750. B. 1751.

lines. For 1FLD or 2FLD the width is one or two television fields. When the SWEEP MAG switch is selected with 1H or 2H, each major division represents  $0.2 \mu\text{s}$  or  $1 \mu\text{s}$ , respectively, and can be used for a time calibration check.

### NTSC Vertical Scales (1750 Only)

The NTSC graticule has a vertical scale in IRE units for standard waveform amplitude measurements. One IRE unit is equivalent to  $7.14 \text{ mV}$ , which is one percent of peak white. The IRE scale is labeled every twenty IRE units between  $-40$  and  $+100$  IRE, but marked with horizontal lines every 10 IRE from  $-50$  to  $+120$  IRE. An additional line at 7.5 IRE units is provided for a black level setup reference.

The vertical scale can be used to measure transmitter percent of modulation. The zero carrier level is the 120 IRE unit line (at the top of the graticule), 12.5% (or peak white) is at the 100 IRE line, 75% at the 0 IRE line, and 100% modulation (at the sync tip) is the  $-40$ -IRE unit line.

**Measuring Amplitudes of Less Than 10 IRE.** An additional vertical scale is provided at the horizontal centerline of the crt. It is divided in 2-IRE increments between  $+80$  and  $+120$  IRE. The following steps show how it can be used to measure Pulse-to-Bar Ratio.

1. Set the waveform blanking level on the 0 IRE line. If line tilt is present, select a point near the center of the signal as the blanking level reference point.

2. If insertion gain is not correct, set the VAR GAIN control so that center of the bar top passes through the 100 IRE line at the graticule center.

3. Use the HORIZ POS to move the bar top across the scale at graticule center. Check the largest deviation of the bar top, excluding the first and last  $\mu\text{sec}$ .

4. Set the center of the  $18 \mu\text{s}$  bar ( $16 \mu\text{sec}$ ) on the graticule center scale and adjust VAR GAIN, if necessary, for exactly 100 IRE. (If bar tilt is present use the center of the bar as the average bar amplitude.) Then use the HORIZ POS control to move the pulse peak to the graticule center scale. Check the amplitude of the pulse against the scale.

Since bar amplitude is 100% the scale also reads out directly in percent. For example: If the bar amplitude is 100 IRE (100%) and the pulse amplitude is 96 IRE then the pulse-to-bar ratio is 0.96 to 1 (96%).

### CCIR Vertical Scales (1751)

The CCIR waveform portion of the internal graticule has a 0 to 1 V scale, marked in 100 mV increments on the left side. The lines at 0 V,  $+0.3 \text{ V}$ , and  $1.0 \text{ V}$  are bolder than other lines for easy reference to the sync tip, blanking, and peak white levels.

### CCIR K Factor Scales (1751)

A target scaled in  $\pm 2\%$  and  $\pm 4\%$  K factor increments vertically, with a width of  $8 \mu\text{s}$  is located to the right side of the graticule. When the  $10\text{-}\mu\text{s}$  bar is centered over the target, bar tilt can be read directly. The target, when used this way, ignores the first and last microsecond of the bar, where short time distortions may be observed.

The short dashed and solid lines, immediately to the right of the K Factor target, provide 5% and 10% K Factor scales for pulse-to-bar measurements.

## VECTOR GRATICULES

The xy display permits measurements of chrominance. Hue is measured in terms of relative phase of the chrominance signal with respect to the colorburst. Relative amplitude of chrominance is the length of the vectors. Each vector target is set up to measure 75% amplitude chrominance for the particular color of the color bar test signal.

### NTSC Vector Targets (1750)

On the vector graticule each color bar chrominance vector terminates in a system of graticule targets. See Fig. 2-17a. The dimensions of the larger targets equal  $\pm 10^\circ$ , centered on the exact chrominance phase, and  $\pm 20\%$  of the chrominance amplitude, centered around 75% amplitude color bar signal. The smaller targets represent  $\pm 2.5^\circ$  of chrominance phase and 2.5 IRE chrominance amplitude.

### PAL Vector Targets

On the PAL vector graticule (1751) each chrominance vector related to the +V burst terminates in a target. (See Fig. 2-17b.) The outer target dimensions are equal to  $\pm 10^\circ$

centered on the exact chrominance phase and  $\pm 20\%$  of chrominance amplitude centered around the standard 75% amplitude, 0% setup color bar signal. The center target is equal to  $\pm 3^\circ$  chrominance phase and  $\pm 5\%$  of chrominance amplitude.

The chrominance vectors associated with the -V burst use  $3^\circ$ , 5% targets only. These targets are further differentiated by lower case labels.

The 1750 vector graticule has  $\pm 10\%$  burst amplitude tolerance marks on the B-Y axis. The 1751 has 75 and 100% amplitude burst marks. If 100% amplitude bars are to be displayed, VARIABLE GAIN control can be adjusted to place the tip of the burst vectors on 100% marks and the vector tips should then fall on their targets.

### Bandwidth Calibration Aid

The horizontal and vertical axes, of the vector graticule, contain markings for checking Vector Mode bandwidth. A subcarrier frequency sine wave whose amplitude places it on the outer compass rose is used as a reference. When the frequency is changed the diameter of the circle should reduce. At a point equal to 70% of full amplitude (3 dB) there are gaps in the horizontal and vertical axes. This calibration aid makes it possible to check the -dB points of the monitor's demodulator output amplifiers.

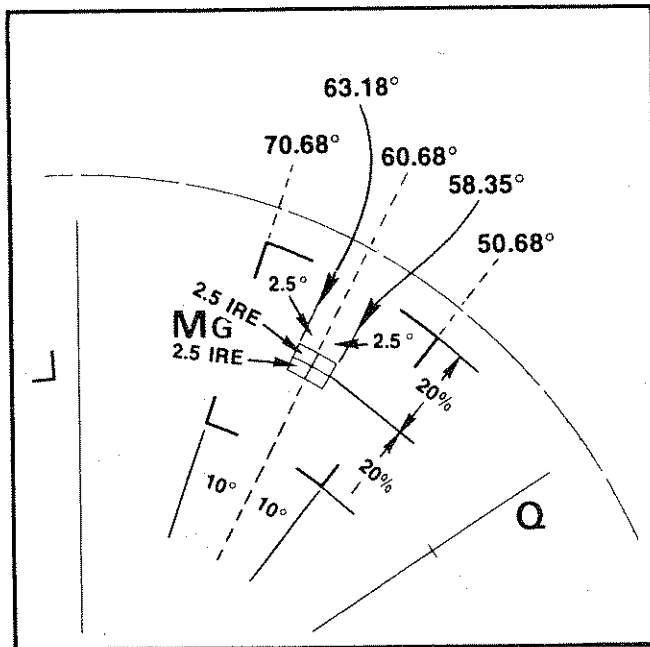

A. 1750 NTSC MAGENTA TARGET

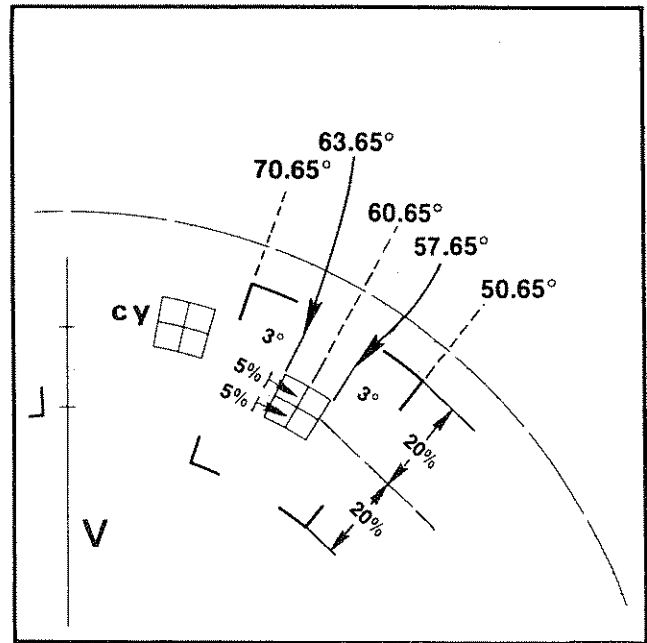

B. 1751 PAL MAGENTA TARGET

4472-71

Fig. 2-17. Interpreting the vector graticule: A. 1750 (NTSC). B. 1751 (PAL).

## DIFFERENTIAL GAIN AND PHASE MEASUREMENTS

### Differential Gain/Differential Phase Scales

There is a special differential gain and differential phase measurement scale located at the left side of the B—Y

(U-Axis for PAL). It is specially scaled for use in the Vector Mode, and provides direct measurement of up to 20% differential gain error and 10° differential phase error. See Fig. 2-18 for a typical differential gain measurement and Fig. 2-19 for a typical differential phase measurement illustration.

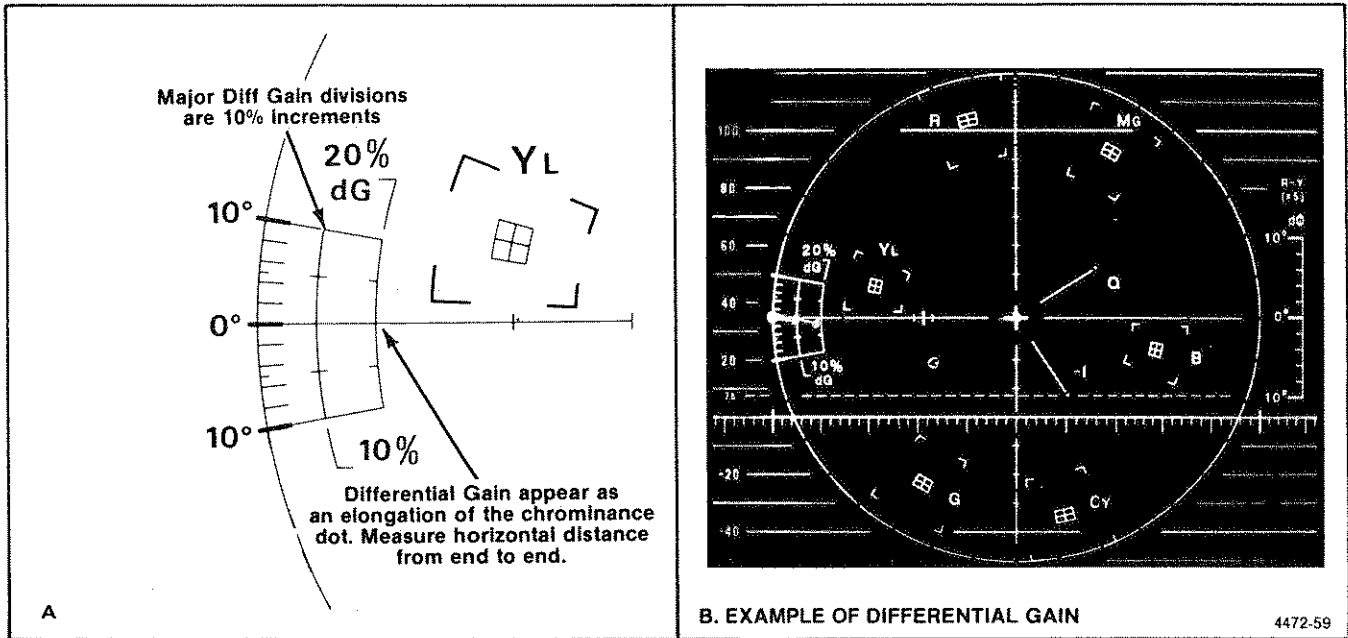

Fig. 2-18. Interpreting a differential gain measurement.

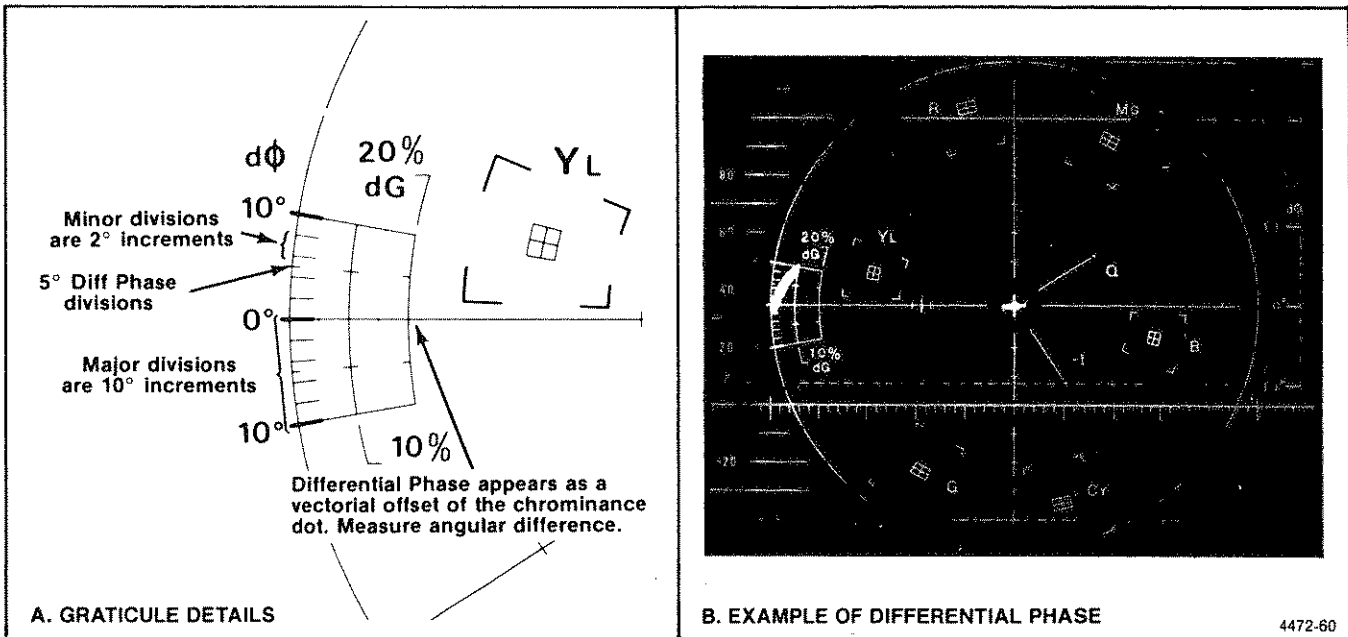

Fig. 2-19. Interpreting a differential phase measurement.





## **WARNING**

THE FOLLOWING SERVICING INSTRUCTIONS ARE FOR USE BY QUALIFIED PERSONNEL ONLY. TO AVOID PERSONAL INJURY, DO NOT PERFORM ANY SERVICING OTHER THAN THAT CONTAINED IN OPERATING INSTRUCTIONS UNLESS YOU ARE QUALIFIED TO DO SO. REFER TO OPERATORS SAFETY SUMMARY AND SERVICE SAFETY SUMMARY PRIOR TO PERFORMING ANY SERVICE.



# PART II SERVICE INFORMATION

## SERVICE SAFETY SUMMARY

### FOR QUALIFIED SERVICE PERSONNEL ONLY

*Refer also to the preceding Operators Safety Summary.*

#### Do Not Service Alone

Do not perform internal service or adjustment of this product unless another person capable of rendering first aid and resuscitation is present.

#### Use Care When Servicing With Power On

Dangerous voltages exist at several points in this product. To avoid personal injury, do not touch exposed connections and components while power is on.

Disconnect power before removing protective panels, soldering, or replacing components.

#### Power Source

This product is intended to operate from a power source that will not apply more than 250 volts rms between the supply conductors or between either supply conductor and ground. A protective ground connection by way of the grounding conductor in the power cord is essential for safe operation.

## INSTALLATION

### PACKAGING

At installation time, save the shipping carton and packing materials in the event additional instrument movement is necessary. See Repackaging for Shipment in Section 6 for detailed repackaging instructions.

#### Accessories

Accessories are packed in a small package inside the 1750-Series shipping carton. The following items should be included with the 1750-Series:

1. Instruction Manual
2. Power Cord
3. 25-Pin Connector assembly
4. 9-Pin Connector assembly
5. Spare fuses.

Standard accessory items are shown and their part numbers listed at the rear of the Replaceable Mechanical Parts list.

### ELECTRICAL INSTALLATION

#### Mains Frequency and Voltage Ranges

The 1750-Series operates over a frequency range of 48 to 66 Hz, and at nominal mains voltages of 115 Vac or 230 Vac. A rear-panel switch is used for voltage selection.

#### **WARNING**

*When changing to 230 Vac operation, use a power cable with appropriate voltage ratings.*

**Power Cord Options**

There are five power cord options orderable with the 1750-Series. If no option is specified the 1750-Series is shipped with the North American 120 V/15 A three prong plug power cord. Fig. 3-1 shows all of the power cord/plug options that can be ordered with the 1750-Series. These power cords can be ordered from a Tektronix, Inc. field office or distributor.

3. Insert a small screwdriver into the switch slot and move it to the other position.
4. Check for proper fuse rating before replacing the fuse.
5. Install correct fuse.

**Mains Conversion**

Mains voltage selection is accomplished by throwing a recessed, slotted slide switch. See Fig. 3-2.

The mains voltage range can be changed as follows:

1. Remove the power cord.
2. Remove the line fuse.

**Trace Rotation Adjustment**

Variations in the earth's magnetic field may require adjusting the Trace Rotation Control (R105 on LV Supply board A6) at installation time, or when the instrument is moved. Check that the trace, in Waveform Mode (without input signal), is properly aligned on the horizontal axis. If it is not, adjust the Trace Rotation (R105) for the proper alignment. The portable case and cabinet (optional accessories) have holes that provide external access to the Trace Rotation Control. Fig. 3-3 shows the location of the control.

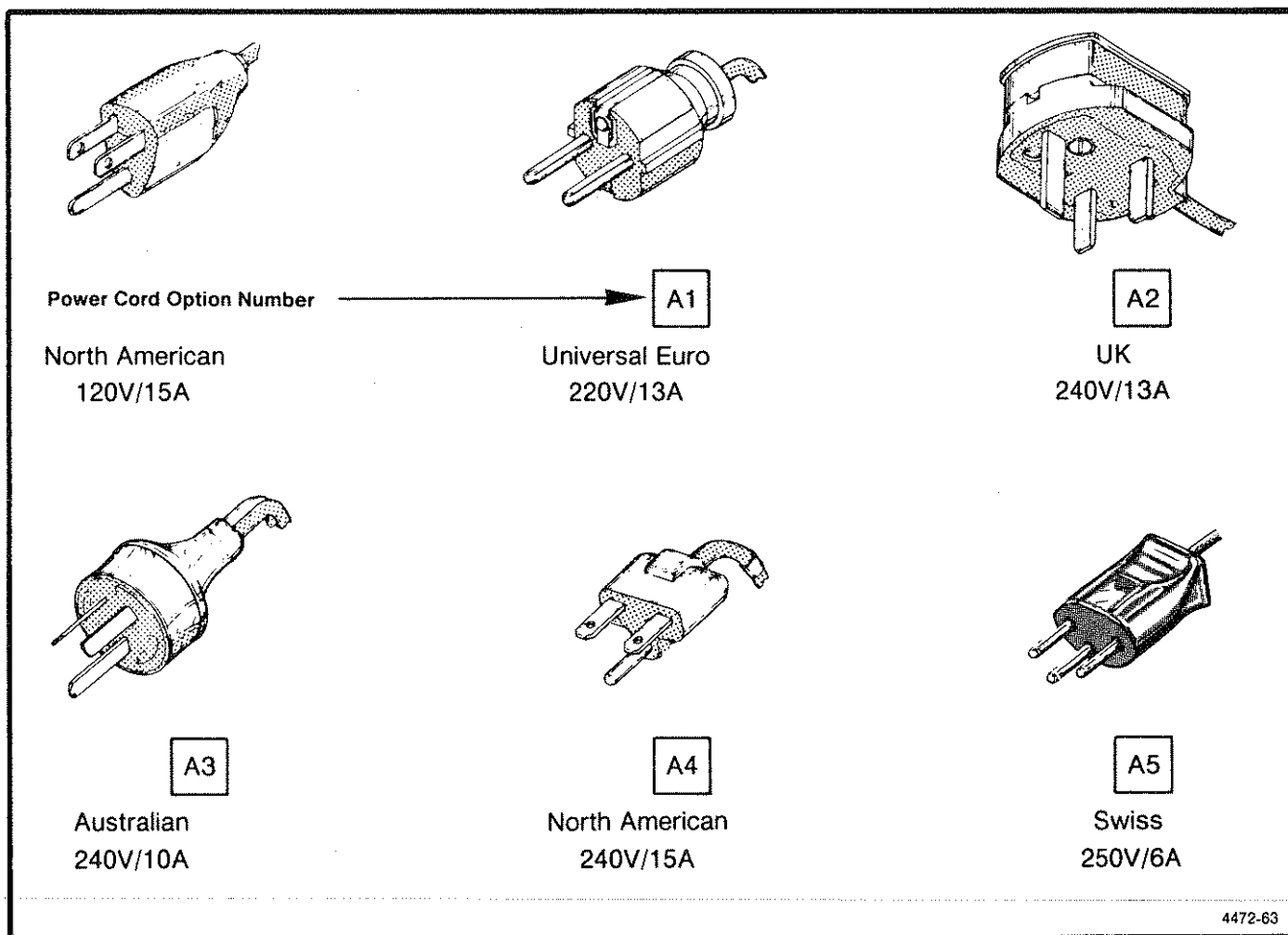

Fig. 3-1. The various power cord options offered for the 1750-Series Waveform/Vector Monitor. Note that the power cord can be identified by the power plug.

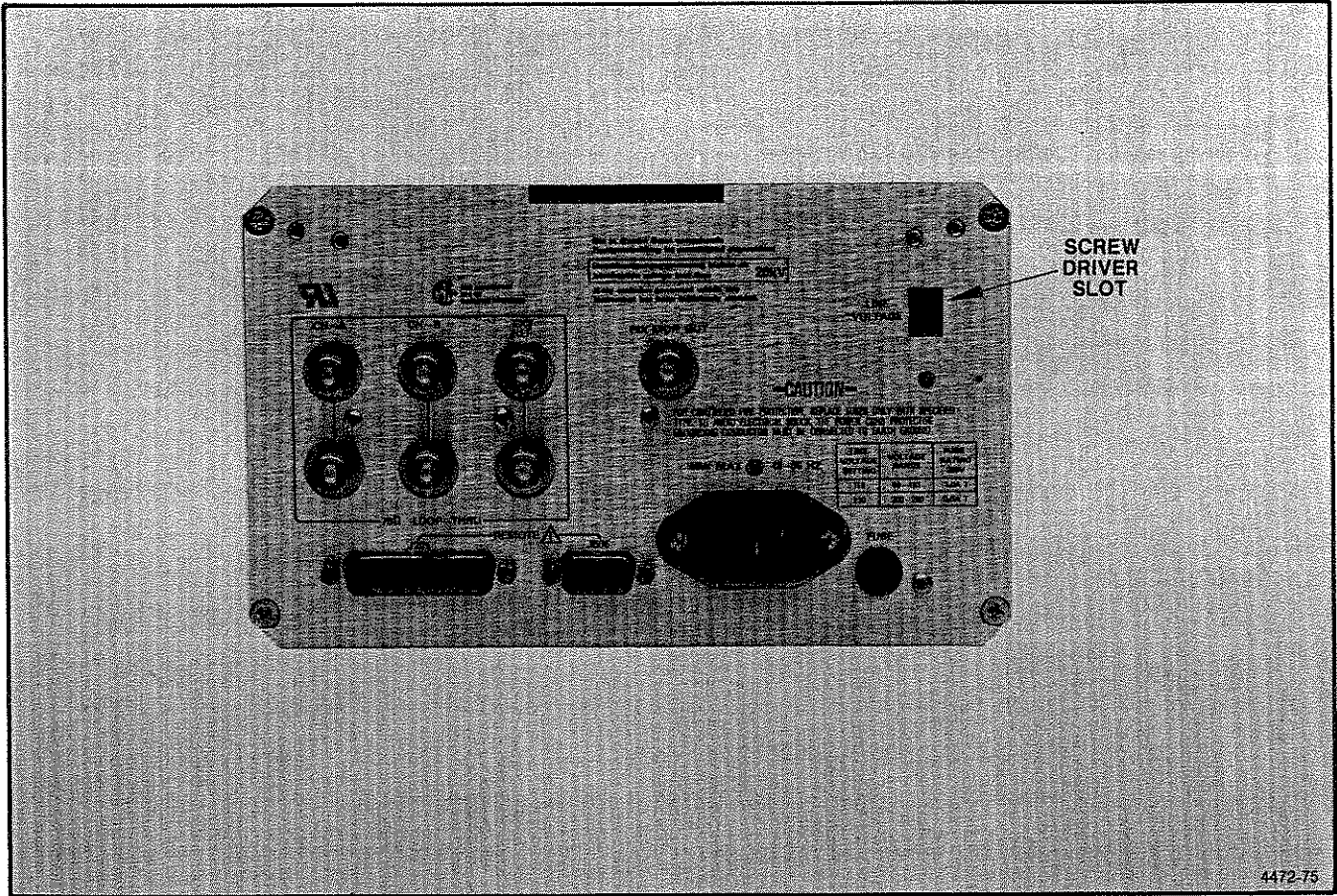

Fig. 3-2. Changing Line Selector switch.

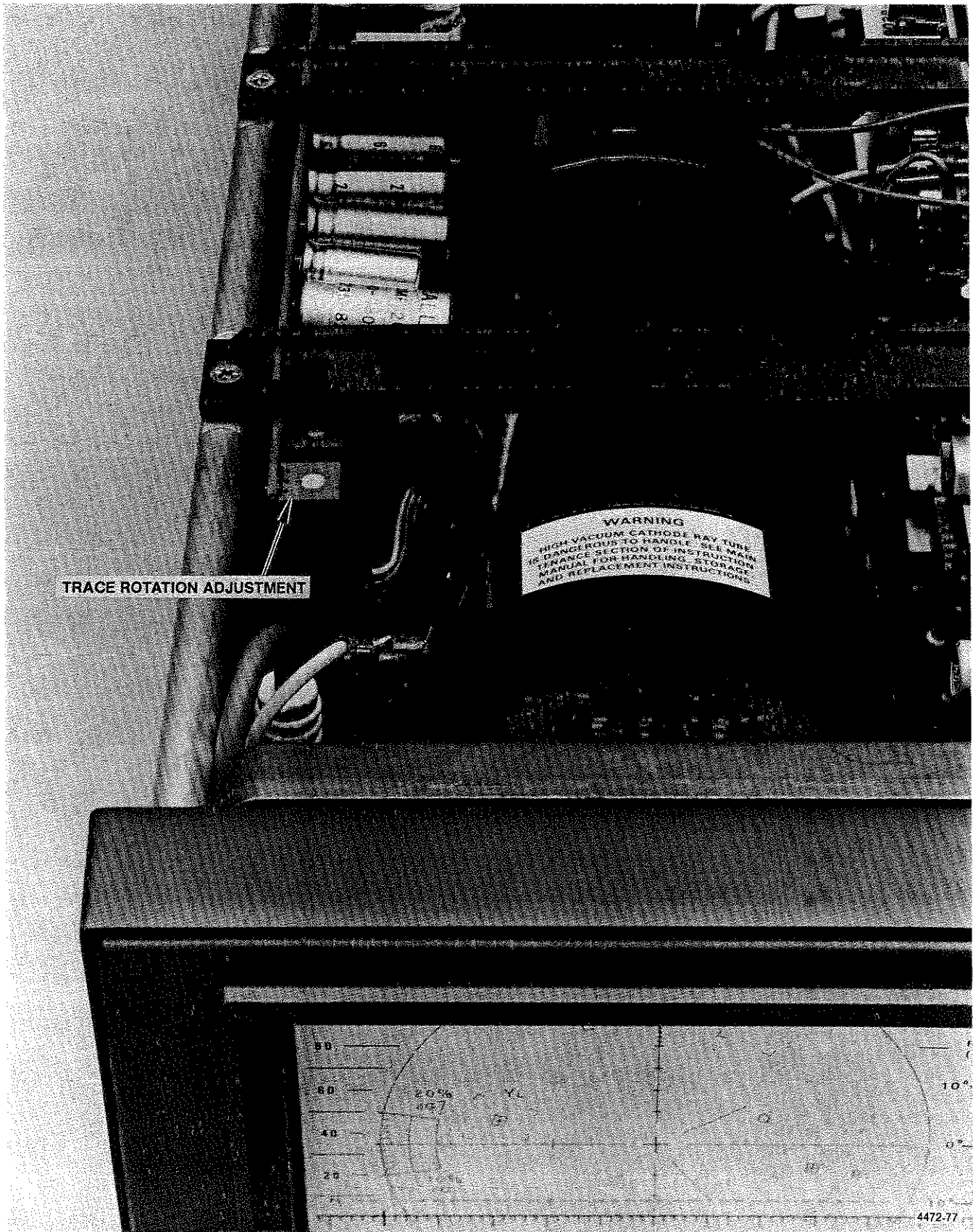

Fig. 3-3. Trace Rotation Adjustment location.

**REMOTE Connections**

The rear-panel REMOTE connectors perform several functions. J205 provides staircase and enable inputs for camera RGB/YRGB displays. It also provides remote control of front-panel switching (except line and field selection), the external blanking input, and Remote Sync input and enable.

J505 is used for REMOTE line and field selection. It provides for the Line Selector enable, five-line select bits, and remote field selection.

Fig. 3-4 shows the REMOTE plugs with each function labeled.

**RGB/YRGB Display.** Some camera control units provide a single video output containing the red (R), green (G), and blue (B) picture components on consecutive lines. The cam-

era control unit supplies a three-step staircase control signal for the RGB display or a four-step signal for the YRGB display and an enable for the parade display.

The 1750-Series reduces the sweep length to one-third its normal length for the RGB parade display. A jumper modification allows further sweep reduction for the YRGB parade display.

**Remote Front Panel**

All front-panel switching, including line and field selection, can be accomplished from a remote source. J505 serves as the line and field selection remote switching interface, while J205 interfaces the other remote switching inputs. Because of the complexity of the line and field selection, it is covered separately.

Table 3-1 is a matrix of the decisions made by pulling interface lines down via ground closure.

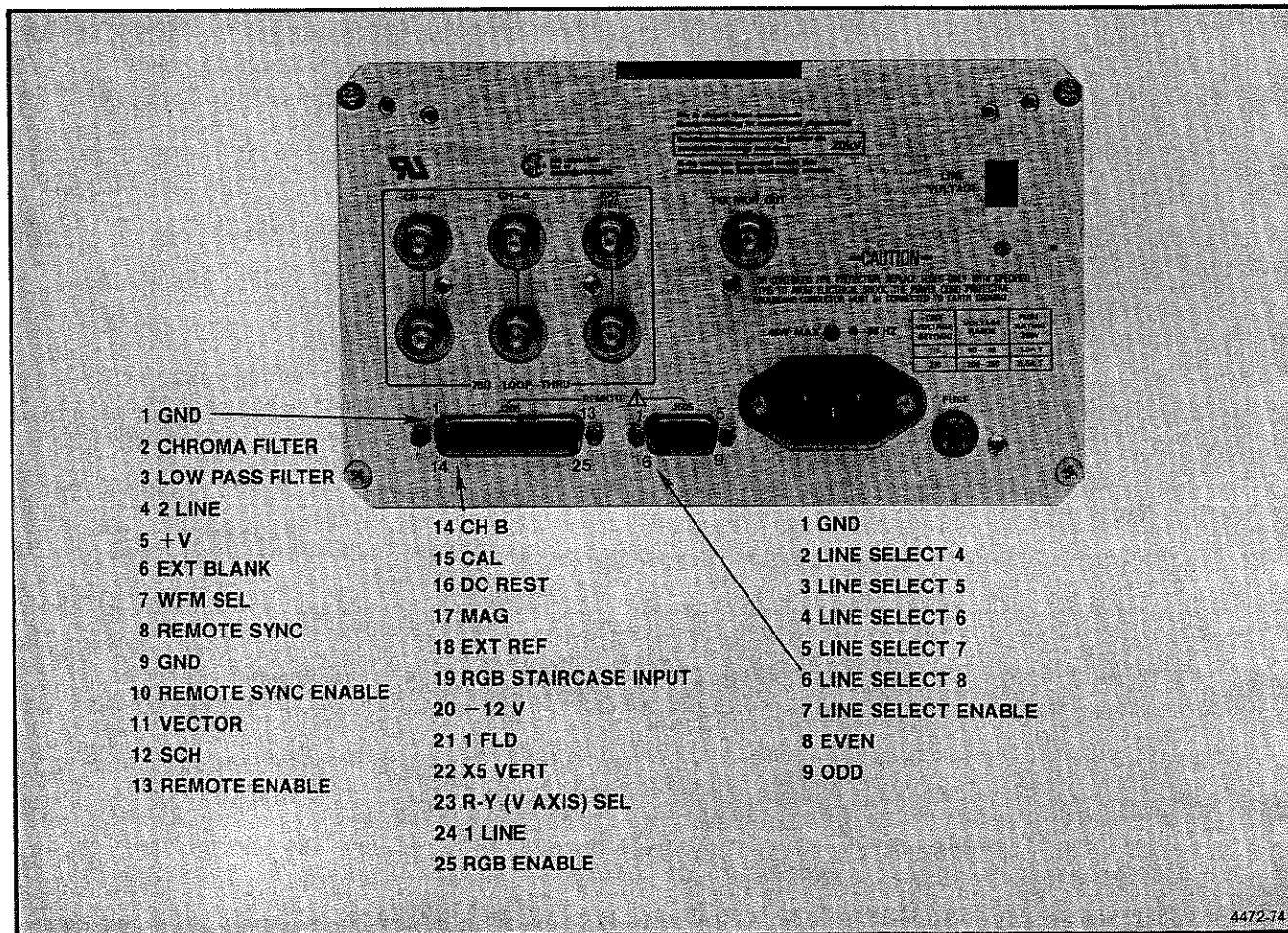

Fig. 3-4. 1750-Series Remote Plug pin assignments.

Table 3-1  
REMOTE FRONT-PANEL SWITCHING

	Affected Remote Pins				1750-Series Operation
	7	23	20	9	
	WFM	R-Y	VECT	SCH	
MODE	L	L	L	L	WFM, AFC, Sync Ctrd.
	L	L	L	H	WFM, AFC
	L	L	H	L	WFM, AFC, Sync Ctrd.
	L	L	H	H	WFM, AFC,
	L	H	L	L	WFM, AFC, Sync Ctrd.
	L	H	L	H	WFM
	L	H	H	L	WFM, AFC, Sync Ctrd.
	L	H	H	H	WFM
	H	L	L	L	R-Y, SCH
	H	L	L	H	R-Y
	H	L	H	L	R-Y, SCH
	H	L	H	H	R-Y
	H	H	L	L	VECTOR, SCH
	H	H	L	H	VECTOR
	H	H	H	L	SCH
	H	H	H	H	VECTOR
		14	15		
		CH-B	CAL		
INPUT		L	L		CAL
		L	H		CH-B
		H	L		CAL
		H	H		CH-A
	24	4	21		
	1H	2H	1FLD		
	L	L	L		1 line sweep
	L	L	H		1 line sweep
	L	H	L		1 line sweep
	L	H	H		1 line sweep
	H	L	L		1 line sweep
	H	L	H		2 line sweep
	H	H	L		1 field sweep
	H	H	H		2 field sweep
		2	3		
		CHROMA	IRE/LUM		
FILTERS		L	L		CHROMA
		L	H		CHROMA
		H	L		IRE or LUM
		H	H		FLAT
		17			
		MAG			
SWEEP MAG		L			Sweep Magnified
		H			Sweep Un-Magnified



## REMOTE FRONT-PANEL SWITCHING (cont)

Affected Remote Pins		1750-Series Operation
	22 5X VERT L H	Vertical 5X Mag. Vertical Normal
DC RESTORER	16 DC REST L H	DC Restorer On DC Restorer Off
REMOTE ENABLE	13 REMOTE ENABLE L H L H	Remote Local Local Remote

**Remote Line and Field Selection**

J505 is the remote line and field selection interface. It has the Line Select Enable, Field Select (Even, Odd), and five most significant bits of the line select word. The four least significant bits are supplied by the front-panel LINE SELECTOR. The front-panel LINE SELECTOR is always active,

even when Remote Line Select is enabled; it selects the line (or lines) for display out of the group of 16 lines. The front-panel LINE SELECTOR indicator always indicates which line is displayed; in the event of 2H sweep it indicates the first line displayed. Tables 3-2 and 3-3 are matrices of the NTSC and PAL remote line selection logic.

Table 3-2  
NTSC REMOTE LINE AND FIELD SELECTION

Remote Lines Affected					Displayed	
Line Select Enable	7 (Enable)				Enabled. Disabled.	
	L H					
Field Select	8 (Even)		9 (Odd)		Odd Field. Even Field. Both Fields. Even Field.	
	H		L			
	H		H			
	L		L			
Line Select	2 (Bit 4)	3 (Bit 5)	4 (Bit 6)	5 (Bit 7)	6 (Bit 8)	Fields Lines
	H	H	H	H	H	Lines 8 thru 23
	H	H	H	H	L	Lines 24 thru 39
	H	H	H	L	H	Lines 40 thru 55
	H	H	H	L	L	Lines 56 thru 71
	H	H	L	H	H	Lines 72 thru 87
	H	H	L	H	L	Lines 88 thru 103
	H	H	L	L	H	Lines 104 thru 119
	H	H	L	L	L	Lines 120 thru 135
	H	L	H	H	H	Lines 136 thru 151
	H	L	H	H	L	Lines 152 thru 167
	H	L	H	L	H	Lines 168 thru 183
	H	L	H	L	L	Lines 184 thru 199
	H	L	L	H	H	Lines 200 thru 215
H	L	L	H	L	Lines 216 thru 231	
H	L	L	L	H	Lines 232 thru 247	
Field 1 and 3	H	L	L	L	L	Lines 248 thru 263
Field 2 and 4	H	L	L	L	L	Lines 248 thru 262 and CCC <sup>a</sup>
	L	H	H	H	H	Lines 2 thru 7

<sup>a</sup>CCC = Unselectable line.

Table 3-3  
PAL REMOTE LINE AND FIELD SELECTION

Remote Lines Affected					Displayed	
Line Select Enable	7 (Enable)				Enabled. Disabled.	
	L					
Field Select	8 (Even)		9 (Odd)		Field 2 and 4. Field 1 and 3. Both Fields. Field 1 and 2.	
	H		L			
	H		H			
	L		L			
L		H				
2 (Bit 4)	3 (Bit 5)	4 (Bit 6)	5 (Bit 7)	6 (Bit 8)	Fields	Lines
H	H	H	H	H	2-4	319-334
H	H	H	H	L	1-3	22-37
H	H	H	H	L	2-4	335-350
H	H	H	L	H	1-3	38-53
H	H	H	L	H	2-4	351-366
H	H	H	L	L	1-3	54-69
H	H	H	L	L	2-4	367-382
H	H	L	H	H	1-3	70-85
H	H	L	H	H	2-4	383-398
H	H	L	H	L	1-3	86-101
H	H	L	H	L	2-4	399-414
H	H	L	L	H	1-3	102-117
H	H	L	L	H	2-4	415-430
H	H	L	L	L	1-3	118-133
H	H	L	L	L	2-4	431-446
H	L	H	H	H	1-3	134-149
H	L	H	H	H	2-4	447-462
H	L	H	H	L	1-3	150-165
H	L	H	H	L	2-4	463-478
H	L	H	L	H	1-3	166-181
H	L	H	L	H	2-4	479-494
H	L	H	L	L	1-3	182-197
H	L	H	L	L	2-4	495-510
H	L	L	H	H	1-3	198-213
H	L	L	H	H	2-4	511-526
H	L	L	H	L	1-3	214-229
H	L	L	H	L	2-4	527-542
H	L	L	L	H	1-3	230-245
H	L	L	L	H	2-4	543-558

PAL REMOTE LINE AND FIELD SELECTION (cont)

Remote Lines Affected						Displayed
H	L	L	L	L	1-3	246-261
H	L	L	L	L	2-4	559-574
L	H	H	H	H	1-3	262-277
L	H	H	H	H	2-4	575-590
L	H	H	H	L	1-3	278-293
L	H	H	H	L	2-4	591-606
L	H	H	L	H	1-3	294-309
L	H	H	L	H	2-4	607-622
L	H	H	L	L	1-3	310-313 & 2-5
L	H	H	L	L	2-4	623-625, CCC, <sup>a</sup> & 315-318

<sup>a</sup>CCC = Unselectable line.

**External Blanking.** When pulled low in any mode, the External Blanking input blanks the display. It can be used with a blanking signal generated by other equipment to display selected lines or parts of lines, or during calibration for sweep generator markers. It works in conjunction with the internal blanking signals. All blanking inputs must agree for unblanking.

**Remote Sync Input.** An external reference may be applied through the REMOTE connector. Fig. 3-4 shows the Remote Sync and Remote Sync Enable inputs. When pin 10 of the REMOTE connector is pulled to a TTL low, or grounded, the Remote Sync input is selected. The EXT REF switch is overridden when the Remote Sync is enabled. This input should be used for non-video reference signals. The switching threshold is factory set for +1 V with 10K termination, edge selection is jumper selectable.

**Operational Changes**

Several instrument features can be modified by changing internal jumpers or switches.

**Input Coupling.** The video input channels are factory set to be ac coupled. Dc coupling may be desired for viewing some types video signals. Input coupling is changed by moving plug jumpers for J207 and/or J403 on the Vertical board (A3). The selections are:

- CH-A P207 Pins 1-2 AC (factory set)  
Pins 2-3 DC
- CH-B P403 Pins 1-2 AC (factory set)  
Pins 2-3 DC

**DC Restorer Sample Timing.** As factory supplied, the DC Restorer clamps on selected reference during back porch time. The clamp level may be sampled during the sync tip when the source is the internal reference only. Sync tip sampling is selected by changing the plug jumper for J190 on the SCH Logic board (A9). The selections are:

- P190 Pins 1-2 Back Porch (factory set)  
Pins 2-3 Sync Tip

External source is selected by changing the plug jumper for J188 on the SCH Logic board (A9). The selections are:

- P188 Pins 1-2 Internal  
Pins 2-3 Selected Reference (factory set)

**RGB/YRGB Selection.** The 1750-Series is factory-set to accept a 3-step RGB parade staircase signal. A 4-step YRGB parade staircase signal may be used by changing the plug jumper for J685 on the Horizontal board (A4). The selections are:

- P685 Pins 2-3 RGB (factory set)  
Pins 1-2 YRGB

**Field Rate Selection.** The 1750-Series is designed to operate with several scanning systems (B, I, M, etc.). The 1750 (which is system M) is factory set to the 60 Hz position. The 1751 is factory set for a 50 Hz field rate. J780 on the Horizontal board (A4) changes the field rate. The selections are:

- P780 Pins 1-2 50 Hz (1751 factory set)  
Pins 2-3 60 Hz (1750 factory set)

**Center Dot Blanking.** The vector display center dot (when chrominance is nearly zero) is blanked to reduce the possibility of burning the crt phosphor. There may be cases where that area of the signal is of interest and the plug jumper for J475 on the Demodulator board (A5) can be used to disable the Center Dot Blanking. The selections are:

- P475 Pins 1-2 Blanked (factory set)  
Pins 2-3 Unblanked

**V-Axis Switching.** P532 on the Demodulator board (A5) selects the V-Axis Switcher Preset. In the PAL (P) position the Preset is from the R-Y phase. In the NTSC (N) position, Preset is grounded.

- P532 Pins 1-2 Switcher Active (1751 factory set)  
Pins 3-4 Switcher Disabled (1750 factory set)

**Burst Sampling.** P534 on the Demodulator board (A5) is used to select whether color burst is sampled every line (which is normal for NTSC (N)), or every other line (which is normal for PAL (P)).

- P534 Pins 1-2 Burst sampled every other line (1751 factory set)  
Pins 3-4 Burst sampled every line (1750 factory set)

**Remote Enable.** J508 on the Interface and HV board (A1) selects whether the Remote Control is activated by a TTL high or low. The selections are:

- P508 Pins 1-2 TTL Low (factory set)  
Pins 3-4 TTL High

**Remote Sync Polarity.** J351 on the SCH Logic board A9 selects the edge for Remote Sync. Selections are:

- P351 Pins 1-2 Syncs on positive-going edge (factory set)  
Pins 2-3 Syncs on negative-going edge.

### Altering Line Selector Operation (internally)

Switch S305, a dual-inline-package (DIP), has five segments that provide part of the line select word to U609. See Fig. 3-5. Normally these segments are all set to the open position, which causes the front-panel LINE SELECTOR to start with line 8 (NTSC) or line 6 (PAL) of the selected field and count up 16 lines. Closing switch segments changes the 16 lines the LINE SELECTOR operates on. Table 3-2 (Remote Line and Field Selection) can be used to determine

what occurs when switch segments are closed. Segment 1 of the switch is the LSB and is equivalent to Remote Line Select Bit 8. S205 is in parallel with the five-line select bits on the remote plug. A switch segment should be open if Remote plug control of line select is desired.

- L = Closed  
H = Open

## MECHANICAL INSTALLATION

### Rackmounting

The optional metal cabinets for the 1750-Series provide the proper electrical environment for the instrument, minimizes handling damage, and reduces dust collection within the instrument. Four 0.156-inch diameter holes in the bottom of the cabinet depressions provide a means for mounting the instrument solidly to a surface, such as a metal shelf in a cabinet rack or console.

With the optional rack adapter accessory, the instrument may be mounted in a standard 19-inch rack side-by-side with another 1750-Series or other half-rack-sized instrument, such as the TEKTRONIX 528A Waveform Monitor or 1420-Series Vectorscope. The adapter includes two attached cabinets that are equipped for rackmounting. If only one instrument is mounted in the rack adapter, a blank panel assembly is available that inserts into the empty cabinet. Fig. 3-6 shows details of the rack installation.

The rack adapter and blank panel are available through your local Tektronix field office or representative. See the listing at the end of this section for Tektronix part numbers.

### Cooling

The 1750-Series is cooled by convection airflow through the instrument. For proper air circulation, a minimum of 44.5 mm (1-3/4 inch) should be maintained above and below the instrument.

**Custom Installations.** All installations must provide the same or equivalent ventilation and mechanical protection, to that of the cabinetized instrument. In addition, top openings should not exceed 4 mm (0.15 inch) in diameter. Other openings should not exceed 12 mm (0.45 inch) in diameter, provided the circuits are at least 20 mm (0.6 inch) from the surface of the enclosure. All conductive parts must be connected to ground or the frame of the 1750-Series.

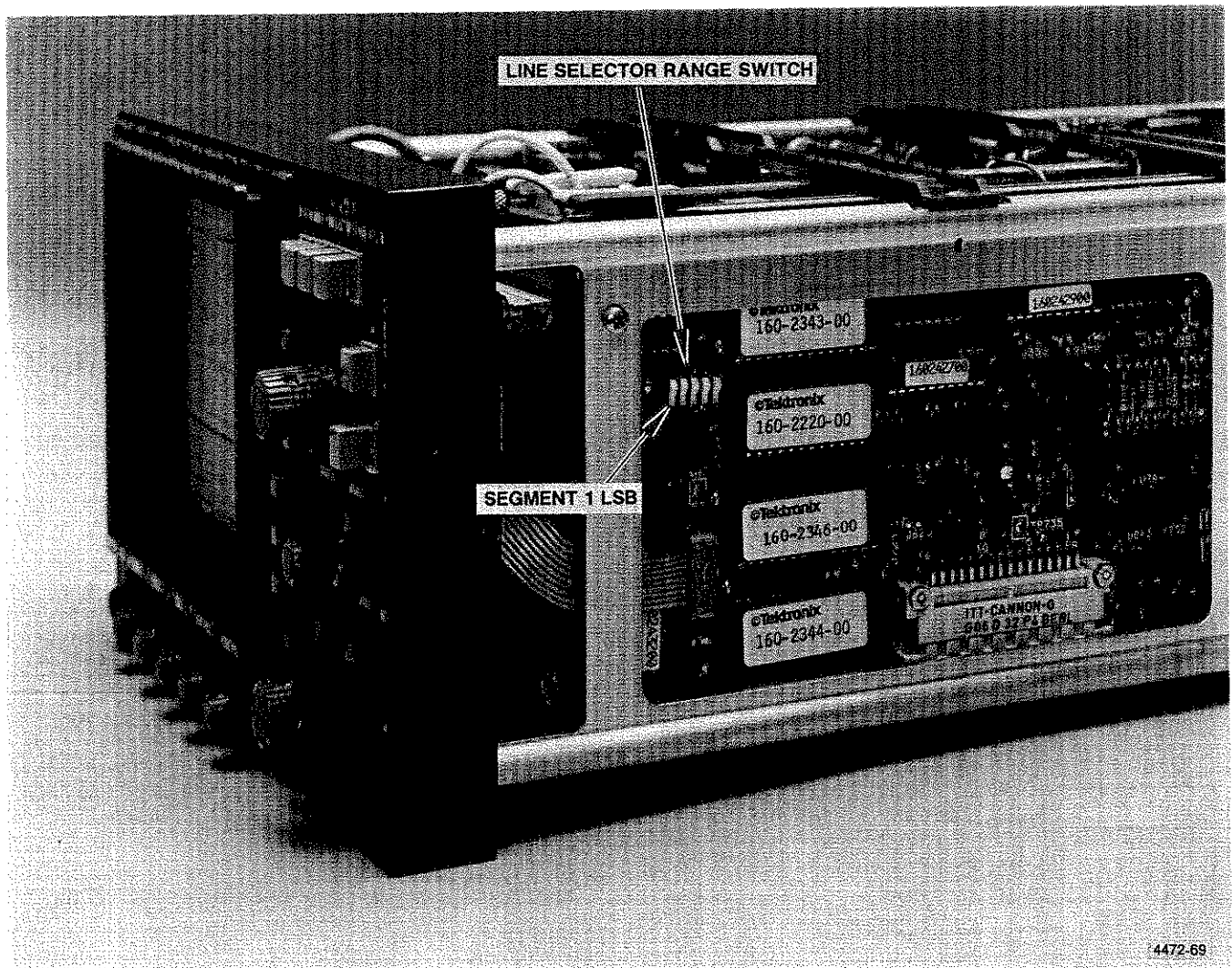

Fig. 3-5. Location of the Line Selector Range switch. (A9-S305).

### Tektronix Part Numbers

Optional Installation Accessories:

Description	Tektronix Part Number
Carrying Case	020-1241-00
Metal Cabinet (without feet and handle)	
Metal Cabinet (with feet and handle)	
Rack Adapter	016-0115-02
Blank Panel Assembly	016-0116-00

These items can be ordered through your local Tektronix field office or representative.

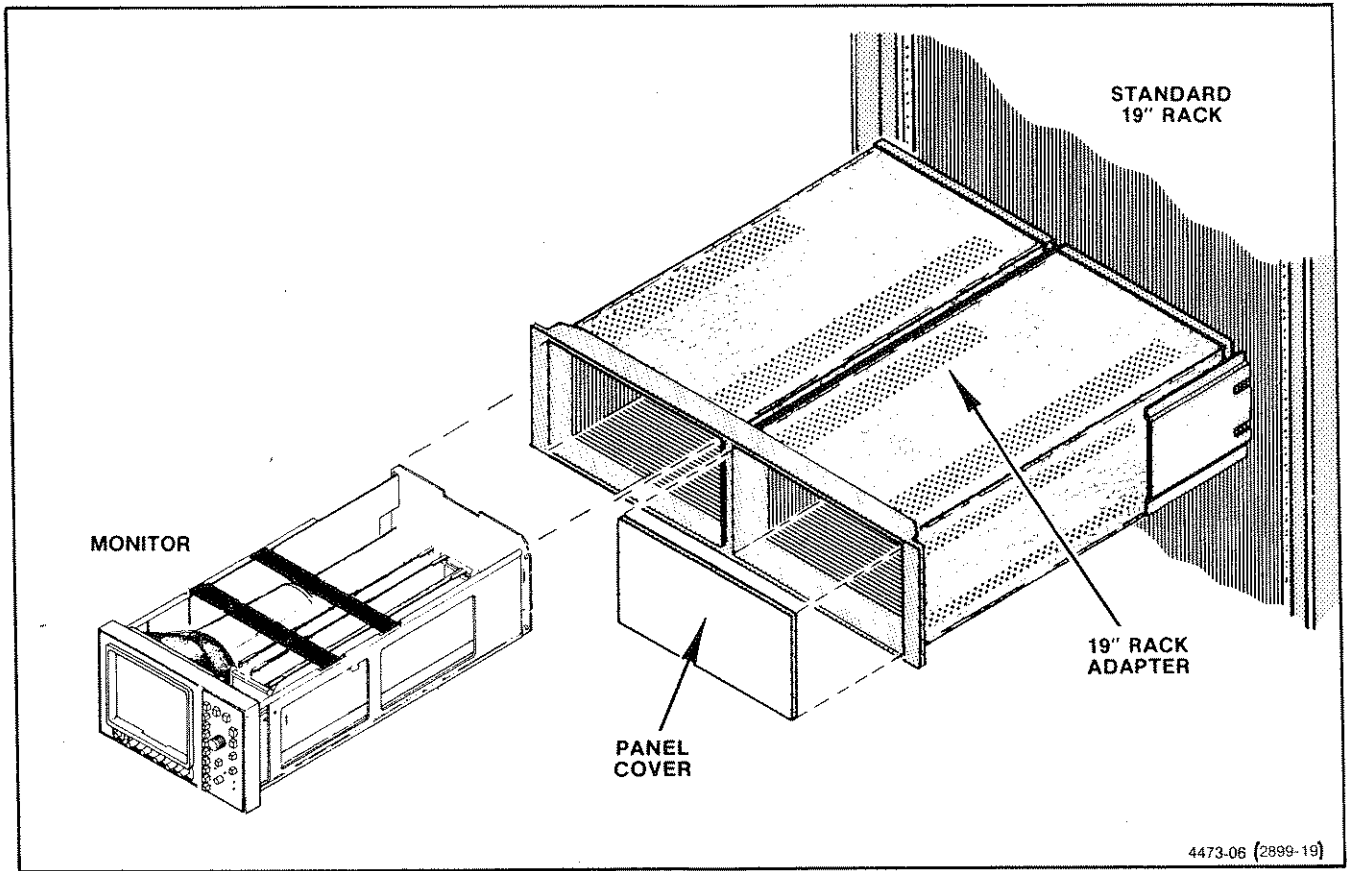

Fig. 3-6. Installation of the 1750-Series in the side-by-side rack cabinet assembly.

# THEORY OF OPERATION

## BLOCK DESCRIPTION

The 1750-Series Waveform/Vector monitors provide cathode ray tube (crt) displays of the video signal in one of four basic modes; the Waveform Mode, the Vector Mode, the R-Y Mode (V-Axis for 1751), and SCH Mode.

The Waveform Mode plots the video signal amplitude with respect to time. The Vector Mode gives an x-y ampli-

tude plot of the B-Y (U-Axis in PAL) and R-Y (V-Axis in PAL) chrominance components of the color video signal. The resulting vector display represents the phase and amplitude of the chrominance components. The R-Y (V-Axis) Mode plots demodulated R-Y chrominance components versus time. SCH Mode creates a special vector display which indicates the monitored signal's subcarrier-to-horizontal phase relationship. Fig. 4-1 shows a simplified block diagram of the instrument.

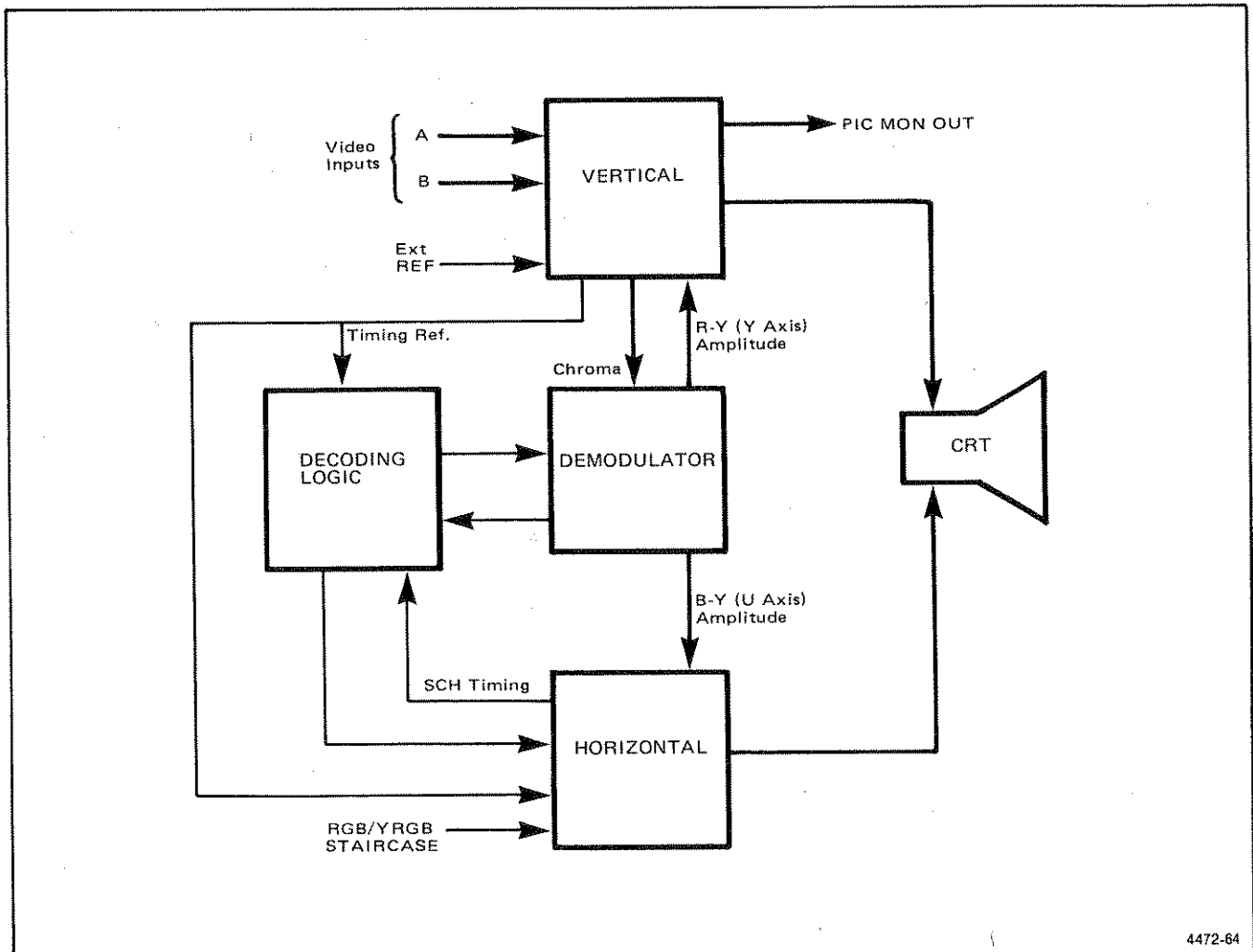

Fig. 4-1. Simplified Block Diagram of the 1750-Series.



## Theory of Operation—1750-Series

In the Waveform Mode, the Vertical block processes the video signal and drives the vertical cathode ray tube (crt) plates. The Horizontal block receives timing signals from the SCH Logic board and generates the appropriate sweep timing and drives the horizontal crt plates.

In the Vector Mode, the Vertical block processes the video signal and feeds the chrominance portion of the signal to the Demodulator block. The Horizontal block provides timing to the Demodulator, and the Demodulator block decodes the chrominance signal. The B—Y (U) signal drives the Horizontal block where it is amplified and, in turn, drives the horizontal crt plates. The R—Y (V) signal output from the Demodulator drives the Vertical block and, in turn, the vertical crt plates.

In the R—Y (V-Axis) Mode, the Vertical block is driven as in the Vector Mode and the Horizontal block operates as in the Waveform Mode. This provides a display of the R—Y (V) chrominance components in the vertical axis and the selected sweep speed along the horizontal axis.

The Front-Panel block (not shown in Fig. 4-1) provides most of the switching and variable controls used with the instrument. The Remote block allows remote control of all of the switching and has inputs for RGB or YRGB camera parade display timing signals.

The CRT Control block provides horizontal and vertical position and calibration controls, provides focus and intensity controls for the crt, and provides control of the graticule scale illumination.

The HV Power Supply block provides the crt high voltage and includes the remaining crt display controls.

The LV Power Supply provides the low voltage sources for the instrument.

## DETAILED CIRCUIT DESCRIPTION

### VERTICAL BOARD (A3)

The Vertical board, when displaying an external signal, receives inputs from the rear panel, processes the signal in the selected manner, and drives the crt vertical deflection plates. The signal source may be either of two loop-thru video inputs (CH-A or CH-B), or the internally-generated calibrator square wave. The display consists of the composite video waveform in the Waveform Mode, the demodulated R—Y (V-Axis) chrominance in the R—Y (V-Axis) and Vector Modes, or a vector signal output from the SCH Logic board and processed by the Demodulator board in the SCH Mode.

The Vertical board controls the signal gain and uses one of three filter frequency response selections for signal display. A VARIABLE GAIN control and X5 GAIN push button can be used to set the gain of the signals.

The FLAT response is used to display the full video bandwidth. IRE response (LUM in PAL instruments) is a low-pass filter that enables the luminance portion of the signal to be displayed without the chrominance. The CHROMA Filter is a band-pass filter which passes only the chrominance por-

tion of the composite signal. The Waveform display (WFM) can be clamped by a slow dc restorer.

The selected signal (Channel A, Channel B, or calibration) is buffered by an input amplifier and is then present at the PIX MON OUT jack on the rear panel. This signal is not affected by the input filters.

The Vertical board also buffers the EXTERNAL REFERENCE signal which can be selected as a synchronization source over the Internal Reference, which follows the input A or B selection. EXTERNAL REFERENCE is taken from a rear-panel loop-thru connector.

### VIDEO INPUT

#### Inputs

The Input block buffers the signals from the loop-thru inputs and selects the CH-A, CH-B, or Calibrator signal to be passed to the vertical amplifier. The EXT REF-loop-thru input is fed to the Horizontal board (A4) after buffering.

The CH-B amplifier is shown at the top of the schematic diagram. The stage includes input coupling, input frequency compensation, a source follower buffer with current source, and an analog switch. The input coupling (either ac or dc) is selected by the position of the jumper on J403. The CH-B Response adjustment, C320, compensates the input response.

The buffer consists of FET source follower Q413 and an FET current source Q412. The two transistors are matched so there is minimum offset voltage across Q413. The final element in the stage is a single-pole-single-throw hybrid analog switch, U426, which is closed by a TTL high signal applied to pin 5.

The CH-A amplifier is similar to the CH-B amplifier except that the CH-A stage has additional adjustments for gain, offset, and phase to match the CH-B stage.

The outputs of the CH-A, CH-B, and Calibrator switches are connected, but only one is enabled at a time by a signal from the switching logic. The output of the selected switch feeds video amplifier U336 in the following stage and provides the Internal Reference signal to the Horizontal board (A4).

The EXT REF input feeds an FET input buffer similar to those which isolate the Channel A and Channel B inputs. The External Phase adjustment, C709, matches the EXT REF channel phase with CH-B and CH-A. The buffer feeds the Horizontal board (A4).

### Calibrator

The Calibrator provides a stable 1-V displayed amplitude and 10  $\mu$ s/cycle (100 kHz) time reference for the instrument. The circuit consists of a 1-MHz crystal oscillator, a decade divider, and an amplifier.

A signal from the Switching Logic block turns on the oscillator when the 1750 is in Waveform Mode and CALibrate is selected (the Calibration signal is useless in any other mode). Decade counter U513 divides the 1-MHz square wave down to 100 kHz. Q320 drives amplifier U319 at the 100-kHz rate. The amplifier output is determined by its gain resistors and the Vertical board (A3) +12 V supply. The Calibrator is adjusted to exactly 1 V p-p on the display by the +12 V Cal Amplitude adjustment, R532 on A3, shown on diagram 2.

### Line Select Bright-up

When digital line select are both enabled from the front panel, the signal STROBE from the SCH Logic board goes

low during the active portion of the selected vertical interval line. This causes Q643 to conduct for the duration of the line and output current to the PIX MON OUT jack. This effectively raises the luminance level of the signal, thus brightening this line when viewed on a picture monitor.

### Switching Logic

The Switching Logic controls the selection of inputs, display modes, and filters. This circuit receives inputs from the Front-Panel board (A8). If the CAL INput is selected, the IRE Filter (1750) or the LUM Filter (1751) is automatically selected and the DC RESTorer is disabled. The CAL INput can only be enabled when Waveform (WFM) Mode is selected, otherwise it has no effect. If the Vector, SCH, or R—Y (1750) or V-Axis (1751) Modes (Demodulator displays) are chosen, the CHROMA Filter is automatically selected.

### Filters

The Filters determine the frequency response of the instrument. They enable the operator to condition the video input and observe different signal components of the composite signal. The stage consists of an amplifier and three FILTER selections; FLAT, IRE (1750) or LUM (1751), and CHROMA. The amplifier also provides the PIX MON OUT signal.

The amplifier, U336, is a non-inverting, hybrid, operational amplifier. The gain is determined by R136 and R235. The low impedance output of U336 drives the filter circuits and is used with a 75- $\Omega$  output resistor, R340, to drive the PIX MON OUT connector on the rear panel.

The video amplifier output goes to each of the filter circuits. The Switching Logic block enables the filter selected by the front-panel FILTERS switches. Each of the filter circuits has a current output through its saturating transistor switch. The output goes to the Variable Gain Amplifier, U468.

The FLAT selection provides a flat frequency response. The video signal goes through Q655 with no filtering.

The IRE (1750) or LUM (1751) FILTER selection is a low-pass filter used to remove the chrominance subcarrier from the displayed signal. The gain of the low-pass filter is matched to the flat display by R560. The response for this filter is slightly different for NTSC and PAL instruments.

The CHROMA Filter selection is a bandpass filter centered on the chrominance subcarrier. The type of filter used is called a Lerner filter. It has arithmetic amplitude symmetry and linear phase response across its bandwidth. This re-

## Theory of Operation—1750-Series

sponse gives excellent bandpass shaping for evaluation of the chrominance signal.

### Variable Gain Amp

The Variable Gain Amplifier is controlled by front-panel VAR GAIN and WAVEFORM VERT CAL controls.

The current from the response filters is converted to a voltage by an amplifier, Q759, Q856, and Q761. The feedback gain is determined by R859.

Amplifier U468 gain is controlled by the voltage at pin 7. A voltage that is varied between ground and 1/10th the positive supply voltage sets the gain between 0 and 1, respectively. The supply voltage for the VAR GAIN control is set by the front-panel WAVEFORM VERT CAL control and the Gain 1<sup>-</sup> adjustment, R664. After the front-panel WAVEFORM VERT CAL control is centered, R664 adjusts the gain from the signal input to TP379 at the output of the DC-Restored Amplifier. The Variable Balance control, R562, is adjusted for no dc movement of the output as the VARIABLE GAIN control is rotated by adjusting the dc bias on the non-inverting input of U468.

The output of U468 drives the Chroma Amplifier on this diagram and the DC-Restored Amplifier on diagram 2.

### Chroma Amp

The Chroma Amplifier buffers and sets the gain of the chroma signal before it is sent to the Demodulator board (A5). The circuit input is to Q566, and the output is at TP662. The amplifier gain is determined by resistors R670 and R871. When one of the Demodulator modes is selected, the CHROMA Filter is also automatically selected.

The chroma X5 GAIN function is provided by this amplifier in the Demodulator modes. When X5 GAIN is not selected, part of the current from Q566 is shunted away from the signal path by R569 and Q674. When X5 GAIN is selected, Q674 is turned off. The signal current, after passing through Q673, is added to the current summing junction at the base of Q875.

## Vertical Output

### DC Restorer

The DC Restorer clamps the video signal to remove low-frequency fluctuations as it goes through the DC-Restored Amplifier. The circuit uses feedback dc restoration and consists of a sample-and-hold amplifier and an active filter.

Sample-and-hold amplifier U786 samples the DC-Restored Amplifier output signal at the collector of Q479 after the signal is low-pass filtered. Sampling is enabled by the front-panel DC RESTorer push button and is automatically disabled by selection of the CALibrator INput. The Clamp Pulse sets the sample time to occur during back porch (factory-set) or sync tip as determined by the position of jumper J477 on the Reference Timing board (A3).

The restorer response is determined by active low-pass filter U780. The filter attenuates level changes that occur at the power mains frequency and above. Thus, the clamp level changes only with low frequency changes. This allows the DC-Restored Amplifier to pass signals at the mains frequency and above, but clamp any low-frequency fluctuations.

The output of the low-pass filter feeds the clamp point at the input of the DC-Restored Amplifier.

### DC-Restored Amplifier

The DC-Restored Amplifier is an operational amplifier that is enabled during the Waveform Mode to pass the video signal. If the DC Restorer is enabled, the output of this amplifier is clamped to eliminate low-frequency variations. The output of the amplifier feeds the Waveform Mode inputs to the Vertical Output Switch.

### Vertical Output Switch

The Vertical Output Switch selects the input and the gain for vertical crt deflection. The circuit also converts the single-ended inputs to differential outputs to drive the Vertical Output Amplifier. The circuit selects from two inputs; the DC-Restored Amplifier output or the R-Y output from the Demodulator board (A5). The DC-Restored Amplifier is selected for the Waveform Mode, the R-Y Demodulator output is selected for the Vector, SCH, and R-Y (1750) or V-Axis (1751) Modes.

The circuit consists of three differential amplifiers and three switch transistors. The three differential amplifiers can be individually enabled by providing bias current to their emitters. The bias current sources are Q393, Q394, and Q493. In addition, the Bias adjustment, R250, controls the amplitude of the current from these current sources by setting the quiescent voltage of the Vertical Output Amplifier.

The current sources are enabled according to the front-panel switch selections for mode and gain.

In the Waveform Mode, Q394 supplies current to Q483 and Q488. Q493 is off in this case, forcing current from

Q494 to pass through Q394. Adjustments FR3 (C288) and FR4 (R182) are for frequency response compensation. When X5 GAIN is selected, Q393 supplies current to Q481 and Q389.

In the Vector, SCH, and R—Y (1750) or V-Axis (1751) Modes, Q493 supplies current to Q485 and Q487.

The Gain 2 adjustment, R176, across the differential output of the stage, is adjusted for crt deflection sensitivity differences.

A voltage limiter stage, Q283 and Q284, prevents the Vertical Output Amplifier from saturating. If the voltage at either emitter falls below the base voltage, the voltage is limited and the additional current for this node is shunted from the opposite side of the differential output.

The vertical Mag Registration adjustment, R274, is used to adjust the amplifier dc offset so the displayed signal is magnified around the graticule base line (0 IRE or 0 V) when X5 GAIN is selected.

### Vertical Output Amplifier

The Vertical Output Amplifier amplifies the signal selected by the Vertical Output Switch and drives the crt vertical deflection plates. The amplifier is a combination of an operational amplifier and a grounded base amplifier. The circuit is symmetrical, with the center of R361 equivalent to ac ground.

Q255 and Q248 form a unity-gain, non-inverting amplifier with its output at the collector of Q248. This amplifier has a very high input impedance, resulting in low power dissipation in Q255. Therefore, the base-to-emitter voltage of Q255 does not change due to power changes at signal extremes. Also, the low power dissipation means that the circuit does not load the input.

Because the current in Q255 is nearly constant, most of the changes in current in R362, R360, and R361 flow in Q248 and through Q143 to the output. Since the base current of Q248 is summed with its collector current at the emitter of Q255, gain nonlinearity is avoided. The inductor, LR143, and the crt deflection plate capacitance critically damp the signal.

### Power Supplies

Power Supplies for the Vertical board (A3) are provided by on-board monolithic regulators. The +12 Volt supply is adjusted by R532, and is measured at TP139. This supply

adjustment is used to set the amplitude of the calibrator signal. The -12 Volt supply is adjusted by R535, and is measured at TP233. The +5 Volt supply is regulated on the Low Voltage Supply board (A6), and is measured at TP420. Each of the supplies is current limited by its regulator.

## HORIZONTAL BOARD (A4)

The Horizontal board (A4) detects the 50% point of the leading edge of horizontal sync, contains phase detectors for sync phase lock loops, generates the sweep ramps for WFM and R—Y (V-Axis) displays, and amplifies the sweep and RGB signals to drive the crt horizontal deflection plates.

Timing for sweep generation is derived either from the internal video signal (A or B as selected from the front panel or remote control) or from an external reference. Signals for the SCH display are generated to identify the 50% amplitude point of the leading edge of sync from both the internal video signal (A or B) and the selected signal (either internal or external) sync reference.

The sweep generator circuits produce sweep ramp signals synchronized to the line or field rate. Each sweep can be magnified and the offscreen portion blanked to increase contrast. When the RGB parade display is enabled, the sweep is shortened and is offset by the RGB Staircase input signal to produce three short ramps that are displayed as one normal sized sweep. The board is also able to produce the YRGB display.

The Horizontal Output Amplifier drives the crt horizontal deflection plates. In the Waveform and R—Y (1750) or V-Axis (1751) Modes, the sweep ramp is amplified. In the Vector or SCH Modes, the B—Y Demodulator signal is amplified.

## Sync Clamp

### Sync Reference Switching

The Sync Reference Switching block selects either the internal reference (sweep timing based on the selected A or B input) or an external source (from the rear-panel EXT REF loop-thru).

Both internal and external references are routed from the Vertical board (A3) and fed to the Horizontal board for sweep reference. U620 and U624 are hybrid analog switches which pass the timing reference signal (internal or external, respectively) when a TTL high is present at pin 5. Reference selection is dictated by the EXT signal, which is asserted low when EXT REF is selected from the front panel, enabling U624.

## Theory of Operation—1750-Series

The output from U620 and U624 (selected internal or external reference) is routed to the Demodulator board 5 where the burst in the selected reference is used for subcarrier regeneration and axis demodulation. It is also routed to a sync stripper on the SCH Logic board, diagram 8, for sweep synchronization.

### SCH Locate (1 and 2)

These blocks, with almost identical configuration, identify the 50% point of the leading edge of horizontal sync in the internal reference (SCH Locate 1) and the selected reference (SCH Locate 2) between internal and EXT REF. The SCH Locate 1 block will be described, with any differences between it and the SCH Locate 2 block identified in the description.

The internal reference sync signal (front panel-selected internal or EXT REFERENCE for SCH Locate 2) is buffered by Q805 and input to sync stripping circuit U400. This IC performs two functions; it acts as an automatic gain control (AGC) to create a reference for 50% sync point location (output pin 13), and it separates horizontal and vertical sync from the composite video signal. This "stripped" sync is then output (at pin 5) at TTL levels (active low) for intra-line decoding by a state machine on the SCH Logic board 7.

The pin 13 output of U400 is inverted and amplified so the sync level is normalized. This signal is again inverted by Q615 for input to hybrid IC U217, a differential amplifier with both voltage and current outputs. The differential voltage outputs (pins 14 and 19) are sampled by U200 and U300 (sample-and-hold circuits). Their output is combined with feed-forward from U400, and is input to U210A and B, which provide a feedback to control the 50% sync edge detection levels output by U217.

The current outputs from U217 (pins 16 and 18) are enabled by current input to pin 17. This current is provided by U119, a gated current source which provides a differential current output whenever pin 7 is asserted with a TTL high (signal). PDW1 (phase detector window 1) is a signal from the SCH Logic board 7, and is asserted to provide a window around the 50% point of the leading edge of horizontal sync.

The differential current output from U217 is fed to both sides of current mirror U619. This device causes a current to flow into its output, which is the same amplitude as the current into its input. The current node at the output of U619 also has a current source from U412. This current, when converted to a voltage on the SCH Logic board 7, controls a VCO (Voltage-Controlled Oscillator) and determines the position of the SCH vector on the SCH display.

## Power Supplies

Two monolithic voltage regulators, U748 and U752, provide the +12 and -12 Volt power for the Horizontal board (including both 3 and 4). These voltages are adjustable with R445 and R650, respectively. The 5 Volt supply is not regulated on the Horizontal board, and is not adjustable.

## Sweep Generator and Horizontal Output

### Ramp and Mag Switching

Inputs from the front panel, a field rate strobe, and a line enabling RGB display feed PAL U670 which acts as a decoder to determine maximum sweep ramp amplitude and duration. U670 outputs feed switching circuitry in the Sweep Generator and Mag Amp. Q685 acts as a switch enabled directly from the active low RGB ENable line.

### Sweep Generators

The Sweep Generators block includes two independent sweep circuits, one each for line and field rates. Each sweep is independently triggered and enabled by trigger signals from the SCH Logic board (A9). The slope of the sweeps can be adjusted from the front panel with the SWEEP CAL screwdriver adjustment just under the front of the crt. During calibration of the instrument this control is centered. Internal adjustments are made for timing calibration.

For one line or one field, Q775 is turned on supplying twice the voltage to R882 and R880, the timing resistors. Q775 is also turned on for the parade display. Q687 is used as a sweep attenuator when parade display is active. Jumper J685 is used to select a sweep 1/3 or 1/4 of normal length. Jumper J780 is used to select the ramp slope for 50- or 60-Hz field rates.

The two sweeps are combined at the input to the Horizontal Mag Amplifier, and to circuitry which switches between ramp drive (for WFM or R-Y Modes) or B-Y (from demodulator, for the SCH and Vector Modes). Switching transistors Q181 and Q180 and diodes supply switching current to diodes CR276 or CR275 to enable either the ramp generator output or the input from the Demodulator board (signal gain determined by R845).

### RGB/YRGB Staircase Input

The RGB/YRGB Staircase Input at the REMOTE connector is used to generate a parade display of the video signal components from a camera control unit (CCU). The CCU supplies a staircase signal which changes levels at the

same time that a different component is switched to the CCU output. Video gamma and contour can be adjusted while viewing the R, G, and B components separately.

The enabling signal at U670 (pin 2) and the base of Q685 selects RGB, attenuates the sweep, and forces the sweep to one line or one field. Compensation capacitor C373 is used to adjust the staircase transitions of the amplifier output at TP580 for best rise time without overshoot. RGB Center adjustment R471 compensates for the dc offset of the staircase signal.

### Horizontal Mag Amp

The Horizontal Mag Amplifier (including Q489 and Q290) controls the gain of the sweep signals. The junction of Q489 and R596 is the summing junction for signals produced by the sweep generator, RGB input, and demodulator input. Feedback current through R394 and R596 is shunted by Q496, Q497, and Q395 to provide magnified gain. The 10X magnification in 2H MAG display is set with R297. Turning on Q497 provides additional current shunting for approximately 20X gain in Field MAG displays. All three transistors (Q496, Q497, and Q395) are turned on for 1H MAG, with calibration provided by adjusting R296. A reference voltage for biasing the Mag Amplifier switching transistors is provided by U695.

Sweep Mag Register R180 is adjusted so that if a centered two-line or two-field sweep is magnified, some portion of the blanking interval will be displayed. Sweep calibration in unmagnified two-field sweep is set with the 10  $\mu$ s/DIV adjustment, R181. The other sweeps depend on the precise tolerances of their parts for their relationship to the two-line sweep.

### Offscreen Blanking

U315A and B sense the output of the Horizontal Mag Amplifier, and if the output transistor, Q208, is saturated or cutoff, the output of U315 at R443 will go low. This will bring high SWPBLNK, a signal output to the SCH Logic board. If SWP BLANK EN is also high and the instrument is not in Vector Mode, the SCH Logic board will blank the crt during non-waveform time (when the crt spot is off screen), thereby increasing the contrast of the viewed waveform.

### Horizontal Output Amplifier

The Horizontal Output Amplifier drives the horizontal plates of the crt differentially. Differential mode amplifier feedback is returned from the collector of Q158 to the base of Q466. Common mode feedback from both outputs is returned to the emitter of Q466. R363 and C263 compensate the amplifier frequency response. Collector bias current for Q149 and Q163 is provided by Q153 and Q158.

## DEMODULATOR BOARD (A5)

The Demodulator board regenerates subcarrier from the reference burst and demodulates the chrominance component of the color video signal using the regenerated subcarrier as a reference. The signal is demodulated along R—Y and B—Y (V and U for the 1751) axes when the reference burst phase is aligned properly on the Vector Graticule.

The output of the Demodulator may be displayed in Vector, R—Y (1750) or V-Axis (1751) Modes, or the SCH Mode. The Vector Mode uses the R—Y (V) signal to drive the vertical crt plates, and the B—Y (U) signal to drive the horizontal plates. With the burst phase aligned to its graticule marks, the R—Y (V-Axis) Mode displays the demodulated R—Y waveform with the timebase selected by the SWEEP push buttons.

In SCH Mode a regenerated subcarrier signal from the SCH Logic board (phase locked to the 50% point of the leading edge of horizontal sync) is demodulated and displayed vectorally. The color burst is also demodulated and displayed in this manner. The resulting vectoral display then directly shows the phase relationship between the leading edge of sync and regenerated burst.

## Subcarrier Regenerator 5

This diagram contains a group of blocks that act together to form a phase lock loop circuit. These circuits are the Subcarrier Regenerator (Oscillator), Burst Demodulator, Burst Amplifier, and Phase Lock Control blocks.

The Chrominance Input Amplifier, Chrominance Clamp, Center Dot Blanking, and the board Power Supplies are also shown on this diagram.

### Phase Lock Loop Basic Operation

Fig. 4-2 shows a block diagram of the phase lock loop. The Subcarrier Oscillator is a voltage-controlled oscillator (vco) that free runs near the reference subcarrier frequency. The Burst Demodulator is a mixer that detects phase differences between the reference input and the Subcarrier Oscillator during burst time (gated by a signal from the SCH Logic board). The difference output is an error signal proportional to the phase difference detected.

The error signal feeds the Phase Lock Control block. This block is a low-pass loop filter that removes high-

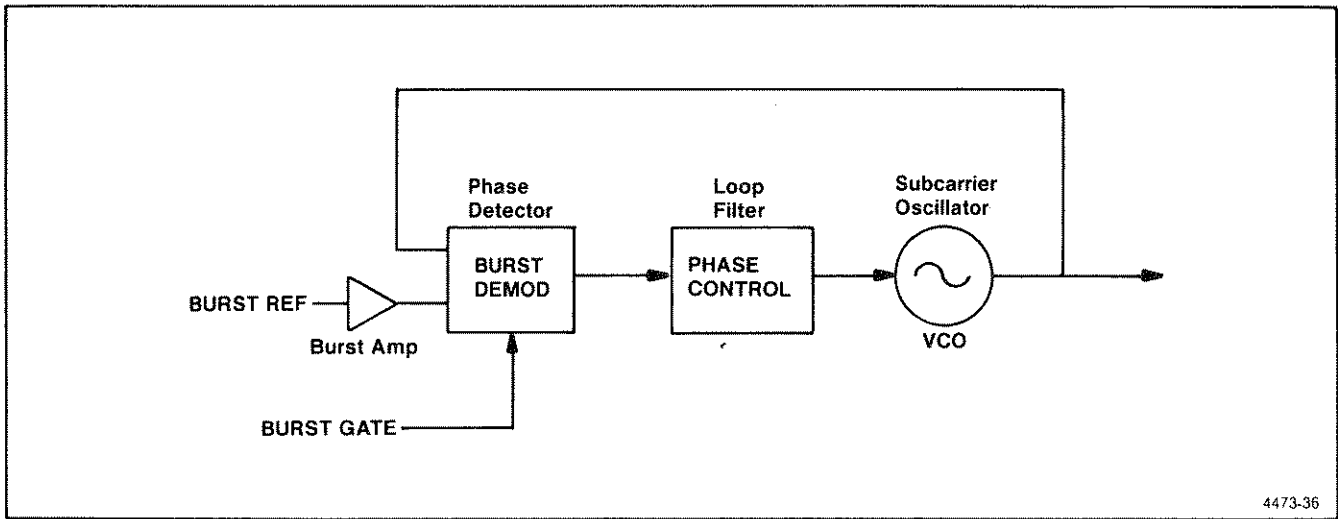

4473-36

Fig. 4-2. Block diagram of the Phase Lock Loop.

frequency ac components in the error signal. The filter has two bandwidths, a wide one for searching for the unlocked signals, and a narrow one for maintaining stable phase lock once the signal has been captured.

The Phase Lock Control loop filter completes the loop by controlling the Subcarrier Oscillator. If the input reference changes, the oscillator will follow. For the 1751, the PAL Phase Lock Control block samples every other burst.

The oscillator is a phase-locked, voltage-controlled, crystal oscillator (vco) with automatic gain control (agc). The basic circuit consists of Q545 and Y745. Fig. 4-3 shows an equivalent circuit. The base of Q545 appears as a negative resistance shunted by the reactance of capacitive divider C546 and C759. This negative resistance compensates for the positive resistance of the crystal circuit and the bias network to maintain oscillation. The magnitude of the negative resistance is controlled by the bias current in Q545.

**Subcarrier Oscillator**

The Subcarrier Oscillator regenerates a continuous subcarrier signal. This circuit is part of a phase lock loop that is referenced to the input color burst. The front-panel PHASE control adjusts the oscillator output phase. The output amplitude is leveled. The Demodulator circuits, shown on diagram 6, use the oscillator output to recover the chrominance information.

The output of Q545 collector drives the front-panel PHASE shifter and the Burst Demodulator. The Burst Demodulator is the part of the phase lock loop that samples the phase relationship between the Subcarrier Oscillator and the reference subcarrier. The PHASE shifter on the Front-Panel assembly, A8, is a device that allows shifting the display phase through a 360° range.

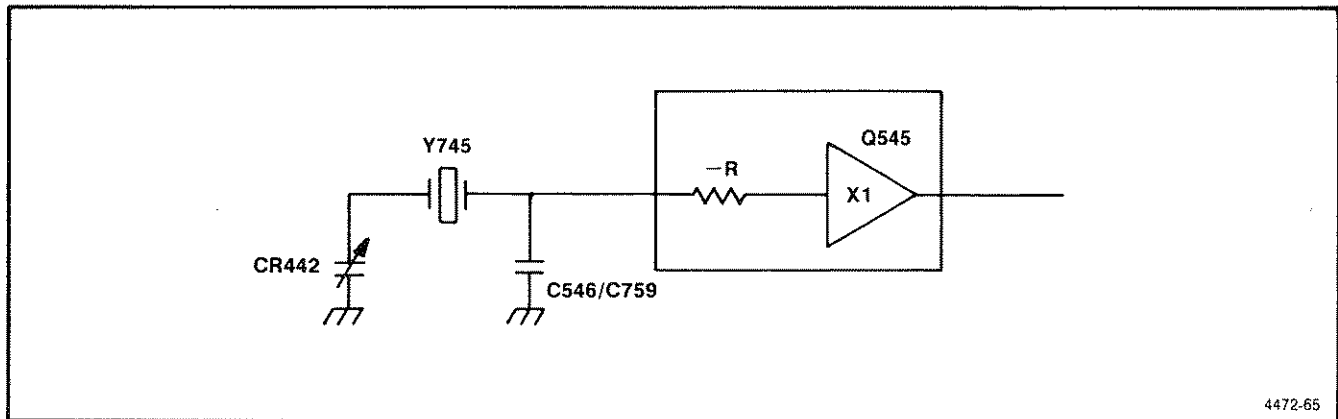

4472-65

Fig. 4-3. Subcarrier Oscillator equivalent circuit.

Subcarrier amplifier Q435 amplifies the goniometer output. This stage drives the Chrominance Demodulators shown on diagram 6, and drives the agc transistor, Q437.

The subcarrier amplitude at the collector of Q435 is rectified by CR335 and stored on C148. The dc level at C148 is used by transistor Q437 to control the bias of Q545 to correct for any fluctuations in amplitude. The bias current for Q545 is inversely proportional to the stored level on C148. If the amplitude rises, Q437 reduces the gain; if the amplitude goes down, the gain increases, thus stabilizing the subcarrier amplitude.

The Phase Lock Control block completes the phase lock loop around the oscillator by feeding an error signal to varactor diode CR442. The diode depletion region widens as it is reverse biased and narrows as it approaches conduction. This causes a capacitance change when the bias changes, thus changing the vco frequency. This compensates for any frequency or phase difference between the Subcarrier Oscillator and the reference burst. Adjustments R170 and R176 set the high and low frequency limits of the oscillator phase lock range.

### Burst Amplifier

The Burst Amplifier, Q571 to Q263, buffers and band limits the reference input and feeds it to the Burst Demodulator. The reference input circuit on the Horizontal board (A4) selects the reference source. Band limiting is provided by L371 and C273.

### Burst Demodulator

The Burst Demodulator detects phase differences between the Subcarrier Oscillator and the input reference signal during burst time. The output is an error signal that is proportional to the phase difference. The error signal is filtered by the Phase Lock Control block and then looped back to the vco.

The Burst Demodulator can be considered as a mixer that functions as a phase detector. It has a reference input, a switching input, and an output. The reference input (burst) mixes with the switching input (subcarrier) and the resulting difference frequencies appear at the output, which in this case is the center tap of transformer T360. The low-pass filter that follows the Burst Demodulator eliminates the high-frequency components of the mixer output. Fig. 4-4 shows a simplified schematic diagram.

Chrominance from the Burst Amplifier is applied to the primary of T360, the reference input. The transformer secondary, the switching input, is switched by Q456 and Q457 so that opposite ends of the windings are alternately grounded at a subcarrier rate. The transformer center tap is the phase detector output. A low-pass filter removes the switching components and stores the error level until the next burst sample.

The Subcarrier Oscillator signal is buffered by Q452 and fed to the switch drivers, Q556 and Q554. The Burst Gate signal, through Q656, enables the switch drivers during the burst sampling time. During that time, the subcarrier is converted to differential square waves by switch drivers.

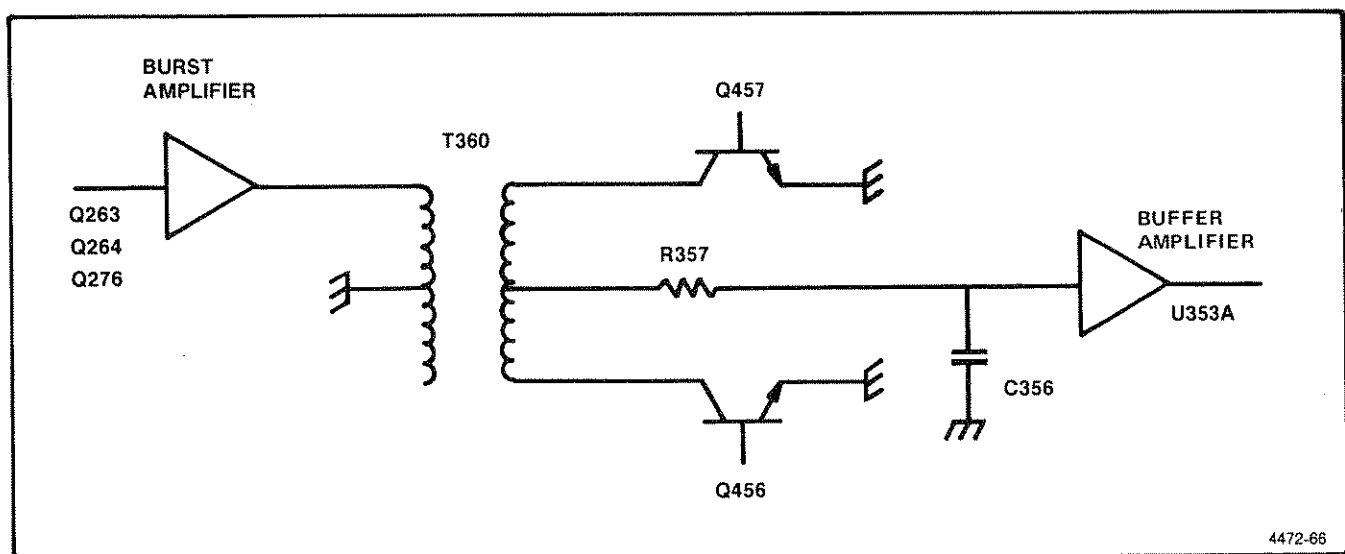

Fig. 4-4. Simplified schematic diagram of the Burst Demodulator.



## Theory of Operation—1750-Series

The square wave output drives the switches, Q456 and Q457, so that each is on for one-half of a subcarrier cycle. These transistors alternately clamp the T360 secondaries to ground. The two secondaries are phased 180° apart so that on alternate subcarrier half-cycles the signal at their junction is shifted 180°. At the same time the secondaries are switched, the burst being sampled also goes through 180° of phase shift. The result at the secondary center tap (phase detector output) is full-wave rectification of the burst.

This synchronous demodulation depends on the relative phase between the two inputs. If the Subcarrier Oscillator has zero crossings at the same time as the burst, a maximum voltage is output. If the subcarrier is delayed by 1/4 cycle, then the output voltage is zero.

The rectified burst is filtered by R357 and C356 and applied to the input of the Phase Lock Control block. The charge on C356 is retained over the entire video line because there is no discharge path for it except during burst time. The Phase Lock Control input, U353A, is high impedance, and the switching transistors, Q456 and Q457, are off except during burst time.

The second T360 primary winding provides reactive shielding for one of the secondary windings.

### Phase Lock Control

The Phase Lock Control circuit takes the output of the Burst Demodulator and controls the phase and frequency of the Subcarrier Oscillator. The circuit is a low-pass filter that sets the loop response. The response is wide when first locking up, and then narrows to maintain stable phase lock.

The input to the Phase Lock Control circuit is the level stored on C356. This voltage is near zero when the oscillator is phase locked; and when unlocked, is a sine wave of the difference frequency, or a level proportional to the phase difference. Amplifier U353A acts as a buffer between the storage capacitor, C356, and the loop response amplifier, U344. In the 1751, the PAL Phase Control block inserts a sample-and-hold circuit, U444, between the buffer and the Loop Response Amplifier. This circuit samples the error voltage on every other line to detect the PAL burst. The Loop Response Amplifier, U344, drives the frequency control input of the Subcarrier Oscillator.

When locked, the loop response is approximately 10 Hz, as determined by R348, R144, C146, C144, and C145. When unlocked, the phase lock loop needs a wide response range to allow a wider difference between the reference input and the Subcarrier Oscillator. The unlocked condition is sensed by U353B. A sine wave appears at TP250 when the

loop is unlocked. A sine wave which has a peak value greater than 100 mV peak is amplified by U353B, rectified by CR150, and stored on C150 to turn on Q347. Q347 shunts R348 with R146, which is a much lower value. This sufficiently increases the loop bandwidth, allowing the loop to capture the free running Subcarrier Oscillator frequency and bring it within the narrow bandwidth limits.

When the oscillator frequency is within the narrow limits, the waveform at TP250 is below the threshold voltage at U353B, pin 6. The output of U353B goes low, turning off Q347, and restoring the narrow bandwidth operation of the phase lock loop.

Two controls are used to adjust the phase lock loop. Balance control, R173, is adjusted to remove offset voltages that cause phase shifts with burst amplitude changes. Jumper J159 forces U344 to its supply limits for calibration of the Subcarrier Oscillator frequency limits.

### PAL Phase Lock Control (1751 Only)

Phase lock of PAL signals in the 1751 is slightly different than for NTSC signals in the 1750. The PAL Phase Lock Control circuit samples burst only once for every two lines of video.

The alternating 90° phase shift of the PAL +V and -V bursts causes transitions in the error signal at the output of U353A. The negative edge of these transitions causes a positive-going edge at the collector of Q253. This saturates Q433 for a short time, generating the +V Phase pulse on the +V lines. This pulse presets U534A and U534B, both shown on diagram 6.

The output of U534B controls sample-and-hold circuit U444. The net effect is that U444 samples only after the negative-going transitions of U353A, thus ignoring every other burst phase. (In the 1751, U444 is installed between the output of U353A and the loop filter and W347 is not installed.)

Q260 inhibits Q433's operation during the Field Trigger pulse. Thus, the operation of the phase lock loop is not disturbed by the alternating phase of the PAL burst or vertical blanking.

PAL phase sampling may be defeated by placing the PAL Sample jumper on J728 (shown on diagram 6) in the N (NTSC) position. The phase lock loop will work with the jumpers in these positions, but with lower performance in the V-Axis Mode.

Burst Present is a TTL signal output to the SCH Logic board, and indicates whether there is burst on the reference video signal from the Horizontal board. For Burst Present to go high both Q662 and Q664 must be turned off. This happens when Burst Gate is low (turning off Q662) and when burst is present in the reference signal Burst (turning off Q664 during Burst Gate).

### Chroma Source Switches

U597 and U797 are hybrid analog switches which select either the selected chrominance signal (from the Vertical board) or a regenerated subcarrier signal CW1 (phase locked to the 50% point of the leading edge of horizontal sync) from the SCH Logic board.

CW1, the output from U597 when CW1 Select is high, is selected when the SCH display is active. Chroma, the output from U797 when Chroma Sel is high, is selected when Vector or R—Y Modes are selected. The outputs from both switches are summed at the input to the Chrominance Input Amplifier, R695.

### Chroma Amplifier

The Chrominance Input Amplifier buffers the chrominance signal following the Chroma Source Switch for use by the Center Dot Blanking circuit and the Chroma Demodulators shown on diagram 6.

The Inverting Amplifier, which is composed of Q695, Q596, and Q595, is disconnected from the Demodulator by the Chroma Clamp circuit when Chroma Gate or WFM is low.

### Chrominance Clamp

The Chrominance Clamp circuit turns off the chrominance signal to the Demodulators. The clamp's output at the drains of Q494 and Q492 is turned on by the Chroma Gate. The output clamps the demodulator position the Vector signal during the time while the Chroma Clamp is on. In the Waveform Mode, the clamp is on continuously to avoid any possible interference with the Waveform display.

### Center Dot Blanking

The Center Dot Blanking circuit blanks the crt if the output of the Chrominance Input Amp is nearly 0 V (very low chrominance). The crt is blanked to lower the brightness of the center dot. This function is only active during Vector and SCH displays.

The signal from the Chroma Amplifier feeds limiter Q683 and Q681. The chroma signal is envelope detected by Q383 and C377. The blanking signal from Schmitt level detector U477 is NANDed with the vector clamp unblanking signal in Vector Mode so that the center dot will be visible, but not bright enough to burn the crt when no signal is present.

Blanking is enabled in the Vector Mode by U674. In other modes blanking control is transferred to the Horizontal board (A4).

Center Dot blanking can be disabled by moving the jumper on J475 to pins 2-3. This allows viewing very low amplitude chrominance signals.

### Power Supplies

Power Supplies for the circuit board are provided by monolithic regulators. The +12 Volt supply is adjusted by R186, and is measured at TP176. The -12 Volt supply is adjusted by R192, and is measured at TP180. The +5 Volt supply is not adjustable, and is measured at TP175. Each regulator limits the current for its supply.

## Demodulator

### V-Axis Switcher

The V-Axis Switcher inverts the V-Axis Demodulator carrier input on alternate lines. In the 1750, V-Axis Switching is normally disabled by J532, but may be enabled for the Quad Phase adjustment during calibration. In the 1751, V-Axis Switching is normally enabled, but is only active when the front-panel switch +V/PAL is in the +V position.

V-Axis Switching provides Vector and V-Axis Mode displays of the PAL signal that overlays the -V lines on the +V lines. The resulting display appears as though only the +V signal is displayed, similar to an NTSC display. The display is useful for evaluating relative differences between the +V and -V lines. This same operation occurs when the signal is decoded in a PAL television receiver.

When the front-panel switch is in the +V position, CR741 is shut off and allows the Vector Clamp signal, through Q542, to clock D flip-flop U534A each line. The +V Phase pulse, from the PAL Phase Lock Control circuit shown on diagram 5, presets the flip-flop on the +V lines to synchronize the V-Axis Demodulator.

## Theory of Operation—1750-Series

The flip-flop drives Q429 and Q432. When on, Q429 shunts the  $-V$  Demodulator carrier input, allowing the  $V$ -Axis subcarrier to drive the  $+V$  input. Alternately, when Q432 is on, the signal goes to the  $-V$  input. Thus, the Demodulator output produces a  $180^\circ$  phase shift.

The jumper on J532 determines whether  $V$ -Axis Switching is enabled or disabled. In the N (NTSC) position (factory-set for the 1750), the preset on U534A is grounded. Switching is inhibited, and Q430 shunts the  $-V$  input. In the P (PAL) position (factory-set for the 1751), the  $+V$  Phase pulse presets U534A.

### Chroma Demodulators

The Chrominance Demodulators are synchronous demodulators driven by the Subcarrier Oscillator and the Chrominance Input Amplifier. The output from these demodulators, at pin 6, is a voltage proportional to the difference in phase between the two signals input at pins 7&8 and pins 1&4.

The Demodulator gains are set by R115 ( $R-Y$  or  $V$ ) and R518 ( $B-Y$  or  $U$ ). The demodulator bias is controlled by the position clamp circuits. The Subcarrier Oscillator drives the  $B-Y$  ( $U$ ) Demodulator directly. The subcarrier is shifted  $90^\circ$  by the quad phase coil, L132, to drive the  $R-Y$  ( $V$ ) Demodulator. The  $V$ -Axis Switching circuit may also alternate the phase of the subcarrier received by the  $R-Y$  ( $V$ ) Demodulator (as explained in the  $V$ -Axis Switching discussion).

### Demodulator Output Amplifiers

The Demodulator Output Amplifiers filter the Demodulator signals and drive the crt output amplifiers, which are located on the Vertical (A3) and Horizontal (A4) boards. The two amplifiers on this board are the  $R-Y$  ( $V$ ) and  $B-Y$  ( $U$ ). Since the two amplifiers are nearly the same, only the  $R-Y$  ( $V$ ) Amplifier will be described here.

An active low-pass filter, Q315 and Q309, removes the high-frequency components of the demodulation process and determines the rise time and delay of the demodulated signal.

The output from the non-inverting amplifier, Q408, Q404, and Q304, feeds back to a clamp circuit consisting of U211 and Q215. U211 is an operational transconductance amplifier used in a sample-and-hold circuit. The front-panel VECTOR VERT POS control is the reference for the clamp and causes an offset in the output signal. The Vector Clamp pulse strobes U211 at a line rate. Storage capacitor C215 holds the output level until the next sample.

The stored level is applied through source follower Q215 to the bias input of the  $R-Y$  ( $V$ ) Demodulator, thus setting the dc level for the output amplifier. This has the effect of moving the trace on the crt up or down vertically.

A jumper on J112 is provided as a troubleshooting aid to find problems in the Demodulator Output Amplifier loop. In the T (Test) position (pins 2-3), the clamp output is disabled by shorting the hold capacitor, C215. This effectively opens the feedback loop.

A jumper on J801 is a calibration aid that is used to match the gains of the crt output amplifiers on the Vertical (A3) and Horizontal (A4) boards. When J801 is connected to pins 1-2, the  $B-Y$  output of the Demodulator is directed to both crt output amplifiers.

### SCH Rephase

U135 is a differential pair with current source. The current source is driven by CW2, a subcarrier frequency signal which is phase locked to the 50% point of the leading edge of horizontal sync. The differential pair of U135 is driven by the regenerated subcarrier from diagram 5.

If the two signals (Subcarrier and CW2) are  $90^\circ$  out of phase (either leading or lagging), the output at pin 8 of U135 will be at a voltage sufficient to trip comparator U477B, so its output goes high. This may only happen during the sample interval dictated by CW2 SEL, which goes high during burst in field one where SCH phase is defined. When CW2 SEL is high, it turns off Q570, so the output of U135 is no longer shunted off.

A high pulse from the output of U477B signals the SCH Logic board that the SCH phase sequence has advanced one field. When the SCH Logic board reassigns the field sequence, the crt SCH vector will flop  $180^\circ$ , maintaining the SCH vector in the left-hand two quadrants of the display.

### SCH Logic Board (A9)

The SCH Logic board generates timing and gate signals used by circuitry throughout the instrument. It also creates waveforms for the SCH Mode display.

Upon receiving status from sources throughout the instrument, digital logic on the SCH Logic board generates timing for sweep modes on the Horizontal board. Gate signals for switching on the Horizontal and Vertical boards are output after the SCH Logic board polls status from the front panel and remote interface.

The SCH Mode display signals originate from the SCH Logic board, and drive the Demodulator board (A5). The output is in a vector format.

## SCH VCXO's

Circuitry on the SCH VCXO's schematic has two independent oscillators which run at four times subcarrier frequency, and are divided down to provide timing references to circuits throughout the instrument. One oscillator is phase locked to the internally selected sync source, and this derived clock is used to generate the SCH Mode display.

The other oscillator is phase locked to either the internal or external sync source, as selected on the front panel or remote control.

Digital logic divides the two oscillators down to subcarrier rate to provide line and field rate pulses for timing on the Horizontal, Vertical, and Demodulator boards. More line rate and field rate decoding is performed by circuitry shown on schematic 8.

### SCH Clock Generator

The 4Fsc Voltage-Controlled Oscillator (VCO) is regulated by a voltage from the Horizontal board (A4). This voltage regulates the frequency of the oscillator so it is phase locked to the 50% point of the leading edge of horizontal sync, of the A or B input as selected on the front panel or remote control.

The crystal oscillator formed by Y691 and C693 is regulated by center-frequency adjustment C694 and varactor CR697. The oscillator is passed through ECL buffer U592, and converted to TTL signal levels at U493. The 4Fsc clock is divided down to subcarrier rate by U392.

### SCH I/O Latch

U581 is an eight-bit latch which clocks the phase-locked subcarrier through to a differential pair, Q625 and Q628. The output from this pair is filtered to pass only the fundamental frequency sine wave, which is output to the Demodulator board for display when the SCH Mode is selected.

When in SCH Mode, this signal is demodulated against reference subcarrier on the Demodulator board. Since the signal is regenerated subcarrier (phase locked to the 50% point of the leading edge of horizontal sync), its display in Vector form is a single vector, with phase representative of SCH Phase.

Signals PDW1 (phase detector enable) and SCH1 (SCH calibrate enable) are gating signals, controlling (on the Horizontal board) the interval when SCH references are taken from the internally selected (A or B) signal.

### SCH Intra-Line Decoding

U276 is a Logic Sequencer which decodes the SCH Mode gating signals and clamp gating signals. Inputs to U276 are the SCH Reference Clock Generator, stripped internal sync from the Horizontal board (A4), and references from the front panel indicating operating modes. U276 is termed an intra-line decoder because it only derives signals occurring at a line rate.

### Reference Clock Generator

The Reference Clock Generator is a 4Fsc VCO, divided down to subcarrier rate, which is very similar to the SCH Clock Generator. It provides the clock reference which is later used to derive horizontal sweep modes, line select signals, and color frame decoding.

Unlike the SCH Clock Generator, however, the Reference Clock Generator can be phase locked to either internal or external sync (the sync is stripped on hybrid IC U360), or remote sync from the remote jack on the rear panel.

The sync source selection between internal and external sync is performed on the Horizontal board (A4) and controlled by the front panel or remote. The selection between these sync sources and Remote Sync is performed by U744, controlled exclusively by a pin on the remote control.

Decoding of line and field rate reference signals is performed by circuitry shown on diagram 8.

### Reference I/O Latch

The circuitry of the Reference Output Latch is very similar to that of the SCH Output Latch. They differ in that the Reference Output Latch provides signals which indicate color framing errors between the external reference and the internally-selected signal, and it provides gating signals for this function. The 1750-Series shows color framing errors when in SCH Mode with External Sync source selected.

The differential pair formed by Q538 and Q638 passes a single-ended sine wave to the Demodulator. This signal is used in the rephase circuit to determine when the SCH reference sine wave needs to be shifted 180°. This happens when the color frame sequence is redefined by a subcarrier-to-horizontal sync (SCH) phase shift.

## Power Supplies

U666 and U686 are monolithic voltage regulators which provide two independent  $-5$  V supplies. The two supplies are separate to insure isolation between the SCH Clock and the Reference Clock Generators.

The  $+15$  V supply is unregulated, and the  $+5$  V supply is regulated by the Low Voltage Supply on (A6).

## SCH LOGIC

### Reference Intra-Line Decoding

In a manner similar to the SCH Intra-Line Decoding shown on Schematic 7, Logic Sequencer U309 and PAL U111 decode line rate information for horizontal sweep generation, dc restoration, and several gating functions used by the Horizontal and Demodulator boards.

U302 divides down the  $4/5$  subcarrier rate reference from 7 and outputs this as an eight-bit word to U309 and U111. U309 is a Logic Sequencer which outputs on each line signals for SCH Phase Mode calibration (PDW2 and SCHW2), sync tip and back porch sample gates (ST SAMP2 and BP SAMP2) for the 50% point detector circuit on the Horizontal board, and the reference vertical clamp gate (VCLAMP2).

U111 derives more intra-line information; VECT CLAMP, which clamps the center dot in Vector and SCH Mode displays, BURST GATE, which gates the phase lock of the subcarrier regenerator on the Demodulator board (A5), IF CLOCK, which becomes the reference line clock after it is latched by U149, and SCH BLNK and DGATE, which remove glitches in the SCH Mode display and provide a gate to the subcarrier demodulator, respectively.

Clock pulses and timing information are passed to the Line Counter and Intra-Frame decoding and Sweep Gating circuits to generate more timing and gate functions.

### Line Counter and Intra-Frame Decoding

U601 is a counter which maintains the five low-order bits of the 10-bit word indicating the current line count in the frame. The five high-order bits are maintained internally in Logic Sequencer U809. U809 decodes this count, to provide frame rate timing signals.

U809 outputs a field reference signal (FGATE) to the sweep gating circuit to control one- and two-field ramps. Other signals decoded by U809 include the horizontal rephase (REPHASE) signal and line select blanking signal, which are also output to the sweep gating circuit.

## Sweep Gating

Sweep gating circuit derives signals used to control the horizontal sweep generator on the Horizontal board (A4). U259 is a logic sequencer which takes inputs from the reference intra-line decoding and line counter and intra-frame decoding circuits to derive horizontal sweep gates and Z-Axis amplitude gating.

U149 is a latch which relays the reference line clock (LNCLK) and some gating signals. U355B is a flip-flop which toggles to provide the SWEEP GATE signal for horizontal trace and retrace to the Horizontal board (A4), as controlled by TRACE and RETRACE from U259.

## Line Select

U609 compares a nine-bit word from the front panel and dip-switch S305 (S305 contains the MSBs) to identify the line to be displayed when LINE SELECT is active. U609 asserts the signal PRESEL during the line preceding the line in which line-selected active.

U511 and U501 also decode the selected line number into three seven-segment display numerals, and multiplex this to the front-panel displays. Display is output one digit at a time by selectively enabling current to flow in only one of the three common cathodes, switched by U511.

## Color Frame Identification

Three ICs, U121, U137, and U332, maintain the color frame reference of the four-field sequence in NTSC and the eight-field sequence in PAL. This reference is very important in determining the correct SCH display, as SCH phase is dependent on the color frame field sequence.

U121 and U137 act as a broad pulse detector, to identify the broad pulses in the vertical interval. U121 is a counter which is cleared (loaded) by STCTR (horizontal line start-up and center). If broad pulses in the vertical interval are detected, U121 will count up. U137 is a PAL which recognizes the relationship between horizontal and vertical sync, and in the 1751 recognizes the burst blanking sequence.

U332 is the Color Frame Lock circuit, a PAL which, depending on the operating mode, outputs unblanking signals to the Z-Axis amplifier on A1. U332 looks at the subcarrier-to-horizontal phase of the reference every four (NTSC) or eight (PAL) fields to decode the color field sequence.

## Demodulator Source Selection

U461 is a PAL which, depending on the instrument operating mode and the time instant within a line color frame,

selects the source for the Chroma Demodulator on A5. The source is selected as either internal (selected signal source A or B) or the internally-generated CW1 for the SCH Mode display.

U422 also provides the Chroma Gate signal to the Demodulator board, as well as signals to another part of the SCH Logic board continuous wave subcarrier outputs to the Demodulator board. These signals are disabled when they are not needed, to help prevent cross-talk on the Demodulator board.

## **INTERFACE AND HV POWER SUPPLY (A1); CRT CONTROL (A7); FRONT PANEL (A8); AND LOW VOLTAGE POWER SUPPLY (A6)**

Diagram 10 shows the HV and CRT circuits. This is the last functional block in the input signal path, the display. The CRT display, the display control circuits, and the display power supply are shown on this schematic. Circuits are included from assemblies A1 and A7.

Diagram 12 shows the Front-Panel Signal Controls. All of these circuits are on the Front-Panel assembly (A8).

Diagram 9 shows the Interface and Remote circuits and connections. These circuits are all included on the Interface and HV Power Supply board (A1).

Diagram 6 shows the low voltage supply, which outputs low voltages for the entire instrument.

### **HV and CRT**

The cathode ray tube (crt) operates with electrostatic deflection, and provides a trace on an 8 by 10 cm display area. The crt is adjustable for brightness, focus, astigmatism, geometry, and horizontal and vertical alignment.

The High Voltage Supply on A1 is driven by the main Low Voltage Power Supply transformer, T252 on (A6), shown on diagram 11. Voltages are provided for the cathode,  $-3$  kV, and the Post Accelerator (Anode),  $+12$  kV. In addition, voltages are provided for the beam control and geometry elements of the crt. The Scale illumination circuit and the operator-adjusted crt controls are also included.

### **High Voltage Supply**

The High Voltage Supply block generates the post and cathode voltages. Q933 oscillates and provides one of the T838 primaries with a 50-V (from the low voltage supply) sine wave, which is stepped up by T838 and further multiplied by U638. The output from U638 provides the  $+12$  kV post acceleration potential. The output from this same secondary of T838 is rectified and provides the  $-3$  kV potential. The  $-3$  kV output is filtered before connecting to the cathode at the crt base socket.

The  $-3$  kV supply is regulated by controlling the current in the T838 primaries, thus providing indirect regulation for the 12 kV supply. Feedback for regulation is provided by voltage division from a thick film resistor array R632, followed with isolation by U752. This current is fed back to the base of Q753, driving Q855. The current output from Q855 regulates the current in one of the T838 primaries.

The filament winding of the transformer is referenced to the cathode voltage to avoid cathode leakage currents. DS824 is a neon lamp which keeps these two crt elements within 100 V of each other if the crt arcs.

Crt beam current is controlled by the grid voltage at crt pin 3. Since pin 3 is also near  $-3$  kV, circuitry is included so control of the beam current is possible with low voltage circuits. The Z-Axis input is a two-level signal. The low level blanks the crt, and the high level sets the brightness of the display. These two levels come from the Intensity Control and Z-Axis Output circuits.

CRT Bias adjustment R512 is set to just blank the crt with the INTENSITY control set to minimum. DS823 and DS822 keep the control grid voltage close to the cathode voltage if the crt arcs.

The focus grid voltage, crt pin 4, is also controlled by a low voltage circuit. The front-panel FOCUS control sets the output voltage of operational amplifier Q764, Q866, and Q865. This voltage sets the voltage at one end of a voltage divider. The other end of the divider is referenced to the cathode voltage. The Focus Center control, R533, part of the divider, is adjusted for display focus with the front-panel FOCUS control centered.

The focus voltage is also changed when the instrument is placed into line select mode. When in line select, the MAG3 line goes low, and the output from U547 at pin 2 will add current to the current provided by the front-panel focus control.

## CRT Alignment

Several additional controls complete the adjustment of the display. The Astigmatism control, R551, is used in conjunction with the FOCUS control to adjust for the best spot size. The Trace Rotation control, R105 on the Low Voltage board A6, is used to align the horizontal trace to the Waveform Graticule. The Y Alignment control, R101 on the Low Voltage board, and Geometry control, R514, are used to adjust vertical lines of the display to be vertical and straight.

## Scale Illumination Control

This circuit is used to vary the brightness of the grati-cules. Two sets of lights are provided. The front-panel SCALE illumination control varies the voltage on one input to differential amplifier U776B. The other input to U776B is a 6-kHz, square wave output by U776A. By varying the SCALE pot, the duty cycle at the output of U776B will vary, effectively controlling the output of the graticule lights.

## Intensity Control

Display intensity is controlled by both blanking and brightness inputs. Blanking inputs may be from the sweep circuits, during low level vector signals, or from the External Blanking input at the rear-panel REMOTE connector.

A high level at TP568 (approximately 2 V) blanks the crt. U564 is used as a switchable current source. The transistor with its base connected to pin 12 is the current source. Its base voltage is set by the front-panel INTENSITY control and another current source Q678. The emitter current of Q678 is determined by the front-panel sweep mode switches, which control the three signals MAG1, MAG2, and MAG3. As higher writing rates are chosen, more beam current is provided.

## Z-Axis Output

This amplifier converts the current from U564, pin 8 or 5 (determined by the INTENSITY setting), to a voltage, and drives the crt control grid circuit. During blanking, when U564 output current is zero, the output at TP558 is approximately 5 V. After blanking, the intensity current determines the high level output.

R770 is the feedback resistor of an operational amplifier, Q764, Q866, Q865, and Q765. Q764 is capacitively driven by Q765 for fast, positive, output transients with minimum quiescent power. Q866 isolates Q865 from negative output transients which would otherwise reduce the available base current for Q865.

## CRT Controls (A6),

Five knob controls and four screwdriver controls, located just below the front of the crt, are provided for adjustment of position, gain, intensity, scale illumination, and focus. The functions of these controls are discussed as a part of other circuits.

## Front-Panel Signal Controls (A8),

The Front-Panel assembly (A8) is shown on this schematic. All front-panel controls are shown here. All labeled functions are active when the switch push buttons are in. The +V/PAL switch on the 1751 is in PAL when the switch is out, and +V when the switch is in. The common switch lines are all low when the Front-Panel enable signal is active, and high when Remote control is enabled.

The VARIABLE GAIN control, R510, controls the Variable Gain Amplifier on the Vertical board (A3) when out of detent (UNCAL). When in detent (CAL), the control has no effect. The VARIABLE GAIN control lights the UNCAL light, DS910, when out of its detent position.

## Interface and Remote

### Interface

The interface is the main interconnect for the instrument, eliminating most cabling. It is a part of circuit board A1 located at the bottom of the instrument.

Four 64-pin connectors are provided to interconnect the Demodulator (A5), Horizontal (A4), Vertical (A3), and SCH (A9) boards to the Interface (A1), Front-Panel Control (A8), and the Power Supply (A1 and A6). The 64-pin connectors are connected in parallel. The Vertical and Horizontal board connectors (J437 and J237) are reversed because the parts on the circuit board face in the opposite direction. This schematic also includes the remote connector functions.

### Remote Control

Remote Control transfers control by the front-panel push buttons to inputs at the two REMOTE connectors. The remote connectors on the rear-panel are J205 and J505 on the Interface board (A1). The features of the remote function are listed below.

1. All of the push-button controls may be remotely controlled by ground closures.
2. If Remote Mode is chosen, all of the front-panel switches (except POWER) are remoted.

3. A ground is provided at pin 1 so that a plug could be installed which programs the instrument to one setup of the customer's choice.
4. Each of the functions can be separately controlled by ground closures to the appropriate pin.
5. If no ground closures are provided there is a default display.
6. If two mutually exclusive functions have been chosen there is a hierarchy that the remote function allows. The defaults and hierarchy are included in the Installation section of this manual.
7. The Remote Mode may be selected by a ground closure to pin 13 if J508 is set to the 2-3 position; if J508 is set to the 1-2 position, a +12 V activates remote control.

Several additional functions are controlled from the REMOTE connector. Among these are:

1. A Parade display can be used for camera control adjustment.
  - a. An RGB enable (pin 25) and a Staircase input (pin 19) must be supplied by the Camera Control Unit. The RGB Enable shortens the trace, and the Staircase input places three or four successive sweeps sequentially on the display.
  - b. J612 on the Horizontal board (A4) selects the sweep attenuation for 1/3 or 1/4 normal.
2. External Blanking may be used (pin 6). This blanking is ORed with the internal blanking from the Horizontal and Demodulator circuits.
3. Five additional line select bits are available on pins 1-6 of J505, in addition to the four bits set by the front-panel switch. This gives the capability of selecting a block of 16 lines anywhere in a field (odd and even) sequence. These are the five MSBs of the line-of-field count indicator. In normal operation with no remote connected, these bits are all high, which selects the first 16 lines of a field, which is in the vertical interval.
4. Remote Sync, which operates with non-composite or non-video signals, is also input through J205.

### Low Voltage Power Supply (A6)

The Low Voltage Power Supply provides the power required by the circuits in the instrument, and is a continuous-mode, flyback-switching power supply. Line voltage is rectified and feeds switching circuitry operating at 100 kHz. The output of this circuitry drives the primary of a trans-

former, with secondary outputs filtered to provide the respective low voltages. Feedback for regulation is taken from the 5 Volt supply.

### Input and Line Rectifier

The power source for the instrument is ac power from the Interface board, A1. This supply voltage, after it is low-pass filtered by RC682, T686, C793, and C795, feeds the voltage doubling circuit consisting of CR278 (bridge rectifier), C268, and C479.

The voltage doubling effect, in with 115 V operating mode, but not in 230 V mode (mode determined by S230 and S296), occurs because the peak voltages from the 115 V rms supplies (about 165 volts) are stacked on the series combination C268 and C479. This results in a dc voltage, referred to the (–) output of CR278, of over 300 Vdc. DS770, a neon bulb, indicates high voltage present on the doubling capacitors. The noise created by the switching transistors is decoupled by L773.

### Switching Primary

The heart of a switching power supply is the switching semiconductors which regulate the power in the transformer primaries. In the 1750-Series supply, Q447 and Q452 provide this function.

Switching is done at a frequency much higher than the power line frequency, in order to reduce the size of the power transformer, and provide a very steady, regulated output. Switching is continuous mode, meaning flux in the power transformer, T252, is always unipolar and continuous. Thus, current in the secondaries is also unipolar.

Mosfets Q447 and Q452 are series switches to the primary of T252. When the leading edge of a voltage pulse is emitted from U529, T635 passes the pulse to the gates of the mosfets, charging the gate-source junctions and turning them on. This applies the 300 Vdc from the rectified line voltage to T252. The magnetizing current then marginally increases in the primary of T252, increasing the energy storage.

When the pulse from U529 goes low, Q472 and Q642 turn on and short out the gate-source junctions of Q447 and Q452, turning them off. Although current in the mosfets is then zero, current in the T252 primary will momentarily continue to flow through the damping diodes, CR440 and CR456. The secondary diodes then conduct, and energy is transferred to the load.



## Theory of Operation—1750-Series

The current through the primary, and thus the power through the primary and secondary, are controlled by the duty cycle of the switch pulse emitted by U529. This pulse is regulated by U529 in order to maintain the 5 V supply voltage, which is also affected by variations in load in the other supplies.

### Pulse Width Modulation

The pulse width modulator, which controls the power delivered to power transformer T252, is based upon U529. It operates by changing the duty cycle of the square-wave pulse output at pin 8, based on feedback provided by the 5 V supply.

Feedback voltage is determined by the voltage on C416, which integrates the pulse output from T415 (T415 is necessary to maintain isolation between the T252 primary and secondary). The voltage on one side of C416 is determined by a precise 5 V reference generated internally by U529, and output at pin 14.

Primary undervoltage and secondary overcurrent conditions are sensed by Q430, Q432, and Q427. Q427 also provides a reference voltage used to soft-start U529 after overcurrent or undervoltage conditions have caused a shut-down. Normal operation begins after sufficient time to allow the voltage on C424 to decay to the proper reference voltage.

### Start Up

Under steady state conditions, U529 relies on power supplied by a separate winding in the power transformer, T252, passed through CR345 and Q537. The winding will

not supply power unless current flows in T252, which is dependent on a pulse sent out by U529 to turn on the switching transistors. The start-up circuit provides a brief surge of power to bring the supply circuitry up to speed.

When ac power is first applied to the power supply, a small current flows from the rectified line voltage through R340. This current charges C342, until it holds enough charge to forward-bias Q439. A brief supply voltage is then delivered through Q537 to U529, for more than enough time to bring the power supply to a steady-state mode of operation. The start-up circuit also operates in a similar fashion after the power supply has shut down due to undervoltage or overcurrent conditions.

### Filtered Outputs

Since all outputs resemble it, the +15 V output will be discussed.

The pulse outputs from the power transformer, T252, charge the filter capacitor C126. L510 and R513 provide stable filtering under widely varied load conditions. The +15 V pre-regulated output is used in conjunction with on-board monolithic regulator ICs throughout the instrument. The monolithic +12 V regulator, U600, supplies power for front-panel circuitry (as does U504 for -12 V).

The 5 V supply is regulated very precisely through the feedback loop, which controls the switching supply current. No further regulation is necessary. The +46 V supply is regulated indirectly through the 5 V feedback loop, but is most susceptible to variations.

# CHECKS AND ADJUSTMENTS

This section consists of two separate procedures. The first, a Performance Check, is used to determine compliance with the Performance Requirements in the Specification. The second is the Adjustment Procedure, which provides the instructions on how to adjust the instrument and return it to operation within the specification.

In both procedures, front- and rear-panel controls and connectors on the instrument under test are fully capitalized (e.g., VARIABLE GAIN). Control and connector names on test equipment and internal controls and adjustments for the instrument under test are initial capitalized (e.g., Time/Div, Geometry, etc.).

Limits, tolerances, and waveforms given in this section are guides to adjustments and checks, and are not instrument specifications except when listed in the Performance Requirement column of the Specification section of this manual.

## RECOMMENDED EQUIPMENT LIST

### Electrical Instruments

#### 1. Test Oscilloscope

Vertical Amplifier: 30 MHz Bandwidth, 1 mV Sensitivity.  
Time Base: 10 ns/div to 5 ms/div sweep speeds,  
Triggering to 5 MHz.

For example; a TEKTRONIX 7603 Oscilloscope with a 7A18 Dual-Trace Amplifier, a 7A13 Differential Comparator (needed for use with the TEKTRONIX Return Loss Bridge), and a 7B53A Dual Time Base. Also 10X probes, P6106 (Tektronix Part No. 010-6106-03), and a 1X probe, P6101 (Tektronix Part No. 010-6101-03).

#### 2. Television Signal Generator

Color Test signals for the television standard of the monitor to be tested: Color Bar signal, Linearity Staircase and Variable APL, Pulse and Bar; with 2T Pulse, 2T Bar, and modulated pulse, Field Square-wave signal, and Black Burst signal.

For example: NTSC TEKTRONIX 1410 with Option AA and Option AB (modified SPG2 and TSG7), TSG3, and TSG5.

PAL TEKTRONIX 1411 with Option AA and Option AB (modified SPG12 and TSG11), TSG13, and TSG15.

#### NOTE

*The 1410-Series generators with standard SPG and TSG modules can be used, but not all checks and adjustments can be made. A standard SPG2 or SPG12 module will not check lock to changes in sync amplitude, cw lock to changes in burst amplitude, and frequency lock to burst offset frequency changes (Performance Check step 17 and Adjustment Procedure steps 19 and 20). A standard TSG7 or TSG11 can not check Performance Check step 16 and Adjustment Procedure steps 17 through 20.*

The 1410, and 1411 Option AB are mainframes with modified TSG7 and TSG11 Color Bar generators that provide more accurately controlled output amplitudes.

The signal generators can be ordered with one or both options (AA and AB).

The TSG3 and TSG13 are Modulated Staircase generators with variable APL.

The TSG5 and TSG15 are Pulse and Bar generators with Modulated Pulse and Field Square wave signals.

#### 3. Swept Sine-Wave Generator Sine Wave signal 50 kHz to 10 MHz.

The CW signal can be used as time marks.

For example: HP3336C, Option 005 (which provides increased flatness and attenuator accuracy ( $\pm 0.07$  dB flatness in CW mode). The standard frequency accuracy ( $\pm 5$  parts per million of programmed frequency) is sufficient for time base calibration and verification.

or: A TEKTRONIX SG 503 Leveled Sine-Wave Generator installed in a TEKTRONIX TM 500 Series Power Module. Flatness  $\pm 1\%$ , 250 kHz to 50 MHz. The flatness can be calibrated (a chart made of variations) with the TEKTRONIX Peak to Peak Detector (015-0408-00). The frequency can be measured with the frequency counter to adjust and check the time base of the 1750-Series. The disadvantage of the SG 503 is that it is not a swept frequency generator.

## Checks and Adjustments—1750-Series

When using the TEKTRONIX SG 503 these additional accessories are needed; 50  $\Omega$  coaxial cable, Tektronix Part No. 012-0057-01, and a 50 to 75  $\Omega$  min loss attenuator, Tektronix Part No. 011-0057-00.

### 4. Voltmeter

Range, 0 to greater than 100 Vdc; accuracy,  $\pm 0.1\%$

For example: TEKTRONIX DM 501A in a TM 500 Series Power Module.

### 5. Frequency counter

Range, 100 kHz to 5 MHz; accuracy,  $\pm 0.001\%$

For example: TEKTRONIX DC 503A in a TM 500 Series Power Module.

### 6. Square wave and sine wave Function Generator

Range; 0.1 to 5 V p-p when loaded by 75  $\Omega$  10 V p-p when unloaded, frequency; 10 Hz to 2 kHz

For example: TEKTRONIX FG 503 in a TM 500 Series Power Module.

### 7. Video Amplitude Calibrator

Signal; adjustable square wave 0.0 to 999.9 mV p-p with a resolution of 0.1 mV and an accuracy of 0.05%, frequency approximately 270 Hz.

For example: TEKTRONIX 067-0916-00 in a TM 500 Series Power Module.

### 8. Peak to Peak Detector

Detector to calibrate sine wave source flatness. Input signal range 0.25 to 1.0 V p-p, flatness  $\pm 0.2\%$  50 kHz to 10 MHz, Input Impedance 75  $\Omega$ .

For example: TEKTRONIX Peak to Peak Detector 015-0408-00.

### 9. Power Module (required for Items 4, 5, 6, 7, and 8)

For powering and housing TEKTRONIX DM 501A, DC 503A, FG 503, 067-0916-00, 015-0408-00.

For example: A TEKTRONIX TM 506 Power Module.

### 10. Variable Autotransformer

For example: General Radio Metered Auto Transformer W10MT3W. If 220-Volt operation must be checked a conversion transformer or appropriate 220-Volt auto transformer is needed.

## Auxiliary Equipment

### 11. Step Attenuator

75  $\Omega$  constant impedance attenuator variable from 0 to 40 dB in 1 dB steps.

For example: HP 3750A Attenuator, 0-99 dB.

### 12. Return Loss Bridge

Range; at least 46 dB return loss sensitivity, 50 kHz to 6 MHz.

For example: TEKTRONIX 015-0149-00

If the Tektronix Return Loss Bridge is used with a 50  $\Omega$  sine wave generator, such as the TEKTRONIX SG 503, these additional accessories are needed; 50  $\Omega$  coaxial cable (Tektronix Part No. 012-0057-01) and a 50- to 75  $\Omega$  minimum loss attenuator (Tektronix Part No. 011-0057-00).

### 13. 75 $\Omega$ Terminators

Three required, one should be a feedthrough type.

For example: End-line 75  $\Omega$  terminator (Tektronix Part No. 011-0102-00), and a feedthrough 75  $\Omega$  terminator (Tektronix Part No. 011-0103-02).

### 14. Coaxial cable

Three required.

For example: 42 inch RG 59U (Tektronix Part No. 012-0159-00).

### 15. 10X, 75 $\Omega$ Attenuator

For example: Tektronix Part No. 011-0061-00.

### 16. Alligator clip to BNC adaptor.

For example: Tektronix Part No. 013-0076-00.

### 17. Dual Input Coupler

Matched BNC cable-T for making phase comparisons between two inputs. Matched length of the two arms within  $\pm 0.1$  in.

For example: Tektronix Part No. 067-0525-02.

### 18. Parade Display Test Connector

Remote connector modified to enable and test the RGB parade input. See Fig. 5-1.

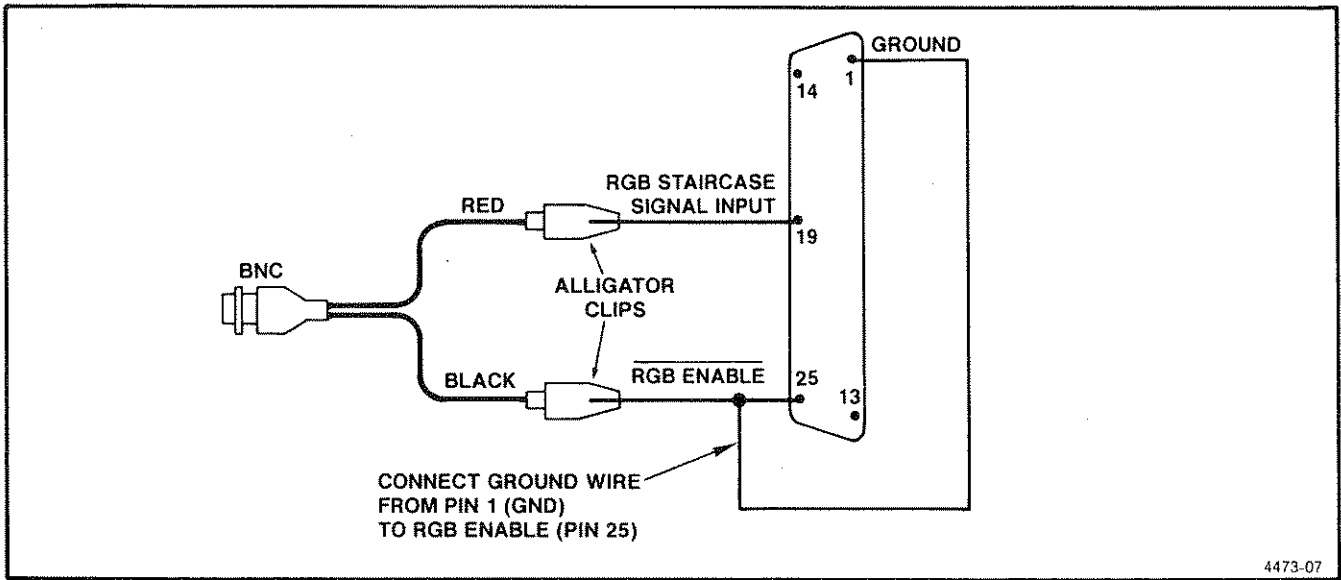

Fig. 5-1. RGB parade display test connector.

**20. Alignment Tool**

For adjustment of small pot core coils needing a two-pronged blade.

For example: Tektronix Part No. 003-0837-00.

**21. Alignment Tool**

For adjustment of coil cores needing a small hex shaft.

For example: Tektronix Part No. 003-0310-00.

## PERFORMANCE CHECK

The short-form procedure is intended for those who are familiar with the complete Performance Check procedure. Step numbers and sub-step designations correlate directly to the steps in the Performance Check Procedure; this makes it possible to use the Short-form Procedure as a table of contents.

### POWER SUPPLIES AND CRT ALIGNMENT (Assemblies A1 and A6)

#### 1. Preliminary Setup.

- a. Connect autotransformer.
- b. Connect composite Color Bar signal.

#### 2. Check Power Supply Operation

- c. Check for stable operation over line voltage range.

### HORIZONTAL BOARD (Assembly A4)

#### 3. Sync Separation

- a. Check instrument synchronization.

#### 4. Sweep Operation

- b. Check sweep modes.
- d. Check for 1H and 2H sweep rates.
- e. Check for 1FLD and 2FLD sweep rates.
- g. Check that some portion of field blanking is displayed.
- i. Check that some portion of horizontal blanking is displayed.
- j. Check that each field in 2H MAG SWEEP can be positioned onto the screen.

#### 5. Sweep Calibration

- c. Check 2H MAG SWEEP accuracy.
- e. Check 1H MAG SWEEP accuracy.
- g. Check 1H and 2H MAG SWEEP linearity.

#### 6. RGB/YRGB Parade Display

- c. Check shortened sweep length.
- d. Check sweep rate and magnification.
- e. Check range of HORIZONTAL POSITION control.
- g. Check added deflection.

### VERTICAL BOARD (Assembly A3)

#### 7. Vertical Gain

- b. Check vertical amplifier gain.
- d. Check IRE (LUM) Filter gain accuracy.
- f. Check 5X MAG accuracy.
- h. Check VAR gain range.
- j. Check CH-A vertical amplifier gain.

#### 8. Calibrator Amplitude and Frequency

- b. Check Calibrator frequency.
- c. Check Calibrator amplitude.
- d. Check that Calibrator is synchronized in 1H and 2H Sweep.
- e. Check that Calibrator free runs in 1FLD and 2FLD Sweep.

#### 9. PIX MON OUT Operation

- b. Check PIX MON OUT level.
- d. Check PIX MON OUT amplitude.

#### 10. DC Restorer Operation

- b. Check that DC Restorer operates.
- d. Check operation with 60-Hz hum.
- f. Check amplitude change when burst is turned off.
- h. Check amplitude change with APL change.

#### 11. Flat Response

- b. Check X1 Gain flat response.
- d. Check X5 Gain flat response.

#### 12. Transient Response

- b. Check preshoot, overshoot, and ringing.
- c. Check Pulse-to-Bar ratio.
- d. Check bar tilt.
- f. Check field tilt.
- h. Check X5 GAIN transient response.
- j. Check chrominance-to-luminance gain and delay error.

#### 13. IRE or LUM Filter Response

- b. Check IRE filter response (1750 only).
- c. Check LUM filter response (1751 only).
- e. Check amplitude difference from Flat Filter.

**14. CHROMA Filter Response**

- c. Check CHROMA Filter gain.
- e. Check CHROMA Filter frequency response.
- f. Check CHROMA Filter cutoff.

**DEMODULATOR  
(Assembly A5)**

**15. Demodulator Channel Bandwidth**

- b. Check bandwidth.

**16. Color Bar Decoding Accuracy**

- b. Check vector angle and amplitude accuracy.
- d. (1751) Check that vectors can be overlaid.

**17. Subcarrier Regenerator Performance**

- c. Check lockup.
- d. Check frequency stability.
- f. Check amplitude stability.

**18. Phase Accuracy**

- b. Check CH-A, CH-B phase match.
- d. Check EXT REF phase accuracy.
- e. Check burst jitter.
- g. Check differential phase on R-Y (V-Axis).
- i. Check phase change with chrominance amplitude change.

**19. Amplifier Linearity**

- b. Check differential phase.
- d. Check differential phase of CHROMA Filter.

**20. Chrominance Vector Clamp Performance**

- b. Check clamp phase stability.
- d. Check range of VECTOR POSITION controls.

**21. X5 GAIN and VARIABLE GAIN in Vector Mode**

- d. Check VARIABLE GAIN range.
- f. Check VARIABLE GAIN range with X5 GAIN.

**22. INPUT and PIX MON OUT Return Loss**

- b. Check Input loop-through return loss.
- d. Check PIX MON OUT return loss.

**23. Acquisition Time and Accuracy**

- e. Check sync dot position.

**24. Display Range**

- d. Check display range.

**25. Channel and Reference Match**

- e. Check sync match (A to B).
- f. Check int to ext reference match.

**Performance Check Procedure**

The following preparations should be made before attempting the Performance Check.

Set the 1750-Series up as shown in the table that follows. After a numbered step has been completed, return the 1750-Series controls to the conditions in the table below, unless otherwise noted.

POWER	ON
INTENSITY	Set to Operator's preference
FOCUS	
SCALE	
VERT POS	
HORIZ POS	
Push Buttons Depressed	
WFM	
2H	
FLAT	
INPUT B	
VARIABLE GAIN	Detented
CH A INPUT	HI Z

**POWER SUPPLIES AND CRT ALIGNMENT  
(Assemblies A1 and A6)**

**1. Preliminary Setup**

a. Connect the variable autotransformer to the AC power connector. Turn Power On and set the autotransformer for the voltage shown by the rear-panel Line Voltage Selector switch.

b. Connect a Composite Color Bar signal with 100% Peak White Bar and 75% amplitude Color Bars through the CH-B INPUT and terminate the opposite side of the loop-through with a 75  $\Omega$  termination.

## Checks and Adjustments—1750-Series

### 2. Check Power Supply Operation

REQUIREMENT—Check ac input range, 90-132 V, 200-250 V as determined by the line voltage selector.

a. Turn on the 1750-Series and adjust the controls for a usable display.

b. Vary the autotransformer from low line to high line voltage (as dictated by the line voltage selector switch).

c. CHECK—for stable operation over the voltage range.

## HORIZONTAL BOARD (Assembly A4)

### 3. Sync Separation

REQUIREMENT—Check for stable sweep synchronization with the table of signal types and amplitudes below.

a. CHECK—that the 1750-Series instrument can be synchronized with the conditions below. Use the 2H and 2 FLD SWEEPS to check for stable triggering.

Reference Source	Signal	Amplitude of Sync
Internal	Composite	143 mV to 572 mV
	Video	(150 mV to 600 mV for 1751)
EXT REF	Composite	143 mV to 4 V
	Sync	(150 mV to 4 V for 1751)
	or Composite Video	

#### NOTE

Use the 1410-Series Option AA Variable Sync Amplitude control to vary the amplitude of sync on the composite video output. The limits of the control will vary the sync amplitude to 0.5 and 2 times normal amplitude. If the 1410-Series Option AA is not available use the Step Attenuator for signal amplitude changes. Remove the Loop-Thru terminator. The Step Attenuator will be set to 0 dB and 12 dB attenuation to obtain 2 times and 0.5 times standard sync amplitude.

### 4. Sweep Operation

REQUIREMENT—Check that the sweep rate controls operate correctly. Check for sweep mag registration (some

part of the blanking interval is visible when magnifying the centered 2H and 2FIELD sweeps).

a. Display INPUT B with nothing connected.

b. CHECK—that a sweep occurs in each SWEEP mode (1H, 2H, 1FLD, 2FLD)

c. Connect the Color Bar signal to the CH-B INPUT.

d. CHECK—that the 1H and 2H SWEEP modes display one line and two lines of the Color Bar respectively.

e. CHECK—that the 1FLD and 2FLD SWEEP modes display the Color Bar field and frame correctly.

f. Select and center the 2FLD SWEEP. Select MAG SWEEP mode.

g. CHECK—that some portion of the Field Blanking interval is displayed.

h. Select and center the 2H SWEEP. Select MAG SWEEP mode.

i. CHECK—that some portion of the Horizontal Blanking interval is displayed.

j. CHECK—that each portion of the 2H MAG SWEEP can be positioned onto the display with the HORIZONTAL POSITION control.

### 5. Sweep Calibration

REQUIREMENT—Sweep timing accuracy: magnified 1H and 2H sweeps (1  $\mu$ s/div within 2%, 0.2  $\mu$ s/div within 2%). Timing linearity: magnified 1H and 2H sweeps within 2%.

a. Connect the sine wave generator to the CH-B INPUT on the 1750-Series instrument.

#### 1750-Series Instrument Setup

2H MAG	
CH-B	Sine Wave Generator
X5 GAIN	

**HP3336C Setup**

Sweep Single  
 Data 1 MHz  
 Amplitude 0 dBm

b. Excluding the first and last divisions of the unmagnified display, position several portions of the 2H MAG SWEEP to the display and check the timing of the display. See Fig. 5-2.

c. CHECK—for 11 tips of the 1-MHz sine wave displayed within the central 9.8 to 10.2 div.

d. Change HP3336C Data to 5 MHz.

e. CHECK—for 11 tips of the 5-MHz sine wave displayed within the central 9.7 to 10.3 div.

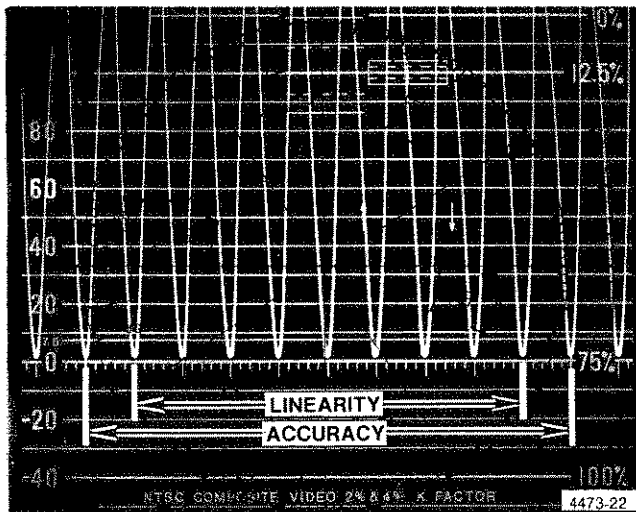

MEASURE TIMING ACCURACY  
 BETWEEN CENTER 10 DIVISIONS

MEASURE TIMING LINEARITY  
 BETWEEN CENTER 8 DIVISIONS

4472-67

Fig. 5-2. Using triggered sine waves to make timing measurements.

f. Use the method of part b to check both the 1H MAG and 2H MAG sweep linearity in 10 divisions. Change the frequency of the generator to position the first and last sine wave tips in the central 10 divisions of the display to those major graticule marks. To change the frequency of the generator; depress Modify, select the digit of the frequency display to be modified with an arrow key, and vary that digit with the knob.

g. CHECK—that for both sweeps the intermediate sine wave tips fall at their expected locations within two tenths of a major division.

**6. RGB/YRGB Parade Display**

REQUIREMENT—Attenuated sweep: 3.4 to 4.1 div for 3 step or 2.5 to 3.1 div for 4 step. Staircase input gain: 10 V = 9 horizontal divisions  $\pm 1.4$  div. Attenuated sweep responds to sweep rate and magnification controls (1H or 1FIELD displays only).

a. Display the Color Bar in 1H. Center the display. Note the position of P685 on Assembly A4 that selects the 3- or 4-step parade display. The lower (2-3) position selects attenuation for a 3-step display.

b. Connect the Parade Display Test connector to the remote connector.

c. CHECK—that the sweep has shortened to 3.4 to 4.1 div if P685 is set to a 3-step display or 2.5 to 3.1 div if P685 is set for a 4-step display.

d. CHECK—that the shortened sweep is 1H or 1FIELD according to the SWEEP controls, and that the sweep can be magnified with the MAG push button.

e. CHECK—that the display can be moved to the sides of the screen with the HORIZ POS control.

f. Remove the Color Bar signal. Position the display to the right side of the screen. Connect a 0 to +10 V 2-kHz square wave to the BNC connector of the Parade Display Test connector as shown in the equipment list.

g. CHECK—that 8.6 to 10.4 divisions of deflection have been added by the square wave.

**VERTICAL BOARD  
 (Assembly A3)**

**7. Check Vertical Gains**

REQUIREMENT—Gains within 1%; 3% in X5 GAIN, for both CH-A INPUT and CH-B. Input signals between 0.7 and 2 V can be adjusted to full scale video amplitude with the VARIABLE GAIN control.



## Checks and Adjustments—1750-Series

a. Connect the Video Amplitude Calibrator (VAC) to the CH-B input. Set the VAC to 999.9 mV. Do not terminate the other side of the LOOP-THRU input.

b. CHECK—that the vertical amplitude of the display of the 1750 is 138.6 to 141.4 IRE (0.990 V to 1.010 V for the 1751). Note that the lines of the K Factor box are 2 and 4 IRE above and below the 100 IRE ( $+0.7$  V) graticule line ( $\pm 0.014$  V and  $\pm 0.028$  V for the 1751).

c. Select the IRE Filter (LUM Filter for the 1751).

d. CHECK—that the vertical amplitude of the display does not vary from that found in part b by more than  $\pm 1.4$  IRE ( $\pm 0.010$  V for the 1751).

e. Set the VAC output to 200 mV. Select X5 GAIN.

f. CHECK—that the vertical amplitude of the display of the 1750 is 136 to 144 IRE (0.970 V to 1.030 V for the 1751). Note that the lines of the K Factor box are 2 and 4 IRE ( $\pm 0.014$  V and  $\pm 0.028$  V for the 1751) above and below the 100-IRE (0.7 V) graticule line.

g. Release the X5 MAG button. Display the Color Bar Video signal with 100% White Bar. Two signal amplitudes are needed. First; the voltage from the blanking level to 100% peak white when normally terminated. Second; 2 V is the voltage from sync tip to 100% peak white with the terminator removed.

h. CHECK—that, with either input amplitude the display can be set to the full scale with the VARIABLE GAIN control.

i. Connect the VAC to the CH-A INPUT and set the VAC to a 999.9-mV square wave.

j. CHECK—that INPUT A meets the specifications listed in part b.

k. Disconnect the VAC from the 1750-Series instrument.

### 8. Check Calibrator Amplitude and Frequency

REQUIREMENT—Frequency 100 kHz  $\pm 0.1$  kHz, amplitude 1 V  $\pm 0.5\%$ . The Calibrator must be synchronized in 1H and 2H displays.

a. Connect a cable from the VIDEO OUT connector to the frequency counter. Display the CAL signal with the 2H sweep. Trigger the frequency counter to display the Calibrator frequency.

b. CHECK—that the frequency of the Calibrator is 99.9 to 100.1 kHz.

c. CHECK—that the displayed amplitude is 139.3 to 140.7 IRE (0.995 V to 1.005 V for the 1751).

d. CHECK—that the Calibrator is synchronized in both 1H and 2H Sweeps.

e. CHECK—that the Calibrator is displayed in 1 FIELD and 2 FIELD as a free running sweep.

### 9. Check PIX MON OUT Operation

REQUIREMENT—Gain from Input 1:1  $\pm 5\%$  at 15 kHz. Dc level within  $\pm 0.5$  V of 0 V.

a. Disconnect the input signal from the CH-B INPUT. Display INPUT B with the 2FLD sweep. Connect a Coaxial Cable from the PIX MON OUT to the oscilloscope. Use an inline terminator at the oscilloscope.

b. CHECK—that the level at the PIX MON OUT is 0 V  $\pm 0.5$  V.

c. Connect the Color Bar signal to the CH-B INPUT.

d. CHECK—that the amplitude of the Color Bar is within 0.95 to 1.05 V from sync tip to the 100% Peak White Bar, as displayed on the oscilloscope.

### 10. Check DC Restorer Operation

REQUIREMENT—Attenuation of 60 Hz input signal, with the inputs ac coupled, less than 20%. Blanking level shift with APL change, less than 1 IRE ( $\pm 1\%$  of the standard video amplitude from blanking to 100% peak white). Blanking level shift with presence or absence of burst, less than 1 IRE (7 mV) as above.

a. Connect the Modulated 5 Step Linearity signal (with AC Bounce on) to the CH-B INPUT. Display the signal with the 2H SWEEP. Select DC Restorer operation. Position the blanking level of the signal to the 0 IRE line.

b. CHECK—that the blanking level does not move when the variable GAIN is rotated and that the display moves slightly when the DC Restorer is disabled.

c. Display the Color Bar with the 2FLD SWEEP. Connect the output of a 60-Hz sine wave generator to the opposite side of the CH-B LOOP-THRU with a 10X, 75  $\Omega$  attenuator. Disable the DC Restorer. Adjust the amplitude of the sine wave to displace the sync tips by 50 IRE p-p. Select the DC Restorer. See Fig. 5-3.

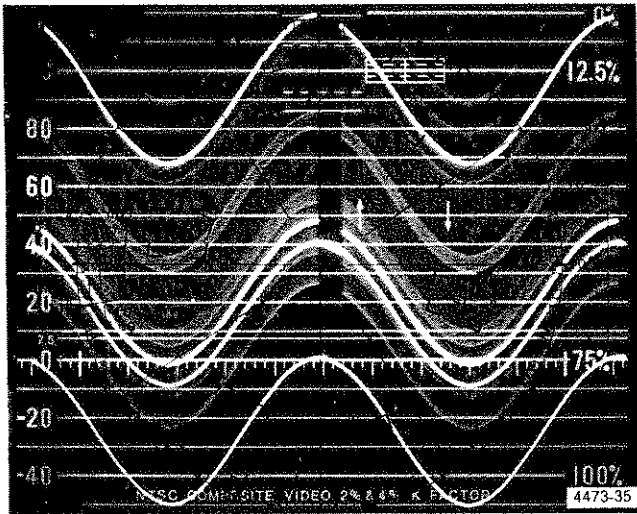

Fig. 5-3. DC Restorer 60 Hz hum response.

d. CHECK—that the p-p displacement of the sync tips is greater than 40 IRE.

e. Remove the sine wave source and terminate. Display the Color Bar with the 2H SWEEP. Select DC Restoration.

f. CHECK—that the blanking level of the signal moves less than 1 IRE (7 mV) ( $\pm 1\%$  of the standard video amplitude from blanking to 100% peak white), as the generator Burst is turned on and off.

g. Display the Modulated Staircase with the 2H SWEEP. Select DC Restoration.

h. CHECK—that the blanking level changes less than 1 IRE (7 mV) ( $\pm 1\%$  of the standard video amplitude from blanking to 100% peak white), as the generator is changed from 10 and 90% APL.

## 11. Check Flat Response

REQUIREMENT—Flat response of the Waveform Mode (WFM) with 50 kHz as a reference; (within 2%), 50 kHz to 6 MHz, and (within +2% and -5%), 6 MHz to 8 MHz.

a. Connect the swept sine wave generator signal output to the CH-B INPUT. Connect the output of the generator's Z Blank TTL to the 1750-Series Remote Sync Input (J205, pin 8) and ground pin 10. Select 1750-Series INPUT B, 2FLD SWEEP, WFM Mode, and DC REST Off.

### 1750-Series Instrument Setup

INPUT	SIGNAL
CH-B	Sweeper 75 $\Omega$ output
REMOTE (pin 8)	Z Blank TTL on rear panel
REMOTE (pin 10)	Grounded (REMOTE pin 1)

### HP3336C Sine-Wave Generator Setup

OUTPUT	75 $\Omega$
SWEEP	DATA
Cont	
Start Freq	50 kHz
Stop Freq	8 MHz
Time	0.034 sec (1750) 0.040 sec (1751)
Amplitude	approx. -0.70 dBm (-0.80 dBm for the 1751) Fast Leveling

b. CHECK—the flat response in X1 GAIN using the 50-kHz response as a reference. Check that the response is within  $\pm 2\%$  from 50 kHz to 6 MHz, and within +2% and -5% from 6 MHz to 8 MHz.

c. Select X5 GAIN. Set the generator amplitude to approximately -14.7 dBm (-14.8 dBm for the 1751). Use the modify function as needed to adjust the amplitude.

d. CHECK—the flat response in X5 GAIN. Use the specification listed in part b.

## 12. Check Transient Response

REQUIREMENT—Transient response for the 2T pulse and 2T bar: preshoot 1% or less. Pulse-to-Bar ratio: 1:1 within 1%. Overshoot: 2% or less. Ringing: 2% or less. Tilt: 1% or less for Field Rate square wave or 25  $\mu$ s bar. Variation of the 12.5T Modulated Pulse (20T for the 1751) base line (Overscan), less than 2% as the display is positioned over the middle 80% of the display (with ac coupled inputs).

## Checks and Adjustments—1750-Series

a. Connect the Pulse and Bar signal to the CH-B INPUT. Select the Full Amplitude 2T Pulse and Bar signals from the generator.

Display the signal with the 1H sweep.

b. CHECK—for less than 1% preshoot and less than 2% overshoot and ringing for the Pulse and Bar transitions.

c. CHECK—for a Pulse-to-Bar ratio within 1% of unity.

d. CHECK—for less than 1% tilt across the Bar.

e. Select the Field Square Wave signal. Display the signal with the 1FLD sweep.

f. CHECK—less than 1% tilt across the high APL portion of the display.

g. Insert 14 dB of attenuation in the input signal path. Select X5 GAIN.

h. CHECK—that the specifications of parts b through f are met with X5 GAIN.

i. Display the 12.5T Modulated Pulse from the Pulse and Bar generator with INPUT B (20T for the 1751). Check that the inputs are ac coupled (P403 and P207 must be in the lower, ac position). Position the baseline over the center 140 IRE (1 V for the 1751). See Fig. 5-4.

j. CHECK—that the baseline of the modulated pulse is within 2% of the signal blanking level for the conditions of part c.

### 13. Check the IRE or LUM Filter Response

**REQUIREMENT (1750)**—IRE response per IEEE Standard 205. Response at 15 kHz does not vary between FLAT and IRE by more than 1%.

**REQUIREMENT (1751)**—LUM response for the 1751: less than 3 dB attenuation at 1 MHz, and greater than 40 dB attenuation at 4.43 MHz. Response at 15 kHz does not vary between FLAT and LUM by more than 1%.

a. Connect the sine wave generator to the 1750-Series CH-B INPUT. Select: single frequency operation at the frequencies listed in the check steps below, and the amplitude as in step 11a. Make the measurements with respect to a 100% reference amplitude at 15 kHz. Select the IRE Filter of the 1750, or the LUM for the 1751.

b. CHECK—the 1750 for the IRE response listed below:

94 to 97.5% at 0.35 MHz

70 to 80% at 1 MHz

31.2 to 42.5% at 2 MHz

5.6 to 14% at 3.6 MHz

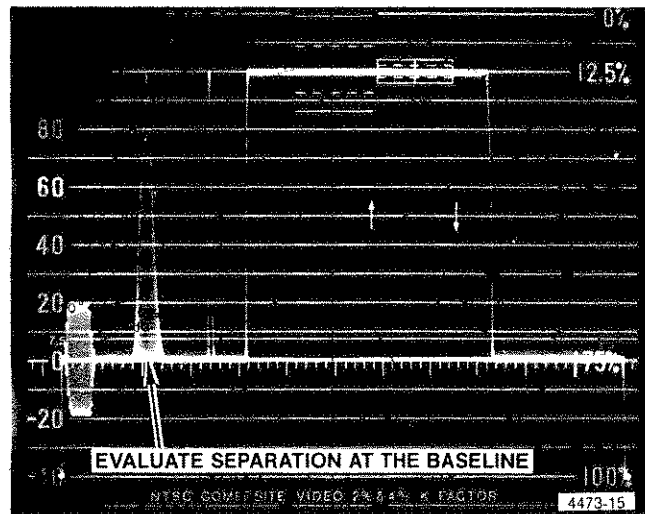

Fig. 5-4. Checking Modulated Sine-Squared pulse response.

c. CHECK—the 1751 for the LUM response listed below.

70 to 100% at 1 MHz

0 to 1% at 4.43 MHz

d. Connect the modulated 5 step Linearity signal to the B INPUT. Select the 100 IRE (100%) FLAT FIELD/ALT LINEARITY setting of the generator. Select the IRE Filter display of the 1750 (LUM Filter for the 1751).

e. CHECK—that the amplitude of the Linearity signal is within  $\pm 1\%$  of the amplitude of the display in the FLAT mode.

### 14. Check the CHROMA Filter Response

**REQUIREMENT**—Lower  $-3$  dB point 2.88 MHz  $\pm 0.1$  MHz (3.73 MHz  $\pm 0.15$  MHz for the 1751). Upper

−3 dB point 4.28 MHz  $\pm$  0.1 MHz (5.13 MHz  $\pm$  0.1 MHz for the 1751). Response at 3.58 MHz (4.43 MHz for the 1751) does not vary between FLAT and CHROMA by more than 1%. Attenuation at 7.2 MHz (8.9 MHz for the 1751): greater than 25 dB.

a. Connect the Color Bar signal to the CH-B INPUT. Turn the Luminance (Y) portion of the signal off. Unlock the SCH phasing of the generator.

b. Display the signal in FLAT with the 2H sweep. Use the Variable GAIN control to adjust the amplitude of the largest Chroma packet to be the amplitude from blanking to 100% peak white. Select the CHROMA Filter.

c. CHECK—that the amplitude of the largest Chrominance Bar is 99 to 101% of the amplitude in part b.

d. Connect the sine wave generator to the CH-B INPUT and set the generator output frequency to the system subcarrier frequency. Adjust the generator sine wave to be the amplitude from blanking to 100% peak white. Set the frequency of the sine wave generator above and below the system subcarrier frequency to the frequency that decreases the display amplitude to 70% of the reference amplitude.

e. CHECK—the −3 dB frequency response of the CHROMA Filter to be within the frequencies: (1750—2.78 to 2.98 MHz and 4.18 to 4.38 MHz), (1751—3.58 to 3.88 MHz and 5.03 to 5.23 MHz).

f. Set the frequency of the sine wave generator to 7.2 MHz (8.9 MHz for the 1751).

g. CHECK—that less than 5.6% of the reference amplitude remains.

## DEMODULATOR (Assembly A5)

### 15. Check Demodulator Channel Bandwidth

REQUIREMENT—Upper −3 dB point:  $F_{sc} + (400 \text{ kHz to } 600 \text{ kHz})$ . Lower −3 dB point:  $F_{sc} - (400 \text{ kHz to } 600 \text{ kHz})$ .

a. Connect the sine wave generator to the CH-B INPUT. Display the system subcarrier in Vector Mode. Adjust the amplitude of the sine wave so that the circle overlays the Vector Graticule Circle. Vary the frequency of the generator

so that the diameter of the circle at the vertical and horizontal axes is reduced to the 70% diameter at the small gaps in the horizontal and vertical axes. Refer to the Vector Graticule explanation and picture found in Section 2.

b. CHECK—that the frequency of the generator at the frequencies above and below the subcarrier frequency are within the range of 3.98 to 4.18 MHz and 2.98 to 3.18 MHz (4.83 to 5.03 MHz and 3.83 to 4.03 MHz for the 1751).

### 16. Check Color Bar Decoding Accuracy

REQUIREMENT—Vector Phase accuracy within  $\pm 1.25^\circ$ . Vector Gain accuracy within  $\pm 1.25 \text{ IRE}$  ( $\pm 2.5\%$  for the 1751).

a. Connect the Color Bar to the CH-B INPUT. Display the signal in Vector Mode (PAL Vector Mode for the 1751) and adjust the PHASE control to place the vector dots into their vector boxes.

b. CHECK—that all of the vectors fall within  $\pm 1.25^\circ$  and  $\pm 1.25 \text{ IRE}$  ( $\pm 1.25^\circ$  and  $\pm 2.5\%$  for the 1751) of the center of the boxes. These specifications represent 1/2 the dimension from the center cross of a vector box to the edge of the small inner box.

c. For the 1751 select the +V Vector Mode.

d. CHECK—that the Burst vectors can be overlaid with the PHASE control.

### 17. Check Subcarrier Regenerator Performance

REQUIREMENT—Pull in range:  $F_{sc} \pm 50 \text{ Hz}$  ( $\pm 10 \text{ Hz}$  for the 1751). Pull in time less than 1 second. Phase shift at these frequency offsets, less than  $0.5^\circ$ . Phase shift with  $\pm 6 \text{ dB}$  burst amplitude change, less than  $2^\circ$ .

a. Connect the Color Bar signal to the CH-B INPUT. Display the signal in Vector Mode.

b. At the generator change the subcarrier frequency by  $\pm 50 \text{ Hz}$  ( $\pm 10 \text{ Hz}$  for the 1751).

c. CHECK—that the 1750-Series instrument locks to the generator within 1 second at these frequencies.

d. CHECK—that the 1750-Series instrument display does not change by more than  $\pm 0.5^\circ$  at these frequencies.

## Checks and Adjustments—1750-Series

e. At the generator vary the Burst Amplitude within  $\pm 6$  dB of the calibrated amplitude.

f. CHECK—that the 1750-Series instrument display does not change by more than  $\pm 2^\circ$  within these amplitudes.

### 18. Check Phase Accuracy

REQUIREMENT—Phase shift with signal input channel change or reference channel input change: less than  $0.5^\circ$ . Phase shift with X5 GAIN selected less than  $2^\circ$ . Phase shift with +3 to -6 dB VAR GAIN change: less than  $1^\circ$ . Burst jitter: less than  $0.5^\circ$ .

a. See Fig. 5-5. Connect the Color Bar through a  $75\ \Omega$  coaxial cable, a  $75\ \Omega$  feedthrough terminator, and a dual input coupler to the CH-A INPUT and CH-B INPUT. Connect the Black Burst signal to the EXT REF LOOP-THRU. Select EXT REF. Display the Color Bars of INPUTs A and B alternately with the VECTOR display.

b. CHECK—that the phase match of CH-A INPUT to CH-B INPUT is within  $\pm 0.5^\circ$ .

c. Remove the Black Burst signal from the EXT REF INPUT. Move the connection at the CH-A INPUT to the EXT REF INPUT. Alternately display INPUT B with Internal and EXTERNAL REFERENCES.

d. CHECK—that the phase of the display when EXT REF is selected is within  $\pm 0.5^\circ$  of the phase from the Internal

Reference. Remove the dual input coupler and the feedthrough terminator and reterminate the far side of the loop-thru.

e. CHECK—that there is less than  $0.5^\circ$  burst jitter in Internal or EXT REF.

f. At the generator select the Linearity Staircase signal with 40 IRE subcarrier (280 mV in PAL). Display the signal in Vector Mode. Set the Staircase vector dot to the left horizontal graticule line with the PHASE control. Select X5 GAIN and R-Y display mode (V-Axis for the 1751).

g. CHECK—that the demodulated staircase subcarrier line is within  $2^\circ$  of the 0 mark on the right-hand differential phase scale.

h. Use the signal and setup of part f, but leave the controls in VECTOR and X1 GAIN. Note the amplitude of the staircase subcarrier vector. Set the VARIABLE GAIN control to maximum (+3 dB) and to the point that the vector has been decreased to one half of the vector length in the detented position (-6 dB).

i. CHECK—that the phase change is less than  $1^\circ$  over this range.

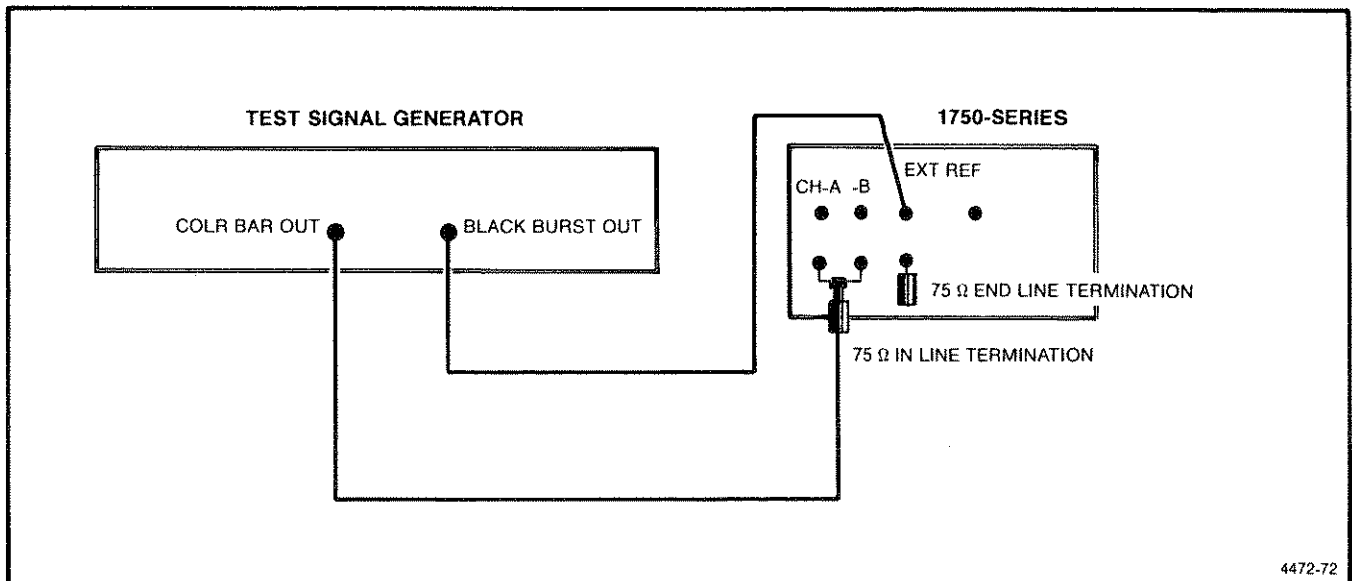

Fig. 5-5. Driving both CH-A and CH-B INPUTs with Color Bar signal.

**19. Check Amplifier Linearity**

REQUIREMENT—Differential Phase: less than  $1^\circ$  for a 10 to 90% APL Linearity Staircase. Differential Gain: less than 1% for a 10 to 90% APL Linearity Staircase.

a. Display the Modulated Staircase in Vector Mode. Check that the vector dot representing the subcarrier on the staircase is at the Burst cross on the horizontal axis (use the small dot on the —U axis for the 1751). Select X5 GAIN, R—Y Mode, and the 2H SWEEP (V-Axis Mode for the 1751).

b. CHECK—that there is less than  $1^\circ$  of differential phase between the steps with the greatest difference. Use the R—Y or V-Axis scale to the right of the Vector Graticule Circle for phase evaluation.

c. Display the Modulated Staircase with the Waveform Mode (WFM) and select the CHROMA Filter. Select X5 GAIN and use the Variable GAIN control to adjust the largest amplitude chrominance step to be the amplitude from blanking to 100% peak white. Select 10 and 90% average picture levels. Readjust the amplitude of the largest amplitude chrominance step if necessary.

d. CHECK—that the smallest amplitude chrominance step is greater than 99% of the reference amplitude at both average picture levels.

**20. Check Chrominance Vector Clamp Performance**

REQUIREMENT—Clamp stability:  $1/64''$  (0.4 mm) or less center dot movement as the PHASE control is rotated throughout its range. Position Control range: at least  $1/4''$  (6 mm) from the center at either limit.

a. Connect the Color Bar signal to the CH-B INPUT. Display the signal with the Vector Mode. Rotate the PHASE control throughout its range.

b. CHECK—that the center dot of the vector display moves less than  $1/64''$  (0.4 mm) as the PHASE control is rotated (approximately the line width of the Vector Graticule center cross).

c. Vary the VECTOR POSITION controls throughout their range. Return the vector display to the centered position.

d. CHECK—that the range of each control is greater than  $\pm 1/4''$  (6 mm) from the centered position.

**21. Check X5 GAIN and VARIABLE GAIN in Vector Mode**

REQUIREMENT—Input subcarrier signals between 28 IRE and 140 IRE (0.200 and 1.0 V for the 1751) can be adjusted to the burst amplitude. With X5 GAIN selected, input subcarrier signals between 6 IRE and 28 IRE (0.042 and 0.200 V for the 1751) can be adjusted to the burst amplitude.

a. Connect the Black Burst signal to the EXT REF input. Connect the Subcarrier output from the video signal generator through the Step Attenuator to the CH-B INPUT.

b. Display the sine wave with the 2H SWEEP in Waveform Mode (WFM) with EXT REF synchronization. Adjust the Step Attenuator so that the sine wave display is 1 V p-p. Select the VECTOR display and position the vector to the burst axis.

c. Add 0 dB and 14 dB to the Step Attenuator setting.

d. CHECK—that the vector dot can be set to the Burst amplitude mark on the vector graticule with the VARIABLE GAIN control.

e. Select X5 GAIN. Add 14 dB and 28 dB to the Step Attenuator setting of part a.

f. CHECK—that the vector dot can be set to the Burst amplitude mark on the vector graticule with the VARIABLE GAIN control.

**22. Check INPUT and PIX MON OUT Return Loss**

REQUIREMENT—Return loss for each input: at least 40 dB from 50 kHz to 6 MHz (instrument on or off, input in use or not, for any deflection factor setting). Return loss of the PIX MON OUT: at least 30 dB (50 kHz to 6 MHz) with the instrument on.

a. Connect the sine wave generator to the input of the Return Loss Bridge. Set the generator to sweep from 50 kHz to 6 MHz. Connect the output of the Bridge to the oscilloscope and set the amplitude of the display to 500 mV p-p with the terminator removed from the measurement arm

## Checks and Adjustments—1750-Series

of the Bridge. Reconnect the terminator and balance the Bridge. Connect the measurement arm of the Bridge to the INPUT of the 1750-Series instrument and the terminator to the opposite side of the LOOP-THRU. Refer to steps 5a, 5f, and 11a for the sine wave generator control set up.

b. CHECK—that the return loss of each input is better than 40 dB. Make this check (within this frequency range) with the instrument power on and off.

c. Connect the measurement arm of the Bridge to the PIX MON OUT connector and the terminator to the opposite side of the LOOP-THRU. Check that there are no inputs to the 1750-Series instrument.

d. CHECK—that the return loss of the PIX MON OUT is better than 30 dB. This measurement is made with instrument power on, and with no signal output.

### SCH LOGIC (Assembly A9)

#### 23. Check Acquisition Time and Accuracy

REQUIREMENT—Lockup in 1 second or less with a display error of  $\pm 5^\circ$  or less. This check requires that the SCH phase of the input signal be known.

a. Connect the Black Burst signal from the 1410 (1411) Mod AA to the test scope vertical input. Set the timebase for a 10 ns/div sweep.

b. Apply Color Bar signal from the 1410 (1411) to the 1750-Series CH-A INPUT. Set for internal reference.

In addition, for the 1751 only; set the LINE SELECTOR to line 14, and trigger the test scope from TP609 on the SCH Logic board. Use delaying sweep.

c. Calibrate the 1410-Series Mod AA SCH phase.

d. Select 1750-Series SCH Mode and use the PHASE control to place the burst vector(s) on the axis (axes).

e. CHECK—that the sync (outer dot) is within  $5^\circ$  of the B-Y (-U) axis.

#### 24. Check Display Range

REQUIREMENT—At least  $80^\circ$  of range either side of the B-Y (U) axis.

a. Apply the SCH phase calibrated Black Burst signal to the CH-A INPUT.

b. Use the 1750-Series PHASE control to place the burst vector(s) on axis.

c. Rotate the 1410 (1411) Horiz Delay so that the sync dot travels  $90^\circ$  either side of the B-Y (U) axis.

d. CHECK—that the display remains stable, with the sync dot traveling at least  $80^\circ$  before the sync dot switches by  $180^\circ$ . There should be an area, which includes  $90^\circ$ , where the display becomes unstable.

#### 25. Check Channel and Reference Match

REQUIREMENT—That the error between display channels and between internal and external references be  $0.5^\circ$  or less.

a. Loop-through connect the 1410 (1411) signal through both CH-A and CH-B INPUTs to the EXT REF and terminate in  $75 \Omega$ .

b. Select 1750-Series A INPUT and use the PHASE control to place the burst vector(s) on axis.

c. Note the position of the sync dot.

d. Select the B INPUT and adjust the PHASE control to place the burst vector(s) on axis.

e. CHECK—that the sync dot is within  $0.5^\circ$  of the position noted in part c.

f. Push EXT REF and adjust the PHASE control to place the burst vector(s) on axis.

g. CHECK—that the sync dot is within  $0.5^\circ$  of the position noted in part e.

# ADJUSTMENT PROCEDURE

## SHORT-FORM PROCEDURE

### POWER SUPPLIES AND CRT ALIGNMENT (Assemblies A1 and A6)

#### 1. Preliminary Setup

- Connect ac power.
- Set autotransformer for correct line voltage and turn on 1750-Series.
- Connect television signal source.

#### 2. Check Low Voltage Supply Regulation

- Vary autotransformer.
- Check ripple at J694, pin 4.

#### 3. Adjust 12 V Supply

- Connect voltmeter.
- Adjust 12 V Adj. (A6-R205).

#### 4. Adjust HV

- HV probe to A1-TP830.
- Adjust HV Adj. (A1-R738).

#### 5. CRT Bias Adjustments

- No video signal displayed.
- Set INTENSITY control to minimum.
- Set INTENSITY control for 5 V from minimum.
- Adjust CRT Bias (A1-R512).
- Midrange FOCUS control.
- Select 2H SWEEP, WFM Mode.
- Set INTENSITY control clockwise.
- Adjust Intens Limit (A1-R554).
- Apply Color Bar Signal.
- Adjust Focus Centering (A1-533) and Astig. (A1-551).

#### 6. CRT Alignment Adjustments

- No input video signal.
- Adjust Trace Rotation (A6-R106).
- Display 2F, 5X Mag., Color Bar signal.
- Adjust Y Align (A6-R101) and Geom (A1-R514).

### HORIZONTAL BOARD (Assembly A4)

#### 7. Adjust IC Voltage Regulators

- Adjust +12 V Adj (A4-R445).
- Adjust -12 V Adj (A4-R650)

#### 8. Sweep Calibration

- Apply a sine wave.
- Mid range SWEEP CAL and select CAL INPUT.
- Adjust 10  $\mu$ s/Div Gain (A4-R191).
- Display sine wave at 2H, MAG.
- Adjust 1  $\mu$ s/Div Gain (A4-R297).
- Check 1H, MAG accuracy.
- Display Color Bar signal at 2H, Mag.
- Adjust Mag Register (A4-R180).
- Change sine wave frequency.
- Display 1H, MAG.
- Adjust 0.2  $\mu$ s/Div Gain (A4-R296).
- Check HORIZ POS range.

#### 9. RGB/YRGB Parade Display

- Display Color Bar signal at 1H.
- Connect test connector to remote connector.
- Adjust RGB Centering (A4-R471).
- Check HORIZ POS range.
- Connect 2-kHz square wave.
- Adjust RGB Compensation (A4-C373).

#### 10. Sync Width

- Apply Color Bar signal.
- Adjust Sync Width 1 (A4-R110).
- Change test oscilloscope probe.
- Adjust Sync Width 2 (A4-R125).

### VERTICAL BOARD (Assembly A3)

#### 11. Adjust IC Voltage Regulators

- Check +12 V supply.
- Adjust -12 V Adj (A3-R535).



## 12. Adjust Vertical Gains

- a. Apply Video Amplitude Calibrator (VAC) signal.
- b. Switch back and forth between VAC and 1750-Series CAL.
- c. Adjust Cal Ampl (A3-R532).
- d. Select FLAT filter.
- e. Adjust Gain 1 (A3-R664).
- f. Adjust Gain 2 (A3-R176).
- g. Remove input signal.
- h. Adjust Variable Balance (A3-R562).
- i. Apply VAC signal to CH-A INPUT.
- j. Adjust CH-A Gain (A3-R113).
- k. Remove signal. Switch back and forth between CH-A and CH-B.
- l. Adjust Channel A Offset (A3-R129).
- m. Remove input signal and VERTICAL POSITION fully cw, and select 5X GAIN.
- n. Adjust Output Bias (A3-R191).
- o. Trace on 0 IRE (300 mV) line, normal vertical gain.
- p. Adjust Mag Registration (A3-R274).

## 13. Flat Response Adjustment

- a. Connect sine wave generator.
- b. Adjust flat response;  
Channel B

Ch B Resp (A3-C320) - FR 1 (A3-C378)  
FR 2 (A3-C370) - FR 3 (A3-C288)  
FR 4 (A3-R182)

Channel B X5 GAIN  
X5 Resp (A3-C280)

## 14. Adjust IRE Filter (LUM Filter for the 1751)

- a. Apply 5-step linearity signal.
- b. Adjust LPF Resp (A3-L550).
- c. Adjust LPF Gain (A3-R560).

## 15. Adjust CHROMA Filter

- a. Apply Color Bar signal.
- b. Adjust Chroma Filter response BPF2 (A3-C455) and BPF1 (A3-C456).

## 16. Adjust CH-A to CH-B Match

- a. Apply Color Bar signal to CH-A and CH-B INPUT.
- b. Select Vector Mode and INPUT B.
- c. Adjust CH-A Resp. (A3-C111)

## 17. Adjust Internal to EXTERNAL REFERENCE Match

- a. Apply Color Bar Signal to CH B INPUT and EXT REF INPUT.
- b. Select Vector Mode and INPUT B.
- c. Adjust Ext. Phase (A3-C709).

## DEMODULATOR (Assembly A5)

### 18. Adjust IC Voltage Regulators

- a. Adjust +12 V Adj (A5-R186).
- b. Adjust -12 V Adj (A5-R192).

### 19. Adjust Output Amplifier Gain Match

- a. Apply Color Bar signal, select VECTOR, and move A5-P801.
- b. Adjust B-Y (U) Gain (A4-R845).
- c. Replace A5-P801.
- d. Set VECTOR VERT POS and VECTOR HORIZ POS.

### 20. Adjust Demodulation Gains and Quad Phase

- a. Check that vector unlocks in EXT REF with no reference applied.
- b. Adjust R-Y (V) Gain (A5-R116), B-Y (U) Gain (A5-R518), and Quad Phase (A5-L132).

(Alternate method of Setting Quad Phase (L132))

#### 1750 NTSC

- a. Apply sine wave and move (A5-P532).
- b. Adjust Quad Phase (A5-L132).
- c. Return A5-P532 to original position.

#### 1751 PAL

- a. Apply Color Bar signal, display VECTOR, and press +V/PAL.
- b. Overlay vectors with PHASE control and Adjust Quad Phase (A5-L132).

### 21. Adjust Subcarrier Phase Lock Circuit

- a. Disconnect any input signal.
- b. Move A5-P159.
- c. Adjust High Frequency Limit (A5-R167).
- d. Move A5-P159.
- e. Adjust Low Frequency Limit (A5-R170).
- f. Return A5-P159.
- g. With burst vector on horizontal axis change burst amplitude + and - 6 dB from normal.
- h. Adjust Phase Balance (A5-R173).

### 22. Adjust Phase Match

- a. Apply Color Bar signal, use black burst as ext. reference.
- b. Adjust CH-A Phase (C116).
- c. Use Color Bar signal as ext. reference.
- d. Adjust Ext Phase (A3-C709).

**23. Adjust SCH VCOs**

- a. Apply Color Bar signal. Select SCH Mode.
- b. Test scope to A9-TP898.
- c. Adjust VCO1 (A9-C694).
- d. Test scope to A9-TP760.
- e. Adjust VCO2 (A9-C852).

**24. Adjust SCH Balance**

- a. Apply Color Bar signal.
- b. Test scope probes both to A4-TP110.
- c. Move one test scope probe to A4-TP108.
- d. Adjust SCH Bal (A4-R110).

**25. Adjust SCH Display Amplitude**

- a. Select SCH Mode.
- b. Check center dot position.
- c. Adjust SCH Amp. (A9-R130).

**26. Adjust SCH Phase Calibration**

- a. Black burst to test scope.
- b. Color Bar to 1750-Series.
- c. Calibrate 1410-Series SCH Phase.
- d. Position burst vector(s) in Vector Mode.
- e. Select SCH Mode.
- f. Adjust SCH1 (A4-R136).
- g. Adjust REPhase Trip Point (A5-R180).
- h. Adjust SCH2 (A4-R141).
- i. Repeat parts c through e (f through h, if necessary).

**DETAILED ADJUSTMENT PROCEDURE**

Any maintenance should be performed before proceeding with calibration. Problems encountered during calibration should also be corrected before proceeding.

The following procedure uses items from the Recommended Test Equipment list at the beginning of this section. If equipment is substituted, control settings or setups may need to be altered.

**1750-Series Setup**

After a numbered step has been completed, return the 1750-Series controls to the standard conditions in the table below, unless otherwise noted.

POWER	ON
INTENSITY	As desired.
FOCUS	
SCALE	
VERT POS	
HORIZ POS	
Push Buttons Depressed	
WFM	
2H	
FLAT	
INPUT B	
Variable GAIN	CAL
CH-A INPUT (rear panel)	HI Z

**POWER SUPPLIES AND CRT ALIGNMENT  
(Assemblies A1 and A6)**

**1. Preliminary setup**

a. Connect the variable autotransformer to the AC power connector.

b. Turn on the autotransformer and set it for the nominal line voltage selected by the Line Voltage Selector on the rear panel of the 1750-Series instrument.

c. Connect the television signal source to the CH-B INPUT and a 75 Ω terminator to the opposite side of the loop-thru. Select the composite Color Bar signal output with 100% White Bar and 75% Amplitude Color Bars.

**2. Check Power Supply Regulation**

REQUIREMENT—Power Supply remains in regulation over the specified line voltage operating range. See rear-panel Line Voltage Selector for correct operating line voltage.

a. Vary the autotransformer from low line to high line voltage (as determined by the line voltage selector on the rear panel).

## Checks and Adjustments—1750-Series

b. CHECK—that the instrument continues to operate and that the ripple voltage at pin 4 of J694 is less than 30 mV over this range.

### 3. Adjust +12 Volt Supply

REQUIREMENT—+12 V  $\pm$ 1% at pin 6 of J694.

a. Connect the voltmeter to J694, pin 6.

#### NOTE

*Adjusting the +12 Volt supply affects some gain settings. It should not be adjusted if operation appears normal and voltage is near 12 volts.*

b. ADJUST—12 V Adj. (R205) on the LV Power Supply circuit board (A6).

### 4. Adjust HV

REQUIREMENT— -3000 volts  $\pm$ 2% at TP830.

a. Connect voltmeter HV probe to TP830 on the Interface and HV Power Supply circuit board (A1).

#### NOTE

*Adjusting the HV affects all display gains. It should not be reset unless all other gains are to be readjusted.*

b. ADJUST—HV Adj. (R738) for -3000 V  $\pm$ 60 V.

### 5. CRT Bias Adjustments

REQUIREMENT—The Intensity control voltage is set for CRT cutoff bias requirements and maximum focused brightness. Intensity Limit (R554) set for 20 V at TP558. The Focus and Astigmatism controls are set for best spot size.

a. Switch to INPUT A so that no signal is displayed.

b. Set the INTENSITY control to minimum.

c. While monitoring the voltage at TP527 on Assembly A1, with an oscilloscope, advance the INTENSITY control until the bottom of the square wave has increased 5 volts from its minimum.

d. ADJUST—Crt Bias (A1-R512) so that the CRT trace just disappears.

e. Set the FOCUS control to midrange.

f. Select 2H SWEEP, WFM Mode, be sure MAG and LINE SELECTOR are Off.

g. Connect test oscilloscope probe to A1-TP558 and turn 1750-Series INTENSITY fully clockwise.

h. ADJUST—Intens Limit (A1-R554) for 20 V as read on test oscilloscope.

i. Switch to INPUT B and display the Color Bar signal. Use the 2H SWEEP. Set the Intensity control for the desired brightness.

j. ADJUST—the display for best focus using the Focus Center (A6-R533) and Astig (A6-R551).

### 6. CRT Alignment Adjustments

REQUIREMENT—The horizontal trace is adjusted to be parallel to the graticule with the Trace Rotation control (R106). Vertical lines of the display are adjusted to be vertical and straight with Y Alignment (R101) on Assembly A6, and Geometry (R514) on Assembly A1.

a. Select INPUT A.

b. ADJUST—Trace Rotation (R106) on Assembly A6 so that the trace is parallel to the horizontal graticule lines.

c. Select INPUT B, 2FLD, and X5 GAIN.

d. ADJUST—Y Align (R101) on Assembly A6 so that a vertical line of the display is vertical, and Geom (R514) on Assembly A1 for straightness. Repeat parts a through d to remove interaction.

## HORIZONTAL BOARD AJUSTMENTS (Assembly A4)

### 7. Adjust IC Voltage Regulators

REQUIREMENT—The monolithic power supply regulators are adjusted; +12 V at TP171 with +12 V Adj. (R445), -12 V at TP175 with -12 V Adj. (R650) on Assembly A4.

a. ADJUST—the +12 V Adj. (R445) for +12 V  $\pm$ 0.12 V at TP171 on Assembly A4.

b. ADJUST—the -12 V Adj. (R650) for -12 V  $\pm$ 0.12 V at TP175 on Assembly A4.

### 8. Sweep Calibration

REQUIREMENT—The 2H and 2H magnified sweeps are set for 10  $\mu$ s/div (R191) and 1  $\mu$ s/div (R297) on Assembly A4. The 1H magnified sweep is set for 0.2  $\mu$ s/div (R296) on Assembly A4. The Sweep Mag Register (R180) is set to expand about the center so that the blanking interval of the 2H and 2FIELD sweeps will be visible when a centered sweep is magnified.

a. Connect the sine wave generator to the CH-B input of the 1750.

#### 1750-Series Instrument Setup

2H MAG	
CH-B	Sine Wave Generator
X5 GAIN	

#### HP3336C Setup

Sweep	Single
Data	1 MHz
Amplitude	0 dBm

b. Mid range the SWEEP CAL. Select the CALibrator INPUT.

c. ADJUST—the 10  $\mu$ s/div gain (R191) on Assembly A4 for 10  $\mu$ s/div. One Calibrator waveform cycle equals 10  $\mu$ sec.

d. Display INPUT B with the 2H MAG SWEEP. Position the sine wave tips to the horizontal division markings of the display. See Fig. 5-6.

e. ADJUST—the 1  $\mu$ s/div gain (R297) on Assembly A4 for 1  $\mu$ s/div.

f. CHECK—that in 1H MAG, the interval of 5 sine wave tips equals 9.6 to 10.4 major div.

g. Display the Color Bar signal with INPUT B and the 2H MAG SWEEP. Use the HORIZ POS to position the negative sync transition to the center graticule mark. Release the MAG button.

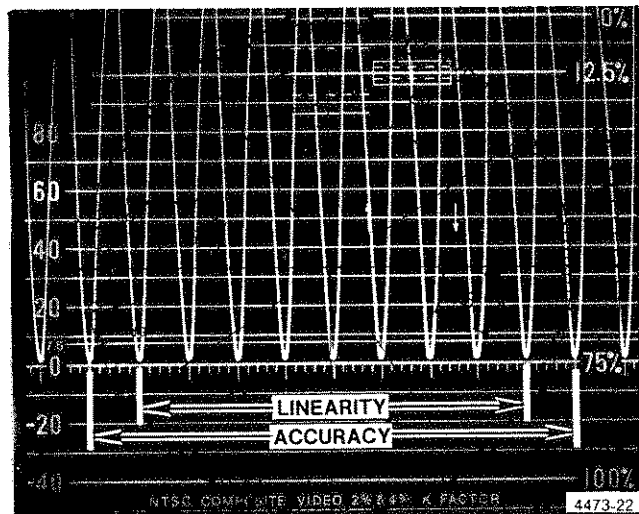

MEASURE TIMING ACCURACY  
BETWEEN CENTER 10 DIVISIONS

MEASURE TIMING LINEARITY  
BETWEEN CENTER 8 DIVISIONS

4472-67

Fig. 5-6. Using triggered sine waves to make timing measurements.

h. ADJUST—the negative sync transition to the center graticule mark with the Mag Register (R180) on Assembly A4. Repeat parts g and h as necessary to remove interaction.

i. Set the HP3336C Frequency to 5 MHz.

j. Set the 1750-Series SWEEP to 1H and press the MAG.

k. ADJUST—The 0.2  $\mu$ s/div Gain (R296) on Assembly A4 for 1 mark per major division.

l. CHECK—that the HORIZ POS has sufficient range to position any part of the sweep onto any part of the screen in the 2H MAG display.

### 9. RGB/YRGB Parade Display

REQUIREMENT—The parade display is adjusted for dc centering (R471) and for input compensation (C373) on Assembly A4. Check for sweep attenuation to; 1/3 or 1/4 of normal, and staircase input gain.

a. Display the Color Bar in 1H. Center the display. Note the position of P685 on Assembly A4 that selects 3 or 4 step parade display.

## Checks and Adjustments—1750-Series

b. Connect the test connector to the remote connector. Note that the sweep has shortened to 1/3 or 1/4 of its previous length (3.4 to 4.1 div. or 2.5 to 3.1 div. respectively), depending on the position of P685.

c. Set the display to the center of the screen with RGB Ctr. (R471) on Assembly A4.

d. CHECK—that the display can be moved to the sides of the screen with the HORIZ POS control.

e. Remove the Color Bar signal. Position the display to the right side of the screen. Connect a 0 to +10 V, 2 kHz square wave to the Parade Display test connector (item 19 of the Equipment list). Note that 8.6 to 10.4 divisions of deflection have been added by the square wave (e.g., from the start of one short sweep to the start of the other short sweep).

f. ADJUST—RGB Compensation (C373) on Assembly A4 for best transient response at TP580 as measured with the test oscilloscope.

### 10. Adjust Sync Width

REQUIREMENT—That sync width be set so that burst flag and burst coincide. R110 is Sync Width 1 and R125 is Sync Width 2.

a. Apply Color Bar signal, and set SWEEPS to 1H. Connect test oscilloscope to TP600 on Assembly A4.

b. ADJUST—R110 (Sync Width 1) so that the burst flag area (denoted by two notches) falls under burst.

c. Change test oscilloscope probe to TP222 on Assembly A4.

d. ADJUST—R125 (Sync Width 2) so that the burst flag area (denoted by two notches) falls under burst.

## VERTICAL BOARD ADJUSTMENT (Assembly A3)

### 11. Adjust IC Voltage Regulators

REQUIREMENT—The monolithic power supply regulators are adjusted; +12 V at TP139 with Cal Ampl (R532) (this supply is adjusted for the Calibrator display amplitude), -12 V at TP233 with -12 V Adj. (R535) both on Assembly A3.

a. CHECK—the +12 V supply at TP434 on Assembly A3. If the supply is close to +12 V do not change the setting of R532 as this supply is used to set the Calibrator amplitude.

b. ADJUST—R535 (-12 V Adj.) for  $-12\text{ V} \pm 0.12\text{ V}$  at TP233 on Assembly A3.

### 12. Adjust Vertical Gains

REQUIREMENT—The display amplitude is adjusted for 140 IRE (1 V for the 1751) with a 1-V square wave input. An intermediate amplitude is adjusted for 2 V p-p (TP379) with Gain 1 (R664), the display amplitude is set with Gain 2 (R176). INPUTs A and B are matched in gain with CH-A Gain (R113). The Calibrator display is adjusted to the same amplitude as the 1 V input with Cal Ampl (R532). Adjust Variable Gain Balance (R562) for no trace movement as the VARIABLE GAIN control is varied. Adjust CH-A Offset (R129) for no dc offset as the input switch is changed. Adjust the Mag Registration for expansion about the 0 IRE (0 V) line with R274. Adjust the Output Amplifier Bias (R191) for 1.5 V on the brown vertical deflection lead to the CRT with the VERTICAL POSITION control fully clockwise. All adjustments are on Assembly A3.

a. Connect the Video Amplitude Calibrator (VAC) to the CH-B INPUT. Set the VAC to 999.9 mV. Set WAVEFORM VERT CAL to midrange.

Select the IRE Filter (LUM Filter for the 1751).

b. Alternately switch between INPUT B and the CAL INPUT.

c. ADJUST—Cal Ampl (R532) on Assembly A3 to match the amplitude of the calibrator waveform with the amplitude of the VAC waveform.

d. Select the FLAT display.

e. ADJUST—Gain 1 (R664) on Assembly A3 for a 2-V p-p square wave at TP569 with the VAC input.

f. ADJUST—Gain 2 (R176) on Assembly A3 for a vertical amplitude of 140 IRE with the VAC input ( $-0.3$  to  $+0.7\text{ V}$  for the 1751).

g. Select INPUT B and remove the VAC from the CH-B INPUT. Make certain that the DC REST is not active. Set

the VERT POS control to place the trace on the 0 IRE (300 mV) line.

h. ADJUST—Variable Balance (R562) on Assembly A3 for no movement of the trace as the VARIABLE GAIN control is rotated throughout its range.

i. Connect the VAC to the CH-A INPUT. Set the VAC for a 999.9-mV square wave. Make certain that the CH-A INPUT is not terminated.

j. ADJUST—Ch A Gain (R113) on Assembly A3 to match the display in A with that in B.

k. Disconnect the VAC from the 1750. Alternately switch between INPUTs A and B.

l. ADJUST—Ch A Offset (R129) on Assembly A3 so that the displays for CH-A and CH-B are at the same vertical position.

m. Remove the input signal and turn the VERTICAL POSITION control fully clockwise. Connect one lead of the digital multimeter to the brown CRT deflection lead. Select X5 GAIN.

n. ADJUST—Output Bias (R191) on Assembly A3 for 1.5 Vdc at the brown deflection plate lead.

o. Position the display to the 0 IRE (300 mV) line. Release the X5 GAIN button.

p. ADJUST—MAG Registration (R274) on Assembly A3 to reposition the display to the 0 IRE (0 V) line. Repeat parts o and p as necessary to remove interaction.

### 13. Flat Response Adjustment

REQUIREMENT—With a reference of 50 kHz, adjust FLAT response (within  $\pm 2\%$ ) from 50 kHz to 6 MHz, and (within  $+2\%$  and  $-5\%$ ) from 6 MHz to 8 MHz.

a. Connect the swept sine wave generator signal output to the CH-B INPUT. Connect the output of the generator's Z Blank TTL to the 1750-Series Remote Sync Input (J205 pin 8) and ground pin 10. Select 1750-Series INPUT B, 2FLD SWEEP, WFM Mode, and DC REST Off.

### 1750-Series Instrument Setup

INPUT	SIGNAL
CH-B	Sweeper 75 $\Omega$ output
REMOTE (pin 8)	Z Blank TTL on rear panel
REMOTE (pin 10)	Grounded (REMOTE pin 1)

### HP3336C Sine Wave Generator Setup

OUTPUT	75 $\Omega$
SWEEP	DATA
Cont	
Start Freq	50 kHz
Stop Freq	8 MHz
Time	0.034 sec (1750) 0.040 sec (1751)
Amplitude	approx. $-0.70$ dBm ( $-0.80$ dBm for the 1751)
Fast Leveling	

b. ADJUST—for best flat response.

Using 50 kHz as a reference: (within  $\pm 2\%$ ) from 50 kHz to 6 MHz, and (within  $\pm 5\%$ ) from 6 MHz to 8 MHz.

The table below gives approximate regions of control for the adjustments.

Control Setting	Adjustments on Assembly A3	Region
INPUT B	C320 (CHB RESP)	above 1 MHz
	C368 (FR 1)	above 6 MHz
	C370 (FR 2)	above 1 MHz
	C288 (FR 3)	at 11 MHz
	R182 (FR 4)	at 11 MHz
INPUT B	C280 (X5 RESP)	above 4 MHz
X 5 GAIN		

### 14. Adjust IRE Filter (LUM Filter for the 1751)

REQUIREMENT—Adjust the filter for best transient response with LPF RESP (L550) and for the same gain as in FLAT response with LPF GAIN (R560) on Assembly A3.

a. Connect the modulated 5 step Linearity signal to the CH-B INPUT. Select the 100 IRE (100%) FLAT FIELD/ALT LINEARITY setting of the generator. Select the IRE Filter display of the 1750 (LUM Filter for the 1751).

b. ADJUST—LPF RESP (L550) on Assembly A3 for best transient response and least overshoot on the white bar

## Checks and Adjustments—1750-Series

transition. Also check that there is 5 to 14% Subcarrier remaining on the Linearity signal (less than 1% subcarrier remaining in the 1751). The X5 GAIN may be used to judge the amount of subcarrier.

c. ADJUST—LPF GAIN (R560) on Assembly A3 for the same amplitude of the white bar as in FLAT response.

### 15. Adjust CHROMA Filter

REQUIREMENT—Adjust BPF2 (C455) and BPF1 (C456) on Assembly A3 for best transient response at the Green to Magenta transition and for the same amplitude as in FLAT response.

a. Connect the Color Bar signal to the CH-B INPUT. Turn the Luminance (Y) portion of the signal off. Unlock the SCH phasing of the generator. Select the CHROMA Filter display and 1H SWEEP of the 1750.

b. ADJUST—Chroma Filter response BPF2 (C455) and BPF1 (C456) on Assembly A3 for least overshoot and best transient response at the Green to Magenta transition. Leave the capacitors set so that the CHROMA Filter has the same amplitude display as in FLAT response.

### 16. Adjust CH-A to CH-B Phase Match

REQUIREMENT—Adjust CH-A Resp (C111) for best match of CH-B.

a. Apply Color Bar signal, through the Dual Input Coupler, to both CH-A and CH-B INPUT connectors. Do not terminate.

b. Select Vector Mode and INPUT B. Adjust variable GAIN to place the tip of the burst vector at the compass rose.

c. ADJUST—CH-A Resp (A3-C111) to match burst vector lengths while switching between INPUT A and INPUT B.

### 17. Adjust Internal to External Reference Phase Match

REQUIREMENT—Adjust C709 External Phase to match internal phase as closely as possible.

a. Connect the Color Bar signal, through the Dual Input Coupler, to the EXT REF INPUT and the CH-B INPUT.

b. Select Vector Mode and INPUT B. Adjust the 1750-Series variable GAIN to place the vector tip on the compass rose.

c. ADJUST—External Phase compensation (A3-C709) for no movement of the burst vector when switching between internal and external reference (EXT REF switch).

## DEMODULATOR BOARD ADJUSTMENTS (Assembly A5)

### 18. Adjust IC Voltage Regulators

REQUIREMENT—The monolithic power supply regulators are adjusted; +12 V at TP176 with +12 V Adj. (R186), -12 V at TP180 with -12 V Adj. (R192) on Assembly A5.

a. ADJUST—the +12 V Adj. (R186) on Assembly A5 for +12 V,  $\pm 0.12$  V at TP176.

b. ADJUST—the -12 V Adj. (R192) on Assembly A5 for -12 V,  $\pm 0.12$  V at TP180.

### 19. Adjust Output Amplifier Gain Match

REQUIREMENT—Adjust B-Y Gain (R845) on Assembly A4 so that the vector gains of the vertical and horizontal inputs are equal.

a. Connect the Color Bar signal to the CH-B INPUT. Select the VECTOR display on the 1750-Series. Move Jumper P801 on Assembly A5 to the Test (1-2) position.

b. ADJUST—B-Y Gain (R845) on Assembly A4 so that the vector lies along a line parallel to the line from 135° to 315°. The Variable GAIN control may be used to move the outer dots to the outer circle of the graticule. The line will cross the vector circle at equal increments away from the 90° and 0° positions of the circle. See Fig. 5-7.

c. Replace P801 (Assembly A5) in the Normal (2-3) position.

d. Set the VECTOR VERT and HORIZ POS controls to place the center dot at the vector graticule center.

### 20. Adjust Demodulation Gains and Quad Phase

REQUIREMENT—Adjust Quad Phase (L132), R-Y Gain (R116), and B-Y Gain (R518) on Assembly A5 for Color Bar decoding accuracy.

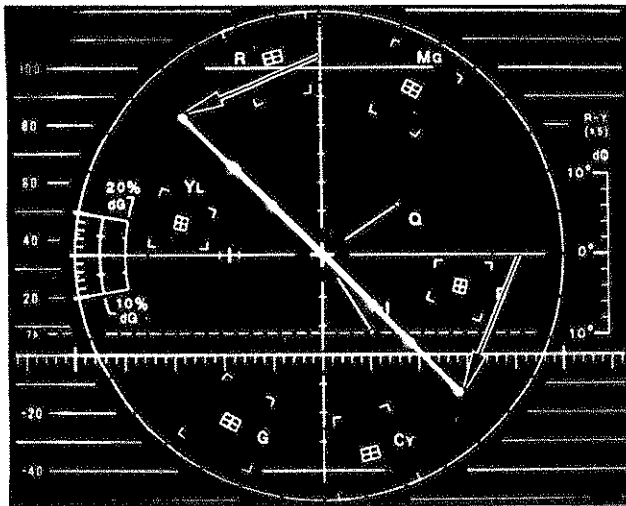

ADJUST FOR EQUAL DISTANCES

4472-70

Fig. 5-7. Adjusting B-Y (U) gain.

a. Select EXT REF with no signal connected to that input. Note that the vector display rotates.

b. ADJUST—R-Y (V) Gain (R116), B-Y (U) Gain (R518), and Quad Phase (L132), all on Assembly A5, so the outermost circle of the display is round and passes through the center of the Red and Cyan vector boxes.

**NOTE**

Since the Red Vector is very near the R-Y axis, its vector length is primarily controlled by the R-Y Gain. Once this control has been set the Variable GAIN can be used to place the outer circle of the display on the outer circle of the Vector Graticule. The Quad Phase control affects the roundness of the display at the axes that are 45° away from the horizontal and vertical axes. The B-Y Gain controls the horizontal gain of the display to complete the roundness of the circle. Recheck the gains in the Calibrated position of the Variable GAIN control.

**Alternate method of setting Quad Phase (L132)****NOTE**

This method for setting Quad Phase is more precise but requires the use of a sine wave generator for NTSC instruments. PAL instruments are adjusted using the PAL Color Bar signal.

**1750 (NTSC) Quad Phase Adjustment**

a. Connect the 75  $\Omega$  output of the HP3336C sine wave generator to the CH-B INPUT of the 1750. Move jumper P532 (the upper jumper of the pair, P532 and P534) on the Demodulator board Assembly A5 to the rear (P) position.

**1750 Setup**

VECTOR	
CH-B	Sine Wave Generator
EXT REF	

**HP3336C Setup**

Sweep	Single
Data	3.579545 MHz
Amplitude	-0.70 dBm

b. ADJUST—Quad Phase (L132) on Assembly A5 to overlay the two circles.

c. Return jumper P532 to the forward (N) position.

**1751 (PAL) QUAD PHASE ADJUSTMENT**

a. Connect the Color Bar signal to the CH-B INPUT. Display the Color Bar with the Vector Mode and with the +V/PAL button pressed.

b. Overlay the vectors with the PHASE control. Use the PHASE control to minimize the angular separation of the Vectors. Use the Quad Phase control (L132) on Assembly A5 to minimize the horizontal separation. There will be interaction between the two controls but the separation of all of the vectors can be minimized satisfactorily.

**21. Adjust Subcarrier Phase Lock Circuit**

REQUIREMENT—Adjust the Subcarrier Oscillator frequency control range for  $\pm 100$  Hz at TP134 on Assembly A5. With jumper P159 in the front horizontal (1-2) position, set HF Limit (R167) for subcarrier frequency +100 Hz. With jumper P157 in the rear (2-3) position set LF Limit (R170) for subcarrier frequency -100 Hz. Adjust Phase Balance (R173) for no phase change as the burst amplitude is varied  $\pm 6$  dB from the calibrated amplitude. Resistor R556 may be selected to improve phase balance.

a. Disconnect the signals from the 1750-Series instrument. Connect a X1 oscilloscope probe to the Frequency Counter and to TP134 on Assembly A5. Set the triggering of the Frequency Counter so that it indicates the system subcarrier frequency.



## Checks and Adjustments—1750-Series

b. Move jumper P159 on Assembly A5 to the front, horizontal (1-2) position (High Frequency Limit).

c. ADJUST—High Frequency Limit (R167) on Assembly A5 so that the Frequency Counter indicates the frequency is 100 Hz above the system subcarrier frequency.

d. Move jumper P159 to the rear, horizontal (2-3) position (Low Frequency Limit).

e. ADJUST—Low Frequency Limit (R170) on Assembly A5 so that the Frequency Counter indicates the frequency is 100 Hz below the system subcarrier frequency.

f. Return the jumper P159 to the vertical (2-4) position. The display should phase lock. Remove the oscilloscope probe from the instrument.

g. Position the Burst Vector to the horizontal axis. Using the generator's Burst Variable Amplitude control or an attenuator, change the amplitude of the vector from +6 dB to -6 dB of normal amplitude.

h. ADJUST—Phase Balance (R173) on Assembly A5 so that the Burst is held to the same phase throughout the range of part g. If it is not possible to reduce the phase shift to less than  $2^\circ$ , R556 may be selected from a range of 900 to 2000  $\Omega$ . Resistor R556 is selected to make the waveforms at the collectors of Q456 and Q457 symmetrical. Selection of resistor R556 is explained in Section 6, Maintenance.

## 22. Adjust Phase Match

REQUIREMENT—Using the phase of INPUT B as the reference, adjust the phase of the other inputs to match B: INPUTs A to B with an external reference, Ch A Phase (C116) on Assembly A3, INPUT B to the EXTernal REFerence, Ext Phase (C709) on Assembly A3.

a. See Fig. 5-8. Connect the Color Bar through a 75  $\Omega$  coaxial cable, a 75  $\Omega$  feedthrough terminator, and a dual input coupler to INPUTs A and B. Connect the Black Burst to the EXT REF INPUT. Display INPUTs A and B alternately with the VECTOR display and EXT REF.

b. ADJUST—Ch A Phase (C116) on Assembly A3 to return the vector dots to their boxes.

c. Remove the signal at the EXT REF INPUT. Move the connection at the CH-A INPUT to the EXT REF INPUT. Alternately display INPUT B with Internal and EXTernal REFERENCES.

d. ADJUST—Ext Phase (C709) on Assembly A3 to return the vector dots to their boxes.

## SCH LOGIC BOARD ADJUSTMENTS (Assembly A9)

## 23. Adjust SCH VCOs

REQUIREMENT—VCO levels are set at TP898, with C694 for VCO1 and at TP760, with C852 for VCO2. VCO levels are -7 V.

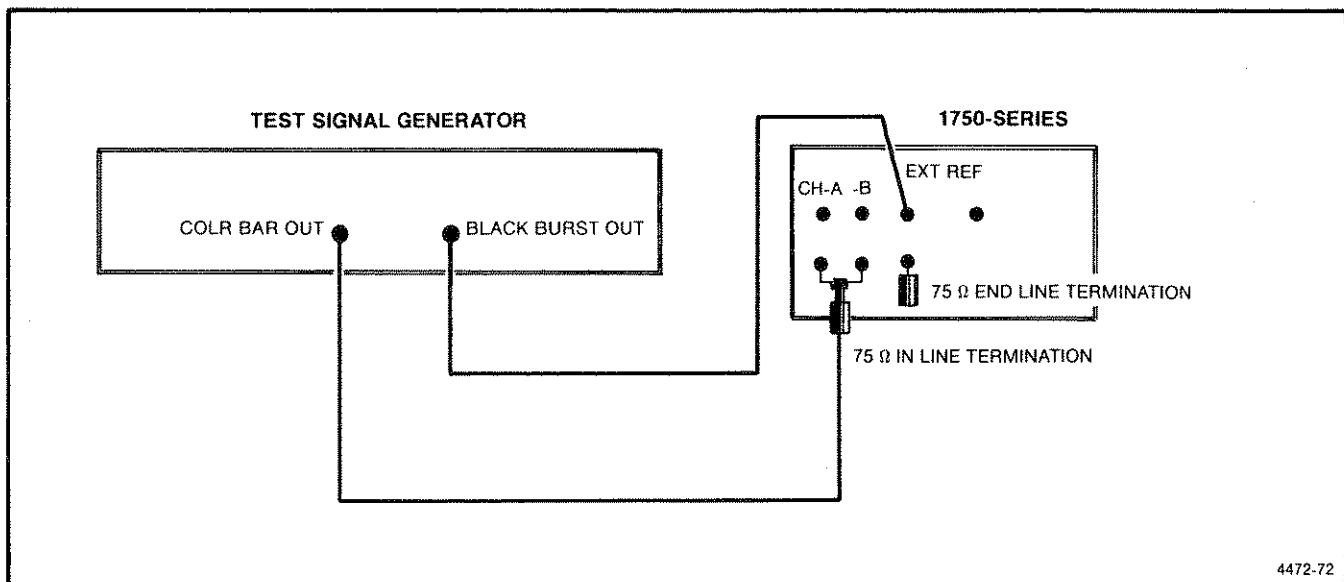

Fig. 5-8. Driving both CH-A and CH-B INPUTs with Color Bar signal.

a. Connect the Color Bar signal to CH-A INPUT. Select INPUT A and SCH Mode.

b. Connect the test oscilloscope X10 probe to TP898 on the SCH Logic board (Assembly A9). Dc couple the test scope vertical.

c. ADJUST—VCO1 (C694) on Assembly A9 for approximately  $-7$  V.

d. Connect the test oscilloscope X10 probe to TP760 on the SCH Logic board (Assembly A9). Dc couple the test scope vertical.

e. ADJUST—VCO2 (C852) on Assembly A9 for approximately  $-7$  V.

#### 24. Adjust SCH Balance

REQUIREMENT—Output levels from A4-U217 are balanced.

a. Connect Color Bar signal to the 1750-Series and terminate in  $75 \Omega$ . Select SCH Mode.

b. Connect both probes from the test oscilloscope Vertical Dual Trace Amplifier to A4-TP110 (Horizontal board). Set inputs to DC and use Position controls to overlay the displays.

c. Move one of the probes to A4-TP108. Do not change the test oscilloscope Vertical Position controls.

d. ADJUST—SCH Bal. (A4-R110) so that the sync tips overlay the blanking level of the opposite polarity displayed line.

#### 25. Adjust SCH Display Amplitude

REQUIREMENT—Sync dot and associated circle fall on the vector display compass rose.

a. Select the SCH Mode.

b. Check that the center dot falls at the exact center of the graticule (on the cross hairs). If not adjust 1750-Series VECTOR HORIZ POS and/or VECTOR VERT POS.

c. ADJUST—SCH AMP (R130) on Assembly A9 to place the sync dot and the circle on the Vector graticule compass rose.

#### 26. Adjust SCH Phase Calibration

REQUIREMENT—Phase of the SCH display equals the SCH phase of the input signal  $\pm 5^\circ$ , with a measurement range of  $\pm 80^\circ$  minimum.

a. Connect the Black Burst signal from the 1410 (1411) Mod AA to the test oscilloscope vertical input. Set the timebase for a  $10 \text{ ns/div}$  sweep.

b. 1751 and 1411 only. Apply Color Bar signal from the 1410 (1411) to the 1750-Series CH-A INPUT. Set for internal reference.

c. 1751 only; set the LINE SELECTOR to line 14, and trigger the test oscilloscope from TP609 on the SCH Logic board. Use delaying sweep.

d. Calibrate the 1410-Series Mod AA SCH phase. Refer to the 1410-Series manual for SCH Phase calibration instructions.

e. Select 1750-Series Vector Mode and use the PHASE control to place the burst vector(s) on the axis (axes).

f. Switch the 1750-Series to SCH Mode.

g. ADJUST—SCH1 (R136) on the Horizontal Assembly A4 to place the sync dot exactly on the B—Y (—U) axis.

h. ADJUST—REPhase Trip Point (R180) on Demodulator Assembly A5 to a point where the sync dot flips  $180^\circ$ .

i. ADJUST—SCH2 (R141) on the Horizontal Assembly A4 for symmetrical switching around the B—Y axis, while shifting SCH phase by adjusting the 1410 (1411) Horizontal Delay.

j. Repeat parts c through e, and if the sync dot does not line up on the left and have a lockin range of  $\pm 80^\circ$ , repeat parts f through h.

# MAINTENANCE

## Introduction

Included here are discussions of preventive maintenance, general troubleshooting information, detailed troubleshooting procedures and information, and corrective maintenance. If the instrument is not functioning properly, troubleshooting and/or corrective measures should be undertaken immediately; otherwise, additional problems may develop.

### CAUTION

*Do not allow water to get inside any enclosed assembly or components. Do not clean any plastic materials with organic cleaning solvents, such as benzene, toluene, xylene, acetone, or similar compounds, because they may damage the plastic.*

## PREVENTIVE MAINTENANCE

Preventive maintenance consists of cleaning, visual inspection, a performance check, and, if needed, readjustment. The preventive maintenance schedule established for an instrument should be based on the environment in which it is operated and the amount of use. Under average conditions, a preventive maintenance check should be performed every 2000 hours of instrument operation.

### Cleaning

The instrument should be cleaned often enough to prevent dust or dirt accumulation. Dirt acts as a thermal insulating blanket that prevents efficient heat dissipation while providing high-resistance electrical leakage paths between conductors or components in a humid environment.

**Exterior.** Clean the dust from the outside of the instrument by wiping or brushing the surface with a soft cloth or small brush. The brush will remove dust from around the selector buttons and connectors. Hardened dirt may be removed with a cloth dampened in water that contains a mild detergent. Do not use abrasive cleaners.

**Crt.** Clean the light filter, implosion shield, and crt face with a soft, lint-free cloth dampened in denatured alcohol.

**Interior.** Clean the interior by loosening accumulated dust with a dry soft brush, then remove the loosened dirt with low-pressure air (high-velocity air can damage some components). Hardened dirt or grease can be removed with a cotton-tipped applicator dampened with a solution of mild detergent in water. Do not use abrasive cleaners. If the circuit board assemblies need cleaning, remove the circuit board by referring to the instructions listed for Mechanical Disassembly/Assembly in this section. After cleaning, allow the interior to thoroughly dry before applying power to the instrument.

### Visual Inspection

After cleaning, carefully check the instrument for defective connections, damaged parts, and improperly seated transistors and integrated circuits. The remedy for most visible defects is obvious; however, if heat-damaged parts are discovered, try to determine the cause of overheating before the damaged part is replaced; otherwise the damage may be repeated.

### Static-Sensitive Components

### CAUTION

*Static discharge can damage any semiconductor component in this instrument.*

This instrument contains electrical components that are susceptible to damage from static discharge. See Table 6-1 for relative susceptibility of various classes of semiconductors. Static voltages of 1 kV to 30 kV are common in unprotected environments.

Observe the following precautions to avoid damage:

1. Minimize handling of static-sensitive components.
2. Transport and store static-sensitive components or assemblies in their original containers, on a metal rail, or on conductive foam. Label any package that contains static-sensitive assemblies or components.
3. Discharge the static voltage from your body by wearing a wrist grounding strap while handling these components. Servicing static-sensitive assemblies or components should be performed only at a static-free work station by qualified personnel.
4. Nothing capable of generating or holding a static charge should be allowed on the work station surface.

5. Keep the component leads shorted together whenever possible.
6. Pick up components by the body, never by the leads.
7. Do not slide the components over any surface.
8. Avoid handling components in areas that have a floor or work surface covering capable of generating a static charge.
9. Use a soldering iron that is connected to earth ground.

**Table 6-1**  
**RELATIVE SUSCEPTIBILITY**  
**TO STATIC DISCHARGE DAMAGE**

Semiconductor Classes	Relative Susceptibility Levels <sup>a</sup>
MOS or CMOS microcircuits or discretes, or linear microcircuits with MOS inputs. (Most Sensitive)	1
ECL	2
Schottky signal diodes	3
Schottky TTL	4
High-frequency bipolar transistors	5
JFETs	6
Linear microcircuits	7
Low-power Schottky TTL	8
TTL (Least Sensitive)	9

<sup>a</sup>Voltage equivalent for levels: (Voltage discharged from a 100 pF capacitor through a resistance of 100 Ω.)

1 = 100 to 500 V    4 = 500 V    7 = 400 to 1000 V (est.)  
 2 = 200 to 500 V    5 = 400 to 600 V    8 = 900 V  
 3 = 250 V    6 = 600 to 800 V    9 = 1200 V

**Performance Checks and Readjustment**

Instrument performance should be checked after each 2000 hours of operation, or every 12 months if the instrument is used intermittently. A regular check of instrument performance ensures maximum performance and assists in locating defects that may not be apparent during regular operation. Instructions for conducting a performance check and an adjustment procedure are provided in Section 5 of this manual.

**GENERAL TROUBLESHOOTING**

*NOTE*

*No repair should be attempted by the user during the warranty period.*

**Troubleshooting Aids**

**Foldout Pages.** The foldout pages of this manual contain significant information for troubleshooting the instrument. Block and schematic diagrams, waveforms, circuit board illustrations, and parts locating charts are located on foldout pages. See Fig. 6-1 for more information about their use.

**Diagrams.** See the Diagrams Section title page for definitions of the symbology used to identify circuit components. Refer to the Replaceable Electrical Parts list for a complete description of each component. Circuits that are mounted on circuit boards and special assemblies are enclosed in a gray border, with the name and assembly number shown on the border.

*NOTE*

*Check the Change information section at the rear of the manual for inserts describing corrections and modifications.*

**Circuit Board Illustrations.** Electrical components, connectors, and test points, for a specific diagram, are identified on circuit board illustrations located on the back of a preceding schematic diagram.

**Parts Locating Charts.** The schematic diagrams and the circuit board illustrations are assigned location grids. A parts locating chart for each assembly gives grid locations of components on both the circuit board illustration and the diagram.

**Assembly and Circuit Numbering.** The circuit board assemblies are assigned assembly numbers. Fig. 6-2 shows the location of the circuit board assemblies in the instrument.

The part numbers for ordering these boards are given in the Replaceable Electrical Parts list, Section 7.

Generally, each component is assigned a circuit number according to its geographic location within an assembly.

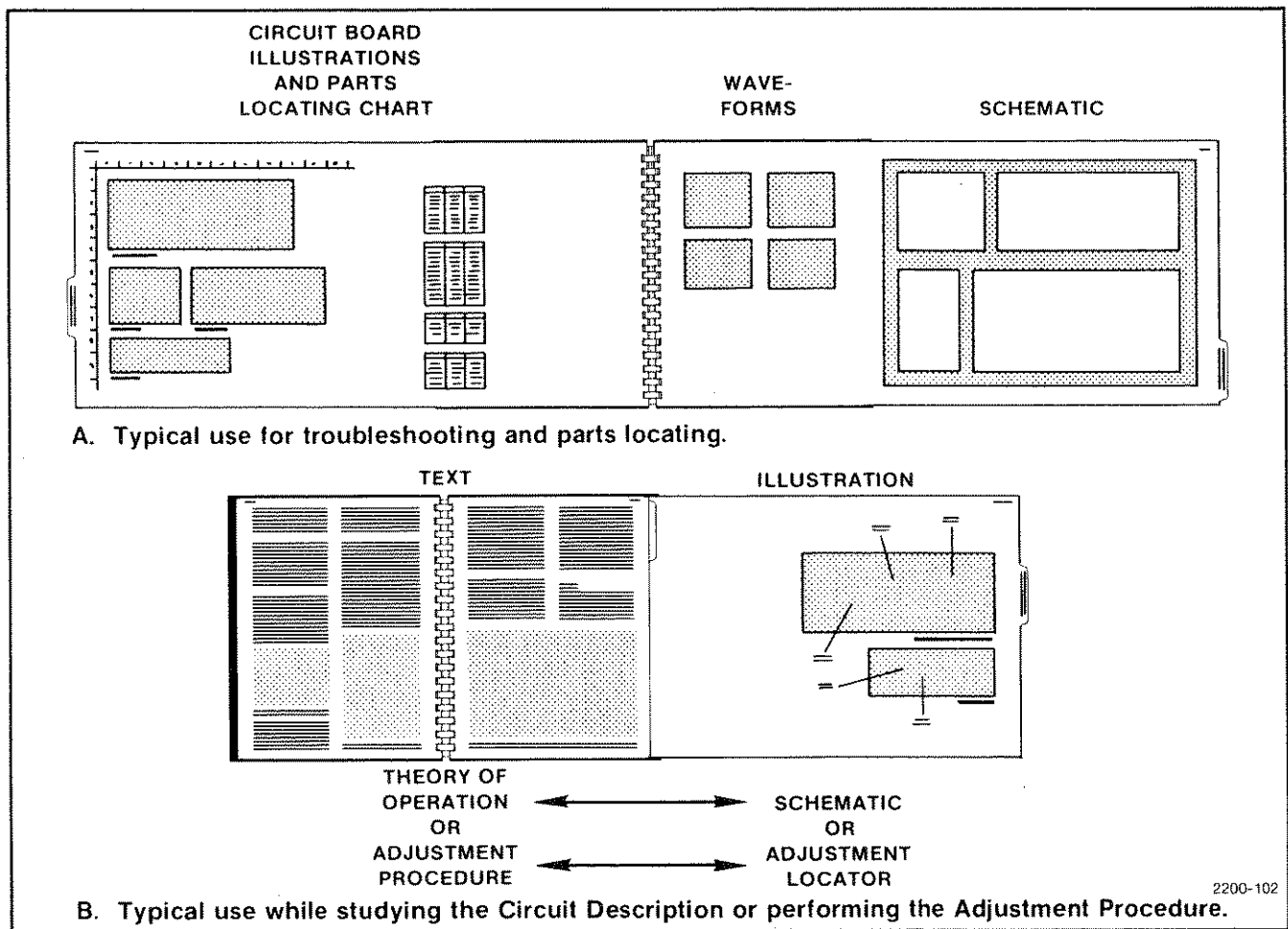

Fig. 6-1. Using the 1750-Series Instruction Manual fold-out pages.

The Replaceable Electrical Parts list is arranged in assembly-by-assembly order, as designated by ANSI Standard Y32.16-1975. The circuit number in the parts list is a combination of the assembly number and the circuit number.

EXAMPLE: R117 on A4 would be listed in the Replaceable Parts list as A4R117.

In the Replaceable Electrical Parts list, assemblies are listed first, followed by circuit-board mounted parts in alpha numeric order.

**NOTE**

*The complete parts list number and description should be used when ordering replacement parts.*

**Connectors.** Circuit board interconnections are made through multipin connectors. The harmonica-type connector

housings have numbers to identify terminal connectors (2 and up). A triangular key symbol is used to locate pin 1. A similar triangle symbol is used on the circuit board to identify pin 1.

Program and test plug jumpers use a box symbol to denote their factory-shipped operating position. A pin replacement kit including necessary tools, instructions, and replacement pins is available from Tektronix, Inc. See the Tektronix Part Numbers list at the end of this section.

**General Troubleshooting Technique**

The following procedure is recommended to isolate a problem and expedite repairs.

1. Be sure that the instrument is malfunctioning. Check the operation of associated equipment, input signal connections, and the front-panel controls. See Operating Instructions, Section 2.

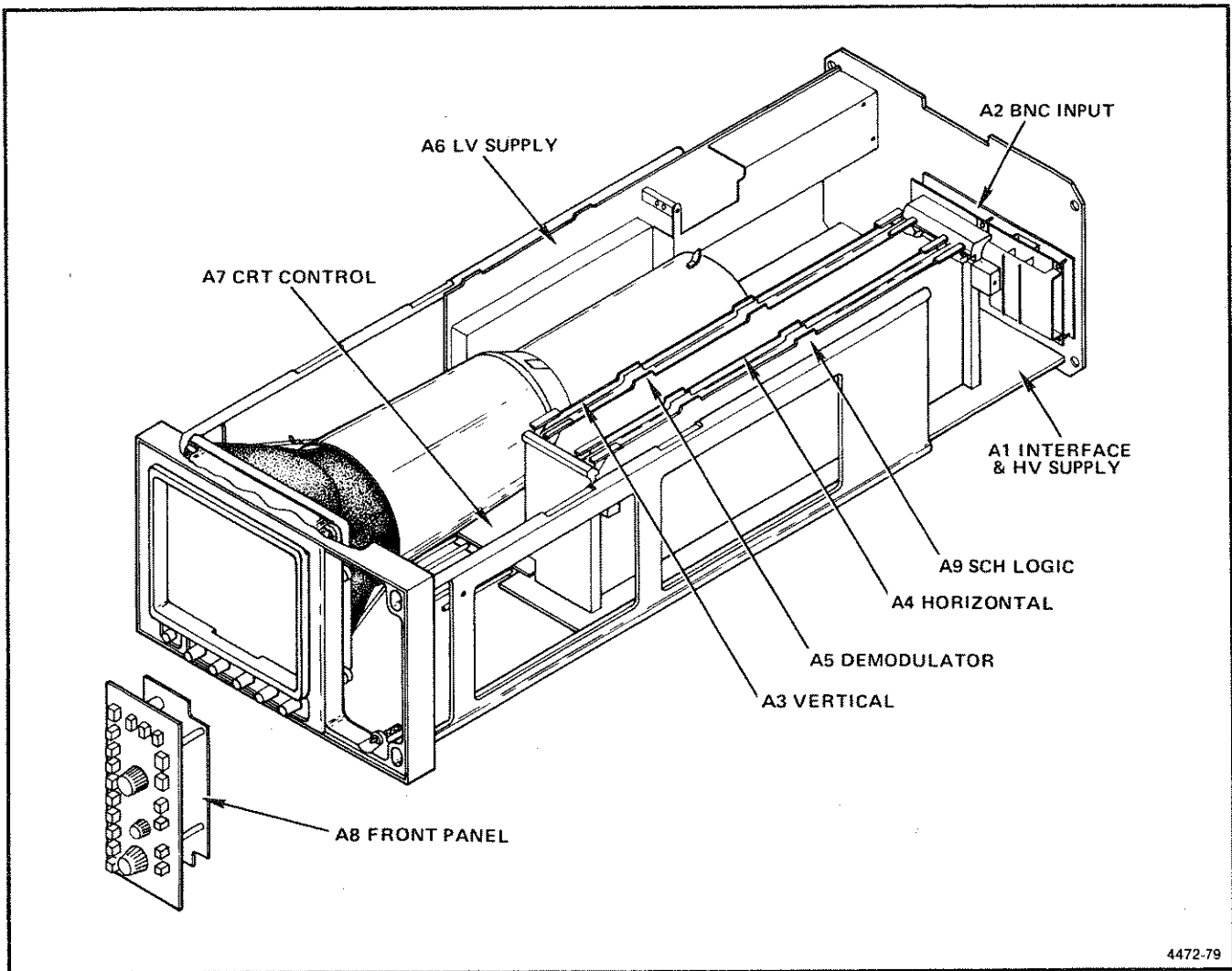

Fig. 6-2. 1750-Series assembly locations.

2. Determine and evaluate all trouble symptoms. Try to isolate the problem to a circuit or assembly. The block diagram in the Diagram section is intended for use in signal tracing and circuit isolation. The circuit boards are interconnected through the interface board which provides a means to easily isolate circuit boards. A test signal generator and an oscilloscope are necessary for some of the checks that follow.

**CAUTION**

*When measuring voltages and waveforms, use extreme care in positioning meter leads or probes because of high component density and limited access within the instrument.*

3. Determine the nature of the problem and the functional area most likely at fault.

4. Visually inspect the assembly for obvious defects (broken or loose connections, improperly seated components, overheated or burned components, chafed insulation, etc.). In the case of overheated components, try to determine the cause of the overheated condition and make corrections before reapplying power.

5. By successive electrical checks, locate the source of the problem.

6. Determine the extent of the repair needed; if complex, we recommend contacting your local Tektronix field office or representative. If minor, such as a simple component replacement, see the parts list for replacement information. Removal and replacement procedures of the assemblies are located in the Mechanical Disassembly/Assembly part of Corrective Maintenance.

## TROUBLESHOOTING PROCEDURE

This procedure is intended to guide a competent technician to the circuit block that has failed. The blocks are outlined and named on the schematic diagrams. This procedure is supported by the Theory of Operation, Section 4.

The procedure begins with a Problem Symptom Survey that leads to the Detailed Fault Isolation Procedure for the circuit boards or circuit blocks. Signal flow, feedback loops, and causes and effects are detailed here. Where useful, troubleshooting techniques are expanded; for example, the signature analysis used to troubleshoot the SCH Logic circuit board assembly.

### Starting Off

Survey the instrument using the symptom list. Then, survey the blocks within a major division of an assembly using the schematic diagrams. Next read the Detailed Fault Isolation Procedure and the applicable part of the Theory of Operation, Section 4. Assembly substitution may be used to isolate a fault to a circuit board. The Performance Check and Adjustment Procedures in Section 5 can also be used as a part of the troubleshooting procedure.

The circuit boards are referred to by assembly number (e.g., A4 refers to the Horizontal board). Fig. 6-2 provides the assembly names and locations.

To gain access to circuit boards A3, A4, A5, and A9, use an Extender board (optional accessory). Assemblies A1 and A6 cannot be placed on an extender. The circuit schematics have associated waveform photographs. Refer to the schematics and photographs as the fault isolation procedures are studied.

### 1750-Series Setup

Remove the 1750-Series Instrument from any carrying or rack adaptor. Connect a power cord to the power input connector. Set the controls as follows:

POWER	ON
INTENSITY	Set to Operator's preference
FOCUS	Set to Operator's preference
SCALE	Set to Operator's preference
VERT POS	Set to Operator's preference
HORIZ POS	Set to Operator's preference

WFM Mode  
2H SWEEP  
FLAT FILTER  
INPUT B

VARIABLE GAIN Detented (CAL)

## PROBLEM SYMPTOM SURVEY

The information here is organized by symptom, with potential problem sources discussed for each symptom. A short list summarizing potential problem sources is included for each symptom. For experienced troubleshooters, these lists may be enough to guide them to the fault source. When more information is needed, follow the reference numbers to corresponding steps in the Detailed Fault Isolation Procedure or to appropriate manual sections.

### Symptom: No Display in Waveform (WFM) Mode

#### Is the LV Power Supply working?

The LOCAL or REMOTE light should be on. If neither is on, go to the Power Supply survey section that follows:

LV supply:

Fuse open—9.

Line voltage selector set wrong—(Installation, Section 3).

#### Are the deflection outputs working?

Start with the instrument in Waveform Mode (WFM), FLAT response, 2H SWEEP, INPUT B, and Internal reference. Connect a Color Bar signal to B INPUT and terminate the loop-thru with 75  $\Omega$ . Observe the waveforms on the deflection plate leads.

**Vertical:** Measure the deflection signal at the stand up coils (LR143 and LR152) on A3 near the connection to the vertical deflection leads. The signal should be a composite video signal at approximately 20 Vdc. One of the leads should have an inverted signal. The VERTICAL POSITION control should control the dc level of the signal. If the amplifier output has no video or the output is against the supply, follow the Vertical board Fault Isolation Procedure, step 3.

**Horizontal:** Measure the deflection signal at the 1 watt precision resistors (R263 and R356) on A4 near the horizontal deflection plate leads. A ramp signal, 50 V p-p at 45 Vdc, should be present. The HORIZONTAL POSITION control should control the dc level of the signal. Limiting of the ramps occurs if the sweep MAG is on or the position control is at one side. One deflection signal should be inverted from the other. The Horizontal Fault Isolation Procedure will help find the reason for no ramp signal.

Deflection troubles:

Synchronization and Timing—1.

Vertical deflection off screen—3.

Horizontal deflection off screen—2.

**WARNING**

*Check the high voltage block with the power off. Several thousand volts of ac and dc are present in this area.*

If there still is no display, the next most likely problems are in the Z-Axis blocks. The High Voltage Fault Isolation Procedure gives methods of finding Z-Axis problems. The blanking input to the Z-Axis is the combination of three signal processing blocks. These are covered under a separate Blanking Fault Isolation Procedure.

**HV supply:**

- Wires are disconnected—8.
- Intensity problems, blanking problems—7.
- Bias problems—8.

**CRT Heater open—Schematic 7**

- CRT is always blanked in some modes—7.
- Blanking from Horizontal
- Blanking from Demodulator
- Blanking from Remote connector

- The blanking works but there is no brightness—8.
- CRT bias adjustments

**Symptom: Synchronizing Problems and Horizontal Sweep Problems**

Synchronization and timing pulses are essential to the operation of the instrument. These pulses should be checked before doing much other troubleshooting or replacement. They are generated on circuit board assembly A4 and their discussion is included in the Synchronization and Timing Fault Isolation Procedure.

Horizontal problems include sweep selection, the parade display, and nonlinearities. The Horizontal Sweep Fault Isolation Procedure includes these topics.

- Sync problems—1.
- Ramp problems—2.
- Sweep selection problems—11.
- Parade display problems—Theory of Operation, Section 4.

**Symptom: Vertical Problems**

Vertical problems include gain, filter response, signal selection, nonlinearities, and flat response. These are addressed in the Vertical Fault Isolation Procedure.

- Trace off screen
- Input selection
- Filter problems
- Gain problems

**Symptom: Vector, SCH, or R—Y (V-Axis for 1751) Problems**

The Demodulator furnishes outputs for both the Vector and R—Y displays. The Vector display shows all of the Demodulator output. The R—Y display shows the stability of the subcarrier phase lock loop. The Demodulator Fault Isolation Procedure covers these circuit blocks.

- Phase lock problems—5.
- One axis off screen—6.
- Field rate phase problems in R—Y (V-Axis 1751)—5.
- Blanking—6.

Frequency response—Checks and Adjustments, Section 5.

**Symptom: Power Supply Problems**

First check for an open fuse. If the power supply fuse opens repeatedly, follow the power supply troubleshooting procedures. Excessive ripple voltage can be a regulator problem or low input voltage. The series-pass regulated supplies (+12 V, -12 V, and +5 V) on each board (A1, A3, A4, A5, and A9) should be checked since they are current limited.

**Fuse open:**

- Transistors shorted
- Wrong line voltage

**Symptom: Function Control Problems**

The front-panel and REMOTE connector control are ground closures and either may be used. Only the push button functions are remotely controlled. The Operating Instructions, Section 2, explain the use of the controls. The function control Fault Isolation Procedure explains the troubleshooting procedure for this part of the instrument.

- Individual functions missing—11.
- Remote functions cannot be selected—11.



## DETAILED FAULT ISOLATION PROCEDURES

### HORIZONTAL BOARD (A4)

#### 1. Synchronization and Timing

Synchronization starts with decoding the timing information from the input signal. In addition, the instrument is designed to free run with no input signal and trigger on the internal calibrator signal in the 1H and 2H SWEEP modes.

The signal used as an internal timing reference is present at TP702 on A4. If there is no signal present, check back through the signal paths and the enable signal (U620 and U624, pin 5).

U400, on diagram 3, outputs a 5-V, p-p sync pulse (Sync 1) from a composite video or black burst input. It can be checked at TP629. The circuit will also work with sine waves to 1 MHz and square waves at line, field, and frame frequencies. This circuit is explained in the Theory of Operation, Section 4.

The Sync Separator triggers the Horizontal and Vertical sweeps, through the SCH Logic circuit board. One sweep is enabled at a time; however, the combination of 2H plus 1 FLD provides a  $0.5 \mu\text{s}/\text{DIV}$  sweep rate when magnified.

#### 2. Horizontal Sweeps

There are two independent sweep generators, one for line rates and one for field rates. Each will free run. Sweep retrigger prevention and hold off are contained in the Sweeps block on diagram 4. The rate of each sweep is doubled when Q775 is on. Q687 is an attenuator control used to shorten the sweep during parade displays.

The Staircase Input Amplifier output (TP580) is saturated to ground except when the staircase input is selected. This input to the MAG Amplifier can cause the sweep to be off the screen.

The Horizontal Mag Amp has three magnifier inputs (Q496, Q497, and Q395). Q496 is used with 2H SWEEP MAG, Q493 and Q396 are used for X20 mag with 1Field and 2Field SWEEP MAG, and all three are used for 1H SWEEP MAG. The output of this amplifier is 6 V p-p at TP284 with unmagnified sweeps. This output is detected by an off-screen blanking circuit.

The Horizontal Output Amplifier has inputs from the Horizontal Mag Amp and the B—Y Demodulator. It has a signal

input limiter to prevent amplifier saturation of the output. Limiting action for sweep inputs is done by CR275 and CR370 with the bias current in R371, R370, R271, and the Mag Registration control R180. The input switch controlled by Q180 and Q181 selects Sweep or Vector inputs. Unmagnified sweeps are 50 V p-p at the horizontal deflection leads.

Linearity of the horizontal deflection is a function of the open loop gain of the amplifiers and the bias currents. The open loop gain can be evaluated by the signal amplitude at amplifier summing junctions. Bias currents are analyzed by voltage levels and large-signal limiting voltages. The easiest troubleshooting method is to compare two instruments.

### VERTICAL BOARD (A3)

#### 3. Signal Amplifiers

The easiest way to troubleshoot the Vertical circuit board (A3) is to trace the signal through the major blocks.

In the Waveform Mode there are three signal inputs. INPUTs A, B, and the CALibrator are switched by U226, U426, and U326. A high input on pin 5 of these hybrid circuits should turn the switch on. The PIX MON OUT signal on the rear panel follows the input selection. The signal gain is approximately unity from the instrument input to the PIX MON OUT.

The Filters block has three response modes: FLAT, IRE (LUM), and CHROMA. The modes are selected by turning on Q655, Q755, or Q854 with a low from the switching logic. The inverting gain measured at TP239 to TP764 is 0.5.

The Variable Gain Amplifier (U468) is controlled from an input at pin 7. In UNCAL, the VAR control provides zero gain at zero volts, and a gain of one at 1/10 of the positive supply voltage. In CAL, the gain of this amplifier is approximately 0.65 measured at TP764 to TP371. The output of the amplifier drives the Chroma Amplifier and the DC Restored Amplifier.

The Chroma Amplifier controls the normal and X5 GAIN function for the Demodulator circuit board (A5). Normal gain occurs when Q674 is on. The output at TP662 is 0.6 V p-p chrominance for a Color Bar signal input. The CHROMA FILTER is automatically selected for Demodulator functions.

## Maintenance—1750-Series

The DC Restored Amplifier (TP379) is restored at the Clamp Pulse time. There is an option jumper, J188, on A9 for selection of back porch or sync tip clamping. The back porch or sync tip should be at 0 V at TP379. The outputs of sample-and-hold amplifier (U786) and restoration buffer amplifier (U780) should be less than 5 V from gnd. The dc restoration is automatically disabled by Q799 when the CALibrator INput is selected. The gain from the instrument input to TP379 is X2 with calibrated gain.

The Vertical Output Switch is controlled by Q393, Q394, and Q493. To be on, Q393 or Q394 collector should be above 0.7 V, or Q493 collector above 0 V. Bias control (R191) provides current for the switch control transistors. This current is adjusted so that the limiter (Q284 and Q283) prevents saturation of the output amplifier.

The voltage at TP286 and TP366 (approximately -7 Vdc) in the Vertical Output Amplifier is present at the collectors of Q248 and Q157. The gain from these test points to the output at LR143 and LR152 is X12.

Linearity of the Vertical Amplifiers is a function of the open loop gain of the amplifiers and the bias currents. The open loop gain can be evaluated by the signal amplitude at amplifier summing junctions. Bias currents are analyzed by voltage levels and large-signal limiting voltages. The easiest troubleshooting method is to compare two instruments.

## DEMODULATOR BOARD (A5)

### 4. Input Signals

This circuitry demodulates the chrominance of the video signal into two components that are 90° apart in the chrominance signal.

The reference for demodulation is from the Sync Separator. The reference input is found at TP778, which is the input to the Demodulator circuit board (A5), and at TP160 just before it is used by the phase lock loop.

These two test points are separated by a band-pass filter and a X6 amplifier. The chrominance signal to be demodulated passes through amplifier Q695 to Q595. The Chrominance Input Amplifier's gain from R695 to TP494 is approximately 1.75.

### 5. Subcarrier Phase Lock Loop

The primary problem that occurs in a phase lock loop is not locking. If it is not locked, an error voltage should appear at several points in the loop. This error voltage is nearly

a sine wave at the difference frequency between the subcarrier oscillator and the input reference. This sine wave may be absent or too small to lock the loop if a component is bad or if the frequency is too great to pass through a low-pass filter.

In this loop, the first filter and amplifier are R357 and C356 and U353A. The corner frequency of the filter is 8 kHz. Amplifier U353A is a X1 buffer for the voltage at TP250.

Sample-and-hold circuit U444 is used in PAL Demodulators (1751) to sample every other burst. For PAL Demodulators, the voltage at TP250 will be a square wave at 1/2 H rate. The error voltage at TP250, when unlocked, should be a sine wave in both NTSC and PAL Demodulators. See Fig. 6-3.

Amplifier U344 is a two-bandwidth active low-pass filter. If Q347 is on, the loop bandwidth should be high (approximately 1 kHz). If Q347 is off, the bandwidth should be low (approximately 10 Hz). This bandwidth change is accomplished by changing the gain of amplifier U344. If the gain in a part of the loop is much different than it should be, this bandwidth change will not function properly.

The gain of the voltage-controlled oscillator (Q545) is set by adjusting its frequency limits with the Adjustment Procedure, Section 5.

Another problem that can occur is an offset in the loop. A simple cause is the wrong setting of the Balance control (R173). An offset exists if the sine wave of the difference frequency is not centered about ground at U344, pin 6.

The function of the PAL Phase control is covered in the Theory of Operation, Section 4.

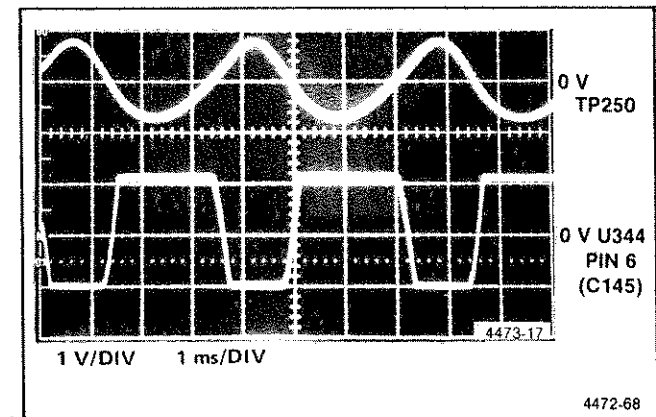

Fig. 6-3. Unlocked phase-locked loop error voltage.

## 6. Demodulator

The most frequent Demodulator problem occurs when an output has limited on a power supply. The position clamp function is a loop around the Chroma Demodulator. The position clamp can be bypassed by placing P112 or P816 in the 2-3 position. (It is normally quite easy to find the trouble without moving the jumper.) Proceed through the loop to look for a part that has not responded correctly to its inputs.

The current levels for the R-Y Demodulators are analyzed as an example. The current into U325, pin 5, is mirrored to the outputs, pins 6 and 9. If no current is flowing into pin 6, the voltage should be 6.75 V. The output, TP504, should be at ground during the sample time. The voltage at the emitter of Q408 should be 4.4 V, the voltage at Q309 emitter should be 3.85 V, and the voltage at U325, pin 6, should be 5.25 V. To lower the U325 voltage 1.5 V, current must be 3 mA. For 3 mA to flow in R222, the voltage at Q215's source should be 4.4 V.

### SCH LOGIC BOARD (A9)

The SCH Logic board is essential to all 1750-Series operations. It must be installed and operating in order to operate the monitor. This circuit board contains both analog and digital circuits. Once the analog circuitry is found to be fault free, signature analysis is the optimum method of isolating digital circuit faults.

First step in troubleshooting the SCH Logic circuit board is to make sure that the analog circuits are operating. The two identical 4-Fsc, crystal-controlled oscillators (U592 and U843) provide ECL outputs that are converted by U493 and U744 (ECL-TTL Converters). U292 and U661 are loadable up/down counters that are normally configured to count to 5. Finally, U586 and U643 are the Intraline Counters and the MSB (pin 8) must toggle for the digital circuitry to function. Once all analog circuits are operational, the remainder of the circuits are best troubleshot using a signature analyzer.

### Signature Analysis

Because there are no internal processors and external stimulation is not required the five individual signature setups are nearly identical. The correct signatures are contained in Tables 6-2 and 6-3. In all cases the signature analyzer is triggered on a rising edge and the start and stop, coming from a common source, is set-up for a falling edge. In addition, it should be noted that there are no tri-state devices on this board and no pull-up resistors are required.

Preparation for Signature Analysis—All input signals to the 1750-Series must be removed. The internal line selection switch (5-segment DIP switch on the SCH Logic Circuit

board) must have all segments in the open position. The 1750-Series right side front panel should be set up as follows.

WFM, R-Y (V AXIS), VECT,	
SCH	--- XX
SWEEPS	--- XX
MAG	--- off
input A (or B)	--- A
+V / PAL (1751)	--- PAL (out)
CAL	--- off
EXT REF	--- off
X5	--- off
DC REST	--- off
LINE SELECTOR	--- off
FILTERS	--- FLAT
FIELD	--- 1, 3

The following plug jumpers must be moved to the TEST position. (Also remember that they must be returned to the OPERATE position when signature analysis is completed. The OPERATE position is denoted by a box shaped marking on the circuit board.):

P105  
P125  
P266  
P302  
P340  
P344  
P376  
P386  
P805

There are also other jumpers that will have to be moved as part of a specific setup for checking a specific circuitry node.

The five specific test setups are described here and the correct signatures, along with specific condition changes, are listed in Table 6-2 and Table 6-3.

Setup 1:	Clock lead to J397 Stop and Start leads to TP380
Setup 2:	Clock lead to J553 Stop and Start leads to TP306
Setup 3:	Clock lead to J553 Stop and Start leads to TP735 Remove Plug Jumper P205
Setup 4:	Clock lead to J553 Stop and Start leads to TP609 P205, P710, and P805 in TEST position 1750-Series front-panel LINE SELECTOR, ON

Setup 5: Clock lead to J553  
Stop and Start leads to TP735  
Remove Plug Jumper P205  
P335 in TEST position  
1750-Series front-panel LINE SELEC-  
TOR, ON

Table 6-2  
1750 (NTSC) SIGNATURE TABLE

Table 6-3  
1751 (PAL) SIGNATURE TABLE

See Change information at rear of manual.

See Change information at rear of manual.

## OTHER FUNCTIONS

### 7. Blanking Circuits

Blanking of the crt can be from two sources, internal or external. The external blanking input is pin 6 of the 25-pin REMOTE connector. A low input will blank the picture. Board A3 has no internal connection to the blanking line.

The Horizontal board (A4) provides sweep blanking information to the Logic board as dictated by outputs from J385. These are shown on schematic 4 at the right hand side. Only one sweep will be running at a time. Off-screen blanking is activated if the Mag Amplifier output (TP284) has reached ground or +12 V. Vector Mode selection deactivates these two blanking inputs.

The Demodulator (A5) does not blank the display unless the input signal is quite small. The Vector Clamp unblanks the display for approximately 2  $\mu$ s during sync time so that a center dot will always be displayed. The limiter circuit in the Center Dot Blanking on schematic 5 serves as an automatic color killer. Center dot blanking is disabled when the instrument is not in Vector Mode.

### 8. Z-Axis/HV Problems

Since the crt is a voltage-controlled device, the currents are quite small. Therefore, the main troubleshooting method is voltage measurement. The cathode voltage is  $-3$  kV so that the deflection plates will be at voltages convenient for bipolar transistors. The Anode (faceplate) voltage is +12 kV. The current in the tube is controlled by the relative voltage on three pins (cathode, pin 2; control grid, pin 3; and screen grid, pin 4). If the control grid voltage is at the same potential as the cathode, the crt current is described by the

diode curve for the cathode and screen grid. This current may be reduced to zero by lowering the control grid voltage below the cathode to the cutoff voltage. The cutoff voltage for a particular crt is a function of the cathode to screen grid voltage and of the physical spacings between the cathode and control grid. This voltage is different for each crt and it must be set by the procedure in the Adjustment Procedure, Section 5. This voltage is controlled by the Z-Axis input as is described in the Theory of Operation, Section 4.

### WARNING

*The voltages in the cathode section of the HV Supply block are greater than usually encountered in other circuits. If it is necessary to make these measurements, use voltage probes with adequate ratings and use care not to cause arcs between components or to yourself.*

The Z-Axis has inputs from the Intensity and Blanking circuits. They are combined and amplified. The composite can be observed at TP558 on the Interface and HV Power Supply board at the bottom of the instrument. Access to this test point may be gained by removing the bottom cover. The waveform should be a rectangular wave. The low excursion is fixed. The high excursion is set by the INTENSITY control. This circuit is described in the Theory of Operation, Section 4.

### 9. Low Voltage Supply

The most immediate cause of the Low Voltage Supply (A6)—shown on diagram 11—not operating is an open fuse. Therefore, the first thing to check is the rear-panel mounted fuse and the adjacent Line Voltage Selector switch. Any internal troubleshooting, utilizing grounded probes will require an isolation transformer.

If the fuse is good and the Line Voltage Selector switch is in the correct position, check to see that neon indicator, DS770, is blinking steadily. If it is not, check for 300 V across the output of CR278.

If the power supply is attempting to start, but shuts down right away, check for overcurrent. Voltage at R540 should be less than 1 V; if greater than 1 V check for short in load. The power supply can be operated without other circuit boards, by removing from interface and using a 5  $\Omega$ , 5-watt resistor across J964, pins 4 and 8 (or 4 and 1). Possible problems on the Power Supply circuit board include shorted diodes in secondary, or defective secondary winding.

If the power supply does not attempt to start, but DS770 is blinking, check the start circuit. C342 and Q537 are the key elements. If C342 charges, U529 should intermittently start-up and discharge it.

If there is no overcurrent condition, check the ramp signal on U529, pin 5. Ramp should be occurring at a 200-kHz rate. Be sure to use ground 2.

Check undervoltage (Q430, Q432, and Q427). If 300 V supply is too low, this circuit holds U529, pin 4, high and inhibits U529 from starting.

## 10. Function Control

The logic levels from the front-panel switches and the remote control function are present at J297 on A1, shown on diagram 9. The bottom of this connector is accessible after the instrument has been removed from the cabinet or from the rack enclosure. The remote or local control enable function is accomplished by electronic switches so that both sections of the enable switching must be checked. U111, U311, and U409 are tri-state octal buffers for the remote inputs. The buffer inputs are on the left with the outputs shown directly across from the inputs.

There is a default function selection if both the front panel and remote inputs are disabled. The instrument mode will be INPUT A, Vector Mode, CHROMA FILTER, and Internal Reference. PAL switching is selected for the 1751.

## CORRECTIVE MAINTENANCE

Corrective maintenance covers obtaining replacement parts, selected components, torque specifications, and component and assembly replacement. A list of Tektronix part numbers for recommended service items and repackaging information is included with the discussion.

### Obtaining Replacement Parts

Replacement parts are available from or through the local Tektronix, Inc., field office or representative.

Changes to Tektronix instruments are sometimes made to accommodate improved components as they become available, and to give you the benefit of the latest circuit improvements. It is important to include the following information in your order, when ordering replacement parts:

1. Part Number
2. Instrument Type or Number
3. Serial Number

## SELECTED COMPONENTS

### Demodulator Board A5

Phase Shift/Burst Amplitude. A5R556, shown on diagram 5, is test selectable to minimize phase shift with burst amplitude change. The nominal value is 1.2 k $\Omega$ , with a selectable range of 900 to 2 k $\Omega$ .

The resistor sets the saturation of Q456 and Q457 so that they have symmetrical waveforms at their collectors. Delay caused by mismatched saturation times causes the phase shift.

### Torque Specifications

#### NOTE

*Be sure to use the proper torque setting to avoid stripping a screw, warping a panel, or damaging components when reassembling the instrument.*

The 1750-Series torque specifications are:

2-56 PNH	1.75 to 2.25 in/lbs
4-40 PNH and FLH	3.5 to 5.0 in/lbs
6-32 PNH and FLH	7.0 to 9.0 in/lbs
8-32 PNH	14.0 to 18.0 in/lbs
10-32 FLH	25.0 to 30.0 in/lbs

Exceptions and additions to the torque specifications list are:

1. The 4-20 PNH Plastite screws securing the ecb guides to the A1 Interface and HV Power Supply board—10.0 to 11.0 in/lbs.
2. The 4-40 PNH thread-cutting screws securing the center of the ecb shields to the A1 Interface and LV Power Supply board—3.0 in/lbs.
3. The 6-19 PNH thread-forming screws securing the plastic retainers to the crt ring—12.0 to 15.0 in/lbs.
4. The 8-32 FIL thread-forming screws securing the crt retainer ring—8 in/lbs.
5. The 8-32 FIL thread-forming screws securing the front casting to the side rails—22 in/lbs.
6. The 4-40 Hex spacer securing the rear panel to the Remote connector—3.5 to 4.5 in/lbs.

## MECHANICAL DISASSEMBLY/ASSEMBLY

Before removing parts from the 1750-Series instrument, disconnect the power cord and then remove the instrument

from the rack adaptor or from its carrying case. (Two screws at the upper corners of the rear panel secure the instrument in the cabinet.) Reassembly is performed by reversing the steps used to disassemble the instrument.

**WARNING**

*For your protection and to avoid damage to the instrument, when removing or replacing any of the circuit boards, shut the instrument power off.*

### Plug-in Circuit Board Removal

The Vertical (A3), Horizontal (A4), Demodulator (A5), and SCH Logic (A9) circuit boards plug directly into the Interface and HV Power Supply board (A1). Before removing any of the plug-in circuit boards, disconnect any wires that are attached or blocking removal. Note the wire locations for replacement. Remove the circuit boards by lifting up on the inner end of the circuit board ejectors.

The boards may be operated on an optional accessory extender board without the deflection leads connected to the crt. Set the crt INTENSity control to minimum to avoid burning the crt when wires are disconnected. A set of four Deflection Lead Extender Cables is available to operate the crt with a board extended. Extender board and deflection lead part numbers are included in the Tektronix Part Numbers list at the end of this section.

### Front-Panel Assembly (A8) Removal

1. Remove the crt bezel by pulling out on its lower edge near the crt faceplate.
2. Set the instrument on its side so that the control panel is up.
3. Loosen the upper and lower thumb screws (behind the front casting).
4. As the assembly is separated from the instrument, remove the harmonica connector with the coax cables from J128 on the Demodulator board (A5), and the ribbon cable connectors from J607 on the SCH Logic board (A9) and from J125 on the Front-Panel assembly (A8).

**NOTE**

*When reinstalling the Front-Panel assembly (A8), be sure that the plug to J128 on the Demodulator board (A5) is installed with the open side of the connector facing outward. This matches pin 1 of the plug and jack.*

### Graticule Light Removal

1. Use a small screwdriver to pry the light holder assembly from the left side of the front casting. Pry gently at top and bottom of holder; do not use excessive force.
2. Remove the harmonica connector from J995 on the Interface and HV Power Supply board (A1).

Once the light holder assembly has been removed, individual light bulbs can be replaced.

### Separating the Instrument (See Fig. 6-4.)

The instrument can be physically separated into two pieces. One piece contains the crt, front-panel casting, Front-Panel assembly (A8), side panels, and bottom panel. The other piece contains the rear panel and the remaining circuit board assemblies. The Front-Panel assembly (A8) can be left attached to the front casting, or can be removed and connected to the Interface (A1), Demodulator (A5), and SCH Logic (A9) boards for operation while the two pieces are separated.

1. Remove the two plastic circuit board retainers (two screws each).
2. Remove the two screws from the right side panel (facing the instrument).
3. Remove the two screws from the left side panel.
4. Disconnect the following items:
  - a. Graticule light cable to J995 on the Interface board (A1).
  - b. Crt anode (post) connector.

**WARNING**

*The crt may retain a dangerous charge. Ground the conductor of the anode connector to discharge the crt.*

*Do not allow the conductor to touch your body or any circuitry.*

- c. Crt socket
- d. Crt deflection leads (4) from the Vertical (A3) and Horizontal (A4) boards.
- e. Crt shield front and rear ground leads.

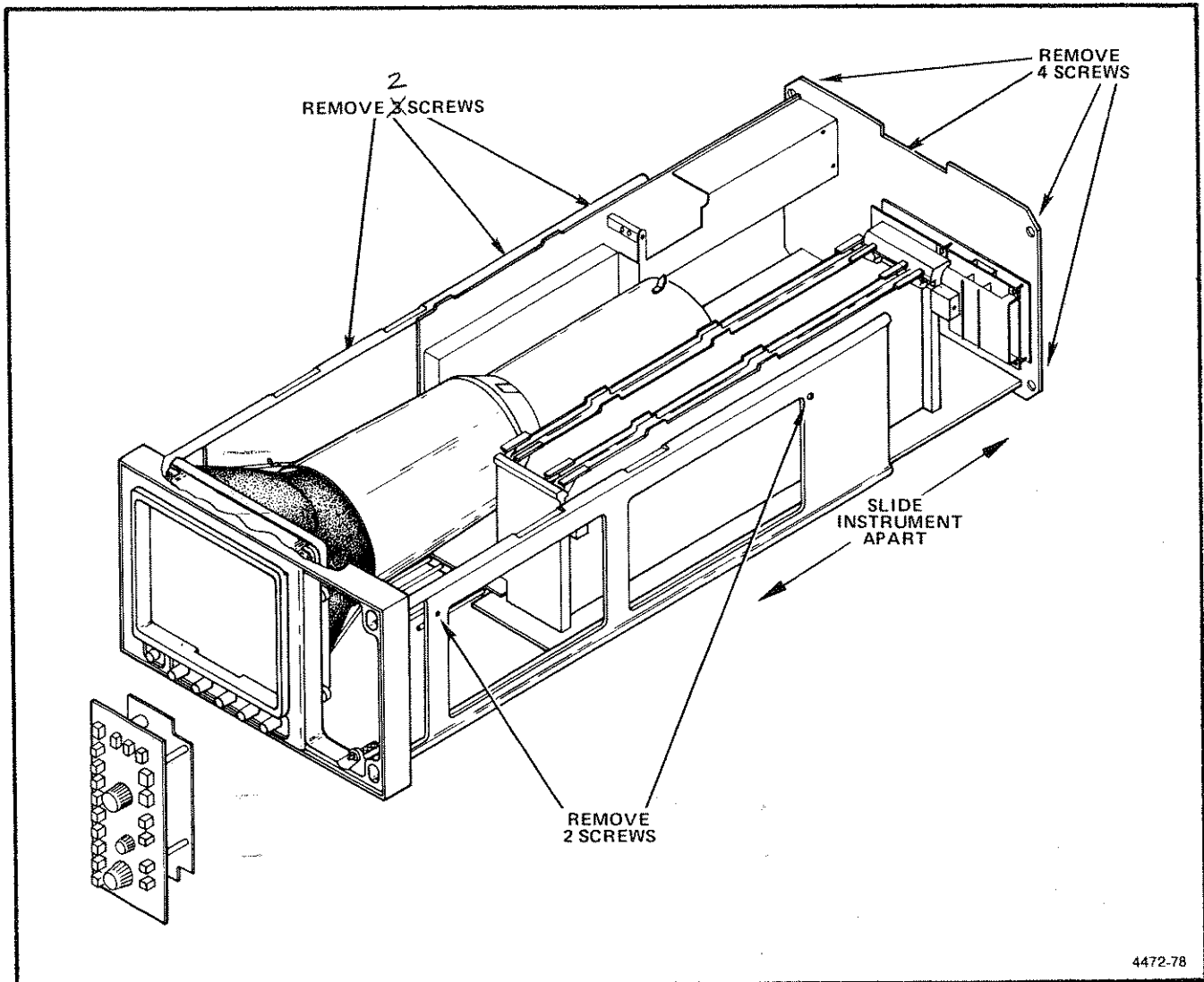

4472-78

Fig. 6-4. Separating the instrument.

- f. Trace Rotation and Y Align cable from J300 on the LV Power Supply board (A6).
  - g. Phase Shifter cables J124 and J125 on the Demodulator board (A5). (B01 uses a harmonica connector, J124 only.)
  - h. Ribbon cable from J297 on the Interface and HV board (A1).
  - i. Ribbon cable from J607 on the SCH Logic board (A9).
6. Carefully slide the instrument apart. When reinserting the control shafts into the front casting, align the front-panel knobs to the shafts.

#### Replacing the BNC Input Assembly (A2).

1. Separate the instrument (see that procedure) to gain clearance to remove the assembly.
2. Remove the three screws through the rear panel. As the assembly is removed from the instrument, remove the three Peltola connectors from the Vertical board.

#### CAUTION

*When reinstalling the Peltola connectors take care that the center conductor is not bent before it enters the socket at the bottom of the connector. Pull the Vertical board (A3) part of the way out of the instrument to ease the reinstallation of the Peltola connectors.*

### LV Power Supply board (A6) Removal

**WARNING**

*Dangerous voltages exist at these points. Be sure that the power cord is disconnected, and that the high voltage points have been discharged.*

1. Remove the two LV Power Supply board securing screws.
2. Remove P800 from the LV Power Supply board (A6).
3. Gently pull the LV Power Supply board (A6) up and slightly in.

The assembly is now completely detached from the instrument. To remove parts from the board remove the clear plastic shield from behind the board (held with two flathead screws).

### Interface and HV Supply Board (A1) Removal

The Interface and HV Supply board (A1) is most easily removed when the instrument is separated. Once the instrument is separated almost all repair operations can be performed without removing the Interface and HV Supply board from the supporting metal work. In order to remove this board from the rear and side panels, use the following procedure:

1. Remove all plug-in circuit boards, including the LV Power Supply (A6). Be sure to unplug the four Peltola connectors to the Vertical board (A3) and the two (B02 and above) to the Demodulator board (A5).
2. Remove the two plastic supports for the circuit boards.
3. Remove the three screws holding the plastic cover over the bottom left corner of the Interface.
4. Unsolder the leads from the Mains Line Filter to the Interface and HV Supply board (A1).
5. Remove the four rear-panel multi-pin socket mounting nuts.
6. Remove the rear-panel screw (near fuse holder) that secures the metal mounting block.
7. Separate the Interface and HV Supply board (A1) from the rear panel.

### Removing CRT Control Board (A7)

1. Remove the four screws securing the CRT Control board (A7) to the Interface and HV Supply board (A1).

### CRT Removal

1. Separate the instrument. See preceding procedure.
2. To remove the crt, first remove the bezel by pulling out on the bottom edge where it is against the crt. Set the bezel and filter aside.

**WARNING**

*The crt may retain a dangerous charge. Ground the conductor of the anode connector to discharge the crt. Do not allow the conductor to touch your body or any circuitry.*

**CAUTION**

*The crt deflection leads and base socket must be removed with care to avoid bending the pins and causing an air leak in the crt.*

3. Remove the four TORX® screws that mount the crt shield assembly. See Fig. 6-5. They are located in indentations near the four corners of the crt. Note that left ones are toward the inside.
4. Slide the crt assembly out of the instrument.

To replace the crt:

5. Slip the compression ring off the neck shield. Carefully slip the shield off the crt taking care not to bend the neck pins.

**CAUTION**

*Crt shield must be handled carefully. Its magnetic effectiveness will be reduced if it is even slightly damaged.*

6. If the Y Alignment and Trace Rotation coil assembly must be replaced, access is now possible to these parts inside the shield.
7. Before reassembly, clean the crt filters. Use only mild soap, water, and a soft cloth. Reinstall the ring that protects the front of the shield if it came off when the crt was removed. Transfer the O-Ring from the neck of the crt being replaced to the new crt. Assure that the openings in the shield are aligned with the crt neck pins and that the graticule is right side up.



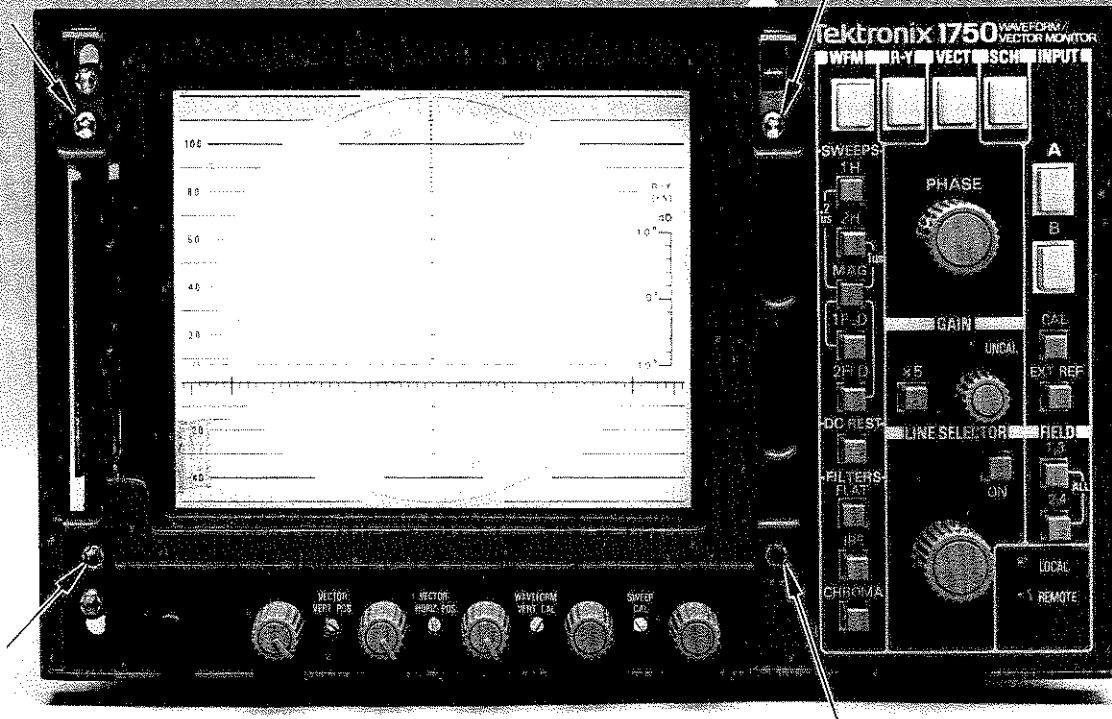

4472-76

Fig. 6-5. Location of the four screws securing the crt assembly to the front panel.

8. When reassembling the crt, tighten the TORX® screws in the compression ring to 8 inch-pounds. Also, align the knobs below the crt to their respective shafts as the front casting is rejoined with the rest of the instrument.

To remove the rear panel:

1. Remove the screws:
  - a. Remove the two stand-offs at each REMOTE connector.
  - b. Remove the screw at the right side of the ac power input connectors.
  - c. Remove the four corner screws.
2. Disconnect the wires:
  - a. Pull the rear panel away from the instrument and remove the connectors from J715, J414, and J415

on the Interface and LV Supply board (A1), and from the four coax cables to the Vertical board (A3).

#### NOTE

When replacing the coaxes make certain that the center conductor is not bent as it is being inserted.

3. Remove the Vertical board from the instrument part way to ease reinsertion of the coaxes.
4. Remove the rear panel from the instrument.

#### Tektronix Part Numbers

Table 6-4 lists Tektronix part numbers for recommended service items.

**Table 6-4**  
**RECOMMENDED SERVICE ITEMS**

Item	Tektronix Part Number
Connector Pin Replacement Kit	040-0542-00
64-Pin Extender Board	670-7980-00
32-Pin Extender Board	670-7981-00
CRT Extender Leads (4)	196-0939-00
BNC to Peltola Extender Cable	067-0709-00

**Repackaging**

If the instrument is to be shipped to a Tektronix Service Center for service or repair, attach a tag to the instrument showing:

1. Owner (with complete address) and the name of a person at your firm that can be contacted.
2. Instrument serial number and a description of the service required.

Repackage the instrument in the original manner for maximum protection (see Fig. 6-6). Save and reuse the package in which your instrument was shipped. If the original packaging is unfit for use or not available, repackage the instrument as follows:

1. Obtain a carton of corrugated cardboard having inside dimensions of six inches, or more, greater than the dimensions of the instrument. This will allow for cushioning. Use a shipping carton that has a test strength of at least 275 pounds.
2. Surround the instrument with polyethylene sheeting to protect the finish.
3. Cushion the instrument on all sides by tightly packing dunnage or urethane foam between carton and instrument. Allow three inches on all sides for cushioning.
4. Seal the carton with shipping tape or industrial stapler.

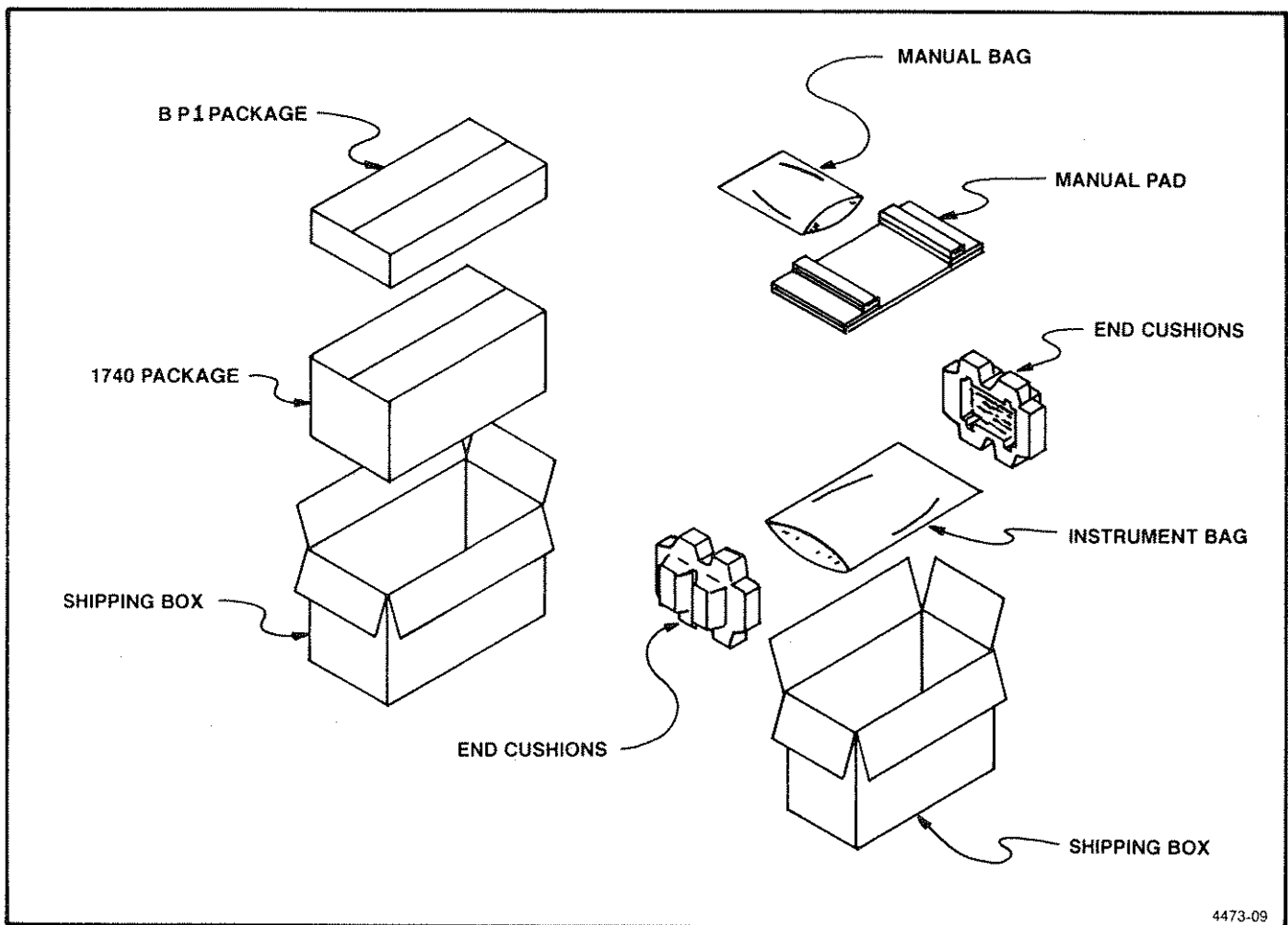

**Fig. 6-6. Repackaging.**