

Service Manual

Tektronix

**494A & 494AP
Spectrum Analyzers
Volume 2**

070-5561-00

Warning

The servicing instructions are for use by qualified personnel only. To avoid personal injury, do not perform any servicing unless you are qualified to do so. Refer to the Safety Summary prior to performing service.

Please check for change information at the rear of this manual.

First Edition: January 1987
Last Revised: December 1992

Copyright © Tektronix, Inc. 1987. All rights reserved.

Tektronix products are covered by U.S. and foreign patents, issued and pending. Information in this publication supercedes that in all previously published material. Specifications and price change privileges reserved.

Printed in the U.S.A.

Tektronix, Inc., P.O. Box 1000, Wilsonville, OR 97070-1000

TEKTRONIX and TEK are registered trademarks of Tektronix, Inc.

RELEASE OF COPYRIGHT

Tektronix cannot provide manuals for measurement products that are no longer eligible for long term support. Tektronix hereby grants permission and license for others to reproduce and distribute copies of any Tektronix measurement product manual, including user manuals, operator's manuals, service manuals, and the like, that (a) have a Tektronix Part Number and (b) are for a measurement product that is no longer supported by Tektronix. A Tektronix manual may be revised to reflect changes made to the product during its manufacturing life. Thus, different versions of a manual may exist for any given product. Care should be taken to ensure that one obtains the proper manual version for a specific product serial number. This permission and license does not apply to any manual or other publication that is still available from Tektronix, or to any manual or other publication for a video production product or a color printer product. Tektronix does not warrant the accuracy or completeness of the information, text, graphics, schematics, parts lists, or other material contained within any measurement product manual or other publication that is not supplied by Tektronix or that is produced or distributed in accordance with the permission and license set forth above. TEKTRONIX SHALL NOT BE LIABLE FOR ANY DAMAGES WHATSOEVER (INCLUDING, WITHOUT LIMITATION, ANY CONSEQUENTIAL OR INCIDENTAL DAMAGES, DAMAGES FOR LOSS OF PROFITS, BUSINESS INTERRUPTION, OR FOR INFRINGEMENT OF INTELLECTUAL PROPERTY) ARISING OUT OF THE USE OF ANY MEASUREMENT PRODUCT MANUAL OR OTHER PUBLICATION PRODUCED OR DISTRIBUTED IN ACCORDANCE WITH THE PERMISSION AND LICENSE SET FORTH ABOVE

Thomas F. Lenihan Chief Intellectual Property Counsel Tektronix, Inc (503) 627-7266

WARRANTY

Tektronix warrants that this product will be free from defects in materials and workmanship for a period of one (1) year from the date of shipment. If any such product proves defective during this warranty period, Tektronix, at its option, either will repair the defective product without charge for parts and labor, or will provide a replacement in exchange for the defective product.

In order to obtain service under this warranty, Customer must notify Tektronix of the defect before the expiration of the warranty period and make suitable arrangements for the performance of service. Customer shall be responsible for packaging and shipping the defective product to the service center designated by Tektronix, with shipping charges prepaid. Tektronix shall pay for the return of the product to Customer if the shipment is to a location within the country in which the Tektronix service center is located. Customer shall be responsible for paying all shipping charges, duties, taxes, and any other charges for products returned to any other locations.

This warranty shall not apply to any defect, failure or damage caused by improper use or improper or inadequate maintenance and care. Tektronix shall not be obligated to furnish service under this warranty a) to repair damage resulting from attempts by personnel other than Tektronix representatives to install, repair or service the product; b) to repair damage resulting from improper use or connection to incompatible equipment; or c) to service a product that has been modified or integrated with other products when the effect of such modification or integration increases the time or difficulty of servicing the product.

THIS WARRANTY IS GIVEN BY TEKTRONIX WITH RESPECT TO THIS PRODUCT IN LIEU OF ANY OTHER WARRANTIES, EXPRESSED OR IMPLIED. TEKTRONIX AND ITS VENDORS DISCLAIM ANY IMPLIED WARRANTIES OF MERCHANTABILITY OR FITNESS FOR A PARTICULAR PURPOSE. TEKTRONIX' RESPONSIBILITY TO REPAIR OR REPLACE DEFECTIVE PRODUCTS IS THE SOLE AND EXCLUSIVE REMEDY PROVIDED TO THE CUSTOMER FOR BREACH OF THIS WARRANTY. TEKTRONIX AND ITS VENDORS WILL NOT BE LIABLE FOR ANY INDIRECT, SPECIAL, INCIDENTAL, OR CONSEQUENTIAL DAMAGES IRRESPECTIVE OF WHETHER TEKTRONIX OR THE VENDOR HAS ADVANCE NOTICE OF THE POSSIBILITY OF SUCH DAMAGES.

TABLE OF CONTENTS

This manual is divided into two volumes.

VOLUME 1

	PREFACE		
	SERVICING SAFETY SUMMARY		
Section 1	GENERAL INFORMATION	Section 4	PERFORMANCE CHECK
Section 2	SPECIFICATION	Section 5	ADJUSTMENT PROCEDURE
Section 3	INSTALLATION	Section 6	MAINTENANCE
		Section 7	THEORY OF OPERATION
		Section 8	OPTIONS
		Appendix A	GLOSSARY

VOLUME 2

	SERVICING SAFETY SUMMARY		
Section 9	REPLACEABLE ELECTRICAL PARTS	Section 10	DIAGRAMS (CONT.)
Section 10	DIAGRAMS		24 VIDEO PROCESSOR
	1 FUNCTIONAL BLOCK		25 VERTICAL DIGITAL STORAGE
	2 1st CONVERTER BLOCK		26 HORIZONTAL DIGITAL STORAGE
	3 2nd CONVERTERS BLOCK		27 DEFLECTION AMPLIFIERS
	4 3rd CONVERTER BLOCK		28 Z-AXIS & RF INTERFACE
	5 IF BLOCK		29 HIGH VOLTAGE SUPPLY
	6 DISPLAY CONTROL BLOCK		30 CRT READOUT
	7 FREQUENCY CONTROL BLOCK		31 SWEEP
	8 COUNTER & PHASE LOCK BLOCK		32 SPAN ATTENUATOR
	9 DIGITAL CONTROL BLOCK		33 1st LO DRIVER
	10 POWER SUPPLY BLOCK		34 PRESELECTOR DRIVER
	11 RF DECK INTERCONNECT		35 CENTER FREQUENCY CONTROL
	12 1st CONVERTER & 2072 MHz 2nd CONVERTER		36 HARMONIC MIXER & PHASE GATE
	13 PHASE LOCKED 2nd LO (16-20 MHz PHASE LOCK)		37 AUXILIARY SYNTHESIZER
	14 PHASE LOCKED 2nd LO (LO & 2200 MHz REF/CONV.)		38 COUNTER
	15 829 MHz 2nd CONVERTER (LO SECTION)		39 PHASE LOCK SYNTHESIZER (SYNTHESIZER)
	16 829 MHz 2nd CONVERTER (IF SECTION)		40 PHASE LOCK SYNTHESIZER (PHASE LOCK)
	17 110 MHz IF & 3rd CONVERTER		41 PROCESSOR
	18 VARIABLE RESOLUTION MOTHER BOARDS		42 MEMORY
	19 VR INPUT & 1st FILTER SELECT		43 ROM BANKS & GPIB
	19A 10 Hz/100 Hz BANDPASS FILTER		44 ACCESSORIES-INTERFACE
	20 10 dB GAIN, 20 dB GAIN, & BAND LEVELING		45 FRONT PANEL
	21 VR 2nd FILTER SELECT & POST AMPLIFIER		46 MAIN POWER SUPPLY (PRIMARY SECTION)
	22 LOG AMPLIFIER & DETECTOR		47 MAIN POWER SUPPLY (SECONDARY SECTION) & FAN DRIVE
	23 VIDEO AMPLIFIER	Section 11	48 MOTHER BOARD (FRONT)
			49 MOTHER BOARD (REAR)
			50 REFERENCE LOCK
			REPLACEABLE MECHANICAL PARTS

LIST OF ILLUSTRATIONS

The following figures are located near their associated diagrams in Section 10.

- | | | | |
|-------|---|-------|---|
| 10-1 | A16A1—1st LO Interface circuit board. | 10-32 | A68A8—VR 2nd Filter Select circuit board. |
| 10-2 | A18A1—2072 MHz 2nd Converter circuit board. | 10-33 | A68A9—VR Post Amplifier circuit board. |
| 10-3 | A22A1—16-20 MHz Phase Lock circuit board. | 10-34 | A62A1—Log Amplifier circuit board (front). |
| 10-4 | A22A2A1—2182 MHz Microstrip Osc. circuit board. | 10-35 | A62A1—Log Amplifier circuit board (rear). |
| 10-5 | A22A2A2—2200 MHz Reference circuit board. | 10-36 | A40—Video Processor circuit board. |
| 10-6 | A22A2A3—2200 MHz Reference Mixer circuit board. | 10-37 | A61A1—Vertical Digital Storage circuit board. |
| 10-7 | A23A1—719 MHz 2nd LO circuit board. | 10-38 | A60—Horizontal Digital Storage circuit board. |
| 10-8 | A23A2—25 MHz Phase Lock circuit board. | 10-39 | A64A1—Deflection Amplifiers circuit board. |
| 10-9 | A23A3—Harmonic Mixer circuit board. | 10-40 | A70—Z-Axis & RF Interface circuit board. |
| 10-10 | A23A4—829 MHz Diplexer circuit board. | 10-41 | A74—High Voltage circuit board. |
| 10-11 | A23A5—829 MHz Amplifier circuit board. | 10-42 | A66A1—CRT Readout circuit board. |
| 10-12 | A23A6—110 MHz IF Select circuit board. | 10-43 | A72—Sweep circuit board. |
| 10-13 | A23A7—829 MHz 2nd Converter circuit board. | 10-44 | A48A1—Span Attenuator circuit board. |
| 10-14 | A32A1—110 MHz IF Amplifier circuit board. | 10-45 | A44A1—1st LO Driver circuit board. |
| 10-15 | A34A1—100 MHz Osc. & 3rd Conv. circuit board. | 10-46 | A42A1—Preselector Driver circuit board. |
| 10-16 | A34A3A1—50/75 Ω Cal Out circuit board (Option 07). | 10-47 | A46A1—CF Control circuit board. |
| 10-17 | A19A1—110 MHz IF Out circuit board (Option 42). | 10-48 | A26A1—Auxiliary Synthesizer circuit board. |
| 10-18 | A68A1—VR Mother board #1. | 10-49 | A51A1—Counter circuit board. |
| 10-19 | A68A2—VR Mother board #2. | 10-50 | A50A1—Synthesizer circuit board. |
| 10-20 | A68A3—VR Input circuit board. | 10-51 | A50A2—Strobe Driver circuit board (front). |
| 10-21 | A68A4—VR 1st Filter Select circuit board. | 10-52 | A50A2—Strobe Driver circuit board (rear). |
| 10-22 | A69A1—1st Mixer circuit board (front) | 10-53 | A50A3—Offset Mixer circuit board. |
| 10-23 | A69A2—10 Hz/100 Hz Bandpass Filter
circuit board (front) | 10-54 | A50A4—Error Amplifier circuit board. |
| 10-24 | A69A3—2nd Mixer circuit board | 10-55 | A50A5—Controlled Oscillator circuit board. |
| 10-25 | A69A4—Local Oscillator circuit board (front) | 10-56 | A58—Processor circuit board. |
| 10-26 | A69A1—1st Mixer circuit board (rear) | 10-57 | A54—Memory circuit board. |
| 10-27 | A69A2—10 Hz/100 Hz Bandpass Filter
circuit board (rear) | 10-58 | A56—GPIB circuit board (front) |
| 10-28 | A69A4—Local Oscillator circuit board (rear) | 10-59 | A56—GPIB circuit board (rear). |
| 10-29 | A68A5—VR 10 dB Gain Steps circuit board. | 10-60 | A30A76—Accessories Interface circuit board. |
| 10-30 | A68A6—VR 20 dB Gain Steps circuit board. | 10-61 | A38—Front Panel circuit board. |
| 10-31 | A68A7—VR Band Leveling circuit board. | 10-62 | A30A1—Main Power Supply circuit board. |
| | | 10-63 | A30A2—Fan Drive circuit board. |
| | | 10-64 | A36A1—Reference Lock circuit board. |

SERVICING SAFETY SUMMARY

FOR QUALIFIED SERVICE PERSONNEL ONLY

Do Not Service Alone

Do not perform internal service or adjustment of this product unless another person capable of rendering first aid and resuscitation is present.

Do Not Wear Jewelry

Remove jewelry prior to servicing. Rings, necklaces, and other metallic objects could come into contact with dangerous voltages and currents.

Use Care When Servicing With Power On

Dangerous voltages exist at several points in this product. To avoid personal injury, do not touch exposed connections and components while power is on.

Disconnect power before removing protective panels, soldering, or replacing components.

Power Source

This product is intended to operate from a power source that will not apply more than 250 volts rms between the supply conductor and ground. A protective ground connection by way of the grounding conductor in the power cord is essential for safe operation.

X-Radiation

X-ray emission generated within this instrument has been sufficiently shielded. Do not modify or otherwise alter the high voltage circuitry or the crt enclosure.

TERMS

In This Manual

CAUTION statements identify conditions or practices that could result in damage to the equipment or other property.

WARNING statements identify conditions or practices that could result in personal injury or loss of life.

As Marked on Equipment

CAUTION indicates a personal injury hazard not immediately accessible as one reads the marking, or a hazard to property including the equipment itself.

DANGER indicates a personal injury hazard immediately accessible as one reads the marking.

SYMBOLS

In This Manual



This symbol indicates where applicable cautionary or other information is to be found.

As Marked on Equipment



DANGER — High Voltage.



Protective ground (earth) terminal.



ATTENTION — Refer to manual.



Refer to manual.

Grounding the Product

This product is grounded through the grounding conductor of the power cord. To avoid electrical shock, plug the power cord into a properly wired receptacle before connecting to the product input or output terminals. A protective ground connection by way of the grounding conductor in the power cord is essential for safe operation.

Danger Arising From Loss of Ground

Upon loss of the protective ground connection, all accessible conductive parts (including knobs and controls that may appear to be insulating) can render an electric shock.

Use the Proper Power Cord

Use only the power cord and connector specified for your product.

Use only a power cord that is in good condition.

For detailed information on power cords and connectors see Section 1.

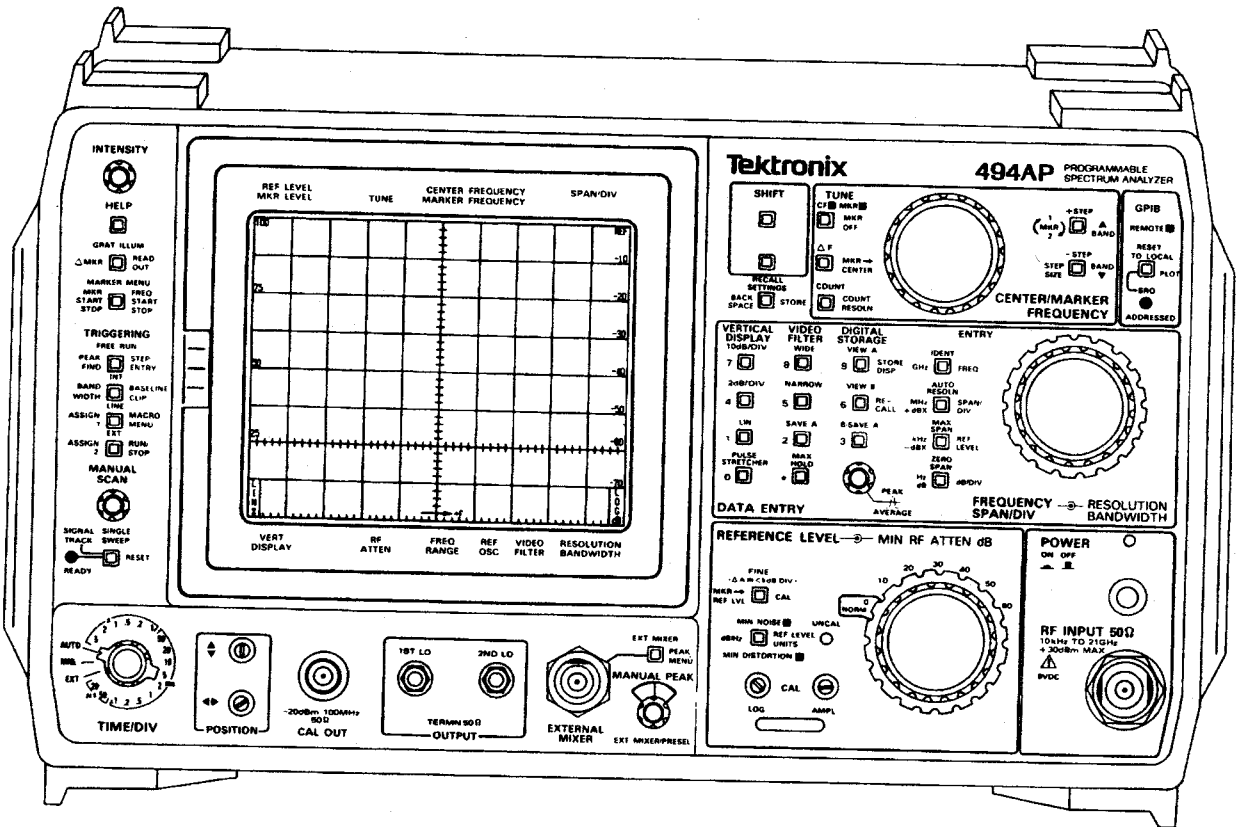

5557-01

The 494AP Spectrum Analyzer.

REPLACEABLE ELECTRICAL PARTS

PARTS ORDERING INFORMATION

Replacement parts are available from or through your local Tektronix, Inc. Field Office or representative.

Changes to Tektronix instruments are sometimes made to accommodate improved components as they become available, and to give you the benefit of the latest circuit improvements developed in our engineering department. It is therefore important, when ordering parts, to include the following information in your order: Part number, instrument type or number, serial number, and modification number if applicable.

If a part you have ordered has been replaced with a new or improved part, your local Tektronix, Inc. Field Office or representative will contact you concerning any change in part number.

Change information, if any, is located at the rear of this manual.

LIST OF ASSEMBLIES

A list of assemblies can be found at the beginning of the Electrical Parts List. The assemblies are listed in numerical order. When the complete component number of a part is known, this list will identify the assembly in which the part is located.

CROSS INDEX-MFR. CODE NUMBER TO MANUFACTURER

The Mfr. Code Number to Manufacturer index for the Electrical Parts List is located immediately after this page. The Cross Index provides codes, names and addresses of manufacturers of components listed in the Electrical Parts List.

ABBREVIATIONS

Abbreviations conform to American National Standard Y1.1.

COMPONENT NUMBER (column one of the Electrical Parts List)

A numbering method has been used to identify assemblies, subassemblies and parts. Examples of this numbering method and typical expansions are illustrated by the following:

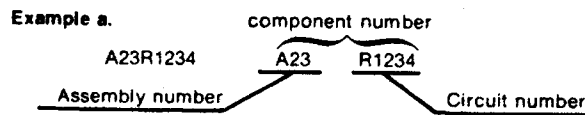

Read: Resistor 1234 of Assembly 23

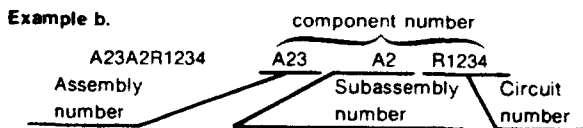

Read: Resistor 1234 of Subassembly 2 of Assembly 23

Only the circuit number will appear on the diagrams and circuit board illustrations. Each diagram and circuit board illustration is clearly marked with the assembly number. Assembly numbers are also marked on the mechanical exploded views located in the Mechanical Parts List. The component number is obtained by adding the assembly number prefix to the circuit number.

The Electrical Parts List is divided and arranged by assemblies in numerical sequence (e.g., assembly A1 with its subassemblies and parts, precedes assembly A2 with its subassemblies and parts).

Chassis-mounted parts have no assembly number prefix and are located at the end of the Electrical Parts List.

TEKTRONIX PART NO. (column two of the Electrical Parts List)

Indicates part number to be used when ordering replacement part from Tektronix.

SERIAL/MODEL NO. (columns three and four of the Electrical Parts List)

Column three (3) indicates the serial number at which the part was first used. Column four (4) indicates the serial number at which the part was removed. No serial number entered indicates part is good for all serial numbers.

NAME & DESCRIPTION (column five of the Electrical Parts List)

In the Parts List, an Item Name is separated from the description by a colon (:). Because of space limitations, an Item Name may sometimes appear as incomplete. For further Item Name identification, the U.S. Federal Cataloging Handbook H6-1 can be utilized where possible.

MFR. CODE (column six of the Electrical Parts List)

Indicates the code number of the actual manufacturer of the part. (Code to name and address cross reference can be found immediately after this page.)

MFR. PART NUMBER (column seven of the Electrical Parts List)

Indicates actual manufacturers part number.

CROSS INDEX - MFR. CODE NUMBER TO MANUFACTURER

Mfr. Code	Manufacturer	Address	City, State, Zip Code
00213	NYTRONICS COMPONENTS GROUP INC SUBSIDIARY OF NYTRONICS INC	ORANGE ST	DARLINGTON SC 29532
00681	MINE SAFETY APPLIANCE CO CATALYST RESEARCH DIV	1421 CLARKVIEW RD	BALTIMORE MD 21209-2103
00809	CROVEN CRYSTALS SUB OF ELECTRONIC TECHNOLOGIES INC	500 BEECH ST PO BOX 420	WHITBY ONT CAN L1N 5S5
01121	ALLEN-BRADLEY CO	1201 S 2ND ST	MILWAUKEE WI 53204-2410
01281	MOTOROLA INC RF & OPTOELECTRONIC PRODUCTS DIV	14520 AVIATION BLVD	LAWNDALE CA 90260-1121
01295	TEXAS INSTRUMENTS INC SEMICONDUCTOR GROUP	13500 N CENTRAL EXPY PO BOX 655012	DALLAS TX 75265
02111	HAMILTON STANDARD CONTROLS INC SPECTROL DIV	17070 E GALE AVE P O BOX 1220	CITY OF INDUSTRY CA 91749
02114	AMPEREX ELECTRONIC CORP FERROXCUBE DIV	5083 KINGS HWY	SAUGERTIES NY 12477
02735	RCA CORP SOLID STATE DIVISION		
04222	AVX CERAMICS DIV OF AVX CORP	19TH AVE SOUTH P O BOX 867	MYRTLE BEACH SC 29577
04713	MOTOROLA INC SEMICONDUCTOR PRODUCTS SECTOR	5005 E MCDOWELL RD	PHOENIX AZ 85008-4229
05397	UNION CARBIDE CORP MATERIALS SYSTEMS DIV	11901 MADISON AVE	CLEVELAND OH 44101
05828	GENERAL INSTRUMENT CORP GOVERNMENT SYSTEMS DIV	600 W JOHN ST	HICKSVILLE NY 11802
07088	KELVIN ELECTRIC CO	5907 NOBLE AVE	VAN NUYS CA 91411
07263	FAIRCHILD SEMICONDUCTOR CORP		
07716	TRW INC TRW IRC FIXED RESISTORS/BURLINGTON	2850 MT PLEASANT AVE	BURLINGTON IA 52601
11236	CTS CORP BERNE DIV	406 PARR ROAD	BERNE IN 46711-9506
11532	THICK FILM PRODUCTS GROUP TELEDYNE RELAYS	12525 DAPHNE AVE	HAWTHORNE CA 90250-3308
12954	TELEDYNE INDUSTRIES INC SUB OF TELEDYNE INC MICROSEMI CORP - SCOTTSDALE	8700 E THOMAS RD P O BOX 1390	SCOTTSDALE AZ 85252
12969	MICROSEMI CORPORATION WATERTOWN DIVISION	530 PLEASANT STREET	WATERTOWN MA 02172
14433	ITT SEMICONDUCTORS DIV		WEST PALM BEACH FL
14552	MICROSEMI CORP	2830 S FAIRVIEW ST	SANTA ANA CA 92704-5948
14752	ELECTRO CUBE INC	1710 S DEL MAR AVE	SAN GABRIEL CA 91776-3825
16179	M/A-COM OMNI SPECTRA INC MICROWAVE COMPONENT DIV SUB OF M/A-COM INC	21 CONTINENTAL BLVD	MERRIMACK NH 03054-4303
17540	ALPHA INDUSTRIES INC HQ/SEMICONDUCTOR DIV	20 SYLVAN RD PO BOX 1044	WOBURN MA 01801-1854
18324	SIGNETICS CORP MILITARY PRODUCTS DIV	4130 S MARKET COURT	SACRAMENTO CA 95834-1222
18612	VISHAY INTERTECHNOLOGY INC VISHAY RESISTOR PRODUCTS GROUP	63 LINCOLN HWY	MALVERN PA 19355-2120
19396	ILLINOIS TOOL WORKS INC PAKTRON DIV	1205 MCCONVILLE RD PO BOX 4539	LYNCHBURG VA 24502-4535
19701	PHILIPS COMPONENTS DISCRETE PRODUCTS DIV RESISTIVE PRODUCTS FACILITY	PO BOX 760	MINERAL WELLS TX 76067-0760
1F809	AIRPORT ROAD UNION CARBIDE CORP BATTERY PRODUCTS DIV	ONE CALIFORNIA	SAN FRANCISCO CA 94111
20932	KYOCERA INTERNATIONAL INC	11620 SORRENTO VALLEY RD PO BOX 81543 PLANT NO 1	SAN DIEGO CA 92121
22229	SOLITRON DEVICES INC SEMICONDUCTOR GROUP SAN DIEGO OPERS	8808 BALBOA AVE	SAN DIEGO CA 92123
24165	SPRAGUE ELECTRIC CO	267 LOWELL ROAD	HUDSON NH 03051
24355	ANALOG DEVICES INC	RT 1 INDUSTRIAL PK PO BOX 9106	NORWOOD MA 02062

CROSS INDEX - MFR. CODE NUMBER TO MANUFACTURER

Mfr. Code	Manufacturer	Address	City, State, Zip Code
24539	HEWLETT-PACKARD CO MICROWAVE SEMICONDUCTOR DIV/AVANTEK	3175 BOWERS AVE	SANTA CLARA CA 95051
24931	SPECIALTY CONNECTOR CO INC	2100 EARLYWOOD DR PO BOX 547	FRANKLIN IN 46131
25088	SIEMENS CORP	186 WOOD AVE S	ISELIN NJ 08830-2704
26769	MEPCO/CENTRALAB A NORTH AMERICAN PHILIPS CO	5900 AUSTRALIAN AVE	WEST PALM BEACH FL 33407-2330
26805	M/A-COM OMNI SPECTRA INC MICROWAVE CONNECTOR DIV SUB OF M/A-COM INC	140 4TH AVE	WALTHAM MA 02154-7507
27012	MICRO DEVICES CORP SUB OF EMERSON ELECTRIC CO	1320 S MAIN ST PO BOX 3538	MANSFIELD OH 44907-2516
27014	NATIONAL SEMICONDUCTOR CORP	2900 SEMICONDUCTOR DR	SANTA CLARA CA 95051-0606
28480	HEWLETT-PACKARD CO CORPORATE HQ	3000 HANOVER ST	PALO ALTO CA 94304-1112
29587	BUNKER RAMO CORP AMPHENOL INDUSTRIAL DIV	1830 S 54TH AVE	CHICAGO IL 60650
2M627	ROHM CORPORATION	PO BOX 19515	IRVINE CA 92713
31781	EDAC INC	20 RAILSIDE RD	DON MILLS ONT CAN M3A 1A4
32293	INTERSIL INC		
32997	BOURNS INC TRIMPOT DIV	1200 COLUMBIA AVE	RIVERSIDE CA 92507-2114
33095	SPECTRUM CONTROL INC	2185 W WEIGHT ST	ERIE PA 16505
33096	COLORADO CRYSTAL CORP	2303 W 8TH ST	LOVELAND CO 80537-5268
34335	ADVANCED MICRO DEVICES	901 THOMPSON PL	SUNNYVALE CA 94086-4518
34630	K AND L/QUARTZTEK INC	3940 W MONTECITO	PHOENIX AZ 85019
50101	FREQUENCY SOURCES INC SEMICONDUCTOR DIV SUB OF LORAL CORP	16 MAPLE RD	CHELMSFORD MA 01824-3737
50140	K AND L MICROWAVE INC SUB OF DOVER CORP	408 COLES CIR	SALISBURY MD 21801-3214
50434	HEWLETT-PACKARD CO OPTOELECTRONICS DIV	370 W TRIMBLE RD	SAN JOSE CA 95131
50438	HEWLETT-PACKARD CO DATA SYSTEMS DIV	11000 WOLFE RD	CUPERTINO CA 95014-0602
50558	ELECTRONIC CONCEPTS INC	526 INDUSTRIAL WAY W	EATONTOWN NJ 07724-2212
50667	DYNATECH MICROWAVE TECHNOLOGY INC DYNATECH MICROWAVE SWITCHES DIV	26655 W AGOURA RD	CLABASAS CA 91302-1921
51406	MURATA ERIE NORTH AMERICA INC HEADQUARTERS AND GEORGIA OPERATIONS	2200 LAKE PARK DR	SMYRNA GA 30080
51642	CENTRE ENGINEERING INC	2820 E COLLEGE AVE	STATE COLLEGE PA 16801-7515
52763	STETCO INC	3344 SCHIERHORN	FRANKLIN PARK IL 60131
53387	MINNESOTA MINING MFG CO	PO BOX 2963	AUSTIN TX 78769-2963
54473	MATSUSHITA ELECTRIC CORP OF AMERICA	ONE PANASONIC WAY PO BOX 1501	SECAUCUS NJ 07094-2917
54583	TDK ELECTRONICS CORP	12 HARBOR PARK DR	PORT WASHINGTON NY 11550
55680	NICHICON /AMERICA/ CORP	927 E STATE PKY	SCHAUMBURG IL 60195-4526
57668	ROHM CORP	8 WHATNEY PO BOX 19515	IRVINE CA 92713
57688	GANAR INDUSTRIES INC	13721 HARVARD PL	GARDENA CA 90249-2527
58361	QUALITY TECHNOLOGIES CORP	3400 HILLVIEW AVE	PALO ALTO CA 94304-1319
58854	GTE PRODUCTS CORP LIGHTING PRODUCTS GROUP		
59492	K AND L QUARTZTEK DIV OF K AND L MICROWAVE INC		
59660	TUSONIX INC	7741 N BUSINESS PARK DR PO BOX 37144	TUCSON AZ 85740-7144
71400	BUSSMANN DIV OF COOPER INDUSTRIES INC	114 OLD STATE RD PO BOX 14460	ST LOUIS MO 63178
71468	ITT CANNON DIV OF ITT CORP	666 E DYER RD	SANTA ANA CA 92702
71744	CHICAGO MINIATURE LAMP INC	CHEVY CHASE BUSINESS PARK 1080 JOHNSON DRIVE	BUFFALO GROVE IL 60089
72982	ERIE SPECIALTY PRODUCTS INC	645 W 11TH ST	ERIE PA 16512

CROSS INDEX - MFR. CODE NUMBER TO MANUFACTURER

Mfr. Code	Manufacturer	Address	City, State, Zip Code
75042	IRC ELECTRONIC COMPONENTS PHILADELPHIA DIV TRW FIXED RESISTORS	401 N BROAD ST	PHILADELPHIA PA 19108-1001
75378	CTS KNIGHTS INC	400 REIMANN AVE	SANDWICH IL 60548-1846
75915	LITTELFUSE INC SUB TRACOR INC	800 E NORTHWEST HWY	DES PLAINES IL 60016-3049
76493	BELL INDUSTRIES INC JW MILLER DIV	19070 REYES AVE PO BOX 5825	COMPTON CA 90224-5825
80009	TEKTRONIX INC	14150 SW KARL BRAUN DR PO BOX 500	BEAVERTON OR 97077-0001
81073	GRAYHILL INC	561 HILLGROVE AVE PO BOX 10373	LA GRANGE IL 60525-5914
84411	AMERICAN SHIZUKI CORP OGALLALA OPERATIONS	301 WEST O ST	OGALLALA NE 69153-1844
87473	INSULLECTRO A DIV OF QUINTEC INDUSTRIES	3176 AIRWAY AVE	COSTA MESA CA 92626-4608
91506	AUGAT INC	33 PERRY AVE P O BOX 779	ATTLEBORO MA 02703-2417
91637	DALE ELECTRONICS INC	2064 12TH AVE PO BOX 609	COLUMBUS NE 68601-3632
95275	VITRAMON INC	BOX 544	BRIDGEPORT CT 06601-0544
98821	NORTH HILLS ELECTRONICS INC	ALXNDR PL	GLEN COVE NY 11542-3704
S0545	NIPPON ELECTRIC CO LTD		TOKYO JAPAN
TK0146	BUEHLER PRODUCTS INC	PO BOX A HIGHWAY 70	EAST KINSTON NC 28501
TK0510	PANASONIC COMPANY DIV OF MATSUSHITA ELECTRIC CORP	ONE PANASONIC WAY	SECAUCUS NJ 07094
TK0858	STAUFFER SUPPLY CO (DIST)		
TK0900	UNITED CHEMICON		
TK0935	MARQUARDT SWITCHES INC		
TK0961	NEC ELECTRONICS USA INC		
TK1134	TUSONIX INC	2155 N FORBES BLVD	TUCSON AZ 85705
TK1345	ZMAN & ASSOCIATES		
TK1375	ESAM		
TK1409	AMERICAN PRECISION INDUSTRIES INC		
TK1421	COILTRON	PO BOX 904	BEAVERTON OR 97075
TK1424	MARCON AMERICA CORP		
TK1468	LINEAR TECHNOLOGY CORP	1630 MCCARTHY BLVD	MILPITAS CA 95037
TK1727	PHILIPS NEDERLAND BV AFD ELONCO	POSTBUS 90050	5600 PB EINDHOVEN THE NETHERLANDS
TK2469	UNITREK CORPORATION	3000 LEWIS & CLARK WAY SUITE #2	VANCOUVER WA 98601

Replaceable Electrical Parts
494A/494AP Service Vol.2

Component No.	Tektronix Part No.	Serial/Assembly No. Effective	Dscont	Name & Description	Mfr. Code	Mfr. Part No.
AT10	119-1007-07	B010100	B020683	ATTENUATOR,VAR:0-60DB IN 10DB STEPS	50667	ORDER BY DESCR
AT10	119-1007-09	B020684		ATTENUATOR:0-60DB IN 10DB STEPS	80009	119-1007-09
AT11	015-1053-01			ATTENUATOR,FXD:3DB PAD	16179	2082-4287-03
AT12	015-1053-01			ATTENUATOR,FXD:3DB PAD	16179	2082-4287-03
A10	119-1061-00	B010100	B010438	LIMITER ASSY:2GHZ	80009	119-1061-00
A10	119-1061-01	B010439		LIMITER ASSY:2GHZ	80009	119-1061-01
A11	119-1164-00			BIAS RETURN:	80009	119-1164-00
A12	119-1017-01			FIRST CONV ASSY:	80009	119-1017-01
A12A1	155-0189-02			MICROCKT,LINER:DUAL DIODE W/HOUSING	80009	155-0189-02
A13	119-1019-00			POWER DIV ASSY:	80009	119-1019-00
A14	119-1645-01			DIPLEXER ASSY:	80009	119-1645-01
A16	119-0752-02			OSCILLATOR,RF:2.0 TO 6.1 GHZ W/CAN	80009	119-0752-02
A16A1	670-5540-00			CIRCUIT BD ASSY:1ST L O INTERFACE	80009	670-5540-00
A17	015-1053-01	B010220		ATTENUATOR,FXD:3DB PAD	16179	2082-4287-03
A18	119-1096-02	B010100	B020696	SEC CONV ASSY:	80009	119-1096-02
A18	119-1096-03	B020697		SEC CONV ASSY:494AP	80009	119-1096-03
A18A1	-----			CKT BOARD ASSY:2ND CONVERTER (PART OF A18)		
A19	119-1845-02	B010100	B010113	110MHZ IF ASSY: (OPTION 42 ONLY)	80009	119-1845-02
A19	119-1845-03	B010114		110MHZ IF ASSY: (OPTION 42 ONLY)	80009	119-1845-03
A19A1	670-8650-02	B010100	B010113	CIRCUIT BD ASSY:110MHZ IF OUT (OPTION 42 ONLY)	80009	670-8650-02
A19A1	670-8650-03	B010114		CIRCUIT BD ASSY:110MHZ IF OUT (OPTION 42 ONLY)	80009	670-8650-03
A22	650-0736-01	B010100	B010232	PH LOCK 2ND LO:	80009	650-0736-01
A22	650-0736-02	B010233		PHASE LOCK ASSY:	80009	650-0736-02
A22A1	670-7914-00			CIRCUIT BD ASSY:16-20MHZ PHASELOCK	80009	670-7914-00
A22A2	-----			(PART OF A22)		
A22A2A1	670-7395-01			CIRCUIT BD ASSY:2182MHZ MICRO STRIP OSC	80009	670-7395-01
A22A2A2	670-7076-01			CIRCUIT BD ASSY:2200MHZ REF	80009	670-7076-01
A22A2A3	670-7079-00			CIRCUIT BD ASSY:2200MHZ REFERENCE MIXER	80009	670-7079-00
A23	119-1131-05			SEC CONN ASSY:829MHZ	80009	119-1131-05
A23A1	670-5936-00			CIRCUIT BD ASSY:719MHZ SECOND LO	80009	670-5936-00
A23A2	670-5937-03			CIRCUIT BD ASSY:25MHZ PHASE LOCK	80009	670-5937-03
A23A3	670-6016-00			CIRCUIT BD ASSY:829MHZ HARMONIC MIXER	80009	670-6016-00
A23A4	670-6256-03			CIRCUIT BD ASSY:829MHZ DIPLEXER	80009	670-6256-03
A23A5	670-6255-01			CIRCUIT BD ASSY:829MHZ AMPL	80009	670-6255-01
A23A6	670-6015-01			CIRCUIT BD ASSY:110MHZ IF SELECT	80009	670-6015-01
A23A7	670-6224-00			CIRCUIT BD ASSY:829MHZ,SECOND CONVERTER	80009	670-6224-00
A24	119-1010-02			HYBRID CKT ASSY:PHASE GATE DETECTOR	80009	119-1010-02
A24A1	670-5957-01			CIRCUIT BD ASSY:PHASE GATE INPUT	80009	670-5957-01
A25	119-1640-01	B010100	B020706	HARMONIC MIXER:	80009	119-1640-01
A25	119-1640-02	B020707		HARMONIC MIXER:494AP	80009	119-1640-02
A25A3	670-4376-01	B010100	B020668	CIRCUIT BD ASSY:HARMONIC MIXER INPUT	80009	670-4376-01
A25A3	670-5957-01	B020668		CIRCUIT BD ASSY:PHASE GATE INPUT	80009	670-5957-01
A26	672-0160-00			CIRCUIT BD ASSY:AUX SYNTHESIZER	80009	672-0160-00
A26A1	670-9163-00			CIRCUIT BD ASSY:AUX SYNTH	80009	670-9163-00
A28	670-7920-01			CIRCUIT BD ASSY:MAIN MOTHER	80009	670-7920-01
A30	621-0023-00	B010100	B010249	POWER SUPPLY:	80009	621-0023-00
A30	621-0023-01	B010250		POWER SUPPLY: (494A ONLY)	80009	621-0023-01
A30	621-0024-00	B010100	B010249	POWER SUPPLY:	80009	621-0024-00
A30	621-0024-01	B010250		POWER SUPPLY: (494AP ONLY)	80009	621-0024-01
A30	621-0030-00	B010100	B010249	POWER SUPPLY:	80009	621-0030-00
A30	621-0030-01	B010250		POWER SUPPLY: (494A OPTION 42 ONLY)	80009	621-0030-01

Replaceable Electrical Parts
494A/494AP Service Vol.2

Component No.	Tektronix Part No.	Serial/Assembly No. Effective	Dscont	Name & Description	Mfr. Code	Mfr. Part No.
A30	621-0031-00	B010100	B010249	POWER SUPPLY:	80009	621-0031-00
A30	621-0031-01	B010250		POWER SUPPLY: (494AP OPTION 42 ONLY)	80009	621-0031-01
A30A1	670-8036-01	B010100	B010249	CIRCUIT BD ASSY:PWR SPLY	80009	670-8036-01
A30A1	670-8036-04	B010250		CIRCUIT BD ASSY:PWR SPLY	80009	670-8036-04
A30A2	670-7226-00			CIRCUIT BD ASSY:FAN DRIVE	80009	670-7226-00
A30A57	670-9841-00			CIRCUIT BD ASSY:GPIB INTERFACE (494A ONLY)	80009	670-9841-00
A30A57	670-9806-00			CIRCUIT BD ASSY:GPIB INTERFACE (494AP ONLY)	80009	670-9806-00
A30A76	670-5558-02			CIRCUIT BD ASSY:ACCESSORIES INTERFACE;;388-6085-XX WIRED	80009	670-5558-02
A32	119-1015-00	B010100	B010221	FILTER,AMPL:110MHZ	80009	119-1015-00
A32	119-1015-01	B010222		FILTER AMPL:110MHZ	80009	119-1015-01
A32A1	-----			CKT BOARD ASSY:110 IF (PART OF A32)		
A34	119-1579-01			OSC/MIXER ASSY:3RD CONVERTER	80009	119-1579-01
A34A1	-----			CKT BOARD ASSY:3RD CONVERTER (PART OF A34)		
A34A2	-----			CIRCUIT BD ASSY:100MHZ OSC REGULATOR (PART OF A34)		
A34A3	119-1905-01			RELAY ASSEMBLY: (OPTION 07 ONLY)	80009	119-1905-01
A34A3A1	670-8491-01			CIRCUIT BD ASSY:RELAY (OPTION 07 ONLY)	80009	670-8491-01
A36	119-1588-02			PH LOCK 3RD LO:	80009	119-1588-02
A36A1	-----			CKT BOARD ASSY:REFERENCE LOCK		
A36A2	670-7917-01			CIRCUIT BD ASSY:REFERENCE LOCK REGULATOR	80009	670-7917-01
A37	119-1576-01			OSCILLATOR,RF:10.000MHZ,CRYSTAL	80009	119-1576-01
A38	670-7947-03			CIRCUIT BD ASSY:FRONT PNL	80009	670-7947-03
A40	670-8389-01			CIRCUIT BD ASSY:VIDEO PROCESSOR	80009	670-8389-01
A42	672-0166-01			CIRCUIT BD ASSY:PRESELECTOR DRIVER	80009	672-0166-01
A42A1	670-5552-05			CIRCUIT BD ASSY:PRESELECTOR DRIVER	80009	670-5552-05
A44	672-0158-00			CIRCUIT BD ASSY:1ST LO DRIVER	80009	672-0158-00
A44A1	670-9051-00			CIRCUIT BD ASSY:1ST LO DRIVER	80009	670-9051-00
A46	672-0165-00			CIRCUIT BD ASSY:CENTER FREQ CONTROL	80009	672-0165-00
A46A1	670-9094-01			CIRCUIT BD ASSY:CENTER FREQ CONT	80009	670-9094-01
A48	672-0157-00			CIRCUIT BD ASSY:SPAN ATTENUATOR	80009	672-0157-00
A48A1	670-5550-01			CIRCUIT BD ASSY:SPAN ATTENUATOR	80009	670-5550-01
A50	119-1992-02	B010100	B010476	PHASE LOCK ASSY:	80009	119-1992-02
A50	119-1992-03	B010477		PHASE LOCK ASSY:	80009	119-1992-03
A50A1	670-5519-01			CIRCUIT BD ASSY:SYNTHESIZER	80009	670-5519-01
A50A2	670-9068-00			CIRCUIT BD ASSY:STROBE DRIVER	80009	670-9068-00
A50A3	670-5522-02			CIRCUIT BD ASSY:OFFSET MIXER	80009	670-5522-02
A50A4	670-7921-03			CIRCUIT BD ASSY:ERROR AMPL	80009	670-7921-03
A50A5	670-5524-02	B010100	B010476	CIRCUIT BD ASSY:CONTROLLED OSC	80009	670-5524-02
A50A5	670-5524-03	B010477		CIRCUIT BD ASSY:CONTROLLED OSC	80009	670-5524-03
A51	672-0164-00			CIRCUIT BD ASSY:COUNTER	80009	672-0164-00
A51A1	670-7899-01			CIRCUIT BD ASSY:COUNTER	80009	670-7899-01
A54	670-9680-00	B010100	B010164	CIRCUIT BD ASSY:MEMORY	80009	670-9680-00
A54	670-9680-01	B010165	B010216	CIRCUIT BD ASSY:MEMORY	80009	670-9680-01
A54	670-9680-02	B010217	B020700	CIRCUIT BD ASSY:MEMORY	80009	670-9680-02
A54	671-2124-00	B020701		CIRCUIT BD ASSY:MEMORY;;388-9200-XX WIRED	80009	671-2124-00
A54	670-9950-00	B010100	B010215	CIRCUIT BD ASSY:MEMORY	80009	670-9950-00
A54	670-9950-01	B010216	B010216	CIRCUIT BD ASSY:MEMORY	80009	670-9950-01
A54	670-9950-02	B010217	B010238	CIRCUIT BD ASSY:MEMORY (OPTION 39 ONLY)	80009	670-9950-02
A54	671-2125-00	B010239		CIRCUIT BD ASSY:MEMORY;;388-9200-XX WIRED,0 PT 39	80009	671-2125-00
A54	671-0029-00	B010100	B010502	CIRCUIT BD ASSY:MEMORY	80009	671-0029-00

Replaceable Electrical Parts
494A/494AP Service Vol.2

Component No.	Tektronix Part No.	Serial/Assembly No. Effective	Dscont	Name & Description	Mfr. Code	Mfr. Part No.
A54	671-0029-01	B010503		CIRCUIT BD ASSY:MEMORY (OPTION 45 ONLY)	80009	671-0029-01
A56	670-9770-00	B010100	B010215	CIRCUIT BD ASSY:GPIB	80009	670-9770-00
A56	670-9770-01	B010216	B010216	CIRCUIT BD ASSY:GPIB	80009	670-9770-01
A56	670-9770-02	B010217	B020700	CIRCUIT BD ASSY:GPIB	80009	670-9770-02
A56	671-2123-00	B020701	B020764	CIRCUIT BD ASSY:GPIB;;388-9263-XX WIRED	80009	671-2123-00
A56	671-2123-01	B020765		CIRCUIT BD ASSY:GPIB;;388-9263-XX WIRED	80009	671-2123-01
A56	671-0030-00	B010100	B010502	CIRCUIT BD ASSY:GPIB	80009	671-0030-00
A56	671-0030-01	B010503	B020764	CIRCUIT BD ASSY:GPIB	80009	671-0030-01
A56	671-0030-02	B020765		CIRCUIT BD ASSY:GPIB;;388-9263-XX WIRED (OPTION 45 ONLY)	80009	671-0030-02
A58	670-8882-00	B010100	B020771	CIRCUIT BD ASSY:PROCESSOR	80009	670-8882-00
A58	670-8882-01	B020772		CKT BD SUBASSY:PROCESSOR;;388-0333-XX WIRED	80009	670-8882-01
A60	670-9100-02			CIRCUIT BD ASSY:DIGITAL STORAGE INTERFACE	80009	670-9100-02
A61	672-0163-01			CIRCUIT BD ASSY:VERTICAL DIGITAL STORAGE	80009	672-0163-01
A61A1	670-9099-01			CIRCUIT BD ASSY:DIGITAL STORAGE	80009	670-9099-01
A62	672-0187-00			CIRCUIT BD ASSY:LOG AMP	80009	672-0187-00
A62A1	670-9091-00			CIRCUIT BD ASSY:LOG AMP	80009	670-9091-00
A64	672-0162-01	B010100	B010134	CIRCUIT BD ASSY:DEFL AMP	80009	672-0162-01
A64	672-0162-02	B010135		CIRCUIT BD ASSY:DEFL AMP	80009	672-0162-02
A64A1	670-8083-01	B010100	B010134	CIRCUIT BD ASSY:DEFLECTION AMP	80009	670-8083-01
A64A1	670-8083-02	B010135		CIRCUIT BD ASSY:DEFL AMP	80009	670-8083-02
A66	672-0159-00			CIRCUIT BD ASSY:CRT READOUT	80009	672-0159-00
A66A1	670-7902-00			CIRCUIT BD ASSY:CRT READOUT	80009	670-7902-00
A68	644-0645-00	B010100	B010181	VR MODULE ASSY:.	80009	644-0645-00
A68	644-0645-02	B010182	B010389	VR MODULE ASSY:	80009	644-0645-02
A68	644-0645-03	B010390		VAR RESOLN MDL:495/P	80009	644-0645-03
A68	644-0675-00	B010100	B010181	VR MODULAR ASSY:	80009	644-0675-00
A68	644-0675-01	B010182	B010389	VR MODULE ASSY:	80009	644-0675-01
A68	644-0675-02	B010390		VAR RESOLN MDL:494/AP (OPTION 07 ONLY)	80009	644-0675-02
A68A1	670-5528-03			CIRCUIT BD ASSY:#1VR MOTHER	80009	670-5528-03
A68A2	670-5536-04	B010100	B010389	CIRCUIT BD ASSY:#2 V.R. MOTHER	80009	670-5536-04
A68A2	670-5536-05	B010390		CIRCUIT BD ASSY:#2 V.R. MOTHER	80009	670-5536-05
A68A3	670-9843-00			CIRCUIT BD ASSY:VR INPUT	80009	670-9843-00
A68A4	670-9531-00			CIRCUIT BD ASSY:1ST FILTER SELECT	80009	670-9531-00
A68A4	670-9951-00			CIRCUIT BD ASSY:1ST FILTER SELECT (OPTION 07 ONLY)	80009	670-9951-00
A68A5	670-8321-00			CIRCUIT BD ASSY:10DB GAIN STEPS	80009	670-8321-00
A68A6	670-5532-04			CIRCUIT BD ASSY:20DB GAIN STEPS	80009	670-5532-04
A68A7	670-5533-03			CIRCUIT BD ASSY:BAND LEVELING	80009	670-5533-03
A68A8	671-0094-00	B010100	B010181	CIRCUIT BD ASSY:2ND FILTER SELECT	80009	671-0094-00
A68A8	671-0094-01	B010182		CIRCUIT BD ASSY:2ND FILTER SELECT	80009	671-0094-01
A68A8	670-9598-01			CIRCUIT BD ASSY:2ND FILTER SELECT (OPTION 07 ONLY)	80009	670-9598-01
A68A9	670-9778-00			CIRCUIT BD ASSY:POST VR AMPLIFIER	80009	670-9778-00
A69	119-2502-00	B010100	B010181	FILTER,DUAL BW:100HZ	80009	119-2502-00
A69	119-2502-01	B010182		FILTER,DUAL BW:100HZ	80009	119-2502-01
A69A1	670-9948-00	B010100	B010181	CIRCUIT BD ASSY:1ST MIXER	80009	670-9948-00
A69A1	670-9948-02	B010182		CIRCUIT BD ASSY:1ST MIXER	80009	670-9948-02
A69A2	670-9949-00	B010100	B010181	CIRCUIT BD ASSY:BAND PASS FILTER	80009	670-9949-00
A69A2	670-9949-01	B010182		CIRCUIT BD ASSY:BAND PASS FILTER	80009	670-9949-01
A69A2A1	670-6067-00			CIRCUIT BD ASSY:CRYSTAL HOLDER	80009	670-6067-00
A69A2A2	670-6067-00			CIRCUIT BD ASSY:CRYSTAL HOLDER	80009	670-6067-00
A69A2A3	670-6067-00			CIRCUIT BD ASSY:CRYSTAL HOLDER	80009	670-6067-00
A69A3	670-9946-00			CIRCUIT BD ASSY:2ND MIXER	80009	670-9946-00
A69A4	670-9947-00			CIRCUIT BD ASSY:LOCAL OSCILLATOR	80009	670-9947-00
A70	670-9932-00	B010100	B010273	CIRCUIT BD ASSY:Z-AXIS	80009	670-9932-00
A70	670-9932-01	B010274	B020742	CIRCUIT BD ASSY:Z-AXIS	80009	670-9932-01

Replaceable Electrical Parts
494A/494AP Service Vol.2

Component No.	Tektronix Part No.	Serial/Assembly No. Effective	Discont	Name & Description	Mfr. Code	Mfr. Part No.
A70	670-9932-02	B020743		CIRCUIT BD ASSY:Z-AXIS;;388-9404-XX WIRED	80009	670-9932-02
A72	670-9090-04			CIRCUIT BD ASSY:SWEEP	80009	670-9090-04
A74	670-5559-06	B010100	B010219	CIRCUIT BD ASSY:HIG VOLTAGE	80009	670-5559-06
A74	670-5559-07	B010220		CIRCUIT BD ASSY:HIG VOLTAGE	80009	670-5559-07
A74A1	-----			(PART OF A74)		
A77	670-5746-01			CIRCUIT BD ASSY:CRT GRATICULE LIGHT	80009	670-5746-01
AT10	119-1007-07			ATTENUATOR,VAR:0-60DB IN 10DB STEPS	50667	ORDER BY DESCR
AT11	015-1053-00			ATTENUATOR,FXD:3DB	26805	2082-4182-03
AT10	119-1007-07	B010100	B020683	ATTENUATOR,VAR:0-60DB IN 10DB STEPS	50667	ORDER BY DESCR
AT10	119-1007-09	B020684		ATTENUATOR:0-60DB IN 10DB STEPS	80009	119-1007-09
AT11	015-1053-01			ATTENUATOR,FXD:3DB PAD	16179	2082-4287-03
AT12	015-1053-01			ATTENUATOR,FXD:3DB PAD	16179	2082-4287-03
A10	119-1061-00	B010100	B010438	LIMITER ASSY:2GHZ	80009	119-1061-00
A10	119-1061-01	B010439		LIMITER ASSY:2GHZ	80009	119-1061-01
A11	119-1164-00			BIAS RETURN:	80009	119-1164-00
A12	119-1017-01			FIRST CONV ASSY:	80009	119-1017-01
A12A1	155-0189-02			MICROCKT,LINEAR:DUAL DIODE W/HOUSING	80009	155-0189-02
A13	119-1019-00			POWER DIV ASSY:	80009	119-1019-00
A14	119-1645-01			DIPLEXER ASSY:	80009	119-1645-01
A16	119-0752-02			OSCILLATOR,RF:2.0 TO 6.1 GHZ W/CAN	80009	119-0752-02
A16C1013	290-0778-00			CAP,FXD,ELCTLT:1UF,20%,50V,NPLZD	54473	ECE-A50N1
A16A1	670-5540-00			CIRCUIT BD ASSY:1ST L O INTERFACE	80009	670-5540-00
A16A1C1012	290-0326-02			CAP,FXD,ELCTLT:820UF,10%,6V	24165	109D827X9006F2
A16A1C1014	290-0326-02			CAP,FXD,ELCTLT:820UF,10%,6V	24165	109D827X9006F2
A16A1C1016	290-0529-00			CAP,FXD,ELCTLT:47UF,20%,20V	80009	290-0529-00
A16A1K1015	148-0076-00			RLY,REED:FRM A,250MA,100V,COIL.5V,500 OHM	80009	148-0076-00
A16A1L1011	108-0205-00			COIL,RF:FIXED,1MH	76493	8209
A16A1VR1010	152-0590-00			DIODE,ZENER:.;18V,5%,0.4W;1N967B,DO-35 OR 7	80009	152-0590-00
				,TR		
A16A1VR1018	152-0304-00			DIODE,ZENER:.;20V,5%,0.4W;1N968B,DO-35 OR 7	80009	152-0304-00
				,TR		
A16A1VR1019	152-0304-00			DIODE,ZENER:.;20V,5%,0.4W;1N968B,DO-35 OR 7	80009	152-0304-00
				,TR		
A17	015-1053-01	B010220		ATTENUATOR,FXD:3DB PAD	16179	2082-4287-03
A18	119-1096-02	B010100	B020696	SEC CONV ASSY:	80009	119-1096-02
A18	119-1096-03	B020697		SEC CONV ASSY:494AP	80009	119-1096-03
A18W140	175-2199-02			CABLE ASSY,RF:50 OHM COAX,13.04 L	80009	175-2199-02
A18W222	175-3849-01			CABLE ASSY,RF:50 OHM COAX,4.85 L	80009	175-3849-01
A18A1	-----			CKT BOARD ASSY:2ND CONVERTER		
				(PART OF A18)		
A18A1U1014	156-0158-00			IC,LINEAR:BIPOLAR,OP-AMP;DUAL;MC1458P1,DIP0	80009	156-0158-00
				8.3		
A19	119-1845-02	B010100	B010113	110MHZ IF ASSY:	80009	119-1845-02
				(OPTION 42 ONLY)		
A19	119-1845-03	B010114		110MHZ IF ASSY:	80009	119-1845-03
				(OPTION 42 ONLY)		
A19C190	281-0825-00			CAP,FXD,CER DI:0.005UF,+100-0%,100V	33095	51-726-008
A19A1	670-8650-02	B010100	B010113	CIRCUIT BD ASSY:110MHZ IF OUT	80009	670-8650-02
				(OPTION 42 ONLY)		
A19A1	670-8650-03	B010114		CIRCUIT BD ASSY:110MHZ IF OUT	80009	670-8650-03
				(OPTION 42 ONLY)		
A19A1C10	283-5008-00			CAP,FXD,CER DI:12PF,5%,50V	54583	C3216COG1H120J
A19A1C12	283-5009-00			CAP,FXD,CER DI:15PF,5%,50V	54583	C3216COG1H150J
A19A1C14	281-0267-00			CAP,VAR,CERAMIC:6-50PF,50V	80009	281-0267-00
A19A1C16	283-5005-00			CAP,FXD,CER DI:4PF,+/- 0.25PF,50V	54583	C3216COG1H040C
A19A1C18	283-5009-00			CAP,FXD,CER DI:15PF,5%,50V	54583	C3216COG1H150J
A19A1C20	281-0267-00			CAP,VAR,CERAMIC:6-50PF,50V	80009	281-0267-00
A19A1C22	283-5006-00			CAP,FXD,CER DI:5PF,+/- 0.25PF,50V	54583	C3216COG1H050C

Replaceable Electrical Parts
494A/494AP Service Vol.2

Component No.	Tektronix Part No.	Serial/Assembly No.		Name & Description	Mfr. Code	Mfr. Part No.
		Effective	Discont			
A19A1C24	283-5009-00			CAP,FXD,CER DI:15PF,5%,50V	54583	C3216C0G1H150J
A19A1C26	281-0267-00			CAP,VAR,CERAMIC:6-50PF,50V	80009	281-0267-00
A19A1C28	283-5007-00			CAP,FXD,CER DI:8PF,+/- 0.5PF,50V	80009	283-5007-00
A19A1L10	108-0606-00			COIL,RF:	80009	108-0606-00
A19A1L11	108-0262-00	B010114		COIL,RF:FIXED,505NH	80009	108-0262-00
A19A1L12	108-0606-00			COIL,RF:	80009	108-0606-00
A19A1L14	108-0606-00			COIL,RF:	80009	108-0606-00
A19A1R10	321-5043-00			RES,FXD,FILM:47.5 OHM,1%,0.125W	80009	321-5043-00
A19A1R12	321-5006-00	B010100	B010113	RES,FXD,FILM:100 OHM,1%,0.125W	80009	321-5006-00
A19A1R12	321-5046-00	B010114		RES,FXD,FILM:82.5 OHM,1%,0.125W	80009	321-5046-00
A19A1R14	321-5045-00	B010100	B010113	RES,FXD,FILM:68.1 OHM,1%,0.125W	80009	321-5045-00
A19A1R14	321-5046-00	B010114		RES,FXD,FILM:82.5 OHM,1%,0.125W	80009	321-5046-00
A19A1R16	321-5006-00	B010100	B010113	RES,FXD,FILM:100 OHM,1%,0.125W	80009	321-5006-00
A19A1R16	321-5046-00	B010114		RES,FXD,FILM:82.5 OHM,1%,0.125W	80009	321-5046-00
A19A1R18	315-0391-00			RES,FXD,FILM:390 OHM,5%,0.25W	80009	315-0391-00
A19A1T10	120-1567-00			XFMR,COUPLER:BALUN	TK1421	ORDER BY DESCR
A19A1T11	120-1760-00	B010114		TRANSFORMER,RF:BIFILAR,2 TURN	80009	120-1760-00
A19A1T12	120-1567-00			XFMR,COUPLER:BALUN	TK1421	ORDER BY DESCR
A19A1T13	120-1760-00	B010114		TRANSFORMER,RF:BIFILAR,2 TURN	80009	120-1760-00
A19A1T15	120-1760-00	B010114		TRANSFORMER,RF:BIFILAR,2 TURN	80009	120-1760-00
A19A1U10	156-2247-00			MICROCKT,LINEAR:GENERAL PURPOSE AMP MODULE	24539	GPD-1003A
A19A1U12	156-2208-00			IC,LINEAR:BIPOLAR,AMPLIFIER:MICROWAVE,5-200 MHZ,15DB GAIN,HYBRID;GPD252,TO-12	24539	GPD-252A
A19A1U14	156-2208-00			IC,LINEAR:BIPOLAR,AMPLIFIER:MICROWAVE,5-200 MHZ,15DB GAIN,HYBRID;GPD252,TO-12	24539	GPD-252A
A22	650-0736-01	B010100	B010232	PH LOCK 2ND LO.	80009	650-0736-01
A22	650-0736-02	B010233		PHASE LOCK ASSY:	80009	650-0736-02
A22C220	281-0720-00			CAP,FXD,CER DI:1750PF,+80-20%,250V	33095	51-707-002
A22C221	281-0720-00			CAP,FXD,CER DI:1750PF,+80-20%,250V	33095	51-707-002
A22C222	281-0720-00			CAP,FXD,CER DI:1750PF,+80-20%,250V	33095	51-707-002
A22C223	281-0720-00			CAP,FXD,CER DI:1750PF,+80-20%,250V	33095	51-707-002
A22C224	281-0720-00			CAP,FXD,CER DI:1750PF,+80-20%,250V	33095	51-707-002
A22C226	281-0720-00			CAP,FXD,CER DI:1750PF,+80-20%,250V	33095	51-707-002
A22C227	281-0720-00			CAP,FXD,CER DI:1750PF,+80-20%,250V	33095	51-707-002
A22L1060	108-0182-00	B010233		COIL,RF:FIXED,293NH	80009	108-0182-00
A22R224	321-0189-00			RES,FXD,FILM:909 OHM,1%,0.125W,TC=TO	80009	321-0189-00
A22W1048	175-8791-00			CA ASSY,SP,ELEC:8,26 AWG,7.5 L,RIBBON	TK1375	175-8791-00
A22A1	670-7914-00			CIRCUIT BD ASSY:16-20MHZ PHASELOCK	80009	670-7914-00
A22A1C1012	290-0517-00			CAP,FXD,ELCTLT:6.8UF,20%,35V	05397	T368B685M035AZ
A22A1C1017	283-0201-00			CAP,FXD,CER DI:27PF,10%,200V	04222	SR152C270KAA
A22A1C1019	290-0517-00			CAP,FXD,ELCTLT:6.8UF,20%,35V	05397	T368B685M035AZ
A22A1C1026	283-0051-00			CAP,FXD,CER DI:0.0033UF,5%,100V	80009	283-0051-00
A22A1C1027	290-0517-00			CAP,FXD,ELCTLT:6.8UF,20%,35V	05397	T368B685M035AZ
A22A1C1028	283-0108-00			CAP,FXD,CER DI:220PF,10%,200V	04222	SR152A221KAA
A22A1C1029	283-0051-00			CAP,FXD,CER DI:0.0033UF,5%,100V	80009	283-0051-00
A22A1C1031	283-0108-00			CAP,FXD,CER DI:220PF,10%,200V	04222	SR152A221KAA
A22A1C1033	290-0517-00			CAP,FXD,ELCTLT:6.8UF,20%,35V	05397	T368B685M035AZ
A22A1C1034	290-0517-00			CAP,FXD,ELCTLT:6.8UF,20%,35V	05397	T368B685M035AZ
A22A1C1038	283-0339-00			CAP,FXD,CER DI:0.22UF,10%,50V	04222	SR305C224KAA
A22A1C1044	283-0339-00			CAP,FXD,CER DI:0.22UF,10%,50V	04222	SR305C224KAA
A22A1C1046	283-0108-00			CAP,FXD,CER DI:220PF,10%,200V	04222	SR152A221KAA
A22A1C1047	283-0339-00			CAP,FXD,CER DI:0.22UF,10%,50V	04222	SR305C224KAA
A22A1C1073	290-0517-00			CAP,FXD,ELCTLT:6.8UF,20%,35V	05397	T368B685M035AZ
A22A1C1079	290-0517-00			CAP,FXD,ELCTLT:6.8UF,20%,35V	05397	T368B685M035AZ
A22A1C1086	283-0339-00			CAP,FXD,CER DI:0.22UF,10%,50V	04222	SR305C224KAA
A22A1C1087	283-0339-00			CAP,FXD,CER DI:0.22UF,10%,50V	04222	SR305C224KAA
A22A1C1088	283-0339-00			CAP,FXD,CER DI:0.22UF,10%,50V	04222	SR305C224KAA
A22A1C2011	290-0517-00			CAP,FXD,ELCTLT:6.8UF,20%,35V	05397	T368B685M035AZ

Replaceable Electrical Parts
494A/494AP Service Vol.2

Component No.	Tektronix Part No.	Serial/Assembly No. Effective Dscnt	Name & Description	Mfr. Code	Mfr. Part No.
A22A1C2012	283-0339-00		CAP, FXD, CER DI: 0.22UF, 10%, 50V	04222	SR305C224KAA
A22A1C2015	290-0512-00		CAP, FXD, ELCTLT: 22UF, 20%, 15V	05397	T368B226M015AS
A22A1C2016	283-0326-00		CAP, FXD, CER DI: 0.082UF, 10%, 50V	04222	SR205C823KAA
A22A1C2019	290-0517-00		CAP, FXD, ELCTLT: 6.8UF, 20%, 35V	05397	T368B685M035AZ
A22A1C2026	283-0239-00		CAP, FXD, CER DI: 0.22UF, 10%, 50V	80009	283-0239-00
A22A1C2030	283-0204-00		CAP, FXD, CER DI: 0.01UF, 20%, 50V	51406	RPE110Z5U103M50V
A22A1C2040	283-0330-00		CAP, FXD, CER DI: 100PF, 5%, 50V	80009	283-0330-00
A22A1C2041	283-0239-00		CAP, FXD, CER DI: 0.22UF, 10%, 50V	80009	283-0239-00
A22A1C2043	283-0330-00		CAP, FXD, CER DI: 100PF, 5%, 50V	80009	283-0330-00
A22A1C2046	283-0024-00		CAP, FXD, CER DI: 0.1UF, +80-20%, 50V	05397	C330C10YZ5U1CA
A22A1C2077	290-0517-00		CAP, FXD, ELCTLT: 6.8UF, 20%, 35V	05397	T368B685M035AZ
A22A1C2081	290-0517-00		CAP, FXD, ELCTLT: 6.8UF, 20%, 35V	05397	T368B685M035AZ
A22A1C2085	283-0107-00		CAP, FXD, CER DI: 51PF, 5%, 200V	04222	SR292A51QJAA
A22A1C2090	283-0175-00		CAP, FXD, CER DI: 10PF, 5%, 200V	05397	C312C100D2G5CA 8
A22A1C2091	283-0197-00		CAP, FXD, CER DI: 470PF, 5%, 50V	05397	C320C471J5G5CA
A22A1C2092	283-0339-00		CAP, FXD, CER DI: 0.22UF, 10%, 50V	04222	SR305C224KAA
A22A1CR1019	152-0141-02		DIODE, SIG: ,ULTRA FAST; 40V, 150MA, 4NS, 2PF; 1N4152, DO-35, T&R	80009	152-0141-02
A22A1CR1086	152-0141-02		DIODE, SIG: ,ULTRA FAST; 40V, 150MA, 4NS, 2PF; 1N4152, DO-35, T&R	80009	152-0141-02
A22A1CR1087	152-0141-02		DIODE, SIG: ,ULTRA FAST; 40V, 150MA, 4NS, 2PF; 1N4152, DO-35, T&R	80009	152-0141-02
A22A1CR1088	152-0141-02		DIODE, SIG: ,ULTRA FAST; 40V, 150MA, 4NS, 2PF; 1N4152, DO-35, T&R	80009	152-0141-02
A22A1CR1089	152-0719-00		DIODE, SIG: ,VVC; 30V, 100PF, 5%; 1N5456B, DO-7	04713	SMV1501
A22A1CR2012	152-0141-02		DIODE, SIG: ,ULTRA FAST; 40V, 150MA, 4NS, 2PF; 1N4152, DO-35, T&R	80009	152-0141-02
A22A1CR2014	152-0141-02		DIODE, SIG: ,ULTRA FAST; 40V, 150MA, 4NS, 2PF; 1N4152, DO-35, T&R	80009	152-0141-02
A22A1CR2015	152-0141-02		DIODE, SIG: ,ULTRA FAST; 40V, 150MA, 4NS, 2PF; 1N4152, DO-35, T&R	80009	152-0141-02
A22A1CR2019	152-0141-02		DIODE, SIG: ,ULTRA FAST; 40V, 150MA, 4NS, 2PF; 1N4152, DO-35, T&R	80009	152-0141-02
A22A1CR2048	152-0141-02		DIODE, SIG: ,ULTRA FAST; 40V, 150MA, 4NS, 2PF; 1N4152, DO-35, T&R	80009	152-0141-02
A22A1CR2084	152-0141-02		DIODE, SIG: ,ULTRA FAST; 40V, 150MA, 4NS, 2PF; 1N4152, DO-35, T&R	80009	152-0141-02
A22A1L1012	120-0407-00		XFMR, TOROID: 5 TURNS, SINGLE, 281, 25.7 UH +/- 32% @ 40 KHZ, 0.250 DIA X 0.160 H	80009	120-0407-00
A22A1L1022	108-0440-00		COIL, RF: FIXED, 8UH	80009	108-0440-00
A22A1L1097	108-0440-00		COIL, RF: FIXED, 8UH	80009	108-0440-00
A22A1L2027	120-0407-00		XFMR, TOROID: 5 TURNS, SINGLE, 281, 25.7 UH +/- 32% @ 40 KHZ, 0.250 DIA X 0.160 H	80009	120-0407-00
A22A1L2038	120-0407-00		XFMR, TOROID: 5 TURNS, SINGLE, 281, 25.7 UH +/- 32% @ 40 KHZ, 0.250 DIA X 0.160 H	80009	120-0407-00
A22A1Q1012	151-0103-00		TRANSISTOR, SIG: BIPOLAR, NPN; 40V, 800MA, 300MHZ, AMPLIFIER; 2N2219A, TO-39	80009	151-0103-00
A22A1Q1023	151-0103-00		TRANSISTOR, SIG: BIPOLAR, NPN; 40V, 800MA, 300MHZ, AMPLIFIER; 2N2219A, TO-39	80009	151-0103-00
A22A1Q1041	151-0441-00		TRANSISTOR, SIG: BIPOLAR, NPN; 15V, 40MA, 1.0GHZ, AMPLIFIER; 2N2857/2N3839, TO-72	80009	151-0441-00
A22A1Q1042	151-0441-00		TRANSISTOR, SIG: BIPOLAR, NPN; 15V, 40MA, 1.0GHZ, AMPLIFIER; 2N2857/2N3839, TO-72	80009	151-0441-00
A22A1Q1043	151-0441-00		TRANSISTOR, SIG: BIPOLAR, NPN; 15V, 40MA, 1.0GHZ, AMPLIFIER; 2N2857/2N3839, TO-72	80009	151-0441-00
A22A1Q1047	151-0301-00		TRANSISTOR, SIG: BIPOLAR, PNP; 60V, 600MA, 200MHZ, AMPLIFIER; 2N2907A, TO-18	80009	151-0301-00

Replaceable Electrical Parts
494A/494AP Service Vol.2

Component No.	Tektronix	Serial/Assembly No.		Name & Description	Mfr.	Mfr. Part No.
	Part No.	Effective	Discont		Code	
A22A1Q2024	151-0301-00			TRANSISTOR, SIG: BIPOLAR, PNP; 60V, 600MA, 200MHZ , AMPLIFIER; 2N2907A, TO-18	80009	151-0301-00
A22A1Q2076	151-0301-00			TRANSISTOR, SIG: BIPOLAR, PNP; 60V, 600MA, 200MHZ , AMPLIFIER; 2N2907A, TO-18	80009	151-0301-00
A22A1Q2084	151-1022-00			TRANSISTOR, SIG: JFET, N-CH; 4V, 75MA, 80 OHM, SEL ECTED FOR VGS(OFF); 2N4392 FAMILY, TO-18	80009	151-1022-00
A22A1Q2087	151-0441-00			TRANSISTOR, SIG: BIPOLAR, NPN; 15V, 40MA, 1.0GHZ, AMPLIFIER; 2N2857/2N3839, TO-72	80009	151-0441-00
A22A1Q2096	151-0441-00			TRANSISTOR, SIG: BIPOLAR, NPN; 15V, 40MA, 1.0GHZ, AMPLIFIER; 2N2857/2N3839, TO-72	80009	151-0441-00
A22A1R1010	315-0750-00			RES, FXD, FILM: 75 OHM, 5%, 0.25W	80009	315-0750-00
A22A1R1011	315-0471-00			RES, FXD, FILM: 470 OHM, 5%, 0.25W	80009	315-0471-00
A22A1R1013	315-0101-00			RES, FXD, FILM: 100 OHM, 5%, 0.25W	80009	315-0101-00
A22A1R1014	315-0100-00			RES, FXD, FILM: 10 OHM, 5%, 0.25W	19701	5043CX10RR00J
A22A1R1015	321-0297-00			RES, FXD, FILM: 12.1K OHM, 1%, 0.125W, TC=TO	07716	CEAD12101F
A22A1R1016	321-0262-00			RES, FXD, FILM: 5.23K OHM, 1%, 0.125W, TC=TO	19701	5033ED5K230F
A22A1R1018	315-0101-00			RES, FXD, FILM: 100 OHM, 5%, 0.25W	80009	315-0101-00
A22A1R1019	315-0470-00			RES, FXD, FILM: 47 OHM, 5%, 0.25W	80009	315-0470-00
A22A1R1023	315-0200-00			RES, FXD, FILM: 20 OHM, 5%, 0.25W	80009	315-0200-00
A22A1R1024	315-0390-00			RES, FXD, FILM: 39 OHM, 5%, 0.25W	80009	315-0390-00
A22A1R1025	315-0101-00			RES, FXD, FILM: 100 OHM, 5%, 0.25W	80009	315-0101-00
A22A1R1026	315-0302-00			RES, FXD, FILM: 3K OHM, 5%, 0.25W	80009	315-0302-00
A22A1R1027	315-0302-00			RES, FXD, FILM: 3K OHM, 5%, 0.25W	80009	315-0302-00
A22A1R1028	315-0102-00			RES, FXD, FILM: 1K OHM, 5%, 0.25W	80009	315-0102-00
A22A1R1029	315-0101-00			RES, FXD, FILM: 100 OHM, 5%, 0.25W	80009	315-0101-00
A22A1R1031	315-0102-00			RES, FXD, FILM: 1K OHM, 5%, 0.25W	80009	315-0102-00
A22A1R1033	321-0821-00			RES, FXD, FILM: 2.12K OHM, 1%, 0.125W, TC=TO	80009	321-0821-00
A22A1R1034	321-0217-00			RES, FXD, FILM: 1.78K OHM, 1%, 0.125W, TC=TO	80009	321-0217-00
A22A1R1035	315-0101-00			RES, FXD, FILM: 100 OHM, 5%, 0.25W	80009	315-0101-00
A22A1R1037	317-0200-00			RES, FXD, CMPSN: 20 OHM, 5%, 0.125W	80009	317-0200-00
A22A1R1038	317-0161-00			RES, FXD, CMPSN: 160 OHM, 5%, 0.125W	80009	317-0161-00
A22A1R1039	317-0161-00			RES, FXD, CMPSN: 160 OHM, 5%, 0.125W	80009	317-0161-00
A22A1R1040	317-0511-00			RES, FXD, CMPSN: 510 OHM, 5%, 0.125W	80009	317-0511-00
A22A1R1042	317-0391-00			RES, FXD, CMPSN: 390 OHM, 5%, 0.125W	80009	317-0391-00
A22A1R1043	317-0111-00			RES, FXD, CMPSN: 110 OHM, 5%, 0.125W	80009	317-0111-00
A22A1R1046	317-0820-00			RES, FXD, CMPSN: 82 OHM, 5%, 0.125W	80009	317-0820-00
A22A1R1048	317-0680-00			RES, FXD, CMPSN: 68 OHM, 5%, 0.125W	80009	317-0680-00
A22A1R1051	321-0294-00			RES, FXD, FILM: 11.3K OHM, 1%, 0.125W, TC=TO	80009	321-0294-00
A22A1R1052	321-0319-00			RES, FXD, FILM: 20.5K OHM, 1%, 0.125W, TC=TO	80009	321-0319-00
A22A1R1053	321-0340-00			RES, FXD, FILM: 34.0K OHM, 1%, 0.125W, TC=TO	80009	321-0340-00
A22A1R1054	321-0361-00			RES, FXD, FILM: 56.2K OHM, 1%, 0.125W, TC=TO	07716	CEAD56201F
A22A1R1055	321-0387-00			RES, FXD, FILM: 105K OHM, 1%, 0.125W, TC=TO	07716	CEAD10502F
A22A1R1056	321-0437-00			RES, FXD, FILM: 348K OHM, 1%, 0.125W, TC=TO	80009	321-0437-00
A22A1R1060	321-0437-00			RES, FXD, FILM: 348K OHM, 1%, 0.125W, TC=TO	80009	321-0437-00
A22A1R1061	321-0391-00			RES, FXD, FILM: 115K OHM, 1%, 0.125W, TC=TO	07716	CEAD11502F
A22A1R1062	321-0368-00			RES, FXD, FILM: 66.5K OHM, 1%, 0.125W, TC=TO	07716	CEAD66501F
A22A1R1063	321-0353-00			RES, FXD, FILM: 46.4K OHM, 1%, 0.125W, TC=TO	07716	CEAD46401F
A22A1R1064	321-0341-00			RES, FXD, FILM: 34.8K OHM, 1%, 0.125W, TC=TO	80009	321-0341-00
A22A1R1065	321-0331-00			RES, FXD, FILM: 27.4K OHM, 1%, 0.125W, TC=TO	80009	321-0331-00
A22A1R1070	321-0268-00			RES, FXD, FILM: 6.04K OHM, 1%, 0.125W, TC=TO	57688	CRB14FXE6.04KOHM
A22A1R1072	321-0222-00			RES, FXD, FILM: 2.00K OHM, 1%, 0.125W, TC=TO	80009	321-0222-00
A22A1R1073	315-0470-00			RES, FXD, FILM: 47 OHM, 5%, 0.25W	80009	315-0470-00
A22A1R1074	321-0201-00			RES, FXD, FILM: 1.21K OHM, 1%, 0.125W, TC=TO	80009	321-0201-00
A22A1R1076	321-0302-00			RES, FXD, FILM: 13.7K OHM, 1%, 0.125W, TC=TO	07716	CEAD 13701F
A22A1R1079	321-0289-00			RES, FXD, FILM: 10.0K OHM, 1%, 0.125W, TC=TO	57688	FXE10K0
A22A1R1080	315-0471-00			RES, FXD, FILM: 470 OHM, 5%, 0.25W	80009	315-0471-00
A22A1R1081	315-0470-00			RES, FXD, FILM: 47 OHM, 5%, 0.25W	80009	315-0470-00
A22A1R1082	321-0335-00			RES, FXD, FILM: 30.1K OHM, 1%, 0.125W, TC=TO	80009	321-0335-00

Replaceable Electrical Parts
494A/494AP Service Vol.2

Component No.	Tektronix		Serial/Assembly No.	Name & Description	Mfr. Code	Mfr. Part No.
	Part No.	Effective Discnt				
A22A1R1083	315-0432-00			RES,FXD,FILM:4.3K OHM,5%,0.25W	80009	315-0432-00
A22A1R1086	315-0471-00			RES,FXD,FILM:470 OHM,5%,0.25W	80009	315-0471-00
A22A1R1097	315-0390-00			RES,FXD,FILM:39 OHM,5%,0.25W	80009	315-0390-00
A22A1R2010	321-1296-07			RES,FXD,FILM:12.0K OHM,0.1%,0.125W,TC=T9	80009	321-1296-07
A22A1R2011	321-1296-07			RES,FXD,FILM:12.0K OHM,0.1%,0.125W,TC=T9	80009	321-1296-07
A22A1R2012	315-0470-00			RES,FXD,FILM:47 OHM,5%,0.25W	80009	315-0470-00
A22A1R2013	315-0103-00			RES,FXD,FILM:10K OHM,5%,0.25W	80009	315-0103-00
A22A1R2014	315-0332-00			RES,FXD,FILM:3.3K OHM,5%,0.25W	80009	315-0332-00
A22A1R2015	315-0102-00			RES,FXD,FILM:1K OHM,5%,0.25W	80009	315-0102-00
A22A1R2016	321-0264-07			RES,FXD,FILM:5.49K OHM,0.1%,0.125W,TC=T9	07716	CEAE54900B
A22A1R2017	321-1617-06			RES,FXD,FILM:5.85K OHM,0.25%,0.125W,TC=T9	07716	CEAE58500C
A22A1R2018	315-0302-00			RES,FXD,FILM:3K OHM,5%,0.25W	80009	315-0302-00
A22A1R2019	315-0751-00			RES,FXD,FILM:750 OHM,5%,0.25W	80009	315-0751-00
A22A1R2020	315-0152-00			RES,FXD,FILM:1.5K OHM,5%,0.25W	80009	315-0152-00
A22A1R2025	315-0240-00			RES,FXD,FILM:24 OHM,5%,0.25W	80009	315-0240-00
A22A1R2026	315-0270-00			RES,FXD,FILM:27 OHM,5%,0.25W	80009	315-0270-00
A22A1R2027	315-0102-00			RES,FXD,FILM:1K OHM,5%,0.25W	80009	315-0102-00
A22A1R2028	315-0152-00			RES,FXD,FILM:1.5K OHM,5%,0.25W	80009	315-0152-00
A22A1R2030	315-0102-00			RES,FXD,FILM:1K OHM,5%,0.25W	80009	315-0102-00
A22A1R2031	315-0152-00			RES,FXD,FILM:1.5K OHM,5%,0.25W	80009	315-0152-00
A22A1R2032	315-0131-00			RES,FXD,FILM:130 OHM,5%,0.25W	80009	315-0131-00
A22A1R2033	315-0102-00			RES,FXD,FILM:1K OHM,5%,0.25W	80009	315-0102-00
A22A1R2035	315-0152-00			RES,FXD,FILM:1.5K OHM,5%,0.25W	80009	315-0152-00
A22A1R2037	315-0152-00			RES,FXD,FILM:1.5K OHM,5%,0.25W	80009	315-0152-00
A22A1R2039	315-0270-00			RES,FXD,FILM:27 OHM,5%,0.25W	80009	315-0270-00
A22A1R2041	315-0161-00			RES,FXD,FILM:160 OHM,5%,0.25W	19701	5043CX160ROJ
A22A1R2042	315-0391-00			RES,FXD,FILM:390 OHM,5%,0.25W	80009	315-0391-00
A22A1R2044	315-0161-00			RES,FXD,FILM:160 OHM,5%,0.25W	19701	5043CX160ROJ
A22A1R2045	315-0102-00			RES,FXD,FILM:1K OHM,5%,0.25W	80009	315-0102-00
A22A1R2046	321-0205-00			RES,FXD,FILM:1.33K OHM,1%,0.125W,TC=T0	80009	321-0205-00
A22A1R2049	321-0268-00			RES,FXD,FILM:6.04K OHM,1%,0.125W,TC=T0	57688	CRB14FXE6.04KOHM
A22A1R2051	321-0329-00			RES,FXD,FILM:26.1K OHM,1%,0.125W,TC=T0	80009	321-0329-00
A22A1R2052	321-0326-00			RES,FXD,FILM:24.3K OHM,1%,0.125W,TC=T0	80009	321-0326-00
A22A1R2053	321-0323-00			RES,FXD,FILM:22.6K OHM,1%,0.125W,TC=T0	80009	321-0323-00
A22A1R2054	321-0319-00			RES,FXD,FILM:20.5K OHM,1%,0.125W,TC=T0	80009	321-0319-00
A22A1R2055	321-0316-00			RES,FXD,FILM:19.1K OHM,1%,0.125W,TC=T0	07716	CEAD19101F
A22A1R2056	321-0313-00			RES,FXD,FILM:17.8K OHM,1%,0.125W,TC=T0	07716	CEAD17801F
A22A1R2060	321-0309-00			RES,FXD,FILM:16.2K OHM,1%,0.125W,TC=T0	80009	321-0309-00
A22A1R2061	321-0306-00			RES,FXD,FILM:15.0K OHM,1%,0.125W,TC=T0	80009	321-0306-00
A22A1R2062	321-0303-00			RES,FXD,FILM:14.0K OHM,1%,0.125W,TC=T0	07716	CEAD 14001F
A22A1R2063	321-0299-00			RES,FXD,FILM:12.7K OHM,1%,0.125W,TC=T0	80009	321-0299-00
A22A1R2064	321-0296-00			RES,FXD,FILM:11.8K OHM,1%,0.125W,TC=T0	07716	CEAD11801F
A22A1R2065	321-0293-00			RES,FXD,FILM:11.0K OHM,1%,0.125W,TC=T0	07716	CEAD11001F
A22A1R2066	321-0289-00			RES,FXD,FILM:10.0K OHM,1%,0.125W,TC=T0	57668	FXE10KO
A22A1R2067	321-0289-00			RES,FXD,FILM:10.0K OHM,1%,0.125W,TC=T0	57668	FXE10KO
A22A1R2068	321-0285-09			RES,FXD,FILM:9.09K OHM,1%,0.125W,TC=T9	2M627	CRA18FZ9.09KOHM
A22A1R2070	321-0268-00			RES,FXD,FILM:6.04K OHM,1%,0.125W,TC=T0	57688	CRB14FXE6.04KOHM
A22A1R2071	321-0268-00			RES,FXD,FILM:6.04K OHM,1%,0.125W,TC=T0	57688	CRB14FXE6.04KOHM
A22A1R2072	321-0249-00			RES,FXD,FILM:3.83K OHM,1%,0.125W,TC=T0	80009	321-0249-00
A22A1R2073	315-0101-00			RES,FXD,FILM:100 OHM,5%,0.25W	80009	315-0101-00
A22A1R2074	315-0562-00			RES,FXD,FILM:5.6K OHM,5%,0.25W	80009	315-0562-00
A22A1R2075	315-0103-00			RES,FXD,FILM:10K OHM,5%,0.25W	80009	315-0103-00
A22A1R2077	321-0286-00			RES,FXD,FILM:9.31K OHM,1%,0.125W,TC=T0	80009	321-0286-00
A22A1R2080	315-0101-00			RES,FXD,FILM:100 OHM,5%,0.25W	80009	315-0101-00
A22A1R2082	321-0229-00			RES,FXD,FILM:2.37K OHM,1%,0.125W,TC=T0	80009	321-0229-00
A22A1R2083	321-0321-00			RES,FXD,FILM:21.5K OHM,1%,0.125W,TC=T0	07716	CEAD21501F
A22A1R2084	315-0202-00			RES,FXD,FILM:2K OHM,5%,0.25W	80009	315-0202-00
A22A1R2085	315-0105-00			RES,FXD,FILM:1M OHM,5%,0.25W	80009	315-0105-00

Replaceable Electrical Parts
494A/494AP Service Vol.2

Component No.	Tektronix Part No.	Serial/Assembly No.		Name & Description	Mfr. Code	Mfr. Part No.
		Effective	Discont			
A22A1R2086	315-0473-00			RES, FXD, FILM: 47K OHM, 5%, 0.25W	80009	315-0473-00
A22A1R2087	315-0102-00			RES, FXD, FILM: 1K OHM, 5%, 0.25W	80009	315-0102-00
A22A1R2088	315-0102-00			RES, FXD, FILM: 1K OHM, 5%, 0.25W	80009	315-0102-00
A22A1R2089	315-0102-00			RES, FXD, FILM: 1K OHM, 5%, 0.25W	80009	315-0102-00
A22A1R2090	321-0272-00			RES, FXD, FILM: 6.65K OHM, 1%, 0.125W, TC=T0	80009	321-0272-00
A22A1R2092	315-0101-00			RES, FXD, FILM: 100 OHM, 5%, 0.25W	80009	315-0101-00
A22A1R2093	321-0272-00			RES, FXD, FILM: 6.65K OHM, 1%, 0.125W, TC=T0	80009	321-0272-00
A22A1R2097	321-0114-00			RES, FXD, FILM: 150 OHM, 1%, 0.125 W, TC=T0	80009	321-0114-00
A22A1T1091	120-1386-00			TRANSFORMER, RF: TOROID	80009	120-1386-00
A22A1T2092	120-1392-00			TRANSFORMER, RF: TOROID	80009	120-1392-00
A22A1U1017	156-0105-04			IC, LINEAR: BIPOLAR, OP-AMP; DUPLICATE OF 156-0105-00, DO NOT USE; LM301AP, DIP08.3	80009	156-0105-04
A22A1U1031	156-1338-00			IC, LINEAR: BIPOLAR, OP-AMP; HIGH OUTPUT DRIVE; NE5534N, DIP08.3	80009	156-1338-00
A22A1U1059	156-1545-00			MICROCKT, LINEAR: DIODE ARRAY 7 ISOL DIODES	07263	FSA2720M
A22A1U1073	156-1272-03			IC, LINEAR: BIPOLAR, OP-AMP; DUAL, HIGH OUTPUT DRIVE, MAX NOISE SPECS; NE5532AN, DIP08.3	80009	156-1272-03
A22A1U2016	156-1272-03			IC, LINEAR: BIPOLAR, OP-AMP; DUAL, HIGH OUTPUT DRIVE, MAX NOISE SPECS; NE5532AN, DIP08.3	80009	156-1272-03
A22A1U2031	156-0230-00			IC, DIGITAL: ECL, FLIP FLOP; DUAL D-TYPE MASTER SLAVE; 10131, DIP16.3, TUBE	80009	156-0230-00
A22A1U2041	156-0860-00			IC, DIGITAL: ECL, RECEIVER; TRIPLE LINE; 10116, DIP16.3, TUBE	80009	156-0860-00
A22A1U2059	156-1545-00			MICROCKT, LINEAR: DIODE ARRAY 7 ISOL DIODES	07263	FSA2720M
A22A1U2072	156-1272-03			IC, LINEAR: BIPOLAR, OP-AMP; DUAL, HIGH OUTPUT DRIVE, MAX NOISE SPECS; NE5532AN, DIP08.3	80009	156-1272-03
A22A1VR2021	152-0486-00			DIODE, ZENER: , 6.2V, 2%, 0.4W; 1N825 FMLY, DO-35 OR 7, TR	80009	152-0486-00
A22A1W2069	131-0566-00			BUS, CONDUCTOR: DUMMY RES, 0.094 OD X 0.225 L	80009	131-0566-00
A22A1W2081	131-0566-00			BUS, CONDUCTOR: DUMMY RES, 0.094 OD X 0.225 L	80009	131-0566-00
A22A2	-----			(PART OF A22)		
A22A2C2200	281-0825-00			CAP, FXD, CER DI: 0.005UF, +100-0%, 100V	33095	51-726-008
A22A2C2201	281-0825-00			CAP, FXD, CER DI: 0.005UF, +100-0%, 100V	33095	51-726-008
A22A2C2202	281-0825-00			CAP, FXD, CER DI: 0.005UF, +100-0%, 100V	33095	51-726-008
A22A2C2203	281-0875-00			CAP, FXD, CER DI: 100PF, 20%, 200V	72982	2425001X5U101M
A22A2C2204	281-0875-00			CAP, FXD, CER DI: 100PF, 20%, 200V	72982	2425001X5U101M
A22A2P220	131-2017-00			CONN, RF JACK: :	80009	131-2017-00
A22A2P221	131-1170-00			CONN, RF JACK:	80009	131-1170-00
A22A2P222	131-2017-00			CONN, RF JACK: :	80009	131-2017-00
A22A2AAC1014	283-0181-00			CAP, FXD, CER DI: 1.8PF, +/-0.1%, 100V	80009	283-0181-00
A22A2A1	670-7395-01			CIRCUIT BD ASSY: 2182MHZ MICRO STRIP OSC	80009	670-7395-01
A22A2A1C1011	283-0181-00			CAP, FXD, CER DI: 1.8PF, +/-0.1%, 100V	80009	283-0181-00
A22A2A1C1013	283-0220-00			CAP, FXD, CER DI: 0.01UF, 20%, 50V	04222	SR205C103MAA
A22A2A1C1033	283-0181-00			CAP, FXD, CER DI: 1.8PF, +/-0.1%, 100V	80009	283-0181-00
A22A2A1C2011	283-0220-00			CAP, FXD, CER DI: 0.01UF, 20%, 50V	04222	SR205C103MAA
A22A2A1C2012	283-0181-00			CAP, FXD, CER DI: 1.8PF, +/-0.1%, 100V	80009	283-0181-00
A22A2A1C2013	283-0181-00			CAP, FXD, CER DI: 1.8PF, +/-0.1%, 100V	80009	283-0181-00
A22A2A1C2023	283-0181-00			CAP, FXD, CER DI: 1.8PF, +/-0.1%, 100V	80009	283-0181-00
A22A2A1C2024	290-0517-00			CAP, FXD, ELCTLT: 6.8UF, 20%, 35V	05397	T368B685M035AZ
A22A2A1C2025	283-0181-00			CAP, FXD, CER DI: 1.8PF, +/-0.1%, 100V	80009	283-0181-00
A22A2A1C2031	283-0181-00			CAP, FXD, CER DI: 1.8PF, +/-0.1%, 100V	80009	283-0181-00
A22A2A1C2032	283-0220-00			CAP, FXD, CER DI: 0.01UF, 20%, 50V	04222	SR205C103MAA
A22A2A1C2033	283-0220-00			CAP, FXD, CER DI: 0.01UF, 20%, 50V	04222	SR205C103MAA
A22A2A1CR1028	152-0722-00			SEMICONV DVC, DI: VVC, SI, 45 V, 1.5 PF AT 4 V	17540	DVH-6934-98
A22A2A1CR2013	152-0141-02			DIODE, SIG: , ULTRA FAST; 40V, 150MA, 4NS, 2PF; 1N4152, DO-35, T&R	80009	152-0141-02
A22A2A1CR2021	152-0141-02			DIODE, SIG: , ULTRA FAST; 40V, 150MA, 4NS, 2PF; 1N4152, DO-35, T&R	80009	152-0141-02

Replaceable Electrical Parts
494A/494AP Service Vol.2

Component No.	Tektronix	Serial/Assembly No.		Name & Description	Mfr.	Mfr. Part No.
	Part No.	Effective	Discont		Code	
A22A2A1CR2031	152-0141-02			DIODE, SIG: ULTRA FAST; 40V, 150MA, 4NS, 2PF; 1N4152, DO-35, T&R	80009	152-0141-02
A22A2A1L1011	108-0682-00			COIL, RF: FIXED, 61NH	80009	108-0682-00
A22A2A1L1014	108-0682-00			COIL, RF: FIXED, 61NH	80009	108-0682-00
A22A2A1L2011	108-0682-00			COIL, RF: FIXED, 61NH	80009	108-0682-00
A22A2A1L2013	108-0682-00			COIL, RF: FIXED, 61NH	80009	108-0682-00
A22A2A1L2023	108-0682-00			COIL, RF: FIXED, 61NH	80009	108-0682-00
A22A2A1L2025	108-0682-00			COIL, RF: FIXED, 61NH	80009	108-0682-00
A22A2A1L2031	108-0682-00			COIL, RF: FIXED, 61NH	80009	108-0682-00
A22A2A1L2032	108-0682-00			COIL, RF: FIXED, 61NH	80009	108-0682-00
A22A2A1L2033	108-0682-00			COIL, RF: FIXED, 61NH	80009	108-0682-00
A22A2A1Q1011	151-0689-00			TRANSISTOR, SIG: BIPOLAR, NPN; 11V, 30MA, 4.0GHZ, AMPLIFIER; NE57835, 4 PIN CERAMIC X PKG	80009	151-0689-00
A22A2A1Q1021	151-0630-00			TRANSISTOR, SIG: BIPOLAR, NPN; 12V, 70MA, 4.5GHZ, AMPLIFIER; NE02135, 4 PIN CERAMIC X PKG	S0545	NE02135
A22A2A1Q1031	151-0689-00			TRANSISTOR, SIG: BIPOLAR, NPN; 11V, 30MA, 4.0GHZ, AMPLIFIER; NE57835, 4 PIN CERAMIC X PKG	80009	151-0689-00
A22A2A1Q2021	151-0301-00			TRANSISTOR, SIG: BIPOLAR, PNP; 60V, 600MA, 200MHZ, AMPLIFIER; 2N2907A, TO-18	80009	151-0301-00
A22A2A1R1011	317-0101-00			RES, FXD, CMPSN: 100 OHM, 5%, 0.125W	80009	317-0101-00
A22A2A1R1012	321-0134-00			RES, FXD, FILM: 243 OHM, 1%, 0.125W, TC=TO	80009	321-0134-00
A22A2A1R1013	321-0216-00			RES, FXD, FILM: 1.74K OHM, 1%, 0.125W, TC=TO	07716	CEAD17400F
A22A2A1R1015	317-0104-00			RES, FXD, CMPSN: 100K OHM, 5%, 0.125W	80009	317-0104-00
A22A2A1R1021	317-0101-00			RES, FXD, CMPSN: 100 OHM, 5%, 0.125W	80009	317-0101-00
A22A2A1R1022	317-0101-00			RES, FXD, CMPSN: 100 OHM, 5%, 0.125W	80009	317-0101-00
A22A2A1R1023	317-0240-00			RES, FXD, CMPSN: 24 OHM, 5%, 0.125W	80009	317-0240-00
A22A2A1R1026	317-0240-00			RES, FXD, CMPSN: 24 OHM, 5%, 0.125W	80009	317-0240-00
A22A2A1R1027	317-0101-00			RES, FXD, CMPSN: 100 OHM, 5%, 0.125W	80009	317-0101-00
A22A2A1R1028	317-0101-00			RES, FXD, CMPSN: 100 OHM, 5%, 0.125W	80009	317-0101-00
A22A2A1R1029	317-0240-00			RES, FXD, CMPSN: 24 OHM, 5%, 0.125W	80009	317-0240-00
A22A2A1R1032	317-0101-00			RES, FXD, CMPSN: 100 OHM, 5%, 0.125W	80009	317-0101-00
A22A2A1R1033	317-0101-00			RES, FXD, CMPSN: 100 OHM, 5%, 0.125W	80009	317-0101-00
A22A2A1R2013	321-0250-00			RES, FXD, FILM: 3.92K OHM, 1%, 0.125W, TC=TO	07716	CEAD39200F
A22A2A1R2014	317-0243-00			RES, FXD, CMPSN: 24K OHM, 5%, 0.125W	80009	317-0243-00
A22A2A1R2015	317-0472-00			RES, FXD, CMPSN: 4.7K OHM, 5%, 0.125W	80009	317-0472-00
A22A2A1R2016	317-0622-00			RES, FXD, CMPSN: 6.2K OHM, 5%, 0.125W	80009	317-0622-00
A22A2A1R2017	317-0390-00			RES, FXD, CMPSN: 39 OHM, 5%, 0.125W	80009	317-0390-00
A22A2A1R2021	317-0103-00			RES, FXD, CMPSN: 10K OHM, 5%, 0.125W	80009	317-0103-00
A22A2A1R2022	317-0102-00			RES, FXD, CMPSN: 1K OHM, 5%, 0.125W	80009	317-0102-00
A22A2A1R2023	317-0390-00			RES, FXD, CMPSN: 39 OHM, 5%, 0.125W	80009	317-0390-00
A22A2A1R2024	317-0151-00			RES, FXD, CMPSN: 150 OHM, 5%, 0.125W	80009	317-0151-00
A22A2A1R2025	317-0101-00			RES, FXD, CMPSN: 100 OHM, 5%, 0.125W	80009	317-0101-00
A22A2A1R2030	317-0101-00			RES, FXD, CMPSN: 100 OHM, 5%, 0.125W	80009	317-0101-00
A22A2A1R2031	321-0265-00			RES, FXD, FILM: 5.62K OHM, 1%, 0.125W, TC=TO	80009	321-0265-00
A22A2A1R2032	321-0932-00			RES, FXD, FILM: 2.5K OHM, 1%, 0.125W, TC=TO	01121	
A22A2A1R2033	321-0149-00			RES, FXD, FILM: 348 OHM, 1%, 0.125W, TC=TO	07716	CEAD348R0F
A22A2A2	670-7076-01			CIRCUIT BD ASSY: 2200MHZ REF	80009	670-7076-01
A22A2A2C1025	283-0157-00			CAP, FXD, CER DI: 7PF, 5%, 50V	04222	SR155A7R0DAA
A22A2A2C1029	283-0070-00			CAP, FXD, CER DI: 30PF, 10%, 50V	51642	200-050-NPO-300K
A22A2A2C1036	283-0154-00			CAP, FXD, CER DI: 22PF, 5%, 50V	05397	C315C220J5G5CA
A22A2A2C1038	283-0156-00			CAP, FXD, CER DI: 1000PF, +80-20%, 200V	04222	SR152E102ZAA
A22A2A2C2015	283-0185-00			CAP, FXD, CER DI: 2.5PF, 0.5%, 50V	51642	100-050-NPO-259B
A22A2A2C2021	283-0220-00			CAP, FXD, CER DI: 0.01UF, 20%, 50V	04222	SR205C103MAA
A22A2A2C2023	283-0326-00			CAP, FXD, CER DI: 0.082UF, 10%, 50V	04222	SR205C823KAA
A22A2A2C2026	283-0108-00			CAP, FXD, CER DI: 220PF, 10%, 200V	04222	SR152A221KAA
A22A2A2C3015	283-0158-00			CAP, FXD, CER DI: 1PF, +/-0.1PF, 50V	80009	283-0158-00
A22A2A2C3024	290-0517-00			CAP, FXD, ELCTLT: 6.8UF, 20%, 35V	05397	T368B685M035AZ
A22A2A2CR2014	152-0153-00			SEMICON DVC, DI: SW, SI, 10V, 50MA, .DO-7	07263	FD7003

Replaceable Electrical Parts
494A/494AP Service Vol.2

Component No.	Tektronix Part No.	Serial/Assembly No. Effective Dscort	Name & Description	Mfr. Code	Mfr. Part No.
A22A2A2E2014	276-0543-00		SHLD BEAD,ELEK:FERRITE	80009	276-0543-00
A22A2A2E2015	276-0543-00		SHLD BEAD,ELEK:FERRITE	80009	276-0543-00
A22A2A2L1025	108-0436-00		COIL,RF:FIXED,240UH ON FORM	80009	108-0436-00
A22A2A2L1034	108-0733-00		COIL,RF:FIXED,117NH	80009	108-0733-00
A22A2A2Q1024	151-0441-00		TRANSISTOR,SIG:BIPOLAR,NPN;15V,40MA,1.0GHZ,AMPLIFIER;2N2857/2N3839,TO-72	80009	151-0441-00
A22A2A2Q2024	151-0441-00		TRANSISTOR,SIG:BIPOLAR,NPN;15V,40MA,1.0GHZ,AMPLIFIER;2N2857/2N3839,TO-72	80009	151-0441-00
A22A2A2R2018	317-0330-00		RES,FXD,CMPSN:33 OHM,5%,0.125W	80009	317-0330-00
A22A2A2R2019	317-0431-00		RES,FXD,CMPSN:430 OHM,5%,0.125W	80009	317-0431-00
A22A2A2R2021	315-0122-00		RES,FXD,FILM:1.2K OHM,5%,0.25W	80009	315-0122-00
A22A2A2R2023	315-0821-00		RES,FXD,FILM:820 OHM,5%,0.25W	80009	315-0821-00
A22A2A2R2032	315-0331-00		RES,FXD,FILM:330 OHM,5%,0.25W	80009	315-0331-00
A22A2A2R2033	315-0331-00		RES,FXD,FILM:330 OHM,5%,0.25W	80009	315-0331-00
A22A2A2R3014	317-0301-00		RES,FXD,CMPSN:300 OHM,5%,0.125W	80009	317-0301-00
A22A2A2R3015	317-0360-00		RES,FXD,CMPSN:36 OHM,5%,0.125W	80009	317-0360-00
A22A2A2R3016	317-0360-00		RES,FXD,CMPSN:36 OHM,5%,0.125W	80009	317-0360-00
A22A2A2R3021	317-0301-00		RES,FXD,CMPSN:300 OHM,5%,0.125W	80009	317-0301-00
A22A2A2R3025	315-0470-00		RES,FXD,FILM:47 OHM,5%,0.25W	80009	315-0470-00
A22A2A2T2015	120-1393-00		TRANSFORMER,RF:BALUN	80009	120-1393-00
A22A2A3	670-7079-00		CIRCUIT BD ASSY:2200MHZ REFERENCE MIXER	80009	670-7079-00
A22A2A3C1013	283-0107-00		CAP,FXD,CER DI:51PF,5%,200V	04222	SR292A510JAA
A22A2A3C1014	283-0108-00		CAP,FXD,CER DI:220PF,10%,200V	04222	SR152A221KAA
A22A2A3C1015	283-0108-00		CAP,FXD,CER DI:220PF,10%,200V	04222	SR152A221KAA
A22A2A3C1016	283-0139-00		CAP,FXD,CERAMIC:MLC;150PF,10%,50V,COG,0.138 X 0.120;RADIAL,BULK	80009	283-0139-00
A22A2A3CR1011	152-0322-00		DIODE,SIG:SCHTKY.;15V,410MVF AT 1MA,1.2PF;5082-2811,T&R	80009	152-0322-00
A22A2A3CR1012	152-0322-00		DIODE,SIG:SCHTKY.;15V,410MVF AT 1MA,1.2PF;5082-2811,T&R	80009	152-0322-00
A22A2A3L1013	108-0182-00		COIL,RF:FIXED,293NH	80009	108-0182-00
A22A2A3L1014	108-0182-00		COIL,RF:FIXED,293NH	80009	108-0182-00
A22A2A3L1015	108-0182-00		COIL,RF:FIXED,293NH	80009	108-0182-00
A23	119-1131-05		SEC CONN ASSY:829MHZ	80009	119-1131-05
A23C230	281-0825-00		CAP,FXD,CER DI:0.005UF,+100-0%,100V	33095	51-726-008
A23C231	281-0697-00		CAP,FXD,CER DI:5000PF,+100-0%,100V	80009	281-0697-00
A23C232	281-0825-00		CAP,FXD,CER DI:0.005UF,+100-0%,100V	33095	51-726-008
A23C233	281-0697-00		CAP,FXD,CER DI:5000PF,+100-0%,100V	80009	281-0697-00
A23C234	281-0825-00		CAP,FXD,CER DI:0.005UF,+100-0%,100V	33095	51-726-008
A23C235	281-0697-00		CAP,FXD,CER DI:5000PF,+100-0%,100V	80009	281-0697-00
A23C236	281-0825-00		CAP,FXD,CER DI:0.005UF,+100-0%,100V	33095	51-726-008
A23C237	281-0697-00		CAP,FXD,CER DI:5000PF,+100-0%,100V	80009	281-0697-00
A23C239	281-0697-00		CAP,FXD,CER DI:5000PF,+100-0%,100V	80009	281-0697-00
A23P231	131-2017-00		CONN,RF JACK:.	80009	131-2017-00
A23P232	131-1170-00		CONN,RF JACK:.	80009	131-1170-00
A23P233	131-1170-00		CONN,RF JACK:.	80009	131-1170-00
A23P235	131-1170-00		CONN,RF JACK:.	80009	131-1170-00
A23P236	131-2017-00		CONN,RF JACK:.	80009	131-2017-00
A23P237	131-2017-00		CONN,RF JACK:.	80009	131-2017-00
A23U1013	156-0285-00		IC,LINER:BIPOLAR,VOLTAGE REGULATOR;POSITIV E,12V,1.0A,4%;MC7812CT,TO-220	80009	156-0285-00
A23U2026	156-0872-00		IC,LINER:BIPOLAR,VOLTAGE REGULATOR;NEGATIV E,-12V,1.0A,4%;MC7912CT,TO-220	04713	MC7912CT
A23U3024	156-0277-00		IC,LINER:BIPOLAR,VOLTAGE REGULATOR;POSITIV E,5.0V,1.0A,4%;MC7805CT,TO-220	80009	156-0277-00
A23A1	670-5936-00		CIRCUIT BD ASSY:719MHZ SECOND LO	80009	670-5936-00
A23A1C1011	283-0326-00		CAP,FXD,CER DI:0.082UF,10%,50V	04222	SR205C823KAA
A23A1C1012	283-0330-00		CAP,FXD,CER DI:100PF,5%,50V	80009	283-0330-00

Replaceable Electrical Parts
494A/494AP Service Vol.2

Component No.	Tektronix Part No.	Serial/Assembly No. Effective Dscont	Name & Description	Mfr. Code	Mfr. Part No.
A23A1C1013	283-0140-00		CAP, FXD, CER DI: 4.7PF, +/-0.25PF, 50V	80009	283-0140-00
A23A1C1021	283-0159-00		CAP, FXD, CER DI: 18PF, 5%, 50V	05397	C315C180J5G5CA
A23A1C1022	283-0140-00		CAP, FXD, CER DI: 4.7PF, +/-0.25PF, 50V	80009	283-0140-00
A23A1C1023	283-0140-00		CAP, FXD, CER DI: 4.7PF, +/-0.25PF, 50V	80009	283-0140-00
A23A1C1024	283-0176-00		CAP, FXD, CER DI: 0.0022UF, 20%, 50V	04222	SR155C222MAA
A23A1C1025	283-0176-00		CAP, FXD, CER DI: 0.0022UF, 20%, 50V	04222	SR155C222MAA
A23A1C2011	283-0326-00		CAP, FXD, CER DI: 0.082UF, 10%, 50V	04222	SR205C823KAA
A23A1C2012	283-0160-00		CAP, FXD, CER DI: 1.5PF, +/-0.1PF, 50V	80009	283-0160-00
A23A1C2013	283-0158-00		CAP, FXD, CER DI: 1PF, +/-0.1PF, 50V	80009	283-0158-00
A23A1C2014	283-0176-00		CAP, FXD, CER DI: 0.0022UF, 20%, 50V	04222	SR155C222MAA
A23A1C2015	283-0176-00		CAP, FXD, CER DI: 0.0022UF, 20%, 50V	04222	SR155C222MAA
A23A1C2021	283-0159-00		CAP, FXD, CER DI: 18PF, 5%, 50V	05397	C315C180J5G5CA
A23A1C2022	283-0140-00		CAP, FXD, CER DI: 4.7PF, +/-0.25PF, 50V	80009	283-0140-00
A23A1C2023	283-0140-00		CAP, FXD, CER DI: 4.7PF, +/-0.25PF, 50V	80009	283-0140-00
A23A1C2024	283-0176-00		CAP, FXD, CER DI: 0.0022UF, 20%, 50V	04222	SR155C222MAA
A23A1CR1011	152-0738-00		SEMICON DVC, DI: VVC, SI, 30V, 1.2PF, DO-35	50101	GC-10580-15
A23A1L1011	108-0733-00		COIL, RF: FIXED, 117NH	80009	108-0733-00
A23A1L1021	108-0733-00		COIL, RF: FIXED, 117NH	80009	108-0733-00
A23A1L2010	108-0733-00		COIL, RF: FIXED, 117NH	80009	108-0733-00
A23A1L2021	108-0733-00		COIL, RF: FIXED, 117NH	80009	108-0733-00
A23A1Q1021	151-0630-00		TRANSISTOR, SIG: BIPOLAR, NPN; 12V, 70MA, 4.5GHZ, AMPLIFIER; NE02135, 4 PIN CERAMIC X PKG	S0545	NE02135
A23A1Q2014	151-0447-00		TRANSISTOR: NPN, SI, TO-72	80009	151-0447-00
A23A1Q2021	151-0630-00		TRANSISTOR, SIG: BIPOLAR, NPN; 12V, 70MA, 4.5GHZ, AMPLIFIER; NE02135, 4 PIN CERAMIC X PKG	S0545	NE02135
A23A1R1011	317-0101-00		RES, FXD, CMPSN: 100 OHM, 5%, 0.125W	80009	317-0101-00
A23A1R1020	317-0220-00		RES, FXD, CMPSN: 22 OHM, 5%, 0.125W	80009	317-0220-00
A23A1R1021	317-0750-00		RES, FXD, CMPSN: 75 OHM, 5%, 0.125W	80009	317-0750-00
A23A1R1022	317-0330-00		RES, FXD, CMPSN: 33 OHM, 5%, 0.125W	80009	317-0330-00
A23A1R1023	317-0272-00		RES, FXD, CMPSN: 2.7K OHM, 5%, 0.125W	80009	317-0272-00
A23A1R1024	315-0271-00		RES, FXD, FILM: 270 OHM, 5%, 0.25W	80009	315-0271-00
A23A1R1025	317-0471-00		RES, FXD, CMPSN: 470 OHM, 5%, 0.125W	80009	317-0471-00
A23A1R2010	317-0510-00		RES, FXD, CMPSN: 51 OHM, 5%, 0.125W	80009	317-0510-00
A23A1R2011	317-0470-00		RES, FXD, CMPSN: 47 OHM, 5%, 0.125W	80009	317-0470-00
A23A1R2012	317-0102-00		RES, FXD, CMPSN: 1K OHM, 5%, 0.125W	80009	317-0102-00
A23A1R2013	317-0241-00		RES, FXD, CMPSN: 240 OHM, 5%, 0.125W	80009	317-0241-00
A23A1R2014	317-0202-00		RES, FXD, CMPSN: 2K OHM, 5%, 0.125W	01121	BB2025
A23A1R2016	315-0271-00		RES, FXD, FILM: 270 OHM, 5%, 0.25W	80009	315-0271-00
A23A1R2021	317-0510-00		RES, FXD, CMPSN: 51 OHM, 5%, 0.125W	80009	317-0510-00
A23A1R2023	317-0272-00		RES, FXD, CMPSN: 2.7K OHM, 5%, 0.125W	80009	317-0272-00
A23A1R2024	317-0471-00		RES, FXD, CMPSN: 470 OHM, 5%, 0.125W	80009	317-0471-00
A23A1R2025	317-0241-00		RES, FXD, CMPSN: 240 OHM, 5%, 0.125W	80009	317-0241-00
A23A1R2026	317-0510-00		RES, FXD, CMPSN: 51 OHM, 5%, 0.125W	80009	317-0510-00
A23A1R2027	317-0360-00		RES, FXD, CMPSN: 36 OHM, 5%, 0.125W	80009	317-0360-00
A23A1R2028	317-0360-00		RES, FXD, CMPSN: 36 OHM, 5%, 0.125W	80009	317-0360-00
A23A1R2029	317-0301-00		RES, FXD, CMPSN: 300 OHM, 5%, 0.125W	80009	317-0301-00
A23A2	670-5937-03		CIRCUIT BD ASSY: 25MHZ PHASE LOCK	80009	670-5937-03
A23A2C1011	283-0176-00		CAP, FXD, CER DI: 0.0022UF, 20%, 50V	04222	SR155C222MAA
A23A2C1024	283-0176-00		CAP, FXD, CER DI: 0.0022UF, 20%, 50V	04222	SR155C222MAA
A23A2C1031	283-0204-00		CAP, FXD, CER DI: 0.01UF, 20%, 50V	51406	RPE110Z5U103M50V
A23A2C1037	283-0204-00		CAP, FXD, CER DI: 0.01UF, 20%, 50V	51406	RPE110Z5U103M50V
A23A2C1045	283-0204-00		CAP, FXD, CER DI: 0.01UF, 20%, 50V	51406	RPE110Z5U103M50V
A23A2C1046	283-0176-00		CAP, FXD, CER DI: 0.0022UF, 20%, 50V	04222	SR155C222MAA
A23A2C1049	283-0176-00		CAP, FXD, CER DI: 0.0022UF, 20%, 50V	04222	SR155C222MAA
A23A2C1052	290-0876-00		CAP, FXD, ELCTLT: 15UF, 20%, 25 WVDC	05397	T330C156M025AS
A23A2C1057	283-0176-00		CAP, FXD, CER DI: 0.0022UF, 20%, 50V	04222	SR155C222MAA
A23A2C2011	283-0326-00		CAP, FXD, CER DI: 0.082UF, 10%, 50V	04222	SR205C823KAA
A23A2C2012	283-0326-00		CAP, FXD, CER DI: 0.082UF, 10%, 50V	04222	SR205C823KAA

Replaceable Electrical Parts
494A/494AP Service Vol. 2

Component No.	Tektronix Part No.	Serial/Assembly No. Effective Dscort	Name & Description	Mfr. Code	Mfr. Part No.
A23A2C2021	290-0876-00		CAP, FXD, ELCTLT: 15UF, 20%, 25 WVDC	05397	T330C156M025AS
A23A2C2023	283-0326-00		CAP, FXD, CER DI: 0.082UF, 10%, 50V	04222	SR205C823KAA
A23A2C2024	290-0876-00		CAP, FXD, ELCTLT: 15UF, 20%, 25 WVDC	05397	T330C156M025AS
A23A2C2025	283-0326-00		CAP, FXD, CER DI: 0.082UF, 10%, 50V	04222	SR205C823KAA
A23A2C2032	283-0326-00		CAP, FXD, CER DI: 0.082UF, 10%, 50V	04222	SR205C823KAA
A23A2C2041	283-0176-00		CAP, FXD, CER DI: 0.0022UF, 20%, 50V	04222	SR155C222MAA
A23A2C2042	283-0204-00		CAP, FXD, CER DI: 0.01UF, 20%, 50V	51406	RPE110Z5U103M50V
A23A2C2051	283-0326-00		CAP, FXD, CER DI: 0.082UF, 10%, 50V	04222	SR205C823KAA
A23A2C2052	290-0876-00		CAP, FXD, ELCTLT: 15UF, 20%, 25 WVDC	05397	T330C156M025AS
A23A2C2053	283-0326-00		CAP, FXD, CER DI: 0.082UF, 10%, 50V	04222	SR205C823KAA
A23A2C2054	283-0326-00		CAP, FXD, CER DI: 0.082UF, 10%, 50V	04222	SR205C823KAA
A23A2C2055	283-0197-00		CAP, FXD, CER DI: 470PF, 5%, 50V	05397	C320C471J5G5CA
A23A2C2056	290-0876-00		CAP, FXD, ELCTLT: 15UF, 20%, 25 WVDC	05397	T330C156M025AS
A23A2C2057	290-0876-00		CAP, FXD, ELCTLT: 15UF, 20%, 25 WVDC	05397	T330C156M025AS
A23A2C3021	283-0326-00		CAP, FXD, CER DI: 0.082UF, 10%, 50V	04222	SR205C823KAA
A23A2C3022	283-0326-00		CAP, FXD, CER DI: 0.082UF, 10%, 50V	04222	SR205C823KAA
A23A2C3023	290-0876-00		CAP, FXD, ELCTLT: 15UF, 20%, 25 WVDC	05397	T330C156M025AS
A23A2C3031	283-0326-00		CAP, FXD, CER DI: 0.082UF, 10%, 50V	04222	SR205C823KAA
A23A2C3035	283-0326-00		CAP, FXD, CER DI: 0.082UF, 10%, 50V	04222	SR205C823KAA
A23A2C3038	290-0876-00		CAP, FXD, ELCTLT: 15UF, 20%, 25 WVDC	05397	T330C156M025AS
A23A2C3042	283-0197-00		CAP, FXD, CER DI: 470PF, 5%, 50V	05397	C320C471J5G5CA
A23A2C3043	283-0326-00		CAP, FXD, CER DI: 0.082UF, 10%, 50V	04222	SR205C823KAA
A23A2C3044	283-0326-00		CAP, FXD, CER DI: 0.082UF, 10%, 50V	04222	SR205C823KAA
A23A2C3055	283-0186-00		CAP, FXD, CER DI: 27PF, 5%, 50V	51406	RPE111NP0270J50V
A23A2C3056	283-0326-00		CAP, FXD, CER DI: 0.082UF, 10%, 50V	04222	SR205C823KAA
A23A2CR2015	152-0141-02		DIODE, SIG: ULTRA FAST; 40V, 150MA, 4NS, 2PF; 1N4152, DO-35, T&R	80009	152-0141-02
A23A2CR3025	152-0066-00		DIODE, RECT: , 400V, 1A, IFSM = 30A; GP10G, DO-41, T&R, SAFETY CONTROLLED	05828	GP10G-020
A23A2L2013	108-1140-00		COIL, RF: FXD, 1.1MH	TK1345	108-1140-00
A23A2L2018	108-1140-00		COIL, RF: FXD, 1.1MH	TK1345	108-1140-00
A23A2L2031	108-0733-00		COIL, RF: FIXED, 117NH	80009	108-0733-00
A23A2L2033	108-0733-00		COIL, RF: FIXED, 117NH	80009	108-0733-00
A23A2L3011	108-1140-00		COIL, RF: FXD, 1.1MH	TK1345	108-1140-00
A23A2L3034	108-0733-00		COIL, RF: FIXED, 117NH	80009	108-0733-00
A23A2Q2016	151-0301-00		TRANSISTOR, SIG: BIPOLAR, PNP; 60V, 600MA, 200MHZ, AMPLIFIER; 2N2907A, TO-18	80009	151-0301-00
A23A2Q2017	151-0302-00		TRANSISTOR, SIG: BIPOLAR, NPN; 40V, 800MA, 300MHZ, AMPLIFIER; 2N2222A, TO-18	80009	151-0302-00
A23A2Q3015	151-0302-00		TRANSISTOR, SIG: BIPOLAR, NPN; 40V, 800MA, 300MHZ, AMPLIFIER; 2N2222A, TO-18	80009	151-0302-00
A23A2R1021	317-0510-00		RES, FXD, CMPSN: 51 OHM, 5%, 0.125W	80009	317-0510-00
A23A2R1023	317-0510-00		RES, FXD, CMPSN: 51 OHM, 5%, 0.125W	80009	317-0510-00
A23A2R1026	317-0471-00		RES, FXD, CMPSN: 470 OHM, 5%, 0.125W	80009	317-0471-00
A23A2R1027	317-0471-00		RES, FXD, CMPSN: 470 OHM, 5%, 0.125W	80009	317-0471-00
A23A2R1029	317-0471-00		RES, FXD, CMPSN: 470 OHM, 5%, 0.125W	80009	317-0471-00
A23A2R1032	317-0047-00		RES, FXD, CMPSN: 4.7 OHM, 5%, 0.125W	80009	317-0047-00
A23A2R1033	317-0471-00		RES, FXD, CMPSN: 470 OHM, 5%, 0.125W	80009	317-0471-00
A23A2R1034	317-0047-00		RES, FXD, CMPSN: 4.7 OHM, 5%, 0.125W	80009	317-0047-00
A23A2R1035	317-0471-00		RES, FXD, CMPSN: 470 OHM, 5%, 0.125W	80009	317-0471-00
A23A2R1038	317-0471-00		RES, FXD, CMPSN: 470 OHM, 5%, 0.125W	80009	317-0471-00
A23A2R1041	317-0047-00		RES, FXD, CMPSN: 4.7 OHM, 5%, 0.125W	80009	317-0047-00
A23A2R1043	317-0471-00		RES, FXD, CMPSN: 470 OHM, 5%, 0.125W	80009	317-0471-00
A23A2R1051	317-0100-00		RES, FXD, CMPSN: 10 OHM, 5%, 0.125W	80009	317-0100-00
A23A2R1058	317-0510-00		RES, FXD, CMPSN: 51 OHM, 5%, 0.125W	80009	317-0510-00
A23A2R2014	317-0393-00		RES, FXD, CMPSN: 39K OHM, 5%, 0.125W	80009	317-0393-00
A23A2R2015	317-0203-00		RES, FXD, CMPSN: 20K OHM, 5%, 0.125W	80009	317-0203-00
A23A2R2034	317-0047-00		RES, FXD, CMPSN: 4.7 OHM, 5%, 0.125W	80009	317-0047-00

Replaceable Electrical Parts
494A/494AP Service Vol.2

Component No.	Tektronix Part No.	Serial/Assembly No. Effective Descnt	Name & Description	Mfr. Code	Mfr. Part No.
A23A2R2040	317-0471-00		RES,FXD,CMPSN:470 OHM,5%,0.125W	80009	317-0471-00
A23A2R2041	317-0102-00		RES,FXD,CMPSN:1K OHM,5%,0.125W	80009	317-0102-00
A23A2R2043	317-0471-00		RES,FXD,CMPSN:470 OHM,5%,0.125W	80009	317-0471-00
A23A2R2044	317-0102-00		RES,FXD,CMPSN:1K OHM,5%,0.125W	80009	317-0102-00
A23A2R2045	317-0102-00		RES,FXD,CMPSN:1K OHM,5%,0.125W	80009	317-0102-00
A23A2R2046	317-0471-00		RES,FXD,CMPSN:470 OHM,5%,0.125W	80009	317-0471-00
A23A2R2047	317-0471-00		RES,FXD,CMPSN:470 OHM,5%,0.125W	80009	317-0471-00
A23A2R2048	317-0361-00		RES,FXD,CMPSN:360 OHM,5%,0.125W	80009	317-0361-00
A23A2R2049	317-0471-00		RES,FXD,CMPSN:470 OHM,5%,0.125W	80009	317-0471-00
A23A2R2051	317-0470-00		RES,FXD,CMPSN:47 OHM,5%,0.125W	80009	317-0470-00
A23A2R2052	317-0510-00		RES,FXD,CMPSN:51 OHM,5%,0.125W	80009	317-0510-00
A23A2R2053	317-0101-00		RES,FXD,CMPSN:100 OHM,5%,0.125W	80009	317-0101-00
A23A2R2054	317-0101-00		RES,FXD,CMPSN:100 OHM,5%,0.125W	80009	317-0101-00
A23A2R2055	317-0101-00		RES,FXD,CMPSN:100 OHM,5%,0.125W	80009	317-0101-00
A23A2R2056	317-0361-00		RES,FXD,CMPSN:360 OHM,5%,0.125W	80009	317-0361-00
A23A2R3012	317-0303-00		RES,FXD,CMPSN:30K OHM,5%,0.125W	80009	317-0303-00
A23A2R3013	317-0203-00		RES,FXD,CMPSN:20K OHM,5%,0.125W	80009	317-0203-00
A23A2R3014	317-0752-00		RES,FXD,CMPSN:7.5K OHM,5%,0.125W	80009	317-0752-00
A23A2R3016	317-0752-00		RES,FXD,CMPSN:7.5K OHM,5%,0.125W	80009	317-0752-00
A23A2R3037	317-0101-00		RES,FXD,CMPSN:100 OHM,5%,0.125W	80009	317-0101-00
A23A2R3041	317-0361-00		RES,FXD,CMPSN:360 OHM,5%,0.125W	80009	317-0361-00
A23A2R3045	317-0361-00		RES,FXD,CMPSN:360 OHM,5%,0.125W	80009	317-0361-00
A23A2R3046	317-0471-00		RES,FXD,CMPSN:470 OHM,5%,0.125W	80009	317-0471-00
A23A2R3051	317-0332-00		RES,FXD,CMPSN:3.3K OHM,5%,0.125W	80009	317-0332-00
A23A2R3052	317-0752-00		RES,FXD,CMPSN:7.5K OHM,5%,0.125W	80009	317-0752-00
A23A2R3054	317-0100-00		RES,FXD,CMPSN:10 OHM,5%,0.125W	80009	317-0100-00
A23A2U1022	156-0860-00		IC,DIGITAL:ECL,RECEIVER;TRIPLE LINE;10116.D IP16.3,TUBE	80009	156-0860-00
A23A2U1036	156-0230-00		IC,DIGITAL:ECL,FLIP FLOP;DUAL D-TYPE MASTER SLAVE;10131,DIP16.3,TUBE	80009	156-0230-00
A23A2U1044	156-0860-00		IC,DIGITAL:ECL,RECEIVER;TRIPLE LINE;10116.D IP16.3,TUBE	80009	156-0860-00
A23A2U1053	156-0074-00		IC,LINEAR:BIPOLAR,AMPLIFIER;DIFFERENTIAL IN PUT & OUTPUT,120MHZ;LM733CH/MC1733CG,TO-100	80009	156-0074-00
A23A2U2047	156-0230-00		IC,DIGITAL:ECL,FLIP FLOP;DUAL D-TYPE MASTER SLAVE;10131,DIP16.3,TUBE	80009	156-0230-00
A23A2U3053	156-0742-02		IC,LINEAR:BIPOLAR,OP-AMP;DUPLICATE OF 156-0 742-00,DO NOT USE;LM318N,DIP08.3	80009	156-0742-02
A23A2VR1048	152-0647-00		DIODE,ZENER:;6.8V,5%,0.4W;1N957B,DO-7 OR 3 5,TR	04713	1N957B
A23A3	670-6016-00		CIRCUIT BD ASSY:829MHZ HARMONIC MIXER	80009	670-6016-00
A23A3C1021	283-0140-00		CAP,FXD,CER DI:4.7PF,+/-0.25PF,50V	80009	283-0140-00
A23A3C1022	283-0140-00		CAP,FXD,CER DI:4.7PF,+/-0.25PF,50V	80009	283-0140-00
A23A3C1023	283-0140-00		CAP,FXD,CER DI:4.7PF,+/-0.25PF,50V	80009	283-0140-00
A23A3C2021	283-0159-00		CAP,FXD,CER DI:18PF,5%,50V	05397	C315C180J565CA
A23A3C2023	283-0140-00		CAP,FXD,CER DI:4.7PF,+/-0.25PF,50V	80009	283-0140-00
A23A3C2024	283-0140-00		CAP,FXD,CER DI:4.7PF,+/-0.25PF,50V	80009	283-0140-00
A23A3C3011	283-0326-00		CAP,FXD,CER DI:0.082UF,10%,50V	04222	SR205C823KAA
A23A3C3013	283-0176-00		CAP,FXD,CER DI:0.0022UF,20%,50V	04222	SR155C222MAA
A23A3C3014	283-0159-00		CAP,FXD,CER DI:18PF,5%,50V	05397	C315C180J565CA
A23A3C3020	283-0176-00		CAP,FXD,CER DI:0.0022UF,20%,50V	04222	SR155C222MAA
A23A3C3021	283-0176-00		CAP,FXD,CER DI:0.0022UF,20%,50V	04222	SR155C222MAA
A23A3C3022	283-0140-00		CAP,FXD,CER DI:4.7PF,+/-0.25PF,50V	80009	283-0140-00
A23A3C3023	283-0140-00		CAP,FXD,CER DI:4.7PF,+/-0.25PF,50V	80009	283-0140-00
A23A3C3024	283-0159-00		CAP,FXD,CER DI:18PF,5%,50V	05397	C315C180J565CA
A23A3C3025	283-0140-00		CAP,FXD,CER DI:4.7PF,+/-0.25PF,50V	80009	283-0140-00
A23A3CR2021	152-0322-00		DIODE,SIG:SCHTKY,;15V,410MVF AT 1MA,1.2PF;5 082-2811,T&R	80009	152-0322-00

Replaceable Electrical Parts
494A/494AP Service Vol.2

Component No.	Tektronix	Serial/Assembly No.		Name & Description	Mfr.	Mfr. Part No.
	Part No.	Effective	Dscont		Code	
A23A3CR3011	152-0322-00			DIODE, SIG: SCHKY, ;15V, 410MVF AT 1MA, 1.2PF; 5 082-2811, T&R	80009	152-0322-00
A23A3L2014	108-0643-00			COIL, RF: FIXED, 44 NH ON FORM276-0145-00	80009	108-0643-00
A23A3L3011	108-0733-00			COIL, RF: FIXED, 117NH	80009	108-0733-00
A23A3L3012	108-0215-00			COIL, RF: FIXED, 1.1UH	TK1345	108-0215-00
A23A3L3014	108-0733-00			COIL, RF: FIXED, 117NH	80009	108-0733-00
A23A3L3021	108-0733-00			COIL, RF: FIXED, 117NH	80009	108-0733-00
A23A3Q3021	151-0630-00			TRANSISTOR, SIG: BIPOLAR, NPN; 12V, 70MA, 4.5GHZ, AMPLIFIER; NEO2135, 4 PIN CERAMIC X PKG	S0545	NEO2135
A23A3R1021	317-0820-00			RES, FXD, CMPSN: 82 OHM, 5%, 0.125W	80009	317-0820-00
A23A3R1022	317-0820-00			RES, FXD, CMPSN: 82 OHM, 5%, 0.125W	80009	317-0820-00
A23A3R1023	317-0430-00			RES, FXD, CMPSN: 43 OHM, 5%, 0.125W	80009	317-0430-00
A23A3R2021	317-0301-00			RES, FXD, CMPSN: 300 OHM, 5%, 0.125W	80009	317-0301-00
A23A3R2022	317-0160-00			RES, FXD, CMPSN: 16 OHM, 5%, 0.125W	80009	317-0160-00
A23A3R2023	317-0680-00			RES, FXD, CMPSN: 68 OHM, 5%, 0.125W	80009	317-0680-00
A23A3R2024	317-0430-00			RES, FXD, CMPSN: 43 OHM, 5%, 0.125W	80009	317-0430-00
A23A3R2025	317-0820-00			RES, FXD, CMPSN: 82 OHM, 5%, 0.125W	80009	317-0820-00
A23A3R2026	317-0820-00			RES, FXD, CMPSN: 82 OHM, 5%, 0.125W	80009	317-0820-00
A23A3R2027	317-0680-00			RES, FXD, CMPSN: 68 OHM, 5%, 0.125W	80009	317-0680-00
A23A3R2028	317-0160-00			RES, FXD, CMPSN: 16 OHM, 5%, 0.125W	80009	317-0160-00
A23A3R3010	317-0222-00			RES, FXD, CMPSN: 2.2K OHM, 5%, 0.125W	80009	317-0222-00
A23A3R3011	315-0271-00			RES, FXD, FILM: 270 OHM, 5%, 0.25W	80009	315-0271-00
A23A3R3012	317-0101-00			RES, FXD, CMPSN: 100 OHM, 5%, 0.125W	80009	317-0101-00
A23A3R3021	317-0360-00			RES, FXD, CMPSN: 36 OHM, 5%, 0.125W	80009	317-0360-00
A23A3R3022	317-0360-00			RES, FXD, CMPSN: 36 OHM, 5%, 0.125W	80009	317-0360-00
A23A3R3023	317-0301-00			RES, FXD, CMPSN: 300 OHM, 5%, 0.125W	80009	317-0301-00
A23A3R3024	317-0471-00			RES, FXD, CMPSN: 470 OHM, 5%, 0.125W	80009	317-0471-00
A23A3R3025	317-0272-00			RES, FXD, CMPSN: 2.7K OHM, 5%, 0.125W	80009	317-0272-00
A23A3R3027	317-0750-00			RES, FXD, CMPSN: 75 OHM, 5%, 0.125W	80009	317-0750-00
A23A3R3028	317-0510-00			RES, FXD, CMPSN: 51 OHM, 5%, 0.125W	80009	317-0510-00
A23A3R3029	317-0750-00			RES, FXD, CMPSN: 75 OHM, 5%, 0.125W	80009	317-0750-00
A23A4	670-6256-03			CIRCUIT BD ASSY: 829MHZ DIPLEXER	80009	670-6256-03
A23A4C1010	283-0158-00			CAP, FXD, CER DI: 1PF, +/-0.1PF, 50V	80009	283-0158-00
A23A4C1011	283-0158-00			CAP, FXD, CER DI: 1PF, +/-0.1PF, 50V	80009	283-0158-00
A23A4C1012	283-0203-00			CAP, FXD, CER DI: 0.47UF, 20%, 50V	80009	283-0203-00
A23A4C1013	283-0158-00			CAP, FXD, CER DI: 1PF, +/-0.1PF, 50V	80009	283-0158-00
A23A4C1014	283-0158-00			CAP, FXD, CER DI: 1PF, +/-0.1PF, 50V	80009	283-0158-00
A23A4C1015	283-0160-00			CAP, FXD, CER DI: 1.5PF, +/-0.1PF, 50V	80009	283-0160-00
A23A4C1016	283-0326-00			CAP, FXD, CER DI: 0.082UF, 10%, 50V	04222	SR205C823KAA
A23A4C1017	283-0326-00			CAP, FXD, CER DI: 0.082UF, 10%, 50V	04222	SR205C823KAA
A23A4C1018	283-0326-00			CAP, FXD, CER DI: 0.082UF, 10%, 50V	04222	SR205C823KAA
A23A4C1019	283-0326-00			CAP, FXD, CER DI: 0.082UF, 10%, 50V	04222	SR205C823KAA
A23A4C1021	283-0158-00			CAP, FXD, CER DI: 1PF, +/-0.1PF, 50V	80009	283-0158-00
A23A4L1010	108-1043-00			COIL, RF: FXD, 2MH	80009	108-1043-00
A23A4L1011	108-0598-00			COIL, RF: FIXED, 200UH	80009	108-0598-00
A23A4L1012	108-0642-00			COIL, RF: FIXED, 30NH, +/-15%, FORM 276-0145-00	80009	108-0642-00
A23A4L1015	108-0642-00			COIL, RF: FIXED, 30NH, +/-15%, FORM 276-0145-00	80009	108-0642-00
A23A4R1011	317-0101-00			RES, FXD, CMPSN: 100 OHM, 5%, 0.125W	80009	317-0101-00
A23A4R1012	317-0101-00			RES, FXD, CMPSN: 100 OHM, 5%, 0.125W	80009	317-0101-00
A23A4R1013	317-0200-00			RES, FXD, CMPSN: 20 OHM, 5%, 0.125W	80009	317-0200-00
A23A4R1014	317-0101-00			RES, FXD, CMPSN: 100 OHM, 5%, 0.125W	80009	317-0101-00
A23A4R1015	317-0101-00			RES, FXD, CMPSN: 100 OHM, 5%, 0.125W	80009	317-0101-00
A23A5	670-6255-01			CIRCUIT BD ASSY: 829MHZ AMPL	80009	670-6255-01
A23A5C1011	283-0326-00			CAP, FXD, CER DI: 0.082UF, 10%, 50V	04222	SR205C823KAA
A23A5C1012	283-0326-00			CAP, FXD, CER DI: 0.082UF, 10%, 50V	04222	SR205C823KAA
A23A5C1013	283-0326-00			CAP, FXD, CER DI: 0.082UF, 10%, 50V	04222	SR205C823KAA
A23A5C1014	283-0197-00			CAP, FXD, CER DI: 470PF, 5%, 50V	05397	C320C471J565CA
A23A5C1015	283-0160-00			CAP, FXD, CER DI: 1.5PF, +/-0.1PF, 50V	80009	283-0160-00

Replaceable Electrical Parts
494A/494AP Service Vol. 2

Component No.	Tektronix Part No.	Serial/Assembly No. Effective Dscmt	Name & Description	Mfr. Code	Mfr. Part No.
A23A5C1016	283-0197-00		CAP, FXD, CER DI: 470PF, 5%, 50V	05397	C320C471J5G5CA
A23A5C1017	283-0160-00		CAP, FXD, CER DI: 1.5PF, +/-0.1PF, 50V	80009	283-0160-00
A23A5C1018	283-0140-00		CAP, FXD, CER DI: 4.7PF, +/-0.25PF, 50V	80009	283-0140-00
A23A5C1021	283-0160-00		CAP, FXD, CER DI: 1.5PF, +/-0.1PF, 50V	80009	283-0160-00
A23A5C1022	283-0160-00		CAP, FXD, CER DI: 1.5PF, +/-0.1PF, 50V	80009	283-0160-00
A23A5C1023	283-0197-00		CAP, FXD, CER DI: 470PF, 5%, 50V	05397	C320C471J5G5CA
A23A5C1024	283-0326-00		CAP, FXD, CER DI: 0.082UF, 10%, 50V	04222	SR205C823KAA
A23A5C1025	283-0326-00		CAP, FXD, CER DI: 0.082UF, 10%, 50V	04222	SR205C823KAA
A23A5C1026	283-0140-00		CAP, FXD, CER DI: 4.7PF, +/-0.25PF, 50V	80009	283-0140-00
A23A5C1027	283-0326-00		CAP, FXD, CER DI: 0.082UF, 10%, 50V	04222	SR205C823KAA
A23A5C1029	283-0326-00		CAP, FXD, CER DI: 0.082UF, 10%, 50V	04222	SR205C823KAA
A23A5CR1013	152-0141-02		DIODE, SIG: ULTRA FAST; 40V, 150MA, 4NS, 2PF; 1N4152, DO-35, T&R	80009	152-0141-02
A23A5CR1022	152-0141-02		DIODE, SIG: ULTRA FAST; 40V, 150MA, 4NS, 2PF; 1N4152, DO-35, T&R	80009	152-0141-02
A23A5J1029	131-1003-00		CONN, RCPT, ELEC: CKT BD MT, 3 PRONG	80009	131-1003-00
A23A5L1011	108-0733-00		COIL, RF: FIXED, 117NH	80009	108-0733-00
A23A5L1012	108-0733-00		COIL, RF: FIXED, 117NH	80009	108-0733-00
A23A5L1014	108-0733-00		COIL, RF: FIXED, 117NH	80009	108-0733-00
A23A5L1021	108-0733-00		COIL, RF: FIXED, 117NH	80009	108-0733-00
A23A5L1024	108-0733-00		COIL, RF: FIXED, 117NH	80009	108-0733-00
A23A5L1025	108-0733-00		COIL, RF: FIXED, 117NH	80009	108-0733-00
A23A5L1029	108-0733-00		COIL, RF: FIXED, 117NH	80009	108-0733-00
A23A5Q1017	151-0630-00		TRANSISTOR, SIG: BIPOLAR, NPN; 12V, 70MA, 4.5GHZ, AMPLIFIER; NE02135, 4 PIN CERAMIC X PKG	S0545	NE02135
A23A5Q1025	151-0630-00		TRANSISTOR, SIG: BIPOLAR, NPN; 12V, 70MA, 4.5GHZ, AMPLIFIER; NE02135, 4 PIN CERAMIC X PKG	S0545	NE02135
A23A5R1011	321-0234-00		RES, FXD, FILM: 2.67K OHM, 1%, 0.125W, TC=TO	80009	321-0234-00
A23A5R1012	321-0202-00		RES, FXD, FILM: 1.24K OHM, 1%, 0.125W, TC=TO	19701	5043ED1K240F
A23A5R1013	317-0511-00		RES, FXD, CMPSN: 510 OHM, 5%, 0.125W	80009	317-0511-00
A23A5R1014	317-0511-00		RES, FXD, CMPSN: 510 OHM, 5%, 0.125W	80009	317-0511-00
A23A5R1015	317-0151-00		RES, FXD, CMPSN: 150 OHM, 5%, 0.125W	80009	317-0151-00
A23A5R1016	317-0201-00		RES, FXD, CMPSN: 200 OHM, 5%, 0.125W	80009	317-0201-00
A23A5R1020	317-0201-00		RES, FXD, CMPSN: 200 OHM, 5%, 0.125W	80009	317-0201-00
A23A5R1021	321-0202-00		RES, FXD, FILM: 1.24K OHM, 1%, 0.125W, TC=TO	19701	5043ED1K240F
A23A5R1022	321-0234-00		RES, FXD, FILM: 2.67K OHM, 1%, 0.125W, TC=TO	80009	321-0234-00
A23A5R1023	317-0151-00		RES, FXD, CMPSN: 150 OHM, 5%, 0.125W	80009	317-0151-00
A23A5R1024	317-0331-00		RES, FXD, CMPSN: 330 OHM, 5%, 0.125W	80009	317-0331-00
A23A5R1025	317-0331-00		RES, FXD, CMPSN: 330 OHM, 5%, 0.125W	80009	317-0331-00
A23A5R1026	317-0360-00		RES, FXD, CMPSN: 36 OHM, 5%, 0.125W	80009	317-0360-00
A23A5R1027	317-0360-00		RES, FXD, CMPSN: 36 OHM, 5%, 0.125W	80009	317-0360-00
A23A5R1028	317-0301-00		RES, FXD, CMPSN: 300 OHM, 5%, 0.125W	80009	317-0301-00
A23A5R1029	317-0301-00		RES, FXD, CMPSN: 300 OHM, 5%, 0.125W	80009	317-0301-00
A23A6	670-6015-01		CIRCUIT BD ASSY: 110MHZ IF SELECT	80009	670-6015-01
A23A6C1011	283-0197-00		CAP, FXD, CER DI: 470PF, 5%, 50V	05397	C320C471J5G5CA
A23A6C1012	283-0197-00		CAP, FXD, CER DI: 470PF, 5%, 50V	05397	C320C471J5G5CA
A23A6C1013	283-0326-00		CAP, FXD, CER DI: 0.082UF, 10%, 50V	04222	SR205C823KAA
A23A6C1014	283-0220-00		CAP, FXD, CER DI: 0.01UF, 20%, 50V	04222	SR205C103MAA
A23A6C1015	283-0220-00		CAP, FXD, CER DI: 0.01UF, 20%, 50V	04222	SR205C103MAA
A23A6C1016	283-0326-00		CAP, FXD, CER DI: 0.082UF, 10%, 50V	04222	SR205C823KAA
A23A6C1017	283-0326-00		CAP, FXD, CER DI: 0.082UF, 10%, 50V	04222	SR205C823KAA
A23A6C1018	283-0326-00		CAP, FXD, CER DI: 0.082UF, 10%, 50V	04222	SR205C823KAA
A23A6C2011	283-0220-00		CAP, FXD, CER DI: 0.01UF, 20%, 50V	04222	SR205C103MAA
A23A6C2012	283-0159-00		CAP, FXD, CER DI: 18PF, 5%, 50V	05397	C315C180J5G5CA
A23A6C2013	283-0197-00		CAP, FXD, CER DI: 470PF, 5%, 50V	05397	C320C471J5G5CA
A23A6C2014	283-0197-00		CAP, FXD, CER DI: 470PF, 5%, 50V	05397	C320C471J5G5CA
A23A6C2015	283-0220-00		CAP, FXD, CER DI: 0.01UF, 20%, 50V	04222	SR205C103MAA
A23A6C2016	283-0220-00		CAP, FXD, CER DI: 0.01UF, 20%, 50V	04222	SR205C103MAA

Replaceable Electrical Parts
494A/494AP Service Vol.2

Component No.	Tektronix Part No.	Serial/Assembly No.		Name & Description	Mfr. Code	Mfr. Part No.
		Effective	Dscont			
A23A6C2017	283-0154-00			CAP,FXD,CER DI:22PF,5%,50V	05397	C315C220J5G5CA
A23A6CR1011	152-0141-02			DIODE,SIG:ULTRA FAST;40V,150MA,4NS,2PF;1N4 152,DO-35,T&R	80009	152-0141-02
A23A6CR1015	152-0141-02			DIODE,SIG:ULTRA FAST;40V,150MA,4NS,2PF;1N4 152,DO-35,T&R	80009	152-0141-02
A23A6CR2011	152-0141-02			DIODE,SIG:ULTRA FAST;40V,150MA,4NS,2PF;1N4 152,DO-35,T&R	80009	152-0141-02
A23A6CR2012	152-0141-02			DIODE,SIG:ULTRA FAST;40V,150MA,4NS,2PF;1N4 152,DO-35,T&R	80009	152-0141-02
A23A6CR2013	152-0141-02			DIODE,SIG:ULTRA FAST;40V,150MA,4NS,2PF;1N4 152,DO-35,T&R	80009	152-0141-02
A23A6CR2015	152-0141-02			DIODE,SIG:ULTRA FAST;40V,150MA,4NS,2PF;1N4 152,DO-35,T&R	80009	152-0141-02
A23A6L1014	108-0341-00			COIL,RF:FIXED,1.4UH	80009	108-0341-00
A23A6L1015	108-0733-00			COIL,RF:FIXED,117NH	80009	108-0733-00
A23A6L1018	108-0733-00			COIL,RF:FIXED,117NH	80009	108-0733-00
A23A6L1019	108-0733-00			COIL,RF:FIXED,117NH	80009	108-0733-00
A23A6L2011	108-0733-00			COIL,RF:FIXED,117NH	80009	108-0733-00
A23A6L2013	108-0733-00			COIL,RF:FIXED,117NH	80009	108-0733-00
A23A6L2014	108-0311-00			COIL,RF:FIXED,150NH	TK1345	108-0311-00
A23A6L2015	108-0341-00			COIL,RF:FIXED,1.4UH	80009	108-0341-00
A23A6Q1011	151-0630-00			TRANSISTOR,SIG:BIPOLAR,NPN;12V,70MA,4.5GHZ, AMPLIFIER;NEO2135,4 PIN CERAMIC X PKG	S0545	NEO2135
A23A6Q1012	151-0301-00			TRANSISTOR,SIG:BIPOLAR,PNP;60V,600MA,200MHZ ,AMPLIFIER;2N2907A,TO-18	80009	151-0301-00
A23A6Q2015	151-0301-00			TRANSISTOR,SIG:BIPOLAR,PNP;60V,600MA,200MHZ ,AMPLIFIER;2N2907A,TO-18	80009	151-0301-00
A23A6R1010	317-0472-00			RES,FXD,CMPSN:4.7K OHM,5%,0.125W	80009	317-0472-00
A23A6R1011	317-0056-00			RES,FXD,CMPSN:5.6 OHM,5%,0.125W	80009	317-0056-00
A23A6R1012	317-0911-00			RES,FXD,CMPSN:910 OHM,5%,0.125W	80009	317-0911-00
A23A6R1013	317-0910-00			RES,FXD,CMPSN:91 OHM,5%,0.125W	80009	317-0910-00
A23A6R1014	317-0822-00			RES,FXD,CMPSN:8.2K OHM,5%,0.125W	80009	317-0822-00
A23A6R1015	317-0153-00			RES,FXD,CMPSN:15K OHM,5%,0.125W	80009	317-0153-00
A23A6R1016	317-0752-00			RES,FXD,CMPSN:7.5K OHM,5%,0.125W	80009	317-0752-00
A23A6R1017	317-0201-00			RES,FXD,CMPSN:200 OHM,5%,0.125W	80009	317-0201-00
A23A6R1018	317-0331-00			RES,FXD,CMPSN:330 OHM,5%,0.125W	80009	317-0331-00
A23A6R1019	317-0203-00			RES,FXD,CMPSN:20K OHM,5%,0.125W	80009	317-0203-00
A23A6R2015	317-0181-00			RES,FXD,CMPSN:180 OHM,5%,0.125W	01121	BB1815
A23A7	670-6224-00			CIRCUIT BD ASSY:829MHZ,SECOND CONVERTER	80009	670-6224-00
A23A7C1011	283-0140-00			CAP,FXD,CER DI:4.7PF,+/-0.25PF,50V	80009	283-0140-00
A23A7C1012	283-0140-00			CAP,FXD,CER DI:4.7PF,+/-0.25PF,50V	80009	283-0140-00
A23A7C1013	283-0069-00			CAP,FXD,CER DI:15PF,20%,50V	80009	283-0069-00
A23A7C1014	283-0069-00			CAP,FXD,CER DI:15PF,20%,50V	80009	283-0069-00
A23A7CR1011	152-0322-00			DIODE,SIG:SCHTKY,;15V,410MVF AT 1MA,1.2PF;5 082-2811,T&R	80009	152-0322-00
A23A7CR1012	152-0322-00			DIODE,SIG:SCHTKY,;15V,410MVF AT 1MA,1.2PF;5 082-2811,T&R	80009	152-0322-00
A23A7L1011	108-0606-00			COIL,RF:	80009	108-0606-00
A23A7L1012	108-0606-00			COIL,RF:	80009	108-0606-00
A23A7L1013	108-0606-00			COIL,RF:	80009	108-0606-00
A23A7L1014	108-0606-00			COIL,RF:	80009	108-0606-00
A23A7R1012	317-0301-00			RES,FXD,CMPSN:300 OHM,5%,0.125W	80009	317-0301-00
A23A7R1013	317-0360-00			RES,FXD,CMPSN:36 OHM,5%,0.125W	80009	317-0360-00
A23A7R1014	317-0360-00			RES,FXD,CMPSN:36 OHM,5%,0.125W	80009	317-0360-00
A23A7R1015	317-0301-00			RES,FXD,CMPSN:300 OHM,5%,0.125W	80009	317-0301-00
A23A7T1011	120-1251-00			TRANSFORMER,RF:BALUN	80009	120-1251-00
A24	119-1010-02			HYBRID CKT ASSY:PHASE GATE DETECTOR	80009	119-1010-02
A24A1	670-5957-01			CIRCUIT BD ASSY:PHASE GATE INPUT	80009	670-5957-01

Replaceable Electrical Parts
494A/494AP Service Vol.2

Component No.	Tektronix Part No.	Serial/Assembly No. Effective	Dscont	Name & Description	Mfr. Code	Mfr. Part No.
A24A1C243	290-0747-00			CAP, FXD, ELCTLT: 100UF, +50-20%, 25WVDC	24165	516D107M025LM7B
A24A1C244	290-0747-00			CAP, FXD, ELCTLT: 100UF, +50-20%, 25WVDC	24165	516D107M025LM7B
A24A1R243	315-0200-00			RES, FXD, FILM: 20 OHM, 5%, 0.25W	80009	315-0200-00
A24A1R244	315-0200-00			RES, FXD, FILM: 20 OHM, 5%, 0.25W	80009	315-0200-00
A25	119-1640-01	B010100	B020706	HARMONIC MIXER:	80009	119-1640-01
A25	119-1640-02	B020707		HARMONIC MIXER: 494AP	80009	119-1640-02
A25W252	175-8739-00			CA ASSY, SP, ELEC: 3, 26 AWG, 3.0 L, RIBBON	TK1375	175-8739-00
A25A3	670-4376-01	B010100	B020668	CIRCUIT BD ASSY: HARMONIC MIXER INPUT	80009	670-4376-01
A25A3	670-5957-01	B020668		CIRCUIT BD ASSY: PHASE GATE INPUT	80009	670-5957-01
A25A3C243	290-0747-00			CAP, FXD, ELCTLT: 100UF, +50-20%, 25WVDC	24165	516D107M025LM7B
A25A3C244	290-0747-00			CAP, FXD, ELCTLT: 100UF, +50-20%, 25WVDC	24165	516D107M025LM7B
A25A3R243	315-0100-00	B010100	B020668	RES, FXD, FILM: 10 OHM, 5%, 0.25W	19701	5043CX10RR00J
A25A3R243	315-0200-00	B020669		RES, FXD, FILM: 20 OHM, 5%, 0.25W	80009	315-0200-00
A25A3R244	315-0100-00	B010100	B020668	RES, FXD, FILM: 10 OHM, 5%, 0.25W	19701	5043CX10RR00J
A25A3R244	315-0200-00	B020669		RES, FXD, FILM: 20 OHM, 5%, 0.25W	80009	315-0200-00
A26	672-0160-00			CIRCUIT BD ASSY: AUX SYNTHESIZER	80009	672-0160-00
A26A1	670-9163-00			CIRCUIT BD ASSY: AUX SYNTH	80009	670-9163-00
A26A1C1016	283-0220-00			CAP, FXD, CER DI: 0.01UF, 20%, 50V	04222	SR205C103MAA
A26A1C1020	283-0109-00			CAP, FXD, CER DI: 27PF, 5%, 1000V	80009	283-0109-00
A26A1C1021	283-0220-00			CAP, FXD, CER DI: 0.01UF, 20%, 50V	04222	SR205C103MAA
A26A1C1023	283-0220-00			CAP, FXD, CER DI: 0.01UF, 20%, 50V	04222	SR205C103MAA
A26A1C1024	283-0333-00			CAP, FXD, CER DI: 35PF, 5%, 1000V	72982	838-534 A 350>
A26A1C1046	283-0024-00			CAP, FXD, CER DI: 0.1UF, +80-20%, 50V	05397	C330C10Y25U1CA
A26A1C1055	283-0024-00			CAP, FXD, CER DI: 0.1UF, +80-20%, 50V	05397	C330C10Y25U1CA
A26A1C1057	283-0024-00			CAP, FXD, CER DI: 0.1UF, +80-20%, 50V	05397	C330C10Y25U1CA
A26A1C1066	283-0156-00			CAP, FXD, CER DI: 1000PF, +80-20%, 200V	04222	SR152E102ZAA
A26A1C1070	281-0165-00			CAP, VAR, AIR DI: 0.8-10PF, 250V	80009	281-0165-00
A26A1C2012	283-0024-00			CAP, FXD, CER DI: 0.1UF, +80-20%, 50V	05397	C330C10Y25U1CA
A26A1C2013	283-0220-00			CAP, FXD, CER DI: 0.01UF, 20%, 50V	04222	SR205C103MAA
A26A1C2019	283-0330-00			CAP, FXD, CER DI: 100PF, 5%, 50V	80009	283-0330-00
A26A1C2021	283-0220-00			CAP, FXD, CER DI: 0.01UF, 20%, 50V	04222	SR205C103MAA
A26A1C2022	283-0220-00			CAP, FXD, CER DI: 0.01UF, 20%, 50V	04222	SR205C103MAA
A26A1C2024	283-0156-00			CAP, FXD, CER DI: 1000PF, +80-20%, 200V	04222	SR152E102ZAA
A26A1C2040	283-0024-00			CAP, FXD, CER DI: 0.1UF, +80-20%, 50V	05397	C330C10Y25U1CA
A26A1C2046	283-0024-00			CAP, FXD, CER DI: 0.1UF, +80-20%, 50V	05397	C330C10Y25U1CA
A26A1C2047	283-0220-00			CAP, FXD, CER DI: 0.01UF, 20%, 50V	04222	SR205C103MAA
A26A1C2052	283-0156-00			CAP, FXD, CER DI: 1000PF, +80-20%, 200V	04222	SR152E102ZAA
A26A1C2053	283-0024-00			CAP, FXD, CER DI: 0.1UF, +80-20%, 50V	05397	C330C10Y25U1CA
A26A1C2054	283-0156-00			CAP, FXD, CER DI: 1000PF, +80-20%, 200V	04222	SR152E102ZAA
A26A1C2055	283-0024-00			CAP, FXD, CER DI: 0.1UF, +80-20%, 50V	05397	C330C10Y25U1CA
A26A1C2056	283-0220-00			CAP, FXD, CER DI: 0.01UF, 20%, 50V	04222	SR205C103MAA
A26A1C2059	283-0156-00			CAP, FXD, CER DI: 1000PF, +80-20%, 200V	04222	SR152E102ZAA
A26A1C2061	283-0156-00			CAP, FXD, CER DI: 1000PF, +80-20%, 200V	04222	SR152E102ZAA
A26A1C2065	283-0201-00			CAP, FXD, CER DI: 27PF, 10%, 200V	04222	SR152C270KAA
A26A1C2066	283-0156-00			CAP, FXD, CER DI: 1000PF, +80-20%, 200V	04222	SR152E102ZAA
A26A1C2067	283-0220-00			CAP, FXD, CER DI: 0.01UF, 20%, 50V	04222	SR205C103MAA
A26A1C2068	283-0140-00			CAP, FXD, CER DI: 4.7PF, +/-0.25PF, 50V	80009	283-0140-00
A26A1C2069	283-0108-00			CAP, FXD, CER DI: 220PF, 10%, 200V	04222	SR152A221KAA
A26A1C2071	283-0201-00			CAP, FXD, CER DI: 27PF, 10%, 200V	04222	SR152C270KAA
A26A1C2072	283-0140-00			CAP, FXD, CER DI: 4.7PF, +/-0.25PF, 50V	80009	283-0140-00
A26A1C2073	283-0220-00			CAP, FXD, CER DI: 0.01UF, 20%, 50V	04222	SR205C103MAA
A26A1C2075	283-0220-00			CAP, FXD, CER DI: 0.01UF, 20%, 50V	04222	SR205C103MAA
A26A1C3012	283-0869-00			CAP, FXD, CER DI: 68PF, NPO, 100V, 1%	80009	283-0869-00
A26A1C3016	283-0472-00			CAP, FXD, CER DI: 102PF, 1%, 50V	04222	SR205AVEDFAA
A26A1C3018	283-0472-00			CAP, FXD, CER DI: 102PF, 1%, 50V	04222	SR205AVEDFAA
A26A1C3022	283-0869-00			CAP, FXD, CER DI: 68PF, NPO, 100V, 1%	80009	283-0869-00
A26A1C3032	285-0598-00			CAP, FXD, PLASTIC: 0.01UF, 5%, 100V	19396	DU490B103J
A26A1C3035	285-0598-00			CAP, FXD, PLASTIC: 0.01UF, 5%, 100V	19396	DU490B103J

Replaceable Electrical Parts
494A/494AP Service Vol.2

Component No.	Tektronix	Serial/Assembly No.		Name & Description	Mfr.	Mfr. Part No.
	Part No.	Effective	Discont		Code	
A26A1C3046	283-0330-00			CAP,FXD,CER DI:100PF,5%,50V	80009	283-0330-00
A26A1C3047	283-0330-00			CAP,FXD,CER DI:100PF,5%,50V	80009	283-0330-00
A26A1C3050	283-0220-00			CAP,FXD,CER DI:0.01UF,20%,50V	04222	SR205C103MAA
A26A1C3051	283-0156-00			CAP,FXD,CER DI:1000PF,+80-20%,200V	04222	SR152E102ZAA
A26A1C3052	283-0024-00			CAP,FXD,CER DI:0.1UF,+80-20%,50V	05397	C330C10YZ5U1CA
A26A1C3058	283-0024-00			CAP,FXD,CER DI:0.1UF,+80-20%,50V	05397	C330C10YZ5U1CA
A26A1C3066	283-0024-00			CAP,FXD,CER DI:0.1UF,+80-20%,50V	05397	C330C10YZ5U1CA
A26A1C3067	290-0804-00			CAP,FXD,ELCTLT:10UF,+50-20%,25V	80009	290-0804-00
A26A1C3071	283-0220-00			CAP,FXD,CER DI:0.01UF,20%,50V	04222	SR205C103MAA
A26A1C3074	283-0024-00			CAP,FXD,CER DI:0.1UF,+80-20%,50V	05397	C330C10YZ5U1CA
A26A1C4014	283-0024-00			CAP,FXD,CER DI:0.1UF,+80-20%,50V	05397	C330C10YZ5U1CA
A26A1C4017	283-0220-00			CAP,FXD,CER DI:0.01UF,20%,50V	04222	SR205C103MAA
A26A1C4021	283-0024-00			CAP,FXD,CER DI:0.1UF,+80-20%,50V	05397	C330C10YZ5U1CA
A26A1C4026	283-0220-00			CAP,FXD,CER DI:0.01UF,20%,50V	04222	SR205C103MAA
A26A1C4027	283-0220-00			CAP,FXD,CER DI:0.01UF,20%,50V	04222	SR205C103MAA
A26A1C4032	285-0598-00			CAP,FXD,PLASTIC:0.01UF,5%,100V	19396	DU490B103J
A26A1C4035	285-0598-00			CAP,FXD,PLASTIC:0.01UF,5%,100V	19396	DU490B103J
A26A1C4037	283-0024-00			CAP,FXD,CER DI:0.1UF,+80-20%,50V	05397	C330C10YZ5U1CA
A26A1C4053	283-0220-00			CAP,FXD,CER DI:0.01UF,20%,50V	04222	SR205C103MAA
A26A1C5015	283-0024-00			CAP,FXD,CER DI:0.1UF,+80-20%,50V	05397	C330C10YZ5U1CA
A26A1C5016	283-0220-00			CAP,FXD,CER DI:0.01UF,20%,50V	04222	SR205C103MAA
A26A1C5017	283-0220-00			CAP,FXD,CER DI:0.01UF,20%,50V	04222	SR205C103MAA
A26A1C5027	283-0220-00			CAP,FXD,CER DI:0.01UF,20%,50V	04222	SR205C103MAA
A26A1C5052	290-0804-00			CAP,FXD,ELCTLT:10UF,+50-20%,25V	80009	290-0804-00
A26A1C5056	283-0024-00			CAP,FXD,CER DI:0.1UF,+80-20%,50V	05397	C330C10YZ5U1CA
A26A1C5066	283-0024-00			CAP,FXD,CER DI:0.1UF,+80-20%,50V	05397	C330C10YZ5U1CA
A26A1C5067	283-0024-00			CAP,FXD,CER DI:0.1UF,+80-20%,50V	05397	C330C10YZ5U1CA
A26A1C5068	290-0804-00			CAP,FXD,ELCTLT:10UF,+50-20%,25V	80009	290-0804-00
A26A1C5072	290-0804-00			CAP,FXD,ELCTLT:10UF,+50-20%,25V	80009	290-0804-00
A26A1CR1065	152-0141-02			DIODE,SIG:ULTRA FAST;40V,150MA,4NS,2PF;1N4152,DO-35,T&R	80009	152-0141-02
A26A1CR2068	152-0650-00			DIODE,SIG:VVC;30V,2.3PF@C25,C3/25=5.25;BB105B,PLASTIC STRIPLINE	50101	U11-4101
A26A1CR4070	152-0322-00			DIODE,SIG:SCHTKY,;15V,410MVF AT 1MA,1.2PF;5082-2811,T&R	80009	152-0322-00
A26A1CR4077	152-0141-02			DIODE,SIG:ULTRA FAST;40V,150MA,4NS,2PF;1N4152,DO-35,T&R	80009	152-0141-02
A26A1L1020	108-0733-00			COIL,RF:FIXED,117NH	80009	108-0733-00
A26A1L1074	108-1198-00			COIL,RF:FXD,14NH NOM, 2.5 TURNS #18 WIRE, DIA .13,LENGTH .38	TK1345	108-1198-00
A26A1L3014	108-0733-00			COIL,RF:FIXED,117NH	80009	108-0733-00
A26A1L3016	108-0733-00			COIL,RF:FIXED,117NH	80009	108-0733-00
A26A1L3020	108-0733-00			COIL,RF:FIXED,117NH	80009	108-0733-00
A26A1L5059	108-1199-00			COIL,RF:FXD,28UH,11%,TD-615	80009	108-1199-00
A26A1P1028	131-0265-00			CONN,RF PLUG: SMB,PCB,MALE,RTANG,50 OHM,0.381 H X 0.150 TAIL,0.043 DIA CTR COND,0.040 SQ TAIL	80009	131-0265-00
A26A1P1039	131-0265-00			CONN,RF PLUG: SMB,PCB,MALE,RTANG,50 OHM,0.381 H X 0.150 TAIL,0.043 DIA CTR COND,0.040 SQ TAIL	80009	131-0265-00
A26A1P1060	131-0265-00			CONN,RF PLUG: SMB,PCB,MALE,RTANG,50 OHM,0.381 H X 0.150 TAIL,0.043 DIA CTR COND,0.040 SQ TAIL	80009	131-0265-00
A26A1Q1015	151-0282-00			TRANSISTOR,SIG:BIPOLAR,NPN;12V,50MA,900MHZ,AMPLIFIER;2N5179,TO-72	80009	151-0282-00
A26A1Q2049	151-0630-00			TRANSISTOR,SIG:BIPOLAR,NPN;12V,70MA,4.5GHZ,AMPLIFIER;NE02135,4 PIN CERAMIC X PKG	S0545	NE02135

Replaceable Electrical Parts
494A/494AP Service Vol.2

Component No.	Tektronix Part No.	Serial/Assembly No. Effective Dscont	Name & Description	Mfr. Code	Mfr. Part No.
A26A1Q2051	151-0301-00		TRANSISTOR, SIG: BIPOLAR, PNP; 60V, 600MA, 200MHZ, AMPLIFIER; 2N2907A, TO-18	80009	151-0301-00
A26A1Q2055	151-0301-00		TRANSISTOR, SIG: BIPOLAR, PNP; 60V, 600MA, 200MHZ, AMPLIFIER; 2N2907A, TO-18	80009	151-0301-00
A26A1Q2058	151-0752-00		TRANSISTOR, SIG: BIPOLAR, NPN; 15V, 75MA, 4.0GHZ, AMPLIFIER, PHILIPS ONLY; BFR96, SOT-37/MACRO-T	80009	151-0752-00
A26A1Q2071	151-0719-00		TRANSISTOR, SIG: BIPOLAR, PNP; 20V, 50MA, 600MHZ, AMPLIFIER; MP5H81, TO-92 BEC	80009	151-0719-00
A26A1Q2076	151-0302-00		TRANSISTOR, SIG: BIPOLAR, NPN; 40V, 800MA, 300MHZ, AMPLIFIER; 2N2222A, TO-18	80009	151-0302-00
A26A1Q4014	151-0302-00		TRANSISTOR, SIG: BIPOLAR, NPN; 40V, 800MA, 300MHZ, AMPLIFIER; 2N2222A, TO-18	80009	151-0302-00
A26A1Q4016	151-0302-00		TRANSISTOR, SIG: BIPOLAR, NPN; 40V, 800MA, 300MHZ, AMPLIFIER; 2N2222A, TO-18	80009	151-0302-00
A26A1Q5027	151-0302-00		TRANSISTOR, SIG: BIPOLAR, NPN; 40V, 800MA, 300MHZ, AMPLIFIER; 2N2222A, TO-18	80009	151-0302-00
A26A1R1012	315-0621-00		RES, FXD, FILM: 620 OHM, 5%, 0.25W	80009	315-0621-00
A26A1R1017	315-0100-00		RES, FXD, FILM: 10 OHM, 5%, 0.25W	19701	5043CX10RR00J
A26A1R1018	315-0221-00		RES, FXD, FILM: 220 OHM, 5%, 0.25W	80009	315-0221-00
A26A1R1021	315-0221-00		RES, FXD, FILM: 220 OHM, 5%, 0.25W	80009	315-0221-00
A26A1R1022	315-0101-00		RES, FXD, FILM: 100 OHM, 5%, 0.25W	80009	315-0101-00
A26A1R1045	315-0560-00		RES, FXD, FILM: 56 OHM, 5%, 0.25W	80009	315-0560-00
A26A1R1047	315-0562-00		RES, FXD, FILM: 5.6K OHM, 5%, 0.25W	80009	315-0562-00
A26A1R1049	315-0202-00		RES, FXD, FILM: 2K OHM, 5%, 0.25W	80009	315-0202-00
A26A1R1051	315-0201-00		RES, FXD, FILM: 200 OHM, 5%, 0.25W	80009	315-0201-00
A26A1R1053	315-0562-00		RES, FXD, FILM: 5.6K OHM, 5%, 0.25W	80009	315-0562-00
A26A1R1054	315-0132-00		RES, FXD, FILM: 1.3K OHM, 5%, 0.25W	80009	315-0132-00
A26A1R1056	315-0680-00		RES, FXD, FILM: 68 OHM, 5%, 0.25W	80009	315-0680-00
A26A1R1057	315-0300-00		RES, FXD, FILM: 30 OHM, 5%, 0.25W	80009	315-0300-00
A26A1R1066	317-0101-00		RES, FXD, CMPSN: 100 OHM, 5%, 0.125W	80009	317-0101-00
A26A1R1068	317-0101-00		RES, FXD, CMPSN: 100 OHM, 5%, 0.125W	80009	317-0101-00
A26A1R2013	315-0152-00		RES, FXD, FILM: 1.5K OHM, 5%, 0.25W	80009	315-0152-00
A26A1R2016	317-0512-00		RES, FXD, CMPSN: 5.1K OHM, 5%, 0.125W	80009	317-0512-00
A26A1R2017	317-0180-00		RES, FXD, CMPSN: 18 OHM, 5%, 0.125W	80009	317-0180-00
A26A1R2022	317-0180-00		RES, FXD, CMPSN: 18 OHM, 5%, 0.125W	80009	317-0180-00
A26A1R2023	317-0180-00		RES, FXD, CMPSN: 18 OHM, 5%, 0.125W	80009	317-0180-00
A26A1R2024	315-0510-00		RES, FXD, FILM: 51 OHM, 5%, 0.25W	80009	315-0510-00
A26A1R2025	315-0104-00		RES, FXD, FILM: 100K OHM, 5%, 0.25W	80009	315-0104-00
A26A1R2031	321-0184-00		RES, FXD, FILM: 806 OHM, 1%, 0.125W, TC=TO	80009	321-0184-00
A26A1R2032	321-0184-00		RES, FXD, FILM: 806 OHM, 1%, 0.125W, TC=TO	80009	321-0184-00
A26A1R2044	315-0101-00		RES, FXD, FILM: 100 OHM, 5%, 0.25W	80009	315-0101-00
A26A1R2047	317-0332-00		RES, FXD, CMPSN: 3.3K OHM, 5%, 0.125W	80009	317-0332-00
A26A1R2049	317-0100-00		RES, FXD, CMPSN: 10 OHM, 5%, 0.125W	80009	317-0100-00
A26A1R2050	317-0201-00		RES, FXD, CMPSN: 200 OHM, 5%, 0.125W	80009	317-0201-00
A26A1R2051	317-0101-00		RES, FXD, CMPSN: 100 OHM, 5%, 0.125W	80009	317-0101-00
A26A1R2056	317-0332-00		RES, FXD, CMPSN: 3.3K OHM, 5%, 0.125W	80009	317-0332-00
A26A1R2057	317-0047-00		RES, FXD, CMPSN: 4.7 OHM, 5%, 0.125W	80009	317-0047-00
A26A1R2058	317-0511-00		RES, FXD, CMPSN: 510 OHM, 5%, 0.125W	80009	317-0511-00
A26A1R2060	317-0101-00		RES, FXD, CMPSN: 100 OHM, 5%, 0.125W	80009	317-0101-00
A26A1R2065	317-0330-00		RES, FXD, CMPSN: 33 OHM, 5%, 0.125W	80009	317-0330-00
A26A1R2068	317-0332-00		RES, FXD, CMPSN: 3.3K OHM, 5%, 0.125W	80009	317-0332-00
A26A1R2071	317-0102-00		RES, FXD, CMPSN: 1K OHM, 5%, 0.125W	80009	317-0102-00
A26A1R2072	317-0911-00		RES, FXD, CMPSN: 910 OHM, 5%, 0.125W	80009	317-0911-00
A26A1R2074	317-0332-00		RES, FXD, CMPSN: 3.3K OHM, 5%, 0.125W	80009	317-0332-00
A26A1R2075	317-0472-00		RES, FXD, CMPSN: 4.7K OHM, 5%, 0.125W	80009	317-0472-00
A26A1R2076	317-0103-00		RES, FXD, CMPSN: 10K OHM, 5%, 0.125W	80009	317-0103-00
A26A1R3022	315-0471-00		RES, FXD, FILM: 470 OHM, 5%, 0.25W	80009	315-0471-00
A26A1R3037	315-0100-00		RES, FXD, FILM: 10 OHM, 5%, 0.25W	19701	5043CX10RR00J

Replaceable Electrical Parts
494A/494AP Service Vol.2

Component No.	Tektronix	Serial/Assembly No.		Name & Description	Mfr.	Mfr. Part No.
	Part No.	Effective	Dscont		Code	
A26A1R3038	315-0154-00			RES,FXD,FILM:150K OHM,5%,0.25W	80009	315-0154-00
A26A1R3041	321-0298-00			RES,FXD,FILM:12.4K OHM,1%,0.125W,TC=TO	07716	CEAD12401F
A26A1R3042	321-0298-00			RES,FXD,FILM:12.4K OHM,1%,0.125W,TC=TO	07716	CEAD12401F
A26A1R3043	321-0315-00			RES,FXD,FILM:18.7K OHM,1%,0.125W,TC=TO	80009	321-0315-00
A26A1R3044	321-0315-00			RES,FXD,FILM:18.7K OHM,1%,0.125W,TC=TO	80009	321-0315-00
A26A1R3045	321-0298-00			RES,FXD,FILM:12.4K OHM,1%,0.125W,TC=TO	07716	CEAD12401F
A26A1R3046	321-0298-00			RES,FXD,FILM:12.4K OHM,1%,0.125W,TC=TO	07716	CEAD12401F
A26A1R3050	315-0510-00			RES,FXD,FILM:51 OHM,5%,0.25W	80009	315-0510-00
A26A1R3055	317-0470-00			RES,FXD,CMPSN:47 OHM,5%,0.125W	80009	317-0470-00
A26A1R3057	317-0470-00			RES,FXD,CMPSN:47 OHM,5%,0.125W	80009	317-0470-00
A26A1R3058	317-0470-00			RES,FXD,CMPSN:47 OHM,5%,0.125W	80009	317-0470-00
A26A1R3065	317-0331-00			RES,FXD,CMPSN:330 OHM,5%,0.125W	80009	317-0331-00
A26A1R3070	315-0202-00			RES,FXD,FILM:2K OHM,5%,0.25W	80009	315-0202-00
A26A1R3071	317-0101-00			RES,FXD,CMPSN:100 OHM,5%,0.125W	80009	317-0101-00
A26A1R3076	317-0472-00			RES,FXD,CMPSN:4.7K OHM,5%,0.125W	80009	317-0472-00
A26A1R4015	315-0470-00			RES,FXD,FILM:47 OHM,5%,0.25W	80009	315-0470-00
A26A1R4016	315-0132-00			RES,FXD,FILM:1.3K OHM,5%,0.25W	80009	315-0132-00
A26A1R4023	315-0271-00			RES,FXD,FILM:270 OHM,5%,0.25W	80009	315-0271-00
A26A1R4024	315-0103-00			RES,FXD,FILM:10K OHM,5%,0.25W	80009	315-0103-00
A26A1R4027	315-0103-00			RES,FXD,FILM:10K OHM,5%,0.25W	80009	315-0103-00
A26A1R4038	315-0154-00			RES,FXD,FILM:150K OHM,5%,0.25W	80009	315-0154-00
A26A1R4040	315-0154-00			RES,FXD,FILM:150K OHM,5%,0.25W	80009	315-0154-00
A26A1R4047	315-0154-00			RES,FXD,FILM:150K OHM,5%,0.25W	80009	315-0154-00
A26A1R4049	315-0154-00			RES,FXD,FILM:150K OHM,5%,0.25W	80009	315-0154-00
A26A1R4052	321-0756-00			RES,FXD,FILM:50K OHM,1%,0.125W,TC=TO	01121	
A26A1R4073	315-0332-00			RES,FXD,FILM:3.3K OHM,5%,0.25W	80009	315-0332-00
A26A1R5016	317-0160-00			RES,FXD,CMPSN:16 OHM,5%,0.125W	80009	317-0160-00
A26A1R5017	317-0160-00			RES,FXD,CMPSN:16 OHM,5%,0.125W	80009	317-0160-00
A26A1R5020	315-0510-00			RES,FXD,FILM:51 OHM,5%,0.25W	80009	315-0510-00
A26A1R5021	315-0104-00			RES,FXD,FILM:100K OHM,5%,0.25W	80009	315-0104-00
A26A1R5023	315-0103-00			RES,FXD,FILM:10K OHM,5%,0.25W	80009	315-0103-00
A26A1R5024	315-0103-00			RES,FXD,FILM:10K OHM,5%,0.25W	80009	315-0103-00
A26A1R5025	315-0223-00			RES,FXD,FILM:22K OHM,5%,0.25W	80009	315-0223-00
A26A1R5038	315-0154-00			RES,FXD,FILM:150K OHM,5%,0.25W	80009	315-0154-00
A26A1R5039	315-0154-00			RES,FXD,FILM:150K OHM,5%,0.25W	80009	315-0154-00
A26A1R5072	307-0108-00			RES,FXD,CMPSN:6.8 OHM,5%,0.25W	80009	307-0108-00
A26A1T4014	120-1509-00			TRANSFORMER,RF:TOROID,257NH TD-419	80009	120-1509-00
A26A1T5022	120-1510-00			TRANSFORMER,RF:TOROID,35.5NH,30% TD-420	80009	120-1510-00
A26A1U2017	156-1248-00			IC,DIGITAL:ECL,PRESALER;DIVIDE BY 100;SP86 29,DIP08.3	80009	156-1248-00
A26A1U2040	156-1272-03			IC,LINEAR:BIPOLAR,OP-AMP;DUAL,HIGH OUTPUT D RIVE,MAX NOISE SPECS;NE5532AN,DIP08.3	80009	156-1272-03
A26A1U3051	156-1862-00			IC,DIGITAL:BIPOLAR,PRESALER;DIVIDE BY 32/3 3,TWO MODULUS,225MHZ;MC12015P,DIP08.3	04713	MC12015(PD/LD)
A26A1U3059	156-0469-00			IC,DIGITAL:LSTTL,DEMUX/DECODER;3-TO-8 DECOD ER;74LS138,DIP16.3,TUBE	80009	156-0469-00
A26A1U4021	156-1709-00			IC,LINEAR:BIPOLAR,AMPLIFIER;IF AMP,45MHZ,W/ AGC;MC1350P,DIP08.3	80009	156-1709-00
A26A1U4041	156-1742-00			IC,DIGITAL:CMOS,FREQ SYNTH;W/PLL,4 BIT DATA BUS INPUT;MC145146P1,DIP20.3	04713	MC145146L
A26A1U4066	156-0058-00			IC,DIGITAL:TTL,GATE;HEX INV;7404,DIP14.3,TU BE	01295	SN7404N
A26A1U4074	156-0388-00			IC,DIGITAL:LSTTL,FLIP FLOP;DUAL D W/SET & C LR;74LS74,DIP14.3,TUBE	80009	156-0388-00
A26A1U5015	156-1248-00			IC,DIGITAL:ECL,PRESALER;DIVIDE BY 100;SP86 29,DIP08.3	80009	156-1248-00
A26A1U5073	156-0277-00			IC,LINEAR:BIPOLAR,VOLTAGE REGULATOR;POSITIV E,5.0V,1.0A,4%;MC7805CT,TO-220	80009	156-0277-00

Replaceable Electrical Parts
494A/494AP Service Vol.2

Component No.	Tektronix		Serial/Assembly No.		Name & Description	Mfr. Code	Mfr. Part No.
	Part No.	Effective	Dscnt				
A28	670-7920-01				CIRCUIT BD ASSY:MAIN MOTHER	80009	670-7920-01
A30	621-0023-00	B010100	B010249		POWER SUPPLY:	80009	621-0023-00
A30	621-0023-01	B010250			POWER SUPPLY: (494A ONLY)	80009	621-0023-01
A30	621-0024-00	B010100	B010249		POWER SUPPLY:	80009	621-0024-00
A30	621-0024-01	B010250			POWER SUPPLY: (494AP ONLY)	80009	621-0024-01
A30	621-0030-00	B010100	B010249		POWER SUPPLY:	80009	621-0030-00
A30	621-0030-01	B010250			POWER SUPPLY: (494A OPTION 42 ONLY)	80009	621-0030-01
A30	621-0031-00	B010100	B010249		POWER SUPPLY:	80009	621-0031-00
A30	621-0031-01	B010250			POWER SUPPLY: (494AP OPTION 42 ONLY)	80009	621-0031-01
A30B100	119-0830-01				FAN,TUBEAXIAL:12VDC,2.4W,5250 RPM,31 CFM	TK0146	MODEL 69.11.53
A30B200	119-1719-01				FAN,TUBEAXIAL:12VDC,4.3W,2750 RPM, 106 CFM, 120 X 120 MM,40 MM THICK (OPTION 42 ONLY)	TK1409	ORDER BY DESCR
A30C200	290-0845-00				CAP,FXD,ELCTLT:330UF,+50-10%,25V (OPTION 42 ONLY)	54473	ECE-A25V330L
A30CRI	152-0141-02				DIODE,SIG:,ULTRA FAST;40V,150MA,4NS,2PF;1N4 152,DO-35,T&R (OPTION 42 ONLY)	80009	152-0141-02
A30F301	159-0017-00				FUSE,CARTRIDGE:3AG,4A,250V,FAST BLOW	71400	AGC-4
A30FL301	119-1306-00				FILTER,RFI:6A,250V,50-400HZ	24165	6JX5431A
A30FL302	119-1390-00				FILTER,RFI:POT CORE SET(2),1- 120-1365-00,1 15UH 10%,3A,.059 OHM, 1- 120-1364-00,11MH	80009	119-1390-00
A30R1	315-0471-00				RES,FXD,FILM:470 OHM,5%,0.25W (OPTION 42 ONLY)	80009	315-0471-00
A30R301	301-0514-01				RES,FXD,CMPSN:510K OHM,5%,0.5W	01121	EB5145
A30S300	260-1931-00				SWITCH,SENS:SPST NO,10(4)A,250V	TK0935	1005.0925
A30S301	260-1931-00				SWITCH,SENS:SPST NO,10(4)A,250V	TK0935	1005.0925
A30S302	260-1967-00				SWITCH,SLIDE:DPDT 5A/250V 10A/125V MKD	TK0935	4021.0512
A30U301	119-1168-00				CAPACITOR-RES:0.1UF,20% & 22 OHM,10%,250VAC	14752	RG1782-1
A30W192	175-9621-00				CABLE ASSY,RF:50 OHM COAX,23.5 L (OPTION 42 ONLY)	80009	175-9621-00
A30W560	174-0447-00				CA ASSY,SP,ELEC:26,26AWG,22.0 L,RIBBON	80009	174-0447-00
A30W620	175-3619-01				CABLE ASSY,RF:50 OHM COAX,16.0 L,SEMI-RGD	80009	175-3619-01
A30W1011	175-2480-00				CA ASSY,SP,ELEC:2,26 AWG,11.0 L,RIBBON (494AP ONLY)	TK1375	175-2480-00
A30W1021	175-9618-00				CABLE ASSY,RF:50 OHM COAX,11.0 L,9-5 (OPTION 42 ONLY)	80009	175-9618-00
A30W3045	175-3557-00				CA ASSY,SP,ELEC:5,26 AWG,18.0 L,RIBBON	TK1375	175-3557-00
A30A1	670-8036-01	B010100	B010249		CIRCUIT BD ASSY:PWR SPLY	80009	670-8036-01
A30A1	670-8036-04	B010250			CIRCUIT BD ASSY:PWR SPLY	80009	670-8036-04
A30A1C1055	290-0758-00				CAP,FXD,ELCTLT:2.2UF,+50-10%,200V	80009	290-0758-00
A30A1C1063	285-1089-00				CAP,FXD,PLASTIC:0.04UF,5%,900V	50558	PA6-0787J
A30A1C1095	285-1196-00				CAP,FXD,PPR DI:0.01UF,20%,250V	80009	285-1196-00
A30A1C2024	283-0330-00				CAP,FXD,CER DI:100PF,5%,50V	80009	283-0330-00
A30A1C2030	283-0238-00				CAP,FXD,CER DI:0.01UF,10%,50V	80009	283-0238-00
A30A1C2032	283-0330-00				CAP,FXD,CER DI:100PF,5%,50V	80009	283-0330-00
A30A1C2033	283-0486-00				CAP,FXD,CER DI:1.0UF,10%,50V	04222	SR305C105KAA
A30A1C2034	283-0330-00				CAP,FXD,CER DI:100PF,5%,50V	80009	283-0330-00
A30A1C2035	283-0156-00				CAP,FXD,CER DI:1000PF,+80-20%,200V	04222	SR152E102ZAA
A30A1C2041	290-0758-00				CAP,FXD,ELCTLT:2.2UF,+50-10%,200V	80009	290-0758-00
A30A1C2043	290-1034-00				CAP,FXD,ELCTLT:330UF,25V,20%	TK1424	CEUFM1E331
A30A1C2045	290-0758-00				CAP,FXD,ELCTLT:2.2UF,+50-10%,200V	80009	290-0758-00
A30A1C2053	290-0758-00				CAP,FXD,ELCTLT:2.2UF,+50-10%,200V	80009	290-0758-00
A30A1C2057	290-0758-00				CAP,FXD,ELCTLT:2.2UF,+50-10%,200V	80009	290-0758-00
A30A1C2096	285-1196-00				CAP,FXD,PPR DI:0.01UF,20%,250V	80009	285-1196-00
A30A1C3031	283-0330-00				CAP,FXD,CER DI:100PF,5%,50V	80009	283-0330-00

Replaceable Electrical Parts
494A/494AP Service Vol.2

Component No.	Tektronix		Serial/Assembly No. Effective Dscont	Name & Description	Mfr.	Mfr. Part No.
	Part No.				Code	
A30A1C3033	283-0486-00			CAP, FXD, CER DI: 1.0UF, 10%, 50V	04222	SR305C105KAA
A30A1C3034	283-0330-00			CAP, FXD, CER DI: 100PF, 5%, 50V	80009	283-0330-00
A30A1C3035	283-0330-00			CAP, FXD, CER DI: 100PF, 5%, 50V	80009	283-0330-00
A30A1C3036	283-0486-00			CAP, FXD, CER DI: 1.0UF, 10%, 50V	04222	SR305C105KAA
A30A1C3037	283-0486-00			CAP, FXD, CER DI: 1.0UF, 10%, 50V	04222	SR305C105KAA
A30A1C3041	290-0770-00			CAP, FXD, ELCTLT: 100UF, +50-20%, 25VDC	54473	ECE-A25V100L
A30A1C3051	290-0771-00			CAP, FXD, ELCTLT: 220UF, +50-10%, 10VDC	24165	513D227M016CC4
A30A1C3057	290-0852-00			CAP, FXD, ELCTLT: 1UF, +75-10%, 350V	TK0900	
A30A1C3064	285-1196-00			CAP, FXD, PPR DI: 0.01UF, 20%, 250V	80009	285-1196-00
A30A1C3071	285-0981-00			CAP, FXD, PLASTIC: 2UF, 10%, 400V	80009	285-0981-00
A30A1C3074	285-1040-00			CAP, FXD, PLASTIC: 1200PF, 10%, 4000V	24165	430P522
A30A1C4012	290-0745-00			CAP, FXD, ELCTLT: 22UF, +50-20%, 25WVDC	80009	290-0745-00
A30A1C4014	283-0111-00			CAP, FXD, CER DI: 0.1UF, 20%, 50V	80009	283-0111-00
A30A1C4015	283-0211-00			CAP, FXD, CER DI: 0.1UF, 10%, 200V	80009	283-0211-00
A30A1C4016	283-0111-00			CAP, FXD, CER DI: 0.1UF, 20%, 50V	80009	283-0111-00
A30A1C4022	290-0745-00			CAP, FXD, ELCTLT: 22UF, +50-20%, 25WVDC	80009	290-0745-00
A30A1C4023	290-0942-00			CAP, FXD, ELCTLT: 100UF, +100-10%, 25V	24165	672D107H025CG2C
A30A1C4024	283-0111-00			CAP, FXD, CER DI: 0.1UF, 20%, 50V	80009	283-0111-00
A30A1C4032	283-0111-00			CAP, FXD, CER DI: 0.1UF, 20%, 50V	80009	283-0111-00
A30A1C4033	290-0770-00			CAP, FXD, ELCTLT: 100UF, +50-20%, 25VDC	54473	ECE-A25V100L
A30A1C4035	290-0745-00			CAP, FXD, ELCTLT: 22UF, +50-20%, 25WVDC	80009	290-0745-00
A30A1C4036	283-0111-00			CAP, FXD, CER DI: 0.1UF, 20%, 50V	80009	283-0111-00
A30A1C4044	290-1034-00			CAP, FXD, ELCTLT: 330UF, 25V, 20%	TK1424	CEUFM1E331
A30A1C4046	290-1034-00			CAP, FXD, ELCTLT: 330UF, 25V, 20%	TK1424	CEUFM1E331
A30A1C4051	290-1034-00			CAP, FXD, ELCTLT: 330UF, 25V, 20%	TK1424	CEUFM1E331
A30A1C4055	290-1034-00			CAP, FXD, ELCTLT: 330UF, 25V, 20%	TK1424	CEUFM1E331
A30A1C4082	283-0263-00			CAP, FXD, CER DI: 2200PF, 20%, 3000V	80009	283-0263-00
A30A1C5010	283-0008-00			CAP, FXD, CER DI: 0.1UF, 20%, 500V	04222	SR507C104MAA
A30A1C5012	290-0758-00			CAP, FXD, ELCTLT: 2.2UF, +50-10%, 200V	80009	290-0758-00
A30A1C5017	283-0486-00			CAP, FXD, CER DI: 1.0UF, 10%, 50V	04222	SR305C105KAA
A30A1C5018	290-1034-00			CAP, FXD, ELCTLT: 330UF, 25V, 20%	TK1424	CEUFM1E331
A30A1C5021	283-0111-00			CAP, FXD, CER DI: 0.1UF, 20%, 50V	80009	283-0111-00
A30A1C5022	290-0745-00			CAP, FXD, ELCTLT: 22UF, +50-20%, 25WVDC	80009	290-0745-00
A30A1C5038	285-0699-00			CAP, FXD, PLASTIC: 0.0047UF, 10%, 100V	80009	285-0699-00
A30A1C5051	290-1034-00			CAP, FXD, ELCTLT: 330UF, 25V, 20%	TK1424	CEUFM1E331
A30A1C5054	290-1034-00			CAP, FXD, ELCTLT: 330UF, 25V, 20%	TK1424	CEUFM1E331
A30A1C5071	283-0111-00			CAP, FXD, CER DI: 0.1UF, 20%, 50V	80009	283-0111-00
A30A1C5072	290-0804-00			CAP, FXD, ELCTLT: 10UF, +50-20%, 25V	80009	290-0804-00
A30A1C5082	283-0263-00			CAP, FXD, CER DI: 2200PF, 20%, 3000V	80009	283-0263-00
A30A1C5084	290-0114-00			CAP, FXD, ELCTLT: 47UF, 20%, 6V	05397	T110B476M006AS
A30A1C5085	290-0114-00			CAP, FXD, ELCTLT: 47UF, 20%, 6V	05397	T110B476M006AS
A30A1C5113	283-0211-00			CAP, FXD, CER DI: 0.1UF, 10%, 200V	80009	283-0211-00
A30A1C6010	283-0111-00			CAP, FXD, CER DI: 0.1UF, 20%, 50V	80009	283-0111-00
A30A1C6019	283-0486-00			CAP, FXD, CER DI: 1.0UF, 10%, 50V	04222	SR305C105KAA
A30A1C6025	290-0523-00			CAP, FXD, ELCTLT: 2.2UF, 20%, 20V	80009	290-0523-00
A30A1C6033	283-0486-00			CAP, FXD, CER DI: 1.0UF, 10%, 50V	04222	SR305C105KAA
A30A1C6039	283-0204-00			CAP, FXD, CER DI: 0.01UF, 20%, 50V	51406	RPE110Z5U103M50V
A30A1C6048	285-1301-00			CAP, FXD, PLASTIC: 0.47UF, 10%, 63V	80009	285-1301-00
A30A1C6053	285-1301-00			CAP, FXD, PLASTIC: 0.47UF, 10%, 63V	80009	285-1301-00
A30A1C6055	283-0620-00			CAP, FXD, MICA DI: 470PF, 1%, 500V	80009	283-0620-00
A30A1C6058	283-0620-00			CAP, FXD, MICA DI: 470PF, 1%, 500V	80009	283-0620-00
A30A1C6059	283-0111-00			CAP, FXD, CER DI: 0.1UF, 20%, 50V	80009	283-0111-00
A30A1C6062	285-1301-00			CAP, FXD, PLASTIC: 0.47UF, 10%, 63V	80009	285-1301-00
A30A1C6068	285-1301-00			CAP, FXD, PLASTIC: 0.47UF, 10%, 63V	80009	285-1301-00
A30A1C6069	283-0204-00			CAP, FXD, CER DI: 0.01UF, 20%, 50V	51406	RPE110Z5U103M50V
A30A1C6071	283-0067-00			CAP, FXD, CER DI: 0.001UF, 10%, 200V	51406	
A30A1C6072	283-0067-00			CAP, FXD, CER DI: 0.001UF, 10%, 200V	51406	
A30A1C6101	290-0829-00			CAP, FXD, ELCTLT: 750UF, +100-10%, 200V	24165	68D11009

Replaceable Electrical Parts
494A/494AP Service Vol. 2

Component No.	Tektronix Part No.	Serial/Assembly No. Effective Dscnt	Name & Description	Mfr. Code	Mfr. Part No.
A30A1C6111	290-0829-00		CAP, FXD, ELCTLT: 750UF, +100-10%, 20CV	24165	68D11009
A30A1CR1022	152-0400-00		DIODE, RECT: ,FAST RCVRY; 400V, 1A, 200NS; 1N4936 ,DO-41, T&R	80009	152-0400-00
A30A1CR1034	152-0400-00		DIODE, RECT: ,FAST RCVRY; 400V, 1A, 200NS; 1N4936 ,DO-41, T&R	80009	152-0400-00
A30A1CR1042	152-0400-00		DIODE, RECT: ,FAST RCVRY; 400V, 1A, 200NS; 1N4936 ,DO-41, T&R	80009	152-0400-00
A30A1CR2027	152-0141-02		DIODE, SIG: ,ULTRA FAST; 40V, 150MA, 4NS, 2PF; 1N4 152, DO-35, T&R	80009	152-0141-02
A30A1CR2028	152-0141-02		DIODE, SIG: ,ULTRA FAST; 40V, 150MA, 4NS, 2PF; 1N4 152, DO-35, T&R	80009	152-0141-02
A30A1CR2035	152-0141-02		DIODE, SIG: ,ULTRA FAST; 40V, 150MA, 4NS, 2PF; 1N4 152, DO-35, T&R	80009	152-0141-02
A30A1CR2061	152-0661-00		DIODE, RECT: ,FAST RCVRY; 600V, 3A, 200NS; T&R	80009	152-0661-00
A30A1CR2063	152-0661-00		DIODE, RECT: ,FAST RCVRY; 600V, 3A, 200NS; T&R	80009	152-0661-00
A30A1CR2065	152-0661-00		DIODE, RECT: ,FAST RCVRY; 600V, 3A, 200NS; T&R	80009	152-0661-00
A30A1CR2079	152-0661-00		DIODE, RECT: ,FAST RCVRY; 600V, 3A, 200NS; T&R	80009	152-0661-00
A30A1CR3027	152-0141-02		DIODE, SIG: ,ULTRA FAST; 40V, 150MA, 4NS, 2PF; 1N4 152, DO-35, T&R	80009	152-0141-02
A30A1CR3028	152-0141-02		DIODE, SIG: ,ULTRA FAST; 40V, 150MA, 4NS, 2PF; 1N4 152, DO-35, T&R	80009	152-0141-02
A30A1CR3035	152-0141-02		DIODE, SIG: ,ULTRA FAST; 40V, 150MA, 4NS, 2PF; 1N4 152, DO-35, T&R	80009	152-0141-02
A30A1CR3052	152-0400-00		DIODE, RECT: ,FAST RCVRY; 400V, 1A, 200NS; 1N4936 ,DO-41, T&R	80009	152-0400-00
A30A1CR3053	152-0400-00		DIODE, RECT: ,FAST RCVRY; 400V, 1A, 200NS; 1N4936 ,DO-41, T&R	80009	152-0400-00
A30A1CR3054	152-0400-00		DIODE, RECT: ,FAST RCVRY; 400V, 1A, 200NS; 1N4936 ,DO-41, T&R	80009	152-0400-00
A30A1CR3055	152-0400-00		DIODE, RECT: ,FAST RCVRY; 400V, 1A, 200NS; 1N4936 ,DO-41, T&R	80009	152-0400-00
A30A1CR3056	152-0400-00		DIODE, RECT: ,FAST RCVRY; 400V, 1A, 200NS; 1N4936 ,DO-41, T&R	80009	152-0400-00
A30A1CR3096	152-0661-00		DIODE, RECT: ,FAST RCVRY; 600V, 3A, 200NS; T&R	80009	152-0661-00
A30A1CR3098	152-0661-00		DIODE, RECT: ,FAST RCVRY; 600V, 3A, 200NS; T&R	80009	152-0661-00
A30A1CR4021	152-0066-00		DIODE, RECT: ,; 400V, 1A, IFSM = 30A; GP10G, DO-41 ,T&R, SAFETY CONTROLLED	05828	GP10G-020
A30A1CR4034	152-0066-00		DIODE, RECT: ,; 400V, 1A, IFSM = 30A; GP10G, DO-41 ,T&R, SAFETY CONTROLLED	05828	GP10G-020
A30A1CR4037	152-0066-00		DIODE, RECT: ,; 400V, 1A, IFSM = 30A; GP10G, DO-41 ,T&R, SAFETY CONTROLLED	05828	GP10G-020
A30A1CR4053	152-0640-00		SEMICONDU DVC, DI: RECT, SI, 35V, 30A, DO-4	01281	SD-4101
A30A1CR4057	152-0640-00		SEMICONDU DVC, DI: RECT, SI, 35V, 30A, DO-4	01281	SD-4101
A30A1CR4061	152-0720-00		DIODE, RECT: ,ULTRA FAST; 100V, 8A, 25NS, 100A IF SM; BYW29-100, TO-220	80009	152-0720-00
A30A1CR4062	152-0720-00		DIODE, RECT: ,ULTRA FAST; 100V, 8A, 25NS, 100A IF SM; BYW29-100, TO-220	80009	152-0720-00
A30A1CR4063	152-0720-00		DIODE, RECT: ,ULTRA FAST; 100V, 8A, 25NS, 100A IF SM; BYW29-100, TO-220	80009	152-0720-00
A30A1CR4065	152-0720-00		DIODE, RECT: ,ULTRA FAST; 100V, 8A, 25NS, 100A IF SM; BYW29-100, TO-220	80009	152-0720-00
A30A1CR4094	152-0661-00		DIODE, RECT: ,FAST RCVRY; 600V, 3A, 200NS; T&R	80009	152-0661-00
A30A1CR4095	152-0661-00		DIODE, RECT: ,FAST RCVRY; 600V, 3A, 200NS; T&R	80009	152-0661-00
A30A1CR5031	152-0141-02		DIODE, SIG: ,ULTRA FAST; 40V, 150MA, 4NS, 2PF; 1N4 152, DO-35, T&R	80009	152-0141-02
A30A1CR5052	152-0721-00		DIODE, RECT: ,ULTRA FAST; 100V, 12A, 30NS; BYW30-100U, DO-4	12969	UTG5206
A30A1CR5055	152-0742-00		SEMICONDU DVC, DI: RECT, SI, 12A, 100V, DO-4	80009	152-0742-00

Replaceable Electrical Parts
494A/494AP Service Vol.2

Component No.	Tektronix Part No.	Serial/Assembly No.		Name & Description	Mfr. Code	Mfr. Part No.
		Effective	Dscont			
A30A1CR5062	152-0721-00			DIODE,RECT: ,ULTRA FAST;100V,12A,30NS;BYW30-100U,DO-4	12969	UTG5206
A30A1CR5065	152-0742-00			SEMICON DVC,DI:RECT,SI,12A,100V,DO-4	80009	152-0742-00
A30A1CR6014	152-0141-02			DIODE,SIG: ,ULTRA FAST;40V,150MA,4NS,2PF;1N4152,DO-35,T&R	80009	152-0141-02
A30A1CR6015	152-0141-02			DIODE,SIG: ,ULTRA FAST;40V,150MA,4NS,2PF;1N4152,DO-35,T&R	80009	152-0141-02
A30A1CR6016	152-0066-00			DIODE,RECT: ,400V,1A,IFSM = 30A;GP10G,DO-41,T&R,SAFETY CONTROLLED	05828	GP10G-020
A30A1CR6018	152-0141-02			DIODE,SIG: ,ULTRA FAST;40V,150MA,4NS,2PF;1N4152,DO-35,T&R	80009	152-0141-02
A30A1CR6047	152-0141-02			DIODE,SIG: ,ULTRA FAST;40V,150MA,4NS,2PF;1N4152,DO-35,T&R	80009	152-0141-02
A30A1CR6049	152-0141-02			DIODE,SIG: ,ULTRA FAST;40V,150MA,4NS,2PF;1N4152,DO-35,T&R	80009	152-0141-02
A30A1CR6052	152-0141-02			DIODE,SIG: ,ULTRA FAST;40V,150MA,4NS,2PF;1N4152,DO-35,T&R	80009	152-0141-02
A30A1CR6053	152-0141-02			DIODE,SIG: ,ULTRA FAST;40V,150MA,4NS,2PF;1N4152,DO-35,T&R	80009	152-0141-02
A30A1CR6055	152-0141-02			DIODE,SIG: ,ULTRA FAST;40V,150MA,4NS,2PF;1N4152,DO-35,T&R	80009	152-0141-02
A30A1CR6061	152-0141-02			DIODE,SIG: ,ULTRA FAST;40V,150MA,4NS,2PF;1N4152,DO-35,T&R	80009	152-0141-02
A30A1CR6071	152-0400-00			DIODE,RECT: ,FAST RCVR;400V,1A,200NS;1N4936,DO-41,T&R	80009	152-0400-00
A30A1CR6072	152-0141-02			DIODE,SIG: ,ULTRA FAST;40V,150MA,4NS,2PF;1N4152,DO-35,T&R	80009	152-0141-02
A30A1CR6073	152-0400-00			DIODE,RECT: ,FAST RCVR;400V,1A,200NS;1N4936,DO-41,T&R	80009	152-0400-00
A30A1CR6074	152-0141-02			DIODE,SIG: ,ULTRA FAST;40V,150MA,4NS,2PF;1N4152,DO-35,T&R	80009	152-0141-02
A30A1DS5112	150-0035-00			LAMP,GLOW:90V MAX,0.3MA,AID-T,WIRE LD	71744	A1B-120
A30A1E1094	119-0181-00			ARSR,ELEC SURGE:230,GAS FILLED,+/-15%	25088	B1-A230T
A30A1E2095	119-0181-00			ARSR,ELEC SURGE:230,GAS FILLED,+/-15%	25088	B1-A230T
A30A1F1013	159-0025-00			FUSE,CARTRIDGE:3AG,0.5A,250V,0.25SEC	71400	AGC-CW-1/2
A30A1F1017	159-0021-00			FUSE,CARTRIDGE:3AG,2A,250V,FAST BLOW	75915	312 002
A30A1F1033	159-0213-00			FUSE,CARTRIDGE:0.062A,250V,FAST BLOW	71400	1/16A
A30A1F1035	159-0028-00			FUSE,CARTRIDGE:0.25A,250V,FAST BLOW	71400	AGC-1/4
A30A1F2013	159-0021-00			FUSE,CARTRIDGE:3AG,2A,250V,FAST BLOW	75915	312 002
A30A1F3038	159-0128-00	B010100	B020623	FUSE,CANISTER:2A,125V,5 SEC,RADIAL LEAD	75915	273002
A30A1F3038	159-0208-00	B020624		FUSE,WIRE LEAD:2A,125V,5 SEC	75915	255002
A30A1J5041	131-2324-00			CONN,EDGECARD: :	31781	307-040-526-300
A30A1L1051	108-0960-00			COIL,RF:FIXED,3.9MH	80009	108-0960-00
A30A1L1081	108-1052-00			COIL,RF:FIXED,580UH	80009	108-1052-00
A30A1L2048	108-0959-00			COIL,RF:FIXED,150UH	TK1345	108-0959-00
A30A1L3012	108-0795-00			COIL,RF:FIXED,2MH	TK1345	108-0795-00
A30A1L3043	108-0959-00			COIL,RF:FIXED,150UH	TK1345	108-0959-00
A30A1L3047	108-0958-00			COIL,RF:FIXED,50UH	80009	108-0958-00
A30A1L3088	108-0961-00			COIL,RF:FIXED,140NH	80009	108-0961-00
A30A1L4042	108-0958-00			COIL,RF:FIXED,50UH	80009	108-0958-00
A30A1Q2021	151-0625-00			TRANSISTOR,PNR: BIPOLAR,PNP;80V,10A,40MHZ,AMPLIFIER;D45H11,TO-220	80009	151-0625-00
A30A1Q2023	151-0710-00			TRANSISTOR,SIG: BIPOLAR,NPN;40V,1.0A,50MHZ,AMPLIFIER;2N6715/MP5W01A,TO-237/TO-226AE	80009	151-0710-00
A30A1Q2024	151-0625-00			TRANSISTOR,PNR: BIPOLAR,PNP;80V,10A,40MHZ,AMPLIFIER;D45H11,TO-220	80009	151-0625-00
A30A1Q2031	151-0302-00			TRANSISTOR,SIG: BIPOLAR,NPN;40V,800MA,300MHZ,AMPLIFIER;2N2222A,TO-18	80009	151-0302-00

Replaceable Electrical Parts
494A/494AP Service Vol. 2

Component No.	Tektronix Part No.	Serial/Assembly No.		Name & Description	Mfr. Code	Mfr. Part No.
		Effective	Discont			
A30A1Q2061	151-0703-00			TRANSISTOR;NPN,SI,TO-61	80009	151-0703-00
A30A1Q2071	151-0703-00			TRANSISTOR;NPN,SI,TO-61	80009	151-0703-00
A30A1Q3022	151-0625-00			TRANSISTOR,PWR:BIPOLAR,PNP;80V,10A,40MHZ,AMPLIFIER;D45H11,TO-220	80009	151-0625-00
A30A1Q3023	151-0301-00			TRANSISTOR,SIG:BIPOLAR,PNP;60V,600MA,200MHZ,AMPLIFIER;2N2907A,TO-18	80009	151-0301-00
A30A1Q5013	151-0622-00			TRANSISTOR,SIG:BIPOLAR,PNP;40V,1.0A,50MHZ,AMPLIFIER;2N6727/MPS6727/MPSW51A,TO-237/TO-226AE EBC	80009	151-0622-00
A30A1Q5023	151-0302-00			TRANSISTOR,SIG:BIPOLAR,NPN;40V,800MA,300MHZ,AMPLIFIER;2N2222A,TO-18	80009	151-0302-00
A30A1Q5032	151-0301-00			TRANSISTOR,SIG:BIPOLAR,PNP;60V,600MA,200MHZ,AMPLIFIER;2N2907A,TO-18	80009	151-0301-00
A30A1Q6034	151-0302-00			TRANSISTOR,SIG:BIPOLAR,NPN;40V,800MA,300MHZ,AMPLIFIER;2N2222A,TO-18	80009	151-0302-00
A30A1Q6077	151-0444-00			TRANSISTOR,SIG:BIPOLAR,NPN;350V,500MA,40MHZ,AMPLIFIER;2N6517,TO-92 EBC	80009	151-0444-00
A30A1Q6078	151-0444-00			TRANSISTOR,SIG:BIPOLAR,NPN;350V,500MA,40MHZ,AMPLIFIER;2N6517,TO-92 EBC	80009	151-0444-00
A30A1R2015	308-0643-00			RES,FXD,WW:0.10 OHM,3%,3W	07088	
A30A1R2017	308-0680-00			RES,FXD,WW:0.045 OHM,10%,3W	80009	308-0680-00
A30A1R2022	315-0562-00			RES,FXD,FILM:5.6K OHM,5%,0.25W	80009	315-0562-00
A30A1R2025	315-0122-00			RES,FXD,FILM:1.2K OHM,5%,0.25W	80009	315-0122-00
A30A1R2026	321-0399-00			RES,FXD,FILM:140K OHM,1%,0.125W,TC=T0	07716	CEAD14002F
A30A1R2030	315-0242-00			RES,FXD,FILM:2.4K OHM,5%,0.25W	80009	315-0242-00
A30A1R2031	307-0106-00			RES,FXD,CMPNSN:4.7 OHM,5%,0.25W	01121	CB4765
A30A1R2032	321-0193-00			RES,FXD,FILM:1K OHM,1%,0.125W,TC=T0	80009	321-0193-00
A30A1R2034	315-0102-00			RES,FXD,FILM:1K OHM,5%,0.25W	80009	315-0102-00
A30A1R2035	315-0621-00			RES,FXD,FILM:620 OHM,5%,0.25W	80009	315-0621-00
A30A1R2036	321-0289-07			RES,FXD,FILM:10.0K OHM,0.1%,0.125W,TC=T9	80009	321-0289-07
A30A1R2037	321-0318-07			RES,FXD,FILM:20.0K OHM,0.1%,0.125W,TC=T9	2M627	CRA16Z20KOHM
A30A1R2038	321-0381-00			RES,FXD,FILM:90.9K OHM,1%,0.125W,TC=T0	07716	CEAD0901F
A30A1R2039	321-0347-00			RES,FXD,FILM:40.2K OHM,1%,0.125W,TC=T0	80009	321-0347-00
A30A1R2057	315-0105-00			RES,FXD,FILM:1M OHM,5%,0.25W	80009	315-0105-00
A30A1R2073	315-0105-00			RES,FXD,FILM:1M OHM,5%,0.25W	80009	315-0105-00
A30A1R3019	308-0463-00			RES,FXD,WW:0.3 OHM,1%,3W	80009	308-0463-00
A30A1R3021	315-0102-00			RES,FXD,FILM:1K OHM,5%,0.25W	80009	315-0102-00
A30A1R3022	307-0106-00			RES,FXD,CMPNSN:4.7 OHM,5%,0.25W	01121	CB4765
A30A1R3023	315-0102-00			RES,FXD,FILM:1K OHM,5%,0.25W	80009	315-0102-00
A30A1R3024	301-0102-00			RES,FXD,CMPNSN:1K OHM,5%,0.50W	01121	EB1025
A30A1R3025	315-0102-00			RES,FXD,FILM:1K OHM,5%,0.25W	80009	315-0102-00
A30A1R3026	315-0271-00			RES,FXD,FILM:270 OHM,5%,0.25W	80009	315-0271-00
A30A1R3029	307-0106-00			RES,FXD,CMPNSN:4.7 OHM,5%,0.25W	01121	CB4765
A30A1R3031	321-0377-00			RES,FXD,FILM:82.5K OHM,1%,0.125W,TC=T0	07716	CEAD82501F
A30A1R3032	321-0193-00			RES,FXD,FILM:1K OHM,1%,0.125W,TC=T0	80009	321-0193-00
A30A1R3033	307-0106-00			RES,FXD,CMPNSN:4.7 OHM,5%,0.25W	01121	CB4765
A30A1R3034	321-0378-00	B010100	B010249	RES,FXD,FILM:84.5K OHM,1%,0.125W,TC=T0	07716	CEAD84501F
A30A1R3034	321-0367-00	B010250		RES,FXD,FILM:64.9K OHM,1%,0.125W,TC=T0	07716	CEAD64901F
A30A1R3036	321-0193-00			RES,FXD,FILM:1K OHM,1%,0.125W,TC=T0	80009	321-0193-00
A30A1R3037	321-0604-00			RES,FXD,FILM:30K OHM,0.25%,0.125W,TC=T2	80009	321-0604-00
A30A1R3038	321-0344-00	B010100	B010249	RES,FXD,FILM:37.4K OHM,1%,0.125W,TC=T0	19701	5033ED 37K40F
A30A1R3038	321-0353-00	B010250		RES,FXD,FILM:46.4K OHM,1%,0.125W,TC=T0	07716	CEAD46401F
A30A1R3039	321-0289-03			RES,FXD,FILM:10.0K OHM,0.25%,0.125W,TC=T2	07716	CEAC10001C
A30A1R3084	303-0271-00			RES,FXD,CMPNSN:270 OHM,5%,1W	01121	GB2715
A30A1R3088	301-0823-00			RES,FXD,FILM:82K OHM,5%,0.5W	80009	301-0823-00
A30A1R4017	301-0823-00			RES,FXD,FILM:82K OHM,5%,0.5W	80009	301-0823-00
A30A1R4018	301-0165-00			RES,FXD,FILM:1.6M OHM,5%,0.5W	57668	TR50J-E 1M6
A30A1R4031	315-0102-00			RES,FXD,FILM:1K OHM,5%,0.25W	80009	315-0102-00

Replaceable Electrical Parts
494A/494AP Service Vol.2

Component No.	Tektronix Part No.	Serial/Assembly No. Effective Dscont	Name & Description	Mfr. Code	Mfr. Part No.
A30A1R4083	315-0471-00		RES,FXD,FILM:470 OHM,5%,0.25W	80009	315-0471-00
A30A1R4092	308-0054-00		RES,FXD,WW:10K OHM,5%,5W	00213	1550S-10000-5
A30A1R5014	321-0193-00		RES,FXD,FILM:1K OHM,1%,0.125W,TC=TO	80009	321-0193-00
A30A1R5015	321-0385-00		RES,FXD,FILM:100K OHM,1%,0.125W,TC=TO	80009	321-0385-00
A30A1R5016	307-0103-00		RES,FXD,CMPSN:2.7 OHM,5%,0.25W	80009	307-0103-00
A30A1R5019	315-0362-00		RES,FXD,FILM:3.6K OHM,5%,0.25W	80009	315-0362-00
A30A1R5033	315-0182-00		RES,FXD,FILM:1.8K OHM,5%,0.25W	80009	315-0182-00
A30A1R5034	315-0222-00		RES,FXD,FILM:2.2K OHM,5%,0.25W	80009	315-0222-00
A30A1R5035	315-0622-00		RES,FXD,FILM:6.2K OHM,5%,0.25W	80009	315-0622-00
A30A1R5036	321-0381-00		RES,FXD,FILM:90.9K OHM,1%,0.125W,TC=TO	07716	CEAD90901F
A30A1R5039	301-0102-00		RES,FXD,CMPSN:1K OHM,5%,0.50W	01121	EB1025
A30A1R5042	315-0512-00		RES,FXD,FILM:5.1K OHM,5%,0.25W	80009	315-0512-00
A30A1R5042	315-0332-00		RES,FXD,FILM:3.3K OHM,5%,0.25W	80009	315-0332-00
A30A1R5043	315-0103-00		RES,FXD,FILM:10K OHM,5%,0.25W	80009	315-0103-00
A30A1R5047	321-0373-00		RES,FXD,FILM:75.0K OHM,1%,0.125W,TC=TO	19701	5033ED75K00F
A30A1R5083	307-0023-00		RES,FXD,CMPSN:4.7 OHM,10%,0.5W	80009	307-0023-00
A30A1R5086	307-0023-00		RES,FXD,CMPSN:4.7 OHM,10%,0.5W	80009	307-0023-00
A30A1R5087	308-0154-00		RES,FXD,WW:25K OHM,5%,10W	80009	308-0154-00
A30A1R5111	301-0565-00		RES,FXD,FILM:5.6M OHM,5%,0.05W	80009	301-0565-00
A30A1R6011	321-0289-00		RES,FXD,FILM:10.0K OHM,1%,0.125W,TC=TO	57668	FXE10K0
A30A1R6013	307-0106-00		RES,FXD,CMPSN:4.7 OHM,5%,0.25W	01121	CB47G5
A30A1R6017	307-0106-00		RES,FXD,CMPSN:4.7 OHM,5%,0.25W	01121	CB47G5
A30A1R6019	321-0289-03		RES,FXD,FILM:10.0K OHM,0.25%,0.125W,TC=T2	07716	CEAC10001C
A30A1R6020	321-0183-00		RES,FXD,FILM:787 OHM,1%,0.125W,TC=TO	07716	CEAD787ROF
A30A1R6021	315-0361-00		RES,FXD,FILM:360 OHM,5%,0.25W	80009	315-0361-00
A30A1R6022	315-0103-00		RES,FXD,FILM:10K OHM,5%,0.25W	80009	315-0103-00
A30A1R6023	321-0227-00		RES,FXD,FILM:2.26K OHM,1%,0.125W,TC=TO	01121	RNK2261F
A30A1R6024	321-0289-03		RES,FXD,FILM:10.0K OHM,0.25%,0.125W,TC=T2	07716	CEAC10001C
A30A1R6028	311-1489-00		RES,VAR,NONWW:500 OHM,10%,0.75W	02111	43P501T672
A30A1R6029	321-0114-00		RES,FXD,FILM:150 OHM,1%,0.125 W,TC=TO	80009	321-0114-00
A30A1R6032	321-0317-00		RES,FXD,FILM:19.6K OHM,1%,0.125W,TC=TO	07716	CEAD19601F
A30A1R6033	315-0103-00		RES,FXD,FILM:10K OHM,5%,0.25W	80009	315-0103-00
A30A1R6035	315-0105-00		RES,FXD,FILM:1M OHM,5%,0.25W	80009	315-0105-00
A30A1R6037	321-0816-00		RES,FXD,FILM:5K OHM,1%,0.125W,TC=TO	07716	
A30A1R6038	321-0299-00		RES,FXD,FILM:12.7K OHM,1%,0.125W,TC=TO	80009	321-0299-00
A30A1R6040	315-0302-00		RES,FXD,FILM:3K OHM,5%,0.25W	80009	315-0302-00
A30A1R6041	315-0512-00		RES,FXD,FILM:5.1K OHM,5%,0.25W	80009	315-0512-00
A30A1R6045	315-0103-00		RES,FXD,FILM:10K OHM,5%,0.25W	80009	315-0103-00
A30A1R6046	315-0820-00		RES,FXD,FILM:82 OHM,5%,0.25W	80009	315-0820-00
A30A1R6048	321-0337-00		RES,FXD,FILM:31.6K OHM,1%,0.125W,TC=TO	07716	CEAD31601F
A30A1R6052	321-0250-00		RES,FXD,FILM:3.92K OHM,1%,0.125W,TC=TO	07716	CEAD39200F
A30A1R6056	321-0337-00		RES,FXD,FILM:31.6K OHM,1%,0.125W,TC=TO	07716	CEAD31601F
A30A1R6057	321-0321-00		RES,FXD,FILM:21.5K OHM,1%,0.125W,TC=TO	07716	CEAD21501F
A30A1R6058	321-0230-00		RES,FXD,FILM:2.43K OHM,1%,0.125W,TC=TO	80009	321-0230-00
A30A1R6061	311-0644-00		RES,VAR,NONWW:TRMR,20K OHM,0.5W	80009	311-0644-00
A30A1R6063	315-0205-00		RES,FXD,FILM:2M OHM,5%,0.25W	80009	315-0205-00
A30A1R6073	315-0122-00		RES,FXD,FILM:1.2K OHM,5%,0.25W	80009	315-0122-00
A30A1R6074	315-0103-00		RES,FXD,FILM:10K OHM,5%,0.25W	80009	315-0103-00
A30A1R6075	315-0122-00		RES,FXD,FILM:1.2K OHM,5%,0.25W	80009	315-0122-00
A30A1R6076	315-0103-00		RES,FXD,FILM:10K OHM,5%,0.25W	80009	315-0103-00
A30A1R6091	308-0054-00		RES,FXD,WW:10K OHM,5%,5W	00213	1550S-10000-5
A30A1RT2093	307-0353-00		RES,THERMAL:5 OHM,10%	80009	307-0353-00
A30A1RT2097	307-0353-00		RES,THERMAL:5 OHM,10%	80009	307-0353-00
A30A1S2103	159-0169-00		FUSE,THERMAL:15A,1200V,104 DEG C	27012	4218A1
A30A1T2080	120-1287-00		TRANSFORMER,RF:TOROID	80009	120-1287-00
A30A1T4071	120-1239-00		XFMR,PWR,SDN&SU:HF	80009	120-1239-00
A30A1T4084	120-0640-00		XFMR,TOROID:	TK1345	120-0640-00
A30A1T6044	120-1350-00		TRANSFORMER,RF:TOROID	80009	120-1350-00

Replaceable Electrical Parts
494A/494AP Service Vol.2

Component No.	Tektronix Part No.	Serial/Assembly No. Effective	Discont	Name & Description	Mfr. Code	Mfr. Part No.
A30A1T6081	120-1234-01			TRANSFORMER, RF: BASE DRIVE	80009	120-1234-01
A30A1U2037	156-0495-02	B010100	B010502	IC, LINEAR: BIPOLAR, OP-AMP; DUPLICATE OF 156-0495-00, DO NOT USE; LM324N, DIP14.3	80009	156-0495-02
A30A1U2037	156-0495-00	B010503		IC, LINEAR: BIPOLAR, OP-AMP; QUAD, SINGLE SUPPLY; LM324N, DIP14.3	80009	156-0495-00
A30A1U3036	156-0853-00			IC, LINEAR: BIPOLAR, OP-AMP; DUAL, SINGLE SUPPLY; LM358N, DIP08.3	80009	156-0853-00
A30A1U3093	119-1168-00			CAPACITOR-RES: 0.1UF, 20% & 22 OHM, 10%, 250VAC	14752	RG1782-1
A30A1U3103	119-1168-00			CAPACITOR-RES: 0.1UF, 20% & 22 OHM, 10%, 250VAC	14752	RG1782-1
A30A1U5043	156-1689-00			CPLR, OPTOELECTR: LED & PHOTOTRANSISTOR, 3750V ISOLATION	80009	156-1689-00
A30A1U6016	156-0853-00			IC, LINEAR: BIPOLAR, OP-AMP; DUAL, SINGLE SUPPLY; LM358N, DIP08.3	80009	156-0853-00
A30A1U6036	156-1126-00			IC, LINEAR: BIPOLAR, COMPARATOR; OPEN COLLECTOR, 200NS; LM311N, DIP08.3	80009	156-1126-00
A30A1U6043	156-1162-00			CPLR, OPTOELECTR: LED, 2500V	50438	6N136
A30A1U6046	156-1225-00			IC, LINEAR: BIPOLAR, COMPARATOR; DUAL, OPEN COLL ECTOR, 300NS; LM393N, DIP08.3	01295	LM393P
A30A1U6053	156-1408-00			IC, MISC: CMOS, TIMER; ; ICM75551PA, DIP08.3	80009	156-1408-00
A30A1U6059	156-1408-00			IC, MISC: CMOS, TIMER; ; ICM75551PA, DIP08.3	80009	156-1408-00
A30A1U6063	156-0366-00			IC, DIGITAL: CMOS, FLIP FLOP; DUAL D-TYPE; 4013B, DIP14.3, TUBE	80009	156-0366-00
A30A1U6069	156-0793-00			IC, DIGITAL: CMOS, GATE; DUAL 4-INPUT NAND; 4012B, DIP14.3, TUBE	80009	156-0793-00
A30A1VR3089	152-0405-00			DIODE, ZENER: .; 15V, 5%, 1W; 1N4744A, DO-41	12954	DZ841205A
A30A1VR5073	152-0149-00			DIODE, ZENER: .; 10V, 5%, 0.4W; 1N961B, DO-7 OR 35, T&R	04713	1N961B
A30A1VR6026	152-0486-00			DIODE, ZENER: .; 6.2V, 2%, 0.4W; 1N825 FMLY, DO-35 OR 7, TR	80009	152-0486-00
A30A2	670-7226-00			CIRCUIT BD ASSY: FAN DRIVE	80009	670-7226-00
A30A2C1017	283-0024-00			CAP, FXD, CER DI: 0.1UF, +80-20%, 50V	05397	C330C10Y25U1CA
A30A2C1018	283-0198-00			CAP, FXD, CER DI: 0.22UF, 20%, 50V	05397	C330C224M5U1CA
A30A2C1019	283-0198-00			CAP, FXD, CER DI: 0.22UF, 20%, 50V	05397	C330C224M5U1CA
A30A2C1026	290-0523-00			CAP, FXD, ELCTLT: 2.2UF, 20%, 20V	80009	290-0523-00
A30A2C1028	290-0523-00			CAP, FXD, ELCTLT: 2.2UF, 20%, 20V	80009	290-0523-00
A30A2C1032	290-0804-00			CAP, FXD, ELCTLT: 10UF, +50-20%, 25V	80009	290-0804-00
A30A2C1033	290-0804-00			CAP, FXD, ELCTLT: 10UF, +50-20%, 25V	80009	290-0804-00
A30A2C2012	290-0804-00			CAP, FXD, ELCTLT: 10UF, +50-20%, 25V	80009	290-0804-00
A30A2C2018	283-0198-00			CAP, FXD, CER DI: 0.22UF, 20%, 50V	05397	C330C224M5U1CA
A30A2C2028	290-0523-00			CAP, FXD, ELCTLT: 2.2UF, 20%, 20V	80009	290-0523-00
A30A2CR1039	152-0066-00			DIODE, RECT: .; 400V, 1A, IFSM = 30A; GP10G, DO-41, T&R, SAFETY CONTROLLED	05828	GP10G-020
A30A2CR2040	152-0066-00			DIODE, RECT: .; 400V, 1A, IFSM = 30A; GP10G, DO-41, T&R, SAFETY CONTROLLED	05828	GP10G-020
A30A2Q1010	151-0521-00			THYRISTOR, PWR: BIPOLAR, SCR; 200V, 8.0A RMS, PHASE CONTROL; C122B, TO-220	02735	C122B1
A30A2Q1018	151-0188-00			TRANSISTOR, SIG: BIPOLAR, PNP; 40V, 200MA, 250MHZ, AMPLIFIER; 2N3906, TO-92 EBC	80009	151-0188-00
A30A2Q1020	151-0188-00			TRANSISTOR, SIG: BIPOLAR, PNP; 40V, 200MA, 250MHZ, AMPLIFIER; 2N3906, TO-92 EBC	80009	151-0188-00
A30A2Q1025	151-0302-00			TRANSISTOR, SIG: BIPOLAR, NPN; 40V, 800MA, 300MHZ, AMPLIFIER; 2N2222A, TO-18	80009	151-0302-00
A30A2Q1038	151-0302-00			TRANSISTOR, SIG: BIPOLAR, NPN; 40V, 800MA, 300MHZ, AMPLIFIER; 2N2222A, TO-18	80009	151-0302-00
A30A2Q1044	151-0302-00			TRANSISTOR, SIG: BIPOLAR, NPN; 40V, 800MA, 300MHZ, AMPLIFIER; 2N2222A, TO-18	80009	151-0302-00
A30A2Q2020	151-0188-00			TRANSISTOR, SIG: BIPOLAR, PNP; 40V, 200MA, 250MHZ, AMPLIFIER; 2N3906, TO-92 EBC	80009	151-0188-00

Replaceable Electrical Parts
494A/494AP Service Vol. 2

Component No.	Tektronix Part No.	Serial/Assembly No. Effective Dscont	Name & Description	Mfr. Code	Mfr. Part No.
A30A2Q2025	151-0334-00		TRANSISTOR, PWR: BIPOLAR, NPN; 80V, 3.0A, 3.0MHZ, AMPLIFIER; 2N4923, TO-126	80009	151-0334-00
A30A2Q2030	151-0302-00		TRANSISTOR, SIG: BIPOLAR, NPN; 40V, 800MA, 300MHZ, AMPLIFIER; 2N2222A, TO-18	80009	151-0302-00
A30A2R1015	315-0270-00		RES, FXD, FILM: 27 OHM, 5%, 0.25W	80009	315-0270-00
A30A2R1017	315-0101-00		RES, FXD, FILM: 100 OHM, 5%, 0.25W	80009	315-0101-00
A30A2R1024	315-0681-00		RES, FXD, FILM: 680 OHM, 5%, 0.25W	80009	315-0681-00
A30A2R1026	315-0681-00		RES, FXD, FILM: 680 OHM, 5%, 0.25W	80009	315-0681-00
A30A2R1027	315-0104-00		RES, FXD, FILM: 100K OHM, 5%, 0.25W	80009	315-0104-00
A30A2R1028	315-0163-00		RES, FXD, FILM: 16K OHM, 5%, 0.25W	80009	315-0163-00
A30A2R1029	315-0223-00		RES, FXD, FILM: 22K OHM, 5%, 0.25W	80009	315-0223-00
A30A2R1031	315-0473-00		RES, FXD, FILM: 47K OHM, 5%, 0.25W	80009	315-0473-00
A30A2R1032	315-0163-00		RES, FXD, FILM: 16K OHM, 5%, 0.25W	80009	315-0163-00
A30A2R1033	315-0393-00		RES, FXD, FILM: 39K OHM, 5%, 0.25W	80009	315-0393-00
A30A2R1036	315-0223-00		RES, FXD, FILM: 22K OHM, 5%, 0.25W	80009	315-0223-00
A30A2R2014	315-0333-00		RES, FXD, FILM: 33K OHM, 5%, 0.25W	80009	315-0333-00
A30A2R2016	315-0104-00		RES, FXD, FILM: 100K OHM, 5%, 0.25W	80009	315-0104-00
A30A2R2019	315-0104-00		RES, FXD, FILM: 100K OHM, 5%, 0.25W	80009	315-0104-00
A30A2R2034	315-0163-00		RES, FXD, FILM: 16K OHM, 5%, 0.25W	80009	315-0163-00
A30A2R2035	315-0681-00		RES, FXD, FILM: 680 OHM, 5%, 0.25W	80009	315-0681-00
A30A2R2036	315-0223-00		RES, FXD, FILM: 22K OHM, 5%, 0.25W	80009	315-0223-00
A30A2R2037	315-0104-00		RES, FXD, FILM: 100K OHM, 5%, 0.25W	80009	315-0104-00
A30A2R2039	315-0361-00		RES, FXD, FILM: 360 OHM, 5%, 0.25W	80009	315-0361-00
A30A2R2042	315-0623-00		RES, FXD, FILM: 62K OHM, 5%, 0.25W	80009	315-0623-00
A30A2RT045	307-0472-00		RES, THERMAL: 100K OHM, 5%, DISC NTC	80009	307-0472-00
A30A2VR1015	152-0175-00		DIODE, ZENER: ., 5.6V, 5%, 0.4W; 1N752A, DO-7 OR 3 5, TR	14552	TD381097E
A30A2VR2038	152-0166-00		DIODE, ZENER: ., 6.2V, 5%, 0.4W; 1N753A, DO-7 OR 3 5, TR	80009	152-0166-00
A30A57	670-9841-00		CIRCUIT BD ASSY: GPIB INTERFACE (494A ONLY)	80009	670-9841-00
A30A57	670-9806-00		CIRCUIT BD ASSY: GPIB INTERFACE (494AP ONLY)	80009	670-9806-00
A30A57C1011	290-0524-00		CAP, FXD, ELCTLT: 4.7UF, 20%, 10V	05397	T368A475M010AZ
A30A57C1012	283-0111-00		CAP, FXD, CER DI: 0.1UF, 20%, 50V	80009	283-0111-00
A30A57C1013	283-0111-00		CAP, FXD, CER DI: 0.1UF, 20%, 50V	80009	283-0111-00
A30A57L1011	108-0836-00		COIL, RF: FIXED, 14UH	80009	108-0836-00
A30A57P1011	131-0608-00		TERMINAL, PIN: 0.365 L X 0.025 BRZ GLD PL	80009	131-0608-00
A30A57P1012	131-2203-02		CONN, RIBBON: PCB; FEMALE, STR, 24 POS, 0.085 CT R, 0.135 TAIL, W/FLOAT BUSHING; .,	29587	57-20240-11(398)
A30A57P1013	131-2581-00		CONN, BOX: .	91506	528-AG29D
A30A57R1011	317-0103-00		RES, FXD, CMPSN: 10K OHM, 5%, 0.125W	80009	317-0103-00
A30A57S1011	260-1721-00		SWITCH, ROCKER: 8, SPST, 125MA, 30VDC	81073	76SB08S
A30A57U1011	156-1415-01		MICROCKT, DGTL: OCTAL GPIB XCVR-MANAGEMENT	27014	DS75161A NA+
A30A57U1012	156-1414-00		IC, DIGITAL: LSTTL, TRANSCEIVER: OCTAL IEEE-488 GPIB BUS XCVR; 75160, DIP20.3	80009	156-1414-00
A30A76	670-5558-02		CIRCUIT BD ASSY: ACCESSORIES INTERFACE; ; 388-6085-XX WIRED	80009	670-5558-02
A30A76C2012	283-0111-00		CAP, FXD, CER DI: 0.1UF, 20%, 50V	80009	283-0111-00
A30A76C2024	283-0111-00		CAP, FXD, CER DI: 0.1UF, 20%, 50V	80009	283-0111-00
A30A76C2036	283-0111-00		CAP, FXD, CER DI: 0.1UF, 20%, 50V	80009	283-0111-00
A30A76C2038	283-0111-00		CAP, FXD, CER DI: 0.1UF, 20%, 50V	80009	283-0111-00
A30A76CR1013	152-0322-00		DIODE, SIG: SCHTKY, ; 15V, 410MWF AT 1MA, 1.2PF; 5082-2811, T&R	80009	152-0322-00
A30A76J1017	131-1437-00		CONN, RCPT, ELEC: D SER, 25 FEM CONT	71468	DB25S-F179
A30A76J1034	131-2323-00		CONN, EDGE CARD: .	31781	307-024-526-300
A30A76R1013	315-0202-00		RES, FXD, FILM: 2K OHM, 5%, 0.25W	80009	315-0202-00
A30A76R2019	315-0103-00		RES, FXD, FILM: 10K OHM, 5%, 0.25W	80009	315-0103-00

Replaceable Electrical Parts
494A/494AP Service Vol.2

Component No.	Tektronix Part No.	Serial/Assembly No. Effective	Discont	Name & Description	Mfr. Code	Mfr. Part No.
A30A76R2038	315-0472-00			RES,FXD,FILM:4.7K OHM,5%,0.25W	80009	315-0472-00
A30A76U2015	156-1111-00			IC,DIGITAL:LS TTL,TRANSCEIVER;OCTAL NONINV,3-STATE;74LS245,DIP20.3,TUBE	80009	156-1111-00
A30A76U2025	156-1111-00			IC,DIGITAL:LS TTL,TRANSCEIVER;OCTAL NONINV,3-STATE;74LS245,DIP20.3,TUBE	80009	156-1111-00
A30A76U2033	156-1111-00			IC,DIGITAL:LS TTL,TRANSCEIVER;OCTAL NONINV,3-STATE;74LS245,DIP20.3,TUBE	80009	156-1111-00
A30A76U2038	156-0381-00			IC,DIGITAL:LS TTL,GATES;QUAD 2-INPUT XOR;74LS86,DIP14.3,TUBE	80009	156-0381-00
A32	119-1015-00	B010100	B010221	FILTER,AMPL:110MHZ	80009	119-1015-00
A32	119-1015-01	B010222		FILTER,AMPL:110MHZ	80009	119-1015-01
A32C321	281-0825-00			CAP,FXD,CER DI:0.005UF,+100-0%,100V	33095	51-726-008
A32C323	281-0825-00			CAP,FXD,CER DI:0.005UF,+100-0%,100V	33095	51-726-008
A32C1054	281-0165-00			CAP,VAR,AIR DI:0.8-10PF,250V	80009	281-0165-00
A32P320	131-0938-00			CONN,RF JACK::SMB/PNL,;MALE,STR,50 OHM,0.25 HEX,2.0 L 0.025 DIA TAIL,10-32 THD,REAR MT	24931	32JR125-1
A32P321	131-0938-00			CONN,RF JACK::SMB/PNL,;MALE,STR,50 OHM,0.25 HEX,2.0 L 0.025 DIA TAIL,10-32 THD,REAR MT	24931	32JR125-1
A32Q3018	151-0650-00			TRANSISTOR,SIG:BIPOLAR,NPN;25V,300MA,1.4GHZ ,AMPLIFIER;NE74114/2SC1252,TO-39	S0545	2SC1252
A32A1	-----			CKT BOARD ASSY:110 IF (PART OF A32)		
A32A1C1012	283-0204-00			CAP,FXD,CER DI:0.01UF,20%,50V	51406	RPE110Z5U103M50V
A32A1C1022	283-0204-00			CAP,FXD,CER DI:0.01UF,20%,50V	51406	RPE110Z5U103M50V
A32A1C2010	283-0204-00			CAP,FXD,CER DI:0.01UF,20%,50V	51406	RPE110Z5U103M50V
A32A1C2012	283-0204-00			CAP,FXD,CER DI:0.01UF,20%,50V	51406	RPE110Z5U103M50V
A32A1C2029	283-0204-00			CAP,FXD,CER DI:0.01UF,20%,50V	51406	RPE110Z5U103M50V
A32A1C2035	283-0111-00			CAP,FXD,CER DI:0.1UF,20%,50V	80009	283-0111-00
A32A1C2036	290-0574-00			CAP,FXD,ELCTLT:47UF,10%,20V	05397	T368C476K0202AS
A32A1C2037	283-0204-00			CAP,FXD,CER DI:0.01UF,20%,50V	51406	RPE110Z5U103M50V
A32A1C2047	281-0164-00			CAP,VAR,AIR DI:0.6-6PF,250V	80009	281-0164-00
A32A1C2051	283-0204-00			CAP,FXD,CER DI:0.01UF,20%,50V	51406	RPE110Z5U103M50V
A32A1C3032	283-0111-00			CAP,FXD,CER DI:0.1UF,20%,50V	80009	283-0111-00
A32A1C3036	283-0204-00			CAP,FXD,CER DI:0.01UF,20%,50V	51406	RPE110Z5U103M50V
A32A1C3043	283-0204-00			CAP,FXD,CER DI:0.01UF,20%,50V	51406	RPE110Z5U103M50V
A32A1C3044	283-0204-00			CAP,FXD,CER DI:0.01UF,20%,50V	51406	RPE110Z5U103M50V
A32A1C3045	283-0204-00			CAP,FXD,CER DI:0.01UF,20%,50V	51406	RPE110Z5U103M50V
A32A1C4020	283-0204-00			CAP,FXD,CER DI:0.01UF,20%,50V	51406	RPE110Z5U103M50V
A32A1C4026	283-0204-00			CAP,FXD,CER DI:0.01UF,20%,50V	51406	RPE110Z5U103M50V
A32A1C4035	283-0204-00			CAP,FXD,CER DI:0.01UF,20%,50V	51406	RPE110Z5U103M50V
A32A1C4036	283-0204-00			CAP,FXD,CER DI:0.01UF,20%,50V	51406	RPE110Z5U103M50V
A32A1C4045	283-0156-00			CAP,FXD,CER DI:1000PF,+80-20%,200V	04222	SR152E10Z2AA
A32A1CR1029	152-0579-00	B010100	B010221	SEMICON DVC,DI:SW,SI,100V,2.5A,A196P	80009	152-0579-00
A32A1CR1029	152-0524-00	B010222		DIODE,SIG:,PIN;100V,0.4PF,2.5 OHM;MA47600,D 0-35	28480	5082-1779
A32A1CR3030	152-0579-00	B010100	B010221	SEMICON DVC,DI:SW,SI,100V,2.5A,A196P	80009	152-0579-00
A32A1CR3030	152-0524-00	B010222		DIODE,SIG:,PIN;100V,0.4PF,2.5 OHM;MA47600,D 0-35	28480	5082-1779
A32A1E3036	276-0507-00			SHLD BEAD,ELEK:FERRITE	02114	56-590-65B/3B
A32A1E4046	276-0507-00			SHLD BEAD,ELEK:FERRITE	02114	56-590-65B/3B
A32A1E4053	276-0569-00	B010222		CORE,EM:TOROID,FERRITE	80009	276-0569-00
A32A1L1039	108-0395-00			COIL,RF:FIXED,64UH	80009	108-0395-00
A32A1L2044	108-0956-00			COIL,RF:FIXED	80009	108-0956-00
A32A1Q4037	151-0650-00			TRANSISTOR,SIG:BIPOLAR,NPN;25V,300MA,1.4GHZ ,AMPLIFIER;NE74114/2SC1252,TO-39	S0545	2SC1252
A32A1Q4053	151-0650-00			TRANSISTOR,SIG:BIPOLAR,NPN;25V,300MA,1.4GHZ ,AMPLIFIER;NE74114/2SC1252,TO-39	S0545	2SC1252
A32A1R1012	301-0330-00			RES,FXD,FILM:33 OHM,5%,0.5W	19701	5053CX33R00J

Replaceable Electrical Parts
494A/494AP Service Vol.2

Component No.	Tektronix	Serial/Assembly No.	Name & Description	Mfr.	Mfr. Part No.
	Part No.	Effective Dscnt		Code	
A32A1R1015	311-1281-00		RES,VAR,NONWV:TRMR,2.5K OHM,0.5W	80009	311-1281-00
A32A1R2014	315-0102-00		RES,FXD,FILM:1K OHM,5%,0.25W	80009	315-0102-00
A32A1R2019	315-0511-00		RES,FXD,FILM:510 OHM,5%,0.25W	80009	315-0511-00
A32A1R2028	321-0210-00		RES,FXD,FILM:1.50K OHM,1%,0.125W,TC=T0	80009	321-0210-00
A32A1R2029	321-0289-00		RES,FXD,FILM:10.0K OHM,1%,0.125W,TC=T0	57668	FXE10K0
A32A1R2030	315-0101-00		RES,FXD,FILM:100 OHM,5%,0.25W	80009	315-0101-00
A32A1R2032	317-0510-00		RES,FXD,CMPNSN:51 OHM,5%,0.125W	80009	317-0510-00
A32A1R2038	317-0180-00		RES,FXD,CMPNSN:18 OHM,5%,0.125W	80009	317-0180-00
A32A1R2039	317-0301-00		RES,FXD,CMPNSN:300 OHM,5%,0.125W	80009	317-0301-00
A32A1R2043	317-0301-00		RES,FXD,CMPNSN:300 OHM,5%,0.125W	80009	317-0301-00
A32A1R3014	315-0202-00		RES,FXD,FILM:2K OHM,5%,0.25W	80009	315-0202-00
A32A1R3029	317-0510-00		RES,FXD,CMPNSN:51 OHM,5%,0.125W	80009	317-0510-00
A32A1R3035	321-0239-00		RES,FXD,FILM:3.01K OHM,1%,0.125W,TC=T0	80009	321-0239-00
A32A1R3042	315-0271-00		RES,FXD,FILM:270 OHM,5%,0.25W	80009	315-0271-00
A32A1R4012	301-0330-00		RES,FXD,FILM:33 OHM,5%,0.5W	19701	5053CX33R00J
A32A1R4018	315-0681-00		RES,FXD,FILM:680 OHM,5%,0.25W	80009	315-0681-00
A32A1R4029	307-0113-00		RES,FXD,CMPNSN:5.1 OHM,5%,0.25W	01121	CB51G5
A32A1R4030	315-0222-00		RES,FXD,FILM:2.2K OHM,5%,0.25W	80009	315-0222-00
A32A1R4032	315-0681-00		RES,FXD,FILM:680 OHM,5%,0.25W	80009	315-0681-00
A32A1R4038	315-0101-00		RES,FXD,FILM:100 OHM,5%,0.25W	80009	315-0101-00
A32A1R4039	315-0222-00		RES,FXD,FILM:2.2K OHM,5%,0.25W	80009	315-0222-00
A32A1R4043	315-0221-00		RES,FXD,FILM:220 OHM,5%,0.25W	80009	315-0221-00
A32A1R4047	315-0681-00		RES,FXD,FILM:680 OHM,5%,0.25W	80009	315-0681-00
A32A1R4058	315-0241-00		RES,FXD,FILM:240 OHM,5%,0.25W	80009	315-0241-00
A32A1T2020	120-0902-00		XFMR,TOROID:	80009	120-0902-00
A32A1T3041	120-1235-00		TRANSFORMER,RF: BALUN	80009	120-1235-00
A32A1T3054	120-1235-00		TRANSFORMER,RF: BALUN	80009	120-1235-00
A34	119-1579-01		OSC/MIXER ASSY:3RD CONVERTER	80009	119-1579-01
A34C341	281-0697-00		CAP,FXD,CER DI:5000PF,+100-0%,100V	80009	281-0697-00
A34C342	281-0697-00		CAP,FXD,CER DI:5000PF,+100-0%,100V	80009	281-0697-00
A34C343	281-0697-00		CAP,FXD,CER DI:5000PF,+100-0%,100V	80009	281-0697-00
A34C344	281-0697-00		CAP,FXD,CER DI:5000PF,+100-0%,100V	80009	281-0697-00
A34P340	131-0951-01		CONN,RF JACK:	80009	131-0951-01
A34P341	131-0951-01		CONN,RF JACK:	80009	131-0951-01
A34P342	131-0951-01		CONN,RF JACK:	80009	131-0951-01
A34P344	131-0951-01		CONN,RF JACK:	80009	131-0951-01
A34P346	131-0951-01		CONN,RF JACK:	80009	131-0951-01
A34P347	131-0951-01		CONN,RF JACK:	80009	131-0951-01
A34U1017	156-0872-00		IC,LINER:BIPOLAR,VOLTAGE REGULATOR;NEGATIV	04713	MC7912CT
A34U1025	156-0285-00		E,-12V,1.0A,4%;MC7912CT,TO-220 IC,LINER:BIPOLAR,VOLTAGE REGULATOR;POSITIV E,12V,1.0A,4%;MC7812CT,TO-220	80009	156-0285-00
A34A1	-----		CKT BOARD ASSY:3RD CONVERTER (PART OF A34)		
A34A1C1026	283-0347-00		CAP,FXD,CER DI:68PF,5%,100V	72982	8121A108P3K680J
A34A1C1038	281-0165-00		CAP,VAR,AIR DI:0.8-10PF,250V	80009	281-0165-00
A34A1C1044	283-0191-00		CAP,FXD,CER DI:0.022UF,20%,50V	05397	C320C223M5U1CA
A34A1C1049	283-0191-00		CAP,FXD,CER DI:0.022UF,20%,50V	05397	C320C223M5U1CA
A34A1C2011	283-0223-00		CAP,FXD,CER DI:3PF,+/-5PF,50V	TK1134	835XXXCOJ0309D
A34A1C2021	283-0347-00		CAP,FXD,CER DI:68PF,5%,100V	72982	8121A108P3K680J
A34A1C2022	283-0223-00		CAP,FXD,CER DI:3PF,+/-5PF,50V	TK1134	835XXXCOJ0309D
A34A1C2023	283-0223-00		CAP,FXD,CER DI:3PF,+/-5PF,50V	TK1134	835XXXCOJ0309D
A34A1C2033	283-0191-00		CAP,FXD,CER DI:0.022UF,20%,50V	05397	C320C223M5U1CA
A34A1C2039	283-0107-00		CAP,FXD,CER DI:51PF,5%,200V	04222	SR292A510JAA
A34A1C2041	283-0168-00		CAP,FXD,CER DI:12PF,5%,100V	04222	SR151A120JAA
A34A1C2042	283-0140-00		CAP,FXD,CER DI:4.7PF,+/-0.25PF,50V	80009	283-0140-00
A34A1C2044	283-0191-00		CAP,FXD,CER DI:0.022UF,20%,50V	05397	C320C223M5U1CA
A34A1C2046	283-0191-00		CAP,FXD,CER DI:0.022UF,20%,50V	05397	C320C223M5U1CA

Replaceable Electrical Parts
494A/494AP Service Vol.2

Component No.	Tektronix Part No.	Serial/Assembly No. Effective Dscont	Name & Description	Mfr. Code	Mfr. Part No.
A34A1C3022	290-0804-00		CAP,FXD,ELCLTL:10UF,+50-20%,25V	80009	290-0804-00
A34A1C3036	283-0203-00		CAP,FXD,CER DI:0.47UF,20%,50V	80009	283-0203-00
A34A1C3041	283-0203-00		CAP,FXD,CER DI:0.47UF,20%,50V	80009	283-0203-00
A34A1C3046	283-0191-00		CAP,FXD,CER DI:0.022UF,20%,50V	05397	C320C223M5U1CA
A34A1C3055	290-0804-00		CAP,FXD,ELCLTL:10UF,+50-20%,25V	80009	290-0804-00
A34A1CR3039	152-0650-00		DIODE,SIG:VVC;30V,2.3PF@C25,C3/25=5.25;BB105B,PLASTIC STRIPLINE	50101	U11-4101
A34A1L1041	108-1129-00		COIL,RF:FIXED,96 NH	80009	108-1129-00
A34A1L2022	108-0606-00		COIL,RF:	80009	108-0606-00
A34A1L2023	108-0606-00		COIL,RF:	80009	108-0606-00
A34A1L2052	108-0436-00		COIL,RF:FIXED,240UH ON FORM	80009	108-0436-00
A34A1L3041	108-1161-00		COIL,RF:FXD,175NH	80009	108-1161-00
A34A1P2042	131-0608-00		TERMINAL,PIN:0.365 L X 0.025 BRZ GLD PL	80009	131-0608-00
A34A1Q2038	151-0282-00		TRANSISTOR,SIG:BIPOLAR,NPN;12V,50MA,900MHZ,AMPLIFIER;2N5179,TO-72	80009	151-0282-00
A34A1Q2041	151-0282-00		TRANSISTOR,SIG:BIPOLAR,NPN;12V,50MA,900MHZ,AMPLIFIER;2N5179,TO-72	80009	151-0282-00
A34A1Q2042	151-0282-00		TRANSISTOR,SIG:BIPOLAR,NPN;12V,50MA,900MHZ,AMPLIFIER;2N5179,TO-72	80009	151-0282-00
A34A1R1011	321-1068-07		RES,FXD,FILM:50.5 OHM,0.1%,0.125W,TC=T9	80009	321-1068-07
A34A1R1021	321-0306-00		RES,FXD,FILM:15.0K OHM,1%,0.125W,TC=T0	80009	321-0306-00
A34A1R1022	321-0243-00		RES,FXD,FILM:3.32K OHM,1%,0.125W,TC=T0	80009	321-0243-00
A34A1R1024	317-0302-00		RES,FXD,CMPSN:3K OHM,5%,0.125W	80009	317-0302-00
A34A1R1041	311-1261-00		RES,VAR,NONW:TRMR,500 OHM,0.5W	80009	311-1261-00
A34A1R1042	321-0960-07		RES,FXD,FILM:513 OHM,0.1%,0.125W,TC=T9	2M627	CRA18875130HM
A34A1R1043	321-0239-03		RES,FXD,FILM:3.0K OHM,0.25%,0.125W,TC=T2	80009	321-0239-03
A34A1R1044	317-0100-00		RES,FXD,CMPSN:10 OHM,5%,0.125W	80009	317-0100-00
A34A1R1045	317-0201-00		RES,FXD,CMPSN:200 OHM,5%,0.125W	80009	317-0201-00
A34A1R1048	317-0201-00		RES,FXD,CMPSN:200 OHM,5%,0.125W	80009	317-0201-00
A34A1R1051	315-0132-00		RES,FXD,FILM:1.3K OHM,5%,0.25W	80009	315-0132-00
A34A1R2011	321-0193-07		RES,FXD,FILM:1K OHM,0.1%,0.125W,TC=T9	80009	321-0193-07
A34A1R2038	317-0680-00		RES,FXD,CMPSN:68 OHM,5%,0.125W	80009	317-0680-00
A34A1R2042	317-0750-00		RES,FXD,CMPSN:75 OHM,5%,0.125W	80009	317-0750-00
A34A1R2044	315-0911-00		RES,FXD,FILM:910 OHM,5%,0.25W	80009	315-0911-00
A34A1R2045	317-0201-00		RES,FXD,CMPSN:200 OHM,5%,0.125W	80009	317-0201-00
A34A1R2046	317-0201-00		RES,FXD,CMPSN:200 OHM,5%,0.125W	80009	317-0201-00
A34A1R2047	317-0750-00		RES,FXD,CMPSN:75 OHM,5%,0.125W	80009	317-0750-00
A34A1R3031	317-0201-00		RES,FXD,CMPSN:200 OHM,5%,0.125W	80009	317-0201-00
A34A1R3032	317-0242-00		RES,FXD,CMPSN:2.4K OHM,5%,0.125W	80009	317-0242-00
A34A1R3034	317-0103-00		RES,FXD,CMPSN:10K OHM,5%,0.125W	80009	317-0103-00
A34A1R3035	317-0103-00		RES,FXD,CMPSN:10K OHM,5%,0.125W	80009	317-0103-00
A34A1R3041	317-0103-00		RES,FXD,CMPSN:10K OHM,5%,0.125W	80009	317-0103-00
A34A1R3042	317-0103-00		RES,FXD,CMPSN:10K OHM,5%,0.125W	80009	317-0103-00
A34A1R3044	315-0911-00		RES,FXD,FILM:910 OHM,5%,0.25W	80009	315-0911-00
A34A1R3046	317-0220-00		RES,FXD,CMPSN:22 OHM,5%,0.125W	80009	317-0220-00
A34A1U2022	155-0285-00		MICROCKT,DGTL:CALIBRATOR	80009	155-0285-00
A34A1U3031	155-0287-00		MICROCKT,DGTL:DISTRIBUTION AMPLIFIER	80009	155-0287-00
A34A1U3051	155-0286-00		MICROCKT,DGTL:MIXER	80009	155-0286-00
A34A1VR1051	152-0456-00		DIODE,ZENER:;6.2,5%,0.4W;1N827,DO-7	04713	1N827
A34A1Y3038	158-0258-00		XTAL UNIT,QTZ:100MHZ,5PPM,-15 TO +75 DEG	00809	HC-35/U
A34A2	-----		CIRCUIT BD ASSY:100MHZ OSC REGULATOR (PART OF A34)		
A34A2C1015	290-0973-00		CAP,FXD,ELCLTL:100UF,20%,25VDC	24165	513D107M0258B4D
A34A2C1021	290-0973-00		CAP,FXD,ELCLTL:100UF,20%,25VDC	24165	513D107M0258B4D
A34A2L1015	108-1112-00		COIL,RF:FIXED 170UH	80009	108-1112-00
A34A2L1025	108-1112-00		COIL,RF:FIXED 170UH	80009	108-1112-00
A34A2R1015	315-0103-00		RES,FXD,FILM:10K OHM,5%,0.25W	80009	315-0103-00
A34A2R1021	315-0103-00		RES,FXD,FILM:10K OHM,5%,0.25W	80009	315-0103-00

Replaceable Electrical Parts
494A/494AP Service Vol.2

Component No.	Tektronix Part No.	Serial/Assembly No.		Name & Description	Mfr. Code	Mfr. Part No.
		Effective	Discont			
A34A2W1017	175-8737-00			CA ASSY, SP, ELEC:5,26 AWG, 4.0 L, RIBBON	TK1375	175-8737-00
A34A3	119-1905-01			RELAY ASSEMBLY: (OPTION 07 ONLY)	80009	119-1905-01
A34A3C345	281-0825-00			CAP, FXD, CER DI:0.005UF, +100-0%, 100V	33095	51-726-008
A34A3A1	670-8491-01			CIRCUIT BD ASSY:RELAY (OPTION 07 ONLY)	80009	670-8491-01
A34A3A1C1010	283-0220-00			CAP, FXD, CER DI:0.01UF, 20%, 50V	04222	SR205C103MAA
A34A3A1CR1010	152-0141-02			DIODE, SIG: , ULTRA FAST;40V, 150MA, 4NS, 2PF;1N4 152, DO-35, T&R	80009	152-0141-02
A34A3A1CR1012	152-0141-02			DIODE, SIG: , ULTRA FAST;40V, 150MA, 4NS, 2PF;1N4 152, DO-35, T&R	80009	152-0141-02
A34A3A1CR1014	152-0141-02			DIODE, SIG: , ULTRA FAST;40V, 150MA, 4NS, 2PF;1N4 152, DO-35, T&R	80009	152-0141-02
A34A3A1CR1016	152-0141-02			DIODE, SIG: , ULTRA FAST;40V, 150MA, 4NS, 2PF;1N4 152, DO-35, T&R	80009	152-0141-02
A34A3A1CR1018	152-0141-02			DIODE, SIG: , ULTRA FAST;40V, 150MA, 4NS, 2PF;1N4 152, DO-35, T&R	80009	152-0141-02
A34A3A1CR1019	152-0141-02			DIODE, SIG: , ULTRA FAST;40V, 150MA, 4NS, 2PF;1N4 152, DO-35, T&R	80009	152-0141-02
A34A3A1K1010	148-0108-00			RELAY, ARMATURE:2 FORM C, LATCHING, 2-COILS 5V DC 61 OHMS, CONTACTS 28 VDC 1A, PKG T05	11532	720-5
A34A3A1R1010	321-0083-00			RES, FXD, FILM:71.5 OHM, 1%, 0.125W, TC=TO	07716	CEAD71R50F
A34A3A1R1012	321-0090-00			RES, FXD, FILM:84.5 OHM, 1%, 0.125W, TC=TO	80009	321-0090-00
A34A3A1R1014	321-0143-00			RES, FXD, FILM:301 OHM, 1%, 0.125W, TC=TO	07716	CEAD301R0F
A34A3A1R1016	301-0101-00			RES, FXD, FILM:100 OHM, 5%, 0.5W	01121	EB1015
A36	119-1588-02			PH LOCK 3RD LD:	80009	119-1588-02
A36C261	281-0825-00			CAP, FXD, CER DI:0.005UF, +100-0%, 100V	33095	51-726-008
A36C263	281-0825-00			CAP, FXD, CER DI:0.005UF, +100-0%, 100V	33095	51-726-008
A36C265	281-0825-00			CAP, FXD, CER DI:0.005UF, +100-0%, 100V	33095	51-726-008
A36C267	281-0825-00			CAP, FXD, CER DI:0.005UF, +100-0%, 100V	33095	51-726-008
A36U1010	156-0277-00			IC, LINEAR: BIPOLAR, VOLTAGE REGULATOR; POSITIV E, 5.0V, 1.0A, 4%; MC7805CT, TO-220 CKT BOARD ASSY: REFERENCE LOCK	80009	156-0277-00
A36A1	-----					
A36A1C1012	283-0220-00			CAP, FXD, CER DI:0.01UF, 20%, 50V	04222	SR205C103MAA
A36A1C1013	290-0782-00			CAP, FXD, ELCTLT:4.7UF, +75-20%, 35VDC	55680	UVX1V4R7MAA
A36A1C1019	283-0167-00			CAP, FXD, CER DI:0.1UF, 10%, 100V	80009	283-0167-00
A36A1C1021	283-0220-00			CAP, FXD, CER DI:0.01UF, 20%, 50V	04222	SR205C103MAA
A36A1C1023	283-0220-00			CAP, FXD, CER DI:0.01UF, 20%, 50V	04222	SR205C103MAA
A36A1C1026	283-0167-00			CAP, FXD, CER DI:0.1UF, 10%, 100V	80009	283-0167-00
A36A1C1030	283-0220-00			CAP, FXD, CER DI:0.01UF, 20%, 50V	04222	SR205C103MAA
A36A1C1031	283-0486-00			CAP, FXD, CER DI:1.0UF, 10%, 50V	04222	SR305C105KAA
A36A1C1032	283-0167-00			CAP, FXD, CER DI:0.1UF, 10%, 100V	80009	283-0167-00
A36A1C1033	283-0486-00			CAP, FXD, CER DI:1.0UF, 10%, 50V	04222	SR305C105KAA
A36A1C1036	283-0167-00			CAP, FXD, CER DI:0.1UF, 10%, 100V	80009	283-0167-00
A36A1C1037	283-0220-00			CAP, FXD, CER DI:0.01UF, 20%, 50V	04222	SR205C103MAA
A36A1C1038	281-0812-00			CAP, FXD, CER DI:1000PF, 10%, 100V	04222	SA101C102KAA
A36A1C1040	283-0220-00			CAP, FXD, CER DI:0.01UF, 20%, 50V	04222	SR205C103MAA
A36A1C1046	290-0746-00			CAP, FXD, ELCTLT:47UF, +50-20%, 16V	80009	290-0746-00
A36A1C2017	290-0782-00			CAP, FXD, ELCTLT:4.7UF, +75-20%, 35VDC	55680	UVX1V4R7MAA
A36A1C2018	290-0782-00			CAP, FXD, ELCTLT:4.7UF, +75-20%, 35VDC	55680	UVX1V4R7MAA
A36A1C2019	283-0220-00			CAP, FXD, CER DI:0.01UF, 20%, 50V	04222	SR205C103MAA
A36A1C2020	290-0782-00			CAP, FXD, ELCTLT:4.7UF, +75-20%, 35VDC	55680	UVX1V4R7MAA
A36A1C2024	283-0220-00			CAP, FXD, CER DI:0.01UF, 20%, 50V	04222	SR205C103MAA
A36A1C2029	283-0167-00			CAP, FXD, CER DI:0.1UF, 10%, 100V	80009	283-0167-00
A36A1C2038	283-0785-00			CAP, FXD, MICA DI:250PF, 1%, 500V	80009	283-0785-00
A36A1C2039	283-0167-00			CAP, FXD, CER DI:0.1UF, 10%, 100V	80009	283-0167-00
A36A1C2042	283-0220-00			CAP, FXD, CER DI:0.01UF, 20%, 50V	04222	SR205C103MAA

Replaceable Electrical Parts
494A/494AP Service Vol.2

Component No.	Tektronix		Serial/Assembly No.	Name & Description	Mfr. Code	Mfr. Part No.
	Part No.	Effective Dscnt				
A36A1CR1020	152-0141-02			DIODE, SIG:, ULTRA FAST; 40V, 150MA, 4NS, 2PF; 1N4152, DO-35, T&R	80009	152-0141-02
A36A1CR2021	152-0141-02			DIODE, SIG:, ULTRA FAST; 40V, 150MA, 4NS, 2PF; 1N4152, DO-35, T&R	80009	152-0141-02
A36A1CR2022	152-0141-02			DIODE, SIG:, ULTRA FAST; 40V, 150MA, 4NS, 2PF; 1N4152, DO-35, T&R	80009	152-0141-02
A36A1CR2036	152-0141-02			DIODE, SIG:, ULTRA FAST; 40V, 150MA, 4NS, 2PF; 1N4152, DO-35, T&R	80009	152-0141-02
A36A1L2013	108-1202-00			COIL, RF: FXD, TOROIDAL, 4.5UH +22% -37%	TK1345	ORDER BY DESCR
A36A1P1017	131-0608-00			TERMINAL, PIN: 0.365 L X 0.025 BRZ GLD PL	80009	131-0608-00
A36A1P1021	131-0608-00			TERMINAL, PIN: 0.365 L X 0.025 BRZ GLD PL	80009	131-0608-00
A36A1P1025	131-0951-01			CONN, RF JACK:	80009	131-0951-01
A36A1P1026	131-0608-00			TERMINAL, PIN: 0.365 L X 0.025 BRZ GLD PL	80009	131-0608-00
A36A1P2025	131-0951-01			CONN, RF JACK:	80009	131-0951-01
A36A1P2026	131-0951-01			CONN, RF JACK:	80009	131-0951-01
A36A1Q1031	151-0190-00			TRANSISTOR, SIG: BIPOLAR, NPN; 40V, 200MA, 300MHZ, AMPLIFIER; 2N3904, TO-92 EBC	80009	151-0190-00
A36A1Q1033	151-0190-00			TRANSISTOR, SIG: BIPOLAR, NPN; 40V, 200MA, 300MHZ, AMPLIFIER; 2N3904, TO-92 EBC	80009	151-0190-00
A36A1Q2014	151-0424-00			TRANSISTOR, SIG: BIPOLAR, NPN; 15V, 500MA, SWITCH ING; MPS2369A, TO-92 EBC	80009	151-0424-00
A36A1R1011	321-0251-00			RES, FXD, FILM: 4.02K OHM, 1%, 0.125W, TC=TO	80009	321-0251-00
A36A1R1012	321-0314-00			RES, FXD, FILM: 18.2K OHM, 1%, 0.125W, TC=TO	80009	321-0314-00
A36A1R1013	321-0638-00			RES, FXD, FILM: 7.96K OHM, 1%, 0.125W, TC=TO	01121	
A36A1R1014	321-0417-00			RES, FXD, FILM: 215K OHM, 1%, 0.125W, TC=TO	01121	ADVISE
A36A1R1015	317-0103-00			RES, FXD, CMPSN: 10K OHM, 5%, 0.125W	80009	317-0103-00
A36A1R1016	321-0460-00			RES, FXD, FILM: 604K OHM, 1%, 0.125W, TC=TO	07716	CEAD60402F
A36A1R1017	317-0100-00			RES, FXD, CMPSN: 10 OHM, 5%, 0.125W	80009	317-0100-00
A36A1R1018	317-0512-00			RES, FXD, CMPSN: 5.1K OHM, 5%, 0.125	80009	317-0512-00
A36A1R1019	317-0102-00			RES, FXD, CMPSN: 1K OHM, 5%, 0.125W	80009	317-0102-00
A36A1R1021	317-0510-00			RES, FXD, CMPSN: 51 OHM, 5%, 0.125W	80009	317-0510-00
A36A1R1022	317-0104-00			RES, FXD, CMPSN: 100K OHM, 5%, 0.125W	80009	317-0104-00
A36A1R1023	317-0472-00			RES, FXD, CMPSN: 4.7K OHM, 5%, 0.125W	80009	317-0472-00
A36A1R1028	321-0356-00			RES, FXD, FILM: 49.9K OHM, 1%, 0.125W, TC=TO	19701	5033ED49K90F
A36A1R1029	317-0205-00			RES, FXD, CMPSN: 2M OHM, 5%, 0.125W	80009	317-0205-00
A36A1R1033	317-0100-00			RES, FXD, CMPSN: 10 OHM, 5%, 0.125W	80009	317-0100-00
A36A1R1034	317-0154-00			RES, FXD, CMPSN: 150K OHM, 5%, 0.125	80009	317-0154-00
A36A1R1035	317-0154-00			RES, FXD, CMPSN: 150K OHM, 5%, 0.125	80009	317-0154-00
A36A1R1036	317-0100-00			RES, FXD, CMPSN: 10 OHM, 5%, 0.125W	80009	317-0100-00
A36A1R1037	317-0124-00			RES, FXD, CMPSN: 120K OHM, 5%, 0.125W	80009	317-0124-00
A36A1R1038	317-0154-00			RES, FXD, CMPSN: 150K OHM, 5%, 0.125	80009	317-0154-00
A36A1R1039	321-0289-00			RES, FXD, FILM: 10.0K OHM, 1%, 0.125W, TC=TO	57668	FXE10K0
A36A1R1040	317-0154-00			RES, FXD, CMPSN: 150K OHM, 5%, 0.125	80009	317-0154-00
A36A1R1041	317-0103-00			RES, FXD, CMPSN: 10K OHM, 5%, 0.125W	80009	317-0103-00
A36A1R1042	317-0103-00			RES, FXD, CMPSN: 10K OHM, 5%, 0.125W	80009	317-0103-00
A36A1R1044	317-0102-00			RES, FXD, CMPSN: 1K OHM, 5%, 0.125W	80009	317-0102-00
A36A1R1047	317-0102-00			RES, FXD, CMPSN: 1K OHM, 5%, 0.125W	80009	317-0102-00
A36A1R1048	317-0102-00			RES, FXD, CMPSN: 1K OHM, 5%, 0.125W	80009	317-0102-00
A36A1R2015	317-0100-00			RES, FXD, CMPSN: 10 OHM, 5%, 0.125W	80009	317-0100-00
A36A1R2016	317-0681-00			RES, FXD, CMPSN: 680 OHM, 5%, 0.125W	80009	317-0681-00
A36A1R2019	317-0103-00			RES, FXD, CMPSN: 10K OHM, 5%, 0.125W	80009	317-0103-00
A36A1R2021	317-0103-00			RES, FXD, CMPSN: 10K OHM, 5%, 0.125W	80009	317-0103-00
A36A1R2024	317-0511-00			RES, FXD, CMPSN: 510 OHM, 5%, 0.125W	80009	317-0511-00
A36A1R2030	317-0622-00			RES, FXD, CMPSN: 6.2K OHM, 5%, 0.125W	80009	317-0622-00
A36A1R2031	317-0512-00			RES, FXD, CMPSN: 5.1K OHM, 5%, 0.125	80009	317-0512-00
A36A1R2032	317-0222-00			RES, FXD, CMPSN: 2.2K OHM, 5%, 0.125W	80009	317-0222-00
A36A1R2033	317-0512-00			RES, FXD, CMPSN: 5.1K OHM, 5%, 0.125	80009	317-0512-00
A36A1R2035	317-0163-00			RES, FXD, CMPSN: 16K OHM, 5%, 0.125W	80009	317-0163-00

Replaceable Electrical Parts
494A/494AP Service Vol.2

Component No.	Tektronix	Serial/Assembly No.		Name & Description	Mfr.	Mfr. Part No.
	Part No.	Effective	Discont		Code	
A36A1R2039	321-0272-00			RES, FXD, FILM: 6.65K OHM, 1%, 0.125W, TC=TO	80009	321-0272-00
A36A1R2042	311-0609-00			RES, VAR, NONMW: TRMR, 2K OHM, 0.5W	80009	311-0609-00
A36A1R2043	317-0203-00			RES, FXD, CMPSN: 20K OHM, 5%, 0.125W	80009	317-0203-00
A36A1R2045	321-0289-00			RES, FXD, FILM: 10.0K OHM, 1%, 0.125W, TC=TO	57668	FXE10K0
A36A1TP1044	214-0579-00			TERM, TEST POINT: BRS CD PL	TK0858	ORDER BY DESCR
A36A1TP2026	214-0579-00			TERM, TEST POINT: BRS CD PL	TK0858	ORDER BY DESCR
A36A1TP2046	214-0579-00			TERM, TEST POINT: BRS CD PL	TK0858	ORDER BY DESCR
A36A1U1012	156-1225-01			IC, LINEAR: BIPOLAR, COMPARATOR; DUPLICATE OF 156-1225-00, DO NOT USE; LM393N, DIP08.3	80009	156-1225-01
A36A1U1034	156-1156-00			IC, LINEAR: BIFET, OP-AMP; ; LF356N, DIP08.3	80009	156-1156-00
A36A1U1044	156-0388-00			IC, DIGITAL: LSTTL, FLIP FLOP; DUAL D W/SET & CLR; 74LS74, DIP14.3, TUBE	80009	156-0388-00
A36A1U2020	156-1248-00			IC, DIGITAL: ECL, PRESCALER; DIVIDE BY 100; SP8629, DIP08.3	80009	156-1248-00
A36A1U2032	156-0721-02			IC, DIGITAL: LSTTL, GATES; DUPLICATE OF 156-0721-00; 74LS132, DIP14.3, TUBE	80009	156-0721-02
A36A1U2046	156-1335-00			IC, DIGITAL: LSTTL, MULTIVIBRATOR; DUAL RETRIG MONOSTABLE; 96LS02, DIP16.3	80009	156-1335-00
A36A2	670-7917-01			CIRCUIT BD ASSY: REFERENCE LOCK REGULATOR	80009	670-7917-01
A36A2C1010	283-0167-00			CAP, FXD, CER DI: 0.1UF, 10%, 100V	80009	283-0167-00
A36A2C1012	283-0167-00			CAP, FXD, CER DI: 0.1UF, 10%, 100V	80009	283-0167-00
A37	119-1576-01			OSCILLATOR, RF: 10.000MHZ, CRYSTAL	80009	119-1576-01
A37W1026	175-8735-00			CA ASSY, SP, ELEC: 4, 26 AWG, 4.0 L, RIBBON	TK1375	175-8735-00
A38	670-7947-03			CIRCUIT BD ASSY: FRONT PNL	80009	670-7947-03
A38C1016	283-0239-00			CAP, FXD, CER DI: 0.022UF, 10%, 50V	80009	283-0239-00
A38C1047	283-0204-00			CAP, FXD, CER DI: 0.01UF, 20%, 50V	51406	RPE110Z0103M50V
A38C2046	283-0776-00			CAP, FXD, MICA DI: 2130 PF, 1%, 500V	80009	283-0776-00
A38C3030	283-0154-00			CAP, FXD, CER DI: 22PF, 5%, 50V	05397	C315C220J565CA
A38C4028	283-0204-00			CAP, FXD, CER DI: 0.01UF, 20%, 50V	51406	RPE110Z0103M50V
A38C6021	283-0204-00			CAP, FXD, CER DI: 0.01UF, 20%, 50V	51406	RPE110Z0103M50V
A38C6091	283-0204-00			CAP, FXD, CER DI: 0.01UF, 20%, 50V	51406	RPE110Z0103M50V
A38CR1017	152-0141-02			DIODE, SIG: ULTRA FAST; 40V, 150MA, 4NS, 2PF; 1N4152, DO-35, T&R	80009	152-0141-02
A38CR2018	152-0141-02			DIODE, SIG: ULTRA FAST; 40V, 150MA, 4NS, 2PF; 1N4152, DO-35, T&R	80009	152-0141-02
A38CR2043	152-0141-02			DIODE, SIG: ULTRA FAST; 40V, 150MA, 4NS, 2PF; 1N4152, DO-35, T&R	80009	152-0141-02
A38CR3012	152-0322-00			DIODE, SIG: SCHKY.; 15V, 410MV AT 1MA, 1.2PF; 5082-2811, T&R	80009	152-0322-00
A38CR3013	152-0322-00			DIODE, SIG: SCHKY.; 15V, 410MV AT 1MA, 1.2PF; 5082-2811, T&R	80009	152-0322-00
A38CR4017	152-0141-02			DIODE, SIG: ULTRA FAST; 40V, 150MA, 4NS, 2PF; 1N4152, DO-35, T&R	80009	152-0141-02
A38CR4027	152-0141-02			DIODE, SIG: ULTRA FAST; 40V, 150MA, 4NS, 2PF; 1N4152, DO-35, T&R	80009	152-0141-02
A38CR6035	152-0141-02			DIODE, SIG: ULTRA FAST; 40V, 150MA, 4NS, 2PF; 1N4152, DO-35, T&R	80009	152-0141-02
A38CR6090	152-0141-02			DIODE, SIG: ULTRA FAST; 40V, 150MA, 4NS, 2PF; 1N4152, DO-35, T&R	80009	152-0141-02
A38DS1048	150-1068-00			LT EMITTING DIO: RED, 635NM, 10MA MAX	80009	150-1068-00
A38DS1054	150-1068-00			LT EMITTING DIO: RED, 635NM, 10MA MAX	80009	150-1068-00
A38DS1121	150-1068-00			LT EMITTING DIO: RED, 635NM, 10MA MAX	80009	150-1068-00
A38DS2014	150-1068-00			LT EMITTING DIO: RED, 635NM, 10MA MAX	80009	150-1068-00
A38DS2016	150-1031-00			LT EMITTING DIO: RED, 650NM, 40MA MAX	50434	HLMP-1002
A38DS2048	150-1068-00			LT EMITTING DIO: RED, 635NM, 10MA MAX	80009	150-1068-00
A38DS2049	150-1068-00			LT EMITTING DIO: RED, 635NM, 10MA MAX	80009	150-1068-00
A38DS2056	150-1068-00			LT EMITTING DIO: RED, 635NM, 10MA MAX	80009	150-1068-00
A38DS2058	150-1068-00			LT EMITTING DIO: RED, 635NM, 10MA MAX	80009	150-1068-00

Replaceable Electrical Parts
494A/494AP Service Vol.2

Component No.	Tektronix Part No.	Serial/Assembly No. Effective Dscont	Name & Description	Mfr. Code	Mfr. Part No.
A38DS2122	150-1068-00		LT EMITTING DIO:RED,635NM,10MA MAX	80009	150-1068-00
A38DS2123	150-1068-00		LT EMITTING DIO:RED,635NM,10MA MAX	80009	150-1068-00
A38DS3035	150-1068-00		LT EMITTING DIO:RED,635NM,10MA MAX	80009	150-1068-00
A38DS3036	150-1068-00		LT EMITTING DIO:RED,635NM,10MA MAX	80009	150-1068-00
A38DS3037	150-1068-00		LT EMITTING DIO:RED,635NM,10MA MAX	80009	150-1068-00
A38DS3038	150-1068-00		LT EMITTING DIO:RED,635NM,10MA MAX	80009	150-1068-00
A38DS3043	150-1068-00		LT EMITTING DIO:RED,635NM,10MA MAX	80009	150-1068-00
A38DS3044	150-1068-00		LT EMITTING DIO:RED,635NM,10MA MAX	80009	150-1068-00
A38DS3045	150-1068-00		LT EMITTING DIO:RED,635NM,10MA MAX	80009	150-1068-00
A38DS3046	150-1068-00		LT EMITTING DIO:RED,635NM,10MA MAX	80009	150-1068-00
A38DS3047	150-1068-00		LT EMITTING DIO:RED,635NM,10MA MAX	80009	150-1068-00
A38DS3048	150-1068-00		LT EMITTING DIO:RED,635NM,10MA MAX	80009	150-1068-00
A38DS3052	150-1068-00		LT EMITTING DIO:RED,635NM,10MA MAX	80009	150-1068-00
A38DS3053	150-1068-00		LT EMITTING DIO:RED,635NM,10MA MAX	80009	150-1068-00
A38DS3055	150-1068-00		LT EMITTING DIO:RED,635NM,10MA MAX	80009	150-1068-00
A38DS3122	150-1068-00		LT EMITTING DIO:RED,635NM,10MA MAX	80009	150-1068-00
A38DS3123	150-1068-00		LT EMITTING DIO:RED,635NM,10MA MAX	80009	150-1068-00
A38DS4046	150-1068-00		LT EMITTING DIO:RED,635NM,10MA MAX	80009	150-1068-00
A38DS4052	150-1068-00		LT EMITTING DIO:RED,635NM,10MA MAX	80009	150-1068-00
A38DS4122	150-1068-00		LT EMITTING DIO:RED,635NM,10MA MAX	80009	150-1068-00
A38DS4123	150-1068-00		LT EMITTING DIO:RED,635NM,10MA MAX	80009	150-1068-00
A38DS5015	150-1029-00		LT EMITTING DIO:GREEN,565NM,35MA	58361	Q6480/MV5274C
A38DS5050	150-1068-00		LT EMITTING DIO:RED,635NM,10MA MAX	80009	150-1068-00
A38DS5120	150-1068-00		LT EMITTING DIO:RED,635NM,10MA MAX	80009	150-1068-00
A38DS5124	150-1031-00		LT EMITTING DIO:RED,650NM,40MA MAX	50434	HLMP-1002
A38DS6046	150-1033-00		LT EMITTING DIO:AMBER,585NM,40MA MAX	80009	150-1033-00
A38DS6052	150-1068-00		LT EMITTING DIO:RED,635NM,10MA MAX	80009	150-1068-00
A38DS6062	150-1068-00		LT EMITTING DIO:RED,635NM,10MA MAX	80009	150-1068-00
A38L1045	108-0742-00		COIL,RF:FIXED,83UH	80009	108-0742-00
A38R1015	315-0334-00		RES,FXD,FILM:330K OHM,5%,0.25W	80009	315-0334-00
A38R1019	315-0221-00		RES,FXD,FILM:220 OHM,5%,0.25W	80009	315-0221-00
A38R1026	315-0102-00		RES,FXD,FILM:1K OHM,5%,0.25W	80009	315-0102-00
A38R1028	315-0102-00		RES,FXD,FILM:1K OHM,5%,0.25W	80009	315-0102-00
A38R1030	315-0563-00		RES,FXD,FILM:56K OHM,5%,0.25W	80009	315-0563-00
A38R1031	315-0563-00		RES,FXD,FILM:56K OHM,5%,0.25W	80009	315-0563-00
A38R1039	307-0594-00		RES NTWK,FXD,FI:(8)220 OHM,2%,0.125W	80009	307-0594-00
A38R1053	315-0221-00		RES,FXD,FILM:220 OHM,5%,0.25W	80009	315-0221-00
A38R1055	315-0221-00		RES,FXD,FILM:220 OHM,5%,0.25W	80009	315-0221-00
A38R1056	315-0221-00		RES,FXD,FILM:220 OHM,5%,0.25W	80009	315-0221-00
A38R1121	311-2051-00		RES,VAR,NONNW:PNL,10K OHM,20%,0.5W	80009	311-2051-00
A38R2019	315-0103-00		RES,FXD,FILM:10K OHM,5%,0.25W	80009	315-0103-00
A38R2021	315-0221-00		RES,FXD,FILM:220 OHM,5%,0.25W	80009	315-0221-00
A38R2031	315-0103-00		RES,FXD,FILM:10K OHM,5%,0.25W	80009	315-0103-00
A38R2041	307-0696-00		RES NTWK,FXD,FI:7,10K OHM,2%,0.15W EACH	80009	307-0696-00
A38R2044	315-0103-00		RES,FXD,FILM:10K OHM,5%,0.25W	80009	315-0103-00
A38R2045	315-0221-00		RES,FXD,FILM:220 OHM,5%,0.25W	80009	315-0221-00
A38R3119	307-0592-00		RES NTWK,FXD,FI:9,220 OHM,2%,2W	11236	
A38R4043	311-2051-00		RES,VAR,NONNW:PNL,10K OHM,20%,0.5W	80009	311-2051-00
A38R4054	307-0594-00		RES NTWK,FXD,FI:(8)220 OHM,2%,0.125W	80009	307-0594-00
A38R4059	307-0594-00		RES NTWK,FXD,FI:(8)220 OHM,2%,0.125W	80009	307-0594-00
A38R4121	311-2051-00		RES,VAR,NONNW:PNL,10K OHM,20%,0.5W	80009	311-2051-00
A38R5011	315-0202-00		RES,FXD,FILM:2K OHM,5%,0.25W	80009	315-0202-00
A38R5012	315-0221-00		RES,FXD,FILM:220 OHM,5%,0.25W	80009	315-0221-00
A38R6049	311-2049-00		RES,VAR,NONNW:PNL,5K OHM,20%,0.5W	80009	311-2049-00
A38R6051	311-2050-00		RES,VAR,NONNW:PNL,1K OHM,20%,0.5W	80009	311-2050-00
A38R6059	321-0187-00		RES,FXD,FILM:866 OHM,1%,0.125W,TC=TO	07716	CEAD866R0F
A38R6060	315-0221-00		RES,FXD,FILM:220 OHM,5%,0.25W	80009	315-0221-00
A38R6062	311-2054-00		RES,VAR,NONNW:PNL,20K OHM,20%,0.5W	80009	311-2054-00

Replaceable Electrical Parts
494A/494AP Service Vol.2

Component No.	Tektronix Part No.	Serial/Assembly No.		Name & Description	Mfr. Code	Mfr. Part No.
		Effective	Dscont			
A38R6101	321-0250-00			RES,FXD,FILM:3.92K OHM,1%,0.125W,TC=TO	07716	CEAD39200F
A38R6102	321-0198-00			RES,FXD,FILM:1.13K OHM,1%,0.125W,TC=TO	07716	CEAD11300F
A38R6104	311-2052-00			RES,VAR, NONNW: PNL, 20K OHM, 20%, 0.5W	80009	311-2052-00
A38R6106	311-2052-00			RES,VAR, NONNW: PNL, 20K OHM, 20%, 0.5W	80009	311-2052-00
A38S1023	263-0020-02			SWITCH PB ASSY: MOMENTARY	80009	263-0020-02
A38S1048	263-0020-01			SWITCH PB ASSY: MOMENTARY	80009	263-0020-01
A38S1054	263-0020-01			SWITCH PB ASSY: MOMENTARY	80009	263-0020-01
A38S1121	263-0020-01			SWITCH PB ASSY: MOMENTARY	80009	263-0020-01
A38S2014	263-0020-01			SWITCH PB ASSY: MOMENTARY	80009	263-0020-01
A38S2020	263-0020-02			SWITCH PB ASSY: MOMENTARY	80009	263-0020-02
A38S2035	263-0054-02			SWITCH, ROTARY: OPTICAL	80009	263-0054-02
A38S2048	263-0020-01			SWITCH PB ASSY: MOMENTARY	80009	263-0020-01
A38S2049	263-0020-01			SWITCH PB ASSY: MOMENTARY	80009	263-0020-01
A38S2056	263-0020-01			SWITCH PB ASSY: MOMENTARY	80009	263-0020-01
A38S2058	263-0020-01			SWITCH PB ASSY: MOMENTARY	80009	263-0020-01
A38S2122	263-0020-01			SWITCH PB ASSY: MOMENTARY	80009	263-0020-01
A38S2123	263-0020-01			SWITCH PB ASSY: MOMENTARY	80009	263-0020-01
A38S3035	263-0020-01			SWITCH PB ASSY: MOMENTARY	80009	263-0020-01
A38S3036	263-0020-01			SWITCH PB ASSY: MOMENTARY	80009	263-0020-01
A38S3037	263-0020-01			SWITCH PB ASSY: MOMENTARY	80009	263-0020-01
A38S3038	263-0020-01			SWITCH PB ASSY: MOMENTARY	80009	263-0020-01
A38S3043	263-0020-01			SWITCH PB ASSY: MOMENTARY	80009	263-0020-01
A38S3044	263-0020-01			SWITCH PB ASSY: MOMENTARY	80009	263-0020-01
A38S3045	263-0020-01			SWITCH PB ASSY: MOMENTARY	80009	263-0020-01
A38S3046	263-0020-01			SWITCH PB ASSY: MOMENTARY	80009	263-0020-01
A38S3047	263-0020-01			SWITCH PB ASSY: MOMENTARY	80009	263-0020-01
A38S3048	263-0020-01			SWITCH PB ASSY: MOMENTARY	80009	263-0020-01
A38S3052	263-0020-01			SWITCH PB ASSY: MOMENTARY	80009	263-0020-01
A38S3053	263-0020-01			SWITCH PB ASSY: MOMENTARY	80009	263-0020-01
A38S3055	263-0020-01			SWITCH PB ASSY: MOMENTARY	80009	263-0020-01
A38S3122	263-0020-01			SWITCH PB ASSY: MOMENTARY	80009	263-0020-01
A38S3123	263-0020-01			SWITCH PB ASSY: MOMENTARY	80009	263-0020-01
A38S4046	263-0020-01			SWITCH PB ASSY: MOMENTARY	80009	263-0020-01
A38S4052	263-0020-01			SWITCH PB ASSY: MOMENTARY	80009	263-0020-01
A38S4122	263-0020-01			SWITCH PB ASSY: MOMENTARY	80009	263-0020-01
A38S4123	263-0020-01			SWITCH PB ASSY: MOMENTARY	80009	263-0020-01
A38S5050	263-0020-01			SWITCH PB ASSY: MOMENTARY	80009	263-0020-01
A38S5120	263-0020-01			SWITCH PB ASSY: MOMENTARY	80009	263-0020-01
A38S6052	263-0020-01			SWITCH PB ASSY: MOMENTARY	80009	263-0020-01
A38S6062	263-0020-01			SWITCH PB ASSY: MOMENTARY	80009	263-0020-01
A38U1024	156-0876-00			IC, DIGITAL: CMOS, GATE; SCHMITT TRIG, HEX INV; 74C14, DIP14.3, TUBE	27014	MM74C14 J OR N
A38U1049	156-0651-00			IC, DIGITAL: LSTTL, SHIFT REGISTER; 8-BIT SIPO; 74LS164, DIP14.3, TUBE	80009	156-0651-00
A38U2013	156-0388-00			IC, DIGITAL: LSTTL, FLIP FLOP; DUAL D W/SET & C LR; 74LS74, DIP14.3, TUBE	80009	156-0388-00
A38U2020	156-0385-00			IC, DIGITAL: LSTTL, GATES; HEX INV; 74LS04, DIP14.3, TUBE	80009	156-0385-00
A38U3013	156-0388-00			IC, DIGITAL: LSTTL, FLIP FLOP; DUAL D W/SET & C LR; 74LS74, DIP14.3, TUBE	80009	156-0388-00
A38U3039	160-2357-00	B010100	B010502	MICROCKT, DGTL: 8 BIT MICROCOMPUTER	80009	160-2357-00
A38U3039	160-2357-01	B010503		MICROCKT, DGTL: 8 BIT MICROCOMPUTER, PRGM	80009	160-2357-01
A38U4014	156-0722-02			IC, DIGITAL: LSTTL, GATES; DUPLICATE OF 156-0722-00; 74LS12, DIP14.3, TUBE	80009	156-0722-02
A38U4021	156-1432-00			IC, DIGITAL: LSTTL, DEMUX/DECODER; DUAL 2-TO-4, OC; 74LS156, DIP16.3, TUBE	80009	156-1432-00
A38U4030	156-0956-02			IC, DIGITAL: LSTTL, BUFFER/DRIVER; DUPLICATE OF 156-0956-00; 74LS244, DIP20.3, TUBE	80009	156-0956-02

Replaceable Electrical Parts
494A/494AP Service Vol.2

Component No.	Tektronix Part No.	Serial/Assembly No. Effective Dscont	Name & Description	Mfr. Code	Mfr. Part No.
A38U5021	156-1432-00		IC,DIGITAL:LSTTL,DEMUX/DECODER;DUAL 2-TO-4,OC;74LS156,DIP16.3,TUBE	80009	156-1432-00
A38U5045	156-0651-00		IC,DIGITAL:LSTTL,SHIFT REGISTER;8-BIT SIPO;74LS164,DIP14.3,TUBE	80009	156-0651-00
A38U6024	156-0469-00		IC,DIGITAL:LSTTL,DEMUX/DECODER;3-TO-8 DECODER;74LS138,DIP16.3,TUBE	80009	156-0469-00
A38U6028	156-0651-00		IC,DIGITAL:LSTTL,SHIFT REGISTER;8-BIT SIPO;74LS164,DIP14.3,TUBE	80009	156-0651-00
A38U6045	156-0651-00		IC,DIGITAL:LSTTL,SHIFT REGISTER;8-BIT SIPO;74LS164,DIP14.3,TUBE	80009	156-0651-00
A38U6081	156-0651-00		IC,DIGITAL:LSTTL,SHIFT REGISTER;8-BIT SIPO;74LS164,DIP14.3,TUBE	80009	156-0651-00
A38U6090	156-1161-00		IC,LINEAR:BIPOLAR,VOLTAGE REGULATOR;POSITIV E,ADJUSTABLE,1.5A,4%;LM317T,TO-220	04713	LM317T
A38Y3030	158-0185-00		XTAL UNIT,QTZ:6 MHZ,0.015%,PAR	80009	158-0185-00
A40	670-8389-01		CIRCUIT BD ASSY:VIDEO PROCESSOR	80009	670-8389-01
A40C2016	285-1056-00		CAP,FXD,PLASTIC:1UF,2%,50V	14752	650B1A1056
A40C2051	283-0024-00		CAP,FXD,CER DI:0.1UF,+80-20%,50V	05397	C330C10YZ5U1CA
A40C2057	283-0024-00		CAP,FXD,CER DI:0.1UF,+80-20%,50V	05397	C330C10YZ5U1CA
A40C2061	283-0024-00		CAP,FXD,CER DI:0.1UF,+80-20%,50V	05397	C330C10YZ5U1CA
A40C2066	283-0024-00		CAP,FXD,CER DI:0.1UF,+80-20%,50V	05397	C330C10YZ5U1CA
A40C2068	283-0024-00		CAP,FXD,CER DI:0.1UF,+80-20%,50V	05397	C330C10YZ5U1CA
A40C3011	283-0024-00		CAP,FXD,CER DI:0.1UF,+80-20%,50V	05397	C330C10YZ5U1CA
A40C3015	283-0024-00		CAP,FXD,CER DI:0.1UF,+80-20%,50V	05397	C330C10YZ5U1CA
A40C3026	285-0597-00		CAP,FXD,PLASTIC:0.001UF,1%,100V	14752	410B1B102F
A40C3034	283-0024-00		CAP,FXD,CER DI:0.1UF,+80-20%,50V	05397	C330C10YZ5U1CA
A40C3035	283-0024-00		CAP,FXD,CER DI:0.1UF,+80-20%,50V	05397	C330C10YZ5U1CA
A40C3037	283-0024-00		CAP,FXD,CER DI:0.1UF,+80-20%,50V	05397	C330C10YZ5U1CA
A40C3042	290-0755-00		CAP,FXD,ELCTLT:100UF,+50%-20%,10WVDC	54473	ECE-A10V100L
A40C3045	283-0024-00		CAP,FXD,CER DI:0.1UF,+80-20%,50V	05397	C330C10YZ5U1CA
A40C3048	290-0745-00		CAP,FXD,ELCTLT:22UF,+50-20%,25WVDC	80009	290-0745-00
A40C3052	290-0745-00		CAP,FXD,ELCTLT:22UF,+50-20%,25WVDC	80009	290-0745-00
A40C3056	283-0024-00		CAP,FXD,CER DI:0.1UF,+80-20%,50V	05397	C330C10YZ5U1CA
A40C3058	283-0024-00		CAP,FXD,CER DI:0.1UF,+80-20%,50V	05397	C330C10YZ5U1CA
A40C3059	283-0024-00		CAP,FXD,CER DI:0.1UF,+80-20%,50V	05397	C330C10YZ5U1CA
A40C3062	283-0024-00		CAP,FXD,CER DI:0.1UF,+80-20%,50V	05397	C330C10YZ5U1CA
A40C4011	283-0024-00		CAP,FXD,CER DI:0.1UF,+80-20%,50V	05397	C330C10YZ5U1CA
A40C4014	283-0024-00		CAP,FXD,CER DI:0.1UF,+80-20%,50V	05397	C330C10YZ5U1CA
A40CR2051	152-0141-02		DIODE,SIG:,ULTRA FAST;40V,150MA,4NS,2PF;1N4152,DO-35,T&R	80009	152-0141-02
A40CR3045	152-0141-02		DIODE,SIG:,ULTRA FAST;40V,150MA,4NS,2PF;1N4152,DO-35,T&R	80009	152-0141-02
A40CR4016	152-0141-02		DIODE,SIG:,ULTRA FAST;40V,150MA,4NS,2PF;1N4152,DO-35,T&R	80009	152-0141-02
A40CR4060	152-0141-02		DIODE,SIG:,ULTRA FAST;40V,150MA,4NS,2PF;1N4152,DO-35,T&R	80009	152-0141-02
A40L4042	108-0881-00		COIL,RF:FIXED,40.1UH	80009	108-0881-00
A40L4052	108-0881-00		COIL,RF:FIXED,40.1UH	80009	108-0881-00
A40L4053	108-0881-00		COIL,RF:FIXED,40.1UH	80009	108-0881-00
A40Q3038	151-0261-00		TRANSISTOR,SIG:BIPOLAR,PNP;60V,50MA,100MHZ,AMPLIFIER,TWO DIE DUAL;2N3810,TO-77	80009	151-0261-00
A40Q4025	151-0190-00		TRANSISTOR,SIG:BIPOLAR,NPN;40V,200MA,300MHZ,AMPLIFIER;2N3904,TO-92 EBC	80009	151-0190-00
A40Q4060	151-0302-00		TRANSISTOR,SIG:BIPOLAR,NPN;40V,800MA,300MHZ,AMPLIFIER;2N2222A,TO-18	80009	151-0302-00
A40R1012	311-1338-00		RES,VAR,NONW:TRMR,20K OHM,0.75W	02111	43P203T672
A40R1013	311-1319-00		RES,VAR,NONW:TRMR,10K OHM,0.5W	32997	3006P-1-103
A40R1015	311-1319-00		RES,VAR,NONW:TRMR,10K OHM,0.5W	32997	3006P-1-103

Replaceable Electrical Parts
494A/494AP Service Vol.2

Component No.	Tektronix		Serial/Assembly No. Effective Dscont	Name & Description	Mfr. Code	Mfr. Part No.
	Part No.					
A40R1019	311-1319-00			RES, VAR, NONWV: TRMR, 10K OHM, 0.5W	32997	3006P-1-103
A40R1022	311-1319-00			RES, VAR, NONWV: TRMR, 10K OHM, 0.5W	32997	3006P-1-103
A40R1024	311-1319-00			RES, VAR, NONWV: TRMR, 10K OHM, 0.5W	32997	3006P-1-103
A40R1026	311-1319-00			RES, VAR, NONWV: TRMR, 10K OHM, 0.5W	32997	3006P-1-103
A40R1028	311-1319-00			RES, VAR, NONWV: TRMR, 10K OHM, 0.5W	32997	3006P-1-103
A40R1032	311-1319-00			RES, VAR, NONWV: TRMR, 10K OHM, 0.5W	32997	3006P-1-103
A40R1034	311-1319-00			RES, VAR, NONWV: TRMR, 10K OHM, 0.5W	32997	3006P-1-103
A40R1036	311-1319-00			RES, VAR, NONWV: TRMR, 10K OHM, 0.5W	32997	3006P-1-103
A40R1038	311-1319-00			RES, VAR, NONWV: TRMR, 10K OHM, 0.5W	32997	3006P-1-103
A40R1043	311-1319-00			RES, VAR, NONWV: TRMR, 10K OHM, 0.5W	32997	3006P-1-103
A40R1045	311-1319-00			RES, VAR, NONWV: TRMR, 10K OHM, 0.5W	32997	3006P-1-103
A40R1047	311-1319-00			RES, VAR, NONWV: TRMR, 10K OHM, 0.5W	32997	3006P-1-103
A40R1051	311-1319-00			RES, VAR, NONWV: TRMR, 10K OHM, 0.5W	32997	3006P-1-103
A40R1053	311-1319-00			RES, VAR, NONWV: TRMR, 10K OHM, 0.5W	32997	3006P-1-103
A40R1057	311-1319-00			RES, VAR, NONWV: TRMR, 10K OHM, 0.5W	32997	3006P-1-103
A40R1059	311-1319-00			RES, VAR, NONWV: TRMR, 10K OHM, 0.5W	32997	3006P-1-103
A40R1061	311-1319-00			RES, VAR, NONWV: TRMR, 10K OHM, 0.5W	32997	3006P-1-103
A40R1063	321-0171-00			RES, FXD, FILM: 590 OHM, 1%, 0.125W, TC=TO	80009	321-0171-00
A40R1067	321-0360-00			RES, FXD, FILM: 54.9K OHM, 1%, 0.125W, TC=TO	19701	5033ED54K90F
A40R1069	311-1319-00			RES, VAR, NONWV: TRMR, 10K OHM, 0.5W	32997	3006P-1-103
A40R1070	311-1319-00			RES, VAR, NONWV: TRMR, 10K OHM, 0.5W	32997	3006P-1-103
A40R2021	321-0265-00			RES, FXD, FILM: 5.62K OHM, 1%, 0.125W, TC=TO	80009	321-0265-00
A40R2022	321-0361-00			RES, FXD, FILM: 56.2K OHM, 1%, 0.125W, TC=TO	07716	CEAD56201F
A40R2023	321-0452-00			RES, FXD, FILM: 499K OHM, 1%, 0.125W, TC=TO	80009	321-0452-00
A40R2051	321-0231-00			RES, FXD, FILM: 2.49K OHM, 1%, 0.125W, TC=TO	19701	5033ED2K49F
A40R2053	321-0097-00			RES, FXD, FILM: 100 OHM, 1%, 0.125W, TC=TO	91637	CMF551166100ROF
A40R2054	321-0318-00			RES, FXD, FILM: 20.0K OHM, 1%, 0.125W, TC=TO	80009	321-0318-00
A40R2055	321-0289-00			RES, FXD, FILM: 10.0K OHM, 1%, 0.125W, TC=TO	57668	FXE10KO
A40R2056	321-0277-00			RES, FXD, FILM: 7.50K OHM, 1%, 0.125W, TC=TO	2M627	CRA1#CRB14F7.5K
A40R2057	321-0329-00			RES, FXD, FILM: 26.1K OHM, 1%, 0.125W, TC=TO	80009	321-0329-00
A40R2058	321-0260-00			RES, FXD, FILM: 4.99K OHM, 1%, 0.125W, TC=TO	19701	5033ED4K990F
A40R2064	315-0101-00			RES, FXD, FILM: 100 OHM, 5%, 0.25W	80009	315-0101-00
A40R2066	321-0327-00			RES, FXD, FILM: 24.9K OHM, 1%, 0.125W, TC=TO	07716	CEAD24901F
A40R3011	321-0294-00			RES, FXD, FILM: 11.3K OHM, 1%, 0.125W, TC=TO	80009	321-0294-00
A40R3012	321-0308-00			RES, FXD, FILM: 15.8K OHM, 1%, 0.125W, TC=TO	07716	CEAD15801F
A40R3020	321-0239-00			RES, FXD, FILM: 3.01K OHM, 1%, 0.125W, TC=TO	80009	321-0239-00
A40R3023	315-0122-00			RES, FXD, FILM: 1.2K OHM, 5%, 0.25W	80009	315-0122-00
A40R3024	315-0512-00			RES, FXD, FILM: 5.1K OHM, 5%, 0.25W	80009	315-0512-00
A40R3025	315-0512-00			RES, FXD, FILM: 5.1K OHM, 5%, 0.25W	80009	315-0512-00
A40R3028	321-0298-00			RES, FXD, FILM: 12.4K OHM, 1%, 0.125W, TC=TO	07716	CEAD12401F
A40R3030	311-1917-00			RES, VAR, NONWV: TRMR, 5K OHM, 10%, 0.5W	32997	3386C-1-502
A40R3046	321-0318-00			RES, FXD, FILM: 20.0K OHM, 1%, 0.125W, TC=TO	80009	321-0318-00
A40R3053	315-0101-00			RES, FXD, FILM: 100 OHM, 5%, 0.25W	80009	315-0101-00
A40R3058	315-0101-00			RES, FXD, FILM: 100 OHM, 5%, 0.25W	80009	315-0101-00
A40R3059	315-0101-00			RES, FXD, FILM: 100 OHM, 5%, 0.25W	80009	315-0101-00
A40R3064	315-0152-00			RES, FXD, FILM: 1.5K OHM, 5%, 0.25W	80009	315-0152-00
A40R3065	315-0303-00			RES, FXD, FILM: 30K OHM, 5%, 0.25W	80009	315-0303-00
A40R4010	321-0306-00			RES, FXD, FILM: 15.0K OHM, 1%, 0.125W, TC=TO	80009	321-0306-00
A40R4011	321-0289-00			RES, FXD, FILM: 10.0K OHM, 1%, 0.125W, TC=TO	57668	FXE10KO
A40R4012	321-0289-00			RES, FXD, FILM: 10.0K OHM, 1%, 0.125W, TC=TO	57668	FXE10KO
A40R4013	321-0335-00			RES, FXD, FILM: 30.1K OHM, 1%, 0.125W, TC=TO	80009	321-0335-00
A40R4014	321-0335-00			RES, FXD, FILM: 30.1K OHM, 1%, 0.125W, TC=TO	80009	321-0335-00
A40R4015	321-0328-00			RES, FXD, FILM: 25.5K OHM, 1%, 0.125W, TC=TO	80009	321-0328-00
A40R4017	321-0308-00			RES, FXD, FILM: 15.8K OHM, 1%, 0.125W, TC=TO	07716	CEAD15801F
A40R4018	321-0304-00			RES, FXD, FILM: 14.3K OHM, 1%, 0.125W, TC=TO	80009	321-0304-00
A40R4022	315-0162-00			RES, FXD, FILM: 1.6K OHM, 5%, 0.25W	80009	315-0162-00
A40R4023	321-0289-00			RES, FXD, FILM: 10.0K OHM, 1%, 0.125W, TC=TO	57668	FXE10KO
A40R4024	321-0304-00			RES, FXD, FILM: 14.3K OHM, 1%, 0.125W, TC=TO	80009	321-0304-00

Replaceable Electrical Parts
494A/494AP Service Vol.2

Component No.	Tektronix Part No.	Serial/Assembly No. Effective Dscont	Name & Description	Mfr. Code	Mfr. Part No.
A40R4025	315-0104-00		RES, FXD, FILM: 100K OHM, 5%, 0.25W	80009	315-0104-00
A40R4027	321-0260-00		RES, FXD, FILM: 4.99K OHM, 1%, 0.125W, TC=TO	19701	5033ED4K990F
A40R4028	321-0243-00		RES, FXD, FILM: 3.32K OHM, 1%, 0.125W, TC=TO	80009	321-0243-00
A40R4029	321-0289-00		RES, FXD, FILM: 10.0K OHM, 1%, 0.125W, TC=TO	57668	FXE10K0
A40R4046	321-0289-00		RES, FXD, FILM: 10.0K OHM, 1%, 0.125W, TC=TO	57668	FXE10K0
A40R4060	315-0471-00		RES, FXD, FILM: 470 OHM, 5%, 0.25W	80009	315-0471-00
A40R4065	315-0104-00		RES, FXD, FILM: 100K OHM, 5%, 0.25W	80009	315-0104-00
A40R4066	315-0104-00		RES, FXD, FILM: 100K OHM, 5%, 0.25W	80009	315-0104-00
A40R4067	315-0104-00		RES, FXD, FILM: 100K OHM, 5%, 0.25W	80009	315-0104-00
A40R4068	315-0241-00		RES, FXD, FILM: 240 OHM, 5%, 0.25W	80009	315-0241-00
A40U2015	156-1211-00		IC, MISC: BIFET, ANALOG SWITCH; QUAD; LF13333, DIP16.3	80009	156-1211-00
A40U2039	155-0106-00		MICROCKT, DGTL: NORMAL CKT	80009	155-0106-00
A40U2055	156-0158-00		IC, LINEAR: BIPOLAR, OP-AMP; DUAL; MC1458P1, DIP08.3	80009	156-0158-00
A40U2066	156-0770-00		IC, LINEAR: BIFET, OP-AMP; ; LF356, TO-99	27014	LF356H
A40U3015	156-0570-00		IC, LINEAR: BIPOLAR, COMPARATOR; DUAL, OPEN COLLECTOR, 80NS; LM319H, TO-100	TK1468	LM319H
A40U3025	156-1211-00		IC, MISC: BIFET, ANALOG SWITCH; QUAD; LF13333, DIP16.3	80009	156-1211-00
A40U3035	156-0913-00		IC, DIGITAL: LSTTL, FLIP FLOP; OCTAL D-TYPE, ENABLE; 74LS377, DIP20.3, TUBE	80009	156-0913-00
A40U3040	156-0469-00		IC, DIGITAL: LSTTL, DEMUX/DECODER; 3-TO-8 DECODER; 74LS138, DIP16.3, TUBE	80009	156-0469-00
A40U3045	156-0158-00		IC, LINEAR: BIPOLAR, OP-AMP; DUAL; MC1458P1, DIP08.3	80009	156-0158-00
A40U3062	156-0770-00		IC, LINEAR: BIFET, OP-AMP; ; LF356, TO-99	27014	LF356H
A40U3063	156-1211-00		IC, MISC: BIFET, ANALOG SWITCH; QUAD; LF13333, DIP16.3	80009	156-1211-00
A40VR3011	152-0662-00		DIODE, ZENER: ; 5V, 1%, 0.4W; 1N751 FMLY, DO-7 OR 35, TR	04713	SZG195RL
A40VR4011	152-0662-00		DIODE, ZENER: ; 5V, 1%, 0.4W; 1N751 FMLY, DO-7 OR 35, TR	04713	SZG195RL
A40VR4028	152-0195-00		DIODE, ZENER: ; 5.1V, 5%, 0.4W; 1N751A FMLY, DO-35 OR 7	80009	152-0195-00
A40W3026	131-0566-00		BUS, CONDUCTOR: DUMMY RES, 0.094 OD X 0.225 L	80009	131-0566-00
A42	672-0166-01		CIRCUIT BD ASSY: PRESELECTOR DRIVER	80009	672-0166-01
A42Q565	151-0426-00		TRANSISTOR, PWR: BIPOLAR, NPN; 80V, 10A, 50MHZ, AMPLIFIER; D44H11, TO-220	80009	151-0426-00
A42A1	670-5552-05		CIRCUIT BD ASSY: PRESELECTOR DRIVER	80009	670-5552-05
A42A1C2026	283-0070-00		CAP, FXD, CER DI: 30PF, 10%, 50V	51642	200-050-NPO-300K
A42A1C2045	283-0070-00		CAP, FXD, CER DI: 30PF, 10%, 50V	51642	200-050-NPO-300K
A42A1C2065	283-0330-00		CAP, FXD, CER DI: 100PF, 5%, 50V	80009	283-0330-00
A42A1C3021	283-0190-00		CAP, FXD, CER DI: 0.47UF, 5%, 50V	04222	SR305C474JAA
A42A1C3028	283-0111-00		CAP, FXD, CER DI: 0.1UF, 20%, 50V	80009	283-0111-00
A42A1C3043	283-0004-00		CAP, FXD, CER DI: 0.02UF, +80-20%, 150V	80009	283-0004-00
A42A1C3048	283-0051-00		CAP, FXD, CER DI: 0.0033UF, 5%, 100V	80009	283-0051-00
A42A1C3052	283-0070-00		CAP, FXD, CER DI: 30PF, 10%, 50V	51642	200-050-NPO-300K
A42A1C3061	283-0111-00		CAP, FXD, CER DI: 0.1UF, 20%, 50V	80009	283-0111-00
A42A1C4038	283-0111-00		CAP, FXD, CER DI: 0.1UF, 20%, 50V	80009	283-0111-00
A42A1C4041	290-0718-00		CAP, FXD, ELCTLT: 22UF, 20%, 35V	80009	290-0718-00
A42A1C4044	290-0718-00		CAP, FXD, ELCTLT: 22UF, 20%, 35V	80009	290-0718-00
A42A1C4061	290-0158-00		CAP, FXD, ELCTLT: 50UF, +75-15%, 25V	26769	40LW5068025U1A
A42A1C4071	290-0209-00		CAP, FXD, ELCTLT: 50UF, +75-10%, 25V	80009	290-0209-00
A42A1C5026	283-0111-00		CAP, FXD, CER DI: 0.1UF, 20%, 50V	80009	283-0111-00
A42A1C5041	290-0718-00		CAP, FXD, ELCTLT: 22UF, 20%, 35V	80009	290-0718-00
A42A1C5046	290-0718-00		CAP, FXD, ELCTLT: 22UF, 20%, 35V	80009	290-0718-00
A42A1C5051	290-0755-00		CAP, FXD, ELCTLT: 100UF, +50%-20%, 10WDC	54473	ECE-A10V100L

Replaceable Electrical Parts
494A/494AP Service Vol.2

Component No.	Tektronix Part No.	Serial/Assembly No. Effective Dscont	Name & Description	Mfr. Code	Mfr. Part No.
A42A1C5061	283-0111-00		CAP,FXD,CER DI:0.1UF,20%,50V	80009	283-0111-00
A42A1CR1020	152-0141-02		DIODE,SIG:,ULTRA FAST;40V,150MA,4NS,2PF;1N4152,DO-35,T&R	80009	152-0141-02
A42A1CR1021	152-0141-02		DIODE,SIG:,ULTRA FAST;40V,150MA,4NS,2PF;1N4152,DO-35,T&R	80009	152-0141-02
A42A1CR2065	152-0322-00		DIODE,SIG:SCHTKY,;15V,410MVF AT 1MA,1.2PF;5082-2811,T&R	80009	152-0322-00
A42A1CR2077	152-0322-00		DIODE,SIG:SCHTKY,;15V,410MVF AT 1MA,1.2PF;5082-2811,T&R	80009	152-0322-00
A42A1CR2078	152-0322-00		DIODE,SIG:SCHTKY,;15V,410MVF AT 1MA,1.2PF;5082-2811,T&R	80009	152-0322-00
A42A1CR3061	152-0322-00		DIODE,SIG:SCHTKY,;15V,410MVF AT 1MA,1.2PF;5082-2811,T&R	80009	152-0322-00
A42A1CR3073	152-0353-00		SEMICONDCAP,DV:RECT,SI,800V,1W	05828	GP10K-014
A42A1CR4012	152-0141-02		DIODE,SIG:,ULTRA FAST;40V,150MA,4NS,2PF;1N4152,DO-35,T&R	80009	152-0141-02
A42A1CR4013	152-0141-02		DIODE,SIG:,ULTRA FAST;40V,150MA,4NS,2PF;1N4152,DO-35,T&R	80009	152-0141-02
A42A1CR4032	152-0322-00		DIODE,SIG:SCHTKY,;15V,410MVF AT 1MA,1.2PF;5082-2811,T&R	80009	152-0322-00
A42A1CR4061	152-0333-00		SEMICONDCAP,DV:SW,SI.55V,200MA,DO-35	07263	FDH-6012
A42A1L4056	108-0881-00		COIL,RF:FIXED,40.1UH	80009	108-0881-00
A42A1L5051	108-0881-00		COIL,RF:FIXED,40.1UH	80009	108-0881-00
A42A1Q1011	151-0301-00		TRANSISTOR,SIG:BIPOLAR,PNP;60V,600MA,200MHZ,AMPLIFIER;2N2907A,TO-18	80009	151-0301-00
A42A1Q1022	151-1022-00		TRANSISTOR,SIG:JFET,N-CH;4V,75MA,80 OHM,SELECTED FOR VGS(OFF);2N4392 FAMILY,TO-18	80009	151-1022-00
A42A1Q1024	151-1022-00		TRANSISTOR,SIG:JFET,N-CH;4V,75MA,80 OHM,SELECTED FOR VGS(OFF);2N4392 FAMILY,TO-18	80009	151-1022-00
A42A1Q2034	151-1022-00		TRANSISTOR,SIG:JFET,N-CH;4V,75MA,80 OHM,SELECTED FOR VGS(OFF);2N4392 FAMILY,TO-18	80009	151-1022-00
A42A1Q2036	151-1022-00		TRANSISTOR,SIG:JFET,N-CH;4V,75MA,80 OHM,SELECTED FOR VGS(OFF);2N4392 FAMILY,TO-18	80009	151-1022-00
A42A1Q2074	151-1022-00		TRANSISTOR,SIG:JFET,N-CH;4V,75MA,80 OHM,SELECTED FOR VGS(OFF);2N4392 FAMILY,TO-18	80009	151-1022-00
A42A1Q3025	151-0290-00		TRANSISTOR,SIG:BIPOLAR,NPN;60V,5.0A,50 MHZ,AMPLIFIER;2N4896,TO-39	80009	151-0290-00
A42A1Q3061	151-1045-00		TRANSISTOR,SIG:JFET,P-CH;4.5V(SELECTED),5MA,1MS,GENERAL;2N5460_SPECIAL,TO-92	80009	151-1045-00
A42A1Q3077	151-1066-00		TRANSISTOR,SIG:JFET,P-CH;10V,10MA(MIN),75 OHM;P1086_FAMILY,TO-92	80009	151-1066-00
A42A1Q4025	151-0134-00		TRANSISTOR,SIG:BIPOLAR,PNP;60V,600MA,200MHZ,AMPLIFIER;2N2905A,TO-39	80009	151-0134-00
A42A1Q4037	151-0301-00		TRANSISTOR,SIG:BIPOLAR,PNP;60V,600MA,200MHZ,AMPLIFIER;2N2907A,TO-18	80009	151-0301-00
A42A1Q5052	151-0429-00		TRANSISTOR,PWR:BIPOLAR,PNP;60V,4.0A,1.0MHZ,AMPLIFIER,DARLINGTON;MJE700,TO-126	80009	151-0429-00
A42A1R1013	315-0273-00		RES,FXD,FILM:27K OHM,5%,0.25W	80009	315-0273-00
A42A1R1017	321-0363-00		RES,FXD,FILM:59.0K OHM,1%,0.125W,TC=TO	07716	CEAD59001F
A42A1R1018	321-0376-00		RES,FXD,FILM:80.6K OHM,1%,0.125W,TC=TO	80009	321-0376-00
A42A1R1019	315-0105-00		RES,FXD,FILM:1M OHM,5%,0.25W	80009	315-0105-00
A42A1R1021	321-1654-07		RES,FXD,FILM:651K OHM,0.1%,0.125W,TC=T9	80009	321-1654-07
A42A1R1022	325-0322-00		RES,FXD,FILM:26.35K OHM,0.1%,0.3W	07088	K747 26.35 KOHM
A42A1R1023	325-0321-00		RES,FXD,FILM:50.87K OHM,0.05%,0.3W	07088	K747 50.87 KOHM
A42A1R1024	325-0320-00		RES,FXD,FILM:7.532K OHM,0.05%,0.3W	07088	K747 7.532 KOHM
A42A1R1025	321-0450-01		RES,FXD,FILM:475K OHM,0.5%,0.125W,TC=TO MI	2M627	CRA180X475KOHM
A42A1R1026	325-0317-00		RES,FXD,FILM:84.9K OHM,0.1%,0.3W	07088	K747 84.9 KOHM
A42A1R1027	315-0105-00		RES,FXD,FILM:1M OHM,5%,0.25W	80009	315-0105-00

Replaceable Electrical Parts
494A/494AP Service Vol.2

Component No.	Tektronix Part No.	Serial/Assembly No. Effective Dscnt	Name & Description	Mfr. Code	Mfr. Part No.
A42A1R1031	311-1319-00		RES, VAR, NONNW: TRMR, 10K OHM, 0.5W	32997	3006P-1-103
A42A1R1032	325-0319-00		RES, FXD, FILM: 100K OHM, 0.1%, 0.3W	07088	K747 100.0 KOHM
A42A1R1033	321-0414-00		RES, FXD, FILM: 200K OHM, 1%, 0.125W, TC=TO	07716	CEAD20002F
A42A1R1034	315-0105-00		RES, FXD, FILM: 1M OHM, 5%, 0.25W	80009	315-0105-00
A42A1R1035	321-0510-00		RES, FXD, FILM: 2.00M OHM, 1%, 0.125W, TC=TO	07716	CEAD20003F
A42A1R1036	321-1653-04		RES, FXD, FILM: 2.25M OHM, 0.1%, 0.125W, TC=T2	80009	321-1653-04
A42A1R1037	321-0405-00		RES, FXD, FILM: 162K OHM, 1%, 0.125W, TC=TO	07716	CEAD16202F
A42A1R1045	311-1319-00		RES, VAR, NONNW: TRMR, 10K OHM, 0.5W	32997	3006P-1-103
A42A1R1049	311-1319-00		RES, VAR, NONNW: TRMR, 10K OHM, 0.5W	32997	3006P-1-103
A42A1R1052	311-1337-00		RES, VAR, NONNW: TRMR, 25K OHM, 0.5W	32997	3006P-1-253
A42A1R1054	311-1337-00		RES, VAR, NONNW: TRMR, 25K OHM, 0.5W	32997	3006P-1-253
A42A1R1056	311-1337-00		RES, VAR, NONNW: TRMR, 25K OHM, 0.5W	32997	3006P-1-253
A42A1R1061	311-1319-00		RES, VAR, NONNW: TRMR, 10K OHM, 0.5W	32997	3006P-1-103
A42A1R1063	311-1337-00		RES, VAR, NONNW: TRMR, 25K OHM, 0.5W	32997	3006P-1-253
A42A1R1064	311-1337-00		RES, VAR, NONNW: TRMR, 25K OHM, 0.5W	32997	3006P-1-253
A42A1R1065	311-1337-00		RES, VAR, NONNW: TRMR, 25K OHM, 0.5W	32997	3006P-1-253
A42A1R1073	325-0318-00		RES, FXD, FILM: 95.7K OHM, 0.5%, 0.3W	07088	K747 95.7 KOHM
A42A1R1074	321-1652-04		RES, FXD, FILM: 375K OHM, 0.1%, 0.125W, TC=T2	80009	321-1652-04
A42A1R1075	325-0325-00		RES, FXD, FILM: 35.97K OHM, 0.1%, 0.3W	07088	K747 35.97 KOHM
A42A1R1076	325-0328-00		RES, FXD, FILM: 141K OHM, 1%, 0.5W	18612	A104D 141KOHM 1%
A42A1R2012	315-0473-00		RES, FXD, FILM: 47K OHM, 5%, 0.25W	80009	315-0473-00
A42A1R2013	315-0473-00		RES, FXD, FILM: 47K OHM, 5%, 0.25W	80009	315-0473-00
A42A1R2014	321-0289-00		RES, FXD, FILM: 10.0K OHM, 1%, 0.125W, TC=TO	57668	FXE10K0
A42A1R2015	321-0771-01		RES, FXD, FILM: 50 OHM, 0.5%, 0.125W, TC=TO	80009	321-0771-01
A42A1R2021	325-0324-00		RES, FXD, FILM: 50K OHM, 0.1%, 0.3W	07088	K747 50.00 KOHM
A42A1R2022	315-0105-00		RES, FXD, FILM: 1M OHM, 5%, 0.25W	80009	315-0105-00
A42A1R2027	321-0319-00		RES, FXD, FILM: 50.5K OHM, 1%, 0.125W, TC=TO	80009	321-0319-00
A42A1R2036	321-0347-00		RES, FXD, FILM: 40.2K OHM, 1%, 0.125W, TC=TO	80009	321-0347-00
A42A1R2062	321-0753-06		RES, FXD, FILM: 9K OHM, 0.25%, 0.125W, TC=T9	07716	CEAE90000C
A42A1R2063	321-0753-06		RES, FXD, FILM: 9K OHM, 0.25%, 0.125W, TC=T9	07716	CEAE90000C
A42A1R2064	315-0105-00		RES, FXD, FILM: 1M OHM, 5%, 0.25W	80009	315-0105-00
A42A1R2066	311-1264-00		RES, VAR, NONNW: TRMR, 1.5K OHM, 0.5W	80009	311-1264-00
A42A1R2069	321-0441-00		RES, FXD, FILM: 383K OHM, 1%, 0.125W, TC=TO	80009	321-0441-00
A42A1R2072	321-0449-00		RES, FXD, FILM: 464K OHM, 1%, 0.125W, TC=TO	80009	321-0449-00
A42A1R2073	321-0891-00		RES, FXD, FILM: 800K OHM, 1%, 0.125W, TC=TO	80009	321-0891-00
A42A1R2074	321-0415-00		RES, FXD, FILM: 205K OHM, 1%, 0.125W, TC=TO	80009	321-0415-00
A42A1R2075	321-0995-00		RES, FXD, FILM: 549K OHM, 1%, 0.125W, TC=TO	01121	
A42A1R2077	321-0432-00		RES, FXD, FILM: 309K OHM, 1%, 0.125W, TC=TO	07716	CEAD30902F
A42A1R2078	321-0441-00		RES, FXD, FILM: 383K OHM, 1%, 0.125W, TC=TO	80009	321-0441-00
A42A1R3011	315-0103-00		RES, FXD, FILM: 10K OHM, 5%, 0.25W	80009	315-0103-00
A42A1R3012	315-0102-00		RES, FXD, FILM: 1K OHM, 5%, 0.25W	80009	315-0102-00
A42A1R3013	315-0102-00		RES, FXD, FILM: 1K OHM, 5%, 0.25W	80009	315-0102-00
A42A1R3014	321-0460-00		RES, FXD, FILM: 604K OHM, 1%, 0.125W, TC=TO	07716	CEAD60402F
A42A1R3021	321-0356-00		RES, FXD, FILM: 49.9K OHM, 1%, 0.125W, TC=TO	19701	5033ED49K90F
A42A1R3028	315-0101-00		RES, FXD, FILM: 100 OHM, 5%, 0.25W	80009	315-0101-00
A42A1R3041	325-0316-00		RES, FXD, FILM: 57.55K OHM, 0.1%, 0.3W	07088	K747 57.55 KOHM
A42A1R3042	315-0102-00		RES, FXD, FILM: 1K OHM, 5%, 0.25W	80009	315-0102-00
A42A1R3043	315-0202-00		RES, FXD, FILM: 2K OHM, 5%, 0.25W	80009	315-0202-00
A42A1R3044	321-0434-00		RES, FXD, FILM: 324K OHM, 1%, 0.125W, TC=TO	07716	CEAD32402F
A42A1R3045	321-0891-00		RES, FXD, FILM: 800K OHM, 1%, 0.125W, TC=TO	80009	321-0891-00
A42A1R3046	325-0319-00		RES, FXD, FILM: 100K OHM, 0.1%, 0.3W	07088	K747 100.0 KOHM
A42A1R3047	315-0102-00		RES, FXD, FILM: 1K OHM, 5%, 0.25W	80009	315-0102-00
A42A1R3052	325-0315-00		RES, FXD, FILM: 20K OHM, 0.05%, 0.3W	07088	K747 20KOHM .05%
A42A1R3053	325-0315-00		RES, FXD, FILM: 20K OHM, 0.05%, 0.3W	07088	K747 20KOHM .05%
A42A1R3054	321-0320-00		RES, FXD, FILM: 21.0K OHM, 1%, 0.125W, TC=TO	80009	321-0320-00
A42A1R3055	321-0284-00		RES, FXD, FILM: 8.87K OHM, 1%, 0.125W, TC=TO	80009	321-0284-00
A42A1R3056	321-0357-03		RES, FXD, FILM: 51.1K OHM, 0.25%, 0.125W, TC=T2	07716	CEAC51101C
A42A1R3061	321-0451-00		RES, FXD, FILM: 487K OHM, 1%, 0.125W, TC=TO	80009	321-0451-00

Replaceable Electrical Parts
494A/494AP Service Vol.2

Component No.	Tektronix Part No.	Serial/Assembly No. Effective Dscont	Name & Description	Mfr. Code	Mfr. Part No.
A42A1R3072	315-0222-00		RES, FXD, FILM: 2.2K OHM, 5%, 0.25W	80009	315-0222-00
A42A1R4011	315-0103-00		RES, FXD, FILM: 10K OHM, 5%, 0.25W	80009	315-0103-00
A42A1R4013	321-0440-00		RES, FXD, FILM: 374K OHM, 1%, 0.125W, TC=TO	07716	CEAD37402F
A42A1R4014	321-0642-00		RES, FXD, FILM: 20.3K OHM, 0.25%, 0.125W, T=T9	80009	321-0642-00
A42A1R4016	315-0113-00		RES, FXD, FILM: 11K OHM, 5%, 0.25W	80009	315-0113-00
A42A1R4030	315-0202-00		RES, FXD, FILM: 2K OHM, 5%, 0.25W	80009	315-0202-00
A42A1R4031	315-0104-00		RES, FXD, FILM: 100K OHM, 5%, 0.25W	80009	315-0104-00
A42A1R4032	315-0273-00		RES, FXD, FILM: 27K OHM, 5%, 0.25W	80009	315-0273-00
A42A1R4040	315-0473-00		RES, FXD, FILM: 10K OHM, 5%, 0.25W	80009	315-0473-00
A42A1R4041	315-0470-00		RES, FXD, FILM: 47 OHM, 5%, 0.25W	80009	315-0470-00
A42A1R4042	315-0470-00		RES, FXD, FILM: 47 OHM, 5%, 0.25W	80009	315-0470-00
A42A1R4043	315-0470-00		RES, FXD, FILM: 47 OHM, 5%, 0.25W	80009	315-0470-00
A42A1R4044	315-0470-00		RES, FXD, FILM: 47 OHM, 5%, 0.25W	80009	315-0470-00
A42A1R4048	315-0105-00		RES, FXD, FILM: 1M OHM, 5%, 0.25W	80009	315-0105-00
A42A1R4049	310-0705-00		RES, FXD, WW: 3 OHM 0.25%, 2W, TC=5PPM/DEG C	80009	310-0705-00
A42A1R4051	321-0238-00		RES, FXD, FILM: 2.94K OHM, 1%, 0.125W, TC=TO	07716	CEAD29400F
A42A1R4052	321-0258-00		RES, FXD, FILM: 4.75K OHM, 1%, 0.125W, TC=TO	80009	321-0258-00
A42A1R4054	315-0102-00		RES, FXD, FILM: 1K OHM, 5%, 0.25W	80009	315-0102-00
A42A1R4063	315-0512-00		RES, FXD, FILM: 5.1K OHM, 5%, 0.25W	80009	315-0512-00
A42A1R4064	315-0101-00		RES, FXD, FILM: 100 OHM, 5%, 0.25W	80009	315-0101-00
A42A1R5015	315-0242-00		RES, FXD, FILM: 2.4K OHM, 5%, 0.25W	80009	315-0242-00
A42A1R5064	315-0103-00		RES, FXD, FILM: 10K OHM, 5%, 0.25W	80009	315-0103-00
A42A1R5065	315-0755-00		RES, FXD, FILM: 7.5M OHM, 5%, 0.25W	80009	315-0755-00
A42A1R5066	315-0475-00		RES, FXD, FILM: 4.7M OHM, 5%, 0.25W	01121	CB4755
A42A1U1011	156-0158-00		IC, LINEAR: BIPOLAR, OP-AMP; DUAL; MC1458P1, DIP08.3	80009	156-0158-00
A42A1U1067	156-0937-00		IC, LINEAR: BIPOLAR, VOLTAGE REFERENCE; POSITIV E, 2.5V, 0.4%, 25PPM, SERIES; AD580LH, TO-52	24355	AD580LH
A42A1U2028	156-0512-00		IC, LINEAR: BIPOLAR, OP-AMP; LOW INPUT BIAS CURRENT, UNCOMPENSATED; LM308N, DIP08.3	80009	156-0512-00
A42A1U2045	156-0512-00		IC, LINEAR: BIPOLAR, OP-AMP; LOW INPUT BIAS CURRENT, UNCOMPENSATED; LM308N, DIP08.3	80009	156-0512-00
A42A1U2047	156-0512-00		IC, LINEAR: BIPOLAR, OP-AMP; LOW INPUT BIAS CURRENT, UNCOMPENSATED; LM308N, DIP08.3	80009	156-0512-00
A42A1U2054	156-0420-00		IC, LINEAR: BIPOLAR, OP-AMP; DIFFERENTIAL PREAMPLIFIER; LM321H, TO-99	27014	LM321H
A42A1U3054	156-0512-00		IC, LINEAR: BIPOLAR, OP-AMP; LOW INPUT BIAS CURRENT, UNCOMPENSATED; LM308N, DIP08.3	80009	156-0512-00
A42A1U4061	156-0385-00		IC, DIGITAL: LSTTL, GATES; HEX INV; 74LS04, DIP14	80009	156-0385-00
A42A1U5022	156-0411-00		IC, LINEAR: BIPOLAR, COMPARATOR; QUAD, SINGLE SUPPLY, 300NS; LM339N, DIP14.3	80009	156-0411-00
A42A1U5031	156-0913-00		IC, DIGITAL: LSTTL, FLIP FLOP; OCTAL D-TYPE, ENABLE; 74LS377, DIP20.3, TUBE	80009	156-0913-00
A42A1U5036	156-0469-00		IC, DIGITAL: LSTTL, DEMUX/DECODER; 3-TO-8 DECODER; 74LS138, DIP16.3, TUBE	80009	156-0469-00
A42A1VR3011	152-0265-00		DIODE, ZENER: .; 24V, 5%, 0.4W; 1N970B, DO-7 OR 35, TR	80009	152-0265-00
A42A1VR3012	152-0281-00		DIODE, ZENER: 22V, 5%, 0.4W; 1N969B, DO-35, OR 7, TR	80009	152-0281-00
A42A1VR3061	152-0514-00		DIODE, ZENER: .; 10V, 1%, 0.4W; 1N961D FMLY, DO-7 OR 35, TR	80009	152-0514-00
A42A1VR3074	152-0120-00		DIODE, ZENER: .; 10V, 5%, 1W; 1N3020B, DO-13	80009	152-0120-00
A42A1W3048	131-0566-00		BUS CONDUCTOR: DUMMY RES, 0.094 OD X 0.225 L	80009	131-0566-00
A44	672-0158-00		CIRCUIT BOARD ASSY: 1ST LO DRIVER	80009	672-0158-00
A44Q352	151-0415-00		TRANSISTOR: NPN, SI, TO-127	04713	SJE419
A44A1	670-9051-00		CIRCUIT BOARD ASSY: 1ST LO DRIVER	80009	670-9051-00
A44A1C1011	283-0203-00		CAP, FXD, CER DI: 0.47UF, 20%, 50V	80009	283-0203-00

Replaceable Electrical Parts
494A/494AP Service Vol.2

Component No.	Tektronix Part No.	Serial/Assembly No. Effective Discnt	Name & Description	Mfr. Code	Mfr. Part No.
A44A1C1018	283-0203-00		CAP, FXD, CER DI: 0.47UF, 20%, 50V	80009	283-0203-00
A44A1C1020	283-0326-00		CAP, FXD, CER DI: 0.082UF, 10%, 50V	04222	SR205C823KAA
A44A1C1029	283-0326-00		CAP, FXD, CER DI: 0.082UF, 10%, 50V	04222	SR205C823KAA
A44A1C2011	290-0804-00		CAP, FXD, ELCTLT: 10UF, +50-20%, 25V	80009	290-0804-00
A44A1C2017	283-0326-00		CAP, FXD, CER DI: 0.082UF, 10%, 50V	04222	SR205C823KAA
A44A1C2018	283-0330-00		CAP, FXD, CER DI: 100PF, 5%, 50V	80009	283-0330-00
A44A1C2019	290-0804-00		CAP, FXD, ELCTLT: 10UF, +50-20%, 25V	80009	290-0804-00
A44A1C2021	283-0176-00		CAP, FXD, CER DI: 0.0022UF, 20%, 50V	04222	SR155C222MAA
A44A1C2022	283-0326-00		CAP, FXD, CER DI: 0.082UF, 10%, 50V	04222	SR205C823KAA
A44A1C2025	290-0301-00		CAP, FXD, ELCTLT: 10UF, 10%, 20V	05397	T110B106K020AS
A44A1C2026	283-0326-00		CAP, FXD, CER DI: 0.082UF, 10%, 50V	04222	SR205C823KAA
A44A1C2032	283-0060-00		CAP, FXD, CER DI: 100PF, 5%, 200V	80009	283-0060-00
A44A1C2042	283-0065-00		CAP, FXD, CER DI: 0.001UF, 5%, 50V	80009	283-0065-00
A44A1C2043	283-0213-00		CAP, FXD, CER DI: 300PF, 5%, 100V	80009	283-0213-00
A44A1C2044	283-0198-00		CAP, FXD, CER DI: 0.22UF, 20%, 50V	05397	C330C224M5U1CA
A44A1C2045	283-0005-00		CAP, FXD, CER DI: 0.01UF, +100-0%, 250V	04222	SR30VE103ZAA
A44A1C2046	283-0060-00		CAP, FXD, CER DI: 100PF, 5%, 200V	80009	283-0060-00
A44A1C2048	283-0212-00		CAP, FXD, CER DI: 2UF, 20%, 50V	05397	C340C205M5U1CA
A44A1C2050	283-0195-00		CAP, FXD, CER DI: 680PF, 5%, 50V	05397	C320C681J1G5CA
A44A1C2051	283-0005-00		CAP, FXD, CER DI: 0.01UF, +100-0%, 250V	04222	SR30VE103ZAA
A44A1C2054	283-0060-00		CAP, FXD, CER DI: 100PF, 5%, 200V	80009	283-0060-00
A44A1C2056	290-0302-00		CAP, FXD, ELCTLT: 100UF, 10%, 20V	05397	T110D107K020MS
A44A1C3013	283-0326-00		CAP, FXD, CER DI: 0.082UF, 10%, 50V	04222	SR205C823KAA
A44A1C3019	283-0111-00		CAP, FXD, CER DI: 0.1UF, 20%, 50V	80009	283-0111-00
A44A1C3020	283-0175-00		CAP, FXD, CER DI: 10PF, 5%, 200V	05397	C312C100D2G5CA 8
A44A1C3027	283-0326-00		CAP, FXD, CER DI: 0.082UF, 10%, 50V	04222	SR205C823KAA
A44A1C3033	283-0326-00		CAP, FXD, CER DI: 0.082UF, 10%, 50V	04222	SR205C823KAA
A44A1C3034	283-0111-00		CAP, FXD, CER DI: 0.1UF, 20%, 50V	80009	283-0111-00
A44A1C3039	290-0574-00		CAP, FXD, ELCTLT: 47UF, 10%, 20V	05397	T368C476K0202AS
A44A1C3045	290-0778-00		CAP, FXD, ELCTLT: 1UF, 20%, 50V, NPLZD	54473	ECE-A50N1
A44A1C3046	290-0158-00		CAP, FXD, ELCTLT: 50UF, +75-15%, 25V	26769	40LW506B025U1A
A44A1C3047	290-0776-00		CAP, FXD, ELCTLT: 22UF, +50-20%, 10V	55680	UVX1A220MAA
A44A1C3048	283-0191-00		CAP, FXD, CER DI: 0.022UF, 20%, 50V	05397	C320C223M5U1CA
A44A1C4014	283-0111-00		CAP, FXD, CER DI: 0.1UF, 20%, 50V	80009	283-0111-00
A44A1C4016	283-0177-00		CAP, FXD, CER DI: 1UF, +80-20%, 25V	04222	SR30E105ZAA
A44A1C4046	290-0574-00		CAP, FXD, ELCTLT: 47UF, 10%, 20V	05397	T368C476K0202AS
A44A1CR1052	152-0141-02		DIODE, SIG: ULTRA FAST; 40V, 150MA, 4NS, 2PF; 1N4 152, DO-35, T&R	80009	152-0141-02
A44A1CR1053	152-0141-02		DIODE, SIG: ULTRA FAST; 40V, 150MA, 4NS, 2PF; 1N4 152, DO-35, T&R	80009	152-0141-02
A44A1CR1054	152-0141-02		DIODE, SIG: ULTRA FAST; 40V, 150MA, 4NS, 2PF; 1N4 152, DO-35, T&R	80009	152-0141-02
A44A1CR2024	152-0141-02		DIODE, SIG: ULTRA FAST; 40V, 150MA, 4NS, 2PF; 1N4 152, DO-35, T&R	80009	152-0141-02
A44A1CR3014	152-0141-02		DIODE, SIG: ULTRA FAST; 40V, 150MA, 4NS, 2PF; 1N4 152, DO-35, T&R	80009	152-0141-02
A44A1CR3031	152-0141-02		DIODE, SIG: ULTRA FAST; 40V, 150MA, 4NS, 2PF; 1N4 152, DO-35, T&R	80009	152-0141-02
A44A1CR3044	152-0323-00		DIODE, SIG: ; 50V, 1.1VF, 225MA, 20PA, 3.7PF, 1.0U S; MT5282, DO-35, T&R	14433	WG1518
A44A1CR3047	152-0333-00		SEMICON DVC, DI: SW, SI, 55V, 200MA, DO-35	07263	FDH-6012
A44A1K3034	148-0064-00		RELAY, REED: FORM A, 110MA, 28VDC	80009	148-0064-00
A44A1L4038	108-0881-00		COIL, RF: FIXED, 40.1UH	80009	108-0881-00
A44A1L4041	108-0881-00		COIL, RF: FIXED, 40.1UH	80009	108-0881-00
A44A1Q1028	151-0190-00		TRANSISTOR, SIG: BIPOLAR, NPN; 40V, 200MA, 300MHZ, AMPLIFIER; 2N3904, TO-92 EBC	80009	151-0190-00
A44A1Q2025	151-0188-00		TRANSISTOR, SIG: BIPOLAR, PNP; 40V, 200MA, 250MHZ, AMPLIFIER; 2N3906, TO-92 EBC	80009	151-0188-00

Replaceable Electrical Parts
494A/494AP Service Vol.2

Component No.	Tektronix	Serial/Assembly No.		Name & Description	Mfr.	Mfr. Part No.
	Part No.	Effective	Discont		Code	
A44A1Q2029	151-0302-00			TRANSISTOR, SIG: BIPOLAR, NPN; 40V, 800MA, 300MHZ , AMPLIFIER; 2N2222A, TO-18	80009	151-0302-00
A44A1Q2035	151-0301-00			TRANSISTOR, SIG: BIPOLAR, PNP; 60V, 600MA, 200MHZ , AMPLIFIER; 2N2907A, TO-18	80009	151-0301-00
A44A1Q2039	151-0302-00			TRANSISTOR, SIG: BIPOLAR, NPN; 40V, 800MA, 300MHZ , AMPLIFIER; 2N2222A, TO-18	80009	151-0302-00
A44A1Q2040	151-1022-00			TRANSISTOR, SIG: JFET, N-CH; 4V, 75MA, 80 OHM, SEL ECTED FOR VGS(OFF); 2N4392 FAMILY, TO-18	80009	151-1022-00
A44A1Q2045	151-0619-00			TRANSISTOR, SIG: BIPOLAR, NPN; 35V, 20MA, SUPERMA TCHED DUAL; LM394H, TO-78	80009	151-0619-00
A44A1Q2051	151-0301-00			TRANSISTOR, SIG: BIPOLAR, PNP; 60V, 600MA, 200MHZ , AMPLIFIER; 2N2907A, TO-18	80009	151-0301-00
A44A1Q2052	151-0619-00			TRANSISTOR, SIG: BIPOLAR, NPN; 35V, 20MA, SUPERMA TCHED DUAL; LM394H, TO-78	80009	151-0619-00
A44A1Q3019	151-1097-00			TRANSISTOR, SIG: JFET, P-CH; 5V, 10MA(MIN), 90 OH M, SWITCH; 2N5019 FAMILY, TO-92	22229	F5526
A44A1Q3028	151-0302-00			TRANSISTOR, SIG: BIPOLAR, NPN; 40V, 800MA, 300MHZ , AMPLIFIER; 2N2222A, TO-18	80009	151-0302-00
A44A1Q3047	151-1022-00			TRANSISTOR, SIG: JFET, N-CH; 4V, 75MA, 80 OHM, SEL ECTED FOR VGS(OFF); 2N4392 FAMILY, TO-18	80009	151-1022-00
A44A1R1011	315-0101-00			RES, FXD, FILM: 100 OHM, 5%, 0.25W	80009	315-0101-00
A44A1R1013	311-1240-00			RES, VAR, NONWV: TRMR, 25K OHM, 10%, 0.5W	80009	311-1240-00
A44A1R1014	321-0363-00			RES, FXD, FILM: 59.0K OHM, 1%, 0.125W, TC=TO	07716	CEAD59001F
A44A1R1015	321-0363-00			RES, FXD, FILM: 59.0K OHM, 1%, 0.125W, TC=TO	07716	CEAD59001F
A44A1R1018	315-0101-00			RES, FXD, FILM: 100 OHM, 5%, 0.25W	80009	315-0101-00
A44A1R1019	321-0363-00			RES, FXD, FILM: 59.0K OHM, 1%, 0.125W, TC=TO	07716	CEAD59001F
A44A1R1020	321-0001-00			RES, FXD, FILM: 10 OHM, 1%, 0.125W, TC=TO	75042	CEAT0-10R00F
A44A1R1021	321-0222-00			RES, FXD, FILM: 2.00K OHM, 1%, 0.125W, TC=TO	80009	321-0222-00
A44A1R1022	311-1240-00			RES, VAR, NONWV: TRMR, 25K OHM, 10%, 0.5W	80009	311-1240-00
A44A1R1024	321-0162-00			RES, FXD, FILM: 475 OHM, 1%, 0.125W, TC=TO	80009	321-0162-00
A44A1R1025	321-0162-00			RES, FXD, FILM: 475 OHM, 1%, 0.125W, TC=TO	80009	321-0162-00
A44A1R1026	311-1240-00			RES, VAR, NONWV: TRMR, 25K OHM, 10%, 0.5W	80009	311-1240-00
A44A1R1028	315-0102-00			RES, FXD, FILM: 1K OHM, 5%, 0.25W	80009	315-0102-00
A44A1R1029	321-0001-00			RES, FXD, FILM: 10 OHM, 1%, 0.125W, TC=TO	75042	CEAT0-10R00F
A44A1R1030	317-0102-00			RES, FXD, CMPSN: 1K OHM, 5%, 0.125W	80009	317-0102-00
A44A1R1031	311-2168-00			RES, VAR, NONWV: 10K OHM, 10%, 0.5W, 20 TURN TRIM MER, METAL FOIL	80009	311-2168-00
A44A1R1032	311-2168-00			RES, VAR, NONWV: 10K OHM, 10%, 0.5W, 20 TURN TRIM MER, METAL FOIL	80009	311-2168-00
A44A1R1034	311-2168-00			RES, VAR, NONWV: 10K OHM, 10%, 0.5W, 20 TURN TRIM MER, METAL FOIL	80009	311-2168-00
A44A1R1035	315-0102-00			RES, FXD, FILM: 1K OHM, 5%, 0.25W	80009	315-0102-00
A44A1R1036	315-0102-00			RES, FXD, FILM: 1K OHM, 5%, 0.25W	80009	315-0102-00
A44A1R1038	321-0289-07			RES, FXD, FILM: 10.0K OHM, 0.1%, 0.125W, TC=T9	80009	321-0289-07
A44A1R1039	321-0273-00			RES, FXD, FILM: 6.81K OHM, 1%, 0.125W, TC=TO	07716	CEAD68100F
A44A1R1040	310-0706-01			RES, FXD, WW: 25 OHM, 1%, 11W, TC-3.5 PPM/DEG C	80009	310-0706-01
A44A1R1041	315-0102-00			RES, FXD, FILM: 1K OHM, 5%, 0.25W	80009	315-0102-00
A44A1R1042	321-0322-00			RES, FXD, FILM: 22.1K OHM, 1%, 0.125W, TC=TO, MI, S AFETY CONTROLLED	80009	321-0322-00
A44A1R1043	321-0322-00			RES, FXD, FILM: 22.1K OHM, 1%, 0.125W, TC=TO, MI, S AFETY CONTROLLED	80009	321-0322-00
A44A1R1044	321-0090-00			RES, FXD, FILM: 84.5 OHM, 1%, 0.125W, TC=TO	80009	321-0090-00
A44A1R1045	321-0207-00			RES, FXD, FILM: 1.40K OHM, 1%, 0.125W, TC=TO	80009	321-0207-00
A44A1R1046	321-0373-00			RES, FXD, FILM: 75.0K OHM, 1%, 0.125W, TC=TO	19701	5033ED75K00F
A44A1R1047	315-0472-00			RES, FXD, FILM: 4.7K OHM, 5%, 0.25W	80009	315-0472-00
A44A1R1048	315-0302-00			RES, FXD, FILM: 3K OHM, 5%, 0.25W	80009	315-0302-00
A44A1R1049	321-0306-00			RES, FXD, FILM: 15.0K OHM, 1%, 0.125W, TC=TO	80009	321-0306-00
A44A1R1050	321-0306-00			RES, FXD, FILM: 15.0K OHM, 1%, 0.125W, TC=TO	80009	321-0306-00

Replaceable Electrical Parts
494A/494AP Service Vol. 2

Component No.	Tektronix Part No.	Serial/Assembly No. Effective Dscont	Name & Description	Mfr. Code	Mfr. Part No.
A44A1R1051	321-0306-00		RES, FXD, FILM: 15.0K OHM, 1%, 0.125W, TC=TO	80009	321-0306-00
A44A1R1052	321-0373-00		RES, FXD, FILM: 75.0K OHM, 1%, 0.125W, TC=TO	19701	5033ED75K00F
A44A1R1053	315-0102-00		RES, FXD, FILM: 1K OHM, 5%, 0.25W	80009	315-0102-00
A44A1R1054	315-0200-00		RES, FXD, FILM: 20 OHM, 5%, 0.25W	80009	315-0200-00
A44A1R1055	321-0163-00		RES, FXD, FILM: 487 OHM, 1%, 0.125W, TC=TO	07716	CEAD487ROF
A44A1R2012	307-0542-00		RES, NTWK, FXD, FI: (5)10K OHM, 5%, 0.125W	01121	106A1030R706A103
A44A1R2014	321-0383-00		RES, FXD, FILM: 95.3K OHM, 1%, 0.125W, TC=TO	07716	CEAD95301F
A44A1R2015	321-0337-00		RES, FXD, FILM: 31.6K OHM, 1%, 0.125W, TC=TO	07716	CEAD31601F
A44A1R2016	321-0222-00		RES, FXD, FILM: 2.00K OHM, 1%, 0.125W, TC=TO	80009	321-0222-00
A44A1R2017	321-0001-00		RES, FXD, FILM: 10 OHM, 1%, 0.125W, TC=TO	75042	CEAT0-10R00F
A44A1R2021	315-0512-00		RES, FXD, FILM: 5.1K OHM, 5%, 0.25W	80009	315-0512-00
A44A1R2022	321-0265-00		RES, FXD, FILM: 5.62K OHM, 1%, 0.125W, TC=TO	80009	321-0265-00
A44A1R2022	321-0373-00		RES, FXD, FILM: 75.0K OHM, 1%, 0.125W, TC=TO	19701	5033ED75K00F
A44A1R2023	315-0391-00		RES, FXD, FILM: 390 OHM, 5%, 0.25W	80009	315-0391-00
A44A1R2024	321-0193-00		RES, FXD, FILM: 1K OHM, 1%, 0.125W, TC=TO	80009	321-0193-00
A44A1R2025	321-0001-00		RES, FXD, FILM: 10 OHM, 1%, 0.125W, TC=TO	75042	CEAT0-10R00F
A44A1R2026	315-0472-00		RES, FXD, FILM: 4.7K OHM, 5%, 0.25W	80009	315-0472-00
A44A1R2027	321-0896-03		RES, FXD, FILM: 9.8K OHM, 0.25%, 0.125W, TC=T2	80009	321-0896-03
A44A1R2029	315-0510-00		RES, FXD, FILM: 51 OHM, 5%, 0.25W	80009	315-0510-00
A44A1R2031	321-0289-09		RES, FXD, FILM: 10.0K OHM, 1%, 0.125W, TC=T9	80009	321-0289-09
A44A1R2036	325-0269-00		RES, FXD, FILM: 22K OHM, 1%, 0.3W, TC=3.1PPM/DEG C	07088	K747 22K OHM 1%
A44A1R2037	325-0258-00		RES, FXD, FILM: 5.62K OHM, 0.25%, 0.3W	07088	K747 5.62K OHM
A44A1R2041	325-0323-00		RES, FXD, FILM: 10.88K OHM, 0.5%, 0.3W	07088	K747 10.88 KOHM
A44A1R2042	325-0326-00		RES, FXD, FILM: 2.67K OHM, 0.5%, 0.3W	07088	K747 2.67 KOHM
A44A1R2043	325-0271-00		RES, FXD, FILM: 51.1K OHM, 0.25%, 0.3W	07088	K747 51.1K OHM
A44A1R2044	315-0274-00		RES, FXD, FILM: 270K OHM, 5%, 0.25W	80009	315-0274-00
A44A1R2051	325-0326-00		RES, FXD, FILM: 2.67K OHM, 0.5%, 0.3W	07088	K747 2.67 KOHM
A44A1R2052	325-0327-00		RES, FXD, FILM: 4.72K OHM, 0.5%, 0.3W	07088	K747 4.72 KOHM
A44A1R2053	321-0263-00		RES, FXD, FILM: 5.36K OHM, 1%, 0.125W, TC=TO	07716	CEAD53600F
A44A1R2054	315-0102-00		RES, FXD, FILM: 1K OHM, 5%, 0.25W	80009	315-0102-00
A44A1R3012	315-0203-00		RES, FXD, FILM: 20K OHM, 5%, 0.25W	80009	315-0203-00
A44A1R3013	315-0100-00		RES, FXD, FILM: 10 OHM, 5%, 0.25W	19701	5043CX10R00J
A44A1R3014	321-0306-00		RES, FXD, FILM: 15.0K OHM, 1%, 0.125W, TC=TO	80009	321-0306-00
A44A1R3015	321-0289-00		RES, FXD, FILM: 10.0K OHM, 1%, 0.125W, TC=TO	57668	FXE10K0
A44A1R3025	321-0001-00		RES, FXD, FILM: 10 OHM, 1%, 0.125W, TC=TO	75042	CEAT0-10R00F
A44A1R3027	315-0100-00		RES, FXD, FILM: 10 OHM, 5%, 0.25W	19701	5043CX10R00J
A44A1R3028	315-0912-00		RES, FXD, FILM: 9.1K OHM, 5%, 0.25W	80009	315-0912-00
A44A1R3031	315-0562-00		RES, FXD, FILM: 5.6K OHM, 5%, 0.25W	80009	315-0562-00
A44A1R3032	315-0100-00		RES, FXD, FILM: 10 OHM, 5%, 0.25W	19701	5043CX10R00J
A44A1R3040	315-0154-00		RES, FXD, FILM: 150K OHM, 5%, 0.25W	80009	315-0154-00
A44A1R3046	315-0222-00		RES, FXD, FILM: 2.2K OHM, 5%, 0.25W	80009	315-0222-00
A44A1R3048	315-0102-00		RES, FXD, FILM: 1K OHM, 5%, 0.25W	80009	315-0102-00
A44A1R3049	315-0123-00		RES, FXD, FILM: 12K OHM, 5%, 0.25W	80009	315-0123-00
A44A1R4012	315-0473-00		RES, FXD, FILM: 47K OHM, 5%, 0.25W	80009	315-0473-00
A44A1R4014	315-0101-00		RES, FXD, FILM: 100 OHM, 5%, 0.25W	80009	315-0101-00
A44A1R4015	315-0101-00		RES, FXD, FILM: 100 OHM, 5%, 0.25W	80009	315-0101-00
A44A1R4016	315-0102-00		RES, FXD, FILM: 1K OHM, 5%, 0.25W	80009	315-0102-00
A44A1R4037	315-0470-00		RES, FXD, FILM: 47 OHM, 5%, 0.25W	80009	315-0470-00
A44A1R4038	307-0103-00		RES, FXD, CMPSN: 2.7 OHM, 5%, 0.25W	80009	307-0103-00
A44A1R4043	307-0103-00		RES, FXD, CMPSN: 2.7 OHM, 5%, 0.25W	80009	307-0103-00
A44A1R4044	315-0470-00		RES, FXD, FILM: 47 OHM, 5%, 0.25W	80009	315-0470-00
A44A1U1013	156-1160-00		IC, LINEAR: BIPOLAR, VOLTAGE REGULATOR; POSITIV E, 12V, 100MA, 4%; LM78L12ACH, TO-39	80009	156-1160-00
A44A1U1016	156-1256-00		IC, MISC: JFET, ANALOG MUX; 4-CHANNEL, WITH SHU NT DIODE & COMPENSATION FET; IH5010, DIP14.3	32293	IH5010CDD/CJD
A44A1U1018	156-1207-00		IC, LINEAR: BIPOLAR, VOLTAGE REGULATOR; NEGATIV E, -12V, 500MA, 3%; LM320H-12, TO-39	80009	156-1207-00

Replaceable Electrical Parts
494A/494AP Service Vol.2

Component No.	Tektronix		Serial/Assembly No.	Name & Description	Mfr. Code	Mfr. Part No.
	Part No.	Effective Dscont				
A44A1U1025	156-0158-00			IC, LINEAR: BIPOLAR, OP-AMP; DUAL; MC1458P1, DIP08.3	80009	156-0158-00
A44A1U2018	156-0512-00			IC, LINEAR: BIPOLAR, OP-AMP; LOW INPUT BIAS CURRENT, UNCOMPENSATED; LM308N, DIP08.3	80009	156-0512-00
A44A1U2032	156-0512-00			IC, LINEAR: BIPOLAR, OP-AMP; LOW INPUT BIAS CURRENT, UNCOMPENSATED; LM308N, DIP08.3	80009	156-0512-00
A44A1U2043	156-0512-00			IC, LINEAR: BIPOLAR, OP-AMP; LOW INPUT BIAS CURRENT, UNCOMPENSATED; LM308N, DIP08.3	80009	156-0512-00
A44A1U2052	156-0512-00			IC, LINEAR: BIPOLAR, OP-AMP; LOW INPUT BIAS CURRENT, UNCOMPENSATED; LM308N, DIP08.3	80009	156-0512-00
A44A1U3014	156-0411-00			IC, LINEAR: BIPOLAR, COMPARATOR; QUAD, SINGLE SUPPLY, 300NS; LM339N, DIP14.3	80009	156-0411-00
A44A1U3022	156-0967-00			IC, CONVERTER: BIPOLAR, D/A; 10 BIT, 300NS, CURRENT OUT, REFERENCE; AD561JD, DIP16.3	24355	AD561J
A44A1U4017	156-0913-00			IC, DIGITAL: LSTTL, FLIP FLOP; OCTAL D-TYPE, ENABLE; 74LS377, DIP20.3, TUBE	80009	156-0913-00
A44A1U4022	156-0913-00			IC, DIGITAL: LSTTL, FLIP FLOP; OCTAL D-TYPE, ENABLE; 74LS377, DIP20.3, TUBE	80009	156-0913-00
A44A1U4024	156-0913-00			IC, DIGITAL: LSTTL, FLIP FLOP; OCTAL D-TYPE, ENABLE; 74LS377, DIP20.3, TUBE	80009	156-0913-00
A44A1U4034	156-0469-00			IC, DIGITAL: LSTTL, DEMUX/DECODER; 3-TO-8 DECODER; 74LS138, DIP16.3, TUBE	80009	156-0469-00
A44A1VR1055	152-0526-00			DIODE, ZENER: . . . 6.35V, 1%, 0.4W; 1N829A FMLY, DO-7	14552	DT840615A
A44A1W1027	131-0566-00			BUS, CONDUCTOR: DUMMY RES, 0.094 OD X 0.225 L	80009	131-0566-00
A44A1W2034	131-0566-00			BUS, CONDUCTOR: DUMMY RES, 0.094 OD X 0.225 L	80009	131-0566-00
A44A1W2045	131-0566-00			BUS, CONDUCTOR: DUMMY RES, 0.094 OD X 0.225 L	80009	131-0566-00
A46	672-0165-00			CIRCUIT BD ASSY: CENTER FREQ CONTROL	80009	672-0165-00
A46A1	670-9094-01			CIRCUIT BD ASSY: CENTER FREQ CONTROL	80009	670-9094-01
A46A1C1029	283-5004-00			CAP, FXD, CER DI: 0.1UF, 10%, 25V	80009	283-5004-00
A46A1C1030	283-5002-00			CAP, FXD, CER DI: 1000PF, 10%, 50V	80009	283-5002-00
A46A1C1033	283-5004-00			CAP, FXD, CER DI: 0.1UF, 10%, 25V	80009	283-5004-00
A46A1C1043	285-0894-00			CAP, FXD, PLASTIC: 5UF, 5%, 50V	80009	285-0894-00
A46A1C1061	283-5004-00			CAP, FXD, CER DI: 0.1UF, 10%, 25V	80009	283-5004-00
A46A1C1065	283-5002-00			CAP, FXD, CER DI: 1000PF, 10%, 50V	80009	283-5002-00
A46A1C1066	283-5004-00			CAP, FXD, CER DI: 0.1UF, 10%, 25V	80009	283-5004-00
A46A1C2015	283-5001-00			CAP, FXD, CER DI: 100PF, 5%, 50V	80009	283-5001-00
A46A1C2037	290-5001-00			CAP, FXD, ELCTLT: 10UF, 20%, 16V	TK0900	ALCHIP-S16V10UF
A46A1C2040	290-5001-00			CAP, FXD, ELCTLT: 10UF, 20%, 16V	TK0900	ALCHIP-S16V10UF
A46A1C2043	290-5001-00			CAP, FXD, ELCTLT: 10UF, 20%, 16V	TK0900	ALCHIP-S16V10UF
A46A1C2050	283-5001-00			CAP, FXD, CER DI: 100PF, 5%, 50V	80009	283-5001-00
A46A1C2069	290-5001-00			CAP, FXD, ELCTLT: 10UF, 20%, 16V	TK0900	ALCHIP-S16V10UF
A46A1C2074	290-5001-00			CAP, FXD, ELCTLT: 10UF, 20%, 16V	TK0900	ALCHIP-S16V10UF
A46A1C2076	285-0894-00			CAP, FXD, PLASTIC: 5UF, 5%, 50V	80009	285-0894-00
A46A1C3040	290-5001-00			CAP, FXD, ELCTLT: 10UF, 20%, 16V	TK0900	ALCHIP-S16V10UF
A46A1C3045	290-5001-00			CAP, FXD, ELCTLT: 10UF, 20%, 16V	TK0900	ALCHIP-S16V10UF
A46A1C3076	290-5001-00			CAP, FXD, ELCTLT: 10UF, 20%, 16V	TK0900	ALCHIP-S16V10UF
A46A1CR1024	152-5000-00			SEMICONV DVC, DI: SW, SI, 70V, COM CATHODE	80009	152-5000-00
A46A1CR1025	152-5000-00			SEMICONV DVC, DI: SW, SI, 70V, COM CATHODE	80009	152-5000-00
A46A1CR1026	152-5000-00			SEMICONV DVC, DI: SW, SI, 70V, COM CATHODE	80009	152-5000-00
A46A1CR1033	152-5000-00			SEMICONV DVC, DI: SW, SI, 70V, COM CATHODE	80009	152-5000-00
A46A1CR1035	152-5000-00			SEMICONV DVC, DI: SW, SI, 70V, COM CATHODE	80009	152-5000-00
A46A1CR1056	152-5000-00			SEMICONV DVC, DI: SW, SI, 70V, COM CATHODE	80009	152-5000-00
A46A1CR1058	152-5000-00			SEMICONV DVC, DI: SW, SI, 70V, COM CATHODE	80009	152-5000-00
A46A1CR1064	152-5000-00			SEMICONV DVC, DI: SW, SI, 70V, COM CATHODE	80009	152-5000-00
A46A1CR1067	152-5000-00			SEMICONV DVC, DI: SW, SI, 70V, COM CATHODE	80009	152-5000-00
A46A1CR1069	152-5000-00			SEMICONV DVC, DI: SW, SI, 70V, COM CATHODE	80009	152-5000-00
A46A1L4055	108-0417-01			COIL, RF: FIXED, 110UH	80009	108-0417-01

Replaceable Electrical Parts
494A/494AP Service Vol.2

Component No.	Tektronix Part No.	Serial/Assembly No. Effective Dscnt	Name & Description	Mfr. Code	Mfr. Part No.
A46A1Q1024	151-5000-00		TRANSISTOR, SIG: BIPOLAR, PNP; 40V, 200MA, 250MHZ, AMPLIFIER; MMBT3906L, TO-236/SOT-23, 8MM T&R	04713	MMBT3906LT1
A46A1Q1058	151-5001-00		TRANSISTOR, SIG: BIPOLAR, NPN; 40V, 200MA, 300MHZ, AMPLIFIER; MMBT3904L, TO-236/SOT-23, 8MM T&R	80009	151-5001-00
A46A1Q1061	151-5000-00		TRANSISTOR, SIG: BIPOLAR, PNP; 40V, 200MA, 250MHZ, AMPLIFIER; MMBT3906L, TO-236/SOT-23, 8MM T&R	04713	MMBT3906LT1
A46A1Q1065	151-5002-00		TRANSISTOR, SIG: JFET, N-CH; 5V, 75MA, 60 OHM, SWITCH; MMBF4392L, SOT-23, 8MM T&R	80009	151-5002-00
A46A1Q2017	151-5001-00		TRANSISTOR, SIG: BIPOLAR, NPN; 40V, 200MA, 300MHZ, AMPLIFIER; MMBT3904L, TO-236/SOT-23, 8MM T&R	80009	151-5001-00
A46A1Q2031	151-5002-00		TRANSISTOR, SIG: JFET, N-CH; 5V, 75MA, 60 OHM, SWITCH; MMBF4392L, SOT-23, 8MM T&R	80009	151-5002-00
A46A1R1011	321-1741-00		RES SET, MATCHED: 10K/10K OHM, 1%, 0.125W (MATCHED SET W/A46A1R1012)	80009	321-1741-00
A46A1R1012	321-1741-00		RES SET, MATCHED: 10K/10K OHM, 1%, 0.125W (MATCHED SET W/A46A1R1011)	80009	321-1741-00
A46A1R1013	321-1741-00		RES SET, MATCHED: 10K/10K OHM, 1%, 0.125W (MATCHED SET W/A46A1R1014)	80009	321-1741-00
A46A1R1014	321-1741-00		RES SET, MATCHED: 10K/10K OHM, 1%, 0.125W (MATCHED SET W/A46A1R1013)	80009	321-1741-00
A46A1R1015	321-1742-00		RES SET, MATCHED: 5K/10K/10.5K OHM, 1%, 0.125W (MATCHED SET W/A46A1R1016, A46A1R1020)	80009	321-1742-00
A46A1R1016	321-1742-00		RES SET, MATCHED: 5K/10K/10.5K OHM, 1%, 0.125W (MATCHED SET W/A46A1R1015, A46A1R1020)	80009	321-1742-00
A46A1R1020	321-1742-00		RES SET, MATCHED: 5K/10K/10.5K OHM, 1%, 0.125W (MATCHED SET W/A46A1R1015, A46A1R1016)	80009	321-1742-00
A46A1R1021	321-5030-00		RES, FXD, FILM: 10.0K, 1%, 0.125W	80009	321-5030-00
A46A1R1022	321-5030-00		RES, FXD, FILM: 10.0K, 1%, 0.125W	80009	321-5030-00
A46A1R1023	321-5030-00		RES, FXD, FILM: 10.0K, 1%, 0.125W	80009	321-5030-00
A46A1R1024	321-5038-00		RES, FXD, FILM: 47.5K, 1%, 0.125W	80009	321-5038-00
A46A1R1025	321-5030-00		RES, FXD, FILM: 10.0K, 1%, 0.125W	80009	321-5030-00
A46A1R1026	321-5011-00		RES, FXD, FILM: 274 OHM, 1%, 0.125W	80009	321-5011-00
A46A1R1027	321-5018-00		RES, FXD, FILM: 1.00K, 1%, 0.125W	80009	321-5018-00
A46A1R1028	311-1238-00		RES, VAR, NONWV: TRMR, 5K OHM, 0.5W	80009	311-1238-00
A46A1R1029	321-5047-00		RES, FXD, FILM: 100K, 1%, 0.125W	80009	321-5047-00
A46A1R1030	321-5049-00		RES, FXD, FILM: 1 MEG, 1%, 0.125W	80009	321-5049-00
A46A1R1031	321-5049-00		RES, FXD, FILM: 1 MEG, 1%, 0.125W	80009	321-5049-00
A46A1R1032	311-1336-00		RES, VAR, NONWV: TRMR, 100K OHM, 0.75W	02111	43P104T672
A46A1R1033	321-5049-00		RES, FXD, FILM: 1 MEG, 1%, 0.125W	80009	321-5049-00
A46A1R1034	321-5018-00		RES, FXD, FILM: 1.00K, 1%, 0.125W	80009	321-5018-00
A46A1R1035	321-5030-00		RES, FXD, FILM: 10.0K, 1%, 0.125W	80009	321-5030-00
A46A1R1036	321-0604-00		RES, FXD, FILM: 30K OHM, 0.25%, 0.125W, TC=T2	80009	321-0604-00
A46A1R1039	321-5006-00		RES, FXD, FILM: 100 OHM, 1%, 0.125W	80009	321-5006-00
A46A1R1048	321-1741-00		RES SET, MATCHED: 10K/10K OHM, 1%, 0.125W (MATCHED SET W/A46A1R1049)	80009	321-1741-00
A46A1R1049	321-1741-00		RES SET, MATCHED: 10K/10K OHM, 1%, 0.125W (MATCHED SET W/A46A1R1048)	80009	321-1741-00
A46A1R1050	321-1741-00		RES SET, MATCHED: 10K/10K OHM, 1%, 0.125W (MATCHED SET W/A46A1R1051)	80009	321-1741-00
A46A1R1051	321-1741-00		RES SET, MATCHED: 10K/10K OHM, 1%, 0.125W (MATCHED SET W/A46A1R1050)	80009	321-1741-00
A46A1R1052	321-1742-00		RES SET, MATCHED: 5K/10K/10.5K OHM, 1%, 0.125W (MATCHED SET W/A46A1R1053, A46A1R1055)	80009	321-1742-00
A46A1R1053	321-1742-00		RES SET, MATCHED: 5K/10K/10.5K OHM, 1%, 0.125W (MATCHED SET W/A46A1R1052, A46A1R1055)	80009	321-1742-00
A46A1R1054	321-5030-00		RES, FXD, FILM: 10.0K, 1%, 0.125W	80009	321-5030-00
A46A1R1055	321-1742-00		RES SET, MATCHED: 5K/10K/10.5K OHM, 1%, 0.125W (MATCHED SET W/A46A1R1052, A46A1R1053)	80009	321-1742-00
A46A1R1056	321-5038-00		RES, FXD, FILM: 47.5K, 1%, 0.125W	80009	321-5038-00
A46A1R1057	321-5006-00		RES, FXD, FILM: 100 OHM, 1%, 0.125W	80009	321-5006-00

Replaceable Electrical Parts
494A/494AP Service Vol.2

Component No.	Tektronix	Serial/Assembly No.		Name & Description	Mfr.	Mfr. Part No.
	Part No.	Effective	Discont		Code	
A46AIR1058	321-5018-00			RES, FXD, FILM: 1.00K, 1%, 0.125W	80009	321-5018-00
A46AIR1059	321-5011-00			RES, FXD, FILM: 274 OHM, 1%, 0.125W	80009	321-5011-00
A46AIR1061	321-5018-00			RES, FXD, FILM: 1.00K, 1%, 0.125W	80009	321-5018-00
A46AIR1062	321-5030-00			RES, FXD, FILM: 10.0K, 1%, 0.125W	80009	321-5030-00
A46AIR1063	321-5030-00			RES, FXD, FILM: 10.0K, 1%, 0.125W	80009	321-5030-00
A46AIR1064	321-5047-00			RES, FXD, FILM: 100K, 1%, 0.125W	80009	321-5047-00
A46AIR1065	321-5049-00			RES, FXD, FILM: 1 MEG, 1%, 0.125W	80009	321-5049-00
A46AIR1066	321-5049-00			RES, FXD, FILM: 1 MEG, 1%, 0.125W	80009	321-5049-00
A46AIR1067	321-5049-00			RES, FXD, FILM: 1 MEG, 1%, 0.125W	80009	321-5049-00
A46AIR1068	321-5018-00			RES, FXD, FILM: 1.00K, 1%, 0.125W	80009	321-5018-00
A46AIR1070	321-0385-00			RES, FXD, FILM: 100K OHM, 1%, 0.125W, TC=TO	80009	321-0385-00
A46AIR1073	321-5006-00			RES, FXD, FILM: 100 OHM, 1%, 0.125W	80009	321-5006-00
A46AIR2017	321-5006-00			RES, FXD, FILM: 100 OHM, 1%, 0.125W	80009	321-5006-00
A46AIR2019	321-5018-00			RES, FXD, FILM: 1.00K, 1%, 0.125W	80009	321-5018-00
A46AIR2028	321-5000-00			RES, FXD, FILM: 10 OHM, 1%, 0.125W	57668	MCR18EZHFW10E
A46AIR2029	321-5000-00			RES, FXD, FILM: 10 OHM, 1%, 0.125W	57668	MCR18EZHFW10E
A46AIR2038	321-5043-00			RES, FXD, FILM: 47.5 OHM, 1%, 0.125W	80009	321-5043-00
A46AIR2039	321-5006-00			RES, FXD, FILM: 100 OHM, 1%, 0.125W	80009	321-5006-00
A46AIR2046	321-5043-00			RES, FXD, FILM: 47.5 OHM, 1%, 0.125W	80009	321-5043-00
A46AIR2059	321-5000-00			RES, FXD, FILM: 10 OHM, 1%, 0.125W	57668	MCR18EZHFW10E
A46AIR2060	321-5000-00			RES, FXD, FILM: 10 OHM, 1%, 0.125W	57668	MCR18EZHFW10E
A46AIR2061	321-5030-00			RES, FXD, FILM: 10.0K, 1%, 0.125W	80009	321-5030-00
A46AIR2067	321-5030-00			RES, FXD, FILM: 10.0K, 1%, 0.125W	80009	321-5030-00
A46AIR2069	321-5043-00			RES, FXD, FILM: 47.5 OHM, 1%, 0.125W	80009	321-5043-00
A46AIR2074	321-5043-00			RES, FXD, FILM: 47.5 OHM, 1%, 0.125W	80009	321-5043-00
A46AIR3040	311-1238-00			RES, VAR, NONNW: TRMR, 5K OHM, 0.5W	80009	311-1238-00
A46AIR3075	321-5006-00			RES, FXD, FILM: 100 OHM, 1%, 0.125W	80009	321-5006-00
A46AIR4040	311-1241-00			RES, VAR, NONNW: TRMR, 100K OHM, 0.5W	80009	311-1241-00
A46AIR4062	321-5006-00			RES, FXD, FILM: 100 OHM, 1%, 0.125W	80009	321-5006-00
A46AIR4063	321-5006-00			RES, FXD, FILM: 100 OHM, 1%, 0.125W	80009	321-5006-00
A46A1U1030	156-1851-00			IC, LINEAR: BIPOLAR, OP-AMP; SINGLE, LOW NOISE; 0 P27GP, DIP08.3	80009	156-1851-00
A46A1U1035	156-1582-00			IC, LINEAR: BIPOLAR, OP-AMP; LOW OFFSET VOLTAGE ; OP07CN, DIP08.3	80009	156-1582-00
A46A1U1055	156-5000-00			IC, LINEAR: BIPOLAR, COMPARATOR; OPEN COLLECTOR ; 200NS; LM311D, SO8.150, TUBE	04713	LM311D
A46A1U1065	156-1851-00			IC, LINEAR: BIPOLAR, OP-AMP; SINGLE, LOW NOISE; 0 P27GP, DIP08.3	80009	156-1851-00
A46A1U2010	156-1851-00			IC, LINEAR: BIPOLAR, OP-AMP; SINGLE, LOW NOISE; 0 P27GP, DIP08.3	80009	156-1851-00
A46A1U2015	156-1851-00			IC, LINEAR: BIPOLAR, OP-AMP; SINGLE, LOW NOISE; 0 P27GP, DIP08.3	80009	156-1851-00
A46A1U2019	156-5000-00			IC, LINEAR: BIPOLAR, COMPARATOR; OPEN COLLECTOR ; 200NS; LM311D, SO8.150, TUBE	04713	LM311D
A46A1U2020	156-1548-01			IC, CONVERTER: CMOS, D/A; 12 BIT, CURRENT OUT, MULTIPLYING; AD7541AJN, DIP18.3	80009	156-1548-01
A46A1U2030	156-1548-01			IC, CONVERTER: CMOS, D/A; 12 BIT, CURRENT OUT, MULTIPLYING; AD7541AJN, DIP18.3	80009	156-1548-01
A46A1U2045	156-1851-00			IC, LINEAR: BIPOLAR, OP-AMP; SINGLE, LOW NOISE; 0 P27GP, DIP08.3	80009	156-1851-00
A46A1U2050	156-1851-00			IC, LINEAR: BIPOLAR, OP-AMP; SINGLE, LOW NOISE; 0 P27GP, DIP08.3	80009	156-1851-00
A46A1U2055	156-1548-01			IC, CONVERTER: CMOS, D/A; 12 BIT, CURRENT OUT, MULTIPLYING; AD7541AJN, DIP18.3	80009	156-1548-01
A46A1U2060	156-1548-01			IC, CONVERTER: CMOS, D/A; 12 BIT, CURRENT OUT, MULTIPLYING; AD7541AJN, DIP18.3	80009	156-1548-01
A46A1U2070	156-1582-00			IC, LINEAR: BIPOLAR, OP-AMP; LOW OFFSET VOLTAGE ; OP07CN, DIP08.3	80009	156-1582-00

Replaceable Electrical Parts
494A/494AP Service Vol.2

Component No.	Tektronix Part No.	Serial/Assembly No. Effective Dscont	Name & Description	Mfr. Code	Mfr. Part No.
A46A1U3015	156-5035-00		IC,DIGITAL:LSTTL,FLIP FLOP;OCTAL D-TYPE, 3-STATE;74LS374,SO20.300,TUBE	80009	156-5035-00
A46A1U3025	156-5035-00		IC,DIGITAL:LSTTL,FLIP FLOP;OCTAL D-TYPE, 3-STATE;74LS374,SO20.300,TUBE	80009	156-5035-00
A46A1U3035	156-5035-00		IC,DIGITAL:LSTTL,FLIP FLOP;OCTAL D-TYPE, 3-STATE;74LS374,SO20.300,TUBE	80009	156-5035-00
A46A1U3050	156-5035-00		IC,DIGITAL:LSTTL,FLIP FLOP;OCTAL D-TYPE, 3-STATE;74LS374,SO20.300,TUBE	80009	156-5035-00
A46A1U3060	156-5035-00		IC,DIGITAL:LSTTL,FLIP FLOP;OCTAL D-TYPE, 3-STATE;74LS374,SO20.300,TUBE	80009	156-5035-00
A46A1U3070	156-5035-00		IC,DIGITAL:LSTTL,FLIP FLOP;OCTAL D-TYPE, 3-STATE;74LS374,SO20.300,TUBE	80009	156-5035-00
A46A1U4015	156-5032-00		IC,DIGITAL:LSTTL,GATES;QUAD 2-INPUT NOR;74LS02,SO14.150,TUBE	80009	156-5032-00
A46A1U4025	156-5035-00		IC,DIGITAL:LSTTL,FLIP FLOP;OCTAL D-TYPE, 3-STATE;74LS374,SO20.300,TUBE	80009	156-5035-00
A46A1U4035	156-5034-00		IC,DIGITAL:LSTTL,BUFFER;NONINV, OCTAL, LINE DRIVER, 3-STATE;74LS244,SO20.300,TUBE	80009	156-5034-00
A46A1U4045	156-5033-00		IC,DIGITAL:LSTTL,DEMUX/DECODER;3-TO-8 DECODER;74LS138,SO16.150,TUBE	80009	156-5033-00
A46A1U4060	156-5032-00		IC,DIGITAL:LSTTL,GATES;QUAD 2-INPUT NOR;74LS02,SO14.150,TUBE	80009	156-5032-00
A48	672-0157-00		CIRCUIT BD ASSY:SPAN ATTENUATOR	80009	672-0157-00
A48A1	670-5550-01		CIRCUIT BD ASSY:SPAN ATTENUATOR	80009	670-5550-01
A48A1C1013	283-0111-00		CAP,FXD,CER DI:0.1UF,20%,50V	80009	283-0111-00
A48A1C1014	283-0111-00		CAP,FXD,CER DI:0.1UF,20%,50V	80009	283-0111-00
A48A1C1019	283-0111-00		CAP,FXD,CER DI:0.1UF,20%,50V	80009	283-0111-00
A48A1C1023	283-0111-00		CAP,FXD,CER DI:0.1UF,20%,50V	80009	283-0111-00
A48A1C1024	283-0111-00		CAP,FXD,CER DI:0.1UF,20%,50V	80009	283-0111-00
A48A1C1027	283-0111-00		CAP,FXD,CER DI:0.1UF,20%,50V	80009	283-0111-00
A48A1C1029	283-0111-00		CAP,FXD,CER DI:0.1UF,20%,50V	80009	283-0111-00
A48A1C1032	283-0111-00		CAP,FXD,CER DI:0.1UF,20%,50V	80009	283-0111-00
A48A1C1034	283-0111-00		CAP,FXD,CER DI:0.1UF,20%,50V	80009	283-0111-00
A48A1C1036	290-0535-00		CAP,FXD,ELCTLT:33UF,20%,10V TANTALUM	80009	290-0535-00
A48A1C1058	283-0111-00		CAP,FXD,CER DI:0.1UF,20%,50V	80009	283-0111-00
A48A1C2024	283-0359-00		CAP,FXD,CER DI:1000PF,10%,200V	04222	SR212A102KAA
A48A1C2026	283-0111-00		CAP,FXD,CER DI:0.1UF,20%,50V	80009	283-0111-00
A48A1C2035	283-0111-00		CAP,FXD,CER DI:0.1UF,20%,50V	80009	283-0111-00
A48A1C2036	283-0111-00		CAP,FXD,CER DI:0.1UF,20%,50V	80009	283-0111-00
A48A1C2037	283-0672-00		CAP,FXD,MICA DI:200PF,1%,500V	80009	283-0672-00
A48A1C2042	281-0525-00		CAP,FXD,CER DI:470PF,+/-94PF,500V	80009	281-0525-00
A48A1C2044	281-0523-00		CAP,FXD,CER DI:100PF,20%,350V	80009	281-0523-00
A48A1C2050	283-0330-00		CAP,FXD,CER DI:100PF,5%,50V	80009	283-0330-00
A48A1C2052	283-0111-00		CAP,FXD,CER DI:0.1UF,20%,50V	80009	283-0111-00
A48A1C3031	283-0111-00		CAP,FXD,CER DI:0.1UF,20%,50V	80009	283-0111-00
A48A1C3032	283-0111-00		CAP,FXD,CER DI:0.1UF,20%,50V	80009	283-0111-00
A48A1C4035	283-0111-00		CAP,FXD,CER DI:0.1UF,20%,50V	80009	283-0111-00
A48A1C4038	290-0158-00		CAP,FXD,ELCTLT:50UF,+75-15%,25V	26769	40LW506B025U1A
A48A1C4056	290-0574-00		CAP,FXD,ELCTLT:47UF,10%,20V	05397	T368C476K0202AS
A48A1C5018	283-0111-00		CAP,FXD,CER DI:0.1UF,20%,50V	80009	283-0111-00
A48A1C5038	290-0158-00		CAP,FXD,ELCTLT:50UF,+75-15%,25V	26769	40LW506B025U1A
A48A1C5048	290-0574-00		CAP,FXD,ELCTLT:47UF,10%,20V	05397	T368C476K0202AS
A48A1C5055	290-0722-00		CAP,FXD,ELCTLT:100 UF,20%,10V	80009	290-0722-00
A48A1CR1049	152-0141-02		DIODE,SIG:,ULTRA FAST;40V,150MA,4NS,2PF;1N4152,DO-35,T&R	80009	152-0141-02
A48A1CR1051	152-0141-02		DIODE,SIG:,ULTRA FAST;40V,150MA,4NS,2PF;1N4152,DO-35,T&R	80009	152-0141-02

Replaceable Electrical Parts
494A/494AP Service Vol.2

Component No.	Tektronix Part No.	Serial/Assembly No.		Name & Description	Mfr. Code	Mfr. Part No.
		Effective	Discnt			
A48A1CR1056	152-0141-02			DIODE, SIG: ULTRA FAST; 40V, 150MA, 4NS, 2PF; 1N4 152, DO-35, T&R	80009	152-0141-02
A48A1CR1061	152-0141-02			DIODE, SIG: ULTRA FAST; 40V, 150MA, 4NS, 2PF; 1N4 152, DO-35, T&R	80009	152-0141-02
A48A1CR2051	152-0141-02			DIODE, SIG: ULTRA FAST; 40V, 150MA, 4NS, 2PF; 1N4 152, DO-35, T&R	80009	152-0141-02
A48A1CR2053	152-0141-02			DIODE, SIG: ULTRA FAST; 40V, 150MA, 4NS, 2PF; 1N4 152, DO-35, T&R	80009	152-0141-02
A48A1CR3056	152-0141-02			DIODE, SIG: ULTRA FAST; 40V, 150MA, 4NS, 2PF; 1N4 152, DO-35, T&R	80009	152-0141-02
A48A1CR4056	152-0141-02			DIODE, SIG: ULTRA FAST; 40V, 150MA, 4NS, 2PF; 1N4 152, DO-35, T&R	80009	152-0141-02
A48A1CR4062	152-0141-02			DIODE, SIG: ULTRA FAST; 40V, 150MA, 4NS, 2PF; 1N4 152, DO-35, T&R	80009	152-0141-02
A48A1CR4068	152-0141-02			DIODE, SIG: ULTRA FAST; 40V, 150MA, 4NS, 2PF; 1N4 152, DO-35, T&R	80009	152-0141-02
A48A1CR4069	152-0141-02			DIODE, SIG: ULTRA FAST; 40V, 150MA, 4NS, 2PF; 1N4 152, DO-35, T&R	80009	152-0141-02
A48A1K3065	148-0079-00			RELAY, REED: 2 FORM A, COIL 5 VDC 200 OHM, CON TACTS 28 VDC 110 MA	80009	148-0079-00
A48A1K3075	148-0079-00			RELAY, REED: 2 FORM A, COIL 5 VDC 200 OHM, CON TACTS 28 VDC 110 MA	80009	148-0079-00
A48A1K4055	148-0064-00			RELAY, REED: FORM A, 110MA, 28VDC	80009	148-0064-00
A48A1K4062	148-0064-00			RELAY, REED: FORM A, 110MA, 28VDC	80009	148-0064-00
A48A1K4072	148-0079-00			RELAY, REED: 2 FORM A, COIL 5 VDC 200 OHM, CON TACTS 28 VDC 110 MA	80009	148-0079-00
A48A1L4048	108-0881-00			COIL, RF: FIXED, 40.1UH	80009	108-0881-00
A48A1L4053	108-0417-01			COIL, RF: FIXED, 110UH	80009	108-0417-01
A48A1L4055	108-0881-00			COIL, RF: FIXED, 40.1UH	80009	108-0881-00
A48A1Q2023	151-0301-00			TRANSISTOR, SIG: BIPOLAR, PNP; 60V, 600MA, 200MHZ, AMPLIFIER; 2N2907A, TO-18	80009	151-0301-00
A48A1Q2025	151-1022-00			TRANSISTOR, SIG: JFET, N-CH; 4V, 75MA, 80 OHM, SELECTED FOR VGS(OFF); 2N4392 FAMILY, TO-18	80009	151-1022-00
A48A1Q2028	151-1022-00			TRANSISTOR, SIG: JFET, N-CH; 4V, 75MA, 80 OHM, SELECTED FOR VGS(OFF); 2N4392 FAMILY, TO-18	80009	151-1022-00
A48A1Q2062	151-0390-00			TRANSISTOR, PWR: BIPOLAR, NPN; 45V, 2.0A, 100MHZ, AMPLIFIER, DARLINGTON; MPSU45, UNIWATT	80009	151-0390-00
A48A1Q3056	151-0391-00			TRANSISTOR, PWR: BIPOLAR, PNP; 45V, 2.0A, 100MHZ, AMPLIFIER, DARLINGTON; MPSU95, UNIWATT	80009	151-0391-00
A48A1R1013	315-0103-00			RES, FXD, FILM: 10K OHM, 5%, 0.25W	80009	315-0103-00
A48A1R1014	315-0103-00			RES, FXD, FILM: 10K OHM, 5%, 0.25W	80009	315-0103-00
A48A1R1019	315-0103-00			RES, FXD, FILM: 10K OHM, 5%, 0.25W	80009	315-0103-00
A48A1R1023	315-0103-00			RES, FXD, FILM: 10K OHM, 5%, 0.25W	80009	315-0103-00
A48A1R1024	315-0103-00			RES, FXD, FILM: 10K OHM, 5%, 0.25W	80009	315-0103-00
A48A1R1027	315-0103-00			RES, FXD, FILM: 10K OHM, 5%, 0.25W	80009	315-0103-00
A48A1R1032	315-0103-00			RES, FXD, FILM: 10K OHM, 5%, 0.25W	80009	315-0103-00
A48A1R1033	315-0472-00			RES, FXD, FILM: 4.7K OHM, 5%, 0.25W	80009	315-0472-00
A48A1R1034	315-0103-00			RES, FXD, FILM: 10K OHM, 5%, 0.25W	80009	315-0103-00
A48A1R1046	315-0106-00			RES, FXD, FILM: 10M OHM, 5%, 0.25W	01121	CB1065
A48A1R1052	315-0431-00			RES, FXD, FILM: 430 OHM, 5%, 0.25W	80009	315-0431-00
A48A1R1054	315-0102-00			RES, FXD, FILM: 1K OHM, 5%, 0.25W	80009	315-0102-00
A48A1R1056	321-0222-00			RES, FXD, FILM: 2.00K OHM, 1%, 0.125W, TC=TO	80009	321-0222-00
A48A1R1058	315-0300-00			RES, FXD, FILM: 30 OHM, 5%, 0.25W	80009	315-0300-00
A48A1R1059	315-0300-00			RES, FXD, FILM: 30 OHM, 5%, 0.25W	80009	315-0300-00
A48A1R1063	311-1336-00			RES, VAR, NONMW: TRMR, 100K OHM, 0.75W	02111	43P104T672
A48A1R1065	311-1339-00			RES, VAR, NONMW: TRMR, 5K OHM, 0.75W	02111	43P502T672
A48A1R1067	311-1339-00			RES, VAR, NONMW: TRMR, 5K OHM, 0.75W	02111	43P502T672
A48A1R1071	311-1339-00			RES, VAR, NONMW: TRMR, 5K OHM, 0.75W	02111	43P502T672

Replaceable Electrical Parts
494A/494AP Service Vol.2

Component No.	Tektronix Part No.	Serial/Assembly No. Effective Dscnt	Name & Description	Mfr. Code	Mfr. Part No.
A48A1R1077	321-0001-00		RES,FXD,FILM:10 OHM,1%,0.125W,TC=TO	75042	CEATO-10R00F
A48A1R2019	315-0103-00		RES,FXD,FILM:10K OHM,5%,0.25W	80009	315-0103-00
A48A1R2022	315-0103-00		RES,FXD,FILM:10K OHM,5%,0.25W	80009	315-0103-00
A48A1R2035	315-0103-00		RES,FXD,FILM:10K OHM,5%,0.25W	80009	315-0103-00
A48A1R2036	315-0103-00		RES,FXD,FILM:10K OHM,5%,0.25W	80009	315-0103-00
A48A1R2038	321-0306-00		RES,FXD,FILM:15.0K OHM,1%,0.125W,TC=TO	80009	321-0306-00
A48A1R2044	321-0299-00		RES,FXD,FILM:12.7K OHM,1%,0.125W,TC=TO	80009	321-0299-00
A48A1R2046	315-0512-00		RES,FXD,FILM:5.1K OHM,5%,0.25W	80009	315-0512-00
A48A1R2048	315-0203-00		RES,FXD,FILM:20K OHM,5%,0.25W	80009	315-0203-00
A48A1R2049	315-0431-00		RES,FXD,FILM:430 OHM,5%,0.25W	80009	315-0431-00
A48A1R2050	315-0431-00		RES,FXD,FILM:430 OHM,5%,0.25W	80009	315-0431-00
A48A1R2051	315-0102-00		RES,FXD,FILM:1K OHM,5%,0.25W	80009	315-0102-00
A48A1R2053	315-0203-00		RES,FXD,FILM:20K OHM,5%,0.25W	80009	315-0203-00
A48A1R2066	308-0756-00		RES,FXD,WW:100 OHM,1%,3W	80009	308-0756-00
A48A1R2068	321-0754-07		RES,FXD,FILM:900 OHM,0.1%,0.125W,TC=T9	2M627	
A48A1R2072	321-0895-07		RES,FXD,FILM:90 OHM,0.1%,0.125W,TC=T9	80009	321-0895-07
A48A1R2074	321-0895-07		RES,FXD,FILM:90 OHM,0.1%,0.125W,TC=T9	80009	321-0895-07
A48A1R2076	321-0001-00		RES,FXD,FILM:10 OHM,1%,0.125W,TC=TO	75042	CEATO-10R00F
A48A1R3022	315-0475-00		RES,FXD,FILM:4.7M OHM,5%,0.25W	01121	CB4755
A48A1R3024	315-0105-00		RES,FXD,FILM:1M OHM,5%,0.25W	80009	315-0105-00
A48A1R3026	315-0104-00		RES,FXD,FILM:100K OHM,5%,0.25W	80009	315-0104-00
A48A1R3028	321-0306-00		RES,FXD,FILM:15.0K OHM,1%,0.125W,TC=TO	80009	321-0306-00
A48A1R3029	315-0153-00		RES,FXD,FILM:15K OHM,5%,0.25W	80009	315-0153-00
A48A1R3036	321-0289-00		RES,FXD,FILM:10.0K OHM,1%,0.125W,TC=TO	57668	FXE10K0
A48A1R3038	321-0289-00		RES,FXD,FILM:10.0K OHM,1%,0.125W,TC=TO	57668	FXE10K0
A48A1R3042	321-0299-00		RES,FXD,FILM:12.7K OHM,1%,0.125W,TC=TO	80009	321-0299-00
A48A1R3044	321-0289-00		RES,FXD,FILM:10.0K OHM,1%,0.125W,TC=TO	57668	FXE10K0
A48A1R3046	321-0299-00		RES,FXD,FILM:12.7K OHM,1%,0.125W,TC=TO	80009	321-0299-00
A48A1R3047	315-0103-00		RES,FXD,FILM:10K OHM,5%,0.25W	80009	315-0103-00
A48A1R3048	321-0289-00		RES,FXD,FILM:10.0K OHM,1%,0.125W,TC=TO	57668	FXE10K0
A48A1R4032	315-0102-00		RES,FXD,FILM:1K OHM,5%,0.25W	80009	315-0102-00
A48A1R4034	315-0102-00		RES,FXD,FILM:1K OHM,5%,0.25W	80009	315-0102-00
A48A1R4035	315-0102-00		RES,FXD,FILM:1K OHM,5%,0.25W	80009	315-0102-00
A48A1R4036	315-0103-00		RES,FXD,FILM:10K OHM,5%,0.25W	80009	315-0103-00
A48A1R4037	315-0103-00		RES,FXD,FILM:10K OHM,5%,0.25W	80009	315-0103-00
A48A1R4038	315-0103-00		RES,FXD,FILM:10K OHM,5%,0.25W	80009	315-0103-00
A48A1R4056	315-0470-00		RES,FXD,FILM:47 OHM,5%,0.25W	80009	315-0470-00
A48A1R4064	321-0001-00		RES,FXD,FILM:10 OHM,1%,0.125W,TC=TO	75042	CEATO-10R00F
A48A1R4065	321-0754-07		RES,FXD,FILM:900 OHM,0.1%,0.125W,TC=T9	2M627	
A48A1R4066	321-0895-07		RES,FXD,FILM:90 OHM,0.1%,0.125W,TC=T9	80009	321-0895-07
A48A1R5052	315-0470-00		RES,FXD,FILM:47 OHM,5%,0.25W	80009	315-0470-00
A48A1R5058	322-0043-00		RES,FXD,FILM:27.4 OHM,1%,0.25W,TC=TO	80009	322-0043-00
A48A1R5068	321-0097-00		RES,FXD,FILM:100 OHM,1%,0.125W,TC=TO	91637	CMF551166100R0F
A48A1U1025	156-0913-00		IC,DIGITAL:LSTTL,FLIP FLOP;OCTAL D-TYPE, EN ABLE;74LS377,DIP20.3,TUBE	80009	156-0913-00
A48A1U1042	156-0719-00		IC,CONVERTER:CMOS,D/A;10 BIT,800NS,CURRENT OUTPUT,MULTIPLYING;AD7533LN,DIP16.3	24355	AD7533LN
A48A1U2015	156-0913-00		IC,DIGITAL:LSTTL,FLIP FLOP;OCTAL D-TYPE, EN ABLE;74LS377,DIP20.3,TUBE	80009	156-0913-00
A48A1U2042	156-0512-00		IC,LINEAR:BIPOLAR,OP-AMP;LOW INPUT BIAS CURRENT,UNCOMPENSATED;LM308N,DIP08.3	80009	156-0512-00
A48A1U3025	156-1256-00		IC,MISC:JFET,ANALOG MUX;4-CHANNEL, WITH SHUNT DIODE & COMPENSATION FET;IH5010,DIP14.3	32293	IH5010CDD/CJD
A48A1U3032	156-0512-00		IC,LINEAR:BIPOLAR,OP-AMP;LOW INPUT BIAS CURRENT,UNCOMPENSATED;LM308N,DIP08.3	80009	156-0512-00
A48A1U3036	156-0512-00		IC,LINEAR:BIPOLAR,OP-AMP;LOW INPUT BIAS CURRENT,UNCOMPENSATED;LM308N,DIP08.3	80009	156-0512-00

Replaceable Electrical Parts
494A/494AP Service Vol.2

Component No.	Tektronix		Serial/Assembly No.		Name & Description	Mfr. Code	Mfr. Part No.
	Part No.		Effective	Discont			
A48A1U4015	156-0956-00				IC,DIGITAL:LSTTL,BUFFER/DRIVER;OCTAL NONINV , 3-STATE;74LS244,DIP20.3,TUBE	80009	156-0956-00
A48A1U4025	156-0541-00				IC,DIGITAL:LSTTL,DEMUX/DECODER;DUAL 2-TO-4 DECODER;74LS139,DIP16.3,TUBE	80009	156-0541-00
A48A1U4042	156-0140-00				IC,DIGITAL:TTL,BUFFER/DRIVER;HEX BUFFER, OC , 15V BREAKDOWN;7417,DIP14.3	01295	SN7417N
A48A1U5025	156-0469-00				IC,DIGITAL:LSTTL,DEMUX/DECODER;3-TO-8 DECODER;74LS138,DIP16.3,TUBE	80009	156-0469-00
A48A1VR1044	152-0514-00				DIODE,ZENER:;,10V,1%,0.4W;1N961D FMLY,DO-7 OR 35,TR	80009	152-0514-00
A50	119-1992-02	B010100	B010476		PHASE LOCK ASSY:	80009	119-1992-02
A50	119-1992-03	B010477			PHASE LOCK ASSY:	80009	119-1992-03
A50A1	670-5519-01				CIRCUIT BD ASSY:SYNTHESIZER	80009	670-5519-01
A50A1C1010	283-0203-00				CAP,FXD,CER DI:0.47UF,20%,50V	80009	283-0203-00
A50A1C1030	283-0032-00				CAP,FXD,CER DI:470PF,5%,500V	80009	283-0032-00
A50A1C1040	283-0177-00				CAP,FXD,CER DI:1UF,+80-20%,25V	04222	SR303E105ZAA
A50A1C2010	283-0032-00				CAP,FXD,CER DI:470PF,5%,500V	80009	283-0032-00
A50A1C2020	283-0032-00				CAP,FXD,CER DI:470PF,5%,500V	80009	283-0032-00
A50A1C2021	283-0177-00				CAP,FXD,CER DI:1UF,+80-20%,25V	04222	SR303E105ZAA
A50A1C2040	283-0032-00				CAP,FXD,CER DI:470PF,5%,500V	80009	283-0032-00
A50A1C2050	283-0177-00				CAP,FXD,CER DI:1UF,+80-20%,25V	04222	SR303E105ZAA
A50A1C2051	290-0513-00				CAP,FXD,ELCTLT:510UF,+75-10%,25V	80009	290-0513-00
A50A1C3029	283-0156-00				CAP,FXD,CER DI:1000PF,+80-20%,200V	04222	SR152E102ZAA
A50A1C3030	283-0010-00				CAP,FXD,CER DI:0.05UF,+80-20%,50V	05397	C330C503Z5U1CA
A50A1C3031	283-0032-00				CAP,FXD,CER DI:470PF,5%,500V	80009	283-0032-00
A50A1L3029	108-0311-00				COIL,RF:FIXED,150NH	TK1345	108-0311-00
A50A1Q3040	151-0188-00				TRANSISTOR,SIG:BIPOLAR,PNP;40V,200MA,250MHZ ,AMPLIFIER;2N3906,TO-92 EBC	80009	151-0188-00
A50A1Q3041	151-0188-00				TRANSISTOR,SIG:BIPOLAR,PNP;40V,200MA,250MHZ ,AMPLIFIER;2N3906,TO-92 EBC	80009	151-0188-00
A50A1R1040	315-0103-00				RES,FXD,FILM:10K OHM,5%,0.25W	80009	315-0103-00
A50A1R2040	315-0102-00				RES,FXD,FILM:1K OHM,5%,0.25W	80009	315-0102-00
A50A1R2041	315-0102-00				RES,FXD,FILM:1K OHM,5%,0.25W	80009	315-0102-00
A50A1R2042	315-0102-00				RES,FXD,FILM:1K OHM,5%,0.25W	80009	315-0102-00
A50A1R2043	315-0100-00				RES,FXD,FILM:10 OHM,5%,0.25W	19701	5043CX10RR00J
A50A1R2044	315-0100-00				RES,FXD,FILM:10 OHM,5%,0.25W	19701	5043CX10RR00J
A50A1R3020	315-0391-00				RES,FXD,FILM:390 OHM,5%,0.25W	80009	315-0391-00
A50A1R3021	315-0101-00				RES,FXD,FILM:100 OHM,5%,0.25W	80009	315-0101-00
A50A1R3022	315-0101-00				RES,FXD,FILM:100 OHM,5%,0.25W	80009	315-0101-00
A50A1R3023	315-0241-00				RES,FXD,FILM:240 OHM,5%,0.25W	80009	315-0241-00
A50A1R3040	315-0100-00				RES,FXD,FILM:10 OHM,5%,0.25W	19701	5043CX10RR00J
A50A1R3041	315-0471-00				RES,FXD,FILM:470 OHM,5%,0.25W	80009	315-0471-00
A50A1R3042	315-0471-00				RES,FXD,FILM:470 OHM,5%,0.25W	80009	315-0471-00
A50A1R3043	315-0100-00				RES,FXD,FILM:10 OHM,5%,0.25W	19701	5043CX10RR00J
A50A1R3050	315-0101-00				RES,FXD,FILM:100 OHM,5%,0.25W	80009	315-0101-00
A50A1R3051	315-0201-00				RES,FXD,FILM:200 OHM,5%,0.25W	80009	315-0201-00
A50A1U1010	156-0277-00				IC,LINEAR:BIPOLAR,VOLTAGE REGULATOR;POSITIV E,5.0V,1.0A,4%;MC7805CT,TO-220	80009	156-0277-00
A50A1U1020	156-0844-00				IC,DIGITAL:LSTTL,COUNTER;SYNCH 4-BIT BINARY ;74LS161,DIP16.3,TUBE	80009	156-0844-00
A50A1U1030	156-0844-00				IC,DIGITAL:LSTTL,COUNTER;SYNCH 4-BIT BINARY ;74LS161,DIP16.3,TUBE	80009	156-0844-00
A50A1U1040	156-0331-00				IC,DIGITAL:STTL,FLIP FLOP;DUAL D, W/SET & CLR;74S74,DIP14.3,TUBE	01295	SN74S74 N OR J
A50A1U2010	156-0844-00				IC,DIGITAL:LSTTL,COUNTER;SYNCH 4-BIT BINARY ;74LS161,DIP16.3,TUBE	80009	156-0844-00
A50A1U2020	156-0796-00				MICROCKT,DGTL:8 STG SHF & STORE BUS RGTR	80009	156-0796-00
A50A1U2030	156-0796-00				MICROCKT,DGTL:8 STG SHF & STORE BUS RGTR	80009	156-0796-00

Replaceable Electrical Parts
494A/494AP Service Vol.2

Component No.	Tektronix Part No.	Serial/Assembly No. Effective Dscont	Name & Description	Mfr. Code	Mfr. Part No.
A50A1U3030	156-0230-00		IC,DIGITAL:ECL,FLIP FLOP;DUAL D-TYPE MASTER SLAVE;10131,DIP16.3,TUBE	80009	156-0230-00
A50A2	670-9068-00		CIRCUIT BD ASSY:STROBE DRIVER	80009	670-9068-00
A50A2C1014	290-5001-00		CAP,FXD,ELCTLT:10UF,20%,16V	TK0900	ALCHIP-S16V10UF
A50A2C1030	290-5000-00		CAP,FXD,ELCTLT:1UF,20%,50V	TK0900	S50V1MICROF
A50A2C1035	283-5010-00		CAP,FXD,CER DI:0.22UF,10%,25V	80009	283-5010-00
A50A2C1036	283-5010-00		CAP,FXD,CER DI:0.22UF,10%,25V	80009	283-5010-00
A50A2C1040	283-5002-00		CAP,FXD,CER DI:1000PF,10%,50V	80009	283-5002-00
A50A2C1041	283-5003-00		CAP,FXD,CER DI:0.01UF,10%,50V	80009	283-5003-00
A50A2C1042	283-5010-00		CAP,FXD,CER DI:0.22UF,10%,25V	80009	283-5010-00
A50A2C1043	283-5010-00		CAP,FXD,CER DI:0.22UF,10%,25V	80009	283-5010-00
A50A2C1045	283-5004-00		CAP,FXD,CER DI:0.1UF,10%,25V	80009	283-5004-00
A50A2C1048	283-5001-00		CAP,FXD,CER DI:100PF,5%,50V	80009	283-5001-00
A50A2C1049	283-5001-00		CAP,FXD,CER DI:100PF,5%,50V	80009	283-5001-00
A50A2C1060	283-5000-00		CAP,FXD,CER DI:10PF,5%,50V	80009	283-5000-00
A50A2C1062	283-5000-00		CAP,FXD,CER DI:10PF,5%,50V	80009	283-5000-00
A50A2C1064	283-5004-00		CAP,FXD,CER DI:0.1UF,10%,25V	80009	283-5004-00
A50A2C1065	283-5010-00		CAP,FXD,CER DI:0.22UF,10%,25V	80009	283-5010-00
A50A2C1066	283-5010-00		CAP,FXD,CER DI:0.22UF,10%,25V	80009	283-5010-00
A50A2C1067	283-5000-00		CAP,FXD,CER DI:10PF,5%,50V	80009	283-5000-00
A50A2C1068	283-5011-00		CAP,FXD,CER DI:33PF,5%,50V	95275	VJ1206A330JXA
A50A2C2092	283-0107-00		CAP,FXD,CER DI:51PF,5%,200V	04222	SR292A510JAA
A50A2FL1024	119-1029-00		FILTER,BANDPASS:5.00674 TO 5.0188 MHZ	80009	119-1029-00
A50A2L1015	108-5003-00		COIL,RF:	54583	NL453232T-120K
A50A2L1035	108-5003-00		COIL,RF:	54583	NL453232T-120K
A50A2Q1040	151-5001-00		TRANSISTOR,SIG:BIPOLAR,NPN;40V,200MA,300MHZ ,AMPLIFIER;MMBT3904L,TO-236/SOT-23,8MM T&R	80009	151-5001-00
A50A2Q1045	151-5002-00		TRANSISTOR,SIG:JFET,N-CH;5V,75MA,60 OHM,SWI TCH;MMBF4392L,SOT-23,8MM T&R	80009	151-5002-00
A50A2R1040	321-5030-00		RES,FXD,FILM:10.0K,1%,0.125W	80009	321-5030-00
A50A2R1042	321-5003-00		RES,FXD,FILM:18.2 OHM,1%,0.125W	57668	MCR18EZHFV 18E2
A50A2R1043	321-5043-00		RES,FXD,FILM:47.5 OHM,1%,0.125W	80009	321-5043-00
A50A2R1044	321-5043-00		RES,FXD,FILM:47.5 OHM,1%,0.125W	80009	321-5043-00
A50A2R1045	321-5018-00		RES,FXD,FILM:1.00K,1%,0.125W	80009	321-5018-00
A50A2R1046	321-5008-00		RES,FXD,FILM:150 OHM,1%,0.125W	80009	321-5008-00
A50A2R1048	321-5029-00		RES,FXD,FILM:8.25K,1%,0.125W	80009	321-5029-00
A50A2R1062	321-5003-00		RES,FXD,FILM:18.2 OHM,1%,0.125W	57668	MCR18EZHFV 18E2
A50A2R1063	321-5009-00		RES,FXD,FILM:182 OHM,1%,0.125W	80009	321-5009-00
A50A2R1065	321-5000-00		RES,FXD,FILM:10 OHM,1%,0.125W	57668	MCR18EZHFV10E
A50A2R1068	321-5014-00		RES,FXD,FILM:475 OHM,1%,0.125W	80009	321-5014-00
A50A2U1015	156-5031-00		IC,DIGITAL:STTL,COUNTER;4-BIT BINARY UP/DOW N;74S169,S016.300,TUBE	80009	156-5031-00
A50A2U1035	156-5030-00		IC,DIGITAL:STTL,GATES;QUAD 2-INPUT AND;74S0 8,S014.150	80009	156-5030-00
A50A2U1036	156-0991-00		IC,LINEAR:BIPOLAR,VOLTAGE REGULATOR;POSITIV E,5.0V,100MA,5%;MC78L05ACP,TO-92	80009	156-0991-00
A50A3	670-5522-02		CIRCUIT BD ASSY:OFFSET MIXER	80009	670-5522-02
A50A3C1021	283-0203-00		CAP,FXD,CER DI:0.47UF,20%,50V	80009	283-0203-00
A50A3C1030	290-0527-00		CAP,FXD,ELCTLT:15UF,20%,20V	05397	T368B156M020AS
A50A3C1031	283-0010-00		CAP,FXD,CER DI:0.05UF,+80-20%,50V	05397	C330C503Z5U1CA
A50A3C1040	283-0203-00		CAP,FXD,CER DI:0.47UF,20%,50V	80009	283-0203-00
A50A3C1050	283-0010-00		CAP,FXD,CER DI:0.05UF,+80-20%,50V	05397	C330C503Z5U1CA
A50A3C2012	283-0010-00		CAP,FXD,CER DI:0.05UF,+80-20%,50V	05397	C330C503Z5U1CA
A50A3C2020	283-0010-00		CAP,FXD,CER DI:0.05UF,+80-20%,50V	05397	C330C503Z5U1CA
A50A3C2041	283-0010-00		CAP,FXD,CER DI:0.05UF,+80-20%,50V	05397	C330C503Z5U1CA
A50A3C2050	290-0513-00		CAP,FXD,ELCTLT:510UF,+75-10%,25V	80009	290-0513-00
A50A3CR1010	152-0322-00		DIODE,SIG:SCHTKY,;15V,410MVF AT 1MA,1.2PF;5 Q82-281i,T&R	80009	152-0322-00

Replaceable Electrical Parts
494A/494AP Service Vol.2

Component No.	Tektronix Part No.	Serial/Assembly No. Effective Dscont	Name & Description	Mfr. Code	Mfr. Part No.
A50A3CR1011	152-0322-00		DIODE,SIG:SCHTKY,;15V,410MVF AT 1MA,1.2PF;5 082-2811,T&R	80009	152-0322-00
A50A3CR2010	152-0322-00		DIODE,SIG:SCHTKY,;15V,410MVF AT 1MA,1.2PF;5 082-2811,T&R	80009	152-0322-00
A50A3CR2021	152-0322-00		DIODE,SIG:SCHTKY,;15V,410MVF AT 1MA,1.2PF;5 082-2811,T&R	80009	152-0322-00
A50A3L2020	108-0226-00		COIL,RF:FIXED,100UH	76493	84257
A50A3Q1020	151-0301-00		TRANSISTOR,SIG:BIPOLAR,PNP;60V,600MA,200MHZ ,AMPLIFIER;2N2907A,TO-18	80009	151-0301-00
A50A3Q1030	151-0301-00		TRANSISTOR,SIG:BIPOLAR,PNP;60V,600MA,200MHZ ,AMPLIFIER;2N2907A,TO-18	80009	151-0301-00
A50A3Q1040	151-0302-00		TRANSISTOR,SIG:BIPOLAR,NPN;40V,800MA,300MHZ ,AMPLIFIER;2N2222A,TO-18	80009	151-0302-00
A50A3Q2021	151-0434-00		TRANSISTOR:PNP,S1,TO-72	80009	151-0434-00
A50A3R1010	321-0068-00		RES,FXD,FILM:49.9 OHM,0.1%,0.125W,TC=TO	80009	321-0068-00
A50A3R1011	321-0068-00		RES,FXD,FILM:49.9 OHM,0.1%,0.125W,TC=TO	80009	321-0068-00
A50A3R1020	315-0202-00		RES,FXD,FILM:2K OHM,5%,0.25W	80009	315-0202-00
A50A3R1022	315-0510-00		RES,FXD,FILM:51 OHM,5%,0.25W	80009	315-0510-00
A50A3R1023	315-0101-00		RES,FXD,FILM:100 OHM,5%,0.25W	80009	315-0101-00
A50A3R1030	315-0202-00		RES,FXD,FILM:2K OHM,5%,0.25W	80009	315-0202-00
A50A3R1031	315-0432-00		RES,FXD,FILM:4.3K OHM,5%,0.25W	80009	315-0432-00
A50A3R1040	315-0511-00		RES,FXD,FILM:510 OHM,5%,0.25W	80009	315-0511-00
A50A3R1041	315-0100-00		RES,FXD,FILM:51 OHM,5%,0.25W	19701	5043CX10RROOJ
A50A3R1042	315-0102-00		RES,FXD,FILM:1K OHM,5%,0.25W	80009	315-0102-00
A50A3R1050	315-0202-00		RES,FXD,FILM:2K OHM,5%,0.25W	80009	315-0202-00
A50A3R2010	321-0068-00		RES,FXD,FILM:49.9 OHM,0.1%,0.125W,TC=TO	80009	321-0068-00
A50A3R2021	321-0068-00		RES,FXD,FILM:49.9 OHM,0.1%,0.125W,TC=TO	80009	321-0068-00
A50A3R2025	315-0471-00		RES,FXD,FILM:470 OHM,5%,0.25W	80009	315-0471-00
A50A3R2026	315-0102-00		RES,FXD,FILM:1K OHM,5%,0.25W	80009	315-0102-00
A50A3R2030	315-0510-00		RES,FXD,FILM:51 OHM,5%,0.25W	80009	315-0510-00
A50A3R2031	315-0103-00		RES,FXD,FILM:10K OHM,5%,0.25W	80009	315-0103-00
A50A3R2032	315-0510-00		RES,FXD,FILM:51 OHM,5%,0.25W	80009	315-0510-00
A50A3R2040	315-0202-00		RES,FXD,FILM:2K OHM,5%,0.25W	80009	315-0202-00
A50A3T1010	120-1011-00		TRANSFORMER,RF:TOROID	80009	120-1011-00
A50A3T2010	120-1011-00		TRANSFORMER,RF:TOROID	80009	120-1011-00
A50A3T2030	120-0459-00		XFMR,TOROID:	80009	120-0459-00
A50A3U1030	156-0991-00		IC,LINER:BIPOLAR,VOLTAGE REGULATOR;POSITIV E,5.0V,100MA,5%;MC78L05ACP,TO-92	80009	156-0991-00
A50A3U1050	156-0388-00		IC,DIGITAL:LSTTL,FLIP FLOP;DUAL D W/SET & C LR;74LS74,DIP14.3,TUBE	80009	156-0388-00
A50A3U2040	156-0991-00		IC,LINER:BIPOLAR,VOLTAGE REGULATOR;POSITIV E,5.0V,100MA,5%;MC78L05ACP,TO-92	80009	156-0991-00
A50A3U2050	156-0386-00		IC,DIGITAL:LSTTL,GATES;TRIPLE 3-INPUT NAND; 74LS10,DIP14.3,TUBE	80009	156-0386-00
A50A4	670-7921-03		CIRCUIT BD ASSY:ERROR AMPL	80009	670-7921-03
A50A4C1011	283-0204-00		CAP,FXD,CER DI:0.01UF,20%,50V	51406	RPE110Z5U103M50V
A50A4C1012	283-0204-00		CAP,FXD,CER DI:0.01UF,20%,50V	51406	RPE110Z5U103M50V
A50A4C1031	283-0177-00		CAP,FXD,CER DI:1UF,+80-20%,25V	04222	SR303E105ZAA
A50A4C1032	283-0204-00		CAP,FXD,CER DI:0.01UF,20%,50V	51406	RPE110Z5U103M50V
A50A4C1037	283-0177-00		CAP,FXD,CER DI:1UF,+80-20%,25V	04222	SR303E105ZAA
A50A4C1038	283-0339-00		CAP,FXD,CER DI:0.22UF,10%,50V	04222	SR305C224KAA
A50A4C1068	283-0177-00		CAP,FXD,CER DI:1UF,+80-20%,25V	04222	SR303E105ZAA
A50A4C1078	290-0782-00		CAP,FXD,ELCTLT:4.7UF,+75-20%,35VDC	55680	UVX1V4R7MAA
A50A4C1079	283-0032-00		CAP,FXD,CER DI:470PF,5%,500V	80009	283-0032-00
A50A4C2013	283-0204-00		CAP,FXD,CER DI:0.01UF,20%,50V	51406	RPE110Z5U103M50V
A50A4C2015	283-0204-00		CAP,FXD,CER DI:0.01UF,20%,50V	51406	RPE110Z5U103M50V
A50A4C2019	283-0204-00		CAP,FXD,CER DI:0.01UF,20%,50V	51406	RPE110Z5U103M50V
A50A4C2021	283-0032-00		CAP,FXD,CER DI:470PF,5%,500V	80009	283-0032-00

Replaceable Electrical Parts
494A/494AP Service Vol.2

Component No.	Tektronix Part No.	Serial/Assembly No. Effective Dscont	Name & Description	Mfr. Code	Mfr. Part No.
A50A4C2034	283-0177-00		CAP, FXD, CER DI: 1UF, +80-20%, 25V	04222	SR303E105ZAA
A50A4C2035	283-0204-00		CAP, FXD, CER DI: 0.01UF, 20%, 50V	51406	RPE110Z5U103M50V
A50A4C2048	283-0204-00		CAP, FXD, CER DI: 0.01UF, 20%, 50V	51406	RPE110Z5U103M50V
A50A4C2049	283-0070-00		CAP, FXD, CER DI: 30PF, 10%, 50V	51642	200-050-NPO-300K
A50A4C2059	283-0687-00		CAP, FXD, MICA DI: 560PF, 2%, 300V	80009	283-0687-00
A50A4C2060	283-0177-00		CAP, FXD, CER DI: 1UF, +80-20%, 25V	04222	SR303E105ZAA
A50A4C2061	283-0176-00		CAP, FXD, CER DI: 0.0022UF, 20%, 50V	04222	SR155C222MAA
A50A4C2062	283-0339-00		CAP, FXD, CER DI: 0.22UF, 10%, 50V	04222	SR305C224KAA
A50A4C2063	283-0330-00	B010155	CAP, FXD, CER DI: 100PF, 5%, 50V	80009	283-0330-00
A50A4C2065	283-0028-00		CAP, FXD, CER DI: 0.0022UF, 20%, 50V	80009	283-0028-00
A50A4C2067	283-0177-00		CAP, FXD, CER DI: 1UF, +80-20%, 25V	04222	SR303E105ZAA
A50A4C2069	283-0203-00		CAP, FXD, CER DI: 0.47UF, 20%, 50V	80009	283-0203-00
A50A4C2071	283-0204-00		CAP, FXD, CER DI: 0.01UF, 20%, 50V	51406	RPE110Z5U103M50V
A50A4C2072	283-0204-00		CAP, FXD, CER DI: 0.01UF, 20%, 50V	51406	RPE110Z5U103M50V
A50A4C2077	283-0339-00		CAP, FXD, CER DI: 0.22UF, 10%, 50V	04222	SR305C224KAA
A50A4C2078	283-0176-00		CAP, FXD, CER DI: 0.0022UF, 20%, 50V	04222	SR155C222MAA
A50A4C2082	290-0942-00		CAP, FXD, ELCTLT: 100UF, +100-10%, 25V	24165	672D107H025CG2C
A50A4C3010	283-0203-00		CAP, FXD, CER DI: 0.47UF, 20%, 50V	80009	283-0203-00
A50A4C3011	283-0204-00		CAP, FXD, CER DI: 0.01UF, 20%, 50V	51406	RPE110Z5U103M50V
A50A4C3044	283-0239-00		CAP, FXD, CER DI: 0.022UF, 10%, 50V	80009	283-0239-00
A50A4C3050	290-0804-00		CAP, FXD, ELCTLT: 10UF, +50-20%, 25V	80009	290-0804-00
A50A4C3051	283-0032-00		CAP, FXD, CER DI: 470PF, 5%, 500V	80009	283-0032-00
A50A4C3060	283-0177-00		CAP, FXD, CER DI: 1UF, +80-20%, 25V	04222	SR303E105ZAA
A50A4C3065	283-0115-00		CAP, FXD, CER DI: 47PF, 5%, 200V	80009	283-0115-00
A50A4CR3069	152-0141-02		DIODE, SIG: , ULTRA FAST; 40V, 150MA, 4NS, 2PF; 1N4152, DO-35, T&R	80009	152-0141-02
A50A4L3010	108-1112-00		COIL, RF: FIXED 170UH	80009	108-1112-00
A50A4L3060	108-1112-00		COIL, RF: FIXED 170UH	80009	108-1112-00
A50A4L3070	120-0382-00		COIL, RF: 210UH, +28%-43%, 14 TURNS, TEST COND. 10 KHZ, 0.115 MA.	TK1345	120-0382-00
A50A4Q2030	151-0301-00		TRANSISTOR, SIG: BIPOLAR, PNP; 60V, 600MA, 200MHZ , AMPLIFIER; 2N2907A, TO-18	80009	151-0301-00
A50A4R1011	321-0001-00		RES, FXD, FILM: 10 OHM, 1%, 0.125W, TC=TO	75042	CEATO-10R00F
A50A4R1021	315-0102-00		RES, FXD, FILM: 1K OHM, 5%, 0.25W	80009	315-0102-00
A50A4R1022	315-0102-00		RES, FXD, FILM: 1K OHM, 5%, 0.25W	80009	315-0102-00
A50A4R1023	315-0102-00		RES, FXD, FILM: 1K OHM, 5%, 0.25W	80009	315-0102-00
A50A4R1024	315-0103-00		RES, FXD, FILM: 10K OHM, 5%, 0.25W	80009	315-0103-00
A50A4R1031	315-0512-00		RES, FXD, FILM: 5.1K OHM, 5%, 0.25W	80009	315-0512-00
A50A4R1032	315-0101-00		RES, FXD, FILM: 100 OHM, 5%, 0.25W	80009	315-0101-00
A50A4R1034	321-0143-00		RES, FXD, FILM: 301 OHM, 1%, 0.125W, TC=TO	07716	CEAD301R0F
A50A4R1035	315-0101-00		RES, FXD, FILM: 100 OHM, 5%, 0.25W	80009	315-0101-00
A50A4R1037	315-0510-00		RES, FXD, FILM: 51 OHM, 5%, 0.25W	80009	315-0510-00
A50A4R1038	315-0102-00		RES, FXD, FILM: 1K OHM, 5%, 0.25W	80009	315-0102-00
A50A4R1043	315-0103-00		RES, FXD, FILM: 10K OHM, 5%, 0.25W	80009	315-0103-00
A50A4R1054	315-0510-00		RES, FXD, FILM: 51 OHM, 5%, 0.25W	80009	315-0510-00
A50A4R1061	311-1263-00		RES, VAR, NONMW: 1K OHM, 10%, 0.50W	80009	311-1263-00
A50A4R1072	315-0161-00		RES, FXD, FILM: 160 OHM, 5%, 0.25W	19701	5043CX160R0J
A50A4R1075	307-0114-00		RES, FXD, CMPSN: 6.2 OHM, 5%, 0.25W	80009	307-0114-00
A50A4R2013	315-0510-00		RES, FXD, FILM: 51 OHM, 5%, 0.25W	80009	315-0510-00
A50A4R2014	321-0001-00		RES, FXD, FILM: 10 OHM, 1%, 0.125W, TC=TO	75042	CEATO-10R00F
A50A4R2015	321-0243-00		RES, FXD, FILM: 3.32K OHM, 1%, 0.125W, TC=TO	80009	321-0243-00
A50A4R2016	321-0001-00		RES, FXD, FILM: 10 OHM, 1%, 0.125W, TC=TO	75042	CEATO-10R00F
A50A4R2017	315-0202-00		RES, FXD, FILM: 2K OHM, 5%, 0.25W	80009	315-0202-00
A50A4R2018	321-0243-00		RES, FXD, FILM: 3.32K OHM, 1%, 0.125W, TC=TO	80009	321-0243-00
A50A4R2028	315-0103-00		RES, FXD, FILM: 10K OHM, 5%, 0.25W	80009	315-0103-00
A50A4R2029	315-0102-00		RES, FXD, FILM: 1K OHM, 5%, 0.25W	80009	315-0102-00
A50A4R2031	315-0510-00		RES, FXD, FILM: 51 OHM, 5%, 0.25W	80009	315-0510-00
A50A4R2038	315-0102-00		RES, FXD, FILM: 1K OHM, 5%, 0.25W	80009	315-0102-00

Replaceable Electrical Parts
494A/494AP Service Vol.2

Component No.	Tektronix Part No.	Serial/Assembly No. Effective Dscont	Name & Description	Mfr. Code	Mfr. Part No.
A50A4R2042	321-0186-00		RES,FXD,FILM:845 OHM,1%,0.125W,TC=TO	80009	321-0186-00
A50A4R2043	315-0204-00		RES,FXD,FILM:200K OHM,5%,0.25W	80009	315-0204-00
A50A4R2048	315-0510-00		RES,FXD,FILM:51 OHM,5%,0.25W	80009	315-0510-00
A50A4R2049	315-0123-00		RES,FXD,FILM:12K OHM,5%,0.25W	80009	315-0123-00
A50A4R2051	321-0356-00		RES,FXD,FILM:49.9K OHM,1%,0.125W,TC=TO	19701	50331049K90F
A50A4R2052	321-0261-00		RES,FXD,FILM:5.11K OHM,1%,0.125W,TC=TO	80009	321-0261-00
A50A4R2061	315-0202-00		RES,FXD,FILM:2K OHM,5%,0.25W	80009	315-0202-00
A50A4R2062	315-0202-00		RES,FXD,FILM:2K OHM,5%,0.25W	80009	315-0202-00
A50A4R2066	315-0102-00		RES,FXD,FILM:1K OHM,5%,0.25W	80009	315-0102-00
A50A4R2067	315-0682-00		RES,FXD,FILM:6.8K OHM,5%,0.25W	80009	315-0682-00
A50A4R2083	321-0155-00		RES,FXD,FILM:402 OHM,1%,0.125W,TC=TO	07716	CEAD402ROF
A50A4R3010	315-0620-00		RES,FXD,FILM:62 OHM,5%,0.25W	80009	315-0620-00
A50A4R3011	307-0105-00		RES,FXD,CMPNSN:3.9 OHM,5%,0.25W	01121	CB 3965
A50A4R3046	315-0300-00		RES,FXD,FILM:30 OHM,5%,0.25W	80009	315-0300-00
A50A4R3051	321-0179-00		RES,FXD,FILM:715 OHM,1%,0.125W,TC=TO	07716	CEAD715ROF
A50A4R3052	321-0269-00		RES,FXD,FILM:6.19K OHM,1%,0.125W,TC=TO	07716	CEAD61900F
A50A4R3054	321-0180-00		RES,FXD,FILM:732 OHM,1%,0.125W,TC=TO	07716	CEAD732ROF
A50A4R3068	315-0682-00		RES,FXD,FILM:6.8K OHM,5%,0.25W	80009	315-0682-00
A50A4R3077	315-0202-00		RES,FXD,FILM:2K OHM,5%,0.25W	80009	315-0202-00
A50A4R3078	315-0202-00		RES,FXD,FILM:2K OHM,5%,0.25W	80009	315-0202-00
A50A4R3082	311-1281-00		RES,VAR,NONMW:TRMR,2.5K OHM,0.5W	80009	311-1281-00
A50A4R3083	321-0155-00		RES,FXD,FILM:402 OHM,1%,0.125W,TC=TO	07716	CEAD402ROF
A50A4U1015	156-0570-00		IC,LINEAR:BIPOLAR,COMPARATOR;DUAL,OPEN COLL ECTOR,80NS;LM319H,TO-100	TK1468	LM319H
A50A4U1035	156-1126-00		IC,LINEAR:BIPOLAR,COMPARATOR;OPEN COLLECTOR ,200NS;LM311N,DIP08.3	80009	156-1126-00
A50A4U1042	156-0991-00		IC,LINEAR:BIPOLAR,VOLTAGE REGULATOR;POSITIV E,5.0V,100MA,5%;MC78L05ACP,TO-92	80009	156-0991-00
A50A4U2025	156-0796-00		MICROCKT,DGTL:8 STG SHF & STORE BUS RGTR	80009	156-0796-00
A50A4U2037	156-1211-00		IC,MISC:BIFET,ANALOG SWITCH;QUAD;LF13333,DI P16.3	80009	156-1211-00
A50A4U2048	156-0105-00		IC,LINEAR:BIPOLAR,OP-AMP;UNCOMPENSATED;LM30 1AN,DIP08.3	TK0961	MICROPC301AC
A50A4U2065	156-0742-02		IC,LINEAR:BIPOLAR,OP-AMP;DUPLICATE OF 156-0 742-00,DO NOT USE;LM318N,DIP08.3	80009	156-0742-02
A50A4U2075	156-0277-00		IC,LINEAR:BIPOLAR,VOLTAGE REGULATOR;POSITIV E,5.0V,1.0A,4%;MC7805CT,TO-220	80009	156-0277-00
A50A4U3017	156-1160-00		IC,LINEAR:BIPOLAR,VOLTAGE REGULATOR;POSITIV E,12V,100MA,4%;LM78L12ACH,TO-39	80009	156-1160-00
A50A4U3075	156-1851-00		IC,LINEAR:BIPOLAR,OP-AMP;SINGLE,LOW NOISE;0 P27GP,DIP08.3	80009	156-1851-00
A50A4VR2065	152-0175-01		SEMICON DVC,DI-ZEN,SI,5.6V,5%,0.4W,DO-7	80009	152-0175-01
A50A4VR3047	152-0647-00		DIODE,ZENER:.;6.8V,5%,0.4W;1N957B,DO-7 OR 3 5,TR	04713	1N957B
A50A4VR3048	152-0647-00		DIODE,ZENER:.;6.8V,5%,0.4W;1N957B,DO-7 OR 3 5,TR	04713	1N957B
A50A4W1050	131-0566-00		BUS,CONDUCTOR:DUMMY RES,0.094 OD X 0.225 L	80009	131-0566-00
A50A4W2084	131-0566-00		BUS,CONDUCTOR:DUMMY RES,0.094 OD X 0.225 L	80009	131-0566-00
A50A5	670-5524-02	B010100	CIRCUIT BD ASSY:CONTROLLED OSC	80009	670-5524-02
A50A5	670-5524-03	B010477	CIRCUIT BD ASSY:CONTROLLED OSC	80009	670-5524-03
A50A5C1011	281-0810-00		CAP,FXD,CER DI:5.6PF,+/-0.5PF,100V	04222	SA101A5R6DAA
A50A5C1012	283-0260-00		CAP,FXD,CER DI:5.6PF,+/-0.25PF,200V	04222	SRI52A5R6CAA
A50A5C1013	281-0161-00		CAP,VAR,CER DI:5-15PF,350V	80009	281-0161-00
A50A5C1024	283-0204-00		CAP,FXD,CER DI:0.01UF,20%,50V	51406	RPE110Z5U103M50V
A50A5C1025	283-0204-00		CAP,FXD,CER DI:0.01UF,20%,50V	51406	RPE110Z5U103M50V
A50A5C1031	283-0204-00		CAP,FXD,CER DI:0.01UF,20%,50V	51406	RPE110Z5U103M50V
A50A5C1038	281-0622-00		CAP,FXD,CER DI:47PF,1%,500V (NOMINAL VALUE,SELECTED)	80009	281-0622-00

Replaceable Electrical Parts
494A/494AP Service Vol.2

Component No.	Tektronix Part No.	Serial/Assembly No. Effective	Discont	Name & Description	Mfr. Code	Mfr. Part No.
A50A5C1041	281-0165-00			CAP, VAR, AIR DI: 0.8-10PF, 250V	80009	281-0165-00
A50A5C1042	281-0165-00			CAP, VAR, AIR DI: 0.8-10PF, 250V	80009	281-0165-00
A50A5C1048	281-0622-00			CAP, FXD, CER DI: 47PF, 1%, 500V (NOMINAL VALUE SELECTED)	80009	281-0622-00
A50A5C2011	281-0168-00			CAP, VAR, AIR DI: 1.3-5.4PF, 250V	80009	281-0168-00
A50A5C2021	283-0346-00			CAP, FXD, CER DI: 0.47UF, +80-20%, 100V	20932	5034ES100RD474Z
A50A5C2022	290-0527-00			CAP, FXD, ELCTLT: 15UF, 20%, 20V	05397	T368B156M020AS
A50A5C2023	283-0204-00			CAP, FXD, CER DI: 0.01UF, 20%, 50V	51406	RPE110Z5U103M50V
A50A5C2034	283-0204-00			CAP, FXD, CER DI: 0.01UF, 20%, 50V	51406	RPE110Z5U103M50V
A50A5C2041	283-0204-00			CAP, FXD, CER DI: 0.01UF, 20%, 50V	51406	RPE110Z5U103M50V
A50A5C2042	283-0195-00			CAP, FXD, CER DI: 680PF, 5%, 50V	05397	C320C681J1G5CA
A50A5C2043	283-0195-00			CAP, FXD, CER DI: 680PF, 5%, 50V	05397	C320C681J1G5CA
A50A5CR1011	152-0719-00			DIODE, SIG: ,VVC; 30V, 100PF, 5%; 1N5456B, DO-7	04713	SMW1501
A50A5CR1012	152-0719-00			DIODE, SIG: ,VVC; 30V, 100PF, 5%; 1N5456B, DO-7	04713	SMW1501
A50A5L1011	108-0105-00			COIL, RF: FIXED, 1.59UH	80009	108-0105-00
A50A5L1025	108-0991-00			COIL, RF: FIXED, 800NH	80009	108-0991-00
A50A5L1035	108-0990-00			COIL, RF: FIXED, 750NH	80009	108-0990-00
A50A5L2034	108-0395-00			COIL, RF: FIXED, 64UH	80009	108-0395-00
A50A5L2043	108-0962-00			COIL, RF: FXD, 750NH	80009	108-0962-00
A50A5P1025	131-0608-00			TERMINAL, PIN: 0.365 L X 0.025 BRZ GLD PL	80009	131-0608-00
A50A5P1033	131-0608-00			TERMINAL, PIN: 0.365 L X 0.025 BRZ GLD PL	80009	131-0608-00
A50A5Q1028	151-0188-00			TRANSISTOR, SIG: B: POLAR, PNP; 40V, 200MA, 250MHZ ,AMPLIFIER; 2N3906, TO-92 EBC	80009	151-0188-00
A50A5Q2025	151-0712-01			TRANSISTOR: SELECTED	80009	151-0712-01
A50A5Q2026	151-0712-01			TRANSISTOR: SELECTED	80009	151-0712-01
A50A5Q2033	151-0712-01			TRANSISTOR: SELECTED	80009	151-0712-01
A50A5Q2041	151-0712-01			TRANSISTOR: SELECTED	80009	151-0712-01
A50A5R1024	315-0201-00			RES, FXD, FILM: 200 OHM, 5%, 0.25W	80009	315-0201-00
A50A5R1026	315-0471-00			RES, FXD, FILM: 470 OHM, 5%, 0.25W	80009	315-0471-00
A50A5R1030	315-0100-00			RES, FXD, FILM: 10 OHM, 5%, 0.25W	19701	5043CX10RR00J
A50A5R1031	315-0103-00			RES, FXD, FILM: 10K OHM, 5%, 0.25W	80009	315-0103-00
A50A5R1032	315-0390-00			RES, FXD, FILM: 39 OHM, 5%, 0.25W	80009	315-0390-00
A50A5R1033	315-0103-00			RES, FXD, FILM: 10K OHM, 5%, 0.25W	80009	315-0103-00
A50A5R2020	315-0100-00			RES, FXD, FILM: 10 OHM, 5%, 0.25W	19701	5043CX10RR00J
A50A5R2021	315-0101-00			RES, FXD, FILM: 100 OHM, 5%, 0.25W	80009	315-0101-00
A50A5R2022	315-0202-00			RES, FXD, FILM: 2K OHM, 5%, 0.25W	80009	315-0202-00
A50A5R2025	315-0182-00			RES, FXD, FILM: 1.8K OHM, 5%, 0.25W	80009	315-0182-00
A50A5R2026	321-0182-00			RES, FXD, FILM: 768 OHM, 1%, 0.125W, TC=TO	07716	CEAD768ROF
A50A5R2027	315-0101-00			RES, FXD, FILM: 100 OHM, 5%, 0.25W	80009	315-0101-00
A50A5R2031	315-0202-00			RES, FXD, FILM: 2K OHM, 5%, 0.25W	80009	315-0202-00
A50A5R2032	315-0220-00			RES, FXD, FILM: 22 OHM, 5%, 0.25W	80009	315-0220-00
A50A5R2033	315-0471-00			RES, FXD, FILM: 470 OHM, 5%, 0.25W	80009	315-0471-00
A50A5R2034	315-0101-00	B010100	B010476	RES, FXD, FILM: 100 OHM, 5%, 0.25W	80009	315-0101-00
A50A5R2034	315-0201-00	B010477		RES, FXD, FILM: 200 OHM, 5%, 0.25W	80009	315-0201-00
A50A5R2038	315-0182-00			RES, FXD, FILM: 1.8K OHM, 5%, 0.25W	80009	315-0182-00
A50A5R2041	315-0103-00	B010100	B010476	RES, FXD, FILM: 10K OHM, 5%, 0.25W	80009	315-0103-00
A50A5R2041	315-0822-00	B010477		RES, FXD, FILM: 8.2K OHM, 5%, 0.25W	80009	315-0822-00
A50A5R2042	315-0151-00			RES, FXD, FILM: 150 OHM, 5%, 0.25W	80009	315-0151-00
A50A5R2043	315-0201-00			RES, FXD, FILM: 200 OHM, 5%, 0.25W	80009	315-0201-00
A50A5U2021	156-1160-00			IC, LINEAR: BIPOLAR, VOLTAGE REGULATOR; POSITIV E, 12V, 100MA, 4%; LM78L12ACH, TO-39	80009	156-1160-00
A50A5Y2012	158-0172-00			XTAL UNIT, QTZ: 25.064 MHZ, 0.001%, SERIES	33096	CCAT101267
A51	672-0164-00			CIRCUIT BD ASSY: COUNTER	80009	672-0164-00
A51A1	670-7899-01			CIRCUIT BD ASSY: COUNTER	80009	670-7899-01
A51A1C1014	283-0156-00			CAP, FXD, CER DI: 1000PF, +80-20%, 200V	04222	SR152E102ZAA
A51A1C1016	283-0024-00			CAP, FXD, CER DI: 0.1UF, +80-20%, 50V	05397	C330C10Y25U1CA
A51A1C1038	283-0024-00			CAP, FXD, CER DI: 0.1UF, +80-20%, 50V	05397	C330C10Y25U1CA
A51A1C2010	283-0195-00			CAP, FXD, CER DI: 680PF, 5%, 50V	05397	C320C681J1G5CA

Replaceable Electrical Parts
494A/494AP Service Vol.2

Component No.	Tektronix	Serial/Assembly No.		Name & Description	Mfr.	Mfr. Part No.
	Part No.	Effective	Discont		Code	
A51A1C2034	283-0156-00			CAP, FXD, CER DI: 1000PF, +80-20%, 200V	04222	SR152E102ZAA
A51A1C2044	283-0024-00			CAP, FXD, CER DI: 0.1UF, +80-20%, 50V	05397	C330C10YZ5U1CA
A51A1C2046	283-0175-00			CAP, FXD, CER DI: 10PF, 5%, 200V	05397	C312C100D2G5CA 8
A51A1C2050	283-0156-00			CAP, FXD, CER DI: 1000PF, +80-20%, 200V	04222	SR152E102ZAA
A51A1C2052	283-0204-00			CAP, FXD, CER DI: 0.01UF, 20%, 50V	51406	RPE110Z5U103M50V
A51A1C2054	283-0204-00			CAP, FXD, CER DI: 0.01UF, 20%, 50V	51406	RPE110Z5U103M50V
A51A1C2056	283-0114-00			CAP, FXD, CER DI: 1500PF, 5%, 200V	80009	283-0114-00
A51A1C2058	283-0204-00			CAP, FXD, CER DI: 0.01UF, 20%, 50V	51406	RPE110Z5U103M50V
A51A1C2059	283-0204-00			CAP, FXD, CER DI: 0.01UF, 20%, 50V	51406	RPE110Z5U103M50V
A51A1C3010	283-0024-00			CAP, FXD, CER DI: 0.1UF, +80-20%, 50V	05397	C330C10YZ5U1CA
A51A1C3020	283-0204-00			CAP, FXD, CER DI: 0.01UF, 20%, 50V	51406	RPE110Z5U103M50V
A51A1C3050	283-0204-00			CAP, FXD, CER DI: 0.01UF, 20%, 50V	51406	RPE110Z5U103M50V
A51A1C3052	283-0204-00			CAP, FXD, CER DI: 0.01UF, 20%, 50V	51406	RPE110Z5U103M50V
A51A1C3054	283-0204-00			CAP, FXD, CER DI: 0.01UF, 20%, 50V	51406	RPE110Z5U103M50V
A51A1C3058	283-0024-00			CAP, FXD, CER DI: 0.1UF, +80-20%, 50V	05397	C330C10YZ5U1CA
A51A1C4042	290-0748-00			CAP, FXD, ELCTLT: 10UF, +50-20%, 25WVDC	24165	501D106F063LL4
A51A1CR1012	152-0322-00			DIODE, SIG: SCHKY, ;15V, 410MVF AT 1MA, 1.2PF; 5 082-2811, T&R	80009	152-0322-00
A51A1CR1030	152-0141-02			DIODE, SIG: ,ULTRA FAST; 40V, 150MA, 4NS, 2PF; 1N4 152, DO-35, T&R	80009	152-0141-02
A51A1CR1040	152-0322-00			DIODE, SIG: SCHKY, ;15V, 410MVF AT 1MA, 1.2PF; 5 082-2811, T&R	80009	152-0322-00
A51A1CR1042	152-0141-02			DIODE, SIG: ,ULTRA FAST; 40V, 150MA, 4NS, 2PF; 1N4 152, DO-35, T&R	80009	152-0141-02
A51A1CR1044	152-0141-02			DIODE, SIG: ,ULTRA FAST; 40V, 150MA, 4NS, 2PF; 1N4 152, DO-35, T&R	80009	152-0141-02
A51A1CR2040	152-0141-02			DIODE, SIG: ,ULTRA FAST; 40V, 150MA, 4NS, 2PF; 1N4 152, DO-35, T&R	80009	152-0141-02
A51A1CR2048	152-0322-00			DIODE, SIG: SCHKY, ;15V, 410MVF AT 1MA, 1.2PF; 5 082-2811, T&R	80009	152-0322-00
A51A1CR3056	152-0322-00			DIODE, SIG: SCHKY, ;15V, 410MVF AT 1MA, 1.2PF; 5 082-2811, T&R	80009	152-0322-00
A51A1CR3058	152-0322-00			DIODE, SIG: SCHKY, ;15V, 410MVF AT 1MA, 1.2PF; 5 082-2811, T&R	80009	152-0322-00
A51A1CR4040	152-0141-02			DIODE, SIG: ,ULTRA FAST; 40V, 150MA, 4NS, 2PF; 1N4 152, DO-35, T&R	80009	152-0141-02
A51A1L2056	108-0734-00			COIL, RF: FIXED, 163NH	TK1345	108-0734-00
A51A1L4016	108-0828-00			COIL, RF: FXD, 56.4UH	80009	108-0828-00
A51A1P1036	131-0265-00			CONN, RF PLUG: :SMB, PCB, MALE, RTANG, 50 OHM, 0.3 81 H X 0.150 TAIL, 0.043 DIA CTR COND, 0.040 SQ TAIL	80009	131-0265-00
A51A1P1056	131-0265-00			CONN, RF PLUG: :SMB, PCB, MALE, RTANG, 50 OHM, 0.3 81 H X 0.150 TAIL, 0.043 DIA CTR COND, 0.040 SQ TAIL	80009	131-0265-00
A51A1Q1018	151-0367-00			TRANSISTOR, SIG: BIPOLAR, NPN; 25V, 30MA, 1.0GHZ; MPS-H10 SPECIAL, TO-92 EBC	80009	151-0367-00
A51A1Q1034	151-0369-00			TRANSISTOR, SIG: BIPOLAR, PNP; 12V, 30MA, 2.0GHZ, AMPLIFIER: MPSH69, TO-92 EBC	80009	151-0369-00
A51A1Q1044	151-0369-00			TRANSISTOR, SIG: BIPOLAR, PNP; 12V, 30MA, 2.0GHZ, AMPLIFIER: MPSH69, TO-92 EBC	80009	151-0369-00
A51A1Q4034	151-0302-00			TRANSISTOR, SIG: BIPOLAR, NPN; 40V, 800MA, 300MHZ , AMPLIFIER: 2N2222A, TO-18	80009	151-0302-00
A51A1Q4052	151-0302-00			TRANSISTOR, SIG: BIPOLAR, NPN; 40V, 800MA, 300MHZ , AMPLIFIER: 2N2222A, TO-18	80009	151-0302-00
A51A1R1012	315-0472-00			RES, FXD, FILM: 4.7K OHM, 5%, 0.25W	80009	315-0472-00
A51A1R1014	315-0201-00			RES, FXD, FILM: 200 OHM, 5%, 0.25W	80009	315-0201-00
A51A1R1016	315-0102-00			RES, FXD, FILM: 1K OHM, 5%, 0.25W	80009	315-0102-00
A51A1R1020	317-0103-00			RES, FXD, CMPSN: 10K OHM, 5%, 0.125W	80009	317-0103-00

Replaceable Electrical Parts
494A/494AP Service Vol.2

Component No.	Tektronix		Serial/Assembly No.		Name & Description	Mfr. Code	Mfr. Part No.
	Part No.	Effective	Discont.				
A51A1R1021	317-0103-00				RES, FXD, CMPSN: 10K OHM, 5%, 0.125W	80009	317-0103-00
A51A1R1030	315-0271-00				RES, FXD, FILM: 270 OHM, 5%, 0.25W	80009	315-0271-00
A51A1R1032	315-0512-00				RES, FXD, FILM: 5.1K OHM, 5%, 0.25W	80009	315-0512-00
A51A1R1034	315-0102-00				RES, FXD, FILM: 1K OHM, 5%, 0.25W	80009	315-0102-00
A51A1R1042	315-0271-00				RES, FXD, FILM: 270 OHM, 5%, 0.25W	80009	315-0271-00
A51A1R1044	315-0751-00				RES, FXD, FILM: 750 OHM, 5%, 0.25W	80009	315-0751-00
A51A1R1046	315-0103-00				RES, FXD, FILM: 10K OHM, 5%, 0.25W	80009	315-0103-00
A51A1R1056	315-0101-00				RES, FXD, FILM: 100 OHM, 5%, 0.25W	80009	315-0101-00
A51A1R2022	315-0561-00				RES, FXD, FILM: 560 OHM, 5%, 0.25W	80009	315-0561-00
A51A1R2030	315-0512-00				RES, FXD, FILM: 5.1K OHM, 5%, 0.25W	80009	315-0512-00
A51A1R2032	315-0681-00				RES, FXD, FILM: 680 OHM, 5%, 0.25W	80009	315-0681-00
A51A1R2034	315-0122-00				RES, FXD, FILM: 1.2K OHM, 5%, 0.25W	80009	315-0122-00
A51A1R2036	315-0301-00				RES, FXD, FILM: 300 OHM, 5%, 0.25W	80009	315-0301-00
A51A1R2038	315-0101-00				RES, FXD, FILM: 100 OHM, 5%, 0.25W	80009	315-0101-00
A51A1R2042	315-0681-00				RES, FXD, FILM: 680 OHM, 5%, 0.25W	80009	315-0681-00
A51A1R2044	315-0122-00				RES, FXD, FILM: 1.2K OHM, 5%, 0.25W	80009	315-0122-00
A51A1R3010	315-0102-00				RES, FXD, FILM: 1K OHM, 5%, 0.25W	80009	315-0102-00
A51A1R3012	315-0361-00				RES, FXD, FILM: 360 OHM, 5%, 0.25W	80009	315-0361-00
A51A1R3030	315-0512-00				RES, FXD, FILM: 5.1K OHM, 5%, 0.25W	80009	315-0512-00
A51A1R3034	315-0512-00				RES, FXD, FILM: 5.1K OHM, 5%, 0.25W	80009	315-0512-00
A51A1R3044	315-0512-00				RES, FXD, FILM: 5.1K OHM, 5%, 0.25W	80009	315-0512-00
A51A1R3048	315-0153-00				RES, FXD, FILM: 15K OHM, 5%, 0.25W	80009	315-0153-00
A51A1R3052	315-0821-00				RES, FXD, FILM: 820 OHM, 5%, 0.25W	80009	315-0821-00
A51A1R3054	315-0101-00				RES, FXD, FILM: 100 OHM, 5%, 0.25W	80009	315-0101-00
A51A1R3056	315-0242-00				RES, FXD, FILM: 2.4K OHM, 5%, 0.25W	80009	315-0242-00
A51A1R3058	315-0202-00				RES, FXD, FILM: 2K OHM, 5%, 0.25W	80009	315-0202-00
A51A1R4010	315-0561-00				RES, FXD, FILM: 560 OHM, 5%, 0.25W	80009	315-0561-00
A51A1R4018	315-0472-00				RES, FXD, FILM: 4.7K OHM, 5%, 0.25W	80009	315-0472-00
A51A1R4020	315-0472-00				RES, FXD, FILM: 4.7K OHM, 5%, 0.25W	80009	315-0472-00
A51A1R4028	307-0696-00				RES NTK, FXD, FI: 7.10K OHM, 2%, 0.15W EACH	80009	307-0696-00
A51A1R4036	315-0472-00				RES, FXD, FILM: 4.7K OHM, 5%, 0.25W	80009	315-0472-00
A51A1R4038	315-0103-00				RES, FXD, FILM: 10K OHM, 5%, 0.25W	80009	315-0103-00
A51A1R4050	315-0103-00				RES, FXD, FILM: 10K OHM, 5%, 0.25W	80009	315-0103-00
A51A1R4052	315-0103-00				RES, FXD, FILM: 10K OHM, 5%, 0.25W	80009	315-0103-00
A51A1U1018	156-0994-00				IC, DIGITAL: LSTTL, MUX/ENCODER; 8-TO-1, T&F OU TPUTS; 74LS151, DIP16.3, TUBE	80009	156-0994-00
A51A1U1022	156-0796-00				MICROCKT, DGTL: 8 STG SHF & STORE BUS RGTR	80009	156-0796-00
A51A1U1028	156-1172-00				IC, DIGITAL: LSTTL, COUNTER; DUAL 4-BIT BINARY; 74LS393, DIP14.3, TUBE	80009	156-1172-00
A51A1U1038	156-0230-00				IC, DIGITAL: ECL, FLIP FLOP; DUAL D-TYPE MASTER SLAVE; 10131, DIP16.3, TUBE	80009	156-0230-00
A51A1U1046	156-0994-00				IC, DIGITAL: LSTTL, MUX/ENCODER; 8-TO-1, T&F OU TPUTS; 74LS151, DIP16.3, TUBE	80009	156-0994-00
A51A1U1050	156-1172-00				IC, DIGITAL: LSTTL, COUNTER; DUAL 4-BIT BINARY; 74LS393, DIP14.3, TUBE	80009	156-1172-00
A51A1U2010	156-1172-00				IC, DIGITAL: LSTTL, COUNTER; DUAL 4-BIT BINARY; 74LS393, DIP14.3, TUBE	80009	156-1172-00
A51A1U2018	156-1183-00				IC, DIGITAL: STTL, COUNTER; 4-BIT BINARY OR DEC ADE W/LATCH; 74S197, DIP14.3	01295	SN74S197N
A51A1U2026	156-0914-00				IC, DIGITAL: LSTTL, BUFFER/DRIVER; OCTAL INV, 3 -STATE; 74LS240, DIP20.3, TUBE	80009	156-0914-00
A51A1U2030	156-0729-01	B010100	B010353		IC, DIGITAL: 3 STATE HEX, SCREENED	27014	DM80L98N/A+
A51A1U2030	156-0720-00	B010354			IC, DIGITAL: LSTTL, GATES; HEX INV, BUS DRIVER, 3-STATE; 74LS368, DIP16.3, TUBE	01295	SN74LS368AN
A51A1U2034	156-1172-00				IC, DIGITAL: LSTTL, COUNTER; DUAL 4-BIT BINARY; 74LS393, DIP14.3, TUBE	80009	156-1172-00
A51A1U2040	156-0469-00				IC, DIGITAL: LSTTL, DEMUX/DECODER; 3-TO-8 DECOD ER; 74LS138, DIP16.3, TUBE	80009	156-0469-00

Replaceable Electrical Parts
494A/494AP Service Vol.2

Component No.	Tektronix Part No.	Serial/Assembly No. Effective	Discont	Name & Description	Mfr. Code	Mfr. Part No.
A51A1U2046	156-0331-00			IC,DIGITAL:STTL,FLIP FLOP;DUAL D, W/SET & C LR;74S74,DIP14.3,TUBE	01295	SN74S74 N OR J
A51A1U2050	156-1172-00			IC,DIGITAL:LSSTL,COUNTER;DUAL 4-BIT BINARY; 74LS393,DIP14.3,TUBE	80009	156-1172-00
A51A1U2056	156-0902-00			MICROCKT,DGTL:FM IF AMPL	04713	MC1355P
A51A1U3010	156-0383-00			IC,DIGITAL:LSSTL,GATES;QUAD 2-INPUT NOR;74L 502,DIP14.3,TUBE	80009	156-0383-00
A51A1U3018	156-0799-00			IC,DIGITAL:	04713	MC14017BCL
A51A1U3024	156-0914-00			IC,DIGITAL:LSSTL,BUFFER/DRIVER;OCTAL INV, 3 -STATE;74LS240,DIP20.3,TUBE	80009	156-0914-00
A51A1U3030	156-0914-00			IC,DIGITAL:LSSTL,BUFFER/DRIVER;OCTAL INV, 3 -STATE;74LS240,DIP20.3,TUBE	80009	156-0914-00
A51A1U3034	156-0914-00			IC,DIGITAL:LSSTL,BUFFER/DRIVER;OCTAL INV, 3 -STATE;74LS240,DIP20.3,TUBE	80009	156-0914-00
A51A1U3040	156-0798-00			IC,DIGITAL:LSSTL,MUX/ENCODER;DUAL 4-TO-1;74 LS153,DIP16.3,TUBE	80009	156-0798-00
A51A1U3046	156-0385-00			IC,DIGITAL:LSSTL,GATES;HEX INV;74LS04,DIP14 .3,TUBE	80009	156-0385-00
A51A1U3048	156-0366-00			IC,DIGITAL:CMOS,FLIP FLOP;DUAL D-TYPE;4013B ,DIP14.3,TUBE	80009	156-0366-00
A51A1U4056	156-1172-00			IC,DIGITAL:LSSTL,COUNTER;DUAL 4-BIT BINARY; 74LS393,DIP14.3,TUBE	80009	156-1172-00
A54	670-9680-00	B010100	B010164	CIRCUIT BD ASSY:MEMORY	80009	670-9680-00
A54	670-9680-01	B010165	B010216	CIRCUIT BD ASSY:MEMORY	80009	670-9680-01
A54	670-9680-02	B010217	B020700	CIRCUIT BD ASSY:MEMORY	80009	670-9680-02
A54	671-2124-00	B020701		CIRCUIT BD ASSY:MEMORY;;388-9200-XX WIRED	80009	671-2124-00
A54	670-9950-00	B010100	B010215	CIRCUIT BD ASSY:MEMORY	80009	670-9950-00
A54	670-9950-01	B010216	B010216	CIRCUIT BD ASSY:MEMORY	80009	670-9950-01
A54	670-9950-02	B010217	B010238	CIRCUIT BD ASSY:MEMORY (OPTION 39 ONLY)	80009	670-9950-02
A54	671-2125-00	B010239		CIRCUIT BD ASSY:MEMORY;;388-9200-XX WIRED,0 PT 39	80009	671-2125-00
A54	671-0029-00	B010100	B010502	CIRCUIT BD ASSY:MEMORY	80009	671-0029-00
A54	671-0029-01	B010503		CIRCUIT BD ASSY:MEMORY (OPTION 45 ONLY)	80009	671-0029-01
A54BT2040	146-0044-00			BATTERY,DRY:3V,0.17AH @ 0.85MA,BUTTON CELL, LITHIUM-MANGANESE DIOXIDE	00681	ORDER BY DESCR
A54BT2040	146-0057-00			BATTERY,DRY:1.5V NOMINAL (OPTION 39 ONLY)	1F809	392BP
A54BT2041	146-0057-00			BATTERY,DRY:1.5V NOMINAL (OPTION 39 ONLY)	1F809	392BP
A54BT2042	146-0057-00			BATTERY,DRY:1.5V NOMINAL (OPTION 39 ONLY)	1F809	392BP
A54C1010	283-5004-00			CAP,FXD,CER DI:0.1UF,10%,25V	80009	283-5004-00
A54C1020	283-5004-00			CAP,FXD,CER DI:0.1UF,10%,25V	80009	283-5004-00
A54C1030	283-5004-00			CAP,FXD,CER DI:0.1UF,10%,25V	80009	283-5004-00
A54C1034	290-5001-00			CAP,FXD,ELCLTLT:10UF,20%,16V	TK0900	ALCHIP-S16V10UF
A54C2020	283-5004-00			CAP,FXD,CER DI:0.1UF,10%,25V	80009	283-5004-00
A54C2030	290-5001-00			CAP,FXD,ELCLTLT:10UF,20%,16V	TK0900	ALCHIP-S16V10UF
A54C2040	283-5004-00			CAP,FXD,CER DI:0.1UF,10%,25V	80009	283-5004-00
A54C2050	283-5004-00			CAP,FXD,CER DI:0.1UF,10%,25V	80009	283-5004-00
A54C2054	283-5004-00			CAP,FXD,CER DI:0.1UF,10%,25V	80009	283-5004-00
A54C2056	283-5004-00			CAP,FXD,CER DI:0.1UF,10%,25V	80009	283-5004-00
A54C2060	283-5004-00			CAP,FXD,CER DI:0.1UF,10%,25V	80009	283-5004-00
A54C3020	283-5004-00			CAP,FXD,CER DI:0.1UF,10%,25V	80009	283-5004-00
A54C3030	283-5004-00			CAP,FXD,CER DI:0.1UF,10%,25V	80009	283-5004-00
A54C3034	283-5004-00			CAP,FXD,CER DI:0.1UF,10%,25V	80009	283-5004-00
A54C3040	283-5004-00			CAP,FXD,CER DI:0.1UF,10%,25V	80009	283-5004-00
A54C3042	283-5004-00			CAP,FXD,CER DI:0.1UF,10%,25V	80009	283-5004-00
A54C3046	283-5004-00			CAP,FXD,CER DI:0.1UF,10%,25V	80009	283-5004-00

Replaceable Electrical Parts
494A/494AP Service Vol.2

Component No.	Tektronix Part No.	Serial/Assembly No. Effective	Discont	Name & Description	Mfr. Code	Mfr. Part No.
A54C4050	290-5001-00			CAP, FXD, ELCTLT: 10UF, 20%, 16V	TK0900	ALCHIP-S16V10UF
A54CR1030	152-5001-00			DIODE, SIG: SCHKY, ; 50V, 1.5PF, 0.6VF; MMBD701L, SOT-23, 8MM TR	80009	152-5001-00
A54CR2020	152-5000-00			SEMICON DVC, DI: SW, SI, 70V, COM CATHODE	80009	152-5000-00
A54CR2024	152-5000-00			SEMICON DVC, DI: SW, SI, 70V, COM CATHODE	80009	152-5000-00
A54CR2030	152-5000-00			SEMICON DVC, DI: SW, SI, 70V, COM CATHODE	80009	152-5000-00
A54CR3030	152-5001-00			DIODE, SIG: SCHKY, ; 50V, 1.5PF, 0.6VF; MMBD701L, SOT-23, 8MM TR	80009	152-5001-00
A54L4040	108-0836-00			COIL, RF: FIXED, 14UH	80009	108-0836-00
A54Q2025	151-5001-00			TRANSISTOR, SIG: BIPOLAR, NPN; 40V, 200MA, 300MHZ, AMPLIFIER; MMBT3904L, TO-236/SOT-23, 8MM T&R	80009	151-5001-00
A54Q2030	151-5001-00			TRANSISTOR, SIG: BIPOLAR, NPN; 40V, 200MA, 300MHZ, AMPLIFIER; MMBT3904L, TO-236/SOT-23, 8MM T&R	80009	151-5001-00
A54Q2035	151-5001-00			TRANSISTOR, SIG: BIPOLAR, NPN; 40V, 200MA, 300MHZ, AMPLIFIER; MMBT3904L, TO-236/SOT-23, 8MM T&R	80009	151-5001-00
A54Q2037	151-5000-00			TRANSISTOR, SIG: BIPOLAR, PNP; 40V, 200MA, 250MHZ, AMPLIFIER; MMBT3906L, TO-236/SOT-23, 8MM T&R	04713	MMBT3906LT1
A54R1030	321-5014-00			RES, FXD, FILM: 475 OHM, 1%, 0.125W	80009	321-5014-00
A54R1046	321-5030-00			RES, FXD, FILM: 10.0K, 1%, 0.125W	80009	321-5030-00
A54R1048	321-5030-00			RES, FXD, FILM: 10.0K, 1%, 0.125W	80009	321-5030-00
A54R1050	321-5030-00			RES, FXD, FILM: 10.0K, 1%, 0.125W	80009	321-5030-00
A54R1051	321-5030-00			RES, FXD, FILM: 10.0K, 1%, 0.125W	80009	321-5030-00
A54R1052	321-5030-00			RES, FXD, FILM: 10.0K, 1%, 0.125W	80009	321-5030-00
A54R1054	321-5030-00			RES, FXD, FILM: 10.0K, 1%, 0.125W	80009	321-5030-00
A54R1056	321-5030-00			RES, FXD, FILM: 10.0K, 1%, 0.125W	80009	321-5030-00
A54R1057	321-5030-00			RES, FXD, FILM: 10.0K, 1%, 0.125W	80009	321-5030-00
A54R1058	321-5030-00			RES, FXD, FILM: 10.0K, 1%, 0.125W	80009	321-5030-00
A54R2020	321-5026-00			RES, FXD, FILM: 4.75K, 1%, 0.125W	80009	321-5026-00
A54R2026	321-5030-00			RES, FXD, FILM: 10.0K, 1%, 0.125W	80009	321-5030-00
A54R2032	321-5030-00			RES, FXD, FILM: 10.0K, 1%, 0.125W	80009	321-5030-00
A54R2033	321-5018-00			RES, FXD, FILM: 1.00K, 1%, 0.125W	80009	321-5018-00
A54R2034	321-5047-00			RES, FXD, FILM: 100K, 1%, 0.125W	80009	321-5047-00
A54R2035	321-5039-00			RES, FXD, FILM: 56.2K, 1%, 0.125W	80009	321-5039-00
A54R2036	321-5030-00			RES, FXD, FILM: 10.0K, 1%, 0.125W	80009	321-5030-00
A54R2037	321-5015-00			RES, FXD, FILM: 562 OHM, 1%, 0.125W	80009	321-5015-00
A54R2038	321-5018-00			RES, FXD, FILM: 1.00K, 1%, 0.125W	80009	321-5018-00
A54R3030	321-5006-00			RES, FXD, FILM: 100 OHM, 1%, 0.125W	80009	321-5006-00
A54R3032	321-5006-00			RES, FXD, FILM: 10.0K, 1%, 0.125W	80009	321-5030-00
A54R3034	321-5030-00			RES, FXD, FILM: 10.0K, 1%, 0.125W	80009	321-5030-00
A54S1050	260-1721-00			SWITCH, ROCKER: 8, SPST, 125MA, 30VDC	81073	765B08S
A54U1010	156-1842-00			IC, MEMORY: CMOS, SRAM; 8K X 8, 150NS, OE; , DIP28. 6	80009	156-1842-00
A54U1020	156-2473-00			IC, MEMORY: CMOS, SRAM; 8K X 8, 200NS, 10UA, OE; , DIP28. 6	80009	156-2473-00
A54U1030	156-2473-00			IC, MEMORY: CMOS, SRAM; 8K X 8, 200NS, 10UA, OE; , DIP28. 6	80009	156-2473-00
A54U2040	156-5001-00			IC, DIGITAL: LSTTL, GATES; QUAD 2-INPUT NAND; 74LS00, S014.150, TUBE	01295	SN74LS00D
A54U2045	156-5005-00			IC, DIGITAL: LSTTL, DEMUX/DECODER; DUAL 2-TO-4 DECODER; 74LS139, S016.150, TUBE	80009	156-5005-00
A54U2050	156-5034-00			IC, DIGITAL: LSTTL, BUFFER; NONINV, OCTAL, LINE DRIVER, 3-STATE; 74LS244, S020.300, TUBE	80009	156-5034-00
A54U3020	156-1842-00			IC, MEMORY: CMOS, SRAM; 8K X 8, 150NS, OE; , DIP28. 6	80009	156-1842-00
A54U3025	156-5005-00			IC, DIGITAL: LSTTL, DEMUX/DECODER; DUAL 2-TO-4 DECODER; 74LS139, S016.150, TUBE	80009	156-5005-00
A54U3030	156-5032-00			IC, DIGITAL: LSTTL, GATES; QUAD 2-INPUT NOR; 74LS02, S014.150, TUBE	80009	156-5032-00

Replaceable Electrical Parts
494A/494AP Service Vol.2

Component No.	Tektronix Part No.	Serial/Assembly No. Effective	Discont	Name & Description	Mfr. Code	Mfr. Part No.
A54U3040	156-5033-00			IC, DIGITAL: LSTTL, DEMUX/DECODER; 3-TO-8 DECODER; 74LS138, SO16.150, TUBE	80009	156-5033-00
A54U3045	156-5033-00			IC, DIGITAL: LSTTL, DEMUX/DECODER; 3-TO-8 DECODER; 74LS138, SO16.150, TUBE	80009	156-5033-00
A54U3050	160-3691-00	B010100	B010181	MICROCKT, DGTL: NMOS, 32 X 8 EPROM, PRGM	80009	160-3691-00
A54U3050	160-3691-02	B010182	B010209	MICROCKT, DGTL: NMOS, 32 X 8 EPROM, PRGM	80009	160-3691-02
A54U3050	160-3691-03	B010210	B010215	MICROCKT, DGTL: NMOS, 32 X 8 EPROM, PRGM	80009	160-3691-03
A54U3050	160-3691-04	B010216	B010216	MICROCKT, DGTL: NMOS, 32 X 8 EPROM, PRGM	80009	160-3691-04
A54U3050	160-3691-05	B010217	B020700	MICROCKT, DGTL: NMOS, 32 X 8 EPROM, PRGM	80009	160-3691-05
A54U3050	160-8315-00	B020701		MICROCKT, DGTL: NMOS, 32 X 8 EPROM, PRGM; ; D2725 6-3, DIP28	80009	160-8315-00
A54U3050	160-4487-00	B010100	B010502	MICROCKT, DGTL: NMOS, 32 X 8 EPROM, PRGM	80009	160-4487-00
A54U3050	160-4487-01	B010503		MICROCKT, DGTL: NMOS, 32 X 8 EPROM, PRGM (OPTION 45 ONLY)	80009	160-4487-01
A54U3060	160-3692-00	B010100	B010181	MICROCKT, DGTL: NMOS, 32 X 8 EPROM, PRGM	80009	160-3692-00
A54U3060	160-3692-02	B010182	B010209	MICROCKT, DGTL: NMOS, 32 X 8 EPROM, PRGM	80009	160-3692-02
A54U3060	160-3692-03	B010210	B010215	MICROCKT, DGTL: NMOS, 32 X 8 EPROM, PRGM	80009	160-3692-03
A54U3060	160-3692-04	B010216	B010216	MICROCKT, DGTL: NMOS, 32 X 8 EPROM, PRGM	80009	160-3692-04
A54U3060	160-3692-05	B010217	B020700	MICROCKT, DGTL: NMOS, 32 X 8 EPROM, PRGM	80009	160-3692-05
A54U3060	160-8316-00	B020701		MICROCKT, DGTL: NMOS, 32 X 8 EPROM, PRGM; ; D2725 6-3, DIP28	80009	160-8316-00
A54U3060	160-4488-00	B010100	B010502	MICROCKT, DGTL: NMOS, 32 X 8 EPROM, PRGM	80009	160-4488-00
A54U3060	160-4488-01	B010503		MICROCKT, DGTL: NMOS, 32 X 8 EPROM, PRGM (OPTION 45 ONLY)	80009	160-4488-01
A54U4020	156-5009-00			IC, DIGITAL: LSTTL, FLIP FLOP; OCTAL D-TYPE, CLEAR; 74LS273, SO20.300, TUBE	80009	156-5009-00
A54U4030	156-5003-00			IC, DIGITAL: LSTTL, FLIP FLOP; DUAL D-TYPE; 74LS74, SO14.150, TUBE	01295	SN74LS74D
A54U4040	156-5033-00			IC, DIGITAL: LSTTL, DEMUX/DECODER; 3-TO-8 DECODER; 74LS138, SO16.150, TUBE	80009	156-5033-00
A54W1030	321-5051-00			RES, FXD, FILM: 0 OHM, 1%, 0.125W	80009	321-5051-00
A56	670-9770-00	B010100	B010215	CIRCUIT BD ASSY: GPIB	80009	670-9770-00
A56	670-9770-01	B010216	B010216	CIRCUIT BD ASSY: GPIB	80009	670-9770-01
A56	670-9770-02	B010217	B020700	CIRCUIT BD ASSY: GPIB	80009	670-9770-02
A56	671-2123-00	B020701	B020764	CIRCUIT BD ASSY: GPIB; ; 388-9263-XX WIRED	80009	671-2123-00
A56	671-2123-01	B020765		CIRCUIT BD ASSY: GPIB; ; 388-9263-XX WIRED	80009	671-2123-01
A56	671-0030-00	B010100	B010502	CIRCUIT BD ASSY: GPIB	80009	671-0030-00
A56	671-0030-01	B010503	B020764	CIRCUIT BD ASSY: GPIB	80009	671-0030-01
A56	671-0030-02	B020765		CIRCUIT BD ASSY: GPIB; ; 388-9263-XX WIRED (OPTION 45 ONLY)	80009	671-0030-02
A56C1045	283-5004-00			CAP, FXD, CER DI: 0.1UF, 10%, 25V	80009	283-5004-00
A56C1056	290-5001-00	B010100	B020764	CAP, FXD, ELCTLT: 10UF, 20%, 16V	TK0900	ALCHIP-S16V10UF
A56C1056	290-5039-00	B020765		CAP, FXD, ALUM: 10UF, 20%, 50V, 6.3MM, SMD, 16MM TAPE & REEL	80009	290-5039-00
A56C1064	283-5004-00			CAP, FXD, CER DI: 0.1UF, 10%, 25V	80009	283-5004-00
A56C1074	283-5004-00			CAP, FXD, CER DI: 0.1UF, 10%, 25V	80009	283-5004-00
A56C1085	283-5004-00			CAP, FXD, CER DI: 0.1UF, 10%, 25V	80009	283-5004-00
A56C1088	283-5004-00			CAP, FXD, CER DI: 0.1UF, 10%, 25V	80009	283-5004-00
A56C1094	283-5004-00			CAP, FXD, CER DI: 0.1UF, 10%, 25V	80009	283-5004-00
A56C1099	283-5004-00			CAP, FXD, CER DI: 0.1UF, 10%, 25V	80009	283-5004-00
A56C1106	283-5004-00			CAP, FXD, CER DI: 0.1UF, 10%, 25V	80009	283-5004-00
A56C2057	283-5004-00			CAP, FXD, CER DI: 0.1UF, 10%, 25V	80009	283-5004-00
A56C2074	283-5004-00			CAP, FXD, CER DI: 0.1UF, 10%, 25V	80009	283-5004-00
A56C2075	283-5004-00			CAP, FXD, CER DI: 0.1UF, 10%, 25V	80009	283-5004-00
A56C2076	283-5004-00			CAP, FXD, CER DI: 0.1UF, 10%, 25V	80009	283-5004-00
A56C2077	283-5004-00			CAP, FXD, CER DI: 0.1UF, 10%, 25V	80009	283-5004-00
A56C2078	283-5004-00			CAP, FXD, CER DI: 0.1UF, 10%, 25V	80009	283-5004-00
A56C2084	283-5004-00			CAP, FXD, CER DI: 0.1UF, 10%, 25V	80009	283-5004-00
A56C2095	283-5004-00			CAP, FXD, CER DI: 0.1UF, 10%, 25V	80009	283-5004-00
A56C2105	283-5004-00			CAP, FXD, CER DI: 0.1UF, 10%, 25V	80009	283-5004-00

Replaceable Electrical Parts
494A/494AP Service Vol.2

Component No.	Tektronix Part No.	Serial/Assembly No. Effective	Discont	Name & Description	Mfr. Code	Mfr. Part No.
A56C2107	283-5004-00			CAP, FXD, CER DI: 0.1UF, 10%, 25V	80009	283-5004-00
A56C3072	283-5004-00			CAP, FXD, CER DI: 0.1UF, 10%, 25V	80009	283-5004-00
A56C3074	283-5004-00			CAP, FXD, CER DI: 0.1UF, 10%, 25V	80009	283-5004-00
A56C3075	283-5004-00			CAP, FXD, CER DI: 0.1UF, 10%, 25V	80009	283-5004-00
A56C3076	283-5004-00			CAP, FXD, CER DI: 0.1UF, 10%, 25V	80009	283-5004-00
A56C4051	290-5001-00	B010100	B020764	CAP, FXD, ELCTLT: 10UF, 20%, 16V	TK0900	ALCHIP-S16V10UF
A56C4051	290-5039-00	B020765		CAP, FXD, ALUM: 10UF, 20%, 50V, 6.3MM, SMD, 16MM TA PE & REEL.	80009	290-5039-00
A56DS1047	150-1068-00			LT EMITTING DIO: RED, 635NM, 10MA MAX	80009	150-1068-00
A56DS1048	150-1068-00			LT EMITTING DIO: RED, 635NM, 10MA MAX	80009	150-1068-00
A56DS1049	150-1068-00			LT EMITTING DIO: RED, 635NM, 10MA MAX	80009	150-1068-00
A56DS1050	150-1068-00			LT EMITTING DIO: RED, 635NM, 10MA MAX	80009	150-1068-00
A56DS1052	150-1068-00			LT EMITTING DIO: RED, 635NM, 10MA MAX	80009	150-1068-00
A56DS1053	150-1068-00			LT EMITTING DIO: RED, 635NM, 10MA MAX	80009	150-1068-00
A56DS1054	150-1068-00			LT EMITTING DIO: RED, 635NM, 10MA MAX	80009	150-1068-00
A56J566	131-3823-00			CONN, HDR: PCB, ; MALE, RTANG, 2 X 13, 0.1 CTR, 0.3 3 H X 0.112 TAIL, SHRD/4 SIDES, 30 GOLD; ..	53387	3593-5002
A56L4048	108-0836-00			COIL, RF: FIXED, 14UH	80009	108-0836-00
A56R1042	321-5030-00			RES, FXD, FILM: 10.0K, 1%, 0.125W	80009	321-5030-00
A56R1043	321-5030-00			RES, FXD, FILM: 10.0K, 1%, 0.125W	80009	321-5030-00
A56R2044	321-5013-00			RES, FXD, FILM: 392 OHM, 1%, 0.125W	80009	321-5013-00
A56R2045	321-5013-00			RES, FXD, FILM: 392 OHM, 1%, 0.125W	80009	321-5013-00
A56R2046	321-5013-00			RES, FXD, FILM: 392 OHM, 1%, 0.125W	80009	321-5013-00
A56R2047	321-5013-00			RES, FXD, FILM: 392 OHM, 1%, 0.125W	80009	321-5013-00
A56R2072	321-5030-00			RES, FXD, FILM: 10.0K, 1%, 0.125W	80009	321-5030-00
A56R2075	321-5030-00			RES, FXD, FILM: 10.0K, 1%, 0.125W	80009	321-5030-00
A56R2076	321-5030-00			RES, FXD, FILM: 10.0K, 1%, 0.125W	80009	321-5030-00
A56R2077	321-5030-00			RES, FXD, FILM: 10.0K, 1%, 0.125W	80009	321-5030-00
A56R2078	321-5030-00			RES, FXD, FILM: 10.0K, 1%, 0.125W	80009	321-5030-00
A56R3041	321-5013-00			RES, FXD, FILM: 392 OHM, 1%, 0.125W	80009	321-5013-00
A56R3042	321-5013-00			RES, FXD, FILM: 392 OHM, 1%, 0.125W	80009	321-5013-00
A56R3043	321-5013-00			RES, FXD, FILM: 392 OHM, 1%, 0.125W	80009	321-5013-00
A56R3074	321-5030-00			RES, FXD, FILM: 10.0K, 1%, 0.125W	80009	321-5030-00
A56R3075	321-5030-00			RES, FXD, FILM: 10.0K, 1%, 0.125W	80009	321-5030-00
A56R3076	321-5030-00			RES, FXD, FILM: 10.0K, 1%, 0.125W	80009	321-5030-00
A56R3077	321-5030-00			RES, FXD, FILM: 10.0K, 1%, 0.125W	80009	321-5030-00
A56R3086	321-5030-00			RES, FXD, FILM: 10.0K, 1%, 0.125W	80009	321-5030-00
A56R3087	321-5030-00			RES, FXD, FILM: 10.0K, 1%, 0.125W	80009	321-5030-00
A56R4082	321-5030-00			RES, FXD, FILM: 10.0K, 1%, 0.125W	80009	321-5030-00
A56R4083	321-5030-00			RES, FXD, FILM: 10.0K, 1%, 0.125W	80009	321-5030-00
A56R4084	321-5030-00			RES, FXD, FILM: 10.0K, 1%, 0.125W	80009	321-5030-00
A56R4085	321-5030-00			RES, FXD, FILM: 10.0K, 1%, 0.125W	80009	321-5030-00
A56R4086	321-5030-00			RES, FXD, FILM: 10.0K, 1%, 0.125W	80009	321-5030-00
A56R6014	321-5010-00			RES, FXD, FILM: 221 OHM, 1%, 0.125W	80009	321-5010-00
A56U1010	160-3693-00	B010100	B010181	MICROCKT, DGTL: NMOS, 32 X 8 EPROM, PRGM	80009	160-3693-00
A56U1010	160-3693-02	B010182	B010209	MICROCKT, DGTL: NMOS, 32 X 8 EPROM, PRGM	80009	160-3693-02
A56U1010	160-3693-03	B010210	B010215	MICROCKT, DGTL: NMOS, 32 X 8 EPROM, PRGM	80009	160-3693-03
A56U1010	160-3693-04	B010216	B010216	MICROCKT, DGTL: NMOS, 32 X 8 EPROM, PRGM	80009	160-3693-04
A56U1010	160-3693-05	B010217	B020700	MICROCKT, DGTL: NMOS, 32 X 8 EPROM, PRGM	80009	160-3693-05
A56U1010	160-8317-00	B020701		MICROCKT, DGTL: NMOS, 32 X 8 EPROM, PRGM; ; D2725 6-3, DIP28	80009	160-8317-00
A56U1010	160-4489-00	B010100	B010502	MICROCKT, DGTL: NMOS, 32 X 8 EPROM, PRGM	80009	160-4489-00
A56U1010	160-4489-01	B010503		MICROCKT, DGTL: NMOS, 32 X 8 EPROM, PRGM (OPTION 45 ONLY)	80009	160-4489-01
A56U1020	160-3694-00	B010100	B010181	MICROCKT, DGTL: NMOS, 32 X 8 EPROM, PRGM	80009	160-3694-00
A56U1020	160-3694-02	B010182	B010209	MICROCKT, DGTL: NMOS, 32 X 8 EPROM, PRGM	80009	160-3694-02
A56U1020	160-3694-03	B010210	B010215	MICROCKT, DGTL: NMOS, 32 X 8 EPROM, PRGM	80009	160-3694-03
A56U1020	160-3694-04	B010216	B010216	MICROCKT, DGTL: NMOS, 32 X 8 EPROM, PRGM	80009	160-3694-04
A56U1020	160-3694-05	B010217	B020700	MICROCKT, DGTL: NMOS, 32 X 8 EPROM, PRGM	80009	160-3694-05

Replaceable Electrical Parts
494A/494AP Service Vol.2

Component No.	Tektronix Part No.	Serial/Assembly No. Effective	Discont.	Name & Description	Mfr. Code	Mfr. Part No.
A56U1020	160-8318-00	B020701		MICROCKT,DGTL:NMOS,32 X 8 EPROM,PRGM;;D2725 6-3,DIP28	80009	160-8318-00
A56U1020	160-4490-00	B010100	B010502	MICROCKT,DGTL:NMOS,32 X 8 EPROM,PRGM	80009	160-4490-00
A56U1020	160-4490-01	B010503		MICROCKT,DGTL:NMOS,32 X 8 EPROM,PRGM (OPTION 45 ONLY)	80009	160-4490-01
A56U1025	160-3695-00	B010100	B010181	MICROCKT,DGTL:NMOS,32 X 8 EPROM,PRGM	80009	160-3695-00
A56U1025	160-3695-02	B010182	B010209	MICROCKT,DGTL:NMOS,32 X 8 EPROM,PRGM	80009	160-3695-02
A56U1025	160-3695-03	B010210	B010215	MICROCKT,DGTL:NMOS,32 X 8 EPROM,PRGM	80009	160-3695-03
A56U1025	160-3695-04	B010216	B010216	MICROCKT,DGTL:NMOS,32 X 8 EPROM,PRGM	80009	160-3695-04
A56U1025	160-3695-05	B010217	B020700	MICROCKT,DGTL:NMOS,32 X 8 EPROM,PRGM	80009	160-3695-05
A56U1025	160-8319-00	B020701		MICROCKT,DGTL:NMOS,32 X 8 EPROM,PRGM;;D2725 6-3,DIP28	80009	160-8319-00
A56U1025	160-4491-00	B010100	B010502	MICROCKT,DGTL:NMOS,32 X 8 EPROM,PRGM	80009	160-4491-00
A56U1025	160-4491-01	B010503		MICROCKT,DGTL:NMOS,32 X 8 EPROM,PRGM (OPTION 45 ONLY)	80009	160-4491-01
A56U1035	160-3696-00	B010100	B010181	MICROCKT,DGTL:NMOS,32 X 8 EPROM,PRGM	80009	160-3696-00
A56U1035	160-3696-02	B010182	B010209	MICROCKT,DGTL:NMOS,32 X 8 EPROM,PRGM	80009	160-3696-02
A56U1035	160-3696-03	B010210	B010215	MICROCKT,DGTL:NMOS,32 X 8 EPROM,PRGM	80009	160-3696-03
A56U1035	160-3696-04	B010216	B010216	MICROCKT,DGTL:NMOS,32 X 8 EPROM,PRGM	80009	160-3696-04
A56U1035	160-3696-05	B010217	B020700	MICROCKT,DGTL:NMOS,32 X 8 EPROM,PRGM	80009	160-3696-05
A56U1035	160-8320-00	B020701		MICROCKT,DGTL:NMOS,32 X 8 EPROM,PRGM;;D2725 6-3,DIP28	80009	160-8320-00
A56U1035	160-4492-00	B010100	B010502	MICROCKT,DGTL:NMOS,32 X 8 EPROM,PRGM	80009	160-4492-00
A56U1035	160-4492-01	B010503		MICROCKT,DGTL:NMOS,32 X 8 EPROM,PRGM (OPTION 45 ONLY)	80009	160-4492-01
A56U1040	156-5033-00			IC,DIGITAL:LSSTTL,DEMUX/DECODER;3-TO-8 DECOD ER;74LS138,S016.150,TUBE	80009	156-5033-00
A56U1055	156-5033-00			IC,DIGITAL:LSSTTL,DEMUX/DECODER;3-TO-8 DECOD ER;74LS138,S016.150,TUBE	80009	156-5033-00
A56U2040	156-5001-00			IC,DIGITAL:LSSTTL,GATES;QUAD 2-INPUT NAND;74 LS00,S014.150,TUBE	01295	SN74LS00D
A56U2044	156-5009-00			IC,DIGITAL:LSSTTL,FLIP FLOP;OCTAL D-TYPE, CL EAR;74LS273,S020.300,TUBE	80009	156-5009-00
A56U2045	156-5006-00			IC,DIGITAL:LSSTTL,BUFFER;INV OCTAL, LINE DRI VER, 3-STATE;74LS240,S020.300,TUBE	80009	156-5006-00
A56U2050	156-1444-01			IC,PROCESSOR:NMOS,CONTROLLER;GPIB ADAPTER;T MS9914A,DIP40.6	80009	156-1444-01
A56U3015	160-3697-00	B010100	B010181	MICROCKT,DGTL:NMOS,32 X 8 EPROM,PRGM	80009	160-3697-00
A56U3015	160-3697-02	B010182	B010209	MICROCKT,DGTL:NMOS,32 X 8 EPROM,PRGM	80009	160-3697-02
A56U3015	160-3697-03	B010210	B010215	MICROCKT,DGTL:NMOS,32 X 8 EPROM,PRGM	80009	160-3697-03
A56U3015	160-3697-04	B010216	B010216	MICROCKT,DGTL:NMOS,32 X 8 EPROM,PRGM	80009	160-3697-04
A56U3015	160-3697-05	B010217	B020700	MICROCKT,DGTL:NMOS,32 X 8 EPROM,PRGM	80009	160-3697-05
A56U3015	160-8321-00	B020701		MICROCKT,DGTL:NMOS,32 X 8 EPROM,PRGM;;D2725 6-3,DIP28	80009	160-8321-00
A56U3015	160-4493-00	B010100	B010502	MICROCKT,DGTL:NMOS,32 X 8 EPROM,PRGM	80009	160-4493-00
A56U3015	160-4493-01	B010503		MICROCKT,DGTL:NMOS,32 X 8 EPROM,PRGM (OPTION 45 ONLY)	80009	160-4493-01
A56U3020	160-3698-00	B010100	B010181	MICROCKT,DGTL:NMOS,32 X 8 EPROM,PRGM	80009	160-3698-00
A56U3020	160-3698-02	B010182	B010209	MICROCKT,DGTL:NMOS,32 X 8 EPROM,PRGM	80009	160-3698-02
A56U3020	160-3698-03	B010210	B010215	MICROCKT,DGTL:NMOS,32 X 8 EPROM,PRGM	80009	160-3698-03
A56U3020	160-3698-04	B010216	B010216	MICROCKT,DGTL:NMOS,32 X 8 EPROM,PRGM	80009	160-3698-04
A56U3020	160-8322-00	B020701		MICROCKT,DGTL:NMOS,32 X 8 EPROM,PRGM;;D2725 6-3,DIP28	80009	160-8322-00
A56U3020	160-4494-00	B010100	B010502	MICROCKT,DGTL:NMOS,32 X 8 EPROM,PRGM	80009	160-4494-00
A56U3020	160-4494-01	B010503		MICROCKT,DGTL:NMOS,32 X 8 EPROM,PRGM (OPTION 45 ONLY)	80009	160-4494-01
A56U3030	160-3699-00	B010100	B010181	MICROCKT,DGTL:NMOS,32 X 8 EPROM,PRGM	80009	160-3699-00
A56U3030	160-3699-02	B010182	B010209	MICROCKT,DGTL:NMOS,32 X 8 EPROM,PRGM	80009	160-3699-02
A56U3030	160-3699-03	B010210	B010215	MICROCKT,DGTL:NMOS,32 X 8 EPROM,PRGM	80009	160-3699-03
A56U3030	160-3699-04	B010216	B010216	MICROCKT,DGTL:NMOS,32 X 8 EPROM,PRGM	80009	160-3699-04
A56U3030	160-3699-05	B010217	B020700	MICROCKT,DGTL:NMOS,32 X 8 EPROM,PRGM	80009	160-3699-05

Replaceable Electrical Parts
494A/494AP Service Vol.2

Component No.	Tektronix Part No.	Serial/Assembly No. Effective	Discont	Name & Description	Mfr. Code	Mfr. Part No.
A56U3030	160-8323-00	B020701		MICROCKT,DGTL:NMOS,32 X 8 EPROM,PRGM;;D2725 6-3,DIP28	80009	160-8323-00
A56U3030	160-4495-00	B010100	B010502	MICROCKT,DGTL:NMOS,32 X 8 EPROM,PRGM	80009	160-4495-00
A56U3030	160-4495-01	B010503		MICROCKT,DGTL:NMOS,32 X 8 EPROM,PRGM (OPTION 45 ONLY)	80009	160-4495-01
A56U3040	156-5001-00			IC,DIGITAL:LSTTL,GATES;QUAD 2-INPUT NAND;74 LS00,S014.150,TUBE	01295	SN74LS00D
A56U3045	156-5036-00			IC,DIGITAL:LSTTL,GATES;QUAD 2-INPUT XOR;74LS86,S014.150,TUBE	80009	156-5036-00
A56U4040	156-5001-00			IC,DIGITAL:LSTTL,GATES;QUAD 2-INPUT NAND;74 LS00,S014.150,TUBE	01295	SN74LS00D
A56W1044	321-5051-00			RES,FXD,FILM:0 OHM,1%,0.125W	80009	321-5051-00
A58	670-8882-00	B010100	B020771	CIRCUIT BD ASSY:PROCESSOR	80009	670-8882-00
A58	670-8882-01	B020772		CKT BD SUBASSY:PROCESSOR;;388-0333-XX WIRED	80009	670-8882-01
A58C1015	283-5004-00			CAP,FXD,CER DI:0.1UF,10%,25V	80009	283-5004-00
A58C1016	283-5004-00			CAP,FXD,CER DI:0.1UF,10%,25V	80009	283-5004-00
A58C1017	283-5004-00			CAP,FXD,CER DI:0.1UF,10%,25V	80009	283-5004-00
A58C1025	283-5004-00			CAP,FXD,CER DI:0.1UF,10%,25V	80009	283-5004-00
A58C1026	283-5004-00			CAP,FXD,CER DI:0.1UF,10%,25V	80009	283-5004-00
A58C1027	283-5004-00			CAP,FXD,CER DI:0.1UF,10%,25V	80009	283-5004-00
A58C1028	283-5004-00			CAP,FXD,CER DI:0.1UF,10%,25V	80009	283-5004-00
A58C1031	283-5004-00			CAP,FXD,CER DI:0.1UF,10%,25V	80009	283-5004-00
A58C1032	283-5004-00			CAP,FXD,CER DI:0.1UF,10%,25V	80009	283-5004-00
A58C1033	283-5001-00			CAP,FXD,CER DI:100PF,5%,50V	80009	283-5001-00
A58C1034	283-5004-00			CAP,FXD,CER DI:0.1UF,10%,25V	80009	283-5004-00
A58C1035	283-5001-00			CAP,FXD,CER DI:100PF,5%,50V	80009	283-5001-00
A58C1036	283-5004-00			CAP,FXD,CER DI:0.1UF,10%,25V	80009	283-5004-00
A58C2015	283-5004-00			CAP,FXD,CER DI:0.1UF,10%,25V	80009	283-5004-00
A58C2030	290-5003-00	B010100	B020771	CAP,FXD,ELCTLT:47UF,20%,10V	80009	290-5003-00
A58C2030	290-5003-01	B020772		CAP,FXD,TANT:DRY:47UF,20%,10V,TANT OXIDE,0.287 X 0.170;7343,SMD,12 MM T&R,16MM H	80009	290-5003-01
A58C2031	283-5004-00			CAP,FXD,CER DI:0.1UF,10%,25V	80009	283-5004-00
A58C2032	283-5004-00			CAP,FXD,CER DI:0.1UF,10%,25V	80009	283-5004-00
A58C2033	283-5001-00			CAP,FXD,CER DI:100PF,5%,50V	80009	283-5001-00
A58C2034	283-5002-00			CAP,FXD,CER DI:1000PF,10%,50V	80009	283-5002-00
A58C2035	283-5001-00			CAP,FXD,CER DI:100PF,5%,50V	80009	283-5001-00
A58C2036	283-5004-00			CAP,FXD,CER DI:0.1UF,10%,25V	80009	283-5004-00
A58C3015	283-5004-00			CAP,FXD,CER DI:0.1UF,10%,25V	80009	283-5004-00
A58C3020	283-5004-00			CAP,FXD,CER DI:0.1UF,10%,25V	80009	283-5004-00
A58C3025	283-5004-00			CAP,FXD,CER DI:0.1UF,10%,25V	80009	283-5004-00
A58C3030	283-5004-00			CAP,FXD,CER DI:0.1UF,10%,25V	80009	283-5004-00
A58C3034	283-5004-00			CAP,FXD,CER DI:0.1UF,10%,25V	80009	283-5004-00
A58C3035	290-5001-00	B010100	B020771	CAP,FXD,ELCTLT:10UF,20%,16V	TK0900	ALCHIP-S16V10UF
A58C3035	290-5039-00	B020772		CAP,FXD,ALUM:10UF,20%,50V,6.3MM,SMD,16MM TA PE & REEL.	80009	290-5039-00
A58C3036	290-5003-00	B010100	B020771	CAP,FXD,ELCTLT:47UF,20%,10V	80009	290-5003-00
A58C3036	290-5003-01	B020772		CAP,FXD,TANT:DRY:47UF,20%,10V,TANT OXIDE,0.287 X 0.170;7343,SMD,12 MM T&R,16MM H	80009	290-5003-01
A58CR1030	152-5000-00			SEMICON DVC,DI:SW,SI,70V,COM CATHODE	80009	152-5000-00
A58CR2020	152-5000-00			SEMICON DVC,DI:SW,SI,70V,COM CATHODE	80009	152-5000-00
A58CR2025	152-5000-00			SEMICON DVC,DI:SW,SI,70V,COM CATHODE	80009	152-5000-00
A58L1035	108-5002-00			COIL,RF:	TK0510	ELJ-FB150KE
A58L3035	108-0836-00			COIL,RF:FIXED,14UH	80009	108-0836-00
A58Q1030	151-5001-00			TRANSISTOR,SIG:BIPOLAR,NPN;40V,200MA,300MHZ ,AMPLIFIER;MMBT3904L,TO-236/SOT-23,8MM T&R	80009	151-5001-00
A58Q2030	151-5001-00			TRANSISTOR,SIG:BIPOLAR,NPN;40V,200MA,300MHZ ,AMPLIFIER;MMBT3904L,TO-236/SOT-23,8MM T&R	80009	151-5001-00

Replaceable Electrical Parts
494A/494AP Service Vol.2

Component No.	Tektronix Part No.	Serial/Assembly No. Effective	Discont	Name & Description	Mfr. Code	Mfr. Part No.
A58Q2035	151-5001-00			TRANSISTOR, SIG: BIPOLAR, NPN; 40V, 200MA, 300MHZ ,AMPLIFIER;MMBT3904L, TO-236/SOT-23, 8MM T&R	80009	151-5001-00
A58R1010	321-5027-00			RES, FXD, FILM: 5.62K, 1%, 0.125W	80009	321-5027-00
A58R1021	321-5030-00			RES, FXD, FILM: 10.0K, 1%, 0.125W	80009	321-5030-00
A58R1022	321-5030-00			RES, FXD, FILM: 10.0K, 1%, 0.125W	80009	321-5030-00
A58R1023	321-5030-00			RES, FXD, FILM: 10.0K, 1%, 0.125W	80009	321-5030-00
A58R1024	321-5030-00			RES, FXD, FILM: 10.0K, 1%, 0.125W	80009	321-5030-00
A58R1025	321-5027-00			RES, FXD, FILM: 5.62K, 1%, 0.125W	80009	321-5027-00
A58R1026	321-5027-00			RES, FXD, FILM: 5.62K, 1%, 0.125W	80009	321-5027-00
A58R1030	321-5030-00			RES, FXD, FILM: 10.0K, 1%, 0.125W	80009	321-5030-00
A58R1031	321-5030-00			RES, FXD, FILM: 10.0K, 1%, 0.125W	80009	321-5030-00
A58R1032	321-5035-00			RES, FXD, FILM: 27.4K, 1%, 0.125W	80009	321-5035-00
A58R1033	321-5030-00			RES, FXD, FILM: 10.0K, 1%, 0.125W	80009	321-5030-00
A58R1034	321-5018-00			RES, FXD, FILM: 1.00K, 1%, 0.125W	80009	321-5018-00
A58R1035	321-5021-00			RES, FXD, FILM: 1.82K, 1%, 0.125W	80009	321-5021-00
A58R1036	321-5035-00			RES, FXD, FILM: 27.4K, 1%, 0.125W	80009	321-5035-00
A58R1037	321-5035-00			RES, FXD, FILM: 27.4K, 1%, 0.125W	80009	321-5035-00
A58R1038	321-5030-00			RES, FXD, FILM: 10.0K, 1%, 0.125W	80009	321-5030-00
A58R2020	321-5030-00			RES, FXD, FILM: 10.0K, 1%, 0.125W	80009	321-5030-00
A58R2021	321-5030-00			RES, FXD, FILM: 10.0K, 1%, 0.125W	80009	321-5030-00
A58R2022	321-5030-00			RES, FXD, FILM: 10.0K, 1%, 0.125W	80009	321-5030-00
A58R2023	321-5030-00			RES, FXD, FILM: 10.0K, 1%, 0.125W	80009	321-5030-00
A58R2024	321-5030-00			RES, FXD, FILM: 10.0K, 1%, 0.125W	80009	321-5030-00
A58R2025	321-5030-00			RES, FXD, FILM: 10.0K, 1%, 0.125W	80009	321-5030-00
A58R2030	321-5030-00			RES, FXD, FILM: 10.0K, 1%, 0.125W	80009	321-5030-00
A58R2031	321-5030-00			RES, FXD, FILM: 10.0K, 1%, 0.125W	80009	321-5030-00
A58R2032	321-5018-00			RES, FXD, FILM: 1.00K, 1%, 0.125W	80009	321-5018-00
A58R2033	321-5030-00			RES, FXD, FILM: 10.0K, 1%, 0.125W	80009	321-5030-00
A58R2034	321-5021-00			RES, FXD, FILM: 1.82K, 1%, 0.125W	80009	321-5021-00
A58R2035	321-5030-00			RES, FXD, FILM: 10.0K, 1%, 0.125W	80009	321-5030-00
A58R2036	321-5018-00			RES, FXD, FILM: 1.00K, 1%, 0.125W	80009	321-5018-00
A58R2037	321-5035-00			RES, FXD, FILM: 27.4K, 1%, 0.125W	80009	321-5035-00
A58R2038	321-5018-00			RES, FXD, FILM: 1.00K, 1%, 0.125W	80009	321-5018-00
A58R2039	321-5018-00			RES, FXD, FILM: 1.00K, 1%, 0.125W	80009	321-5018-00
A58R2045	321-5027-00			RES, FXD, FILM: 5.62K, 1%, 0.125W	80009	321-5027-00
A58R3010	321-5030-00			RES, FXD, FILM: 10.0K, 1%, 0.125W	80009	321-5030-00
A58R3011	321-5030-00			RES, FXD, FILM: 10.0K, 1%, 0.125W	80009	321-5030-00
A58R3012	321-5030-00			RES, FXD, FILM: 10.0K, 1%, 0.125W	80009	321-5030-00
A58R3013	321-5030-00			RES, FXD, FILM: 10.0K, 1%, 0.125W	80009	321-5030-00
A58R3014	321-5030-00			RES, FXD, FILM: 10.0K, 1%, 0.125W	80009	321-5030-00
A58R3015	321-5030-00			RES, FXD, FILM: 10.0K, 1%, 0.125W	80009	321-5030-00
A58R3016	321-5030-00			RES, FXD, FILM: 10.0K, 1%, 0.125W	80009	321-5030-00
A58R3017	321-5030-00			RES, FXD, FILM: 10.0K, 1%, 0.125W	80009	321-5030-00
A58R3030	321-5021-00			RES, FXD, FILM: 1.82K, 1%, 0.125W	80009	321-5021-00
A58R3031	321-5021-00			RES, FXD, FILM: 1.82K, 1%, 0.125W	80009	321-5021-00
A58R3032	321-5018-00			RES, FXD, FILM: 1.00K, 1%, 0.125W	80009	321-5018-00
A58R3033	321-5021-00			RES, FXD, FILM: 1.82K, 1%, 0.125W	80009	321-5021-00
A58R3034	321-5030-00			RES, FXD, FILM: 10.0K, 1%, 0.125W	80009	321-5030-00
A58R3035	321-5021-00			RES, FXD, FILM: 1.82K, 1%, 0.125W	80009	321-5021-00
A58R3036	321-5006-00			RES, FXD, FILM: 100 OHM, 1%, 0.125W	80009	321-5006-00
A58R3037	321-5021-00			RES, FXD, FILM: 1.82K, 1%, 0.125W	80009	321-5021-00
A58R3044	321-5030-00			RES, FXD, FILM: 10.0K, 1%, 0.125W	80009	321-5030-00
A58U1010	156-0427-03	B010100	B010171	MICROCKT, DGTL: NMOS, PERIPHERAL INTFC ADPTR	04713	MC6821L
A58U1010	156-0427-04	B010172		IC, PROCESSOR: CMOS, PERIPHERAL; PERIPHERAL INT ERFACE ADAPTER; 6821, DIP40. 6, TUBE	04713	MC6821LD
A58U1015	156-5016-00			IC, DIGITAL: LSTTL, BUS TRANSCEIVER; OCTAL, NON INV, 3-STATE; 74LS245, SO20.300, TUBE	80009	156-5016-00

Replaceable Electrical Parts
494A/494AP Service Vol.2

Component No.	Tektronix Part No.	Serial/Assembly No. Effective	Discont	Name & Description	Mfr. Code	Mfr. Part No.
A58U1020	156-1458-00			IC,PROCESSOR:NMOS,PERIPHERAL;DMA CONTROLLER;6844,DIP40.6	04713	MC6844 (P OR L)
A58U1024	156-5034-00			IC,DIGITAL:LSTTL,BUFFER;NONINV, OCTAL, LINE DRIVER, 3-STATE;74LS244,S020.300,TUBE	80009	156-5034-00
A58U1025	156-1342-01	B010100	B010204	MICROCKT,DGTL:NMOS,MPU,8-BIT W/CLK	80009	156-1342-01
A58U1025	156-1342-00	B010205		IC,PROCESSOR:NMOS,8 BIT W/CLOCK & RAM6802,4 0 DIP,CER PKG	80009	156-1342-00
A58U1030	156-5048-00			IC,DIGITAL:LSTTL,GATE;QUAD 2-INPUT AND, OC; 74LS09,S014.150	80009	156-5048-00
A58U1035	156-5010-00			IC,DIGITAL:LSTTL,GATE;HEX INV;74LS04,S014.1 50,TUBE	18324	N74LS04D
A58U2015	156-1426-00			IC,PROCESSOR:NMOS,PERIPHERAL;PROGRAMMABLE TIMER MODULE;68B40,DIP28.3	04713	MC68B40 (L OR P)
A58U2025	156-5016-00			IC,DIGITAL:LSTTL,BUS TRANSCEIVER;OCTAL, NON INV, 3-STATE;74LS245,S020.300,TUBE	80009	156-5016-00
A58U2030	156-5034-00			IC,DIGITAL:LSTTL,BUFFER;NONINV, OCTAL, LINE DRIVER, 3-STATE;74LS244,S020.300,TUBE	80009	156-5034-00
A58U2035	156-5024-00			IC,DIGITAL:LSTTL,GATES;HEX INV, OC;74LS05,S 014.150,TUBE	01295	SN74LS05D
A58U2036	156-5012-00			IC,DIGITAL:LSTTL,GATES;DUAL 4-INPUT NAND;74 LS20,S014.150,TUBE	01295	SN74LS20D
A58U3010	156-5016-00			IC,DIGITAL:LSTTL,BUS TRANSCEIVER;OCTAL, NON INV, 3-STATE;74LS245,S020.300,TUBE	80009	156-5016-00
A58U3015	156-5034-00			IC,DIGITAL:LSTTL,BUFFER;NONINV, OCTAL, LINE DRIVER, 3-STATE;74LS244,S020.300,TUBE	80009	156-5034-00
A58U3020	156-5034-00			IC,DIGITAL:LSTTL,BUFFER;NONINV, OCTAL, LINE DRIVER, 3-STATE;74LS244,S020.300,TUBE	80009	156-5034-00
A58U3025	156-5034-00			IC,DIGITAL:LSTTL,BUFFER;NONINV, OCTAL, LINE DRIVER, 3-STATE;74LS244,S020.300,TUBE	80009	156-5034-00
A58U3030	156-5034-00			IC,DIGITAL:LSTTL,BUFFER;NONINV, OCTAL, LINE DRIVER, 3-STATE;74LS244,S020.300,TUBE	80009	156-5034-00
A58U3035	156-5033-00			IC,DIGITAL:LSTTL,DEMUX/DECODER;3-TO-8 DECOD ER;74LS138,S016.150,TUBE	80009	156-5033-00
A58U3036	156-5014-00			IC,DIGITAL:LSTTL,GATES;QUAD TWO-INPUT OR;74 LS32,S014.150,TUBE	01295	SN74LS32D
A58W2035	321-5051-00			RES,FXD,FILM:0 OHM,1%,0.125W	80009	321-5051-00
A58Y1030	158-0257-00			XTAL UNIT,QTZ:3.4133MHZ,0.01%,ANTIRESONANT	80009	158-0257-00
A60	670-9100-02			CIRCUIT BD ASSY:DIGITAL STORAGE INTERFACE	80009	670-9100-02
A60C1031	283-0346-00			CAP,FXD,CER DI:0.47UF,+80-20%,100V	20932	5034ES100RD474Z
A60C2061	283-0065-00			CAP,FXD,CER DI:0.001UF,5%,50V	80009	283-0065-00
A60C5061	283-0065-00			CAP,FXD,CER DI:0.001UF,5%,50V	80009	283-0065-00
A60C6011	283-0111-00			CAP,FXD,CER DI:0.1UF,20%,50V	80009	283-0111-00
A60C6041	290-0527-00			CAP,FXD,ELCTLT:15UF,20%,20V	05397	T368B156M020AS
A60C6042	290-0527-00			CAP,FXD,ELCTLT:15UF,20%,20V	05397	T368B156M020AS
A60C6043	290-0527-00			CAP,FXD,ELCTLT:15UF,20%,20V	05397	T368B156M020AS
A60C6051	283-0346-00			CAP,FXD,CER DI:0.47UF,+80-20%,100V	20932	5034ES100RD474Z
A60L6041	108-0598-00			COIL,RF:FIXED,200UH	80009	108-0598-00
A60L6042	108-0598-00			COIL,RF:FIXED,200UH	80009	108-0598-00
A60L6043	108-0598-00			COIL,RF:FIXED,200UH	80009	108-0598-00
A60R1011	315-0153-00			RES,FXD,FILM:15K OHM,5%,0.25W	80009	315-0153-00
A60R1032	321-0199-00			RES,FXD,FILM:1.15K OHM,1%,0.125W,TC=TO	07716	CEAD11500F
A60R1033	321-0277-00			RES,FXD,FILM:7.50K OHM,1%,0.125W,TC=TO	2M627	CRA18CRB14F7.5K
A60R1034	321-0188-00			RES,FXD,FILM:887 OHM,1%,0.125W,TC=TO	07716	CEAD887R0F
A60R1040	311-1915-00			RES,VAR,NONWV:TRMR,20K OHM,10%,0.5 W	32997	3386C-1-203
A60R1050	311-1921-00			RES,VAR,NONWV:TRMR,250 OHM,10%,0.5 W	32997	3386C-1-251
A60R1053	321-0188-00			RES,FXD,FILM:887 OHM,1%,0.125W,TC=TO	07716	CEAD887R0F
A60R1055	311-1915-00			RES,VAR,NONWV:TRMR,20K OHM,10%,0.5 W	32997	3386C-1-203
A60R1060	311-1921-00			RES,VAR,NONWV:TRMR,250 OHM,10%,0.5 W	32997	3386C-1-251

Replaceable Electrical Parts
494A/494AP Service Vol.2

Component No.	Tektronix		Serial/Assembly No. Effective Dscnt	Name & Description	Mfr.	
	Part No.				Code	Mfr. Part No.
A60R3011	315-0152-00			RES,FXD,FILM:1.5K OHM,5%,0.25W	80009	315-0152-00
A60R3061	315-0102-00			RES,FXD,FILM:1K OHM,5%,0.25W	80009	315-0102-00
A60R3062	321-0412-00			RES,FXD,FILM:191K OHM,1%,0.125W,TC=TO	07716	CEAD19102F
A60R3063	321-0232-00			RES,FXD,FILM:2.55K OHM,1%,0.125W,TC=TO	80009	321-0232-00
A60R4040	315-0100-00			RES,FXD,FILM:10 OHM,5%,0.25W	19701	5043CX10RR00J
A60R4061	315-0102-00			RES,FXD,FILM:1K OHM,5%,0.25W	80009	315-0102-00
A60R5041	315-0221-00			RES,FXD,FILM:220 OHM,5%,0.25W	80009	315-0221-00
A60R5042	321-0402-00			RES,FXD,FILM:150K OHM,1%,0.125W,TC=TO	19701	5033ED150K0F
A60R5061	321-0412-00			RES,FXD,FILM:191K OHM,1%,0.125W,TC=TO	07716	CEAD19102F
A60R5062	321-0277-00			RES,FXD,FILM:7.50K OHM,1%,0.125W,TC=TO	2M627	CRA18CRB14F7.5K
A60R5063	321-0232-00			RES,FXD,FILM:2.55K OHM,1%,0.125W,TC=TO	80009	321-0232-00
A60R6011	307-0446-00			RES NTWK,FXD,FI:10K OHM,20%,(9)RES	80009	307-0446-00
A60R6041	307-0446-00			RES NTWK,FXD,FI:10K OHM,20%,(9)RES	80009	307-0446-00
A60R6051	321-0277-00			RES,FXD,FILM:7.50K OHM,1%,0.125W,TC=TO	2M627	CRA18CRB14F7.5K
A60R6052	315-0102-00			RES,FXD,FILM:1K OHM,5%,0.25W	80009	315-0102-00
A60R6053	315-0103-00			RES,FXD,FILM:10K OHM,5%,0.25W	80009	315-0103-00
A60U1010	156-0385-00			IC,DIGITAL:LSTTL,GATES;HEX INV;74LS04,DIP14 .3,TUBE	80009	156-0385-00
A60U1020	156-0391-00			IC,DIGITAL:LSTTL,FLIP FLOP;HEX D W/CLR;74LS 174,DIP16.3,TUBE	80009	156-0391-00
A60U2010	156-0480-00			IC,DIGITAL:LSTTL,GATES;QUAD 2-INPUT AND;74L S08,DIP14.3,TUBE	80009	156-0480-00
A60U2020	156-0927-02	B010100	B010156	MICROCKT,LINEAR:DIGITAL/ANALOG CONVERTER	80009	156-0927-02
A60U2020	156-0927-00	B010157		MICROCKT,LINEAR:DGTL TO ANLG CONV	18324	MC3410(CF OR F)
A60U2030	156-0391-00			IC,DIGITAL:LSTTL,FLIP FLOP;HEX D W/CLR;74LS 174,DIP16.3,TUBE	80009	156-0391-00
A60U2040	156-0452-00			IC,DIGITAL:LSTTL,GATES;4-WIDE 2-INPUT AND-O R-INV;74LS54,DIP14.3,TUBE	80009	156-0452-00
A60U2050	156-0388-00			IC,DIGITAL:LSTTL,FLIP FLOP;DUAL D W/SET & C LR;74LS74,DIP14.3,TUBE	80009	156-0388-00
A60U3010	156-0382-00			IC,DIGITAL:LSTTL,GATE;QUAD 2-INPUT NAND;74L S00,DIP14.3,TUBE	80009	156-0382-00
A60U3020	156-2565-00			MICROCKT,DGTL:MOS,CUSTOM,INTEGRATED WAVEFO RM PROCESSOR	80009	156-2565-00
A60U3040	156-0391-00			IC,DIGITAL:LSTTL,FLIP FLOP;HEX D W/CLR;74LS 174,DIP16.3,TUBE	80009	156-0391-00
A60U3050	156-1226-00			IC,LINEAR:BIPOLAR,COMPARATOR;DUAL,OPEN COLL ECTOR,80NS;LM319N,DIP14.3	18324	LM319F
A60U4010	156-1228-00			IC,MEMORY:NMOS,SRAM;4K X 1,70NS;,DIP18.3	34335	AM2147-70DC
A60U4040	156-0927-02	B010100	B010156	MICROCKT,LINEAR:DIGITAL/ANALOG CONVERTER	80009	156-0927-02
A60U4040	156-0927-00	B010157		MICROCKT,LINEAR:DGTL TO ANLG CONV	18324	MC3410(CF OR F)
A60U4060	156-1126-00			IC,LINEAR:BIPOLAR,COMPARATOR;OPEN COLLECTOR ,200NS;LM311N,DIP08.3	80009	156-1126-00
A60U5010	156-1228-00			IC,MEMORY:NMOS,SRAM;4K X 1,70NS;,DIP18.3	34335	AM2147-70DC
A60U5020	156-2566-01			MICROCKT,DGTL:CMOS,ASIC,STD CELL,HORIZ DGTL STORAGE PINS 16 & 18 NOT CONNECTED	80009	156-2566-01
A60U5040	156-0852-00			IC,DIGITAL:LSTTL,GATES;NONINV, HEX BUS DRIV ER, 3-STATE;74LS367,DIP16.3,TUBE	80009	156-0852-00
A60U6010	156-0391-00			IC,DIGITAL:LSTTL,FLIP FLOP;HEX D W/CLR;74LS 174,DIP16.3,TUBE	80009	156-0391-00
A60U6020	156-0956-00			IC,DIGITAL:LSTTL,BUFFER/DRIVER;OCTAL NONINV , 3-STATE;74LS244,DIP20.3,TUBE	80009	156-0956-00
A60U6030	156-0469-00			IC,DIGITAL:LSTTL,DEMUX/DECODER;3-TO-8 DECOD ER;74LS138,DIP16.3,TUBE	80009	156-0469-00
A60U6060	156-1272-03			IC,LINEAR:BIPOLAR,OP-AMP;DUAL,HIGH OUTPUT D RIVE,MAX NOISE SPECS;NE5532AN,DIP08.3	80009	156-1272-03
A60W2011	131-0566-00			BUS,CONDUCTOR:DUMMY RES,0.094 OD X 0.225 L	80009	131-0566-00
A61	672-0163-01			CIRCUIT BD ASSY:VERTICAL DIGITAL STORAGE	80009	672-0163-01

Replaceable Electrical Parts
494A/494AP Service Vol.2

Component No.	Tektronix Part No.	Serial/Assembly No. Effective Dscnt	Name & Description	Mfr. Code	Mfr. Part No.
A61A1	670-9099-01		CIRCUIT BD ASSY:DIGITAL STORAGE	80009	670-9099-01
A61A1C1031	285-1062-00		CAP,FXD,PLASTIC:0.005UF,1%,200V	80009	285-1062-00
A61A1C1035	285-1062-00		CAP,FXD,PLASTIC:0.005UF,1%,200V	80009	285-1062-00
A61A1C1039	283-0221-00		CAP,FXD,CER DI:0.47UF,20%,50V	04222	SR305C474MAA
A61A1C1045	283-0197-00		CAP,FXD,CER DI:470PF,5%,50V	05397	C320C471J5G5CA
A61A1C2034	283-0204-00		CAP,FXD,CER DI:0.01UF,20%,50V	51406	RPE110Z5U103M50V
A61A1C2035	283-0204-00		CAP,FXD,CER DI:0.01UF,20%,50V	51406	RPE110Z5U103M50V
A61A1C2045	283-0197-00		CAP,FXD,CER DI:470PF,5%,50V	05397	C320C471J5G5CA
A61A1C3035	283-0346-00		CAP,FXD,CER DI:0.47UF,+80-20%,100V	20932	5034ES100RD474Z
A61A1C3037	290-0527-00		CAP,FXD,ELCTLT:15UF,20%,20V	05397	T368B156M020AS
A61A1C3040	290-0527-00		CAP,FXD,ELCTLT:15UF,20%,20V	05397	T368B156M020AS
A61A1C3045	290-0527-00		CAP,FXD,ELCTLT:15UF,20%,20V	05397	T368B156M020AS
A61A1C3046	290-0527-00		CAP,FXD,ELCTLT:15UF,20%,20V	05397	T368B156M020AS
A61A1C3047	283-0346-00		CAP,FXD,CER DI:0.47UF,+80-20%,100V	20932	5034ES100RD474Z
A61A1L4035	108-0537-00		COIL,RF:FIXED,200UH	80009	108-0537-00
A61A1L4036	108-0537-00		COIL,RF:FIXED,200UH	80009	108-0537-00
A61A1L4045	108-0537-00		COIL,RF:FIXED,200UH	80009	108-0537-00
A61A1L4046	108-0537-00		COIL,RF:FIXED,200UH	80009	108-0537-00
A61A1Q4045	151-0302-00		TRANSISTOR,SIG:BIPOLAR,NPN;40V,800MA,300MHZ	80009	151-0302-00
A61A1R1014	315-0102-00		,AMPLIFIER;2N2222A,TO-18		
A61A1R1015	307-0446-00		RES,FXD,FILM:1K OHM,5%,0.25W	80009	315-0102-00
A61A1R1033	311-1236-00		RES NTWK,FXD,FI:10K OHM,20%,(9)RES	80009	307-0446-00
A61A1R1034	311-1236-00		RES,VAR,NONWW:TRMR,250 OHM,0.5W	80009	311-1236-00
A61A1R1035	321-0188-00		RES,FXD,FILM:887 OHM,1%,0.125W,TC=TO	07716	CEAD887ROF
A61A1R1036	321-0218-00		RES,FXD,FILM:1.82K OHM,1%,0.125W,TC=TO	80009	321-0218-00
A61A1R1037	321-0360-00		RES,FXD,FILM:54.9K OHM,1%,0.125W,TC=TO	19701	5033ED54K90F
A61A1R1043	321-0395-00		RES,FXD,FILM:127K OHM,1%,0.125W,TC=TO	07716	CEAD12702F
A61A1R1044	315-0103-00		RES,FXD,FILM:10K OHM,5%,0.25W	80009	315-0103-00
A61A1R1045	311-1198-00		RES,VAR,NONWW:TRMR,20K OHM,0.5W	80009	311-1198-00
A61A1R1046	311-1198-00		RES,VAR,NONWW:TRMR,20K OHM,0.5W	80009	311-1198-00
A61A1R2035	315-0102-00		RES,FXD,FILM:1K OHM,5%,0.25W	80009	315-0102-00
A61A1R2036	315-0102-00		RES,FXD,FILM:1K OHM,5%,0.25W	80009	315-0102-00
A61A1R2037	321-0267-00		RES,FXD,FILM:5.90K OHM,1%,0.125W,TC=TO	80009	321-0267-00
A61A1R2038	321-0201-00		RES,FXD,FILM:1.21K OHM,1%,0.125W,TC=TO	80009	321-0201-00
A61A1R2044	321-0188-00		RES,FXD,FILM:887 OHM,1%,0.125W,TC=TO	07716	CEAD887ROF
A61A1R2045	315-0105-00		RES,FXD,FILM:1M OHM,5%,0.25W	80009	315-0105-00
A61A1R2046	321-0364-00		RES,FXD,FILM:60.4K OHM,1%,0.125W,TC=TO	80009	321-0364-00
A61A1R2047	321-0222-00		RES,FXD,FILM:2.00K OHM,1%,0.125W,TC=TO	80009	321-0222-00
A61A1R2048	321-0395-00		RES,FXD,FILM:127K OHM,1%,0.125W,TC=TO	07716	CEAD12702F
A61A1R3035	315-0103-00		RES,FXD,FILM:10K OHM,5%,0.25W	80009	315-0103-00
A61A1R4014	307-0446-00		RES NTWK,FXD,FI:10K OHM,20%,(9)RES	80009	307-0446-00
A61A1R4044	321-0402-00		RES,FXD,FILM:150K OHM,1%,0.125W,TC=TO	19701	5033ED150K0F
A61A1R4045	321-0327-00		RES,FXD,FILM:24.9K OHM,1%,0.125W,TC=TO	07716	CEAD24901F
A61A1R4046	321-0385-00		RES,FXD,FILM:100K OHM,1%,0.125W,TC=TO	80009	321-0385-00
A61A1S1015	260-1721-00		SWITCH,ROCKER:8,SPST,125MA,30VDC	81073	76SB08S
A61A1U1010	156-0388-00		IC,DIGITAL:LS TTL,FLIP FLOP:DUAL D W/SET & C	80009	156-0388-00
			LR;74LS74,DIP14.3,TUBE		
A61A1U1035	156-1255-00		IC,CONVERTER:BIPOLAR,D/A;8 BIT,85NS,CURRENT	80009	156-1255-00
			OUT,MULTIPLYING;DAC08HP,DIP16.3		
A61A1U1040	156-0742-02		IC,LINEAR:BIPOLAR,OP-AMP;DUPLICATE OF 156-0	80009	156-0742-02
			742-00,DO NOT USE;LM318N,DIP08.3		
A61A1U1045	156-0742-02		IC,LINEAR:BIPOLAR,OP-AMP;DUPLICATE OF 156-0	80009	156-0742-02
			742-00,DO NOT USE;LM318N,DIP08.3		
A61A1U2010	156-0382-00		IC,DIGITAL:LS TTL,GATE;QUAD 2-INPUT NAND;74L	80009	156-0382-00
			S00,DIP14.3,TUBE		
A61A1U2015	156-0383-00		IC,DIGITAL:LS TTL,GATES;QUAD 2-INPUT NOR;74L	80009	156-0383-00
			S02,DIP14.3,TUBE		

Replaceable Electrical Parts
494A/494AP Service Vol.2

Component No.	Tektronix Part No.	Serial/Assembly No.		Name & Description	Mfr. Code	Mfr. Part No.
		Effective	Discont			
A61A1U2020	156-0994-00			IC,DIGITAL:LSTTL,MUX/ENCODER;8-TO-1, T&F OU TPUTS;74LS151,DIP16.3,TUBE	80009	156-0994-00
A61A1U2025	156-0865-00			IC,DIGITAL:LSTTL,FLIP FLOP;OCTAL D-TYPE, CL EAR;74LS273,DIP20.3,TUBE	80009	156-0865-00
A61A1U2026	156-0392-00			IC,DIGITAL:LSTTL,FLIP FLOP;QUAD D W/CLR;74L S175,DIP16.3,TUBE	80009	156-0392-00
A61A1U2027	156-0388-00			IC,DIGITAL:LSTTL,FLIP FLOP;DUAL D W/SET & C LR;74LS74,DIP14.3,TUBE	80009	156-0388-00
A61A1U2028	156-0865-00			IC,DIGITAL:LSTTL,FLIP FLOP;OCTAL D-TYPE, CL EAR;74LS273,DIP20.3,TUBE	80009	156-0865-00
A61A1U2030	155-0157-00			MICROCKT,DGTL: DIGITAL STORAGE VERTICAL	80009	155-0157-00
A61A1U2034	156-0330-00			IC,DIGITAL:CMOS,BUFFER;HEX;4050B,DIP16.3,TU BE	80009	156-0330-00
A61A1U2035	156-1226-00			IC,LINEAR:BIPOLAR,COMPARATOR;DUAL,OPEN COLL ECTOR,80NS;LM319N,DIP14.3	18324	LM319F
A61A1U2040	156-1211-00			IC,MISC:BIFET,ANALOG SWITCH;QUAD;LF13333,DI P16.3	80009	156-1211-00
A61A1U2045	156-0742-02			IC,LINEAR:BIPOLAR,OP-AMP;DUPLICATE OF 156-0 742-00,DO NOT USE;LM318N,DIP08.3	80009	156-0742-02
A61A1U3010	156-0480-00			IC,DIGITAL:LSTTL,GATES;QUAD 2-INPUT AND;74L S08,DIP14.3,TUBE	80009	156-0480-00
A61A1U3015	156-0718-00			IC,DIGITAL:LSTTL,GATES;TRIPLE 3-INPUT NOR;7 4LS27,DIP14.3,TUBE	80009	156-0718-00
A61A1U3020	156-0388-00			IC,DIGITAL:LSTTL,FLIP FLOP;DUAL D W/SET & C LR;74LS74,DIP14.3,TUBE	80009	156-0388-00
A61A1U3024	156-0382-00			IC,DIGITAL:LSTTL,GATE;QUAD 2-INPUT NAND;74L S00,DIP14.3,TUBE	80009	156-0382-00
A61A1U3025	156-1255-00			IC,CONVERTER:BIPOLAR,D/A;8 BIT,85NS,CURRENT OUT,MULTIPLYING:DAC08HP,DIP16.3	80009	156-1255-00
A61A1U3030	156-0172-00			IC,DIGITAL:	80009	156-0172-00
A61A1U3040	156-0742-02			IC,LINEAR:BIPOLAR,OP-AMP;DUPLICATE OF 156-0 742-00,DO NOT USE;LM318N,DIP08.3	80009	156-0742-02
A61A1U3045	156-0067-00			IC,LINEAR:BIPOLAR,OP-AMP;;741C,DIP08.3	80009	156-0067-00
A61A1U4010	156-0385-00			IC,DIGITAL:LSTTL,GATES;HEX INV;74LS04,DIP14 .3,TUBE	80009	156-0385-00
A61A1U4015	156-0994-00			IC,DIGITAL:LSTTL,MUX/ENCODER;8-TO-1, T&F OU TPUTS;74LS151,DIP16.3,TUBE	80009	156-0994-00
A61A1U4020	156-0975-00			IC,DIGITAL:LSTTL,SHIFT REGISTER;8-BIT UNIVE RSAL;74LS299,DIP20.3,TUBE	80009	156-0975-00
A61A1U4025	156-0469-00			IC,DIGITAL:LSTTL,DEMUX/DECODER;3-TO-8 DECOD ER;74LS138,DIP16.3,TUBE	80009	156-0469-00
A61A1U4030	156-0385-00			IC,DIGITAL:LSTTL,GATES;HEX INV;74LS04,DIP14 .3,TUBE	80009	156-0385-00
A61A1U4040	156-0382-00			IC,DIGITAL:LSTTL,GATE;QUAD 2-INPUT NAND;74L S00,DIP14.3,TUBE	80009	156-0382-00
A62	672-0187-00			CIRCUIT BD ASSY:LOG AMP	80009	672-0187-00
A62A1	670-9091-00			CIRCUIT BD ASSY:LOG AMP	80009	670-9091-00
A62A1C1018	283-0191-00			CAP,FXD,CER DI:0.022UF,20%,50V	05397	C320C223M5U1CA
A62A1C1019	283-0191-00			CAP,FXD,CER DI:0.022UF,20%,50V	05397	C320C223M5U1CA
A62A1C1031	283-0191-00			CAP,FXD,CER DI:0.022UF,20%,50V	05397	C320C223M5U1CA
A62A1C1033	283-0191-00			CAP,FXD,CER DI:0.022UF,20%,50V	05397	C320C223M5U1CA
A62A1C1041	283-0191-00			CAP,FXD,CER DI:0.022UF,20%,50V	05397	C320C223M5U1CA
A62A1C1043	283-0191-00			CAP,FXD,CER DI:0.022UF,20%,50V	05397	C320C223M5U1CA
A62A1C1049	283-0191-00			CAP,FXD,CER DI:0.022UF,20%,50V	05397	C320C223M5U1CA
A62A1C1051	283-0111-00			CAP,FXD,CER DI:0.1UF,20%,50V	80009	283-0111-00
A62A1C1061	283-0191-00			CAP,FXD,CER DI:0.022UF,20%,50V	05397	C320C223M5U1CA
A62A1C1062	283-0191-00			CAP,FXD,CER DI:0.022UF,20%,50V	05397	C320C223M5U1CA
A62A1C1063	283-0191-00			CAP,FXD,CER DI:0.022UF,20%,50V	05397	C320C223M5U1CA

Replaceable Electrical Parts
494A/494AP Service Vol.2

Component No.	Tektronix Part No.	Serial/Assembly No. Effective Discnt	Name & Description	Mfr. Code	Mfr. Part No.
A62A1C1069	283-0111-00		CAP, FXD, CER DI: 0.1UF, 20%, 50V	80009	283-0111-00
A62A1C1071	283-0191-00		CAP, FXD, CER DI: 0.022UF, 20%, 50V	05397	C320C223MSU1CA
A62A1C1072	283-0191-00		CAP, FXD, CER DI: 0.022UF, 20%, 50V	05397	C320C223MSU1CA
A62A1C1073	283-0191-00		CAP, FXD, CER DI: 0.022UF, 20%, 50V	05397	C320C223MSU1CA
A62A1C1089	283-0191-00		CAP, FXD, CER DI: 0.022UF, 20%, 50V	05397	C320C223MSU1CA
A62A1C1099	283-0191-00		CAP, FXD, CER DI: 0.022UF, 20%, 50V	05397	C320C223MSU1CA
A62A1C1108	283-0191-00		CAP, FXD, CER DI: 0.022UF, 20%, 50V	05397	C320C223MSU1CA
A62A1C2031	283-0191-00		CAP, FXD, CER DI: 0.022UF, 20%, 50V	05397	C320C223MSU1CA
A62A1C2033	283-0191-00		CAP, FXD, CER DI: 0.022UF, 20%, 50V	05397	C320C223MSU1CA
A62A1C2043	283-0191-00		CAP, FXD, CER DI: 0.022UF, 20%, 50V	05397	C320C223MSU1CA
A62A1C2052	283-0111-00		CAP, FXD, CER DI: 0.1UF, 20%, 50V	80009	283-0111-00
A62A1C2054	283-0191-00		CAP, FXD, CER DI: 0.022UF, 20%, 50V	05397	C320C223MSU1CA
A62A1C2062	283-0111-00		CAP, FXD, CER DI: 0.1UF, 20%, 50V	80009	283-0111-00
A62A1C2085	283-0191-00		CAP, FXD, CER DI: 0.022UF, 20%, 50V	05397	C320C223MSU1CA
A62A1C2088	283-0191-00		CAP, FXD, CER DI: 0.022UF, 20%, 50V	05397	C320C223MSU1CA
A62A1C2090	283-0191-00		CAP, FXD, CER DI: 0.022UF, 20%, 50V	05397	C320C223MSU1CA
A62A1C2098	283-0191-00		CAP, FXD, CER DI: 0.022UF, 20%, 50V	05397	C320C223MSU1CA
A62A1C2105	283-0191-00		CAP, FXD, CER DI: 0.022UF, 20%, 50V	05397	C320C223MSU1CA
A62A1C3011	283-0111-00		CAP, FXD, CER DI: 0.1UF, 20%, 50V	80009	283-0111-00
A62A1C3025	283-0191-00		CAP, FXD, CER DI: 0.022UF, 20%, 50V	05397	C320C223MSU1CA
A62A1C3035	283-0191-00		CAP, FXD, CER DI: 0.022UF, 20%, 50V	05397	C320C223MSU1CA
A62A1C3041	283-0111-00		CAP, FXD, CER DI: 0.1UF, 20%, 50V	80009	283-0111-00
A62A1C3049	283-0111-00		CAP, FXD, CER DI: 0.1UF, 20%, 50V	80009	283-0111-00
A62A1C3069	283-0191-00		CAP, FXD, CER DI: 0.022UF, 20%, 50V	05397	C320C223MSU1CA
A62A1C3071	283-0111-00		CAP, FXD, CER DI: 0.1UF, 20%, 50V	80009	283-0111-00
A62A1C3082	283-0191-00		CAP, FXD, CER DI: 0.022UF, 20%, 50V	05397	C320C223MSU1CA
A62A1C3098	283-0191-00		CAP, FXD, CER DI: 0.022UF, 20%, 50V	05397	C320C223MSU1CA
A62A1C3099	283-0191-00		CAP, FXD, CER DI: 0.022UF, 20%, 50V	05397	C320C223MSU1CA
A62A1C3100	283-0191-00		CAP, FXD, CER DI: 0.022UF, 20%, 50V	05397	C320C223MSU1CA
A62A1C3102	283-0191-00		CAP, FXD, CER DI: 0.022UF, 20%, 50V	05397	C320C223MSU1CA
A62A1C3105	283-0191-00		CAP, FXD, CER DI: 0.022UF, 20%, 50V	05397	C320C223MSU1CA
A62A1C3111	283-0191-00		CAP, FXD, CER DI: 0.022UF, 20%, 50V	05397	C320C223MSU1CA
A62A1C4011	283-0191-00		CAP, FXD, CER DI: 0.022UF, 20%, 50V	05397	C320C223MSU1CA
A62A1C4016	283-0191-00		CAP, FXD, CER DI: 0.022UF, 20%, 50V	05397	C320C223MSU1CA
A62A1C4027	283-0201-00		CAP, FXD, CER DI: 27PF, 10%, 200V	04222	SR152C270KAA
A62A1C4029	283-0177-00		CAP, FXD, CER DI: 1UF, +80-20%, 25V	04222	SR303E105ZAA
A62A1C4039	283-0191-00		CAP, FXD, CER DI: 0.022UF, 20%, 50V	05397	C320C223MSU1CA
A62A1C4041	283-0191-00		CAP, FXD, CER DI: 0.022UF, 20%, 50V	05397	C320C223MSU1CA
A62A1C4044	283-0191-00		CAP, FXD, CER DI: 0.022UF, 20%, 50V	05397	C320C223MSU1CA
A62A1C4045	283-0177-00		CAP, FXD, CER DI: 1UF, +80-20%, 25V	04222	SR303E105ZAA
A62A1C4097	283-0181-00		CAP, FXD, CER DI: 1.8PF, +/-0.1%, 100V	80009	283-0181-00
A62A1C5014	283-0191-00		CAP, FXD, CER DI: 0.022UF, 20%, 50V	05397	C320C223MSU1CA
A62A1C5024	283-0111-00		CAP, FXD, CER DI: 0.1UF, 20%, 50V	80009	283-0111-00
A62A1C5029	283-0177-00		CAP, FXD, CER DI: 1UF, +80-20%, 25V	04222	SR303E105ZAA
A62A1C5035	283-0000-00		CAP, FXD, CER DI: 0.001UF, +100-0%, 500V	80009	283-0000-00
A62A1C5039	283-0000-00		CAP, FXD, CER DI: 0.001UF, +100-0%, 500V	80009	283-0000-00
A62A1C5082	283-0140-00		CAP, FXD, CER DI: 4.7PF, +/-0.25PF, 50V	80009	283-0140-00
A62A1C5085	283-0160-00		CAP, FXD, CER DI: 1.5PF, +/-0.1PF, 50V	80009	283-0160-00
A62A1C5103	283-0339-00		CAP, FXD, CER DI: 0.22UF, 10%, 50V	04222	SR305C224KAA
A62A1C6021	283-0648-00		CAP, FXD, MICA DI: 10PF, +/-0.5PF, 500V	80009	283-0648-00
A62A1C6023	283-0204-00		CAP, FXD, CER DI: 0.01UF, 20%, 50V	51406	RPE110Z5U103M50V
A62A1C6029	283-0156-00		CAP, FXD, CER DI: 1000PF, +80-20%, 200V	04222	SR152E102ZAA
A62A1C6033	290-0574-00		CAP, FXD, ELCTLT: 47UF, 10%, 20V	05397	T368C476K0202AS
A62A1C7011	283-0639-00		CAP, FXD, MICA DI: 56PF, 1%, 500V	80009	283-0639-00
A62A1C7014	283-0641-00		CAP, FXD, MICA DI: 180PF, 1%, 100V	80009	283-0641-00
A62A1C7021	283-0599-00		CAP, FXD, MICA DI: 98PF, 5%, 500V	80009	283-0599-00
A62A1C7024	283-0728-00		CAP, FXD, MICA DI: 120PF, 1%, 500V	80009	283-0728-00
A62A1C7032	290-0574-00		CAP, FXD, ELCTLT: 47UF, 10%, 20V	05397	T368C476K0202AS

Replaceable Electrical Parts
494A/494AP Service Vol.2

Component No.	Tektronix	Serial/Assembly No.		Name & Description	Mfr.	Mfr. Part No.
	Part No.	Effective	Dscont		Code	
A62A1C7033	290-0574-00			CAP, FXD, ELCLTLT: 47UF, 10%, 20V	05397	T368C476K0202AS
A62A1C7073	283-0203-00			CAP, FXD, CER DI: 0.47UF, 20%, 50V	80009	283-0203-00
A62A1C7082	290-0574-00			CAP, FXD, ELCLTLT: 47UF, 10%, 20V	05397	T368C476K0202AS
A62A1C7093	283-0111-00			CAP, FXD, CER DI: 0.1UF, 20%, 50V	80009	283-0111-00
A62A1C7107	283-0157-00			CAP, FXD, CER DI: 7PF, 5%, 50V	04222	SR155A7RODAA
A62A1C8104	283-0114-00			CAP, FXD, CER DI: 1500PF, 5%, 200V	80009	283-0114-00
A62A1CR1061	152-0322-00			DIODE, SIG: SCHKY, ;15V, 410MVF AT 1MA, 1.2PF; 5 082-2811, T&R	80009	152-0322-00
A62A1CR2014	152-0322-00			DIODE, SIG: SCHKY, ;15V, 410MVF AT 1MA, 1.2PF; 5 082-2811, T&R	80009	152-0322-00
A62A1CR2015	152-0322-00			DIODE, SIG: SCHKY, ;15V, 410MVF AT 1MA, 1.2PF; 5 082-2811, T&R	80009	152-0322-00
A62A1CR2031	152-0322-00			DIODE, SIG: SCHKY, ;15V, 410MVF AT 1MA, 1.2PF; 5 082-2811, T&R	80009	152-0322-00
A62A1CR2032	152-0322-00			DIODE, SIG: SCHKY, ;15V, 410MVF AT 1MA, 1.2PF; 5 082-2811, T&R	80009	152-0322-00
A62A1CR2044	152-0322-00			DIODE, SIG: SCHKY, ;15V, 410MVF AT 1MA, 1.2PF; 5 082-2811, T&R	80009	152-0322-00
A62A1CR2045	152-0322-00			DIODE, SIG: SCHKY, ;15V, 410MVF AT 1MA, 1.2PF; 5 082-2811, T&R	80009	152-0322-00
A62A1CR2062	152-0322-00			DIODE, SIG: SCHKY, ;15V, 410MVF AT 1MA, 1.2PF; 5 082-2811, T&R	80009	152-0322-00
A62A1CR2065	152-0322-00			DIODE, SIG: SCHKY, ;15V, 410MVF AT 1MA, 1.2PF; 5 082-2811, T&R	80009	152-0322-00
A62A1CR2066	152-0322-00			DIODE, SIG: SCHKY, ;15V, 410MVF AT 1MA, 1.2PF; 5 082-2811, T&R	80009	152-0322-00
A62A1CR2074	152-0322-00			DIODE, SIG: SCHKY, ;15V, 410MVF AT 1MA, 1.2PF; 5 082-2811, T&R	80009	152-0322-00
A62A1CR2075	152-0322-00			DIODE, SIG: SCHKY, ;15V, 410MVF AT 1MA, 1.2PF; 5 082-2811, T&R	80009	152-0322-00
A62A1CR2076	152-0322-00			DIODE, SIG: SCHKY, ;15V, 410MVF AT 1MA, 1.2PF; 5 082-2811, T&R	80009	152-0322-00
A62A1CR2077	152-0322-00			DIODE, SIG: SCHKY, ;15V, 410MVF AT 1MA, 1.2PF; 5 082-2811, T&R	80009	152-0322-00
A62A1CR2087	152-0322-00			DIODE, SIG: SCHKY, ;15V, 410MVF AT 1MA, 1.2PF; 5 082-2811, T&R	80009	152-0322-00
A62A1CR2088	152-0322-00			DIODE, SIG: SCHKY, ;15V, 410MVF AT 1MA, 1.2PF; 5 082-2811, T&R	80009	152-0322-00
A62A1CR2089	152-0322-00			DIODE, SIG: SCHKY, ;15V, 410MVF AT 1MA, 1.2PF; 5 082-2811, T&R	80009	152-0322-00
A62A1CR3089	152-0322-00			DIODE, SIG: SCHKY, ;15V, 410MVF AT 1MA, 1.2PF; 5 082-2811, T&R	80009	152-0322-00
A62A1CR4012	152-0322-00			DIODE, SIG: SCHKY, ;15V, 410MVF AT 1MA, 1.2PF; 5 082-2811, T&R	80009	152-0322-00
A62A1CR4015	152-0322-00			DIODE, SIG: SCHKY, ;15V, 410MVF AT 1MA, 1.2PF; 5 082-2811, T&R	80009	152-0322-00
A62A1CR4097	152-0322-00			DIODE, SIG: SCHKY, ;15V, 410MVF AT 1MA, 1.2PF; 5 082-2811, T&R	80009	152-0322-00
A62A1CR4103	152-0141-02			DIODE, SIG: ,ULTRA FAST; 40V, 150MA, 4NS, 2PF; 1N4 152, DO-35, T&R	80009	152-0141-02
A62A1CR5027	152-0322-00			DIODE, SIG: SCHKY, ;15V, 410MVF AT 1MA, 1.2PF; 5 082-2811, T&R	80009	152-0322-00
A62A1CR5033	152-0322-00			DIODE, SIG: SCHKY, ;15V, 410MVF AT 1MA, 1.2PF; 5 082-2811, T&R	80009	152-0322-00
A62A1CR5081	152-0141-02			DIODE, SIG: ,ULTRA FAST; 40V, 150MA, 4NS, 2PF; 1N4 152, DO-35, T&R	80009	152-0141-02
A62A1CR7103	152-0141-02			DIODE, SIG: ,ULTRA FAST; 40V, 150MA, 4NS, 2PF; 1N4 152, DO-35, T&R	80009	152-0141-02

Replaceable Electrical Parts
494A/494AP Service Vol.2

Component No.	Tektronix Part No.	Serial/Assembly No. Effective Dscont	Name & Description	Mfr. Code	Mfr. Part No.
A62A1CR8107	152-0141-02		DIODE, SIG: ,ULTRA FAST;40V,150MA,4NS,2PF;1N4152,DO-35,T&R	80009	152-0141-02
A62A1L1051	108-0395-00		COIL,RF:FIXED,64UH	80009	108-0395-00
A62A1L2011	108-0395-00		COIL,RF:FIXED,64UH	80009	108-0395-00
A62A1L2015	108-0443-00		COIL,RF:FIXED,23.5UH	80009	108-0443-00
A62A1L2025	108-0443-00		COIL,RF:FIXED,23.5UH	80009	108-0443-00
A62A1L2041	108-0443-00		COIL,RF:FIXED,23.5UH	80009	108-0443-00
A62A1L2052	108-0395-00		COIL,RF:FIXED,64UH	80009	108-0395-00
A62A1L2055	108-0443-00		COIL,RF:FIXED,23.5UH	80009	108-0443-00
A62A1L2071	108-0443-00		COIL,RF:FIXED,23.5UH	80009	108-0443-00
A62A1L2085	108-0443-00		COIL,RF:FIXED,23.5UH	80009	108-0443-00
A62A1L3041	108-0395-00		COIL,RF:FIXED,64UH	80009	108-0395-00
A62A1L3061	108-0395-00		COIL,RF:FIXED,64UH	80009	108-0395-00
A62A1L6011	108-0702-00		COIL,RF:FIXED,36UH	80009	108-0702-00
A62A1L8021	108-0443-00		COIL,RF:FIXED,23.5UH	80009	108-0443-00
A62A1Q1025	151-0192-00		TRANSISTOR, SIG: BIPOLAR, NPN; 25V, 100MA, 200MHZ ,AMPLIFIER; MPS6521, TO-92 EBC	80009	151-0192-00
A62A1Q1035	151-0192-00		TRANSISTOR, SIG: BIPOLAR, NPN; 25V, 100MA, 200MHZ ,AMPLIFIER; MPS6521, TO-92 EBC	80009	151-0192-00
A62A1Q1050	151-0192-00		TRANSISTOR, SIG: BIPOLAR, NPN; 25V, 100MA, 200MHZ ,AMPLIFIER; MPS6521, TO-92 EBC	80009	151-0192-00
A62A1Q1070	151-0192-00		TRANSISTOR, SIG: BIPOLAR, NPN; 25V, 100MA, 200MHZ ,AMPLIFIER; MPS6521, TO-92 EBC	80009	151-0192-00
A62A1Q1080	151-0192-00		TRANSISTOR, SIG: BIPOLAR, NPN; 25V, 100MA, 200MHZ ,AMPLIFIER; MPS6521, TO-92 EBC	80009	151-0192-00
A62A1Q1095	151-0192-00		TRANSISTOR, SIG: BIPOLAR, NPN; 25V, 100MA, 200MHZ ,AMPLIFIER; MPS6521, TO-92 EBC	80009	151-0192-00
A62A1Q2105	151-0192-00		TRANSISTOR, SIG: BIPOLAR, NPN; 25V, 100MA, 200MHZ ,AMPLIFIER; MPS6521, TO-92 EBC	80009	151-0192-00
A62A1Q3015	151-0192-00		TRANSISTOR, SIG: BIPOLAR, NPN; 25V, 100MA, 200MHZ ,AMPLIFIER; MPS6521, TO-92 EBC	80009	151-0192-00
A62A1Q3030	151-0192-00		TRANSISTOR, SIG: BIPOLAR, NPN; 25V, 100MA, 200MHZ ,AMPLIFIER; MPS6521, TO-92 EBC	80009	151-0192-00
A62A1Q3045	151-0192-00		TRANSISTOR, SIG: BIPOLAR, NPN; 25V, 100MA, 200MHZ ,AMPLIFIER; MPS6521, TO-92 EBC	80009	151-0192-00
A62A1Q3055	151-0192-00		TRANSISTOR, SIG: BIPOLAR, NPN; 25V, 100MA, 200MHZ ,AMPLIFIER; MPS6521, TO-92 EBC	80009	151-0192-00
A62A1Q3075	151-0192-00		TRANSISTOR, SIG: BIPOLAR, NPN; 25V, 100MA, 200MHZ ,AMPLIFIER; MPS6521, TO-92 EBC	80009	151-0192-00
A62A1Q3090	151-0192-00		TRANSISTOR, SIG: BIPOLAR, NPN; 25V, 100MA, 200MHZ ,AMPLIFIER; MPS6521, TO-92 EBC	80009	151-0192-00
A62A1Q3100	151-0192-00		TRANSISTOR, SIG: BIPOLAR, NPN; 25V, 100MA, 200MHZ ,AMPLIFIER; MPS6521, TO-92 EBC	80009	151-0192-00
A62A1Q3105	151-0192-00		TRANSISTOR, SIG: BIPOLAR, NPN; 25V, 100MA, 200MHZ ,AMPLIFIER; MPS6521, TO-92 EBC	80009	151-0192-00
A62A1Q4025	151-0333-00		TRANSISTOR, SIG: BIPOLAR, NPN; 15V, 50MA, 650MHZ, AMPLIFIER; MPS918/MPS3563, TO-92 EBC	80009	151-0333-00
A62A1Q4030	151-0221-00		TRANSISTOR, SIG: BIPOLAR, PNP; 12V, 80MA, SWITCHING; MPS4258, TO-92 EBC	80009	151-0221-00
A62A1Q4035	151-0221-00		TRANSISTOR, SIG: BIPOLAR, PNP; 12V, 80MA, SWITCHING; MPS4258, TO-92 EBC	80009	151-0221-00
A62A1Q4070	151-1059-00		TRANSISTOR, SIG: JFET, N-CH; 10V, 30MA(MIN), 30 OHM, 300MW; MPF4391, TO-92	04713	ORDER BY DESC
A62A1Q4075	151-1059-00		TRANSISTOR, SIG: JFET, N-CH; 10V, 30MA(MIN), 30 OHM, 300MW; MPF4391, TO-92	04713	ORDER BY DESC
A62A1Q4100	151-0192-00		TRANSISTOR, SIG: BIPOLAR, NPN; 25V, 100MA, 200MHZ ,AMPLIFIER; MPS6521, TO-92 EBC	80009	151-0192-00

Replaceable Electrical Parts
494A/494AP Service Vol.2

Component No.	Tektronix Part No.	Serial/Assembly No. Effective Dscont	Name & Description	Mfr. Code	Mfr. Part No.
A62A1Q5070	151-1059-00		TRANSISTOR, SIG: JFET, N-CH; 10V, 30MA(MIN), 30 0	04713	ORDER BY DESCR
A62A1Q5075	151-1059-00		HM, 300MW; MPF4391, TO-92		
A62A1Q5090	151-1059-00		TRANSISTOR, SIG: JFET, N-CH; 10V, 30MA(MIN), 30 0	04713	ORDER BY DESCR
A62A1Q5095	151-1059-00		HM, 300MW; MPF4391, TO-92		
A62A1Q6010	151-0192-00		TRANSISTOR, SIG: BIPOLAR, NPN; 25V, 100MA, 200MHZ	80009	151-0192-00
A62A1Q6090	151-0221-00		, AMPLIFIER; MPS6521, TO-92 EBC		
A62A1Q6095	151-0221-00		TRANSISTOR, SIG: BIPOLAR, PNP; 12V, 80MA, SWITCHI	80009	151-0221-00
A62A1Q6110	151-0221-00		NG; MPS4258, TO-92 EBC		
A62A1Q6115	151-0221-00		TRANSISTOR, SIG: BIPOLAR, PNP; 12V, 80MA, SWITCHI	80009	151-0221-00
A62A1Q7110	151-1059-00		NG; MPS4258, TO-92 EBC		
A62A1R1024	321-0155-00		TRANSISTOR, SIG: JFET, N-CH; 10V, 30MA(MIN), 30 0	04713	ORDER BY DESCR
A62A1R1035	321-0111-00		HM, 300MW; MPF4391, TO-92		
A62A1R1045	321-0111-00		RES, FXD, FILM: 402 OHM, 1%, 0.125W, TC=TO	07716	CEAD402R0F
A62A1R1056	321-0079-00		RES, FXD, FILM: 140 OHM, 1%, 0.125W, TC=TO	07716	CEAD140R0F
A62A1R1070	321-0325-00		RES, FXD, FILM: 140 OHM, 1%, 0.125W, TC=TO	07716	CEAD140R0F
A62A1R1076	321-0065-00		RES, FXD, FILM: 64.9 OHM, 1%, 0.125W, TC=TO	80009	321-0079-00
A62A1R1083	321-0325-00		RES, FXD, FILM: 23.7K OHM, 1%, 0.125W, TC=TO	07716	CEAD23701F
A62A1R1084	321-0325-00		RES, FXD, FILM: 23.7K OHM, 1%, 0.125W, TC=TO	07716	CEAD23701F
A62A1R1085	311-1277-00		RES, VAR, NONNW: TRMR, 100 OHM, 0.5W	80009	311-1277-00
A62A1R1086	321-0126-00		RES, FXD, FILM: 200 OHM, 1%, 0.125W, TC=TO	80009	321-0126-00
A62A1R1097	321-0325-00		RES, FXD, FILM: 23.7K OHM, 1%, 0.125W, TC=TO	07716	CEAD23701F
A62A1R1101	315-0470-00		RES, FXD, FILM: 47 OHM, 5%, 0.25W	80009	315-0470-00
A62A1R1111	321-0068-00		RES, FXD, FILM: 49.9 OHM, 0.1%, 0.125W, TC=TO	80009	321-0068-00
A62A1R1112	315-0680-00		RES, FXD, FILM: 68 OHM, 5%, 0.25W	80009	315-0680-00
A62A1R2023	321-0111-00		RES, FXD, FILM: 140 OHM, 1%, 0.125W, TC=TO	07716	CEAD140R0F
A62A1R2065	321-0276-00		RES, FXD, FILM: 7.32K OHM, 1%, 0.125W, TC=TO	80009	321-0276-00
A62A1R2066	321-0234-00		RES, FXD, FILM: 2.67K OHM, 1%, 0.125W, TC=TO	80009	321-0234-00
A62A1R2076	321-0253-00		RES, FXD, FILM: 4.22K OHM, 1%, 0.125W, TC=TO	19701	5033ED 4K 220F
A62A1R2078	321-0291-00		RES, FXD, FILM: 10.5K OHM, 1%, 0.125W, TC=TO	80009	321-0291-00
A62A1R2100	321-0187-00		RES, FXD, FILM: 866 OHM, 1%, 0.125W, TC=TO	07716	CEAD866R0F
A62A1R2101	321-0271-00		RES, FXD, FILM: 6.49K OHM, 1%, 0.125W, TC=TO	07716	CEAD64900F
A62A1R3020	307-0610-00		RES NTWK, FXD, FI: LOG AMP RES PACK	80009	307-0610-00
A62A1R3035	307-0610-00		RES NTWK, FXD, FI: LOG AMP RES PACK	80009	307-0610-00
A62A1R3050	307-0610-00		RES NTWK, FXD, FI: LOG AMP RES PACK	80009	307-0610-00
A62A1R3065	307-0610-00		RES NTWK, FXD, FI: LOG AMP RES PACK	80009	307-0610-00
A62A1R3080	307-0610-00		RES NTWK, FXD, FI: LOG AMP RES PACK	80009	307-0610-00
A62A1R3082	321-0294-00		RES, FXD, FILM: 11.3K OHM, 1%, 0.125W, TC=TO	80009	321-0294-00
A62A1R3092	315-0302-00		RES, FXD, FILM: 3K OHM, 5%, 0.25W	80009	315-0302-00
A62A1R3095	307-0610-00		RES NTWK, FXD, FI: LOG AMP RES PACK	80009	307-0610-00
A62A1R3099	315-0471-00		RES, FXD, FILM: 470 OHM, 5%, 0.25W	80009	315-0471-00
A62A1R3101	321-0187-00		RES, FXD, FILM: 866 OHM, 1%, 0.125W, TC=TO	07716	CEAD866R0F
A62A1R3102	321-0106-00		RES, FXD, FILM: 124 OHM 1%, 0.125W, TC=TO	80009	321-0106-00
A62A1R3105	321-0089-00		RES, FXD, FILM: 82.5 OHM, 1%, 0.125W, TC=TO	80009	321-0089-00
A62A1R3109	315-0241-00		RES, FXD, FILM: 240 OHM, 5%, 0.25W	80009	315-0241-00
A62A1R3110	315-0470-00		RES, FXD, FILM: 47 OHM, 5%, 0.25W	80009	315-0470-00
A62A1R3111	315-0101-00		RES, FXD, FILM: 100 OHM, 5%, 0.25W	80009	315-0101-00
A62A1R4010	307-0610-00		RES NTWK, FXD, FI: LOG AMP RES PACK	80009	307-0610-00
A62A1R4015	321-0111-00		RES, FXD, FILM: 140 OHM, 1%, 0.125W, TC=TO	07716	CEAD140R0F

Replaceable Electrical Parts
494A/494AP Service Vol.2

Component No.	Tektronix Part No.	Serial/Assembly No. Effective Dscont	Name & Description	Mfr. Code	Mfr. Part No.
A62A1R4020	311-1279-00		RES, VAR, NONNW: TRMR, 500 OHM, 0.5W	80009	311-1279-00
A62A1R4025	315-0302-00		RES, FXD, FILM: 3K OHM, 5%, 0.25W	80009	315-0302-00
A62A1R4026	315-0302-00		RES, FXD, FILM: 3K OHM, 5%, 0.25W	80009	315-0302-00
A62A1R4027	315-0560-00		RES, FXD, FILM: 56 OHM, 5%, 0.25W	80009	315-0560-00
A62A1R4031	315-0751-00		RES, FXD, FILM: 750 OHM, 5%, 0.25W	80009	315-0751-00
A62A1R4032	315-0910-00		RES, FXD, FILM: 91 OHM, 5%, 0.25W	80009	315-0910-00
A62A1R4034	315-0300-00		RES, FXD, FILM: 30 OHM, 5%, 0.25W	80009	315-0300-00
A62A1R4036	315-0300-00		RES, FXD, FILM: 30 OHM, 5%, 0.25W	80009	315-0300-00
A62A1R4038	321-0235-00		RES, FXD, FILM: 2.74K OHM, 1%, 0.125W, TC=TO	07716	CEAD27400F
A62A1R4039	321-0223-00		RES, FXD, FILM: 2.05K OHM, 1%, 0.125W, TC=TO	80009	321-0223-00
A62A1R4045	323-0126-00		RES, FXD, FILM: 200 OHM, 1%, 0.5W, TC=TO	75042	CECT0-2000F
A62A1R4046	301-0102-00		RES, FXD, CMPSN: 1K OHM, 5%, 0.50W	01121	EBI025
A62A1R4050	321-0041-00		RES, FXD, FILM: 26.1 OHM, 1%, 0.125W, TC=TO	80009	321-0041-00
A62A1R4051	315-0101-00		RES, FXD, FILM: 100 OHM, 5%, 0.25W	80009	315-0101-00
A62A1R4052	311-1245-00		RES, VAR, NONNW: TRMR, 10K OHM, 0.5W	80009	311-1245-00
A62A1R4061	315-0512-00		RES, FXD, FILM: 5.1K OHM, 5%, 0.25W	80009	315-0512-00
A62A1R4062	315-0512-00		RES, FXD, FILM: 5.1K OHM, 5%, 0.25W	80009	315-0512-00
A62A1R4064	315-0103-00		RES, FXD, FILM: 10K OHM, 5%, 0.25W	80009	315-0103-00
A62A1R4071	311-1245-00		RES, VAR, NONNW: TRMR, 10K OHM, 0.5W	80009	311-1245-00
A62A1R4072	321-0452-00		RES, FXD, FILM: 499K OHM, 1%, 0.125W, TC=TO	80009	321-0452-00
A62A1R4074	315-0103-00		RES, FXD, FILM: 10K OHM, 5%, 0.25W	80009	315-0103-00
A62A1R4081	311-1245-00		RES, VAR, NONNW: TRMR, 10K OHM, 0.5W	80009	311-1245-00
A62A1R4082	321-0330-00		RES, FXD, FILM: 26.7K OHM, 1%, 0.125W, TC=TO	07716	CEAD26701F
A62A1R4083	321-0424-00		RES, FXD, FILM: 255K OHM, 1%, 0.125W, TC=TO	07716	CEAD25502F
A62A1R4084	321-0431-00		RES, FXD, FILM: 301K OHM, 1%, 0.125W, TC=TO	07716	CEAD30102F
A62A1R4085	315-0102-00		RES, FXD, FILM: 1K OHM, 5%, 0.25W	80009	315-0102-00
A62A1R4091	315-0103-00		RES, FXD, FILM: 10K OHM, 5%, 0.25W	80009	315-0103-00
A62A1R4092	321-0431-00		RES, FXD, FILM: 301K OHM, 1%, 0.125W, TC=TO	07716	CEAD30102F
A62A1R4093	321-0324-00		RES, FXD, FILM: 23.2K OHM, 1%, 0.125W, TC=TO	07716	CEAD23201F
A62A1R4094	321-0243-00		RES, FXD, FILM: 3.32K OHM, 1%, 0.125W, TC=TO	80009	321-0243-00
A62A1R4095	315-0103-00		RES, FXD, FILM: 10K OHM, 5%, 0.25W	80009	315-0103-00
A62A1R4096	321-0385-00		RES, FXD, FILM: 100K OHM, 1%, 0.125W, TC=TO	80009	321-0385-00
A62A1R4097	321-0349-00		RES, FXD, FILM: 42.2K OHM, 1%, 0.125W, TC=TO	07716	CEAD42201F
A62A1R4098	315-0202-00		RES, FXD, FILM: 2K OHM, 5%, 0.25W	80009	315-0202-00
A62A1R4103	315-0362-00		RES, FXD, FILM: 3.6K OHM, 5%, 0.25W	80009	315-0362-00
A62A1R4105	321-0172-00		RES, FXD, FILM: 604 OHM, 1%, 0.125W, TC=TO	80009	321-0172-00
A62A1R4107	321-0171-00		RES, FXD, FILM: 590 OHM, 1%, 0.125W, TC=TO	80009	321-0171-00
A62A1R4109	321-0170-00		RES, FXD, FILM: 576 OHM, 1%, 0.125W, TC=TO	07716	CEAD576R0F
A62A1R5015	321-0139-00		RES, FXD, FILM: 274 OHM, 1%, 0.125W, TC=TO	07716	CEAD274R0F
A62A1R5020	321-0193-00		RES, FXD, FILM: 1K OHM, 1%, 0.125W, TC=TO	80009	321-0193-00
A62A1R5021	321-0389-00		RES, FXD, FILM: 110K OHM, 1%, 0.125W, TC=TO	07716	CEAD11002F
A62A1R5022	321-0423-00		RES, FXD, FILM: 249K OHM, 1%, 0.125W, TC=TO	80009	321-0423-00
A62A1R5024	315-0510-00		RES, FXD, FILM: 51 OHM, 5%, 0.25W	80009	315-0510-00
A62A1R5025	315-0751-00		RES, FXD, FILM: 750 OHM, 5%, 0.25W	80009	315-0751-00
A62A1R5027	321-0126-00		RES, FXD, FILM: 200 OHM, 1%, 0.125W, TC=TO	80009	321-0126-00
A62A1R5028	321-0164-00		RES, FXD, FILM: 499 OHM, 1%, 0.125W, TC=TO	19701	5043ED499R0F
A62A1R5029	321-0268-00		RES, FXD, FILM: 6.04K OHM, 1%, 0.125W, TC=TO	57688	CRB14FXE6.04KOHM
A62A1R5031	315-0181-00		RES, FXD, FILM: 180 OHM, 5%, 0.25W	80009	315-0181-00
A62A1R5032	321-0289-00		RES, FXD, FILM: 10.0K OHM, 1%, 0.125W, TC=TO	57688	FXE10K0
A62A1R5033	321-0126-00		RES, FXD, FILM: 200 OHM, 1%, 0.125W, TC=TO	80009	321-0126-00
A62A1R5034	321-0193-00		RES, FXD, FILM: 1K OHM, 1%, 0.125W, TC=TO	80009	321-0193-00
A62A1R5082	321-0290-00		RES, FXD, FILM: 10.2K OHM, 1%, 0.125W, TC=TO	80009	321-0290-00
A62A1R5084	321-0239-00		RES, FXD, FILM: 3.01K OHM, 1%, 0.125W, TC=TO	80009	321-0239-00
A62A1R5085	315-0103-00		RES, FXD, FILM: 10K OHM, 5%, 0.25W	80009	315-0103-00
A62A1R5086	315-0102-00		RES, FXD, FILM: 1K OHM, 5%, 0.25W	80009	315-0102-00
A62A1R5088	321-0309-00		RES, FXD, FILM: 16.2K OHM, 1%, 0.125W, TC=TO	80009	321-0309-00
A62A1R5089	315-0473-00		RES, FXD, FILM: 47K OHM, 5%, 0.25W	80009	315-0473-00
A62A1R5103	321-0348-00		RES, FXD, FILM: 41.2K OHM, 1%, 0.125W, TC=TO	80009	321-0348-00

Replaceable Electrical Parts
494A/494AP Service Vol.2

Component No.	Tektronix Part No.	Serial/Assembly No. Effective Discnt	Name & Description	Mfr. Code	Mfr. Part No.
A62A1R5105	321-0299-00		RES,FXD,FILM:12.7K OHM,1%,0.125W,TC=TO	80009	321-0299-00
A62A1R5107	321-0236-00		RES,FXD,FILM:2.80K OHM,1%,0.125W,TC=TO	07716	CEAD28000F
A62A1R5109	315-0473-00		RES,FXD,FILM:47K OHM,5%,0.25W	80009	315-0473-00
A62A1R5111	321-0150-00		RES,FXD,FILM:357 OHM,1%,0.125W,TC=TO	07716	CEAD357R0F
A62A1R6023	315-0273-00		RES,FXD,FILM:27K OHM,5%,0.25W	80009	315-0273-00
A62A1R6024	307-0106-00		RES,FXD,CMPSN:4.7 OHM,5%,0.25W	01121	CB4765
A62A1R6029	315-0510-00		RES,FXD,FILM:51 OHM,5%,0.25W	80009	315-0510-00
A62A1R6072	315-0100-00		RES,FXD,FILM:10 OHM,5%,0.25W	19701	5043CX10RR00J
A62A1R6073	321-0318-00		RES,FXD,FILM:20.0K OHM,1%,0.125W,TC=TO	80009	321-0318-00
A62A1R6074	321-0347-00		RES,FXD,FILM:40.2K OHM,1%,0.125W,TC=TO	80009	321-0347-00
A62A1R6079	315-0103-00		RES,FXD,FILM:10K OHM,5%,0.25W	80009	315-0103-00
A62A1R6080	321-0376-00		RES,FXD,FILM:80.6K OHM,1%,0.125W,TC=TO	80009	321-0376-00
A62A1R6081	321-0164-00		RES,FXD,FILM:499 OHM,1%,0.125W,TC=TO	19701	5043ED499R0F
A62A1R6082	321-0289-00		RES,FXD,FILM:10.0K OHM,1%,0.125W,TC=TO	57668	FXE10K0
A62A1R6087	315-0103-00		RES,FXD,FILM:10K OHM,5%,0.25W	80009	315-0103-00
A62A1R6091	321-0389-00		RES,FXD,FILM:110K OHM,1%,0.125W,TC=TO	07716	CEAD11002F
A62A1R6107	315-0102-00		RES,FXD,FILM:1K OHM,5%,0.25W	80009	315-0102-00
A62A1R6108	321-0289-00		RES,FXD,FILM:10.0K OHM,1%,0.125W,TC=TO	57668	FXE10K0
A62A1R6111	321-0300-00		RES,FXD,FILM:13.0K OHM,1%,0.125W,TC=TO	07716	CEAD13001F
A62A1R6113	315-0272-00		RES,FXD,FILM:2.7K OHM,5%,0.25W	80009	315-0272-00
A62A1R7074	315-0103-00		RES,FXD,FILM:10K OHM,5%,0.25W	80009	315-0103-00
A62A1R7075	315-0103-00		RES,FXD,FILM:10K OHM,5%,0.25W	80009	315-0103-00
A62A1R7083	307-0106-00		RES,FXD,CMPSN:4.7 OHM,5%,0.25W	01121	CB4765
A62A1R7085	321-0242-00		RES,FXD,FILM:3.24K OHM,1%,0.125W,TC=TO	80009	321-0242-00
A62A1R7086	315-0470-00		RES,FXD,FILM:47 OHM,5%,0.25W	80009	315-0470-00
A62A1R7087	315-0101-00		RES,FXD,FILM:100 OHM,5%,0.25W	80009	315-0101-00
A62A1R7090	315-0102-00		RES,FXD,FILM:1K OHM,5%,0.25W	80009	315-0102-00
A62A1R7092	315-0103-00		RES,FXD,FILM:10K OHM,5%,0.25W	80009	315-0103-00
A62A1R7094	321-0321-00		RES,FXD,FILM:21.5K OHM,1%,0.125W,TC=TO	07716	CEAD21501F
A62A1R7095	315-0470-00		RES,FXD,FILM:47 OHM,5%,0.25W	80009	315-0470-00
A62A1R7096	321-0387-00		RES,FXD,FILM:105K OHM,1%,0.125W,TC=TO	07716	CEAD10502F
A62A1R7097	321-0423-00		RES,FXD,FILM:249K OHM,1%,0.125W,TC=TO	80009	321-0423-00
A62A1R7099	321-0406-00		RES,FXD,FILM:165K OHM,1%,0.125W,TC=TO	07716	CEAD16502F
A62A1R7105	315-0753-00		RES,FXD,FILM:75K OHM,5%,0.25W	80009	315-0753-00
A62A1R7107	315-0102-00		RES,FXD,FILM:1K OHM,5%,0.25W	80009	315-0102-00
A62A1R7111	315-0103-00		RES,FXD,FILM:10K OHM,5%,0.25W	80009	315-0103-00
A62A1R8020	321-0296-00		RES,FXD,FILM:11.8K OHM,1%,0.125W,TC=TO	07716	CEAD11801F
A62A1R8021	321-0296-00		RES,FXD,FILM:11.8K OHM,1%,0.125W,TC=TO	07716	CEAD11801F
A62A1R8031	307-0106-00		RES,FXD,CMPSN:4.7 OHM,5%,0.25W	01121	CB4765
A62A1R8034	307-0106-00		RES,FXD,CMPSN:4.7 OHM,5%,0.25W	01121	CB4765
A62A1R8103	315-0105-00		RES,FXD,FILM:1M OHM,5%,0.25W	80009	315-0105-00
A62A1R8106	315-0754-00		RES,FXD,FILM:750K OHM,5%,0.25W,MI	80009	315-0754-00
A62A1U4090	155-0116-00		MICROCKT,LINEAR:QUAD OPNL AMPL	80009	155-0116-00
A62A1U5041	156-0509-03		IC,CONVERTER:TTL,D/A;8-BIT,SCRN;1408,DIP16.3	04713	MC1408L8DS
A62A1U5060	156-0411-00		IC,LINEAR:BIPOLAR,COMPARATOR;QUAD,SINGLE SUPPLY,300NS;LM339N,DIP14.3	80009	156-0411-00
A62A1U5070	156-0385-00		IC,DIGITAL:LSTTL,GATES;HEX INV;74LS04,DIP14.3,TUBE	80009	156-0385-00
A62A1U6040	156-0913-00		IC,DIGITAL:LSTTL,FLIP FLOP;OCTAL D-TYPE,ENABLE;74LS377,DIP20.3,TUBE	80009	156-0913-00
A62A1U6050	156-0913-00		IC,DIGITAL:LSTTL,FLIP FLOP;OCTAL D-TYPE,ENABLE;74LS377,DIP20.3,TUBE	80009	156-0913-00
A62A1U6060	156-0411-00		IC,LINEAR:BIPOLAR,COMPARATOR;QUAD,SINGLE SUPPLY,300NS;LM339N,DIP14.3	80009	156-0411-00
A62A1U6070	156-0469-00		IC,DIGITAL:LSTTL,DEMUX/DECODER;3-TO-8 DECODER;74LS138,DIP16.3,TUBE	80009	156-0469-00

Replaceable Electrical Parts
494A/494AP Service Vol.2

Component No.	Tektronix Part No.	Serial/Assembly No. Effective	Discount	Name & Description	Mfr. Code	Mfr. Part No.
A62A1W1023	131-0566-00			BUS, CONDUCTOR: DUMMY RES, 0.094 OD X 0.225 L	80009	131-0566-00
A62A1W2013	131-0566-00			BUS, CONDUCTOR: DUMMY RES, 0.094 OD X 0.225 L	80009	131-0566-00
A64	672-0162-01	B010100	B010134	CIRCUIT BD ASSY: DEFL AMP	80009	672-0162-01
A64	672-0162-02	B010135		CIRCUIT BD ASSY: DEFL AMP	80009	672-0162-02
A64A1	670-8083-01	B010100	B010134	CIRCUIT BD ASSY: DEFLECTION AMP	80009	670-8083-01
A64A1	670-8083-02	B010135		CIRCUIT BD ASSY: DEFL AMP	80009	670-8083-02
A64A1C1018	283-0006-00			CAP, FXD, CER DI: 0.02UF, +80-20%, 500V	59660	0841545Z5V00203Z
A64A1C1023	283-0203-00			CAP, FXD, CER DI: 0.47UF, 20%, 50V	80009	283-0203-00
A64A1C1049	283-0203-00			CAP, FXD, CER DI: 0.47UF, 20%, 50V	80009	283-0203-00
A64A1C2022	283-0006-00			CAP, FXD, CER DI: 0.02UF, +80-20%, 500V	59660	0841545Z5V00203Z
A64A1C2037	283-0010-00			CAP, FXD, CER DI: 0.05UF, +80-20%, 50V	05397	C330C503Z5U1CA
A64A1C2047	283-0317-00			CAP, FXD, CER DI: 1PF, +/-0.1PF, 500V	59660	861518C0K0109B
A64A1C2055	283-0140-00			CAP, FXD, CER DI: 4.7PF, +/-0.25PF, 50V	80009	283-0140-00
A64A1C2060	283-0167-00	B010135		CAP, FXD, CER DI: 0.1UF, 10%, 100V	80009	283-0167-00
A64A1C2062	283-0167-00	B010135		CAP, FXD, CER DI: 0.1UF, 10%, 100V	80009	283-0167-00
A64A1C2066	283-0140-00			CAP, FXD, CER DI: 4.7PF, +/-0.25PF, 50V	80009	283-0140-00
A64A1C2073	283-0010-00			CAP, FXD, CER DI: 0.05UF, +80-20%, 50V	05397	C330C503Z5U1CA
A64A1C2078	283-0317-00			CAP, FXD, CER DI: 1PF, +/-0.1PF, 500V	59660	861518C0K0109B
A64A1C2083	283-0006-00			CAP, FXD, CER DI: 0.02UF, +80-20%, 500V	59660	0841545Z5V00203Z
A64A1C2087	283-0006-00			CAP, FXD, CER DI: 0.02UF, +80-20%, 500V	59660	0841545Z5V00203Z
A64A1C2101	283-0006-00			CAP, FXD, CER DI: 0.02UF, +80-20%, 500V	59660	0841545Z5V00203Z
A64A1C2103	283-0006-00			CAP, FXD, CER DI: 0.02UF, +80-20%, 500V	59660	0841545Z5V00203Z
A64A1C2106	283-0317-00			CAP, FXD, CER DI: 1PF, +/-0.1PF, 500V	59660	861518C0K0109B
A64A1C3021	283-0317-00			CAP, FXD, CER DI: 1PF, +/-0.1PF, 500V	59660	861518C0K0109B
A64A1C3039	283-0006-00			CAP, FXD, CER DI: 0.02UF, +80-20%, 500V	59660	0841545Z5V00203Z
A64A1C3051	283-0006-00			CAP, FXD, CER DI: 0.02UF, +80-20%, 500V	59660	0841545Z5V00203Z
A64A1C4057	281-0226-00			CAP, VAR, PLASTIC: 4-38PF, 100V	80009	281-0226-00
A64A1C4061	281-0226-00			CAP, VAR, PLASTIC: 4-38PF, 100V	80009	281-0226-00
A64A1C5021	281-0226-00			CAP, VAR, PLASTIC: 4-38PF, 100V	80009	281-0226-00
A64A1C5033	283-0111-00			CAP, FXD, CER DI: 0.1UF, 20%, 50V	80009	283-0111-00
A64A1C5058	283-0111-00			CAP, FXD, CER DI: 0.1UF, 20%, 50V	80009	283-0111-00
A64A1C5089	283-0111-00			CAP, FXD, CER DI: 0.1UF, 20%, 50V	80009	283-0111-00
A64A1C5104	281-0226-00			CAP, VAR, PLASTIC: 4-38PF, 100V	80009	281-0226-00
A64A1C6033	283-0189-00			CAP, FXD, CER DI: 0.1UF, 20%, 400V	04222	SR508C104MAA
A64A1C6037	283-0189-00			CAP, FXD, CER DI: 0.1UF, 20%, 400V	04222	SR508C104MAA
A64A1C6038	283-0167-00	B010135		CAP, FXD, CER DI: 0.1UF, 10%, 100V	80009	283-0167-00
A64A1C6065	283-0167-00	B010135		CAP, FXD, CER DI: 0.1UF, 10%, 100V	80009	283-0167-00
A64A1C6081	281-0811-00			CAP, FXD, CER DI: 10PF, 10%, 100V	04222	SA102A100KAA
A64A1C7015	283-0065-00			CAP, FXD, CER DI: 0.001UF, 5%, 50V	80009	283-0065-00
A64A1C7061	283-0177-00			CAP, FXD, CER DI: 1UF, +80-20%, 25V	04222	SR303E105ZAA
A64A1C7065	283-0167-00	B010135		CAP, FXD, CER DI: 0.1UF, 10%, 100V	80009	283-0167-00
A64A1C7071	283-0177-00			CAP, FXD, CER DI: 1UF, +80-20%, 25V	04222	SR303E105ZAA
A64A1C7073	283-0177-00			CAP, FXD, CER DI: 1UF, +80-20%, 25V	04222	SR303E105ZAA
A64A1C7074	283-0177-00			CAP, FXD, CER DI: 1UF, +80-20%, 25V	04222	SR303E105ZAA
A64A1C7088	283-0177-00			CAP, FXD, CER DI: 1UF, +80-20%, 25V	04222	SR303E105ZAA
A64A1C7093	283-0177-00			CAP, FXD, CER DI: 1UF, +80-20%, 25V	04222	SR303E105ZAA
A64A1CR4051	152-0141-02			DIODE, SIG: , ULTRA FAST; 40V, 150MA, 4NS, 2PF; 1N4 152, DO-35, T&R	80009	152-0141-02
A64A1CR4052	152-0141-02			DIODE, SIG: , ULTRA FAST; 40V, 150MA, 4NS, 2PF; 1N4 152, DO-35, T&R	80009	152-0141-02
A64A1CR4056	152-0141-02			DIODE, SIG: , ULTRA FAST; 40V, 150MA, 4NS, 2PF; 1N4 152, DO-35, T&R	80009	152-0141-02
A64A1CR4058	152-0141-02			DIODE, SIG: , ULTRA FAST; 40V, 150MA, 4NS, 2PF; 1N4 152, DO-35, T&R	80009	152-0141-02
A64A1CR4063	152-0141-02			DIODE, SIG: , ULTRA FAST; 40V, 150MA, 4NS, 2PF; 1N4 152, DO-35, T&R	80009	152-0141-02
A64A1CR4064	152-0141-02			DIODE, SIG: , ULTRA FAST; 40V, 150MA, 4NS, 2PF; 1N4 152, DO-35, T&R	80009	152-0141-02

Replaceable Electrical Parts
494A/494AP Service Vol.2

Component No.	Tektronix	Serial/Assembly No.		Name & Description	Mfr.	Mfr. Part No.
	Part No.	Effective	Discont		Code	
A64A1CR5054	152-0141-02			DIODE, SIG: ,ULTRA FAST;40V,150MA,4NS,2PF;1N4152,DO-35,T&R	80009	152-0141-02
A64A1CR5055	152-0141-02			DIODE, SIG: ,ULTRA FAST;40V,150MA,4NS,2PF;1N4152,DO-35,T&R	80009	152-0141-02
A64A1L7061	108-0395-00			COIL, RF: FIXED, 64UH	80009	108-0395-00
A64A1L7069	108-0395-00			COIL, RF: FIXED, 64UH	80009	108-0395-00
A64A1L7081	108-0395-00			COIL, RF: FIXED, 64UH	80009	108-0395-00
A64A1L7088	108-0395-00			COIL, RF: FIXED, 64UH	80009	108-0395-00
A64A1Q1024	151-0694-01			TRANSISTOR: SCREENED	80009	151-0694-01
A64A1Q1031	151-0693-01			TRANSISTOR: BURN-IN	80009	151-0693-01
A64A1Q1043	151-0693-01			TRANSISTOR: BURN-IN	80009	151-0693-01
A64A1Q1049	151-0694-01			TRANSISTOR: SCREENED	80009	151-0694-01
A64A1Q1072	151-0694-01			TRANSISTOR: SCREENED	80009	151-0694-01
A64A1Q1095	151-0694-01			TRANSISTOR: SCREENED	80009	151-0694-01
A64A1Q2078	151-0693-01			TRANSISTOR: BURN-IN	80009	151-0693-01
A64A1Q2096	151-0693-01			TRANSISTOR: BURN-IN	80009	151-0693-01
A64A1Q4017	151-0220-00			TRANSISTOR, SIG: BIPOLAR, PNP; 40V, 200MA, 400MHZ ,AMPLIFIER; 2N3906(SEL), TO-92 EBC	80009	151-0220-00
A64A1Q4022	151-0220-00			TRANSISTOR, SIG: BIPOLAR, PNP; 40V, 200MA, 400MHZ ,AMPLIFIER; 2N3906(SEL), TO-92 EBC	80009	151-0220-00
A64A1Q4025	151-0261-00			TRANSISTOR, SIG: BIPOLAR, PNP; 60V, 50MA, 100MHZ, AMPLIFIER, TWO DIE DUAL; 2N3810, TO-77	80009	151-0261-00
A64A1Q4026	151-0302-00			TRANSISTOR, SIG: BIPOLAR, NPN; 40V, 800MA, 300MHZ ,AMPLIFIER; 2N2222A, TO-18	80009	151-0302-00
A64A1Q4035	151-0302-00			TRANSISTOR, SIG: BIPOLAR, NPN; 40V, 800MA, 300MHZ ,AMPLIFIER; 2N2222A, TO-18	80009	151-0302-00
A64A1Q4038	151-0261-00			TRANSISTOR, SIG: BIPOLAR, PNP; 60V, 50MA, 100MHZ, AMPLIFIER, TWO DIE DUAL; 2N3810, TO-77	80009	151-0261-00
A64A1Q4042	151-0220-00			TRANSISTOR, SIG: BIPOLAR, PNP; 40V, 200MA, 400MHZ ,AMPLIFIER; 2N3906(SEL), TO-92 EBC	80009	151-0220-00
A64A1Q4047	151-0220-00			TRANSISTOR, SIG: BIPOLAR, PNP; 40V, 200MA, 400MHZ ,AMPLIFIER; 2N3906(SEL), TO-92 EBC	80009	151-0220-00
A64A1Q4077	151-0220-00			TRANSISTOR, SIG: BIPOLAR, PNP; 40V, 200MA, 400MHZ ,AMPLIFIER; 2N3906(SEL), TO-92 EBC	80009	151-0220-00
A64A1Q4078	151-0220-00			TRANSISTOR, SIG: BIPOLAR, PNP; 40V, 200MA, 400MHZ ,AMPLIFIER; 2N3906(SEL), TO-92 EBC	80009	151-0220-00
A64A1Q4083	151-0261-00			TRANSISTOR, SIG: BIPOLAR, PNP; 60V, 50MA, 100MHZ, AMPLIFIER, TWO DIE DUAL; 2N3810, TO-77	80009	151-0261-00
A64A1Q4084	151-0220-00			TRANSISTOR, SIG: BIPOLAR, PNP; 40V, 200MA, 400MHZ ,AMPLIFIER; 2N3906(SEL), TO-92 EBC	80009	151-0220-00
A64A1Q4088	151-0302-00			TRANSISTOR, SIG: BIPOLAR, NPN; 40V, 800MA, 300MHZ ,AMPLIFIER; 2N2222A, TO-18	80009	151-0302-00
A64A1Q4098	151-0302-00			TRANSISTOR, SIG: BIPOLAR, NPN; 40V, 800MA, 300MHZ ,AMPLIFIER; 2N2222A, TO-18	80009	151-0302-00
A64A1Q4101	151-0261-00			TRANSISTOR, SIG: BIPOLAR, PNP; 60V, 50MA, 100MHZ, AMPLIFIER, TWO DIE DUAL; 2N3810, TO-77	80009	151-0261-00
A64A1Q4102	151-0220-00			TRANSISTOR, SIG: BIPOLAR, PNP; 40V, 200MA, 400MHZ ,AMPLIFIER; 2N3906(SEL), TO-92 EBC	80009	151-0220-00
A64A1Q4108	151-0220-00			TRANSISTOR, SIG: BIPOLAR, PNP; 40V, 200MA, 400MHZ ,AMPLIFIER; 2N3906(SEL), TO-92 EBC	80009	151-0220-00
A64A1R1022	315-0470-00			RES, FXD, FILM: 47 OHM, 5%, 0.25W	80009	315-0470-00
A64A1R1023	315-0392-00			RES, FXD, FILM: 3.9K OHM, 5%, 0.25W	80009	315-0392-00
A64A1R1024	315-0912-00			RES, FXD, FILM: 9.1K OHM, 5%, 0.25W	80009	315-0912-00
A64A1R1031	315-0102-00			RES, FXD, FILM: 1K OHM, 5%, 0.25W	80009	315-0102-00
A64A1R1034	315-0470-00			RES, FXD, FILM: 47 OHM, 5%, 0.25W	80009	315-0470-00
A64A1R1044	315-0102-00			RES, FXD, FILM: 1K OHM, 5%, 0.25W	80009	315-0102-00
A64A1R1045	315-0470-00			RES, FXD, FILM: 47 OHM, 5%, 0.25W	80009	315-0470-00
A64A1R1049	315-0392-00			RES, FXD, FILM: 3.9K OHM, 5%, 0.25W	80009	315-0392-00

Replaceable Electrical Parts
494A/494AP Service Vol.2

Component No.	Tektronix Part No.	Serial/Assembly No. Effective Dscnt	Name & Description	Mfr. Code	Mfr. Part No.
A64A1R1052	315-0912-00		RES, FXD, FILM: 9.1K OHM, 5%, 0.25W	80009	315-0912-00
A64A1R1055	311-1245-00		RES, VAR, NONMW: TRMR, 10K OHM, 0.5W	80009	311-1245-00
A64A1R1066	311-1245-00		RES, VAR, NONMW: TRMR, 10K OHM, 0.5W	80009	311-1245-00
A64A1R1081	315-0102-00		RES, FXD, FILM: 1K OHM, 5%, 0.25W	80009	315-0102-00
A64A1R1082	315-0470-00		RES, FXD, FILM: 47 OHM, 5%, 0.25W	80009	315-0470-00
A64A1R1084	315-0751-00		RES, FXD, FILM: 750 OHM, 5%, 0.25W	80009	315-0751-00
A64A1R1085	315-0472-00		RES, FXD, FILM: 4.7K OHM, 5%, 0.25W	80009	315-0472-00
A64A1R1087	315-0751-00		RES, FXD, FILM: 750 OHM, 5%, 0.25W	80009	315-0751-00
A64A1R1102	315-0472-00		RES, FXD, FILM: 4.7K OHM, 5%, 0.25W	80009	315-0472-00
A64A1R1103	315-0102-00		RES, FXD, FILM: 1K OHM, 5%, 0.25W	80009	315-0102-00
A64A1R1104	315-0470-00		RES, FXD, FILM: 47 OHM, 5%, 0.25W	80009	315-0470-00
A64A1R2025	321-0229-00		RES, FXD, FILM: 2.37K OHM, 1%, 0.125W, TC=TO	80009	321-0229-00
A64A1R2057	321-0372-00		RES, FXD, FILM: 73.2K OHM, 1%, 0.125W, TC=TO	07716	CEAD73201F
A64A1R2059	321-0415-00		RES, FXD, FILM: 205K OHM, 1%, 0.125W, TC=TO	80009	321-0415-00
A64A1R2062	321-0425-00		RES, FXD, FILM: 261K OHM, 1%, 0.125W, TC=TO	07716	CEAD26102F
A64A1R2066	321-0380-00		RES, FXD, FILM: 88.7K OHM, 1%, 0.125W, TC=TO	07716	CEAD88701F
A64A1R2076	315-0470-00		RES, FXD, FILM: 47 OHM, 5%, 0.25W	80009	315-0470-00
A64A1R2109	323-0620-00		RES, FXD, FILM: 800K OHM, 1%, 0.5W, TC=TO	19701	5053R08000KOF
A64A1R3023	321-0229-00		RES, FXD, FILM: 2.37K OHM, 1%, 0.125W, TC=TO	80009	321-0229-00
A64A1R3027	301-0624-00		RES, FXD, FILM: 620K OHM, 5%, 0.5W	01121	EB6245
A64A1R3031	301-0624-00		RES, FXD, FILM: 620K OHM, 5%, 0.5W	01121	EB6245
A64A1R3035	321-0229-00		RES, FXD, FILM: 2.37K OHM, 1%, 0.125W, TC=TO	80009	321-0229-00
A64A1R3037	321-0229-00		RES, FXD, FILM: 2.37K OHM, 1%, 0.125W, TC=TO	80009	321-0229-00
A64A1R3045	323-0620-00		RES, FXD, FILM: 800K OHM, 1%, 0.5W, TC=TO	19701	5053R08000KOF
A64A1R3069	315-0242-00		RES, FXD, FILM: 2.4K OHM, 5%, 0.25W	80009	315-0242-00
A64A1R3084	321-0229-00		RES, FXD, FILM: 2.37K OHM, 1%, 0.125W, TC=TO	80009	321-0229-00
A64A1R3086	321-0229-00		RES, FXD, FILM: 2.37K OHM, 1%, 0.125W, TC=TO	80009	321-0229-00
A64A1R3088	323-0620-00		RES, FXD, FILM: 800K OHM, 1%, 0.5W, TC=TO	19701	5053R08000KOF
A64A1R3089	303-0304-00		RES, FXD, CMPSN: 300K OHM, 5%, 1W	01121	6B3045
A64A1R3091	321-0378-00		RES, FXD, FILM: 84.5K OHM, 1%, 0.125W, TC=TO	07716	CEAD4501F
A64A1R3098	303-0304-00		RES, FXD, CMPSN: 300K OHM, 5%, 1W	01121	6B3045
A64A1R3107	321-0378-00		RES, FXD, FILM: 84.5K OHM, 1%, 0.125W, TC=TO	07716	CEAD4501F
A64A1R3117	315-0302-00		RES, FXD, FILM: 3K OHM, 5%, 0.25W	80009	315-0302-00
A64A1R4016	323-0620-00		RES, FXD, FILM: 800K OHM, 1%, 0.5W, TC=TO	19701	5053R08000KOF
A64A1R4019	321-0378-00		RES, FXD, FILM: 84.5K OHM, 1%, 0.125W, TC=TO	07716	CEAD4501F
A64A1R4021	315-0302-00		RES, FXD, FILM: 3K OHM, 5%, 0.25W	80009	315-0302-00
A64A1R4033	321-0378-00		RES, FXD, FILM: 84.5K OHM, 1%, 0.125W, TC=TO	07716	CEAD84501F
A64A1R4048	315-0242-00		RES, FXD, FILM: 2.4K OHM, 5%, 0.25W	80009	315-0242-00
A64A1R4049	321-0347-00		RES, FXD, FILM: 40.2K OHM, 1%, 0.125W, TC=TO	80009	321-0347-00
A64A1R4051	321-0286-00		RES, FXD, FILM: 9.31K OHM, 1%, 0.125W, TC=TO	80009	321-0286-00
A64A1R4052	321-0318-00		RES, FXD, FILM: 20.0K OHM, 1%, 0.125W, TC=TO	80009	321-0318-00
A64A1R4059	321-0379-00		RES, FXD, FILM: 86.6K OHM, 1%, 0.125W, TC=TO	07716	CEAD86601F
A64A1R4061	321-0280-00		RES, FXD, FILM: 8.06K OHM, 1%, 0.125W, TC=TO	80009	321-0280-00
A64A1R4062	321-0286-00		RES, FXD, FILM: 9.31K OHM, 1%, 0.125W, TC=TO	80009	321-0286-00
A64A1R4064	321-0318-00		RES, FXD, FILM: 20.0K OHM, 1%, 0.125W, TC=TO	80009	321-0318-00
A64A1R4065	321-0416-00		RES, FXD, FILM: 210K OHM, 1%, 0.125W, TC=TO	07716	CEAD21002F
A64A1R4067	321-0282-00		RES, FXD, FILM: 8.45K OHM, 1%, 0.125W, TC=TO	07716	CFAD84500F
A64A1R4069	321-0416-00		RES, FXD, FILM: 210K OHM, 1%, 0.125W, TC=TO	07716	CEAD21002F
A64A1R4071	321-0347-00		RES, FXD, FILM: 40.2K OHM, 1%, 0.125W, TC=TO	80009	321-0347-00
A64A1R4072	321-0290-00		RES, FXD, FILM: 10.2K OHM, 1%, 0.125W, TC=TO	80009	321-0290-00
A64A1R4078	315-0102-00		RES, FXD, FILM: 1K OHM, 5%, 0.25W	80009	315-0102-00
A64A1R4101	321-0229-00		RES, FXD, FILM: 2.37K OHM, 1%, 0.125W, TC=TO	80009	321-0229-00
A64A1R4103	321-0229-00		RES, FXD, FILM: 2.37K OHM, 1%, 0.125W, TC=TO	80009	321-0229-00
A64A1R5023	315-0102-00		RES, FXD, FILM: 1K OHM, 5%, 0.25W	80009	315-0102-00
A64A1R5025	315-0103-00		RES, FXD, FILM: 10K OHM, 5%, 0.25W	80009	315-0103-00
A64A1R5027	315-0203-00		RES, FXD, FILM: 20K OHM, 5%, 0.25W	80009	315-0203-00
A64A1R5029	315-0102-00		RES, FXD, FILM: 1K OHM, 5%, 0.25W	80009	315-0102-00
A64A1R5035	315-0101-00		RES, FXD, FILM: 100 OHM, 5%, 0.25W	80009	315-0101-00

Replaceable Electrical Parts
494A/494AP Service Vol.2

Component No.	Tektronix Part No.	Serial/Assembly No. Effective Dscont	Name & Description	Mfr. Code	Mfr. Part No.
A64A1R5037	315-0102-00		RES,FXD,FILM:1K OHM,5%,0.25W	80009	315-0102-00
A64A1R5039	315-0103-00		RES,FXD,FILM:10K OHM,5%,0.25W	80009	315-0103-00
A64A1R5041	315-0203-00		RES,FXD,FILM:20K OHM,5%,0.25W	80009	315-0203-00
A64A1R5042	315-0102-00		RES,FXD,FILM:1K OHM,5%,0.25W	80009	315-0102-00
A64A1R5049	321-0420-00		RES,FXD,FILM:232K OHM,1%,0.125W,TC=TO	07716	CEAD23202F
A64A1R5053	321-0335-00		RES,FXD,FILM:30.1K OHM,1%,0.125W,TC=TO	80009	321-0335-00
A64A1R5057	321-0412-00		RES,FXD,FILM:191K OHM,1%,0.125W,TC=TO	07716	CEAD19102F
A64A1R5058	321-0215-00		RES,FXD,FILM:1.69K OHM,1%,0.125W,TC=TO	07716	CEAD16900F
A64A1R5059	321-0412-00		RES,FXD,FILM:191K OHM,1%,0.125W,TC=TO	07716	CEAD19102F
A64A1R5062	321-0379-00		RES,FXD,FILM:86.6K OHM,1%,0.125W,TC=TO	07716	CEAD86601F
A64A1R5081	315-0103-00		RES,FXD,FILM:10K OHM,5%,0.25W	80009	315-0103-00
A64A1R5082	315-0103-00		RES,FXD,FILM:10K OHM,5%,0.25W	80009	315-0103-00
A64A1R5083	321-0398-00		RES,FXD,FILM:137K OHM,1%,0.125W,TC=TO	07716	CEAD13702F
A64A1R5084	315-0102-00		RES,FXD,FILM:1K OHM,5%,0.25W	80009	315-0102-00
A64A1R5086	315-0101-00		RES,FXD,FILM:100 OHM,5%,0.25W	80009	315-0101-00
A64A1R5096	315-0102-00		RES,FXD,FILM:1K OHM,5%,0.25W	80009	315-0102-00
A64A1R5097	315-0103-00		RES,FXD,FILM:10K OHM,5%,0.25W	80009	315-0103-00
A64A1R5099	315-0103-00		RES,FXD,FILM:10K OHM,5%,0.25W	80009	315-0103-00
A64A1R5102	315-0102-00		RES,FXD,FILM:1K OHM,5%,0.25W	80009	315-0102-00
A64A1R6017	321-0378-00		RES,FXD,FILM:84.5K OHM,1%,0.125W,TC=TO	07716	CEAD84501F
A64A1R6032	321-0424-00		RES,FXD,FILM:255K OHM,1%,0.125W,TC=TO	07716	CEAD25502F
A64A1R6034	315-0101-00		RES,FXD,FILM:100 OHM,5%,0.25W	80009	315-0101-00
A64A1R6071	321-0335-00		RES,FXD,FILM:30.1K OHM,1%,0.125W,TC=TO	80009	321-0335-00
A64A1R6072	321-0335-00		RES,FXD,FILM:30.1K OHM,1%,0.125W,TC=TO	80009	321-0335-00
A64A1R6073	321-0335-00		RES,FXD,FILM:30.1K OHM,1%,0.125W,TC=TO	80009	321-0335-00
A64A1R6081	321-0335-00		RES,FXD,FILM:30.1K OHM,1%,0.125W,TC=TO	80009	321-0335-00
A64A1R6082	315-0102-00		RES,FXD,FILM:1K OHM,5%,0.25W	80009	315-0102-00
A64A1R6084	315-0102-00		RES,FXD,FILM:1K OHM,5%,0.25W	80009	315-0102-00
A64A1R6086	321-0424-00		RES,FXD,FILM:255K OHM,1%,0.125W,TC=TO	07716	CEAD25502F
A64A1R6109	321-0378-00		RES,FXD,FILM:84.5K OHM,1%,0.125W,TC=TO	07716	CEAD84501F
A64A1R7021	315-0512-00		RES,FXD,FILM:5.1K OHM,5%,0.25W	80009	315-0512-00
A64A1R7022	315-0512-00		RES,FXD,FILM:5.1K OHM,5%,0.25W	80009	315-0512-00
A64A1R7023	315-0512-00		RES,FXD,FILM:5.1K OHM,5%,0.25W	80009	315-0512-00
A64A1R7031	315-0101-00		RES,FXD,FILM:100 OHM,5%,0.25W	80009	315-0101-00
A64A1R7032	321-0439-00		RES,FXD,FILM:365K OHM,1%,0.125W,TC=TO	07716	CEAD36502F
A64A1R7034	321-0338-00		RES,FXD,FILM:32.4K OHM,1%,0.125W,TC=TO	80009	321-0338-00
A64A1R7051	321-0335-00		RES,FXD,FILM:30.1K OHM,1%,0.125W,TC=TO	80009	321-0335-00
A64A1R7078	315-0100-00		RES,FXD,FILM:10 OHM,5%,0.25W	19701	5043CX10RR00J
A64A1R7079	315-0100-00		RES,FXD,FILM:10 OHM,5%,0.25W	19701	5043CX10RR00J
A64A1R7081	321-0335-00		RES,FXD,FILM:30.1K OHM,1%,0.125W,TC=TO	80009	321-0335-00
A64A1R8071	315-0104-00		RES,FXD,FILM:100K OHM,5%,0.25W	80009	315-0104-00
A64A1U2060	156-0742-02		IC,LINEAR:BIPOLAR,OP-AMP;DUPLICATE OF 156-0742-00,DO NOT USE;LM318N,DIP08.3	80009	156-0742-02
A64A1U2062	156-0742-02		IC,LINEAR:BIPOLAR,OP-AMP;DUPLICATE OF 156-0742-00,DO NOT USE;LM318N,DIP08.3	80009	156-0742-02
A64A1U6024	156-1226-00		IC,LINEAR:BIPOLAR,COMPARATOR;DUAL,OPEN COLLECTOR,8ONS;LM319N,DIP14.3	18324	LM319F
A64A1U6055	156-1211-00		IC,MISC:BIFET,ANALOG SWITCH;QUAD;LF13333,DI P16.3	80009	156-1211-00
A64A1U6065	156-0742-02		IC,LINEAR:BIPOLAR,OP-AMP;DUPLICATE OF 156-0742-00,DO NOT USE;LM318N,DIP08.3	80009	156-0742-02
A64A1U6073	156-0742-02		IC,LINEAR:BIPOLAR,OP-AMP;DUPLICATE OF 156-0742-00,DO NOT USE;LM318N,DIP08.3	80009	156-0742-02
A64A1U7055	156-1211-00		IC,MISC:BIFET,ANALOG SWITCH;QUAD;LF13333,DI P16.3	80009	156-1211-00
A64A1U7065	156-0742-02		IC,LINEAR:BIPOLAR,OP-AMP;DUPLICATE OF 156-0742-00,DO NOT USE;LM318N,DIP08.3	80009	156-0742-02

Replaceable Electrical Parts
494A/494AP Service Vol.2

Component No.	Tektronix Part No.	Serial/Assembly No. Effective Dscont	Name & Description	Mfr. Code	Mfr. Part No.
A64A1U7073	156-0158-00		IC, LINEAR: BIPOLAR, OP-AMP; DUAL; MC1458P1, DIPO 8.3	80009	156-0158-00
A64A1VR1035	152-0279-00		DIODE, ZENER: ; 5.1V, 5%, 0.4W; 1N751A, DO-7 OR 3 5, TR	80009	152-0279-00
A64A1VR3074	152-0279-00		DIODE, ZENER: ; 5.1V, 5%, 0.4W; 1N751A, DO-7 OR 3 5, TR	80009	152-0279-00
A66	672-0159-00		CIRCUIT BD ASSY: CRT READOUT	80009	672-0159-00
A66A1	670-7902-00		CIRCUIT BD ASSY: CRT READOUT	80009	670-7902-00
A66A1C1011	283-0047-00		CAP, FXD, CER DI: 270PF, 5%, 500V	80009	283-0047-00
A66A1C1014	283-0197-00		CAP, FXD, CER DI: 470PF, 5%, 50V	05397	C320C471J5G5CA
A66A1C1015	283-0197-00		CAP, FXD, CER DI: 470PF, 5%, 50V	05397	C320C471J5G5CA
A66A1C1018	283-0024-00		CAP, FXD, CER DI: 0.1UF, +80-20%, 50V	05397	C330C10YZ5U1CA
A66A1C1023	283-0024-00		CAP, FXD, CER DI: 0.1UF, +80-20%, 50V	05397	C330C10YZ5U1CA
A66A1C1031	283-0024-00		CAP, FXD, CER DI: 0.1UF, +80-20%, 50V	05397	C330C10YZ5U1CA
A66A1C1043	283-0024-00		CAP, FXD, CER DI: 0.1UF, +80-20%, 50V	05397	C330C10YZ5U1CA
A66A1C1057	283-0051-00		CAP, FXD, CER DI: 0.0033UF, 5%, 100V	80009	283-0051-00
A66A1C1058	283-0024-00		CAP, FXD, CER DI: 0.1UF, +80-20%, 50V	05397	C330C10YZ5U1CA
A66A1C2012	283-0204-00		CAP, FXD, CER DI: 0.01UF, 20%, 50V	51406	RPE110Z5U103M50V
A66A1C2013	283-0024-00		CAP, FXD, CER DI: 0.1UF, +80-20%, 50V	05397	C330C10YZ5U1CA
A66A1C2015	283-0024-00		CAP, FXD, CER DI: 0.1UF, +80-20%, 50V	05397	C330C10YZ5U1CA
A66A1C2016	283-0024-00		CAP, FXD, CER DI: 0.1UF, +80-20%, 50V	05397	C330C10YZ5U1CA
A66A1C2018	283-0024-00		CAP, FXD, CER DI: 0.1UF, +80-20%, 50V	05397	C330C10YZ5U1CA
A66A1C2020	283-0024-00		CAP, FXD, CER DI: 0.1UF, +80-20%, 50V	05397	C330C10YZ5U1CA
A66A1C2022	283-0024-00		CAP, FXD, CER DI: 0.1UF, +80-20%, 50V	05397	C330C10YZ5U1CA
A66A1C2026	283-0024-00		CAP, FXD, CER DI: 0.1UF, +80-20%, 50V	05397	C330C10YZ5U1CA
A66A1C2031	283-0024-00		CAP, FXD, CER DI: 0.1UF, +80-20%, 50V	05397	C330C10YZ5U1CA
A66A1C2038	283-0024-00		CAP, FXD, CER DI: 0.1UF, +80-20%, 50V	05397	C330C10YZ5U1CA
A66A1C2042	283-0024-00		CAP, FXD, CER DI: 0.1UF, +80-20%, 50V	05397	C330C10YZ5U1CA
A66A1C2056	283-0024-00		CAP, FXD, CER DI: 0.1UF, +80-20%, 50V	05397	C330C10YZ5U1CA
A66A1C3025	283-0024-00		CAP, FXD, CER DI: 0.1UF, +80-20%, 50V	05397	C330C10YZ5U1CA
A66A1C3026	283-0024-00		CAP, FXD, CER DI: 0.1UF, +80-20%, 50V	05397	C330C10YZ5U1CA
A66A1C3027	283-0204-00		CAP, FXD, CER DI: 0.01UF, 20%, 50V	51406	RPE110Z5U103M50V
A66A1C3028	283-0024-00		CAP, FXD, CER DI: 0.1UF, +80-20%, 50V	05397	C330C10YZ5U1CA
A66A1C3049	283-0024-00		CAP, FXD, CER DI: 0.1UF, +80-20%, 50V	05397	C330C10YZ5U1CA
A66A1C3056	283-0024-00		CAP, FXD, CER DI: 0.1UF, +80-20%, 50V	05397	C330C10YZ5U1CA
A66A1C3057	283-0024-00		CAP, FXD, CER DI: 0.1UF, +80-20%, 50V	05397	C330C10YZ5U1CA
A66A1CR1012	152-0322-00		DIODE, SIG: SCHTKY, ; 15V, 410MVF AT 1MA, 1.2PF; 5 082-2811, T&R	80009	152-0322-00
A66A1CR1013	152-0322-00		DIODE, SIG: SCHTKY, ; 15V, 410MVF AT 1MA, 1.2PF; 5 082-2811, T&R	80009	152-0322-00
A66A1L3055	108-0836-00		COIL, RF: FIXED, 14UH	80009	108-0836-00
A66A1L3056	108-0537-00		COIL, RF: FIXED, 200UH	80009	108-0537-00
A66A1L3059	108-0537-00		COIL, RF: FIXED, 200UH	80009	108-0537-00
A66A1Q2024	151-0190-00		TRANSISTOR, SIG: BIPOLAR, NPN; 40V, 200MA, 300MHZ ,AMPLIFIER; 2N3904, TO-92 EBC	80009	151-0190-00
A66A1Q3018	151-0190-00		TRANSISTOR, SIG: BIPOLAR, NPN; 40V, 200MA, 300MHZ ,AMPLIFIER; 2N3904, TO-92 EBC	80009	151-0190-00
A66A1R1014	315-0102-00		RES, FXD, FILM: 1K OHM, 5%, 0.25W	80009	315-0102-00
A66A1R1015	315-0103-00		RES, FXD, FILM: 10K OHM, 5%, 0.25W	80009	315-0103-00
A66A1R1016	321-0307-00		RES, FXD, FILM: 15.4K OHM, 1%, 0.125W, TC=TO	80009	321-0307-00
A66A1R1017	321-1313-08		RES, FXD, FILM: 18K OHM, 1%, 0.125W, TC=T2	07716	CEAC18001F
A66A1R1026	315-0472-00		RES, FXD, FILM: 4.7K OHM, 5%, 0.25W	80009	315-0472-00
A66A1R1033	315-0472-00		RES, FXD, FILM: 4.7K OHM, 5%, 0.25W	80009	315-0472-00
A66A1R1040	315-0103-00		RES, FXD, FILM: 10K OHM, 5%, 0.25W	80009	315-0103-00
A66A1R1042	315-0103-00		RES, FXD, FILM: 10K OHM, 5%, 0.25W	80009	315-0103-00
A66A1R1056	315-0102-00		RES, FXD, FILM: 1K OHM, 5%, 0.25W	80009	315-0102-00
A66A1R1057	321-0366-00		RES, FXD, FILM: 63.4K OHM, 1%, 0.125W, TC=TO	80009	321-0366-00
A66A1R1058	315-0102-00		RES, FXD, FILM: 1K OHM, 5%, 0.25W	80009	315-0102-00

Replaceable Electrical Parts
494A/494AP Service Vol.2

Component No.	Tektronix Part No.	Serial/Assembly No. Effective Dscont	Name & Description	Mfr. Code	Mfr. Part No.
A66A1R2012	321-0277-03		RES, FXD, FILM: 7.50K OHM, 0.25%, 0.125W, TC=T2	01121	ORDER BY DESCR
A66A1R2013	321-0277-03		RES, FXD, FILM: 7.50K OHM, 0.25%, 0.125W, TC=T2	01121	ORDER BY DESCR
A66A1R2016	321-0260-03		RES, FXD, FILM: 4.99K OHM, 0.25%, 0.125W, T=T2	01121	ORDER BY DESCR
A66A1R2017	321-0281-07		RES, FXD, FILM: 8.25K OHM, 0.1%, 0.125W, TC=T9	07716	CEAE82500B
A66A1R2018	321-0328-00		RES, FXD, FILM: 25.5K OHM, 1%, 0.125W, TC=T0	80009	321-0328-00
A66A1R2019	315-0472-00		RES, FXD, FILM: 4.7K OHM, 5%, 0.25W	80009	315-0472-00
A66A1R2021	315-0153-00		RES, FXD, FILM: 15K OHM, 5%, 0.25W	80009	315-0153-00
A66A1R2027	321-0242-00		RES, FXD, FILM: 3.24K OHM, 1%, 0.125W, TC=T0	80009	321-0242-00
A66A1R2028	321-0296-00		RES, FXD, FILM: 11.8K OHM, 1%, 0.125W, TC=T0	07716	CEAD11801F
A66A1R3014	321-0219-00		RES, FXD, FILM: 1.87K OHM, 1%, 0.125W, TC=T0	80009	321-0219-00
A66A1R3015	321-0301-00		RES, FXD, FILM: 13.3K OHM, 1%, 0.125W, TC=T0	07716	CEAD13301F
A66A1R3025	321-0307-00		RES, FXD, FILM: 15.4K OHM, 1%, 0.125W, TC=T0	80009	321-0307-00
A66A1R3026	321-0603-00		RES, FXD, FILM: 15K OHM, 0.25%, 0.125W, TC=T2	80009	321-0603-00
A66A1R3027	321-0303-00		RES, FXD, FILM: 14.0K OHM, 1%, 0.125W, TC=T0	07716	CEAD 14001F
A66A1R3028	321-1723-07		RES, FXD, FILM: 3.15K OHM, 0.1%, 0.125W, TC=T9	80009	321-1723-07
A66A1U1016	156-0733-00		IC, DIGITAL:	01295	SN74LS221N
A66A1U1020	156-0391-00		IC, DIGITAL: LSTTL, FLIP FLOP; HEX D W/CLR; 74LS174, DIP16.3, TUBE	80009	156-0391-00
A66A1U1025	156-0480-00		IC, DIGITAL: LSTTL, GATES; QUAD 2-INPUT AND; 74LS08, DIP14.3, TUBE	80009	156-0480-00
A66A1U1028	156-0385-00		IC, DIGITAL: LSTTL, GATES; HEX INV; 74LS04, DIP14.3, TUBE	80009	156-0385-00
A66A1U1033	156-0718-00		IC, DIGITAL: LSTTL, GATES; TRIPLE 3-INPUT NOR; 74LS27, DIP14.3, TUBE	80009	156-0718-00
A66A1U1037	156-0386-00		IC, DIGITAL: LSTTL, GATES; TRIPLE 3-INPUT NAND; 74LS10, DIP14.3, TUBE	80009	156-0386-00
A66A1U1041	156-1059-01		IC, DIGITAL: LSTTL, FLIP FLOP; DUAL J-K, W/SET & CLR; 74LS109, DIP16.3, TUBE	80009	156-1059-01
A66A1U1046	156-0530-00		IC, DIGITAL: LSTTL, MUX; QUAD 2-TO-1, DATA SELECTOR, NONINV; 74LS157, DIP16.3, TUBE	80009	156-0530-00
A66A1U1050	156-0798-00		IC, DIGITAL: LSTTL, MUX/ENCODER; DUAL 4-TO-1; 74LS153, DIP16.3, TUBE	80009	156-0798-00
A66A1U1055	156-0733-00		IC, DIGITAL:	01295	SN74LS221N
A66A1U2014	156-0844-00		IC, DIGITAL: LSTTL, COUNTER; SYNCH 4-BIT BINARY; 74LS161, DIP16.3, TUBE	80009	156-0844-00
A66A1U2018	156-0844-00		IC, DIGITAL: LSTTL, COUNTER; SYNCH 4-BIT BINARY; 74LS161, DIP16.3, TUBE	80009	156-0844-00
A66A1U2022	156-0844-00		IC, DIGITAL: LSTTL, COUNTER; SYNCH 4-BIT BINARY; 74LS161, DIP16.3, TUBE	80009	156-0844-00
A66A1U2026	156-0844-00		IC, DIGITAL: LSTTL, COUNTER; SYNCH 4-BIT BINARY; 74LS161, DIP16.3, TUBE	80009	156-0844-00
A66A1U2031	156-0469-00		IC, DIGITAL: LSTTL, DEMUX/DECODER; 3-TO-8 DECODER; 74LS138, DIP16.3, TUBE	80009	156-0469-00
A66A1U2035	156-0385-00		IC, DIGITAL: LSTTL, GATES; HEX INV; 74LS04, DIP14.3, TUBE	80009	156-0385-00
A66A1U2039	156-0386-00		IC, DIGITAL: LSTTL, GATES; TRIPLE 3-INPUT NAND; 74LS10, DIP14.3, TUBE	80009	156-0386-00
A66A1U2044	156-0479-00		IC, DIGITAL: LSTTL, GATES; QUAD 2-INPUT OR; 74LS32, DIP14.3, TUBE	80009	156-0479-00
A66A1U2048	156-1170-00		MICROCKT, DGTL: TTL, ROM, CHAR GEN	27014	DM86S64CAB/N
A66A1U2052	156-1614-00		IC, MEMORY: NMOS, SRAM; 1K X 4, 150NS; , DIP18.3, CERAMIC	80009	156-1614-00
A66A1U2057	156-1614-00		IC, MEMORY: NMOS, SRAM; 1K X 4, 150NS; , DIP18.3, CERAMIC	80009	156-1614-00
A66A1U3015	156-1255-00		IC, CONVERTER: BIPOLAR, D/A; 8 BIT, 85NS, CURRENT OUT, MULTIPLYING; DAC08BP, DIP16.3	80009	156-1255-00
A66A1U3021	156-1211-00		IC, MISC: BIFET, ANALOG SWITCH; QUAD; LF13333, DIP16.3	80009	156-1211-00

Replaceable Electrical Parts
494A/494AP Service Vol.2

Component No.	Tektronix Part No.	Serial/Assembly No. Effective	Discont	Name & Description	Mfr. Code	Mfr. Part No.
A66A1U3029	156-1589-00			IC, CONVERTER: BIPOLAR, D/A; 12 BIT, CURRENT OUT, MULTIPLYING; AM6012/DAC312, DIP20.3	80009	156-1589-00
A66A1U3034	156-0913-00			IC, DIGITAL: LSTTL, FLIP FLOP; OCTAL D-TYPE, ENABLE; 74LS377, DIP20.3, TUBE	80009	156-0913-00
A66A1U3038	156-0982-00			IC, DIGITAL: LSTTL, FLIP FLOP; OCTAL D, POS EDG E TRIG, 3-STATE; 74LS374, DIP20.3, TUBE	80009	156-0982-00
A66A1U3042	156-0956-00			IC, DIGITAL: LSTTL, BUFFER/DRIVER; OCTAL NONINV, 3-STATE; 74LS244, DIP20.3, TUBE	80009	156-0956-00
A66A1U3047	156-0956-00			IC, DIGITAL: LSTTL, BUFFER/DRIVER; OCTAL NONINV, 3-STATE; 74LS244, DIP20.3, TUBE	80009	156-0956-00
A66A1U3051	156-0469-00			IC, DIGITAL: LSTTL, DEMUX/DECODER; 3-TO-8 DECODER; 74LS138, DIP16.3, TUBE	80009	156-0469-00
A66A1VR1025	152-0326-00			DIODE, ZENER; ; 7.5V, 5%, 0.4W; 1N755A FMLY, DO-7 OR 35, TR	25088	DZ720925A
A66A1VR1029	152-0326-00			DIODE, ZENER; ; 7.5V, 5%, 0.4W; 1N755A FMLY, DO-7 OR 35, TR	25088	DZ720925A
A68	644-0645-00	B010100	B010181	VR MODULE ASSY::	80009	644-0645-00
A68	644-0645-02	B010182	B010389	VR MODULE ASSY:	80009	644-0645-02
A68	644-0645-03	B010390		VAR RESOLN MDL: 495/P	80009	644-0645-03
A68	644-0675-00	B010100	B010181	VR MODULAR ASSY:	80009	644-0675-00
A68	644-0675-01	B010182	B010389	VR MODULE ASSY:	80009	644-0675-01
A68	644-0675-02	B010390		VAR RESOLN MDL: 494/AP (OPTION 07 ONLY)	80009	644-0675-02
A68FL6015	119-1676-00			FILTER, BANDPASS: XTAL, 10MHZ CTR FREQ, 200HZ BW, TEMP COMP (MATCHED SET W/FL690 ON CHASSIS)	59492	001-37440
A68U3041	156-0277-00			IC, LINEAR: BIPOLAR, VOLTAGE REGULATOR; POSITIVE, 5.0V, 1.0A, 4%; MC7805CT, TO-220	80009	156-0277-00
A68W696	175-2417-00			CABLE ASSY, RF: 50 OHM COAX, 27.0 L	TK2469	175-2417-00
A68Y2036	119-0968-00			FILTER, BANDPASS: XTAL, 6 POLE ML (MATCHED SET W/A68Y6050 & A68Y3046)	75378	965-0159
A68Y2043	119-0969-00			FILTER, BANDPASS: XTAL, 4 POLE ML (MATCHED SET W/A68Y5040)	75378	965-0160
A68Y3046	119-0968-00			FILTER, BANDPASS: XTAL, 6 POLE ML (MATCHED SET W/A68Y6050 & A68Y2036)	75378	965-0159
A68Y5040	119-0969-00			FILTER, BANDPASS: XTAL, 4 POLE ML (MATCHED SET W/A68Y2043)	75378	965-0160
A68Y6050	119-0968-00			FILTER, BANDPASS: XTAL, 6 POLE ML (MATCHED SET W/A68Y2036 & A68Y3046)	75378	965-0159
A68A1	670-5528-03			CIRCUIT BD ASSY: #1VR MOTHER	80009	670-5528-03
A68A1C1066	283-0111-00			CAP, FXD, CER DI: 0.1UF, 20%, 50V	80009	283-0111-00
A68A1C1067	283-0111-00			CAP, FXD, CER DI: 0.1UF, 20%, 50V	80009	283-0111-00
A68A1C1068	283-0111-00			CAP, FXD, CER DI: 0.1UF, 20%, 50V	80009	283-0111-00
A68A1C1069	283-0111-00			CAP, FXD, CER DI: 0.1UF, 20%, 50V	80009	283-0111-00
A68A1C1075	283-0111-00			CAP, FXD, CER DI: 0.1UF, 20%, 50V	80009	283-0111-00
A68A1C1082	283-0111-00			CAP, FXD, CER DI: 0.1UF, 20%, 50V	80009	283-0111-00
A68A1C1083	283-0111-00			CAP, FXD, CER DI: 0.1UF, 20%, 50V	80009	283-0111-00
A68A1C1084	283-0111-00			CAP, FXD, CER DI: 0.1UF, 20%, 50V	80009	283-0111-00
A68A1C1085	283-0111-00			CAP, FXD, CER DI: 0.1UF, 20%, 50V	80009	283-0111-00
A68A1C2076	283-0111-00			CAP, FXD, CER DI: 0.1UF, 20%, 50V	80009	283-0111-00
A68A1C2086	283-0111-00			CAP, FXD, CER DI: 0.1UF, 20%, 50V	80009	283-0111-00
A68A1C2088	283-0111-00			CAP, FXD, CER DI: 0.1UF, 20%, 50V	80009	283-0111-00
A68A1C3019	283-0111-00			CAP, FXD, CER DI: 0.1UF, 20%, 50V	80009	283-0111-00
A68A1C3026	283-0111-00			CAP, FXD, CER DI: 0.1UF, 20%, 50V	80009	283-0111-00
A68A1C3028	283-0111-00			CAP, FXD, CER DI: 0.1UF, 20%, 50V	80009	283-0111-00
A68A1C3029	283-0111-00			CAP, FXD, CER DI: 0.1UF, 20%, 50V	80009	283-0111-00
A68A1C3035	283-0111-00			CAP, FXD, CER DI: 0.1UF, 20%, 50V	80009	283-0111-00
A68A1C3043	283-0111-00			CAP, FXD, CER DI: 0.1UF, 20%, 50V	80009	283-0111-00
A68A1C3048	283-0111-00			CAP, FXD, CER DI: 0.1UF, 20%, 50V	80009	283-0111-00

Replaceable Electrical Parts
494A/494AP Service Vol.2

Component No.	Tektronix		Serial/Assembly No.		Name & Description	Mfr. Code	Mfr. Part No.
	Part No.		Effective	Discont			
A68A1C3049	283-0111-00				CAP,FXD,CER DI:0.1UF,20%,50V	80009	283-0111-00
A68A1C3062	283-0204-00				CAP,FXD,CER DI:0.01UF,20%,50V	51406	RPE110Z5U103M50V
A68A1C3066	283-0204-00				CAP,FXD,CER DI:0.01UF,20%,50V	51406	RPE110Z5U103M50V
A68A1C3077	283-0204-00				CAP,FXD,CER DI:0.01UF,20%,50V	51406	RPE110Z5U103M50V
A68A1L3065	108-0395-00				COIL,RF:FIXED,64UH	80009	108-0395-00
A68A1L3066	108-0395-00				COIL,RF:FIXED,64UH	80009	108-0395-00
A68A1P3072	131-2167-00				CONN,BOX:	80009	131-2167-00
A68A1R1065	315-0100-00				RES,FXD,FILM:10 OHM,5%,0.25W	19701	5043CX10RR00J
A68A1R1066	315-0100-00				RES,FXD,FILM:10 OHM,5%,0.25W	19701	5043CX10RR00J
A68A1R1067	315-0100-00				RES,FXD,FILM:10 OHM,5%,0.25W	19701	5043CX10RR00J
A68A1R1068	315-0100-00				RES,FXD,FILM:10 OHM,5%,0.25W	19701	5043CX10RR00J
A68A1R1075	315-0100-00				RES,FXD,FILM:10 OHM,5%,0.25W	19701	5043CX10RR00J
A68A1R1082	315-0100-00				RES,FXD,FILM:10 OHM,5%,0.25W	19701	5043CX10RR00J
A68A1R1083	315-0100-00				RES,FXD,FILM:10 OHM,5%,0.25W	19701	5043CX10RR00J
A68A1R1084	315-0100-00				RES,FXD,FILM:10 OHM,5%,0.25W	19701	5043CX10RR00J
A68A1R1085	315-0100-00				RES,FXD,FILM:10 OHM,5%,0.25W	19701	5043CX10RR00J
A68A1R2076	315-0100-00				RES,FXD,FILM:10 OHM,5%,0.25W	19701	5043CX10RR00J
A68A1R2086	315-0100-00				RES,FXD,FILM:10 OHM,5%,0.25W	19701	5043CX10RR00J
A68A1R2088	315-0100-00				RES,FXD,FILM:10 OHM,5%,0.25W	19701	5043CX10RR00J
A68A1R3019	315-0270-00				RES,FXD,FILM:27 OHM,5%,0.25W	80009	315-0270-00
A68A1R3026	315-0100-00				RES,FXD,FILM:10 OHM,5%,0.25W	19701	5043CX10RR00J
A68A1R3028	315-0100-00				RES,FXD,FILM:10 OHM,5%,0.25W	19701	5043CX10RR00J
A68A1R3029	315-0100-00				RES,FXD,FILM:10 OHM,5%,0.25W	19701	5043CX10RR00J
A68A1R3035	315-0100-00				RES,FXD,FILM:10 OHM,5%,0.25W	19701	5043CX10RR00J
A68A1R3043	315-0100-00				RES,FXD,FILM:10 OHM,5%,0.25W	19701	5043CX10RR00J
A68A1R3048	307-0106-00				RES,FXD,CMPSN:4.7 OHM,5%,0.25W	01121	CB4765
A68A1R3049	315-0100-00				RES,FXD,FILM:10 OHM,5%,0.25W	19701	5043CX10RR00J
A68A1R3081	315-0101-00				RES,FXD,FILM:100 OHM,5%,0.25W	80009	315-0101-00
A68A2	670-5536-04	B010100	B010389		CIRCUIT BD ASSY:#2 V.R. MOTHER	80009	670-5536-04
A68A2	670-5536-05	B010390			CIRCUIT BD ASSY:#2 V.R. MOTHER	80009	670-5536-05
A68A2C2011	283-0111-00				CAP,FXD,CER DI:0.1UF,20%,50V	80009	283-0111-00
A68A2C2015	283-0111-00				CAP,FXD,CER DI:0.1UF,20%,50V	80009	283-0111-00
A68A2C2018	283-0111-00				CAP,FXD,CER DI:0.1UF,20%,50V	80009	283-0111-00
A68A2C2023	283-0204-00				CAP,FXD,CER DI:0.01UF,20%,50V	51406	RPE110Z5U103M50V
A68A2C2033	283-0204-00				CAP,FXD,CER DI:0.01UF,20%,50V	51406	RPE110Z5U103M50V
A68A2C3019	283-0111-00				CAP,FXD,CER DI:0.1UF,20%,50V	80009	283-0111-00
A68A2C3027	283-0111-00				CAP,FXD,CER DI:0.1UF,20%,50V	80009	283-0111-00
A68A2C3041	290-0340-00				CAP,FXD,ELCTLT:10UF,10%,50V	80009	290-0340-00
A68A2C3042	283-0111-00				CAP,FXD,CER DI:0.1UF,20%,50V	80009	283-0111-00
A68A2C3043	283-0330-00	B010390			CAP,FXD,CER DI:100PF,5%,50V	80009	283-0330-00
A68A2C4027	283-0111-00				CAP,FXD,CER DI:0.1UF,20%,50V	80009	283-0111-00
A68A2C4035	283-0204-00				CAP,FXD,CER DI:0.01UF,20%,50V	51406	RPE110Z5U103M50V
A68A2C4037	283-0204-00				CAP,FXD,CER DI:0.01UF,20%,50V	51406	RPE110Z5U103M50V
A68A2C4038	283-0204-00				CAP,FXD,CER DI:0.01UF,20%,50V	51406	RPE110Z5U103M50V
A68A2C4039	283-0111-00				CAP,FXD,CER DI:0.1UF,20%,50V	80009	283-0111-00
A68A2CR3020	152-0141-02				DIODE,SIG:,ULTRA FAST;40V,150MA,4NS,2PF;1N4152,DO-35,T&R	80009	152-0141-02
A68A2CR3021	152-0141-02				DIODE,SIG:,ULTRA FAST;40V,150MA,4NS,2PF;1N4152,DO-35,T&R	80009	152-0141-02
A68A2CR3022	152-0141-02				DIODE,SIG:,ULTRA FAST;40V,150MA,4NS,2PF;1N4152,DO-35,T&R	80009	152-0141-02
A68A2CR3023	152-0141-02				DIODE,SIG:,ULTRA FAST;40V,150MA,4NS,2PF;1N4152,DO-35,T&R	80009	152-0141-02
A68A2CR3024	152-0141-02				DIODE,SIG:,ULTRA FAST;40V,150MA,4NS,2PF;1N4152,DO-35,T&R	80009	152-0141-02
A68A2CR3025	152-0141-02				DIODE,SIG:,ULTRA FAST;40V,150MA,4NS,2PF;1N4152,DO-35,T&R	80009	152-0141-02

Replaceable Electrical Parts
494A/494AP Service Vol.2

Component No.	Tektronix		Serial/Assembly No.		Name & Description	Mfr. Code	Mfr. Part No.
	Part No.	Effective	Discnt				
A68A2CR3026	152-0141-02				DIODE,SIG:,ULTRA FAST;40V,150MA,4NS,2PF;1N4152,DO-35,T&R	80009	152-0141-02
A68A2CR3027	152-0141-02				DIODE,SIG:,ULTRA FAST;40V,150MA,4NS,2PF;1N4152,DO-35,T&R	80009	152-0141-02
A68A2CR3031	152-0141-02				DIODE,SIG:,ULTRA FAST;40V,150MA,4NS,2PF;1N4152,DO-35,T&R	80009	152-0141-02
A68A2CR3033	152-0141-02				DIODE,SIG:,ULTRA FAST;40V,150MA,4NS,2PF;1N4152,DO-35,T&R	80009	152-0141-02
A68A2CR3034	152-0141-02				DIODE,SIG:,ULTRA FAST;40V,150MA,4NS,2PF;1N4152,DO-35,T&R	80009	152-0141-02
A68A2CR4029	152-0141-02				DIODE,SIG:,ULTRA FAST;40V,150MA,4NS,2PF;1N4152,DO-35,T&R	80009	152-0141-02
A68A2L4025	108-0395-00				COIL,RF:FIXED,64UH	80009	108-0395-00
A68A2L4031	108-0395-00				COIL,RF:FIXED,64UH	80009	108-0395-00
A68A2Q3035	151-0302-00				TRANSISTOR,SIG:BIPOLAR,NPN;40V,800MA,300MHZ,AMPLIFIER;2N2222A,TO-18	80009	151-0302-00
A68A2Q3036	151-0136-00				TRANSISTOR,SIG:BIPOLAR,NPN;40V,700MA,100MHZ,AMPLIFIER;2N3053,TO-39	80009	151-0136-00
A68A2Q4035	151-0302-00				TRANSISTOR,SIG:BIPOLAR,NPN;40V,800MA,300MHZ,AMPLIFIER;2N2222A,TO-18	80009	151-0302-00
A68A2Q4037	151-0302-00				TRANSISTOR,SIG:BIPOLAR,NPN;40V,800MA,300MHZ,AMPLIFIER;2N2222A,TO-18	80009	151-0302-00
A68A2R2014	315-0102-00				RES,FXD,FILM:1K OHM,5%,0.25W	80009	315-0102-00
A68A2R2026	315-0470-00				RES,FXD,FILM:47 OHM,5%,0.25W	80009	315-0470-00
A68A2R2031	311-0978-00				RES,VAR,NONWV:TRMR,250 OHM,0.5W	80009	311-0978-00
A68A2R2033	321-0756-00				RES,FXD,FILM:50K OHM,1%,0.125W,TC=TO	01121	
A68A2R2035	321-0289-00				RES,FXD,FILM:10.0K OHM,1%,0.125W,TC=TO	57668	FXE10K0
A68A2R2038	321-0289-00				RES,FXD,FILM:10.0K OHM,1%,0.125W,TC=TO	57668	FXE10K0
A68A2R3014	315-0102-00				RES,FXD,FILM:1K OHM,5%,0.25W	80009	315-0102-00
A68A2R3015	315-0102-00				RES,FXD,FILM:1K OHM,5%,0.25W	80009	315-0102-00
A68A2R3019	311-0978-00				RES,VAR,NONWV:TRMR,250 OHM,0.5W	80009	311-0978-00
A68A2R3020	321-0298-00				RES,FXD,FILM:12.4K OHM,1%,0.125W,TC=TO	07716	CEAD12401F
A68A2R3021	321-0298-00				RES,FXD,FILM:12.4K OHM,1%,0.125W,TC=TO	07716	CEAD12401F
A68A2R3022	311-0978-00				RES,VAR,NONWV:TRMR,250 OHM,0.5W	80009	311-0978-00
A68A2R3023	321-0298-00				RES,FXD,FILM:12.4K OHM,1%,0.125W,TC=TO	07716	CEAD12401F
A68A2R3024	311-0978-00				RES,VAR,NONWV:TRMR,250 OHM,0.5W	80009	311-0978-00
A68A2R3025	321-0298-00				RES,FXD,FILM:12.4K OHM,1%,0.125W,TC=TO	07716	CEAD12401F
A68A2R3026	311-0978-00				RES,VAR,NONWV:TRMR,250 OHM,0.5W	80009	311-0978-00
A68A2R3027	321-0298-00				RES,FXD,FILM:12.4K OHM,1%,0.125W,TC=TO	07716	CEAD12401F
A68A2R3028	311-0978-00				RES,VAR,NONWV:TRMR,250 OHM,0.5W	80009	311-0978-00
A68A2R3029	311-0978-00				RES,VAR,NONWV:TRMR,250 OHM,0.5W	80009	311-0978-00
A68A2R3030	311-0978-00				RES,VAR,NONWV:TRMR,250 OHM,0.5W	80009	311-0978-00
A68A2R3031	321-0298-00				RES,FXD,FILM:12.4K OHM,1%,0.125W,TC=TO	07716	CEAD12401F
A68A2R3032	311-0978-00				RES,VAR,NONWV:TRMR,250 OHM,0.5W	80009	311-0978-00
A68A2R3033	321-0298-00				RES,FXD,FILM:12.4K OHM,1%,0.125W,TC=TO	07716	CEAD12401F
A68A2R3034	311-0978-00				RES,VAR,NONWV:TRMR,250 OHM,0.5W	80009	311-0978-00
A68A2R3035	315-0103-00				RES,FXD,FILM:10K OHM,5%,0.25W	80009	315-0103-00
A68A2R3036	321-0298-00				RES,FXD,FILM:12.4K OHM,1%,0.125W,TC=TO	07716	CEAD12401F
A68A2R3037	315-0222-00				RES,FXD,FILM:2.2K OHM,5%,0.25W	80009	315-0222-00
A68A2R3038	321-0239-00				RES,FXD,FILM:3.01K OHM,1%,0.125W,TC=TO	80009	321-0239-00
A68A2R3039	321-0260-00				RES,FXD,FILM:4.99K OHM,1%,0.125W,TC=TO	19701	5033ED4K990F
A68A2R3041	321-0289-00				RES,FXD,FILM:10.0K OHM,1%,0.125W,TC=TO	57668	FXE10K0
A68A2R3042	321-0289-00				RES,FXD,FILM:10.0K OHM,1%,0.125W,TC=TO	57668	FXE10K0
A68A2R3043	315-0103-00				RES,FXD,FILM:10K OHM,5%,0.25W	80009	315-0103-00
A68A2R3044	315-0103-00				RES,FXD,FILM:10K OHM,5%,0.25W	80009	315-0103-00
A68A2R3045	315-0222-00				RES,FXD,FILM:2.2K OHM,5%,0.25W	80009	315-0222-00
A68A2R4026	321-0298-00				RES,FXD,FILM:12.4K OHM,1%,0.125W,TC=TO	07716	CEAD12401F
A68A2R4029	315-0222-00				RES,FXD,FILM:2.2K OHM,5%,0.25W	80009	315-0222-00

Replaceable Electrical Parts
494A/494AP Service Vol.2

Component No.	Tektronix		Name & Description	Mfr. Code	Mfr. Part No.
	Part No.	Serial/Assembly No. Effective Dscmt			
A68A2R4031	315-0103-00		RES,FXD,FILM:10K OHM,5%,0.25W	80009	315-0103-00
A68A2R4039	315-0100-00		RES,FXD,FILM:10 OHM,5%,0.25W	19701	5043CX10RR00J
A68A2U3010	156-0913-00		IC,DIGITAL:LSTTL,FLIP FLOP;OCTAL D-TYPE, EN ABLE;74LS377,DIP20.3,TUBE	80009	156-0913-00
A68A2U3017	156-0913-00		IC,DIGITAL:LSTTL,FLIP FLOP;OCTAL D-TYPE, EN ABLE;74LS377,DIP20.3,TUBE	80009	156-0913-00
A68A2U3023	156-1235-00		IC,DIGITAL:LSTTL,DEMUX/DECODER;BCD-TO-DECIMAL DECODER/DRIVER;74LS145,DIP16.3,TUBE	80009	156-1235-00
A68A2U3038	156-0158-00		IC,LINERAR:BIPOLAR,OP-AMP;DUAL;MC1458P1,DIP08.3	80009	156-0158-00
A68A2U4022	156-0469-00		IC,DIGITAL:LSTTL,DEMUX/DECODER;3-TO-8 DECODER;74LS138,DIP16.3,TUBE	80009	156-0469-00
A68A3	670-9843-00		CIRCUIT BD ASSY:VR INPUT	80009	670-9843-00
A68A3C1016	283-0111-00		CAP,FXD,CER DI:0.1UF,20%,50V	80009	283-0111-00
A68A3C1019	283-0111-00		CAP,FXD,CER DI:0.1UF,20%,50V	80009	283-0111-00
A68A3C1022	283-0111-00		CAP,FXD,CER DI:0.1UF,20%,50V	80009	283-0111-00
A68A3C1025	283-0111-00		CAP,FXD,CER DI:0.1UF,20%,50V	80009	283-0111-00
A68A3C1026	281-0167-00		CAP,VAR,CER DI:9-45PF,200V	33095	53-717-001 D9-45
A68A3C1031	283-0869-00		CAP,FXD,CER DI:68PF,NPO,100V,1%	80009	283-0869-00
A68A3C1032	281-0799-00		CAP,FXD,CER DI:62PF,2%,100V	80009	281-0799-00
A68A3C1033	281-0167-00		CAP,VAR,CER DI:9-45PF,200V	33095	53-717-001 D9-45
A68A3C1035	281-0577-00		CAP,FXD,CER DI:14PF,5%,500V	80009	281-0577-00
A68A3C1036	281-0799-00		CAP,FXD,CER DI:62PF,2%,100V	80009	281-0799-00
A68A3C1037	283-0869-00		CAP,FXD,CER DI:68PF,NPO,100V,1%	80009	283-0869-00
A68A3L1018	108-0395-00		COIL,RF:FIXED,64UH	80009	108-0395-00
A68A3L1027	108-0701-00		COIL,RF:FIXED,1.45UH	80009	108-0701-00
A68A3L1033	108-0701-00		COIL,RF:FIXED,1.45UH	80009	108-0701-00
A68A3Q1023	151-0650-00		TRANSISTOR,SIG:BIPOLAR,NPN;25V,300MA,1.4GHZ ,AMPLIFIER;NE74114/2SC1252,TO-39	50545	2SC1252
A68A3R1014	321-0114-00		RES,FXD,FILM:150 OHM,1%,0.125 W,TC=TO	80009	321-0114-00
A68A3R1015	321-0114-00		RES,FXD,FILM:150 OHM,1%,0.125 W,TC=TO	80009	321-0114-00
A68A3R1016	321-0054-00		RES,FXD,FILM:35.7 OHM,0.5%,0.125W,TC=TO MI	80009	321-0054-00
A68A3R1022	315-0270-00		RES,FXD,FILM:27 OHM,5%,0.25W	80009	315-0270-00
A68A3R1023	307-0113-00		RES,FXD,CMPNSN:5.1 OHM,5%,0.25W	01121	CB5165
A68A3R1024	315-0911-00		RES,FXD,FILM:910 OHM,5%,0.25W	80009	315-0911-00
A68A3R1025	315-0102-00		RES,FXD,FILM:1K OHM,5%,0.25W	80009	315-0102-00
A68A3R1026	315-0511-00		RES,FXD,FILM:510 OHM,5%,0.25W	80009	315-0511-00
A68A3T1019	120-0459-00		XFMR,TOROID:	80009	120-0459-00
A68A4	670-9531-00		CIRCUIT BD ASSY:1ST FILTER SELECT	80009	670-9531-00
A68A4	670-9951-00		CIRCUIT BD ASSY:1ST FILTER SELECT (OPTION 07 ONLY)	80009	670-9951-00
A68A4C0114	283-5003-00		CAP,FXD,CER DI:0.01UF,10%,50V	80009	283-5003-00
A68A4C1010	283-5003-00		CAP,FXD,CER DI:0.01UF,10%,50V	80009	283-5003-00
A68A4C1011	283-5003-00		CAP,FXD,CER DI:0.01UF,10%,50V	80009	283-5003-00
A68A4C1012	283-5003-00		CAP,FXD,CER DI:0.01UF,10%,50V	80009	283-5003-00
A68A4C1016	283-5003-00		CAP,FXD,CER DI:0.01UF,10%,50V	80009	283-5003-00
A68A4C1018	283-5003-00		CAP,FXD,CER DI:0.01UF,10%,50V	80009	283-5003-00
A68A4C1019	283-5003-00		CAP,FXD,CER DI:0.01UF,10%,50V	80009	283-5003-00
A68A4C1020	283-5003-00		CAP,FXD,CER DI:0.01UF,10%,50V	80009	283-5003-00
A68A4C1022	283-5003-00		CAP,FXD,CER DI:0.01UF,10%,50V	80009	283-5003-00
A68A4C1030	283-0213-00		CAP,FXD,CER DI:300PF,5%,100V	80009	283-0213-00
A68A4C1032	281-0765-00		CAP,FXD,CER DI:100PF,5%,100V	04222	SA102A101JAA
A68A4C1034	281-0205-00		CAP,VAR,PLASTIC:5.5-65 PF,100V	TK1727	2222-808-32659
A68A4C1040	281-0898-00		CAP,FXD,CER DI:7.5PF,+/-0.5PF,500V	04222	MA107A7R5DAA
A68A4C1044	281-0205-00		CAP,VAR,PLASTIC:5.5-65 PF,100V	TK1727	2222-808-32659
A68A4C1046	281-0205-00		CAP,VAR,PLASTIC:5.5-65 PF,100V	TK1727	2222-808-32659
A68A4C1050	281-0764-00		CAP,FXD,CER DI:82PF,5%,100V	04222	SA102A82QJAA
A68A4C1052	283-0159-00		CAP,FXD,CER DI:18PF,5%,50V	05397	C315C180J565CA

Replaceable Electrical Parts
494A/494AP Service Vol.2

Component No.	Tektronix Part No.	Serial/Assembly No. Effective Discnt	Name & Description	Mfr. Code	Mfr. Part No.
A68A4C1054	283-0359-00		CAP, FXD, CER DI: 1000PF, 10%, 200V	04222	SR212A102KAA
A68A4C1056	283-0359-00		CAP, FXD, CER DI: 1000PF, 10%, 200V	04222	SR212A102KAA
A68A4C1057	283-5003-00		CAP, FXD, CER DI: 0.01UF, 10%, 50V	80009	283-5003-00
A68A4C1058	281-0765-00		CAP, FXD, CER DI: 100PF, 5%, 100V	04222	SA102A101JAA
A68A4C1059	283-5003-00		CAP, FXD, CER DI: 0.01UF, 10%, 50V	80009	283-5003-00
A68A4C1060	283-0213-00		CAP, FXD, CER DI: 300PF, 5%, 100V	80009	283-0213-00
A68A4C1067	283-5003-00		CAP, FXD, CER DI: 0.01UF, 10%, 50V	80009	283-5003-00
A68A4C2010	283-5003-00		CAP, FXD, CER DI: 0.01UF, 10%, 50V	80009	283-5003-00
A68A4C2012	283-5003-00		CAP, FXD, CER DI: 0.01UF, 10%, 50V	80009	283-5003-00
A68A4C2014	283-5003-00		CAP, FXD, CER DI: 0.01UF, 10%, 50V	80009	283-5003-00
A68A4C2016	283-5003-00		CAP, FXD, CER DI: 0.01UF, 10%, 50V	80009	283-5003-00
A68A4C2018	283-5003-00		CAP, FXD, CER DI: 0.01UF, 10%, 50V	80009	283-5003-00
A68A4C2020	283-5003-00		CAP, FXD, CER DI: 0.01UF, 10%, 50V	80009	283-5003-00
A68A4C2030	281-0221-00		CAP, VAR, CER DI: 2-10PF, 100V	80009	281-0221-00
A68A4C2050	283-5003-00		CAP, FXD, CER DI: 0.01UF, 10%, 50V	80009	283-5003-00
A68A4C2052	283-5003-00		CAP, FXD, CER DI: 0.01UF, 10%, 50V	80009	283-5003-00
A68A4C2053	283-5003-00		CAP, FXD, CER DI: 0.01UF, 10%, 50V	80009	283-5003-00
A68A4C2055	283-5003-00		CAP, FXD, CER DI: 0.01UF, 10%, 50V	80009	283-5003-00
A68A4C2056	283-5003-00		CAP, FXD, CER DI: 0.01UF, 10%, 50V	80009	283-5003-00
A68A4C2059	283-5003-00		CAP, FXD, CER DI: 0.01UF, 10%, 50V	80009	283-5003-00
A68A4C3010	283-5003-00		CAP, FXD, CER DI: 0.01UF, 10%, 50V	80009	283-5003-00
A68A4C3012	283-5003-00		CAP, FXD, CER DI: 0.01UF, 10%, 50V	80009	283-5003-00
A68A4C3013	281-0764-00		CAP, FXD, CER DI: 82PF, 5%, 100V	04222	SA102A820JAA
A68A4C3016	283-0359-00		CAP, FXD, CER DI: 1000PF, 10%, 200V	04222	SR212A102KAA
A68A4C3016	283-0398-00		CAP, FXD, CER DI: 680PF, 2%, 100V (OPTION 07 ONLY)	04222	SR201A681GAA
A68A4C3018	283-5003-00		CAP, FXD, CER DI: 0.01UF, 10%, 50V	80009	283-5003-00
A68A4C3019	283-5003-00		CAP, FXD, CER DI: 0.01UF, 10%, 50V	80009	283-5003-00
A68A4C3029	283-0838-00		CAP, FXD, CER DI: 18PF, 5%, 50V	80009	283-0838-00
A68A4C3030	281-0153-00		CAP, VAR, CER DI: 1.7-10PF, 250V	80009	281-0153-00
A68A4C3031	281-0764-00		CAP, FXD, CER DI: 82PF, 5%, 100V	04222	SA102A820JAA
A68A4C3032	281-0810-00		CAP, FXD, CER DI: 5.6PF, +/-0.5PF, 100V	04222	SA101A5R6DAA
A68A4C3032	283-0168-00		CAP, FXD, CER DI: 12PF, 5%, 100V (OPTION 07 ONLY)	04222	SR151A120JAA
A68A4C3033	281-0810-00		CAP, FXD, CER DI: 5.6PF, +/-0.5PF, 100V	04222	SA101A5R6DAA
A68A4C3034	283-0159-00		CAP, FXD, CER DI: 18PF, 5%, 50V	05397	C315C180J5G5CA
A68A4C3035	281-0811-00		CAP, FXD, CER DI: 10PF, 10%, 100V	04222	SA102A100KAA
A68A4C3037	281-0810-00		CAP, FXD, CER DI: 5.6PF, +/-0.5PF, 100V	04222	SA101A5R6DAA
A68A4C3039	281-0153-00		CAP, VAR, AIR DI: 1.7-10PF, 250V	80009	281-0153-00
A68A4C3040	281-0810-00		CAP, FXD, CER DI: 5.6PF, +/-0.5PF, 100V	04222	SA101A5R6DAA
A68A4C3040	283-0168-00		CAP, FXD, CER DI: 12PF, 5%, 100V (OPTION 07 ONLY)	04222	SR151A120JAA
A68A4C3041	281-0810-00		CAP, FXD, CER DI: 5.6PF, +/-0.5PF, 100V	04222	SA101A5R6DAA
A68A4C3042	281-0811-00		CAP, FXD, CER DI: 10PF, 10%, 100V	04222	SA102A100KAA
A68A4C3045	281-0153-00		CAP, VAR, AIR DI: 1.7-10PF, 250V	80009	281-0153-00
A68A4C3046	283-0838-00		CAP, FXD, CER DI: 18PF, 5%, 50V	80009	283-0838-00
A68A4C3047	283-0159-00		CAP, FXD, CER DI: 18PF, 5%, 50V	05397	C315C180J5G5CA
A68A4C3049	281-0764-00		CAP, FXD, CER DI: 82PF, 5%, 100V	04222	SA102A820JAA
A68A4C3050	283-5003-00		CAP, FXD, CER DI: 0.01UF, 10%, 50V	80009	283-5003-00
A68A4C3052	283-5003-00		CAP, FXD, CER DI: 0.01UF, 10%, 50V	80009	283-5003-00
A68A4C3053	281-0764-00		CAP, FXD, CER DI: 82PF, 5%, 100V	04222	SA102A820JAA
A68A4C3054	283-0359-00		CAP, FXD, CER DI: 1000PF, 10%, 200V	04222	SR212A102KAA
A68A4C3054	283-0398-00		CAP, FXD, CER DI: 680PF, 2%, 100V (OPTION 07 ONLY)	04222	SR201A681GAA
A68A4C3058	283-5003-00		CAP, FXD, CER DI: 0.01UF, 10%, 50V	80009	283-5003-00
A68A4C3060	283-5003-00		CAP, FXD, CER DI: 0.01UF, 10%, 50V	80009	283-5003-00
A68A4C3064	283-5003-00		CAP, FXD, CER DI: 0.01UF, 10%, 50V	80009	283-5003-00
A68A4C4010	283-5003-00		CAP, FXD, CER DI: 0.01UF, 10%, 50V	80009	283-5003-00
A68A4C4030	283-5003-00		CAP, FXD, CER DI: 0.01UF, 10%, 50V	80009	283-5003-00

Replaceable Electrical Parts
494A/494AP Service Vol.2

Component No.	Tektronix Part No.	Serial/Assembly No. Effective Dscnt	Name & Description	Mfr. Code	Mfr. Part No.
A68A4C4031	283-5003-00		CAP,FXD,CER DI:0.01UF,10%,50V	80009	283-5003-00
A68A4C4032	283-5003-00		CAP,FXD,CER DI:0.01UF,10%,50V	80009	283-5003-00
A68A4C4033	283-5003-00		CAP,FXD,CER DI:0.01UF,10%,50V	80009	283-5003-00
A68A4C4034	283-5003-00		CAP,FXD,CER DI:0.01UF,10%,50V	80009	283-5003-00
A68A4C4036	283-5003-00		CAP,FXD,CER DI:0.01UF,10%,50V	80009	283-5003-00
A68A4C4037	283-5003-00		CAP,FXD,CER DI:0.01UF,10%,50V	80009	283-5003-00
A68A4C4039	283-5004-00		CAP,FXD,CER DI:0.1UF,10%,25V	80009	283-5004-00
A68A4C4050	283-5003-00		CAP,FXD,CER DI:0.01UF,10%,50V	80009	283-5003-00
A68A4C4051	283-5003-00		CAP,FXD,CER DI:0.01UF,10%,50V	80009	283-5003-00
A68A4C4053	283-5003-00		CAP,FXD,CER DI:0.01UF,10%,50V	80009	283-5003-00
A68A4C4055	283-5003-00		CAP,FXD,CER DI:0.01UF,10%,50V	80009	283-5003-00
A68A4C4057	283-5003-00		CAP,FXD,CER DI:0.01UF,10%,50V	80009	283-5003-00
A68A4C4059	283-5003-00		CAP,FXD,CER DI:0.01UF,10%,50V	80009	283-5003-00
A68A4CR1010	152-5008-00		DIODE,RECT:.,400V,1A,MONOLITHIC COM-CATH;BA W79D,SOT-89,12MM TR	80009	152-5008-00
A68A4CR1011	152-5008-00		DIODE,RECT:.,400V,1A,MONOLITHIC COM-CATH;BA W79D,SOT-89,12MM TR	80009	152-5008-00
A68A4CR1012	152-5000-00		SEMICON DVC,DI:SW,SI,70V,COM CATHODE	80009	152-5000-00
A68A4CR1016	152-5008-00		DIODE,RECT:.,400V,1A,MONOLITHIC COM-CATH;BA W79D,SOT-89,12MM TR	80009	152-5008-00
A68A4CR1018	152-5008-00		DIODE,RECT:.,400V,1A,MONOLITHIC COM-CATH;BA W79D,SOT-89,12MM TR	80009	152-5008-00
A68A4CR1020	152-5005-00		DIODE,SIG:,ULTRA FAST;70V,0.15A,6NS,COM-ANO DE;BAW56,SOT-23,8MM TR	80009	152-5005-00
A68A4CR1030	152-5005-00		DIODE,SIG:,ULTRA FAST;70V,0.15A,6NS,COM-ANO DE;BAW56,SOT-23,8MM TR	80009	152-5005-00
A68A4CR1035	152-5005-00		DIODE,SIG:,ULTRA FAST;70V,0.15A,6NS,COM-ANO DE;BAW56,SOT-23,8MM TR	80009	152-5005-00
A68A4CR1060	152-5008-00		DIODE,RECT:.,400V,1A,MONOLITHIC COM-CATH;BA W79D,SOT-89,12MM TR	80009	152-5008-00
A68A4CR1061	152-5008-00		DIODE,RECT:.,400V,1A,MONOLITHIC COM-CATH;BA W79D,SOT-89,12MM TR	80009	152-5008-00
A68A4CR2010	152-5008-00		DIODE,RECT:.,400V,1A,MONOLITHIC COM-CATH;BA W79D,SOT-89,12MM TR	80009	152-5008-00
A68A4CR2011	152-5008-00		DIODE,RECT:.,400V,1A,MONOLITHIC COM-CATH;BA W79D,SOT-89,12MM TR	80009	152-5008-00
A68A4CR2012	152-5008-00		DIODE,RECT:.,400V,1A,MONOLITHIC COM-CATH;BA W79D,SOT-89,12MM TR	80009	152-5008-00
A68A4CR2013	152-5008-00		DIODE,RECT:.,400V,1A,MONOLITHIC COM-CATH;BA W79D,SOT-89,12MM TR	80009	152-5008-00
A68A4CR2060	152-5008-00		DIODE,RECT:.,400V,1A,MONOLITHIC COM-CATH;BA W79D,SOT-89,12MM TR	80009	152-5008-00
A68A4CR2061	152-5008-00		DIODE,RECT:.,400V,1A,MONOLITHIC COM-CATH;BA W79D,SOT-89,12MM TR	80009	152-5008-00
A68A4CR2062	152-5008-00		DIODE,RECT:.,400V,1A,MONOLITHIC COM-CATH;BA W79D,SOT-89,12MM TR	80009	152-5008-00
A68A4CR2063	152-5008-00		DIODE,RECT:.,400V,1A,MONOLITHIC COM-CATH;BA W79D,SOT-89,12MM TR	80009	152-5008-00
A68A4CR3010	152-5008-00		DIODE,RECT:.,400V,1A,MONOLITHIC COM-CATH;BA W79D,SOT-89,12MM TR	80009	152-5008-00
A68A4CR3011	152-5008-00		DIODE,RECT:.,400V,1A,MONOLITHIC COM-CATH;BA W79D,SOT-89,12MM TR	80009	152-5008-00
A68A4CR3012	152-5008-00		DIODE,RECT:.,400V,1A,MONOLITHIC COM-CATH;BA W79D,SOT-89,12MM TR	80009	152-5008-00
A68A4CR3013	152-5008-00		DIODE,RECT:.,400V,1A,MONOLITHIC COM-CATH;BA W79D,SOT-89,12MM TR	80009	152-5008-00
A68A4CR3060	152-5008-00		DIODE,RECT:.,400V,1A,MONOLITHIC COM-CATH;BA W79D,SOT-89,12MM TR	80009	152-5008-00

Replaceable Electrical Parts
494A/494AP Service Vol.2

Component No.	Tektronix Part No.	Serial/Assembly No. Effective	Discont	Name & Description	Mfr. Code	Mfr. Part No.
A68A4CR3061	152-5008-00			DIODE, RECT: , ; 400V, 1A, MONOLITHIC COM-CATH; BA W79D, SOT-89, 12MM TR	80009	152-5008-00
A68A4CR3062	152-5008-00			DIODE, RECT: , ; 400V, 1A, MONOLITHIC COM-CATH; BA W79D, SOT-89, 12MM TR	80009	152-5008-00
A68A4CR3063	152-5008-00			DIODE, RECT: , ; 400V, 1A, MONOLITHIC COM-CATH; BA W79D, SOT-89, 12MM TR	80009	152-5008-00
A68A4CR4050	152-5005-00			DIODE, SIG: , ULTRA FAST; 70V, 0.15A, 6NS, COM-ANO DE; BAW56, SOT-23, 8MM TR	80009	152-5005-00
A68A4CR4055	152-5005-00			DIODE, SIG: , ULTRA FAST; 70V, 0.15A, 6NS, COM-ANO DE; BAW56, SOT-23, 8MM TR	80009	152-5005-00
A68A4CR4060	152-5008-00			DIODE, RECT: , ; 400V, 1A, MONOLITHIC COM-CATH; BA W79D, SOT-89, 12MM TR	80009	152-5008-00
A68A4CR4061	152-5008-00			DIODE, RECT: , ; 400V, 1A, MONOLITHIC COM-CATH; BA W79D, SOT-89, 12MM TR	80009	152-5008-00
A68A4L1010	108-5024-00			COIL, RF:	80009	108-5024-00
A68A4L1012	108-5024-00			COIL, RF:	80009	108-5024-00
A68A4L1018	108-5024-00			COIL, RF:	80009	108-5024-00
A68A4L1040	108-1363-00			COIL, RF: FXD, 2UH, 10%	TK1345	108-1363-00
A68A4L1050	108-1363-00			COIL, RF: FXD, 2UH, 10%	TK1345	108-1363-00
A68A4L1052	108-1363-00			COIL, RF: FXD, 2UH, 10%	TK1345	108-1363-00
A68A4L1058	108-5024-00			COIL, RF:	80009	108-5024-00
A68A4L2010	108-5024-00			COIL, RF:	80009	108-5024-00
A68A4L2018	108-5024-00			COIL, RF:	80009	108-5024-00
A68A4L2056	108-5024-00			COIL, RF:	80009	108-5024-00
A68A4L2058	108-5024-00			COIL, RF:	80009	108-5024-00
A68A4L3010	108-5024-00			COIL, RF:	80009	108-5024-00
A68A4L3015	108-5024-00			COIL, RF:	80009	108-5024-00
A68A4L3029	108-0964-00			COIL, RF: FIXED, 1.2 UH	80009	108-0964-00
A68A4L3040	108-0964-00			COIL, RF: FIXED, 1.2 UH	80009	108-0964-00
A68A4L3056	108-5024-00			COIL, RF:	80009	108-5024-00
A68A4L3058	108-5024-00			COIL, RF:	80009	108-5024-00
A68A4L4010	108-5024-00			COIL, RF:	80009	108-5024-00
A68A4L4015	108-5024-00			COIL, RF:	80009	108-5024-00
A68A4L4040	108-5024-00			COIL, RF:	80009	108-5024-00
A68A4L4045	108-5024-00			COIL, RF:	80009	108-5024-00
A68A4L4050	108-5024-00			COIL, RF:	80009	108-5024-00
A68A4L4055	108-5024-00			COIL, RF:	80009	108-5024-00
A68A4L4060	108-5024-00			COIL, RF:	80009	108-5024-00
A68A4L4061	108-5024-00			COIL, RF:	80009	108-5024-00
A68A4Q1020	151-5000-00			TRANSISTOR, SIG: BIPOLAR, PNP; 40V, 200MA, 250MHZ ,AMPLIFIER; MMBT3906L, TO-236/SOT-23, 8MM T&R	04713	MMBT3906LT1
A68A4Q1025	151-5000-00			TRANSISTOR, SIG: BIPOLAR, PNP; 40V, 200MA, 250MHZ ,AMPLIFIER; MMBT3906L, TO-236/SOT-23, 8MM T&R	04713	MMBT3906LT1
A68A4Q1027	151-5000-00			TRANSISTOR, SIG: BIPOLAR, PNP; 40V, 200MA, 250MHZ ,AMPLIFIER; MMBT3906L, TO-236/SOT-23, 8MM T&R	04713	MMBT3906LT1
A68A4Q1050	151-5000-00			TRANSISTOR, SIG: BIPOLAR, PNP; 40V, 200MA, 250MHZ ,AMPLIFIER; MMBT3906L, TO-236/SOT-23, 8MM T&R	04713	MMBT3906LT1
A68A4Q2010	151-5000-00			TRANSISTOR, SIG: BIPOLAR, PNP; 40V, 200MA, 250MHZ ,AMPLIFIER; MMBT3906L, TO-236/SOT-23, 8MM T&R	04713	MMBT3906LT1
A68A4Q2045	151-5000-00			TRANSISTOR, SIG: BIPOLAR, PNP; 40V, 200MA, 250MHZ ,AMPLIFIER; MMBT3906L, TO-236/SOT-23, 8MM T&R	04713	MMBT3906LT1
A68A4Q2050	151-5000-00			TRANSISTOR, SIG: BIPOLAR, PNP; 40V, 200MA, 250MHZ ,AMPLIFIER; MMBT3906L, TO-236/SOT-23, 8MM T&R	04713	MMBT3906LT1
A68A4Q2053	151-5000-00			TRANSISTOR, SIG: BIPOLAR, PNP; 40V, 200MA, 250MHZ ,AMPLIFIER; MMBT3906L, TO-236/SOT-23, 8MM T&R	04713	MMBT3906LT1
A68A4Q3015	151-5000-00			TRANSISTOR, SIG: BIPOLAR, PNP; 40V, 200MA, 250MHZ ,AMPLIFIER; MMBT3906L, TO-236/SOT-23, 8MM T&R	04713	MMBT3906LT1

Replaceable Electrical Parts
494A/494AP Service Vol.2

Component No.	Tektronix	Serial/Assembly No.		Name & Description	Mfr.	Mfr. Part No.
	Part No.	Effective	Discont.		Code	
A68A4Q3020	151-5000-00			TRANSISTOR, SIG: BIPOLAR, PNP; 40V, 200MA, 250MHZ , AMPLIFIER; MMBT3906L, TO-236/SOT-23, 8MM T&R	04713	MMBT3906LT1
A68A4Q3050	151-5000-00			TRANSISTOR, SIG: BIPOLAR, PNP; 40V, 200MA, 250MHZ , AMPLIFIER; MMBT3906L, TO-236/SOT-23, 8MM T&R	04713	MMBT3906LT1
A68A4Q3055	151-5000-00			TRANSISTOR, SIG: BIPOLAR, PNP; 40V, 200MA, 250MHZ , AMPLIFIER; MMBT3906L, TO-236/SOT-23, 8MM T&R	04713	MMBT3906LT1
A68A4Q4040	151-5000-00			TRANSISTOR, SIG: BIPOLAR, PNP; 40V, 200MA, 250MHZ , AMPLIFIER; MMBT3906L, TO-236/SOT-23, 8MM T&R	04713	MMBT3906LT1
A68A4Q4050	151-5000-00			TRANSISTOR, SIG: BIPOLAR, PNP; 40V, 200MA, 250MHZ , AMPLIFIER; MMBT3906L, TO-236/SOT-23, 8MM T&R	04713	MMBT3906LT1
A68A4R700	315-0822-00			RES, FXD, FILM: 8.2K OHM, 5%, 0.25W (OPTION 07 ONLY)	80009	315-0822-00
A68A4R701	315-0822-00			RES, FXD, FILM: 8.2K OHM, 5%, 0.25W (OPTION 07 ONLY)	80009	315-0822-00
A68A4R1010	321-5011-00			RES, FXD, FILM: 274 OHM, 1%, 0.125W	80009	321-5011-00
A68A4R1012	321-5007-00			RES, FXD, FILM: 121 OHM, 1%, 0.125W	80009	321-5007-00
A68A4R1014	321-5043-00			RES, FXD, FILM: 47.5 OHM, 1%, 0.125W	80009	321-5043-00
A68A4R1015	321-5007-00			RES, FXD, FILM: 121 OHM, 1%, 0.125W	80009	321-5007-00
A68A4R1016	321-5007-00			RES, FXD, FILM: 121 OHM, 1%, 0.125W	80009	321-5007-00
A68A4R1018	321-5021-00			RES, FXD, FILM: 1.82K, 1%, 0.125W	80009	321-5021-00
A68A4R1019	321-5020-00			RES, FXD, FILM: 1.5K, 1%, 0.125W, T&R	80009	321-5020-00
A68A4R1020	321-5020-00			RES, FXD, FILM: 1.5K, 1%, 0.125W, T&R	80009	321-5020-00
A68A4R1021	321-5021-00			RES, FXD, FILM: 1.82K, 1%, 0.125W	80009	321-5021-00
A68A4R1022	321-5021-00			RES, FXD, FILM: 1.82K, 1%, 0.125W	80009	321-5021-00
A68A4R1023	321-5020-00			RES, FXD, FILM: 1.5K, 1%, 0.125W, T&R	80009	321-5020-00
A68A4R1024	321-5030-00			RES, FXD, FILM: 10.0K, 1%, 0.125W	80009	321-5030-00
A68A4R1025	321-5030-00			RES, FXD, FILM: 10.0K, 1%, 0.125W	80009	321-5030-00
A68A4R1026	321-5030-00			RES, FXD, FILM: 10.0K, 1%, 0.125W	80009	321-5030-00
A68A4R1027	311-0622-00			RES, VAR, NONW: TRMR, 100 OHM, 0.5W	80009	311-0622-00
A68A4R1029	321-5030-00			RES, FXD, FILM: 10.0K, 1%, 0.125W	80009	321-5030-00
A68A4R1030	321-5011-00			RES, FXD, FILM: 274 OHM, 1%, 0.125W	80009	321-5011-00
A68A4R1031	321-5030-00			RES, FXD, FILM: 10.0K, 1%, 0.125W	80009	321-5030-00
A68A4R1032	321-5030-00			RES, FXD, FILM: 10.0K, 1%, 0.125W	80009	321-5030-00
A68A4R1050	321-5030-00			RES, FXD, FILM: 10.0K, 1%, 0.125W	80009	321-5030-00
A68A4R1051	321-5030-00			RES, FXD, FILM: 10.0K, 1%, 0.125W	80009	321-5030-00
A68A4R1053	321-5021-00			RES, FXD, FILM: 1.82K, 1%, 0.125W	80009	321-5021-00
A68A4R1055	321-5020-00			RES, FXD, FILM: 1.5K, 1%, 0.125W, T&R	80009	321-5020-00
A68A4R1057	321-5007-00			RES, FXD, FILM: 121 OHM, 1%, 0.125W	80009	321-5007-00
A68A4R2010	321-5012-00			RES, FXD, FILM: 332 OHM, 1%, 0.125W	80009	321-5012-00
A68A4R2011	321-5003-00			RES, FXD, FILM: 18.2 OHM, 1%, 0.125W	57668	MCR18EZHFW 18E2
A68A4R2012	321-5012-00			RES, FXD, FILM: 332 OHM, 1%, 0.125W	80009	321-5012-00
A68A4R2014	321-5007-00			RES, FXD, FILM: 121 OHM, 1%, 0.125W	80009	321-5007-00
A68A4R2015	321-5006-00			RES, FXD, FILM: 100 OHM, 1%, 0.125W	80009	321-5006-00
A68A4R2016	321-5044-00			RES, FXD, FILM: 56.2 OHM, 1%, 0.125W	01121	BCD56R2FT
A68A4R2017	321-5006-00			RES, FXD, FILM: 100 OHM, 1%, 0.125W	80009	321-5006-00
A68A4R2018	321-5007-00			RES, FXD, FILM: 121 OHM, 1%, 0.125W	80009	321-5007-00
A68A4R2020	321-5021-00			RES, FXD, FILM: 1.82K, 1%, 0.125W	80009	321-5021-00
A68A4R2021	321-5020-00			RES, FXD, FILM: 1.5K, 1%, 0.125W, T&R	80009	321-5020-00
A68A4R2023	321-5021-00			RES, FXD, FILM: 1.82K, 1%, 0.125W	80009	321-5021-00
A68A4R2024	321-5020-00			RES, FXD, FILM: 1.5K, 1%, 0.125W, T&R	80009	321-5020-00
A68A4R2026	321-5030-00			RES, FXD, FILM: 10.0K, 1%, 0.125W	80009	321-5030-00
A68A4R2027	321-5030-00			RES, FXD, FILM: 10.0K, 1%, 0.125W	80009	321-5030-00
A68A4R2028	321-5030-00			RES, FXD, FILM: 10.0K, 1%, 0.125W	80009	321-5030-00
A68A4R2029	321-5030-00			RES, FXD, FILM: 10.0K, 1%, 0.125W	80009	321-5030-00
A68A4R2050	321-5030-00			RES, FXD, FILM: 10.0K, 1%, 0.125W	80009	321-5030-00
A68A4R2051	321-5030-00			RES, FXD, FILM: 10.0K, 1%, 0.125W	80009	321-5030-00
A68A4R2052	321-5030-00			RES, FXD, FILM: 10.0K, 1%, 0.125W	80009	321-5030-00
A68A4R2053	321-5030-00			RES, FXD, FILM: 10.0K, 1%, 0.125W	80009	321-5030-00

Replaceable Electrical Parts
494A/494AP Service Vol.2

Component No.	Tektronix Part No.	Serial/Assembly No. Effective Dscont	Name & Description	Mfr. Code	Mfr. Part No.
A68A4R2054	321-5020-00		RES,FXD,FILM:1.5K,1%,0.125W,T&R	80009	321-5020-00
A68A4R2055	321-5021-00		RES,FXD,FILM:1.82K,1%,0.125W	80009	321-5021-00
A68A4R2056	321-5007-00		RES,FXD,FILM:121 OHM,1%,0.125W	80009	321-5007-00
A68A4R2057	321-5020-00		RES,FXD,FILM:1.5K,1%,0.125W,T&R	80009	321-5020-00
A68A4R2058	321-5021-00		RES,FXD,FILM:1.82K,1%,0.125W	80009	321-5021-00
A68A4R2059	321-5007-00		RES,FXD,FILM:121 OHM,1%,0.125W	80009	321-5007-00
A68A4R3010	321-5008-00		RES,FXD,FILM:150 OHM,1%,0.125W	80009	321-5008-00
A68A4R3011	321-5050-00		RES,FXD,FILM:33.2 OHM,1%,0.125W	57668	MCR18FWEA33E2
A68A4R3012	321-5008-00		RES,FXD,FILM:150 OHM,1%,0.125W	80009	321-5008-00
A68A4R3013	321-5020-00		RES,FXD,FILM:1.5K,1%,0.125W,T&R	80009	321-5020-00
A68A4R3014	321-5007-00		RES,FXD,FILM:121 OHM,1%,0.125W	80009	321-5007-00
A68A4R3015	321-5007-00		RES,FXD,FILM:121 OHM,1%,0.125W	80009	321-5007-00
A68A4R3016	321-5030-00		RES,FXD,FILM:10.0K,1%,0.125W	80009	321-5030-00
A68A4R3017	321-5030-00		RES,FXD,FILM:10.0K,1%,0.125W	80009	321-5030-00
A68A4R3018	321-5021-00		RES,FXD,FILM:1.82K,1%,0.125W	80009	321-5021-00
A68A4R3019	321-5020-00		RES,FXD,FILM:1.5K,1%,0.125W,T&R	80009	321-5020-00
A68A4R3020	321-5021-00		RES,FXD,FILM:1.82K,1%,0.125W	80009	321-5021-00
A68A4R3022	321-5030-00		RES,FXD,FILM:10.0K,1%,0.125W	80009	321-5030-00
A68A4R3024	321-5030-00		RES,FXD,FILM:10.0K,1%,0.125W	80009	321-5030-00
A68A4R3049	321-5030-00		RES,FXD,FILM:10.0K,1%,0.125W	80009	321-5030-00
A68A4R3050	321-5030-00		RES,FXD,FILM:10.0K,1%,0.125W	80009	321-5030-00
A68A4R3051	321-5021-00		RES,FXD,FILM:1.82K,1%,0.125W	80009	321-5021-00
A68A4R3052	321-5007-00		RES,FXD,FILM:121 OHM,1%,0.125W	80009	321-5007-00
A68A4R3053	321-5020-00		RES,FXD,FILM:1.5K,1%,0.125W,T&R	80009	321-5020-00
A68A4R3054	321-5030-00		RES,FXD,FILM:10.0K,1%,0.125W	80009	321-5030-00
A68A4R3055	321-5030-00		RES,FXD,FILM:10.0K,1%,0.125W	80009	321-5030-00
A68A4R3056	321-5021-00		RES,FXD,FILM:1.82K,1%,0.125W	80009	321-5021-00
A68A4R3057	321-5020-00		RES,FXD,FILM:1.5K,1%,0.125W,T&R	80009	321-5020-00
A68A4R3059	321-5007-00		RES,FXD,FILM:121 OHM,1%,0.125W	80009	321-5007-00
A68A4R4010	321-5012-00		RES,FXD,FILM:332 OHM,1%,0.125W	80009	321-5012-00
A68A4R4012	321-5012-00		RES,FXD,FILM:332 OHM,1%,0.125W	80009	321-5012-00
A68A4R4030	321-5020-00		RES,FXD,FILM:1.5K,1%,0.125W,T&R	80009	321-5020-00
A68A4R4032	321-5021-00		RES,FXD,FILM:1.82K,1%,0.125W	80009	321-5021-00
A68A4R4048	321-5030-00		RES,FXD,FILM:10.0K,1%,0.125W	80009	321-5030-00
A68A4R4050	321-5030-00		RES,FXD,FILM:10.0K,1%,0.125W	80009	321-5030-00
A68A4R4051	321-5007-00		RES,FXD,FILM:121 OHM,1%,0.125W	80009	321-5007-00
A68A4R4052	321-5020-00		RES,FXD,FILM:1.5K,1%,0.125W,T&R	80009	321-5020-00
A68A4R4053	321-5021-00		RES,FXD,FILM:1.82K,1%,0.125W	80009	321-5021-00
A68A4R4054	321-5030-00		RES,FXD,FILM:10.0K,1%,0.125W	80009	321-5030-00
A68A4R4056	321-5030-00		RES,FXD,FILM:10.0K,1%,0.125W	80009	321-5030-00
A68A4R4057	321-5007-00		RES,FXD,FILM:121 OHM,1%,0.125W	80009	321-5007-00
A68A4R4058	321-5020-00		RES,FXD,FILM:1.5K,1%,0.125W,T&R	80009	321-5020-00
A68A4R4059	321-5021-00		RES,FXD,FILM:1.82K,1%,0.125W	80009	321-5021-00
A68A4R4060	321-5012-00		RES,FXD,FILM:332 OHM,1%,0.125W	80009	321-5012-00
A68A4R4062	321-5012-00		RES,FXD,FILM:332 OHM,1%,0.125W	80009	321-5012-00
A68A4S2030	260-2031-00		SWITCH,ROCKER:(7)SPST,30VDC,125MA	81073	76SB07S
A68A4T2025	120-1637-00		TRANSFORMER,RF:TOROID	TK1345	120-1637-00
A68A4T2035	120-1237-00		TRANSFORMER,RF:TOROID	80009	120-1237-00
A68A4T2040	120-1237-00		TRANSFORMER,RF:TOROID	80009	120-1237-00
A68A4T3040	120-1637-00		TRANSFORMER,RF:TOROID	TK1345	120-1637-00
A68A4TP1051	214-0579-00		TERM,TEST POINT:BRS CD PL	TK0858	ORDER BY DESCR
A68A4TP4020	214-0579-00		TERM,TEST POINT:BRS CD PL	TK0858	ORDER BY DESCR
A68A4U4035	156-5049-00		IC,DIGITAL:LSTTL,DEMUX/DECODER;BCD TO DECIMAL DECODER/DRIVER ONLY;74LS145,S016.150,TUBE	80009	156-5049-00
A68A5	670-8321-00		CIRCUIT BD ASSY:10DB GAIN STEPS	80009	670-8321-00
A68A5C1017	283-0111-00		CAP,FXD,CER DI:0.1UF,20%,50V	80009	283-0111-00
A68A5C1024	283-0111-00		CAP,FXD,CER DI:0.1UF,20%,50V	80009	283-0111-00

Replaceable Electrical Parts
494A/494AP Service Vol.2

Component No.	Tektronix	Serial/Assembly No.		Name & Description	Mfr.	Mfr. Part No.
	Part No.	Effective	Discnt		Code	
A68A5C1028	283-0107-00			CAP, FXD, CER DI: 51PF, 5%, 200V	04222	SR292A510JAA
A68A5C1039	283-0111-00			CAP, FXD, CER DI: 0.1UF, 20%, 50V	80009	283-0111-00
A68A5C1047	283-0111-00			CAP, FXD, CER DI: 0.1UF, 20%, 50V	80009	283-0111-00
A68A5C1057	283-0204-00			CAP, FXD, CER DI: 0.01UF, 20%, 50V	51406	RPE110Z5U103M50V
A68A5C1066	283-0111-00			CAP, FXD, CER DI: 0.1UF, 20%, 50V	80009	283-0111-00
A68A5C2013	283-0111-00			CAP, FXD, CER DI: 0.1UF, 20%, 50V	80009	283-0111-00
A68A5C2018	283-0111-00			CAP, FXD, CER DI: 0.1UF, 20%, 50V	80009	283-0111-00
A68A5C2020	283-0204-00			CAP, FXD, CER DI: 0.01UF, 20%, 50V	51406	RPE110Z5U103M50V
A68A5C2032	283-0204-00			CAP, FXD, CER DI: 0.01UF, 20%, 50V	51406	RPE110Z5U103M50V
A68A5C2046	283-0204-00			CAP, FXD, CER DI: 0.01UF, 20%, 50V	51406	RPE110Z5U103M50V
A68A5C2052	283-0204-00			CAP, FXD, CER DI: 0.01UF, 20%, 50V	51406	RPE110Z5U103M50V
A68A5C2055	283-0111-00			CAP, FXD, CER DI: 0.1UF, 20%, 50V	80009	283-0111-00
A68A5C2059	283-0107-00			CAP, FXD, CER DI: 51PF, 5%, 200V	04222	SR292A510JAA
A68A5C3042	283-0111-00			CAP, FXD, CER DI: 0.1UF, 20%, 50V	80009	283-0111-00
A68A5C3045	283-0204-00			CAP, FXD, CER DI: 0.01UF, 20%, 50V	51406	RPE110Z5U103M50V
A68A5C3046	283-0111-00			CAP, FXD, CER DI: 0.1UF, 20%, 50V	80009	283-0111-00
A68A5C4024	283-0111-00			CAP, FXD, CER DI: 0.1UF, 20%, 50V	80009	283-0111-00
A68A5C4028	283-0111-00			CAP, FXD, CER DI: 0.1UF, 20%, 50V	80009	283-0111-00
A68A5C4046	283-0111-00			CAP, FXD, CER DI: 0.1UF, 20%, 50V	80009	283-0111-00
A68A5C4054	283-0111-00			CAP, FXD, CER DI: 0.1UF, 20%, 50V	80009	283-0111-00
A68A5C4059	283-0111-00			CAP, FXD, CER DI: 0.1UF, 20%, 50V	80009	283-0111-00
A68A5C4064	283-0111-00			CAP, FXD, CER DI: 0.1UF, 20%, 50V	80009	283-0111-00
A68ASCR1053	152-0524-00			DIODE, SIG: , PIN: 100V, 0.4PF, 2.5 OHM; MA47600, D 0-35	28480	5082-1779
A68A5Q1036	151-0282-00			TRANSISTOR, SIG: BIPOLAR, NPN; 12V, 50MA, 900MHZ, AMPLIFIER; 2N5179, TO-72	80009	151-0282-00
A68A5Q2015	151-0301-00			TRANSISTOR, SIG: BIPOLAR, PNP; 60V, 600MA, 200MHZ , AMPLIFIER; 2N2907A, TO-18	80009	151-0301-00
A68A5Q2027	151-0282-00			TRANSISTOR, SIG: BIPOLAR, NPN; 12V, 50MA, 900MHZ, AMPLIFIER; 2N5179, TO-72	80009	151-0282-00
A68A5Q2043	151-0282-00			TRANSISTOR, SIG: BIPOLAR, NPN; 12V, 50MA, 900MHZ, AMPLIFIER; 2N5179, TO-72	80009	151-0282-00
A68A5Q2056	151-0282-00			TRANSISTOR, SIG: BIPOLAR, NPN; 12V, 50MA, 900MHZ, AMPLIFIER; 2N5179, TO-72	80009	151-0282-00
A68A5Q3016	151-0282-00			TRANSISTOR, SIG: BIPOLAR, NPN; 12V, 50MA, 900MHZ, AMPLIFIER; 2N5179, TO-72	80009	151-0282-00
A68A5Q3055	151-0282-00			TRANSISTOR, SIG: BIPOLAR, NPN; 12V, 50MA, 900MHZ, AMPLIFIER; 2N5179, TO-72	80009	151-0282-00
A68A5Q3064	151-0650-00			TRANSISTOR, SIG: BIPOLAR, NPN; 25V, 300MA, 1.4GHZ , AMPLIFIER; NE74114/2SC1252, TO-39	S0545	2SC1252
A68A5Q4039	151-0301-00			TRANSISTOR, SIG: BIPOLAR, PNP; 60V, 600MA, 200MHZ , AMPLIFIER; 2N2907A, TO-18	80009	151-0301-00
A68A5R1016	315-0221-00			RES, FXD, FILM: 220 OHM, 5%, 0.25W	80009	315-0221-00
A68A5R1022	315-0151-00			RES, FXD, FILM: 150 OHM, 5%, 0.25W	80009	315-0151-00
A68A5R1026	315-0681-00			RES, FXD, FILM: 680 OHM, 5%, 0.25W	80009	315-0681-00
A68A5R1031	315-0101-00			RES, FXD, FILM: 100 OHM, 5%, 0.25W	80009	315-0101-00
A68A5R1032	315-0390-00			RES, FXD, FILM: 39 OHM, 5%, 0.25W	80009	315-0390-00
A68A5R1041	315-0681-00			RES, FXD, FILM: 680 OHM, 5%, 0.25W	80009	315-0681-00
A68A5R1046	315-0470-00			RES, FXD, FILM: 47 OHM, 5%, 0.25W	80009	315-0470-00
A68A5R1050	315-0470-00			RES, FXD, FILM: 47 OHM, 5%, 0.25W	80009	315-0470-00
A68A5R1052	321-0239-00			RES, FXD, FILM: 3.01K OHM, 1%, 0.125W, TC=TO	80009	321-0239-00
A68A5R1056	321-0058-00			RES, FXD, FILM: 39.2 OHM, 0.5%, 0.125W, TC=TO	80009	321-0058-00
A68A5R1060	321-0194-00			RES, FXD, FILM: 1.02K OHM, 1%, 0.125W, TC=TO	07716	CEAD10200F
A68A5R1062	321-0164-00			RES, FXD, FILM: 499 OHM, 1%, 0.125W, TC=TO	19701	5043ED499ROF
A68A5R1064	321-0065-00			RES, FXD, FILM: 46.4 OHM, 1%, 0.125W, TC=TO	80009	321-0065-00
A68A5R2011	315-0472-00			RES, FXD, FILM: 4.7K OHM, 5%, 0.25W	80009	315-0472-00
A68A5R2012	315-0472-00			RES, FXD, FILM: 4.7K OHM, 5%, 0.25W	80009	315-0472-00
A68A5R2018	315-0104-00			RES, FXD, FILM: 100K OHM, 5%, 0.25W	80009	315-0104-00

Replaceable Electrical Parts
494A/494AP Service Vol. 2

Component No.	Tektronix Part No.	Serial/Assembly No. Effective Dscnt	Name & Description	Mfr. Code	Mfr. Part No.
A68A5R2023	315-0681-00		RES, FXD, FILM: 680 OHM, 5%, 0.25W	80009	315-0681-00
A68A5R2025	311-0635-00		RES, VAR, NONWV: TRMR, 1K OHM, 0.5W	32997	3329H-L58-102
A68A5R2031	321-0194-00		RES, FXD, FILM: 1.02K OHM, 1%, 0.125W, TC=TO	07716	CEAD10200F
A68A5R2034	321-0164-00		RES, FXD, FILM: 499 OHM, 1%, 0.125W, TC=TO	19701	5043ED499ROF
A68A5R2035	321-0065-00		RES, FXD, FILM: 46.4 OHM, 1%, 0.125W, TC=TO	80009	321-0065-00
A68A5R2039	321-0130-00		RES, FXD, FILM: 221 OHM, 1%, 0.125W, TC=TO	80009	321-0130-00
A68A5R2042	315-0390-00		RES, FXD, FILM: 39 OHM, 5%, 0.25W	80009	315-0390-00
A68A5R2048	321-0097-00		RES, FXD, FILM: 100 OHM, 1%, 0.125W, TC=TO	91637	CMF551166100ROF
A68A5R2051	315-0152-00		RES, FXD, FILM: 1.5K OHM, 5%, 0.25W	80009	315-0152-00
A68A5R2053	315-0152-00		RES, FXD, FILM: 1.5K OHM, 5%, 0.25W	80009	315-0152-00
A68A5R2057	315-0681-00		RES, FXD, FILM: 680 OHM, 5%, 0.25W	80009	315-0681-00
A68A5R2063	315-0101-00		RES, FXD, FILM: 100 OHM, 5%, 0.25W	80009	315-0101-00
A68A5R2069	301-0201-00		RES, FXD, FILM: 200 OHM, 5%, 0.5W	80009	301-0201-00
A68A5R3014	315-0472-00		RES, FXD, FILM: 4.7K OHM, 5%, 0.25W	80009	315-0472-00
A68A5R3015	315-0390-00		RES, FXD, FILM: 39 OHM, 5%, 0.25W	80009	315-0390-00
A68A5R3022	315-0222-00		RES, FXD, FILM: 2.2K OHM, 5%, 0.25W	80009	315-0222-00
A68A5R3026	315-0222-00		RES, FXD, FILM: 2.2K OHM, 5%, 0.25W	80009	315-0222-00
A68A5R3029	321-0032-00		RES, FXD, FILM: 21.0 OHM, 1%, 0.125W, TC=TO	80009	321-0032-00
A68A5R3035	311-0622-00		RES, VAR, NONWV: TRMR, 100 OHM, 0.5W	80009	311-0622-00
A68A5R3038	321-0026-00		RES, FXD, FILM: 18.2 OHM, 1%, 0.125W, TC=TO	80009	321-0026-00
A68A5R3039	315-0104-00		RES, FXD, FILM: 100K OHM, 5%, 0.25W	80009	315-0104-00
A68A5R3044	315-0101-00		RES, FXD, FILM: 100 OHM, 5%, 0.25W	80009	315-0101-00
A68A5R3048	315-0222-00		RES, FXD, FILM: 2.2K OHM, 5%, 0.25W	80009	315-0222-00
A68A5R3050	321-0143-00		RES, FXD, FILM: 301 OHM, 1%, 0.125W, TC=TO	07716	CEAD301ROF
A68A5R3052	315-0390-00		RES, FXD, FILM: 39 OHM, 5%, 0.25W	80009	315-0390-00
A68A5R3059	315-0681-00		RES, FXD, FILM: 680 OHM, 5%, 0.25W	80009	315-0681-00
A68A5R4013	321-0160-00		RES, FXD, FILM: 453 OHM, 1%, 0.125W, MI	19701	5043ED453ROF
A68A5R4026	315-0151-00		RES, FXD, FILM: 150 OHM, 5%, 0.25W	80009	315-0151-00
A68A5R4030	315-0102-00		RES, FXD, FILM: 1K OHM, 5%, 0.25W	80009	315-0102-00
A68A5R4033	315-0102-00		RES, FXD, FILM: 1K OHM, 5%, 0.25W	80009	315-0102-00
A68A5R4035	315-0222-00		RES, FXD, FILM: 2.2K OHM, 5%, 0.25W	80009	315-0222-00
A68A5R4045	321-0111-00		RES, FXD, FILM: 140 OHM, 1%, 0.125W, TC=TO	07716	CEAD140ROF
A68A5R4049	315-0221-00		RES, FXD, FILM: 220 OHM, 5%, 0.25W	80009	315-0221-00
A68A5R4052	315-0181-00		RES, FXD, FILM: 180 OHM, 5%, 0.25W	80009	315-0181-00
A68A5R4061	315-0220-00		RES, FXD, FILM: 22 OHM, 5%, 0.25W	80009	315-0220-00
A68A5R4066	315-0220-00		RES, FXD, FILM: 22 OHM, 5%, 0.25W	80009	315-0220-00
A68A5T4019	120-1431-00		TRANSFORMER, RF: TOROID 2 WINDING ON FORM	80009	120-1431-00
A68A6	670-5532-04		CIRCUIT BD ASSY: 20DB GAIN STEPS	80009	670-5532-04
A68A6C1018	283-0204-00		CAP, FXD, CER DI: 0.01UF, 20%, 50V	51406	RPE110Z5U103M50V
A68A6C1019	283-0204-00		CAP, FXD, CER DI: 0.01UF, 20%, 50V	51406	RPE110Z5U103M50V
A68A6C1022	283-0204-00		CAP, FXD, CER DI: 0.01UF, 20%, 50V	51406	RPE110Z5U103M50V
A68A6C1026	283-0204-00		CAP, FXD, CER DI: 0.01UF, 20%, 50V	51406	RPE110Z5U103M50V
A68A6C1031	283-0204-00		CAP, FXD, CER DI: 0.01UF, 20%, 50V	51406	RPE110Z5U103M50V
A68A6C1041	283-0111-00		CAP, FXD, CER DI: 0.1UF, 20%, 50V	80009	283-0111-00
A68A6C1042	283-0204-00		CAP, FXD, CER DI: 0.01UF, 20%, 50V	51406	RPE110Z5U103M50V
A68A6C1045	283-0111-00		CAP, FXD, CER DI: 0.1UF, 20%, 50V	80009	283-0111-00
A68A6C2023	283-0204-00		CAP, FXD, CER DI: 0.01UF, 20%, 50V	51406	RPE110Z5U103M50V
A68A6C2032	283-0204-00		CAP, FXD, CER DI: 0.01UF, 20%, 50V	51406	RPE110Z5U103M50V
A68A6C2042	283-0204-00		CAP, FXD, CER DI: 0.01UF, 20%, 50V	51406	RPE110Z5U103M50V
A68A6C2051	283-0204-00		CAP, FXD, CER DI: 0.01UF, 20%, 50V	51406	RPE110Z5U103M50V
A68A6C2053	283-0204-00		CAP, FXD, CER DI: 0.01UF, 20%, 50V	51406	RPE110Z5U103M50V
A68A6C2059	283-0204-00		CAP, FXD, CER DI: 0.01UF, 20%, 50V	51406	RPE110Z5U103M50V
A68A6C2061	283-0204-00		CAP, FXD, CER DI: 0.01UF, 20%, 50V	51406	RPE110Z5U103M50V
A68A6C2069	283-0204-00		CAP, FXD, CER DI: 0.01UF, 20%, 50V	51406	RPE110Z5U103M50V
A68A6Q1025	151-0302-00		TRANSISTOR, SIG: BIPOLAR, NPN; 40V, 800MA, 300MHZ , AMPLIFIER; 2N2222A, TO-18	80009	151-0302-00
A68A6Q1035	151-0302-00		TRANSISTOR, SIG: BIPOLAR, NPN; 40V, 800MA, 300MHZ , AMPLIFIER; 2N2222A, TO-18	80009	151-0302-00

Replaceable Electrical Parts
494A/494AP Service Vol.2

Component No.	Tektronix	Serial/Assembly No.		Name & Description	Mfr.	Mfr. Part No.
	Part No.	Effective	Discont		Code	
A68A6Q1043	151-0302-00			TRANSISTOR, SIG: BIPOLAR, NPN; 40V, 800MA, 300MHZ , AMPLIFIER; 2N2222A, TO-18	80009	151-0302-00
A68A6Q1062	151-0301-00			TRANSISTOR, SIG: BIPOLAR, PNP; 60V, 600MA, 200MHZ , AMPLIFIER; 2N2907A, TO-18	80009	151-0301-00
A68A6Q2018	151-0301-00			TRANSISTOR, SIG: BIPOLAR, PNP; 60V, 600MA, 200MHZ , AMPLIFIER; 2N2907A, TO-18	80009	151-0301-00
A68A6Q2042	151-0301-00			TRANSISTOR, SIG: BIPOLAR, PNP; 60V, 600MA, 200MHZ , AMPLIFIER; 2N2907A, TO-18	80009	151-0301-00
A68A6R1015	321-0175-00			RES, FXD, FILM: 649 OHM, 1%, 0.125W, TC=TO	80009	321-0175-00
A68A6R1019	317-0101-00			RES, FXD, CMPSN: 100 OHM, 5%, 0.125W	80009	317-0101-00
A68A6R1024	321-0130-00			RES, FXD, FILM: 221 OHM, 1%, 0.125W, TC=TO	80009	321-0130-00
A68A6R1025	317-0331-00			RES, FXD, CMPSN: 330 OHM, 5%, 0.125W	80009	317-0331-00
A68A6R1026	321-0114-00			RES, FXD, FILM: 150 OHM, 1%, 0.125 W, TC=TO	80009	321-0114-00
A68A6R1032	321-0026-00			RES, FXD, FILM: 18.2 OHM, 1%, 0.125W, TC=TO	80009	321-0026-00
A68A6R1037	321-0143-00			RES, FXD, FILM: 301 OHM, 1%, 0.125W, TC=TO	07716	CEAD301ROF
A68A6R1038	317-0222-00			RES, FXD, CMPSN: 2.2K OHM, 5%, 0.125W	80009	317-0222-00
A68A6R1041	317-0331-00			RES, FXD, CMPSN: 330 OHM, 5%, 0.125W	80009	317-0331-00
A68A6R1042	321-0130-00			RES, FXD, FILM: 221 OHM, 1%, 0.125W, TC=TO	80009	321-0130-00
A68A6R1045	317-0331-00			RES, FXD, CMPSN: 330 OHM, 5%, 0.125W	80009	317-0331-00
A68A6R1049	315-0101-00			RES, FXD, FILM: 100 OHM, 5%, 0.25W	80009	315-0101-00
A68A6R1056	317-0104-00			RES, FXD, CMPSN: 100K OHM, 5%, 0.125W	80009	317-0104-00
A68A6R1064	315-0101-00			RES, FXD, FILM: 100 OHM, 5%, 0.25W	80009	315-0101-00
A68A6R1065	317-0222-00			RES, FXD, CMPSN: 2.2K OHM, 5%, 0.125W	80009	317-0222-00
A68A6R2014	315-0122-00			RES, FXD, FILM: 1.2K OHM, 5%, 0.25W	80009	315-0122-00
A68A6R2019	317-0222-00			RES, FXD, CMPSN: 2.2K OHM, 5%, 0.125W	80009	317-0222-00
A68A6R2021	317-0104-00			RES, FXD, CMPSN: 100K OHM, 5%, 0.125W	80009	317-0104-00
A68A6R2022	317-0222-00			RES, FXD, CMPSN: 2.2K OHM, 5%, 0.125W	80009	317-0222-00
A68A6R2023	311-0622-00			RES, VAR, NONW: TRMR, 100 OHM, 0.5W	80009	311-0622-00
A68A6R2026	315-0101-00			RES, FXD, FILM: 100 OHM, 5%, 0.25W	80009	315-0101-00
A68A6R2031	315-0101-00			RES, FXD, FILM: 100 OHM, 5%, 0.25W	80009	315-0101-00
A68A6R2039	317-0222-00			RES, FXD, CMPSN: 2.2K OHM, 5%, 0.125W	80009	317-0222-00
A68A6R2044	321-0114-00			RES, FXD, FILM: 150 OHM, 1%, 0.125 W, TC=TO	80009	321-0114-00
A68A6R2045	321-0085-00			RES, FXD, FILM: 75 OHM, 1%, 0.125W, TC=TO	80009	321-0085-00
A68A6R2046	317-0104-00			RES, FXD, CMPSN: 100K OHM, 5%, 0.125W	80009	317-0104-00
A68A6R2051	315-0102-00			RES, FXD, FILM: 1K OHM, 5%, 0.25W	80009	315-0102-00
A68A6R2052	315-0102-00			RES, FXD, FILM: 1K OHM, 5%, 0.25W	80009	315-0102-00
A68A6R2060	311-0622-00			RES, VAR, NONW: TRMR, 100 OHM, 0.5W	80009	311-0622-00
A68A6R2061	321-0097-00			RES, FXD, FILM: 100 OHM, 1%, 0.125W, TC=TO	91637	CMF55116G100ROF
A68A6R2062	321-0026-00			RES, FXD, FILM: 18.2 OHM, 1%, 0.125W, TC=TO	80009	321-0026-00
A68A6R2063	317-0222-00			RES, FXD, CMPSN: 2.2K OHM, 5%, 0.125W	80009	317-0222-00
A68A7	670-5533-03			CIRCUIT BD ASSY: BAND LEVELING	80009	670-5533-03
A68A7C1017	283-0111-00			CAP, FXD, CER DI: 0.1UF, 20%, 50V	80009	283-0111-00
A68A7C1021	283-0107-00			CAP, FXD, CER DI: 51PF, 5%, 200V	04222	SR292A510JAA
A68A7C1025	283-0111-00			CAP, FXD, CER DI: 0.1UF, 20%, 50V	80009	283-0111-00
A68A7C1032	283-0111-00			CAP, FXD, CER DI: 0.1UF, 20%, 50V	80009	283-0111-00
A68A7C1035	283-0111-00			CAP, FXD, CER DI: 0.1UF, 20%, 50V	80009	283-0111-00
A68A7C1039	283-0107-00			CAP, FXD, CER DI: 51PF, 5%, 200V	04222	SR292A510JAA
A68A7C1044	283-0111-00			CAP, FXD, CER DI: 0.1UF, 20%, 50V	80009	283-0111-00
A68A7C2015	283-0111-00			CAP, FXD, CER DI: 0.1UF, 20%, 50V	80009	283-0111-00
A68A7C2018	283-0111-00			CAP, FXD, CER DI: 0.1UF, 20%, 50V	80009	283-0111-00
A68A7C2023	283-0111-00			CAP, FXD, CER DI: 0.1UF, 20%, 50V	80009	283-0111-00
A68A7C2028	283-0204-00			CAP, FXD, CER DI: 0.01UF, 20%, 50V	51406	RPE11025U103M50V
A68A7C2029	283-0111-00			CAP, FXD, CER DI: 0.1UF, 20%, 50V	80009	283-0111-00
A68A7C2033	283-0111-00			CAP, FXD, CER DI: 0.1UF, 20%, 50V	80009	283-0111-00
A68A7C2034	283-0111-00			CAP, FXD, CER DI: 0.1UF, 20%, 50V	80009	283-0111-00
A68A7C2042	283-0111-00			CAP, FXD, CER DI: 0.1UF, 20%, 50V	80009	283-0111-00
A68A7C2043	283-0204-00			CAP, FXD, CER DI: 0.01UF, 20%, 50V	51406	RPE11025U103M50V
A68A7C2046	283-0111-00			CAP, FXD, CER DI: 0.1UF, 20%, 50V	80009	283-0111-00

Replaceable Electrical Parts
494A/494AP Service Vol. 2

Component No.	Tektronix		Serial/Assembly No.		Name & Description	Mfr. Code	Mfr. Part No.
	Part No.	Effective	Discnt				
A68A7CR2021	152-0524-00				DIODE, SIG: , PIN; 100V, 0.4PF, 2.5 OHM; MA47600, D 0-35	28480	5082-1779
A68A7Q1025	151-0282-00				TRANSISTOR, SIG: BIPOLAR, NPN; 12V, 50MA, 900MHZ, AMPLIFIER; 2N5179, TO-72	80009	151-0282-00
A68A7Q1031	151-0282-00				TRANSISTOR, SIG: BIPOLAR, NPN; 12V, 50MA, 900MHZ, AMPLIFIER; 2N5179, TO-72	80009	151-0282-00
A68A7Q1033	151-0282-00				TRANSISTOR, SIG: BIPOLAR, NPN; 12V, 50MA, 900MHZ, AMPLIFIER; 2N5179, TO-72	80009	151-0282-00
A68A7Q1041	151-0650-00				TRANSISTOR, SIG: BIPOLAR, NPN; 25V, 300MA, 1.4GHZ , AMPLIFIER; NE74114/2SC1252, TO-39	S0545	2SC1252
A68A7Q2015	151-0282-00				TRANSISTOR, SIG: BIPOLAR, NPN; 12V, 50MA, 900MHZ, AMPLIFIER; 2N5179, TO-72	80009	151-0282-00
A68A7Q2019	151-0282-00				TRANSISTOR, SIG: BIPOLAR, NPN; 12V, 50MA, 900MHZ, AMPLIFIER; 2N5179, TO-72	80009	151-0282-00
A68A7Q2046	151-0301-00				TRANSISTOR, SIG: BIPOLAR, PNP; 60V, 600MA, 200MHZ , AMPLIFIER; 2N2907A, TO-18	80009	151-0301-00
A68A7R1013	321-0130-00				RES, FXD, FILM: 221 OHM, 1%, 0.125W, TC=TO	80009	321-0130-00
A68A7R1014	317-0390-00				RES, FXD, CMPSN: 39 OHM, 5%, 0.125W	80009	317-0390-00
A68A7R1015	315-0681-00				RES, FXD, FILM: 680 OHM, 5%, 0.25W	80009	315-0681-00
A68A7R1016	317-0101-00				RES, FXD, CMPSN: 100 OHM, 5%, 0.125W	80009	317-0101-00
A68A7R1017	315-0390-00				RES, FXD, FILM: 39 OHM, 5%, 0.25W	80009	315-0390-00
A68A7R1019	315-0390-00				RES, FXD, FILM: 39 OHM, 5%, 0.25W	80009	315-0390-00
A68A7R1024	315-0681-00				RES, FXD, FILM: 680 OHM, 5%, 0.25W	80009	315-0681-00
A68A7R1025	321-0164-00				RES, FXD, FILM: 499 OHM, 1%, 0.125W, TC=TO	19701	5043ED499ROF
A68A7R1026	321-0194-00				RES, FXD, FILM: 1.02K OHM, 1%, 0.125W, TC=TO	07716	CEAD10200F
A68A7R1027	321-0065-00				RES, FXD, FILM: 46.4 OHM, 1%, 0.125W, TC=TO	80009	321-0065-00
A68A7R1028	315-0471-00				RES, FXD, FILM: 470 OHM, 5%, 0.25W	80009	315-0471-00
A68A7R1029	317-0390-00				RES, FXD, CMPSN: 39 OHM, 5%, 0.125W	80009	317-0390-00
A68A7R1031	321-0130-00				RES, FXD, FILM: 221 OHM, 1%, 0.125W, TC=TO	80009	321-0130-00
A68A7R1033	315-0681-00				RES, FXD, FILM: 680 OHM, 5%, 0.25W	80009	315-0681-00
A68A7R1035	315-0681-00				RES, FXD, FILM: 680 OHM, 5%, 0.25W	80009	315-0681-00
A68A7R1036	315-0220-00				RES, FXD, FILM: 22 OHM, 5%, 0.25W	80009	315-0220-00
A68A7R1037	315-0220-00				RES, FXD, FILM: 22 OHM, 5%, 0.25W	80009	315-0220-00
A68A7R1038	317-0101-00				RES, FXD, CMPSN: 100 OHM, 5%, 0.125W	80009	317-0101-00
A68A7R1044	315-0101-00				RES, FXD, FILM: 100 OHM, 5%, 0.25W	80009	315-0101-00
A68A7R1046	321-0065-00				RES, FXD, FILM: 46.4 OHM, 1%, 0.125W, TC=TO	80009	321-0065-00
A68A7R1047	315-0101-00				RES, FXD, FILM: 100 OHM, 5%, 0.25W	80009	315-0101-00
A68A7R1048	321-0164-00				RES, FXD, FILM: 499 OHM, 1%, 0.125W, TC=TO	19701	5043ED499ROF
A68A7R2017	315-0152-00				RES, FXD, FILM: 1.5K OHM, 5%, 0.25W	80009	315-0152-00
A68A7R2018	315-0152-00				RES, FXD, FILM: 1.5K OHM, 5%, 0.25W	80009	315-0152-00
A68A7R2021	315-0470-00				RES, FXD, FILM: 47 OHM, 5%, 0.25W	80009	315-0470-00
A68A7R2024	321-0041-00				RES, FXD, FILM: 26.1 OHM, 1%, 0.125W, TC=TO	80009	321-0041-00
A68A7R2025	321-0234-00				RES, FXD, FILM: 2.67K OHM, 1%, 0.125W, TC=TO	80009	321-0234-00
A68A7R2026	317-0470-00				RES, FXD, CMPSN: 47 OHM, 5%, 0.125W	80009	317-0470-00
A68A7R2028	317-0470-00				RES, FXD, CMPSN: 47 OHM, 5%, 0.125W	80009	317-0470-00
A68A7R2031	315-0470-00				RES, FXD, FILM: 47 OHM, 5%, 0.25W	80009	315-0470-00
A68A7R2033	315-0152-00				RES, FXD, FILM: 1.5K OHM, 5%, 0.25W	80009	315-0152-00
A68A7R2034	315-0152-00				RES, FXD, FILM: 1.5K OHM, 5%, 0.25W	80009	315-0152-00
A68A7R2036	321-0151-00				RES, FXD, FILM: 365 OHM, 1%, 0.125W, TC=TO	07716	CEAD365ROF
A68A7R2037	315-0102-00				RES, FXD, FILM: 1K OHM, 5%, 0.25W	80009	315-0102-00
A68A7R2038	315-0821-00				RES, FXD, FILM: 820 OHM, 5%, 0.25W	80009	315-0821-00
A68A7R2041	315-0104-00				RES, FXD, FILM: 100K OHM, 5%, 0.25W	80009	315-0104-00
A68A7R2042	321-0051-00				RES, FXD, FILM: 33.2 OHM, 1%, 0.125W, TC=TO	80009	321-0051-00
A68A7R2043	315-0471-00				RES, FXD, FILM: 470 OHM, 5%, 0.25W	80009	315-0471-00
A68A7R2045	315-0471-00				RES, FXD, FILM: 470 OHM, 5%, 0.25W	80009	315-0471-00
A68A7R2046	317-0103-00				RES, FXD, CMPSN: 10K OHM, 5%, 0.125W	80009	317-0103-00
A68A7T2013	120-0902-00				XFMR, TOROID:	80009	120-0902-00
A68A8	671-0094-00	B010100	B010181		CIRCUIT BD ASSY: 2ND FILTER SELECT	80009	671-0094-00

Replaceable Electrical Parts
494A/494AP Service Vol.2

Component No.	Tektronix Part No.	Serial/Assembly No. Effective	Descrt	Name & Description	Mfr. Code	Mfr. Part No.
A68A8	671-0094-01	B010182		CIRCUIT BD ASSY:2ND FILTER SELECT	80009	671-0094-01
A68A8	670-9598-01			CIRCUIT BD ASSY:2ND FILTER SELECT (OPTION 07 ONLY)	80009	670-9598-01
A68A8C1015	283-0204-00			CAP,FXD,CER DI:0.01UF,20%,50V	51406	RPE110Z5U103M50V
A68A8C1027	283-0204-00			CAP,FXD,CER DI:0.01UF,20%,50V	51406	RPE110Z5U103M50V
A68A8C1035	283-0204-00			CAP,FXD,CER DI:0.01UF,20%,50V	51406	RPE110Z5U103M50V
A68A8C1041	283-0204-00			CAP,FXD,CER DI:0.01UF,20%,50V	51406	RPE110Z5U103M50V
A68A8C1047	283-0204-00			CAP,FXD,CER DI:0.01UF,20%,50V	51406	RPE110Z5U103M50V
A68A8C1060	283-0204-00			CAP,FXD,CER DI:0.01UF,20%,50V	51406	RPE110Z5U103M50V
A68A8C1061	283-0204-00			CAP,FXD,CER DI:0.01UF,20%,50V	51406	RPE110Z5U103M50V
A68A8C2016	283-0204-00			CAP,FXD,CER DI:0.01UF,20%,50V	51406	RPE110Z5U103M50V
A68A8C2018	283-0204-00			CAP,FXD,CER DI:0.01UF,20%,50V	51406	RPE110Z5U103M50V
A68A8C2019	283-0204-00			CAP,FXD,CER DI:0.01UF,20%,50V	51406	RPE110Z5U103M50V
A68A8C2028	283-0204-00			CAP,FXD,CER DI:0.01UF,20%,50V	51406	RPE110Z5U103M50V
A68A8C2030	283-0204-00			CAP,FXD,CER DI:0.01UF,20%,50V	51406	RPE110Z5U103M50V
A68A8C2033	283-0204-00			CAP,FXD,CER DI:0.01UF,20%,50V	51406	RPE110Z5U103M50V
A68A8C2041	283-0204-00			CAP,FXD,CER DI:0.01UF,20%,50V	51406	RPE110Z5U103M50V
A68A8C2049	283-0359-00			CAP,FXD,CER DI:1000PF,10%,200V	04222	SR212A102KAA
A68A8C2054	283-0204-00			CAP,FXD,CER DI:0.01UF,20%,50V	51406	RPE110Z5U103M50V
A68A8C2058	281-0816-00			CAP,FXD,CER DI:82 PF,5%,100V	80009	281-0816-00
A68A8C2065	283-0204-00			CAP,FXD,CER DI:0.01UF,20%,50V	51406	RPE110Z5U103M50V
A68A8C2066	283-0204-00			CAP,FXD,CER DI:0.01UF,20%,50V	51406	RPE110Z5U103M50V
A68A8C2070	283-0111-00			CAP,FXD,CER DI:0.1UF,20%,50V	80009	283-0111-00
A68A8C3013	283-0111-00			CAP,FXD,CER DI:0.1UF,20%,50V	80009	283-0111-00
A68A8C3026	283-0204-00			CAP,FXD,CER DI:0.01UF,20%,50V	51406	RPE110Z5U103M50V
A68A8C3041	281-0153-00			CAP,VAR,AIR DI:1.7-10PF,250V	80009	281-0153-00
A68A8C3046	281-0811-00			CAP,FXD,CER DI:10PF,10%,100V	04222	SA102A100KAA
A68A8C3047	283-0838-00			CAP,FXD,CER DI:18PF,5%,50V	80009	283-0838-00
A68A8C3049	281-0816-00			CAP,FXD,CER DI:82 PF,5%,100V	80009	281-0816-00
A68A8C3066	283-0204-00			CAP,FXD,CER DI:0.01UF,20%,50V	51406	RPE110Z5U103M50V
A68A8C3067	283-0204-00			CAP,FXD,CER DI:0.01UF,20%,50V	51406	RPE110Z5U103M50V
A68A8C4046	283-0159-00			CAP,FXD,CER DI:18PF,5%,50V	05397	C315C180J565CA
A68A8C4048	281-0810-00			CAP,FXD,CER DI:5.6PF,+/-0.5PF,100V	04222	SA101A5R6DAA
A68A8C4048	283-0168-00			CAP,FXD,CER DI:12PF,5%,100V (OPTION 07 ONLY)	04222	SR151A120JAA
A68A8C4053	281-0810-00			CAP,FXD,CER DI:5.6PF,+/-0.5PF,100V	04222	SA101A5R6DAA
A68A8C4054	281-0810-00			CAP,FXD,CER DI:5.6PF,+/-0.5PF,100V	04222	SA101A5R6DAA
A68A8C4056	281-0810-00			CAP,FXD,CER DI:5.6PF,+/-0.5PF,100V	04222	SA101A5R6DAA
A68A8C4065	281-0811-00			CAP,FXD,CER DI:10PF,10%,100V	04222	SA102A100KAA
A68A8C4066	283-0159-00			CAP,FXD,CER DI:18PF,5%,50V	05397	C315C180J565CA
A68A8C4068	283-0111-00			CAP,FXD,CER DI:0.1UF,20%,50V	80009	283-0111-00
A68A8C4069	283-0838-00			CAP,FXD,CER DI:18PF,5%,50V	80009	283-0838-00
A68A8C5048	281-0153-00			CAP,VAR,AIR DI:1.7-10PF,250V	80009	281-0153-00
A68A8C5051	281-0810-00			CAP,FXD,CER DI:5.6PF,+/-0.5PF,100V	04222	SA101A5R6DAA
A68A8C5051	283-0168-00			CAP,FXD,CER DI:12PF,5%,100V (OPTION 07 ONLY)	04222	SR151A120JAA
A68A8C5055	281-0153-00			CAP,VAR,AIR DI:1.7-10PF,250V	80009	281-0153-00
A68A8C5057	281-0816-00			CAP,FXD,CER DI:82 PF,5%,100V	80009	281-0816-00
A68A8C5064	283-0204-00			CAP,FXD,CER DI:0.01UF,20%,50V	51406	RPE110Z5U103M50V
A68A8C5065	283-0204-00			CAP,FXD,CER DI:0.01UF,20%,50V	51406	RPE110Z5U103M50V
A68A8C5073	281-0816-00			CAP,FXD,CER DI:82 PF,5%,100V	80009	281-0816-00
A68A8C6041	283-0111-00			CAP,FXD,CER DI:0.1UF,20%,50V	80009	283-0111-00
A68A8C6056	283-0359-00			CAP,FXD,CER DI:1000PF,10%,200V	04222	SR212A102KAA
A68A8C6072	283-0204-00			CAP,FXD,CER DI:0.01UF,20%,50V	51406	RPE110Z5U103M50V
A68A8C6073	283-0204-00			CAP,FXD,CER DI:0.01UF,20%,50V	51406	RPE110Z5U103M50V
A68A8C7059	283-0204-00			CAP,FXD,CER DI:0.01UF,20%,50V	51406	RPE110Z5U103M50V
A68A8C7061	283-0204-00			CAP,FXD,CER DI:0.01UF,20%,50V	51406	RPE110Z5U103M50V
A68A8C8013	283-0111-00			CAP,FXD,CER DI:0.1UF,20%,50V	80009	283-0111-00

Replaceable Electrical Parts
494A/494AP Service Vol.2

Component No.	Tektronix Part No.	Serial/Assembly No. Effective Dscort	Name & Description	Mfr. Code	Mfr. Part No.
A68A8C8024	283-0204-00		CAP, FXD, CER DI:0.01UF, 20%, 50V	51406	RPE110Z5U103M50V
A68A8C8025	283-0204-00		CAP, FXD, CER DI:0.01UF, 20%, 50V	51406	RPE110Z5U103M50V
A68A8C8029	283-0204-00		CAP, FXD, CER DI:0.01UF, 20%, 50V	51406	RPE110Z5U103M50V
A68A8C8040	283-0204-00		CAP, FXD, CER DI:0.01UF, 20%, 50V	51406	RPE110Z5U103M50V
A68A8C8045	283-0204-00		CAP, FXD, CER DI:0.01UF, 20%, 50V	51406	RPE110Z5U103M50V
A68A8C8046	283-0204-00		CAP, FXD, CER DI:0.01UF, 20%, 50V	51406	RPE110Z5U103M50V
A68A8C8057	283-0204-00		CAP, FXD, CER DI:0.01UF, 20%, 50V	51406	RPE110Z5U103M50V
A68A8C8061	283-0204-00		CAP, FXD, CER DI:0.01UF, 20%, 50V	51406	RPE110Z5U103M50V
A68A8C8075	283-0204-00		CAP, FXD, CER DI:0.01UF, 20%, 50V	51406	RPE110Z5U103M50V
A68A8CR1017	152-0107-00		SEMICON DVC, DI:RECT, SI, 400 V, 400MA, A1	12969	"G727"
A68A8CR1019	152-0107-00		SEMICON DVC, DI:RECT, SI, 400 V, 400MA, A1	12969	"G727"
A68A8CR1020	152-0107-00		SEMICON DVC, DI:RECT, SI, 400 V, 400MA, A1	12969	"G727"
A68A8CR1022	152-0107-00		SEMICON DVC, DI:RECT, SI, 400 V, 400MA, A1	12969	"G727"
A68A8CR1025	152-0107-00		SEMICON DVC, DI:RECT, SI, 400 V, 400MA, A1	12969	"G727"
A68A8CR1029	152-0107-00		SEMICON DVC, DI:RECT, SI, 400 V, 400MA, A1	12969	"G727"
A68A8CR1038	152-0107-00		SEMICON DVC, DI:RECT, SI, 400 V, 400MA, A1	12969	"G727"
A68A8CR1040	152-0107-00		SEMICON DVC, DI:RECT, SI, 400 V, 400MA, A1	12969	"G727"
A68A8CR1050	152-0107-00		SEMICON DVC, DI:RECT, SI, 400 V, 400MA, A1	12969	"G727"
A68A8CR1052	152-0107-00		SEMICON DVC, DI:RECT, SI, 400 V, 400MA, A1	12969	"G727"
A68A8CR3068	152-0141-02		DIODE, SIG: , ULTRA FAST; 40V, 150MA, 4NS, 2PF; 1N4152, DO-35, T&R	80009	152-0141-02
A68A8CR7065	152-0107-00		SEMICON DVC, DI:RECT, SI, 400 V, 400MA, A1	12969	"G727"
A68A8CR7070	152-0107-00		SEMICON DVC, DI:RECT, SI, 400 V, 400MA, A1	12969	"G727"
A68A8CR7071	152-0107-00		SEMICON DVC, DI:RECT, SI, 400 V, 400MA, A1	12969	"G727"
A68A8CR7076	152-0107-00		SEMICON DVC, DI:RECT, SI, 400 V, 400MA, A1	12969	"G727"
A68A8CR8015	152-0107-00		SEMICON DVC, DI:RECT, SI, 400 V, 400MA, A1	12969	"G727"
A68A8CR8016	152-0107-00		SEMICON DVC, DI:RECT, SI, 400 V, 400MA, A1	12969	"G727"
A68A8CR8035	152-0107-00		SEMICON DVC, DI:RECT, SI, 400 V, 400MA, A1	12969	"G727"
A68A8CR8036	152-0107-00		SEMICON DVC, DI:RECT, SI, 400 V, 400MA, A1	12969	"G727"
A68A8CR8059	152-0107-00		SEMICON DVC, DI:RECT, SI, 400 V, 400MA, A1	12969	"G727"
A68A8CR8060	152-0107-00		SEMICON DVC, DI:RECT, SI, 400 V, 400MA, A1	12969	"G727"
A68A8L1019	108-0395-00		COIL, RF:FIXED, 64UH	80009	108-0395-00
A68A8L1025	108-0395-00		COIL, RF:FIXED, 64UH	80009	108-0395-00
A68A8L1032	108-0395-00		COIL, RF:FIXED, 64UH	80009	108-0395-00
A68A8L1045	108-0395-00		COIL, RF:FIXED, 64UH	80009	108-0395-00
A68A8L1055	108-0395-00		COIL, RF:FIXED, 64UH	80009	108-0395-00
A68A8L2013	108-0395-00		COIL, RF:FIXED, 64UH	80009	108-0395-00
A68A8L2059	108-0964-00		COIL, RF:FIXED, 1.2 UH	80009	108-0964-00
A68A8L2075	108-0395-00		COIL, RF:FIXED, 64UH	80009	108-0395-00
A68A8L5065	108-0964-00		COIL, RF:FIXED, 1.2 UH	80009	108-0964-00
A68A8L6056	108-0395-00		COIL, RF:FIXED, 64UH	80009	108-0395-00
A68A8L7075	108-0395-00		COIL, RF:FIXED, 64UH	80009	108-0395-00
A68A8L8020	108-0395-00		COIL, RF:FIXED, 64UH	80009	108-0395-00
A68A8L8040	108-0395-00		COIL, RF:FIXED, 64UH	80009	108-0395-00
A68A8L8061	108-0395-00		COIL, RF:FIXED, 64UH	80009	108-0395-00
A68A8L8070	108-0395-00		COIL, RF:FIXED, 64UH	80009	108-0395-00
A68A8Q2020	151-0301-00		TRANSISTOR, SIG: BIPOLAR, PNP; 60V, 600MA, 200MHZ ,AMPLIFIER; 2N2907A, TO-18	80009	151-0301-00
A68A8Q2028	151-0301-00		TRANSISTOR, SIG: BIPOLAR, PNP; 60V, 600MA, 200MHZ ,AMPLIFIER; 2N2907A, TO-18	80009	151-0301-00
A68A8Q2035	151-0301-00		TRANSISTOR, SIG: BIPOLAR, PNP; 60V, 600MA, 200MHZ ,AMPLIFIER; 2N2907A, TO-18	80009	151-0301-00
A68A8Q2040	151-0301-00		TRANSISTOR, SIG: BIPOLAR, PNP; 60V, 600MA, 200MHZ ,AMPLIFIER; 2N2907A, TO-18	80009	151-0301-00
A68A8Q2055	151-0301-00		TRANSISTOR, SIG: BIPOLAR, PNP; 60V, 600MA, 200MHZ ,AMPLIFIER; 2N2907A, TO-18	80009	151-0301-00
A68A8Q6065	151-0301-00		TRANSISTOR, SIG: BIPOLAR, PNP; 60V, 600MA, 200MHZ ,AMPLIFIER; 2N2907A, TO-18	80009	151-0301-00

Replaceable Electrical Parts
494A/494AP Service Vol.2

Component No.	Tektronix Part No.	Serial/Assembly No.		Name & Description	Mfr. Code	Mfr. Part No.
		Effective	Discont			
A68A8Q6075	151-0301-00			TRANSISTOR, SIG: BIPOLAR, PNP; 60V, 600MA, 200MHZ ,AMPLIFIER; 2N2907A, TO-18	80009	151-0301-00
A68A8Q7060	151-0301-00			TRANSISTOR, SIG: BIPOLAR, PNP; 60V, 600MA, 200MHZ ,AMPLIFIER; 2N2907A, TO-18	80009	151-0301-00
A68A8Q8035	151-0301-00			TRANSISTOR, SIG: BIPOLAR, PNP; 60V, 600MA, 200MHZ ,AMPLIFIER; 2N2907A, TO-18	80009	151-0301-00
A68A8Q8050	151-0301-00			TRANSISTOR, SIG: BIPOLAR, PNP; 60V, 600MA, 200MHZ ,AMPLIFIER; 2N2907A, TO-18	80009	151-0301-00
A68A8R700	315-0822-00			RES, FXD, FILM: 8.2K OHM, 5%, 0.25W (OPTION 07 ONLY)	80009	315-0822-00
A68A8R701	315-0822-00			RES, FXD, FILM: 8.2K OHM, 5%, 0.25W (OPTION 07 ONLY)	80009	315-0822-00
A68A8R1033	315-0121-00			RES, FXD, FILM: 120 OHM, 5%, 0.25W	80009	315-0121-00
A68A8R1035	315-0332-00			RES, FXD, FILM: 3.3K OHM, 5%, 0.25W	80009	315-0332-00
A68A8R1050	315-0332-00			RES, FXD, FILM: 3.3K OHM, 5%, 0.25W	80009	315-0332-00
A68A8R1055	315-0121-00			RES, FXD, FILM: 120 OHM, 5%, 0.25W	80009	315-0121-00
A68A8R1062	315-0103-00			RES, FXD, FILM: 10K OHM, 5%, 0.25W	80009	315-0103-00
A68A8R1064	321-0713-00			RES, FXD, FILM: 30 OHM, 1%, 0.125W, TC=TO	80009	321-0713-00
A68A8R1065	311-0622-00			RES, VAR, NONW: TRMR, 100 OHM, 0.5W	80009	311-0622-00
A68A8R1066	321-0032-00			RES, FXD, FILM: 21.0 OHM, 1%, 0.125W, TC=TO	80009	321-0032-00
A68A8R2014	315-0331-00			RES, FXD, FILM: 330 OHM, 5%, 0.25W	80009	315-0331-00
A68A8R2015	315-0331-00			RES, FXD, FILM: 330 OHM, 5%, 0.25W	80009	315-0331-00
A68A8R2016	315-0121-00			RES, FXD, FILM: 120 OHM, 5%, 0.25W	80009	315-0121-00
A68A8R2020	315-0332-00			RES, FXD, FILM: 3.3K OHM, 5%, 0.25W	80009	315-0332-00
A68A8R2025	315-0121-00			RES, FXD, FILM: 120 OHM, 5%, 0.25W	80009	315-0121-00
A68A8R2026	315-0332-00			RES, FXD, FILM: 3.3K OHM, 5%, 0.25W	80009	315-0332-00
A68A8R2030	315-0103-00			RES, FXD, FILM: 10K OHM, 5%, 0.25W	80009	315-0103-00
A68A8R2034	315-0103-00			RES, FXD, FILM: 10K OHM, 5%, 0.25W	80009	315-0103-00
A68A8R2037	315-0103-00			RES, FXD, FILM: 10K OHM, 5%, 0.25W	80009	315-0103-00
A68A8R2040	315-0332-00			RES, FXD, FILM: 3.3K OHM, 5%, 0.25W	80009	315-0332-00
A68A8R2043	315-0121-00			RES, FXD, FILM: 120 OHM, 5%, 0.25W	80009	315-0121-00
A68A8R2044	315-0103-00			RES, FXD, FILM: 10K OHM, 5%, 0.25W	80009	315-0103-00
A68A8R2045	315-0103-00			RES, FXD, FILM: 10K OHM, 5%, 0.25W	80009	315-0103-00
A68A8R2047	321-0054-00			RES, FXD, FILM: 35.7 OHM, 0.5%, 0.125W, TC=TO MI	80009	321-0054-00
A68A8R2048	321-0114-00			RES, FXD, FILM: 150 OHM, 1%, 0.125 W, TC=TO	80009	321-0114-00
A68A8R2049	321-0114-00			RES, FXD, FILM: 150 OHM, 1%, 0.125 W, TC=TO	80009	321-0114-00
A68A8R2059	315-0103-00			RES, FXD, FILM: 10K OHM, 5%, 0.25W	80009	315-0103-00
A68A8R2067	321-0114-00			RES, FXD, FILM: 150 OHM, 1%, 0.125 W, TC=TO	80009	321-0114-00
A68A8R3014	321-0001-00	B010100	B010181	RES, FXD, FILM: 10 OHM, 1%, 0.125W, TC=TO	75042	CEATO-10R00F
A68A8R3014	321-0054-00	B010182		RES, FXD, FILM: 35.7 OHM, 0.5%, 0.125W, TC=TO MI	80009	321-0054-00
A68A8R3015	311-0622-00			RES, VAR, NONW: TRMR, 100 OHM, 0.5W	80009	311-0622-00
A68A8R3019	321-0066-00	B010100	B010181	RES, FXD, FILM: 47.5 OHM, 0.5%, 0.125W, TC=TO	80009	321-0066-00
A68A8R3019	321-0032-00	B010182		RES, FXD, FILM: 21.0 OHM, 1%, 0.125W, TC=TO	80009	321-0032-00
A68A8R3022	315-0103-00			RES, FXD, FILM: 10K OHM, 5%, 0.25W	80009	315-0103-00
A68A8R3024	315-0103-00			RES, FXD, FILM: 10K OHM, 5%, 0.25W	80009	315-0103-00
A68A8R3028	315-0103-00			RES, FXD, FILM: 10K OHM, 5%, 0.25W	80009	315-0103-00
A68A8R3029	311-0622-00			RES, VAR, NONW: TRMR, 100 OHM, 0.5W	80009	311-0622-00
A68A8R3033	311-0622-00			RES, VAR, NONW: TRMR, 100 OHM, 0.5W	80009	311-0622-00
A68A8R3035	321-0713-00			RES, FXD, FILM: 30 OHM, 1%, 0.125W, TC=TO	80009	321-0713-00
A68A8R3036	321-0114-00			RES, FXD, FILM: 150 OHM, 1%, 0.125 W, TC=TO	80009	321-0114-00
A68A8R3037	321-0032-00			RES, FXD, FILM: 21.0 OHM, 1%, 0.125W, TC=TO	80009	321-0032-00
A68A8R4019	321-0114-00			RES, FXD, FILM: 150 OHM, 1%, 0.125 W, TC=TO	80009	321-0114-00
A68A8R4025	311-0633-00			RES, VAR, NONW: TRMR, 5K OHM, 0.5W	32997	3329H-L58-502
A68A8R4026	321-0001-00			RES, FXD, FILM: 10 OHM, 1%, 0.125W, TC=TO	75042	CEATO-10R00F
A68A8R4029	321-0178-00			RES, FXD, FILM: 698 OHM, 1%, 0.125W, TC=TO	07716	CEAD698R0F
A68A8R4030	321-0713-00			RES, FXD, FILM: 30 OHM, 1%, 0.125W, TC=TO	80009	321-0713-00
A68A8R4033	321-0032-00			RES, FXD, FILM: 21.0 OHM, 1%, 0.125W, TC=TO	80009	321-0032-00
A68A8R4034	321-0114-00			RES, FXD, FILM: 150 OHM, 1%, 0.125 W, TC=TO	80009	321-0114-00

Replaceable Electrical Parts
494A/494AP Service Vol.2

Component No.	Tektronix		Serial/Assembly No.	Name & Description	Mfr. Code	Mfr. Part No.
	Part No.	Effective Dscnt				
A68A8R5074	315-0103-00			RES,FXD,FILM:10K OHM,5%,0.25W	80009	315-0103-00
A68A8R5075	315-0103-00			RES,FXD,FILM:10K OHM,5%,0.25W	80009	315-0103-00
A68A8R6040	321-0097-00			RES,FXD,FILM:100 OHM,1%,0.125W,TC=TO	91637	CMF55116G100ROF
A68A8R6060	315-0332-00			RES,FXD,FILM:3.3K OHM,5%,0.25W	80009	315-0332-00
A68A8R6061	315-0121-00			RES,FXD,FILM:120 OHM,5%,0.25W	80009	315-0121-00
A68A8R6065	315-0103-00			RES,FXD,FILM:10K OHM,5%,0.25W	80009	315-0103-00
A68A8R6066	315-0103-00			RES,FXD,FILM:10K OHM,5%,0.25W	80009	315-0103-00
A68A8R6070	315-0332-00			RES,FXD,FILM:3.3K OHM,5%,0.25W	80009	315-0332-00
A68A8R6075	315-0121-00			RES,FXD,FILM:120 OHM,5%,0.25W	80009	315-0121-00
A68A8R7060	315-0332-00			RES,FXD,FILM:3.3K OHM,5%,0.25W	80009	315-0332-00
A68A8R7061	315-0103-00			RES,FXD,FILM:10K OHM,5%,0.25W	80009	315-0103-00
A68A8R7062	315-0121-00			RES,FXD,FILM:120 OHM,5%,0.25W	80009	315-0121-00
A68A8R7063	315-0103-00			RES,FXD,FILM:10K OHM,5%,0.25W	80009	315-0103-00
A68A8R8010	307-0106-00			RES,FXD,CMPSPN:4.7 OHM,5%,0.25W	01121	CB4765
A68A8R8026	315-0332-00			RES,FXD,FILM:3.3K OHM,5%,0.25W	80009	315-0332-00
A68A8R8027	315-0121-00			RES,FXD,FILM:120 OHM,5%,0.25W	80009	315-0121-00
A68A8R8030	315-0103-00			RES,FXD,FILM:10K OHM,5%,0.25W	80009	315-0103-00
A68A8R8035	315-0103-00			RES,FXD,FILM:10K OHM,5%,0.25W	80009	315-0103-00
A68A8R8047	315-0121-00			RES,FXD,FILM:120 OHM,5%,0.25W	80009	315-0121-00
A68A8R8048	315-0332-00			RES,FXD,FILM:3.3K OHM,5%,0.25W	80009	315-0332-00
A68A8R8050	315-0103-00			RES,FXD,FILM:10K OHM,5%,0.25W	80009	315-0103-00
A68A8R8055	315-0103-00			RES,FXD,FILM:10K OHM,5%,0.25W	80009	315-0103-00
A68A8R8070	304-0681-00			RES,FXD,CMPSPN:680 OHM,10%,1W	80009	304-0681-00
A68A8S4050	260-2031-00			SWITCH,ROCKER:(7)SPST,30VDC,125MA	81073	765B07S
A68A8T4040	120-1237-00			TRANSFORMER,RF:TOROID	80009	120-1237-00
A68A8T5047	120-1338-00			TRANSFORMER,RF:TOROID	80009	120-1338-00
A68A8T7042	120-1237-00			TRANSFORMER,RF:TOROID	80009	120-1237-00
A68A8T7050	120-1338-00			TRANSFORMER,RF:TOROID	80009	120-1338-00
A68A8U3070	156-1235-00			IC,DIGITAL:LS TTL,DEMUX/DECODER:BCD-TO-DECIMAL DECODER/DRIVER;74LS145,DIP16.3,TUBE	80009	156-1235-00
A68A8W3013	131-0566-00			BUS,CONDUCTOR:DUMMY RES,0.094 OD X 0.225 L	80009	131-0566-00
A68A9	670-9778-00			CIRCUIT BD ASSY:POST VR AMPLIFIER	80009	670-9778-00
A68A9C1010	283-5025-00			CAP,FXD,CER DI:220PF,5%,50V	80009	283-5025-00
A68A9C1011	283-5027-00			CAP,FXD,CER DI:470PF,5%,50V	54583	
A68A9C1012	283-5027-00			CAP,FXD,CER DI:470PF,5%,50V	54583	
A68A9C1020	283-5027-00			CAP,FXD,CER DI:470PF,5%,50V	54583	
A68A9C1021	283-5025-00			CAP,FXD,CER DI:220PF,5%,50V	80009	283-5025-00
A68A9C1022	283-5026-00			CAP,FXD,CER DI:390PF,5%,50V	54583	
A68A9C1023	283-5004-00			CAP,FXD,CER DI:0.1UF,10%,25V	80009	283-5004-00
A68A9C1024	283-5025-00			CAP,FXD,CER DI:220PF,5%,50V	80009	283-5025-00
A68A9C1030	283-5026-00			CAP,FXD,CER DI:390PF,5%,50V	54583	
A68A9C1031	283-5025-00			CAP,FXD,CER DI:220PF,5%,50V	80009	283-5025-00
A68A9C1032	283-5004-00			CAP,FXD,CER DI:0.1UF,10%,25V	80009	283-5004-00
A68A9C1033	283-5004-00			CAP,FXD,CER DI:0.1UF,10%,25V	80009	283-5004-00
A68A9C1034	283-5004-00			CAP,FXD,CER DI:0.1UF,10%,25V	80009	283-5004-00
A68A9C1040	283-5003-00			CAP,FXD,CER DI:0.01UF,10%,50V	80009	283-5003-00
A68A9C1041	283-5004-00			CAP,FXD,CER DI:0.1UF,10%,25V	80009	283-5004-00
A68A9L1010	108-1367-00			COIL,RF:FXD,870NH,5%	TK1345	108-1367-00
A68A9L1012	108-1366-00			COIL,RF:FXD,1.047UH,5%,TOROID	TK1345	108-1366-00
A68A9L1020	108-1366-00			COIL,RF:FXD,1.047UH,5%,TOROID	TK1345	108-1366-00
A68A9L1021	108-1367-00			COIL,RF:FXD,870NH,5%	TK1345	108-1367-00
A68A9L1022	108-1368-00			COIL,RF:FXD,540NH,5%	TK1345	108-1368-00
A68A9L1023	108-1369-00			COIL,RF:FXD,465NH,5%	TK1345	108-1369-00
A68A9L1030	108-1368-00			COIL,RF:FXD,540NH,5%	TK1345	108-1368-00
A68A9Q1030	151-0446-00			TRANSISTOR,SIG:BIPOLAR,NPN;30V VCEO,55V VCB 0.400MA,500MHZ,AMPLIFIER;2N3866,TO-39	80009	151-0446-00
A68A9Q1040	151-0411-00			TRANSISTOR,SIG:BIPOLAR,NPN;30V,400MA,1.2GHZ ,AMPLIFIER;2N5943,TO-39	80009	151-0411-00

Replaceable Electrical Parts
494A/494AP Service Vol.2

Component No.	Tektronix Part No.	Serial/Assembly No. Effective	Discont	Name & Description	Mfr. Code	Mfr. Part No.
A68A9R1020	321-5015-00			RES, FXD, FILM: 562 OHM, 1%, 0.125W	80009	321-5015-00
A68A9R1030	311-0622-00			RES, VAR, NONWM: TRMR, 100 OHM, 0.5W	80009	311-0622-00
A68A9R1031	321-5046-00			RES, FXD, FILM: 82.5 OHM, 1%, 0.125W	80009	321-5046-00
A68A9R1032	321-5006-00			RES, FXD, FILM: 100 OHM, 1%, 0.125W	80009	321-5006-00
A68A9R1033	321-5006-00			RES, FXD, FILM: 100 OHM, 1%, 0.125W	80009	321-5006-00
A68A9R1034	321-5004-00			RES, FXD, FILM: 22.1 OHM, 1%, 0.125W	80009	321-5004-00
A68A9R1035	321-5008-00			RES, FXD, FILM: 150 OHM, 1%, 0.125W	80009	321-5008-00
A68A9R1036	321-5004-00			RES, FXD, FILM: 22.1 OHM, 1%, 0.125W	80009	321-5004-00
A68A9R1037	321-5012-00			RES, FXD, FILM: 332 OHM, 1%, 0.125W	80009	321-5012-00
A68A9R1038	321-5012-00			RES, FXD, FILM: 332 OHM, 1%, 0.125W	80009	321-5012-00
A68A9R1040	321-5010-00			RES, FXD, FILM: 221 OHM, 1%, 0.125W	80009	321-5010-00
A68A9R1041	321-5015-00			RES, FXD, FILM: 562 OHM, 1%, 0.125W	80009	321-5015-00
A68A9R1042	321-0001-00			RES, FXD, FILM: 10 OHM, 1%, 0.125W, TC=TO	75042	CEAT0-10R00F
A68A9R1043	321-5010-00			RES, FXD, FILM: 221 OHM, 1%, 0.125W	80009	321-5010-00
A68A9T1020	120-0459-00			XFMR, TOROID:	80009	120-0459-00
A68A9T1040	120-1237-00			TRANSFORMER, RF: TOROID	80009	120-1237-00
A68A9T1041	120-0902-00			XFMR, TOROID:	80009	120-0902-00
A69	119-2502-00	B010100	B010181	FILTER, DUAL BW: 100HZ	80009	119-2502-00
A69	119-2502-01	B010182		FILTER, DUAL BW: 100HZ	80009	119-2502-01
A69C690	281-0825-00			CAP, FXD, CER DI: 0.005UF, +100-0%, 100V	33095	51-726-008
A69C691	281-0825-00			CAP, FXD, CER DI: 0.005UF, +100-0%, 100V	33095	51-726-008
A69P696	131-0156-00			CONN, RF PLUG:	24931	32JR104-3
A69W696	174-0705-00			CABLE ASSY, RF: 50 OHM COAX, 11.0 L	80009	174-0705-00
A69Y1040	158-0331-00			XTAL UNIT, QTZ: 19.5MHZ, 0.001%, -20 TO +60C, PARALLE	75378	158-0331-00
A69Y2020	119-0969-00			FILTER, BANDPASS: XTAL, 4 POLE ML (MATCHED WITH A69Y2025)	75378	965-0160
A69Y2025	119-0969-00			FILTER, BANDPASS: XTAL, 4 POLE ML (MATCHED WITH A69Y2020)	75378	965-0160
A69A1	670-9948-00	B010100	B010181	CIRCUIT BD ASSY: 1ST MIXER	80009	670-9948-00
A69A1	670-9948-02	B010182		CIRCUIT BD ASSY: 1ST MIXER	80009	670-9948-02
A69A1C1111	283-5004-00			CAP, FXD, CER DI: 0.1UF, 10%, 25V	80009	283-5004-00
A69A1C1127	283-5003-00			CAP, FXD, CER DI: 0.01UF, 10%, 50V	80009	283-5003-00
A69A1C2121	283-5003-00			CAP, FXD, CER DI: 0.01UF, 10%, 50V	80009	283-5003-00
A69A1C2125	283-5004-00			CAP, FXD, CER DI: 0.1UF, 10%, 25V	80009	283-5004-00
A69A1C3121	283-5004-00			CAP, FXD, CER DI: 0.1UF, 10%, 25V	80009	283-5004-00
A69A1C3125	283-5004-00			CAP, FXD, CER DI: 0.1UF, 10%, 25V	80009	283-5004-00
A69A1C3129	283-5004-00			CAP, FXD, CER DI: 0.1UF, 10%, 25V	80009	283-5004-00
A69A1C4010	290-5001-00			CAP, FXD, ELCLTL: 10UF, 20%, 16V	TK0900	ALCHIP-S16V10UF
A69A1C4011	290-5001-00			CAP, FXD, ELCLTL: 10UF, 20%, 16V	TK0900	ALCHIP-S16V10UF
A69A1C4111	283-5004-00			CAP, FXD, CER DI: 0.1UF, 10%, 25V	80009	283-5004-00
A69A1C4113	283-5004-00			CAP, FXD, CER DI: 0.1UF, 10%, 25V	80009	283-5004-00
A69A1C4115	283-5004-00			CAP, FXD, CER DI: 0.1UF, 10%, 25V	80009	283-5004-00
A69A1C5020	283-5003-00			CAP, FXD, CER DI: 0.01UF, 10%, 50V	80009	283-5003-00
A69A1C5021	283-5003-00			CAP, FXD, CER DI: 0.01UF, 10%, 50V	80009	283-5003-00
A69A1C5129	283-5001-00			CAP, FXD, CER DI: 100PF, 5%, 50V	80009	283-5001-00
A69A1P697	131-0938-00			CONN, RF JACK: :SMB/PNL, :MALE, STR, 50 OHM, 0.25 HEX, 2.0 L 0.025 DIA TAIL, 10-32 THD, REAR MT	24931	32JR125-1
A69A1Q5010	151-5001-00			TRANSISTOR, SIG: BIPOLAR, NPN; 40V, 200MA, 300MHZ	80009	151-5001-00
A69A1Q5015	151-5005-00			AMPLIFIER; MMBT3904L, TO-236/SOT-23, 8MM T&R	04713	BCX69T1
A69A1Q5020	151-5004-00			TRANSISTOR, SIG: BIPOLAR, NPN; 20V, 1.0A, 65MHZ, A	04713	BCX68
A69A1Q5025	151-5004-00			AMPLIFIER; BCX68/BC868, SOT-89, 12MM T/R	04713	BCX66
A69A1R1111	321-5010-00			RES, FXD, FILM: 221 OHM, 1%, 0.125W	80009	321-5010-00
A69A1R2129	321-5030-00			RES, FXD, FILM: 10.0K, 1%, 0.125W	80009	321-5030-00

Replaceable Electrical Parts
494A/494AP Service Vol.2

Component No.	Tektronix Part No.	Serial/Assembly No. Effective	Discort	Name & Description	Mfr. Code	Mfr. Part No.
A69AIR3010	311-1228-00			RES,VAR, NONW: TRMR, 10K OHM, 0.5W	80009	311-1228-00
A69AIR3111	321-5014-00	B010100	B010181	RES,FXD, FILM: 475 OHM, 1%, 0.125W	80009	321-5014-00
A69AIR3111	321-5012-00	B010182		RES,FXD, FILM: 332 OHM, 1%, 0.125W	80009	321-5012-00
A69AIR3115	321-5000-00	B010100	B010181	RES,FXD, FILM: 10 OHM, 1%, 0.125W	57668	MCR18EZHFW10E
A69AIR3115	321-5003-00	B010182		RES,FXD, FILM: 18.2 OHM, 1%, 0.125W	57668	MCR18EZHFW 18E2
A69AIR3117	321-5014-00	B010100	B010181	RES,FXD, FILM: 475 OHM, 1%, 0.125W	80009	321-5014-00
A69AIR3117	321-5012-00	B010182		RES,FXD, FILM: 332 OHM, 1%, 0.125W	80009	321-5012-00
A69AIR3121	321-5000-00			RES,FXD, FILM: 10 OHM, 1%, 0.125W	57668	MCR18EZHFW10E
A69AIR4111	321-5022-00			RES,FXD, FILM: 2.21K, 1%, 0.125W	80009	321-5022-00
A69AIR4121	321-5030-00			RES,FXD, FILM: 10.0K, 1%, 0.125W	80009	321-5030-00
A69AIR4122	321-5015-00			RES,FXD, FILM: 562 OHM, 1%, 0.125W	80009	321-5015-00
A69AIR4123	321-5030-00			RES,FXD, FILM: 10.0K, 1%, 0.125W	80009	321-5030-00
A69AIR4124	321-5015-00			RES,FXD, FILM: 562 OHM, 1%, 0.125W	80009	321-5015-00
A69AIR4125	321-5000-00			RES,FXD, FILM: 10 OHM, 1%, 0.125W	57668	MCR18EZHFW10E
A69AIR4127	321-5016-00			RES,FXD, FILM: 681 OHM, 1%, 0.125W	01121	BCK6810FT
A69AIR5010	321-5023-00			RES,FXD, FILM: 2.74K, 1%, 0.125W	80009	321-5023-00
A69AIR5111	321-5009-00			RES,FXD, FILM: 182 OHM, 1%, 0.125W	80009	321-5009-00
A69AIR5113	321-5009-00			RES,FXD, FILM: 182 OHM, 1%, 0.125W	80009	321-5009-00
A69AIR5115	321-5009-00			RES,FXD, FILM: 182 OHM, 1%, 0.125W	80009	321-5009-00
A69AIR5117	321-5010-00			RES,FXD, FILM: 221 OHM, 1%, 0.125W	80009	321-5010-00
A69AIR5121	321-5030-00			RES,FXD, FILM: 10.0K, 1%, 0.125W	80009	321-5030-00
A69AIR5123	321-5030-00			RES,FXD, FILM: 10.0K, 1%, 0.125W	80009	321-5030-00
A69AIR5125	321-5030-00			RES,FXD, FILM: 10.0K, 1%, 0.125W	80009	321-5030-00
A69AIR5127	321-5030-00			RES,FXD, FILM: 10.0K, 1%, 0.125W	80009	321-5030-00
A69AIT1011	120-1237-00			TRANSFORMER, RF: TOROID	80009	120-1237-00
A69AIT3025	120-1237-00			TRANSFORMER, RF: TOROID	80009	120-1237-00
A69AIT4020	120-1150-00			TRANSFORMER, RF: TOROID	80009	120-1150-00
A69AIT4025	120-1057-00			TRANSFORMER, RF: TOROID	80009	120-1057-00
A69AIU5010	156-5018-00			IC, LINEAR: BIPOLAR, OP-AMP; DUAL, SINGLE SUPPLY ; LM358D, SO8, 150, TUBE	80009	156-5018-00
A69AIU5020	156-5281-00			IC, LINEAR: DMOS, MISC; BALANCED MIXER; SI8901Y, S015, 150	80009	156-5281-00
A69A2	670-9949-00	B010100	B010181	CIRCUIT BD ASSY: BAND PASS FILTER	80009	670-9949-00
A69A2	670-9949-01	B010182		CIRCUIT BD ASSY: BAND PASS FILTER	80009	670-9949-01
A69A2C1061	283-5004-00			CAP, FXD, CER DI: 0.1UF, 10%, 25V	80009	283-5004-00
A69A2C1065	283-5004-00			CAP, FXD, CER DI: 0.1UF, 10%, 25V	80009	283-5004-00
A69A2C1066	283-5004-00			CAP, FXD, CER DI: 0.1UF, 10%, 25V	80009	283-5004-00
A69A2C1120	283-5000-00	B010100	B010181	CAP, FXD, CER DI: 10PF, 5%, 50V	80009	283-5000-00
A69A2C1120	283-5022-00	B010182		CAP, FXD, CER DI: 47PF, 5%, 50V	54583	
A69A2C1121	283-5001-00			CAP, FXD, CER DI: 100PF, 5%, 50V	80009	283-5001-00
A69A2C2061	283-5004-00			CAP, FXD, CER DI: 0.1UF, 10%, 25V	80009	283-5004-00
A69A2C2063	283-5004-00			CAP, FXD, CER DI: 0.1UF, 10%, 25V	80009	283-5004-00
A69A2C2067	283-5004-00			CAP, FXD, CER DI: 0.1UF, 10%, 25V	80009	283-5004-00
A69A2C2111	283-5004-00			CAP, FXD, CER DI: 0.1UF, 10%, 25V	80009	283-5004-00
A69A2C2122	283-5004-00			CAP, FXD, CER DI: 0.1UF, 10%, 25V	80009	283-5004-00
A69A2C2148	283-5004-00			CAP, FXD, CER DI: 0.1UF, 10%, 25V	80009	283-5004-00
A69A2C2150	283-5000-00	B010100	B010181	CAP, FXD, CER DI: 10PF, 5%, 50V	80009	283-5000-00
A69A2C2150	283-5022-00	B010182		CAP, FXD, CER DI: 47PF, 5%, 50V	54583	
A69A2C2162	283-5004-00			CAP, FXD, CER DI: 0.1UF, 10%, 25V	80009	283-5004-00
A69A2C3048	283-5004-00			CAP, FXD, CER DI: 0.1UF, 10%, 25V	80009	283-5004-00
A69A2C3062	283-5004-00			CAP, FXD, CER DI: 0.1UF, 10%, 25V	80009	283-5004-00
A69A2C3064	283-5004-00			CAP, FXD, CER DI: 0.1UF, 10%, 25V	80009	283-5004-00
A69A2C3066	283-5004-00			CAP, FXD, CER DI: 0.1UF, 10%, 25V	80009	283-5004-00
A69A2C3116	283-5004-00			CAP, FXD, CER DI: 0.1UF, 10%, 25V	80009	283-5004-00
A69A2C3118	283-5049-00			CAP, FXD, CER DI: 180PF, 5%, 50V	95275	VJ1206A181JXA
A69A2C3125	283-5004-00			CAP, FXD, CER DI: 0.1UF, 10%, 25V	80009	283-5004-00
A69A2C3128	283-5022-00			CAP, FXD, CER DI: 47PF, 5%, 50V	54583	
A69A2C3133	283-5004-00			CAP, FXD, CER DI: 0.1UF, 10%, 25V	80009	283-5004-00

Replaceable Electrical Parts
494A/494AP Service Vol.2

Component No.	Tektronix Part No.	Serial/Assembly No. Effective Dscort	Name & Description	Mfr. Code	Mfr. Part No.
A69A2C3146	283-5022-00		CAP, FXD, CER DI: 47PF, 5%, 50V	54583	
A69A2C3149	283-5001-00		CAP, FXD, CER DI: 100PF, 5%, 50V	80009	283-5001-00
A69A2C3152	283-5022-00		CAP, FXD, CER DI: 47PF, 5%, 50V	54583	
A69A2C4015	281-0204-00		CAP, VAR, PLASTIC: 2-22PF, 100V	19701	2807C00222MJ02
A69A2C4028	281-0205-00		CAP, VAR, PLASTIC: 5.5-65 PF, 100V	TK1727	2222-808-32659
A69A2C4032	283-5004-00		CAP, FXD, CER DI: 0.1UF, 10%, 25V	80009	283-5004-00
A69A2C4036	281-0205-00		CAP, VAR, PLASTIC: 5.5-65 PF, 100V	TK1727	2222-808-32659
A69A2C4038	283-5004-00		CAP, FXD, CER DI: 0.1UF, 10%, 25V	80009	283-5004-00
A69A2C4045	281-0204-00		CAP, VAR, PLASTIC: 2-22PF, 100V	19701	2807C00222MJ02
A69A2C4051	281-0205-00		CAP, VAR, PLASTIC: 5.5-65 PF, 100V	TK1727	2222-808-32659
A69A2C4059	283-5004-00		CAP, FXD, CER DI: 0.1UF, 10%, 25V	80009	283-5004-00
A69A2C4060	281-0204-00		CAP, VAR, PLASTIC: 2-22PF, 100V	19701	2807C00222MJ02
A69A2C4065	283-5004-00		CAP, FXD, CER DI: 0.1UF, 10%, 25V	80009	283-5004-00
A69A2C4068	283-5004-00		CAP, FXD, CER DI: 0.1UF, 10%, 25V	80009	283-5004-00
A69A2C4111	283-5004-00		CAP, FXD, CER DI: 0.1UF, 10%, 25V	80009	283-5004-00
A69A2C4115	283-5001-00		CAP, FXD, CER DI: 100PF, 5%, 50V	80009	283-5001-00
A69A2C4120	283-5004-00		CAP, FXD, CER DI: 0.1UF, 10%, 25V	80009	283-5004-00
A69A2C4133	283-5004-00		CAP, FXD, CER DI: 0.1UF, 10%, 25V	80009	283-5004-00
A69A2C4134	283-5004-00		CAP, FXD, CER DI: 0.1UF, 10%, 25V	80009	283-5004-00
A69A2C4142	283-5004-00		CAP, FXD, CER DI: 0.1UF, 10%, 25V	80009	283-5004-00
A69A2C4144	283-5004-00		CAP, FXD, CER DI: 0.1UF, 10%, 25V	80009	283-5004-00
A69A2C4146	283-5004-00		CAP, FXD, CER DI: 0.1UF, 10%, 25V	80009	283-5004-00
A69A2C4151	283-5004-00		CAP, FXD, CER DI: 0.1UF, 10%, 25V	80009	283-5004-00
A69A2C4156	283-5004-00		CAP, FXD, CER DI: 0.1UF, 10%, 25V	80009	283-5004-00
A69A2C4164	283-5004-00		CAP, FXD, CER DI: 0.1UF, 10%, 25V	80009	283-5004-00
A69A2CR3060	152-5000-00		SEMICON DVC, DI: SW, SI, 70V, COM CATHODE	80009	152-5000-00
A69A2Q1060	151-5002-00		TRANSISTOR, SIG: JFET, N-CH; 5V, 75MA, 60 OHM, SWI TCH; MMBF4392L, SOT-23, 8MM T&R	80009	151-5002-00
A69A2Q1065	151-5000-00		TRANSISTOR, SIG: BIPOLAR, PNP; 40V, 200MA, 250MHZ ,AMPLIFIER; MMBT3906L, TO-236/SOT-23, 8MM T&R	04713	MMBT3906LT1
A69A2Q2060	151-5004-00		TRANSISTOR, SIG: BIPOLAR, NPN; 20V, 1.0A, 65MHZ, A MPLIFIER; BCX68/BC868, SOT-89, 12MM T/R	04713	BCX68
A69A2Q2130	151-5001-00		TRANSISTOR, SIG: BIPOLAR, NPN; 40V, 200MA, 300MHZ ,AMPLIFIER; MMBT3904L, TO-236/SOT-23, 8MM T&R	80009	151-5001-00
A69A2Q2150	151-5001-00		TRANSISTOR, SIG: BIPOLAR, NPN; 40V, 200MA, 300MHZ ,AMPLIFIER; MMBT3904L, TO-236/SOT-23, 8MM T&R	80009	151-5001-00
A69A2Q3065	151-5001-00		TRANSISTOR, SIG: BIPOLAR, NPN; 40V, 200MA, 300MHZ ,AMPLIFIER; MMBT3904L, TO-236/SOT-23, 8MM T&R	80009	151-5001-00
A69A2Q3110	151-5001-00		TRANSISTOR, SIG: BIPOLAR, NPN; 40V, 200MA, 300MHZ ,AMPLIFIER; MMBT3904L, TO-236/SOT-23, 8MM T&R	80009	151-5001-00
A69A2Q3155	151-5002-00		TRANSISTOR, SIG: JFET, N-CH; 5V, 75MA, 60 OHM, SWI TCH; MMBF4392L, SOT-23, 8MM T&R	80009	151-5002-00
A69A2Q4060	151-5004-00		TRANSISTOR, SIG: BIPOLAR, NPN; 20V, 1.0A, 65MHZ, A MPLIFIER; BCX68/BC868, SOT-89, 12MM T/R	04713	BCX68
A69A2Q4110	151-5000-00		TRANSISTOR, SIG: BIPOLAR, PNP; 40V, 200MA, 250MHZ ,AMPLIFIER; MMBT3906L, TO-236/SOT-23, 8MM T&R	04713	MMBT3906LT1
A69A2Q4120	151-5002-00		TRANSISTOR, SIG: JFET, N-CH; 5V, 75MA, 60 OHM, SWI TCH; MMBF4392L, SOT-23, 8MM T&R	80009	151-5002-00
A69A2Q4125	151-5001-00		TRANSISTOR, SIG: BIPOLAR, NPN; 40V, 200MA, 300MHZ ,AMPLIFIER; MMBT3904L, TO-236/SOT-23, 8MM T&R	80009	151-5001-00
A69A2Q4130	151-5001-00		TRANSISTOR, SIG: BIPOLAR, NPN; 40V, 200MA, 300MHZ ,AMPLIFIER; MMBT3904L, TO-236/SOT-23, 8MM T&R	80009	151-5001-00
A69A2Q4140	151-5001-00		TRANSISTOR, SIG: BIPOLAR, NPN; 40V, 200MA, 300MHZ ,AMPLIFIER; MMBT3904L, TO-236/SOT-23, 8MM T&R	80009	151-5001-00
A69A2Q4145	151-5004-00		TRANSISTOR, SIG: BIPOLAR, NPN; 20V, 1.0A, 65MHZ, A MPLIFIER; BCX68/BC868, SOT-89, 12MM T/R	04713	BCX68
A69A2Q4150	151-5000-00		TRANSISTOR, SIG: BIPOLAR, PNP; 40V, 200MA, 250MHZ ,AMPLIFIER; MMBT3906L, TO-236/SOT-23, 8MM T&R	04713	MMBT3906LT1

Replaceable Electrical Parts
494A/494AP Service Vol.2

Component No.	Tektronix Part No.	Serial/Assembly No. Effective	Dscont	Name & Description	Mfr. Code	Mfr. Part No.
A69A2Q4155	151-5001-00			TRANSISTOR, SIG: BIPOLAR, NPN; 40V, 200MA, 300MHZ, AMPLIFIER; MMBT3904L, TO-236/SOT-23, 8MM T&R	80009	151-5001-00
A69A2R1060	321-5016-00	B010100	B010181	RES, FXD, FILM: 681 OHM, 1%, 0.125W	01121	BCK6810FT
A69A2R1060	321-5019-00	B010182		RES, FXD, FILM: 1.21K, 1%, 0.125W	80009	321-5019-00
A69A2R1061	321-5024-00			RES, FXD, FILM: 3.32K, 1%, 0.125W	80009	321-5024-00
A69A2R1065	321-5013-00			RES, FXD, FILM: 392 OHM, 1%, 0.125W	80009	321-5013-00
A69A2R1067	321-5006-00			RES, FXD, FILM: 100 OHM, 1%, 0.125W	80009	321-5006-00
A69A2R1068	321-5006-00			RES, FXD, FILM: 100 OHM, 1%, 0.125W	80009	321-5006-00
A69A2R1121	321-5036-00	B010100	B010181	RES, FXD, FILM: 33.2K, 1%, 0.125W	80009	321-5036-00
A69A2R1121	321-5036-00	B010182		RES, FXD, FILM: 33.2K, 1%, 0.125W	80009	321-5036-00
A69A2R2062	321-5008-00			RES, FXD, FILM: 150 OHM, 1%, 0.125W	80009	321-5008-00
A69A2R2064	321-5043-00			RES, FXD, FILM: 47.5 OHM, 1%, 0.125W	80009	321-5043-00
A69A2R2067	321-5018-00			RES, FXD, FILM: 1.00K, 1%, 0.125W	80009	321-5018-00
A69A2R2068	321-5017-00			RES, FXD, FILM: 825 OHM, 1%, 0.125W	80009	321-5017-00
A69A2R2111	321-5043-00			RES, FXD, FILM: 47.5 OHM, 1%, 0.125W	80009	321-5043-00
A69A2R2121	321-5018-00	B010100	B010181	RES, FXD, FILM: 1.00K, 1%, 0.125W	80009	321-5018-00
A69A2R2121	321-5019-00	B010182		RES, FXD, FILM: 1.21K, 1%, 0.125W	80009	321-5019-00
A69A2R2123	321-5048-00			RES, FXD, FILM: 332K, 1%, 0.125W	80009	321-5048-00
A69A2R2125	321-5030-00			RES, FXD, FILM: 10.0K, 1%, 0.125W	80009	321-5030-00
A69A2R2148	321-5006-00			RES, FXD, FILM: 100 OHM, 1%, 0.125W	80009	321-5006-00
A69A2R2149	321-5036-00	B010100	B010181	RES, FXD, FILM: 33.2K, 1%, 0.125W	80009	321-5036-00
A69A2R2149	321-5028-00	B010182		RES, FXD, FILM: 6.81K, 1%, 0.125W	80009	321-5028-00
A69A2R2155	321-5048-00			RES, FXD, FILM: 332K, 1%, 0.125W	80009	321-5048-00
A69A2R2156	321-5030-00			RES, FXD, FILM: 10.0K, 1%, 0.125W	80009	321-5030-00
A69A2R2160	321-5014-00			RES, FXD, FILM: 475 OHM, 1%, 0.125W	80009	321-5014-00
A69A2R2161	321-5018-00			RES, FXD, FILM: 1.00K, 1%, 0.125W	80009	321-5018-00
A69A2R2162	321-5000-00			RES, FXD, FILM: 10 OHM, 1%, 0.125W	57668	MCR1#EZHF10E
A69A2R2164	321-5014-00			RES, FXD, FILM: 475 OHM, 1%, 0.125W	80009	321-5014-00
A69A2R2166	321-5026-00			RES, FXD, FILM: 4.75K, 1%, 0.125W	80009	321-5026-00
A69A2R3031	321-5042-00			RES, FXD, FILM: 39.2 OHM, 1%, 0.125W	80009	321-5042-00
A69A2R3060	321-5042-00			RES, FXD, FILM: 39.2 OHM, 1%, 0.125W	80009	321-5042-00
A69A2R3061	321-5011-00			RES, FXD, FILM: 274 OHM, 1%, 0.125W	80009	321-5011-00
A69A2R3062	321-5006-00			RES, FXD, FILM: 100 OHM, 1%, 0.125W	80009	321-5006-00
A69A2R3064	321-5024-00			RES, FXD, FILM: 3.32K, 1%, 0.125W	80009	321-5024-00
A69A2R3066	321-5011-00			RES, FXD, FILM: 274 OHM, 1%, 0.125W	80009	321-5011-00
A69A2R3067	321-5018-00			RES, FXD, FILM: 1.00K, 1%, 0.125W	80009	321-5018-00
A69A2R3110	321-5008-00			RES, FXD, FILM: 150 OHM, 1%, 0.125W	80009	321-5008-00
A69A2R3112	321-5006-00			RES, FXD, FILM: 100 OHM, 1%, 0.125W	80009	321-5006-00
A69A2R3114	321-5030-00			RES, FXD, FILM: 10.0K, 1%, 0.125W	80009	321-5030-00
A69A2R3116	321-5026-00			RES, FXD, FILM: 4.75K, 1%, 0.125W	80009	321-5026-00
A69A2R3118	321-5021-00			RES, FXD, FILM: 1.82K, 1%, 0.125W	80009	321-5021-00
A69A2R3125	321-5006-00			RES, FXD, FILM: 100 OHM, 1%, 0.125W	80009	321-5006-00
A69A2R3126	321-5013-00			RES, FXD, FILM: 392 OHM, 1%, 0.125W	80009	321-5013-00
A69A2R3127	321-5026-00			RES, FXD, FILM: 4.75K, 1%, 0.125W	80009	321-5026-00
A69A2R3131	321-5014-00			RES, FXD, FILM: 475 OHM, 1%, 0.125W	80009	321-5014-00
A69A2R3133	321-5048-00			RES, FXD, FILM: 332K, 1%, 0.125W	80009	321-5048-00
A69A2R3135	321-5017-00			RES, FXD, FILM: 825 OHM, 1%, 0.125W	80009	321-5017-00
A69A2R3136	321-5018-00			RES, FXD, FILM: 1.00K, 1%, 0.125W	80009	321-5018-00
A69A2R3140	321-5031-00	B010100	B010181	RES, FXD, FILM: 12.1K, 1%, 0.125W	80009	321-5031-00
A69A2R3140	321-5030-00	B010182		RES, FXD, FILM: 10.0K, 1%, 0.125W	80009	321-5030-00
A69A2R3156	321-5017-00			RES, FXD, FILM: 825 OHM, 1%, 0.125W	80009	321-5017-00
A69A2R3160	321-5018-00			RES, FXD, FILM: 1.00K, 1%, 0.125W	80009	321-5018-00
A69A2R3162	321-5015-00	B010100	B010181	RES, FXD, FILM: 562 OHM, 1%, 0.125W	80009	321-5015-00
A69A2R3162	321-5019-00	B010182		RES, FXD, FILM: 1.21K, 1%, 0.125W	80009	321-5019-00
A69A2R4026	321-5026-00			RES, FXD, FILM: 4.75K, 1%, 0.125W	80009	321-5026-00
A69A2R4027	321-5016-00	B010100	B010181	RES, FXD, FILM: 681 OHM, 1%, 0.125W	01121	BCK6810FT
A69A2R4027	321-5019-00	B010182		RES, FXD, FILM: 1.21K, 1%, 0.125W	80009	321-5019-00
A69A2R4029	321-5017-00			RES, FXD, FILM: 825 OHM, 1%, 0.125W	80009	321-5017-00

Replaceable Electrical Parts
494A/494AP Service Vol.2

Component No.	Tektronix Part No.	Serial/Assembly No. Effective Dscont	Name & Description	Mfr. Code	Mfr. Part No.
A69A2R4034	321-5018-00		RES, FXD, FILM: 1.00K, 1%, 0.125W	80009	321-5018-00
A69A2R4058	321-5027-00		RES, FXD, FILM: 5.62K, 1%, 0.125W	80009	321-5027-00
A69A2R4059	321-5024-00		RES, FXD, FILM: 3.32K, 1%, 0.125W	80009	321-5024-00
A69A2R4063	321-5042-00		RES, FXD, FILM: 39.2 OHM, 1%, 0.125W	80009	321-5042-00
A69A2R4064	321-5018-00		RES, FXD, FILM: 1.00K, 1%, 0.125W	80009	321-5018-00
A69A2R4065	321-5017-00		RES, FXD, FILM: 825 OHM, 1%, 0.125W	80009	321-5017-00
A69A2R4115	321-5048-00		RES, FXD, FILM: 332K, 1%, 0.125W	80009	321-5048-00
A69A2R4119	321-5048-00		RES, FXD, FILM: 332K, 1%, 0.125W	80009	321-5048-00
A69A2R4121	321-5018-00		RES, FXD, FILM: 1.00K, 1%, 0.125W	80009	321-5018-00
A69A2R4122	321-5031-00		RES, FXD, FILM: 12.1K, 1%, 0.125W	80009	321-5031-00
A69A2R4123	321-5017-00		RES, FXD, FILM: 825 OHM, 1%, 0.125W	80009	321-5017-00
A69A2R4125	321-5030-00		RES, FXD, FILM: 10.0K, 1%, 0.125W	80009	321-5030-00
A69A2R4126	321-5030-00		RES, FXD, FILM: 10.0K, 1%, 0.125W	80009	321-5030-00
A69A2R4127	321-5026-00		RES, FXD, FILM: 4.75K, 1%, 0.125W	80009	321-5026-00
A69A2R4131	321-5026-00		RES, FXD, FILM: 4.75K, 1%, 0.125W	80009	321-5026-00
A69A2R4132	321-5024-00		RES, FXD, FILM: 3.32K, 1%, 0.125W	80009	321-5024-00
A69A2R4135	321-5011-00		RES, FXD, FILM: 274 OHM, 1%, 0.125W	80009	321-5011-00
A69A2R4136	321-5011-00		RES, FXD, FILM: 274 OHM, 1%, 0.125W	80009	321-5011-00
A69A2R4137	321-5006-00		RES, FXD, FILM: 100 OHM, 1%, 0.125W	80009	321-5006-00
A69A2R4143	321-5004-00		RES, FXD, FILM: 22.1 OHM, 1%, 0.125W	80009	321-5004-00
A69A2R4144	321-5008-00		RES, FXD, FILM: 150 OHM, 1%, 0.125W	80009	321-5008-00
A69A2R4145	321-5006-00		RES, FXD, FILM: 100 OHM, 1%, 0.125W	80009	321-5006-00
A69A2R4149	321-5024-00		RES, FXD, FILM: 3.32K, 1%, 0.125W	80009	321-5024-00
A69A2R4152	321-5013-00		RES, FXD, FILM: 392 OHM, 1%, 0.125W	80009	321-5013-00
A69A2R4153	321-5048-00		RES, FXD, FILM: 332K, 1%, 0.125W	80009	321-5048-00
A69A2R4161	321-5030-00		RES, FXD, FILM: 10.0K, 1%, 0.125W	80009	321-5030-00
A69A2R4163	321-5031-00	B010100	RES, FXD, FILM: 12.1K, 1%, 0.125W	80009	321-5031-00
A69A2R4163	321-5030-00	B010182	RES, FXD, FILM: 10.0K, 1%, 0.125W	80009	321-5030-00
A69A2T3016	120-1632-00		TRANSFORMER, RF: TOROID	80009	120-1632-00
A69A2Y2020	158-0328-00		XTAL UNIT SET, Q:(3)MATCHED (MATCHED WITH A69A2Y2030, A69A2Y2050)	80009	158-0328-00
A69A2Y2030	158-0328-00		XTAL UNIT SET, Q:(3)MATCHED (MATCHED WITH A69A2Y2020, A69A2Y2050)	80009	158-0328-00
A69A2Y2050	158-0328-00		XTAL UNIT SET, Q:(3)MATCHED (MATCHED WITH A69A2Y2020, A69A2Y2030)	80009	158-0328-00
A69A2A1	670-6067-00		CIRCUIT BD ASSY: CRYSTAL HOLDER	80009	670-6067-00
A69A2A2	670-6067-00		CIRCUIT BD ASSY: CRYSTAL HOLDER	80009	670-6067-00
A69A2A3	670-6067-00		CIRCUIT BD ASSY: CRYSTAL HOLDER	80009	670-6067-00
A69A3	670-9946-00		CIRCUIT BD ASSY: 2ND MIXER	80009	670-9946-00
A69A3C1021	283-5004-00		CAP, FXD, CER DI: 0.1UF, 10%, 25V	80009	283-5004-00
A69A3C5012	283-5003-00		CAP, FXD, CER DI: 0.01UF, 10%, 50V	80009	283-5003-00
A69A3C5014	283-5003-00		CAP, FXD, CER DI: 0.01UF, 10%, 50V	80009	283-5003-00
A69A3C5024	283-5004-00		CAP, FXD, CER DI: 0.1UF, 10%, 25V	80009	283-5004-00
A69A3C5026	283-5004-00		CAP, FXD, CER DI: 0.1UF, 10%, 25V	80009	283-5004-00
A69A3R3025	311-1228-00		RES, VAR, NONW: TRMR, 10K OHM, 0.5W	80009	311-1228-00
A69A3R4021	321-5030-00		RES, FXD, FILM: 10.0K, 1%, 0.125W	80009	321-5030-00
A69A3R5018	321-5030-00		RES, FXD, FILM: 10.0K, 1%, 0.125W	80009	321-5030-00
A69A3R5019	321-5030-00		RES, FXD, FILM: 10.0K, 1%, 0.125W	80009	321-5030-00
A69A3R5023	321-5030-00		RES, FXD, FILM: 10.0K, 1%, 0.125W	80009	321-5030-00
A69A3R5025	321-5030-00		RES, FXD, FILM: 10.0K, 1%, 0.125W	80009	321-5030-00
A69A3T1022	120-1237-00		TRANSFORMER, RF: TOROID	80009	120-1237-00
A69A3T3015	120-1237-00		TRANSFORMER, RF: TOROID	80009	120-1237-00
A69A3T4016	120-1057-00		TRANSFORMER, RF: TOROID	80009	120-1057-00
A69A3T4025	120-1150-00		TRANSFORMER, RF: TOROID	80009	120-1150-00
A69A3U5022	156-5281-00		IC, LINEAR: DMOS, MISC: BALANCED MIXER; SI8901Y, S015.150	80009	156-5281-00
A69A4	670-9947-00		CIRCUIT BD ASSY: LOCAL OSCILLATOR	80009	670-9947-00
A69A4C1010	290-5001-00		CAP, FXD, ELCTLT: 10UF, 20%, 16V	TK0900	ALCHIP-S16V10UF

Replaceable Electrical Parts
494A/494AP Service Vol.2

Component No.	Tektronix Part No.	Serial/Assembly No. Effective	Discnt	Name & Description	Mfr. Code	Mfr. Part No.
A69A4C1012	283-5004-00			CAP, FXD, CER DI: 0.1UF, 10%, 25V	80009	283-5004-00
A69A4C1021	283-5004-00			CAP, FXD, CER DI: 0.1UF, 10%, 25V	80009	283-5004-00
A69A4C1025	290-5001-00			CAP, FXD, ELCTLT: 10UF, 20%, 16V	TK0900	ALCHIP-516V10UF
A69A4C1032	281-0204-00			CAP, VAR, PLASTIC: 2-22PF, 100V	19701	2807C00222MJ02
A69A4C1131	283-5003-00			CAP, FXD, CER DI: 0.01UF, 10%, 50V	80009	283-5003-00
A69A4C1132	283-5004-00			CAP, FXD, CER DI: 0.1UF, 10%, 25V	80009	283-5004-00
A69A4C1135	283-5049-00			CAP, FXD, CER DI: 180PF, 5%, 50V	95275	VJ1206A181JXA
A69A4C1136	283-5049-00			CAP, FXD, CER DI: 180PF, 5%, 50V	95275	VJ1206A181JXA
A69A4C1146	283-5011-00			CAP, FXD, CER DI: 33PF, 5%, 50V	95275	VJ1206A330JXA
A69A4Q1126	151-5001-00			TRANSISTOR, SIG: BIPOLAR, NPN; 40V, 200MA, 300MHZ ,AMPLIFIER;MMBT3904L, TO-236/SOT-23, 8MM T&R	80009	151-5001-00
A69A4Q1135	151-5001-00			TRANSISTOR, SIG: BIPOLAR, NPN; 40V, 200MA, 300MHZ ,AMPLIFIER;MMBT3904L, TO-236/SOT-23, 8MM T&R	80009	151-5001-00
A69A4R1010	321-5050-00			RES, FXD, FILM: 33.2 OHM, 1%, 0.125W	57668	MCR18FWEA33E2
A69A4R1118	321-5018-00			RES, FXD, FILM: 1.00K, 1%, 0.125W	80009	321-5018-00
A69A4R1120	321-5018-00			RES, FXD, FILM: 1.00K, 1%, 0.125W	80009	321-5018-00
A69A4R1122	321-5018-00			RES, FXD, FILM: 1.00K, 1%, 0.125W	80009	321-5018-00
A69A4R1123	321-5018-00			RES, FXD, FILM: 1.00K, 1%, 0.125W	80009	321-5018-00
A69A4R1126	321-5030-00			RES, FXD, FILM: 10.0K, 1%, 0.125W	80009	321-5030-00
A69A4R1129	321-5025-00			RES, FXD, FILM: 3.92K, 1%, 0.125W	80009	321-5025-00
A69A4R1133	321-5022-00			RES, FXD, FILM: 2.21K, 1%, 0.125W	80009	321-5022-00
A69A4R1134	321-5030-00			RES, FXD, FILM: 10.0K, 1%, 0.125W	80009	321-5030-00
A69A4R1141	321-5018-00			RES, FXD, FILM: 1.00K, 1%, 0.125W	80009	321-5018-00
A69A4R1142	321-5034-00			RES, FXD, FILM: 22.1K, 1%, 0.125W	80009	321-5034-00
A69A4U1021	156-0991-00			IC, LINEAR: BIPOLAR, VOLTAGE REGULATOR; POSITIV E, 5.0V, 100MA, 5%; MC78L05ACP, TO-92	80009	156-0991-00
A69A4U1055	156-5003-00			IC, DIGITAL: LSTTL, FLIP FLOP; DUAL D-TYPE; 74LS 74, S014, 150, TUBE	01295	SN74LS74D
A70	670-9932-00	B010100	B010273	CIRCUIT BD ASSY: Z-AXIS	80009	670-9932-00
A70	670-9932-01	B010274	B020742	CIRCUIT BD ASSY: Z-AXIS	80009	670-9932-01
A70	670-9932-02	B020743		CIRCUIT BD ASSY: Z-AXIS; :388-9404-XX WIRED	80009	670-9932-02
A70C1026	283-0068-00			CAP, FXD, CER DI: 0.01UF, +100-0%, 500V	80009	283-0068-00
A70C1063	283-0068-00			CAP, FXD, CER DI: 0.01UF, +100-0%, 500V	80009	283-0068-00
A70C1064	283-0068-00			CAP, FXD, CER DI: 0.01UF, +100-0%, 500V	80009	283-0068-00
A70C2024	285-0862-00			CAP, FXD, PLASTIC: 0.001, 10%, 100V	19396	DU440774-28219
A70C2031	283-0167-00			CAP, FXD, CER DI: 0.1UF, 10%, 100V	80009	283-0167-00
A70C2035	283-0167-00			CAP, FXD, CER DI: 0.1UF, 10%, 100V	80009	283-0167-00
A70C2038	285-1056-00			CAP, FXD, PLASTIC: 1UF, 2%, 50V	14752	650B1A1056
A70C2041	283-0167-00			CAP, FXD, CER DI: 0.1UF, 10%, 100V	80009	283-0167-00
A70C2045	283-0167-00			CAP, FXD, CER DI: 0.1UF, 10%, 100V	80009	283-0167-00
A70C2051	283-0167-00			CAP, FXD, CER DI: 0.1UF, 10%, 100V	80009	283-0167-00
A70C2052	283-0167-00			CAP, FXD, CER DI: 0.1UF, 10%, 100V	80009	283-0167-00
A70C2053	283-0167-00			CAP, FXD, CER DI: 0.1UF, 10%, 100V	80009	283-0167-00
A70C2054	283-0220-00			CAP, FXD, CER DI: 0.01UF, 20%, 50V	04222	SR205C103MAA
A70C2055	283-0167-00			CAP, FXD, CER DI: 0.1UF, 10%, 100V	80009	283-0167-00
A70C2058	283-0220-00			CAP, FXD, CER DI: 0.01UF, 20%, 50V	04222	SR205C103MAA
A70C3026	283-0167-00			CAP, FXD, CER DI: 0.1UF, 10%, 100V	80009	283-0167-00
A70C3029	283-0167-00			CAP, FXD, CER DI: 0.1UF, 10%, 100V	80009	283-0167-00
A70C3031	283-0167-00			CAP, FXD, CER DI: 0.1UF, 10%, 100V	80009	283-0167-00
A70C3038	283-0167-00			CAP, FXD, CER DI: 0.1UF, 10%, 100V	80009	283-0167-00
A70C3039	283-0167-00			CAP, FXD, CER DI: 0.1UF, 10%, 100V	80009	283-0167-00
A70C3041	283-0167-00			CAP, FXD, CER DI: 0.1UF, 10%, 100V	80009	283-0167-00
A70C3051	283-0167-00			CAP, FXD, CER DI: 0.1UF, 10%, 100V	80009	283-0167-00
A70C3053	281-0619-00			CAP, FXD, CER DI: 1.2PF, +/-0.1PF, 500V	52763	2RDPZ007 1P208C
A70C4015	283-0156-00			CAP, FXD, CER DI: 1000PF, +80-20%, 200V	04222	SR152E102ZAA
A70C4016	283-0238-00			CAP, FXD, CER DI: 0.01UF, 10%, 50V	80009	283-0238-00
A70C4026	283-0177-00			CAP, FXD, CER DI: 1UF, +80-20%, 25V	04222	SR303E105ZAA
A70C4046	283-0167-00			CAP, FXD, CER DI: 0.1UF, 10%, 100V	80009	283-0167-00

Replaceable Electrical Parts
494A/494AP Service Vol.2

Component No.	Tektronix Part No.	Serial/Assembly No.		Name & Description	Mfr. Code	Mfr. Part No.
		Effective	Discont			
A70C4052	283-0167-00			CAP,FXD,CER DI:0.1UF,10%,100V	80009	283-0167-00
A70C4057	283-0167-00			CAP,FXD,CER DI:0.1UF,10%,100V	80009	283-0167-00
A70CR1043	152-0141-02			DIODE,SIG:,ULTRA FAST;40V,150MA,4NS,2PF;1N4152,DO-35,T&R	80009	152-0141-02
A70CR1045	152-0141-02			DIODE,SIG:,ULTRA FAST;40V,150MA,4NS,2PF;1N4152,DO-35,T&R	80009	152-0141-02
A70CR2013	152-0141-02			DIODE,SIG:,ULTRA FAST;40V,150MA,4NS,2PF;1N4152,DO-35,T&R	80009	152-0141-02
A70CR2029	152-0141-02			DIODE,SIG:,ULTRA FAST;40V,150MA,4NS,2PF;1N4152,DO-35,T&R	80009	152-0141-02
A70CR2058	152-0141-02			DIODE,SIG:,ULTRA FAST;40V,150MA,4NS,2PF;1N4152,DO-35,T&R	80009	152-0141-02
A70CR2059	152-0141-02			DIODE,SIG:,ULTRA FAST;40V,150MA,4NS,2PF;1N4152,DO-35,T&R	80009	152-0141-02
A70CR3016	152-0107-00			SEMICON DVC,DI:RECT,SI,400 V,400MA,A1	12969	"G727"
A70CR3017	152-0141-02			DIODE,SIG:,ULTRA FAST;40V,150MA,4NS,2PF;1N4152,DO-35,T&R	80009	152-0141-02
A70CR3018	152-0141-02			DIODE,SIG:,ULTRA FAST;40V,150MA,4NS,2PF;1N4152,DO-35,T&R	80009	152-0141-02
A70CR3022	152-0141-02			DIODE,SIG:,ULTRA FAST;40V,150MA,4NS,2PF;1N4152,DO-35,T&R	80009	152-0141-02
A70CR3023	152-0141-02			DIODE,SIG:,ULTRA FAST;40V,150MA,4NS,2PF;1N4152,DO-35,T&R	80009	152-0141-02
A70CR3024	152-0141-02			DIODE,SIG:,ULTRA FAST;40V,150MA,4NS,2PF;1N4152,DO-35,T&R	80009	152-0141-02
A70CR3028	152-0141-02	B010274		DIODE,SIG:,ULTRA FAST;40V,150MA,4NS,2PF;1N4152,DO-35,T&R	80009	152-0141-02
A70CR3051	152-0141-02			DIODE,SIG:,ULTRA FAST;40V,150MA,4NS,2PF;1N4152,DO-35,T&R	80009	152-0141-02
A70CR3059	152-0107-03			DIODE,RECT:;,400V,1A,10A IFSM;1N4004,DO-41	04713	1N4004
A70CR3060	152-0141-02			DIODE,SIG:,ULTRA FAST;40V,150MA,4NS,2PF;1N4152,DO-35,T&R	80009	152-0141-02
A70CR3066	152-0107-03			DIODE,RECT:;,400V,1A,10A IFSM;1N4004,DO-41	04713	1N4004
A70CR4012	152-0141-02			DIODE,SIG:,ULTRA FAST;40V,150MA,4NS,2PF;1N4152,DO-35,T&R	80009	152-0141-02
A70CR4013	152-0141-02			DIODE,SIG:,ULTRA FAST;40V,150MA,4NS,2PF;1N4152,DO-35,T&R	80009	152-0141-02
A70DS1062	150-1049-00			DIODE,OPTO:;,LED;RED/GREEN,BI-COLOR;T1 3/4,S PR 54MW	80009	150-1049-00
A70M1019	149-0046-01			METER,T TOTLZ:5000 HRS,55-700 VDC	80009	149-0046-01
A70Q1015	151-0301-00			TRANSISTOR,SIG:BIPOLAR,PNP;60V,600MA,200MHZ,AMPLIFIER;2N2907A,TO-18	80009	151-0301-00
A70Q1017	151-0302-00			TRANSISTOR,SIG:BIPOLAR,NPN;40V,800MA,300MHZ,AMPLIFIER;2N2222A,TO-18	80009	151-0302-00
A70Q1028	151-0301-00			TRANSISTOR,SIG:BIPOLAR,PNP;60V,600MA,200MHZ,AMPLIFIER;2N2907A,TO-18	80009	151-0301-00
A70Q2011	151-0190-00			TRANSISTOR,SIG:BIPOLAR,NPN;40V,200MA,300MHZ,AMPLIFIER;2N3904,TO-92 EBC	80009	151-0190-00
A70Q2022	151-0192-00			TRANSISTOR,SIG:BIPOLAR,NPN;25V,100MA,200MHZ,AMPLIFIER;MPS6521,TO-92 EBC	80009	151-0192-00
A70Q2025	151-0302-00			TRANSISTOR,SIG:BIPOLAR,NPN;40V,800MA,300MHZ,AMPLIFIER;2N2222A,TO-18	80009	151-0302-00
A70Q2042	151-0302-00			TRANSISTOR,SIG:BIPOLAR,NPN;40V,800MA,300MHZ,AMPLIFIER;2N2222A,TO-18	80009	151-0302-00
A70Q2044	151-0302-00			TRANSISTOR,SIG:BIPOLAR,NPN;40V,800MA,300MHZ,AMPLIFIER;2N2222A,TO-18	80009	151-0302-00
A70Q2059	151-0190-00			TRANSISTOR,SIG:BIPOLAR,NPN;40V,200MA,300MHZ,AMPLIFIER;2N3904,TO-92 EBC	80009	151-0190-00

Replaceable Electrical Parts
494A/494AP Service Vol.2

Component No.	Tektronix Part No.	Serial/Assembly No. Effective	Discont	Name & Description	Mfr. Code	Mfr. Part No.
A70Q2067	151-0188-00			TRANSISTOR, SIG: BIPOLAR, PNP; 40V, 200MA, 250MHZ ,AMPLIFIER; 2N3906, TO-92 EBC	80009	151-0188-00
A70Q3011	151-0190-00			TRANSISTOR, SIG: BIPOLAR, NPN; 40V, 200MA, 300MHZ ,AMPLIFIER; 2N3904, TO-92 EBC	80009	151-0190-00
A70Q3024	151-0290-00			TRANSISTOR, SIG: BIPOLAR, NPN; 60V, 5.0A, 50 MHZ, ,AMPLIFIER; 2N4896, TO-39	80009	151-0290-00
A70Q3025	151-0134-00			TRANSISTOR, SIG: BIPOLAR, PNP; 60V, 600MA, 200MHZ ,AMPLIFIER; 2N2905A, TO-39	80009	151-0134-00
A70Q3028	151-0391-00			TRANSISTOR, PWR: BIPOLAR, PNP; 45V, 2.0A, 100MHZ. ,AMPLIFIER, DARLINGTON; MPSU95, UNIWATT	80009	151-0391-00
A70Q3047	151-0302-00			TRANSISTOR, SIG: BIPOLAR, NPN; 40V, 800MA, 300MHZ ,AMPLIFIER; 2N2222A, TO-18	80009	151-0302-00
A70Q4058	151-0615-00	B010100	B020742	TRANSISTOR, PWR:	80009	151-0615-00
A70Q4058	151-0936-00	B020743		TRANSISTOR, PWR: BIPOLAR, NPN; 300V, 100MA, 50MHZ ,AMPLIFIER; BF871, TO-202 ECB	80009	151-0936-00
A70Q4059	151-0612-00	B010100	B020742	TRANSISTOR, PWR:	80009	151-0612-00
A70Q4059	151-0935-00	B020743		TRANSISTOR, PWR: BIPOLAR, PNP; 300V, 100MA, 50MHZ ,AMPLIFIER; BF872, TO-202 ECB	80009	151-0935-00
A70R1010	307-0696-00			RES, FXD, FI: 7.10K OHM, 2%, 0.15W EACH	80009	307-0696-00
A70R1015	321-0481-00			RES, FXD, FILM: 1M OHM, 1%, 0.125W, TC=TO	80009	321-0481-00
A70R1020	315-0103-00			RES, FXD, FILM: 10K OHM, 5%, 0.25W	80009	315-0103-00
A70R1021	311-1198-00			RES, VAR, NONWV: TRMR, 20K OHM, 0.5W	80009	311-1198-00
A70R1022	317-0244-00			RES, FXD, CMPSN: 240K OHM, 5%, 0.125W	80009	317-0244-00
A70R1023	315-0472-00			RES, FXD, FILM: 4.7K OHM, 5%, 0.25W	80009	315-0472-00
A70R1024	315-0472-00			RES, FXD, FILM: 4.7K OHM, 5%, 0.25W	80009	315-0472-00
A70R1025	315-0682-00			RES, FXD, FILM: 6.8K OHM, 5%, 0.25W	80009	315-0682-00
A70R1026	315-0682-00			RES, FXD, FILM: 6.8K OHM, 5%, 0.25W	80009	315-0682-00
A70R1027	311-1245-00			RES, VAR, NONWV: TRMR, 10K OHM, 0.5W	80009	311-1245-00
A70R1028	317-0103-00			RES, FXD, CMPSN: 10K OHM, 5%, 0.125W	80009	317-0103-00
A70R1030	311-1248-00			RES, VAR, NONWV: TRMR, 500 OHM, 0.5W	80009	311-1248-00
A70R1044	321-0382-00			RES, FXD, FILM: 93.1K OHM, 1%, 0.125W, TC=TO	07716	CEAD93101F
A70R1045	315-0222-00			RES, FXD, FILM: 2.2K OHM, 5%, 0.25W	80009	315-0222-00
A70R1046	315-0222-00			RES, FXD, FILM: 2.2K OHM, 5%, 0.25W	80009	315-0222-00
A70R1050	315-0221-00			RES, FXD, FILM: 220 OHM, 5%, 0.25W	80009	315-0221-00
A70R1051	311-1247-00			RES, VAR, NONWV: TRMR, 1MEG OHM, 0.5W	80009	311-1247-00
A70R1052	301-0473-00			RES, FXD, FILM: 47K OHM, 5%, 0.5W	19701	5053CX47K00J
A70R1054	315-0221-00			RES, FXD, FILM: 220 OHM, 5%, 0.25W	80009	315-0221-00
A70R1055	315-0102-00			RES, FXD, FILM: 1K OHM, 5%, 0.25W	80009	315-0102-00
A70R1056	321-0193-00			RES, FXD, FILM: 1K OHM, 1%, 0.125W, TC=TO	80009	321-0193-00
A70R1058	311-1241-00			RES, VAR, NONWV: TRMR, 100K OHM, 0.5W	80009	311-1241-00
A70R1064	301-0104-00			RES, FXD, FILM: 100K OHM, 5%, 0.5W	19701	5053CX100K0J
A70R1065	311-1198-00			RES, VAR, NONWV: TRMR, 20K OHM, 0.5W	80009	311-1198-00
A70R1066	301-0473-00			RES, FXD, FILM: 47K OHM, 5%, 0.5W	19701	5053CX47K00J
A70R1067	315-0101-00			RES, FXD, FILM: 100 OHM, 5%, 0.25W	80009	315-0101-00
A70R1068	315-0100-00			RES, FXD, FILM: 10 OHM, 5%, 0.25W	19701	5043CX10R00J
A70R2022	315-0472-00			RES, FXD, FILM: 4.7K OHM, 5%, 0.25W	80009	315-0472-00
A70R2024	321-0279-00			RES, FXD, FILM: 7.87K OHM, 1%, 0.125W, TC=TO	07716	CEAD78700F
A70R2025	315-0103-00			RES, FXD, FILM: 10K OHM, 5%, 0.25W	80009	315-0103-00
A70R2026	315-0682-00			RES, FXD, FILM: 6.8K OHM, 5%, 0.25W	80009	315-0682-00
A70R2027	315-0103-00			RES, FXD, FILM: 10K OHM, 5%, 0.25W	80009	315-0103-00
A70R2028	317-0103-00			RES, FXD, CMPSN: 10K OHM, 5%, 0.125W	80009	317-0103-00
A70R2050	321-0251-00			RES, FXD, FILM: 4.02K OHM, 1%, 0.125W, TC=TO	80009	321-0251-00
A70R2051	317-0242-00			RES, FXD, CMPSN: 2.4K OHM, 5%, 0.125W	80009	317-0242-00
A70R2052	315-0512-00			RES, FXD, FILM: 5.1K OHM, 5%, 0.25W	80009	315-0512-00
A70R2053	315-0162-00			RES, FXD, FILM: 1.6K OHM, 5%, 0.25W	80009	315-0162-00
A70R2054	317-0183-00			RES, FXD, CMPSN: 18K OHM, 5%, 0.125W	80009	317-0183-00
A70R2055	321-0660-00			RES, FXD, FILM: 417 OHM, 1%, 0.125W, TC=TO	07716	TO-55 417OHMS 1%
A70R2056	317-0912-00			RES, FXD, CMPSN: 9.1K OHM, 5%, 0.125W	80009	317-0912-00

Replaceable Electrical Parts
494A/494AP Service Vol.2

Component No.	Tektronix Part No.	Serial/Assembly No.		Name & Description	Mfr. Code	Mfr. Part No.
		Effective	Dscont			
A70R2057	301-0753-00			RES, FXD, FILM: 75K OHM, 5%, 0.5W	01121	EB7535
A70R2058	317-0101-00			RES, FXD, CMPSN: 100 OHM, 5%, 0.125W	80009	317-0101-00
A70R2059	321-0318-00			RES, FXD, FILM: 20.0K OHM, 1%, 0.125W, TC=TO	80009	321-0318-00
A70R2060	317-0622-00			RES, FXD, CMPSN: 6.2K OHM, 5%, 0.125W	80009	317-0622-00
A70R2063	315-0272-00			RES, FXD, FILM: 2.7K OHM, 5%, 0.25W	80009	315-0272-00
A70R2064	315-0471-00			RES, FXD, FILM: 470 OHM, 5%, 0.25W	80009	315-0471-00
A70R2065	317-0201-00			RES, FXD, CMPSN: 200 OHM, 5%, 0.125W	80009	317-0201-00
A70R2066	315-0563-00			RES, FXD, FILM: 56K OHM, 5%, 0.25W	80009	315-0563-00
A70R3010	315-0103-00			RES, FXD, FILM: 10K OHM, 5%, 0.25W	80009	315-0103-00
A70R3011	315-0102-00			RES, FXD, FILM: 1K OHM, 5%, 0.25W	80009	315-0102-00
A70R3012	315-0102-00			RES, FXD, FILM: 1K OHM, 5%, 0.25W	80009	315-0102-00
A70R3013	315-0102-00			RES, FXD, FILM: 1K OHM, 5%, 0.25W	80009	315-0102-00
A70R3016	315-0202-00			RES, FXD, FILM: 2K OHM, 5%, 0.25W	80009	315-0202-00
A70R3041	315-0103-00			RES, FXD, FILM: 10K OHM, 5%, 0.25W	80009	315-0103-00
A70R3045	315-0100-00			RES, FXD, FILM: 10K OHM, 5%, 0.25W	19701	5043CX10RR00J
A70R3050	315-0272-00			RES, FXD, FILM: 2.7K OHM, 5%, 0.25W	80009	315-0272-00
A70R3051	307-1254-00			RES NTWK, FXD, FI: PWR SUPPLY BALANCE DETECTOR	80009	307-1254-00
A70R3056	321-0431-00			RES, FXD, FILM: 301K OHM, 1%, 0.125W, TC=TO	07716	CEAD30102F
A70R3059	321-0431-00			RES, FXD, FILM: 301K OHM, 1%, 0.125W, TC=TO	07716	CEAD30102F
A70R3060	321-0318-00			RES, FXD, FILM: 20.0K OHM, 1%, 0.125W, TC=TO	80009	321-0318-00
A70R4010	315-0102-00			RES, FXD, FILM: 1K OHM, 5%, 0.25W	80009	315-0102-00
A70R4012	315-0103-00			RES, FXD, FILM: 10K OHM, 5%, 0.25W	80009	315-0103-00
A70R4013	315-0274-00			RES, FXD, FILM: 270K OHM, 5%, 0.25W	80009	315-0274-00
A70R4014	315-0101-00			RES, FXD, FILM: 100 OHM, 5%, 0.25W	80009	315-0101-00
A70R4016	315-0103-00			RES, FXD, FILM: 10K OHM, 5%, 0.25W	80009	315-0103-00
A70R4024	315-0473-00			RES, FXD, FILM: 47K OHM, 5%, 0.25W	80009	315-0473-00
A70R4058	315-0100-00			RES, FXD, FILM: 10 OHM, 5%, 0.25W	19701	5043CX10RR00J
A70S3052	260-2031-00			SWITCH, ROCKER: (7)SPST, 30VDC, 125MA	81073	76SB07S
A70U2034	156-1335-00			IC, DIGITAL: LSTTL, MULTIVIBRATOR; DUAL RETRIG MONOSTABLE; 96LS02, DIP16.3	80009	156-1335-00
A70U2036	156-0385-00			IC, DIGITAL: LSTTL, GATES; HEX INV; 74LS04, DIP14.3, TUBE	80009	156-0385-00
A70U2038	156-0467-00			IC, DIGITAL: LSTTL, GATES; QUAD 2-INPUT NAND BUFFER, OC; 74LS38, DIP14.3, TUBE	80009	156-0467-00
A70U2039	156-0452-00			IC, DIGITAL: LSTTL, GATES; 4-WIDE 2-INPUT AND-OR-INV; 74LS54, DIP14.3, TUBE	80009	156-0452-00
A70U2045	156-0469-00			IC, DIGITAL: LSTTL, DEMUX/DECODER; 3-TO-8 DECODER; 74LS138, DIP16.3, TUBE	80009	156-0469-00
A70U2051	156-1225-00			IC, LINEAR: BIPOLAR, COMPARATOR; DUAL, OPEN COLLECTOR, 300NS; LM393N, DIP08.3	01295	LM393P
A70U3029	156-0206-02			IC, DIGITAL: TTL, DRIVER; HIGH CURRENT MEMORY DRIVER; 75325, DIP16.3, TUBE, SCRNL	80009	156-0206-02
A70U3034	156-0206-02			IC, DIGITAL: TTL, DRIVER; HIGH CURRENT MEMORY DRIVER; 75325, DIP16.3, TUBE, SCRNL	80009	156-0206-02
A70U3038	156-0206-02			IC, DIGITAL: TTL, DRIVER; HIGH CURRENT MEMORY DRIVER; 75325, DIP16.3, TUBE, SCRNL	80009	156-0206-02
A70U3046	156-0913-00			IC, DIGITAL: LSTTL, FLIP FLOP; OCTAL D-TYPE, ENABLE; 74LS377, DIP20.3, TUBE	80009	156-0913-00
A70U3051	156-1225-00			IC, LINEAR: BIPOLAR, COMPARATOR; DUAL, OPEN COLLECTOR, 300NS; LM393N, DIP08.3	01295	LM393P
A70U3052	156-0914-00			IC, DIGITAL: LSTTL, BUFFER/DRIVER; OCTAL INV, 3-STATE; 74LS240, DIP20.3, TUBE	80009	156-0914-00
A70U4023	156-0067-00			IC, LINEAR: BIPOLAR, OP-AMP; ; 741C, DIP08.3	80009	156-0067-00
A70VR1052	152-0288-00			DIODE, ZENER: ; 140V, 5%, 0.4W; 1N5275B, DO-35 OR 7, TR	80009	152-0288-00
A70VR2014	152-0265-00			DIODE, ZENER: ; 24V, 5%, 0.4W; 1N970B, DO-7 OR 35. TR	80009	152-0265-00

Replaceable Electrical Parts
494A/494AP Service Vol.2

Component No.	Tektronix Part No.	Serial/Assembly No. Effective	Discont	Name & Description	Mfr. Code	Mfr. Part No.
A70VR2053	152-0662-00			DIODE,ZENER: ;5V,1%,0.4W;1N751 FMLY,DO-7 OR 35,TR	04713	SZG195RL
A70VR2062	152-0087-00			DIODE,ZENER: ;100V,5%,1W;1N3044B,DO-13	80009	152-0087-00
A70VR3015	152-0281-00			DIODE,ZENER:22V,5%,0.4W;1N969B,DO-35,OR 7,T R	80009	152-0281-00
A72	670-9090-04			CIRCUIT BD ASSY:SWEEP	80009	670-9090-04
A72C1010	283-5004-00			CAP,FXD,CER DI:0.1UF,10%,25V	80009	283-5004-00
A72C1020	283-5004-00			CAP,FXD,CER DI:0.1UF,10%,25V	80009	283-5004-00
A72C1030	283-5004-00			CAP,FXD,CER DI:0.1UF,10%,25V	80009	283-5004-00
A72C1044	283-5004-00			CAP,FXD,CER DI:0.1UF,10%,25V	80009	283-5004-00
A72C1046	283-5004-00			CAP,FXD,CER DI:0.1UF,10%,25V	80009	283-5004-00
A72C1061	295-0171-00			CAP SET,MATCHED:510PF,5UF,0.05UF,MATCHED 1%	84411	TEK140UF(ST)5100
A72C1065	295-0171-00			CAP SET,MATCHED:510PF,5UF,0.05UF,MATCHED 1%	84411	TEK140UF(ST)5100
A72C2018	283-5004-00			CAP,FXD,CER DI:0.1UF,10%,25V	80009	283-5004-00
A72C2019	283-5004-00			CAP,FXD,CER DI:0.1UF,10%,25V	80009	283-5004-00
A72C2030	283-5004-00			CAP,FXD,CER DI:0.1UF,10%,25V	80009	283-5004-00
A72C2040	283-5001-00			CAP,FXD,CER DI:100PF,5%,50V	80009	283-5001-00
A72C2042	283-5001-00			CAP,FXD,CER DI:100PF,5%,50V	80009	283-5001-00
A72C2044	283-5001-00			CAP,FXD,CER DI:100PF,5%,50V	80009	283-5001-00
A72C2046	283-0212-00			CAP,FXD,CER DI:2UF,20%,50V	05397	C340C205M5U1CA
A72C2048	283-5004-00			CAP,FXD,CER DI:0.1UF,10%,25V	80009	283-5004-00
A72C2050	283-5001-00			CAP,FXD,CER DI:100PF,5%,50V	80009	283-5001-00
A72C2054	290-0973-00			CAP,FXD,ELCTLT:100UF,20%,25VDC	24165	513D107M025BB4D
A72C2060	295-0171-00			CAP SET,MATCHED:510PF,5UF,0.05UF,MATCHED 1%	84411	TEK140UF(ST)5100
A72C3012	283-5004-00			CAP,FXD,CER DI:0.1UF,10%,25V	80009	283-5004-00
A72C3018	283-5004-00			CAP,FXD,CER DI:0.1UF,10%,25V	80009	283-5004-00
A72C3025	283-5004-00			CAP,FXD,CER DI:0.1UF,10%,25V	80009	283-5004-00
A72C3027	283-0212-00			CAP,FXD,CER DI:2UF,20%,50V	05397	C340C205M5U1CA
A72C3030	290-5001-00			CAP,FXD,ELCTLT:10UF,20%,16V	TK0900	ALCHIP-S16V10UF
A72C3032	283-5003-00			CAP,FXD,CER DI:0.01UF,10%,50V	80009	283-5003-00
A72C3034	283-5004-00			CAP,FXD,CER DI:0.1UF,10%,25V	80009	283-5004-00
A72C3036	283-5001-00			CAP,FXD,CER DI:100PF,5%,50V	80009	283-5001-00
A72C3038	283-0212-00			CAP,FXD,CER DI:2UF,20%,50V	05397	C340C205M5U1CA
A72C3039	283-5001-00			CAP,FXD,CER DI:100PF,5%,50V	80009	283-5001-00
A72C3040	283-5000-00			CAP,FXD,CER DI:10PF,5%,50V	80009	283-5000-00
A72C3042	290-0943-00			CAP,FXD,ELCTLT:47UF,+50-20%,25V	55680	UVX1V470MPA
A72C3044	290-0943-00			CAP,FXD,ELCTLT:47UF,+50-20%,25V	55680	UVX1V470MPA
A72C3045	283-0108-00			CAP,FXD,CER DI:220PF,10%,200V	04222	SR152A221KAA
A72C3046	283-5004-00			CAP,FXD,CER DI:0.1UF,10%,25V	80009	283-5004-00
A72C3050	290-0768-00			CAP,FXD,ELCTLT:10UF,+50-20%,100WVDC	80009	290-0768-00
A72C3052	283-5003-00			CAP,FXD,CER DI:0.01UF,10%,50V	80009	283-5003-00
A72C3054	283-5001-00			CAP,FXD,CER DI:100PF,5%,50V	80009	283-5001-00
A72C3056	283-5003-00			CAP,FXD,CER DI:0.01UF,10%,50V	80009	283-5003-00
A72C3058	283-5003-00			CAP,FXD,CER DI:0.01UF,10%,50V	80009	283-5003-00
A72C4025	283-5003-00			CAP,FXD,CER DI:0.01UF,10%,50V	80009	283-5003-00
A72C4036	283-5004-00			CAP,FXD,CER DI:0.1UF,10%,25V	80009	283-5004-00
A72C4040	283-5004-00			CAP,FXD,CER DI:0.1UF,10%,25V	80009	283-5004-00
A72C4042	283-5004-00			CAP,FXD,CER DI:0.1UF,10%,25V	80009	283-5004-00
A72C4044	283-5004-00			CAP,FXD,CER DI:0.1UF,10%,25V	80009	283-5004-00
A72C4046	283-5004-00			CAP,FXD,CER DI:0.1UF,10%,25V	80009	283-5004-00
A72C4048	283-5004-00			CAP,FXD,CER DI:0.1UF,10%,25V	80009	283-5004-00
A72C4050	283-5004-00			CAP,FXD,CER DI:0.1UF,10%,25V	80009	283-5004-00
A72C4052	283-5004-00			CAP,FXD,CER DI:0.1UF,10%,25V	80009	283-5004-00
A72C4058	283-5004-00			CAP,FXD,CER DI:0.1UF,10%,25V	80009	283-5004-00
A72CR1051	152-0246-00	B010100	B010499	SEMICOND DVC,DI:SW,SI,40V,200MA,DO-7	80009	152-0246-00
A72CR1051	152-0324-00	B010500		DIODE,SIG: ;50V,1.1VF,225MA,50PA,3.7PF,1.0U S;MT5128,DO-35,T&R	14552	MT5128
A72CR1052	152-0246-00	B010100	B010499	SEMICOND DVC,DI:SW,SI,40V,200MA,DO-7	80009	152-0246-00

Replaceable Electrical Parts
494A/494AP Service Vol.2

Component No.	Tektronix Part No.	Serial/Assembly No. Effective Dscont	Name & Description	Mfr. Code	Mfr. Part No.
A72CR1052	152-0324-00	B010500	DIODE, SIG: ,; 50V, 1.1VF, 225MA, 50PA, 3.7PF, 1.0U S; MT5128, DO-35, T&R	14552	MT5128
A72CR2030	152-5004-00		DIODE, SIG: , ULTRA FAST; 70V, 0.15A, 6NS, SER-PAI R; BAV99, SOT-23, 8MM TR	25088	BAV99T
A72CR3030	152-5005-00		DIODE, SIG: , ULTRA FAST; 70V, 0.15A, 6NS, COM-AND DE; BAW56, SOT-23, 8MM TR	80009	152-5005-00
A72CR3040	152-5004-00		DIODE, SIG: , ULTRA FAST; 70V, 0.15A, 6NS, SER-PAI R; BAV99, SOT-23, 8MM TR	25088	BAV99T
A72CR4025	152-5004-00		DIODE, SIG: , ULTRA FAST; 70V, 0.15A, 6NS, SER-PAI R; BAV99, SOT-23, 8MM TR	25088	BAV99T
A72L4040	108-0417-01		COIL, RF: FIXED, 110UH	80009	108-0417-01
A72Q1062	151-5002-00		TRANSISTOR, SIG: JFET, N-CH; 5V, 75MA, 60 OHM, SWI TCH; MMBF4392L, SOT-23, 8MM T&R	80009	151-5002-00
A72Q2030	151-0232-00		TRANSISTOR, SIG: BIPOLAR, NPN; 45V, 30MA, 60MHZ, A MPLIFIER, TWO DIE DUAL; 2N2918, TO-78	80009	151-0232-00
A72Q2060	151-5002-00		TRANSISTOR, SIG: JFET, N-CH; 5V, 75MA, 60 OHM, SWI TCH; MMBF4392L, SOT-23, 8MM T&R	80009	151-5002-00
A72Q2064	151-5002-00		TRANSISTOR, SIG: JFET, N-CH; 5V, 75MA, 60 OHM, SWI TCH; MMBF4392L, SOT-23, 8MM T&R	80009	151-5002-00
A72Q2068	151-5002-00		TRANSISTOR, SIG: JFET, N-CH; 5V, 75MA, 60 OHM, SWI TCH; MMBF4392L, SOT-23, 8MM T&R	80009	151-5002-00
A72Q3015	151-5001-00		TRANSISTOR, SIG: BIPOLAR, NPN; 40V, 200MA, 300MHZ , AMPLIFIER; MMBT3904L, TO-236/SOT-23, 8MM T&R	80009	151-5001-00
A72Q3020	151-5001-00		TRANSISTOR, SIG: BIPOLAR, NPN; 40V, 200MA, 300MHZ , AMPLIFIER; MMBT3904L, TO-236/SOT-23, 8MM T&R	80009	151-5001-00
A72Q3025	151-5001-00		TRANSISTOR, SIG: BIPOLAR, NPN; 40V, 200MA, 300MHZ , AMPLIFIER; MMBT3904L, TO-236/SOT-23, 8MM T&R	80009	151-5001-00
A72Q3030	151-0232-00		TRANSISTOR, SIG: BIPOLAR, NPN; 45V, 30MA, 60MHZ, A MPLIFIER, TWO DIE DUAL; 2N2918, TO-78	80009	151-0232-00
A72Q4032	151-5001-00		TRANSISTOR, SIG: BIPOLAR, NPN; 40V, 200MA, 300MHZ , AMPLIFIER; MMBT3904L, TO-236/SOT-23, 8MM T&R	80009	151-5001-00
A72Q4037	151-5001-00		TRANSISTOR, SIG: BIPOLAR, NPN; 40V, 200MA, 300MHZ , AMPLIFIER; MMBT3904L, TO-236/SOT-23, 8MM T&R	80009	151-5001-00
A72R1010	321-5030-00		RES, FXD, FILM: 10.0K, 1%, 0.125W	80009	321-5030-00
A72R1020	321-5030-00		RES, FXD, FILM: 10.0K, 1%, 0.125W	80009	321-5030-00
A72R1050	321-5017-00		RES, FXD, FILM: 825 OHM, 1%, 0.125W	80009	321-5017-00
A72R1051	321-5030-00		RES, FXD, FILM: 10.0K, 1%, 0.125W	80009	321-5030-00
A72R1052	311-1239-00		RES, VAR, TRMR: CERMET; 2.5K OHM, 10%, 0.5W, 0.375 SQ, SIDE ADJUST	80009	311-1239-00
A72R1053	321-5030-00		RES, FXD, FILM: 10.0K, 1%, 0.125W	80009	321-5030-00
A72R1055	321-5029-00		RES, FXD, FILM: 8.25K, 1%, 0.125W	80009	321-5029-00
A72R1057	321-5030-00		RES, FXD, FILM: 10.0K, 1%, 0.125W	80009	321-5030-00
A72R1059	321-5030-00		RES, FXD, FILM: 10.0K, 1%, 0.125W	80009	321-5030-00
A72R1060	321-0384-00		RES, FXD, FILM: 97.6K OHM, 1%, 0.125W, TC=TO	07716	CEAD97601F
A72R1062	311-1240-00		RES, VAR, NONW: TRMR, 25K OHM, 10%, 0.5W	80009	311-1240-00
A72R1064	321-5047-00		RES, FXD, FILM: 100K, 1%, 0.125W	80009	321-5047-00
A72R1066	321-5015-00		RES, FXD, FILM: 562 OHM, 1%, 0.125W	80009	321-5015-00
A72R1068	321-0393-00		RES, FXD, FILM: 121K OHM, 1%, 0.125W, TC=TO	80009	321-0393-00
A72R2010	321-0163-00		RES, FXD, FILM: 487 OHM, 1%, 0.125W, TC=TO	07716	CEAD487R0F
A72R2012	321-0256-00		RES, FXD, FILM: 4.53K OHM, 1%, 0.125W, TC=TO	80009	321-0256-00
A72R2013	321-5047-00		RES, FXD, FILM: 100K, 1%, 0.125W	80009	321-5047-00
A72R2015	321-5032-00		RES, FXD, FILM: 15.0K, 1%, 0.125W	80009	321-5032-00
A72R2017	321-5030-00		RES, FXD, FILM: 10.0K, 1%, 0.125W	80009	321-5030-00
A72R2018	321-5030-00		RES, FXD, FILM: 10.0K, 1%, 0.125W	80009	321-5030-00
A72R2019	321-5030-00		RES, FXD, FILM: 10.0K, 1%, 0.125W	80009	321-5030-00
A72R2020	321-5015-00		RES, FXD, FILM: 562 OHM, 1%, 0.125W	80009	321-5015-00
A72R2022	321-5030-00		RES, FXD, FILM: 10.0K, 1%, 0.125W	80009	321-5030-00
A72R2024	321-5030-00		RES, FXD, FILM: 10.0K, 1%, 0.125W	80009	321-5030-00

Replaceable Electrical Parts
494A/494AP Service Vol.2

Component No.	Tektronix Part No.	Serial/Assembly No. Effective Dscnt	Name & Description	Mfr. Code	Mfr. Part No.
A72R2026	321-5023-00		RES, FXD, FILM: 2.74K, 1%, 0.125W	80009	321-5023-00
A72R2028	321-5021-00		RES, FXD, FILM: 1.82K, 1%, 0.125W	80009	321-5021-00
A72R2030	321-5030-00		RES, FXD, FILM: 10.0K, 1%, 0.125W	80009	321-5030-00
A72R2031	317-0104-00		RES, FXD, CMPSN: 100K OHM, 5%, 0.125W	80009	317-0104-00
A72R2032	321-5022-00		RES, FXD, FILM: 2.21K, 1%, 0.125W	80009	321-5022-00
A72R2034	321-5018-00		RES, FXD, FILM: 1.00K, 1%, 0.125W	80009	321-5018-00
A72R2034	321-5019-00		RES, FXD, FILM: 1.21K, 1%, 0.125W	80009	321-5019-00
A72R2036	321-5030-00		RES, FXD, FILM: 10.0K, 1%, 0.125W	80009	321-5030-00
A72R2040	321-5030-00		RES, FXD, FILM: 10.0K, 1%, 0.125W	80009	321-5030-00
A72R2042	321-5028-00		RES, FXD, FILM: 6.81K, 1%, 0.125W	80009	321-5028-00
A72R2044	315-0302-00		RES, FXD, FILM: 3K OHM, 5%, 0.25W	80009	315-0302-00
A72R2046	321-5026-00		RES, FXD, FILM: 4.75K, 1%, 0.125W	80009	321-5026-00
A72R2048	321-5030-00		RES, FXD, FILM: 10.0K, 1%, 0.125W	80009	321-5030-00
A72R2050	321-5023-00		RES, FXD, FILM: 2.74K, 1%, 0.125W	80009	321-5023-00
A72R2052	321-5030-00		RES, FXD, FILM: 10.0K, 1%, 0.125W	80009	321-5030-00
A72R2054	321-5006-00		RES, FXD, FILM: 100 OHM, 1%, 0.125W	80009	321-5006-00
A72R2060	321-5048-00		RES, FXD, FILM: 332K, 1%, 0.125W	80009	321-5048-00
A72R2064	321-5047-00		RES, FXD, FILM: 100K, 1%, 0.125W	80009	321-5047-00
A72R2068	321-5047-00		RES, FXD, FILM: 100K, 1%, 0.125W	80009	321-5047-00
A72R2069	321-5026-00		RES, FXD, FILM: 4.75K, 1%, 0.125W	80009	321-5026-00
A72R3010	321-0259-00		RES, FXD, FILM: 4.87K OHM, 1%, 0.125W, TC=TO	07716	CEAD48700F
A72R3012	315-0106-00		RES, FXD, FILM: 10M OHM, 5%, 0.25W	01121	CB1065
A72R3014	321-5006-00		RES, FXD, FILM: 100 OHM, 1%, 0.125W	80009	321-5006-00
A72R3016	321-5006-00		RES, FXD, FILM: 100 OHM, 1%, 0.125W	80009	321-5006-00
A72R3018	321-5021-00		RES, FXD, FILM: 1.82K, 1%, 0.125W	80009	321-5021-00
A72R3020	321-5023-00		RES, FXD, FILM: 2.74K, 1%, 0.125W	80009	321-5023-00
A72R3021	321-5021-00		RES, FXD, FILM: 1.82K, 1%, 0.125W	80009	321-5021-00
A72R3022	321-5032-00		RES, FXD, FILM: 15.0K, 1%, 0.125W	80009	321-5032-00
A72R3023	321-5030-00		RES, FXD, FILM: 10.0K, 1%, 0.125W	80009	321-5030-00
A72R3024	321-5049-00		RES, FXD, FILM: 1 MEG, 1%, 0.125W	80009	321-5049-00
A72R3025	321-5023-00		RES, FXD, FILM: 2.74K, 1%, 0.125W	80009	321-5023-00
A72R3026	321-5032-00		RES, FXD, FILM: 15.0K, 1%, 0.125W	80009	321-5032-00
A72R3027	321-5030-00		RES, FXD, FILM: 10.0K, 1%, 0.125W	80009	321-5030-00
A72R3028	315-0475-00		RES, FXD, FILM: 4.7M OHM, 5%, 0.25W	01121	CB4755
A72R3029	321-5030-00		RES, FXD, FILM: 10.0K, 1%, 0.125W	80009	321-5030-00
A72R3030	321-5047-00		RES, FXD, FILM: 100K, 1%, 0.125W	80009	321-5047-00
A72R3031	321-5013-00		RES, FXD, FILM: 392 OHM, 1%, 0.125W	80009	321-5013-00
A72R3032	321-5018-00		RES, FXD, FILM: 1.00K, 1%, 0.125W	80009	321-5018-00
A72R3033	321-5022-00		RES, FXD, FILM: 2.21K, 1%, 0.125W	80009	321-5022-00
A72R3034	321-5023-00		RES, FXD, FILM: 2.74K, 1%, 0.125W	80009	321-5023-00
A72R3035	321-5024-00		RES, FXD, FILM: 3.32K, 1%, 0.125W	80009	321-5024-00
A72R3036	321-5021-00		RES, FXD, FILM: 1.82K, 1%, 0.125W	80009	321-5021-00
A72R3037	321-5036-00		RES, FXD, FILM: 33.2K, 1%, 0.125W	80009	321-5036-00
A72R3038	317-0154-00		RES, FXD, CMPSN: 150K OHM, 5%, 0.125W	80009	317-0154-00
A72R3040	321-5030-00		RES, FXD, FILM: 10.0K, 1%, 0.125W	80009	321-5030-00
A72R3042	321-0317-00		RES, FXD, FILM: 19.6K OHM, 1%, 0.125W, TC=TO	07716	CEAD19601F
A72R3043	321-0277-00		RES, FXD, FILM: 7.50K OHM, 1%, 0.125W, TC=TO	2M627	CRA18CRB14F7.5K
A72R3044	321-5018-00		RES, FXD, FILM: 1.00K, 1%, 0.125W	80009	321-5018-00
A72R3045	321-5004-00		RES, FXD, FILM: 22.1 OHM, 1%, 0.125W	80009	321-5004-00
A72R3047	321-5026-00		RES, FXD, FILM: 4.75K, 1%, 0.125W	80009	321-5026-00
A72R3049	321-5026-00		RES, FXD, FILM: 4.75K, 1%, 0.125W	80009	321-5026-00
A72R3050	321-5030-00		RES, FXD, FILM: 10.0K, 1%, 0.125W	80009	321-5030-00
A72R3051	321-5028-00		RES, FXD, FILM: 6.81K, 1%, 0.125W	80009	321-5028-00
A72R3052	321-5030-00		RES, FXD, FILM: 10.0K, 1%, 0.125W	80009	321-5030-00
A72R3053	321-5043-00		RES, FXD, FILM: 47.5 OHM, 1%, 0.125W	80009	321-5043-00
A72R3054	321-5025-00		RES, FXD, FILM: 3.92K, 1%, 0.125W	80009	321-5025-00
A72R3055	321-5030-00		RES, FXD, FILM: 10.0K, 1%, 0.125W	80009	321-5030-00
A72R3056	321-5030-00		RES, FXD, FILM: 10.0K, 1%, 0.125W	80009	321-5030-00

Replaceable Electrical Parts
494A/494AP Service Vol.2

Component No.	Tektronix	Serial/Assembly No.		Name & Description	Mfr.	Mfr. Part No.
	Part No.	Effective	Discont		Code	
A72R3057	321-5043-00			RES, FXD, FILM:47.5 OHM, 1%, 0.125W	80009	321-5043-00
A72R3058	321-5033-00			RES, FXD, FILM:18.2K, 1%, 0.125W	80009	321-5033-00
A72R3059	321-0352-00			RES, FXD, FILM:45.3K OHM, 1%, 0.125W, TC=TO	07716	CEAD45301F
A72R3060	321-0280-00			RES, FXD, FILM:8.06K OHM, 1%, 0.125W, TC=TO	80009	321-0280-00
A72R3062	321-0807-00			RES, FXD, FILM:900K OHM, 1%, 0.125W, TC=TO	80009	321-0807-00
A72R3064	321-1627-06			RES, FXD, FILM:731.3K OHM, 0.25%, 0.125W, TC=T9	80009	321-1627-06
A72R3066	321-0510-07			RES, FXD, FILM:2.00 MEG OHM, 0.1%, 0.125W, TC=T9	80009	321-0510-07
A72R4010	321-5032-00			RES, FXD, FILM:15.0K, 1%, 0.125W	80009	321-5032-00
A72R4012	321-5030-00			RES, FXD, FILM:10.0K, 1%, 0.125W	80009	321-5030-00
A72R4014	321-5030-00			RES, FXD, FILM:10.0K, 1%, 0.125W	80009	321-5030-00
A72R4016	321-5030-00			RES, FXD, FILM:10.0K, 1%, 0.125W	80009	321-5030-00
A72R4020	321-5018-00			RES, FXD, FILM:1.00K, 1%, 0.125W	80009	321-5018-00
A72R4022	321-5006-00			RES, FXD, FILM:100 OHM, 1%, 0.125W	80009	321-5006-00
A72R4024	321-5006-00			RES, FXD, FILM:100 OHM, 1%, 0.125W	80009	321-5006-00
A72R4026	321-5030-00			RES, FXD, FILM:10.0K, 1%, 0.125W	80009	321-5030-00
A72R4032	321-5030-00			RES, FXD, FILM:10.0K, 1%, 0.125W	80009	321-5030-00
A72R4036	321-5006-00			RES, FXD, FILM:100 OHM, 1%, 0.125W	80009	321-5006-00
A72R4040	321-5043-00			RES, FXD, FILM:47.5 OHM, 1%, 0.125W	80009	321-5043-00
A72R4042	321-5043-00			RES, FXD, FILM:47.5 OHM, 1%, 0.125W	80009	321-5043-00
A72R4044	321-5043-00			RES, FXD, FILM:47.5 OHM, 1%, 0.125W	80009	321-5043-00
A72R4046	321-5000-00			RES, FXD, FILM:10 OHM, 1%, 0.125W	57668	MCR18EZHFW10E
A72R4048	321-5027-00			RES, FXD, FILM:5.62K, 1%, 0.125W	80009	321-5027-00
A72R4050	321-5006-00			RES, FXD, FILM:100 OHM, 1%, 0.125W	80009	321-5006-00
A72R4054	321-0303-00			RES, FXD, FILM:14.0K OHM, 1%, 0.125W, TC=TO	07716	CEAD 14001F
A72R4056	321-5018-00			RES, FXD, FILM:1.00K, 1%, 0.125W	80009	321-5018-00
A72R4060	321-0367-00			RES, FXD, FILM:64.9K OHM, 1%, 0.125W, TC=TO	07716	CEAD64901F
A72R4061	321-0350-00			RES, FXD, FILM:43.2K OHM, 1%, 0.125W, TC=TO	80009	321-0350-00
A72R4062	321-0307-00			RES, FXD, FILM:15.4K OHM, 1%, 0.125W, TC=TO	80009	321-0307-00
A72R4063	321-0350-00			RES, FXD, FILM:43.2K OHM, 1%, 0.125W, TC=TO	80009	321-0350-00
A72R4064	321-0983-00			RES, FXD, FILM:4.5 MEG OHM, 1%, 0.125W, TC=TO	80009	321-0983-00
A72R4065	321-0321-00			RES, FXD, FILM:21.5K OHM, 1%, 0.125W, TC=TO	07716	CEAD21501F
A72R4066	321-1484-03			RES, FXD, FILM:1.09M OHM, 0.25%, 0.125W	80009	321-1484-03
A72R4067	321-0995-00			RES, FXD, FILM:549K OHM, 1%, 0.125W, TC=TO	01121	
A72R4068	321-0427-00			RES, FXD, FILM:274K OHM, 1%, 0.125W, TC=TO	01121	
A72R4069	321-1388-01			RES, FXD, FILM:109K OHM, 0.5%, 0.125W, TC=TO	01121	ADVISE
A72U1010	156-5003-00			IC, DIGITAL: LSTTL, FLIP FLOP; DUAL D-TYPE; 74LS 74, SO14. 150, TUBE	01295	SN74LS74D
A72U1015	156-5037-00			IC, DIGITAL: LSTTL, SCHMITT TRIG; HEX INV; 74LS1 4, SO14. 150, TUBE	80009	156-5037-00
A72U1016	156-5003-00			IC, DIGITAL: LSTTL, FLIP FLOP; DUAL D-TYPE; 74LS 74, SO14. 150, TUBE	01295	SN74LS74D
A72U1017	156-5042-00			IC, DIGITAL: TTL, BUFFER/DRIVER; HEX INV, OC, H IGH VOLTAGE INTERFACE; 7406, SO14. 150, TUBE	01295	SN7406D
A72U1020	156-5001-00			IC, DIGITAL: LSTTL, GATES; QUAD 2-INPUT NAND; 74 LS00, SO14. 150, TUBE	01295	SN74LS00D
A72U1025	156-5003-00			IC, DIGITAL: LSTTL, FLIP FLOP; DUAL D-TYPE; 74LS 74, SO14. 150, TUBE	01295	SN74LS74D
A72U1026	156-5001-00			IC, DIGITAL: LSTTL, GATES; QUAD 2-INPUT NAND; 74 LS00, SO14. 150, TUBE	01295	SN74LS00D
A72U1027	156-5039-00			IC, DIGITAL: LSTTL, FLIP FLOP; HEX D-TYPE, WITH CLEAR; 74LS174, SO16. 150, TUBE	80009	156-5039-00
A72U1030	156-5033-00			IC, DIGITAL: LSTTL, DEMUX/DECODER; 3-TO-8 DECOD ER; 74LS138, SO16. 150, TUBE	80009	156-5033-00
A72U1035	156-5039-00			IC, DIGITAL: LSTTL, FLIP FLOP; HEX D-TYPE, WITH CLEAR; 74LS174, SO16. 150, TUBE	80009	156-5039-00
A72U1040	156-5039-00			IC, DIGITAL: LSTTL, FLIP FLOP; HEX D-TYPE, WITH CLEAR; 74LS174, SO16. 150, TUBE	80009	156-5039-00

Replaceable Electrical Parts
494A/494AP Service Vol.2

Component No.	Tektronix Part No.	Serial/Assembly No. Effective Discnt	Name & Description	Mfr. Code	Mfr. Part No.
A72U1045	156-5009-00		IC,DIGITAL:LSTTL,FLIP FLOP;OCTAL D-TYPE, CL EAR;74LS273,S020.300,TUBE	80009	156-5009-00
A72U1047	156-1548-01		IC,CONVERTER:CMOS,D/A;12 BIT,CURRENT OUT,MU LTIPLYING;AD7541AJN,DIP18.3	80009	156-1548-01
A72U1050	156-1270-00		IC,MISC:BIFET,ANALOG MUX;8 CHANNEL, 850 OHM . 1.6US;LF13508,DIP16.3	80009	156-1270-00
A72U1055	156-1582-00		IC,LINEAR:BIPOLAR,OP-AMP;LOW OFFSET VOLTAGE ;OP07CN,DIP08.3	80009	156-1582-00
A72U1060	156-5019-00		IC,LINEAR:BIPOLAR,COMPARATOR;DUAL,SINGLE SU PPLY;LM393D,S08.150,TUBE	80009	156-5019-00
A72U2010	156-5001-00		IC,DIGITAL:LSTTL,GATES;QUAD 2-INPUT NAND;74 LS00,S014.150,TUBE	01295	SN74LS00D
A72U2011	156-5047-00		IC,DIGITAL:LSTTL,MUX;QUAD 2-TO-1 DATA SELEC TOR, NONINV;74LS157,S016.150,TUBE	80009	156-5047-00
A72U2015	156-5040-00		IC,DIGITAL:LSTTL,GATES;QUAD 2-INPUT XNOR, 0 C;74LS266,S014.150,TUBE	01295	SN74LS266D
A72U2017	156-5003-00		IC,DIGITAL:LSTTL,FLIP FLOP;DUAL D-TYPE;74LS 74,S014.150,TUBE	01295	SN74LS74D
A72U2020	156-5032-00		IC,DIGITAL:LSTTL,GATES;QUAD 2-INPUT NOR;74L S02,S014.150,TUBE	80009	156-5032-00
A72U2025	156-5003-00		IC,DIGITAL:LSTTL,FLIP FLOP;DUAL D-TYPE;74LS 74,S014.150,TUBE	01295	SN74LS74D
A72U2026	156-5038-00		IC,DIGITAL:LSTTL,MUX;DUAL 4-TO-1 DATA SELEC TOR;74LS153,S016.150,TUBE	80009	156-5038-00
A72U2030	156-5039-00		IC,DIGITAL:LSTTL,FLIP FLOP;HEX D-TYPE, WITH CLEAR;74LS174,S016.150,TUBE	80009	156-5039-00
A72U2040	156-1582-00		IC,LINEAR:BIPOLAR,OP-AMP;LOW OFFSET VOLTAGE ;OP07CN,DIP08.3	80009	156-1582-00
A72U2045	156-1582-00		IC,LINEAR:BIPOLAR,OP-AMP;LOW OFFSET VOLTAGE ;OP07CN,DIP08.3	80009	156-1582-00
A72U2050	156-5019-00		IC,LINEAR:BIPOLAR,COMPARATOR;DUAL,SINGLE SU PPLY;LM393D,S08.150,TUBE	80009	156-5019-00
A72U3010	156-5019-00		IC,LINEAR:BIPOLAR,COMPARATOR;DUAL,SINGLE SU PPLY;LM393D,S08.150,TUBE	80009	156-5019-00
A72U3025	156-5019-00		IC,LINEAR:BIPOLAR,COMPARATOR;DUAL,SINGLE SU PPLY;LM393D,S08.150,TUBE	80009	156-5019-00
A72U3045	156-0742-00		IC,LINEAR:BIPOLAR,OP-AMP;HIGH SLEW RATE;LM3 18N,DIP08.3	01295	LM318P
A72U3050	156-5017-01		IC,LINEAR:BIPOLAR,OP-AMP;DUAL;MC1458D,S08.1 50,12MM T/R	80009	156-5017-01
A72U3060	156-1270-00		IC,MISC:BIFET,ANALOG MUX;8 CHANNEL, 850 OHM , 1.6US;LF13508,DIP16.3	80009	156-1270-00
A72U4010	156-5001-00		IC,DIGITAL:LSTTL,GATES;QUAD 2-INPUT NAND;74 LS00,S014.150,TUBE	01295	SN74LS00D
A72U4015	156-5041-00		IC,DIGITAL:LSTTL,GATES;HEX INV BUS DRIVER, 3-STATE;74LS368,S016.150,TUBE	80009	156-5041-00
A72U4020	156-5034-00		IC,DIGITAL:LSTTL,BUFFER;NONINV, OCTAL, LINE DRIVER, 3-STATE;74LS244,S020.300,TUBE	80009	156-5034-00
A72U4030	156-5033-00		IC,DIGITAL:LSTTL,DEMUX/DECODER;3-TO-8 DECOD ER;74LS138,S016.150,TUBE	80009	156-5033-00
A72U4050	156-0512-00		IC,LINEAR:BIPOLAR,OP-AMP;LOW INPUT BIAS CUR RENT,UNCOMPENSATED;LM308N,DIP08.3	80009	156-0512-00
A72U4055	156-1249-00		IC,LINEAR:BIPOLAR,VOLTAGE REFERENCE;POSITIV E,10V,0.3%,30PPM,SERIES;AD581JH,TO-39	24355	AD40227
A72VR1053	152-5007-00		DIODE,ZENER.;,9.1V,5%,225MW;MMBZ5239BL,SOT- 23,8MM TR	80009	152-5007-00
A72VR1062	152-5007-00		DIODE,ZENER.;,9.1V,5%,225MW;MMBZ5239BL,SOT- 23,8MM TR	80009	152-5007-00

Replaceable Electrical Parts
494A/494AP Service Vol.2

Component No.	Tektronix Part No.	Serial/Assembly No. Effective	Dscont	Name & Description	Mfr. Code	Mfr. Part No.
A72VR4058	152-0127-00			DIODE, ZENER: ; 7.5V, 5%, 0.4W; 1N958B, DO-35 OR 7, TR	80009	152-0127-00
A74	670-5559-06	B010100	B010219	CIRCUIT BD ASSY:HIGH VOLTAGE	80009	670-5559-06
A74	670-5559-07	B010220		CIRCUIT BD ASSY:HIGH VOLTAGE	80009	670-5559-07
A74C1038	283-0177-00			CAP, FXD, CER DI: 1UF, +80-20%, 25V	04222	SR303E105ZAA
A74C1043	283-0208-00			CAP, FXD, CER DI: 0.22UF, 10%, 200V	04222	SR502C224KAA
A74C1058	283-0728-00			CAP, FXD, MICA DI: 120PF, 1%, 500V	80009	283-0728-00
A74C2084	290-0414-00			CAP, FXD, ELCTLT: 8UF, +50-10%, 200V	24165	600D805F200DE4
A74C3073	283-0197-00			CAP, FXD, CER DI: 470PF, 5%, 50V	05397	C320C471J5G5CA
A74C3076	283-0220-00	B010100	B010219	CAP, FXD, CER DI: 0.01UF, 20%, 50V	04222	SR205C103MAA
A74C3076	283-0167-00	B010220		CAP, FXD, CER DI: 0.1UF, 10%, 100V	80009	283-0167-00
A74C3086	283-0198-00			CAP, FXD, CER DI: 0.22UF, 20%, 50V	05397	C330C224M5U1CA
A74C3088	283-0198-00			CAP, FXD, CER DI: 0.22UF, 20%, 50V	05397	C330C224M5U1CA
A74C4072	283-0210-00			CAP, FXD, CER DI: 0.0056UF, 20%, 100V	04222	SR301C562MAA
A74CR1044	152-0107-03			DIODE, RECT: ; 400V, 1A, 10A IFSM; 1N4004, DO-41	04713	1N4004
A74CR1046	152-0242-00			DIODE, SIG: ; 225V, 200MA; FDH5004, DO-35, TR	07263	FDH5004
A74CR1047	152-0141-02			DIODE, SIG: ; ULTRA FAST; 40V, 150MA, 4NS, 2PF; 1N4152, DO-35, T&R	80009	152-0141-02
A74CR1048	152-0141-02			DIODE, SIG: ; ULTRA FAST; 40V, 150MA, 4NS, 2PF; 1N4152, DO-35, T&R	80009	152-0141-02
A74CR1056	152-0242-00			DIODE, SIG: ; 225V, 200MA; FDH5004, DO-35, TR	07263	FDH5004
A74CR1079	152-0107-03			DIODE, RECT: ; 400V, 1A, 10A IFSM; 1N4004, DO-41	04713	1N4004
A74CR1086	152-0400-00			DIODE, RECT: ; FAST RCVR; 400V, 1A, 200NS; 1N4936, DO-41, T&R	80009	152-0400-00
A74CR2044	152-0242-00			DIODE, SIG: ; 225V, 200MA; FDH5004, DO-35, TR	07263	FDH5004
A74CR2046	152-0242-00			DIODE, SIG: ; 225V, 200MA; FDH5004, DO-35, TR	07263	FDH5004
A74CR3077	152-0141-02			DIODE, SIG: ; ULTRA FAST; 40V, 150MA, 4NS, 2PF; 1N4152, DO-35, T&R	80009	152-0141-02
A74CR4071	152-0141-02			DIODE, SIG: ; ULTRA FAST; 40V, 150MA, 4NS, 2PF; 1N4152, DO-35, T&R	80009	152-0141-02
A74CR4077	152-0141-02			DIODE, SIG: ; ULTRA FAST; 40V, 150MA, 4NS, 2PF; 1N4152, DO-35, T&R	80009	152-0141-02
A74CR4078	152-0141-02			DIODE, SIG: ; ULTRA FAST; 40V, 150MA, 4NS, 2PF; 1N4152, DO-35, T&R	80009	152-0141-02
A74Q1073	151-0423-00			TRANSISTOR, PWR: BIPOLAR, NPN; 400V, 1.0A, SWITCH ING; 2SC2333L/TIP50, TO-220	80009	151-0423-00
A74Q2048	151-0443-00			TRANSISTOR, SIG: BIPOLAR, PNP; 300V, 500MA, 50MHZ, AMPLIFIER; MPSA92, TO-92 EBC	80009	151-0443-00
A74R151	315-0334-00			RES, FXD, FILM: 330K OHM, 5%, 0.25W	80009	315-0334-00
A74R1042	315-0102-00			RES, FXD, FILM: 1K OHM, 5%, 0.25W	80009	315-0102-00
A74R1043	301-0472-00			RES, FXD, FILM: 4.7K OHM, 5%, 0.5W	80009	301-0472-00
A74R1048	315-0224-00			RES, FXD, FILM: 220K OHM, 5%, 0.25W	80009	315-0224-00
A74R2012	308-0581-00			RES, FXD, WW: 4.75 OHM, 0.5%, 0.5W	07088	KM050 4R7500
A74R2040	311-1287-00			RES, VAR, NONWW: TRMR, 100K OHM, 0.5W	80009	311-1287-00
A74R2050	315-0104-00			RES, FXD, FILM: 100K OHM, 5%, 0.25W	80009	315-0104-00
A74R3033	311-1968-00			RES, VAR, NONWW: PNL, 5M OHM, 20%, 0.5W	80009	311-1968-00
A74R3071	315-0431-00	B010100	B010219	RES, FXD, FILM: 430 OHM, 5%, 0.25W	80009	315-0431-00
A74R3071	315-0221-00	B010220		RES, FXD, FILM: 220 OHM, 5%, 0.25W	80009	315-0221-00
A74R3072	315-0512-00	B010100	B010219	RES, FXD, FILM: 5.1K OHM, 5%, 0.25W	80009	315-0512-00
A74R3072	315-0392-00	B010220		RES, FXD, FILM: 3.9K OHM, 5%, 0.25W	80009	315-0392-00
A74R3074	315-0105-00			RES, FXD, FILM: 1M OHM, 5%, 0.25W	80009	315-0105-00
A74R3075	315-0222-00			RES, FXD, FILM: 2.2K OHM, 5%, 0.25W	80009	315-0222-00
A74R3078	315-0133-00			RES, FXD, FILM: 13K OHM, 5%, 0.25W	80009	315-0133-00
A74R3079	315-0184-00			RES, FXD, FILM: 180K OHM, 5%, 0.25W	80009	315-0184-00
A74R4038	315-0102-00			RES, FXD, FILM: 1K OHM, 5%, 0.25W	80009	315-0102-00
A74R4074	315-0473-00			RES, FXD, FILM: 47K OHM, 5%, 0.25W	80009	315-0473-00
A74R4075	315-0102-00			RES, FXD, FILM: 1K OHM, 5%, 0.25W	80009	315-0102-00
A74T2065	120-1233-00			XFMR, PWR, SDN&SU: HIGH VOLTAGE	80009	120-1233-00

Replaceable Electrical Parts
494A/494AP Service Vol.2

Component No.	Tektronix Part No.	Serial/Assembly No. Effective	Discort	Name & Description	Mfr. Code	Mfr. Part No.
A74U4083	156-0067-00			IC, LINEAR: BIPOLAR, OP-AMP; ;741C, DIP08, 3	80009	156-0067-00
A74VR1041	152-0283-00			DIODE, ZENER: ; ;43V, 5%, 0.4W; 1N976B, DO-7 OR 35	04713	1N976B
A74A1	-----			, TR (PART OF A74)		
A77	670-5746-01			CIRCUIT BD ASSY: CRT GRATICULE LIGHT	80009	670-5746-01
A77DS1011	150-0029-00			LAMP, INCAND: 6.3V, 0.2A, #349, MIDGET FLG	58854	349
A77DS1013	150-0029-00			LAMP, INCAND: 6.3V, 0.2A, #349, MIDGET FLG	58854	349
A77P770	131-0592-00			TERMINAL, PIN:	80009	131-0592-00
F301	159-0017-00			FUSE, CARTRIDGE: 3AG, 4A, 250V, FAST BLOW	71400	AGC-4
F301	159-0023-00			FUSE, CARTRIDGE: 3AG, 2A, 250V, SLOW BLOW (OPTIONS A1, A2, A3, A4, A5 ONLY)	71400	MXZ2
FL10	119-0294-01			FILTER, LOW PASS: DC TO 1.8GHZ	50140	119-250-X1800-0
FL11	119-1752-00			FLTR CA ASSY, RF: 50 OHM COAX, 7.12 L, SEMI-RGD	80009	119-1752-00
FL12	119-2048-00			FLTR, YIG TUNED:	80009	119-2048-00
FL15	119-1753-00			FLTR CA ASSY, RF: 50 OHM COAX, 7.14 L, SEMI-RGD	80009	119-1753-00
FL16	119-1018-00			DIR FILTER ASSY:	80009	119-1018-00
FL36	119-2403-00			FILTER, BANDPASS: 110MHZ	80009	119-2403-00
FL37	119-2414-00			FILTER, LOW PASS: 110 MHZ	80009	119-2414-00
FL680	119-2033-00			FILTER, CRYSTAL: 100HZ BW, 10MHZ CF	34630	001-43360
P133	015-1022-00			TERMN, COAXIAL: 50 OHM, 0.5W, SMA	80009	015-1022-00
P144	015-1022-00			TERMN, COAXIAL: 50 OHM, 0.5W, SMA	80009	015-1022-00
P145	015-1022-00			TERMN, COAXIAL: 50 OHM, 0.5W, SMA	80009	015-1022-00
P164	015-1022-00			TERMN, COAXIAL: 50 OHM, 0.5W, SMA	80009	015-1022-00
P222	131-0938-00			CONN, RF JACK: ; SMB/PNL. ; MALE, STR, 50 OHM, 0.25 HEX, 2.0 L 0.025 DIA TAIL, 10-32 THD, REAR MT	24931	32JRI25-1
P620	131-0372-00			CONN, RF PLUG:	80009	131-0372-00
P621	131-0372-00			CONN, RF PLUG:	80009	131-0372-00
P800	015-1025-01	B010100	B010323	TERMN, COAXIAL: 3MM MALE 50OHM W/CH	80009	015-1025-01
P800	015-1022-00	B010324		TERMN, COAXIAL: 50 OHM, 0.5W, SMA	80009	015-1022-00
P900	015-1025-01	B010100	B010323	TERMN, COAXIAL: 3MM MALE 50OHM W/CH	80009	015-1025-01
P900	015-1022-00	B010324		TERMN, COAXIAL: 50 OHM, 0.5W, SMA	80009	015-1022-00
S11	119-1161-01			SW, RF XMSN LINE: DC TO 21GHZ, 60 DB ISOLATION , COAXIAL SPDT, 50 OHM, 3MM	80009	119-1161-01
S12	119-1161-01			SW, RF XMSN LINE: DC TO 21GHZ, 60 DB ISOLATION , COAXIAL SPDT, 50 OHM, 3MM	80009	119-1161-01
S13	119-1161-01			SW, RF XMSN LINE: DC TO 21GHZ, 60 DB ISOLATION , COAXIAL SPDT, 50 OHM, 3MM	80009	119-1161-01
T200	120-1545-00			TRANSFORMER, RF: 75 OHM BNC INPUT/50 OHM SMA OUTPUT (OPTION 07 ONLY)	98821	NH-12296
V100	154-0910-00			ELECTRON TUBE: CRT, P31, A284C	80009	154-0910-00
W100	175-7400-01			CABLE ASSY, RF: 50 OHM COAX, MW SWITCH TO ATTE NUATOR, SEMI-RIGID	80009	175-7400-01
W101	175-7401-02			CABLE ASSY, RF: 50 OHM COAX, RF CONNECTOR TO A TTENUATOR, SEMI-RIGID	80009	175-7401-02
W102	175-9262-00			CABLE ASSY, RF: 50 OHM COAX, 4.224 L	80009	175-9262-00
W104	175-9261-00			CABLE ASSY, RF: 50 OHM COAX, 7.572 L	80009	175-9261-00
W106	175-9582-00			CABLE ASSY, RF: 50 OHM COAX, 2.82 L	80009	175-9582-00
W112	175-7403-01			CABLE ASSY, RF: 50 OHM COAX, 1.949 L, SEMI RIGI D	80009	175-7403-01
W114	175-2530-02			CABLE ASSY, RF: 50 OHM COAX, 6.34 L	80009	175-2530-02
W116	175-9263-00			CABLE ASSY, RF: 50 OHM COAX, 2.94 L	80009	175-9263-00
W117	174-0924-00	B010220		CABLE ASSY, RF: 50 OHM COAX	80009	174-0924-00
W118	175-2761-02	B010100	B010219	CABLE ASSY, RF: 50 OHM COAX, 3.63 L	80009	175-2761-02
W124	175-2542-02			CABLE ASSY, RF: 50 OHM COAX, 2.62 L	80009	175-2542-02
W125	175-3024-03			CABLE ASSY, RF: 50 OHM COAX, 6.89 L (OPTION 07 & 08 ONLY)	80009	175-3024-03

Replaceable Electrical Parts
494A/494AP Service Vol.2

Component No.	Tektronix		Serial/Assembly No.		Name & Description	Mfr. Code	Mfr. Part No.
	Part No.		Effective	Dscont			
W126	175-7402-01				CABLE ASSY,RF:50 OHM COAX,1.737 L,SEMI-RIGI D	80009	175-7402-01
W130	175-2345-00				CABLE ASSY,RF:50 OHM COAX,10.29 L	80009	175-2345-00
W132	175-2762-02				CABLE ASSY,RF:50 OHM COAX,17.56 L	80009	175-2762-02
W137	175-9196-01				CABLE ASSY,RF:50 OHM COAX,W/O JKT,SEMI RIGI D,TRANS SWC TO EXT MIX	80009	175-9196-01
W138	175-2541-02				CABLE ASSY,RF:50 OHM COAX,6.1 L	80009	175-2541-02
W162	175-2337-02				CABLE ASSY,RF:50 OHM COAX,3.497 L	80009	175-2337-02
W164	175-7399-01				CABLE ASSY,RF:50 OHM COAX,DIR FILTER TO DIP LEXER IN,SEMI-RIGID	80009	175-7399-01
W166	175-2763-00				CABLE ASSY,RF:50 OHM COAX,3.13 L	80009	175-2763-00
W182	175-2406-00				CABLE ASSY,RF:50 OHM COAX,3.0 L	TK2469	175-2406-00
W190	175-2415-00				CABLE ASSY,RF:50 OHM COAX,7.0 L (OPTION 42 ONLY)	TK2469	175-2415-00
W191	175-2415-00				CABLE ASSY,RF:50 OHM COAX,7.0 L (OPTION 42 ONLY)	TK2469	175-2415-00
W220	175-4542-00				CABLE ASSY,RF:50 OHM COAX,8.9 L,SEMIRIGID	80009	175-4542-00
W224	175-7601-00				CABLE ASSY,RF:50 OHM COAX,20.35 L	TK1375	175-7601-00
W232	175-2407-00				CABLE ASSY,RF:50 OHM COAX,5.0 L	TK2469	175-2407-00
W236	175-9195-01				CABLE ASSY,RF:50 OHM COAX SEMI-RIGID	80009	175-9195-01
W240	175-7397-00				CABLE ASSY,RF:50 OHM COAX,HARMONIC MIXER TO PHASE GATE,SEMI RIGID	80009	175-7397-00
W250	175-7398-00				CABLE ASSY,RF:50 OHM COAX,HARMONIC MIXER TO BIAS RETURN,SEMI RIGID	80009	175-7398-00
W252	175-7602-00				CABLE ASSY,RF:50 OHM COAX,18.35 L	TK1375	175-7602-00
W260	175-7600-00				CABLE ASSY,RF:50 OHM COAX,20.35 L	TK1375	175-7600-00
W320	175-2406-00				CABLE ASSY,RF:50 OHM COAX,3.0 L	TK2469	175-2406-00
W340	175-9254-00				CABLE ASSY,RF:50 OHM COAX,17.52 L	87473	175-9254-00
W341	175-2409-00				CABLE ASSY,RF:50 OHM COAX,8.0 L (OPTION 07 ONLY)	TK2469	175-2409-00
W342	175-2413-00				CABLE ASSY,RF:50 OHM COAX,13.0 L	TK2469	175-2413-00
W344	175-2411-00				CABLE ASSY,RF:50 OHM COAX,17.0 L	TK2469	175-2411-00
W346	175-2409-00				CABLE ASSY,RF:50 OHM COAX,8.0 L	TK2469	175-2409-00
W347	175-7597-00				CABLE ASSY,RF:50 OHM COAX,18.25 L	TK1375	175-7597-00
W348	175-2410-00				CABLE ASSY,RF:50 OHM COAX,10.0 L	TK2469	175-2410-00
W350	175-8962-00				CABLE ASSY,RF:50 OHM COAX,14.46 L,POLTHN JK T	TK1375	175-8962-00
W360	175-2418-00				CABLE ASSY,RF:50 OHM COAX,2.5 L	TK2469	175-2418-00
W361	175-7594-00				CABLE ASSY,RF:50 OHM COAX,3.25 L	TK1375	175-7594-00
W370	175-2402-00				CABLE ASSY,RF:50 OHM COAX,12.0 L	TK2469	175-2402-00
W502	175-2402-00				CABLE ASSY,RF:50 OHM COAX,12.0 L	TK2469	175-2402-00
W622	175-7788-00				CABLE ASSY,RF:50 OHM,COAX,8.25 L	TK1375	175-7788-00
W682	175-2418-00				CABLE ASSY,RF:50 OHM COAX,2.5 L	TK2469	175-2418-00
W684	175-2415-00				CABLE ASSY,RF:50 OHM COAX,7.0 L	TK2469	175-2415-00
W694	174-0705-00	B010100	B010221		CABLE ASSY,RF:50 OHM COAX,11.0 L	80009	174-0705-00
W694	175-2409-00	B010222			CABLE ASSY,RF:50 OHM COAX,8.0 L	TK2469	175-2409-00
W700	175-9293-01				CABLE ASSY,RF:75 OHM COAX INPUT (OPTION 07 ONLY)	80009	175-9293-01
W701	175-9295-02				CABLE ASSY,RF:TRANS SW TO ATTN (OPTION 07 ONLY)	80009	175-9295-02
W702	175-9296-01				CABLE ASSY,RF:50 OHM COAX RF INPUT (OPTION 07 ONLY)	80009	175-9296-01
W703	175-2412-00				CABLE ASSY,RF:50 OHM COAX,12.0 L (OPTION 07 ONLY)	TK2469	175-2412-00
W1025	175-2372-00				CABLE ASSY,RF:50 OHM COAX,3.26 AWG,5.0 L	TK1375	175-2372-00
W1037	198-4424-00				WIRE SET,ELEC:	80009	198-4424-00
W1038	175-0863-00				CABLE,SP,ELEC:RBN.;2,22 AWG,7-30 STRAND,UL1 061,300V/80 DEG C,PVC,TIN TOPCOAT,BRN,RED,1 .2;..	TK0846	02CF2M7-BBT

Replaceable Electrical Parts
494A/494AP Service Vol.2

Component No.	Tektronix	Serial/Assembly No.		Name & Description	Mfr.	Mfr. Part No.
	Part No.	Effective	Dscont		Code	
W1044	175-7789-00			CABLE ASSY,RF:50 OHM COAX,15.25 L	TK1375	175-7789-00
W1060	175-7598-00			CABLE ASSY,RF:50 OHM COAX,13.25 L	TK1375	175-7598-00

DIAGRAMS AND CIRCUIT BOARD ILLUSTRATIONS

Symbols

Graphic symbols and class designation letters are based on ANSI Standard Y32.2-1975.

Logic symbols are based on ANSI/IEEE 91-1984. Logic symbols show the logic function performed and may differ from the manufacturer's data.

Abbreviations are based on ANSI Y1.1-1972.

Other ANSI standards used in diagrams are:

- Y14.15-1966 Drafting Practices.
- Y14.2-1973 Line Conventions and Lettering.
- Y10.5-1975 Letter Symbols for Quantities Used in Electrical Science and Electrical Engineering.

American National Standard Institute
1430 Broadway
New York, New York 10018

Component Values

Electrical components shown on the diagrams are in the following units unless noted otherwise:

Capacitors = Values one or greater are in picofarads (pF). Values less than one are in microfarads (μ F).

Resistors = Ohms (Ω).

Assembly and Circuit Numbering

Each assembly and subassembly are assigned assembly numbers. The assembly number appears on the circuit board outline on the diagram, in the title for the circuit board illustration, and in the corresponding lookup table.

The Replaceable Electrical Parts list prefixes the circuit numbers with the corresponding assembly and subassembly numbers.

EXAMPLE: R2080 on assembly A20 becomes A20R2080.

EXAMPLE: U1044 on subassembly A1 of assembly A36 is found in the electrical parts list as A36A1U1044.

Grid Coordinates

The schematic diagrams and circuit board illustrations are labeled with horizontal and vertical grids. Lookup tables with the grid coordinates are provided as a cross reference to help locate components on the corresponding schematic and circuit board.

Sample Diagram

The following sample diagram labels various details found on schematic diagrams.

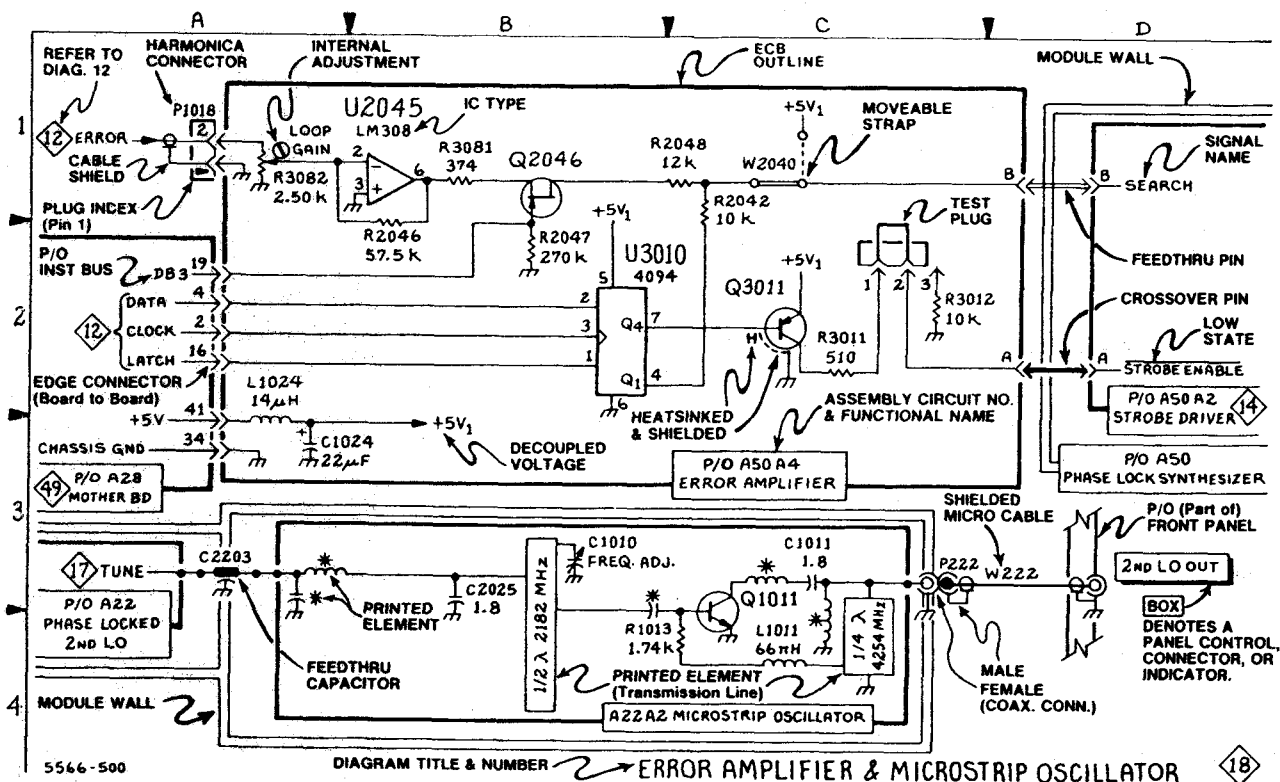

5566-500

DIAGRAM TITLE & NUMBER → ERROR AMPLIFIER & MICROSTRIP OSCILLATOR

18

Schematic Diagram

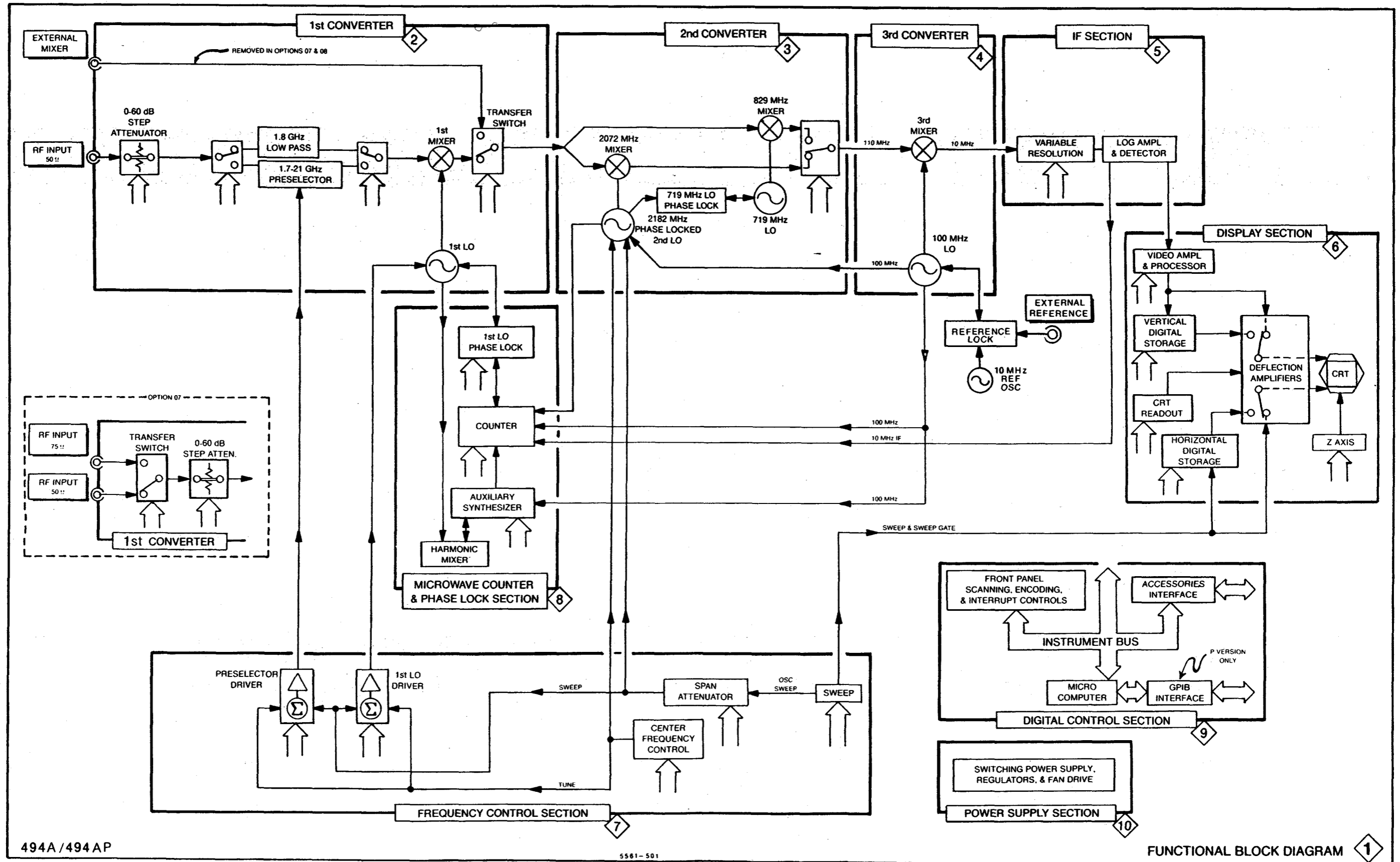

494A/494AP

5561-501

FUNCTIONAL BLOCK DIAGRAM

1

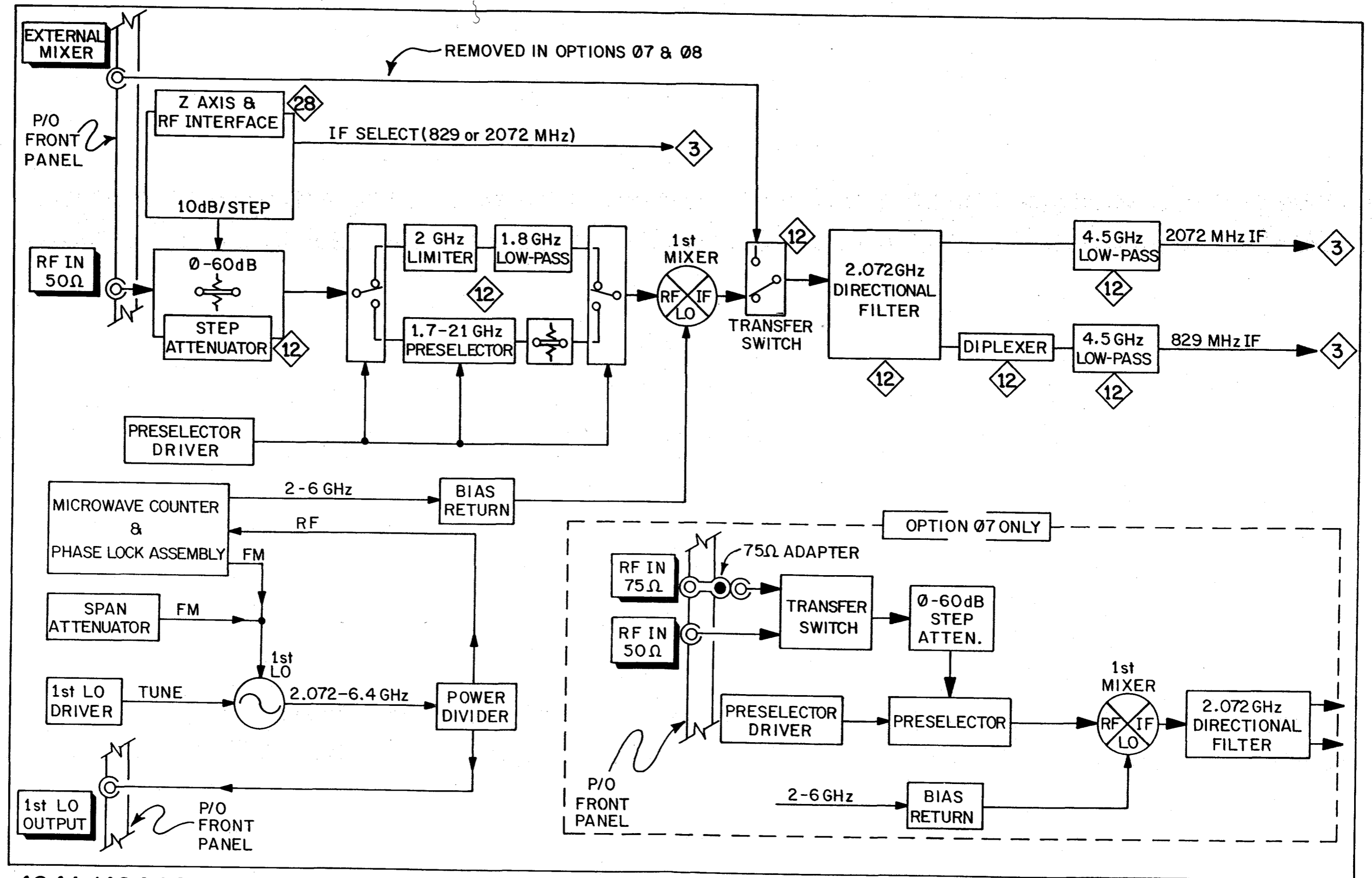

494A/494 AP

5561-502

1st CONVERTER BLOCK DIAGRAM 2

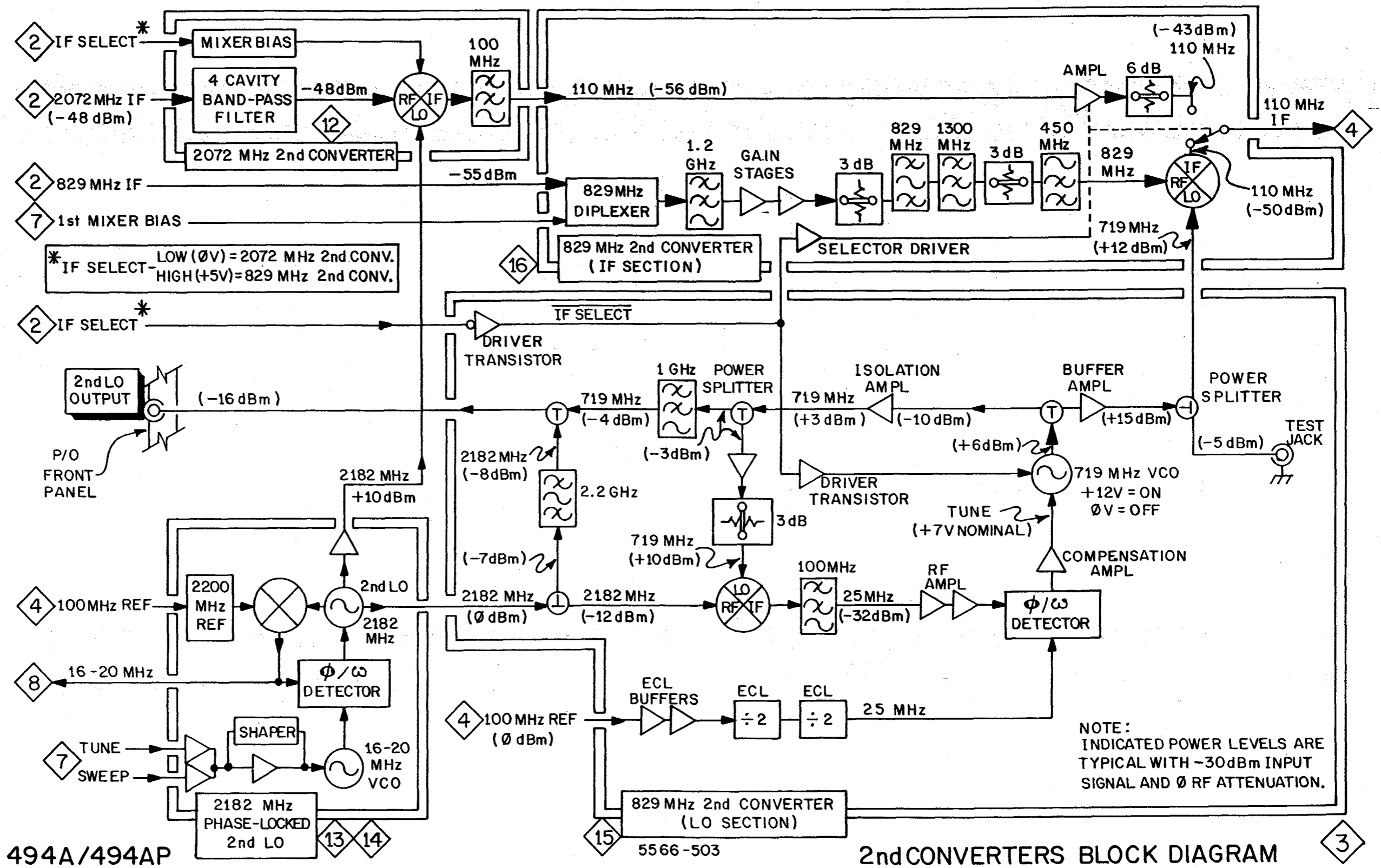

NOTE: INDICATED POWER LEVELS ARE TYPICAL WITH -30dBm INPUT SIGNAL AND 0 RF ATTENUATION.

494A/494AP

2nd CONVERTERS BLOCK DIAGRAM

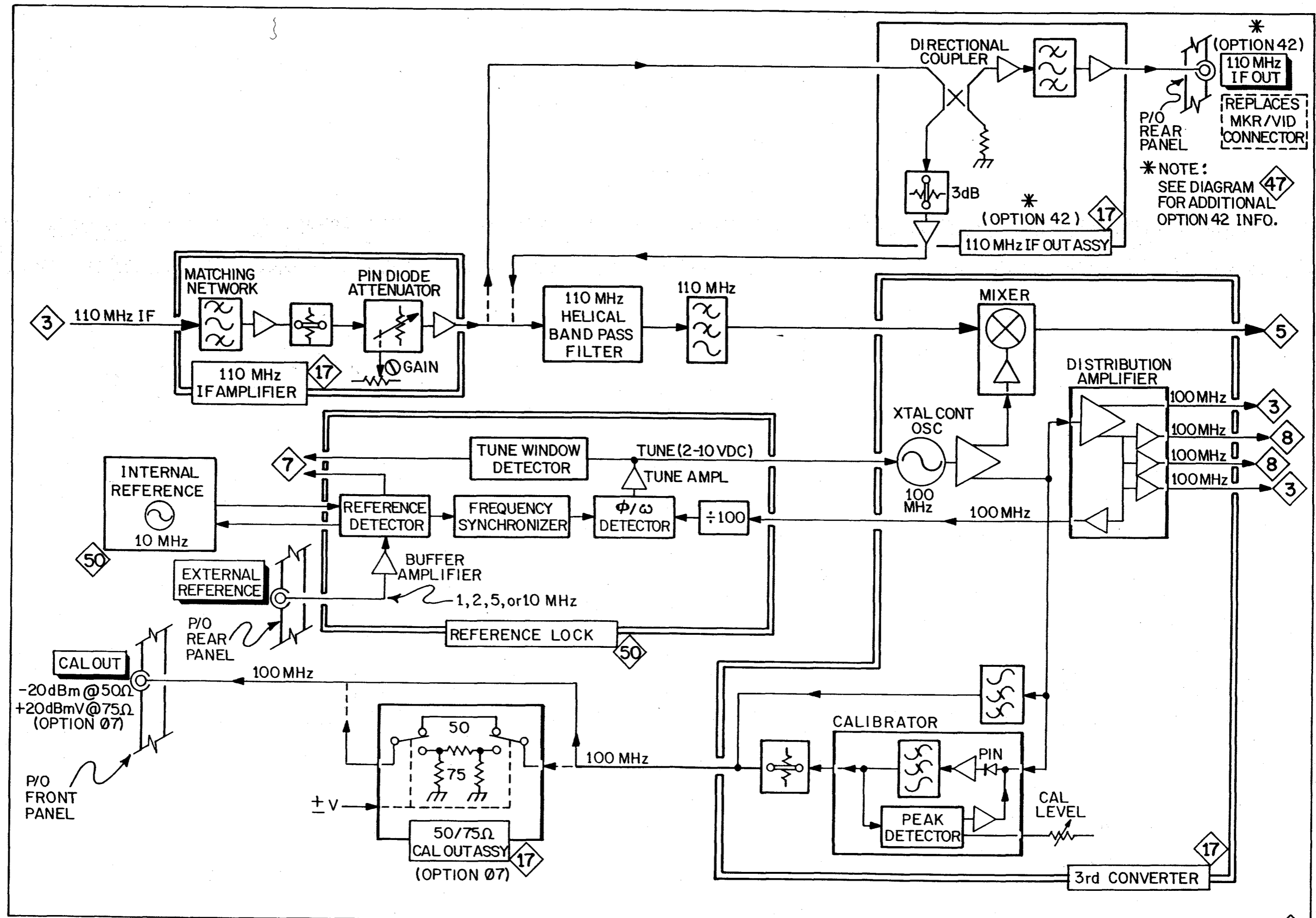

* (OPTION 42)
 110 MHz IF OUT
 REPLACES MKR/VID CONNECTOR!
 P/O REAR PANEL
 * NOTE: SEE DIAGRAM 47 FOR ADDITIONAL OPTION 42 INFO.

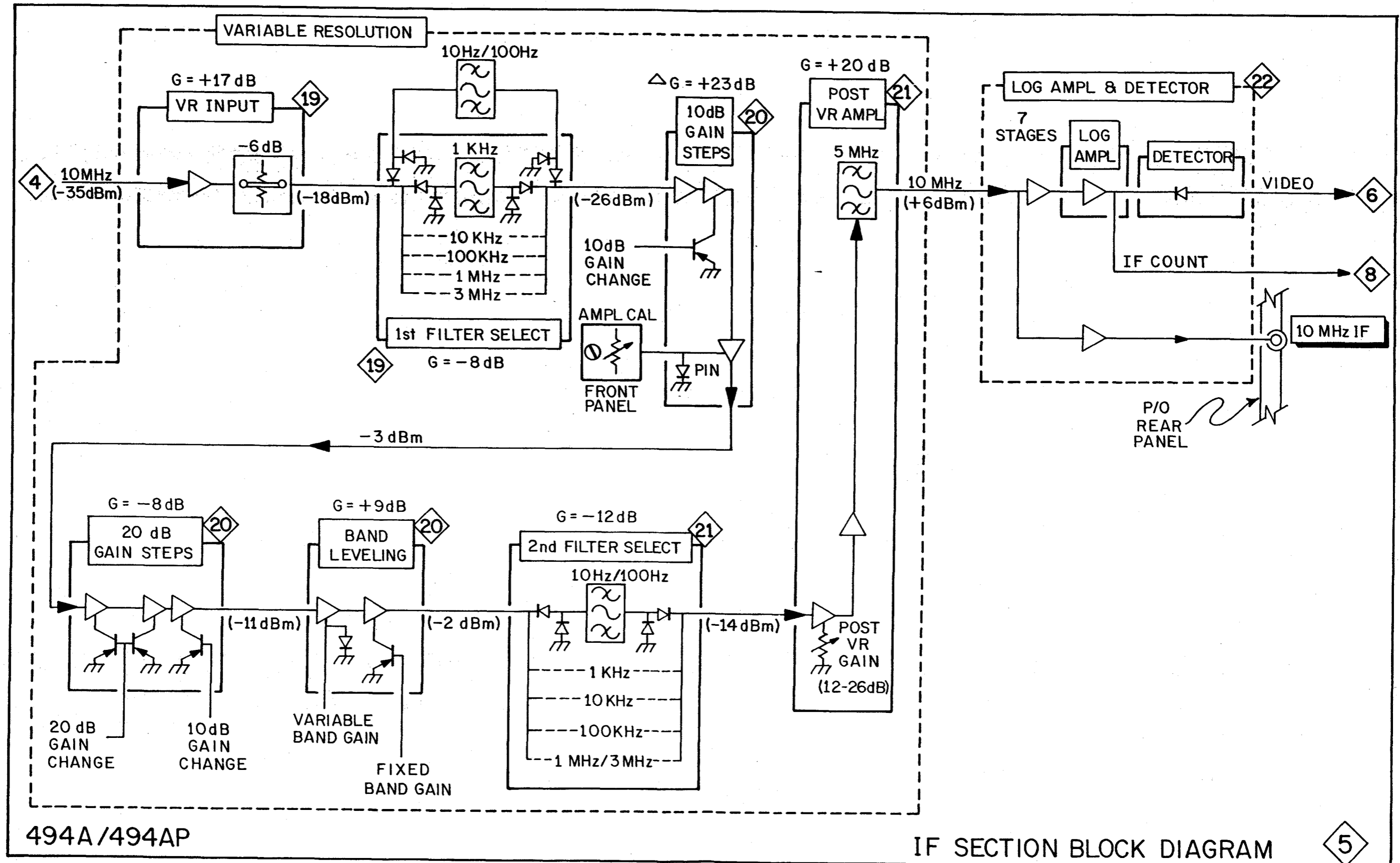

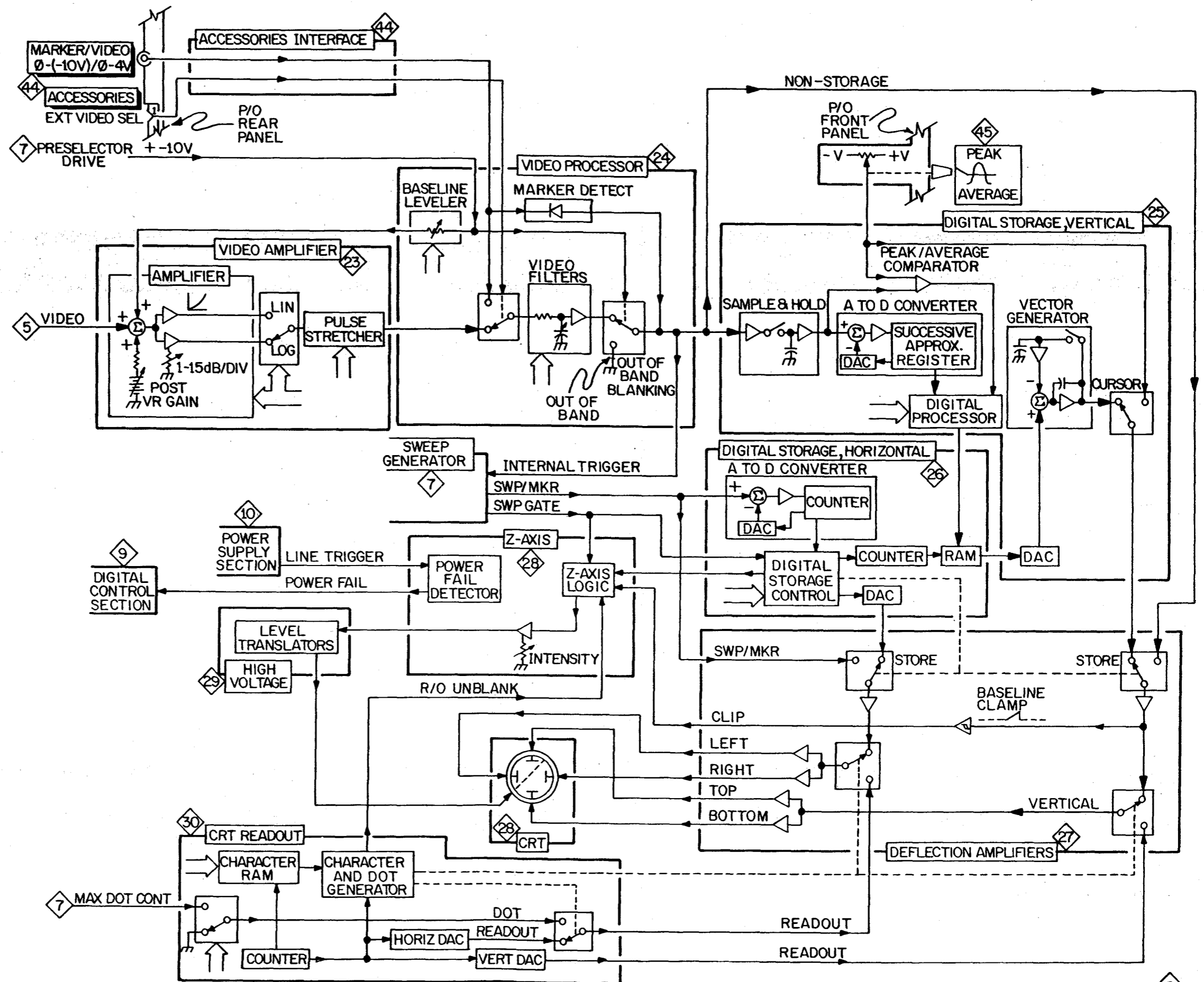

494A/494AP

5566-506

DISPLAY CONTROL SECTION BLOCK DIAGRAM

6

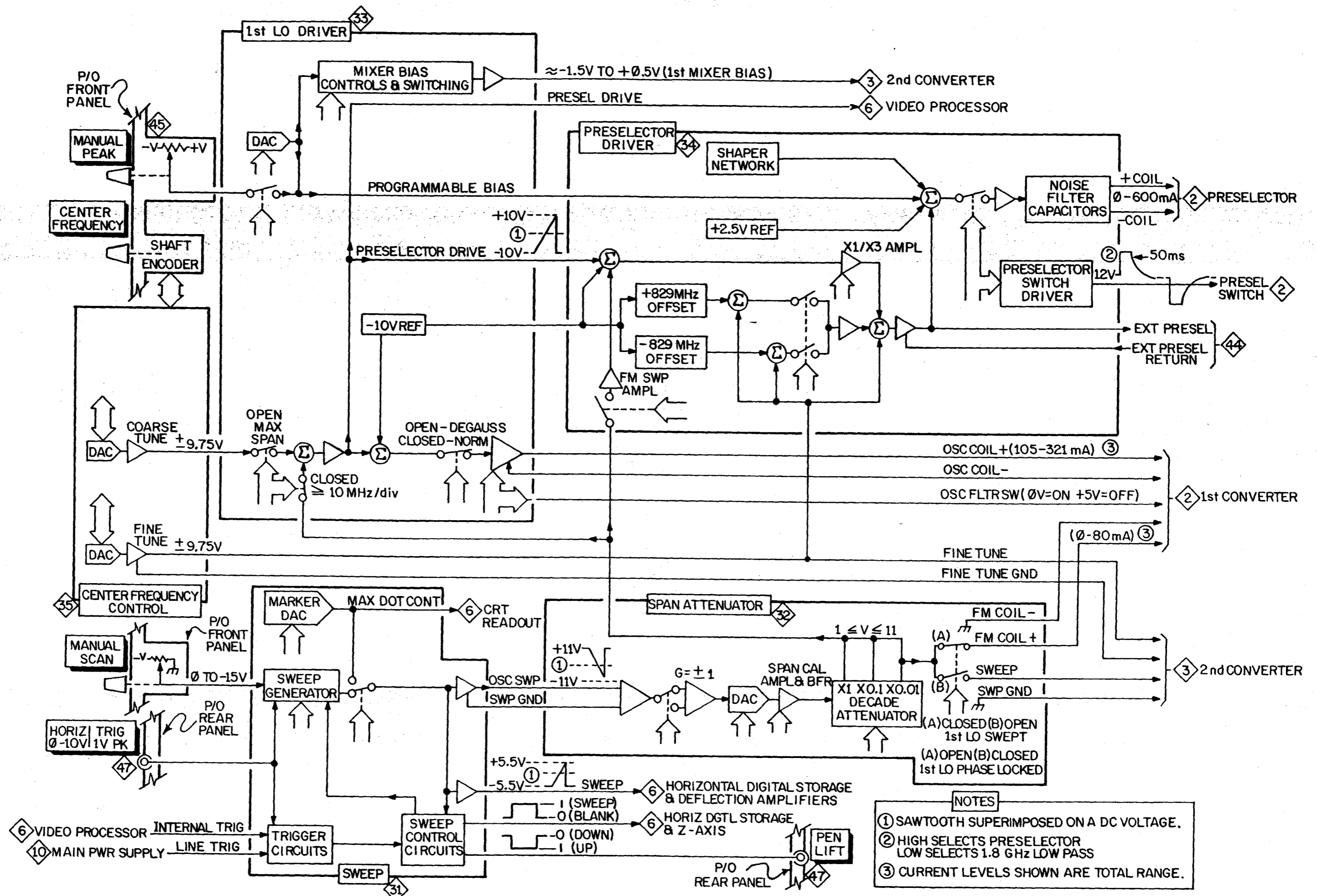

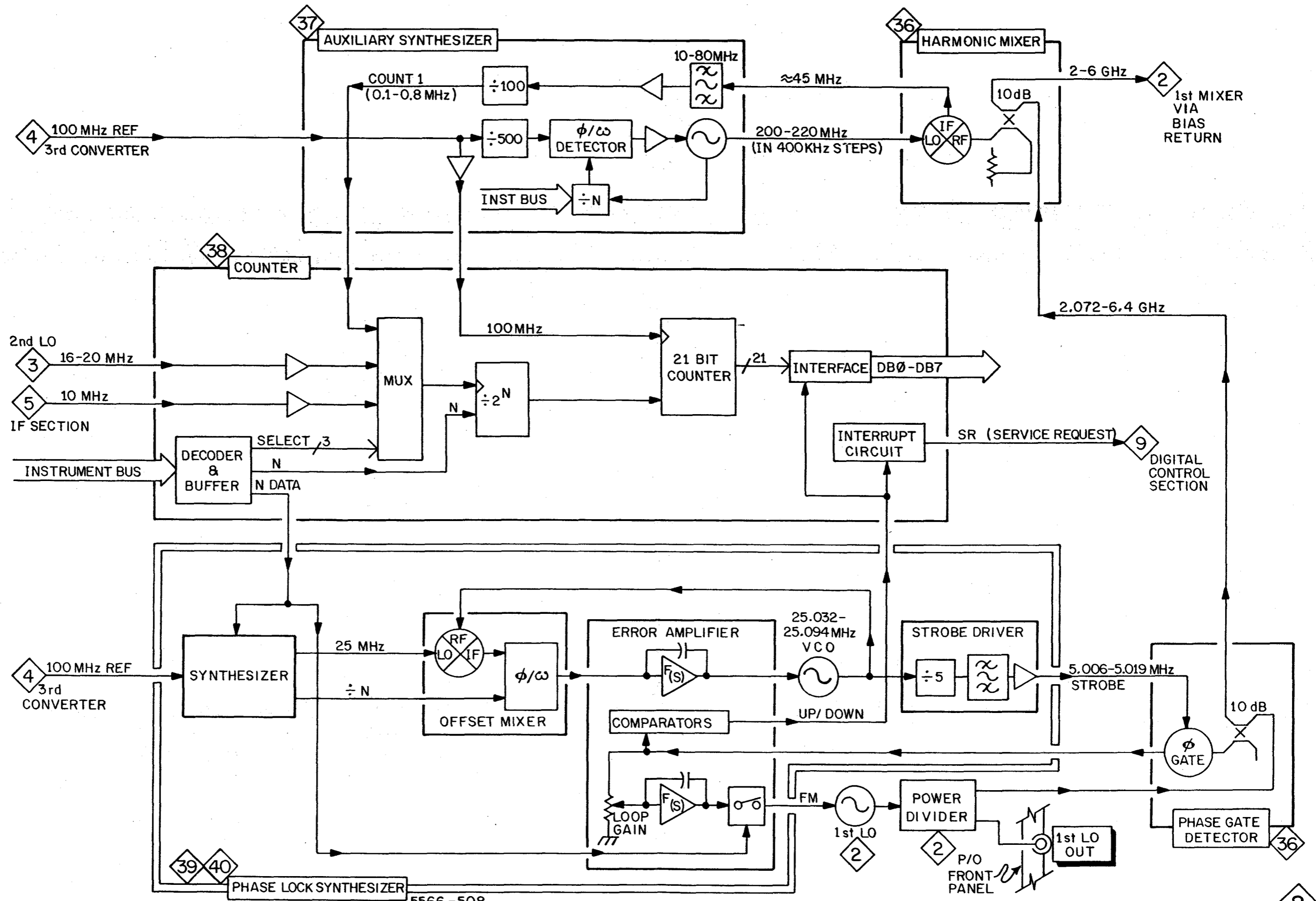

494A/494AP

COUNTER & PHASE LOCK SECTION BLOCK DIAGRAM

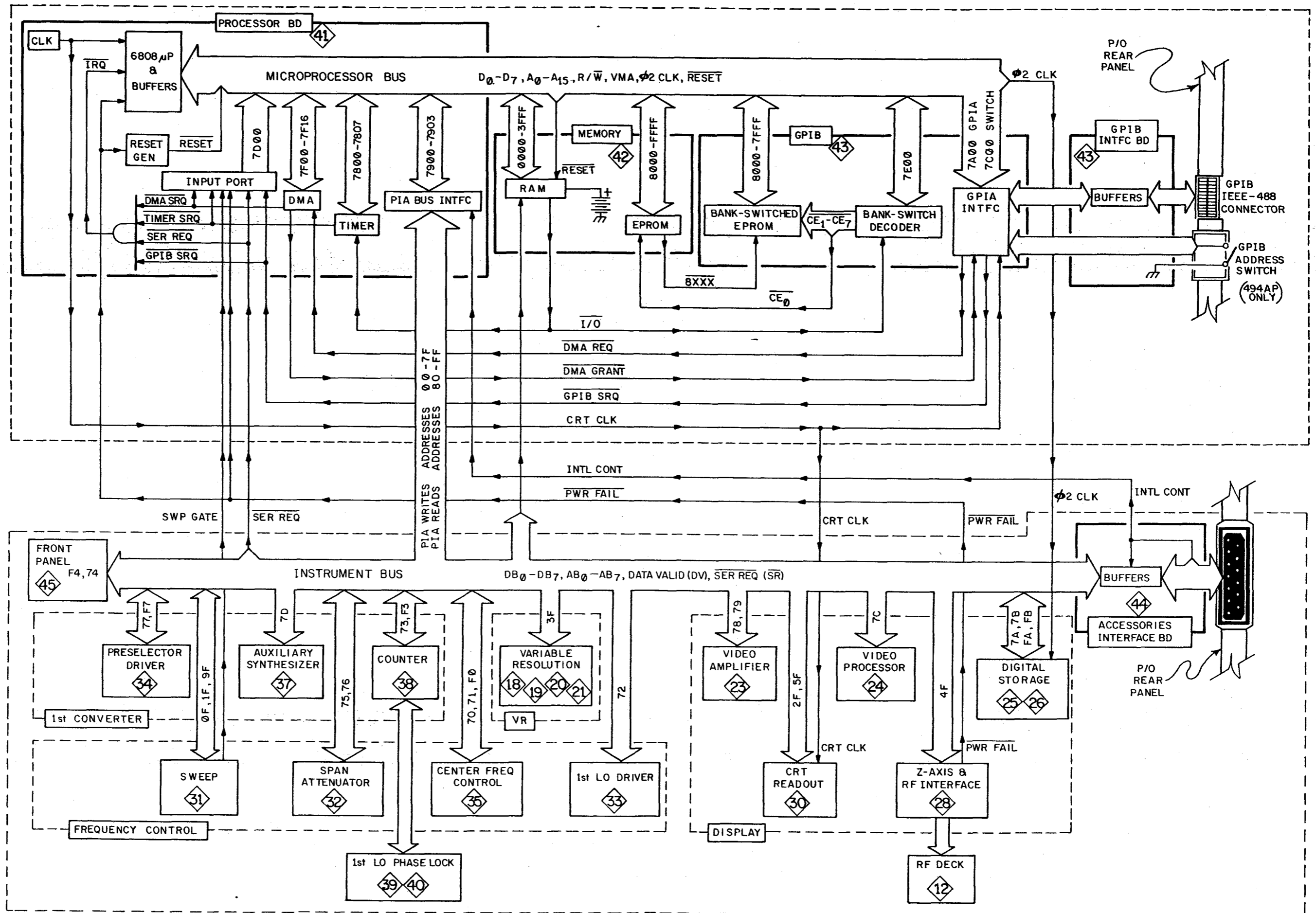

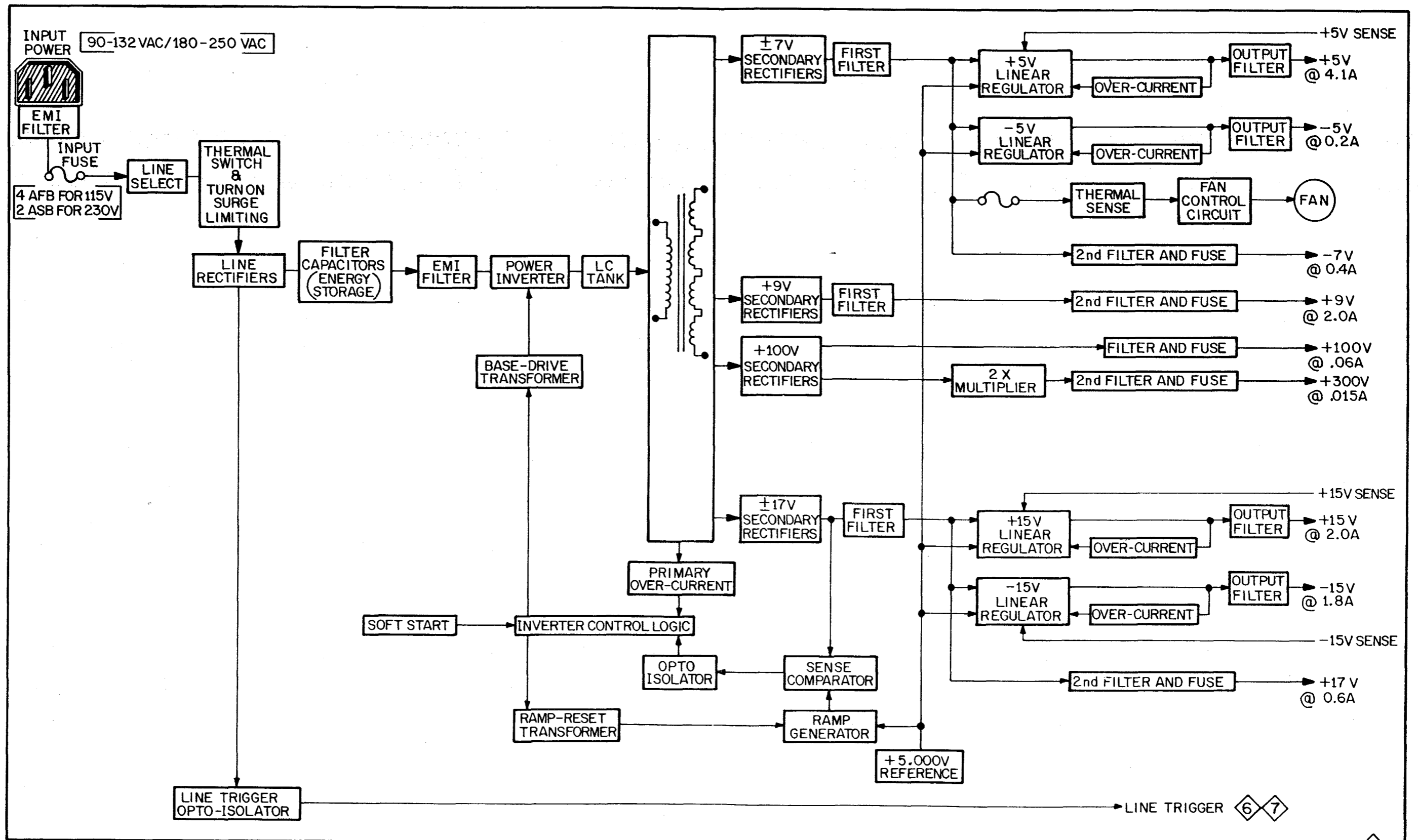

494A/494AP

5566-510

POWER SUPPLY SECTION BLOCK DIAGRAM

10

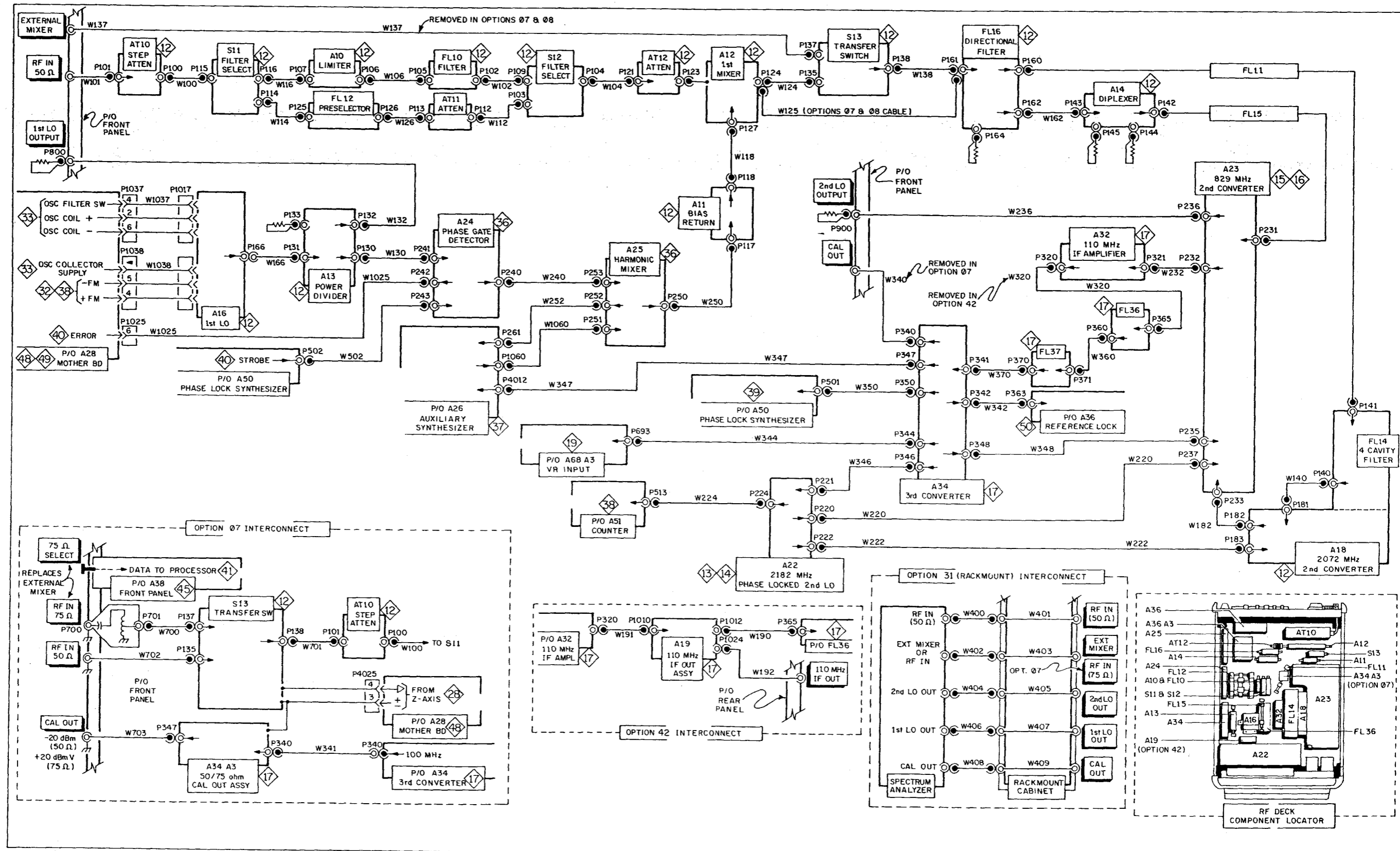

494A/494AP

5561-511

RF DECK INTERCONNECT

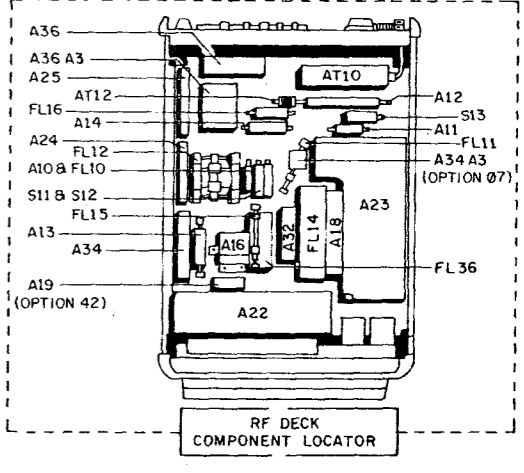

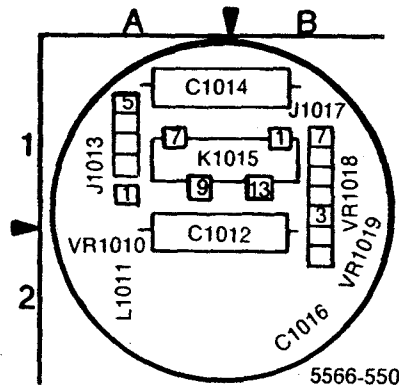

Figure 10-1. A16A1—1st LO Interface circuit board.

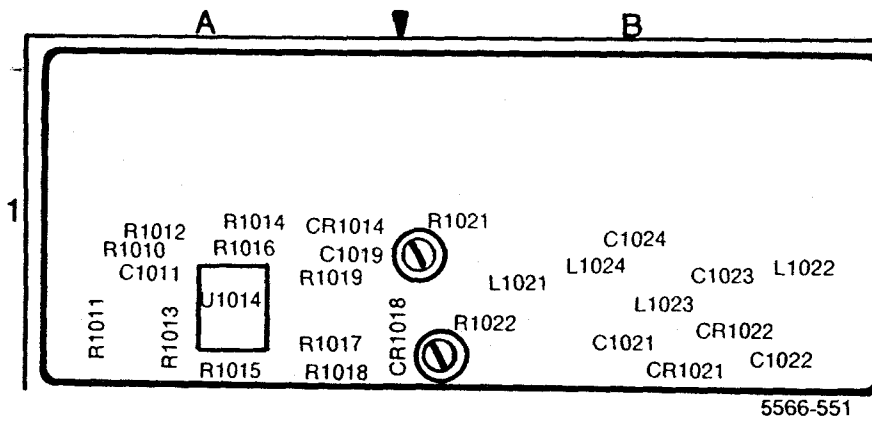
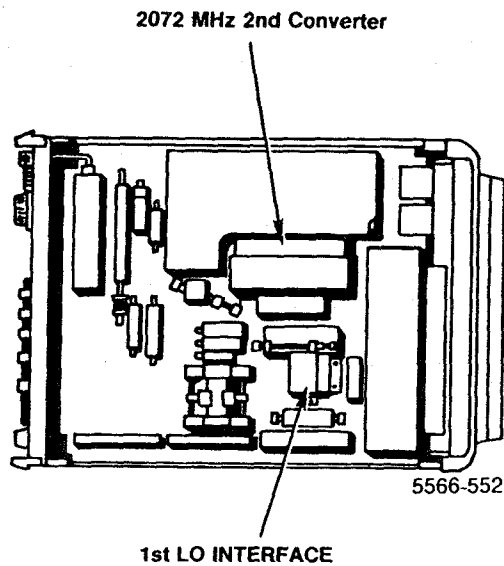
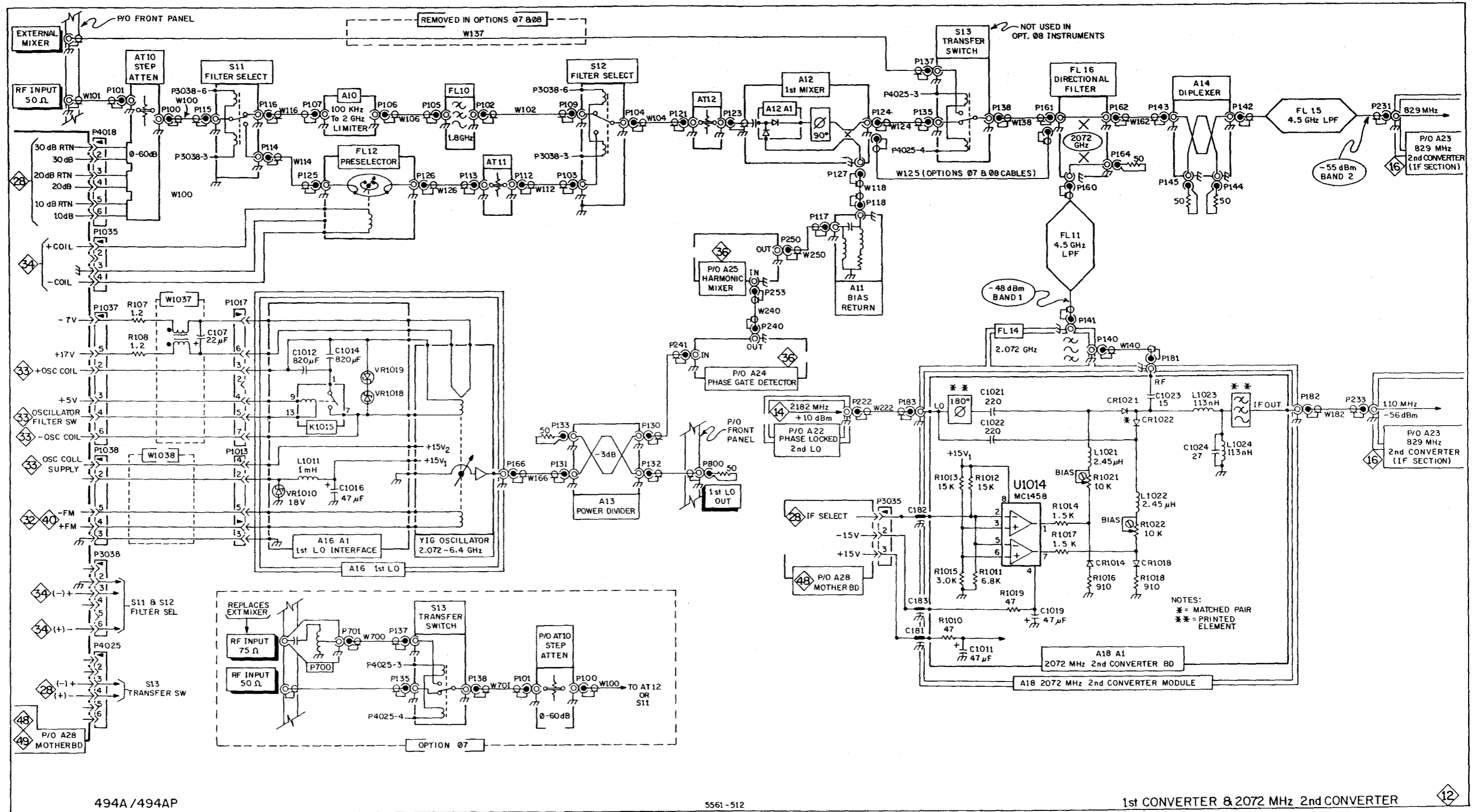
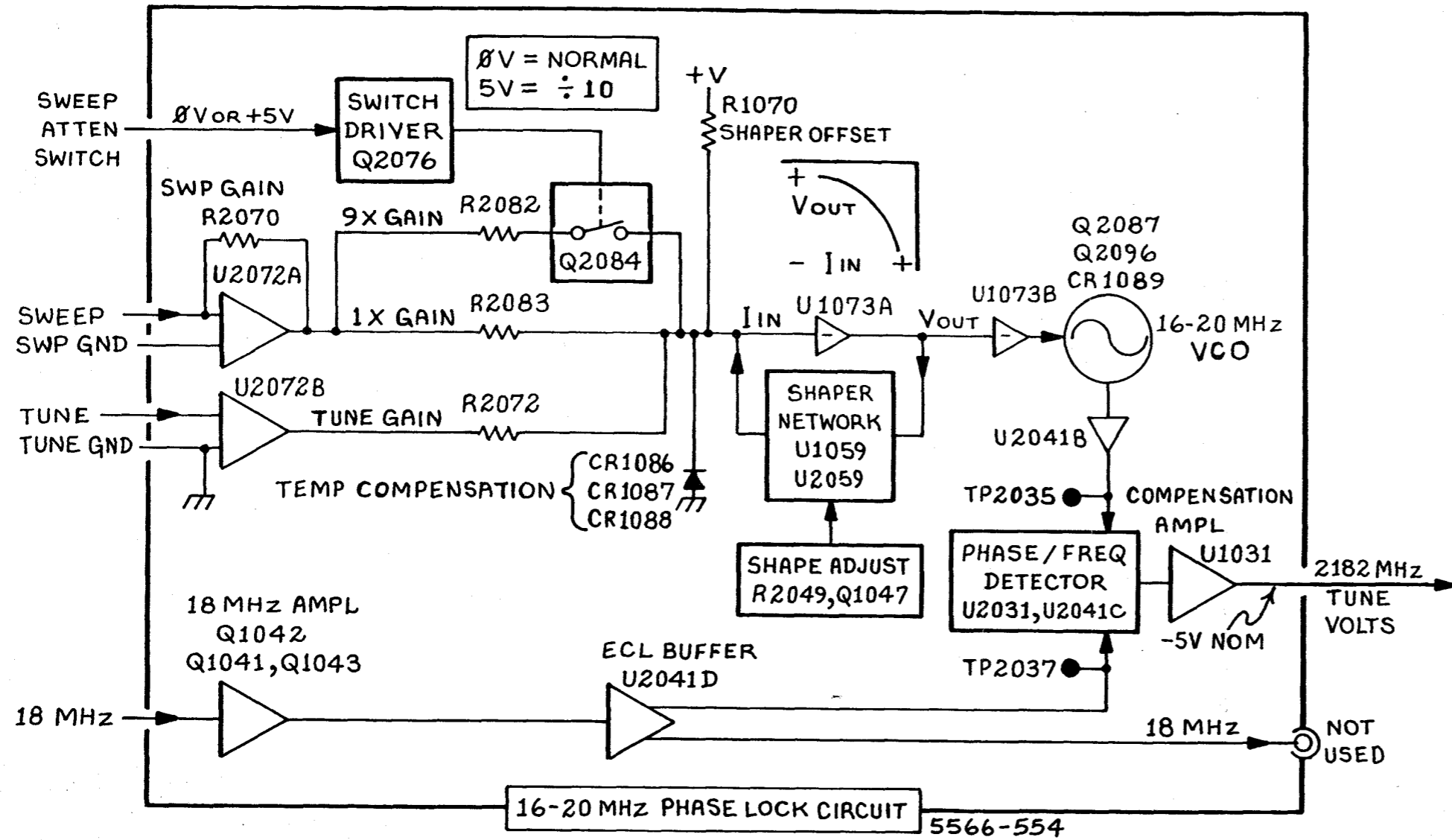

Figure 10-2. A18A1—2072 MHz 2nd Converter circuit board.



5566-552





PHASE LOCKED 2nd LO (16-20 MHz PHASE LOCK)



ASSEMBLY A22A1

CIRCUIT NUMBER	SCHEM LOCATION	BOARD LOCATION	CIRCUIT NUMBER	SCHEM LOCATION	BOARD LOCATION	CIRCUIT NUMBER	SCHEM LOCATION	BOARD LOCATION	CIRCUIT NUMBER	SCHEM LOCATION	BOARD LOCATION
C1012	B3	A1	Q1012	C3	A1	R1073	E4	G1	R2070	B1	F2
C1017	A2	A1	Q1023	B2	B1	R1074	D2	G1	R2071	B1	G2
C1019	B2	A1	Q1041	D4	D1	R1076	D2	G1	R2072	B2	G2
C1026	E3	B1	Q1042	D3	D1	R1079	D1	G1	R2073	F4	G1
C1027	E3	B1	Q1043	D3	D1	R1080	D1	H1	R2074	B1	G2
C1028	E2	B1	Q1047	B2	D1	R1081	D4	H1	R2075	B1	G2
C1029	E3	B1	Q2024	C3	B2	R1082	D2	H1	R2077	B1	G2
C1031	E3	C1	Q2076	B1	G2	R1083	D2	H1	R2080	E4	H2
C1033	E3	C1	Q2084	B1	H2	R1086	D1	H1	R2082	B1	H2
C1034	F3	C1	Q2087	E1	H2	R1087	F1	J1	R2083	B1	H2
C1038	C3	C1	Q2096	E1	J2	R2010	B3	A2	R2084	A1	H2
C1044	D4	D1				R2011	B3	A2	R2085	B1	H2
C1046	C4	D1	R1010	F2	A1	R2012	B4	A2	R2086	B1	H2
C1047	C4	D1	R1011	C3	A1	R2013	B3	B2	R2087	E1	H2
C1073	E4	G1	R1013	B3	A1	R2014	C3	A2	R2088	E1	H2
C1079	D4	G1	R1014	C3	A1	R2015	B3	A2	R2089	E1	H2
C1086	D2	H1	R1015	B3	A1	R2016	B3	B2	R2090	E1	H2
C1087	D1	H2	R1016	B3	A1	R2017	B3	B2	R2092	D1	J2
C1088	D1	H1	R1018	B2	A1	R2018	B3	B2	R2093	E1	J2
C2011	B3	A2	R1019	B3	A1	R2019	B3	B2	R2097	D1	J2
C2012	C3	A2	R1023	B2	B1	R2020	B4	B2			
C2015	B4	A2	R1024	E2	B1	R2025	C3	B2	T1091	D1	J1
C2016	B3	B2	R1024	F2	B1	R2026	E2	B2	T2092	D1	J1
C2019	B3	A2	R1025	E3	B1	R2027	E2	B2			
C2026	E2	B2	R1026	E3	B1	R2028	E2	B2	TP1019	B2	A1
C2030	E3	C2	R1027	E2	B1	R2030	E3	C2	TP1083	D1	H1
C2040	D3	D2	R1028	E2	B1	R2031	E3	C2	TP2035	E2	C1
C2041	C2	D2	R1029	E3	C1	R2032	D3	C2	TP2037	D3	C1
C2043	D3	D2	R1031	E3	C1	R2033	D3	C2			
C2046	D3	D2	R1033	F2	C1	R2034	D3	C2	U1017	B2	A1
C2077	F4	G1	R1034	F3	C1	R2035	D2	C2	U1031	E2	C1
C2081	E4	H2	R1035	F3	C1	R2037	D3	C2	U1031	E3	C1
C2085	E1	H2	R1037	C3	C1	R2039	C2	C2	U1059	C1	E1
C2090	D1	H2	R1038	C3	C1	R2041	D3	D2	U1073A	C1	G1
C2091	E1	J2	R1039	C3	C1	R2042	D2	D2	U1073B	D1	G1
C2092	E1	H2	R1040	C3	D1	R2044	D3	D2	U1073	D4	G1
			R1042	D3	D1	R2045	D2	D2	U2016A	B3	A2
CR1019	B3	A1	R1043	D4	D1	R2046	B2	D2	U2016B	B3	A2
CR1086	D2	H1	R1046	C4	D1	R2049	B2	D2	U2031A	E3	C2
CR1087	D2	H1	R1048	D4	D1	R2051	C2	E2	U2031B	E2	C2
CR1088	D2	H1	R1051	C2	E1	R2052	C2	E2	U2041A	D2	D2
CR1089	D1	H1	R1052	C2	E1	R2053	C2	E2	U2041B	D2	D2
CR2012	C3	A1	R1053	C2	E1	R2054	C2	E2	U2041C	D2	D2
CR2014	B3	A2	R1054	C2	E1	R2055	C2	E2	U2041D	D3	D2
CR2015	B3	B2	R1055	C2	E1	R2056	C2	E2	U2059	B2	E2
CR2019	B3	B2	R1056	C2	E1	R2060	C1	F2	U2072A	B1	G2
CR2048	B2	D2	R1060	C1	F1	R2061	C1	F2	U2072B	B2	G2
CR2084	B1	H2	R1061	C1	F1	R2062	C1	F2	U2072	E4	G2
			R1062	C1	F1	R2063	C1	F2			
L1012	F2	A1	R1063	C1	F1	R2064	C1	F2	VR2021	B4	B2
L1022	F2	B1	R1064	C1	F1	R2065	C1	F2			
L1097	F1	J1	R1065	C1	F1	R2066	A1	F2	W2069	B2	F2
L2027	E2	B2	R1070	C1	G1	R2067	A1	F2	W2081	B2	H2
L2038	C2	C2	R1072	C1	G1	R2068	A2	F2			

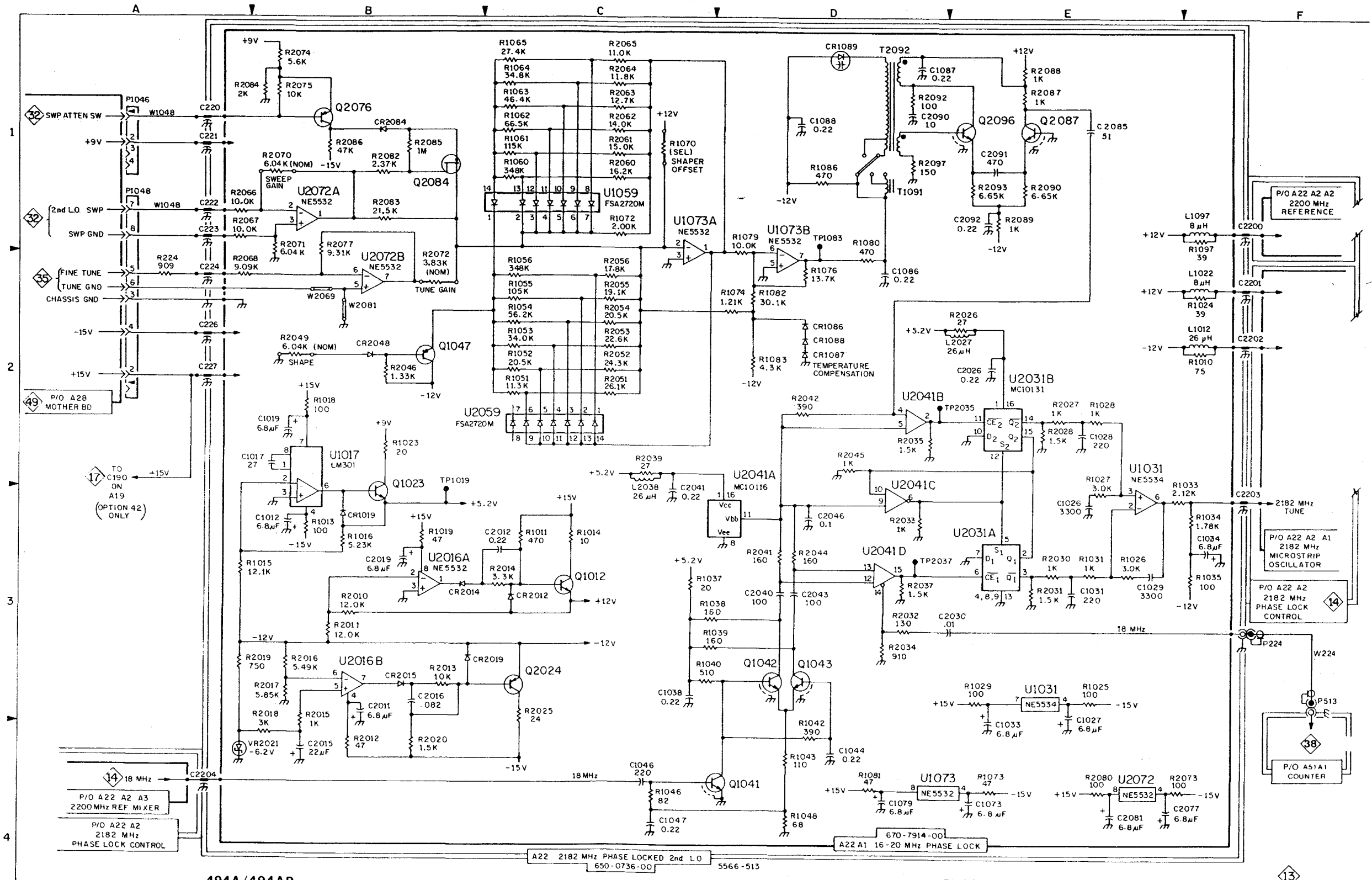

494A/494AP

A22 2182 MHz PHASE LOCKED 2nd L.O 650-0736-00 5566-513

PHASE LOCKED 2nd L.O (16-20MHz PHASE LOCK)

13

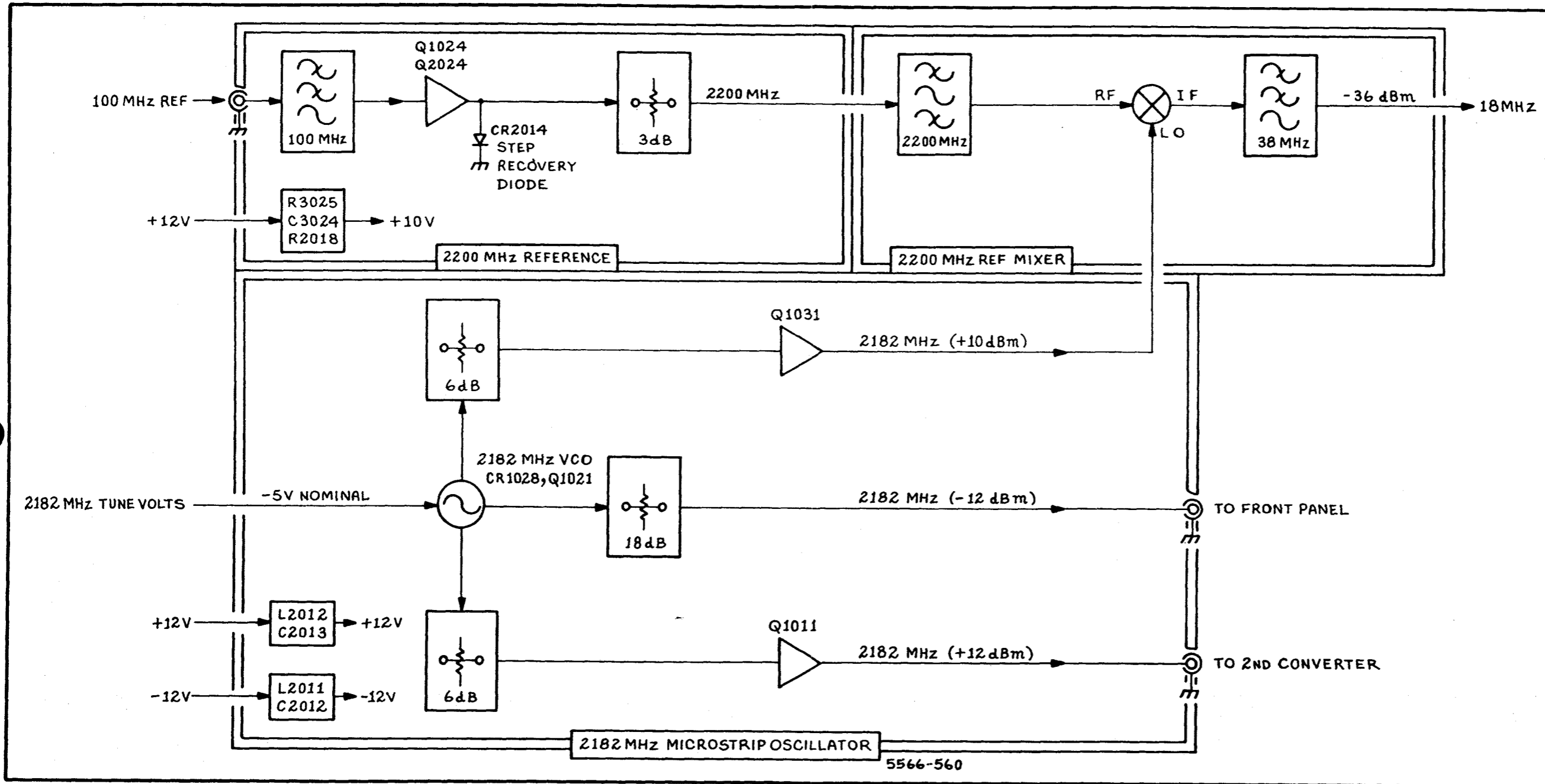

PHASE LOCKED 2nd LO (LO & 2200 MHz REF/CONV)



Assembly A22A2A1

CIRCUIT NUMBER	SCHEM LOCATION	BOARD LOCATION	CIRCUIT NUMBER	SCHEM LOCATION	BOARD LOCATION	CIRCUIT NUMBER	SCHEM LOCATION	BOARD LOCATION
C1011	D1	A1	L1011	D1	A1	R1027	C2	B1
C1013	D2	A1	L1014	C1	A1	R1028	C2	B1
C1014	C1	A1	L2011	A3	A2	R1029	C2	B1
C1021	B2	B1	L2013	A3	A2	R1032	C3	C1
C1021	B3	B1	L2023	B1	B2	R1032	C3	C1
C1022	C1	A1	L2025	B1	B2	R1033	D2	C1
C1023	B3	B1	L2031	A1	C2	R2013	C2	A2
C1031	C2	C1	L2032	C3	C1	R2014	B2	A2
C1033	D2	C1	L2033	D3	C2	R2015	B3	A2
C2011	D2	A2	Q1011	C1	A1	R2016	B3	A2
C2012	A3	A2	Q1021	B3	B2	R2017	A1	A2
C2013	A3	A2	Q1031	C3	C1	R2021	A2	B2
C2023	B2	B2	Q2021	B2	B2	R2022	A2	B2
C2024	A1	B2	R1011	D1	A1	R2023	A1	B2
C2025	B1	B2	R1012	C1	A2	R2024	B2	B2
C2031	A1	B2	R1013	C1	A2	R2025	A1	B2
C2032	D3	C1	R1015	B3	A1	R2030	C3	B2
C2033	D3	C2	R1021	C1	B1	R2031	C3	C2
CR1028	B1	B2	R1022	C1	B1	R2032	C3	C2
CR2013	C2	A2	R1023	C1	B1	R2033	C3	C2
CR2021	A2	B2	R1026	C2	B1	TP1015	B2	A1
CR2031	C3	C2						

Assembly A22A2A2

CIRCUIT NUMBER	SCHEM LOCATION	BOARD LOCATION	CIRCUIT NUMBER	SCHEM LOCATION	BOARD LOCATION	CIRCUIT NUMBER	SCHEM LOCATION	BOARD LOCATION
C1025	B5	B1	E2014	C4	A2	R2023	C5	B2
C1029	B5	B1	E2015	C4	A2	R2032	C5	B2
C1036	B5	C1	L1025	B5	B1	R2033	C5	B2
C1038	B5	C1	L1034	B5	B1	R3014	D4	A3
C2015	C4	A2	Q1024	B5	B2	R3015	C4	A3
C2021	C4	B2	Q2024	C5	B3	R3016	C4	A3
C2023	C5	B2	R2018	A4	A3	R3021	C4	B3
C2026	C5	B2	R2019	C5	A2	R3025	A4	B3
C3015	D4	A3	R2021	C5	B2	T2015	C4	A2
C3024	A4	B3						
CR2014	C4	A2						

Assembly A22A2A3

CIRCUIT NUMBER	SCHEM LOCATION	BOARD LOCATION	CIRCUIT NUMBER	SCHEM LOCATION	BOARD LOCATION	CIRCUIT NUMBER	SCHEM LOCATION	BOARD LOCATION
C1013	E5	A1	CR1011	E3	A1	L1014	E4	A1
C1014	E5	A1	CR1012	E3	A1	L1015	E4	A1
C1015	E4	A1						
C1016	E4	A1	L1013	E5	A1			

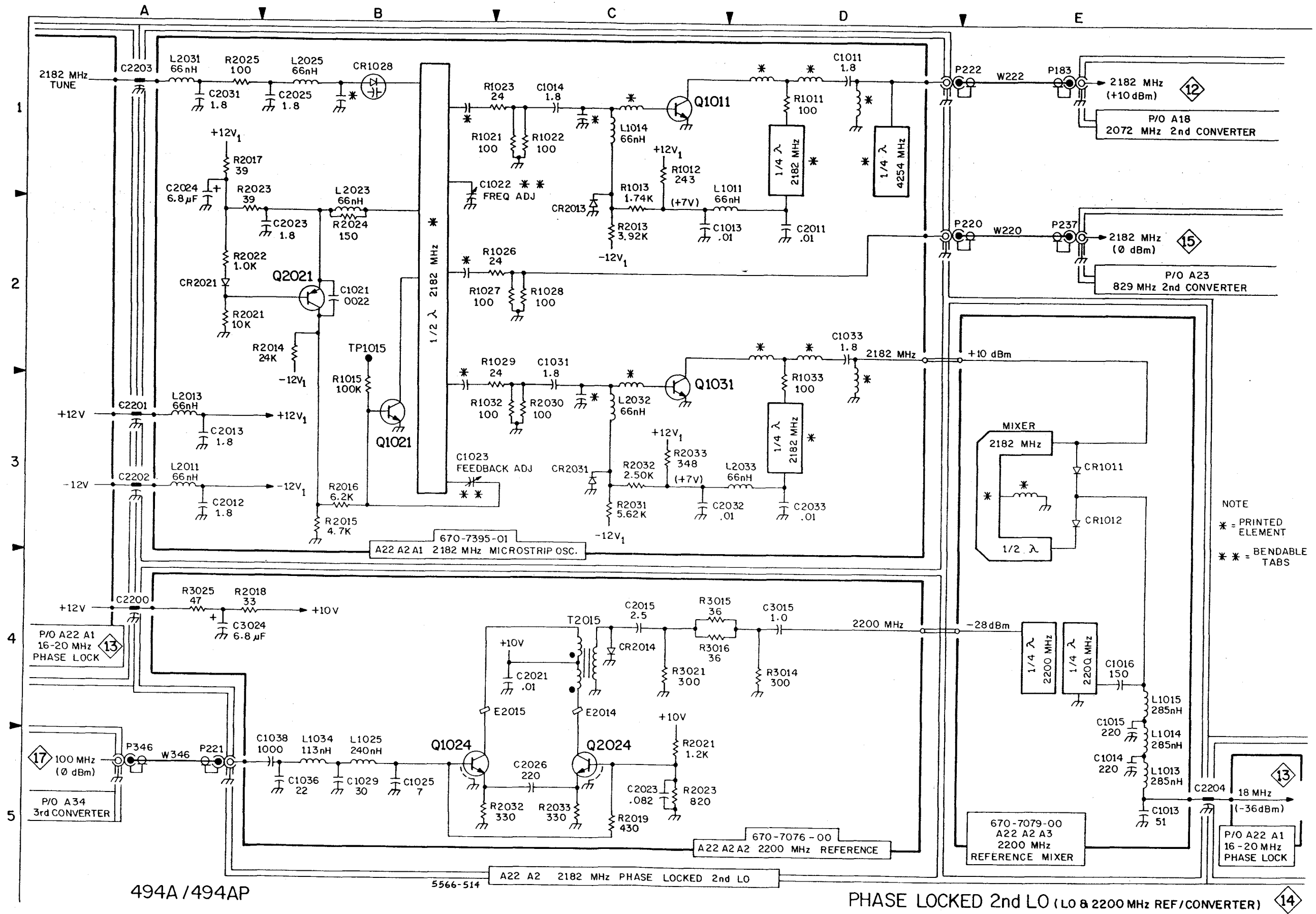

494A / 494AP

5566-514 A22 A2 2182 MHz PHASE LOCKED 2nd LO

PHASE LOCKED 2nd LO (LO & 2200 MHz REF/CONVERTER) 14

NOTE
 * = PRINTED ELEMENT
 ** = BENDABLE TABS

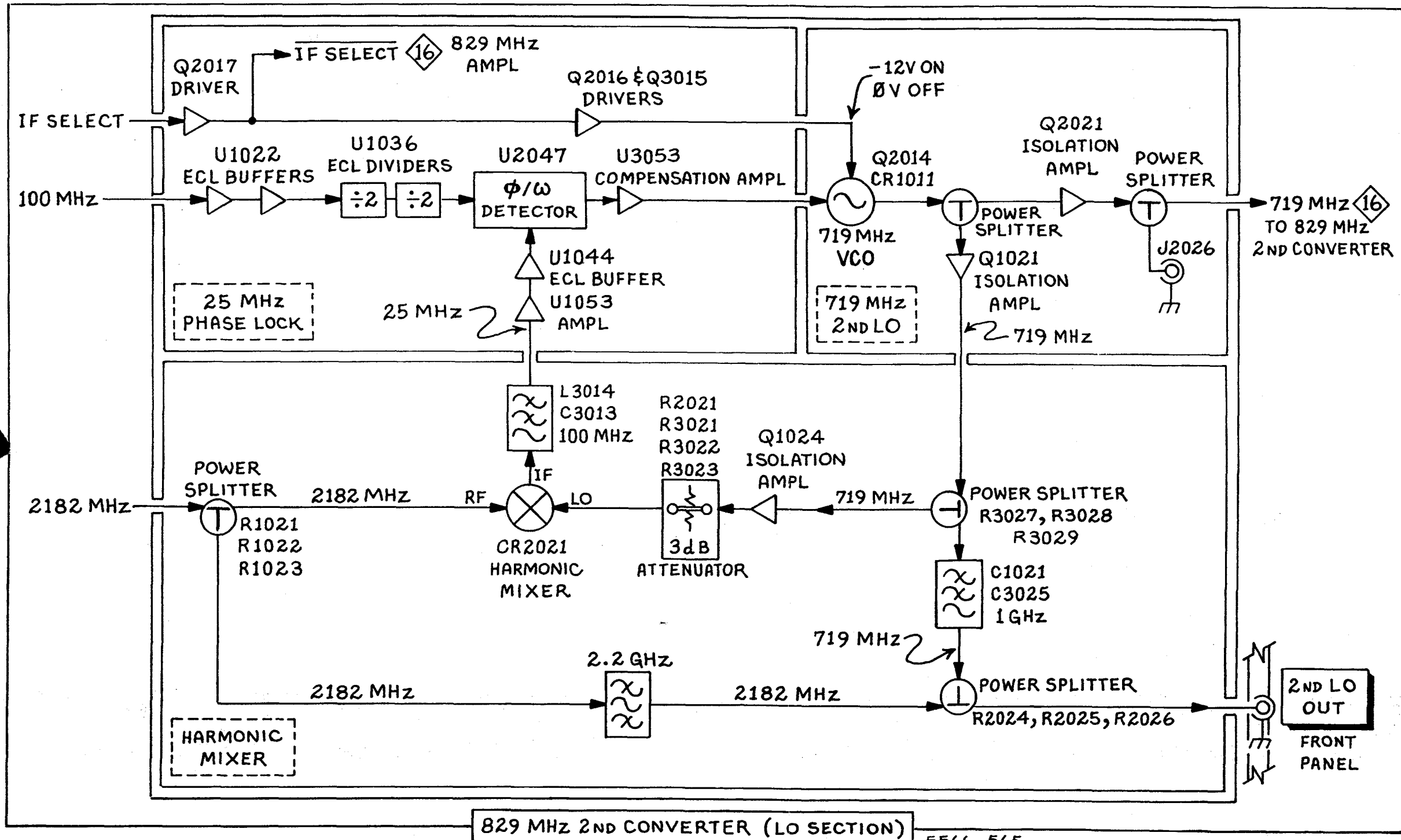

829 MHz 2ND CONVERTER (LO SECTION) 5566-565

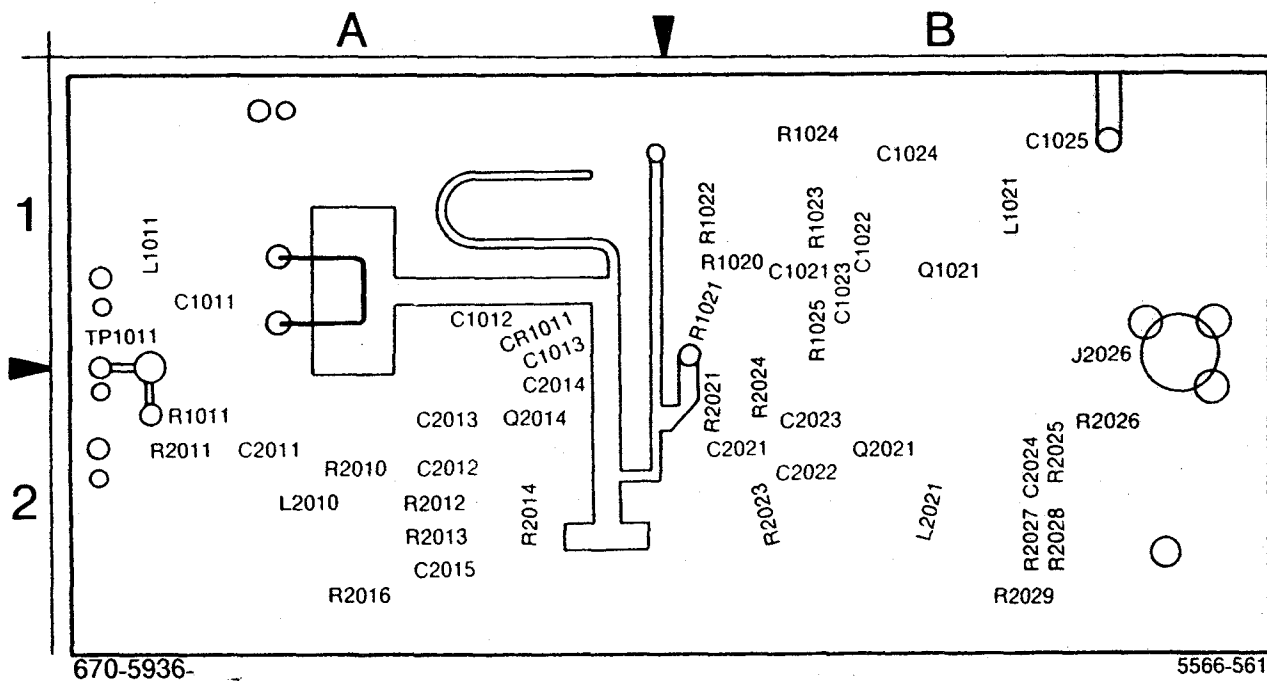

Figure 10-7. A23A1—719 MHz 2nd LO circuit board.

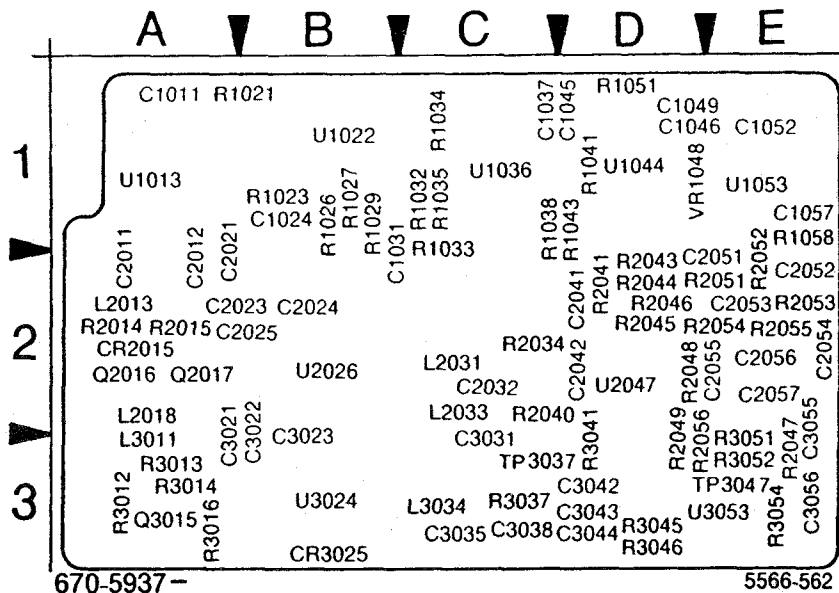

Figure 10-8. A23A2—25 MHz Phase Lock circuit board.

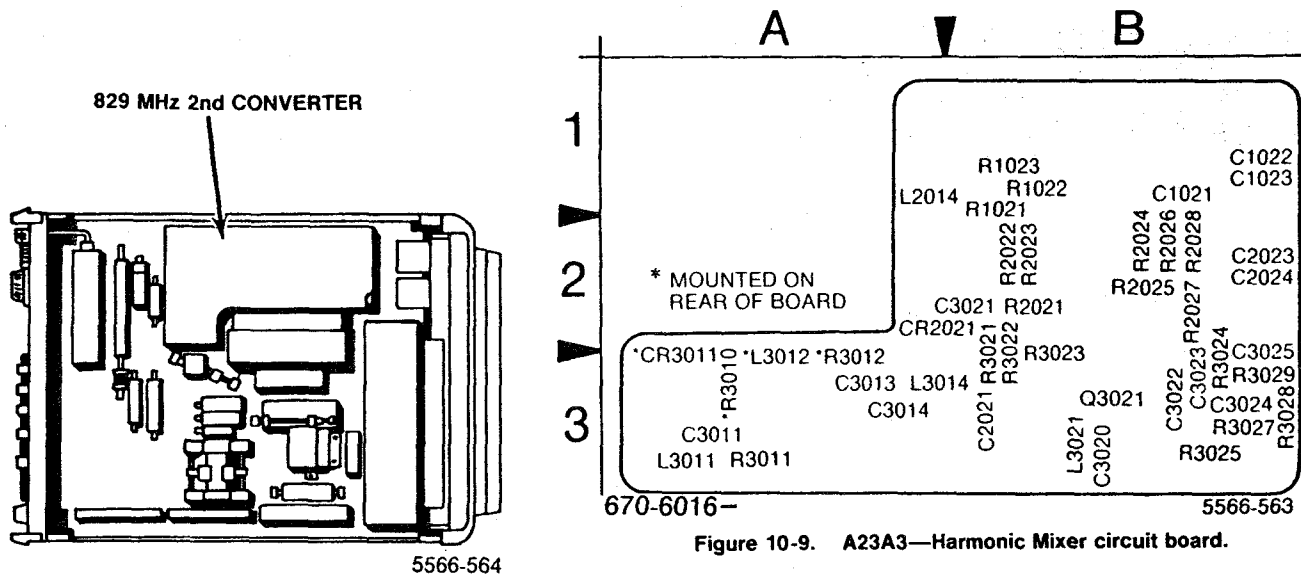
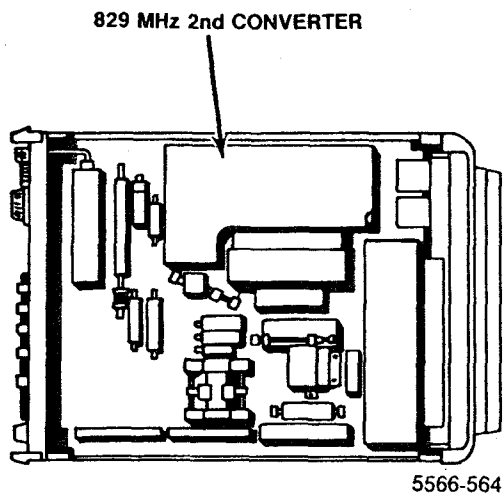

Figure 10-9. A23A3—Harmonic Mixer circuit board.



829 MHz 2nd CONVERTER (LO SECTION)

ASSEMBLY A23A1

CIRCUIT NUMBER	SCHEM LOCATION	BOARD LOCATION	CIRCUIT NUMBER	SCHEM LOCATION	BOARD LOCATION	CIRCUIT NUMBER	SCHEM LOCATION	BOARD LOCATION	CIRCUIT NUMBER	SCHEM LOCATION	BOARD LOCATION
C1011	D3	A1	C2022	E4	B2	Q2014	F3	A2	R2014	F3	A2
C1012	E3	A1	C2023	E4	B2	Q2021	E4	B2	R2016	E3	A2
C1013	E3	A1	C2024	F4	B2				R2021	E4	B2
C1021	D4	B1				R1011	E3	A2	R2023	E4	B2
C1022	D4	B1	CR1011	E3	A1	R1020	D4	B1	R2024	E4	B2
C1023	D4	B1				R1021	E4	B1	R2025	F4	B2
C1024	D4	B1	J2026	F4	B1	R1022	E4	B1	R2026	F4	B2
C1025	D3	B1				R1023	D4	B1	R2027	F4	B2
C2011	F3	A2	L1011	D3	A1	R1024	D3	B1	R2028	F4	B2
C2012	F3	A2	L1021	D4	B1	R1025	D4	B1	R2029	F4	B2
C2013	F3	A2	L2010	E3	A2	R2010	E3	A2			
C2014	F3	A2	L2021	E4	B2	R2011	F2	A2	TP1011	E2	A1
C2015	E4	A2				R2012	F3	A2			
C2021	E4	B2	Q1021	D4	B1	R2013	F3	A2			

ASSEMBLY A23A2

CIRCUIT NUMBER	SCHEM LOCATION	BOARD LOCATION	CIRCUIT NUMBER	SCHEM LOCATION	BOARD LOCATION	CIRCUIT NUMBER	SCHEM LOCATION	BOARD LOCATION	CIRCUIT NUMBER	SCHEM LOCATION	BOARD LOCATION
C1011	A1	A1	C3031	F1	C2	R1034	B1	C1	R3041	E1	D2
C1024	B1	B1	C3035	F1	C3	R1035	C1	C1	R3045	E1	D3
C1031	A1	B1	C3038	E2	C3	R1038	C1	C1	R3046	E1	D3
C1037	B1	C1	C3042	E1	D3	R1041	D1	D1	R3051	E2	E2
C1045	D1	D1	C3043	E2	D3	R1043	D2	D1	R3052	E2	E3
C1046	C2	D1	C3044	E1	D3	R1051	C1	D1	R3054	F2	E3
C1049	C1	D1	C3055	F2	E3	R1058	C2	E1			
C1052	C1	E1	C3056	F2	E3	R2014	E1	A2	TP3037	D1	D3
C1057	B2	E1				R2015	E1	A2	TP3047	E2	E2
C2011	A1	A2	CR2015	F1	A2	R2034	E1	C2			
C2012	B1	A2				R2040	D1	C2	U1013	B1	A1
C2021	B1	A2	L2013	A1	A2	R2041	C1	D2	U1022A	B1	B1
C2021	E4	A2	L2018	A2	A2	R2043	D2	D2	U1022B	B1	B1
C2023	B2	B2	L2031	F1	C2	R2044	D1	D2	U1022	A1	B1
C2023	E4	B2	L2033	F1	C2	R2045	C2	D2	U1036A	C1	C1
C2024	B2	B2	L3011	A2	A3	R2046	D2	D2	U1036B	C1	C1
C2025	A2	B2	L3034	F1	C3	R2047	D2	E3	U1036	B1	C1
C2032	F1	C2				R2048	E2	D2	U1044	D1	D1
C2041	D2	D2	Q2016	F1	A2	R2049	E2	D2	U1053	C1	E1
C2042	D1	D2	Q2017	E1	A2	R2051	C2	E2	U2026	B2	B2
C2051	C2	E2	Q3015	F2	A3	R2052	C2	E2	U2047A	D1	D2
C2052	C2	E2				R2053	F2	E2	U2047B	D2	D2
C2053	F2	E2	R1021	A1	A1	R2054	E2	E2	U2047	E1	D2
C2054	D2	E2	R1021	E4	A1	R2055	E1	E2	U3024	B2	B3
C2055	E2	E2	R1023	B1	B1	R2056	E2	E2	U3053	E2	E3
C2056	F2	E2	R1026	B1	B1	R3012	F1	A3			
C2057	E2	E2	R1027	B1	B1	R3013	F1	A3	VR1048	C2	D1
C3021	A2	A3	R1029	B1	B1	R3014	F1	A3			
C3022	B2	B2	R1032	A1	C1	R3016	F1	A3			
C3023	B2	B2	R1033	B1	C1	R3037	E2	C3			

ASSEMBLY A23A3

CIRCUIT NUMBER	SCHEM LOCATION	BOARD LOCATION	CIRCUIT NUMBER	SCHEM LOCATION	BOARD LOCATION	CIRCUIT NUMBER	SCHEM LOCATION	BOARD LOCATION	CIRCUIT NUMBER	SCHEM LOCATION	BOARD LOCATION
C1021	C4	B1	C3024	C3	B3	R1021	B2	B1	R3012	C3	A3
C1022	C4	B1	C3025	D4	B2	R1022	A3	B1	R3021	B3	B2
C1023	C4	B1				R1023	A2	B1	R3022	B3	B2
C2021	B3	B2	CR2021	B3	B2	R2021	B3	B2	R3023	B3	B2
C2023	C4	B2	CR3011	C3	A3	R2022	B3	B2	R3024	C3	B3
C2024	C4	B2				R2023	B3	B2	R3025	C3	B3
C3011	D3	A3	L2014	B3	A1	R2024	A4	B2	R3027	C3	B3
C3013	B2	A3	L3011	D3	A3	R2025	B4	B2	R3028	D3	B3
C3014	B3	A3	L3012	C3	A3	R2026	A4	B2	R3029	C3	B3
C3020	C3	B3	L3014	B3	A3	R2027	B4	B2			
C3021	B3	B3	L3021	C3	B3	R2028	B4	B2			
C3022	C3	B3				R3010	C3	A3			
C3023	C3	B3	Q3021	C3	B3	R3011	C3	A3			

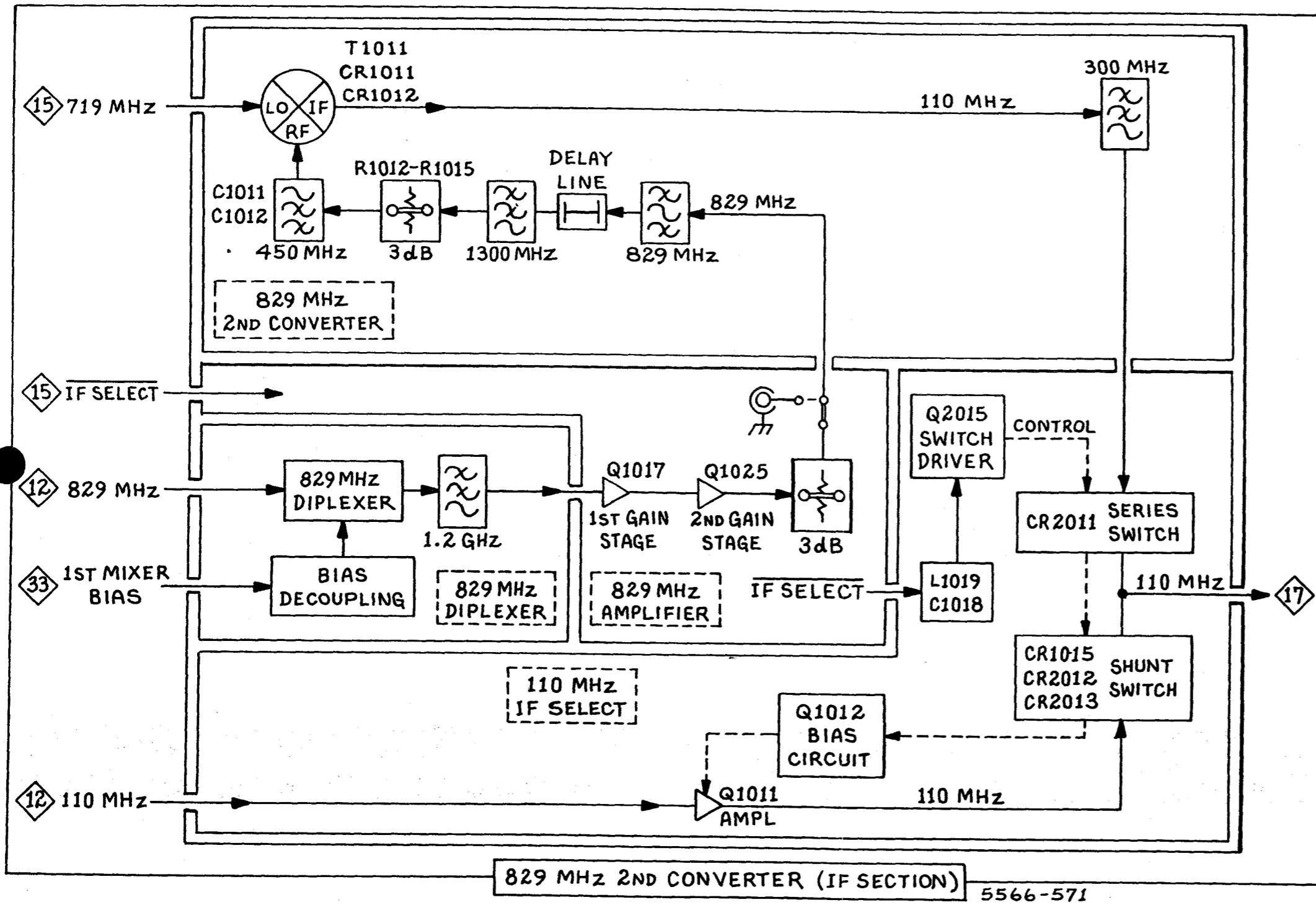

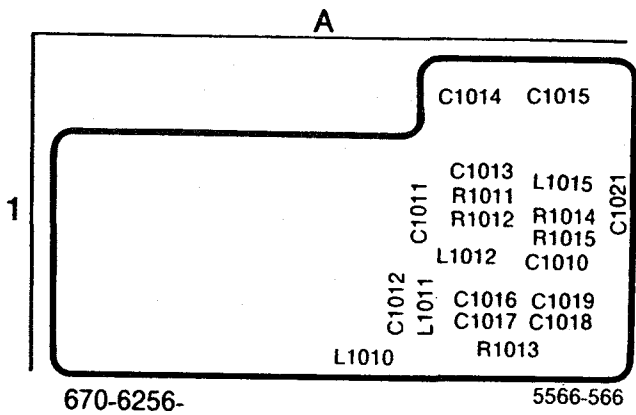

Figure 10-10. A23A4—829 MHz Diplexer circuit board.

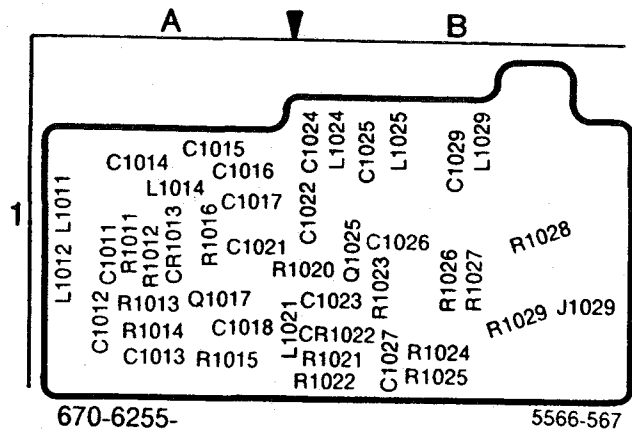

Figure 10-11. A23A5—829 MHz Amplifier circuit board.

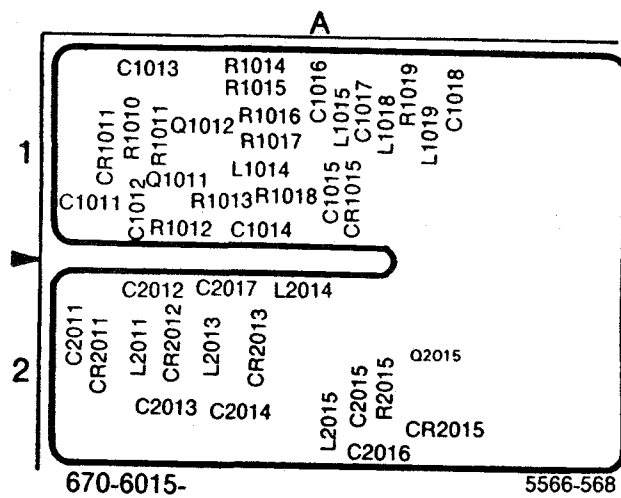
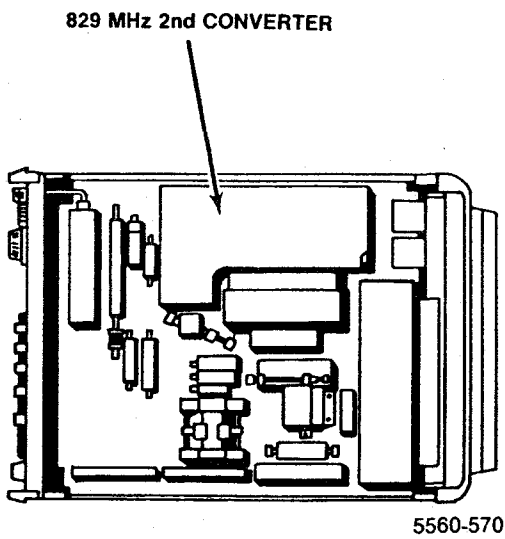

Figure 10-12. A23A6—110 MHz IF Select circuit board.

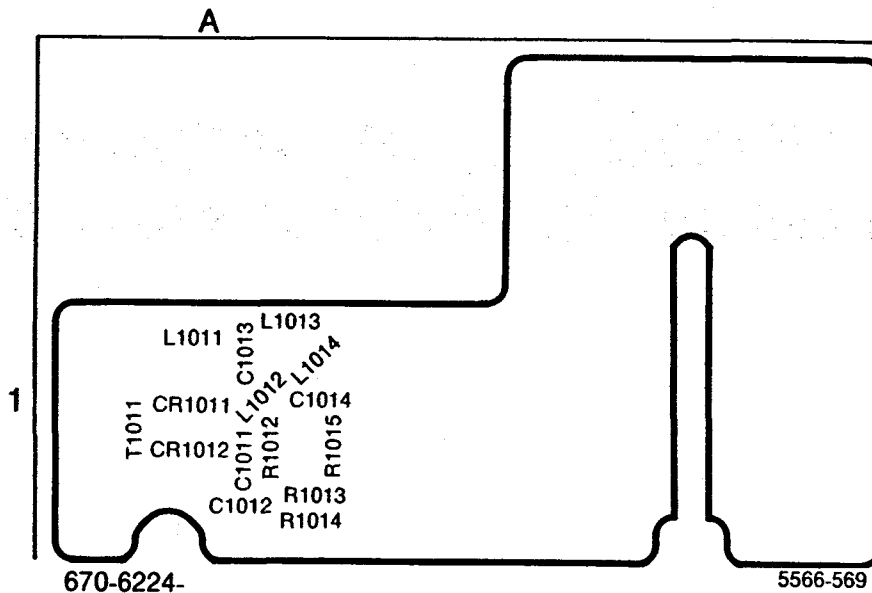

Figure 10-13. A23A7—829 MHz 2nd Converter circuit board.

829 MHz 2nd CONVERTER (IF SECTION)



ASSEMBLY A23A4

CIRCUIT NUMBER	SCHEM LOCATION	BOARD LOCATION	CIRCUIT NUMBER	SCHEM LOCATION	BOARD LOCATION	CIRCUIT NUMBER	SCHEM LOCATION	BOARD LOCATION
C1010	A2	A1	C1018	B3	A1	R1011	B2	A1
C1011	B3	A1	C1019	B3	A1	R1012	B2	A1
C1012	A3	A1	C1021	A3	A1	R1013	A3	A1
C1013	B2	A1				R1014	A2	A1
C1014	A3	A1	L1010	A3	A1	R1015	A2	A1
C1015	B3	A1	L1011	A3	A1			
C1016	B3	A1	L1012	B3	A1			
C1017	B3	A1	L1015	A3	A1			

ASSEMBLY A23A5

CIRCUIT NUMBER	SCHEM LOCATION	BOARD LOCATION	CIRCUIT NUMBER	SCHEM LOCATION	BOARD LOCATION	CIRCUIT NUMBER	SCHEM LOCATION	BOARD LOCATION
C1011	D3	A1	CR1013	C2	A1	R1012	C2	A1
C1012	D3	A1	CR1022	D2	B1	R1013	C2	A1
C1013	C2	A1				R1014	D2	A1
C1014	C2	A1	J1029	D2	B1	R1015	D2	A1
C1015	C3	A1				R1016	C2	A1
C1016	C2	A1	L1011	D3	A1	R1020	D2	B1
C1017	C3	A1	L1012	D3	A1	R1021	D2	B1
C1018	D2	A1	L1014	C2	A1	R1022	D2	B1
C1021	D2	A1	L1021	D2	A1	R1023	D2	B1
C1022	D2	B1	L1024	A1	B1	R1024	D2	B1
C1023	D2	B1	L1025	A2	B1	R1025	D2	B1
C1024	A2	B1	L1029	A2	B1	R1026	D2	B1
C1025	A2	B1				R1027	D2	B1
C1026	D2	B1	Q1017	D3	A1	R1028	D2	B1
C1027	D2	B1	Q1025	D2	B1	R1029	D2	B1
C1029	A2	B1						
			R1011	C2	A1			

ASSEMBLY A23A6

CIRCUIT NUMBER	SCHEM LOCATION	BOARD LOCATION	CIRCUIT NUMBER	SCHEM LOCATION	BOARD LOCATION	CIRCUIT NUMBER	SCHEM LOCATION	BOARD LOCATION
C1011	A4	A1	CR1011	B4	A1	Q1011	B4	A1
C1012	B4	A1	CR1015	B3	A1	Q1012	B4	A1
C1013	A4	A1	CR2011	E4	A2	Q2015	D4	A2
C1014	B4	A1	CR2012	C4	A2			
C1015	B3	A1	CR2013	C4	A2	R1010	B4	A1
C1016	D3	A1	CR2015	D4	A2	R1011	B4	A1
C1017	D3	A1				R1012	B4	A1
C1018	D4	A1	L1014	B4	A1	R1013	B4	A1
C2011	E4	A2	L1015	D3	A1	R1014	A4	A1
C2012	C4	A2	L1018	D3	A1	R1015	A4	A1
C2013	C4	A2	L1019	D3	A1	R1016	A3	A1
C2014	C4	A2	L2011	C4	A2	R1017	B3	A1
C2015	D4	A2	L2013	C4	A2	R1018	B4	A1
C2016	E4	A2	L2014	C4	A2	R1019	D3	A1
C2017	C4	A2	L2015	D4	A2	R2015	D4	A2

ASSEMBLY A23A7

CIRCUIT NUMBER	SCHEM LOCATION	BOARD LOCATION	CIRCUIT NUMBER	SCHEM LOCATION	BOARD LOCATION	CIRCUIT NUMBER	SCHEM LOCATION	BOARD LOCATION
C1011	B1	A1	L1011	D1	A1	R1014	B1	A1
C1012	B1	A1	L1012	D1	A1	R1015	C1	A1
C1013	D1	A1	L1013	D1	A1			
C1014	D1	A1	L1014	D1	A1	T1011	A1	A1
CR1011	B1	A1	R1012	B1	A1			
CR1012	B1	A1	R1013	B1	A1			

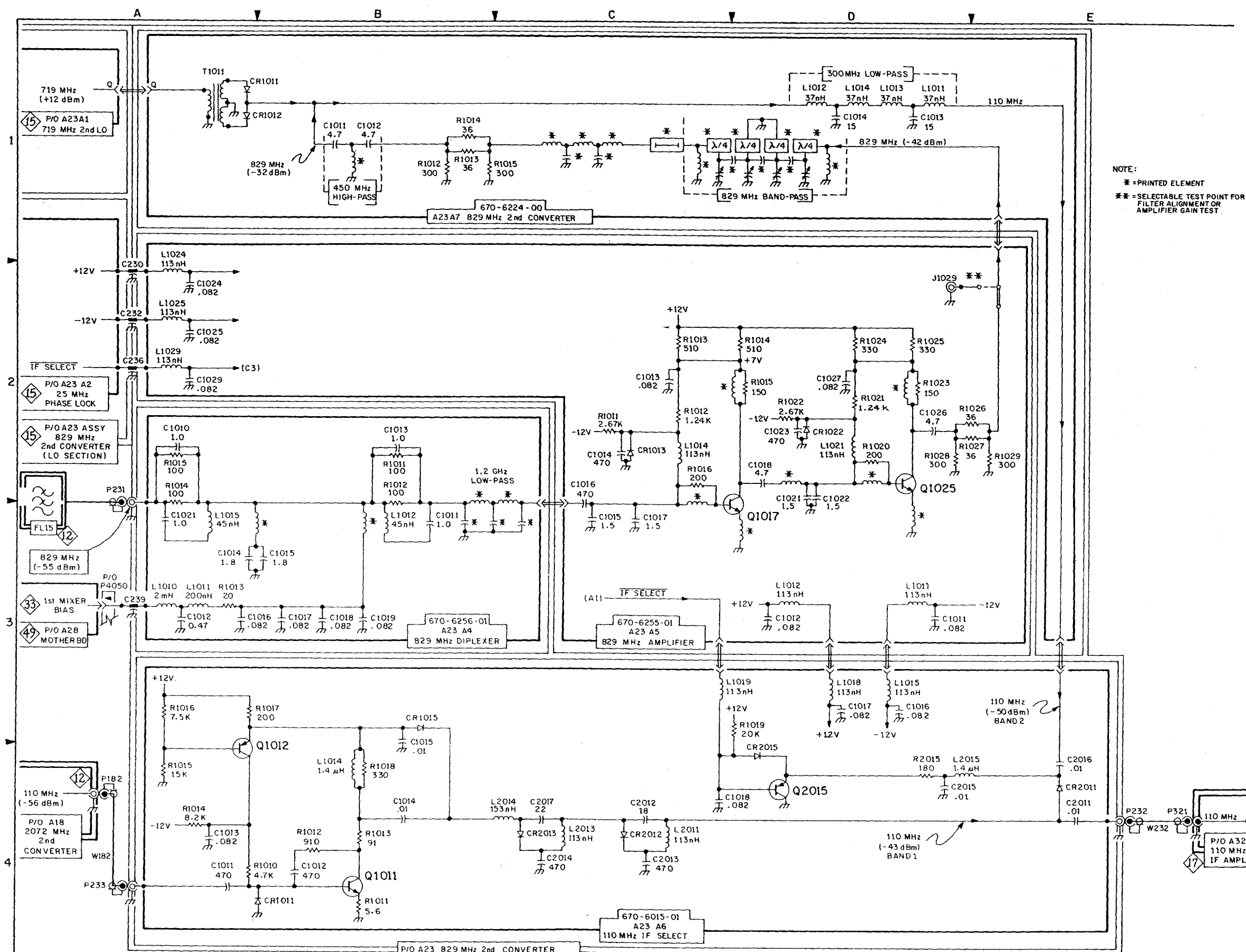

NOTE:
 * = PRINTED ELEMENT
 ** = SELECTABLE TEST POINT FOR FILTER ALIGNMENT OR AMPLIFIER GAIN TEST

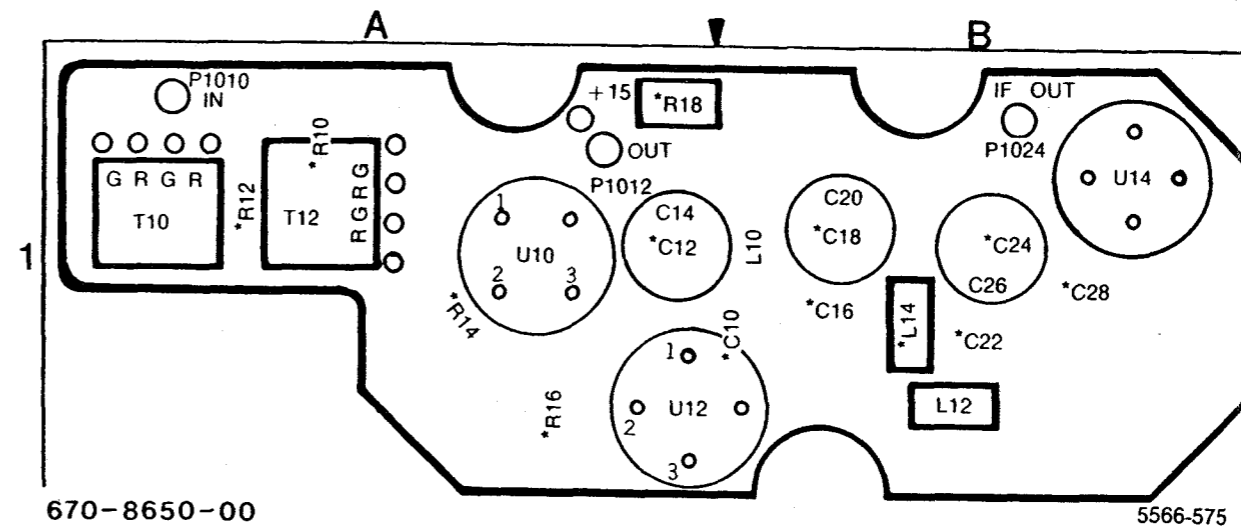
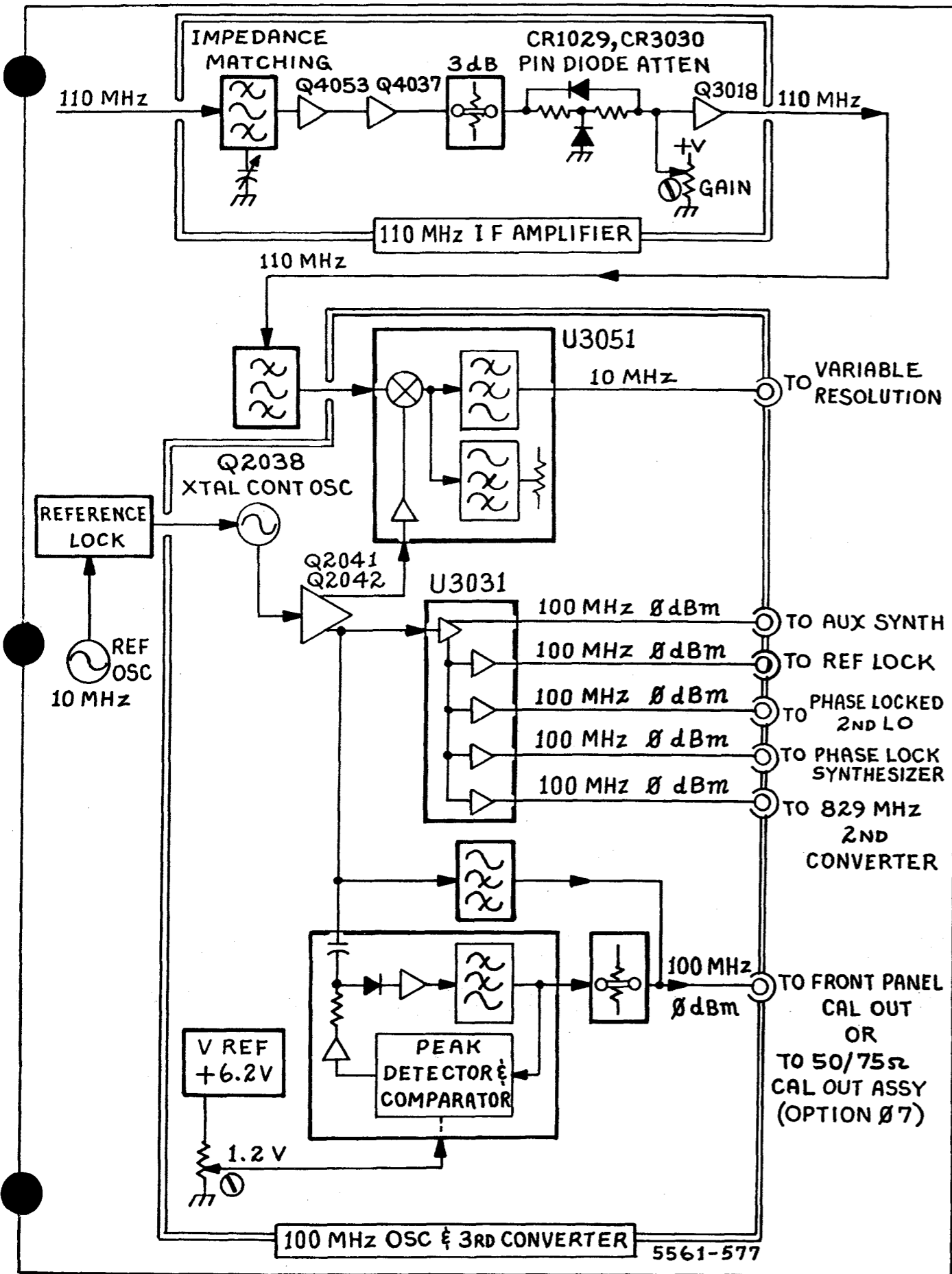
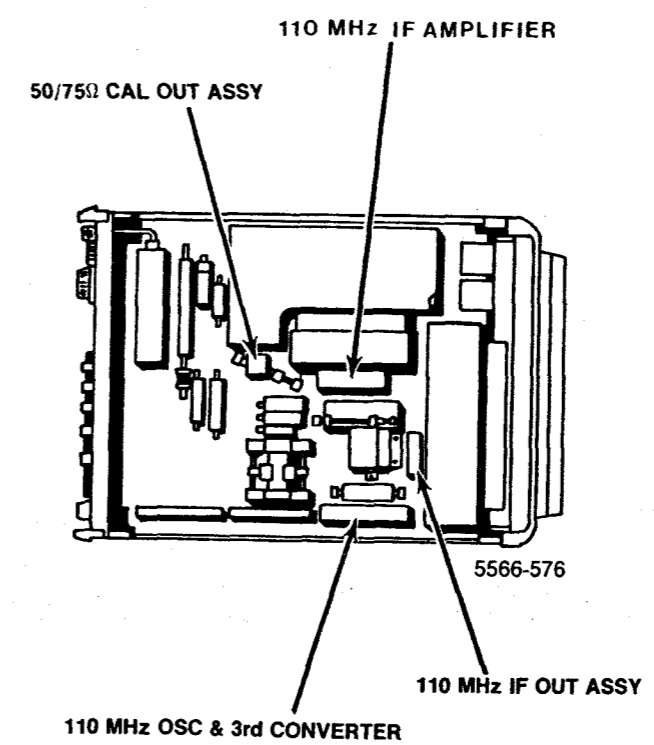

Figure 10-17. A19A1—110 MHz IF Out circuit board. (Option 42 only)

* MOUNTED ON REAR OF BOARD



110 MHz IF & 3rd CONVERTER



ASSEMBLY A32A1

CIRCUIT NUMBER	SCHEM LOCATION	BOARD LOCATION	CIRCUIT NUMBER	SCHEM LOCATION	BOARD LOCATION	CIRCUIT NUMBER	SCHEM LOCATION	BOARD LOCATION	CIRCUIT NUMBER	SCHEM LOCATION	BOARD LOCATION
C1012	C1	A1	C4020	C1	B4	Q4037	B1	C4	R3035	C1	C3
C1022	C1	B2	C4026	C1	B4	Q4053	B1	E4	R3042	B1	D2
C1054	A1	E1	C4035	B1	C4				R4012	C1	B4
C2010	C1	A2	C4036	B1	C4	R1012	C1	A1	R4018	C1	B4
C2012	C1	A2	C4045	A1	D4	R1015	C1	A1	R4029	C1	B4
C2029	C1	B2				R2014	C1	A2	R4030	B1	B4
C2035	B2	C1	CR1029	C1	C1	R2019	C1	B1	R4032	B1	B4
C2036	B2	D1	CR3030	C1	C3	R2028	C1	B3	R4038	B1	D4
C2037	B1	D2				R2029	C1	B2	R4039	A1	D4
C2047	A1	D2	E3036	B1	C4	R2030	C1	B2	R4043	B1	D3
C2051	A1	E2	E4046	B1	D4	R2032	C1	C1	R4047	A1	D4
C3032	B1	C3				R2038	B1	D2	R4058	A1	E4
C3036	B1	D3	L1039	B2	D1	R2039	B1	D2			
C3043	B1	D3	L2044	A1	E1	R2043	B1	D2	T2020	C1	B2
C3044	B1	D3				R3014	C1	A3	T3041	B1	D3
C3045	B1	D3	Q3018	C1	A3	R3029	C1	B3	T3054	B1	E3

ASSEMBLY A34A1

CIRCUIT NUMBER	SCHEM LOCATION	BOARD LOCATION	CIRCUIT NUMBER	SCHEM LOCATION	BOARD LOCATION	CIRCUIT NUMBER	SCHEM LOCATION	BOARD LOCATION	CIRCUIT NUMBER	SCHEM LOCATION	BOARD LOCATION
C1026	C3	B1	J1011	D3	A1	Q2042	B3	D2	R3032	B3	C3
C1038	A2	C1	J1012	D3	A1				R3034	A3	C3
C1044	A2	D1	J1032	D3	C1	R1011	C3	A1	R3035	B3	C3
C1049	B2	D1	J1050	D2	E1	R1021	C4	B1	R3041	B3	D3
C2011	C3	A2	J1054	D2	E1	R1022	C4	B1	R3042	B3	D3
C2021	C3	A2	J3011	D2	A3	R1024	C4	B1	R3044	B2	D3
C2022	C3	B2	J3019	D3	A3	R1041	B4	D1	R3046	B2	D3
C2023	C3	B2	J3027	A4	B3	R1042	B4	D1			
C2033	A3	C3	J3032	A3	C3	R1043	B4	D1	TP1011	B4	A1
C2039	B3	C2	J3042	A4	D3	R1044	B2	D1	TP2042	B3	D2
C2041	B3	D2	J3052	A4	E3	R1045	B2	D1	TP3011	B4	A3
C2042	B3	D2	J3054	D2	E3	R1048	B2	D1	TP3042	A3	D3
C2044	B2	D2				R1051	B4	E1			
C2046	C3	D2	L1041	B2	D1	R2011	C4	A2	U2022	C4	A2
C3022	A4	B3	L2022	C3	B2	R2038	A3	C2	U3031	D3	C3
C3036	B3	C3	L2023	C3	B2	R2042	B3	D2	U3051	D2	E3
C3041	B4	D3	L2052	D2	E3	R2044	B2	D2			
C3046	B2	D3	L3041	B3	D3	R2045	C3	D2	VR1051	B4	E1
C3055	A4	E3				R2046	C3	D2			
			Q2038	B3	C2	R2047	B3	D2	Y3038	B3	C3
CR3039	B3	C3	Q2041	B2	D2	R3031	B3	C3			

ASSEMBLY A34A3A1

CIRCUIT NUMBER	SCHEM LOCATION	BOARD LOCATION	CIRCUIT NUMBER	SCHEM LOCATION	BOARD LOCATION	CIRCUIT NUMBER	SCHEM LOCATION	BOARD LOCATION	CIRCUIT NUMBER	SCHEM LOCATION	BOARD LOCATION
C1010	E4	A1	CR1014	E4	A1	K1010	E3	A1	R1014	F4	A1
			CR1016	E4	A1				R1016	E4	A1
CR1010	E4	A1	CR1018	E4	A1	R1010	E3	A1			
CR1012	F4	A1	CR1019	E4	A1	R1012	E4	A1			

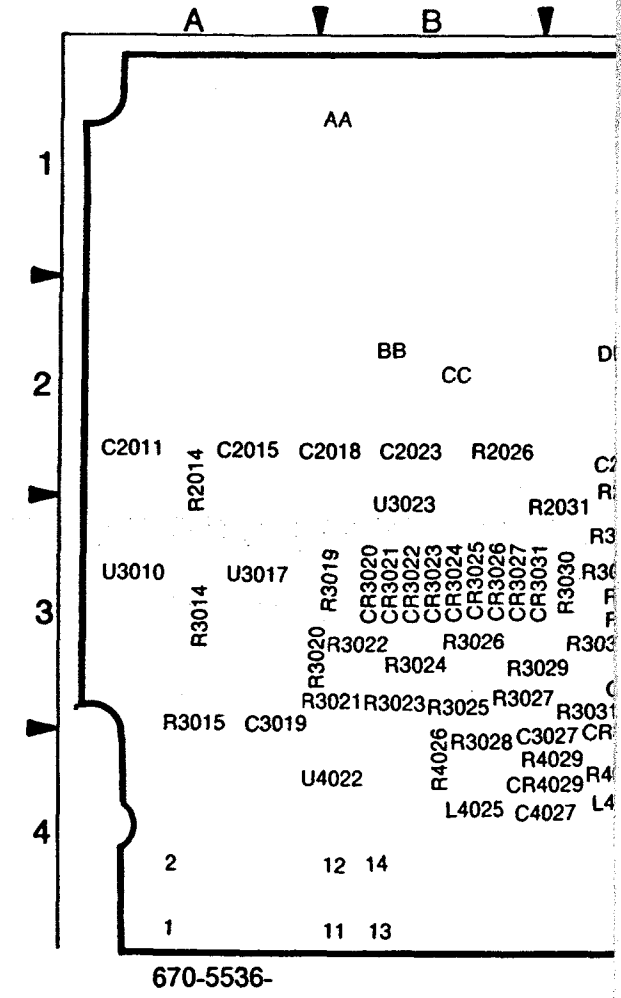
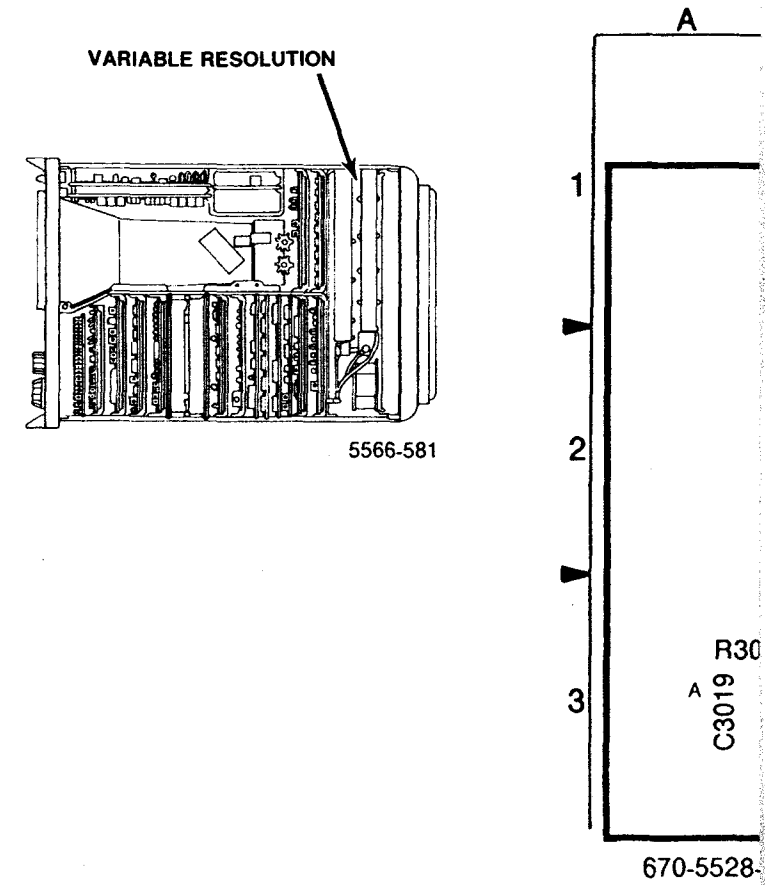
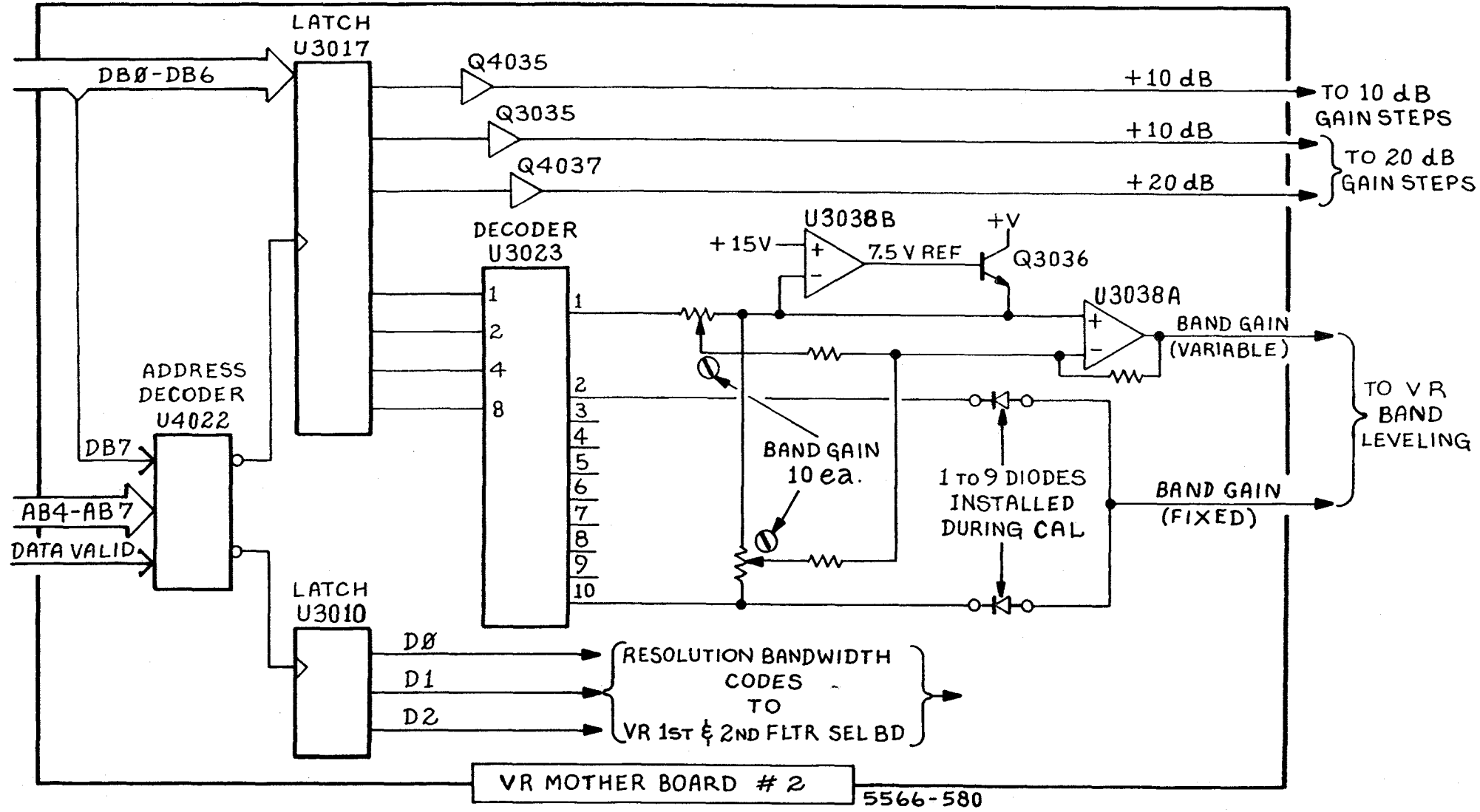

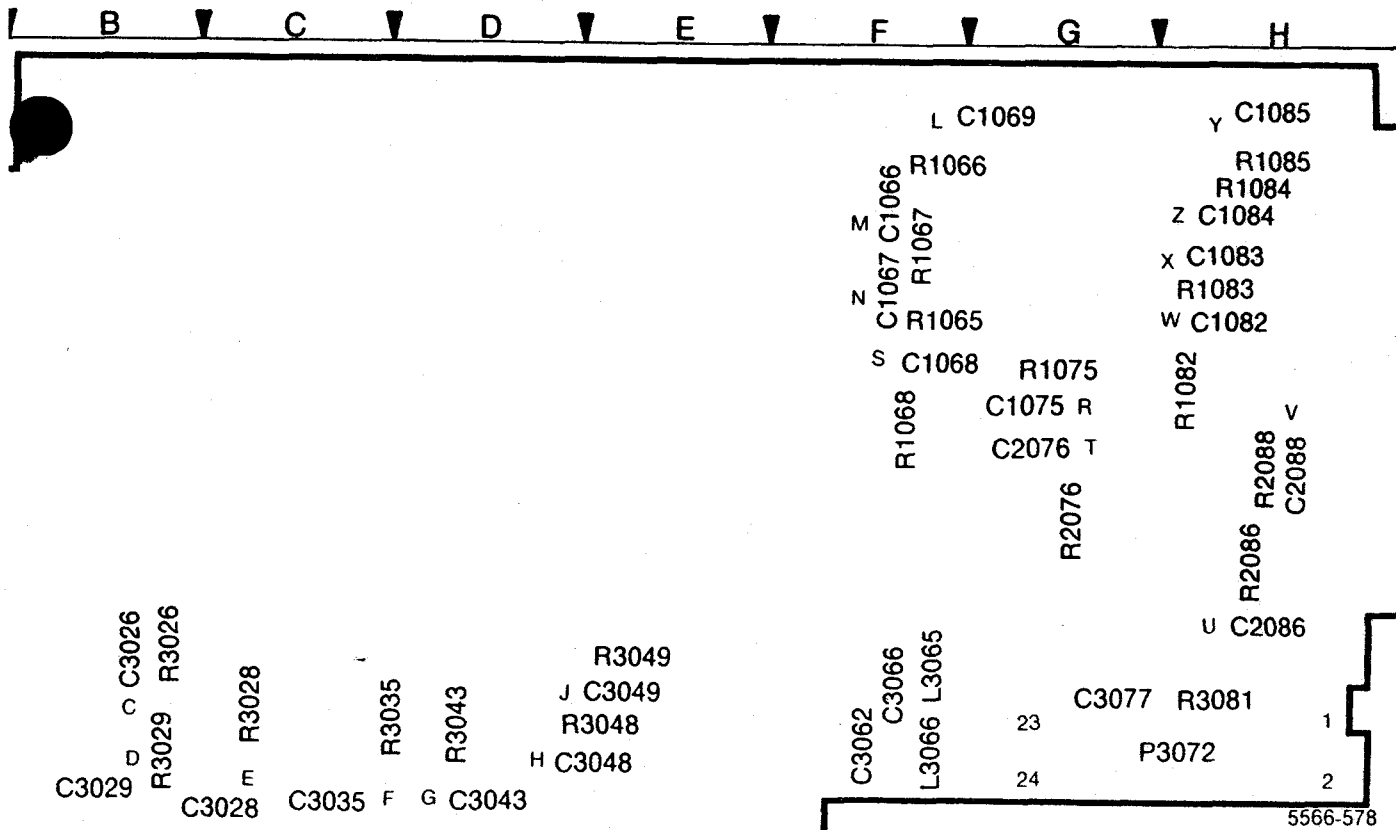

Figure 10-18. A68A1—VR Mother board #1 circuit board.

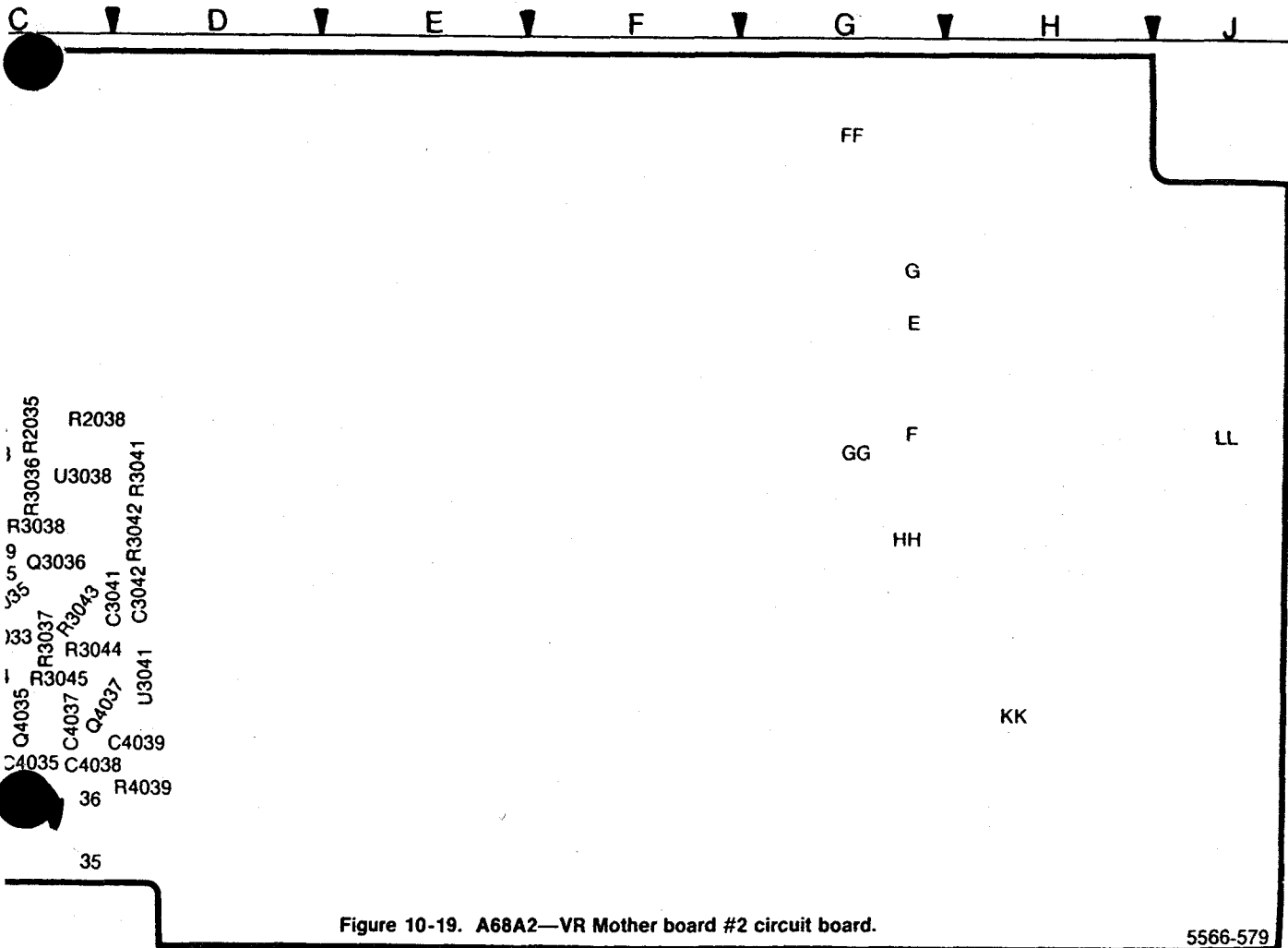

Figure 10-19. A68A2—VR Mother board #2 circuit board.

VARIABLE RESOLUTION MOTHER BOARDS

18

ASSEMBLY A68A1

CIRCUIT NUMBER	SCHEM LOCATION	BOARD LOCATION	CIRCUIT NUMBER	SCHEM LOCATION	BOARD LOCATION	CIRCUIT NUMBER	SCHEM LOCATION	BOARD LOCATION
C1066	D1	F1	C3035	D1	C3	R1075	E1	G2
C1067	C1	F1	C3043	D1	D3	R1082	F2	H2
C1068	D1	F2	C3048	E1	E3	R1083	F2	H1
C1068	E1	F2	C3049	E1	E3	R1084	D1	H1
C1069	E1	G1	C3062	A1	F3	R1085	C1	H1
C1075	E1	G2	C3066	B1	F3	R2076	C1	G2
C1082	F2	H1	C3077	C1	G3	R2086	D1	H2
C1083	F2	H1				R2088	C1	H2
C1084	D2	H1	L3065	A1	F3	R3019	F1	A3
C1085	C1	H1	L3066	A1	F3	R3026	F2	B3
C2076	C1	G2				R3028	C1	C3
C2086	E3	H3	P3072	A1	H3	R3029	E1	B3
C2088	C1	H2	P3072	C2	H3	R3035	D1	C3
C3019	F1	A3				R3043	D1	D3
C3026	E1	B3	R1065	C1	F1	R3048	E1	E3
C3026	E1	B3	R1066	F1	F1	R3049	E1	E3
C3028	D1	C3	R1067	D1	F1	R3081	C1	H3
C3029	E1	B3	R1068	D1	F2			

ASSEMBLY A68A2

CIRCUIT NUMBER	SCHEM LOCATION	BOARD LOCATION	CIRCUIT NUMBER	SCHEM LOCATION	BOARD LOCATION	CIRCUIT NUMBER	SCHEM LOCATION	BOARD LOCATION
C2011	A2	A2	L4025	A3	B4	R3031	E3	C3
C2015	B2	A2	L4031	A2	C4	R3032	E4	C3
C2018	C3	A2				R3033	E3	C3
C2023	E2	B2	Q3035	C2	C3	R3034	E2	C3
C2033	E5	C2	Q3036	D2	C3	R3035	D2	C3
C3019	A2	A3	Q4035	C2	C4	R3036	E2	C3
C3027	A3	B4	Q4037	C3	C4	R3037	C2	C3
C3041	D2	C3				R3038	E2	C3
C3042	B6	D3	R2014	B2	A2	R3039	D2	C3
C4027	A2	B4	R2026	E2	B2	R3041	D2	D3
C4035	C2	C4	R2031	E2	B3	R3042	D2	D3
C4037	C2	C4	R2033	E2	C3	R3043	C2	C3
C4038	C2	C4	R2035	E2	C2	R3044	C3	C3
C4039	B3	C4	R2038	E2	C2	R3045	C2	C4
			R3014	B2	A3	R4026	E4	B4
CR3020	E2	B3	R3015	C2	A3	R4029	C2	B4
CR3021	E3	B3	R3019	E3	A3	R4031	C2	C4
CR3022	E3	B3	R3020	E3	A3	R4039	B3	C4
CR3023	E3	B3	R3021	E3	B3			
CR3024	E3	B3	R3022	E3	B3	U3010	B3	A3
CR3025	E3	B3	R3023	E3	B3	U3017	B2	A3
CR3026	E3	B3	R3024	E3	B3	U3023	C3	B3
CR3027	E3	B3	R3025	E3	B3	U3038A	E2	C3
CR3031	E3	B3	R3026	E3	B3	U3038B	D2	C3
CR3033	B2	C3	R3027	E4	B3	U3041	B6	D4
CR3034	C3	C4	R3028	E4	B4	U4022	B3	B4
CR4029	B2	B4	R3029	E4	B3			
			R3030	E3	B3			

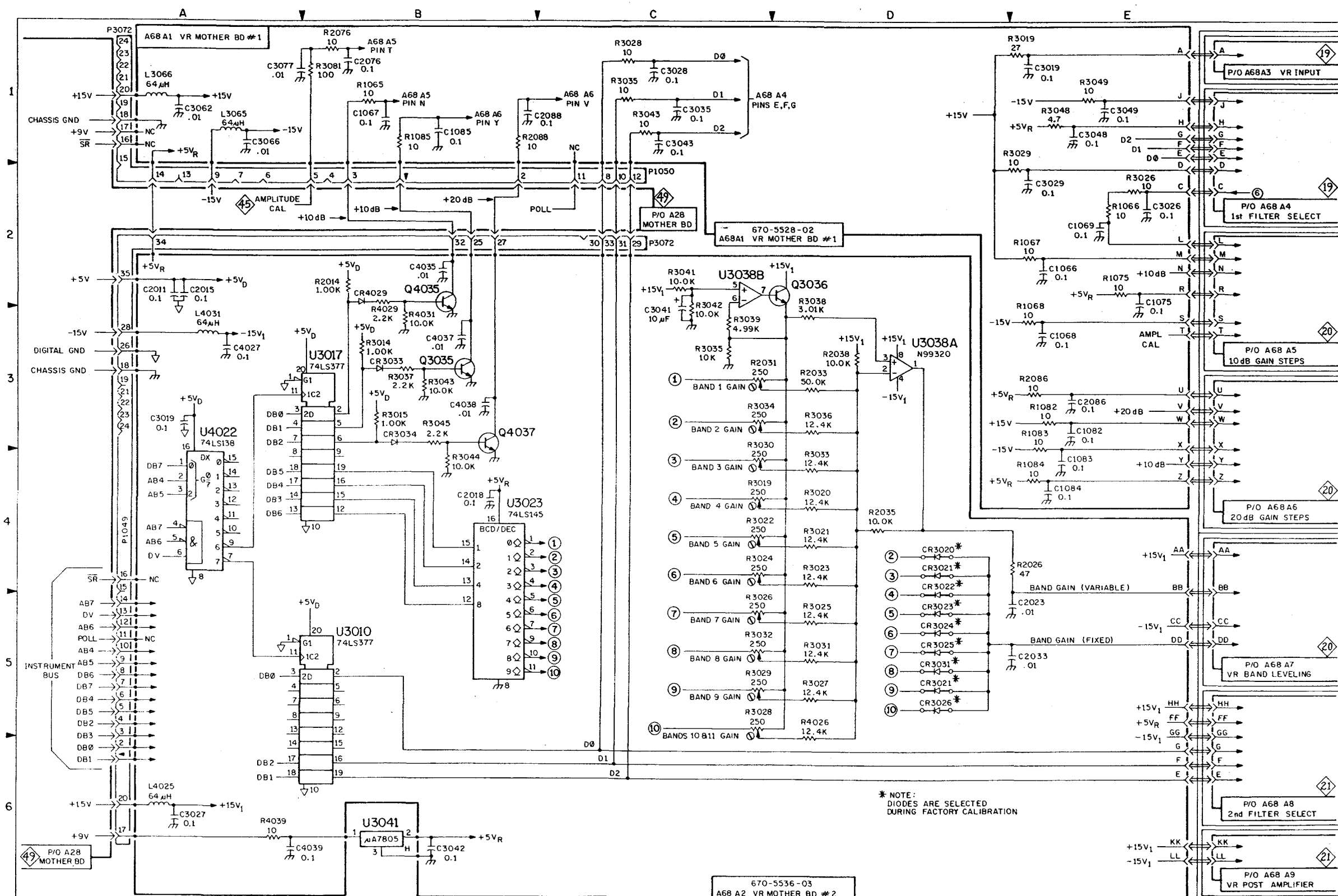

494A/494AP

5561-518

670-5536-03
A68 A2 VR MOTHER BD #2

* NOTE:
DIODES ARE SELECTED
DURING FACTORY CALIBRATION

VARIABLE RESOLUTION MOTHER BOARDS

18

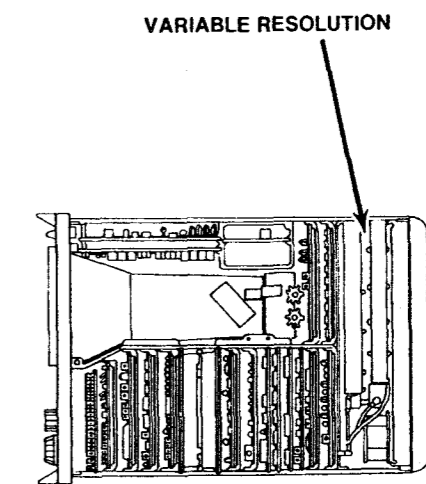
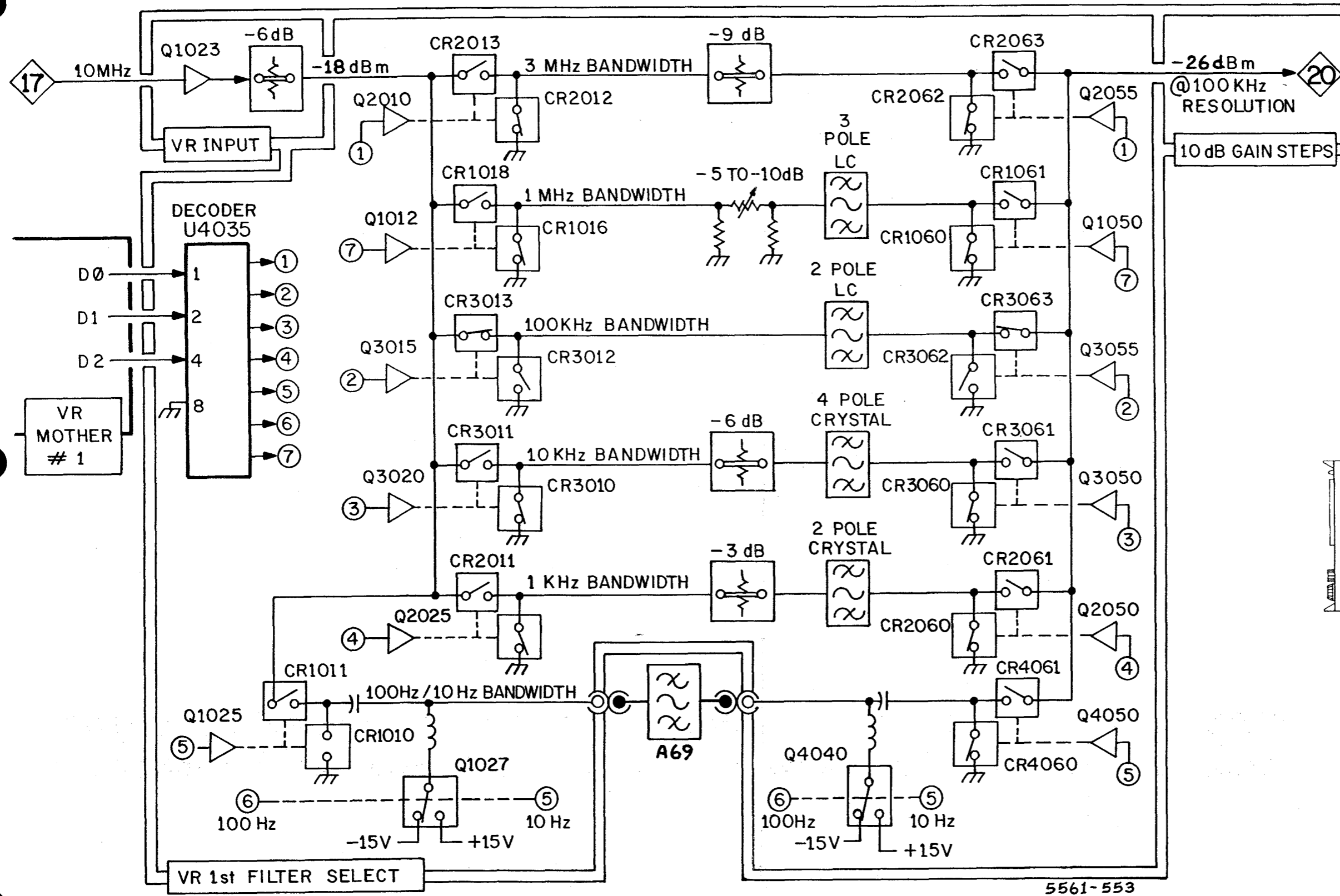

VR INPUT & 1st FILTER SELECT

ASSEMBLY A68A3

CIRCUIT NUMBER	SCHEM LOCATION	BOARD LOCATION	CIRCUIT NUMBER	SCHEM LOCATION	BOARD LOCATION	CIRCUIT NUMBER	SCHEM LOCATION	BOARD LOCATION
C1016	B1	A1	Q1023	B1	B1	R1024	A1	B1
C1019	A1	A1				R1025	A1	B1
C1022	B1	B1	R1014	B1	A1	R1026	A1	B1
C1025	A1	B1	R1015	B1	A1			
C1031	A1	C1	R1016	B1	A1	T1019	B1	A1
			R1022	B1	B1			
L1018	A1	A1	R1023	B1	B1			

ASSEMBLY A68A4

CIRCUIT NUMBER	SCHEM LOCATION	BOARD LOCATION	CIRCUIT NUMBER	SCHEM LOCATION	BOARD LOCATION	CIRCUIT NUMBER	SCHEM LOCATION	BOARD LOCATION	CIRCUIT NUMBER	SCHEM LOCATION	BOARD LOCATION
C1010	C3	A1	C3058	E2	D3	L3015	B2	A3	R2024	C1	A2
C1011	C4	A1	C3060	E2	D3	L3029	B2	B3	R2026	C1	B2
C1012	C1	A1	C3064	E2	D3	L3040	D2	C3	R2027	C1	B2
C1014	C4	A1	C4010	B1	A4	L3056	E3	D3	R2028	B3	B2
C1016	C2	A1	C4030	A3	B4	L3058	E2	D3	R2029	B3	B2
C1018	C4	A1	C4031	A3	B4	L4010	B4	A4	R2050	E3	D2
C1019	C1	A2	C4032	A3	B4	L4015	A1	A4	R2051	E3	D2
C1020	B4	A1	C4033	A2	B4	L4040	A2	C4	R2052	E1	D2
C1022	C4	B1	C4034	A2	B4	L4045	A2	C4	R2053	E1	D2
C1030	D1	B1	C4036	A2	C4	L4050	E4	D4	R2054	E3	D2
C1032	D1	B1	C4037	A2	C4	L4055	E4	D4	R2055	E3	D2
C1034	D1	B1	C4039	A2	C4	L4060	F4	D4	R2056	E3	D2
C1040	D1	C1	C4050	E4	D4	L4061	E4	D4	R2057	E1	D2
C1044	E1	C1	C4051	E4	D4				R2058	E1	D2
C1046	D1	C1	C4053	E4	D4	Q1020	C2	B1	R2059	F1	D2
C1050	D1	D1	C4055	E4	D4	Q1025	C4	B1	R3010	C3	A3
C1052	E1	D1	C4057	E3	D4	Q1027	B4	B1	R3011	C2	A3
C1054	D1	D1	C4059	E4	D4	Q1050	E2	D1	R3012	C3	A3
C1056	E1	D1				Q2010	C1	A2	R3013	B3	A3
C1057	F1	D2	CR1010	B4	A1	Q2025	B3	B2	R3014	B3	A3
C1058	E1	D1	CR1011	B3	A1	Q2050	E3	D2	R3015	B2	A3
C1059	F2	D1	CR1012	C4		Q2053	E1	D2	R3016	B2	A3
C1060	E1	D1	CR1016	C1	A1	Q3015	B2	A3	R3017	B2	A3
C1067	F1	D1	CR1018	B1	A1	Q3020	B3	B3	R3018	B2	A3
C2010	C3	A2	CR1020	C4	A1	Q3050	E3	D3	R3019	B2	A3
C2012	C1	A2	CR1030	B4	B1	Q3055	E2	D3	R3020	B3	A3
C2014	C3	A2	CR1035	B4	B1	Q4040	E4	C4	R3022	B3	B3
C2016	C1	A2	CR1060	F1	D1	Q4050	E4	D4	R3024	B3	B3
C2018	C1	A2	CR1061	F1	D1				R3049	E3	D3
C2020	C3	A2	CR2010	B3	A2	R1010	C1	A1	R3050	E3	D3
C2030	D3	B2	CR2011	B3	A2	R1012	C4	A1	R3051	E3	D3
C2050	E3	D2	CR2012	C1	A2	R1014	C1	A1	R3052	E3	D3
C2052	F1	D2	CR2013	C1	A2	R1015	C1	A1	R3053	E3	D2
C2053	F1	D2	CR2060	F3	D2	R1016	C4	A1	R3054	E2	D3
C2055	E3	D2	CR2061	F3	D2	R1018	C4	A1	R3055	E2	D3
C2056	D3	D2	CR2062	F1	D2	R1019	C2	A1	R3056	E2	D3
C2059	E1	D2	CR2063	F1	D2	R1020	C4	A1	R3057	E2	D3
C3010	C2	A3	CR3010	B3	A3	R1021	C2	A1	R3059	E2	D3
C3012	B3	A3	CR3011	B2	A3	R1022	B4	B1	R4010	B4	A4
C3013	B2	A3	CR3012	B2	A3	R1023	B4	B1	R4012	B4	A4
C3016	B2	A3	CR3013	B2	A3	R1024	C1	B1	R4030	A3	B4
C3018	B2	A3	CR3060	F3	D3	R1025	C4	B1	R4032	A3	B4
C3019	B2	A3	CR3061	F2	D3	R1026	B4	B1	R4048	E4	C4
C3020	B3	B3	CR3062	F2	D3	R1027	C1	B1	R4050	E4	C4
C3029	B2	B4	CR3063	F2	D3				R4051	E4	D4
C3030	C2	B3	CR4050	D4	D4	R1029	C2	B1	R4052	E4	D4
C3031	B2	B3	CR4055	D4	D4	R1030	D1	B1	R4053	D4	D4
C3032	C2	B3	CR4060	F4	D4	R1031	B4	B1	R4054	D4	D4
C3033	C2	B3	CR4061	F3	D4	R1032	B4	B1	R4056	E4	D4
C3034	C2	B3				R1050	E2	C1	R4057	E4	D4
C3035	C2	B3	L1010	C4	A1	R1051	E1	D1	R4058	E4	D4
C3037	C2	B3	L1012	C4	A1	R1053	E2	D1	R4059	E4	D4
C3039	C2	C3	L1018	C1	A2	R1055	E2	D1	R4060	F4	D4
C3040	C2	C3	L1040	D1	C1	R1057	F1	D1	R4062	F4	D4
C3041	D2	C3	L1050	E1	D1	R2010	C3	A2			
C3042	D2	C3	L1052	D1	D1	R2011	C3	A2	S2030	C2	C2
C3045	D2	C3	L1058	F1	D1	R2012	C3	A2			
C3046	D2	C3	L2010	C3	A2	R2014	C3	A2			
C3047	D2	C3	L2018	C1	A2	R2015	D1	A2	T2025	D2	
C3049	D2	C3	L2056	E3	D2	R2016	D1	A2	T2035	C3	B2
C3050	E3	D3	L2058	F1	D2	R2017	D1	A2	T2040	D3	C2
C3052	E3	D3	L3010	B3	A3	R2018	D1	A2	T3040	E2	C3
C3053	D2	D3				R2019	C1	A2			
C3054	E2	D3	Y2030	D2	B2	R2020	B3	A2	U4035	A2	B4
			Y2040	D3	C2	R2021	B3	A2			
			Y2045	D2	C2	R2023	C1	A2			

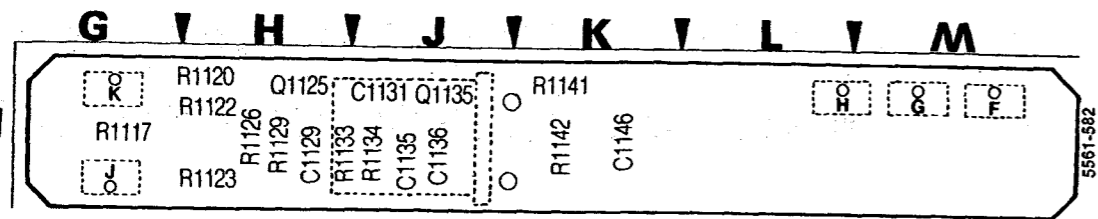
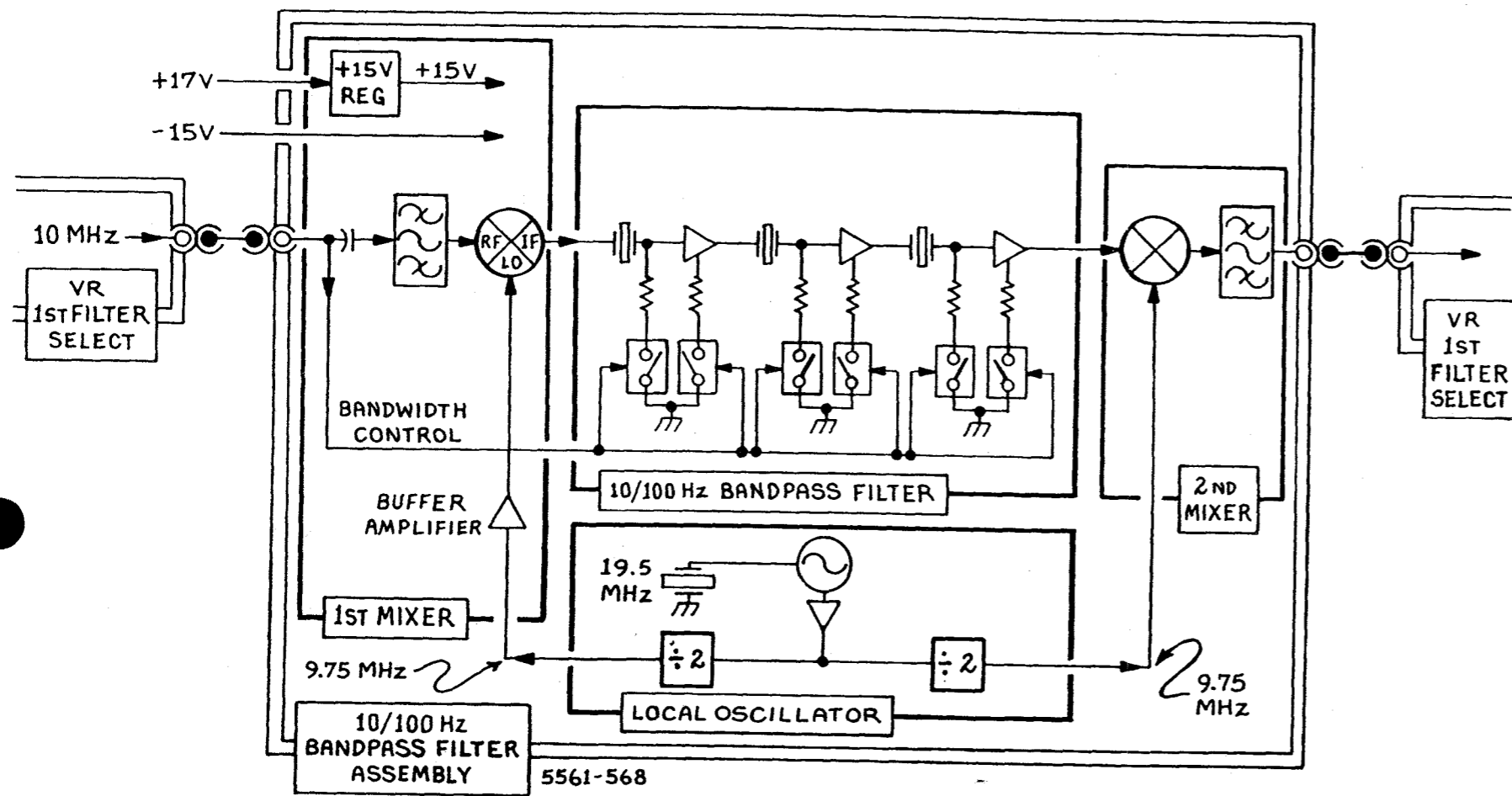
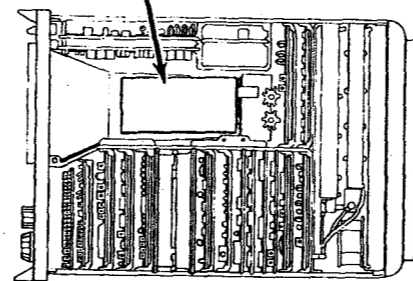

Fig. 10-28 A69A4 — Local Oscillator circuit board (rear)

10 Hz/100 Hz BAND-PASS FILTER ASSEMBLY



5561-569

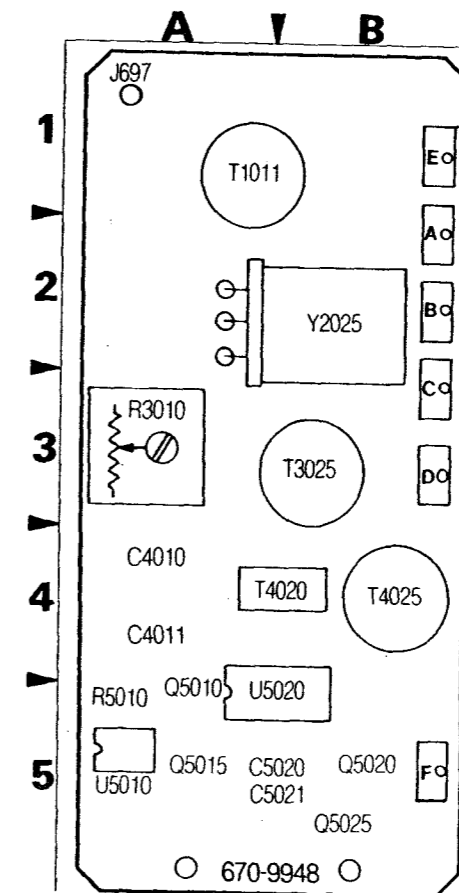

Fig. 10-22 A69A1 — 1st Mixer circuit board (front)

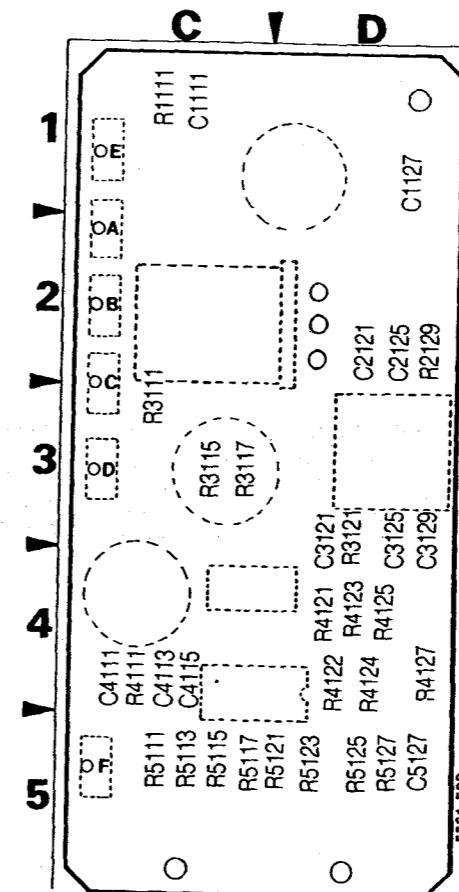

Fig. 10-26 A69A1 — 1st Mixer circuit board (rear)

VR 10 Hz/100 Hz BANDPASS FILTER

ASSEMBLY A69A1

CIRCUIT NUMBER	SCHEM LOCATION	BOARD LOCATION	CIRCUIT NUMBER	SCHEM LOCATION	BOARD LOCATION	CIRCUIT NUMBER	SCHEM LOCATION	BOARD LOCATION	CIRCUIT NUMBER	SCHEM LOCATION	BOARD LOCATION
C1111	A4	C1	Q5010	B1	A5	R4124	A3	D4	T1011	A2	A1
C1127	A2	D1	Q5015	B1	A5	R4125	A3	D4	T3025	A2	B3
C2121	A3	D2	Q5020	A4	B5	R4127	A1	D4	T4020	A2	B4
C2125	A3	D2	Q5025	B4	B5	R5010	B1	A5	T4025	B2	B4
C3121	A3	D3				R5111	B4	C5			
C3125	A3	D3	R1111	A4	C1	R5113	B4	C5	U5010	A1	A5
C3129	A3	D3	R2129	A2	D2	R5115	B4	C5	U5020	B2	B5
C4010	A1	A4	R3010	A3	A3	R5117	B5	C5			
C4011	B1	A4	R3111	A2	C3	R5121	A2	D5	Y2025	A2	B2
C4111	A5	C4	R3115	A2	C3	R5123	A2	D5			
C4113	A4	C4	R3117	A2	C3	R5125	A1	D5			
C4115	A2	C4	R3121	A3	D3	R5127	A1	D5			
C5020	A3	B5	R4111	A5	C4						
C5021	B3	B5	R4121	A3	D4						
C5127	A1	D5	R4122	A3	D4						

ASSEMBLY A69A2

CIRCUIT NUMBER	SCHEM LOCATION	BOARD LOCATION	CIRCUIT NUMBER	SCHEM LOCATION	BOARD LOCATION	CIRCUIT NUMBER	SCHEM LOCATION	BOARD LOCATION	CIRCUIT NUMBER	SCHEM LOCATION	BOARD LOCATION
C1061	D1	F1	C4142	C1	K4	R2067	D2	F2	R4034	C2	C4
C1065	D3	F1	C4144	C1	K4	R2068	D3	F2	R4058	E2	E4
C1066	D1	F1	C4146	C1	K4	R2111	E1	G2	R4059	E3	E4
C1120	D2	H1	C4151	C3	L4	R2121	D3	G2	R4063	E2	F4
C1121	D2	H1	C4156	C3	L4	R2123	D3	G2	R4064	E2	F4
C2061	D1	F2	C4164	B2	M4	R2125	D4	G2	R4065	E3	F4
C2063	D1	F2				R2148	C1	K2	R4113	E3	G4
C2067	D1	F2	CR3060	B4	F3	R2149	C2	K2	R4115	E3	G4
C2111	E1	G2				R2155	C3	L2	R4119	D3	G4
C2122	D3	H2	J3015	B2	A3	R2156	C4	L2	R4121	E2	H4
C2148	C1	K2	J3038	C2	C3	R2160	B2	M2	R4122	E3	H4
C2150	C2	L2	J3052	D2	E3	R2162	B2	M2	R4125	D3	H4
C3048	D2	D3				R2164	B2	M2	R4126	C3	H4
C3062	D1	F3	Q1060	D2	F1	R2166	C4	M2	R4127	D3	H4
C3064	E2	F3	Q1065	D2	F1	R3031	C2	C3	R4131	C3	J4
C3066	D1	F3	Q2060	D2	F2	R3060	D2	F3	R4132	C1	J4
C3116	E1	G3	Q2130	D4	J2	R3061	D1	F3	R4135	C1	J4
C3118	E2	G3	Q2150	C4	L2	R3062	D1	F3	R4136	C1	J4
C3125	E1	H3	Q3065	D1	F3	R3064	D1	F3	R4137	C1	J4
C3128	D2	H3	Q3110	E4	G3	R3066	D1	F3	R4143	C1	K4
C3133	D3	J3	Q3155	C2	L3	R3067	D1	F3	R4144	C1	K4
C3146	C2	K3	Q4060	E2	F4	R3110	E1	G3	R4145	C1	K4
C3149	C2	K3	Q4110	E2	G4	R3112	E1	G3	R4149	C3	K4
C3152	B2	L3	Q4120	E2	H4	R3114	E4	G3	R4152	C1	L4
C4015	B3	A4	Q4125	E3	H4	R3116	E4	G3	R4153	B3	L4
C4028	C2	B4	Q4130	D3	J4	R3118	E2	G3	R4161	B3	M4
C4032	C3	C4	Q4140	C1	K4	R3125	E1	H3	R4163	B3	M4
C4036	C2	C4	Q4145	C2	K4	R3126	E1	H3			
C4038	C2	C4	Q4150	C2	L4	R3127	D4	H3	T3016	B2	A3
C4045	D2	D4	Q4155	C3	L4	R3131	B4	J3			
C4051	D2	E4				R3133	C3	J3	Y2020	B2	B2
C4059	E3	E4	R1060	D2	F1	R3135	D3	J3	Y2030	C2	C2
C4060	E2	F4	R1061	D3	F1	R3136	C1	J3	Y2050	D2	E2
C4065	E3	F4	R1065	D1	F1	R3140	D3	K3			
C4068	E2	F4	R1067	D1	F1	R3156	C3	L3			
C4111	E3	G4	R1068	D1	F1	R3160	C2	M3			
C4115	E2	G4	R1121	D2	H1	R3162	C3	M3			
C4120	E3	H4	R2061	D2	F2	R4026	B3	B4			
C4133	C1	J4	R2062	D1	F2	R4027	C2	B4			
C4134	C1	J4	R2064	D1	F2	R4029	C3	B4			

ASSEMBLY A69A3

CIRCUIT NUMBER	SCHEM LOCATION	BOARD LOCATION	CIRCUIT NUMBER	SCHEM LOCATION	BOARD LOCATION	CIRCUIT NUMBER	SCHEM LOCATION	BOARD LOCATION	CIRCUIT NUMBER	SCHEM LOCATION	BOARD LOCATION
C1021	F2	B1	R3025	F3	B3	R5025	F1	B5	T4025	F2	B4
C5012	F3	A5	R4021	F3	B4						
C5014	F3	A5	R5018	F3	A5	T1022	F2	B1	U5022	F2	B5
C5024	F1	B5	R5019	F3	A5	T3015	F2	A3			
C5026	F3	B5	R5023	F1	B5	T4016	F2	A4	Y2020	F2	B2

ASSEMBLY A69A4

CIRCUIT NUMBER	SCHEM LOCATION	BOARD LOCATION	CIRCUIT NUMBER	SCHEM LOCATION	BOARD LOCATION	CIRCUIT NUMBER	SCHEM LOCATION	BOARD LOCATION	CIRCUIT NUMBER	SCHEM LOCATION	BOARD LOCATION
C1010	B4	A1	C1135	D5	J1	R1117	E4	G1	R1134	D5	J1
C1012	B4	A1	C1136	D5	J1	R1120	E4	H1	R1141	D4	K1
C1021	C4	B1	C1146	C5	K1	R1122	D4	H1	R1142	D5	K1
C1025	C4	B1				R1123	D4	H1			
C1129	D5	H1	Q1125	D5	H1	R1126	D5	H1	U1021	B4	B1
C1032	C5	C1	Q1135	D5	J1	R1129	D5	H1	U1055A	C5	E1
C1131	D5	J1				R1133	D5	J1	U1055B	E5	E1
			R1010	B4	A1						
									Y1040	C5	D1

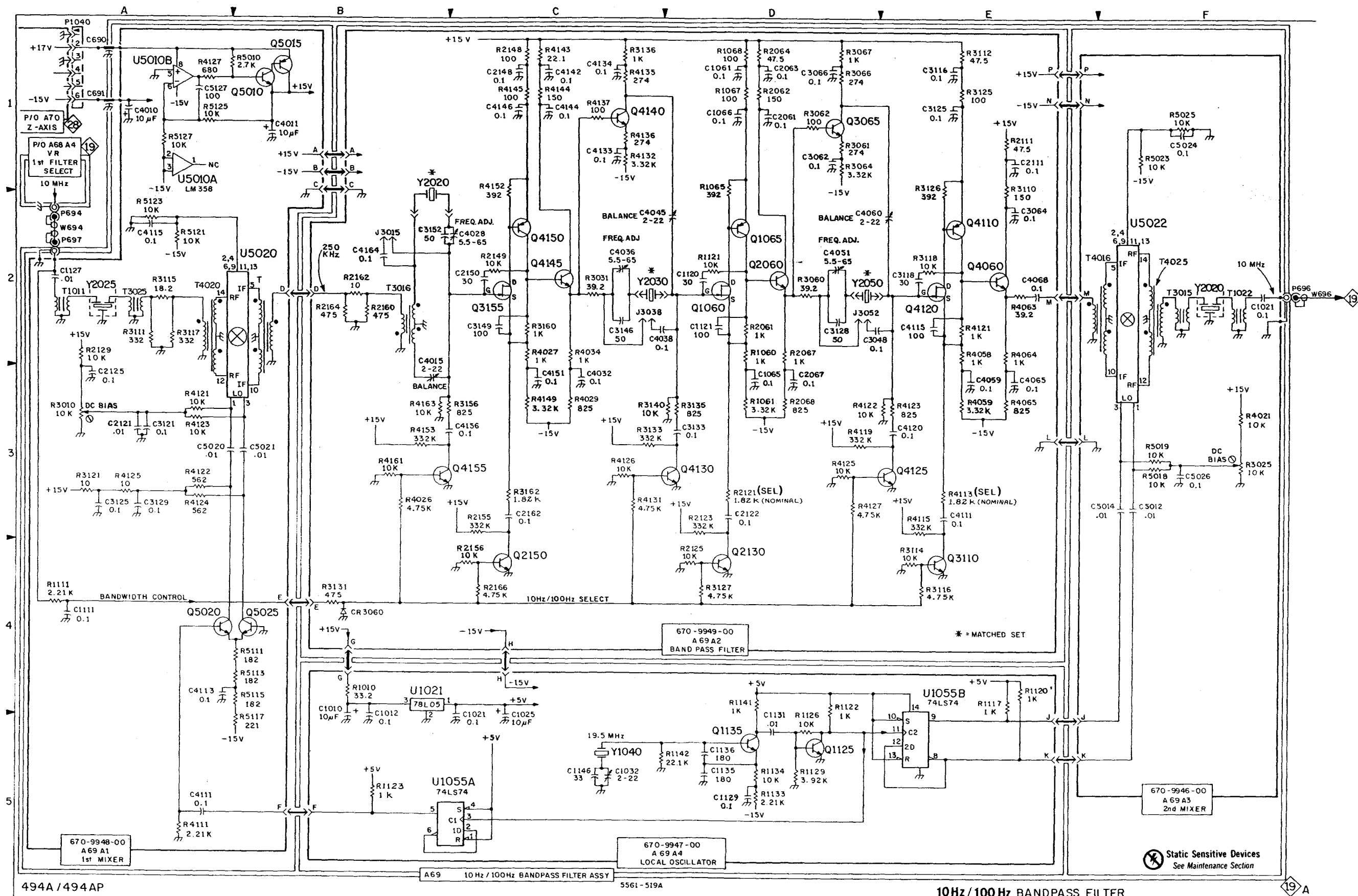

494A / 494AP

A69 10 Hz / 100 Hz BANDPASS FILTER ASSY

5561-519A

10 Hz / 100 Hz BANDPASS FILTER

⚡ Static Sensitive Devices
See Maintenance Section

19 A

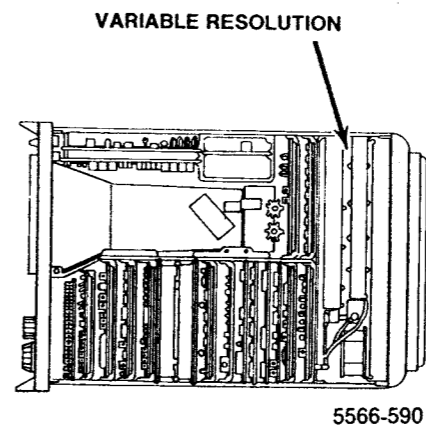
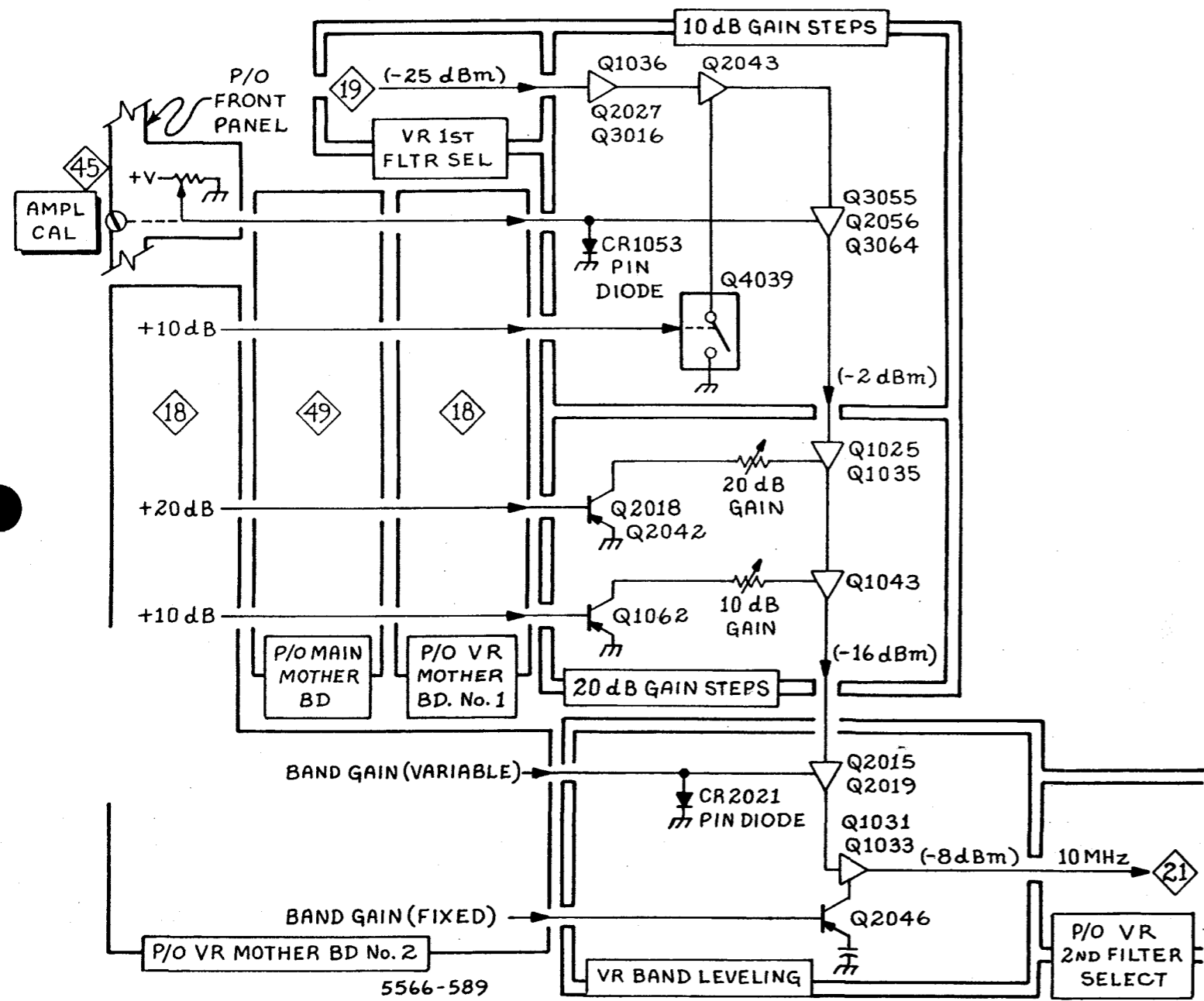

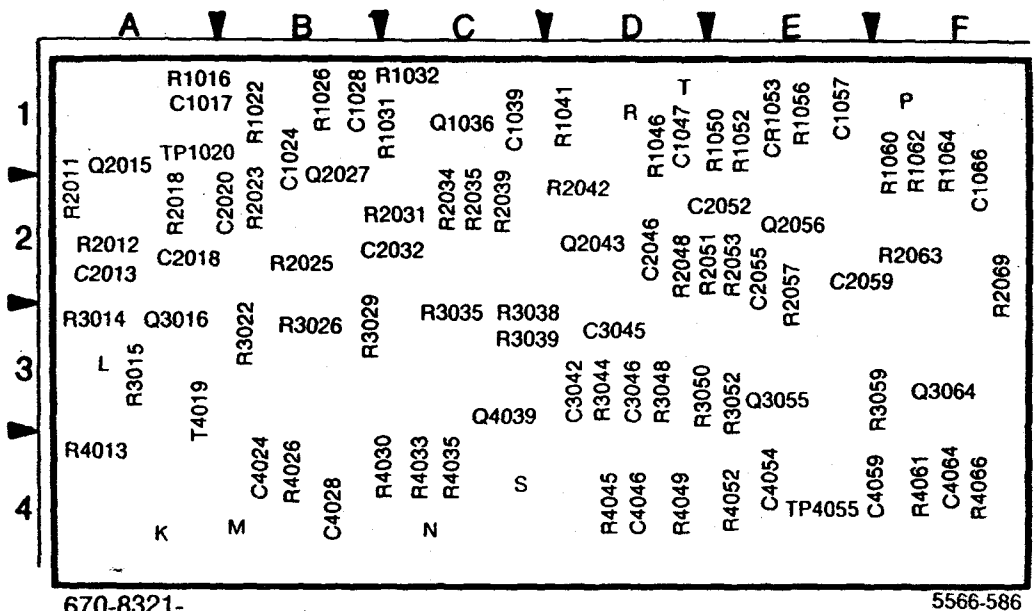

670-8321-

Fig. 10-29. A68A5—VR 10dB Gain Steps circuit board.

5566-586

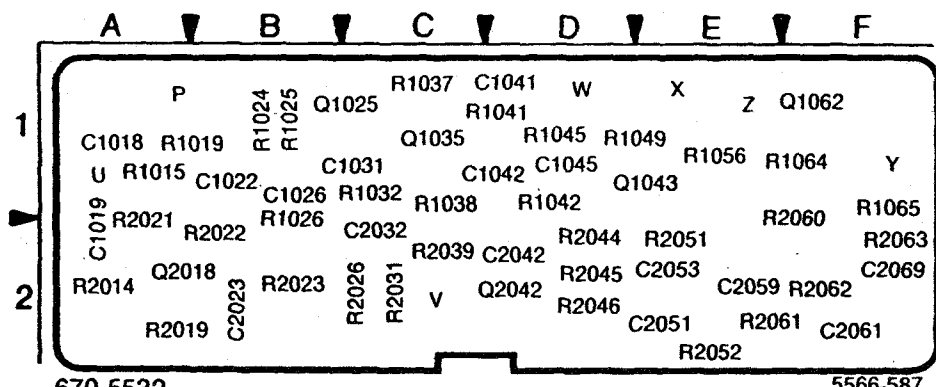

670-5532-

Fig. 10-30. A68A6—VR 20 dB Gain Steps circuit board.

5566-587

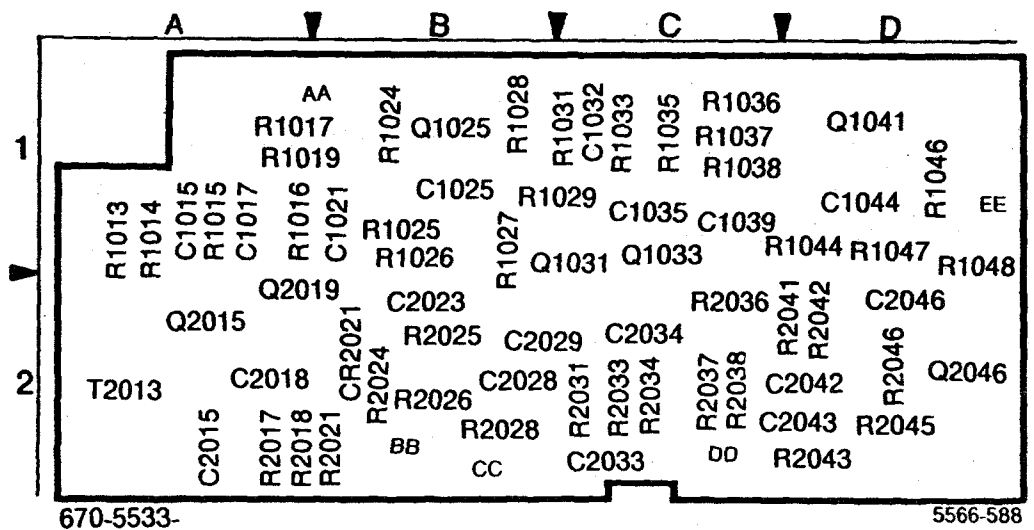

670-5533-

Fig. 10-31. A68A7—VR Band Leveling circuit board.

5566-588

10dB GAIN, 20dB GAIN, & BAND LEVELING



ASSEMBLY A68A5

CIRCUIT NUMBER	SCHEM LOCATION	BOARD LOCATION	CIRCUIT NUMBER	SCHEM LOCATION	BOARD LOCATION	CIRCUIT NUMBER	SCHEM LOCATION	BOARD LOCATION	CIRCUIT NUMBER	SCHEM LOCATION	BOARD LOCATION
C1017	B1	A1	CR1053	D2	E1	R1064	D1	F1	R3039	C2	C3
C1024	A1	B1				R2011	B2	A2	R3044	C2	D3
C1028	B1	B1	Q1036	B1	C1	R2012	A2	A2	R3048	C1	D3
C1039	B1	C1	Q2015	B2	A1	R2018	B2	A2	R3050	C1	D3
C1047	D2	D1	Q2027	B1	B2	R2023	B1	B2	R3052	C1	E3
C1057	D1	E1	Q2043	C1	D2	R2025	B2	B2	R3059	C1	E3
C1066	D1	F2	Q2056	D1	E2	R2031	B1	C2	R4013	A1	A4
C2013	A2	A2	Q3016	B1	A2	R2034	B1	C2	R4026	B2	B4
C2018	B1	A2	Q3055	C1	E3	R2035	B1	C2	R4030	A2	B4
C2020	A1	B2	Q3064	D1	F3	R2039	C1	C2	R4033	A2	C4
C2032	B1	C2	Q4039	C2	C3	R2042	C1	D1	R4035	C2	C4
C2046	C1	D1				R2048	C1	D1	R4045	C1	D4
C2052	D2	E2	R1016	B1	A1	R2051	C1	D1	R4049	C1	D4
C2055	C1	E2	R1022	A1	B1	R2053	D1	E2	R4052	C2	E4
C2059	D1	E2	R1026	B1	B1	R2057	D1	E2	R4061	C1	F4
C3042	C2	D3	R1031	B1	C1	R2063	D1	F2	R4066	D1	F4
C3045	C1	D3	R1032	B1	C1	R2069	D1	F2			
C3046	C1	D3	R1041	B1	D1	R3014	A2	A2	T4019	A1	A2
C4024	B2	B4	R1046	D2	D1	R3015	A1	A2			
C4028	A2	B4	R1050	D2	E1	R3022	B1	B3	TP1020	A1	A1
C4046	C1	D4	R1052	D2	E1	R3026	B1	B3	TP4055	C2	E4
C4054	C2	E4	R1056	D1	E1	R3029	B1	B3			
C4059	C1	E4	R1060	D1	F1	R3035	C2	C3			
C4064	C1	F4	R1062	D1	F1	R3038	C2	C3			

ASSEMBLY A68A6

CIRCUIT NUMBER	SCHEM LOCATION	BOARD LOCATION	CIRCUIT NUMBER	SCHEM LOCATION	BOARD LOCATION	CIRCUIT NUMBER	SCHEM LOCATION	BOARD LOCATION	CIRCUIT NUMBER	SCHEM LOCATION	BOARD LOCATION
C1018	A3	A1	C2061	C3	F2	R1026	B3	B2	R2022	B3	B2
C1019	A3	A2	C2069	C4	F2	R1032	B3	C1	R2023	B3	B2
C1022	B3	B1				R1037	C3	C1	R2026	B3	C2
C1026	A3	B1	Q1025	B3	B1	R1038	C4	C1	R2031	B3	C2
C1031	B3	C1	Q1035	C3	C1	R1041	C3	D1	R2039	B3	C2
C1041	B3	D1	Q1043	C3	E1	R1042	C3	D1	R2044	C3	D2
C1042	C3	D1	Q1062	C4	F1	R1045	C3	D1	R2045	B3	D2
C1045	C3	D1	Q2018	B3	A2	R1049	C3	D1	R2046	B3	D2
C2023	B4	B2	Q2042	B3	D2	R1056	C3	E1	R2051	C3	E2
C2032	B4	C2				R1064	C4	F1	R2052	C3	E2
C2042	B3	D2	R1015	B3	A1	R1065	C4	F2	R2060	C3	F2
C2051	D3	E2	R1019	A3	A1	R2014	B3	A2	R2061	C3	E2
C2053	B3	E2	R1024	B3	B1	R2019	B3	A2	R2062	C3	F2
C2059	C3	E2	R1025	B3	B1	R2021	B3	A2	R2063	C4	F2

ASSEMBLY A68A7

CIRCUIT NUMBER	SCHEM LOCATION	BOARD LOCATION	CIRCUIT NUMBER	SCHEM LOCATION	BOARD LOCATION	CIRCUIT NUMBER	SCHEM LOCATION	BOARD LOCATION	CIRCUIT NUMBER	SCHEM LOCATION	BOARD LOCATION
C1015	E2	A1	CR2021	E3	B2	R1026	E2	B1	R2025	E3	B2
C1017	E1	A1				R1027	E2	B1	R2026	E3	B2
C1021	E2	B1	Q1025	E2	B1	R1028	E2	B1	R2028	E3	B2
C1025	E2	B1	Q1031	F2	C1	R1029	E2	B1	R2031	F2	C2
C1032	E2	C1	Q1033	F2	C1	R1031	E2	C1	R2033	E2	C2
C1035	E1	C1	Q1041	F1	D1	R1033	E1	C1	R2034	F2	C2
C1039	F2	C1	Q2015	E2	A2	R1035	F1	C1	R2036	F2	C2
C1044	F1	D1	Q2019	E2	A2	R1036	E1	C1	R2037	F3	C2
C2015	E3	A2	Q2046	F3	D2	R1037	F1	C1	R2038	F3	C2
C2018	E2	A2				R1038	F2	C1	R2041	F3	D2
C2023	E3	B2	R1013	E2	A1	R1044	F1	D1	R2042	F2	D2
C2028	E3	B2	R1014	E2	A1	R1046	F2	D1	R2043	E3	D2
C2029	E3	B2	R1015	E2	A1	R1047	F1	D1	R2045	E3	D2
C2033	E2	C2	R1016	E2	A1	R1048	F2	D1	R2046	F3	D2
C2034	F2	C2	R1017	E1	A1	R2017	E2	E2			
C2043	F3	D2	R1019	E1	A1	R2018	E2	E2	T2013	E2	A2
C2044	E3	D2	R1024	E1	B1	R2021	E3	B2			
C2046	F2	D2	R1025	E2	B1	R2024	E3	B2			

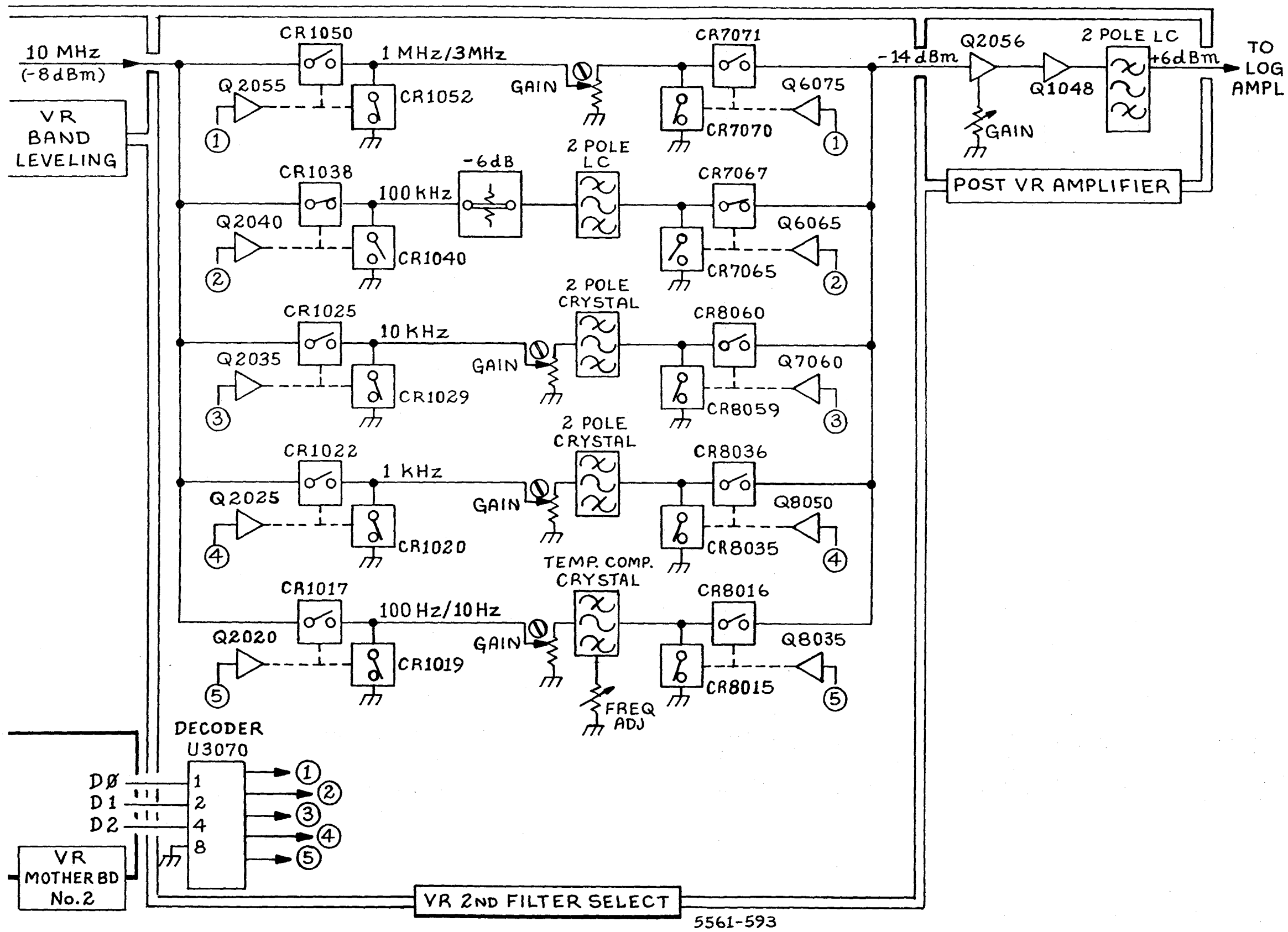

VARIABLE RESOLUTION

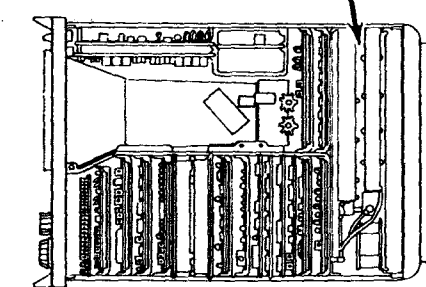

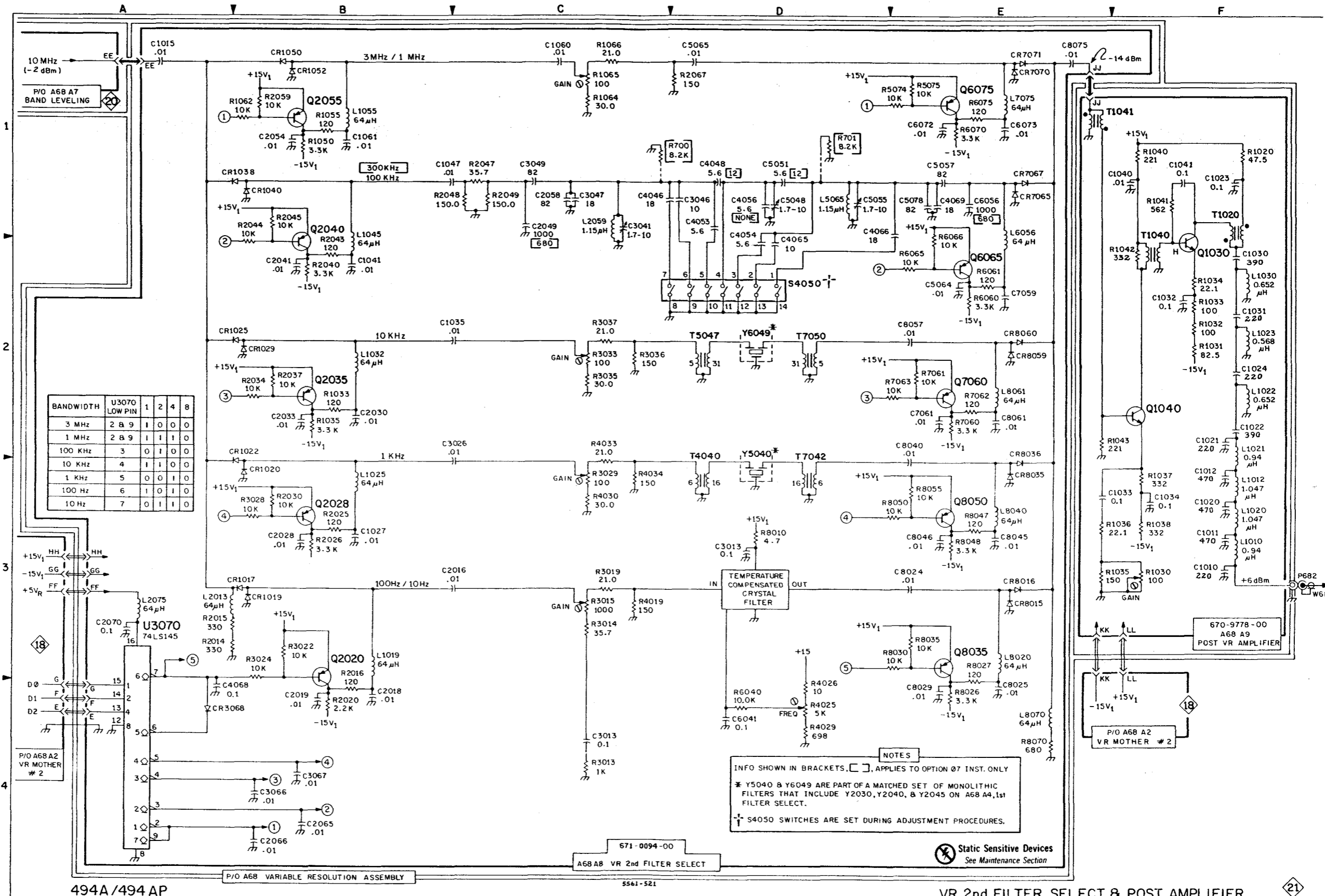

494A/494 AP

671-0094-00
A68 A9 VR 2nd FILTER SELECT

5541-521

Static Sensitive Devices
See Maintenance Section

VR 2nd FILTER SELECT & POST AMPLIFIER

21

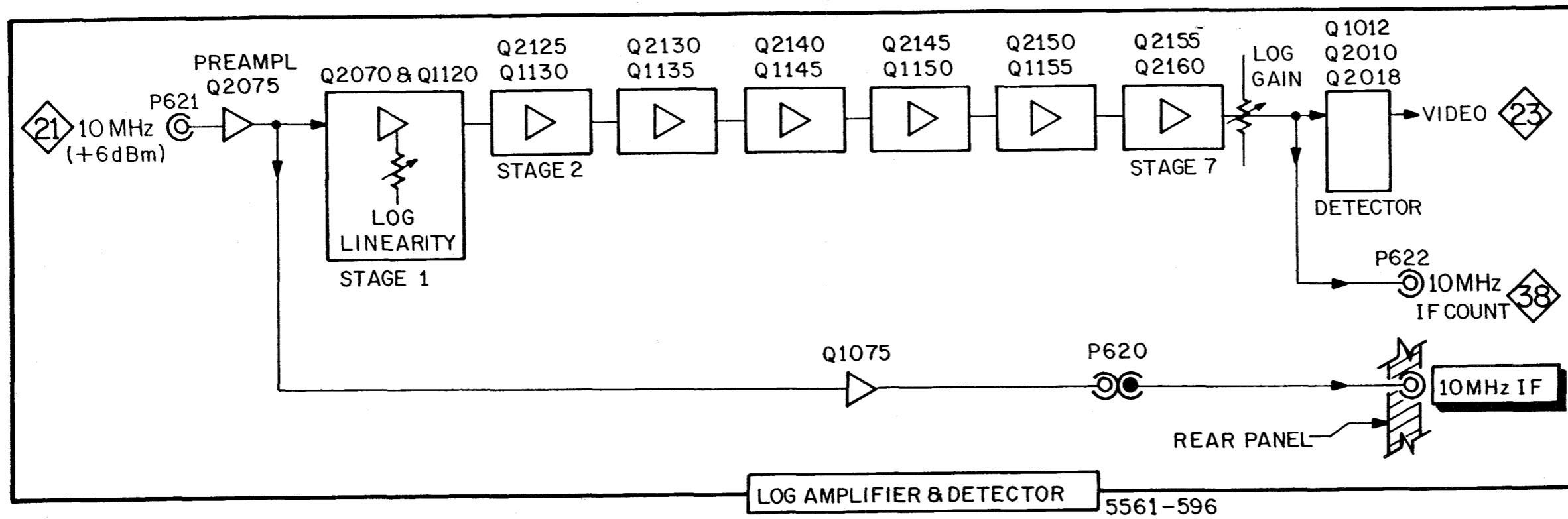

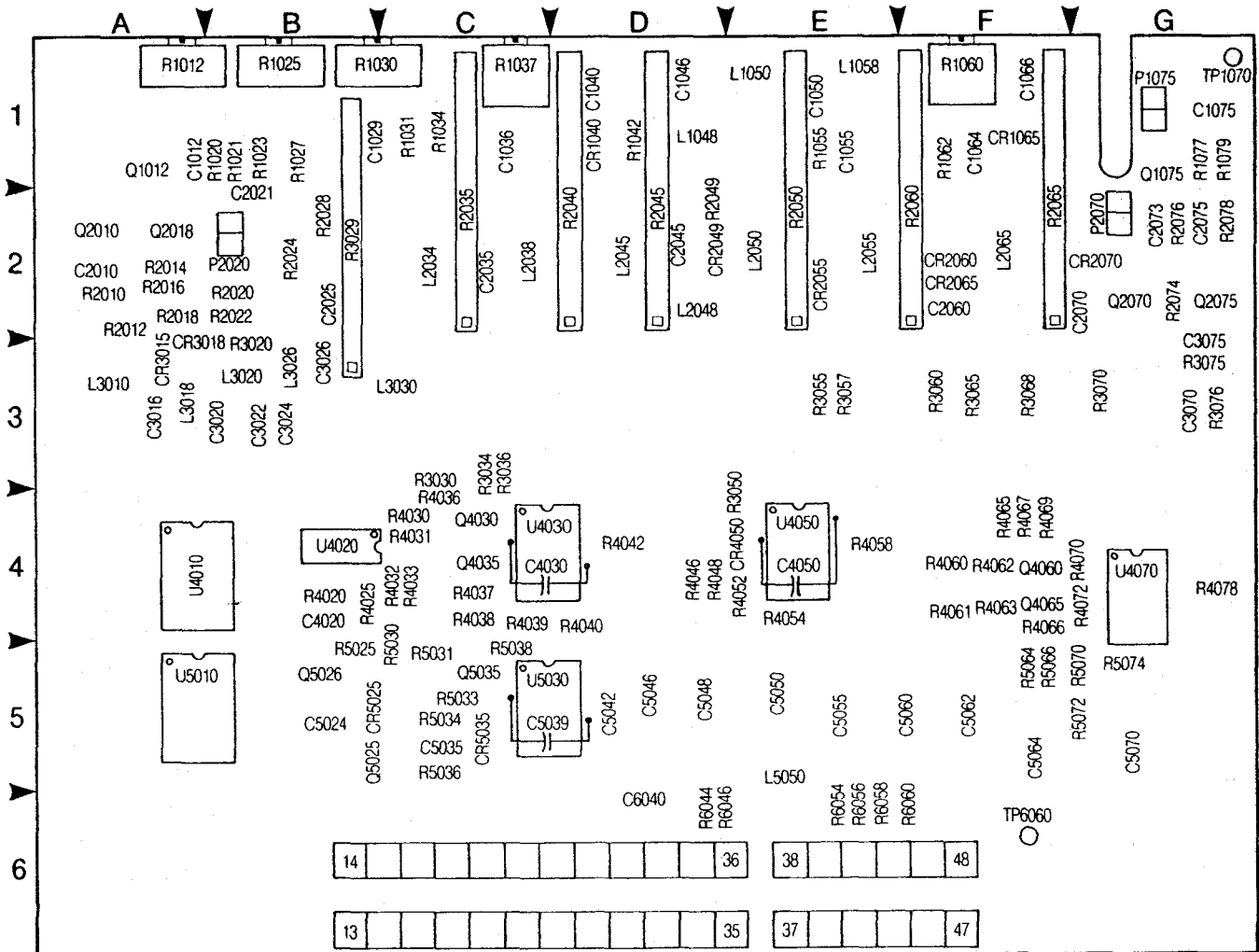
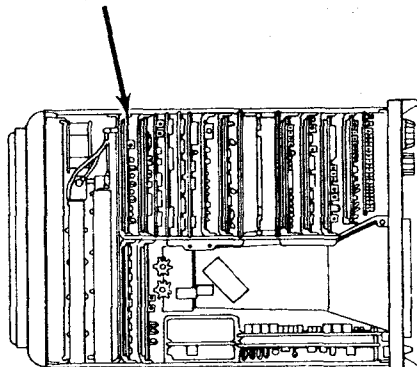

Fig. 10-34. A62A1—Log Amplifier circuit board (front).

LOG & VIDEO AMPLIFIER



**LOG AMPLIFIER & DETECTOR
ASSEMBLY A62A1 (FRONT)**

CIRCUIT NUMBER	SCHEM LOCATION	BOARD LOCATION	CIRCUIT NUMBER	SCHEM LOCATION	BOARD LOCATION	CIRCUIT NUMBER	SCHEM LOCATION	BOARD LOCATION	CIRCUIT NUMBER	SCHEM LOCATION	BOARD LOCATION
C1012	E4	A1	CR2070	B1	G2	R1042	A3	D1	R4039	K2	C4
C1029	D3	B1	CR3015	F4	A3	R1055	D1	E1	R4040	L4	D4
C1036	C3	C1	CR3018	F3	A3	R1060	C1	F1	R4042	L4	D4
C1040	B3	D1	CR4050	J4	E4	R1062	C1	F1	R4046	H4	D4
C1046	A3	D1	CR5025	L1	B5	R1077	B2	G1	R4048	J4	D4
C1050	F2	E1	CR5035	L2	C5	R1079	B2	G1	R4052	J4	E4
C1055	D1	E1	L1048	F2	D1	R2010	F3	A2	R4054	M4	E4
C1064	C1	F1	L1050	F1	E1	R2012	F4	A2	R4058	M4	E4
C1066	C1	F1	L1058	F2	E1	R2014	F3	A2	R4060	L2	F4
C1075	A2	G1	L2034	D3	C2	R2016	F3	A2	R4061	L2	F4
C2010	F3	A2	L2038	C3	C2	R2018	F4	A2	R4062	L2	F4
C2021	E3	B2	L2045	B3	D2	R2020	E4	B2	R4063	L2	F4
C2025	D4	B2	L2048	F1	D2	R2022	F4	B2	R4065	K2	F4
C2035	C4	C2	L2050	F2	E2	R2024	D4	B2	R4066	L5	F4
C2045	A4	D2	L2055	D1	E2	R2028	D4	B2	R4067	K2	F4
C2060	D1	F2	L2065	C1	F2	R2035	C3	C2	R4069	K2	F4
C2070	B1	G2	L3010	H4	A3	R2040	B3	D2	R4070	K4	G4
C2073	A1	G2	L3018	H4	A3	R2045	A3	D2	R4072	K4	G4
C2075	B2	G2	L3020	G4	B3	R2049	E1	D2	R4078	L5	G4
C3016	H4	A3	L3026	G4	B3	R2050	E1	E2	R5025	M1	B5
C3020	G4	B3	L3030	F1	C3	R2060	D1	F2	R5030	L1	C5
C3022	G4	B3	L5050	G1	E5	R2065	C1	F2	R5031	M1	C5
C3024	G4	B3				R2074	B1	G2	R5033	L2	C5
C3026	D3	B3	P1075	A2	G1	R2076	B2	G2	R5034	L2	C5
C3070	B1	G3	P2020	F4	B2	R2078	B2	G2	R5036	M1	C5
C3075	B1	G3	P2070	A1	G2	R3020	F3	B3	R5038	K2	C5
C4020	L3	B4				R3029	D3	B3	R5064	K2	F5
C4030	K2	C4	Q1012	E3	A1	R3030	J2	C3	R5066	K2	F5
C4050	J4	E4	Q1075	B2	G1	R3034	J2	C3	R5070	K4	G5
C5024	M1	B5	Q2010	E3	A2	R3036	J2	C3	R5072	K4	G5
C5035	L2	C5	Q2018	F3	A2	R3050	J4	E3	R5074	L5	G5
C5039	L1	C5	Q2070	B1	G2	R3055	E1	E3	R6044	G1	D6
C5042	M5	D5	Q2075	B1	G2	R3057	E2	E3	R6046	G1	D6
C5046	G1	D5	Q4030	J2	C4	R3060	D1	F3	R6054	G1	E6
C5048	G1	D5	Q4035	J2	C4	R3065	D2	F3	R6056	G1	E6
C5050	G1	E5	Q4060	L2	F4	R3068	C2	F3	R6058	G1	E6
C5055	G1	E5	Q4065	L2	F4	R3070	C2	G3	R6060	G2	F6
C5060	G2	F5	Q5025	M1	B5	R3075	B1	G3			
C5062	G2	F5	Q5028	M1	B5	R3076	B1	G3	TP1070	A2	G1
C5064	G2	F5	Q5035	K2	C5	R4020	L3	B4	TP6060	M1	F6
C5070	G2	G5				R4025	J1	B4			
C6040	G1	D6	R1012	J3	A1	R4030	J2	C4	U4010	H1	A4
			R1020	E3	B1	R4031	J2	C4	U4020A	H2	B4
CR1040	B3	D1	R1021	E3	B1	R4032	J1	C4	U4020B	H2	B4
CR1065	B1	F1	R1023	E3	B1	R4033	J2	C4	U4020C	H1	B4
CR2049	E2	D2	R1025	K4	B1	R4036	J2	C4	U4020D	H1	B4
CR2055	E2	E2	R1027	D3	B1	R4037	J2	C4	U4030	K3	C4
CR2060	D2	F2	R1030	L2	C1	R4038	J2	C4	U4050	M4	E4
CR2065	D2	F2	R1031	C3	C1				U4070	L5	G4
			R1034	C3	C1				U5010	H3	A5
			R1037	E3	C1				U5030	M5	C5

Partial A62A1 is also shown on diagram 23

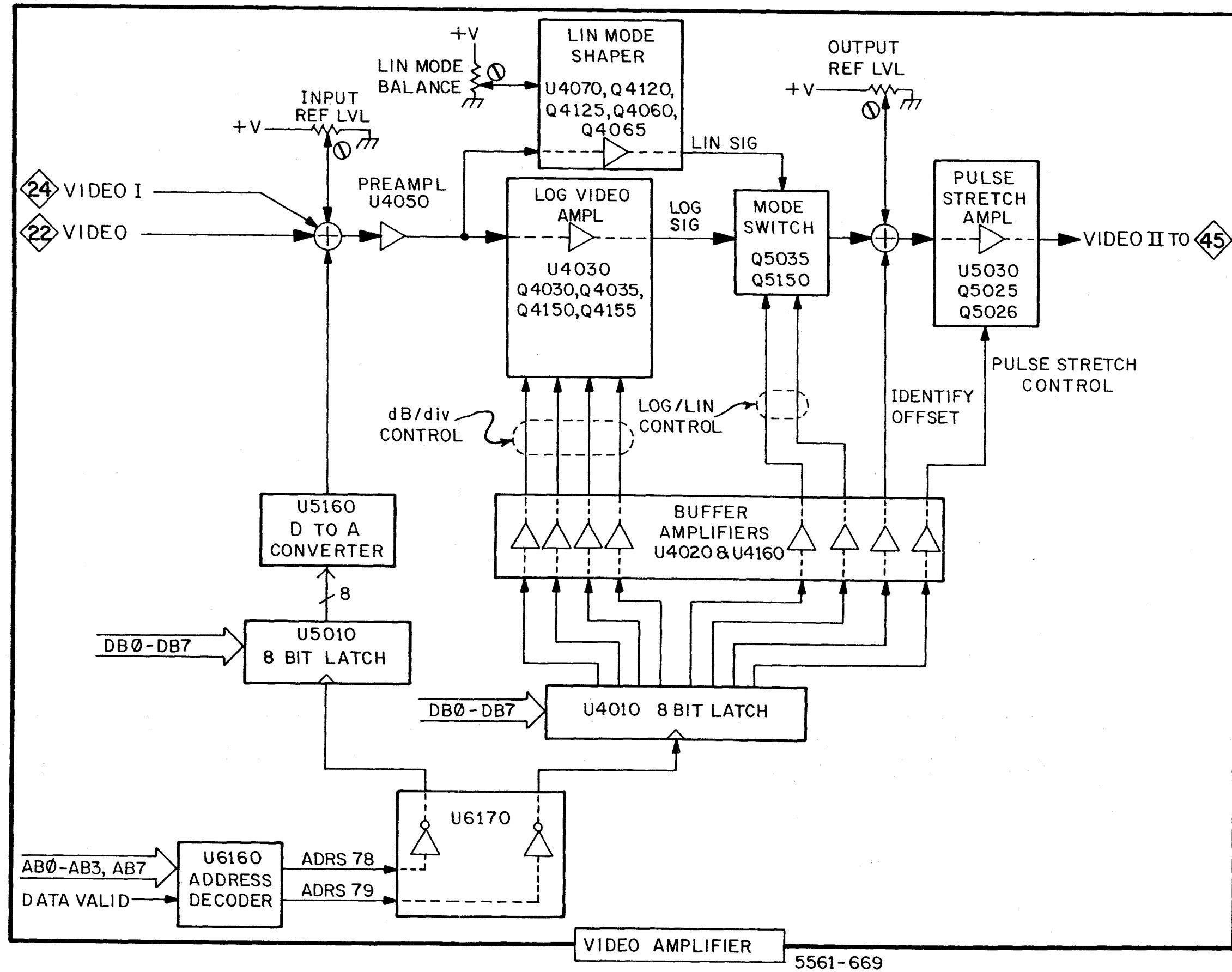

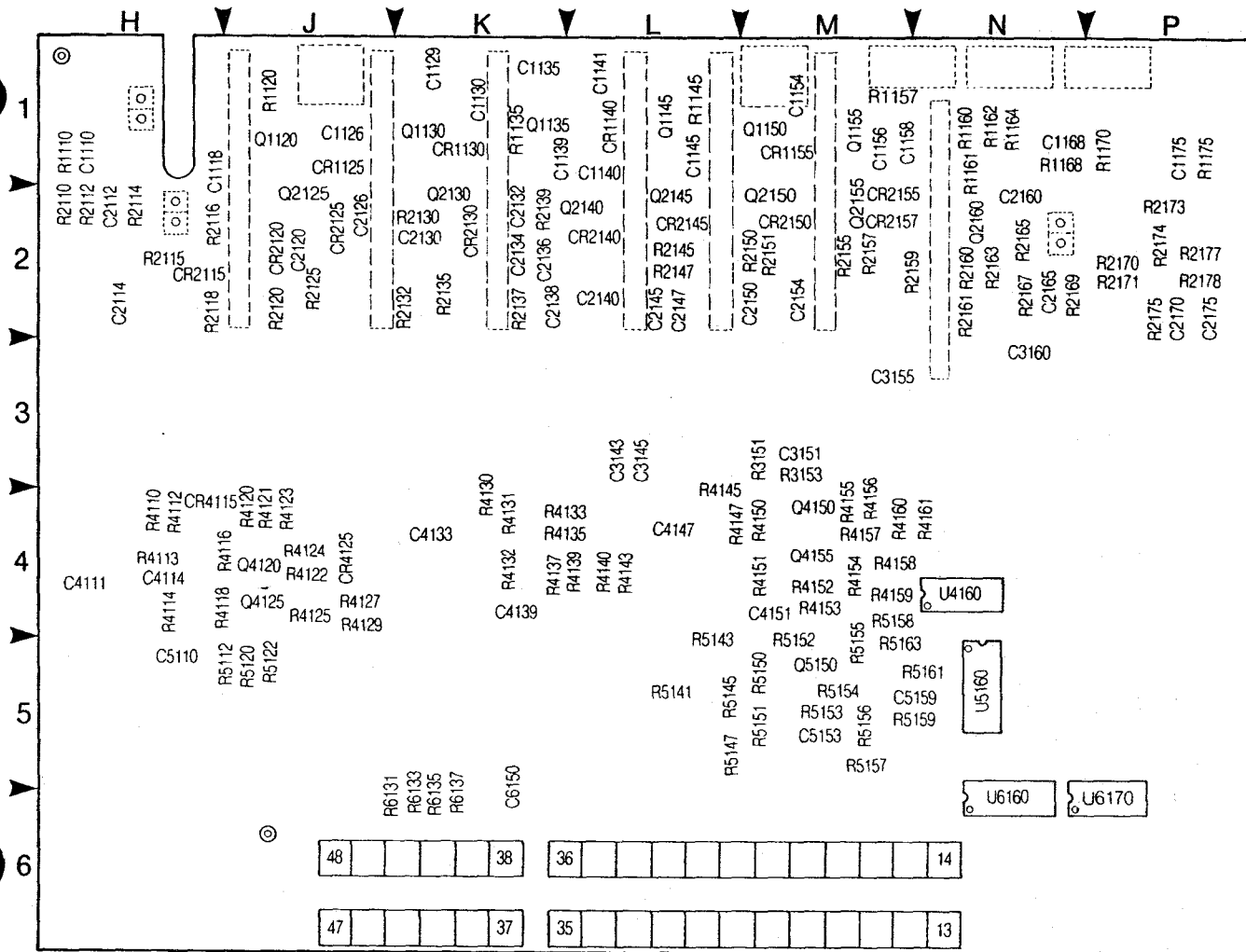

670-9091-01

Fig. 10-35. A62A1—Log Amplifier circuit board (rear).

LOG & VIDEO AMPLIFIER

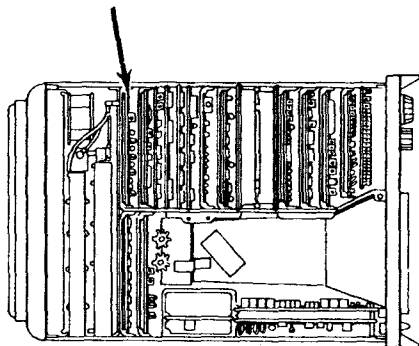

5566-670

**VIDEO AMPLIFIER
ASSEMBLY A62A1 (REAR)**

CIRCUIT NUMBER	SCHEM LOCATION	BOARD LOCATION	CIRCUIT NUMBER	SCHEM LOCATION	BOARD LOCATION	CIRCUIT NUMBER	SCHEM LOCATION	BOARD LOCATION	CIRCUIT NUMBER	SCHEM LOCATION	BOARD LOCATION
C1110	B1	H1				R1168	E3	N1	R4129	L4	J4
C1118	B2	H1	CR1125	D1	J1	R1170	E3	P1	R4130	J4	K4
C1126	D1	J1	CR1130	E1	K1	R1175	E3	P1	R4131	J4	K4
C1129	F2	K1	CR1140	A3	L1	R2110	B1	H2	R4132	J4	K4
C1130	E1	K1	CR1155	C3	M1	R2112	B1	H2	R4133	J4	K4
C1135	F1	K1	CR2115	B2	H2	R2114	A1	H2	R4135	J4	K4
C1139	F2	K1	CR2120	C2	J2	R2115	B1	H2	R4137	J3	K4
C1140	F2	L1	CR2125	C1	J2	R2116	B2	H2	R4139	J3	K4
C1141	F2	L1	CR2130	E1	K2	R2118	C2	H2	R4140	J4	L4
C1145	B3	L1	CR2140	A3	L2	R2120	C2	J2	R4143	J4	L4
C1154	C3	M1	CR2145	B3	L2	R2125	D2	J2	R4145	J3	L4
C1156	D3	M1	CR2150	C3	M2	R2130	D2	K2	R4147	J3	L4
C1158	E3	M1	CR2155	D3	M2	R2132	D2	K2	R4150	J3	M4
C1168	E3	N1	CR2157	D3	M2	R2135	E2	K2	R4151	K3	M4
C1175	E3	P1	CR4115	K3	H4	R2137	E2	K2	R4152	J2	M4
C2112	B1	H2	CR4125	L4	J4	R2139	E2	K2	R4153	J1	M4
C2114	B1	H2				R2145	A4	L2	R4154	J2	M4
C2120	C2	J2				R2147	A4	L2	R4155	J2	M4
C2126	C2	J2				R2150	B4	M2	R4156	J2	M4
C2130	D2	K2	Q1120	C1	J1	R2151	B4	M2	R4157	J2	M4
C2132	D2	K2	Q1130	D1	K1	R2155	C4	M2	R4158	J2	M4
C2134	E2	K4	Q1135	E1	K1	R2157	C4	M2	R4159	J1	M4
C2136	F1	K2	Q1145	B3	L1	R2159	D4	M2	R4160	H1	M4
C2138	E1	K2	Q1150	C3	M1	R2160	D4	N2	R4161	H2	N4
C2140	F1	L2	Q1155	D3	M1	R2161	E4	N2	R5112	L4	H5
C2145	A3	L2	Q2125	C1	J2	R2163	D4	N2	R5120	K2	J5
C2147	B4	L2	Q2130	D1	K2	R2165	E4	N2	R5122	K2	J5
C2150	B3	M2	Q2140	A3	L2	R2167	F3	N2	R5141	M5	L5
C2154	C3	M2	Q2145	B3	L2	R2169	F4	N2	R5143	K1	L5
C2160	E4	N2	Q2150	C3	M2	R2170	F3	P2	R5147	L2	L5
C2165	F3	N2	Q2155	D3	M2	R2171	E2	P2	R5150	L1	M5
C2170	F4	P2	Q2160	E3	N2	R2173	E3	P2	R5152	L1	M5
C2175	E3	P2	Q4120	L3	J4	R2174	E3	P2	R5153	M5	M5
C3143	J4	L3	Q4125	L2	J4	R2175	F4	P2	R5154	J1	M5
C3145	J4	L3	Q4150	J2	M4	R2177	E3	P2	R5155	J1	M5
C3151	J2	M3	Q4155	J2	M4	R2178	E2	P2	R5156	M1	M5
C3155	F1	M3	Q5150	L1	M5	R3151	J3	M3	R5157	J3	M5
C3160	E4	N3				R3153	J2	M3	R5158	J1	M4
C4111	L5	H4				R4110	K3	H4	R5159	J3	M5
C4114	K4	H4				R4112	K3	H4	R5161	J3	M5
C4133	M4	K4				R4113	K5	H4	R5163	H3	M5
C4139	M4	K4				R4114	K4	H4	R6131	G2	J6
C4147	L4	L4	R1110	B1	H1	R4116	K5	H4	R6133	G2	K6
C4151	L4	M4	R1120	C1	J1	R4118	K4	H4	R6135	G1	K6
C5110	L5	H5	R1135	E1	K1	R4120	K3	J4	R6137	G1	K6
C5153	M5	M5	R1145	B3	L1	R4121	K3	J4			
C5159	H3	M5	R1157	E3	M1	R4122	K4	J4	U4160A	H1	N4
C6150	G1	K6	R1160	D3	N1	R4123	K3	J4	U4160B	H1	N4
			R1161	E4	N1	R4124	L3	J4	U4160C	H2	N4
			R1162	D3	N1	R4125	L3	J4	U4160D	H2	N4
			R1164	D3	N1	R4127	L3	J4	U6160	G2	N6
									U6170	H2	P6

Partial A62A1 is also shown on diagram 22

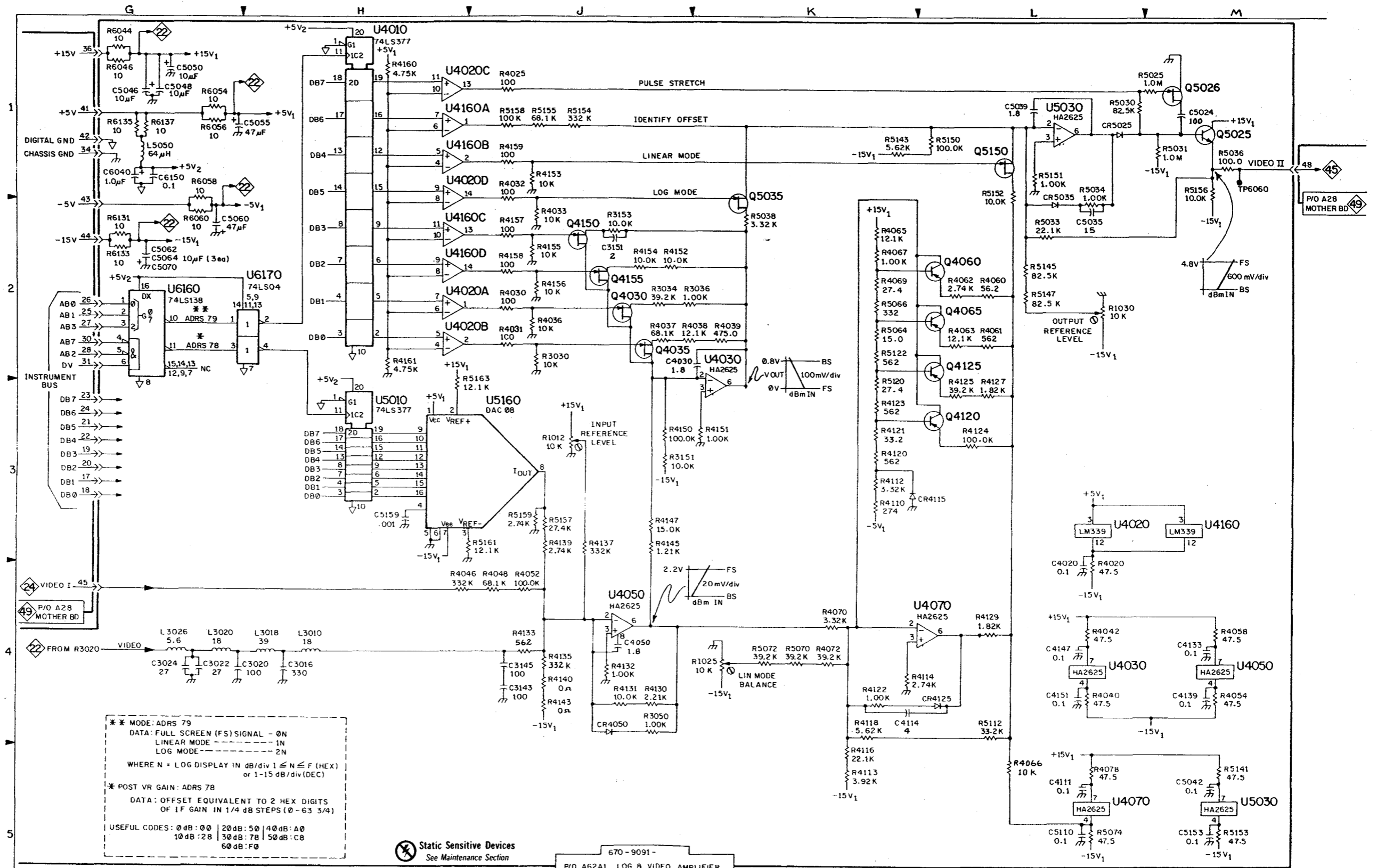

494A/494AP

670-9091-1
P/O A62A1 LOG & VIDEO AMPLIFIER 5561-523

VIDEO AMPLIFIER 23

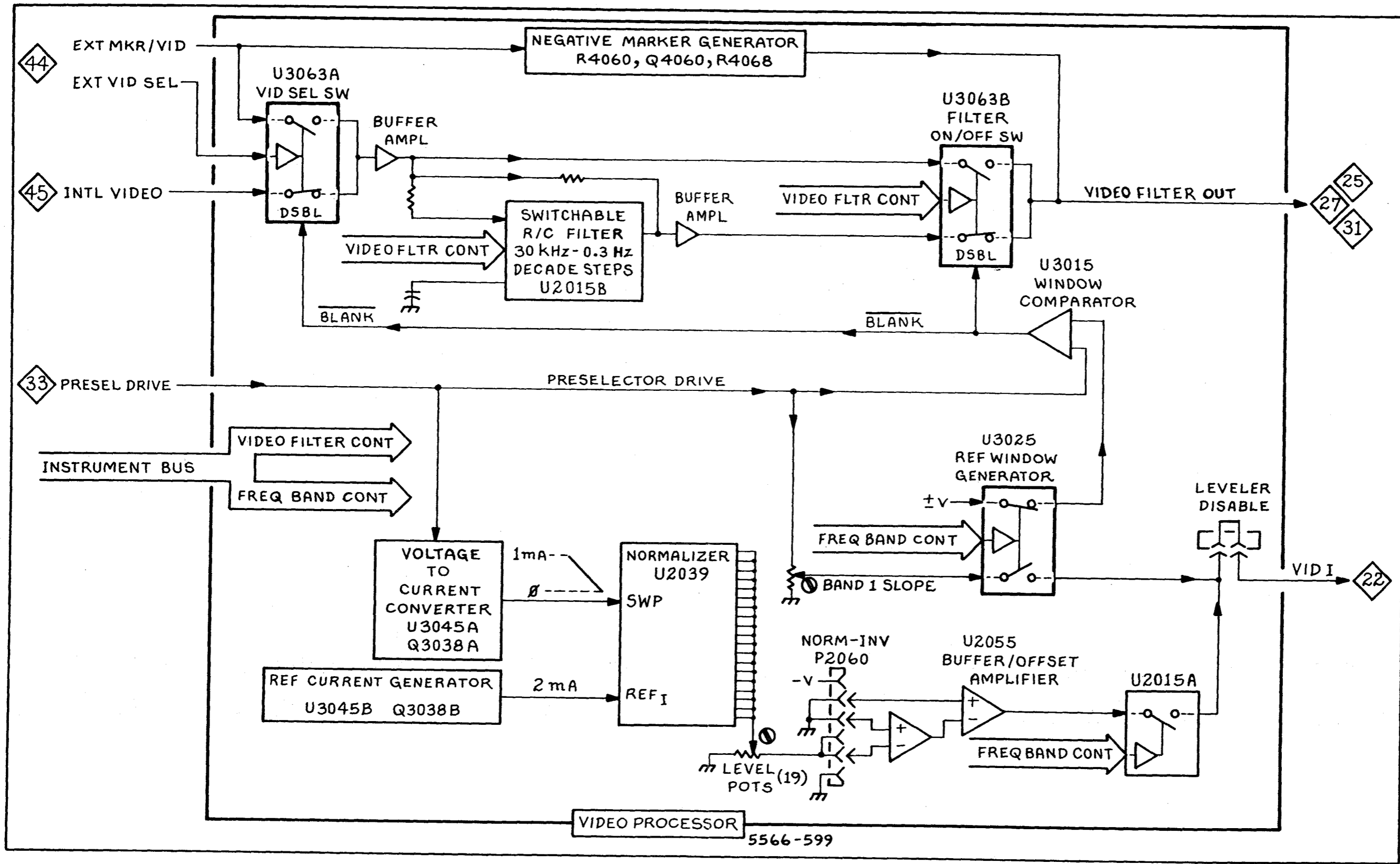

VIDEO PROCESSOR



ASSEMBLY A40

CIRCUIT NUMBER	SCHEM LOCATION	BOARD LOCATION	CIRCUIT NUMBER	SCHEM LOCATION	BOARD LOCATION	CIRCUIT NUMBER	SCHEM LOCATION	BOARD LOCATION
C2016	C2	A2	R1038	B4	D1	R4027	C3	B4
C2051	C2	D2	R1043	B4	D1	R4028	C3	B4
C2057	E4	E2	R1045	B4	D1	R4029	C2	B4
C2061	E4	F2	R1047	B3	D1	R4046	E2	D3
C2066	D4	E3	R1051	B3	E1	R4060	A1	E4
C2068	E4	F2	R1053	B3	E1	R4065	A1	E3
C3011	A4	A3	R1057	B3	E2	R4066	A1	F4
C3015	E2	A3	R1059	B3	E2	R4067	E1	F4
C3026	D2	B2	R1061	B3	F1	R4068	E1	F4
C3034	C4	D2	R1063	C4	E2			
C3035	A3	C3	R1067	A2	F2	TP2052	B4	C3
C3037	A3	D3	R1069	A2	F1	TP2063	D4	F2
C3042	A2	D3	R1070	D2	F1	TP3011	D2	B3
C3045	E4	D2	R2021	C1	B2	TP3053	E3	E2
C3048	A4	E3	R2022	C1	B2	TP3067	A1	E4
C3052	A4	E3	R2023	C1	B2	TP3069	A1	F4
C3056	D4	E2	R2051	B2	C2	TP4018	E2	A4
C3058	E4	E3	R2053	C2	E2	TP4021	B4	B4
C3059	D4	E3	R2054	E4	E2	TP4055	A2	E4
C3062	D4	E2	R2055	E4	E2	TP4065	A1	E3
C4011	B4	A4	R2056	E4	E2	TP4067	E1	F4
C4014	E2	A4	R2057	E3	E2			
			R2058	D4	F2	U2015A	E3	A2
CR2051	B2	C2	R2064	D4	E3	U2015B	D1	A2
CR3045	B2	D3	R2066	A2	F2	U2039	C2	C2
CR4016	D2	A4	R3011	E2	B3	U2055A	E3	F2
CR4060	E1	F4	R3012	E3	A3	U2055B	C4	F2
			R3020	E2	A3	U2055	E4	F2
L4042	A1	D4	R3023	A4	A3	U2055	E4	F2
L4052	A4	E4	R3024	E2	B3	U2066	D1	E3
L4053	A4	D4	R3025	D3	B3	U2066	D4	E3
			R3028	D3	B3	U3015	E2	A4
P2060	C3	E2	R3030	C2	C2	U3025	D2	B3
P3035	E2	C2	R3046	A2	E3	U3035	B3	C3
			R3053	D4	E2	U3040	A3	C3
Q3038	B2	C3	R3058	D4	F3	U3045A	B2	D2
Q4025	D3	B4	R3059	D4	F2	U3045B	B2	D2
Q4060	E1	E3	R3064	A1	F4	U3045	E4	D2
			R3065	B1	F2	U3062	C1	F2
R1012	C3	A1	R4010	C2	A4	U3062	D4	F2
R1013	C2	A1	R4011	D2	A4	U3063A	B1	F3
R1015	C3	A1	R4012	D2	A4	U3063B	E1	F3
R1019	C3	B1	R4013	D2	A4			
R1022	C3	B1	R4014	D2	A4	VR3011	A4	A3
R1024	C3	B1	R4015	D3	A3	VR4011	B4	B4
R1026	C3	B1	R4017	E3	A3	VR4028	D3	B4
R1028	C3	C1	R4018	E3	B4			
R1032	C4	C1	R4022	B4	A4	W3026	E3	B3
R1034	C4	C1	R4023	C2	A4			
R1036	C4	C1	R4025	D3	B4			

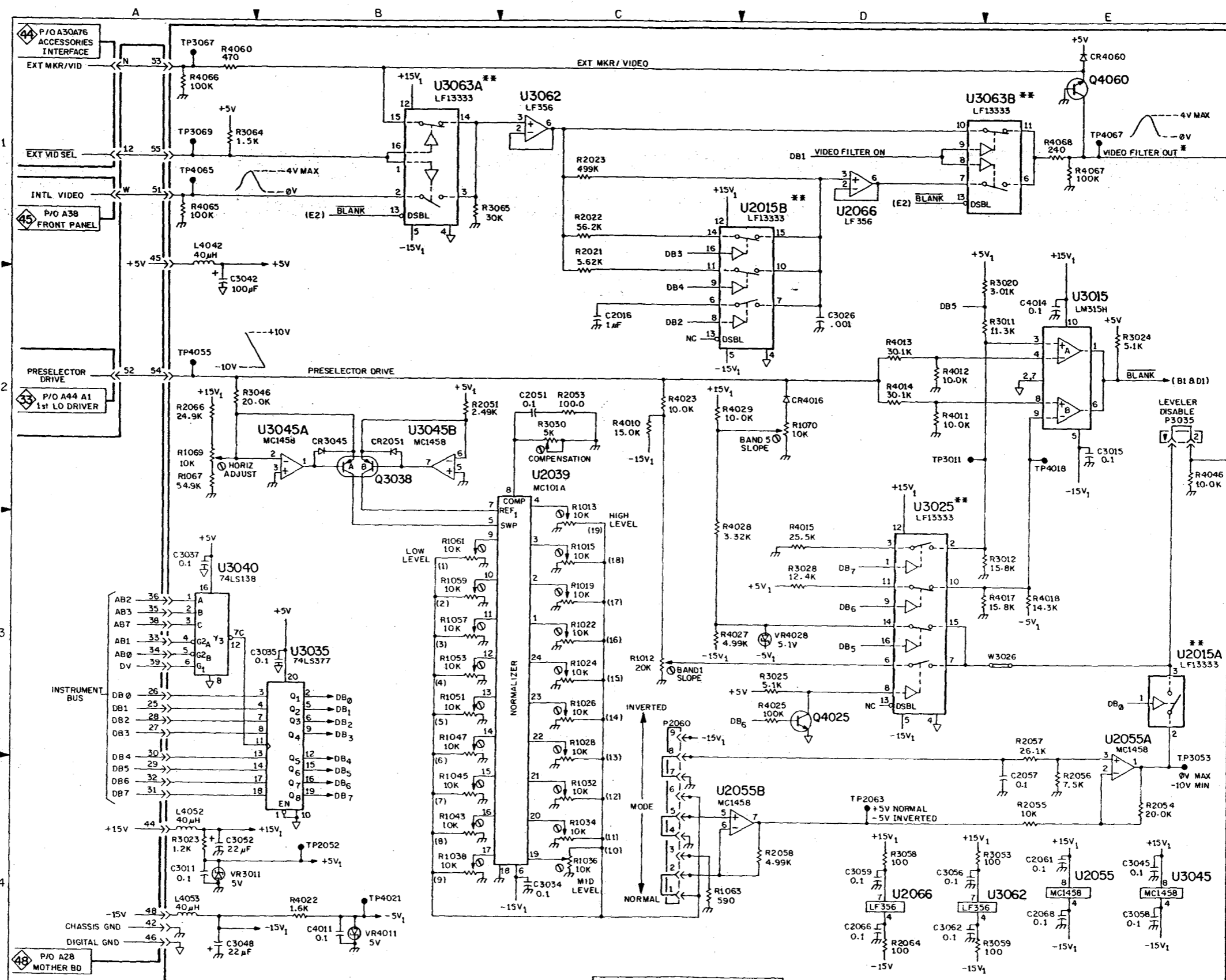

NOTE:
 * ISOLATION BETWEEN EXT MKR/VID AND INTL VIDEO INPUTS AT VIDEO FILTER OUT IS APPROXIMATELY 30dB AT 500KHz.
 ** LF13333 ARE SHOWN IN A DE-ENERGIZED STATE.

VIDEO BLANKING				LEVELING			
BAND NO.	5	6	7	BAND NO.	DB	DB	DB
1	1	1	0	1	1	1	1
2	1	1	1	2	0	1	0
3	1	1	0	3	0	1	0
4	1	1	0	4	1	1	0
5	0	1	0	5	0	1	0
6	1	1	0	6	0	1	0
7	1	1	0	7	0	1	0
8	1	1	0	8	0	1	0

VIDEO FILTER				
DB	1	2	3	4
0	0	0	0	OFF
1	0	0	0	ON
1	0	0	1	ON
1	0	1	1	ON
1	1	0	0	ON
1	1	0	1	ON
1	1	1	1	ON

ADDRESS				
A8	A1	A2	A3	DV
0	0	1	1	0

Static Sensitive Devices
 See Maintenance Section

494A/494AP

A40 VIDEO PROCESSOR 670-8389-01 5541-524

VIDEO PROCESSOR

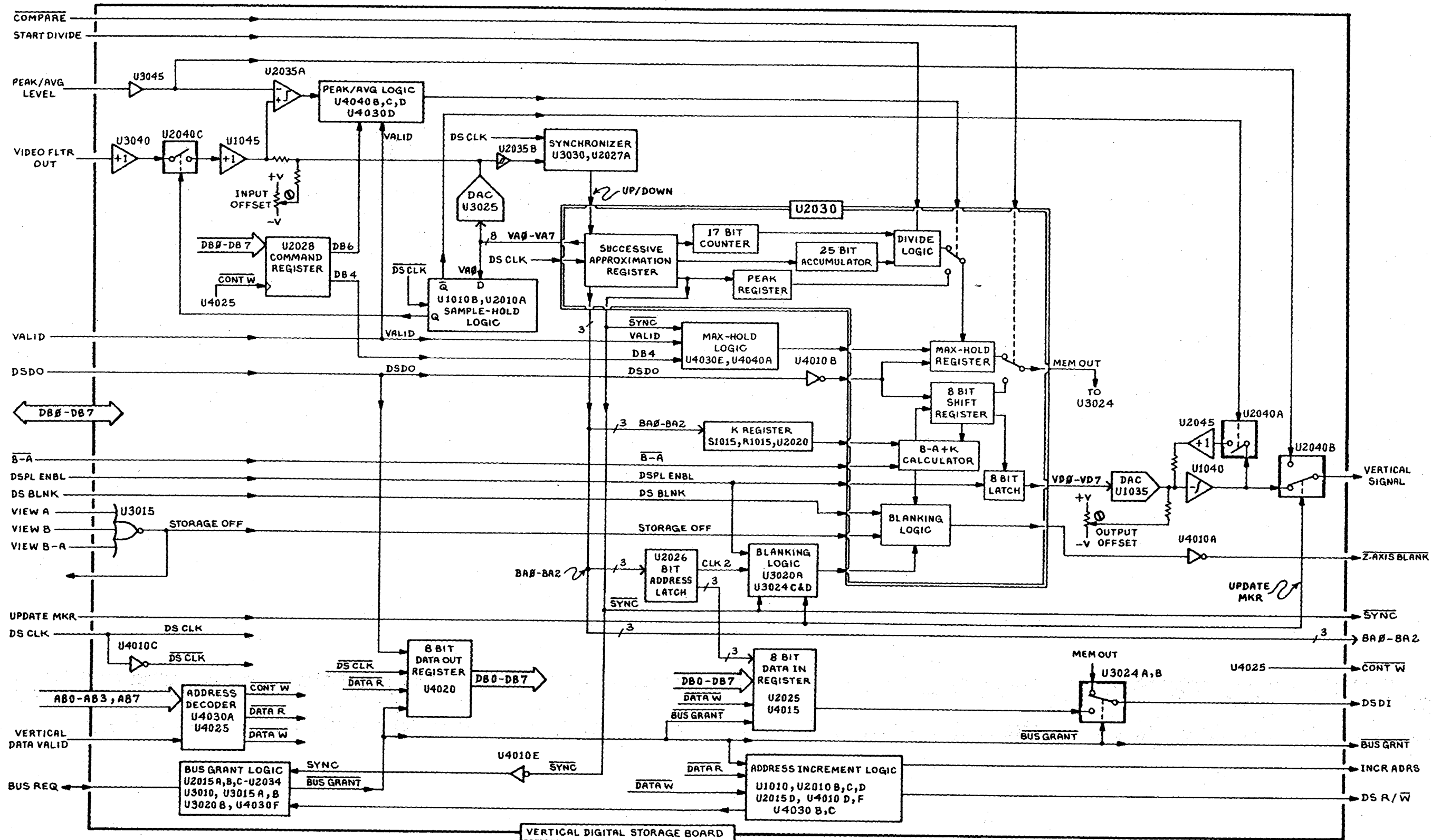

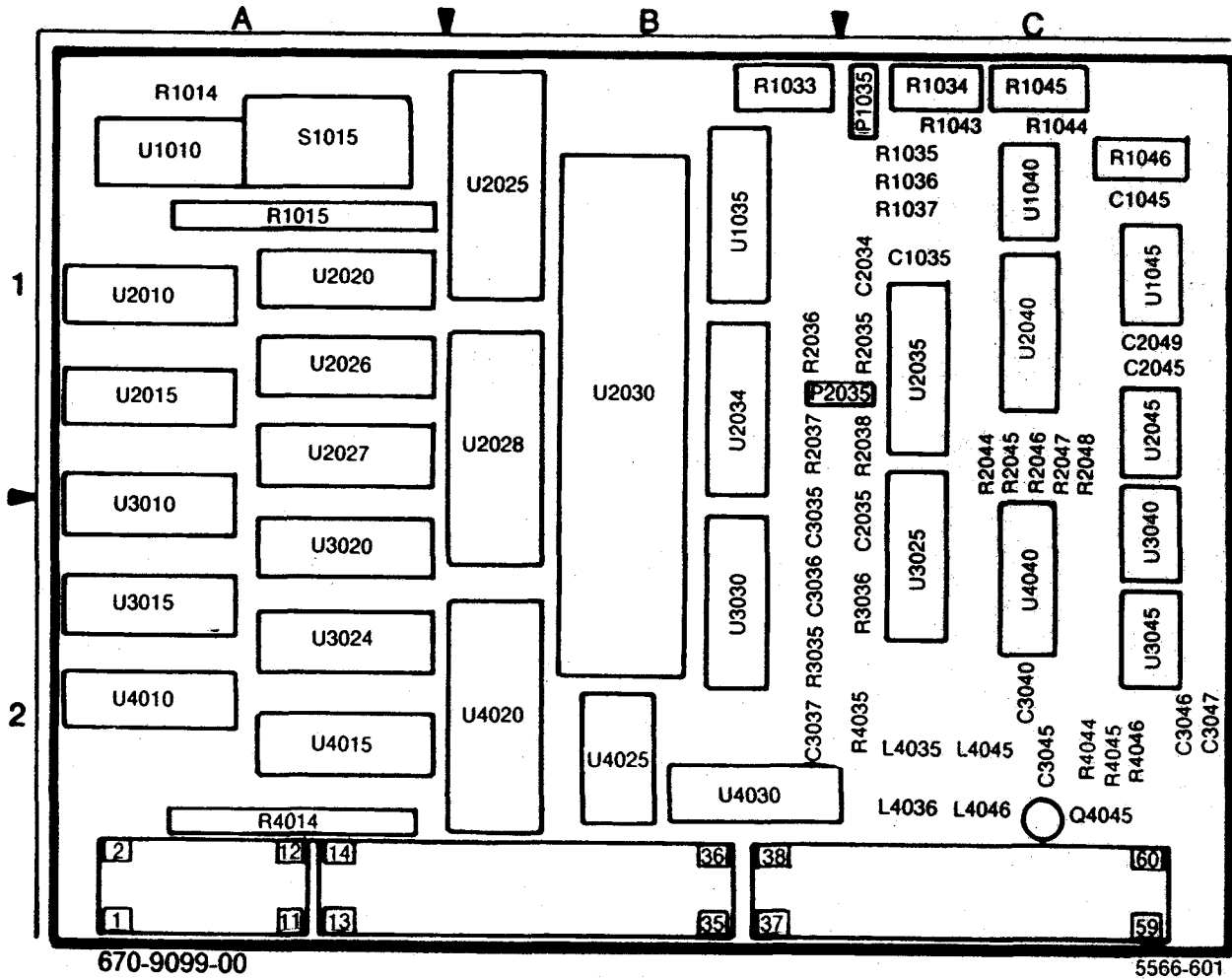
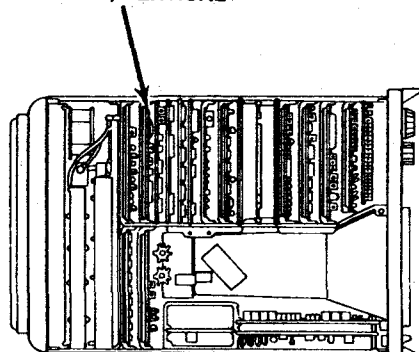

Fig. 10-37. A61A1—Vertical Digital Storage circuit board.

DIGITAL STORAGE, VERTICAL



VERTICAL DIGITAL STORAGE



ASSEMBLY A61A1

CIRCUIT NUMBER	SCHEM LOCATION	BOARD LOCATION	CIRCUIT NUMBER	SCHEM LOCATION	BOARD LOCATION	CIRCUIT NUMBER	SCHEM LOCATION	BOARD LOCATION
C1035	F1	C1	R4045	B4	C2	U3015B	A2	A2
C1045	B4	C1	R4046	B4	C2	U3015A	E3	A2
C2034	E1	C1				U3015C	E3	A2
C2035	D2	C2	S1015	A1	A1	U3020A	B2	A2
C2045	F2	C1						
C2049	F1	C1	U1010A	E3	A1	U3020B	E4	A2
C3035	E4	B2	U1010B	D3	A1	U3020	B3	A2
C3036	B1	B2						
C3037	F4	B2				U3024A	F2	A2
C3040	F4	C2				U3024B	F2	A2
C3045	F4	C2	U1035	E1	B1	U3024C	B2	A2
C3046	F4	C2	U1040	F1	C1	U3024D	B2	A2
C3047	B4	C2	U1045	B4	C1			
			U2010A	D2	A1	U3025	D2	C2
L4035	F4	C2	U2010B	F3	A1	U3030	B1	B2
L4036	F4	C2	U2010C	F3	A1	U3040	A4	C2
L4045	F4	C2	U2010D	E4	A1	U3045	B4	C2
L4046	F4	C2	U2015A	E3	A1			
			U2015B	E3	A1	U4010A	F1	A2
P1035	E1	C1	U2015C	D4	A1			
P2035	C2	C1	U2015D	F3	A1	U4010B	B1	A2
			U2020	B1	A1	U4010C	B2	A2
Q4045	B2	C2						
Q4045	D4	C2						
			U2025	E2	B1	U4010D	E3	A2
R1014	F4	A1				U4010E	D3	A2
R1015	A1	A1				U4010F	E4	A2
R1033	E1	B1	U2026	E2	A1			
R1034	C2	C1	U2027A	C1	A1	U4015	E2	A2
R1035	E1	C1	U2027B	D4	A1			
R1036	F1	C1	U2028	B3	B1			
R1037	E1	C1				U4020	F2	B2
R1043	E1	C1				U4025	A2	B2
R1044	A3	C1	U2030	D1	B1			
R1045	E1	C1						
R1046	C4	C1						
R2035	C3	B1	U2034	D3	B1			
R2036	C4	B1	U2035A	B4	C1	U4030A	A3	B2
R2037	F4	B1	U2035B	C3	C1			
R2038	F4	C1				U4030B	F3	B2
R2044	C2	C1	U2040A	F1	C1	U4030C	F3	B2
R2045	C3	C1				U4030D	C2	B2
R2046	C4	C1				U4030E	C3	B2
R2047	B4	C1	U2040B	F1	C1	U4030F	E3	B2
R2048	C4	C1	U2040C	B4	C1	U4040A	C2	C2
R3035	D4	B2	U2045	F1	C1	U4040D	C1	C2
R3036	B1	C2	U3010A	E3	A2	U4040B	C2	C2
R4014	A1	A2	U3010B	E3	A2	U4040C	C2	C2
R4035	B2	C2	U3010C	E3	A2			
R4044	B4	C2	U3010D	E4	A2			

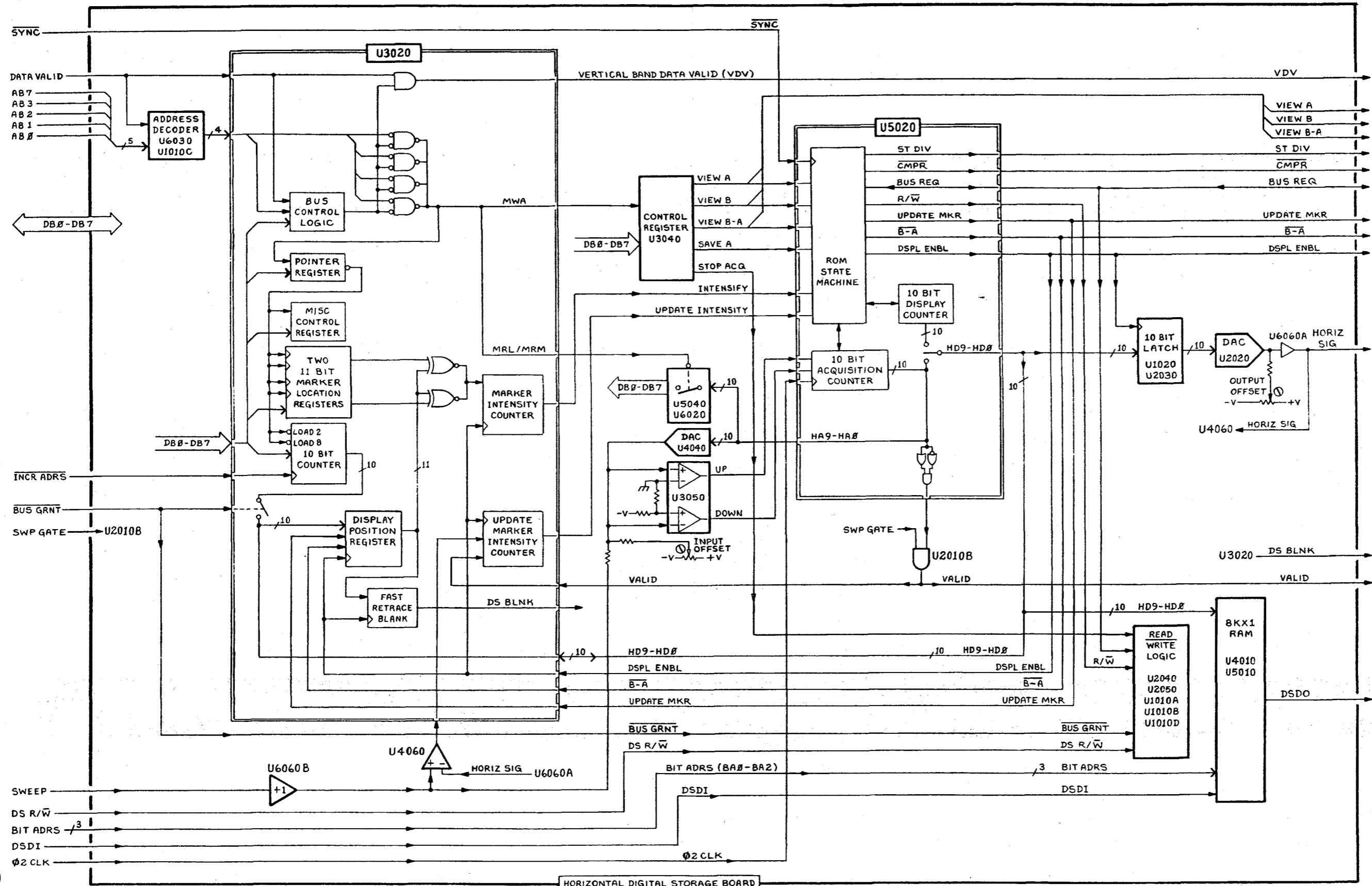

HORIZONTAL DIGITAL STORAGE BOARD 5566-605

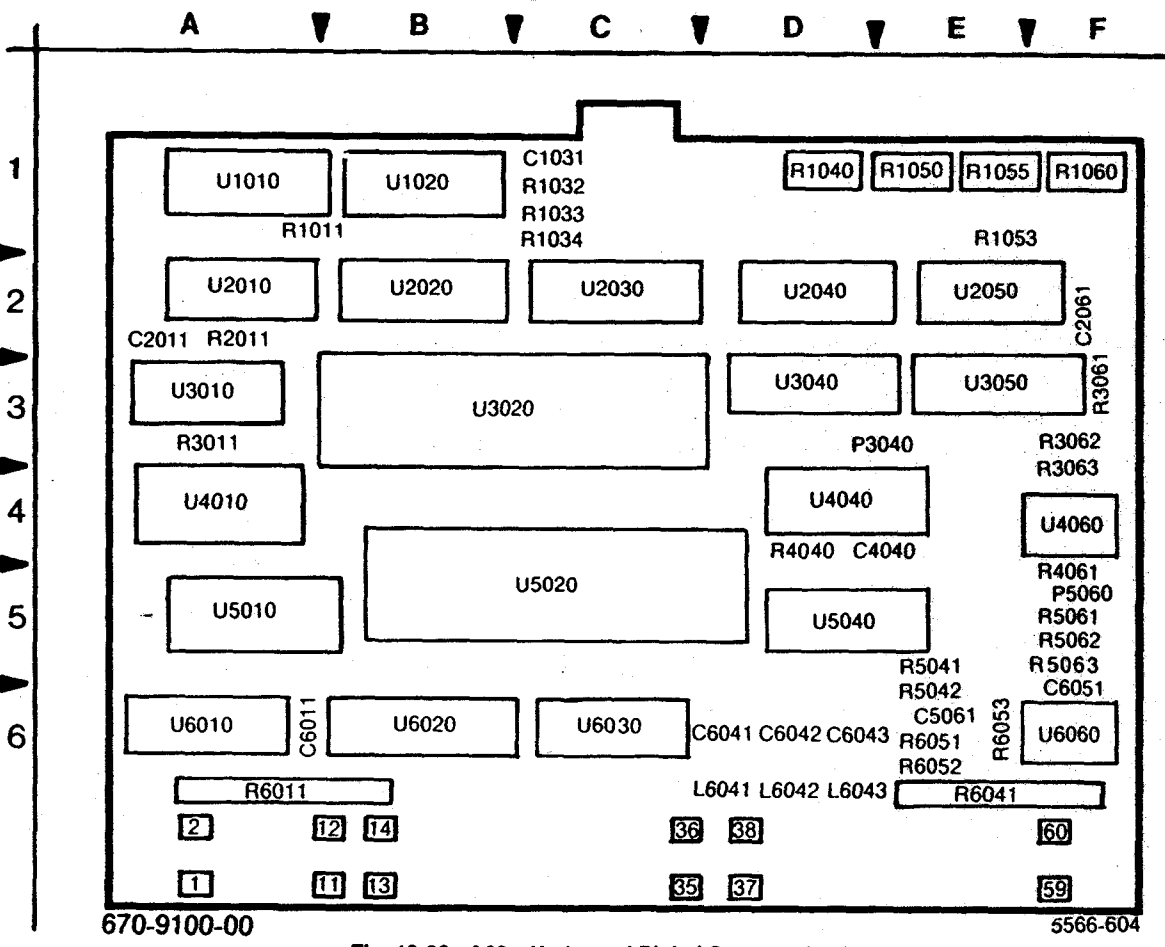
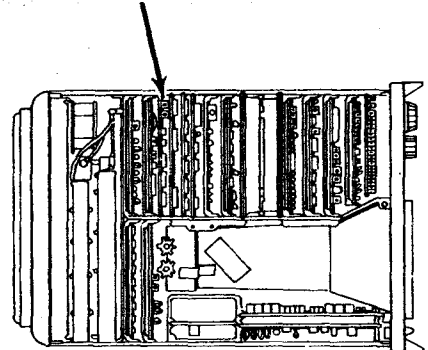

Fig. 10-38. A60—Horizontal Digital Storage circuit board.

DIGITAL STORAGE, HORIZONTAL



HORIZONTAL DIGITAL STORAGE



ASSEMBLY A60

CIRCUIT NUMBER	SCHEM LOCATION	BOARD LOCATION	CIRCUIT NUMBER	SCHEM LOCATION	BOARD LOCATION	CIRCUIT NUMBER	SCHEM LOCATION	BOARD LOCATION
C1031	B4	C1	R6011B	A2	A6			
C2011	E4	A2	R6011C	A3	A6	U2040	C4	D2
C2061	A2	F2	R6011D	A3	A6			
C4040	B3	E4	R6011E	A3	A6	U2050	B4	E2
C5061	F5	E6	R6011F	A3	A6			
C6011	A5	A6	R6011G	A3	A6	U3010A	D1	A3
C6041	A4	D6	R6041A	C5	E6	U3010B	E4	A3
C6042	A5	D6	R6041B	A4	E6	U3020	D1	B3
C6043	A5	D6	R6041C	A4	E6			
C6051	A2	F5	R6041D	A4	E6			
			R6041E	A2	E6			
L6041	A4	D6	R6041F	A4	E6			
L6042	A4	D6	R6051	A2	E6			
L6043	A5	D6	R6052	B2	E6	U3040	B1	D3
			R6053	A2	E6			
P3040	B3	E3				U3050	B2	E3
P5060	E5	F5	U1010A	C4	A1			
			U1010C	A5	A1			
R1011	C2	A1	U1010E	C4	A1	U4010	F3	A4
R1032	B4	C1	U1010D	E4	A1	U4040	B3	D4
R1033	E5	C1	U1010F	C1	A1			
R1034	E5	C1						
R1040	F5	D1	U1010B	B4	A1	U4060	D3	F4
R1050	E5	E1						
R1053	B3	E1						
R1055	A1	E1						
R1060	A3	F1						
R2011	E4	A2	U1020	E4	B1	U5010	F1	A5
R3011	F3	A3	U2010A	C2	A2	U5020	B1	C5
R3061	B2	F3	U2010C	E3	A2			
R3062	B2	F3	U2010B	D1	A2	U5040	E1	D5
R3063	A2	F3						
R4040	B3	D4						
R4061	D3	F4				U6010	E3	A6
R5041	B2	E5				U6020	E2	B4
R5042	B2	E6				U6030	A5	C6
R5061	E5	F5	U2030	E5	C2	U6060A	F5	F6
R5062	E5	F5				U6060B	A2	F6
R5063	F5	F5						
R6011A	C4	A6						

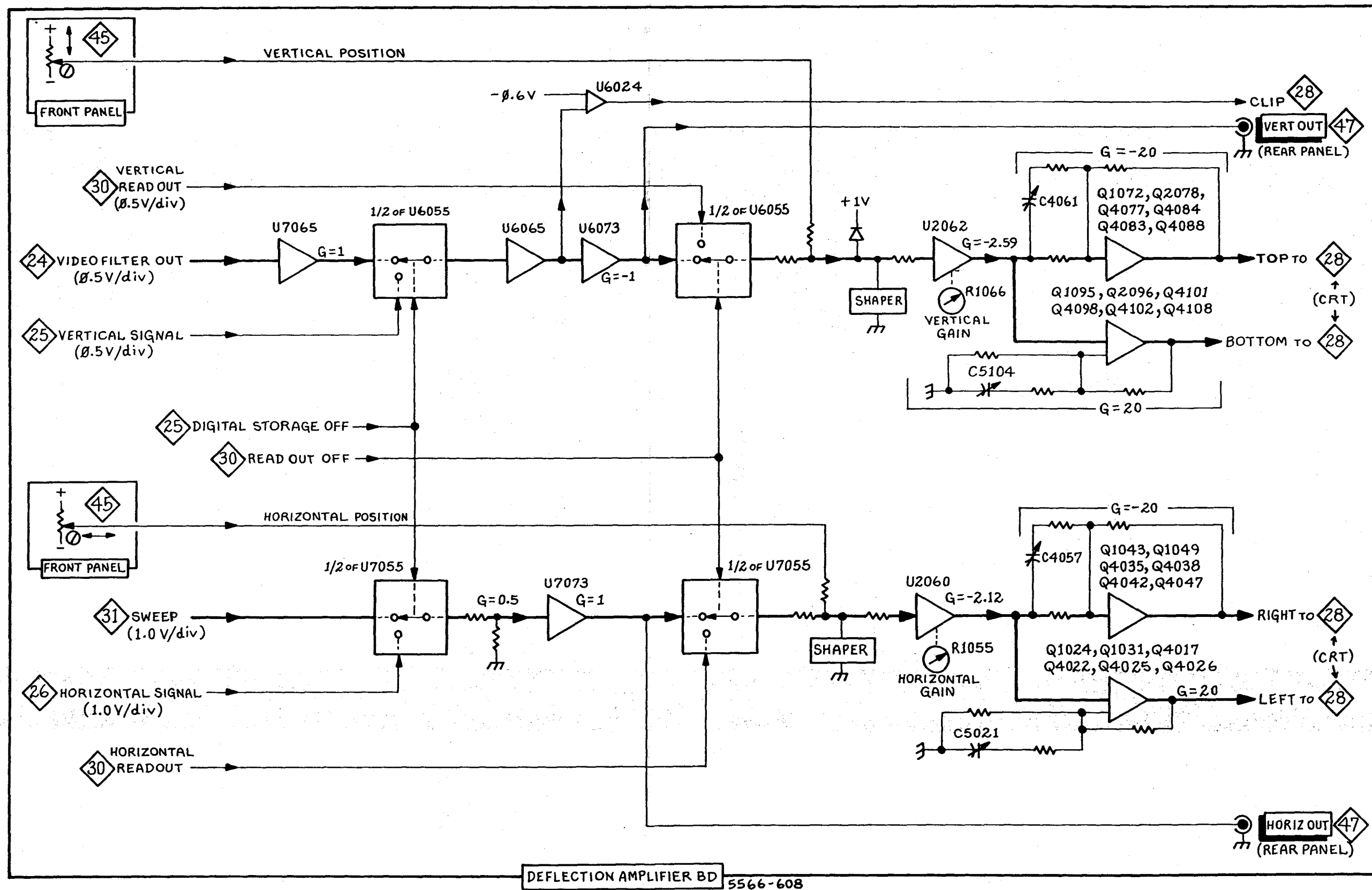

DEFLECTION AMPLIFIERS



ASSEMBLY A64A1

CIRCUIT NUMBER	SCHEM LOCATION	BOARD LOCATION	CIRCUIT NUMBER	SCHEM LOCATION	BOARD LOCATION	CIRCUIT NUMBER	SCHEM LOCATION	BOARD LOCATION	CIRCUIT NUMBER	SCHEM LOCATION	BOARD LOCATION
C1018	E3	A1	P3033	E3	C2	R2076	E2	G1	R5083	C2	H5
C1023	E3	B1	P3078	E1	G3	R2109	D2	K2	R5084	D1	H5
C1049	E3	D1	P4092	E2	J2	R3023	D4	B3	R5086	D2	H5
C2022	E3	B2				R3027	D4	B2	R5096	D2	J5
C2037	E3	C2	Q1024	E3	B1	R3031	D3	C3	R5097	D2	J5
C2047	C3	D2	Q1031	E3	B1	R3035	D3	C3	R5099	D2	J5
C2055	C3	E2	Q1043	E3	D1	R3037	D3	C3	R5102	D2	K5
C2066	C1	F2	Q1049	E3	D1	R3045	D3	D3	R6017	C4	A6
C2073	E2	G1	Q1072	E1	G1	R3069	C1	F3	R6032	A3	C6
C2078	D1	G1	Q1095	E2	J1	R3084	D1	G3	R6034	A2	C6
C2083	E1	G1	Q2078	E1	G1	R3086	D1	H3	R6071	B1	G6
C2087	E1	H2	Q2096	E2	J2	R3088	D1	H3	R6072	B1	G6
C2101	E2	J2	Q4017	D4	A5	R3089	D1	H3	R6073	B1	G6
C2103	E2	K2	Q4022	D4	B4	R3091	D1	J3	R6081	B1	H6
C2106	D2	K2	Q4025	D4	B4	R3098	D2	J3	R6082	C1	H5
C3021	C4	B3	Q4026	E3	C4	R3107	D2	K3	R6084	B3	H6
C3039	E3	C3	Q4035	E3	C4	R3117	D2	L3	R6086	A2	H6
C3051	E3	C3	Q4038	D3	C4	R4016	D4	A4	R6109	C2	L6
C4057	C3	E3	Q4042	E3	D4	R4019	D4	A4	R7021	C1	B7
C4061	C1	F3	Q4047	D3	D4	R4021	D4	B4	R7022	B2	B7
C5021	D4	A2	Q4077	D1	G4	R4033	D3	C4	R7023	B2	B7
C5033	D3	C5	Q4078	C2	G4	R4048	C3	D4	R7031	A2	C7
C5058	B4	E5	Q4083	D1	G3	R4049	C3	D4	R7032	B1	C7
C5089	D1	J5	Q4084	E2	H4	R4051	B3	E4	R7034	B1	C7
C5104	D2	K4	Q4088	E1	H4	R4052	C3	E4	R7051	A3	F7
C6033	B2	C6	Q4098	E2	J4	R4059	C3	E4	R7078	A4	H7
C6037	A2	C6	Q4101	D2	K5	R4061	C3	E4	R7079	A4	H7
C6073	B1	G6	Q4102	D2	K6	R4062	C1	F4	R7081	A3	G7
C6081	B1	H6	Q4108	D2	K6	R4064	C1	F4	R8071	A1	G8
C7015	B1	A7				R4065	C1	F5			
C7061	A3	F7	R1022	E3	B1	R4067	C1	F5	TP1016	A4	A2
C7071	A3	G7	R1023	E3	B1	R4069	C1	F5			
C7073	A4	G7	R1024	E3	B1	R4071	D1	G4	U2060	B4	E2
C7074	A4	G7	R1031	E3	C1	R4072	C2	G4	U2062	B4	F2
C7088	A4	H7	R1034	E3	C1	R4078	D1	H4	U2062	C1	F2
C7093	A4	J7	R1044	E3	D1	R4101	D2	J4	U6024	B1	B6
			R1045	E3	D1	R4103	D2	K4	U6024	B4	B6
CR4051	C3	E4	R1049	E3	D1	R5023	D4	B5	U6055A	A1	D6
CR4052	C3	E4	R1052	D3	D1	R5025	D4	B5	U6055B	C1	D6
CR4056	C3	E4	R1055	C3	E1	R5027	D4	B5	U6065	B1	F5
CR4058	C3	E4	R1066	C2	F1	R5029	D3	B5	U6065	B4	F5
CR4063	C1	F4	R1081	E1	H1	R5035	D3	C5	U6073	B1	G5
CR4064	C1	F4	R1082	E1	H1	R5037	D3	C5	U6073	B4	G5
CR5054	B1	D4	R1084	E1	H1	R5039	D3	C5	U7055A	A3	D7
CR5055	B1	E5	R1085	E1	H1	R5041	D3	D4	U7055B	B3	D7
			R1087	E2	H1	R5042	D3	D4	U7065	A1	F6
L7061	A3	F7	R1102	E2	K1	R5049	B1	D4	U7065	B4	F6
L7069	A3	F7	R1103	E2	K1	R5053	B1	E5	U7073	A3	G6
L7081	A4	H7	R1104	E2	K1	R5057	C3	D4	U7073	B4	G6
L7088	A4	J7	R2025	D4	B2	R5058	C3	E5	U7073	E1	G6
			R2057	C3	E2	R5059	C3	E5			
P1016	E3	A1	R2059	C3	E2	R5062	C3	F5	VR1035	E3	C1
P1035	E4	C1	R2062	C2	F2	R5081	D1	H5	VR3074	E2	G3
P2100	E2	L2	R2066	C1	F2	R5082	D1	H5			

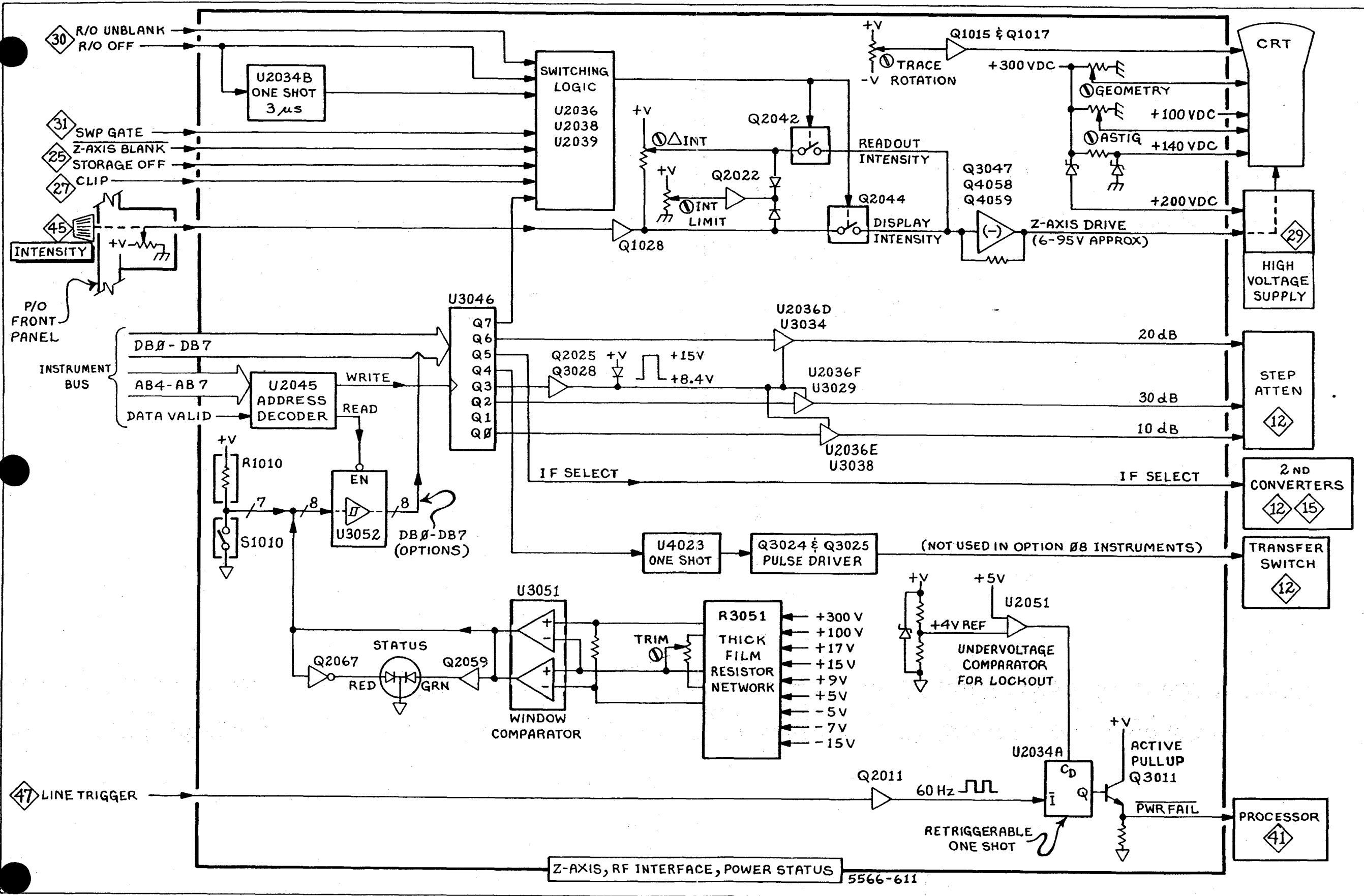

Z-AXIS, RF INTERFACE, POWER STATUS

28

ASSEMBLY A70

CIRCUIT NUMBER	SCHEM LOCATION	BOARD LOCATION	CIRCUIT NUMBER	SCHEM LOCATION	BOARD LOCATION	CIRCUIT NUMBER	SCHEM LOCATION	BOARD LOCATION	CIRCUIT NUMBER	SCHEM LOCATION	BOARD LOCATION
C1026	B2	B1	CR4013	D2	A4	R1051	E1	E1	R4014	C3	A4
C1063	D1	F1				R1052	E1	E1	R4016	C5	A4
C1064	D1	F1	DS1062	B4	F1	R1054	D1	E1	R4024	B3	B4
C2024	A1	B2				R1055	D2	E1	R4058	E2	E4
C2031	A1	C2	M1019	E1	A1	R1056	D4	E2			
C2035	B1	C2				R1058	E1	E1	S1010	A4	A1
C2038	E4	C2	P1011	E5	A1	R1064	E1	F1			
C2041	C1	D2	P1015	E1	B1	R1065	C5	F1	TP1011	C1	A1
C2045	A2	D3	P1040	E5	D1	R1066	E1	F1	TP1034	C1	C1
C2051	E4	E2	P1056	E1	E1	R1067	D1	F1	TP1035	C1	C1
C2052	C5	E2	P2016	E5	B2	R1068	D1	F1	TP1036	D1	C1
C2053	D2	F2				R2022	B3	B2	TP1037	D1	C1
C2054	C5	E2	Q1015	E1	A1	R2024	A1	B2	TP1044	D1	D1
C2055	E4	E2	Q1017	E1	A1	R2025	A1	B2	TP1046	D1	D1
C2058	C4	E3	Q1028	A2	B1	R2026	B2	B2	TP1047	D1	D1
C3026	C3	B2	Q1028	C2	B1	R2027	C2	B2	TP1048	D1	D1
C3029	D2	B2	Q2011	D5	A2	R2028	B3	B2	TP1052	D1	E1
C3031	A1	C3	Q2022	C1	B1	R2050	D4	E2	TP1068	C3	F1
C3038	C2	C3	Q2025	B2	B2	R2051	B4	E2	TP1069	D4	F1
C3039	C3	C3	Q2042	D1	D2	R2052	E4	E2			
C3041	C4	D3	Q2044	D2	D2	R2053	D4	E2	U2034A	E4	C1
C3051	C4	D3	Q2059	B4	F2	R2054	C4	E2	U2034B	A1	C1
C3053	D2	F2	Q2067	B4	F2	R2055	C4	E2	U2036A	A1	C2
C4015	B3	A4	Q3011	E4	A2	R2056	C4	E2	U2036B	C1	C2
C4016	D5	A4	Q3024	C3	B2	R2057	E2	F2	U2036D	C3	C2
C4026	B3	B4	Q3025	C3	B2	R2058	C4	E2	U2036E	C2	C2
C4046	B2	D4	Q3028	C3	B2	R2059	C4	E2	U2036F	D2	C2
C4052	A3	D4	Q3047	D1	F2	R2060	B4	F2	U2038	C1	D1
C4057	E2	E4	Q4058	E2	F3	R2063	D1	F2	U2039	B1	D2
			Q4059	E1	F3	R2064	D1	F2	U2045	A3	D2
CR1043	D2	D1				R2065	B4	F2	U2051	E4	E2
CR1045	D1	D1	R1010	A4	A1	R2066	D2	F2	U3029	D2	B2
CR2013	D5	A2	R1015	E1	A1	R3010	C3	A3	U3034	D3	C3
CR2029	D3	B2	R1020	D4	B1	R3011	E5	A2	U3038	D2	D3
CR2058	C5	F2	R1021	D1	B1	R3012	C3	A3	U3046	B2	D3
CR2059	C4	E2	R1022	C2	B1	R3013	C3	A3	U3046	E3	D3
CR3016	C2	A3	R1023	D1	B1	R3016	B3	A3	U3051	C4	E3
CR3017	D3	A3	R1024	C2	B1	R3041	A1	D3	U3052	A3	E3
CR3018	D3	A3	R1025	C1	B1	R3045	D2	E3	U4023	B3	B4
CR3022	D3	B2	R1026	C2	B1	R3050	B4	E3			
CR3023	E2	B2	R1027	C1	B1	R3051	D4	E3	VR1052	E2	E1
CR3024	E2	B2	R1028	C2	B1	R3056	C4	E3	VR2014	C3	A3
CR3051	A4	E3	R1030	C1	C1	R3059	C4	E3	VR2053	D4	E2
CR3059	E2	F3	R1044	D4	D1	R3060	B5	F3	VR2062	E2	F2
CR3060	B5	F3	R1045	C1	D1	R4010	D5	A4	VR3015	C3	A3
CR3066	E2	F3	R1046	C1	D1	R4012	C3	A4			
CR4012	D2	A4	R1050	D1	E1	R4013	C3	A4			

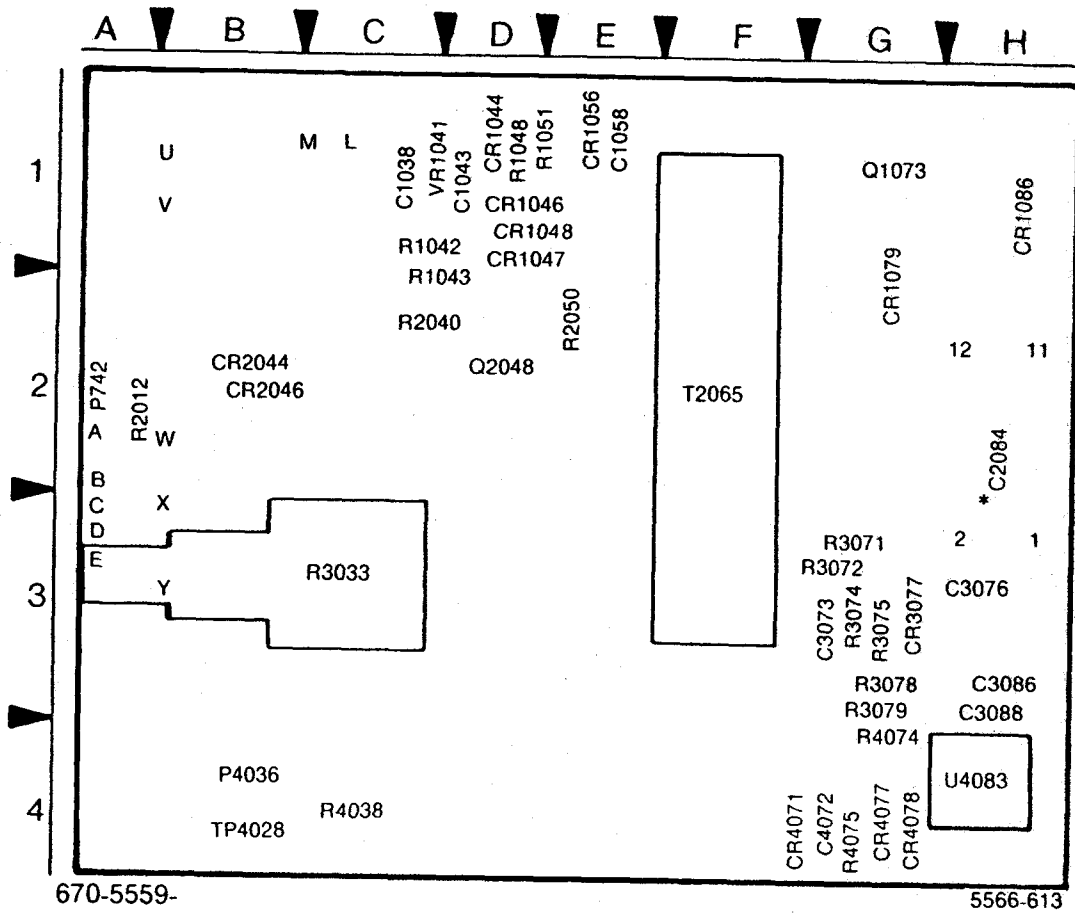
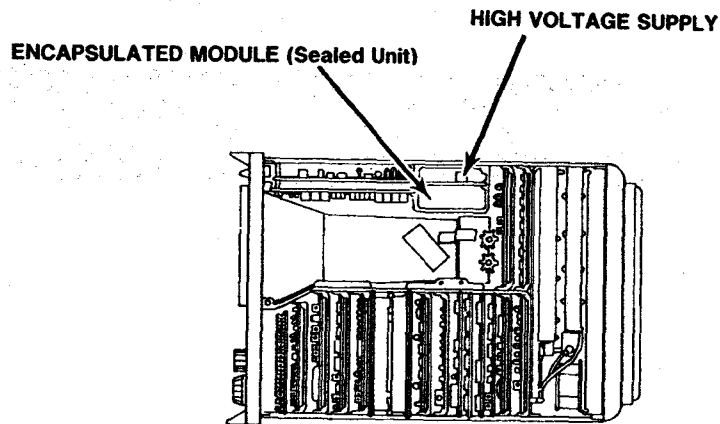

Fig. 10-41. A74—High Voltage circuit board.

* MOUNTED ON REAR OF BOARD



5566-614

HIGH VOLTAGE SUPPLY



ASSEMBLY A74

CIRCUIT NUMBER	SCHEM LOCATION	BOARD LOCATION	CIRCUIT NUMBER	SCHEM LOCATION	BOARD LOCATION
C1038	C2	C1	Q2048	B3	D2
C1043	B3	D1			
C1058	B2	E1	R1042	C2	C1
C2084	A1	H2	R1043	C3	C2
C3073	B2	G3	R1048	B2	D1
C3076	A1	H3	R1051	B3	D1
C3086	A3	H3	R2012	B1	A2
C3088	A3	H3	R2040	C3	C2
C4072	C2	G4	R2050	C3	E2
			R3033	C2	C3
CR1044	A2	D1	R3071	A1	G3
CR1046	B3	D1	R3072	A2	G3
CR1047	B3	D1	R3074	A2	G3
CR1048	B3	D1	R3075	A2	G3
CR1056	C2	E1	R3078	B2	G3
CR1079	A2	G2	R3079	C1	G3
CR1086	A1	H1	R4038	C1	C4
CR2044	E3	B2	R4074	C1	G4
CR2046	D3	B2	R4075	C2	G4
CR3077	A2	G3			
CR4071	C2	F4	T2065	B1	F2
CR4077	B2	G4			
CR4078	B2	G4	TP4028	C1	B4
P742	A2	A2	U4083	A3	H4
P4036	C1	B4	U4083	B1	H4
Q1073	A1	G1	VR1041	C3	C1

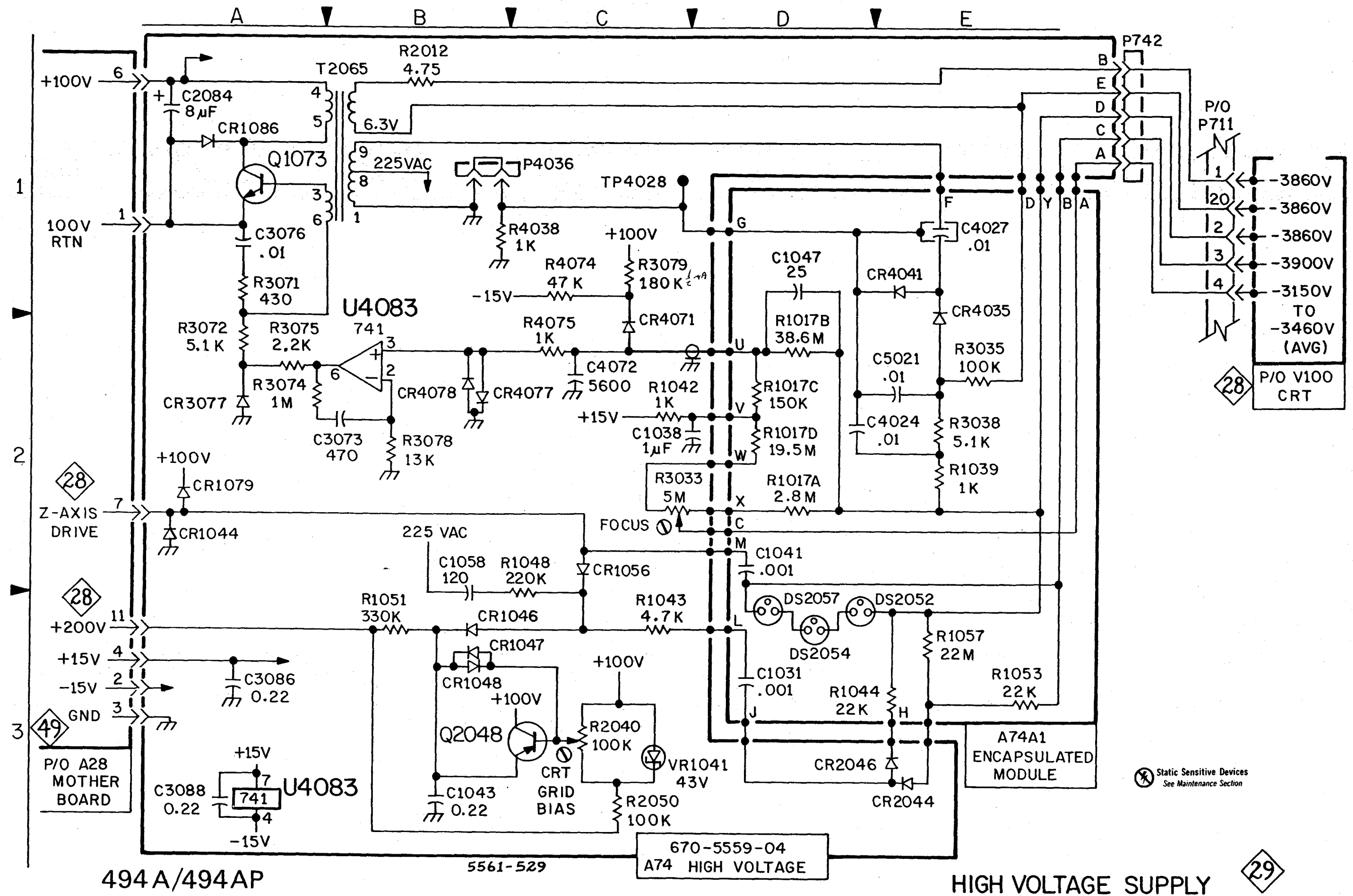

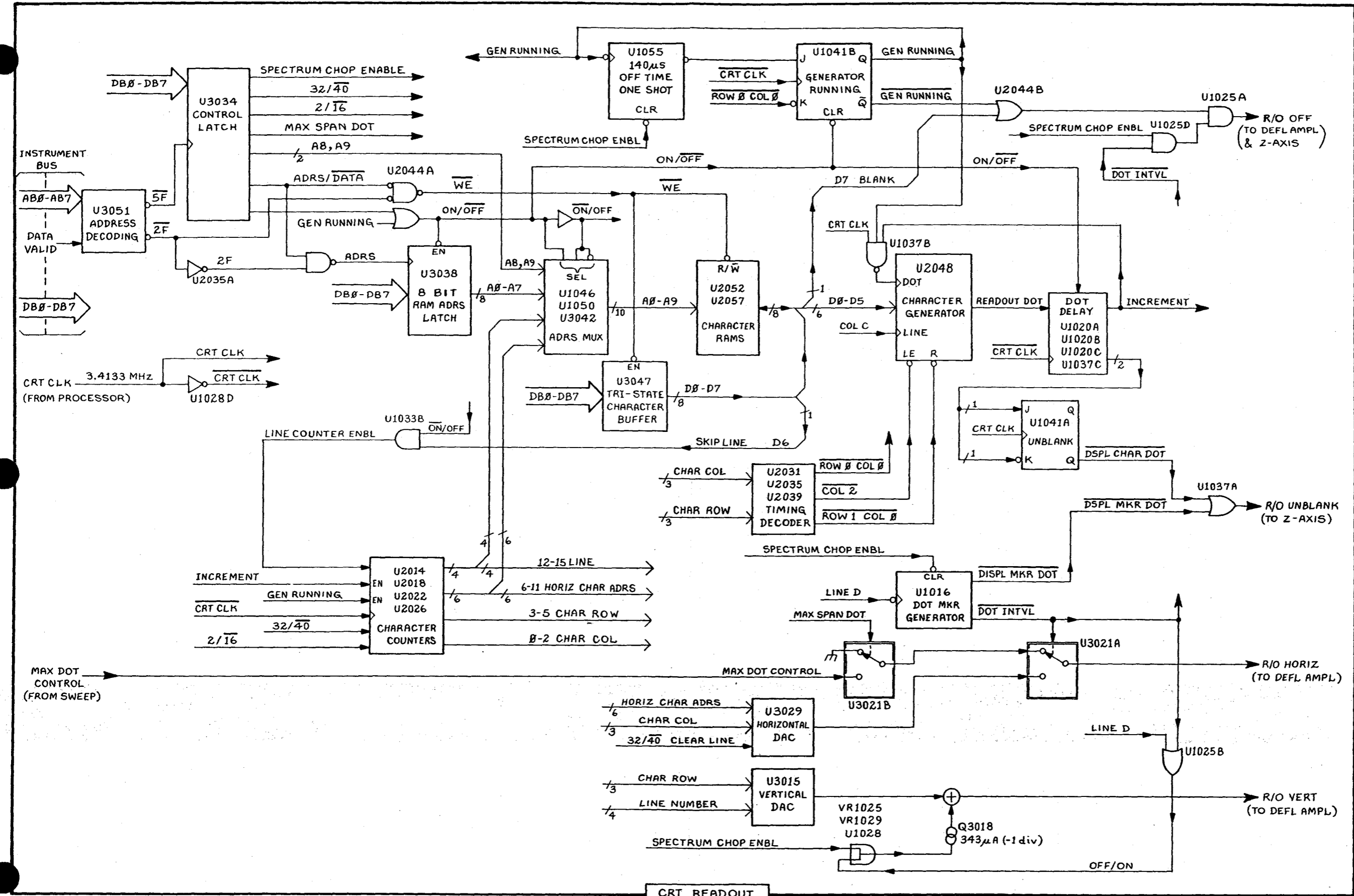

CRT READOUT 5566-616

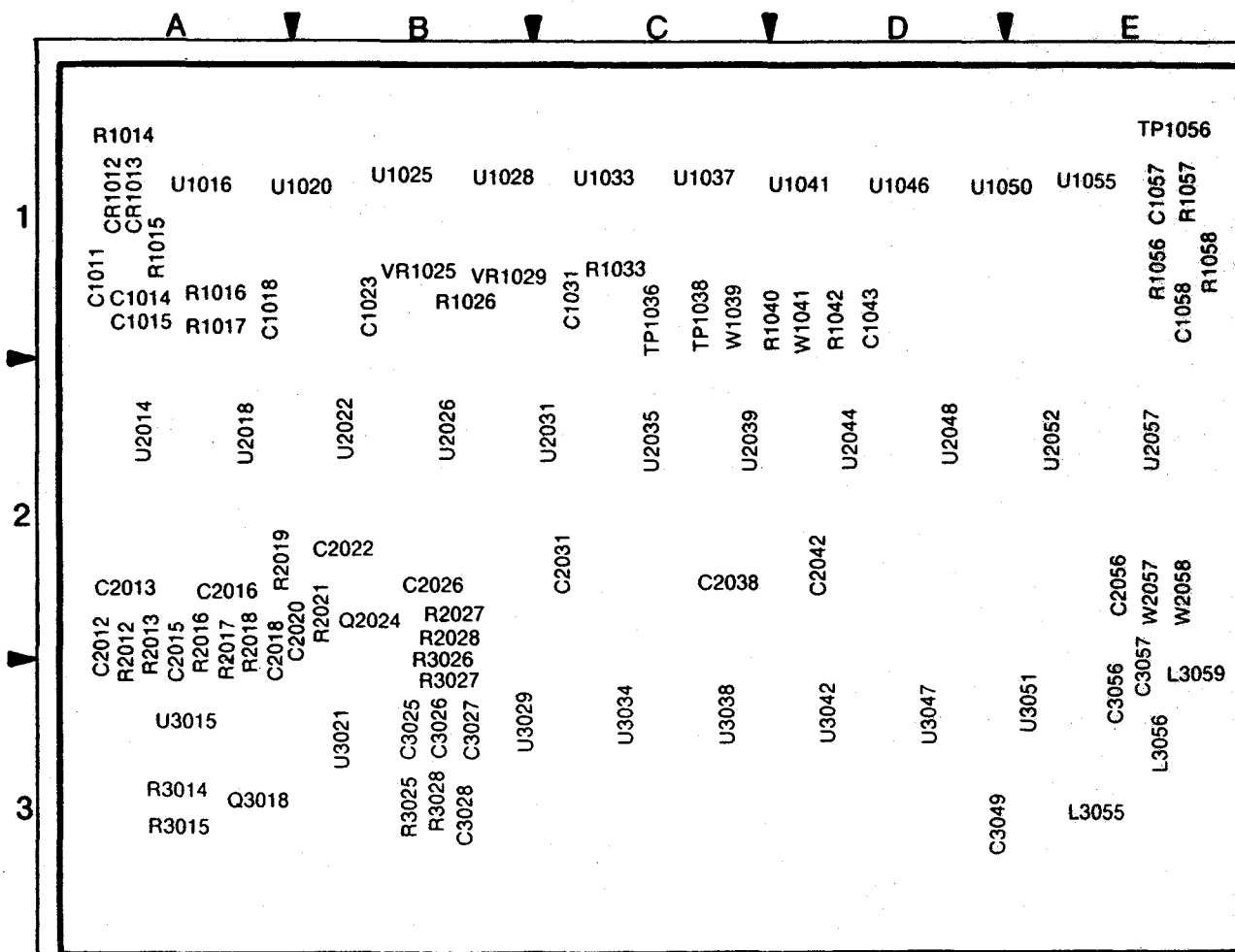

670-7902-

Fig. 10-42. A66A1—CRT Readout circuit board.

5566-615

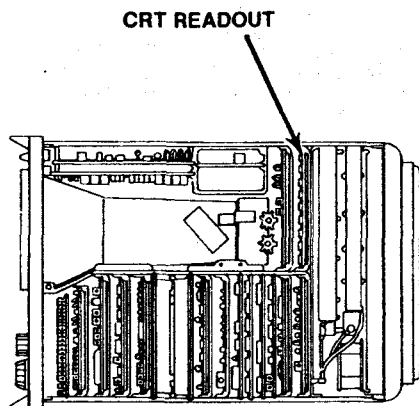

5566-617

CRT READOUT



ASSEMBLY A66A1

CIRCUIT NUMBER	SCHEM LOCATION	BOARD LOCATION	CIRCUIT NUMBER	SCHEM LOCATION	BOARD LOCATION	CIRCUIT NUMBER	SCHEM LOCATION	BOARD LOCATION
C1011	F3	A1	R1057	C1	E1	U1050	C1	D1
C1014	F2	A1	R1058	B2	E1	U1055	C1	E1
C1015	F3	A1	R2012	E4	A2	U2014	A3	A2
C1018	A2	A1	R2013	F3	A2	U2014	C4	A2
C1023	A2	B1	R2016	E4	A2	U2018	A3	A2
C1031	A2	C1	R2017	E4	A2	U2018	B3	A2
C1043	A2	D1	R2018	F4	A2	U2022	A3	B2
C1057	C1	E1	R2019	D4	A2	U2022	B3	B2
C1058	A2	E1	R2021	D4	B2	U2026	A3	B2
C2012	F4	A2	R2027	D4	B2	U2026	B4	B2
C2013	F4	A2	R2028	D4	B2	U2031	E2	C2
C2015	E3	A2	R3014	F4	A3	U2035B	E3	C2
C2016	E3	A2	R3015	F4	A3	U2035C	C1	C2
C2018	E4	A2	R3025	F3	B3	U2035D	C4	C2
C2020	E3	A2	R3026	E3	B3	U2035E	E3	C2
C2022	A2	B2	R3027	D4	B3	U2035F	A4	C2
C2026	E3	B2	R3028	F3	B3	U2035A	A1	C2
C2031	A2	C2				U2035	A4	C2
C2038	A2	C2	TP1036	F2	C1	U2039B	E3	C2
C2042	A2	D2	TP1038	D1	C1	U2039C	C4	C2
C2056	A2	E2	TP1056	A2	E1	U2039A	B2	C2
C3025	F3	B3				U2039	C3	C2
C3026	E4	B3	U1016A	F2	A1	U2044A	B1	D2
C3027	E4	B3	U1016B	F2	A1	U2044B	E1	D2
C3028	E3	B3	U1020A	F2	B1			
C3049	A2	D3	U1020B	F2	B1	U2044C	B4	D2
C3056	A2	E3	U1020C	F2	B1	U2044D	B1	D2
C3057	A2	E3	U1020	C3	B1	U2044	C3	D2
			U1025A	F1	B1	U2048	E1	D2
CR1012	F3	A1	U1025B	F4	B1	U2052	D2	E2
CR1013	F2	A1	U1025C	F1	B1	U2057	D1	E2
			U1025D	F1	B1	U3015	F4	A3
L3055	A2	E3	U1025	A4	B1	U3021A	F3	B3
L3056	A2	E3	U1028A	B4	B1	U3021B	F3	B3
L3059	A2	E3	U1028B	C3	B1	U3029	E3	B3
			U1028C	F1	B1	U3034	B1	C3
Q2024	D4	B2	U1028	A4	B1	U3038	B1	C3
Q3018	F4	A3	U1033A	C4	C1	U3042	D1	D3
			U1033B	C3	C1	U3047	D3	D3
R1014	B2	A1	U1033C	F1	C1	U3051	A1	E3
R1015	F2	A1	U1033	C3	C1			
R1016	F2	A1	U1037A	F1	C1	VR1025	F4	B1
R1017	F2	A1	U1037B	E1	C1	VR1029	F4	B1
R1026	F4	B1	U1037C	F1	C1			
R1033	E4	C1	U1037	C3	C1	W1039	C2	C1
R1040	C2	C1	U1041A	F1	D1	W1041	C1	D1
R1042	C1	D1	U1041B	D1	D1	W2057	B2	E2
R1056	C1	E1	U1046	C2	D1	W2058	D3	E2

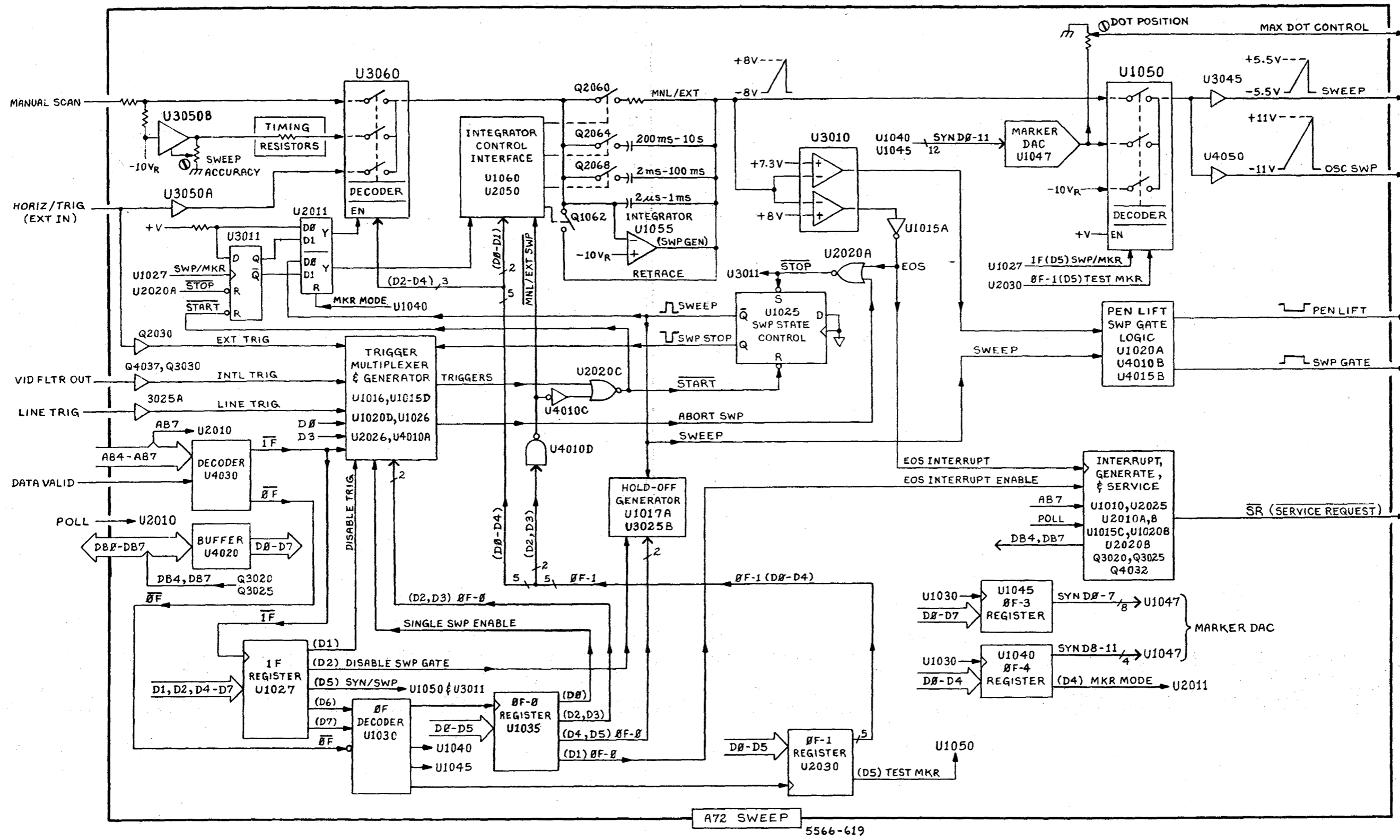

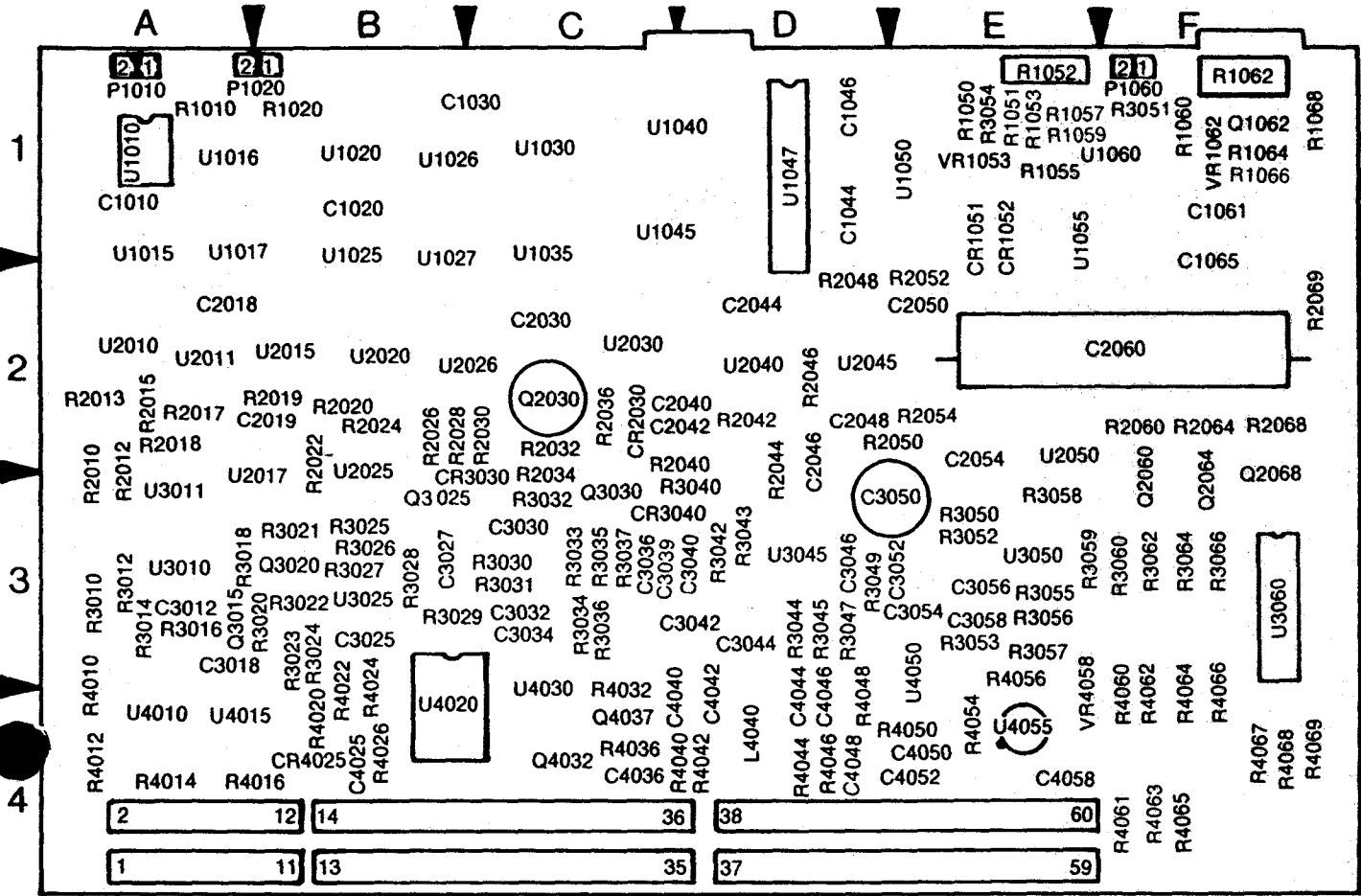

670-7915-

5566-618

Fig. 10-43. A72—Sweep circuit board.

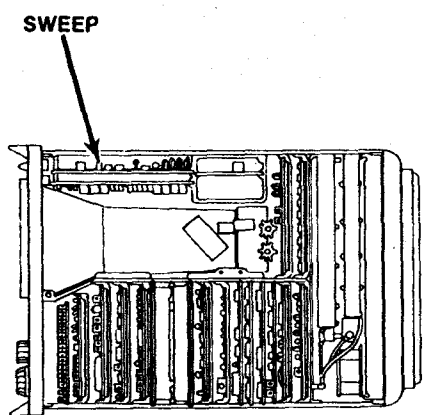

5566-620

SWEEP



ASSEMBLY A72

CIRCUIT NUMBER	SCHEM LOCATION	BOARD LOCATION	CIRCUIT NUMBER	SCHEM LOCATION	BOARD LOCATION	CIRCUIT NUMBER	SCHEM LOCATION	BOARD LOCATION	CIRCUIT NUMBER	SCHEM LOCATION	BOARD LOCATION
C1010	A3	A1	R1060	C1	F1	R4022	B4	B3			
C1020	C2	B1	R1062	A1	F1	R4024	B4	B3			
C1030	C4	C1	R1064	C2	F1	R4026	A4	B4	U1050	E1	E1
C1044	D1	D1	R1066	C2	F1	R4032	A3	C3	U1055	C2	E1
C1046	D1	D1	R1068	A1	F1	R4036	A3	C4	U1055	E4	E1
C1061	C1	F1	R2010	E1	A3	R4040	F2	C4	U1060	B1	F1
C1065	C1	F2	R2012	E1	A3	R4042	F2	D4			
C2018	B3	A2	R2013	E2	A2	R4044	F3	D4	U2010A	E4	A2
C2019	B3	B2	R2015	E2	A2	R4046	F3	D4	U2010B	E3	A2
C2030	D4	C2	R2017	E2	A2	R4048	F1	D4	U2010C	D3	A2
C2040	A3	C2	R2018	B2	A2	R4050	F1	E4	U2010D	C3	A2
C2042	A3	C2	R2019	C3	B2	R4054	F1	E4			
C2044	D1	D2	R2020	A4	B2	R4056	F3	E3			
C2046	A2	D2	R2022	C3	B2	R4060	B1	F3	U2010	F4	A2
C2048	D1	D2	R2024	E3	B2	R4061	A1	F4	U2011	B2	A2
C2050	E1	E2	R2026	E4	B2	R4062	B1	F3			
C2054	F3	E2	R2028	E4	B2	R4063	A1	F4	U2015A	B3	B2
C2060	C1	F2	R2030	A3	C2	R4064	A1	F3	U2015B	B4	B2
C3012	E2	A3	R2032	A2	C2	R4065	A1	F4	U2017	B3	B3
C3018	A4	A3	R2034	A3	C3	R4066	A1	F3	U2020A	B3	B2
C3025	B4	B3	R2036	A3	C2	R4067	A1	F4	U2020B	E4	B2
C3027	D2	B3	R2040	B3	C2	R4068	A1	F4	U2020C	A2	B2
C3030	D3	C3	R2042	D2	D2	R4069	A1	F4			
C3032	D2	C3	R2044	A2	D2						
C3034	A3	C3	R2046	D1	D2	U1010B	F3	A1	U2025A	F3	B3
C3036	A3	C3	R2048	D1	D2				U2025B	E4	B3
C3036	A3	C3	R2050	D1	D2	U1010A	E3	A1			
C3039	A3	C3	R2052	E1	E2	U1010	F4	A1	U2025	F4	B3
C3039	A3	C3				U1015A	E2	A1			
C3040	E1	D3	R2054	D1	E2	U1015B	A2	A1			
C3042	F2	D3	R2060	C1	F2	U1015C	E3	A1			
C3044	F3	D3	R2064	C1	F2	U1015D	B3	A1			
C3046	F1	D3	R2068	C1	F2	U1015E	B3	A1			
C3050	F3	D3	R2069	C1	F2						
C3052	E1	E3	R3010	F2	A3				U2026	E2	C2
C3054	F1	E3	R3012	F2	A3						
C3056	A2	E3	R3014	E2	A3	U1016A	D3	A1			
C3058	A2	E3	R3016	E2	A3	U1016B	E2	A1			
C4025	A4	B4	R3018	F4	A3	U1016	F4	A1			
C4036	A3	C4	R3020	F4	B3	U1017A	C2	A1			
C4040	F2	C4	R3021	E4	B3	U1017B	C3	A1			
C4042	F2	D4	R3022	B4	B3						
C4044	F3	D4	R3023	B4	B3				U2030	D4	C2
C4046	F3	D4	R3024	A4	B3						
C4048	F3	D4	R3025	E4	B3				U2040	D1	D2
C4050	F1	E4	R3026	D2	B3				U2040	E4	D2
C4052	F1	E4	R3027	D3	B3				U2045	D1	D2
C4058	A1	E4	R3028	D3	B3	U1020A	F2	B1	U2045	E1	D2
			R3028	D3	B3	U1020B	F4	B1	U2050	B1	E2
			R3028	D3	B3	U1020C	B3	B1			
			R3029	D2	B3	U1020D	D2	B1			
CR1051	C1	E1	R3030	D2	C3	U1020	F4	B1	U3010	E2	A3
CR1052	C1	E1	R3030	F4	C3	U1025A	C2	B2	U3011	B2	A3
CR2030	A2	C2	R3031	C2	C3	U1025B	A4	B2			
CR3030	D3	C3	R3032	A3	C3	U1025	F4	B2	U3025A	A4	B3
CR3040	A3	C3	R3033	A3	C3	U1026A	B3	B1	U3025B	D2	B3
CR4025	A4	B4	R3034	F4	C3	U1026B	D1	B1	U3025	B4	B3
			R3035	A3	C3						
L4040	F2	D4	R3036	F4	C3				U3045	F1	D3
			R3037	A3	C3				U3050A	A1	E3
P1010	E3	A1	R3040	A3	D3				U3050B	A1	E3
P1020	D3	A1	R3042	F1	D3	U1027	C3	B2	U3050	B4	E3
P1060	C1	F1	R3043	E1	D3				U3060	B1	F3
			R3044	F1	D3						
Q1062	C2	F1	R3045	F1	D3						
Q2030	A2	C2	R3047	F1	D3						
Q2060	C1	F3	R3049	E1	D3	U1030	C4	C1	U4010A	D3	A4
Q2064	C1	F3	R3050	A1	E3				U4010B	F2	A4
Q2068	C1	F3	R3051	F1	F1				U4010C	A2	A4
Q3015	C4	A3	R3052	A1	E3				U4010D	A2	A4
Q3015	F4	A3	R3053	A1	E3	U1035	D3	C1			
Q3020	E4	B3	R3054	F1	E1				U4010	F4	A4
Q3025	E4	B3	R3055	A1	E3				U4015A	B4	A4
Q3030	B3	C3	R3056	A1	E3				U4015B	F2	A4
Q4032	F4	C4	R3057	A1	E3				U4020	C4	B4
Q4037	A3	C4	R3058	B1	E3				U4030	A3	C3
			R3059	A1	E3	U1040	D4	D1			
R1010	D3	A1	R3060	A1	F3				U4050	E4	E3
R1020	F2	B1	R3062	A1	F3				U4050	F1	E3
R1050	C1	E1	R3064	A1	F3	U1045	E3	C1	U4055	F3	E4
R1051	C2	E1	R3066	A1	F3	U1047	D1	D1			
R1052	F1	E1	R4010	F2	A3						
R1053	C2	E1	R4012	F2	A4				VR1053	C1	E1
R1055	B2	E1	R4014	A4	A4				VR1062	C1	F1
R1057	C2	E1	R4016	A4	A4				VR4058	A1	E3
R1059	C2	E1	R4020	A4	B4						

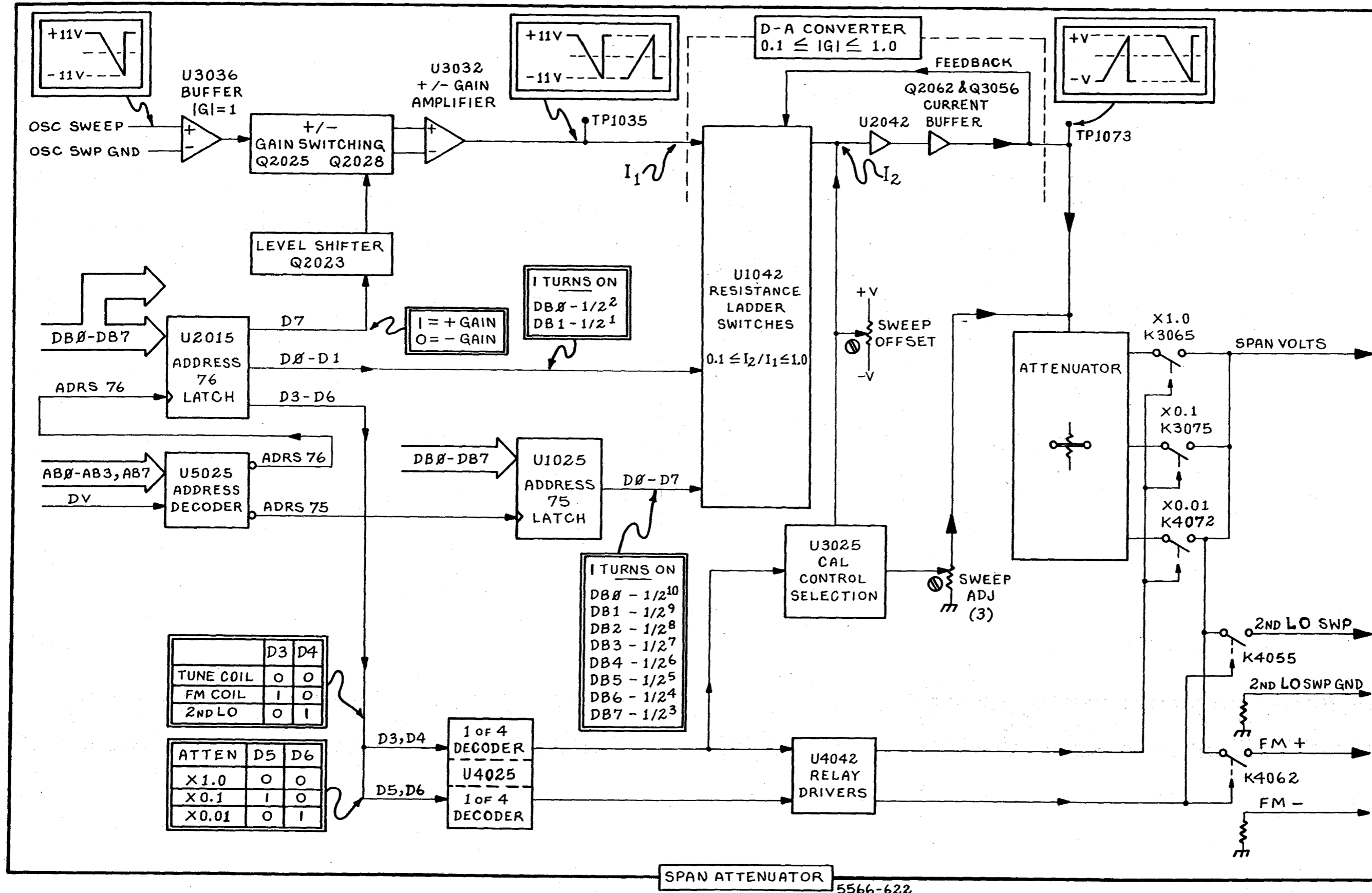

SPAN ATTENUATOR 5566-622

SPAN ATTENUATOR



ASSEMBLY A48A1

CIRCUIT NUMBER	SCHEM LOCATION	BOARD LOCATION	CIRCUIT NUMBER	SCHEM LOCATION	BOARD LOCATION	CIRCUIT NUMBER	SCHEM LOCATION	BOARD LOCATION
C1013	D2	A1	L4048	A3	D4	R2076	E2	G3
C1014	D3	A1	L4053	A3	D4	R3022	C2	B3
C1019	D2	A1	L4055	A4	E4	R3024	B1	B3
C1023	D2	A1				R3026	B1	B3
C1024	D2	B2	P2016	B1	A2	R3029	C1	B3
C1027	D2	B1				R3036	B1	C3
C1029	C1	B1	Q2023	B1	B3	R3038	A1	C3
C1032	D1	B1	Q2025	C1	B2	R3038	C1	C3
C1034	D2	C1	Q2028	C1	B2	R3042	D3	C3
C1036	C1	C1	Q2062	E1	F2	R3044	A1	D3
C1058	D1	E1	Q3056	E1	E3	R3046	D3	D3
C2024	B2	B2				R3047	F3	D3
C2026	A1	B2	R1013	C2	A2	R3048	A1	D3
C2035	D2	C2	R1014	C2	A2	R4032	C3	C4
C2036	D2	C2	R1019	C2	A1	R4034	C3	C4
C2037	C1	C2	R1023	C2	B1	R4035	C3	C4
C2042	D1	D1	R1024	C2	B1	R4036	C3	B4
C2044	E4	D2	R1027	C2	B1	R4037	C2	B4
C2050	E1	E2	R1032	C1	C1	R4038	C2	C4
C2052	D2	E2	R1033	D1	C1	R4056	B4	E5
C3031	C3	C4	R1034	C1	C1	R4064	E2	F5
C3032	C3	C4	R1046	D2	D1	R4065	E2	G2
C4035	C3	C4	R1052	D1	E1	R4066	E2	F3
C4038	B4	C4	R1054	E1	E1	R5052	A3	D4
C4056	B4	E4	R1056	D1	E1	R5058	F4	E5
C5018	A2	A5	R1058	E1	E1	R5068	F3	F5
C5038	B3	C5	R1059	E1	E1			
C5048	B3	D4	R1063	D2	F1	TP1035	C1	C1
C5055	A4	E5	R1065	E3	F1	TP1073	E1	G2
			R1067	E3	F1			
CR1049	D1	D1	R1071	E3	F1			
CR1051	D1	E1	R1077	E2	G2	U1025	C1	B2
CR1056	E1	E1	R2019	B1	B2	U1042	D1	D1
CR1061	E1	F1	R2022	B1	A2	U2015	A1	A2
CR2051	E1	E1	R2035	C2	C2			
CR2053	E1	E2	R2036	C2	C2	U2042	D1	D2
CR3056	F3	E3	R2038	C1	C2	U2042	F4	D2
CR4056	E3	E4	R2044	D3	D3	U3025	D3	B3
CR4062	E3	F3	R2046	D1	D2	U3032	C1	C2
CR4068	E3	F5	R2048	E2	D2	U3032	F4	C2
CR4069	E3	G4	R2049	E1	E2	U3036	A1	C3
			R2050	E1	E2	U3036	E4	C3
K3065	F2	F3	R2051	E2	E2	U4015	B2	A4
K3075	F2	G4	R2053	E1	E2	U4025	B3	B4
K4055	F3	E4	R2066	E2	F2	U4042	E3	D4
K4062	E4	F5	R2068	E2	G3	U5025	A2	B5
K4072	F2	G5	R2072	E2	G3			
			R2074	E2	G3	VR1044	D1	D1

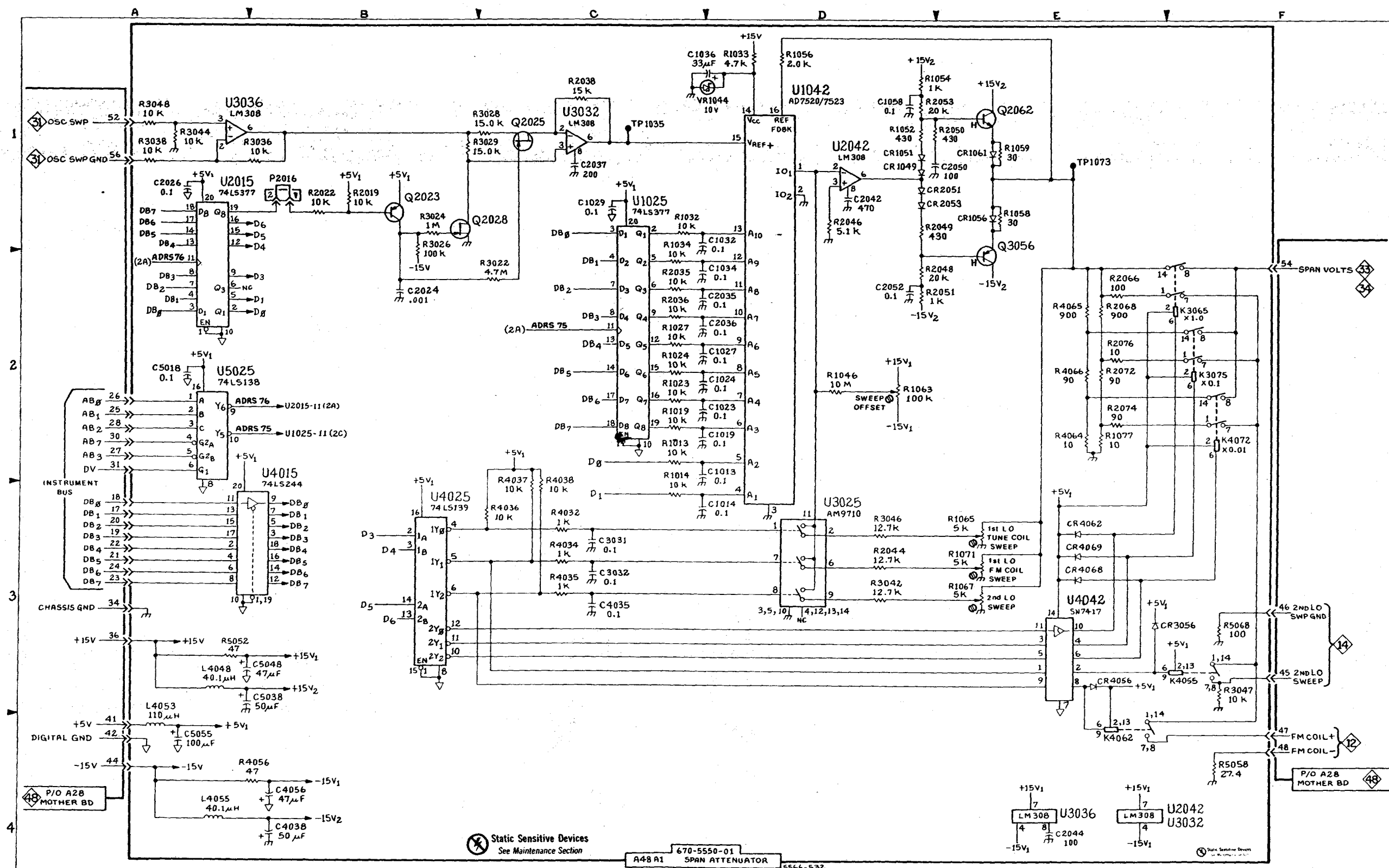

Static Sensitive Devices
See Maintenance Section

670-5550-01
A48 A1 SPAN ATTENUATOR 5566-532

494A/494AP

SPAN ATTENUATOR

1st LO DRIVER



ASSEMBLY A44A1

CIRCUIT NUMBER	SCHEM LOCATION	BOARD LOCATION	CIRCUIT NUMBER	SCHEM LOCATION	BOARD LOCATION	CIRCUIT NUMBER	SCHEM LOCATION	BOARD LOCATION
C2025	B3	B2	R1031	C2	C1	R3046	D2	D3
C2032	B2	C2	R1032	D1	C1	R3048	C3	D3
C2042	B1	C2	R1034	C4	C1	R3049	D3	D3
C2043	B1	C2	R1035	C1	C1	R4012	B2	A4
C2044	C3	D2	R1036	C1	C1	R4014	B5	A4
C2045	D2	D2	R1037	C4	C1	R4015	B5	A4
C2046	D2	D2	R1038	B1	C1	R4037	B4	C4
C2048	D2	D2	R1039	B2	C1	R4038	B4	C4
C2050	C4	D2	R1040	D3	D1	R4043	A4	D4
C2051	C4	D2	R1041	D1	D1	R4044	A4	D4
C2054	D4	E2	R1042	D2	D1			
C2056	C5	E2	R1043	D2	D1	TP1058	D1	E1
C3019	A3	A3	R1044	D2	D1	TP1059	C3	E1
C3034	A2	C3	R1045	D3	D1			
C3039	B4	D3	R1046	D3	D1	U2032	B1	C2
C3045	D2	D3	R1047	D4	D1	U2032	A5	C2
C3046	B4	D3	R1048	D4	D1	U2043	D2	D2
C3047	A4	D4	R1049	D4	D1	U2043	A5	D2
C3048	C3	D3	R1050	D4	D1	U2052	D4	E2
C4014	B5	A4	R1051	D4	E1	U2052	A5	E2
C4046	A5	D4	R1052	C4	E1	U3014	C3	A3
			R1053	C3	E1	U3014	B5	A3
CR1052	D4	E1	R1054	D4	E1	U4017	A3	A4
CR1053	D4	E1	R1055	C4	E1	U4034	A2	A4
CR1054	D4	E1	R2026	B3	B2			
CR2024	B3	B2	R2027	B1	B2	VR1055	C5	E1
CR3031	B2	C3	R2029	B3	B2			
CR3044	C3	D3	R2031	B1	C2	W2034	B1	C2
CR3047	D2	D3	R2036	C1	C2	W2045	C3	D2
			R2037	C3	C2			
K3034	B2	C3	R2041	C1	D2			
L4038	B4	C4	R2042	C3	D2			
L4041	A4	D4	R2043	C2	D2			
			R2044	C3	D2			
P3043	D2	D3	R2051	C4	E2			
			R2052	C4	E2			
Q2029	B3	B2	R2053	C5	E2			
Q2035	C1	C2	R2054	C5	E2			
Q2039	C1	C2	R3012	B3	A3			
Q2040	C3	D2	R3028	B3	B3			
Q2045	D2	D2	R3031	B4	B3			
Q2051	D4	E2						
Q2052	C4	E2						
Q3028	B4	B3						
Q3047	D2	D3						
Q352	C3	E3						

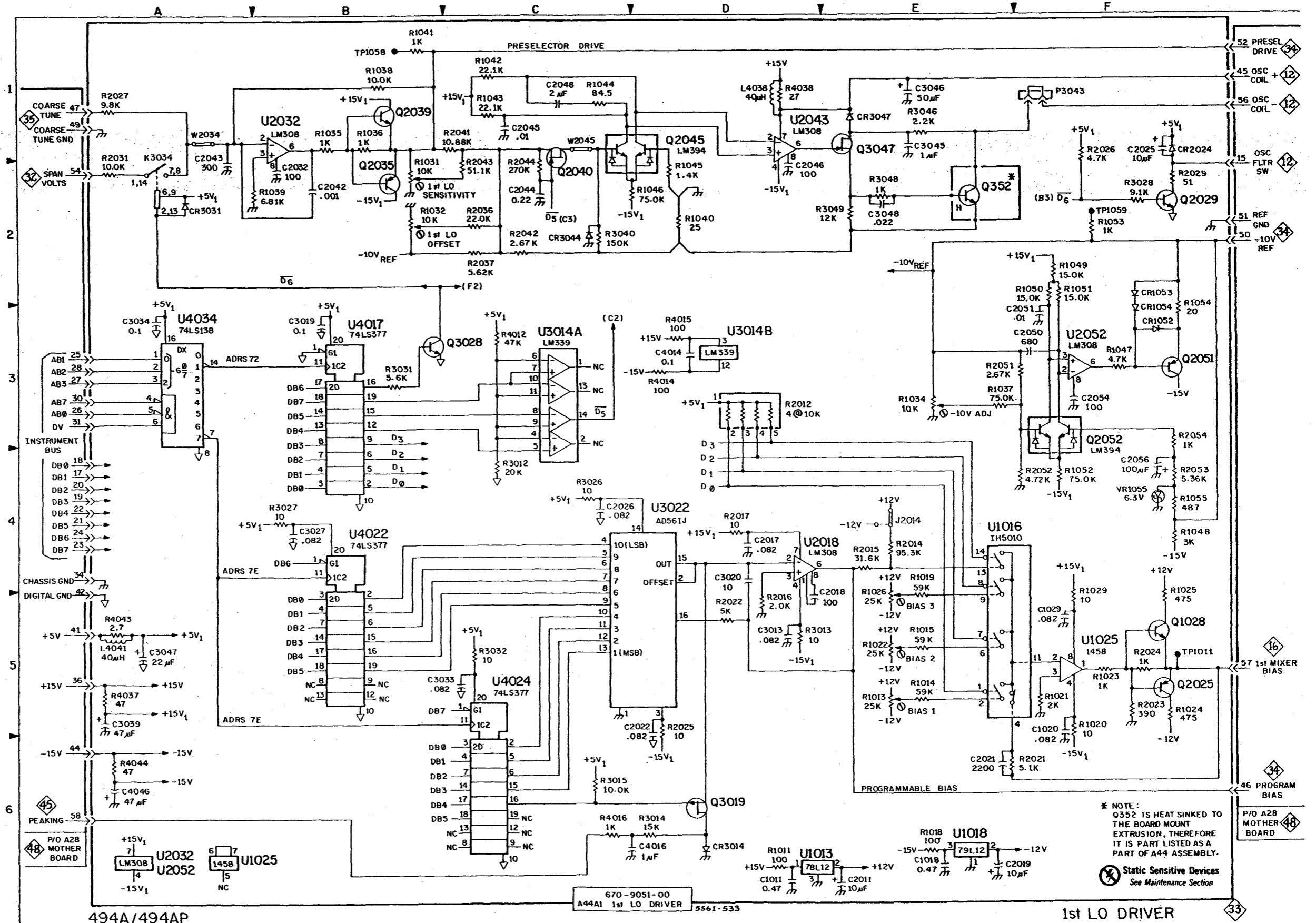

494A/494AP

670-9051-00
A44A1 1st LO DRIVER 5561-533

1st LO DRIVER

* NOTE:
Q352 IS HEAT SINKED TO THE BOARD MOUNT EXTRUSION, THEREFORE IT IS PART LISTED AS A PART OF A44 ASSEMBLY.

Static Sensitive Devices
See Maintenance Section

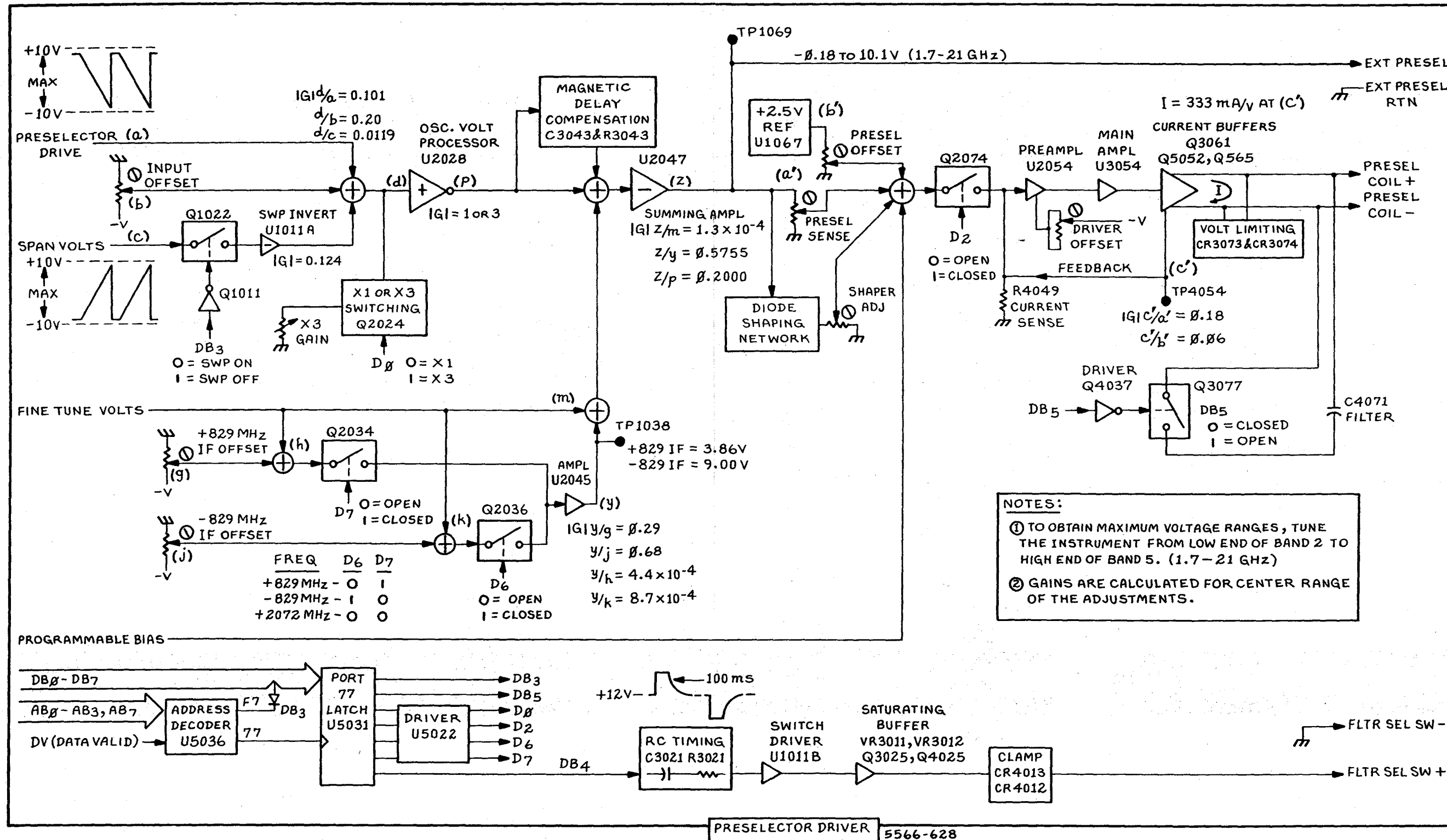

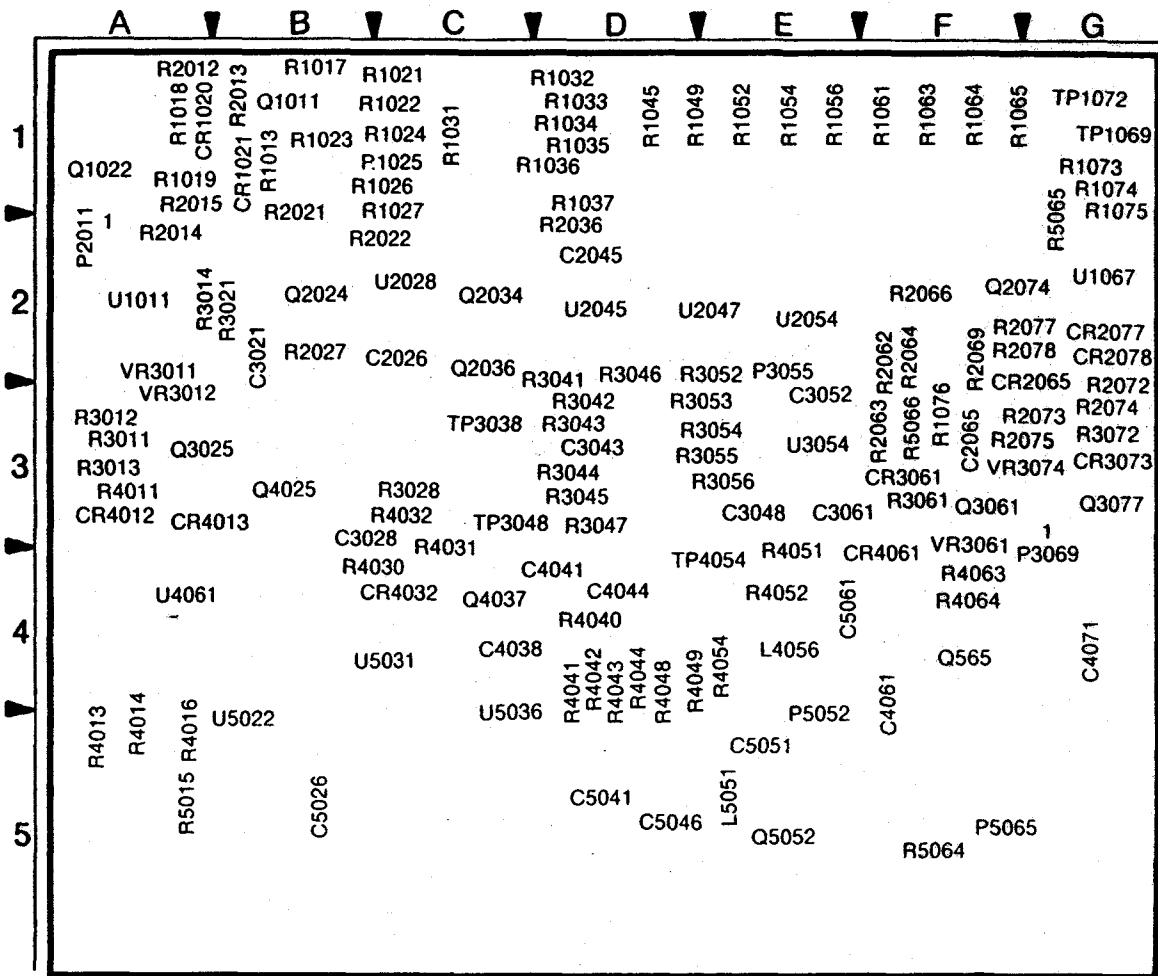

670-5552-

5666-627

Fig. 10-46. A42A1—Preselector Driver circuit board.

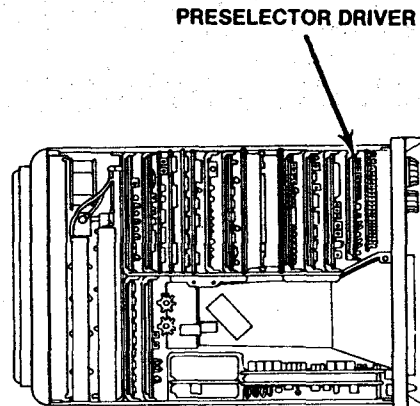

5566-629

I C4
7 12

PRESELECTOR DRIVER



ASSEMBLY A42A1

CIRCUIT NUMBER	SCHEM LOCATION	BOARD LOCATION	CIRCUIT NUMBER	SCHEM LOCATION	BOARD LOCATION	CIRCUIT NUMBER	SCHEM LOCATION	BOARD LOCATION	CIRCUIT NUMBER	SCHEM LOCATION	BOARD LOCATION
C2026	C4	C2	Q2036	B2	C2	R2022	B2	C2	R4044	E4	D4
C2045	C4	D2	Q2074	D1	G2	R2027	B1	B2	R4048	E2	D4
C2065	C4	F3	Q3025	E3	A2	R2036	B2	D2	R4049	E1	D4
C3021	D3	B2	Q3061	E1	F3	R2062	D2	F2	R4051	E1	E4
C3028	F3	B3	Q3077	F2	G3	R2063	D1	F3	R4052	E1	E4
C3043	C1	D2	Q4025	E3	B3	R2064	D1	F2	R4054	E1	E4
C3048	E1	E3	Q4037	E2	C4	R2066	D2	F2	R4063	E1	F4
C3052	D4	E3	Q5052	E1	E5	R2069	C2	F2	R4064	E1	F4
C3061	E2	E3				R2072	C2	G2	R5015	C4	A4
C4038	A4	C4	R1013	A1	B1	R2073	C2	G3	R5064	E2	F5
C4041	E3	D4	R1017	B1	B1	R2074	C2	G3	R5065	B3	G2
C4044	E4	D4	R1018	A1	A1	R2075	C2	G3	R5066	B3	F3
C4061	F2	F4	R1019	B1	A1	R2077	C2	G2			
C4071	F2	G4	R1021	B1	C1	R2078	C2	G2	TP1069	C1	G1
C5026	B3	B5	R1022	B1	C1	R3011	E3	A2	TP1072	D1	G1
C5041	E3	D5	R1023	B1	B1	R3012	E3	A2	TP3038	B1	C3
C5046	E4	D5	R1024	B1	C1	R3013	E3	A2	TP3048	C2	C3
C5051	F4	E5	R1025	B1	C1	R3014	E3	A2	TP4054	E1	E4
C5061	F2	E4	R1026	A2	C1	R3021	D3	B2			
			R1027	B1	C1	R3028	F3	C3	U1011A	B1	A2
CR1020	A1	A1	R1031	B1	C1	R3041	C2	D2	U1011B	E3	A2
CR1021	A1	B1	R1032	A2	D1	R3042	B1	D2	U1011	D4	A2
CR2065	D2	G2	R1033	B2	D1	R3043	C1	D2	U1067	D1	G2
CR2077	D2	G2	R1034	B2	D1	R3044	B2	D2	U2028	B1	C2
CR2078	D2	G2	R1035	B1	D1	R3045	A2	D2	U2028	C4	C2
CR3061	D2	F3	R1036	A2	D1	R3046	C2	D2	U2045	C2	D2
CR3061	E2	F3	R1037	B2	D1	R3047	C2	D2	U2045	C4	D2
CR3073	F2	G3	R1045	A2	D1	R3052	C2	E2	U2047	C1	E2
CR4012	E3	A2	R1049	A2	D1	R3053	C1	E3	U2047	C4	E2
CR4013	E3	A2	R1052	C1	E1	R3054	D1	E3	U2054	E1	E2
CR4032	B4	C4	R1054	D2	E1	R3055	C2	E3	U3054	D4	E3
			R1056	D2	E1	R3056	A2	E3	U3054	E1	E3
L4056	E2	E4	R1061	D2	F1	R3061	C2	F3	U4061	A4	A3
L5051	F3	E5	R1063	D2	F1	R3072	E2	G3	U4061	D4	A3
			R1064	D1	F1	R4011	E3	A2	U5022	C3	B5
P2011	B1	A2	R1065	C2	F1	R4013	C2	A4	U5031	C3	C4
P3055	D1	E2	R1073	D1	G1	R4014	B2	A4	U5036	B4	C5
P3069	F2	G3	R1074	D1	G1	R4016	C3	A4			
P5052	A3	E5	R1075	D1	G1	R4030	D3	B4	VR3011	E3	A2
P5065	B3	F5	R1076	D1	F3	R4031	D2	C3	VR3012	E3	A2
			R2012	A1	A1	R4032	E2	C3	VR3061	E2	F3
Q1011	A1	B1	R2013	A1	B1	R4040	D2	D4	VR3074	F2	G3
Q1022	A1	A1	R2014	B1	A2	R4041	E3	D4			
Q2024	B1	B2	R2015	B2	A1	R4042	E3	D4			
Q2034	B2	C2	R2021	B1	B1	R4043	E4	D4			

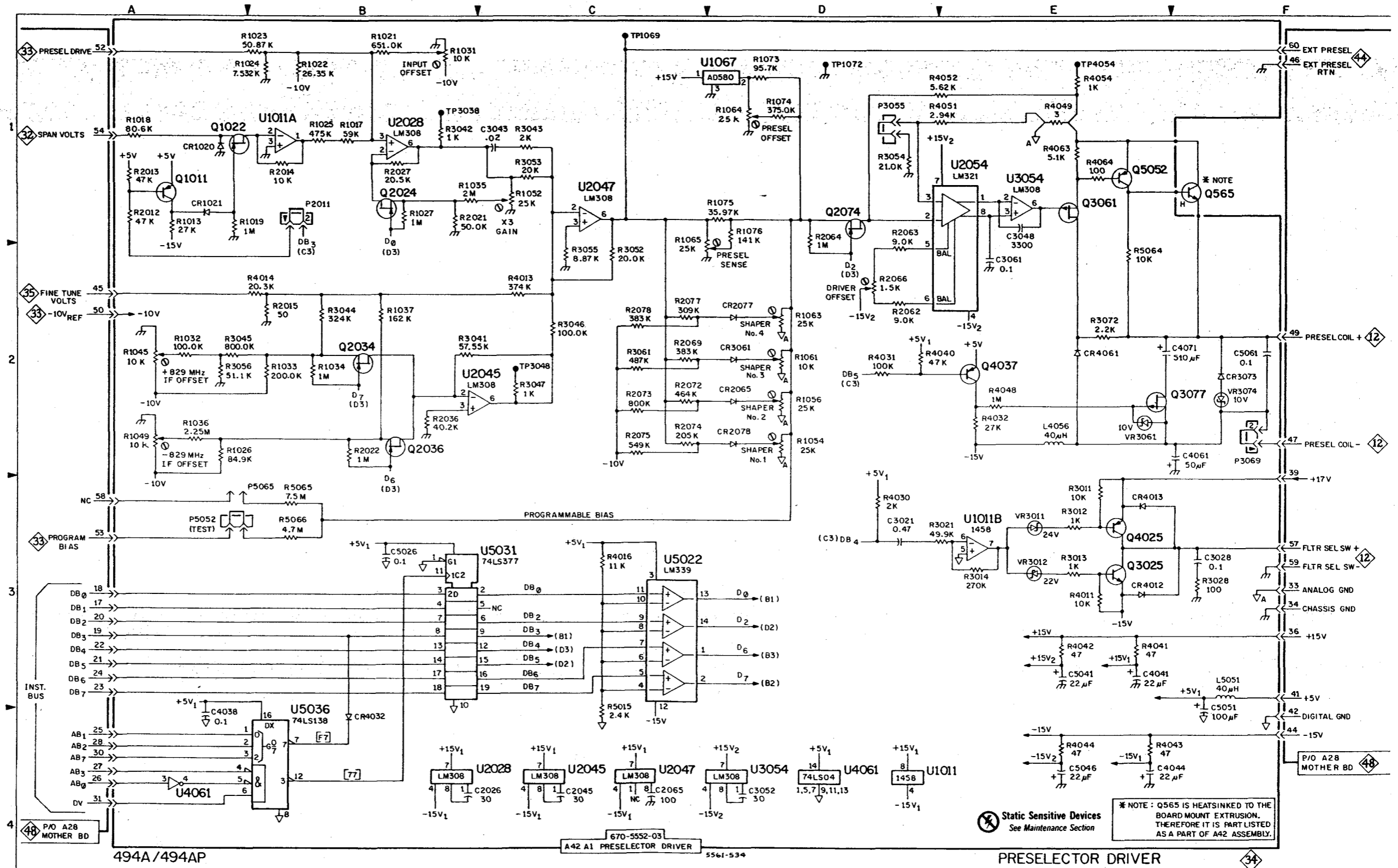

Static Sensitive Devices
See Maintenance Section

NOTE: Q565 IS HEATSINKED TO THE BOARD MOUNT EXTRUSION. THEREFORE IT IS PART LISTED AS A PART OF A42 ASSEMBLY.

PRESECTOR DRIVER

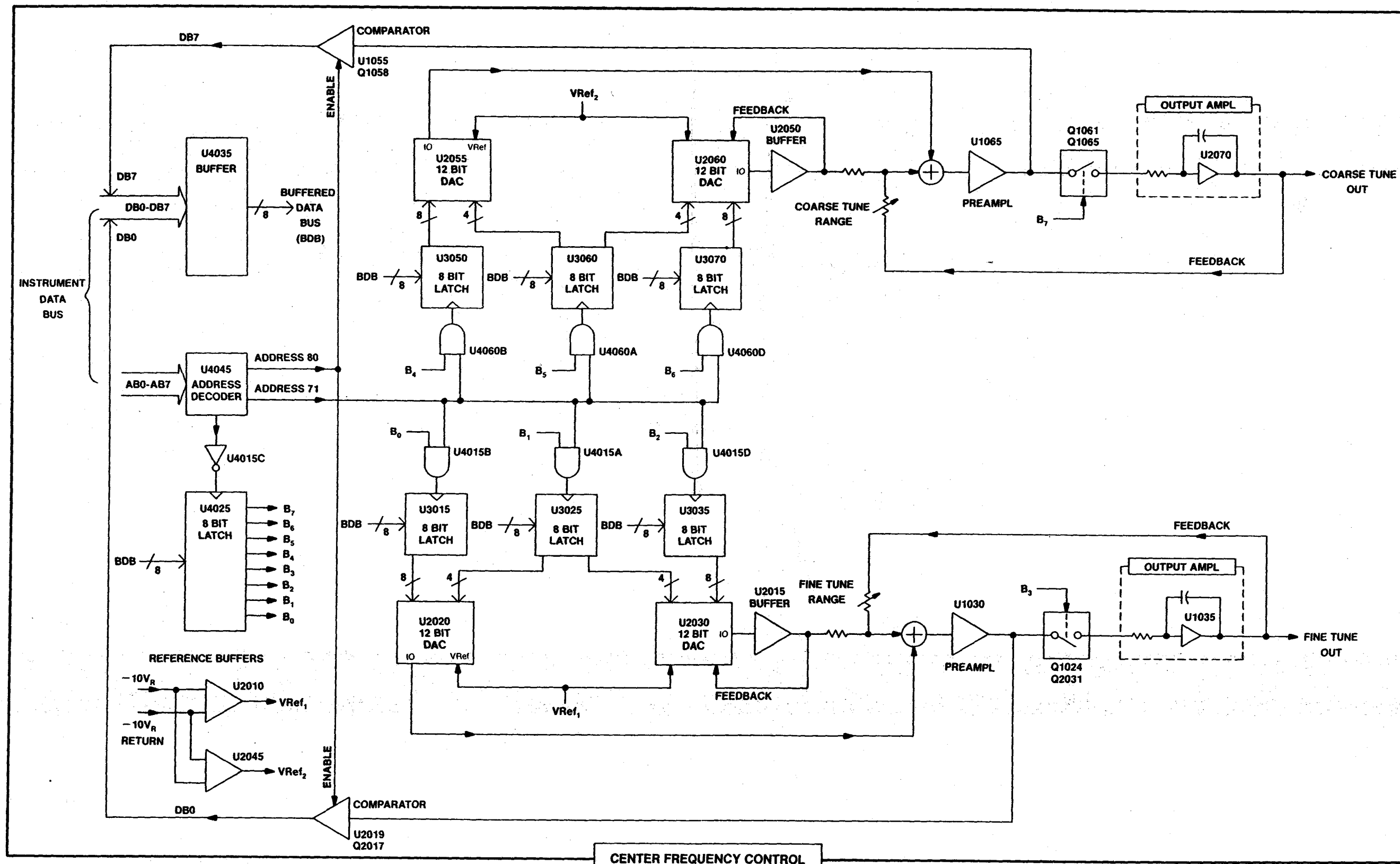

CENTER FREQUENCY CONTROL

5566-631

CENTER FREQUENCY CONTROL



ASSEMBLY A46A1

CIRCUIT NUMBER	SCHEM LOCATION	BOARD LOCATION	CIRCUIT NUMBER	SCHEM LOCATION	BOARD LOCATION	CIRCUIT NUMBER	SCHEM LOCATION	BOARD LOCATION
C1029	C4	B1	R1024	C1	B1	R3040	C2	A1
C1030	C2	C1	R1025	E1	B1	R3075	A3	G3
C1033	C4	C1	R1026	C2	B1	R4040	D2	C1
C1043	F1	D1	R1027	C2	B1	R4062	F2	G4
C1061	C4	F1	R1028	E3	D1	R4063	F3	G4
C1065	E2	F1	R1029	E2	B1			
C1066	C4	F1	R1030	E1	B1	U1030	C4	B1
C2015	C3	A2	R1031	E1	C1	U1030	D2	B1
C2037	A3	C2	R1032	E3	G1	U1035	B4	C1
C2040	A3	D2	R1033	E1	C1	U1035	F2	C1
C2043	A2	D2	R1034	F1	C1	U1055	B4	E2
C2050	E3	D2	R1035	F2	C1	U1055	D1	E2
C2069	A2	G2	R1036	D2	C1	U1065	C4	F1
C2074	A3	G2	R1039	F2	C1	U1065	E3	F1
C2076	F2	G1	R1048	A4	D1	U2010	A3	A2
C3040	A3	D3	R1049	A4	D1	U2010	A4	A2
C3045	B3	D3	R1050	A4	D1	U2015	A4	A2
C3076	A3	G3	R1051	B4	E1	U2015	C3	A2
			R1052	E4	E1	U2019	B4	A2
CR1024	C1	B1	R1053	E3	E1	U2019	C1	A2
CR1025	C1	B1	R1054	E2	E1	U2020	C1	B2
CR1026	F1	B1	R1055	E4	E1	U2030	C3	C2
CR1033	F1	C1	R1056	E2	E1	U2045	A4	D2
CR1035	F1	C1	R1057	D1	E1	U2045	B4	D2
CR1056	E2	E1	R1058	D1	E1	U2050	A4	D2
CR1058	E2	E1	R1059	E2	E1	U2050	E4	D2
CR1064	F2	F1	R1061	E3	F1	U2055	E2	E2
CR1067	F2	G1	R1062	E2	F1	U2060	E3	F2
CR1069	F2	G2	R1063	E2	F1	U2070	B4	G2
			R1064	E2	F1	U2070	F3	G2
L4055	A2	E4	R1065	E2	F1	U3015	C1	A3
			R1066	E2	F1	U3025	C2	B3
Q1024	F1	B1	R1067	E2	F1	U3035	C3	C3
Q1058	D1	E1	R1068	F2	F1	U3050	D2	E3
Q1061	F2	F1	R1070	E3	G1	U3060	D3	F3
Q1065	F2	F1	R1073	F2	G2	U3070	D4	F3
Q2017	C1	A2	R1073	F2	G2	U4015A	B2	A4
Q2031	F2	C2	R2017	B1	A2	U4015C	A1	A4
			R2019	C1	A2	U4015D	B3	A4
R1011	A3	A1	R2028	C2	B2	U4015	B1	A4
R1012	A3	A1	R2029	C2	B2	U4015	C4	A4
R1013	A4	A1	R2038	A3	C2	U4025	B1	B4
R1014	A3	A1	R2039	A3	C2	U4035	A1	C4
R1015	B4	A1	R2046	A2	D2	U4045	A1	D4
R1015	D2	A1	R2059	E3	E2	U4060A	D3	G4
R1016	C3	A1	R2060	E3	F2	U4060B	D2	G4
R1020	C3	A1	R2061	E2	F2	U4060D	D4	G4
R1021	E1	B1	R2067	F2	F2	U4060	C4	G4
R1022	E1	B1	R2069	A2	G2			
R1023	C1	B1	R2074	A3	G3			

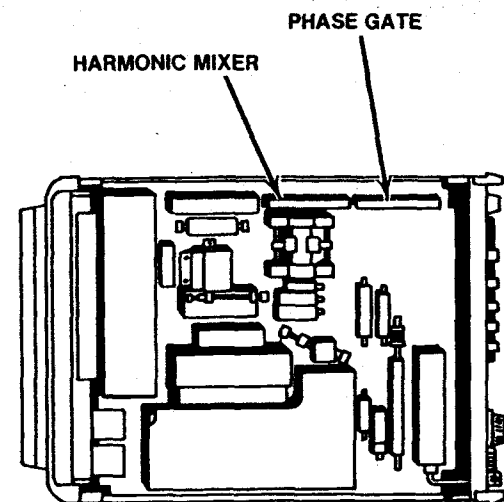

5566-633

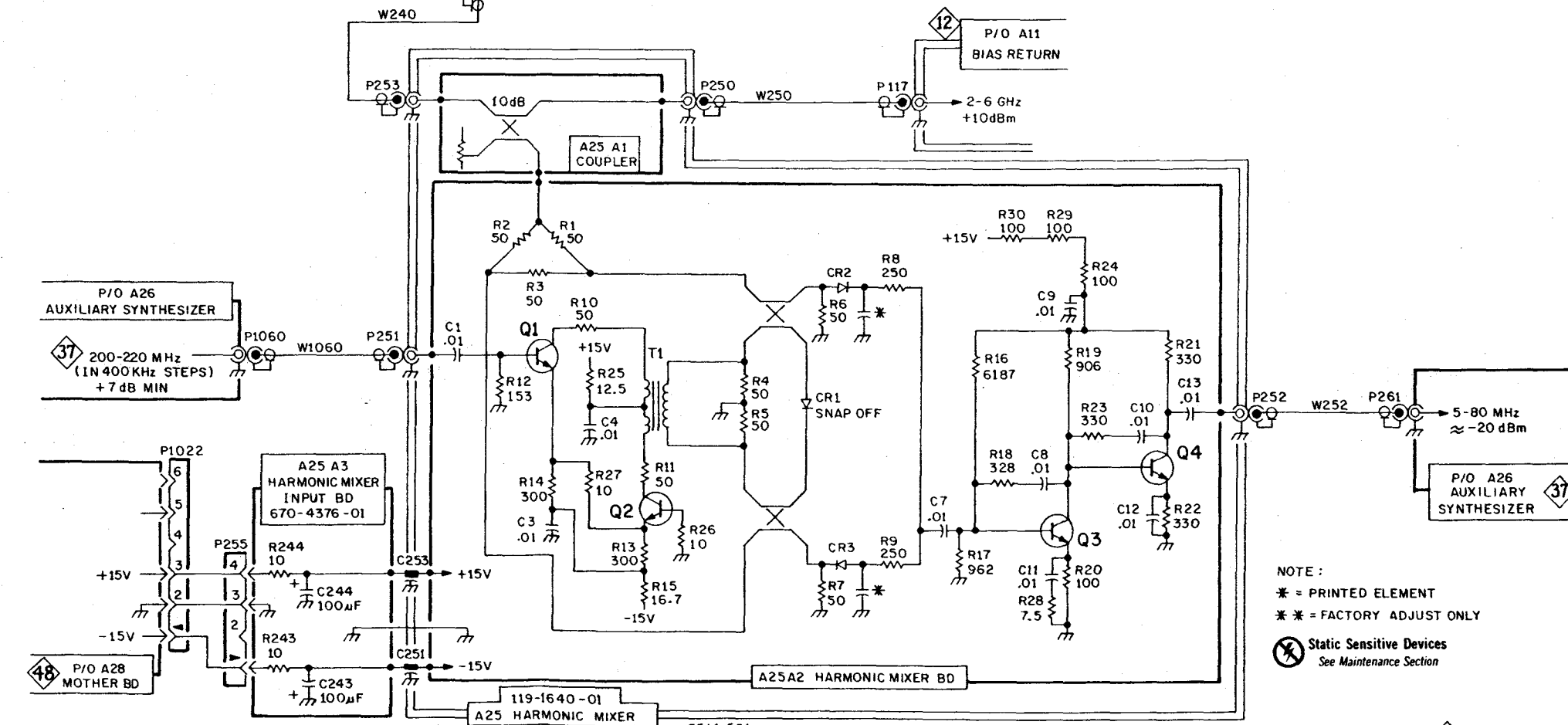
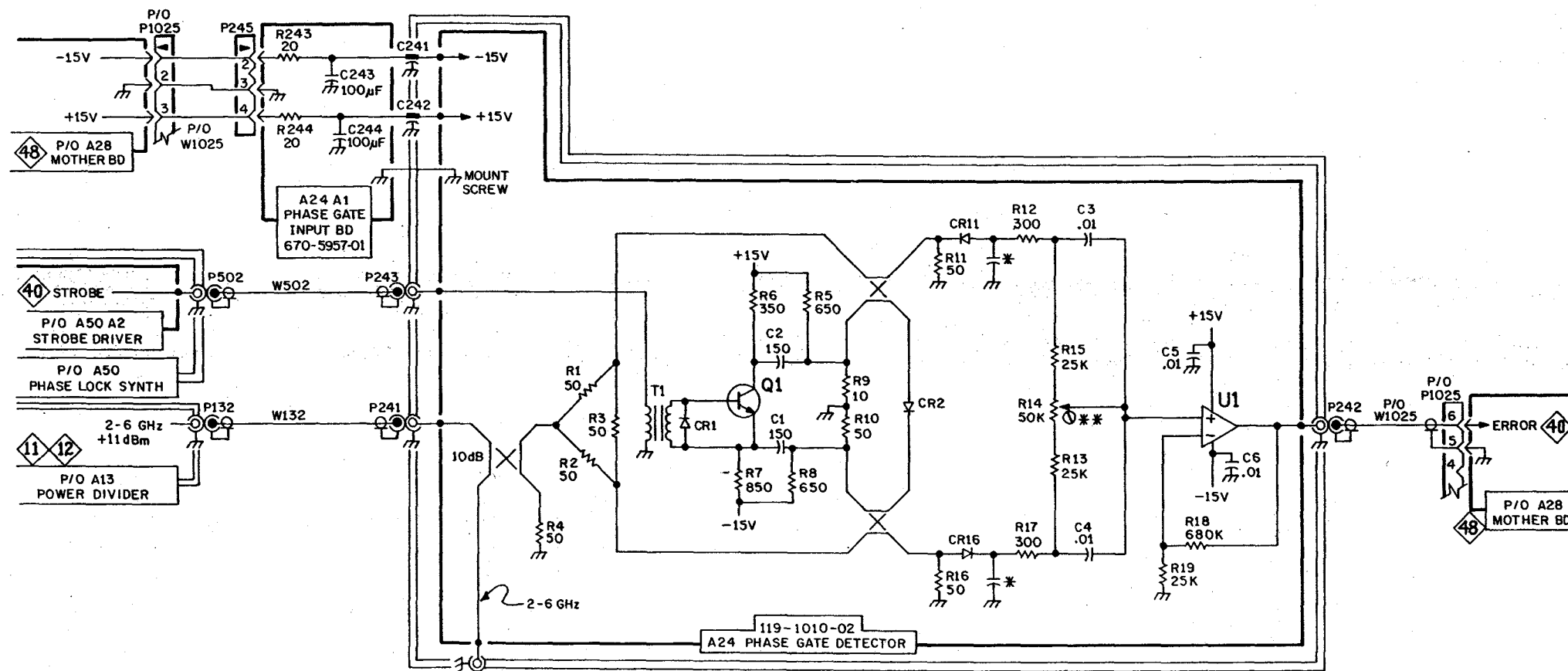

494 A/494 AP

5561-536

HARMONIC MIXER & PHASE GATE

NOTE:
* = PRINTED ELEMENT
** = FACTORY ADJUST ONLY

⊗ Static Sensitive Devices
See Maintenance Section

36

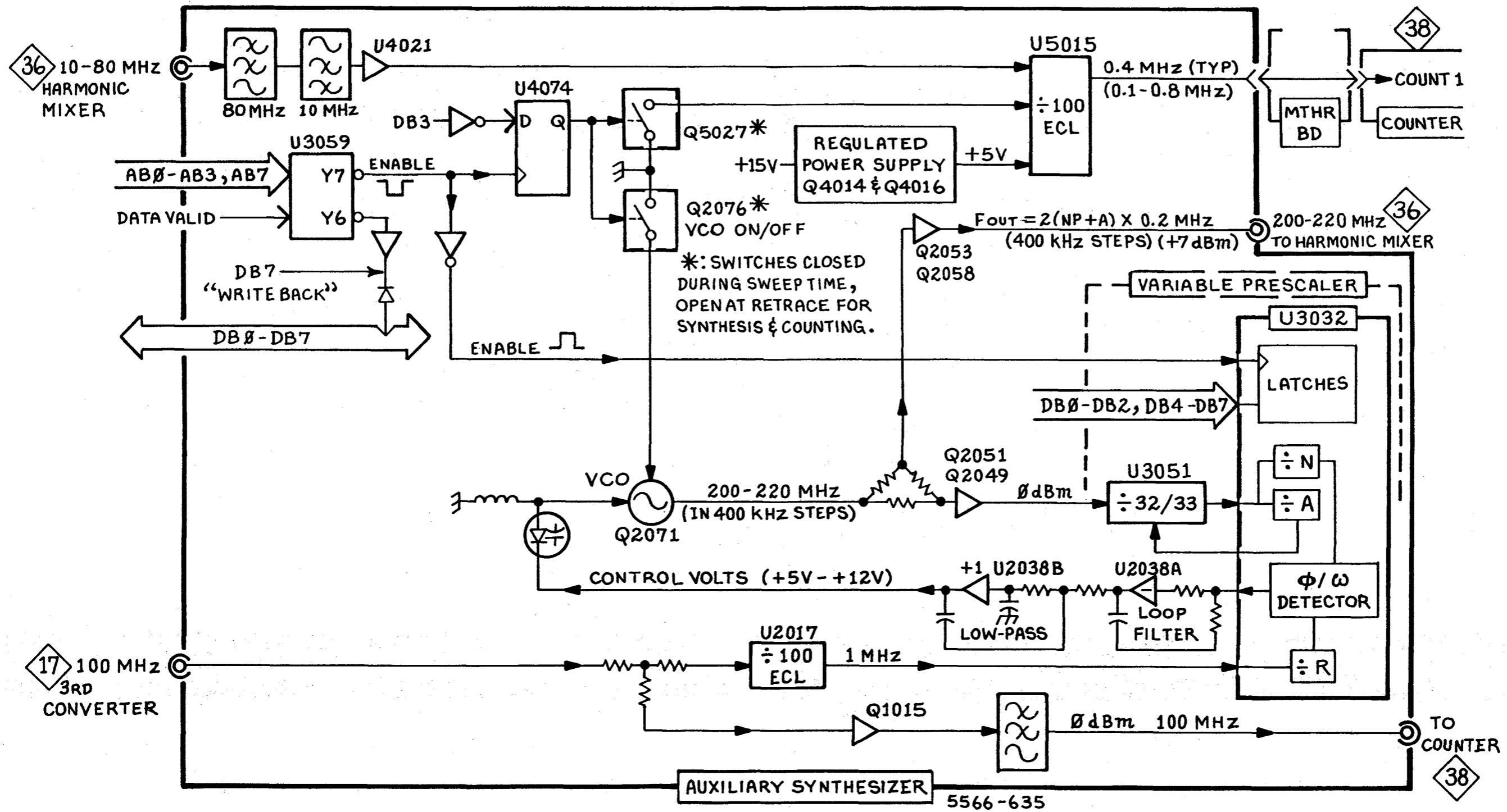

AUXILIARY SYNTHESIZER



ASSEMBLY A26A1

CIRCUIT NUMBER	SCHEM LOCATION	BOARD LOCATION	CIRCUIT NUMBER	SCHEM LOCATION	BOARD LOCATION	CIRCUIT NUMBER	SCHEM LOCATION	BOARD LOCATION	CIRCUIT NUMBER	SCHEM LOCATION	BOARD LOCATION
C1016	C5	A1	C3074	B2	G3	R1018	C5	A1	R3058	D3	E3
C1020	C5	A1	C4014	C1	A4	R1021	C5	B1	R3065	B3	F3
C1021	C5	B1	C4017	B1	A3	R1022	C4	B1	R3070	A2	G3
C1023	C5	B1	C4021	B1	B3	R1045	D2	D1	R3071	B3	G3
C1024	D5	B1	C4026	B1	B4	R1047	D3	D1	R3076	C2	G3
C1046	D2	D1	C4027	B1	B4	R1049	D2	D1	R4015	C1	A4
C1055	C2	E1	C4032	E4	C4	R1051	D2	E1	R4016	C1	A4
C1057	D2	E1	C4035	F4	C4	R1053	C2	E1	R4023	B1	B4
C1066	D4	F1	C4037	F2	C4	R1054	C2	E1	R4024	B1	B4
C1070	C3	G1	C4053	E3	E4	R1056	C2	E1	R4027	C2	B4
C2012	D4	A2	C5015	C1	A5	R1057	C1	E1	R4038	A3	C4
C2013	B5	A2	C5016	C1	A5	R1066	D3	F1	R4040	A3	D4
C2019	E4	A2	C5017	D1	A5	R1068	C3	F1	R4047	A3	D4
C2021	C4	A2	C5027	C2	B5	R2013	B5	A2	R4049	A3	E4
C2022	D5	B2	C5052	A4	E5	R2016	E4	A2	R4052	F3	E4
C2024	E4	B2	C5056	A4	E5	R2017	B4	A2	R4073	B1	G4
C2040	E3	C2	C5066	A3	F4	R2022	B4	B2	R5016	D1	A5
C2046	D3	D2	C5067	A3	F5	R2023	B4	B2	R5017	C1	A5
C2047	E3	D2	C5068	A3	F5	R2024	C4	B2	R5020	C1	B5
C2052	E2	E2	C5072	A3	G5	R2025	D5	B2	R5021	D1	B5
C2053	D2	E2				R2031	E3	C2	R5023	C2	B5
C2054	E3	E2	CR1065	D3	F1	R2032	E3	C2	R5024	C2	B5
C2055	C2	E2	CR2068	C3	F1	R2044	E3	D2	R5025	C2	B5
C2056	E2	E2	CR4070	A2	G4	R2047	D3	D2	R5038	A3	C5
C2059	D2	E2	CR4077	C2	G4	R2049	E3	D2	R5039	A3	C5
C2061	E2	F2				R2050	E3	E2	R5072	A3	G5
C2065	C3	F2	L1020	C5	B1	R2051	E2	E2			
C2066	C4	F1	L1074	B3	G1	R2056	D2	E2	T4014	B1	A4
C2067	C3	F2	L3014	A1	A3	R2057	E2	E2	T5022	B1	B4
C2068	C3	F2	L3016	A1	A3	R2058	E2	E2			
C2069	C3	F2	L3020	A1	B3	R2060	D2	F2	TP1066	D3	F1
C2071	C3	G2	L5059	A4	E5	R2065	D3	F2	TP1074	D4	G1
C2072	C3	G2				R2068	B3	F2	TP4045	F3	D4
C2073	C3	G2	P1028	A4	B1	R2071	B3	G2			
C2075	C3	G2	P1039	E5	C1	R2072	C3	G2	U2017	D4	A2
C3012	A1	A3	P1060	E2	F1	R2074	C3	G2	U2040A	E3	C2
C3016	A1	A3				R2075	C3	G2	U2040B	D3	C2
C3018	A1	A3	Q1015	C5	A1	R2076	C3	G2	U3051	F2	E3
C3022	A1	B3	Q2049	E3	D2	R3022	B1	B3	U3059	A1	E4
C3032	E4	C3	Q2051	D3	E2	R3037	F2	C3	U4021	B1	B4
C3035	E4	C3	Q2055	D2	E1	R3038	A3	C3	U4041	F2	D4
C3046	E4	D3	Q2058	E2	E2	R3041	E4	D3	U4066A	A2	F4
C3047	F4	D3	Q2071	C3	G2	R3042	F3	D3	U4066B	B2	F4
C3050	E3	E3	Q2076	C3	G2	R3043	E4	D3	U4066C	A2	F4
C3051	D3	E3	Q4014	C1	A4	R3044	F4	D3	U4066D	A2	F4
C3052	E2	E3	Q4016	D1	A4	R3045	F3	D3	U4066E	B2	F4
C3058	A1	E3	Q5027	C2	B4	R3046	F4	D3	U4066F	A2	F4
C3066	A2	F3				R3050	E3	E3	U4074	C2	G4
C3067	B3	F3	R1012	B5	A1	R3055	D3	E3	U5015	D1	A5
C3071	B3	G3	R1017	C5	A1	R3057	D3	E2	U5073	A3	G5

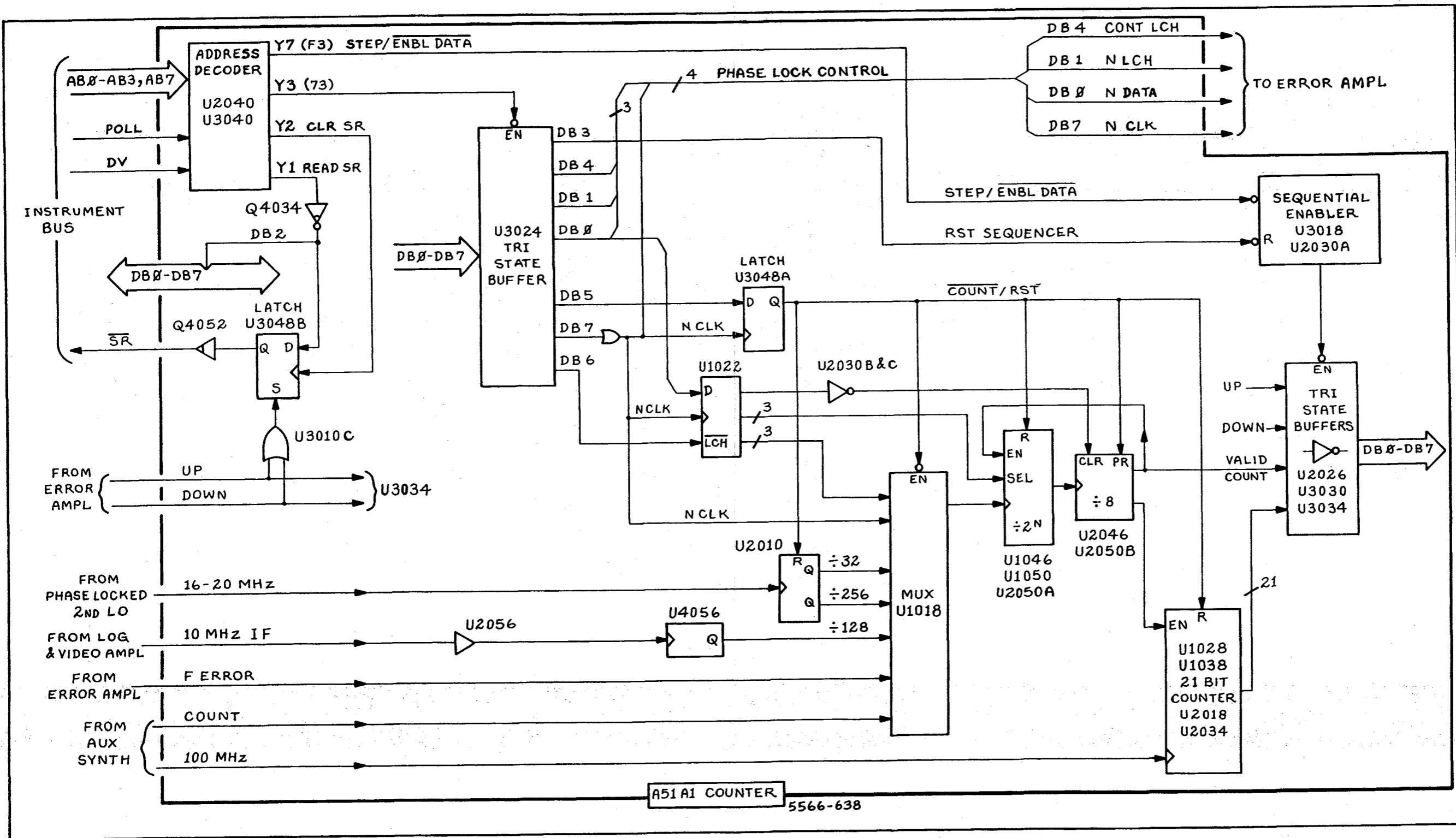

COUNTER



ASSEMBLY A51A1

CIRCUIT NUMBER	SCHEM LOCATION	BOARD LOCATION	CIRCUIT NUMBER	SCHEM LOCATION	BOARD LOCATION	CIRCUIT NUMBER	SCHEM LOCATION	BOARD LOCATION
C1014	B4	A1	R1012	B3	A1			
C1016	B3	A1	R1014	B4	A1			
C1038	A4	C1	R1016	B3	A1	U1018	C2	A1
C2010	B2	A3	R1020	C2	B1	U1022	C2	B1
C2034	B4	C2	R1021	C2	B1	U1028A	F3	B1
C2044	A4	D2	R1030	E4	C1	U1028B	F3	B1
C2046	D3	D2	R1032	D4	C1	U1038	D4	C1
C2050	B3	D2	R1034	E4	C1	U1046	D2	D1
C2052	B3	E2	R1042	D4	D1	U1050A	D3	D1
C2054	A3	E2	R1044	E4	D1	U1050B	D3	D1
C2056	A3	E2	R1046	C2	D1	U2010A	B3	A2
C2058	B3	E2	R1056	A3	E1	U2010B	C3	A2
C2059	B3	E2	R2022	E3	B2	U2018	E3	A2
C3010	A4	A3	R2030	F1	B2	U2026	F4	B2
C3020	E3	D4	R2032	D4	C2	U2030A	E1	B2
C3050	B4	E3	R2034	D4	C2	U2030B	C2	B2
C3052	B3	E3	R2036	C4	C2	U2034A	F2	C2
C3054	B3	E3	R2038	C4	C2	U2034B	F2	C2
C3058	A4	E3	R2042	D3	C2	U2040	A1	C2
C4042	A4	D4	R2044	E3	D2	U2046A	E2	D2
			R3010	B2	A3	U2046B	E3	D2
CR1012	B4	A1	R3012	B2	A3	U2050A	D3	D2
CR1030	D4	C1	R3030	E1	B3	U2050B	E2	D2
CR1040	E3	D1	R3034	E1	C3	U2056	B3	E2
CR1042	D4	D1	R3044	B3	D3	U2056	B3	E2
CR1044	E4	D1	R3048	B3	D3	U2056	B4	E2
CR2040	E4	C2	R3052	A3	E3	U3010A	B1	A3
CR2048	B3	D2	R3054	B4	E3	U3010B	B1	A3
CR3056	B3	E3	R3056	B3	E3	U3010C	A3	A3
CR3058	B3	E3	R3058	B3	E3	U3010D	E3	A3
CR4040	B2	C4	R4010	E3	C4	U3018	E1	A3
			R4018	F2	A4	U3024	B1	B3
L2056	A3	E2	R4020	F2	B4	U3030	F3	B3
L4016	A4	A4	R4028	A1	B4			
			R4036	A2	C4	U3034	F2	C3
P1036	A4	C1	R4038	A2	C4	U3040	A2	C3
P1056	A3	E1	R4050	B2	D4	U3046A	E3	D3
P2046	E3	D2	R4052	B2	D4	U3046B	C1	D3
P2047	B3	D2				U3046C	A3	D3
P3046	C1	D4	TP1056	A4	E1	U3046D	C1	D3
			TP1057	C3	E1	U3046E	C2	D3
Q1018	B4	A1	TP1058	A4	E1	U3046F	E2	D3
Q1034	E4	C1	TP2043	D1	D2	U3048A	C2	D3
Q1044	E4	D1	TP2044	D3	D2	U3048B	B2	D3
Q4034	B2	C4	TP2045	B2	D2	U4056A	B3	E3
Q4052	B2	E4	TP3036	F2	C3	U4056B	C3	E3
			TP4048	B2	D4			

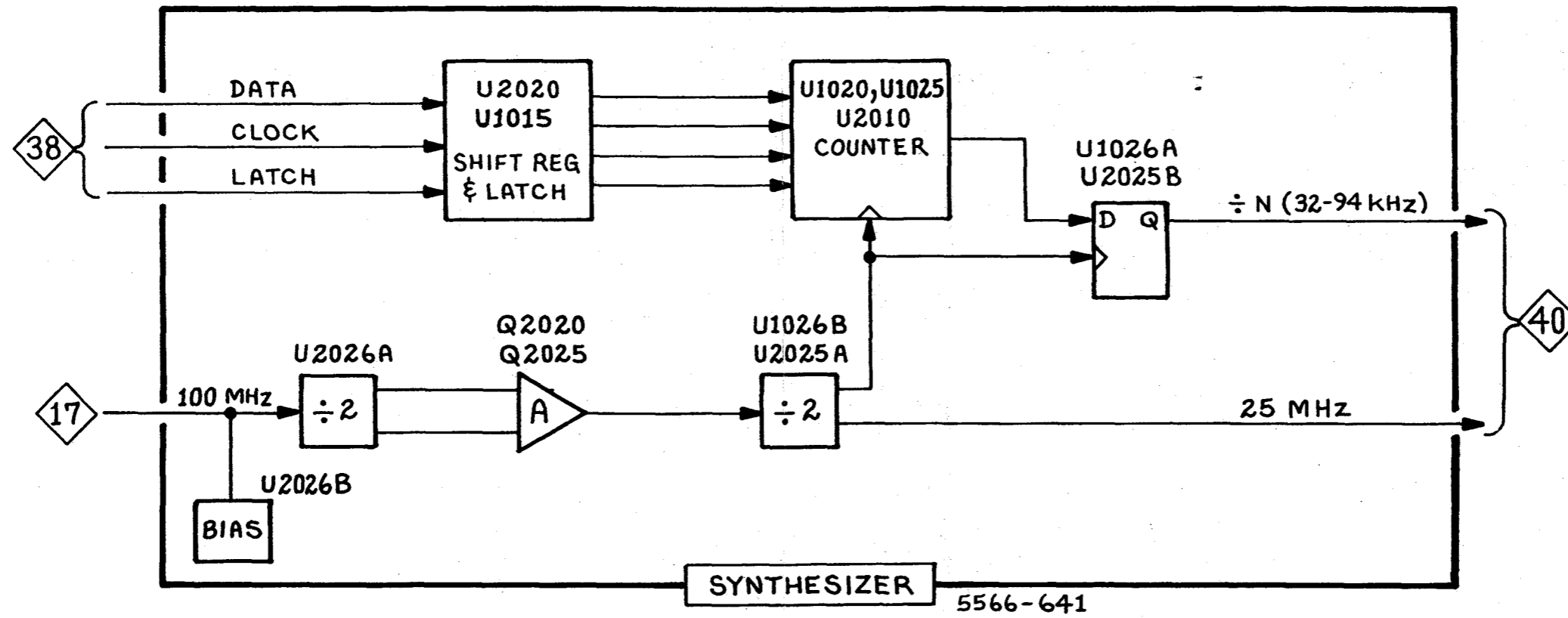

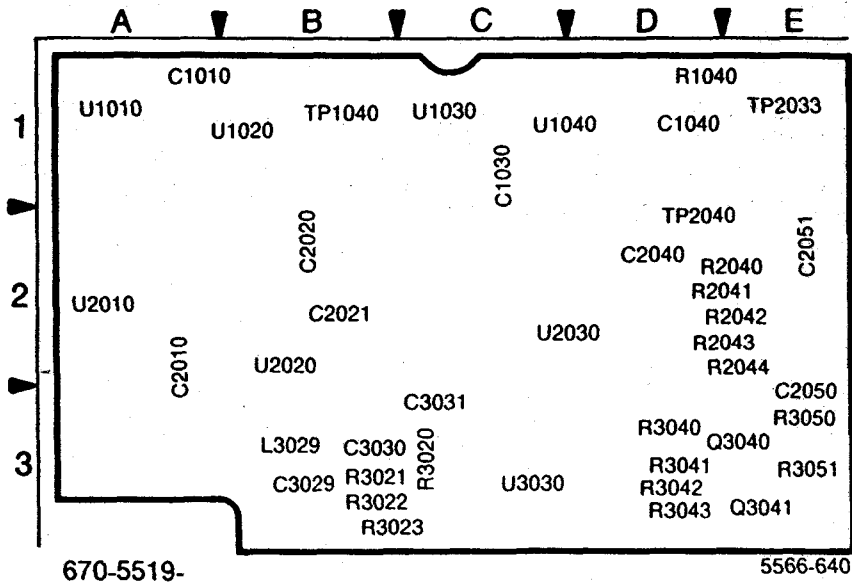
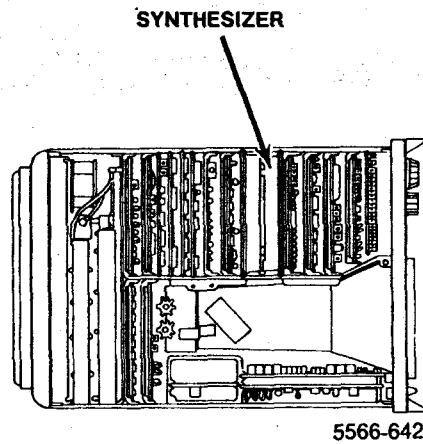

Fig. 10-50. A50A1—Synthesizer circuit board.



PHASE LOCK SYNTHESIZER (SYNTHESIZER)

39

ASSEMBLY A50A1

CIRCUIT NUMBER	SCHEM LOCATION	BOARD LOCATION	CIRCUIT NUMBER	SCHEM LOCATION	BOARD LOCATION
C1010	A1	A1	R3020	A3	C3
C1030	A1	C1	R3021	A3	B3
C1040	D2	D1	R3022	B3	B3
C2010	A1	A2	R3023	B3	B3
C2020	A1	B2	R3040	B3	D3
C2021	B1	B2	R3041	B3	D3
C2040	A2	D2	R3042	B3	D3
C2050	B3	E3	R3043	B3	D3
C2051	B1	32	R3050	B3	E3
C3029	A3	B3	R3051	B3	E3
C3030	A3	B3			
C3031	B2	C3			
			TP1040	D2	B1
L3029	A3	B3	TP2033	C3	E1
			TP2040	D2	D2
Q3040	B3	E3			
Q3041	B3	E3	U1010	A1	A1
			U1020	C1	B1
R1040	B3	D1	U1020	B2	B1
R2040	A1	E2	U1030	C2	C1
R2041	A1	D2	U1030	B2	C1
R2042	A1	E2	U1040	B2	D1
R2043	B2	D2	U1040A	D2	D1
R2044	B3	E2	U1040B	C3	D1
			U2010	B2	A2
			U2010	C1	A2
			U2020	C1	B2
			U2030	C2	C2
			U3030A	B3	C3
			U3030B	B3	C3

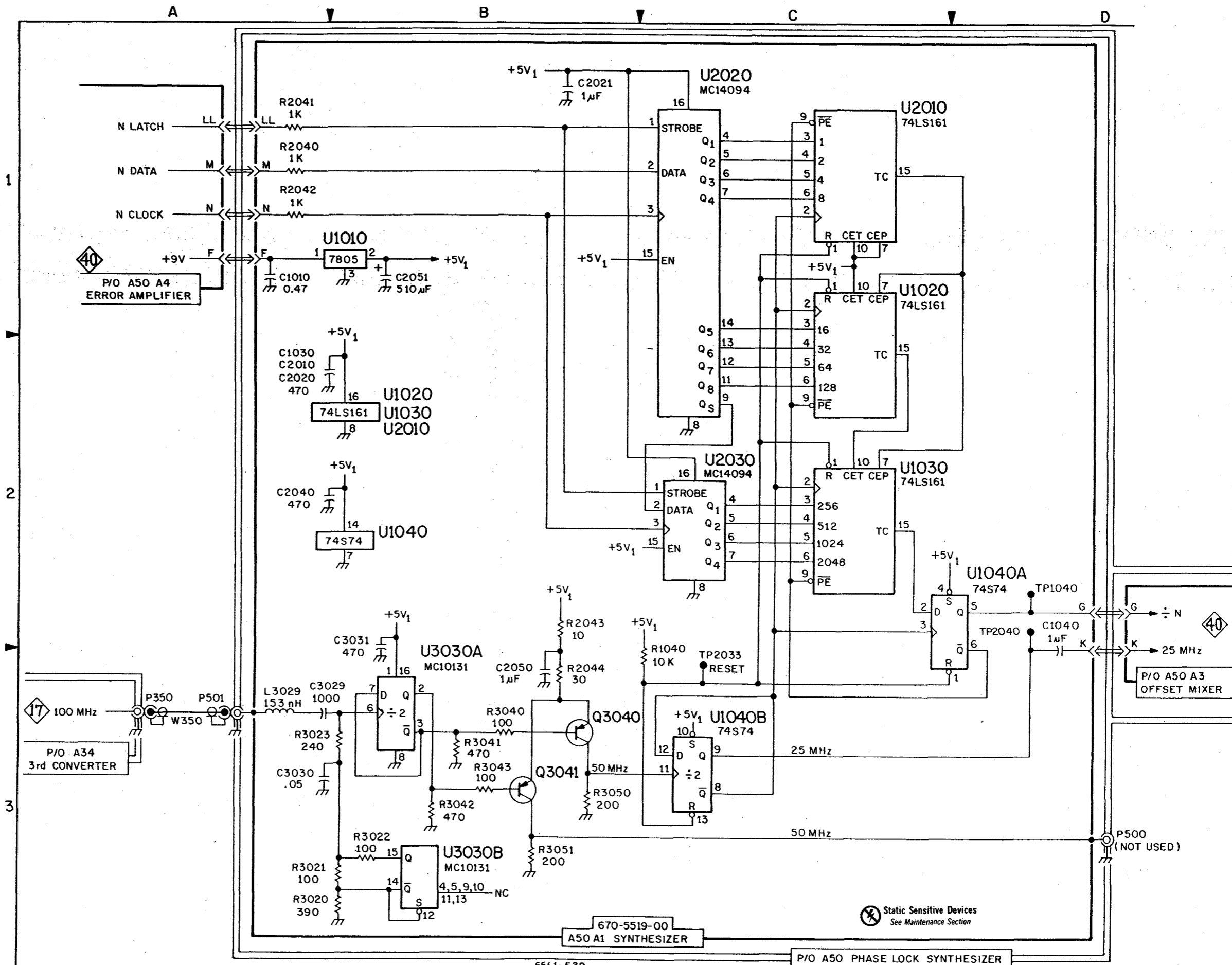

494 A / 494 AP

5561-539

P/O A50 PHASE LOCK SYNTHESIZER
 PHASE LOCK SYNTHESIZER (SYNTHESIZER)

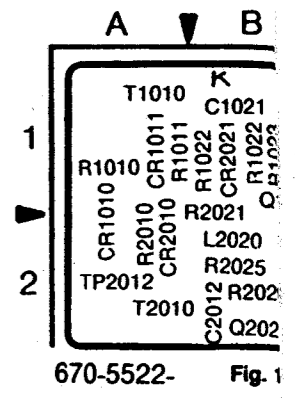
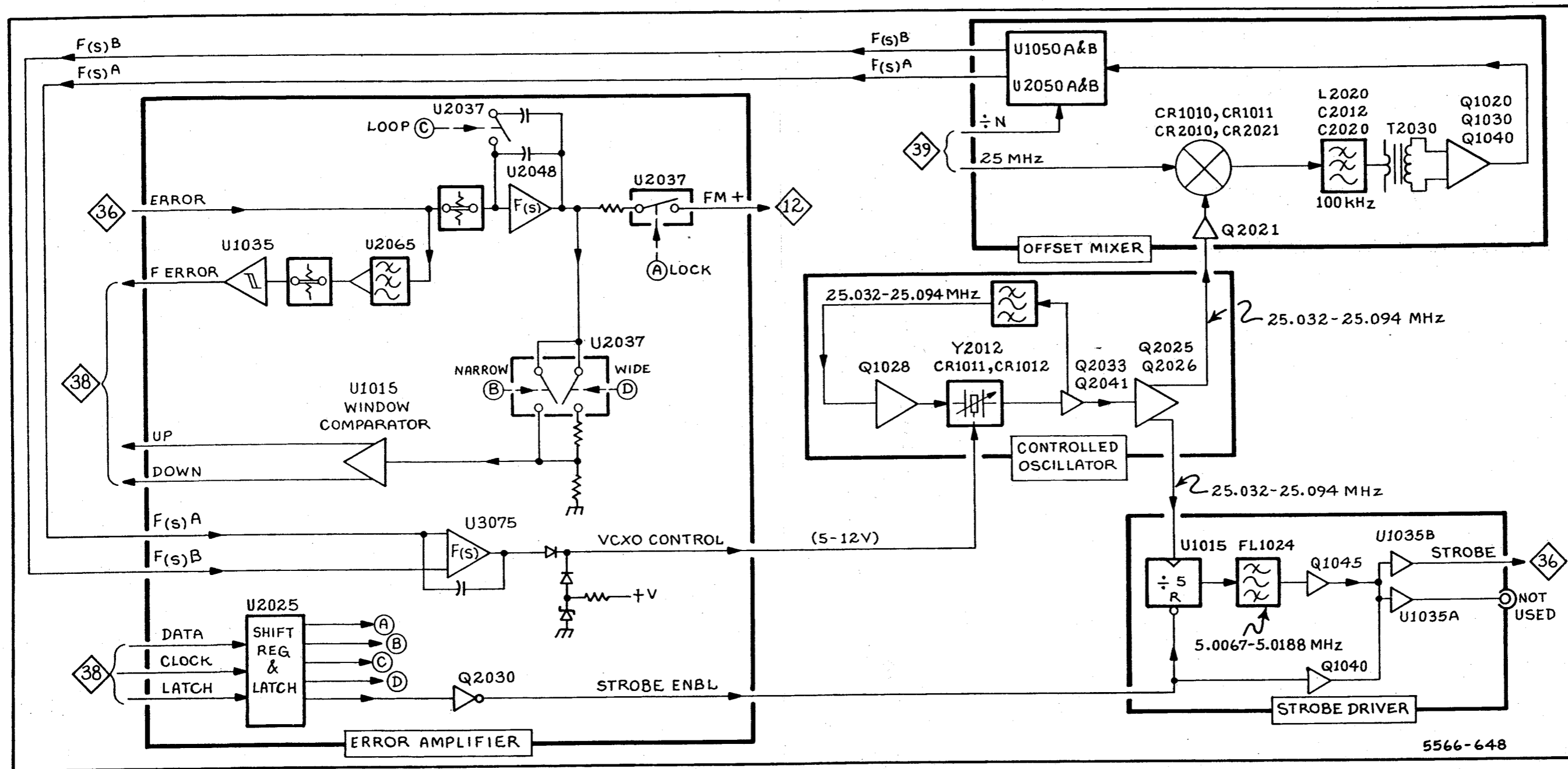

OFFSET MIXER & CONTROLLED OSC
STROBE DRIVER & ERROR AMPLIFIER

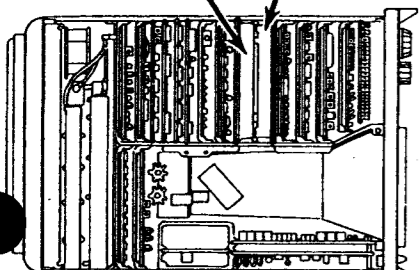

5566-649

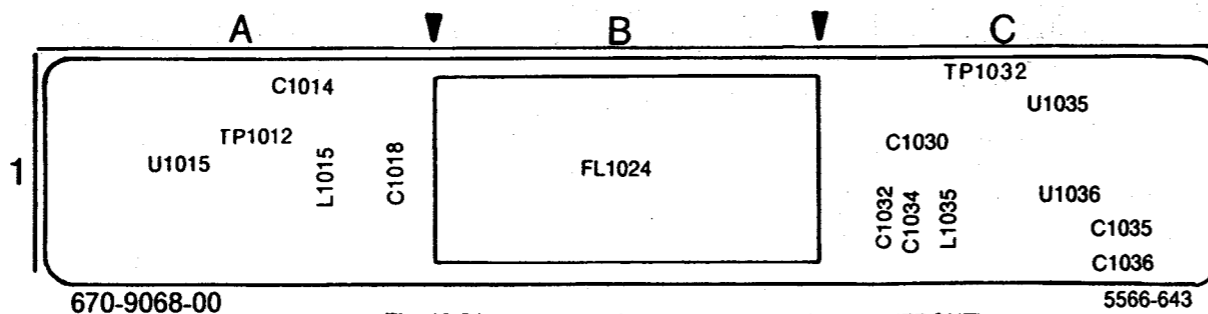

Fig. 10-51. A50A2—Strobe Driver circuit board (FRONT)

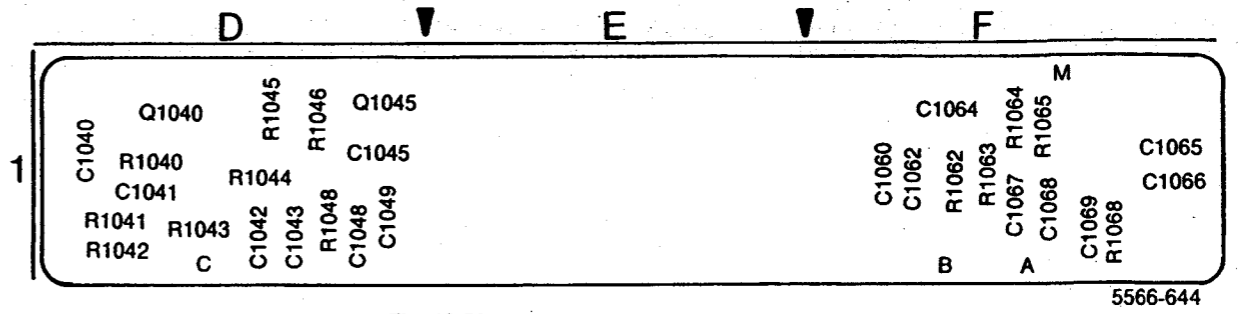
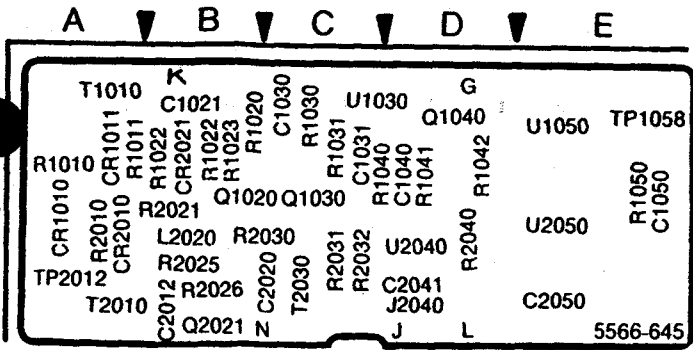
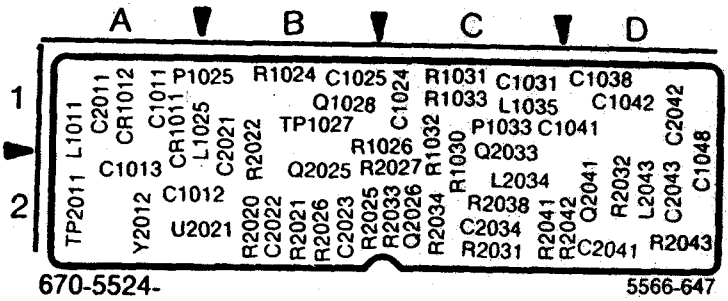

Fig. 10-52. A50A2—Strobe Driver circuit board. (REAR)



670-5522- Fig. 10-53. A50A3—Offset Mixer circuit board.



670-5524- Fig. 10-55. A50A5—Controlled Oscillator circuit board.

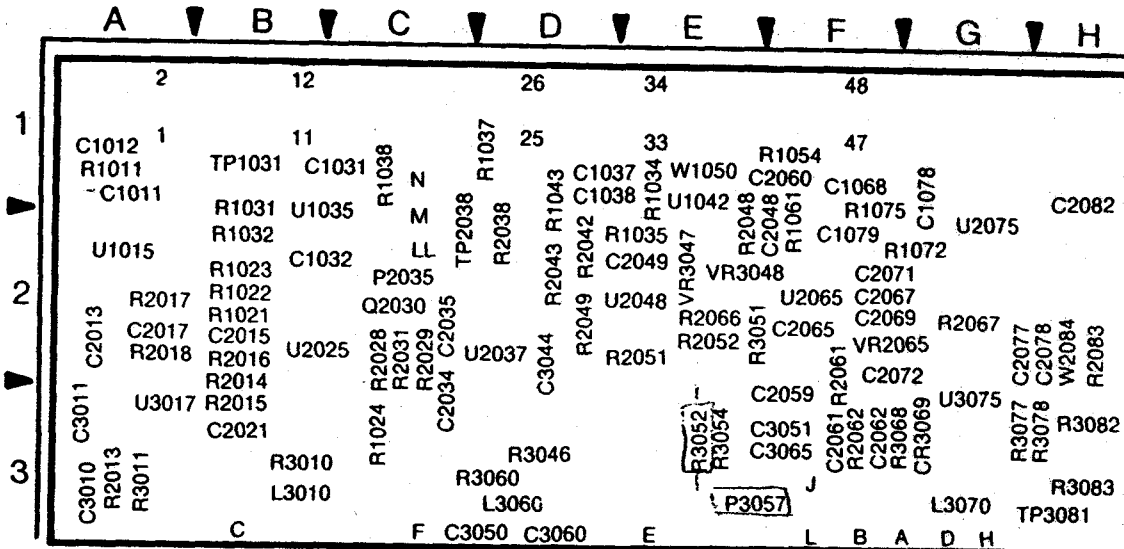

670-7921- Fig. 10-54. A50A4—Error Amplifier circuit board.

ASSEMBLY A50A5

CIRCUIT NUMBER	SCHEM LOCATION	BOARD LOCATION	CIRCUIT NUMBER	SCHEM LOCATION	BOARD LOCATION	CIRCUIT NUMBER	SCHEM LOCATION	BOARD LOCATION
C1011	D2	A1	L1011	D2	A1	R2021	E2	B2
C1012	D2	A2	L1025	D2	B1	R2022	D2	B1
C1013	D3	A2	L1035	C1	C1	R2025	E2	B2
C1024	D1	C1	L2034	D1	C2	R2026	E2	B2
C1025	C1	B1	L2043	D1	D2	R2027	E2	C2
C1031	C1	C1				R2031	C1	C2
C1038	D1	D1	P1025	D2	B1	R2032	D1	D2
C1041	D1	D1	P1033	C1	C1	R2033	E2	C2
C1042	D1	D1				R2034	D2	C2
C1048	D1	D1	Q1028	C1	B1	R2038	D1	C2
C2011	D2	A1	Q2025	E2	B2	R2041	D1	C2
C2021	C2	B1	Q2026	E1	C2	R2042	D1	D2
C2022	C2	B2	Q2033	D2	C1	R2043	D1	D2
C2023	E2	B2	Q2041	D1	D2			
C2034	D2	C2				TP1027	C2	B1
C2041	D1	D2	R1024	D2	B1	TP2011	E2	A2
C2042	D1	D1	R1026	C1	C1			
C2043	D1	D2	R1030	C1	C2	U2021	C2	B2
			R1031	C1	C1			
CR1011	D2	A1	R1032	C1	C1	Y2012	D2	A2
CR1012	D2	A1	R1033	C1	C1			
			R2020	C2	B1			

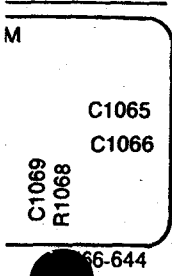

66-644

PHASE LOCK SYNTHESIZER (PHASE LOCK)



ASSEMBLY A50A2

CIRCUIT NUMBER	SCHEM LOCATION	BOARD LOCATION	CIRCUIT NUMBER	SCHEM LOCATION	BOARD LOCATION	CIRCUIT NUMBER	SCHEM LOCATION	BOARD LOCATION	CIRCUIT NUMBER	SCHEM LOCATION	BOARD LOCATION
C1014	E3	A1	C1048	F4	D1	L1035	E4	C1	R1048	E4	D1
C1016	E3	A1	C1049	F4	D1				R1062	E3	F1
C1018	E4	A1	C1060	E4	F1	Q1040	F4	D1	R1063	E3	F1
C1030	E3	C1	C1062	E4	F1	Q1045	F3	D1	R1064	E3	F1
C1032	E3	C1	C1064	E3	F1				R1065	E3	F1
C1034	E3	C1	C1065	D3	F1	R1040	E4	D1	R1066	E3	F1
C1035	E4	C1	C1066	D3	F1	R1041	E4	D1			
C1036	E4	C1	C1067	E3	F1	R1041	F3	D1	TP1012	E3	A1
C1040	F3	D1	C1068	E3	F1	R1042	F3	D1	TP1032	F3	C1
C1041	E4	D1	C1069	D3	F1	R1043	D4	D1			
C1042	D4	D1				R1044	E3	D1	U1015	E3	A1
C1043	D4	D1	FL1024	E3	B1	R1045	F4	D1	U1035A	F3	C1
C1045	E3	D1				R1046	F3	D1	U1035	F3	C1
			L1015	E4	A1				U1036	D4	C1

ASSEMBLY A50A4

CIRCUIT NUMBER	SCHEM LOCATION	BOARD LOCATION	CIRCUIT NUMBER	SCHEM LOCATION	BOARD LOCATION	CIRCUIT NUMBER	SCHEM LOCATION	BOARD LOCATION	CIRCUIT NUMBER	SCHEM LOCATION	BOARD LOCATION
C1011	D4	A1	C3011	C5	A3	R1061	B4	F2	R3060	A5	D3
C1012	C4	A1	C3044	C3	D2	R1072	A5	G2	R3068	D2	G3
C1031	B5	C1	C3050	B5	D3	R1075	B5	F1	R3077	C2	G3
C1032	A3	B2	C3051	B4	F3	R2013	D4	A3	R3078	C2	H3
C1037	A5	D1	C3060	B5	D3	R2014	C4	B2	R3082	A4	H3
C1038	C3	D1	C3065	B4	F3	R2015	C4	B3	R3083	A4	H3
C1068	A5	F1				R2016	C4	B2			
C1078	A5	G1	CR3069	D2	G3	R2017	C4	A2	TP1031	D5	B1
C1079	B5	F2				R2018	C4	A2	TP2038	B3	C2
C2013	D4	A2	L3010	C5	B3	R2028	D3	C2	TP3081	A4	H3
C2015	C4	B2	L3060	B5	D3	R2029	B4	C2			
C2017	C4	A2	L3070	B5	G3	R2031	D3	C2	U1015	D4	A2
C2021	C5	B3				R2038	B3	D2	U1035	D5	B2
C2034	B3	C3	P2035	C4	C2	R2042	C3	D2	U1042	A4	E1
C2035	B4	C2	P3057	D3	E3	R2043	C3	D2	U2025	A3	B2
C2048	C5	E2				R2048	C5	E2	U2037	B3	D2
C2049	E5	E2	Q2030	D3	C2	R2049	D3	D2	U2048	D3	E2
C2059	B4	F3				R2051	C3	E2	U2048	D5	E2
C2060	A5	F1	R1011	C4	A1	R2052	B4	E2	U2065	B4	F2
C2061	C2	F3	R1021	A4	B2	R2061	C2	F2	U2065	E5	F2
C2062	D2	F3	R1022	A3	B2	R2062	C2	F3	U2075	B5	G2
C2065	E5	F2	R1023	A3	B2	R2066	B4	E2	U3017	C5	A3
C2067	A4	F2	R1024	B3	C3	R2067	C2	G2	U3075	C2	G3
C2069	B5	F2	R1031	D5	B2	R2083	A4	H2	U3075	D5	G3
C2071	D5	F2	R1032	D5	B2	R3010	C5	B3			
C2072	C3	F2	R1034	C3	E1	R3011	A3	A3	VR2065	D3	F2
C2077	C2	H2	R1035	A4	E2	R3046	A3	D3	VR3047	C3	E2
C2078	C2	H2	R1037	B5	D1	R3051	B4	E2	VR3048	C3	E2
C2082	B5	H1	R1038	D5	C1	R3052	B4	E3			
C3010	C5	A3	R1043	C3	D1	R3054	B4	E3	W1050	A5	E1
			R1054	A5	F1				W2084	A4	H2

ASSEMBLY A50A3

CIRCUIT NUMBER	SCHEM LOCATION	BOARD LOCATION	CIRCUIT NUMBER	SCHEM LOCATION	BOARD LOCATION	CIRCUIT NUMBER	SCHEM LOCATION	BOARD LOCATION	CIRCUIT NUMBER	SCHEM LOCATION	BOARD LOCATION
C1021	B1	B1	L2020	B1	B2	R1040	B1	C1	T2010	B1	A2
C1030	A2	C1				R1041	A2	D1	T2030	B1	C2
C1031	B1	C1	Q1020	B2	B1	R1042	A1	D1			
C1040	A3	D1	Q1030	B1	C1	R1050	B2	E1	TP1058	A2	E1
C1050	A3	E1	Q1040	A2	D1	R2010	A1	A2	TP2012	B1	A2
C2012	A1	B2	Q2021	B1	B2	R2021	A1	B1			
C2020	A1	C2				R2025	B1	B2	U1030	A2	C1
C2041	B1	D2	R1010	A1	A1	R2026	B1	B2	U1050A	B2	E1
C2050	B3	E2	R1011	A1	A1	R2030	B1	B2	U1050B	B2	E1
			R1020	B2	B1	R2031	B1	C2	U2040	A2	D2
CR1010	A1	A2	R1022	B1	B1	R2032	B1	C2	U2050A	B2	E2
CR1011	A1	A1	R1023	B1	B1	R2040	B2	D2	U2050B	B2	E2
CR2010	A1	A2	R1030	B1	C1				U2050	B2	E2
CR2021	A1	B1	R1031	B1	C1	T1010	A1	A1			

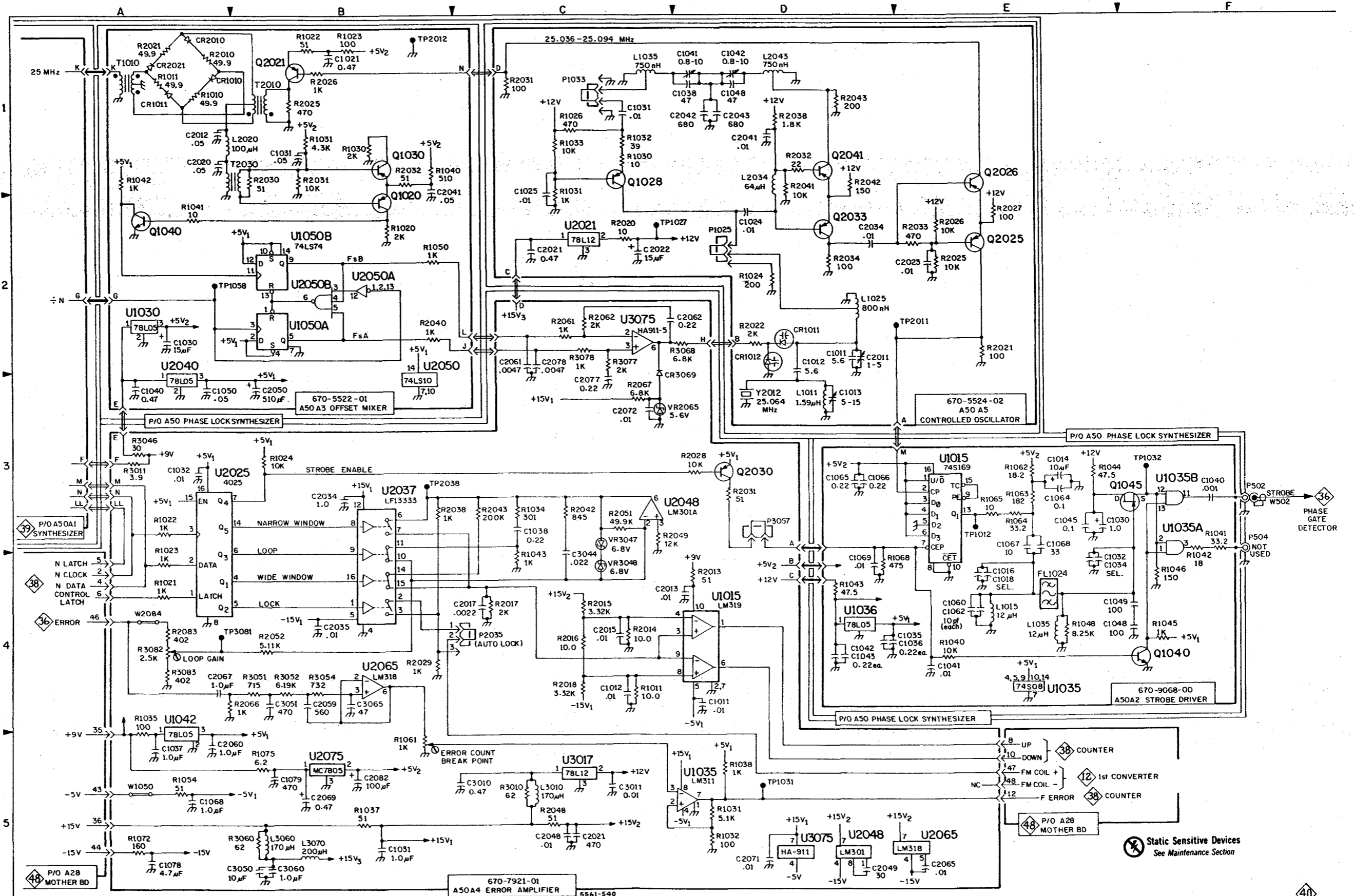

494A/494 AP

670-7921-01
A50A4 ERROR AMPLIFIER
5561-540

PHASE LOCK SYNTHESIZER

(OFFSET MIXER, ERROR AMPL., CONT. OSC., STROBE DRIVER)

Static Sensitive Devices
See Maintenance Section

40

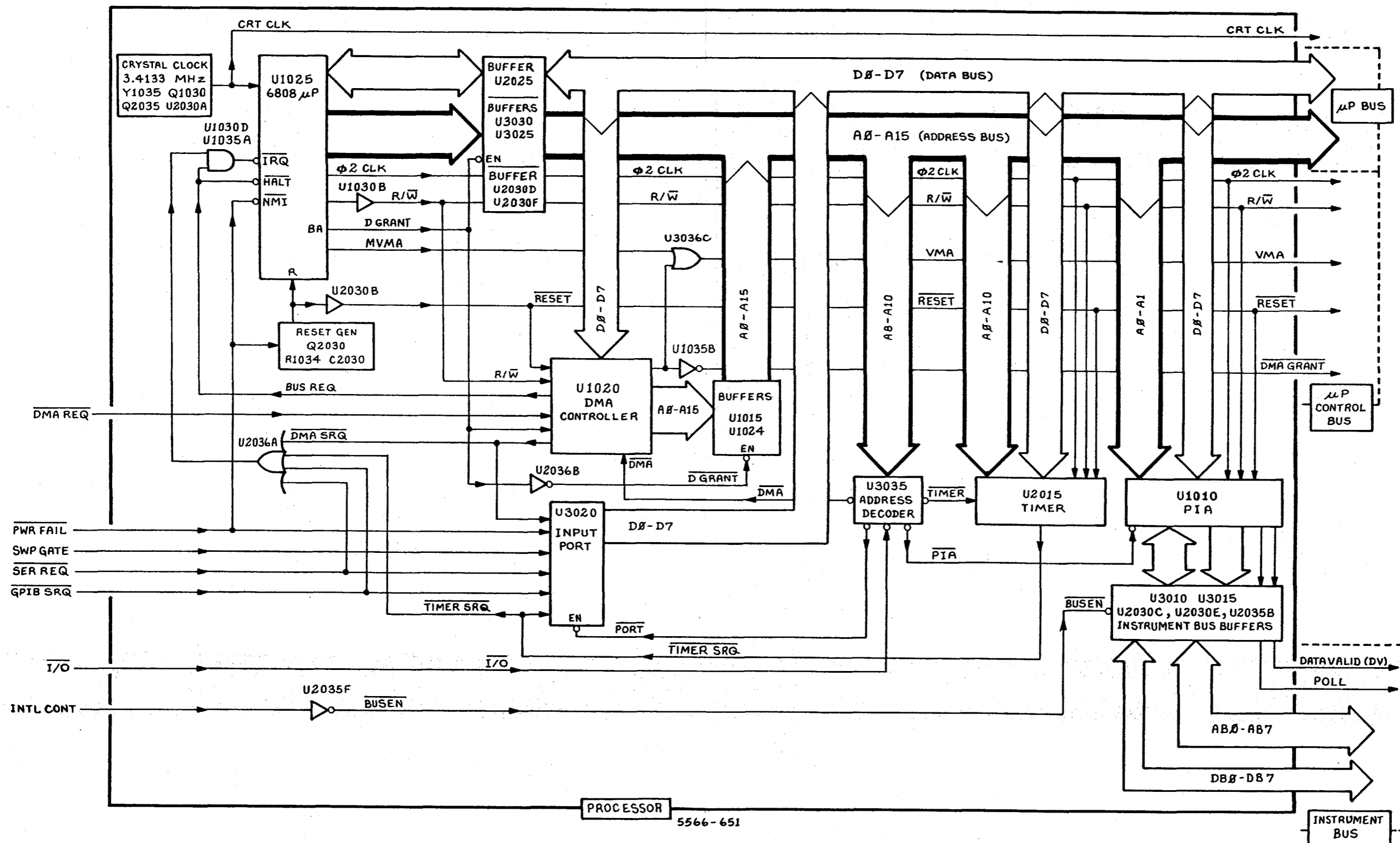

PROCESSOR



ASSEMBLY A58

CIRCUIT NUMBER	SCHEM LOCATION	BOARD LOCATION	CIRCUIT NUMBER	SCHEM LOCATION	BOARD LOCATION	CIRCUIT NUMBER	SCHEM LOCATION	BOARD LOCATION	CIRCUIT NUMBER	SCHEM LOCATION	BOARD LOCATION
C1015	E2	A1	R1010	B3	A1	R3034	D1	C2			
C1016	F1	A1	R1021	C1	C1	R3035	A1	C2			
C1017	D4	A1	R1022	C1	C2	R3036	A1	C3	U2030E	F5	C2
C1025	C3	B1	R1023	C1	C2	R3037	F1	C3	U2030F	B3	C2
C1026	E1	B2	R1024	C1	C2						
C1027	B1	C1	R1025	B2	C2	TP1015	A4	A1			
C1028	D3	B1	R1026	C3	C1				U2030G	E3	C2
C1031	D5	C1	R1030	F2	C1						
C1032	E5	C1	R1031	A4	C1				U2030	F5	C2
C1033	A1	C1	R1032	A1	C1				U2035A	E2	C2
C1034	F5	C2	R1033	A1	C2				U2035B	E2	C2
C1035	E2	C1	R1034	B2	C2	U1010	E2	A2	U2035C	E2	C2
C1036	A1	C1	R1035	A1	C2	U1015	D4	A1	U2035D	B2	C2
C2015	E4	A3	R1036	B1	C2				U2035E	A2	C2
C2030	B2	C2	R1037	B1	C2				U2035F	F2	C2
C2031	E5	C2	R1038	A4	C1	U1020	D3	B2	U2035	F5	C2
C2032	F5	C2	R2020	C1	B2	U1024	D3	B1	U2036B	D3	C2
C2033	F2	C2	R2021	C1	C2	U1025	B1	B2	U2036A	A2	C2
C2034	A1	C2	R2022	C1	C2						
C2035	A1	C2	R2023	C1	C2						
C2036	E5	C2	R2024	B1	C2				U2036	F5	C2
C3015	E2	A3	R2025	A2	C2	U1030A	C3	C1	U3010	E2	A3
C3020	C3	C2	R2030	F2	C2	U1030B	B3	C1			
C3025	C2	B3	R2031	E2	C2	U1030C	C3	C1	U3015	E4	A3
C3030	D2	G3	R2032	A1	C2	U1030D	B2	C1	U3020	C5	B3
C3034	B4	C3	R2033	E3	C2	U1030	E5	C1			
C3035	A1	C3	R2034	B2	C2	U1035A	B2	C1			
C3036	A3	C3	R2035	F2	C2	U1035B	A4	C1			
			R2036	A1	C2	U1035C	B4	C1	U3025	C3	B3
CR1030	B1	C1	R2037	A1	C2	U1035D	B3	C1			
CR2020	C1	B2	R2038	F4	C2	U1035	E5	C1			
CR2025	C1	B2	R2039	A1	C2				U3030	D2	C3
			R2045	D3	C2				U3035	B4	C3
L1035	F5	C1	R3010	F3	A3						
L3035	A2	C3	R3011	F3	A3						
			R3012	F3	A3	U2015	F1	A2			
P1035	A4	C1	R3013	F3	A3	U2025	A4	B2	U3036A	D1	C3
P1035	A4	C1	R3014	F3	A3	U2025	E1	B2	U3036B	B3	C3
P3010	F2	A3	R3015	F3	A3	U2030A	B1	C2	U3036C	A3	C3
P3015	D1	A3	R3016	F3	A3	U2030B	B1	C2	U3036	E5	C3
			R3017	F3	A3						
Q1030	B1	C1	R3030	A2	C2				W2035	A2	C2
Q2030	B2	C2	R3031	B2	C2						
Q2035	A1	C2	R3032	E2	C3	U2030C	F2	C2	Y1030	A1	C1
			R3033	A2	C2	U2030D	C2	C2			

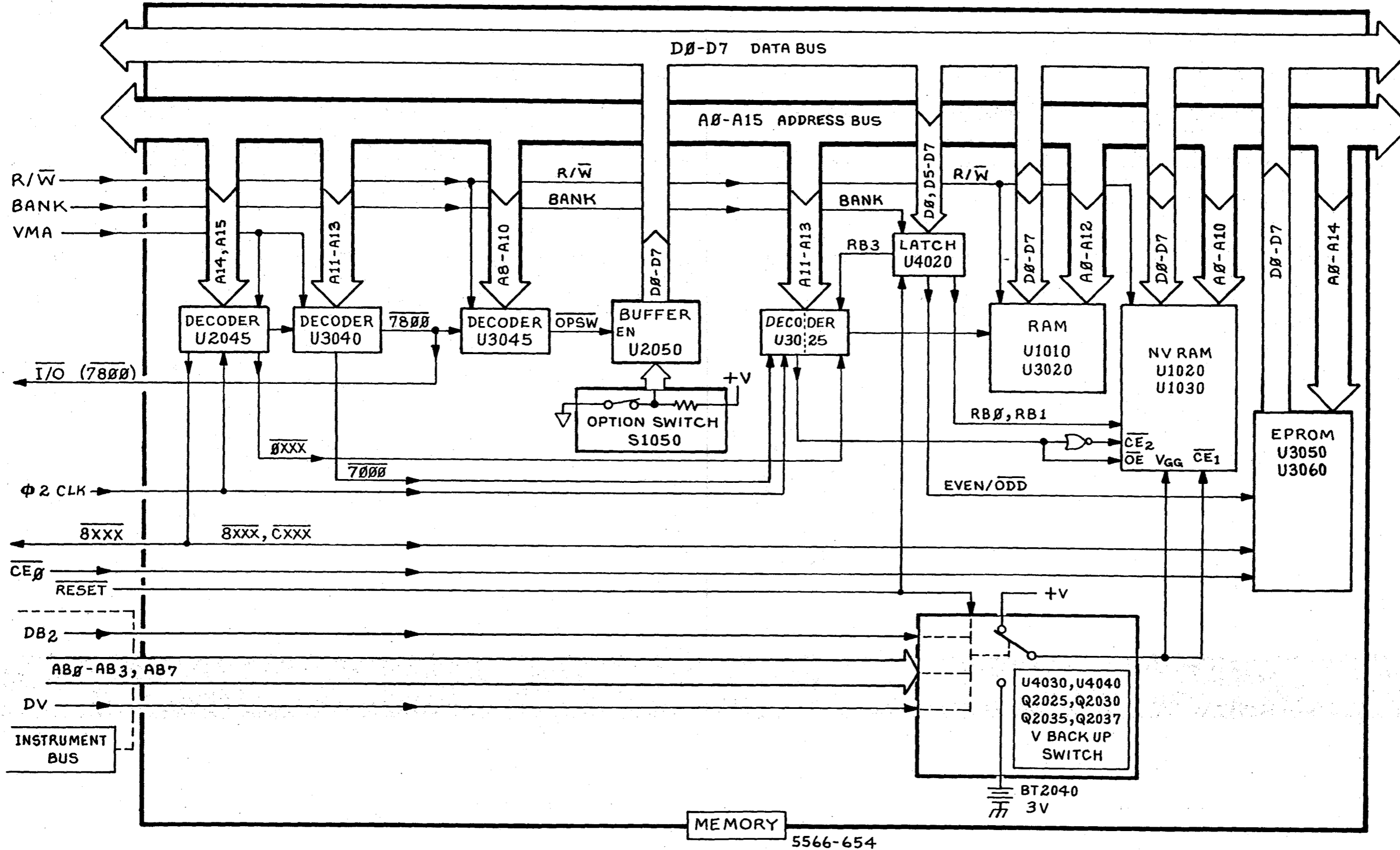

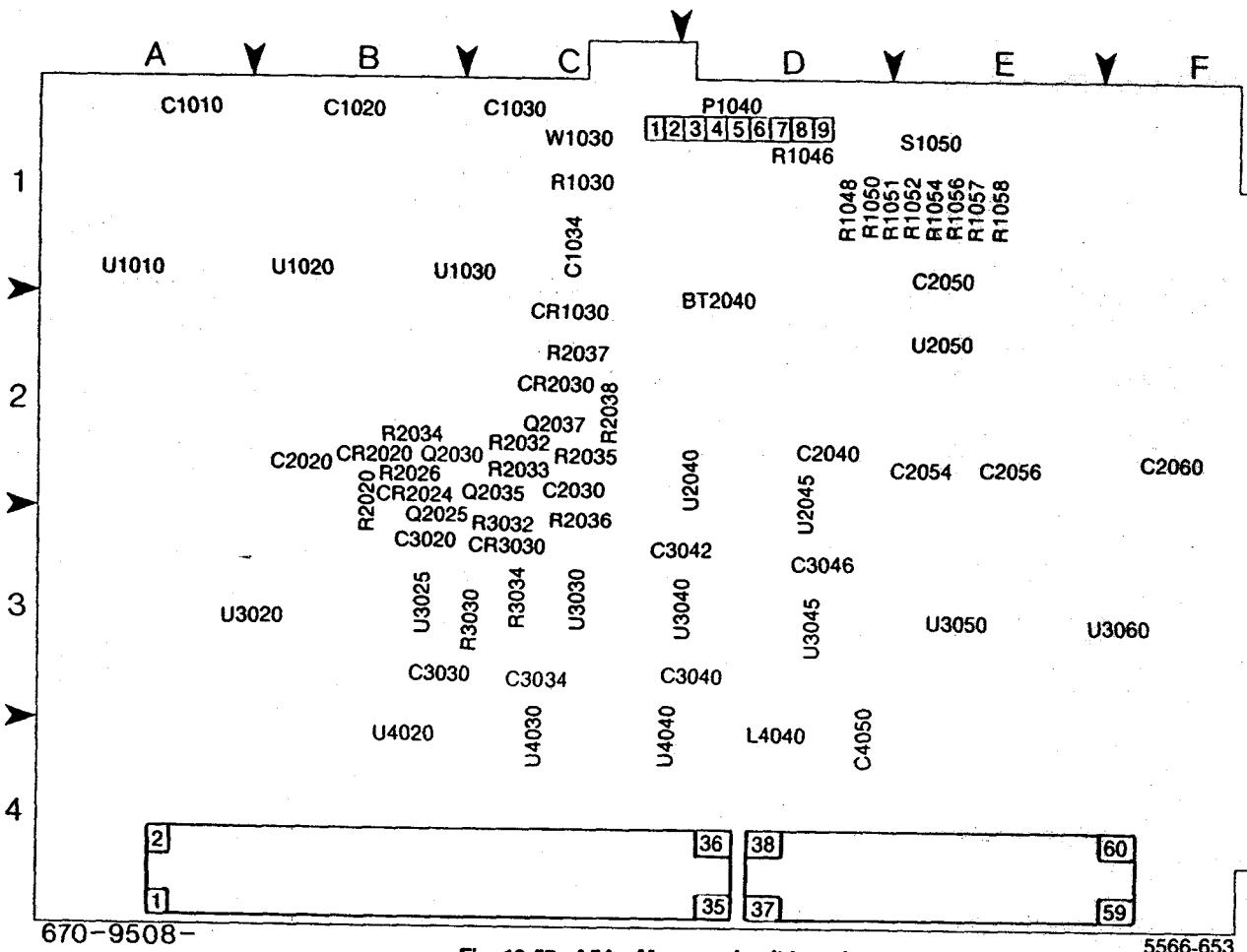

 Static Sensitive Devices
See Maintenance Section

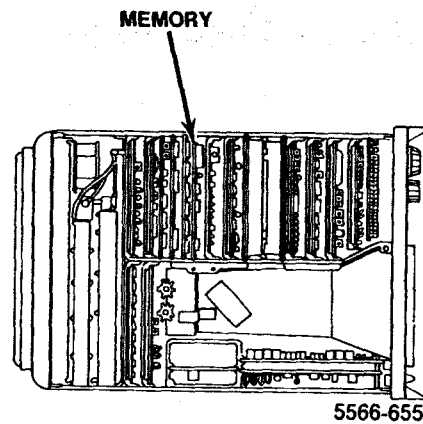

 St

MEMORY



ASSEMBLY A54

CIRCUIT NUMBER	SCHEM LOCATION	BOARD LOCATION	CIRCUIT NUMBER	SCHEM LOCATION	BOARD LOCATION	CIRCUIT NUMBER	SCHEM LOCATION	BOARD LOCATION
BT02040	C4	D2	Q2025	B3	B3	U1020	D4	B1
C1010	E1	A1	Q2030	C3	B2	U1030	D2	B1
C1020	C4	B1	Q2035	C3	C2	U2040B	A1	D2
C1030	C2	C1	Q2037	C3	C2	U2040C	E1	D2
C1034	B4	C1	R1030	C4	C1	U2040D	E1	D2
C2020	D3	B2	R1046	F1	D1	U2040	F5	D2
C2030	B3	C2	R1048	D1	D1	U2045	A1	D3
C2040	A1	D2	R1050	D1	D1			
C2050	D1	E1	R1051	D1	D1	U2050	D1	E2
C2054	E1	E2	R1052	C1	E1	U3020	E3	B3
C2056	F1	E2	R1054	C1	E1	U3025	B2	B3
C2060	F3	F2	R1056	C1	E1	U3030A	C2	C3
C3020	B2	B3	R1057	C1	E1	U3030B	C3	C3
C3030	A2	B3	R1058	C1	E1	U3030C	B2	C3
C3034	A3	C3	R2020	B3	B2	U3030D	C2	C3
C3040	A3	C3	R2026	B3	B2	U3030	F5	C3
C3042	B1	C3	R2032	C3	C2	U3040	B1	C3
C3046	B1	D3	R2033	C3	C2	U3045	C1	D3
C4050	A3	D4	R2034	B3	B2	U3050	F1	E3
			R2035	B3	C2			
CR1030	B4	C2	R2036	C2	C3	U3060	F3	F3
CR2020	B3	B2	R2037	C4	C2	U4020	A2	B4
CR2024	B3	B2	R2038	C3	C2			
CR2030	C3	C2	R3030	B3	B3	U4030	B3	C4
CR3030	B3	C3	R3032	B3	C3	U4040	A3	C4
			R3034	C4	C3			
L4040	A3	D4	S1050	C1	E1	W1030	C4	C1
P1040	C3	D1	U1010	E2	A1			
P1040	F1	D1						

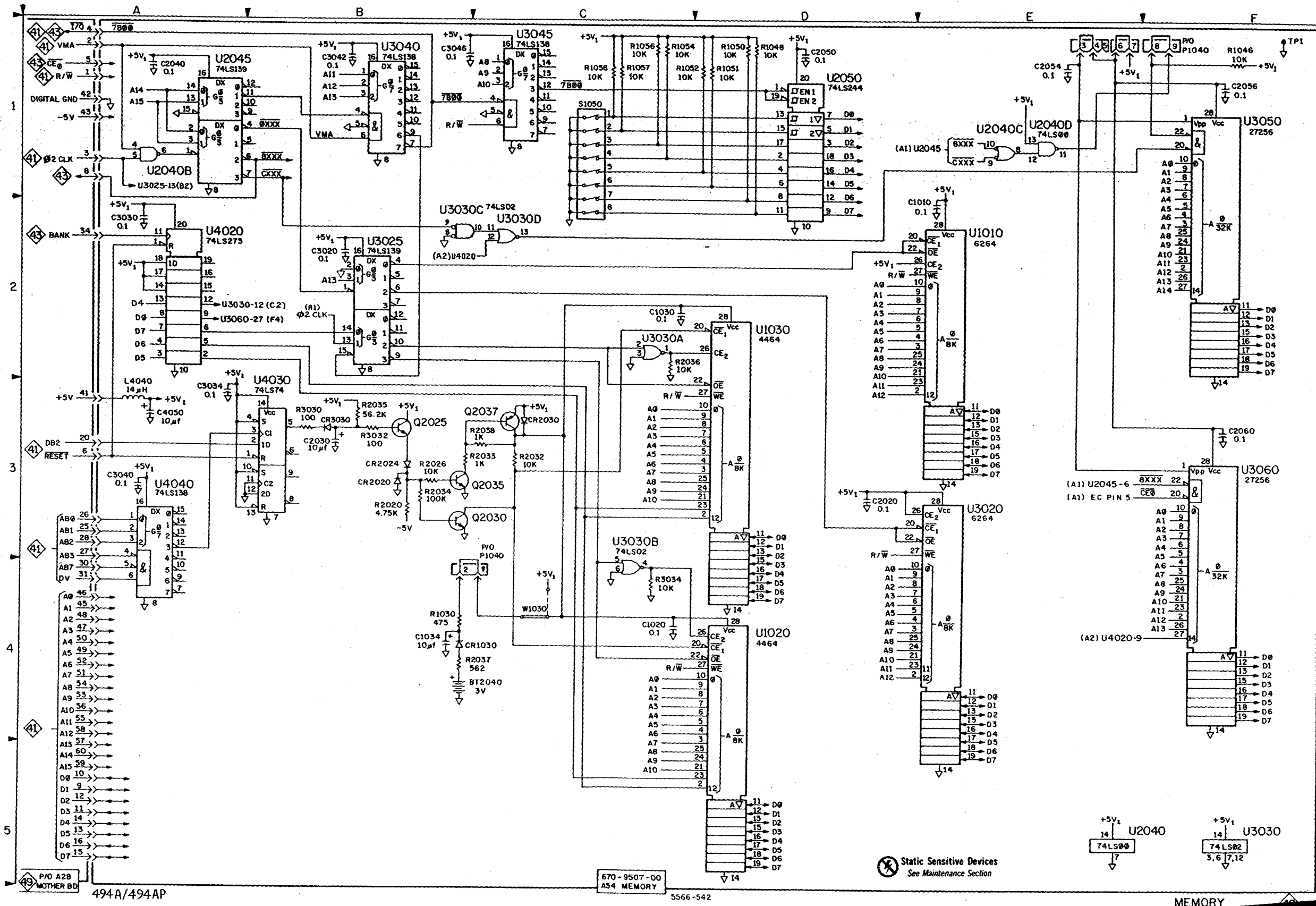

494A/494AP

670-9507-00
AS4 MEMORY
5566-542

Static Sensitive Devices
See Maintenance Section

+5V₁
U2040
74LS00

+5V₁
U3030
74LS02

MEMORY

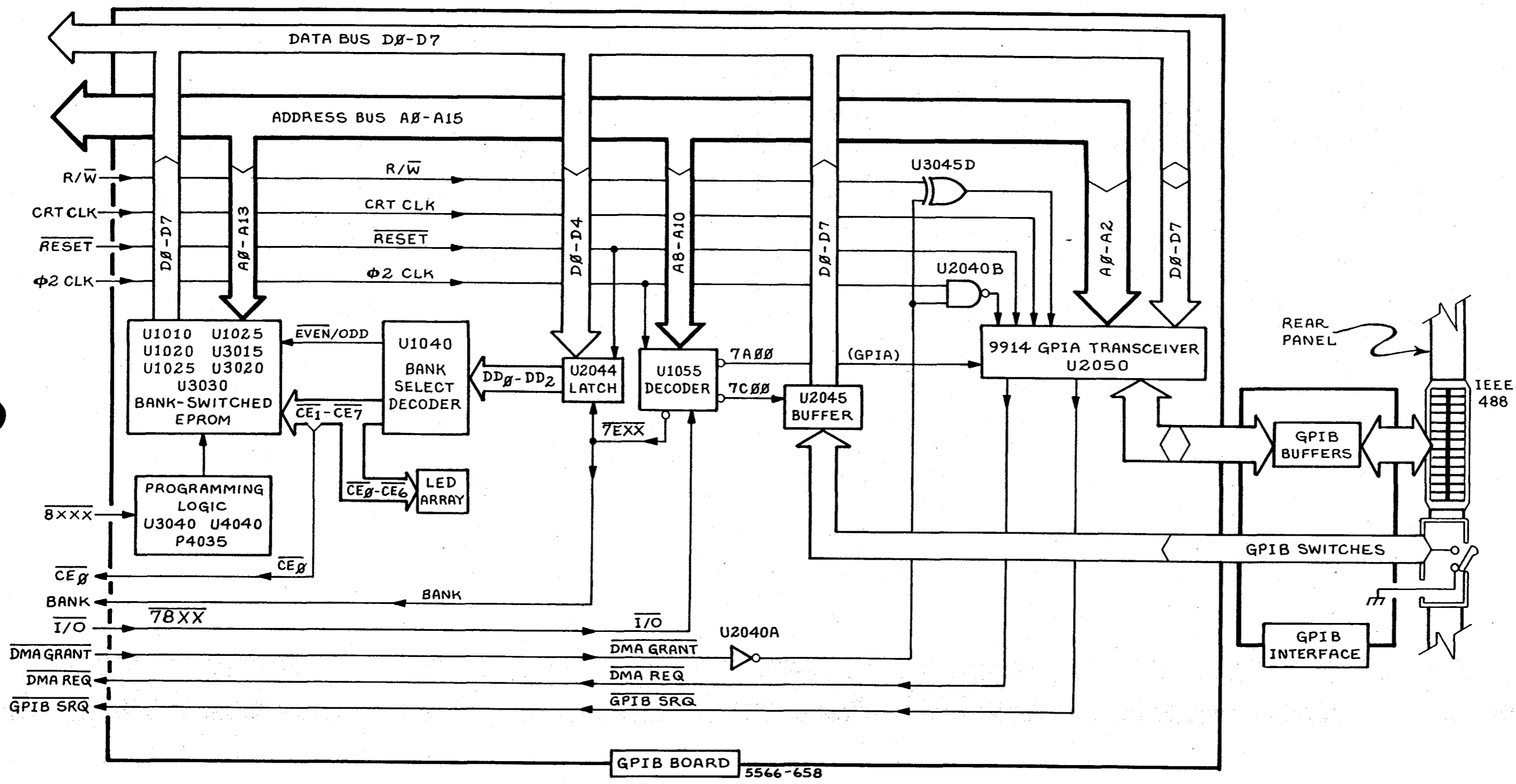

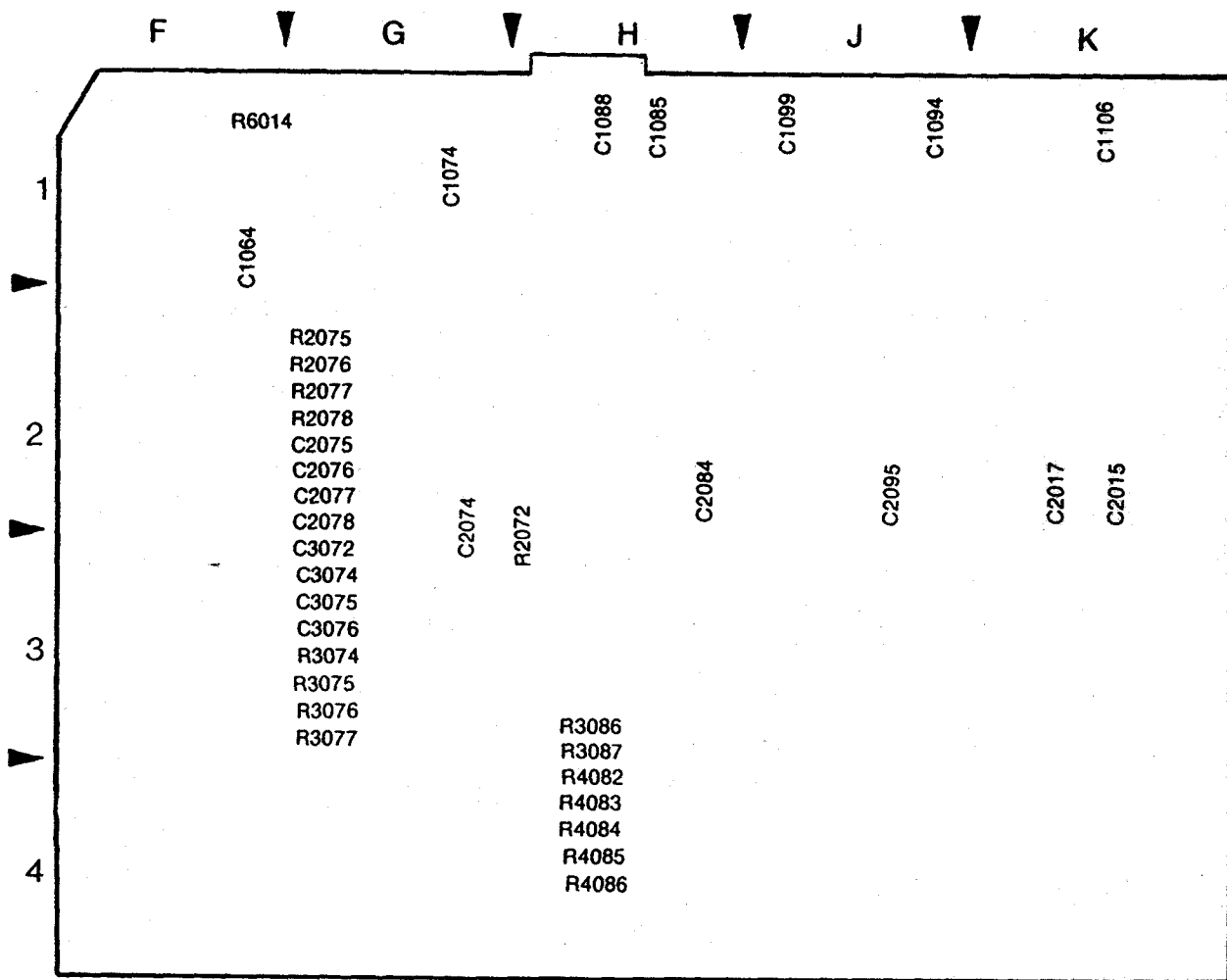

670-9770-00

Fig. 10-59. A56—GPIB circuit board. (REAR)

5561-572

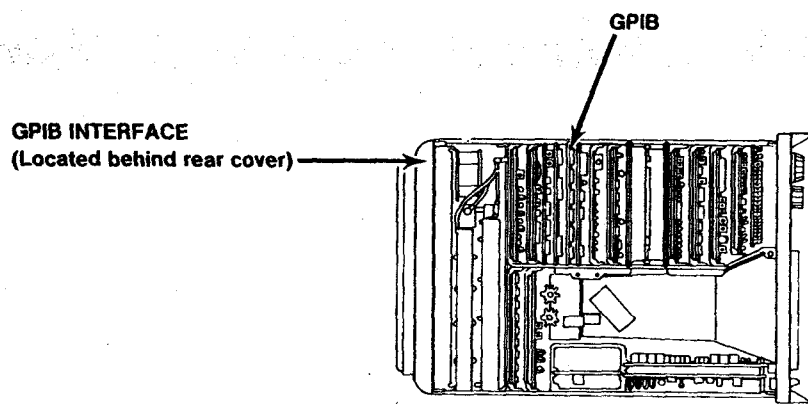

5566-659

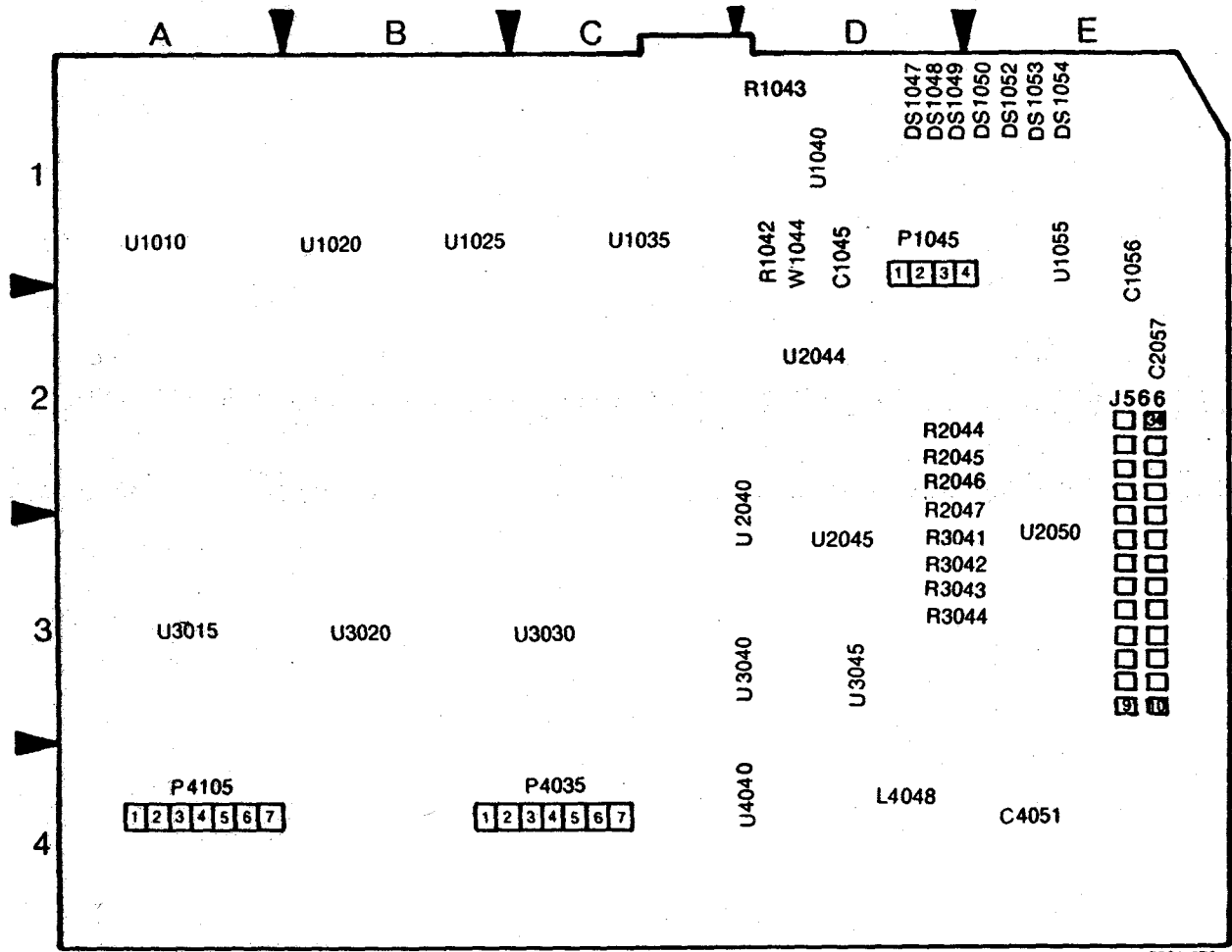

670-9770-00

5561-570

Fig. 10-58. A56—GPIB circuit board. (FRONT)

ROM BANKS & GPIB



ASSEMBLY A56

CIRCUIT NUMBER	SCHEM LOCATION	BOARD LOCATION	CIRCUIT NUMBER	SCHEM LOCATION	BOARD LOCATION	CIRCUIT NUMBER	SCHEM LOCATION	BOARD LOCATION	CIRCUIT NUMBER	SCHEM LOCATION	BOARD LOCATION
C1045	B2	D1	L4048	A3	D4	R3077	D4	G3	U3015	D1	A3
C1056	B3	E1	P1045	A5	D1	R3086	E2	H3	U3020	E1	B3
C1064	A2	F1	P4015	A1	A4	R3087	D2	H3	U3030	E1	C3
C1074	C3	G1	P4015	B2	A4	R4082	C2	H3	U3040A	B2	C3
C1085	A1	H1	P4015	B2	A4	R4083	C2	H4	U3040B	A2	C3
C1088	C1	H1	P4035	A2	C4	R4084	B2	H4	U3040C	B2	C3
C1094	B1	J1	P4035	B2	C4	R4085	A2	H4	U3040D	C2	C3
C1099	C1	J1	P4035	B2	C4	R4086	B2	H4	U3040E	C4	C3
C1106	B1	K1	P4035	B2	C4	R6014	C2	F1	U3045B	C4	D3
C2015	A1	K2	P4035	C2	C4	U1010	B1	A1	U3045A	B5	D3
C2017	D1	K2	P4035	C2	C4	U1020	B1	B1	U4040A	D2	C4
C2057	B3	E2	P4035	D2	C4	U1025	C1	B1	U4040B	E2	C4
C2074	C4	G2	P4035	E2	C4	U1035	C1	C1	U4040C	A2	C4
C2075	D4	G2				U1040	C3	D1	U4040D	C2	C4
C2076	D4	G2	R1042	B3	D1	U1055	A3	E1	U4040E	C4	C4
C2077	E4	G2	R1043	C3	D1	U2040	B3	D2			
C2078	E4	G2	R1043	C3	D1	U2044	B3	D2			
C2084	E1	H2	R2044	E5	D2	U2045	D4	D3			
C2095	E1	J2	R2045	E5	D2	U2050	B3	E3			
C3072	D4	G3	R2046	E5	D2						
C3074	D4	G3	R2047	E5	D2						
C3075	D4	G3	R2072	A5	H2						
C3076	D4	G3	R2075	E4	G2						
C4051	A4	E4	R2076	D4	G2						
DS1047	C3	D1	R2077	D4	G2						
DS1048	C3	D1	R2078	D4	G2						
DS1049	C3	D1	R3041	E5	D3						
DS1050	C3	E1	R3042	E5	D3						
DS1052	D3	E1	R3043	E5	D3						
DS1053	D3	E1	R3044	E5	D3						
DS1054	D3	E1	R3074	D4	G3						
			R3075	D4	G3						
			R3076	D4	G3						

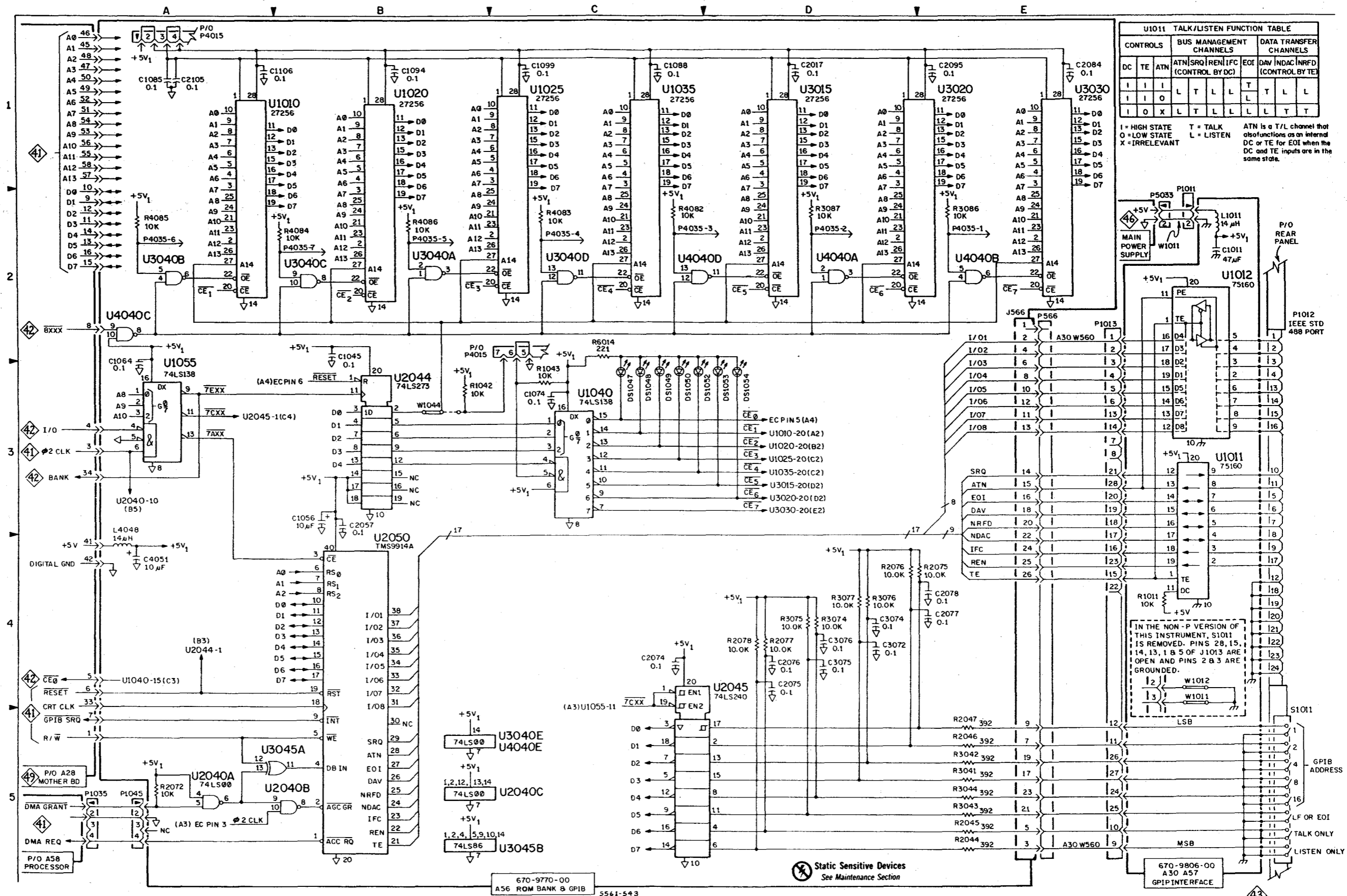

CONTROLS			BUS MANAGEMENT CHANNELS				DATA TRANSFER CHANNELS				
DC	TE	ATN	ATN	SRQ	REN	IFC	EOI	DAV	NDAC	NRFD	IFC
			(CONTROL BY DC)				(CONTROL BY TE)				
I	I	I	L	T	L	L	L	T	L	L	L
I	I	O	X	L	T	L	L	L	L	T	T

I = HIGH STATE
O = LOW STATE
X = IRRELEVANT

T = TALK
L = LISTEN

ATN is a T/L channel that also functions as an internal DC or TE for EOI when the DC and TE inputs are in the same state.

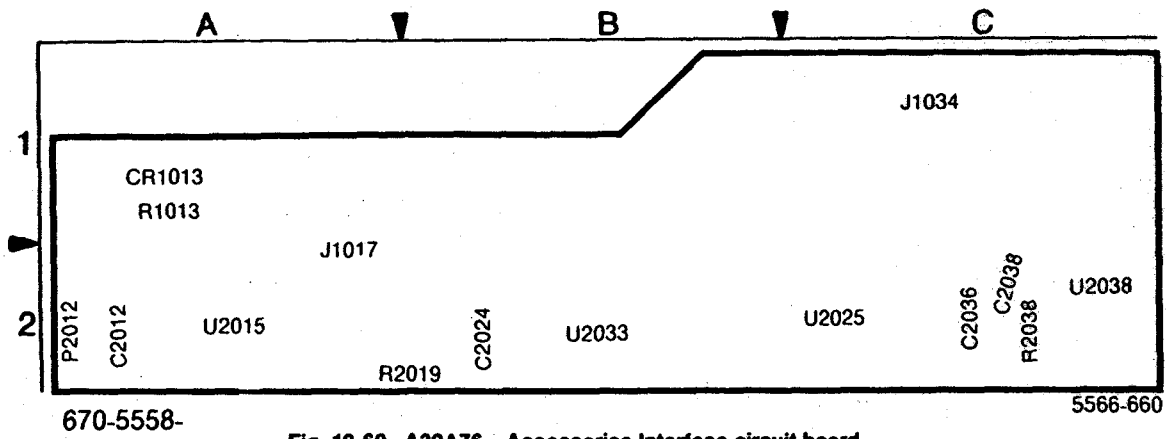
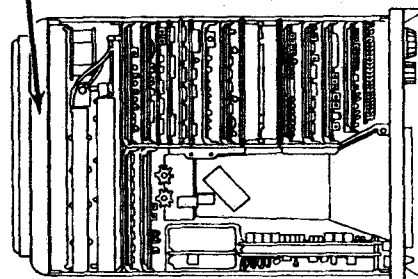

Fig. 10-60. A30A76—Accessories Interface circuit board.

ACCESSORIES INTERFACE
(Located behind rear cover)



5566-661

ACCESSORIES INTERFACE



ASSEMBLY A30A76

CIRCUIT NUMBER	SCHEM LOCATION	BOARD LOCATION	CIRCUIT NUMBER	SCHEM LOCATION	BOARD LOCATION
C2012	B1	A2	R1013	A1	A1
C2024	B2	B2	R2019	C3	B2
C2036	B2	C2	R2038	B1	C2
C2038	A2	C2			
CR1013	A1	A1	U2015	B1	A2
			U2025	C3	C2
J1017	C1	A2	U2033	B2	B2
J1034	A1	C1	U2038B	B3	C2
			U2038	B2	C2
P2012	A3	A2			

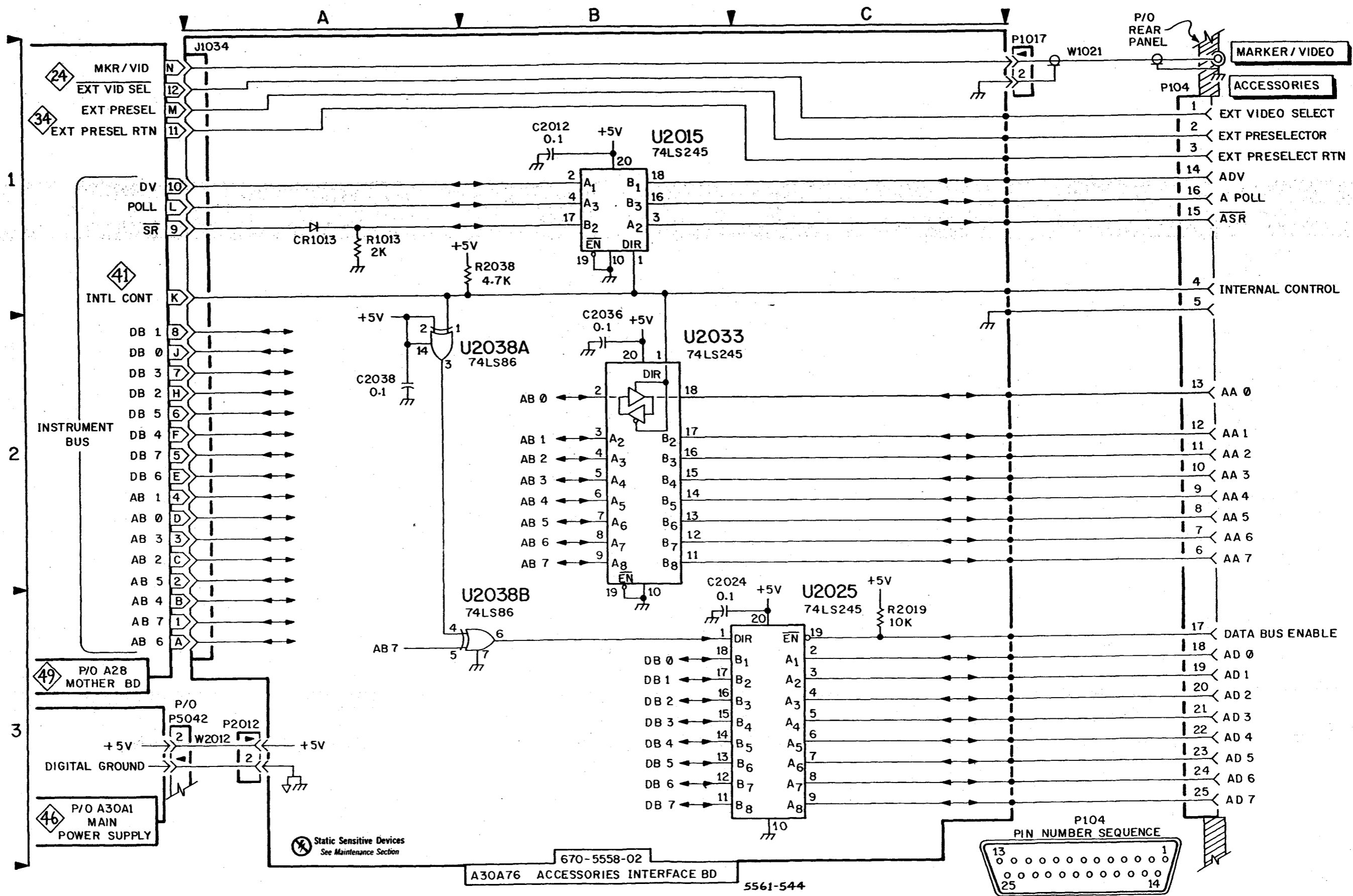

494A/494AP

ACCESSORIES INTERFACE

44

670-5558-02
A30A76 ACCESSORIES INTERFACE BD

5561-544

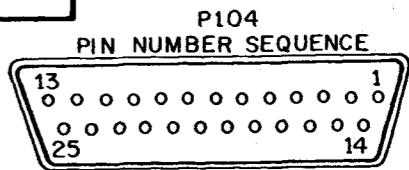

Static Sensitive Devices
See Maintenance Section

49 P/O A28 MOTHER BD

46 P/O A30A1 MAIN POWER SUPPLY

MARKER / VIDEO

ACCESSORIES

P/O REAR PANEL

DATA BUS ENABLE

AD 0
AD 1
AD 2
AD 3
AD 4
AD 5
AD 6
AD 7

AA 0
AA 1
AA 2
AA 3
AA 4
AA 5
AA 6
AA 7

INTERNAL CONTROL

ASR

A POLL

ADV

EXT PRESELECT RTN

EXT PRESELECTOR

EXT VIDEO SELECT

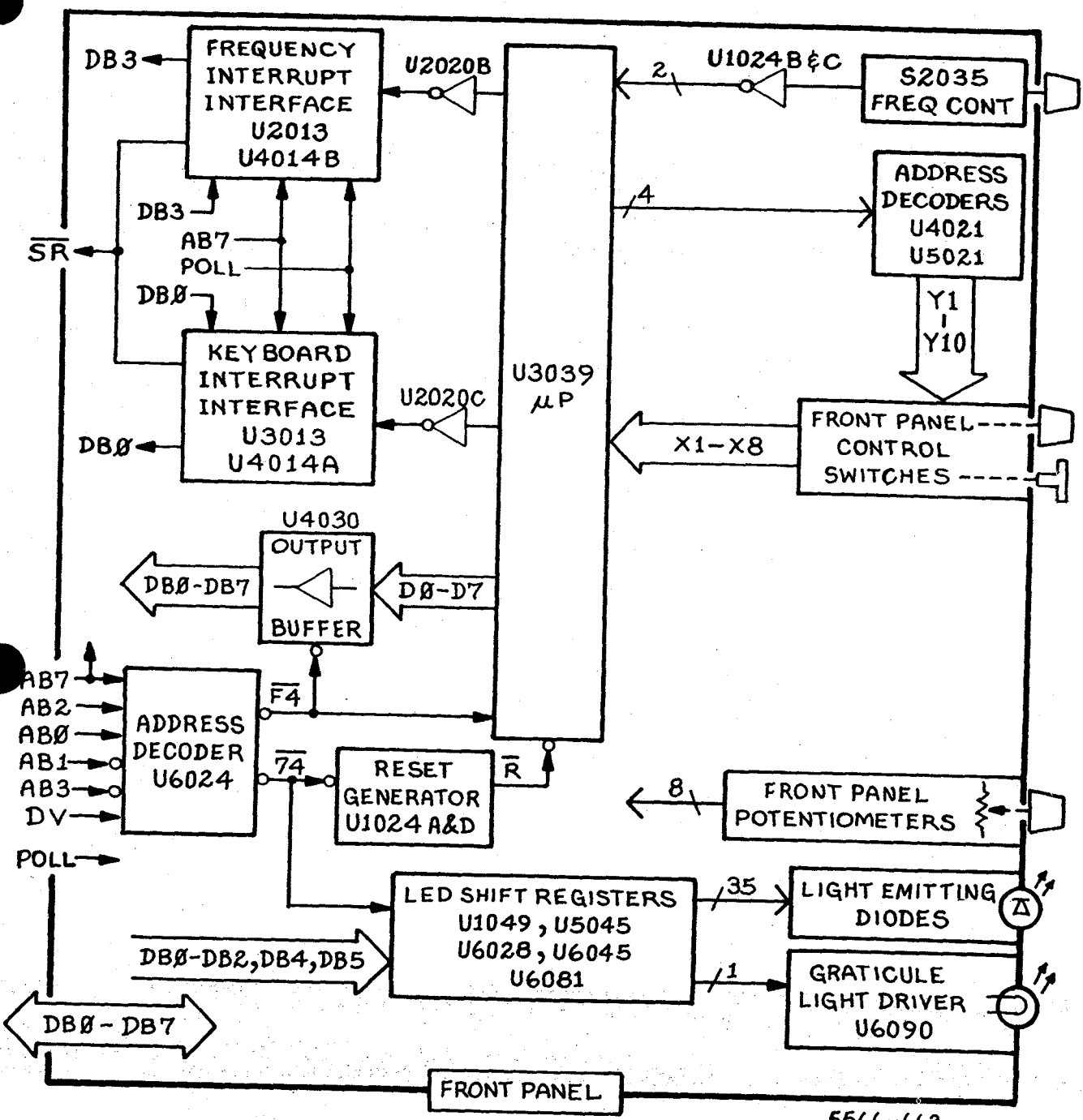

5566-663

1
2
3
4
5
6

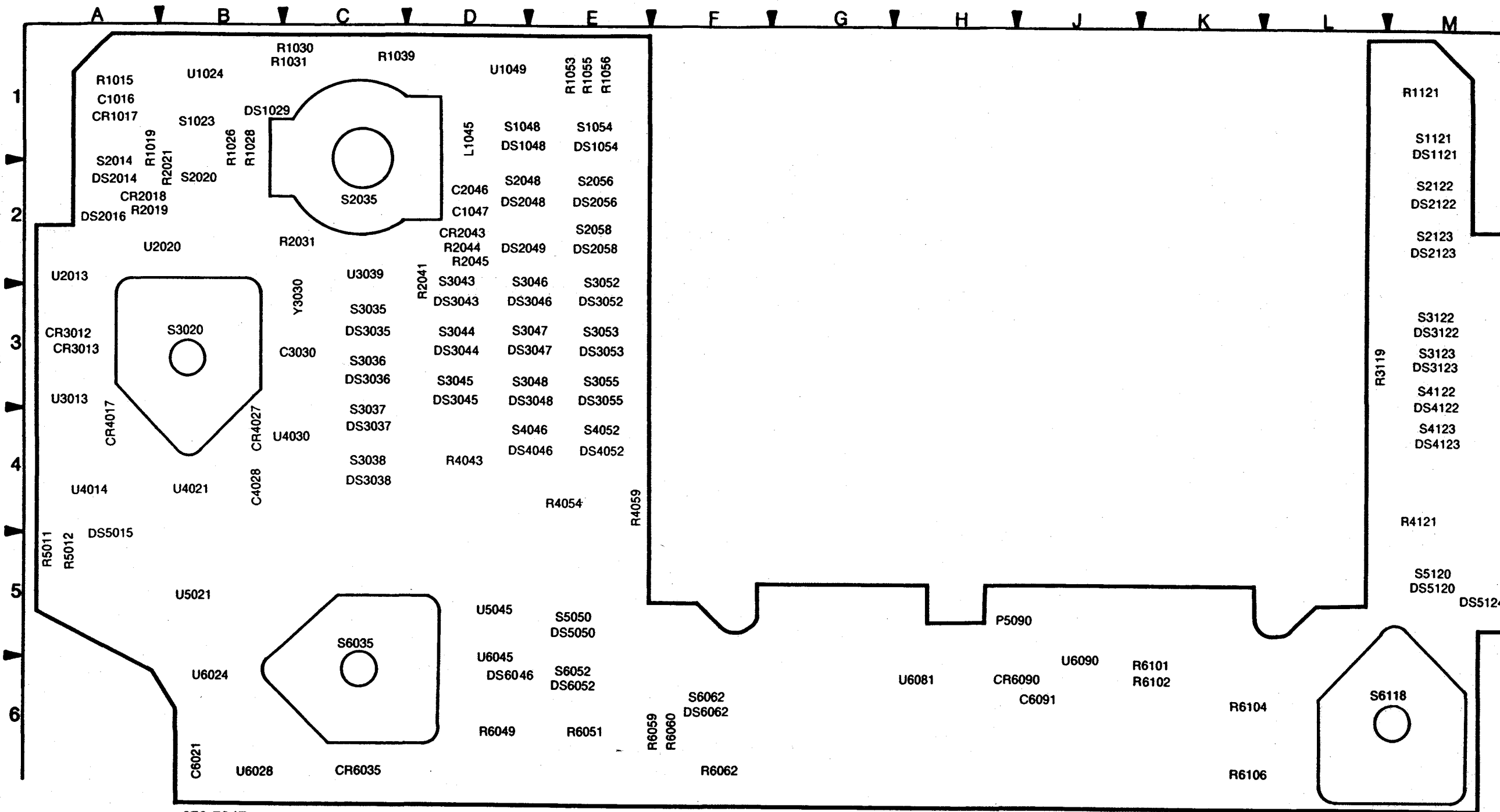

670-7947-

Fig. 10-61. A38—Front Panel circuit board.

5566-662

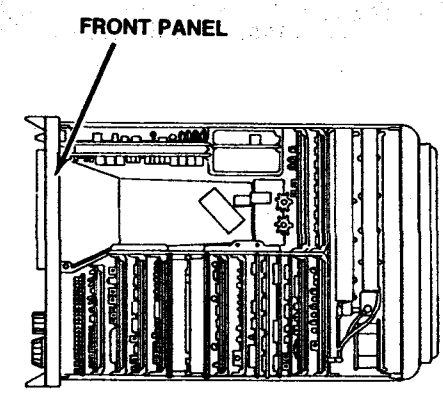

5566-664

FRONT PANEL



ASSEMBLY A36

CIRCUIT NUMBER	SCHEM LOCATION	BOARD LOCATION	CIRCUIT NUMBER	SCHEM LOCATION	BOARD LOCATION	CIRCUIT NUMBER	SCHEM LOCATION	BOARD LOCATION	CIRCUIT NUMBER	SCHEM LOCATION	BOARD LOCATION
C1016	B4	A1	DS5050	D5	E5	R4054H	C2	E4	S4122	E6	M3
C1047	F2	D2	DS5120	D3	M5	R4059B	F3	E4	S4123	D3	M4
C2046	F2	D2	DS5124	H1	M5	R4059C	C3	E4	S5050	D5	E5
C3030	B3	C3	DS6046	H1	D6	R4059D	C5	E4	S5120	D3	M5
C4028	C3	B4	DS6052	D3	E6	R4059E	C2	E4	S6035A	E3	C5
C6021	A3	B6	DS6062	F3	F6	R4059F	C1	E4	S6035B	E7	C5
C6091	F1	J6				R4059H	C4	E4	S6052	D3	E6
CR1017	B3	A1	L1045	G2	D1	R4121	H2	M4	S6062	E3	F6
CR2018	F5	A2	P5090	H1	H5	R5011	F5	A5	S6118	D6	M6
CR2043	F4	D2				R5012	G1	A5			
CR3012	G5	A3	R1015	B3	A1	R6049	H3	D6	U1024A	B3	B1
CR3013	G5	A3	R1019	F6	A1	R6051	G4	E6	U1024B	B2	B1
CR4017	F5	A4	R1026	B2	B1	R6059	H4	F6	U1024C	B2	B1
CR4027	F5	B4	R1028	B2	B1	R6060	G1	F6	U1024D	B3	B1
CR6035	F3	C6	R1030	B2	C1	R6062	H2	F6	U1024	F7	B1
CR6090	F1	J6	R1031	B2	C1	R6101	G1	K6	U1049	C6	D1
			R1039B	F4	C1	R6102	G1	K6	U2013A	G6	A2
DS1029	A2	B1	R1039C	F3	C1	R6104	H3	L6	U2013B	G5	A2
DS1048	F3	D1	R1039D	F4	C1	R6106	H3	L6	U2013	H7	A2
DS1054	F2	E1	R1039E	C5	C1				U2020A	G6	A2
DS1121	F1	M1	R1039F	C2	C1	S1023	D3	B1	U2020B	C3	A2
DS2014	F6	A2	R1039G	C2	C1	S1048	E3	D1	U2020B	F6	A2
DS2016	E6	A2	R1039H	F2	C1	S1054	E2	E1	U2020C	C3	A2
DS2048	F4	D2	R1053	C5	E1	S1121	E1	M1	U2020C	F4	A2
DS2049	F4	D2	R1055	F2	E1	S2014	E6	A2	U2020D	C2	A2
DS2056	D5	E2	R1056	F4	E1	S2020	D5	B2	U2020E	F1	A2
DS2058	F4	E2	R1121	H1	M1	S2035	A2	C2	U2020	G7	A2
DS2122	F1	M2	R2019	F1	A2	S2048	E4	D2	U3013A	G5	A3
DS2123	F2	M2	R2021	F6	B2	S2056	D4	E2	U3013B	G4	A3
DS3035	F2	C3	R2031	B2	C2	S2058	E4	E2	U3013	A4	A3
DS3036	D2	C3	R2041	B1	D2	S2122	E1	M2	U3039	B1	C2
DS3037	D5	C4	R2044	A1	D2	S2123	E2	M2	U4014A	G4	A4
DS3038	D2	C3	R2045	F2	D2	S3020	E5	B3	U4014B	G6	A4
DS3043	F2	D3	R3119B	C3	M3	S3035	E2	C3	U4014C	G5	A4
DS3044	D2	D3	R3119C	C3	M3	S3036	D2	C3	U4014	A4	A4
DS3045	D4	D3	R3119D	G1	M3	S3037	D5	C3	U4014	A4	A4
DS3046	D2	D3	R3119E	F6	M3	S3038	D2	C4	U4014	A4	A4
DS3047	D1	D3	R3119F	C1	M3	S3043	E2	D2	U4014	G7	A4
DS3048	D4	D3	R3119G	C1	M3	S3044	D2	D3	U4021	C1	B4
DS3052	D4	E3	R3119H	F1	M3	S3045	D4	D3	U4030	C3	B4
DS3053	D4	E3	R3119I	F1	M3	S3046	D2	D2	U5021	C2	B5
DS3055	D2	E3	R3119J	F2	M3	S3047	D1	D3	U5045	B5	D5
DS3122	D1	M3	R4043	H2	D4	S3048	D4	D3	U6024	A3	B6
DS4123	D1	M3	R4054B	C1	E4	S3052	D4	E2	U6028	B5	B6
DS4046	F1	D4	R4054C	C4	E4	S3053	D4	E3	U6045	B6	D5
DS4052	F1	E4	R4054D	C4	E4	S3055	D1	E3	U6081	B6	H6
DS4122	F6	M3	R4054E	C4	E4	S3122	D1	M3	U6090	F1	J6
DS4123	D3	M4	R4054F	F1	E4	S3123	D1	M3			
DS5015	H1	A4	R4054G	F1	E4	S4046	E1	D4	Y3030	B3	C3
						S4052	E1	E4			

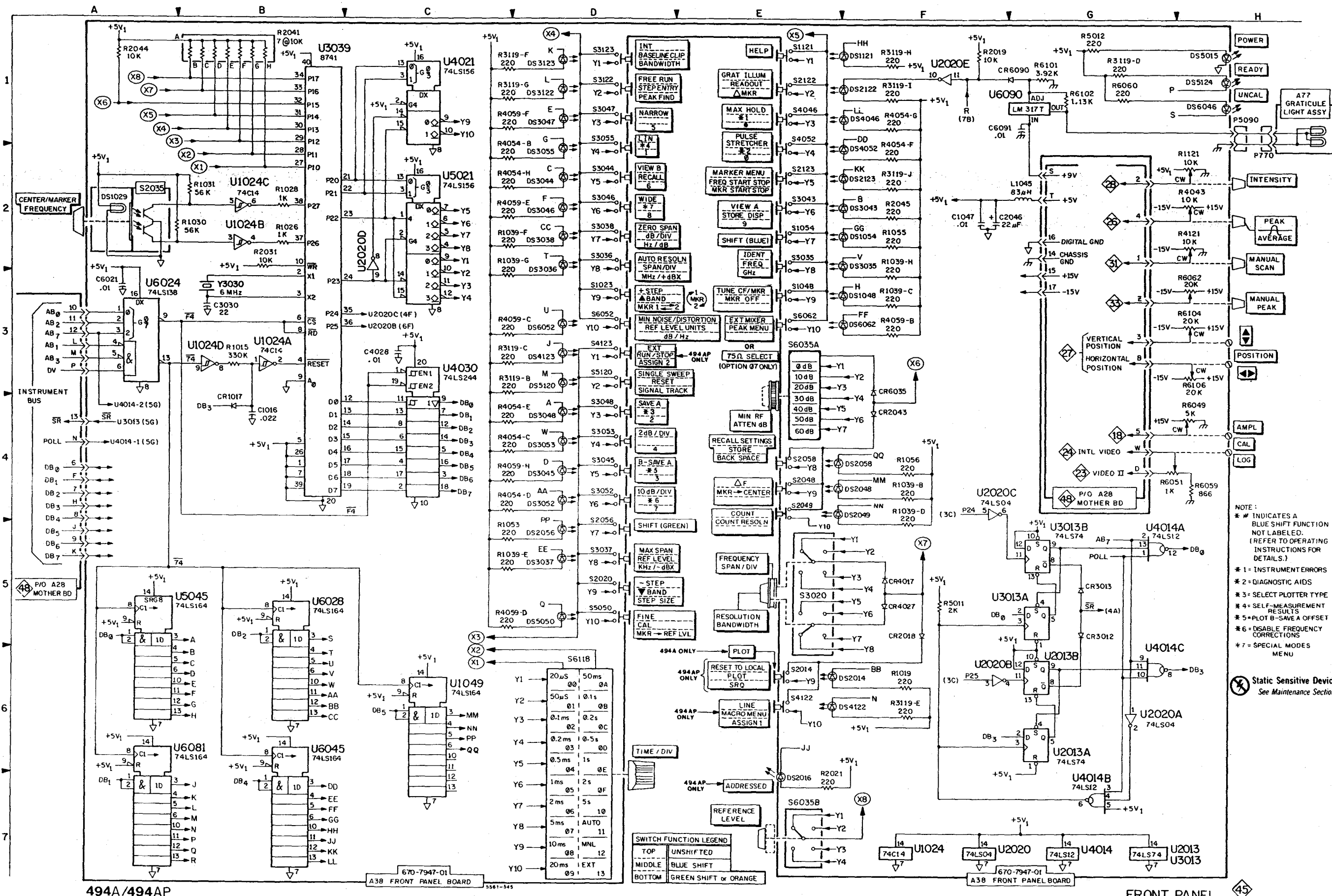

494A/494AP

A38 FRONT PANEL BOARD

FRONT PANEL

NOTE:
 *# INDICATES A
 BLUE SHIFT FUNCTION
 NOT LABELED.
 (REFER TO OPERATING
 INSTRUCTIONS FOR
 DETAILS.)
 *1 = INSTRUMENT ERRORS
 *2 = DIAGNOSTIC AIDS
 *3 = SELECT PLOTTER TYPE
 *4 = SELF-MEASUREMENT
 RESULTS
 *5 = PLOT B-SAVE A OFFSET
 *6 = DISABLE FREQUENCY
 CORRECTIONS
 *7 = SPECIAL MODES
 MENU

Static Sensitive Devices
 See Maintenance Section

MAIN POWER SUPPLY (PRIMARY SECTION)



ASSEMBLY A30A1

CIRCUIT NUMBER	SCHEM LOCATION	BOARD LOCATION	CIRCUIT NUMBER	SCHEM LOCATION	BOARD LOCATION	CIRCUIT NUMBER	SCHEM LOCATION	BOARD LOCATION
C1063	F2	E1	DS5112	D1	L5	R6041	D3	D6
C1095	C2	J1				R6045	C4	D6
C2096	C1	J2	E1094	C2	J1	R6046	D4	D6
C3064	F3	E3	E2095	C1	J2	R6048	C4	D6
C3071	F2	F3				R6052	A4	D6
C3074	F3	F3	J5041	E1	B4	R6056	D3	D6
C4082	E1	G4				R6057	B2	E6
C5038	B4	B5	L1081	F1	G1	R6058	B2	E6
C5071	E2	G5	L3088	E2	H3	R6061	B2	E6
C5072	E2	F5				R6063	C3	E6
C5082	E1	H5	P1091	C1	H1	R6073	E2	F5
C5084	F3	G5	P5033	B1	B5	R6074	E2	F6
C5085	F2	G5	P5042	B1	C5	R6075	E3	F6
C5113	E1	L5				R6076	E3	F6
C6033	E1	C5	Q2061	F3	E2	R6091	E2	H6
C6039	B4	C6	Q2071	F2	F2			
C6048	C4	D6	Q5023	B4	B5	RT2093	C1	H2
C6053	D3	D6	Q5032	B3	B5	RT2097	D2	H2
C6055	C3	D6	Q6034	B4	C6			
C6058	B3	E6	Q6077	E2	F6	S2103	C2	J2
C6059	B2	E6	Q6078	E3	F6			
C6062	C3	E6				T2080	F2	G2
C6068	C2	F6	R2057	F3	E2	T4071	F1	F4
C6069	C3	E6	R2073	F2	G2	T4084	E1	H4
C6071	E2	F6	R3084	F3	G3	T6044	A4	C6
C6072	E3	F6	R3088	D1	H3	T6081	F2	G6
C6101	E2	J6	R4083	E2	G4			
C6111	E2	L6	R4092	E2	H4	TP6053	C2	F6
			R5033	B3	C5	TP6065	E3	F6
CR2061	F2	F2	R5034	B4	B5			
CR2063	F3	F2	R5035	B4	C5	U3093	D2	J3
CR2065	F2	F2	R5036	B4	B5	U3103	D1	J4
CR2079	F2	G2	R5039	C3	C5	U5043	E1	C5
CR3096	D2	J3	R5042	E1	D5	U6036	C4	B6
CR3098	D1	J3	R5043	D3	D6	U6043	C3	C6
CR4094	D1	J4	R5047	C4	D5	U6046A	D4	C6
CR4095	D1	J4	R5083	F2	G5	U6046B	C4	C6
CR6047	D4	D6	R5086	F2	H5	U6053	D3	D6
CR6049	D3	D5	R5087	E2	H6	U6059	C2	E6
CR6052	A4	D6	R5111	D2	L5	U6063A	C3	E6
CR6053	D3	D6	R6022	B4	B6	U6063B	C2	E6
CR6055	D3	D6	R6032	B4	B6	U6069	E2	F6
CR6061	C3	E6	R6033	A4	C5			
CR6071	E2	F6	R6035	C4	B6	VR3089	D1	H3
CR6072	E2	F6	R6037	B4	B6	VR5073	E2	G6
CR6073	E3	G6	R6038	B4	C6			
CR6074	E3	G6	R6040	D1	C6			

Partial A30A1 also shown on diagram 47

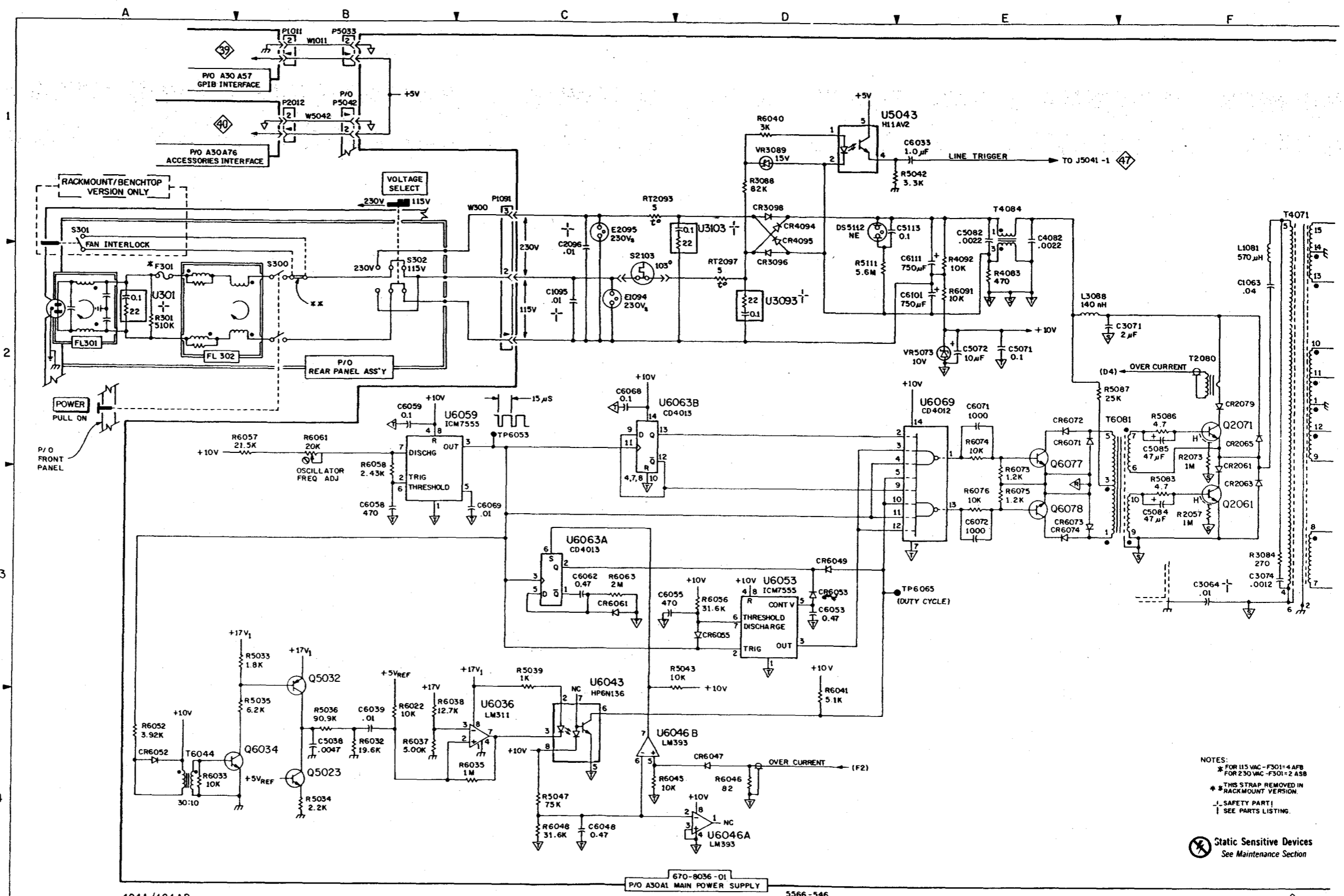

494A/494AP

670-8036-01
P/O A30A1 MAIN POWER SUPPLY

5566-546

MAIN POWER SUPPLY (PRIMARY SECTION)

NOTES:
 * FOR 115 VAC - F301-4 AFB
 * FOR 230 VAC - F301-2 ASB
 * THIS STRAP REMOVED IN RACKMOUNT VERSION.
 - SAFETY PART! SEE PARTS LISTING.

Static Sensitive Devices
 See Maintenance Section

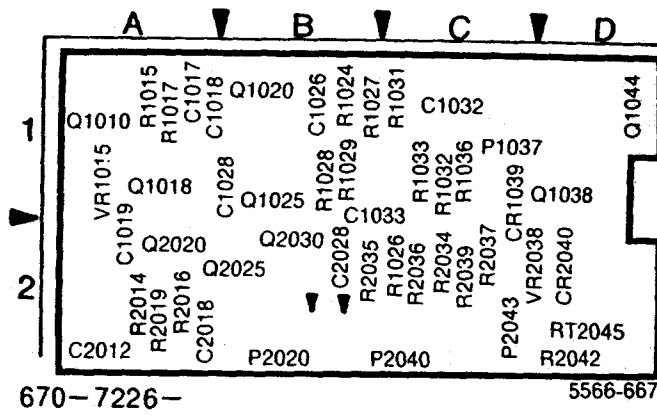
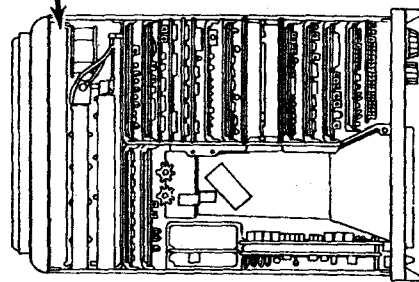

Fig. 10-63. A30A2—Fan Drive circuit board.

MAIN POWER SUPPLY
& FAN DRIVE



5566-668

MAIN POWER SUPPLY (SECONDARY & FAN DRIVE)



ASSEMBLY A30A1

CIRCUIT NUMBER	SCHEM LOCATION	BOARD LOCATION	CIRCUIT NUMBER	SCHEM LOCATION	BOARD LOCATION	CIRCUIT NUMBER	SCHEM LOCATION	BOARD LOCATION	CIRCUIT NUMBER	SCHEM LOCATION	BOARD LOCATION
C1055	G1	D1	C5054	G2	D5	F3038	A3	C3	R3032	K1	C2
C2024	K1	B2	C6010	M1	A6				R3033	K2	B3
C2030	H1	B1	C6019	K3	A6	L1051	K2	D1	R3034	J2	C3
C2032	H1	B2	C6025	G1	B6	L2048	H2	D2	R3036	J2	C3
C2033	J3	C1				L3012	L2	A3	R3037	J2	C3
C2034	H1	C2	CR1022	G1	B1	L3043	G2	D3	R3038	J2	C3
C2035	G1	C2	CR1034	G1	C1	L3047	H2	D3	R3039	J1	C3
C2041	G2	C2	CR1042	G1	C1	L4042	G2	C4	R4017	H2	A4
C2043	H2	C2	CR2027	K1	B2				R4018	L2	A4
C2045	G2	D2	CR2028	K1	B2	P3045	G3	C3	R4031	L1	B4
C2053	G1	D2	CR2035	H1	C2	P5042	L3	C5	R5014	L1	A5
C2057	G1	D2	CR3027	J2	B3				R5015	L1	A5
C3031	J1	B3	CR3028	J2	B3	Q2021	J1	B2	R5016	L1	A5
C3033	J2	C3	CR3035	J1	C2	Q2023	K1	B2	R5019	L1	A6
C3034	K1	C2	CR3052	G2	D2	Q2024	K1	B2	R8011	L1	A6
C3035	J2	B3	CR3053	G2	D3	Q2031	H1	B2	R8013	K2	A6
C3036	J2	B3	CR3054	G2	E3	Q3022	J2	B3	R8017	K3	A6
C3037	J3	C3	CR3055	G2	E3	Q3023	J2	B3	R8019	L1	A6
C3041	K2	C3	CR3056	G2	E3	Q5013	L1	A5	R8020	G1	B6
C3051	G3	D3	CR4021	L2	B4				R8021	G1	B6
C3057	G1	E3	CR4034	L1	C4	R2015	J1	A2	R8023	G1	B6
C4012	L2	A4	CR4037	L2	B4	R2017	K1	A2	R8024	L1	A6
C4014	M2	A4	CR4053	G2	E4	R2022	K1	A2	R8026	G1	B6
C4015	M2	A4	CR4057	G2	E4	R2025	K1	B2	R8029	G1	B6
C4016	L2	A4	CR4061	G3	E3	R2026	H1	B2			
C4022	K2	B4	CR4062	G2	E4	R2030	H1	B2	T4071	G2	F4
C4023	K1	B4	CR4063	G3	E4	R2031	J3	B2			
C4024	L2	B4	CR4065	G2	E4	R2032	H1	C1	TP6027	G1	B6
C4032	L1	B4	CR5031	G1	B5	R2034	H1	C2			
C4033	H2	C4	CR5052	G2	E5	R2035	H1	B2	U2037A	J1	B2
C4035	K2	C4	CR5055	G2	E5	R2036	H1	C2	U2037B	J1	B2
C4036	L2	B4	CR5062	G2	E5	R2037	H1	C2	U2037C	H1	B2
C4044	G2	C4	CR5065	G2	E5	R2038	H1	C2	U2037D	H1	B2
C4046	H2	D4	CR6014	L1	A6	R2039	K1	C2	U2037	J2	B2
C4051	H2	D4	CR6015	L1	A6	R3019	K1	A3	U3036A	J2	B3
C4055	H2	D4	CR6016	M1	A6	R3021	J1	B3	U3036B	J2	B3
C5010	L2	A5	CR6018	K1	A6	R3022	J2	B3	U3036	K2	B3
C5012	L2	A5				R3023	L2	A3	U5043	L1	C5
C5017	K2	A5	F1013	L2	A1	R3024	J2	B3	U6016A	L1	A6
C5018	J2	A5	F1017	J2	A1	R3025	L2	B3	U6016B	L1	A6
C5021	J2	B5	F1033	L2	C1	R3026	J2	B3	U6016	K2	A6
C5022	M1	A5	F1035	L2	C1	R3029	K3	B3			
C5051	H2	D5	F2013	K2	A2	R3031	J1	C3	VR6026	G1	B6

Partial A30A1 also shown on diagram 46

ASSEMBLY A30A2

CIRCUIT NUMBER	SCHEM LOCATION	BOARD LOCATION	CIRCUIT NUMBER	SCHEM LOCATION	BOARD LOCATION	CIRCUIT NUMBER	SCHEM LOCATION	BOARD LOCATION	CIRCUIT NUMBER	SCHEM LOCATION	BOARD LOCATION
C1017	G4	A1	P1037	D4	C1	R1015	G4	A1	R2034	H4	C2
C1018	J3	A1	P2020	K4	B2	R1017	G4	A1	R2035	H3	B2
C1019	H3	A2	P2040	G3	C2	R1024	J3	B1	R2036	H4	C2
C1026	J3	B1	P2043	J3	C2	R1026	H3	C2	R2037	J3	C2
C1028	H3	B1				R1027	J3	B1	R2039	J4	C2
C1032	J3	C1	Q1010	G3	A1	R1028	H4	B1	R2042	J3	D1
C1033	H3	B1	Q1018	H3	A1	R1029	J4	B1			
C2012	H3	A2	Q1020	J3	B1	R1031	J3	C1	RT2045	G3	D1
C2018	G3	A2	Q1025	J3	B1	R1032	J4	C1			
C2028	H3	B2	Q1038	J3	D1	R1033	H3	C1	VR1015	G4	A1
			Q1044	J3	D1	R1036	H4	C1	VR2038	J3	C2
CR1039	J4	C1	Q2020	H3	A2	R2014	H3	A2			
CR2040	J3	D1	Q2025	H3	B2	R2016	G3	A2			
			Q2030	H3	B2	R2019	H3	A2			

NOTES:

1. * = RF DECK CONNECTOR.
 2. ** = 2 LAYER CONNECTOR;
TOP LAYER - NUMBERED PINS.
BOTTOM LAYER - ALPHA PINS.
 3. UNLABELED PINS ARE NOT USED.
 4. EXCEPT AS NOTED, ABBREVIATIONS
ARE BASED ON ANSI Y1.1-1972 AND
IEEE STANDARD 488-1975.
- (EXCEPTIONS)
- A. PRESEL = PRESELECTOR
 - B. BLNK = BLANK
 - C. PROGRAM BIAS = PROGRAMMABLE BIAS
 - D. DRV = DRIVE
 - E. R/O = READOUT
 - F. XFER = TRANSFER
 - G. STO = STORAGE
 - H. V BKUP = VOLTAGE BACKUP
 - I. DS = DIGITAL STORAGE
 - J. VR = VARIABLE RESOLUTION
 - K. MNL = MANUAL
 - L. DSPL = DISPLAY

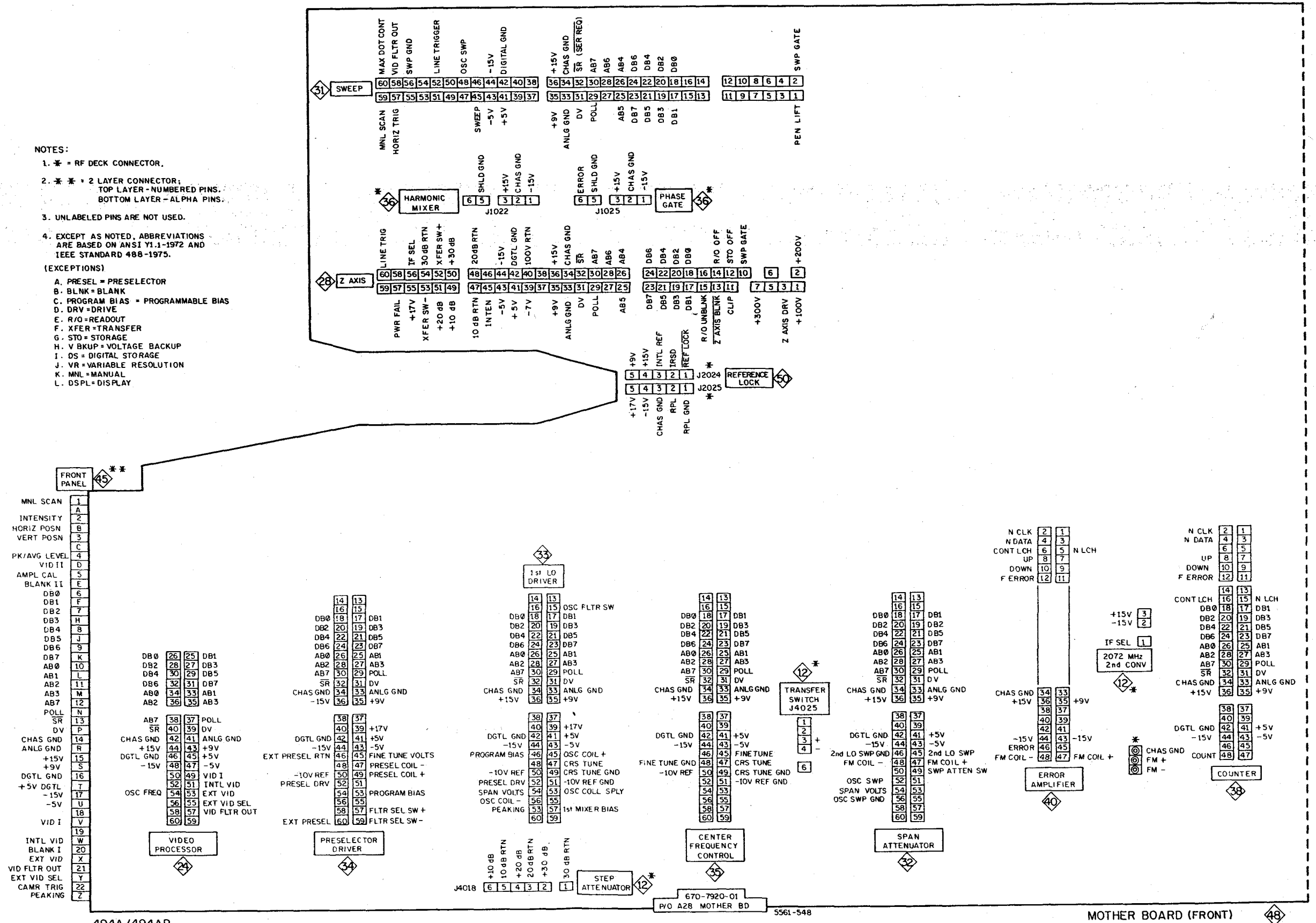

494A/494AP

670-7920-01
PVO A28 MOTHER BD
5561-548

MOTHER BOARD (FRONT)

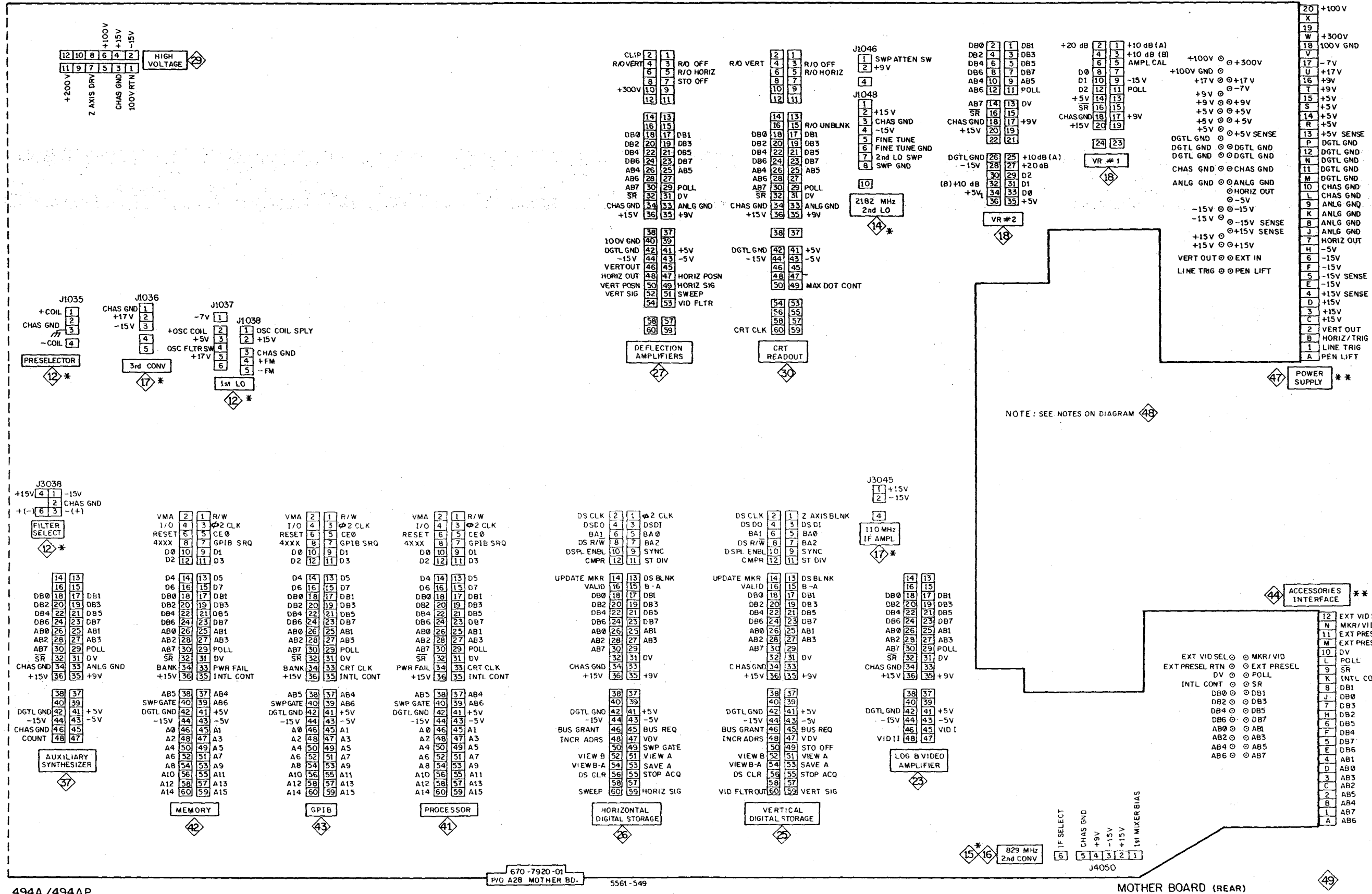

494A / 494AP

670-7920-01
P/O A28 MOTHER BD. 5561-549

MOTHER BOARD (REAR)

49

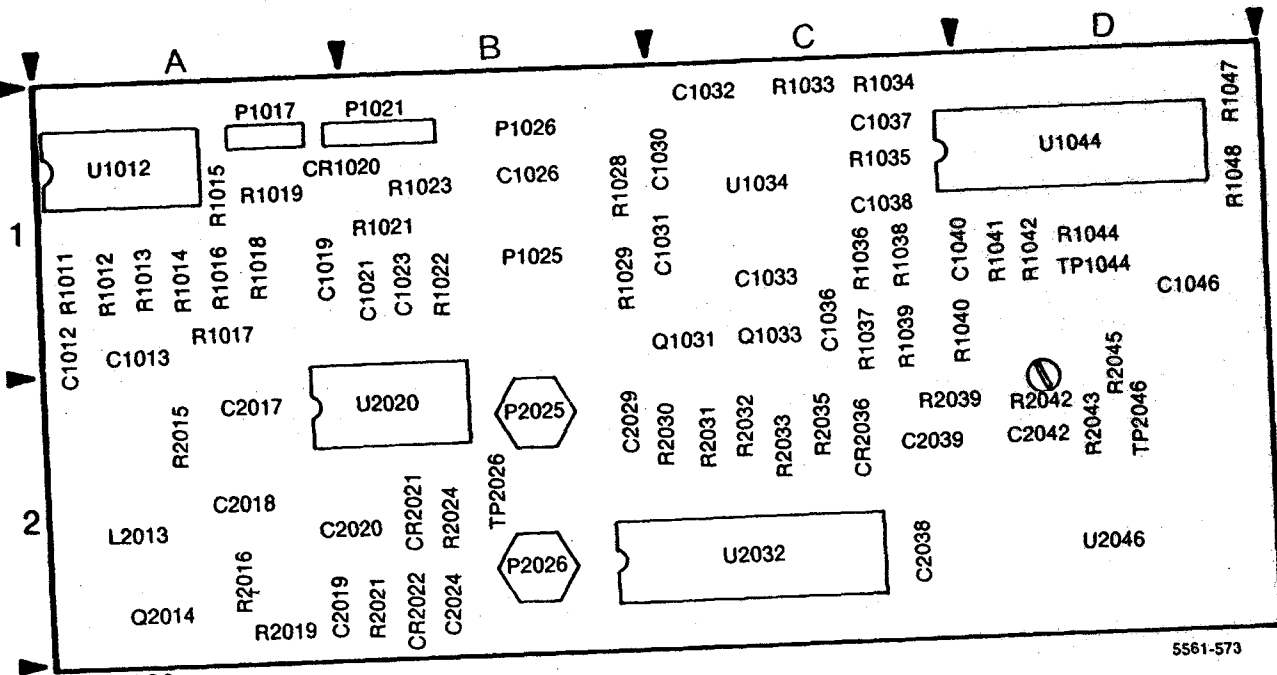
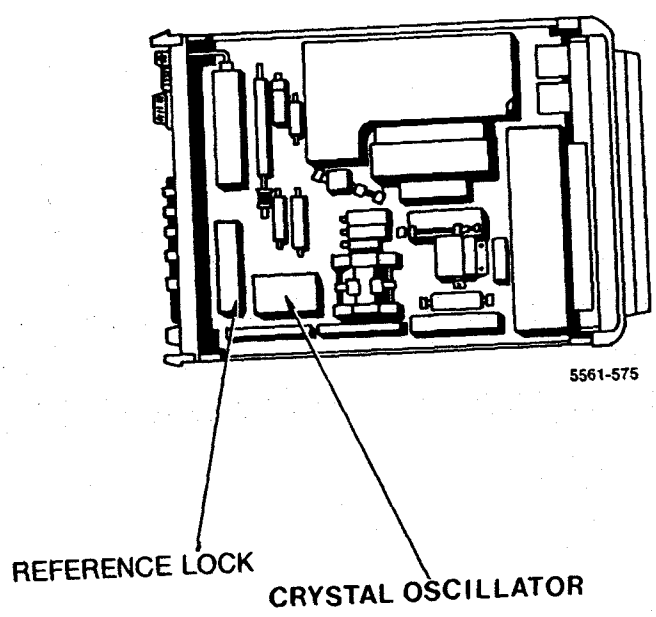

Fig. 10-64. A36A1—Reference Lock circuit board.



REFERENCE LOCK



ASSEMBLY A36A1

CIRCUIT NUMBER	SCHEM LOCATION	BOARD LOCATION	CIRCUIT NUMBER	SCHEM LOCATION	BOARD LOCATION	CIRCUIT NUMBER	SCHEM LOCATION	BOARD LOCATION
C1012	A4	A1	P1025	A1	B1	R1048	E2	D1
C1013	A4	A1	P1026	A2	B1	R2015	A4	A2
C1019	A1	A1	P2025	A1	B2	R2016	A3	A2
C1021	A1	B1	P2026	B1	B2	R2019	A3	A2
C1023	A1	B1				R2021	A3	A2
C1026	A2	B1	Q1031	B2	C1	R2024	A3	B2
C1030	A2	C1	Q1033	A2	C1	R2030	B2	C2
C1031	E1	C1	Q2014	B3	A2	R2031	B2	C2
C1032	F4	C1				R2032	B2	C2
C1033	F2	C1	R1011	E3	A1	R2033	C2	C2
C1036	F4	C1	R1012	E3	A1	R2035	B3	C2
C1037	E2	C1	R1013	E3	A1	R2039	D2	D2
C1038	E2	C1	R1014	E3	A1	R2042	D2	D2
C1040	E1	C1	R1015	F2	A1	R2043	B2	D2
C1046	E2	D1	R1016	E2	A1	R2045	E2	D2
C2017	B4	A2	R1017	A4	A1			
C2018	A4	A2	R1018	E2	A1	TP1044	C3	D1
C2019	B3	A2	R1019	F2	A1	TP2026	B3	B2
C2020	A4	A2	R1021	A1	B1	TP2046	D2	D2
C2024	A3	B2	R1022	A1	B1			
C2029	E4	B2	R1023	B2	B1	U1012	F3	A1
C2038	D2	D2	R1028	F1	B1	U1034	F2	C1
C2039	C2	D2	R1029	E2	B1	U1034	F4	C1
C2042	B2	D2	R1033	F4	C1	U1044A	E1	D1
			R1034	E2	C1	U1044B	E3	D1
CR1020	F2	B1	R1035	E2	C1	U1044	E4	D1
CR2021	A3	B2	R1036	F4	C1	U2020	B1	A2
CR2022	A3	B2	R1037	E2	C1	U2032A	C2	C2
CR2036	B3	C2	R1038	E1	C1	U2032B	C3	C2
			R1039	E2	C1	U2032C	D2	C2
L2013	A4	A2	R1040	E1	C1	U2032D	C3	C2
			R1041	D2	D1	U2032	E4	C2
P1017	F2	A1	R1042	D1	D1	U2046A	D2	D2
P1021	A2	B1	R1044	E1	D1	U2046B	B2	D2
P1021	F3	B1	R1047	E3	D1			

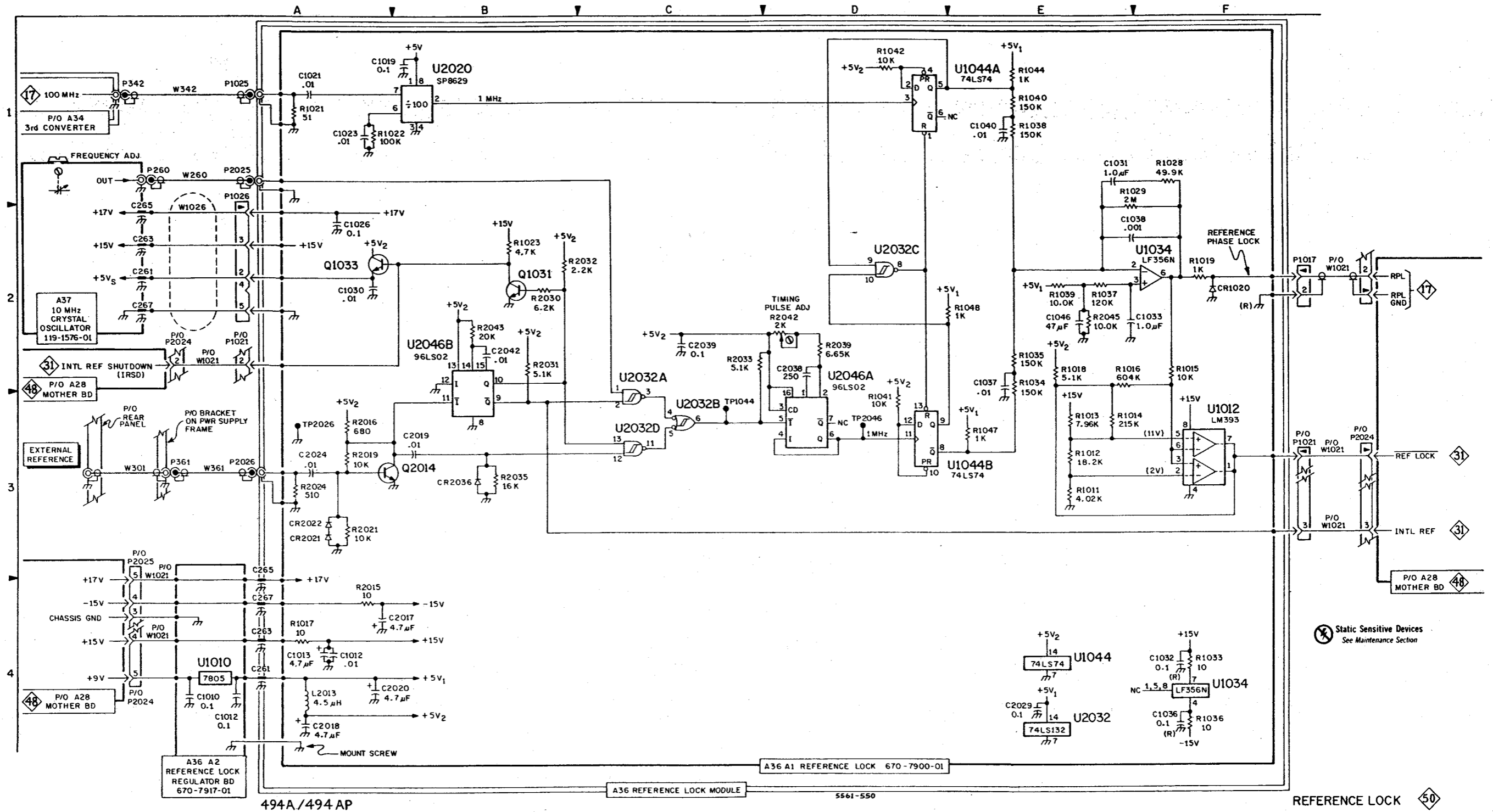

494A/494 AP

A36 REFERENCE LOCK MODULE

5561-550

REFERENCE LOCK 50

REPLACEABLE MECHANICAL PARTS

PARTS ORDERING INFORMATION

Replacement parts are available from or through your local Tektronix, Inc. Field Office or representative.

Changes to Tektronix instruments are sometimes made to accommodate improved components as they become available, and to give you the benefit of the latest circuit improvements developed in our engineering department. It is therefore important, when ordering parts, to include the following information in your order: Part number, instrument type or number, serial number, and modification number if applicable.

If a part you have ordered has been replaced with a new or improved part, your local Tektronix, Inc. Field Office or representative will contact you concerning any change in part number.

Change information, if any, is located at the rear of this manual.

ITEM NAME

In the Parts List, an Item Name is separated from the description by a colon (:). Because of space limitations, an Item Name may sometimes appear as incomplete. For further Item Name identification, the U.S. Federal Cataloging Handbook H6-1 can be utilized where possible.

FIGURE AND INDEX NUMBERS

Items in this section are referenced by figure and index numbers to the illustrations.

INDENTATION SYSTEM

This mechanical parts list is indented to indicate item relationships. Following is an example of the indentation system used in the description column.

```

1 2 3 4 5
Name & Description
Assembly and/or Component
Attaching parts for Assembly and/or Component
**** END ATTACHING PARTS ****
Detail Part of Assembly and/or Component
Attaching parts for Detail Part
**** END ATTACHING PARTS ****
Parts of Detail Part
Attaching parts for Parts of Detail Part
**** END ATTACHING PARTS ****

```

Attaching Parts always appear in the same indentation as the item it mounts, while the detail parts are indented to the right. Indented items are part of, and included with, the next higher indentation.

Attaching parts must be purchased separately, unless otherwise specified.

ABBREVIATIONS

ACTR	ACTUATOR	ELCTRN	ELECTRON	IN	INCH	SE	SINGLE END
ADPTR	ADAPTER	ELEC	ELECTRICAL	INCAND	INCANDESCENT	SECT	SECTION
ALIGN	ALIGNMENT	ELCTLT	ELECTROLYTIC	INSUL	INSULATOR	SEMCOND	SEMICONDUCTOR
AL	ALUMINUM	ELEM	ELEMENT	INTL	INTERNAL	SHLD	SHIELD
ASSEM	ASSEMBLED	EPL	ELECTRICAL PARTS LIST	LPHDR	LAMPHOLDER	SHLDR	SHOULDERED
ASSY	ASSEMBLY	EQPT	EQUIPMENT	MACH	MACHINE	SKT	SOCKET
ATTEN	ATTENUATOR	EXT	EXTERNAL	MECH	MECHANICAL	SL	SLIDE
AWG	AMERICAN WIRE GAGE	FIL	FILLISTER HEAD	MTG	MOUNTING	SLFLKG	SELF-LOCKING
BD	BOARD	FLEX	FLEXIBLE	NIP	NIPPLE	SLVG	SLEEVING
BRKT	BRACKET	FLH	FLAT HEAD	NON WIRE	NOT WIRE WOUND	SPR	SPRING
BRS	BRASS	FLTR	FILTER	OBDD	ORDER BY DESCRIPTION	SO	SQUARE
BRZ	BRONZE	FR	FRAME or FRONT	OD	OUTSIDE DIAMETER	SST	STAINLESS STEEL
BSHG	BUSHING	FSTNR	FASTENER	OVH	OVAL HEAD	STL	STEEL
CAB	CABINET	FT	FOOT	PH BRZ	PHOSPHOR BRONZE	SW	SWITCH
CAP	CAPACITOR	FKD	FIXED	PL	PLAIN or PLATE	T	TUBE
CER	CERAMIC	GSKT	GASKET	PLSTC	PLASTIC	TERM	TERMINAL
CHAS	CHASSIS	HDL	HANDLE	PN	PART NUMBER	THD	THREAD
CKT	CIRCUIT	HEX	HEXAGON	PNH	PAN HEAD	THK	THICK
COMP	COMPOSITION	HEX HD	HEXAGONAL HEAD	PWR	POWER	TNSN	TENSION
CONN	CONNECTOR	HEX SOC	HEXAGONAL SOCKET	RCPT	RECEPTACLE	TPG	TAPPING
COV	COVER	HLCPS	HELICAL COMPRESSION	RES	RESISTOR	TRH	TRUSS HEAD
CPLG	COUPLING	HLEXT	HELICAL EXTENSION	RGD	RIGID	V	VOLTAGE
CRT	CATHODE RAY TUBE	HV	HIGH VOLTAGE	RLF	RELIEF	VAR	VARIABLE
DEG	DEGREE	IC	INTEGRATED CIRCUIT	RTNR	RETAINER	W/	WITH
DWR	DRAWER	ID	INSIDE DIAMETER	SCH	SOCKET HEAD	WSHR	WASHER
		IDENT	IDENTIFICATION	SCOPE	OSCILLOSCOPE	XFMR	TRANSFORMER
		IMPLR	IMPELLER	SCR	SCREW	XSTR	TRANSISTOR

CROSS INDEX - MFR. CODE NUMBER TO MANUFACTURER

Mfr. Code	Manufacturer	Address	City, State, Zip Code
00261	GENERAL ELECTRIC CO FOOD SERVICE EQUIPMENT BUSINESS DEPT	14TH AND ARNOLD STS	CHICAGO HEIGHTS IL 60411
00779	AMP INC	2800 FULLING MILL PO BOX 3608	HARRISBURG PA 17105
01536	TEXTRON INC CAMCAR DIV	1818 CHRISTINA ST	ROCKFORD IL 61108
05574	SEMS PRODUCTS UNIT VIKING CONNECTORS INC SUB OF CRITON CORP	21001 NORDHOFF ST	CHATSWORTH CA 91311-5911
05617	BELL INDUSTRIES, ELECTRONIC DISTR. D IV.	1900 132ND, NE	BELLEVUE, WA 98005
05820	EG AND G WAKEFIELD ENGINEERING	60 AUDUBON RD	WAKEFIELD MA 01880-1203
06383	PANDUIT CORP	17301 RIDGELAND	TINLEY PARK IL 07094-2917
06540	MITE CORP AMATOM ELECTRONIC HARDWARE DIV	446 BLAKE ST	NEW HAVEN CT 06515-1238
06915	RICHCO PLASTIC CO	5825 N TRIPP AVE	CHICAGO IL 60646-6013
06950	SCREWCORP VSI AEROSPACE PRODUCTS DIV SUB OF FAIRCHILD INDUSTRIES INC	13001 E TEMPLE AVE PO BOX 730	CITY OF INDUSTRY CA 91746-1417
07416	NELSON NAME PLATE CO	3191 CASITAS	LOS ANGELES CA 90039-2410
08530	RELIANCE MICA CORP	341-39TH ST	BROOKLYN NY 11212-2903
09422	PLASTIC STAMPING CORP	2216 W ARMITAGE AVE	CHICAGO IL 60647-4461
09772	WEST COAST LOCKWASHER CO INC	16730 E JOHNSON DRIVE P O BOX 3588	CITY OF INDUSTRY CA 91744
09922	BURNDY CORP	RICHARDS AVE	NORWALK CT 06852
11897	PLASTIGLIDE MFG CORP	2701 W EL SEGUNDO BLVD	HAWTHORNE CA 90250-3318
12327	FREEWAY CORP	9301 ALLEN DR	CLEVELAND OH 44125-4632
12360	ALBANY FASTENERS PAWTUCKET FASTENER DIV	327 PINE ST PO BOX 879	PAWTUCKET RI 02862
16428	COOPER BELDEN ELECTRONIC WIRE AND CA SUB OF COOPER INDUSTRIES INC		
18565	CHOMERICS INC	77 DRAGON COURT	WOBURN MA 01801-1039
19505	APPLIED ENGINEERING PRODUCTS	1475 WHALLEY AVE PO BOX A-D	NEW HAVEN CT 06525
22526	DU PONT E I DE NEMOURS AND CO INC DU PONT ELECTRONICS DEPT	515 FISHING CREEK RD	NEW CUMBERLAND PA 17070-3007
23050	PRODUCT COMPONENTS CORP	30 LORRAINE AVE	MT VERNON NY 10553-1222
24931	SPECIALTY CONNECTOR CO INC	2100 EARLYWOOD DR PO BOX 547	FRANKLIN IN 46131
26233	NYLOK FASTENER CORP	1161 E SANDHILL AVE SUITE D PO BOX 5228	CARSON CA 90749
26364	COMPONENTS CORP	6 KINSEY PLACE	DENVILLE NJ 07834-2611
26365	GRIES DYNACAST CO DIV OF COATS AND CLARK INC	125 BEECHWOOD AVE	NEW ROCHELLE NY 10802
29587	BUNKER RAMO CORP AMPHENOL INDUSTRIAL DIV	1830 S 54TH AVE	CHICAGO IL 60650
31781	EDAC INC	20 RAILSIDE RD	DON MILLS ONT CAN M3A 1A4
53217	TECHNICAL WIRE PRODUCTS INC DBA TECKNIT INC	320 N NOPAL ST	SANTA BARBARA CA 93103-3225
55285	BERGQUIST CO INC THE	5300 EDINA INDUSTRIAL BLVD	MINNEAPOLIS MN 55435-3707
56878	SPS TECHNOLOGIES INC AEROSPACE & INDUSTRIAL PRODUCTS DIV	HIGHLAND AVE	JENKINTOWN PA 19046
70485	ATLANTIC INDIA RUBBER WORKS INC	571 W POLK ST	CHICAGO IL 60607
70903	COOPER BELDEN ELECTRONICS WIRE AND C SUB OF COOPER INDUSTRIES INC		
71400	BUSSMANN DIV OF COOPER INDUSTRIES INC	114 OLD STATE RD PO BOX 14460	ST LOUIS MO 63178
71468	ITT CANNON DIV OF ITT CORP	666 E DYER RD	SANTA ANA CA 92702
72228	AMCA INTERNATIONAL CORP CONTINENTAL SCREW CO DIV	459 MT PLEASANT	NEW BEDFORD MA 02742
73743	FISCHER SPECIAL MFG CO	111 INDUSTRIAL RD	COLD SPRING KY 41076-9749
74868	AMPHENOL CORP R F CONNECTORS (OPNS)	1 KENNEDY AVE	DANBURY CT 06810-5803
74970	JOHNSON E F CO	299 10TH AVE S W	WASECA MN 56093-2539
75915	LITTELFUSE INC SUB TRACOR INC	800 E NORTHWEST HWY	DES PLAINES IL 60016-3049

CROSS INDEX - MFR. CODE NUMBER TO MANUFACTURER

Mfr. Code	Manufacturer	Address	City, State, Zip Code
76854	OAKGRIGSBY AN OAK INDUSTRIES INC CO	88 N DUGAN ROAD PO BOX 890	SUGAR GROVE IL 60544-0890
77250	ALLIED PRODUCTS CORP PHEOLL MFG CO DIV	5700 W ROOSEVELT RD	CHICAGO IL 60650-1156
77900	ILLINOIS TOOL WORKS SHAKEPROOF DIV	ST CHARLES RD	ELGIN IL 60120
78189	ILLINOIS TOOL WORKS INC SHAKEPROOF DIV	ST CHARLES ROAD	ELGIN IL 60120
78488	STACKPOLE CORP THE	201 STACKPOLE ST	ST MARYS PA 15857-1401
79136	WALDES KOHINOOR INC	47-16 AUSTEL PLACE	LONG ISLAND CITY NY 11101-4402
80009	TEKTRONIX INC	14150 SW KARL BRAUN DR PO BOX 500	BEAVERTON OR 97077-0001
81350	JOINT ARMY-NAVY SPECIFICATIONS, PROMULGATED BY MILITARY DEPARTMENTS UNDER AUTHORITY OF DEFENSE STANDARD- IZATION MANUAL 4120 3-M		
83385	MICRODOT MFG INC GREER-CENTRAL DIV	3221 W BIG BEAVER RD	TROY MI 48098
83486	ELCO INDUSTRIES INC	1101 SAMUELSON RD	ROCKFORD IL 61101
85471	BOYD CORP	13885 RAMOMA AVE	CHINO CA 91710
85480	BRADY W H CO CORP H Q INDUSTRIAL PRODUCTS DIV	2221 W CAMDEN RD PO BOX 2131	MILWAUKEE WI 53209
86928	SEASTROM MFG CO INC	701 SONORA AVE	GLENDALE CA 91201-2431
91260	CONNOR SPRING AND MFG CO A SLOSS AND BRITTAN INC CO	1729 JUNCTION AVE	SAN JOSE CA 95112
91836	KINGS ELECTRONICS CO INC	40 MARBLEDALE ROAD	TUCKAHOE NY 10707-3420
93459	WEINSCHTEL ENGINEERING CO INC	1 WEINSCHTEL LANE	GAITHERSBURG MD 20877
93907	TEXTRON INC CAMCAR DIV	600 18TH AVE	ROCKFORD IL 61108-5181
95987	BRADY/WECKESSER MFG CO	4444 WEST IRVING PARK RD	CHICAGO IL 60641
98159	RUBBER TECK INC	19115 HAMILTON AVE PO BOX 389	GARDENA CA 90247
S3109	FELLER	72 Veronica Ave Unit 4	Summerset NJ 08873
S3629	SCHURTER AG H C/O PANEL COMPONENTS CORP	2015 SECOND STREET	BERKELEY CA 94170
TK0409	HUMKE KEN R	2211 NW NICOLAI PO BOX 5128	PORTLAND OR 97208
TK0428	DLB INDUSTRIES		FRESNO CA
TK0433	PORTLAND SCREW CO		
TK0435	LEWIS SCREW CO	4300 S RACINE AVE	CHICAGO IL 60609-3320
TK0456	ARROW FASTENERS INC	2112 AMERICAN AVE	HAYWARD CA 94545
TK0858	STAUFFER SUPPLY CO (DIST)		
TK0861	H SCHURTER AG DIST PANEL COMPONENTS	2015 SECOND STREET	BERKELEY CA 94170
TK1319	MORELLIS Q & D PLASTICS		
TK1375	ESAM		
TK1452	SHELLEY-RAGON INC (DIST)		
TK1483	TEKA PRODUCTS		
TK1566	METALMATIX INC	2088 WALSH BLVD	SANTA CLARA CA 95050
TK1650	AMP INC		
TK2065	NORTH STAR NAMEPLATE		

Replaceable Mechanical Parts
494A/494AP Service Vol.2

Fig. & Index No.	Tektronix Part No.	Serial/Assembly No.		Qty	12345 Name & Description	Mfr. Code	Mfr. Part No.
		Effective	Discnt				
1-1	200-3195-00			1	COVER, FRONT: POLYCARBONATE	80009	200-3195-00
-2	348-0585-00			4	FOOT, CABINET: BLUE, PLASTIC (ATTACHING PARTS)	80009	348-0585-00
-3	211-0674-00			4	SCREW, MACHINE: 6-32 X 0.312, TRH, STL (END ATTACHING PARTS)	83486	ORDER BY DESCR
-4	334-5221-00			1	MARKER, IDENT: MKD CAUTION	80009	334-5221-00
-5	348-0587-00			4	FOOT, CABINET: BLUE, PLASTIC (ATTACHING PARTS)	80009	348-0587-00
-6	211-0674-00			4	SCREW, MACHINE: 6-32 X 0.312, TRH, STL (END ATTACHING PARTS)	83486	ORDER BY DESCR
-7	366-0579-00			2	PUSH BUTTON: ALUMINUM	80009	366-0579-00
-8	367-0345-00	B010100	B020659	1	HANDLE ASSEMBLY:	80009	367-0345-00
	367-0345-01	B020660		1	HANDLE ASSY: 49X FAMILY (ATTACHING PARTS)	80009	367-0345-01
-9	212-0560-00			6	SCREW, MACHINE: 10-32 X 0.312, FLH, 100 DEG (END ATTACHING PARTS)	93907	ORDER BY DESCR
-10	380-0668-00			2	HOUSING, INDEX: (ATTACHING PARTS)	80009	380-0668-00
-11	213-0858-00			8	SCREW, TPG, TR: 6-32 X 0.5 L, TAPTITE, FLH (END ATTACHING PARTS)	83385	ORDER BY DESCR
-12	200-2694-00			2	COVER, INDEX: ALUMINUM (ATTACHING PARTS)	80009	200-2694-00
-13	213-0918-00			6	SCREW, TPG, TR: 8-32 X 0.625, FLH, 82 DEG, POZ (END ATTACHING PARTS)	72228	ORDER BY DESCR
-14	214-3200-00			2	SPRING, HLCPS: 0.798 OD X 1.1 L, CLE, MUM	80009	214-3200-00
-15	105-0893-00			2	INDEX RLSE, HDL:	80009	105-0893-00
-16	105-0894-00			2	INDEX STOP, HDL:	80009	105-0894-00
-17	214-3198-00			2	INDEX, HANDLE:	80009	214-3198-00
-18	348-0589-00			2	FOOT, CABINET: BLUE, PLASTIC (ATTACHING PARTS)	80009	348-0589-00
-19	212-0630-01			4	SCREW, SPCL MACH: 10-24 X 1.55 L, FLH, 45 DEG	TK0858	ORDER BY DESCR
-20	211-0513-00			4	SCREW, MACHINE: 6-32 X 0.625, PNH, STL (END ATTACHING PARTS)	93907	B80-00032-003
-21	334-6455-00			1	MARKER, IDENT: MKD AVANTI (494A ONLY)	07416	334-6455-00
	334-6456-00	B010100	B020659	1	MARKER, IDENT: MKD AVANTIP	07416	334-6456-00
	334-6456-01	B020660		1	MARKER, IDENT: MARKED 494AP (494AP ONLY)	80009	334-6456-01
-22	437-0232-03			1	CABINET, SA:	80009	437-0232-03

Date: 4-4-88

Change Reference: M66557

Product: see list

Manual Part No: see list

Product Group: 26

<u>INSTRUMENT</u>	<u>MANUAL</u>	<u>EFF/ SN</u>
492/P Service 2	070-3784-01	B056139
492/P 6 Service 2	070-4233-00	B621913
492A/AP Service 2	070-5566-01	B010707
492B/BP Service 2	070-5566-01	B010100
494/P Service 2	070-4417-01	B011156
494A/AP Service 2	070-5561-00	B010425
495/P Service 2	070-5085-00	B020317
496/P Service 2	070-3482-00	B021913
2753P Service 2	070-6307-00	B020117
2754/P Service 2	070-6098-00	B010233
2755/P Service 2	070-6033-01	B010295
2755A/AP Service 2	070-6033-01	B010100
2756P Service 2	070-6319-00	B010205

ELECTRICAL PARTS LIST

CHANGE:

A64	672-0162-04	DEFLECTION AMP. CIRCUIT BOARD
A64A1	671-0372-01	DEFLECTION AMP. CIRCUIT BOARD ASSY

ADD:

A64A1C2020	283-0139-00	CAP, FXD, CER DI:150PF, 20%, 50V
A64A1C2030	283-0139-00	CAP, FXD, CER DI:150PF, 20%, 50V
A64A1C4080	283-0139-00	CAP, FXD, CER DI:150PF, 20%, 50V
A64A1C5090	283-0139-00	CAP, FXD, CER DI:150PF, 20%, 50V
A64A1C6064	283-0139-00	CAP, FXD, CER DI:150PF, 20%, 50V

Date: 5-26-88
Product: See list

Change Reference: M66924
Manual Part No: See list

Product Group: 26

INSTRUMENT	MANUAL	EFF/SN
492/P Service 2	070-3784-01	B056140
492P/6 Service 2	070-4233-00	B621914
494/P Service 2	070-4417-01	B020363
495/P Service 2	070-5085-00	B020122
496/P Service 2	070-3482-00	B021914
492A/AP Service 2	070-5566-01	B010707
492B/BP Service 2	070-5566-01	B010129
494A/AP Service 2	070-5561-00	B010471
2753P Service 2	070-6307-00	B020122
2754/P Service 2	070-6098-00	B010245
2755/P Service 2	070-6033-01	B010294
2755A/AP Service 2	070-6033-01	B010107
2756P Service 2	070-6319-00	B010205

CHANGE TO:

A22	650-0296-05	2ND LO ASSY:PHASE LOCK (492/P ONLY)
A22	650-0266-05	2ND LO ASSY:PHASE LOCK (492/P OPT. 6 & 496/P ONLY)
A22	650-1717-02	2ND LO ASSY:PHASE LOCK (495/P & 2753P ONLY)
A22	650-0736-03	2ND LO ASSY:PHASE LOCK (494/P,492A/AP, 492B/BP, 494A/AP,2754/P, 2755/P,2755A/AP & 2756P)
A22A2	119-1457-04	PH LOCK LO ASSY (492/P ONLY)
A22A2	119-1412-02	PH LOCK LO ASSY (492/P OPT. 6 & 496/P ONLY)
A22A2A2	670-7076-02	CIRCUIT BD ASSY:2200MHZ REF (ALL INSTRUMENTS LISTED)
A22A2A2C1025	283-0185-00	CAP,FXD,CER DI 2.5PF,0.5%,50V
A22A2A2C1029	283-0330-00	CAP,FXD,CER DI 100PF,5%,50V
A22A2A2C1038	283-0260-00	CAP,FXD,CER DI 5.6PF,+/-0.25PF,200V
A22A2A2L1025	108-0215-00	COIL,RF FIXED 1.1UH ON FORM
A22A2A2L1034	108-0262-00	COIL,RF FIXED 505NH ON FORM

ADD:

A22A2A2L1029 108-1001-00 COIL,RF FIXED 26NH ON FORM

REMOVE:

A22A2A2C1036 283-0154-00 CAP,FXD,CER DI 22PF,5%,50V

NEW SCHEMATIC

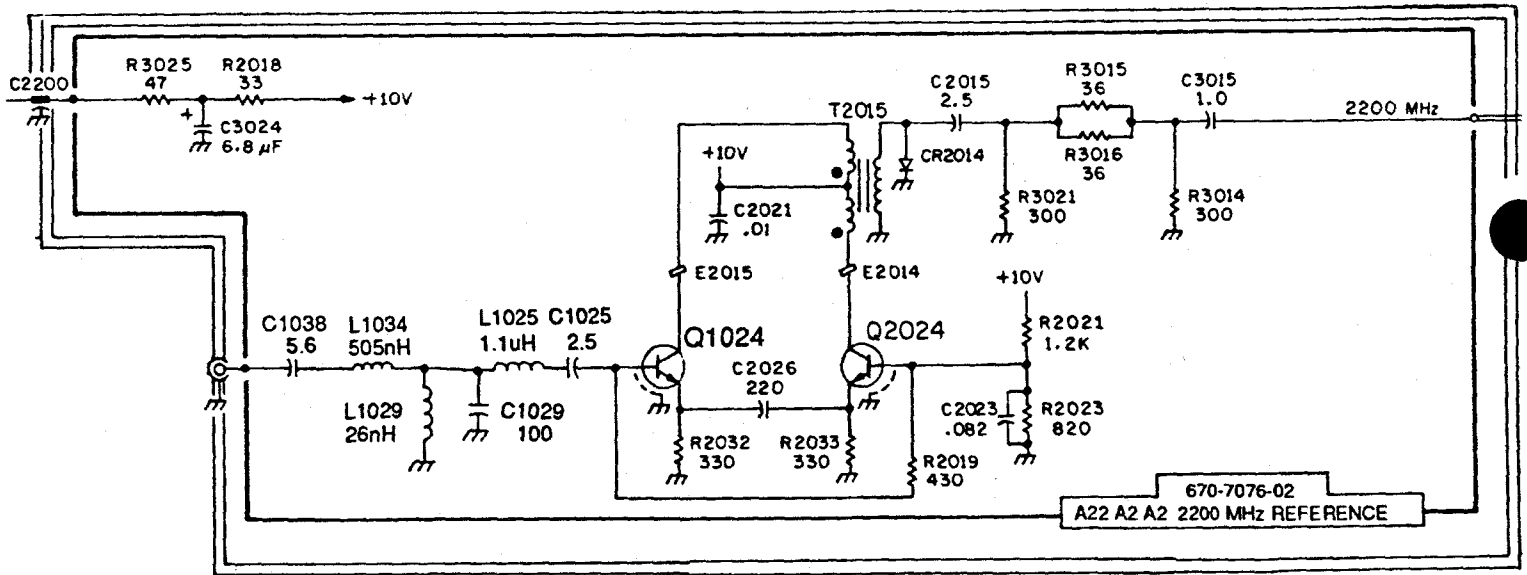

The parts on page 1 are located on the A22A2A2 2200MHz REFERENCE CIRCUIT BD and shown on A22A2 2182 MHz PHASE LOCK 2nd LO ASSY.

Date: 8-18-88
Product: See list

Change Reference: M66071 Revision
Manual Part No: See list

Product Group: 26

INSTRUMENT	PART NO.	EFF/SN
492A/AP	070-5566-01	B010712
492B/BP	070-5566-01	B010130
494A/AP	070-5561-00	B010494
495/P	070-5085-00	B020367
2753P	070-6307-00	B020124
2754/P	070-6098-00	B010252
2755/P	070-6033-01	B010294
2755A/AP	070-6033-01	B010105
2756P	070-6319-00	B010205

ELECTRICAL PARTS LIST CHANGES

CHANGE TO:

A61	672-0163-02	CIRCUIT BD ASSY:VERTICAL DIGITAL STORAGE
A61A1	670-9099-02	CIRCUIT BD ASSY: DIGITAL STORAGE
A61A1R4045	321-0333-00	RES,FXD,FILM,28.7K OHM,1%,0.125W
A61A1R4046	321-0387-00	RES,FXD,FILM,105K OHM,1%,0.125W

ADD:

NOTE: The following Adds ONLY affect the 494A/AP, 495/P, 2753P, 2754/P, 2756P, 492B/BP AND 2755A/AP.

A64	672-1300-00	CIRCUIT BD ASSY:DEFLECTION AMP (OPT. 43 ONLY)
A64A1	671-0803-00	CIRCUIT BD ASSY:DEFLECTION AMP (OPT. 43 ONLY)
A64A1R5087	321-0297-00	RES,FXD,FILM,12.1K OHM,1%,0.125W (OPT. 43 ONLY)
V100	154-0934-00	ELECTRON TUBE (OPT. 43 ONLY)

Date: 3-13-89
 Product: See List

Change Reference: M66829
 Manual Part No: See List Product Group: 2E

<u>INSTRUMENT</u>	<u>PART NUMBER</u>	<u>EFF/SN</u>
494A/AP Service 2	070-5561-00	B010542
2753P Service 2	070-6307-00	B020146
2756P Service 2	070-6319-00	B010204

MECHANICAL PARTS LIST CHANGES

REMOVE:

<u>Fig. & Index</u>	<u>QTY</u>	<u>Part number</u>	<u>Description</u>
3-95	3	343-0013-00	CLAMP, LOOP

ADD:

2	343-0006-00	CLAMP, LOOP
1	343-0549-00	STRAP, TIEDOWN

Partial view of Power Supply showing the locations of cable clamps and cable tie.

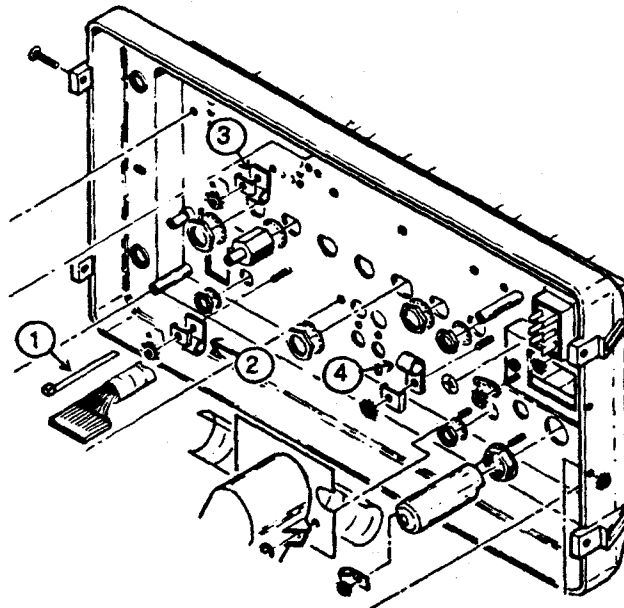

<u>Fig.1</u>	<u>Part #</u>	<u>Qty</u>
1	343-0549-00	1
2	343-0013-00	1
3	343-0006-00	1
4	343-0006-00	1

Figure 1

Note: New figure locations for the above part numbers will be designated in the service manual at time of next rebind.

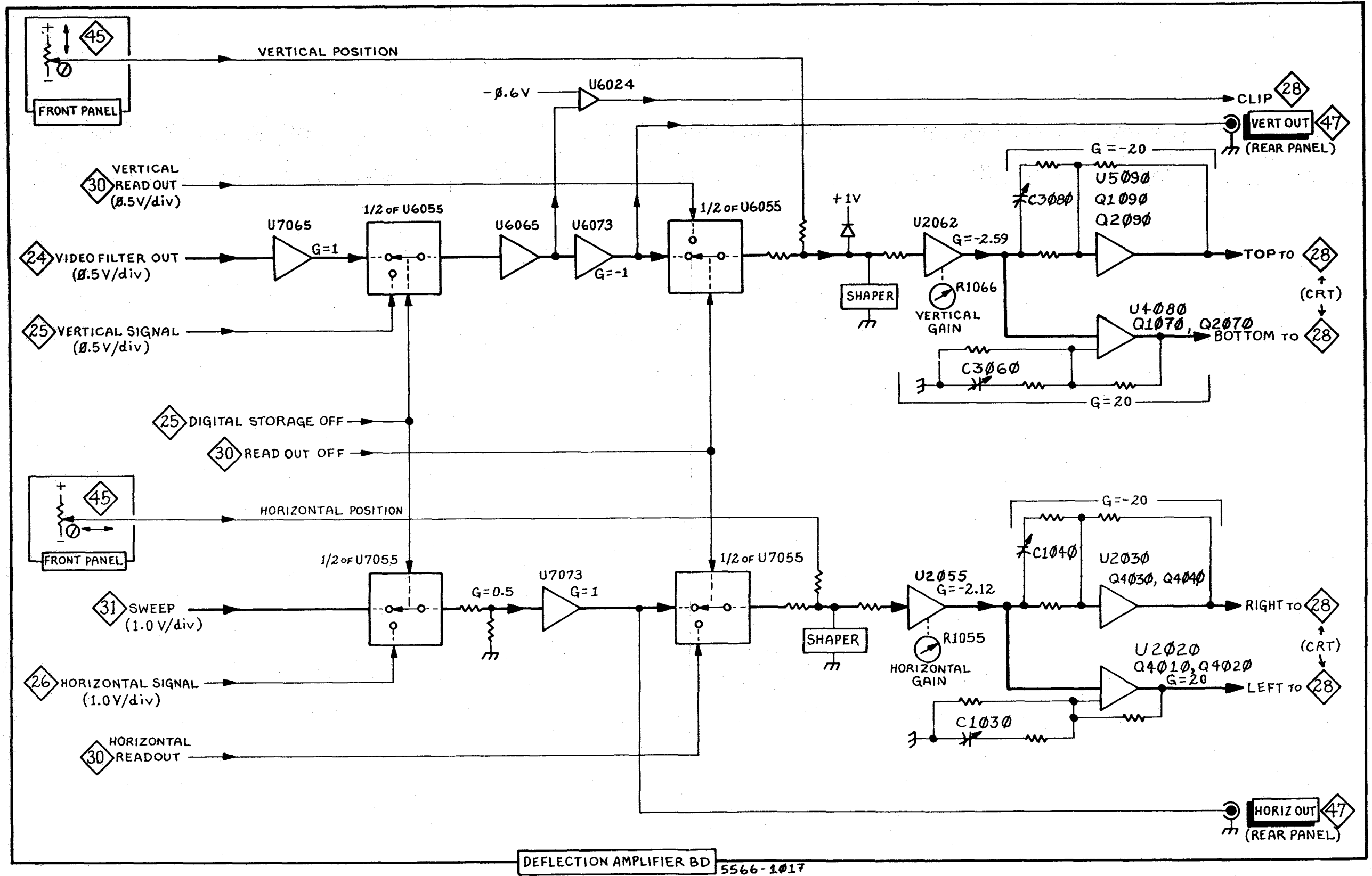

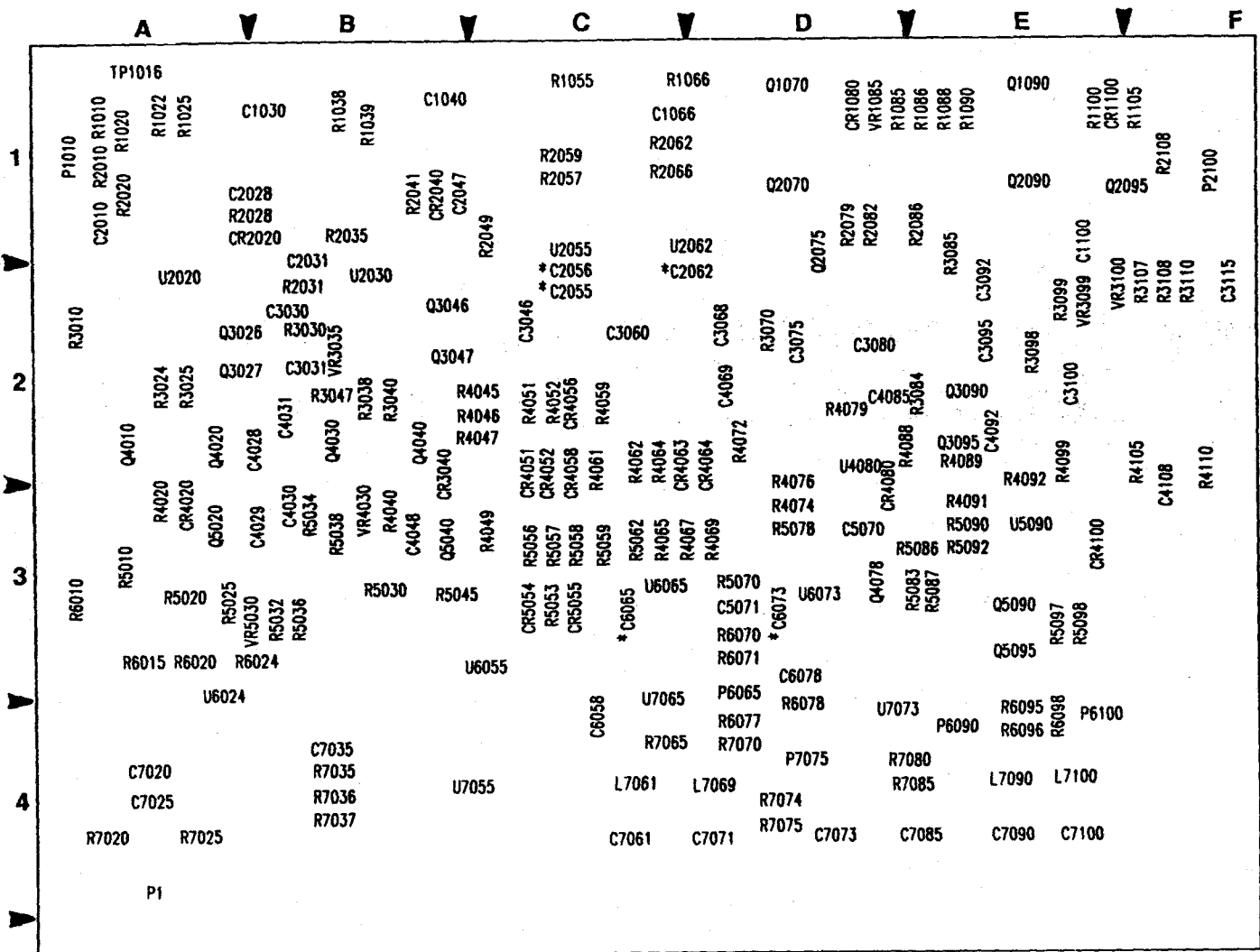

671-0372-

* DENOTE PARTS ON BACK OF BOARD

5566-1018

Figure 11-31A. A64A1—Deflection Amplifiers circuit board.

DEFLECTION AMPLIFIERS

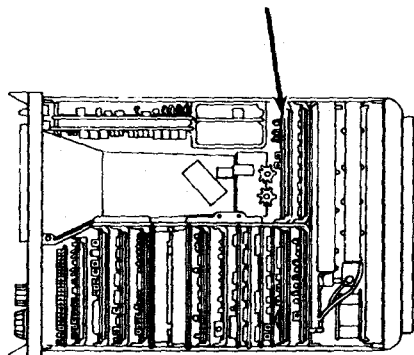

5566-609

A B C D E F G H

1
2
3
4
5

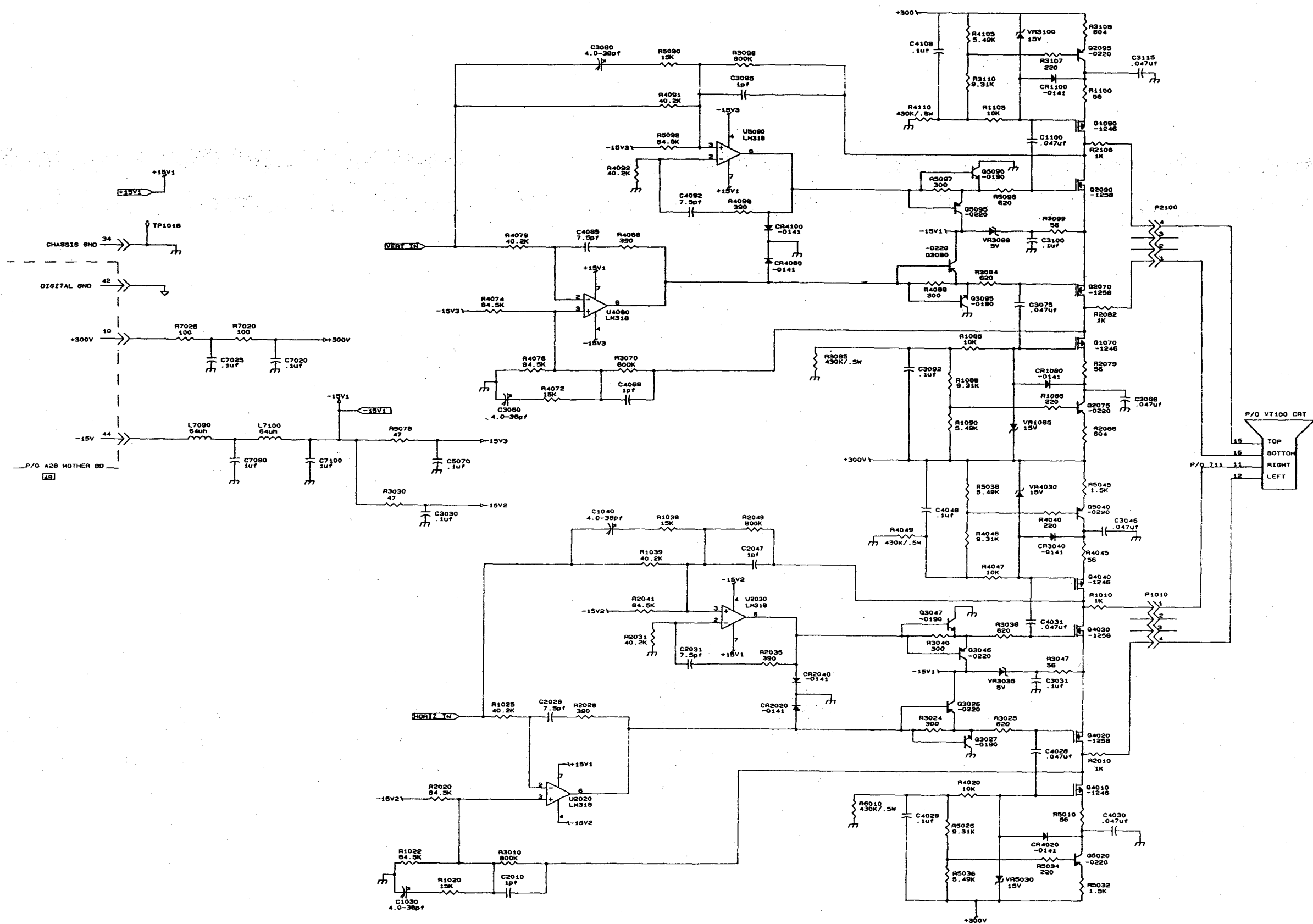

CHG/REF M63911

5566-1020

DEFLECTION AMPLIFIERS

DEFLECTION AMPLIFIERS

ASSEMBLY A64A1

CIRCUIT NUMBER	SCHEMATIC LOCATION	BOARD LOCATION	CIRCUIT NUMBER	SCHEMATIC LOCATION	BOARD LOCATION	CIRCUIT NUMBER	SCHEMATIC LOCATION	BOARD LOCATION
C1030	*C5	B1	Q3046	*F4	B2	R4099	*E2	E2
C1040	*D3	B1	Q3047	*F4	B2	R4105	*F1	F2
C1066	G2	C1	Q3090	*F2	E2	R4110	*F1	F2
C1100	*G1	E1	Q3095	*F2	E2	R5010	*G5	A3
C2010	*C5	A1	Q4010	*G5	A2	R5020	F2	A3
C2028	*D4	B1	Q4020	*G4	A2	R5025	*F5	A3
C2031	*F4	B2	Q4030	*G4	B2	R5030	E3	B3
C2047	*E4	B1	Q4040	*G4	B2	R5032	*F5	B3
C2055	H4	C2	Q4078	F3	D3	R5034	*F5	B3
C2056	H4	C2	Q5020	*F5	A3	R5036	*F5	B3
C2062	G2	C2	Q5040	*G3	B3	R5038	*F3	B3
C3030	*C3	B2	Q5090	*F1	E3	R5045	*G3	B3
C3031	*G4	B2	Q5095	*F2	E3	R5053	C1	C3
C3046	*G3	C2	R1010	*G4	A1	R5056	B5	C3
C3060	*C3	C2	R1020	*G5	A1	R5057	F5	C3
C3068	*G3	D2	R1022	*C5	A1	R5058	F5	C3
C3075	*F2	D2	R1025	*C4	A1	R5059	F4	C3
C3080	*D1	D2	R1038	*D3	B1	R5062	G4	C3
C3092	*F3	E2	R1039	*D4	B1	R5070	D1	D3
C3095	*E1	E2	R1055	H5	C1	R5078	*C3	D3
C3100	*F2	E2	R1066	G2	C1	R5083	F2	E3
C3115	*G1	F2	R1085	*F2	D1	R5086	B2	E3
C4028	*G5	A2	R1086	*G3	E1	R5087	F3	E3
C4029	*F5	B3	R1088	*F3	E1	R5090	*D1	E3
C4030	*G5	B3	R1090	*F3	E1	R5092	*D1	E3
C4031	*G4	B2	R1100	*G1	E1	R5097	*F2	E3
C4048	*F3	B3	R1105	*F1	F1	R5098	*F2	E3
C4069	*D3	D2	R2010	*G5	A1	R6010	*F5	A3
C4085	*D2	D2	R2020	*C5	A1	R6015	D3	A3
C4092	*E2	E2	R2028	*D4	A1	R6020	C1	A3
C4108	*F1	F3	R2031	*D4	B2	R6024	C1	A3
C5070	*C3	D3	R2035	*E4	B1	R6070	E1	D3
C5071	E1	D3	R2041	*D4	B1	R6071	D2	D3
C6058	B1	C4	R2049	*E3	C1	R6077	C2	D4
C6065	C2	C3	R2057	G4	C1	R6078	D2	D4
C6073	E2	D3	R2059	G5	C1	R6095	D4	E4
C6078	D2	D3	R2062	G2	C1	R6096	E3	E4
C7020	*B2	A4	R2066	G2	C1	R6098	D3	E4
C7025	*B2	A4	R2079	*G2	D1	R7020	*B2	A4
C7035	D1	B4	R2082	*G2	D1	R7025	*B2	A4
C7061	B5	C4	R2086	*G3	E1	R7035	D1	B4
C7071	B5	D4	R2108	*G1	F1	R7036	G3	B4
C7073	B5	D4	R3010	*C5	A2	R7037	C3	B4
C7085	B5	E4	R3024	*F4	A2	R7065	C4	C4
C7090	*B3	E4	R3025	*F4	A2	R7070	C4	D4
C7100	*B3	E4	R3030	*C3	B2	R7074	E1	D4
CR1080	*G3	D1	R3038	*F4	B2	R7075	A2	D4
CR1100	*G1	E1	R3040	*F4	B2	R7080	B5	D4
CR2020	*E4	A1	R3047	*G4	B2	R7085	B5	D4
CR2040	*E4	B1	R3070	*D2	D2	TP1016	*A2	A1
CR3040	*G3	B2	R3084	*F2	E2	U2020	*D5	A2
CR4020	*G5	A3	R3085	*E2	E2	U2030	*E4	B2
CR4051	G5	C2	R3098	*E1	E2	U2055	G4	C1
CR4052	G4	C2	R3099	*G2	E2	U2062	G2	C1
CR4056	G4	C2	R3107	*G1	F2	U4080	*D2	D2
CR4058	G4	C2	R3108	*G1	F2	U5090	*E1	E3
CR4063	G1	C2	R3110	*F1	F2	U6024	D1	A3
CR4064	G1	D2	R4020	*F5	A3	U6055	B2	C3
CR4080	*E2	D3	R4040	*G3	B3	U6055	F2	C3
CR4100	*E2	E3	R4045	*G3	C2	U6065	C2	C3
CR5054	D2	C3	R4046	*F3	C2	U6073	E2	D3
CR5055	C1	C3	R4047	*F4	C2	U7055	E4	B4
L7061	B5	C4	R4049	*F3	C3	U7055	AC4	B4
L7069	B5	D4	R4051	F4	C2	U7065	B2	C3
L7090	*B3	E4	R4052	G4	C2	U7073	D4	D4
L7100	*B3	E4	R4059	G4	C2	VR1085	*F3	D1
P1010	*G4	A1	R4061	G4	C2	VR3035	*F4	B2
P2100	*G2	F1	R4062	F2	C2	VR3099	*F2	B2
P6065	B1	D3	R4064	F2	C2	VR3100	*F1	E2
P6090	E4	E4	R4065	G1	C3	VR4030	*F3	B3
P6100	E3	E4	R4067	G1	C3	VR5030	*F5	A3
P7075	E1	D4	R4069	G1	D3			
Q1070	*G2	D1	R4072	*D3	D2			
Q1090	*G1	E1	R4074	*C2	D3			
Q2070	*G2	D1	R4076	*D2	D3			
Q2075	*G3	D1	R4079	*D2	D2			
Q2090	*G2	E1	R4088	*D2	D2			
Q2095	*G1	E1	R4089	*F2	E2			
Q3026	*F4	A2	R4091	*D1	E3			
Q3027	*F4	A2	R4092	*D1	E2			

* Locations are found on Deflection Amplifiers diagram 27B2

Manual Insert Status

<u>DATE</u>	<u>CHANGE REFERENCE</u>	<u>STATUS</u>
APR 1987	C10/487	Effective
APR 1987	M63532	Effective
SEP 1987	M63756	Effective
DEC 1987	M65465 REVISED	Effective
FEB 1988	M63911	Effective
APR 1988	M66557	Effective
MAY 1988	M66924	Effective
AUG 1988	M66071 REVISION	Effective
MAR 1989	M66829	Effective
JUL 1989	M66158 REV 3	Effective
MAY 1990	M67070	Effective
MAR 1991	M74739	Effective
APR 1991	M74861	Effective
APR 1991	M73913/M74682	Effective
FEB 1992	M75984	Effective
MAR 1992	M74824	Effective
MAR 1992	M74829	Effective
MAY 1992	M74825	Effective
MAY 1992	M76729	Effective
MAY 1992	M74827	Effective
JUL 1992	M74826	Effective
JUL 1992	M74828	Effective
AUG 1992	M76716	Effective
NOV 1992	M78348	Effective
NOV 1992	M76119	Effective
NOV 1992	M77545	Effective
NOV 1992	M78050	Effective
JAN 1993	M78375	Effective
JAN 1993	M78119	Effective
JAN 1993	M78875	Effective
JAN 1993	M69372	Effective
MAR 1993	M78527	Effective

Date: 4-8-87
Product: see listChange Reference: C10/487
Manual Part No.: see list

Product Group: 26

Instr.	Part No.
492A/492AP Service 2	070-5566-00
494/494P Service 2	070-4417-01
494A/494AP Service 2	070-5561-00
2754/2754P Service 2	070-6098-00
2755/2755P Service 2	070-6033-00
2765P Service 2	070-6319-00

ELECTRICAL PARTS LIST AND BLOCK DIAGRAM CHANGES

A 3dB fixed attenuator has been added to the L.O. input of the 1st converter.

REMOVE:

W118 175-2761-02 CABLE ASSY, RF:50 OHM COAX

ADD:

W117 174-0924-00 CABLE ASSY, RF:50 OHM COAX
A17 015-1053-01 ATTENUATOR, FXD:3dB PAD

The above parts are located on the RF Deck Interconnect diagram 11. Diagram's showing before and after the modification are on the following page.

RF Interconnect Diagram
(before Mod)

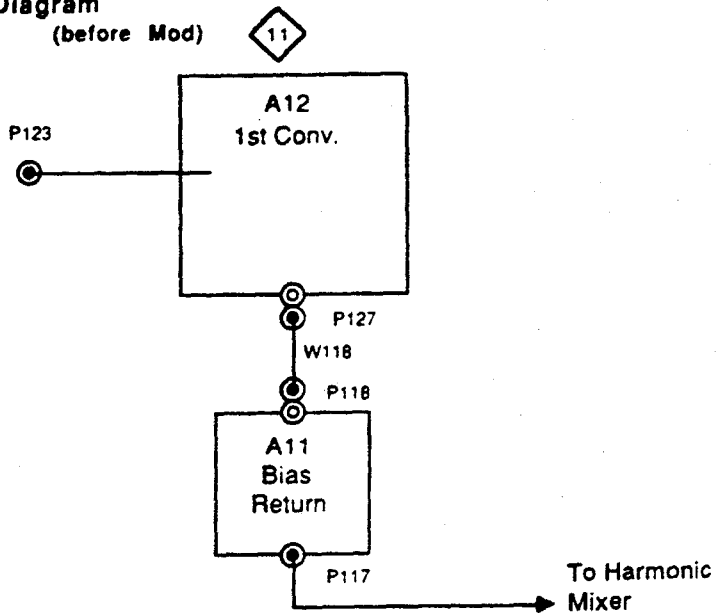

RF Interconnect Diagram
(after Mod)

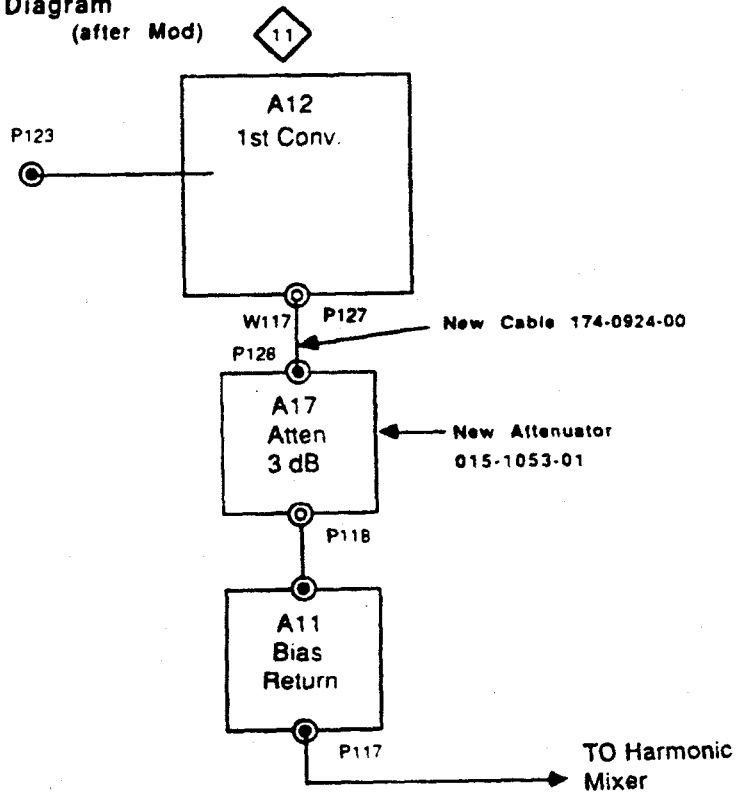

Date: 4/16/87

Change Reference: M63532

Product: see list

Manual Part No.: see list

Product Group: 26

Instr.	Part No.	E#/SN
492/492P Service 2	070-3784-01	SN B056106
492A/492AP Service 2	070-5566-00	SN B010488
495/495P Service 2	070-5085-00	SN B010211
496/496P Service 2	070-3482-00	SN B021830
492/492P Option 6	070-4233-00	SN B621830
494A/494AP Service 2	070-5561-00	SN B010114
2753/2753P Service 2	070-6307-00	SN B010109
2755/2755P Service 2	070-6033-00	SN B010249
2756P Service 2	070-6319-00	SN B010122

ELECTRICAL PARTS LIST AND SCHEMATIC CHANGES

CHANGE TO:

A19	119-1845-03	110MHZ IF ASSY: (OPTION 42 ONLY)
A191A	670-8650-03	110MHZ IF OUT ASSY: (OPTION 42 ONLY)
A19R12	321-5046-00	RES.,FXD,FILM:82.5 OHM,1%,0.125W
A19R14	321-5046-00	RES.,FXD,FILM:82.5 OHM,1%,0.125W
A19R16	321-5046-00	RES.,FXD,FILM:82.5 OHM,1%,0.125W

ADD:

L11	108-0262-00	COIL,RF:FIXED,505NH ON FORM
T11	120-1760-00	TRANSFORMER,2 TURN,BIFILAR
T13	120-1760-00	TRANSFORMER,2 TURN,BIFILAR
T15	120-1760-00	TRANSFORMER,2 TURN,BIFILAR

The above parts are located on the A19A1 110 MHz IF OUT CKT BD and shown on A19 110 MHz IF OUT ASSY, back of schematic 829 MHz 2ND CONVERTER 16

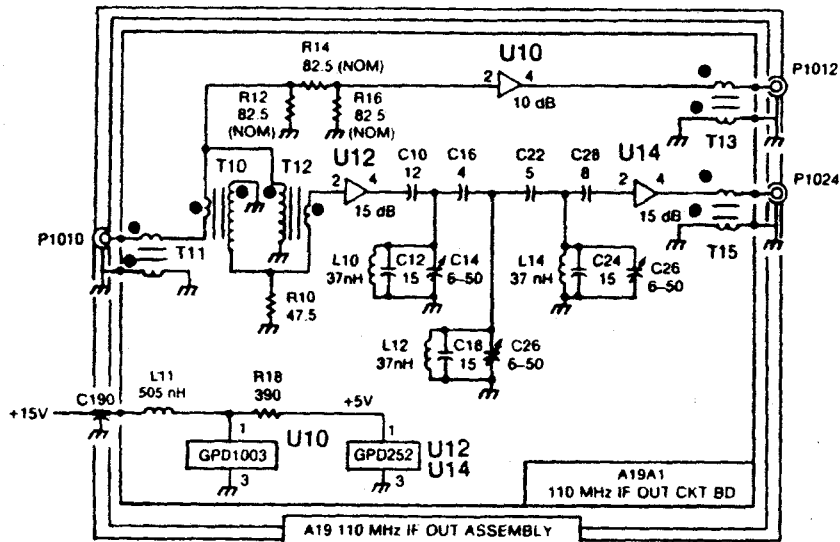

Date: 12-21-87
Product: See list

Change Reference: M65465 REVISED
Manual Part No: See list

Product Group: 26

INSTRUMENT	PART NO.	EFF/SN
492/P	070-3784-01	B056133
492/P OPT 6	070-4233-00	B621885
492A/P	070-5566-00	B010663
494A/P	070-5561-00	B010258, B010263, & B010274 and up
494/P	070-4417-01	B011155
495/P	070-5085-00	B020101
496/P	070-3482-00	B021885
2753P	070-6307-00	B020100
2754/P	070-6098-00	B010199
2755/P	070-6033-00	B010290
2756P	070-6319-00	B010198

ELECTRICAL PARTS LIST CHANGES

CHANGE TO:

A70	670-5557-03	CIRCUIT BD ASSY:Z-AXIS (492/P, 496/P & 492/P OPT 6 ONLY)
A70	670-9932-01	CIRCUIT BD ASSY:Z-AXIS (494A/P, 495/P, 2753P & 2756P ONLY)
A70	670-7919-04	CIRCUIT BD ASSY:Z-AXIS (492A/P, 494/P, 2754/P & 2755/P ONLY)

ADD:

A70CR3028 152-0141-02 SEMICON DVC,DI,SW,SI,30V,150MA,DO-35

INSTALL ON BACK OF BOARD CR3028 (152-0141-02) BETWEEN EMITTER-COLLECTOR POINTS OF Q3028, WITH THE CATHODE OF THE DIODE GOING TO THE EMITTER AND THE ANODE GOING TO THE COLLECTOR.

Date: 2-22-88
Product: see list

Change Reference: M63911
Manual Part No: see list

Product Group: 26

Instrument	Manual	Eff/SN
492/P service 2	070-3784-01	B056139
492/P 6 service 2	070-4233-00	B621912
494/P service 2	070-4417-01	B011156
495/P service 2	070-5085-00	B020228
496/P service 2	070-3482-00	B021912
492A/AP service 2	070-5566-01	B010702
494A/AP service 2	070-5561-00	B010383

Electrical Parts List

Change to:

<u>Component No.</u>	<u>Part No.</u>	<u>Name & Description</u>
A64	672-0162-03	CIRCUIT BD ASSY:DEFLECTION AMP
A64A1	671-0372-00	CIRCUIT BD ASSY:DEFLECTION AMP
A64A1C1030	281-0226-00	CAP,VAR,PLASTIC:5.5-65PF,100V
A64A1C1040	281-0226-00	CAP,VAR,PLASTIC:5.5-65PF,100V
A64A1C1066	283-0158-00	CAP,FXD,CER DI: 1PF,+/-0.1PF,50V
A64A1C1100	283-0187-00	CAP,FXD,CER DI:0.047UF,10%,400
A64A1C2010	281-0538-00	CAP,FXD,CER DI:1PF,20%,500V
A64A1C2028	281-0898-00	CAP,FXD,CER DI:7.5PF,+/-0.5PF,500V
A64A1C2031	281-0898-00	CAP,FXD,CER DI:7.5PF,+/-0.5PF,500V
A64A1C2047	281-0538-00	CAP,FXD,CER DI:1PF,20%,500V
A64A1C2055	283-0167-00	CAP,FXD,CER DI:0.1UF,10%,100V
A64A1C2056	283-0330-00	CAP,FXD,CER DI:100PF,5%50V
A64A1C2062	283-0167-00	CAP,FXD,CER DI:0.1UF,10%,100V
A64A1C3030	283-0167-00	CAP,FXD,CER DI:0.1UF,10%,100V
A64A1C3031	283-0167-00	CAP,FXD,CER DI:0.1UF,10%,100V
A64A1C3046	283-0187-00	CAP,FXD,CER DI:0.047UF,10%,400
A64A1C3060	281-0226-00	CAP,VAR,PLASTIC:5.5-65PF,100V
A64A1C3068	283-0187-00	CAP,FXD,CER DI:0.047UF,10%,400
A64A1C3075	283-0187-00	CAP,FXD,CER DI:0.047UF,10%,400
A64A1C3080	281-0226-00	CAP,VAR,PLASTIC:5.5-65PF,100V
A64A1C3092	283-0167-00	CAP,FXD,CER DI:0.1UF,10%,100V
A64A1C3095	281-0538-00	CAP,FXD,CER DI:1PF,20%,500V
A64A1C3100	281-0538-00	CAP,FXD,CER DI:1PF,20%,500V
A64A1C3115	283-0187-00	CAP,FXD,CER DI:0.047UF,10%,400
A64A1C4028	283-0187-00	CAP,FXD,CER DI:0.047UF,10%,400
A64A1C4029	283-0167-00	CAP,FXD,CER DI:0.1UF,10%,100V
A64A1C4030	283-0187-00	CAP,FXD,CER DI:0.047UF,10%,400
A64A1C4031	283-0187-00	CAP,FXD,CER DI:0.047UF,10%,400
A64A1C4048	283-0167-00	CAP,FXD,CER DI:0.1UF,10%,100V
A64A1C4085	281-0898-00	CAP,FXD,CER DI:7.5PF,+/-0.5PF,500V
A64A1C4092	281-0898-00	CAP,FXD,CER DI:7.5PF,+/-0.5PF,500V
A64A1C4096	281-0538-00	CAP,FXD,CER DI:1PF,20%,500V
A64A1C4108	283-0167-00	CAP,FXD,CER DI:0.1UF,10%,100V
A64A1C5070	283-0167-00	CAP,FXD,CER DI:0.1UF,10%,100V
A64A1C5071	281-0811-00	CAP,FXD,CER DI:10.PF,10%,100V
A64A1C6058	283-0167-00	CAP,FXD,CER DI:0.1UF,10%,100V

<u>Component No.</u>	<u>Part No.</u>	<u>Name & Description</u>
A64A1C6065	283-0167-00	CAP,FXD,CER DI:0.1UF,10%,100V
A64A1C6073	283-0167-00	CAP,FXD,CER DI:0.1UF,10%,100V
A64A1C6078	283-0181-00	CAP,FXD,CER DI:1.8PF,+/-0.1%,100V
A64A1C7020	283-0189-00	CAP,FXD,CER DI:1UF,20%,400V
A64A1C7025	283-0189-00	CAP,FXD,CER DI:1UF,20%,400V
A64A1C7035	283-0065-00	CAP,FXD,CER DI:001UF,5%,100V
A64A1C7061	283-0177-00	CAP,FXD,CER DI:1UF,+80-20%,25V
A64A1C7071	283-0177-00	CAP,FXD,CER DI:1UF,+80-20%,25V
A64A1C7073	283-0177-00	CAP,FXD,CER DI:1UF,+80-20%,25V
A64A1C7085	283-0177-00	CAP,FXD,CER DI:1UF,+80-20%,25V
A64A1C7090	283-0177-00	CAP,FXD,CER DI:1UF,+80-20%,25V
A64A1C7100	283-0177-00	CAP,FXD,CER DI:1UF,+80-20%,25V
A64A1CR1080	152-0141-02	SEMICON DVC, DI:SW,SI,30V,1500MA,DO-35
A64A1CR1100	152-0141-02	SEMICON DVC, DI:SW,SI,30V,1500MA,DO-35
A64A1CR2020	152-0141-02	SEMICON DVC, DI:SW,SI,30V,1500MA,DO-35
A64A1CR2040	152-0141-02	SEMICON DVC, DI:SW,SI,30V,1500MA,DO-35
A64A1CR3040	152-0141-02	SEMICON DVC, DI:SW,SI,30V,1500MA,DO-35
A64A1CR4020	152-0141-02	SEMICON DVC, DI:SW,SI,30V,1500MA,DO-35
A64A1CR4051	152-0141-02	SEMICON DVC, DI:SW,SI,30V,1500MA,DO-35
A64A1CR4052	152-0141-02	SEMICON DVC, DI:SW,SI,30V,1500MA,DO-35
A64A1CR4056	152-0141-02	SEMICON DVC, DI:SW,SI,30V,1500MA,DO-35
A64A1CR4058	152-0141-02	SEMICON DVC, DI:SW,SI,30V,1500MA,DO-35
A64A1CR4063	152-0141-02	SEMICON DVC, DI:SW,SI,30V,1500MA,DO-35
A64A1CR4064	152-0141-02	SEMICON DVC, DI:SW,SI,30V,1500MA,DO-35
A64A1CR4080	152-0141-02	SEMICON DVC, DI:SW,SI,30V,1500MA,DO-35
A64A1CR4100	152-0141-02	SEMICON DVC, DI:SW,SI,30V,1500MA,DO-35
A64A1CR5054	152-0141-02	SEMICON DVC, DI:SW,SI,30V,1500MA,DO-35
A64A1CR5055	152-0141-02	SEMICON DVC, DI:SW,SI,30V,1500MA,DO-35
A64A1L7061	108-0395-00	COIL,RF:FIXED,646H
A64A1L7069	108-0395-00	COIL,RF:FIXED,646H
A64A1L7090	108-0395-00	COIL,RF:FIXED,646H
A64A1L7100	108-0395-00	COIL,RF:FIXED,646H
A64A1Q1070	151-1246-00	TRANS,PWR MOSFET, P CHAN, 400V,10-220
A64A1Q1090	151-1246-00	TRANS,PWR MOSFET, P CHAN, 400V,10-220
A64A1Q4010	151-1246-00	TRANS,PWR MOSFET, P CHAN, 400V,10-220
A64A1Q4040	151-1246-00	TRANS,PWR MOSFET, P CHAN, 400V,10-220
A64A1Q2070	151-1258-00	TRANS,PWR MOSFET, N CHAN, 400V,10-220
A64A1Q2075	151-0220-00	TRANS:PNP,SI,TO-92
A64A1Q2090	151-1258-00	TRANS,PWR MOSFET, N CHAN, 400V,10-220
A64A1Q2095	151-0220-00	TRANS:PNP,SI,TO-92
A64A1Q3026	151-0220-00	TRANS:PNP,SI,TO-92
A64A1Q3027	151-0190-00	TRANS:NPN,SI,TO-92
A64A1Q3046	151-0220-00	TRANS:PNP,SI,TO-92
A64A1Q3047	151-0190-00	TRANS:NPN,SI,TO-92
A64A1Q3090	151-0220-00	TRANS:PNP,SI,TO-92
A64A1Q3095	151-0190-00	TRANS:NPN,SI,TO-92
A64A1Q4020	151-1258-00	TRANS,PWR MOSFET, N CHAN, 400V,10-220
A64A1Q4030	151-1258-00	TRANS,PWR MOSFET, N CHAN, 400V,10-220
A64A1Q4078	151-0220-00	TRANS:PNP,SI,TO-92
A64A1Q5020	151-0220-00	TRANS:PNP,SI,TO-92
A64A1Q5040	151-0220-00	TRANS:PNP,SI,TO-92
A64A1Q5090	151-0190-00	TRANS:NPN,SI,TO-92
A64A1Q5095	151-0220-00	TRANS:PNP,SI,TO-92
A64A1R1010	315-0102-00	RES,FXD,FILM:1K OHM,5%,0.25W
A64A1R1020	315-0153-00	RES,FXD,FILM:15K OHM,5%,0.25W MI
A64A1R1022	321-0378-00	RES,FXD,FILM:84.5K OHM,1%,0.125W TC=TO
A64A1R1025	321-0347-00	RES,FXD,FILM:40.2K OHM,1%,0.125W TC=TO

<u>Component No.</u>	<u>Part No.</u>	<u>Name & Description</u>
A64A1R1038	315-0153-00	RES,FXD,FILM:15K OHM,5%,0.25W MI
A64A1R1039	321-0347-00	RES,FXD,FILM:40.2K OHM,1%,0.125W TC=TO
A64A1R1055	311-1245-00	RES,VAR,NONWW:TRMR,10K OHM,0.5W
A64A1R1066	311-1245-00	RES,VAR,NONWW:TRMR,10K OHM,0.5W
A64A1R1085	315-0103-00	RES,FXD,FILM:10K OHM,5%,0.25W
A64A1R1086	315-0221-00	RES,FXD,FILM:220 OHM,5%,0.25W MI
A64A1R1088	321-0286-00	RES,FXD,FILM:9.31K OHM,1%,0.125W TC=TO
A64A1R1090	321-0264-00	RES,FXD,FILM:5.49K OHM,1%,0.125W TC=TO
A64A1R1100	315-0560-00	RES,FXD,FILM:560 OHM,5%,0.25W MI
A64A1R1105	315-0103-00	RES,FXD,FILM:10K OHM,5%,0.25W
A64A1R2010	315-0102-00	RES,FXD,FILM:1K OHM,5%,0.25W
A64A1R2020	321-0378-00	RES,FXD,FILM:84.5K OHM,1%,0.125W TC=TO
A64A1R2028	315-0391-00	RES,FXD,FILM:390 OHM,5%,0.25W MI
A64A1R2031	321-0347-00	RES,FXD,FILM:40.2K OHM,1%,0.125W TC=TO
A64A1R2035	315-0391-00	RES,FXD,FILM:390 OHM,5%,0.25W MI
A64A1R2041	321-0378-00	RES,FXD,FILM:84.5K OHM,1%,0.125W TC=TO
A64A1R2049	321-0620-00	RES,FXD,FILM:800K OHM,1%,0.5M TC=TO
A64A1R2057	321-0372-00	RES,FXD,FILM:73.2K OHM,1%,0.125W TC=TO
A64A1R2059	321-0415-00	RES,FXD,FILM:205K OHM,1%,0.125W TC=TO
A64A1R2062	321-0409-00	RES,FXD,FILM:178K OHM,1%,0.125W TC=TO
A64A1R2066	321-0382-00	RES,FXD,FILM:93.1K OHM,1%,0.125W TC=TO
A64A1R2079	315-0560-00	RES,FXD,FILM:560 OHM,5%,0.25W MI
A64A1R2082	315-0102-00	RES,FXD,FILM:1K OHM,5%,0.25W
A64A1R2086	321-0172-00	RES,FXD,FILM:604 OHM,1%,0.125W TC=TO
A64A1R2108	315-0102-00	RES,FXD,FILM:1K OHM,5%,0.25W
A64A1R3010	321-0620-00	RES,FXD,FILM:800K OHM,1%,0.5M TC=TO
A64A1R3024	315-0301-00	RES,FXD,FILM:300 OHM,5%,0.25W MI
A64A1R3025	315-0621-00	RES,FXD,FILM:620 OHM,5%,0.25W MI
A64A1R3030	315-0470-00	RES,FXD,FILM:47 OHM,5%,0.25W
A64A1R3038	315-0621-00	RES,FXD,FILM:620 OHM,5%,0.25W MI
A64A1R3040	315-0301-00	RES,FXD,FILM:300 OHM,5%,0.25W MI
A64A1R3047	315-0560-00	RES,FXD,FILM:560 OHM,5%,0.25W MI
A64A1R3070	321-0620-00	RES,FXD,FILM:800K OHM,1%,0.5M TC=TO
A64A1R3084	315-0621-00	RES,FXD,FILM:620 OHM,5%,0.25W MI
A64A1R3085	301-0434-00	RES,FXD,FILM:430K OHM,5%,0.5W
A64A1R3099	315-0560-00	RES,FXD,FILM:560 OHM,5%,0.25W MI
A64A1R3107	315-0221-00	RES,FXD,FILM:220 OHM,5%,0.25W MI
A64A1R3108	321-0172-00	RES,FXD,FILM:604 OHM,1%,0.125W TC=TO
A64A1R3110	321-0286-00	RES,FXD,FILM:9.31K OHM,1%,0.125W TC=TO
A64A1R4020	315-0103-00	RES,FXD,FILM:10K OHM,5%,0.25W
A64A1R4040	315-0221-00	RES,FXD,FILM:220 OHM,5%,0.25W MI
A64A1R4045	315-0560-00	RES,FXD,FILM:560 OHM,5%,0.25W MI
A64A1R4046	321-0286-00	RES,FXD,FILM:9.31K OHM,1%,0.125W TC=TO
A64A1R4047	315-0103-00	RES,FXD,FILM:10K OHM,5%,0.25W
A64A1R4049	301-0434-00	RES,FXD,FILM:430K OHM,5%,0.5W
A64A1R4051	321-0286-00	RES,FXD,FILM:9.31K OHM,1%,0.125W TC=TO
A64A1R4052	321-0318-00	RES,FXD,FILM:20.0K OHM,1%,0.125W TC=TO
A64A1R4059	321-0379-00	RES,FXD,FILM:86.6K OHM,1%,0.125W TC=TO
A64A1R4061	321-0280-00	RES,FXD,FILM:8.06K OHM,1%,0.125W TC=TO
A64A1R4062	321-0286-00	RES,FXD,FILM:9.31K OHM,1%,0.125W TC=TO
A64A1R4064	321-0318-00	RES,FXD,FILM:20.0K OHM,1%,0.125W TC=TO
A64A1R4065	321-0416-00	RES,FXD,FILM:210K OHM,1%,0.125W TC=TO
A64A1R4067	321-0282-00	RES,FXD,FILM:8.45K OHM,1%,0.125W TC=TO
A64A1R4069	321-0416-00	RES,FXD,FILM:210K OHM,1%,0.125W TC=TO
A64A1R4072	315-0153-00	RES,FXD,FILM:15K OHM,5%,0.25W MI
A64A1R4074	321-0378-00	RES,FXD,FILM:84.5K OHM,1%,0.125W TC=TO
A64A1R4076	321-0378-00	RES,FXD,FILM:84.5K OHM,1%,0.125W TC=TO

<u>Component No.</u>	<u>Part No.</u>	<u>Name & Description</u>
A64A1R4079	321-0347-00	RES,FXD,FILM:40.2K OHM,1%,0.125W TC=TO
A64A1R4088	315-0391-00	RES,FXD,FILM:390 OHM,5%,0.25W MI
A64A1R4089	315-0301-00	RES,FXD,FILM:300 OHM,5%,0.25W MI
A64A1R4091	321-0347-00	RES,FXD,FILM:40.2K OHM,1%,0.125W TC=TO
A64A1R4092	321-0347-00	RES,FXD,FILM:40.2K OHM,1%,0.125W TC=TO
A64A1R4099	315-0391-00	RES,FXD,FILM:390 OHM,5%,0.25W MI
A64A1R4105	321-0264-00	RES,FXD,FILM:5.49K OHM,1%,0.125W TC=TO
A64A1R4110	301-0434-00	RES,FXD,FILM:430K OHM,5%,0.5W
A64A1R5010	315-0560-00	RES,FXD,FILM:560 OHM,5%,0.25W MI
A64A1R5020	311-1245-00	RES,VAR,NONWW:TRMR,10K OHM,0.5W
A64A1R5025	321-0286-00	RES,FXD,FILM:9.31K OHM,1%,0.125W TC=TO
A64A1R5030	311-1245-00	RES,VAR,NONWW:TRMR,10K OHM,0.5W
A64A1R5032	321-0210-00	RES,FXD,FILM:1.50K OHM,1%,0.125W TC=TO
A64A1R5034	315-0221-00	RES,FXD,FILM:220 OHM,5%,0.25W MI
A64A1R5036	321-0264-00	RES,FXD,FILM:5.49K OHM,1%,0.125W TC=TO
A64A1R5038	321-0264-00	RES,FXD,FILM:5.49K OHM,1%,0.125W TC=TO
A64A1R5045	321-0210-00	RES,FXD,FILM:1.50K OHM,1%,0.125W TC=TO
A64A1R5053	321-0335-00	RES,FXD,FILM:30.1K OHM,1%,0.125W TC=TO
A64A1R5056	321-0424-00	RES,FXD,FILM:255K OHM,1%,0.125W TC=TO
A64A1R5057	321-0412-00	RES,FXD,FILM:191K OHM,1%,0.125W TC=TO
A64A1R5058	321-0215-00	RES,FXD,FILM:1.69K OHM,1%,0.125W TC=TO
A64A1R5059	321-0412-00	RES,FXD,FILM:191K OHM,1%,0.125W TC=TO
A64A1R5062	321-0379-00	RES,FXD,FILM:86.6K OHM,1%,0.125W TC=TO
A64A1R5070	321-0420-00	RES,FXD,FILM:232K OHM,1%,0.125W TC=TO
A64A1R5078	315-0470-00	RES,FXD,FILM:47 OHM,5%,0.25W
A64A1R5083	321-0398-00	RES,FXD,FILM:137K OHM,1%,0.125W TC=TO
A64A1R5086	321-0424-00	RES,FXD,FILM:255K OHM,1%,0.125W TC=TO
A64A1R5087	321-0285-00	RES,FXD,FILM:9.09K OHM,1%,0.125W TC=TO
A64A1R5090	315-0153-00	RES,FXD,FILM:15K OHM,5%,0.25W MI
A64A1R5092	321-0378-00	RES,FXD,FILM:84.5K OHM,1%,0.125W TC=TO
A64A1R5097	315-0301-00	RES,FXD,FILM:300 OHM,5%,0.25W MI
A64A1R5098	315-0621-00	RES,FXD,FILM:620 OHM,5%,0.25W MI
A64A1R6010	301-0434-00	RES,FXD,FILM:430K OHM,5%,0.5W
A64A1R6015	315-0104-00	RES,FXD,FILM:100K OHM,5%,0.25W
A64A1R6020	321-0439-00	RES,FXD,FILM:365K OHM,1%,0.125W TC=TO
A64A1R6024	321-0338-00	RES,FXD,FILM:32.4K OHM,1%,0.125W TC=TO
A64A1R6065	315-0102-00	RES,FXD,FILM:1K OHM,5%,0.25W
A64A1R6070	321-0335-00	RES,FXD,FILM:30.1K OHM,1%,0.125W TC=TO
A64A1R6071	321-0335-00	RES,FXD,FILM:30.1K OHM,1%,0.125W TC=TO
A64A1R6077	321-0335-00	RES,FXD,FILM:30.1K OHM,1%,0.125W TC=TO
A64A1R6078	321-0335-00	RES,FXD,FILM:30.1K OHM,1%,0.125W TC=TO
A64A1R6096	315-0102-00	RES,FXD,FILM:1K OHM,5%,0.25W
A64A1R6098	315-0202-00	RES,FXD,FILM:2K OHM,5%,0.25W MI
A64A1R7020	315-0101-00	RES,FXD,FILM:1K OHM,5%,0.25W
A64A1R7025	315-0101-00	RES,FXD,FILM:1K OHM,5%,0.25W
A64A1R7035	315-0512-00	RES,FXD,FILM:5.1K OHM,5%,0.25W
A64A1R7036	315-0512-00	RES,FXD,FILM:5.1K OHM,5%,0.25W
A64A1R7037	315-0512-00	RES,FXD,FILM:5.1K OHM,5%,0.25W
A64A1R7065	321-0335-00	RES,FXD,FILM:30.1K OHM,1%,0.125W TC=TO
A64A1R7070	321-0335-00	RES,FXD,FILM:30.1K OHM,1%,0.125W TC=TO
A64A1R7074	315-0102-00	RES,FXD,FILM:1K OHM,5%,0.25W
A64A1R7075	315-0104-00	RES,FXD,FILM:100K OHM,5%,0.25W
A64A1R7080	315-0100-00	RES,FXD,FILM:10 OHM,5%,0.25W
A64A1R7085	315-0100-00	RES,FXD,FILM:10 OHM,5%,0.25W
A64A1U2020	156-0742-02	MICROCKT,LINEAR:OPNL AMPL,SELECTED
A64A1U2030	156-0742-02	MICROCKT,LINEAR:OPNL AMPL,SELECTED
A64A1U2055	156-0742-02	MICROCKT,LINEAR:OPNL AMPL,SELECTED

<u>Component No.</u>	<u>Part No.</u>	<u>Name & Description</u>
A64A1U2062	156-0742-02	MICROCKT,LINEAR:OPNL AMPL,SELECTED
A64A1U4080	156-0742-02	MICROCKT,LINEAR:OPNL AMPL,SELECTED
A64A1U5090	156-0742-02	MICROCKT,LINEAR:OPNL AMPL,SELECTED
A64A1U6024	156-1226-01	MICROCKT,LINEAR:DUAL COMPARATOR,SCRN
A64A1U6055	156-1211-00	MICROCKT,INTFC:QUAD SPST SWITCH,2NC,2NO
A64A1U6065	156-0742-02	MICROCKT,LINEAR:OPNL AMPL,SELECTED
A64A1U6073	156-0742-02	MICROCKT,LINEAR:OPNL AMPL,SELECTED
A64A1U7055	156-0742-02	MICROCKT,LINEAR:OPNL AMPL,SELECTED
A64A1U7065	156-0742-02	MICROCKT,LINEAR:OPNL AMPL,SELECTED
A64A1U7073	156-0158-04	MICROCKT,LINEAR:DUAL OPNL AMPL
A64A1VR1085	152-0243-00	SEMICON DVC,DI,ZEN,SI,15V,5%,0.4W,DO-7
A64A1VR3035	152-0279-00	SEMICON DVC,DI,ZEN,SI,5.1V,5%,0.4W,DO-7
A64A1VR3099	152-0279-00	SEMICON DVC,DI,ZEN,SI,5.1V,5%,0.4W,DO-7
A64A1VR3100	152-0243-00	SEMICON DVC,DI,ZEN,SI,15V,5%,0.4W,DO-7
A64A1VR4030	152-0243-00	SEMICON DVC,DI,ZEN,SI,15V,5%,0.4W,DO-7
A64A1VR5030	152-0243-00	SEMICON DVC,DI,ZEN,SI,15V,5%,0.4W,DO-7

MECHANICAL PARTS LIST

CHANGE TO:

5-210	200-2238-02	CIRCUIT BD COVER:DEFLECTION AMP.
5-215	210-0054-00	WASHER LOCK#4:SPLIT, .025
4-141	342-0507-00	INSULATOR PLATE:HIGH VOLTAGE

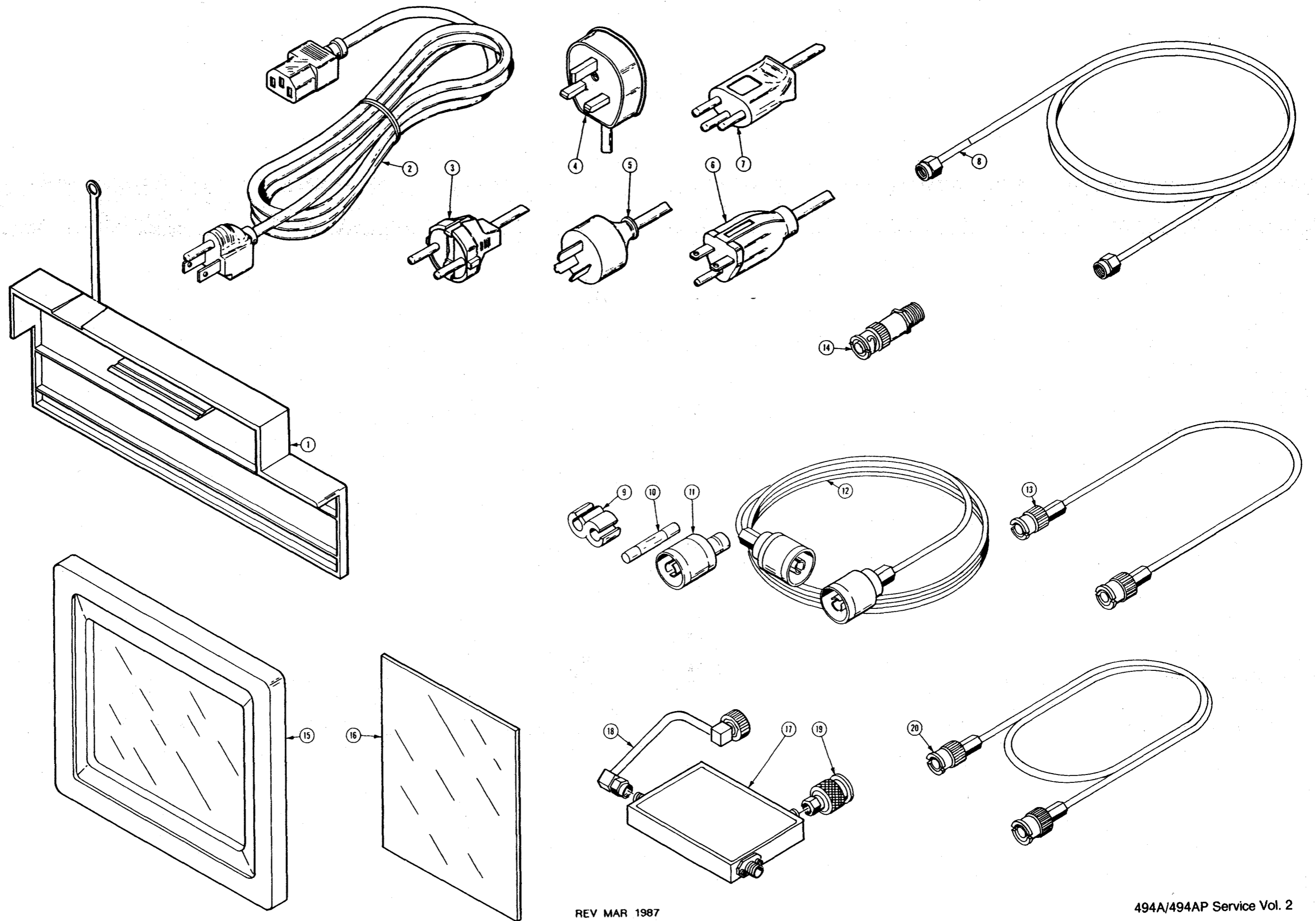

REV MAR 1987

Replaceable Mechanical Parts
494A/494AP Service Vol.2

Fig. & Index No.	Tektronix Part No.	Serial/Assembly No.		Qty	12345	Name & Description	Mfr.	
		Effective	Discont				Code	Mfr. Part No.
10-1	333-3373-00			1		PANEL,FRONT: (494A OPTION 07 ONLY)	80009	333-3373-00
	333-3375-00			1		PANEL,FRONT: (494AP OPTION 07 ONLY)	80009	333-3375-00
	333-3374-00			1		PANEL,FRONT: (494A OPTION 08 ONLY)	80009	333-3374-00
	333-3376-00			1		PANEL,FRONT: (494AP OPTION 08 ONLY)	80009	333-3376-00
-2	-----			1		TRANSFORMER,RF:(SEE T200 REPL)		
-3	-----			1		CABLE ASSY,RF:(SEE W700 REPL)		
-4	-----			1		CABLE ASSY,RF:(SEE W702 REPL)		
-5	-----			1		CABLE ASSY,RF:(SEE W701 REPL)		
-6	-----			1		CABLE ASSY,RF:(SEE W125 REPL) (OPTION 08 ONLY)		
-7	-----			1		CABLE ASSY,RF:(SEE W703 REPL)		
-8	407-3237-00			1		RELAY ASSY:(SEE A34A3 REPL)		
-9	211-0008-00			1		BRACKET,CKT BD: (ATTACHING PARTS)	80009	407-3237-00
-10	-----			4		.SCREW,MACHINE:4-40 X 0.25,PNH,STL (END ATTACHING PARTS)	93907	ORDER BY DESCR
-11	211-0008-00			1		.CKT BOARD ASSY:(SEE A34A3A1) (ATTACHING PARTS)		
-12	210-0992-00			2		.SCREW,MACHINE:4-40 X 0.25,PNH,STL (END ATTACHING PARTS)	93907	ORDER BY DESCR
-13	-----			1		.CKT BOARD ASSY INCLUDES: .WASHER,FLAT:0.265 ID X 0.437 OD X 0.01	80009	210-0992-00
-14	210-0407-00			1		.CAP,FXD,CER D1:(SEE A34A3C325) (ATTACHING PARTS)		
-15	210-0006-00			1		.NUT,PLAIN,HEX:6-32 X 0.25,BRS CD PL	73743	3038-402
-16	334-6078-00			1		.WASHER,LOCK:#6 INTL,0.018 THK,STL (END ATTACHING PARTS)	77900	1206-00-00-0541C
-17	131-0938-00			1		.MARKER,IDENT:MKD BLANK	80009	334-6078-00
-18	380-0741-00			1		.CONN,RF JACK::SMB/PNL,;MALE,STR,50 OHM,0.25 .HEX,2.0 L 0.025 DIA TAIL,10-32 THD,REAR MT	24931	32JR125-1
-19	-----			1		.HOUSING,CKT BD:ALUMINUM CABLE ASSY,RF:(SEE W341 REPL)	80009	380-0741-00

Replaceable Mechanical Parts
494A/494AP Service Vol.2

Fig. & Index No.	Tektronix Part No.	Serial/Assembly No. Effective	Discont	Qty	12345 Name & Description	Mfr. Code	Mfr. Part No.
11-1	337-3274-00			1	SHIELD,ELEC:CONN,POLYAMIDE	80009	337-3274-00
-2	161-0104-00			1	CABLE ASSY,PWR,:3,18 AWG,98 L,SVT,GREY/BLK,60 DEG C,BME X RTANG IEC,RECP,10A/250V;,,	16428	CH8352, FH-8352
-3	161-0132-00			1	CABLE ASSY,PWR,:3,1.0MM SQ,250V,3.05M L,10A,EUROPEAN (OPTION A1 EUROPEAN ONLY)	80009	161-0132-00
-4	161-0104-07			1	CABLE ASSY,PWR,: (OPTION A2 UNITED KINGDOM ONLY)	80009	161-0104-07
-5	161-0135-00	B010100	B020680	1	CABLE ASSY,PWR,:3,1.0MM SQ,250V,3.05M L,10A,AUSTRALIAN	80009	161-0135-00
	161-0104-05	B020681		1	CABLE ASSY,PWR,:3,18 AWG,240V,98.0 L (OPTION A3 AUSTRALIAN ONLY)	S3109	
-6	161-0134-00			1	CABLE ASSY,PWR,:3,18 AWG,240V,120.0 L (OPTION A4 NORTH AMERICAN ONLY)	70903	ORDER BY DESCR
-7	161-0167-00			1	CABLE ASSY,PWR,:3.0 X 0.75,6A,240V,2.5M L (OPTION A5 SWISS ONLY)	80009	161-0167-00
-8	012-0649-00			1	CABLE ASSY,RF:50 OHM COAX,28.5 L	19505	80-9902-201
-9	343-0170-00			1	RTNR,CA TO CA:U/W 0.25 OD CABLES	80009	343-0170-00
-10	159-0017-00			2	FUSE,CARTRIDGE:3AG,4A,250V,FAST BLOW	71400	AGC-4
-11	103-0045-00			1	ADAPTER,CONN:N MALE TO BNC FEMALE	24931	29 JP104-3
-12	012-0114-00			1	CABLE ASSY,RF:50 OHM COAX,72.0 L	91836	K-3802
-13	012-0076-00			1	CABLE ASSY,RF:50 OHM COAX,20.0 L	80009	012-0076-00
-14	013-0126-00			1	ADAPTER,CONN:BNC TO F	80009	013-0126-00
-15	378-0227-01			1	FILTER,MESH:	80009	378-0227-01
-16	378-0115-01			1	FILTER,LT,CRT:AMBER,4.176 X 3.418,PLASTIC	80009	378-0115-01
	378-0115-02			1	FILTER,LT,CRT:GRAY,4.176 X 3.418,PLASTIC	80009	378-0115-02
-17	015-0385-00			1	WG MIXER DIPLXR:	80009	015-0385-00
-18	015-1055-00			1	CABLE ASSY,RF:50 OHM COAX,3.382 L	80009	015-1055-00
-19	015-0388-00			1	ADAPTER,CONN:TNC MALE TO SMA MALE	05617	901168
-20	012-0074-00			1	CABLE ASSY,RF:75 OHM COAX,42.0 L	80009	012-0074-00
	070-5557-01			1	MANUAL,TECH:OPERATORS,494A	80009	070-5557-01
	070-5559-01			1	MANUAL,TECH:PROGRAMMERS,494A	80009	070-5559-01

OPTIONAL ACCESSORIES

012-0630-03	B010100	B010232		1	CABLE,INTCON:2.0M L	74868	AC30147-102
012-0991-00	B010233			1	CABLE,COMPOSITE:	00779	553577-3
006-3286-01				1	KIT,FIELD SVCE:A94,CUSTOMER SERVICE ONLY	80009	006-3286-01
015-0385-00				1	WG MIXER DIPLXR:	80009	015-0385-00
015-0388-00				1	ADAPTER,CONN:TNC MALE TO SMA MALE	05617	901168
015-0509-00				1	ADAPTER ASSY:N MALE TO N FEMALE 50 OHM,10KH Z TO 21GHZ,50V	93459	5201
015-1055-00				1	CABLE ASSY,RF:50 OHM COAX,3.382 L	80009	015-1055-00
016-0653-00				1	VISOR,CRT:FOLDING	80009	016-0653-00
016-0658-00				1	CASE,CARRYING:HARD SHELL	80009	016-0658-00
016-0659-00				1	CASE,CARRYING:SOFT SHELL OPTIC FIBER FAMILY	80009	016-0659-00
067-0971-00				1	FIXTURE,CAL:POWER SUPPLY EXTENDER	80009	067-0971-00
067-0972-00				1	FIXTURE,CAL:ACCESSORY INTERFACE EXTENDER	80009	067-0972-00
067-0973-00				1	FIXTURE,CAL:FRONT PANEL EXTENDER	80009	067-0973-00
067-1232-00				1	FIXTURE,CAL:IMPEDANCE MATCHING POWER SPLITTER	80009	067-1232-00
070-5558-00				1	MANUAL,TECH:OPERATORS HANDBOOK	80009	070-5558-00
070-5560-00				1	MANUAL,TECH:SERVICE,VOLUME 1	80009	070-5560-00
070-5561-00				1	MANUAL,TECH:SERVICE VOLUME 2	80009	070-5561-00
070-5567-00				1	MANUAL,TECH:PROGRAMMERS,REFERENCE GUIDE	80009	070-5567-00
175-2901-00				1	CA ASSY,SP,ELEC:2,22 AWG,20.0 L	80009	175-2901-00
175-2902-00				1	CABLE ASSY,RF:50 OHM COAX,12.0 L,CLEAR	80009	175-2902-00
367-0285-00				1	HANDLE,BOW:4.0 L,AL	80009	367-0285-00
672-0865-01				1	CIRCUIT BD ASSY:EXTENDER 670-5562-00 & 670-5563-00,670-8493-00 WIRED	80009	672-0865-01
211-0116-00				6	SCR,ASSEM WSHR:4-40 X 0.312,PNH,BRS,NP,POZ	77900	ORDER BY DESCR
426-1527-00				1	FRAME,CKT BOARD:EXTENDER,ALUMINUM	80009	426-1527-00
670-5562-00				1	CIRCUIT BD ASSY:LEFT EXTENDER	80009	670-5562-00
670-5563-00				1	CIRCUIT BD ASSY:RIGHT EXTENDER	80009	670-5563-00

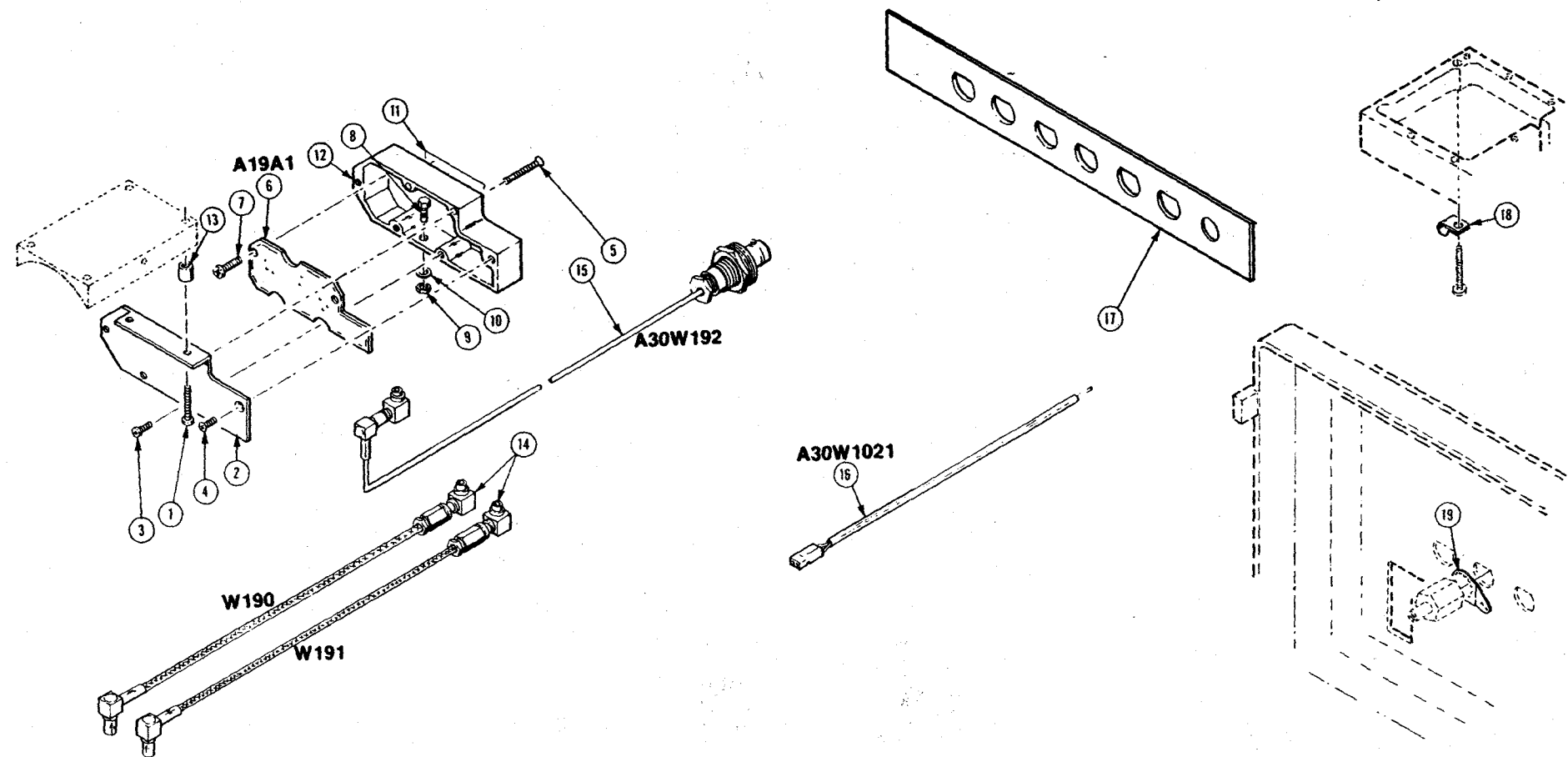

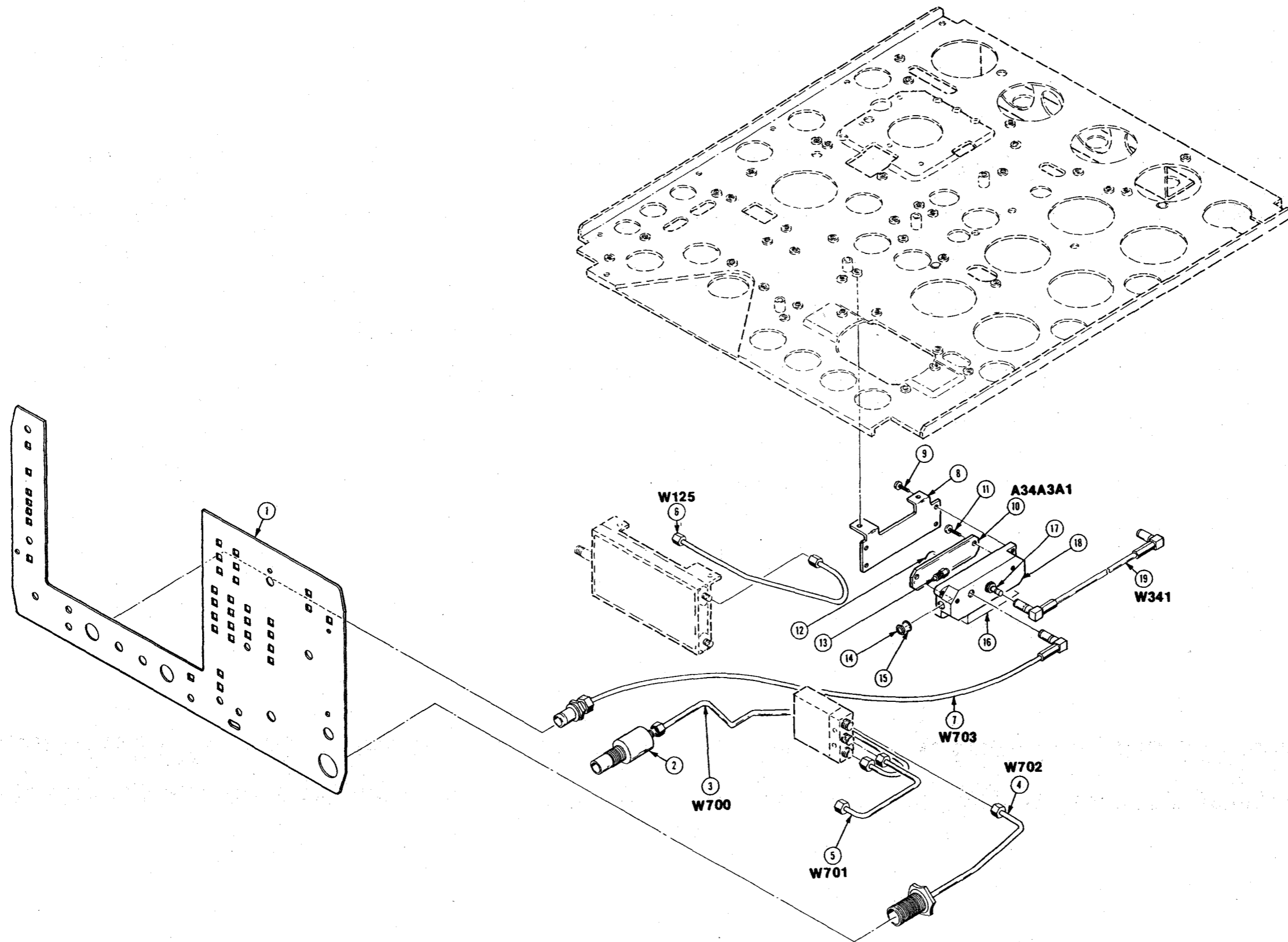

Replaceable Mechanical Parts
494A/494AP Service Vol.2

Fig. & Index No.	Tektronix Part No.	Serial/Assembly No.		Qty	12345 Name & Description	Mfr.	
		Effective	Discnt.			Code	Mfr. Part No.
8-	-----			AR	OPTION 21		
-1	-----			1	WG MIXER SET:HI PERFORMANCE,18-40GHZ (WM490-2)		
	-----			1	.WAVEGUIDE MIXER:18 TO 26.5GHZ (WM490K) (SEE 070-3731-XX MANUAL FOR PARTS BKDN)		
-2	-----			1	.WAVEGUIDE MIXER:26.5 TO 40GHZ (WM490A) (SEE 070-3731-XX MANUAL FOR PARTS BKDN)		
-3	012-0649-00			1	.CABLE ASSY,RF:50 OHM COAX,28.5 L	19505	80-9902-201
	016-0465-01			1	.CASE,ACCESSORY:HIGH PERFORMANCE	80009	016-0465-01
	070-3731-02			1	.MANUAL,TECH:INST,492/7L18	80009	070-3731-02
	-----				OPTION 22		
	-----			1	WG MIXER SET:HI PERFORMANCE,18-60GHZ (WM490-3)		
	-----			1	.WAVEGUIDE MIXER:18 TO 26.5GHZ (WM490K) (SEE 070-3731-XX MANUAL FOR PARTS BKDN)		
	-----			1	.WAVEGUIDE MIXER:26.5 TO 40GHZ (WM490A) (SEE 070-3731-XX MANUAL FOR PARTS BKDN)		
-4	-----			1	.WAVEGUIDE MIXER:40 TO 60GHZ (WM490U)		
	012-0649-00			1	.CABLE ASSY,RF:50 OHM COAX,28.5 L	19505	80-9902-201
	016-0465-01			1	.CASE,ACCESSORY:HIGH PERFORMANCE	80009	016-0465-01
	070-3731-02			1	.MANUAL,TECH:INST,492/7L18	80009	070-3731-02

Replaceable Mechanical Parts
494A/494AP Service Vol.2

Fig. & Index No.	Tektronix Part No.	Serial/Assembly No.		Qty	12345 Name & Description	Mfr.	
		Effective	Dscnt			Code	Mfr. Part No.
9-	-----			1	MHZ IF ASSY:(SEE A19 REPL) (ATTACHING PARTS)		
-1	211-0016-00			2	SCREW,MACHINE:4-40 X 0.625,PNH,STL (END ATTACHING PARTS)	TK0435	ORDER BY DESCR
-2	200-3041-00			1	.MHZ IF ASSY INCLUDES: .COVER,HOUSING:CKT BD,MACHINED SHEET AL (ATTACHING PARTS)	80009	200-3041-00
-3	211-0001-00			3	.SCREW,MACHINE:2-56 X 0.25,PNH,STL	93907	ORDER BY DESCR
-4	211-0030-00			1	.SCREW,MACHINE:2-56 X 0.25,FLH,82 DEG,STL	93907	ORDER BY DESCR
-5	213-0202-00			2	.SCREW,MACHINE:2-56 X 0.625,FLH 100 DEG (END ATTACHING PARTS)	TK0435	1199-302
-6	-----			1	.CKT BOARD ASSY:110MHZ IF OUT (SEE A19A1 REPL) (ATTACHING PARTS)		
-7	211-0168-00			2	.SCREW,MACHINE:4-40 X 0.25,PNH,BRS,NP (END ATTACHING PARTS)	12360	ORDER BY DESCR
-8	-----			1	.CAP,FXD,CER DI:(SEE A19C190 REPL) (ATTACHING PARTS)		
-9	210-0407-00			1	.NUT,PLATN,HEX:6-32 X 0.25,BRS CD PL	73743	3038-402
-10	210-0055-00			1	.WASHER,LOCK:#6 SPLIT,0.031 THK,STL (END ATTACHING PARTS)	81350	ORDER BY DESCR
-11	342-0390-00			1	.INSULATOR,SHLD:CKT BD,OFFSET OSC,POLYESTER	80009	342-0390-00
-12	380-0737-00			1	.HOUSING,CKT BD:MACHINED ALUMINUM CAVITY	80009	380-0737-00
-13	361-0917-00			2	SPACER,SLEEVE:0.25 L X 0.141 ID,ALUMINUM	80009	361-0917-00
-14	-----			2	CABLE ASSY,RF:50 OHM COAX,7.0L (SEE W190,W191 REPL)		
-15	-----			1	CABLE ASSY,RF:50 OHM COAX,16.0L,SEMI-RGD (SEE A30W192 REPL)		
-16	-----			1	CABLE ASSY,RF:500HM COAX,11.0 L,9-5 (SEE A30W1021 REPL)		
-17	333-3141-00	B010100	B010287	1	PANEL,REAR:	80009	333-3141-00
	334-7185-00	B010288		1	MARKER,IDENT:MARKED PROBE POWER	80009	334-7185-00
-18	343-0144-00			1	CLAMP,LOOP:0.125 ID,NYLON	TK1452	ORDER BY DESCR
-19	210-0255-00			1	TERMINAL,LUG:0.391 ID,LOCKING,BRS CD PL	12327	ORDER BY DESCR

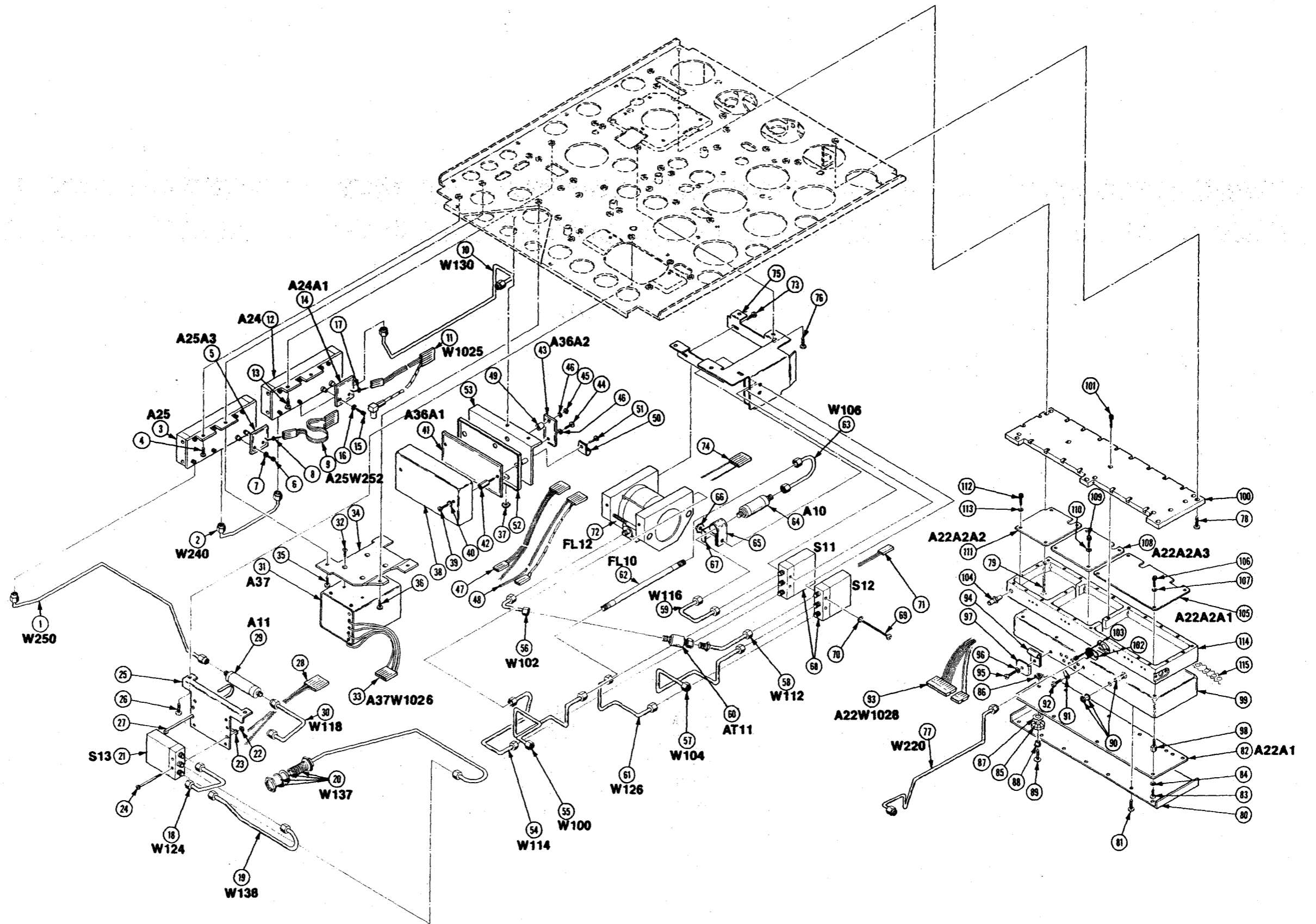

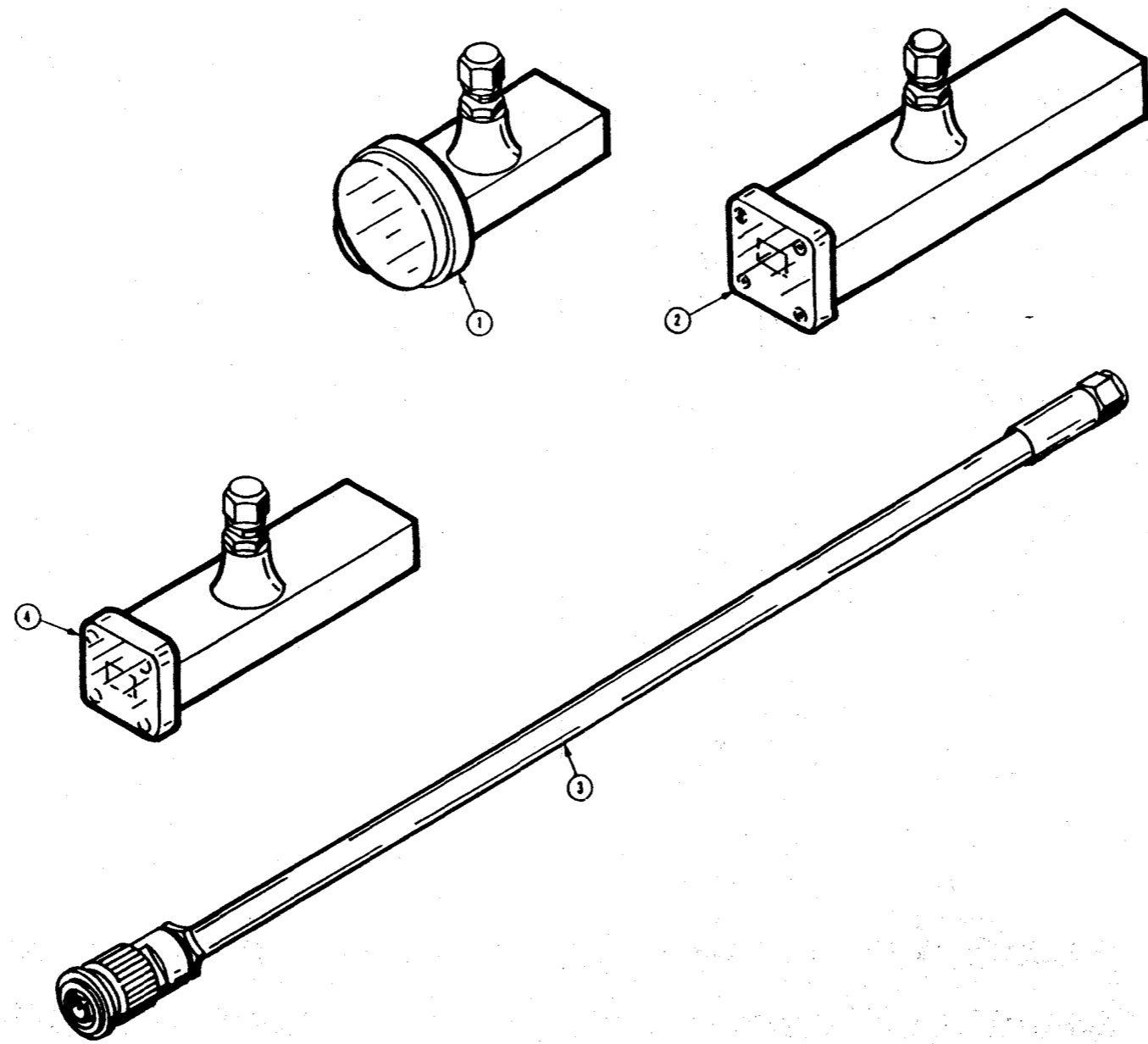

Replaceable Mechanical Parts
494A/494AP Service Vol.2

Fig. & Index No.	Tektronix Part No.	Serial/Assembly No.		Qty	12345 Name & Description	Mfr.	
		Effective	Dscnt			Code	Mfr. Part No.
6-1	-----			1	ATTENUATOR, VAR:(SEE AT10 REPL) (ATTACHING PARTS)		
-2	211-0008-01			2	SCREW,MACHINE:4-40 X 0.25,PNH,STL (END ATTACHING PARTS) ATTENUATOR INCLUDES:	26233	ORDER BY DESCR
-3	-----			1	.CABLE ASSY,RF:(SEE W101 REPL)		
-4	175-2371-00			1	.CA ASSY,SP,ELEC:6,26 AWG,8.5 L,RIBBON	80009	175-2371-00
-5	343-0013-00			1	CLAMP,LOOP:0.375 ID,PLASTIC (ATTACHING PARTS)	06915	ORDER BY DESCR
-6	211-0116-00			1	SCR,ASSEM WSHR:4-40 X 0.312,PNH,BRS,NP,POZ (END ATTACHING PARTS)	77900	ORDER BY DESCR
-7	-----			1	FIRST CONV ASSY:(SEE A12 REPL) (ATTACHING PARTS)		
-8	211-0008-01			2	SCREW,MACHINE:4-40 X 0.25,PNH,STL (END ATTACHING PARTS)	26233	ORDER BY DESCR
-9	-----			1	ATTENUATOR,FXD:(SEE AT12 REPL)		
-10	-----			1	CABLE ASSY,RF:(CABLE ASSY W100 REPL)		
-11	-----			2	FLTR CA ASY, RF:(SEE FL11 REPL)		
-12	-----			1	DIR FILTER ASSY:(SEE FL16 REPL) (ATTACHING PARTS)		
-13	211-0008-01			2	SCREW,MACHINE:4-40 X 0.25,PNH,STL (END ATTACHING PARTS)	26233	ORDER BY DESCR
-14	-----			1	CABLE ASSY RF:(SEE W162 REPL)		
-15	-----			1	FLTR CA ASSY,RF:(SEE FL15 REPL)		
-16	-----			1	DIPLEXER ASSY:(SEE A14 REPL) (ATTACHING PARTS)		
-17	211-0008-01			2	SCREW,MACHINE:4-40 X 0.25,PNH,STL (END ATTACHING PARTS)	26233	ORDER BY DESCR
	-----			1	OSC/MIXER ASSY:(SEE A34 REPL) (ATTACHING PARTS)		
-18	211-0008-01			2	SCREW,MACHINE:4-40 X 0.25,PNH,STL (END ATTACHING PARTS)	26233	ORDER BY DESCR
-19	-----			1	.CKT BOARD ASSY:100MHZ OSC REGULATOR (SEE A34A2 REPL)		
	346-0032-00			2	.STRAP,RETAINING:0.075 DIA X 4.0 L,MLD RBR	98159	2829-75-4
-21	-----			1	.CA ASSY,SP,ELEC:5,26 AWG,4.0L RIBBON ..(SEE A34A2W1017 REPL)		
-22	-----			1	.MICROCIRCUIT,LI:(SEE A34U1025 REPL) (ATTACHING PARTS)		
-23	210-0586-00	B010100	B010438	1	.NUT,PL,ASSEM WA:4-40 X 0.25,STL CD PL	78189	211-041800-00
	210-0406-00	B010439		1	.NUT,PLAIN,HEX:4-40 X 0.188,BRS CD PL	73743	12161-50
	210-0004-00	B010439		1	.WASHER,LOCK:#4 INTL,0.015 THK,STL	77900	1204-00-00-0541C
-24	210-1002-00			1	.WASHER,FLAT:0.125 ID X 0.25 OD X 0.022,BRS (END ATTACHING PARTS)	86928	5714-147-20N
-25	-----			1	.MICROCIRCUIT,LI:(SEE A34U1017 REPL) (ATTACHING PARTS)		
-26	210-0586-00	B010100	B010438	1	.NUT,PL,ASSEM WA:4-40 X 0.25,STL CD PL	78189	211-041800-00
	210-0406-00	B010439		1	.NUT,PLAIN,HEX:4-40 X 0.188,BRS CD PL	73743	12161-50
	210-0004-00	B010439		1	.WASHER,LOCK:#4 INTL,0.015 THK,STL	77900	1204-00-00-0541C
-27	210-1178-00			1	.WASHER,SHLDR:	80009	210-1178-00
-28	210-1002-00			1	.WASHER,FLAT:0.125 ID X 0.25 OD X 0.022,BRS	86928	5714-147-20N
-29	342-0355-00			1	.INSULATOR,PLATE:TRANSISTOR,SILICONE RUBBER (END ATTACHING PARTS)	55285	7403-09FR-51
-30	407-3033-01			1	.BRACKET,ANGLE:COPE & 3RD MIXER,ALUMINUM	80009	407-3033-01
-31	131-1972-00			2	.CONN,RCPT,ELEC:SNAP CATCH,MALE	80009	131-1972-00
-32	-----			6	.CONN,RCPT,ELEC:SNAP-ON,MALE (SEE A34P340,A34P341,A34P342,A34P344, A34P346,A34P347 REPL)		
-33	-----			1	.CKT BOARD ASSY:3RD CONVERTER (SEE A34A1 REPL) (ATTACHING PARTS)		
-34	129-1002-00			2	.SPACER,POST:0.485 L,0.188 HEX (END ATTACHING PARTS)	80009	129-1002-00
-35	131-0993-00			1	.CKT BOARD ASSY INCLUDES: ..CONN,BOX:SHUNT/SHORTING,;FEMALE,STR,1 X 2,0 ...1 CTR,0.385 H,30 GOLD,BLACK,JUMPER;	22526	65474-006
-36	131-0608-00			2	..TERMINAL,PIN:0.365 L X 0.025 BRZ GLD PL	80009	131-0608-00

Replaceable Mechanical Parts
494A/494AP Service Vol.2

Fig. & Index No.	Tektronix Part No.	Serial/Assembly No.		Qty	12345	Name & Description	Mfr.	
		Effective	Discont				Code	Mfr. Part No.
6-37	214-4085-00			3		.. TERM, TEST POINT: 0.070 ID, 0.220 H, 0.063 DIA .. PCB, 0.015 X 0.032 BRASS, W/ RED NYLON COLLAR	26364	104-01-02
-38	214-1919-00			2		.HEAT SK, HYB CKT: 1.17 L, CU BE, NI PL	80009	214-1919-00
-39	214-1920-00			1		.HEAT SK, HYB CKT: 1.5 L, CU BE, NI PL	80009	214-1920-00
-40	255-0678-00			AR		.PLASTIC EXTR: GROMMET, BLACK	18565	ORDER BY DESCR
-41	337-2574-03			1		.SHIELD, ELEC: 100MHZ & THIRD MIXER (ATTACHING PARTS)	80009	337-2574-03
-42	211-0012-00			2		.SCREW, MACHINE: 4-40 X 0.375, PNH, STL	93907	ORDER BY DESCR
-43	210-0004-00			2		.WASHER, LOCK: #4 INTL, 0.015 THK, STL (END ATTACHING PARTS)	77900	1204-00-00-0541C
-44	-----			1		CABLE ASSY, RF: (SEE W132 REPL)		
-45	-----			1		CABLE ASSY, RF: (SEE W166 REPL)		
-46	-----			1		POWER DIV ASSY: (SEE A13 REPL) (ATTACHING PARTS)		
-47	211-0008-01			2		SCREW, MACHINE: 4-40 X 0.25, PNH, STL (END ATTACHING PARTS)	26233	ORDER BY DESCR
-48	-----			1		WIRE, ELECTRICAL: 2 WIRE RIBBON (SEE W1038 REPL)		
-49	-----			1		WIRE SET, ELEC: (SEE W1037 REPL)		
-50	-----			1		OSCILLATOR, RF: (SEE A16 REPL) (ATTACHING PARTS)		
-51	210-0589-00			1		NUT, SLFLKG, HEX: 4-40 X 0.246, STL CD PL	TK0409	CF22NM40
-52	211-0014-00			1		SCREW, MACHINE: 4-40 X 0.5, PNH, STL (END ATTACHING PARTS)	93907	ORDER BY DESCR
-53	-----			1		OSCILLATOR, RF INCLUDES: .CKT BOARD ASSY: 1ST L.O. INTERFACE (SEE A16A1 REPL)		
-54	131-0608-00			11		.. TERMINAL, PIN: 0.365 L X 0.025 BRZ GLD PL	80009	131-0608-00
-55	361-0935-00			1		SPACER, OSC: ALUMINUM	80009	361-0935-00
-56	346-0161-01			1		STRAP, RETAINING: 1.54 L X 0.5 W, SST, W/BRKT (ATTACHING PARTS)	80009	346-0161-01
-57	211-0007-01			1		SCREW, MACHINE: 4-40 X 0.188, PNH, STL (END ATTACHING PARTS)	26233	ORDER BY DESCR
-58	346-0162-01			1		STRAP, RETAINING: 3.21 L X 0.5 W, SST, W/BRKT (ATTACHING PARTS)	80009	346-0162-01
-59	211-0007-01			1		SCREW, MACHINE: 4-40 X 0.188, PNH, STL (END ATTACHING PARTS)	26233	ORDER BY DESCR
-60	214-2769-00	B010100	B020692	1		HEAT SINK, OSC:	80009	214-2769-00
	214-2769-01	B020693		1		HEAT SINK, OSC: 49X, W/CUSHION (ATTACHING PARTS)	80009	214-2769-01
-61	211-0097-01			4		SCREW, MACHINE: 4-40 X 0.312, PNH, STL (END ATTACHING PARTS)	26233	ORDER BY DESCR
-62	-----			1		FILTER, BANDPASS: 110MHZ (SEE FL36 REPL) (ATTACHING PARTS)		
-63	211-0008-01			2		SCREW, MACHINE: 4-40 X 0.25, PNH, STL (END ATTACHING PARTS)	26233	ORDER BY DESCR
-64	-----			1		FILTER, LOWPASS: 110MHZ (SEE FL37 REPL) (ATTACHING PARTS)		
-65	210-0405-00			1		NUT, PLAIN, HEX: 2-56 X 0.188, BRS CD PL	73743	12157-50
-66	210-1307-00			1		WASHER, LOCK: 0.115 ID, SPLIT, 0.025 THK, SI BRZ (END ATTACHING PARTS)	86928	A384-25N
	-----			1		FILTER, AMPL: (SEE A32 REPL) (ATTACHING PARTS)		
-67	211-0008-01			2		SCREW, MACHINE: 4-40 X 0.25, PNH, STL (END ATTACHING PARTS)	26233	ORDER BY DESCR
-68	337-2575-01			1		AMP FILTER ASSY INCLUDES: .SHIELD, ELEC: CIRCUIT BOARD (ATTACHING PARTS)	80009	337-2575-01
-69	211-0012-01			2		.SCREW, MACHINE: 4-40 X 0.375, PNH, STL (END ATTACHING PARTS)	26233	ORDER BY DESCR
-70	255-0678-00			AR		.PLASTIC EXTR: GROMMET, BLACK	18565	ORDER BY DESCR
-71	-----			1		.CKT BOARD ASSY: 110 I.F. AMPLIFIER (SEE A32A1 REPL) (ATTACHING PARTS)		
-72	129-0236-00			2		.SPACER, POST: 0.375 L, 0.187 HEX (END ATTACHING PARTS)	06540	9726-A-0440
-73	-----			2		.CONNECTOR, RCPT, : 50 OHM MALE SNAP-ON (SEE A32P320, A32P321 REPL)		

Replaceable Mechanical Parts
494A/494AP Service Vol.2

Fig. & Index No.	Tektronix Part No.	Serial/Assembly No.		Qty	12345 Name & Description	Mfr.	
		Effective	Discnt			Code	Mfr. Part No.
6-74	214-1611-00			1	.HEAT SINK,XSTR:TO-5,CU BE BLK ENAMEL (ATTACHING PARTS)	05820	260-4T5E
-75	211-0007-01			1	.SCREW,MACHINE:4-40 X 0.188,PNH,STL	26233	ORDER BY DESCR
-76	210-1122-00			1	.WASHER,LOCK:0.12 ID,DISHED,0.025 THK,STL (END ATTACHING PARTS)	86928	ORDER BY DESCR
-77	407-2148-00			1	.BRACKET,ANGLE:IF AMPLIFIER,ALUMINUM	80009	407-2148-00
-78	175-2369-00			1	.CA ASSY,SP,ELEC:2,26 AWG,5.0 L,RIBBON	80009	175-2369-00
-79	-----			4	.TERM,COAXIAL:(SEE P133,P144,P145, .P164 REPL)		
-80	-----			1	SEC CONV ASSY:(SEE A18 REPL) (ATTACHING PARTS)		
-81	211-0008-01			4	SCREW,MACHINE:4-40 X 0.25,PNH,STL (END ATTACHING PARTS) SEC CONV ASSY INCLUDES:	26233	ORDER BY DESCR
-82	-----			1	.CABLE ASSY,RF:(SEE A18W140 REPL)		
-83	-----			1	.CABLE ASSY,RF:(SEE A18W222 REPL)		
-84	175-2370-00			1	.CA ASSY,SP,ELEC:3,26 AWG,5.5 L	80009	175-2370-00
-85	-----			1	CABLE ASSY,RF:(SEE W236 REPL)		
	-----			1	SEC CON ASSY:829MHZ(SEE A23 REPL) (ATTACHING PARTS)		
-86	211-0008-01			3	SCREW,MACHINE:4-40 X 0.25,PNH,STL	26233	ORDER BY DESCR
-87	211-0128-00			3	SCREW,MACHINE:2-56 X 1.375,PNH,STL (END ATTACHING PARTS) SEC CON ASSY INCLUDES:	TK0858	ORDER BY DESCR
-88	200-2333-01			1	.COVER,CONVERTER:829MHZ,BOTTOM,AL (ATTACHING PARTS)	80009	200-2333-01
-89	211-0162-01			33	.SCREW,CAP:2-56 X 0.188,SCH,SST,HEX REC,W/NY .LON PATCH (END ATTACHING PARTS)	26233	ORDER BY DESCR
-90	-----			1	.CKT BOARD ASSY:110MHZ IF SELECT (SEE A23A6 REPL) (ATTACHING PARTS)		
-91	211-0162-01			5	.SCREW,CAP:2-56 X 0.188,SCH,SST,HEX REC,W/NY .LON PATCH	26233	ORDER BY DESCR
-92	210-1008-00			5	.WASHER,FLAT:0.09 ID X 0.188 OD X 0.02,BRS (END ATTACHING PARTS)	12327	ORDER BY DESCR
-93	-----			1	.CKT BOARD ASSY:829MHZ SECOND CONVERTER (SEE A23A7 REPL) (ATTACHING PARTS)		
-94	211-0162-01			7	.SCREW,CAP:2-56 X 0.188,SCH,SST,HEX REC,W/NY .LON PATCH	26233	ORDER BY DESCR
-95	210-1008-00			7	.WASHER,FLAT:0.09 ID X 0.188 OD X 0.02,BRS (END ATTACHING PARTS) CKT BOARD ASSY INCLUDES:	12327	ORDER BY DESCR
-96	175-2462-00			2	.CABLE ASSY,RF:50 OHM COAX,2.3 L	80009	175-2462-00
-97	175-2463-00			2	.CABLE ASSY,RF:50 OHM COAX,1.97 L	80009	175-2463-00
-98	-----			1	.CKT BOARD ASSY:829MHZ AMPLIFIER (SEE A23A5 REPL) (ATTACHING PARTS)		
-99	211-0162-01			4	.SCREW,CAP:2-56 X 0.188,SCH,SST,HEX REC,W/NY .LON PATCH	26233	ORDER BY DESCR
-100	210-1008-00			4	.WASHER,FLAT:0.09 ID X 0.188 OD X 0.02,BRS (END ATTACHING PARTS) CKT BOARD ASSY INCLUDES:	12327	ORDER BY DESCR
-101	175-9059-00			1	.CA ASSY,SP,ELEC:3,26 AWG,6.5 L,RIBBON	TK1375	175-9059-00
-102	131-1003-00			1	.CONN,RCPT,ELEC:CKT BD MT,3 PRONG	80009	131-1003-00
-103	136-0252-00			1	.SOCKET,PIN TERM:	80009	136-0252-00
-104	-----			1	.CKT BOARD ASSY:829MHZ DIPLEXER (A23A4 REPL) (ATTACHING PARTS)		
-105	211-0162-01			5	.SCREW,CAP:2-56 X 0.188,SCH,SST,HEX REC,W/NY .LON PATCH	26233	ORDER BY DESCR
-106	210-1008-00			5	.WASHER,FLAT:0.09 ID X 0.188 OD X 0.02,BRS (END ATTACHING PARTS)	12327	ORDER BY DESCR
-107	343-0144-00			1	.CLAMP,LOOP:0.125 ID,NYLON (ATTACHING PARTS)	TK1452	ORDER BY DESCR
-108	211-0200-01			1	.SCREW,CAP:4-40 X 0.25,SCH,SST,HEX REC	26233	ORDER BY DESCR
-109	210-0054-00			1	.WASHER,LOCK:#4 SPLIT,0.025 THK STL	78189	ORDER BY DESCR

Replaceable Mechanical Parts
494A/494AP Service Vol.2

Fig. & Index No.	Tektronix Part No.	Serial/Assembly No. Effective	Discont.	Qty	12345 Name & Description	Mfr. Code	Mfr. Part No.
6-					.(END ATTACHING PARTS)		
-110	175-2900-00			1	.CA ASSY,SP,ELEC:6,26 AWG,7.0 L,RIBBON	TK1375	175-2900-00
-111	210-0261-00			1	.TERMINAL,LUG:0.14 ID,PLAIN,BRASS,CD PL BRIG .HT . (ATTACHING PARTS)	91260	ORDER BY DESCR
-112	211-0200-01			1	.SCREW,CAP:4-40 X 0.25,SCH,SST,HEX REC	26233	ORDER BY DESCR
-113	210-0054-00			1	.WASHER,LOCK:#4 SPLIT,0.025 THK STL . (END ATTACHING PARTS)	78189	ORDER BY DESCR
-114	200-2334-01			1	.COVER,CONVERTER:829MHZ,TOP,AL . (ATTACHING PARTS)	80009	200-2334-01
-115	211-0162-01			39	.SCREW,CAP:2-56 X 0.188,SCH,SST,HEX REC,W/NY .LON PATCH . (END ATTACHING PARTS)	26233	ORDER BY DESCR
-116	-----			1	.CKT BOARD ASSY:829MHZ HARMONIC MIXER . (SEE A23A3 REPL) . (ATTACHING PARTS)		
-117	211-0162-01			5	.SCREW,CAP:2-56 X 0.188,SCH,SST,HEX REC,W/NY .LON PATCH	26233	ORDER BY DESCR
-118	210-1008-00			5	.WASHER,FLAT:0.09 ID X 0.188 OD X 0.02,BRS . (END ATTACHING PARTS) .CKT BOARD ASSY INCLUDES:	12327	ORDER BY DESCR
-119	136-0263-06			2	.SOCKET,PIN TERM:U/W 0.025 SQ PIN	80009	136-0263-06
-120	131-1612-03			5	.TERM,FEEDTHRU:U-SHP,0.3 L X 0.35 L X 0.25	80009	131-1612-03
-121	-----			1	.CKT BOARD ASSY:719MHZ SECOND LO . (SEE A23A1 REPL) . (ATTACHING PARTS)		
-122	211-0162-01			4	.SCREW,CAP:2-56 X 0.188,SCH,SST,HEX REC,W/NY .LON PATCH	26233	ORDER BY DESCR
-123	210-1008-00			4	.WASHER,FLAT:0.09 ID X 0.188 OD X 0.02,BRS . (END ATTACHING PARTS) .CKT BOARD ASSY INCLUDES:	12327	ORDER BY DESCR
-124	131-1003-00			1	.CONN,RCPT,ELEC:CKT BD MT,3 PRONG	80009	131-1003-00
-125	136-0252-07			1	.SOCKET,PIN CONN:SINGLE,PCB,T/G,0.030 H,0.05 .4 PCB,0.012-0.22 PIN SIZE,W/O DIMPLE,25000/ .REEL	80009	136-0252-07
-126	214-4085-00			1	.TERM,TEST POINT:0.070 ID,0.220 H,0.063 DIA .PCB,0.015 X 0.032 BRASS,W/ RED NYLON COLLAR	26364	104-01-02
-127	136-0263-06			4	.SOCKET,PIN TERM:U/W 0.025 SQ PIN	80009	136-0263-06
-128	-----			1	.CKT BOARD ASSY:25MHZ PHASE LOCK . (SEE A23A2 REPL) . (ATTACHING PARTS)		
-129	211-0200-01			2	.SCREW,CAP:4-40 X 0.25,SCH,SST,HEX REC	26233	ORDER BY DESCR
-130	210-1002-00			2	.WASHER,FLAT:0.125 ID X 0.25 OD X 0.022,BRS . (END ATTACHING PARTS) .CKT BOARD ASSY INCLUDES:	86928	5714-147-20N
-131	136-0263-04			4	.SOCKET,PIN TERM:U/W 0.025 SQ PIN	80009	136-0263-04
-132	214-4085-00			2	.TERM,TEST POINT:0.070 ID,0.220 H,0.063 DIA .PCB,0.015 X 0.032 BRASS,W/ RED NYLON COLLAR	26364	104-01-02
-133	-----			1	.MICROCIRCUIT:(SEE A23U1013 REPL) . (ATTACHING PARTS)		
-134	211-0162-01			1	.SCREW,CAP:2-56 X 0.188,SCH,SST,HEX REC,W/NY .LON PATCH	26233	ORDER BY DESCR
-135	210-1002-00			1	.WASHER,FLAT:0.125 ID X 0.25 OD X 0.022,BRS . (END ATTACHING PARTS)	86928	5714-147-20N
-136	-----			1	.MICROCIRCUIT:(SEE A23U2026 REPL) . (ATTACHING PARTS)		
-137	211-0162-01			1	.SCREW,CAP:2-56 X 0.188,SCH,SST,HEX REC,W/NY .LON PATCH	26233	ORDER BY DESCR
-138	210-1002-00			1	.WASHER,FLAT:0.125 ID X 0.25 OD X 0.022,BRS	86928	5714-147-20N
-139	210-1178-00			1	.WASHER,SHLDR: . (END ATTACHING PARTS)	80009	210-1178-00
-140	-----			1	.MICROCIRCUIT:(SEE A23U3024 REPL) . (ATTACHING PARTS)		
-141	211-0162-01			1	.SCREW,CAP:2-56 X 0.188,SCH,SST,HEX REC,W/NY .LON PATCH	26233	ORDER BY DESCR
-142	210-1002-00			1	.WASHER,FLAT:0.125 ID X 0.25 OD X 0.022,BRS	86928	5714-147-20N
-143	210-1178-00			1	.WASHER,SHLDR: . (END ATTACHING PARTS)	80009	210-1178-00

Replaceable Mechanical Parts
494A/494AP Service Vol.2

Fig. & Index No.	Tektronix Part No.	Serial/Assembly No.		Qty	12345 Name & Description	Mfr.	
		Effective	Discont			Code	Mfr. Part No.
6-144	131-2017-00			3	.CONN,RF JACK: .(ATTACHING PARTS)	80009	131-2017-00
-145	211-0162-01			6	.SCREW,CAP:2-56 X 0.188,SCH,SST,HEX REC,W/NY .LON PATCH .(END ATTACHING PARTS)	26233	ORDER BY DESCR
-146	131-1170-00			3	.CONN,RF JACK:	80009	131-1170-00
-147	380-0567-02			1	.HOUSING,CONV:829MHZ,ALUMINUM	80009	380-0567-02
-148	348-0089-00			7	BUMPER,PLASTIC:0.312 DIA X 0.855 L,BLACK	80009	348-0089-00
-149	441-1697-00			1	CHASSIS,SCOPE: (ATTACHING PARTS)	80009	441-1697-00
-150	211-0105-00			3	SCREW,MACHINE:4-40 X 0.188,FLH,100 DEG	TK0435	ORDER BY DESCR
-151	211-0513-00			4	SCREW,MACHINE:6-32 X 0.625,PNH,STL (END ATTACHING PARTS)	93907	B80-00032-003

Replaceable Mechanical Parts
494A/494AP Service Vol.2

Fig. & Index No.	Tektronix Part No.	Serial/Assembly No. Effective	Discnt	Qty	12345 Name & Description	Mfr. Code	Mfr. Part No.
7-1	-----			1	CABLE ASSY,RF:50 OHM COAX,HARMONIC MIXER (SEE W250 REPL)		
-2	-----			1	CABLE ASSY,RF:50 OHM COAX,HARMONIC MIXER (SEE W240 REPL)		
-3	-----			1	HARMONIC MIXER:(SEE A25 REPL) (ATTACHING PARTS)		
-4	211-0008-01			2	SCREW,MACHINE:4-40 X 0.25,PNH,STL (END ATTACHING PARTS) HARMONIC MIXER INCLUDES	26233	ORDER BY DESCR
-5	-----			1	.CKT BOARD ASSY:HARMONIC MIXER INPUT (SEE A25A3 REPL) (ATTACHING PARTS)		
-6	211-0162-00			2	SCREW,MACHINE:2-56 X 0.188,SCH,SST	TK0428	ORDER BY DESCR
-7	210-1301-00			2	.WASHER,GROUND:0.285 OD X 0.17 ID X 0.0063 T .HK PH BRZ (END ATTACHING PARTS) .CKT BOARD ASSY INCLUDES:	86928	A367243
-8	131-1426-00			1	.CONN,HDR:PCB,;MALE,RTANG,1 X 36,0.1 CTR,0.2 .3 MLG X 0.195 TAIL,GOLD,STACKABLE;,,	22526	65524-136
-9	-----			1	.CA ASSY,SP,ELEC:5,26 AWG,3.0 L,RIBBON (SEE A25W252 REPL)		
-10	-----			1	CABLE ASSY,RF:50 OHM COAX,10.29 INCH LONG (SEE W130 REPL)		
-11	-----			1	CA ASSY,SP,ELEC:2.26 AWG,5.0 INCH LONG (SEE W1025 REPL)		
-12	-----			1	HYBRID CKT ASSY:(SEE A24 REPL) (ATTACHING PARTS)		
-13	211-0008-01			2	SCREW,MACHINE:4-40 X 0.25,PNH,STL (END ATTACHING PARTS)	26233	ORDER BY DESCR
-14	-----			1	.CKT BOARD ASSY:PHASE GATE INPUT (SEE A24A1 REPL) (ATTACHING PARTS)		
-15	211-0278-00			2	SCREW,CAP:2-56 X 0.5 L,SKT HD,SST	TK0456	ORDER BY DESCR
-16	210-1301-00			2	.WASHER,GROUND:0.285 OD X 0.17 ID X 0.0063 T .HK PH BRZ (END ATTACHING PARTS) .CKT BOARD ASSY INCLUDES:	86928	A367243
-17	131-1425-00			1	.CONN,HDR:PCB,;MALE,RTANG,1 X 36,0.1 CTR,0.2 .30 MLG X 0.090 TAIL,30 GOLD,STACKABLE;,,	22526	65521-136
-18	-----			1	CABLE ASSY,RF:50 OHM COAX,6.1 (SEE W124 REPL)		
-19	-----			1	CABLE ASSY,RF:50 OHM COAX,6.1 (SEE W138 REPL)		
-20	-----			1	CABLE ASSY,RF:50 OHM COAX W/O JKT,SEMI-RI (SEE W137 REPL)		
-21	-----			1	SW,RF XMSN LINE:(SEE S13 REPL) (ATTACHING PARTS)		
-22	210-0405-00			2	NUT,PLAIN,HEX:2-56 X 0.188,BRS CD PL	73743	12157-50
-23	210-0259-00			1	TERMINAL,LUG:0.099 ID,LOCKING,BRS CD PL	80009	210-0259-00
-24	211-0128-00			2	SCREW,MACHINE:2-56 X 1.375,PNH,STL (END ATTACHING PARTS)	TK0858	ORDER BY DESCR
-25	407-2390-00			1	BRACKET,ELEC SW:ALUMINUM (ATTACHING PARTS)	80009	407-2390-00
-26	211-0008-01			2	SCREW,MACHINE:4-40 X 0.25,PNH,STL (END ATTACHING PARTS)	26233	ORDER BY DESCR
-27	343-0549-00			1	STRAP,TIEDOWN,E:0.098 W X 4.0 L,ZYTEL	06383	PLT1M
-28	175-3159-00			1	CA ASSY,SP,ELEC:4,26 AWG,6.0 L,RIBBON	TK1375	175-3159-00
-29	-----			1	BIAS RETURN:(SEE A11 REPL)		
-30	-----			1	CABLE ASSY,RF:50 OHM COAX,3.63 INCH LONG (SEE W118 REPL)		
-31	-----			1	OSCILLATOR,RF:(SEE A37 REPL) (ATTACHING PARTS)		
-32	211-0097-01			4	SCREW,MACHINE:4-40 X 0.312,PNH,STL (END ATTACHING PARTS) OSCILLATOR ASSY INCLUDES:	26233	ORDER BY DESCR
-33	-----			1	.CA ASSY,SP,ELEC:(SEE A37W1026 REPL)		
-34	407-3031-00	8010100	8020593	1	BRACKET,SCOPE:ALUMINUM (ATTACHING PARTS)	80009	407-3031-00

Replaceable Mechanical Parts
494A/494AP Service Vol.2

Fig. & Index No.	Tektronix Part No.	Serial/Assembly No.		Qty	12345 Name & Description	Mfr.	
		Effective	Dscont			Code	Mfr. Part No.
7-35	211-0008-01			2	SCREW,MACHINE:4-40 X 0.25,PNH,STL	26233	ORDER BY DESCR
-36	211-0105-00			2	SCREW,MACHINE:4-40 X 0.188,FLH,100 DEG (END ATTACHING PARTS)	TK0435	ORDER BY DESCR
	-----			1	PH LOCK 3RD LO:(SEE A36 REPL) (ATTACHING PARTS)		
-37	210-0589-00			2	NUT,SLFLKG,HEX:4-40 X 0.246,STL CD PL (END ATTACHING PARTS)	TK0409	CF22NM40
-38	337-2980-00			1	PH LOCK LO ASSY INCLUDES: .SHIELD,ELEC:REFERENCE LOCK (ATTACHING PARTS)	80009	337-2980-00
-39	211-0097-00			2	.SCREW,MACHINE:4-40 X 0.312,PNH,STL	93907	ORDER BY DESCR
-40	210-0004-00			2	WASHER,LOCK:#4 INTL,0.015 THK,STL (END ATTACHING PARTS)	77900	1204-00-00-0541C
-41	-----			1	.CKT BOARD ASSY:REF LOCK(SEE A36A1 REPL) (ATTACHING PARTS)		
-42	129-1002-00			2	.SPACER,POST:0.485 L,0.188 HEX (END ATTACHING PARTS)	80009	129-1002-00
-43	-----			1	.CKT BOARD ASSY:REF LOCK REGULATOR (SEE A36A2 REPL) (ATTACHING PARTS)		
-44	211-0005-00			1	.SCREW,MACHINE:4-40 X 0.125,PNH,STL	TK0435	ORDER BY DESCR
-45	210-0406-00			1	.NUT,PLAIN,HEX:4-40 X 0.188,BRS CD PL	73743	12161-50
-46	210-1307-00			2	WASHER,LOCK:0.115 ID,SPLIT,0.025 THK,SI BRZ (END ATTACHING PARTS)	86928	A384-25N
-47	175-8741-00			1	.CA ASSY,SP,ELEC:5,26 AWG,7.0 L,RIBBON	TK1375	175-8741-00
-48	198-5213-00			1	.WIRE SET,ELEC:	TK1375	198-5213-00
-49	361-0981-00			1	.SPACER,SLEEVE:0.180 L X 0.126 ID,BRASS	80009	361-0981-00
-50	343-0144-00			1	.CLAMP,LOOP:0.125 ID,NYLON (ATTACHING PARTS)	TK1452	ORDER BY DESCR
-51	211-0005-00			1	.SCREW,MACHINE:4-40 X 0.125,PNH,STI (END ATTACHING PARTS)	TK0435	ORDER BY DESCR
-52	432-0142-00			1	.BASE,REF LOCK:	80009	432-0142-00
-53	407-3032-00			1	.BRACKET,ANGLE:REF LOCK,ALUMINUM	80009	407-3032-00
-54	-----			1	CABLE ASSY,RF:50 OHM COAX,6.34 INCH LONG (SEE W114 REPL)		
-55	-----			AR	CABLE ASSY,RF:(SEE W100 REPL)		
-56	-----			1	CABLE ASSY,RF:(SEE W102 REPL)		
-57	-----			1	CABLE ASSY,RF:(SEE W104 REPL)		
-58	-----			1	CABLE ASSY,RF:(SEE W112 REPL)		
-59	-----			1	CABLE ASSY,RF:(SEE W116 REPL)		
-60	-----			1	ATTENUATOR:(SEE AT11 REPL)		
-61	-----			1	CABLE ASSY,RF:50 OHM COAX,2.59 INCH LONG (SEE W126 REPL)		
-62	-----			1	FILTER,LOW PASS:(SEE FL10 REPL)		
-63	-----			1	CABLE ASSY,RF:(SEE W106 REPL)		
-64	-----			1	LIMITER ASSY:(SEE A10 REPL)		
-65	343-0006-00			1	CLAMP,LOOP:0.5 ID,PLASTIC (ATTACHING PARTS)	06915	ORDER BY DESCR
-66	210-0458-00			1	NUT,PL,ASSEM WA:8-32 X 0.344,STL CD PL	78189	511-081800-00
-67	210-0863-00			1	WSHR,LOOP CLAMP:0.091 ID U/W 0.5 W CLP,STL CD PL (END ATTACHING PARTS)	95987	C191
-68	-----			2	(SW,RF XMSN LINE:(SEE S11,S12 REPL) (ATTACHING PARTS)		
-69	211-0128-00			2	SCREW,MACHINE:2-56 X 1.375,PNH,STL	TK0858	ORDER BY DESCR
-70	210-0001-00			2	WASHER,LOCK:#2 INTL,0.013 THK,STL (END ATTACHING PARTS)	77900	1202-00-00-0541C
-71	198-3048-00			1	WIRE SET,ELEC:	TK1375	198-3048-00
	352-0169-00			1	.HLDR,TERM CONN:2 WIRE,BLACK	80009	352-0169-00
-72	-----			1	YIG TUNED FLTR:(SEE FL12 REPL) (ATTACHING PARTS)		
-73	211-0008-00			4	SCREW,MACHINE:4-40 X 0.25,PNH,STL (END ATTACHING PARTS)	93907	ORDER BY DESCR
-74	175-2373-00			1	YIG TUNED FLTR INCLUDES: .CA ASSY,SP,ELEC:2,26 AWG,3.0 L,RIBBON	TK1375	175-2373-00
-75	407-3222-00			1	BRACKET,SWITCH:YIG FILTER,ALUMINUM (ATTACHING PARTS)	80009	407-3222-00

Replaceable Mechanical Parts
494A/494AP Service Vol.2

Fig. & Index No.	Tektronix Part No.	Serial/Assembly No. Effective	Dscont	Qty	12345 Name & Description	Mfr. Code	Mfr. Part No.
7-76	211-0008-00			5	SCREW,MACHINE:4-40 X 0.25,PNH,STL (END ATTACHING PARTS)	93907	ORDER BY DESCR
-77	-----			1	CABLE ASSY,RF:50 OHM COAX,8.9 L,SEMIRIGTD (SEE W220 REPL)		
	-----			1	PH LOCK 2ND LO:(SEF A22 REPL) (ATTACHING PARTS)		
-78	211-0012-01			4	SCREW,MACHINE:4-40 X 0.375,PNH,STL	26233	ORDER BY DESCR
-79	211-0628-00			1	SCREW,MACHINE:6-32 X 1.125,PNH,SST (END ATTACHING PARTS)	83385	ORDER BY DESCR
-80	200-2611-00			1	PHASE LOCK 2ND LO ASSY INCLUDES: .COVER,2ND LO:PHASELOCKED CONTROL,PERMALOY (ATTACHING PARTS)	80009	200-2611-00
-81	211-0005-00			14	SCREW,MACHINE:4-40 X 0.125,PNH,STL (END ATTACHING PARTS)	TK0435	ORDER BY DESCR
-82	-----			1	CKT BOARD ASSY:16-20MHZ PHASELOCK (SEE A22A1 REPL) (ATTACHING PARTS)		
-83	211-0196-00			8	SCREW,MACHINE:4-40 X 0.188,SCH,STL	TK0428	ORDER BY DESCR
-84	210-1002-00			8	WASHER,FLAT:0.125 ID X 0.25 OD X 0.022,BRS (END ATTACHING PARTS)	86928	5714-147-20N
-85	-----			1	CKT BOARD ASSY INCLUDES: ..TRANSFORMER,RF:(SEE A22A1T2092 REPL) ..(ATTACHING PARTS)		
-86	210-0586-00			1	..NUT,PL,ASSEM WA:4-40 X 0.25,STL CD PL	78189	211-041800-00
-87	210-0894-00			1	..WASHER,FLAT:0.19 ID X 0.438 OD X 0.031	09422	ORDER BY DESCR
-88	210-1171-00			1	..WASHER,SHLDR:0.12 ID X 0.143 OD X 0.07 D	00261	A7148516P2
-89	211-0036-00			1	..SCREW,MACHINE:4-40 X 0.5,BDGH,NYL ..(END ATTACHING PARTS)	26365	ORDER BY DESCR
-90	131-0372-00			1	..CONN,RF PLUG:	80009	131-0372-00
-91	210-0261-00			1	..TERMINAL,LUG:0.14 ID,PLAIN,BRASS,CD PL BRIG .HT (ATTACHING PARTS)	91260	ORDER BY DESCR
-92	211-0005-00			1	SCREW,MACHINE:4-40 X 0.125,PNH,STL (END ATTACHING PARTS)	TK0435	ORDER BY DESCR
-93	-----			1	..CA ASSY,SP,ELEC:8.26 AWG,7.5 L,RIBBON (SEE A22W1048 REPL)		
-94	343-0002-00			1	..CLAMP,LOOP:0.187 ID,PLASTIC (ATTACHING PARTS)	06915	E3 CLEAR ROUND
-95	211-0097-01			1	SCREW,MACHINE:4-40 X 0.312,PNH,STL	26233	ORDER BY DESCR
-96	210-1002-00			1	WASHER,FLAT:0.125 ID X 0.25 OD X 0.022,BRS	86928	5714-147-20N
-97	210-0863-00			1	..WSHR,LOOP CLAMP:0.091 ID U/W 0.5 W CLP,STL .CD PL (END ATTACHING PARTS)	95987	C191
-98	129-0889-00			8	..SPACER,POST:0.4 L,0.217 HEX	80009	129-0889-00
-99	380-0664-00			1	..HOUSING,2ND LO:PHASELOCKED CONTROL	80009	380-0664-00
	-----			1	..PH LOCK LO CONT:(SEE A22A2 REPL)		
-100	200-2610-00			1	..COVER,2ND LO:PHASELOCKED,AL ..(ATTACHING PARTS)	TK1566	ORDER BY DESCR
-101	211-0256-00			26	..SCREW,CAP:2-56 X 0.25,HEX SCH,SST ..(END ATTACHING PARTS)	83385	ORDER BY DESCR
-102	-----			2	..CONN,RCPT,ELEC:SMA FEMALE,FLANGE MOUNT ..(SEE A22A2P220,A22A2P222 REPL) ..(ATTACHING PARTS)		
-103	211-0261-01			4	..SCREW,CAP:2-56 X 0.125,HEX,SCH,SST ..(END ATTACHING PARTS)	26233	ORDER BY DESCR
-104	-----			1	..CONN,RCPT,ELEC:SNAP-ON,MALE ..(SEE A22A2P221 REPL)		
-105	-----			1	..CKT BOARD ASSY:2182MHZ MICRO STRIP OSC ..(SEE A22A2A1 REPL) ..(ATTACHING PARTS)		
-106	211-0162-01	B010100	B010172	6	..SCREW,CAP:2-56 X 0.188,SCH,SST,HEX REC,W/NY ..LON PATCH	26233	ORDER BY DESCR
	211-0162-00	B010173		6	..SCREW,MACHINE:2-56 X 0.188,SCH,SST	TK0428	ORDER BY DESCR
-107	210-1008-00	B010100	B010172	6	..WASHER,FLAT:0.09 ID X 0.188 OD X 0.02,BRS	12327	ORDER BY DESCR
	210-0001-00	B010173		6	..WASHER,LOCK:#2 INTL,0.013 THK,STL ..(END ATTACHING PARTS)	77900	1202-00-00-0541C
-108	-----			1	..CKT BOARD ASSY:2200MHZ REFERENCE MIXER ..(SEE A22A2A3 REPL)		

Replaceable Mechanical Parts
494A/494AP Service Vol.2

Fig. & Index No.	Tektronix Part No.	Serial/Assembly No. Effective	Dscont	Qty	12345 Name & Description	Mfr. Code	Mfr. Part No.
7-					..(ATTACHING PARTS)		
-109	211-0162-01	B010100	B010172	4	..SCREW,CAP:2-56 X 0.188,SCH,SST,HEX REC,W/NY	26233	ORDER BY DESCR
					..LON PATCH		
	211-0162-00	B010173		4	..SCREW,MACHINE:2-56 X 0.188,SCH,SST	TK0428	ORDER BY DESCR
-110	210-1008-00	B010100	B010172	4	..WASHER,FLAT:0.09 ID X 0.188 OD X 0.02,BRS	12327	ORDER BY DESCR
	210-0001-00	B010173		4	..WASHER,LOCK:#2 INTL,0.013 THK,STL	77900	1202-00-00-0541C
					..(END ATTACHING PARTS)		
-111	-----			1	..CKT BOARD ASSY:2200MHZ REFERENCE		
					..(SEE A22A2A2 REPL)		
					..(ATTACHING PARTS)		
-112	211-0162-01	B010100	B010172	4	..SCREW,CAP:2-56 X 0.188,SCH,SST,HEX REC,W/NY	26233	ORDER BY DESCR
					..LON PATCH		
	211-0162-00	B010173		4	..SCREW,MACHINE:2-56 X 0.188,SCH,SST	TK0428	ORDER BY DESCR
-113	210-1008-00	B010100	B010172	4	..WASHER,FLAT:0.09 ID X 0.188 OD X 0.02,BRS	12327	ORDER BY DESCR
	210-0001-00	B010173		4	..WASHER,LOCK:#2 INTL,0.013 THK,STL	77900	1202-00-00-0541C
					..(END ATTACHING PARTS)		
-114	380-0665-00	-		1	..HOUSING,2ND LO:PHASELOCKED,AL	TK1566	ORDER BY DESCR
-115	348-0750-01			2	.GASKET:PHASE LOCKED 2ND LO	80009	348-0750-01

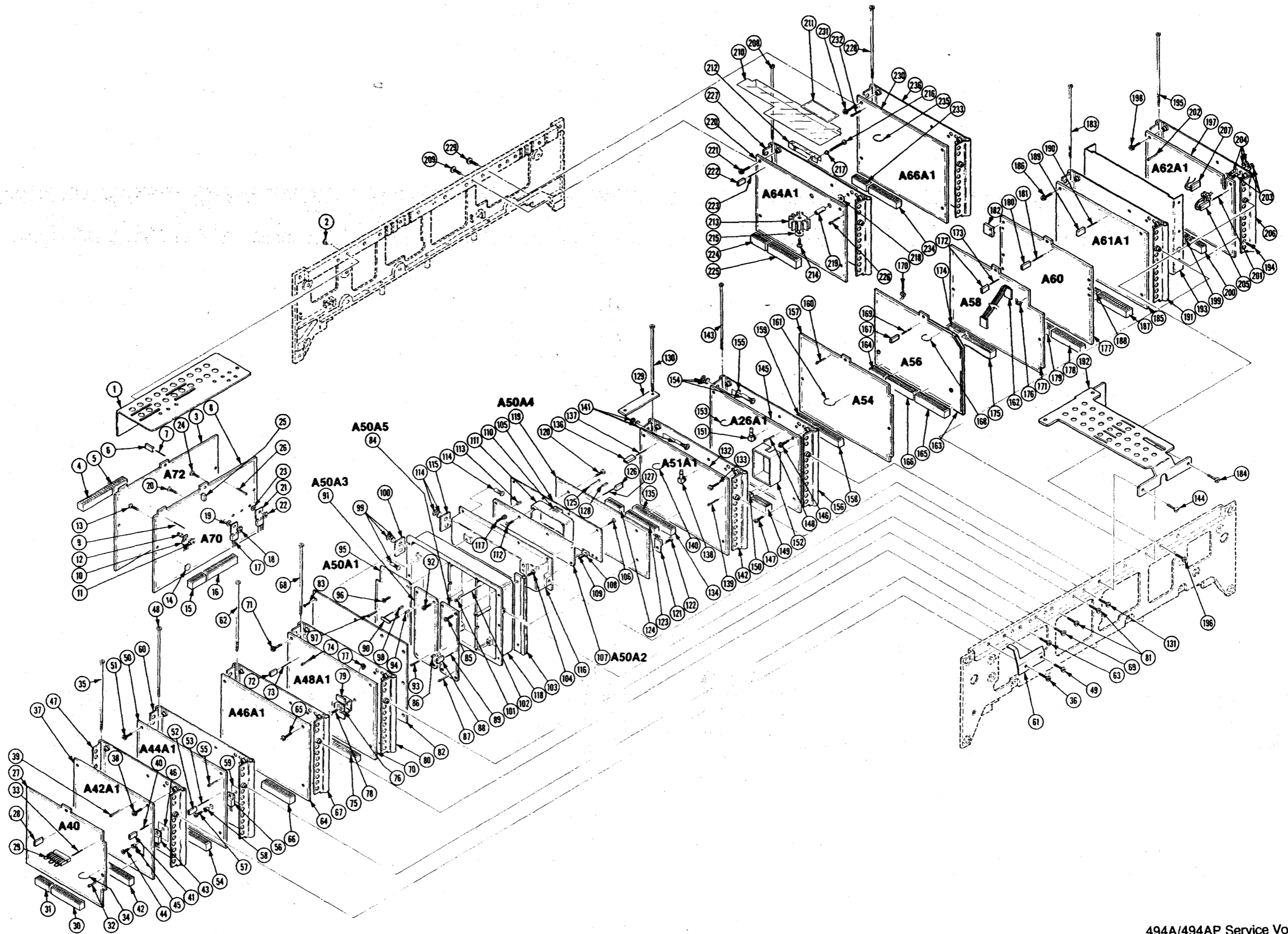

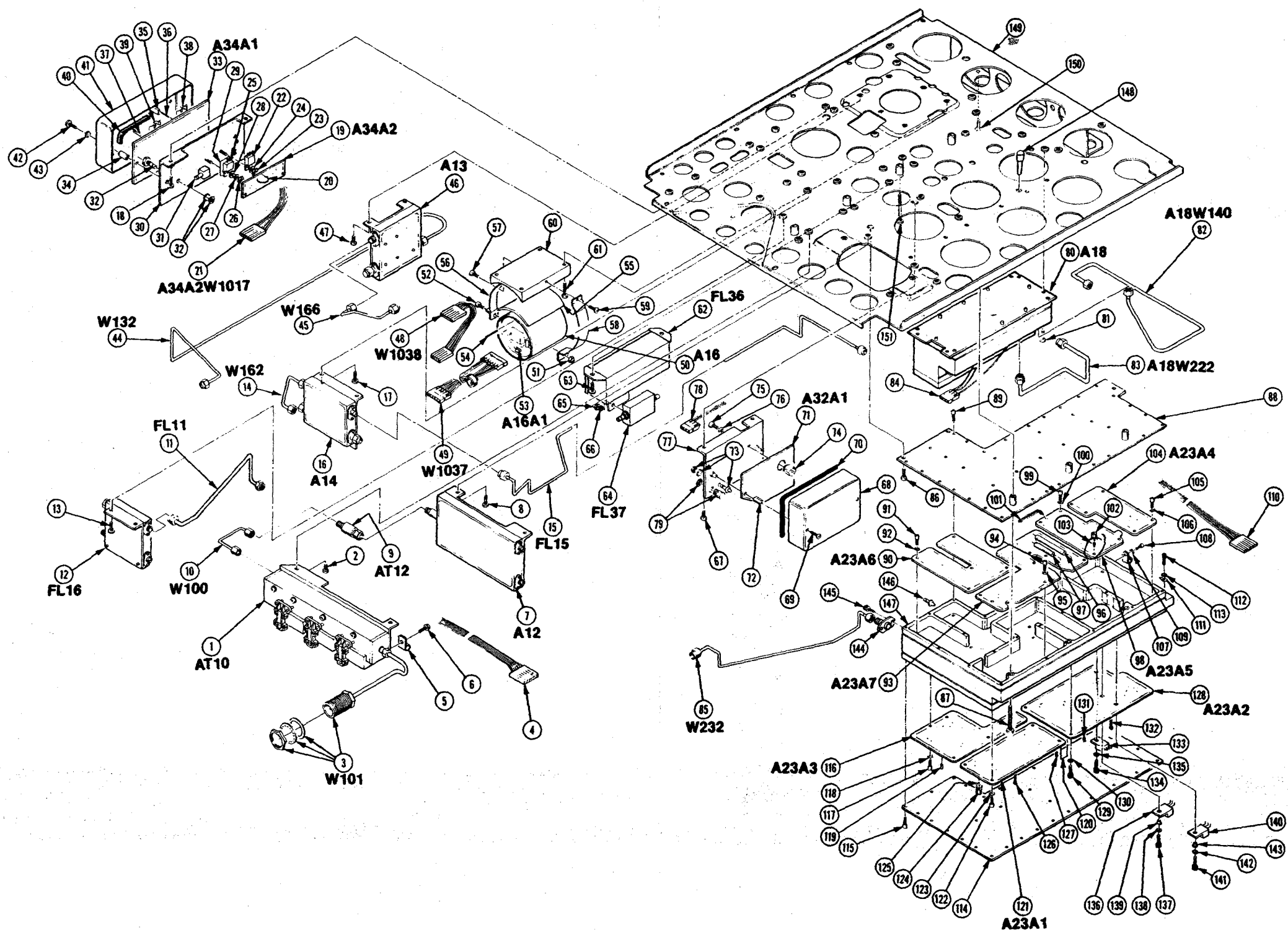

Replaceable Mechanical Parts
494A/494AP Service Vol.2

Fig. & Index No.	Tektronix Part No.	Serial/Assembly No.		Qty	12345 Name & Description	Mfr. Code	Mfr. Part No.
		Effective	Dscort				
4-	-----			1	VAR RESOLN MDL:(SEE A68 REPL) (ATTACHING PARTS)		
-1	211-0510-00			3	SCREW,MACHINE:6-32 X 0.375,PNH,STL (END ATTACHING PARTS)	83385	ORDER BY DESCR
-2	200-3381-00			1	VAR RESOLN MODULE INCLUDES: .COVER,ELEC:SHIELD VR II	80009	200-3381-00
-3	211-0162-01			14	.(ATTACHING PARTS) .SCREW,CAP:2-56 X 0.188,SCH,SST,HEX REC,W/NY .LON PATCH (END ATTACHING PARTS)	26233	ORDER BY DESCR
-4	342-0478-00			2	.INSULATOR,TERM:0.5 L,PLASTIC	80009	342-0478-00
-5	131-2364-00			2	.TERM,FEEDTHRU:U-SHP,0.462 L X 0.525 L	80009	131-2364-00
-6	-----			1	.CKT BOARD ASSY:BAND LEVELING (SEE A68A7 REPL) (ATTACHING PARTS) (END ATTACHING PARTS)		
-7					.CKT BOARD ASSY INCLUDES:		
	211-0007-01			4	.SCREW,MACHINE:4-40 X 0.188,PNH,STL	26233	ORDER BY DESCR
-8	136-0263-04			5	..SOCKET,PIN TERM:U/W 0.025 SQ PIN	80009	136-0263-04
-9	214-4085-00			2	..TERM,TEST POINT:0.070 ID,0.220 H,0.063 DIA ..PCB,0.015 X 0.032 BRASS,W/ RED NYLON COLLAR	26364	104-01-02
-10	131-0372-00			2	.CONN,RF PLUG:	80009	131-0372-00
-11	-----			1	.CKT BOARD ASSY:2ND FILTER SELECT (SEE A68A8 REPL) (ATTACHING PARTS) (END ATTACHING PARTS)		
-12					.CIRCUIT BOARD ASSY INCLUDES:		
	211-0007-01			4	.SCREW,MACHINE:4-40 X 0.188,PNH,STL	26233	ORDER BY DESCR
-13	136-0263-04			8	..SOCKET,PIN TERM:U/W 0.025 SQ PIN	80009	136-0263-04
-14	214-4085-00			2	..TERM,TEST POINT:0.070 ID,0.220 H,0.063 DIA ..PCB,0.015 X 0.032 BRASS,W/ RED NYLON COLLAR	26364	104-01-02
-15	346-0032-00			2	..STRAP,RETAINING:0.075 DIA X 4.0 L,MLD RBR	98159	2829-75-4
-16	-----			1	.CKT BOARD ASSY:POST VR AMPLIFIER (SEE A68A9 REPL) (ATTACHING PARTS)		
-17	211-0007-01			2	.SCREW,MACHINE:4-40 X 0.188,PNH,STL	26233	ORDER BY DESCR
-18	211-0101-01			1	.SCREW,MACHINE:4-40 X 0.25,FLH,100 DEG,STL (END ATTACHING PARTS) .CIRCUIT BOARD ASSY INCLUDES:	26233	ORDER BY DESCR
-19	136-0263-04			3	..SOCKET,PIN TERM:U/W 0.025 SQ PIN	80009	136-0263-04
-20	214-4085-00			2	..TERM,TEST POINT:0.070 ID,0.220 H,0.063 DIA ..PCB,0.015 X 0.032 BRASS,W/ RED NYLON COLLAR	26364	104-01-02
-21	346-0032-00			1	..STRAP,RETAINING:0.075 DIA X 4.0 L,MLD RBR	98159	2829-75-4
-22	214-2569-00			1	..HEAT SINK,XSTR:TO-5,CU BE	05820	260-4 TH5B
-23	407-2137-00			1	.BRACKET,HOUSING:RIGHT,ALUMINUM (ATTACHING PARTS)	80009	407-2137-00
-24	211-0541-00			1	.SCREW,MACHINE:6-32 X 0.25,FLH,100 DEG,STL (END ATTACHING PARTS)	93907	ORDER BY DESCR
-25	-----			1	.MICROCIRCUIT,LI:(SEE A68U3041 REPL) (ATTACHING PARTS)		
-26	211-0503-00			1	.SCREW,MACHINE:6-32 X 0.188,PNH,STL (END ATTACHING PARTS)	93907	ORDER BY DESCR
-27	380-0546-03			1	.HOUSING,CKT BD:VR2,ALUMINUM (ATTACHING PARTS)	80009	380-0546-03
-28	211-0514-00			3	.SCREW,MACHINE:6-32 X 0.750,PNH,STL	93907	B20-70350
-29	210-0006-00			3	.WASHER,LOCK:#6 INTL,0.018 THK,STL	77900	1206-00-00-0541C
-30	361-0917-00			3	.SPACER,SLEEVE:0.25 L X 0.141 ID,ALUMINUM (END ATTACHING PARTS)	80009	361-0917-00
-31	-----			1	.CKT BOARD ASSY:#2 V.R. MOTHER (SEE A68A2 REPL) (ATTACHING PARTS)		
-32	211-0341-00			12	.SCREW,MACHINE:2-56 X 0.188,STL (END ATTACHING PARTS) .CKT BOARD ASSY INCLUDES:	83385	ORDER BY DESCR
-33	131-0787-00			12	..TERMINAL,PIN:	22526	47359-001
-34	131-2196-00			1	..CONN,BOX:	80009	131-2196-00
-35	131-2167-00			1	..CONN,BOX:	80009	131-2167-00
-36	-----			1	.CKT BOARD ASSY:#1 V.R. MOTHER		

Replaceable Mechanical Parts
494A/494AP Service Vol.2

Fig. & Index No.	Tektronix Part No.	Serial/Assembly No. Effective Discnt	Qty	12345 Name & Description	Mfr. Code	Mfr. Part No.
4-				.(SEE A68A1 REPL) .(ATTACHING PARTS)		
-37	211-0341-00		18	.SCREW,MACHINE:2-56 X 0.188,STL .(END ATTACHING PARTS) .CKT BOARD ASSY INCLUDES:	83385	ORDER BY DESCR
-38	131-0787-00		21	.. TERMINAL,PIN:	22526	47359-001
-39	131-2167-00		1	.. CONN,BOX:	80009	131-2167-00
-40	407-2138-00		1	.BRACKET,HOUSING:LEFT,ALUMINUM .(ATTACHING PARTS)	80009	407-2138-00
-41	211-0541-00		2	.SCREW,MACHINE:6-32 X 0.25,FLH,100 DEG,STL .(END ATTACHING PARTS)	93907	ORDER BY DESCR
-42	200-3380-00		1	.COVER,ELEC:SHIELD VR I .(ATTACHING PARTS)	80009	200-3380-00
-43	211-0030-00		2	.SCREW,MACHINE:2-56 X 0.25,FLH,82 DEG,STL .(END ATTACHING PARTS)	93907	ORDER BY DESCR
-44	211-0162-01		17	.SCREW,CAP:2-56 X 0.188,SCH,SST,HEX REC,W/NY .LON PATCH	26233	ORDER BY DESCR
-45	131-2364-00		3	.TERM,FEEDTHRU:U-SHP,0.462 L X 0.525 L	80009	131-2364-00
-46	342-0478-00		3	.INSULATOR,TERM:0.5 L,PLASTIC	80009	342-0478-00
-47	-----		1	.CKT BOARD ASSY:200B GAIN STEPS .(SEE A68A6 REPL) .(ATTACHING PARTS) .(END ATTACHING PARTS) .CKT BOARD ASSY INCLUDES:		
-48	211-0007-01		4	.SCREW,MACHINE:4-40 X 0.188,PNH,STL	26233	ORDER BY DESCR
-49	136-0263-04		7	.. SOCKET,PIN TERM:U/W 0.025 SQ PIN	80009	136-0263-04
-50	214-4085-00		1	.. TERM,TEST POINT:0.070 ID,0.220 H,0.063 DIA .. PCB,0.015 X 0.032 BRASS,W/ RED NYLON COLLAR	26364	104-01-02
-51	-----		1	.CKT BOARD ASSY:10DB GAIN STEPS .(SEE A68A5 REPL) .(ATTACHING PARTS) .(END ATTACHING PARTS) .CKT BOARD ASSY INCLUDES:		
-52	211-0007-01		4	.SCREW,MACHINE:4-40 X 0.188,PNH,STL	26233	ORDER BY DESCR
-53	214-4085-00		2	.. TERM,TEST POINT:0.070 ID,0.220 H,0.063 DIA .. PCB,0.015 X 0.032 BRASS,W/ RED NYLON COLLAR	26364	104-01-02
-54	136-0263-04		8	.. SOCKET,PIN TERM:U/W 0.025 SQ PIN	80009	136-0263-04
-55	-----		1	.CKT BOARD ASSY:1ST FILTER SELECT .(SEE A68A4 REPL) .(ATTACHING PARTS) .(END ATTACHING PARTS) .CKT BOARD ASSY INCLUDES:		
-56	211-0007-01		4	.SCREW,MACHINE:4-40 X 0.188,PNH,STL	26233	ORDER BY DESCR
-57	136-0263-04		10	.. SOCKET,PIN TERM:U/W 0.025 SQ PIN	80009	136-0263-04
-58	346-0032-00		2	.. STRAP,RETAINING:0.075 DIA X 4.0 L,MLD RBR	98159	2829-75-4
-59	214-4085-00		2	.. TERM,TEST POINT:0.070 ID,0.220 H,0.063 DIA .. PCB,0.015 X 0.032 BRASS,W/ RED NYLON COLLAR	26364	104-01-02
-60	-----		1	.CKT BOARD ASSY:VR INPUT .(SEE A68A3 REPL) .(ATTACHING PARTS)		
-61	211-0007-01		4	.SCREW,MACHINE:4-40 X 0.188,PNH,STL	26233	ORDER BY DESCR
-62	211-0101-00		1	.SCREW,MACHINE:4-40 X 0.25,FLH,100 DEG,STL .(END ATTACHING PARTS) .CKT BOARD ASSY INCLUDES:	93907	ORDER BY DESCR
-63	214-4085-00		1	.. TERM,TEST POINT:0.070 ID,0.220 H,0.063 DIA .. PCB,0.015 X 0.032 BRASS,W/ RED NYLON COLLAR	26364	104-01-02
-64	136-0263-04		2	.. SOCKET,PIN TERM:U/W 0.025 SQ PIN	80009	136-0263-04
-65	214-2569-00		1	.. HEAT SINK,XSTR:TO-5,CU BE	05820	260-4 TH5B
-66	131-0372-00		4	.CONN,RF PLUG:	80009	131-0372-00
-67	380-0547-03		1	.HOUSING,CKT BD:VR1,ALUMINUM .(ATTACHING PARTS)	80009	380-0547-03
-68	426-2109-01		1	CHAS ASSY,INNER:SPECTRUM ANALYZER	80009	426-2109-01
-69	211-0507-02		1	.SCREW,MACHINE:6-32 X 0.312,PNH,STL	26233	ORDER BY DESCR
-70	210-0457-00		2	NUT,PL,ASSEM WA:6-32 X 0.312,STL CD PL .(END ATTACHING PARTS)	78189	511-061800-00
-71	214-2772-03		1	ACTUATOR,SWITCH:POWER	80009	214-2772-03
-72	384-1248-00		1	SHAFT,SWITCH:14.40 L X 0.125 OD,AL	80009	384-1248-00
-73	214-1801-00		1	ACTUATOR,LATCH:PUSH/PUSH	80009	214-1801-00

Replaceable Mechanical Parts
494A/494AP Service Vol.2

Fig. & Index No.	Tektronix Part No.	Serial/Assembly No. Effective Dscont	Qty	12345 Name & Description	Mfr. Code	Mfr. Part No.
4-				(ATTACHING PARTS)		
-74	211-0510-00		1	SCREW,MACHINE:6-32 X 0.375,PNH,STL (END ATTACHING PARTS)	83385	ORDER BY DESCR
-75	366-2067-00		1	PUSH BUTTON:MEDIUM GRAY,1.400 X 0.235 (ATTACHING PARTS)	80009	366-2067-00
-76	211-0097-01		1	SCREW,MACHINE:4-40 X 0.312,PNH,STL	26233	ORDER BY DESCR
-77	210-1001-00		1	WASHER,FLAT:0.119 ID X 0.375 OD X 0.021 (END ATTACHING PARTS)	12360	ORDER BY DESCR
-78	343-1127-00		1	CLAMP,RIM CLENC:ACTUATOR,STEEL (ATTACHING PARTS)	80009	343-1127-00
-79	210-0586-00		1	NUT,PL,ASSEM WA:4-40 X 0.25,STL CD PL (END ATTACHING PARTS)	78189	211-041800-00
-80	344-0359-00		1	CLIP,RETAINING:ACTUATOR,ALUMINUM	80009	344-0359-00
-81	351-0577-00		1	GUIDE,CKT BOARD:AL,2.9 L (ATTACHING PARTS)	80009	351-0577-00
-82	211-0504-00		2	SCREW,MACHINE:6-32 X 0.250,PNH,STL (END ATTACHING PARTS)	TK0435	ORDER BY DESCR
-83	351-0561-00		1	GUIDE,CKT BOARD:BLACK POLYPROPYLENE	80009	351-0561-00
	-----		1	FILTER,DUAL BW:(SEE A69 REPL) (ATTACHING PARTS)		
-84	211-0503-00		4	SCREW,MACHINE:6-32 X 0.188,PNH,STL (END ATTACHING PARTS)	93907	ORDER BY DESCR
-85	407-3586-00		4	FILTER,DUAL BW INCLUDES: .BRACKET,MTG:ALUMINUM (ATTACHING PARTS)	80009	407-3586-00
-86	211-0503-00		8	.SCREW,MACHINE:6-32 X 0.188,PNH,STL	93907	ORDER BY DESCR
-87	210-0055-00		8	.WASHER,LOCK:#6 SPLIT,0.031 THK,STL (END ATTACHING PARTS)	81350	ORDER BY DESCR
-88	174-0706-00		1	.CA ASSY,SP,ELEC:2,26 AWG,10.0 L	80009	174-0706-00
-89	200-3400-00		1	.COVER,FILTER: (ATTACHING PARTS)	80009	200-3400-00
-90	211-0087-01		12	.SCREW,MACHINE:2-56 X 0.188,FLH,82 DEG,STL (END ATTACHING PARTS)	TK0435	ORDER BY DESCR
-91	342-0811-00		14	.INSULATOR,TERM:0.225 L,PLASTIC	80009	342-0811-00
-92	131-3962-00		2	.TERM,FEEDTHRU:0.575 L X 0.012 DIA,BRASS,GOL .D PLATED	80009	131-3962-00
-93	-----		1	.CKT BOARD ASSY:LOCAL OSC(SEE A69A4 REPL) (ATTACHING PARTS)		
-94	211-0022-00		2	.SCREW,MACHINE:2-56 X 0.188,PNH,STL (END ATTACHING PARTS)	TK0435	ORDER BY DESCR
-95	253-0176-00		1	.CKT BOARD ASSY INCLUDES: .TAPE,PRESS SENS:VINYL FOAM,0.5 X 0.062,	85471	ORDER BY DESCR
-96	136-0263-04		5	.SOCKET,PIN TERM:U/W 0.025 SQ PIN	80009	136-0263-04
-97	-----		1	.CKT BOARD ASSY:2ND MIXER(SEE A69A3 REPL) (ATTACHING PARTS)		
-98	211-0022-00		2	.SCREW,MACHINE:2-56 X 0.188,PNH,STL (END ATTACHING PARTS)	TK0435	ORDER BY DESCR
-99	136-0263-04		6	.CKT BOARD ASSY INCLUDES: .SOCKET,PIN TERM:U/W 0.025 SQ PIN	80009	136-0263-04
-100	346-0032-00		2	.STRAP,RETAINING:0.075 DIA X 4.0 L,MLD RBR	98159	2829-75-4
-101	-----		1	.CKT BOARD ASSY:BAND PASS FILTER (SEE A69A2 REPL) (ATTACHING PARTS)		
-102	211-0022-00		4	.SCREW,MACHINE:2-56 X 0.188,PNH,STL (END ATTACHING PARTS)	TK0435	ORDER BY DESCR
-103	-----		3	.CKT BOARD ASSY INCLUDES: .CKT BOARD ASSY:CRYSTAL(SEE A69A2A1, .A69A2A2,A69A2A3 REPL)		
-104	136-0328-03		6	...SOCKET,CONTACT:PCB,;FEMALE,RTANG,DESCRETE,S ...IDE ENTRY,40 GOLD,ACCOM 0.025 SQ PINS;,,	80009	136-0328-03
-105	136-0234-00		6	...SOCKET,PIN TERM:	00779	380598-1
-106	342-0814-00		3	.INSULATOR,PLATE:0.75 L X 0.38,MYLAR	80009	342-0814-00
-107	346-0032-00		2	.STRAP,RETAINING:0.075 DIA X 4.0 L,MLD RBR	98159	2829-75-4
-108	136-0263-04		28	.SOCKET,PIN TERM:U/W 0.025 SQ PIN	80009	136-0263-04
	131-1343-00		1	.CONN,HDR::PCB,;MALE,STR,1 X 36,0.1 CTR,0.23 .0 MLG X 0.195 TAIL,30 GOLD;,,	TK1483	082-3643-SS02
-109	131-3964-00		11	.TERM,FEEDTHRU:0.3 L X 0.012 DIA,BRASS,GOLD .PLATED	80009	131-3964-00

Replaceable Mechanical Parts
494A/494AP Service Vol.2

Fig. & Index No.	Tektronix Part No.	Serial/Assembly No.		Qty	12345 Name & Description	Mfr.	
		Effective	Discnt			Code	Mfr. Part No.
4-110	131-3963-00			1	.TERM,FEEDTHRU:0.5 L X 0.012 DIA,BRASS,GOLD PLATED	80009	131-3963-00
-111	-----			1	.CKT BOARD ASSY:1ST MIXER(SEE A69A1 REPL) (ATTACHING PARTS)		
-112	211-0022-00			2	.SCREW,MACHINE:2-56 X 0.188,PNH,STL (END ATTACHING PARTS) .CKT BOARD ASSY INCLUDES:	TK0435	ORDER BY DESCR
-113	136-0263-04			6	.SOCKET,PIN TERM:U/W 0.025 SQ PIN	80009	136-0263-04
-114	380-0837-00			1	.HOUSING,FILTER:10HZ	80009	380-0837-00
-115	407-3587-00			1	BRACKET,MTG:ALUMINUM (ATTACHING PARTS)	80009	407-3587-00
-116	211-0507-00			2	SCREW,MACHINE:6-32 X 0.312,PNH,STL (END ATTACHING PARTS)	83385	ORDER BY DESCR
-117	407-3585-00			1	BRACKET,MTG:ALUMINUM (ATTACHING PARTS)	80009	407-3585-00
-118	210-0457-00			2	NUT,PL,ASSEM WA:6-32 X 0.312,STL CD PL (END ATTACHING PARTS)	78189	511-061800-00
-119	200-2220-01	B010100	B020628	1	GUARD,CKT BOARD:POLYCARBONATE	80009	200-2220-01
	200-2220-02	B020629		1	GUARD,CKT BD:POLYCARBONATE	80009	200-2220-02
-120	334-2257-01			1	.MARKER,IDENT:MARKED CAUTION	80009	334-2257-01
-121	-----			1	CKT BOARD ASSY:HIGH VOLTAGE(SEE A74 REPL) (ATTACHING PARTS)		
-122	211-0097-01			2	SCREW,MACHINE:4-40 X 0.312,PNH,STL	26233	ORDER BY DESCR
-123	211-0025-00			1	SCREW,MACHINE:4-40 X 0.375,FLH,100 DEG,STL (END ATTACHING PARTS) CKT BOARD ASSY INCLUDES:	TK0435	ORDER BY DESCR
-124	-----			1	.TRANSISTOR:(SEE A74Q1073 REPL) (ATTACHING PARTS)		
-125	211-0507-00			1	.SCREW,MACHINE:6-32 X 0.312,PNH,STL	83385	ORDER BY DESCR
-126	385-0107-00			1	.SPACER,POST:0.75 L W/4-40 THD THRU,NYL	80009	385-0107-00
-127	210-0054-00			1	.WASHER,LOCK:#4 SPLIT,0.025 THK STL	78189	ORDER BY DESCR
-128	210-1171-00			1	.WASHER,SHLDR:0.12 ID X 0.143 OD X 0.07 D (END ATTACHING PARTS)	00261	A7148516P2
-129	342-0354-00			1	.INSULATOR,PLATE:TRANSISTOR	55285	7403-09FR-52
-130	131-2196-00			1	.CONN,BOX:	80009	131-2196-00
-131	214-4085-00			1	.TERM,TEST POINT:0.070 ID,0.220 H,0.063 DIA .PCB,0.015 X 0.032 BRASS,W/ RED NYLON COLLAR	26364	104-01-02
-132	131-0608-00			7	.TERMINAL,PIN:0.365 L X 0.025 BRZ GLD PL	80009	131-0608-00
-133	131-0993-00			1	.CONN,BOX:SHUNT/SHORTING,;FEMALE,STR,1 X 2,0 .1 CTR,0.385 H,30 GOLD,BLACK,JUMPER;	22526	65474-006
-134	-----			1	.CKT BOARD ASSY:HIGH VOLTAGE (SEE A74A1 REPL) (ATTACHING PARTS)		
-135	210-0406-00			2	.NUT,PLAIN,HEX:4-40 X 0.188,BRS CD PL (END ATTACHING PARTS)	73743	12161-50
-136	384-0531-00			1	SPACER,POST:0.656 L,0.25 DIA,NYLON	80009	384-0531-00
-137	337-3391-00	B010100	B010326	1	SHIELD,ELEC:HIGH VOLTAGE	80009	337-3391-00
	337-3391-01	B010327		1	SHIELD,ELEC:HIGH VOLTAGE (ATTACHING PARTS)	80009	337-3391-01
-138	210-0586-00			2	NUT,PL,ASSEM WA:4-40 X 0.25,STL CD PL	78189	211-041800-00
-139	211-0510-00			2	SCREW,MACHINE:6-32 X 0.375,PNH,STL (END ATTACHING PARTS) HIGH VOLTAGE SHIELD INCLUDES:	83385	ORDER BY DESCR
-140	342-0507-00			1	.INSULATOR,PLATE:HIGH VOLTAGE	80009	342-0507-00
-141	342-0094-00			1	.INSULATOR,PLATE:SHIELD,POLYESTER	80009	342-0094-00
-142	351-0559-00			1	GUIDE,CKT BOARD:ALUMINUM (ATTACHING PARTS)	80009	351-0559-00
-143	211-0507-00			1	SCREW,MACHINE:6-32 X 0.312,PNH,STL (END ATTACHING PARTS)	83385	ORDER BY DESCR
-144	-----			1	CKT BOARD ASSY:MAIN (SEE A28 REPL) (ATTACHING PARTS)		
-145	211-0601-00			14	SCR,ASSEM WSHR:6-32 X 0.312,PNH,BRS NP,POZ (END ATTACHING PARTS) CKT BOARD ASSY INCLUDES:	TK0435	ORDER BY DESCR
-146	131-0608-00			80	.TERMINAL,PIN:0.365 L X 0.025 BRZ GLD PL	80009	131-0608-00
-147	131-0589-00			994	.TERMINAL,PIN:	22526	48283-087
-148	346-0032-00			1	.STRAP,RETAINING:0.075 DIA X 4.0 L,MLD RBR	98159	2829-75-4
-149	426-2097-00			2	FR SECTION,SA:SIDE	80009	426-2097-00

Replaceable Mechanical Parts
494A/494AP Service Vol.2

Fig. & Index No.	Tektronix Part No.	Serial/Assembly No.		Qty	12345 Name & Description	Mfr.	
		Effective	Dscont			Code	Mfr. Part No.
5-1	407-3384-00			1	BRACKET,ANGLE:CIRCUIT BOARD (ATTACHING PARTS)	80009	407-3384-00
-2	211-0507-00			2	SCREW,MACHINE:6-32 X 0.312,PNH,STL (END ATTACHING PARTS)	83385	ORDER BY DESCR
-3	-----			1	CKT BOARD ASSY:SWEEP(SEE A72 REPL)		
-4	131-2167-00			2	.CONN,BOX:	80009	131-2167-00
-5	131-2196-00			1	.CONN,BOX:	80009	131-2196-00
-6	131-0993-00			3	.CONN,BOX:SHUNT/SHORTING,;FEMALE,STR,1 X 2,0 ..1 CTR,0.385 H,30 GOLD,BLACK,JUMPER;	22526	65474-006
-7	131-0608-00			6	.TERMINAL,PIN:0.365 L X 0.025 BRZ GLD PL	80009	131-0608-00
-8	-----			1	CKT BOARD ASSY:Z AXIS(SEE A70 REPL)		
-9	131-0608-00			11	.TERMINAL,PIN:0.365 L X 0.025 BRZ GLD PL	80009	131-0608-00
-10	131-0589-00			3	.TERMINAL,PIN:	22526	48283-087
-11	210-0586-00			1	.TRANSISTOR:(SEE A70Q3028 REPL) (ATTACHING PARTS)		
-12	210-1133-00			1	.NUT,PL,ASSEM WA:4-40 X 0.25,STL CD PL	78189	211-041800-00
-13	211-0097-01			1	.WASHER,FLAT:0.142 ID X 0.25 OD X0.058,FBR .SCREW,MACHINE:4-40 X 0.312,PNH,STL (END ATTACHING PARTS)	86928 26233	ORDER BY DESCR ORDER BY DESCR
-14	386-1130-00			2	.INSULATOR,DISK:TRANSISTOR,NYLON	80009	386-1130-00
-15	131-2196-00			1	.CONN,BOX:	80009	131-2196-00
-16	131-2167-00			2	.CONN,BOX:	80009	131-2167-00
-17	-----			1	.TRANSISTOR:(SEE A70Q4058 REPL) (ATTACHING PARTS)		
-18	210-0586-00			1	.NUT,PL,ASSEM WA:4-40 X 0.25,STL CD PL	78189	211-041800-00
-19	361-0020-00			1	.INSULATOR,WSHR:0.156 ID X 0.3 OD X 0.78	80009	361-0020-00
-20	211-0097-01			1	.SCREW,MACHINE:4-40 X 0.312,PNH,STL (END ATTACHING PARTS)	26233	ORDER BY DESCR
-21	-----			1	.TRANSISTOR:(SEE A70Q4059 REPL) (ATTACHING PARTS)		
-22	210-0586-00			1	.NUT,PL,ASSEM WA:4-40 X 0.25,STL CD PL	78189	211-041800-00
-23	361-0020-00			1	.INSULATOR,WSHR:0.156 ID X 0.3 OD X 0.78	80009	361-0020-00
-24	211-0097-01			1	.SCREW,MACHINE:4-40 X 0.312,PNH,STL (END ATTACHING PARTS)	26233	ORDER BY DESCR
-25	136-0544-00			10	.JACK,TIP:U/W 0.08 DIA PIN,WHITE	74970	105-1101-001
-26	214-4085-00			2	.TERM,TEST POINT:0.070 ID,0.220 H,0.063 DIA .PCB,0.015 X 0.032 BRASS,W/ RED NYLON COLLAR	26364	104-01-02
-27	-----			1	CKT BOARD ASSY:VIDEO PROCESSOR (SEE A40 REPL)		
-28	131-0993-09			1	.BUS,CONDUCTOR:SHUNT ASSEMBLY,WHITE	00779	850100-1
-29	131-2053-00			1	.BUS,CONDUCTOR:3,26 AWG,1.5 L	TK1375	131-2053-00
-30	352-0166-00			1	.HLDR,TERM CONN:8 WIRE,BLACK	80009	352-0166-00
-31	131-2167-00			1	.CONN,BOX:	80009	131-2167-00
-32	131-2196-00			1	.CONN,BOX:	80009	131-2196-00
-33	214-4085-00			11	.TERM,TEST POINT:0.070 ID,0.220 H,0.063 DIA .PCB,0.015 X 0.032 BRASS,W/ RED NYLON COLLAR	26364	104-01-02
-34	131-0608-00			11	.TERMINAL,PIN:0.365 L X 0.025 BRZ GLD PL	80009	131-0608-00
-35	346-0032-00			3	.STRAP,RETAINING:0.075 DIA X 4.0 L,MLD RBR	98159	2829-75-4
-36	-----			1	CKT BOARD ASSY:PRESELECTOR(SEE A42 REPL) (OPTION 01 ONLY) (ATTACHING PARTS)		
-37	211-0666-00			2	SCREW,MACHINE:6-32 X 4.25,PNH,STL	83486	ORDER BY DESCR
-38	211-0507-00			1	SCREW,MACHINE:6-32 X 0.312,PNH,STL (END ATTACHING PARTS) CKT BOARD ASSY INCLUDES:	83385	ORDER BY DESCR
-39	-----			1	.CKT BOARD ASSY:PRESELECTOR DRIVE (SEE A42A1 REPL) (ATTACHING PARTS)		
-40	211-0116-00			4	.SCR,ASSEM WSHR:4-40 X 0.312,PNH,BRS,NP,POZ (END ATTACHING PARTS) CKT BOARD ASSY INCLUDES:	77900	ORDER BY DESCR
-41	214-4085-00			5	.TERM,TEST POINT:0.070 ID,0.220 H,0.063 DIA .PCB,0.015 X 0.032 BRASS,W/ RED NYLON COLLAR	26364	104-01-02
-42	131-0608-00			10	.TERMINAL,PIN:0.365 L X 0.025 BRZ GLD PL	80009	131-0608-00
-43	131-0993-00			4	.CONN,BOX:SHUNT/SHORTING,;FEMALE,STR,1 X 2,0 ..1 CTR,0.385 H,30 GOLD,BLACK,JUMPER;	22526	65474-006
-44	131-2167-00			2	.CONN,BOX:	80009	131-2167-00
-45	-----			1	.TRANSISTOR:(SEE A42Q565 REPL)		

Replaceable Mechanical Parts
494A/494AP Service Vol.2

Fig. & Index No.	Tektronix Part No.	Serial/Assembly No. Effective Dscort	Qty	12345 Name & Description	Mfr. Code	Mfr. Part No.
5-				.(ATTACHING PARTS)		
-44	211-0008-01		1	.SCREW,MACHINE:4-40 X 0.25,PNH,STL	26233	ORDER BY DESCR
-45	210-1178-00		1	.WASHER,SHLDR: .(END ATTACHING PARTS)	80009	210-1178-00
-46	342-0354-00		1	.INSULATOR,PLATE:TRANSISTOR	55285	7403-09FR-52
-47				CKT BOARD ASSY:1ST LO DRIVER(SEE A44 REPL) (ATTACHING PARTS)		
	352-0782-00		1	.HOLDER,CKT BD:ALUMINUM	80009	352-0782-00
-48	211-0666-00		2	SCREW,MACHINE:6-32 X 4.25,PNH,STL	83486	ORDER BY DESCR
-49	211-0507-00		1	SCREW,MACHINE:6-32 X 0.312,PNH,STL (END ATTACHING PARTS)	83385	ORDER BY DESCR
-50	-----		1	CKT BOARD ASSY INCLUDES: .CKT BOARD ASSY:1ST LO DRIVE (SEE A44A1 REPL) (ATTACHING PARTS)		
-51	211-0116-00		4	.SCR,ASSEM WSHR:4-40 X 0.312,PNH,BRS,NP,POZ (END ATTACHING PARTS)	77900	ORDER BY DESCR
-52	131-0993-00		1	.CONN,BOX:SHUNT/SHORTING,;FEMALE,STR,1 X 2,0 ...1 CTR,0.385 H,30 GOLD,BLACK,JUMPER;	22526	65474-006
-53	131-0608-00		2	.TERMINAL,PIN:0.365 L X 0.025 BRZ GLD PL	80009	131-0608-00
-54	131-2167-00		2	.CONN,BOX:	80009	131-2167-00
-55	214-4085-00		3	.TERM,TEST POINT:0.070 ID,0.220 H,0.063 DIA .PCB,0.015 X 0.032 BRASS,W/ RED NYLON COLLAR	26364	104-01-02
-56	-----		1	.TRANSISTOR:(SEE A44Q352) (ATTACHING PARTS)		
-57	211-0008-01		1	.SCREW,MACHINE:4-40 X 0.25,PNH,STL	26233	ORDER BY DESCR
-58	210-1178-00		1	.WASHER,SHLDR: .(END ATTACHING PARTS)	80009	210-1178-00
-59	342-0355-00		1	.INSULATOR,PLATE:TRANSISTOR,SILICONE RUBBER	55285	7403-09FR-51
-60	352-0512-05		1	.HOLDER,CKT BD:ALUMINUM	80009	352-0512-05
-61	407-2784-00		1	BRACKET,RTNG:CIRCUIT BOARD,AL	80009	407-2784-00
	-----		1	CKT BOARD ASSY:CENTER FREQ CONTROL (SEE A46 REPL) (ATTACHING PARTS)		
-62	211-0666-00		2	SCREW,MACHINE:6-32 X 4.25,PNH,STL	83486	ORDER BY DESCR
-63	211-0507-02		1	SCREW,MACHINE:6-32 X 0.312,PNH,STL (END ATTACHING PARTS)	26233	ORDER BY DESCR
-64	-----		1	CKT BOARD ASSY:CENTER FREQ CONTROL (SEE A46A1 REPL) (ATTACHING PARTS)		
-65	211-0116-00		2	.SCR,ASSEM WSHR:4-40 X 0.312,PNH,BRS,NP,POZ (END ATTACHING PARTS)	77900	ORDER BY DESCR
-66	131-2167-00		2	.CONN,BOX:	80009	131-2167-00
-67	352-0512-05		1	.HOLDER,CKT BD:ALUMINUM	80009	352-0512-05
	-----		1	CKT BOARD ASSY:SPAN ATTN(SEE A48 REPL) (ATTACHING PARTS)		
-68	211-0666-00		2	SCREW,MACHINE:6-32 X 4.25,PNH,STL	83486	ORDER BY DESCR
-69	211-0507-00		1	SCREW,MACHINE:6-32 X 0.312,PNH,STL (END ATTACHING PARTS)	83385	ORDER BY DESCR
-70	-----		1	CKT BOARD ASSY:SPAN ATTENUATOR (SEE A48A1 REPL) (ATTACHING PARTS)		
-71	211-0116-00		4	.SCR,ASSEM WSHR:4-40 X 0.312,PNH,BRS,NP,POZ (END ATTACHING PARTS)	77900	ORDER BY DESCR
-72	131-0993-00		1	.CONN,BOX:SHUNT/SHORTING,;FEMALE,STR,1 X 2,0 ...1 CTR,0.385 H,30 GOLD,BLACK,JUMPER;	22526	65474-006
-73	131-0608-00		2	.TERMINAL,PIN:0.365 L X 0.025 BRZ GLD PL	80009	131-0608-00
-74	214-4085-00		2	.TERM,TEST POINT:0.070 ID,0.220 H,0.063 DIA .PCB,0.015 X 0.032 BRASS,W/ RED NYLON COLLAR	26364	104-01-02
-75	131-2167-00		2	.CONN,BOX:	80009	131-2167-00
-76	-----		2	.TRANSISTOR:(SEE A48A1Q2062, .A48A1Q3056 REPL) (ATTACHING PARTS)		
-77	210-0586-00		2	.NUT,PL,ASSEM WA:4-40 X 0.25,STL CD PL	78189	211-041800-00
-78	211-0008-00		2	.SCREW,MACHINE:4-40 X 0.25,PNH,STL	93907	ORDER BY DESCR

Replaceable Mechanical Parts
494A/494AP Service Vol.2

Fig. & Index No.	Tektronix Part No.	Serial/Assembly No.		Qty	12345 Name & Description	Mfr.	
		Effective	Dscort			Code	Mfr. Part No.
5-79	214-1845-01			2	..HEAT SINK,XSTR:0.125 DIA HOLE,AL ..(END ATTACHING PARTS)	80009	214-1845-01
-80	352-0512-05			1	..HOLDER,CKT BD:ALUMINUM	80009	352-0512-05
	-----			1	PHASE LOCK ASSY:SYNTHESIZER(SEE A50 REPL) (ATTACHING PARTS)		
-81	211-0507-00			4	SCREW,MACHINE:6-32 X 0.312,PNH,STL (END ATTACHING PARTS)	83385	ORDER BY DESCR
					PHASE LOCK ASSY INCLUDES:		
-82	200-2242-00			1	..COV,PH LOCK SYN:FRONT (ATTACHING PARTS)	80009	200-2242-00
-83	211-0087-01			12	..SCREW,MACHINE:2-56 X 0.188,FLH,82 DEG,STL (END ATTACHING PARTS)	TK0435	ORDER BY DESCR
-84	-----			1	..CKT BOARD ASSY:CONTROLLED OSCILLATOR (SEE A50A5 REPL) (ATTACHING PARTS)		
-85	211-0007-01			4	..SCREW,MACHINE:4-40 X 0.188,PNH,STL (END ATTACHING PARTS)	26233	ORDER BY DESCR
					..CKT BOARD ASSY INCLUDES:		
-86	136-0263-04			4	..SOCKET,PIN TERM:U/W 0.025 SQ PIN	80009	136-0263-04
-87	214-4085-00			2	..TERM,TEST POINT:0.070 ID,0.220 H,0.063 DIA ..PCB,0.015 X 0.032 BRASS,W/ RED NYLON COLLAR	26364	104-01-02
-88	131-0993-00			2	..CONN,BOX:SHUNT/SHORTING,;FEMALE,STR,1 X 2,0 ..1 CTR,0.385 H,30 GOLD,BLACK,JUMPER;	22526	65474-006
-89	131-0608-00			7	..TERMINAL,PIN:0.365 L X 0.025 BRZ GLD PL	80009	131-0608-00
-90	131-1612-03			3	..TERM,FEEDTHRU:U-SHP,0.3 L X 0.35 L X 0.25	80009	131-1612-03
	131-1612-06			3	..TERM,FEEDTHRU:U-SHP,0.55 L X 0.25 SQ BRS	80009	131-1612-06
-91	-----			1	..CKT BOARD ASSY:OFFSET MIXER (SEE A50A3 REPL) (ATTACHING PARTS)		
-92	211-0007-01			4	..SCREW,MACHINE:4-40 X 0.188,PNH,STL (END ATTACHING PARTS)	26233	ORDER BY DESCR
					..CKT BOARD ASSY INCLUDES:		
-93	214-4085-00			2	..TERM,TEST POINT:0.070 ID,0.220 H,0.063 DIA ..PCB,0.015 X 0.032 BRASS,W/ RED NYLON COLLAR	26364	104-01-02
-94	136-0263-04			6	..SOCKET,PIN TERM:U/W 0.025 SQ PIN	80009	136-0263-04
-95	-----			1	..CKT BOARD ASSY:SYNTHESIZER (SEE A50A1 REPL) (ATTACHING PARTS)		
-96	211-0007-01			3	..SCREW,MACHINE:4-40 X 0.188,PNH,STL (END ATTACHING PARTS)	26233	ORDER BY DESCR
					..CKT BOARD ASSY INCLUDES:		
-97	214-4085-00			3	..TERM,TEST POINT:0.070 ID,0.220 H,0.063 DIA ..PCB,0.015 X 0.032 BRASS,W/ RED NYLON COLLAR	26364	104-01-02
-98	136-0263-04			6	..SOCKET,PIN TERM:U/W 0.025 SQ PIN	80009	136-0263-04
-99	131-0156-00			2	..CONN,RF PLUG:	24931	32JR104-3
-100	334-3654-00			1	..PLATE,IDENT:MARKED PANELS/TAGS DIVESTMENT T ..O USING DIVISION CONTROL	80009	334-3654-00
-101	342-0474-00			20	..INSUL HALF,FEED:DELTRIN	80009	342-0474-00
-102	131-0593-00			10	..TERMINAL,PIN:	80009	131-0593-00
-103	407-2312-00			2	..BRACKET,SYNTHZR:PHASE LOCK,AL (ATTACHING PARTS)	80009	407-2312-00
-104	211-0007-01			4	..SCREW,MACHINE:4-40 X 0.188,PNH,STL (END ATTACHING PARTS)	26233	ORDER BY DESCR
-105	200-2243-00			1	..COV,PH LOCK SYN:REAR (ATTACHING PARTS)	80009	200-2243-00
-106	211-0087-01			8	..SCREW,MACHINE:2-56 X 0.188,FLH,82 DEG,STL (END ATTACHING PARTS)	TK0435	ORDER BY DESCR
-107	-----			1	..CKT BOARD ASSY:STROBE DRIVER (SEE A50A2 REPL) (ATTACHING PARTS)		
-108	211-0007-01			4	..SCREW,MACHINE:4-40 X 0.188,PNH,STL (END ATTACHING PARTS)	26233	ORDER BY DESCR
					..CKT BOARD ASSY INCLUDES:		
-109	214-4085-00			2	..TERM,TEST POINT:0.070 ID,0.220 H,0.063 DIA ..PCB,0.015 X 0.032 BRASS,W/ RED NYLON COLLAR	26364	104-01-02
-110	348-0737-00			1	..SHLD GSKT,ELEK:TAPE MESH,0.375 W	53217	23-90110
-111	-----			1	..FILTER,BANDPASS:(SEE A50A2FL1024 REPL) (ATTACHING PARTS)		

Replaceable Mechanical Parts
494A/494AP Service Vol.2

Fig. & Index No.	Tektronix Part No.	Serial/Assembly No. Effective Dscnt	Qty	12345 Name & Description	Mfr. Code	Mfr. Part No.
5-112	211-0007-01		2	..SCREW,MACHINE:4-40 X 0.188,PNH,STL ..(END ATTACHING PARTS)	26233	ORDER BY DESCR
-113	136-0263-04		4	..SOCKET,PIN TERM:U/W 0.025 SQ PIN	80009	136-0263-04
-114	131-0156-00		2	..CONN,RF PLUG:	24931	32JR104-3
-115	334-3652-00		1	..PLATE,IDENT:MARKED O LOCK SYNTH,REAR	80009	334-3652-00
-116	337-2680-03		1	..SHIELD,ELEC:PHASE LOCK SYNTHESIZER ..(ATTACHING PARTS)	80009	337-2680-03
-117	211-0196-00		2	..SCREW,MACHINE:4-40 X 0.188,SCH,STL ..(END ATTACHING PARTS)	TK0428	ORDER BY DESCR
-118	337-2566-01		1	..SHIELD,ELEC:PH LOCK SYNTHESIZER,FRONT	80009	337-2566-01
-119	-----		1	..CKT BOARD ASSY:ERROR AMP(SEE A50A4 REPL) ..(ATTACHING PARTS)		
-120	211-0007-01		3	..SCREW,MACHINE:4-40 X 0.188,PNH,STL ..(END ATTACHING PARTS)	26233	ORDER BY DESCR
-121	-----		1	..CKT BOARD ASSY INCLUDES: ..MICROCIRCUIT,L1:(SEE A50A4U2075 REPL) ..(ATTACHING PARTS)		
-122	211-0008-01		1	..SCREW,MACHINE:4-40 X 0.25,PNH,STL ..(END ATTACHING PARTS)	26233	ORDER BY DESCR
-123	131-2167-00		1	..CONN,BOX:	80009	131-2167-00
-124	131-2196-00		1	..CONN,BOX:	80009	131-2196-00
-125	214-4085-00		3	..TERM,TEST POINT:0.070 ID,0.220 H,0.063 DIA ..PCB,0.015 X 0.032 BRASS,W/ RED NYLON COLLAR	26364	104-01-02
-126	131-0993-00		2	..CONN,BOX:SHUNT/SHORTING,;FEMALE,STR,1 X 2,0 ..I CTR,0.385 H,30 GOLD,BLACK,JUMPER;	22526	65474-006
-127	131-0608-00		5	..TERMINAL,PIN:0.365 L X 0.025 BRZ GLD PL	80009	131-0608-00
-128	136-0263-04		12	..SOCKET,PIN TERM:U/W 0.025 SQ PIN	80009	136-0263-04
-129	386-4508-00		1	..PLATE,ELEC GND:0.63 X 0.5 X 2.1,AL/STL ALY ..CKT BOARD ASSY:COUNTER(SEE A51 REPL) ..(ATTACHING PARTS)	80009	386-4508-00
-130	211-0666-00		2	..SCREW,MACHINE:6-32 X 4.25,PNH,STL	83486	ORDER BY DESCR
-131	211-0507-00		1	..SCREW,MACHINE:6-32 X 0.312,PNH,STL ..(END ATTACHING PARTS)	83385	ORDER BY DESCR
-132	-----		1	..CKT BOARD ASSY INCLUDES: ..CKT BOARD ASSY:COUNTER(SEE A51A1 REPL) ..(ATTACHING PARTS)		
-133	211-0116-00		4	..SCR,ASSEM WSHR:4-40 X 0.312,PNH,BRS,NP,POZ ..(END ATTACHING PARTS)	77900	ORDER BY DESCR
-134	131-2167-00		2	..CONN,BOX:	80009	131-2167-00
-135	131-2196-00		1	..CONN,BOX:	80009	131-2196-00
-136	131-0993-00		2	..CONN,BOX:SHUNT/SHORTING,;FEMALE,STR,1 X 2,0 ..I CTR,0.385 H,30 GOLD,BLACK,JUMPER;	22526	65474-006
-137	131-0608-00		9	..TERMINAL,PIN:0.365 L X 0.025 BRZ GLD PL	80009	131-0608-00
-138	-----		2	..CONN,RCPT,ELEC:MINTR,CKT BD MTD,FEM,RTNG ..(A51A1P1036,A51A1P1056 REPL)		
-139	214-4085-00		8	..TERM,TEST POINT:0.070 ID,0.220 H,0.063 DIA ..PCB,0.015 X 0.032 BRASS,W/ RED NYLON COLLAR	26364	104-01-02
-140	346-0032-00		1	..STRAP,RETAINING:0.075 DIA X 4.0 L,MLD RBR	98159	2829-75-4
-141	131-0938-00		2	..CONN,RF JACK::SMB/PNL,;MALE,STR,50 OHM,0.25 ..HEX,2.0 L 0.025 DIA TAIL,10-32 THD,REAR MT	24931	32JR125-1
-142	352-0512-05		1	..HOLDER,CKT BD:ALUMINUM	80009	352-0512-05
-143	211-0666-00		2	..CKT BOARD ASSY INCLUDES: ..(ATTACHING PARTS)	83486	ORDER BY DESCR
-144	211-0507-00		1	..SCREW,MACHINE:6-32 X 4.25,PNH,STL ..SCREW,MACHINE:6-32 X 0.312,PNH,STL ..(END ATTACHING PARTS)	83385	ORDER BY DESCR
-145	-----		1	..CKT BOARD ASSY INCLUDES: ..CKT BOARD ASSY:AUX SYNTHESIZER ..(SEE A26A1 REPL) ..(ATTACHING PARTS)		
-146	211-0116-00		3	..SCR,ASSEM WSHR:4-40 X 0.312,PNH,BRS,NP,POZ	77900	ORDER BY DESCR
-147	211-0008-01		1	..SCREW,MACHINE:4-40 X 0.25,PNH,STL ..(END ATTACHING PARTS)	26233	ORDER BY DESCR
-148	214-4085-00		3	..CKT BOARD ASSY INCLUDES: ..TERM,TEST POINT:0.070 ID,0.220 H,0.063 DIA ..PCB,0.015 X 0.032 BRASS,W/ RED NYLON COLLAR	26364	104-01-02

Replaceable Mechanical Parts
494A/494AP Service Vol.2

Fig. & Index No.	Tektronix Part No.	Serial/Assembly No.		Qty	12345 Name & Description	Mfr.	
		Effective	Dscont			Code	Mfr. Part No.
5-149	131-2196-00			1	..CONN,BOX:	80009	131-2196-00
-150	131-2167-00			1	..CONN,BOX:	80009	131-2167-00
-151	131-0265-00			3	..CONN,RF PLUG::SMB,PCB,MALE,RTANG,50 OHM,0.3 ..81 H X 0.150 TAIL,0.043 DIA CTR COND,0.040 ..SQ TAIL	80009	131-0265-00
-152	337-3093-00			1	..SHIELD,ELEC:AUX SYN BD	80009	337-3093-00
-153	346-0032-00			1	..STRAP,RETAINING:0.075 DIA X 4.0 L,MLD RBR	98159	2829-75-4
-154	131-0372-00			1	..CONN,RF PLUG:	80009	131-0372-00
-155	210-0206-00			1	..TERMINAL,LUG:0.2 ID,LOCKING,BRZ TINNED	86828	A373-147-1
-156	352-0512-05			1	..HOLDER,CKT BD:ALUMINUM	80009	352-0512-05
-157	-----			1	CKT BOARD ASSY:MEMORY(SEE A54 REPL)		
	136-0755-00	B020701		7	..SOCKET,DIP:	09922	D1LB28P-108
-158	131-2196-00			1	..CONN,BOX:	80009	131-2196-00
-159	131-2167-00			2	..CONN,BOX:	80009	131-2167-00
-160	214-4085-00			1	..TERM,TEST POINT:0.070 ID,0.220 H,0.063 DIA ..PCB,0.015 X 0.032 BRASS,W/ RED NYLON COLLAR	26364	104-01-02
-161	346-0032-00			1	..STRAP,RETAINING:0.075 DIA X 4.0 L,MLD RBR	98159	2829-75-4
-162	174-0176-00			1	CA ASSY,SP,ELEC:3,26 AWG,3.0 L	TK1375	174-0176-00
-163	-----			1	CKT BOARD ASSY:GPIB(SEE A56 REPL)		
	136-0755-00	B020701		2	..SOCKET,DIP:	09922	D1LB28P-108
-164	131-2196-00			1	..CONN,BOX:	80009	131-2196-00
-165	131-3091-00			1	..CONN,BOX:	80009	131-3091-00
-166	131-2167-00			1	..CONN,BOX:	80009	131-2167-00
-167	131-0993-00			3	..CONN,BOX:SHUNT/SHORTING,;FEMALE,STR,1 X 2,0 ..1 CTR,0.385 H,30 GOLD,BLACK,JUMPER;	22526	65474-006
-168	346-0032-00			1	..STRAP,RETAINING:0.075 DIA X 4.0 L,MLD RBR	98159	2829-75-4
-169	131-0608-00			14	..TERMINAL,PIN:0.365 L X 0.025 BRZ GLD PL	80009	131-0608-00
-170	131-1425-00			1	..CONN,HDR:PCB,;MALE,RTANG,1 X 36,0.1 CTR,0.2 ..30 MLG X 0.090 TAIL,30 GOLD,STACKABLE;;	22526	65521-136
-171	-----			1	CKT BOARD ASSY:PROCESSOR(SEE A58 REPL)		
-172	131-0993-00			5	..CONN,BOX:SHUNT/SHORTING,;FEMALE,STR,1 X 2,0 ..1 CTR,0.385 H,30 GOLD,BLACK,JUMPER;	22526	65474-006
-173	131-0608-00			5	..TERMINAL,PIN:0.365 L X 0.025 BRZ GLD PL	80009	131-0608-00
-174	131-2196-00			1	..CONN,BOX:	80009	131-2196-00
-175	131-2167-00			2	..CONN,BOX:	80009	131-2167-00
-176	131-1425-00			1	..CONN,HDR:PCB,;MALE,RTANG,1 X 36,0.1 CTR,0.2 ..30 MLG X 0.090 TAIL,30 GOLD,STACKABLE;;	22526	65521-136
-177	-----			1	CKT BOARD ASSY:DIGITAL STORAGE INTFC (SEE A60 REPL)		
-178	131-2167-00			2	..CONN,BOX:	80009	131-2167-00
-179	131-2196-00			1	..CONN,BOX:	80009	131-2196-00
-180	131-0993-00			2	..CONN,BOX:SHUNT/SHORTING,;FEMALE,STR,1 X 2,0 ..1 CTR,0.385 H,30 GOLD,BLACK,JUMPER;	22526	65474-006
-181	131-0608-00			4	..TERMINAL,PIN:0.365 L X 0.025 BRZ GLD PL	80009	131-0608-00
-182	351-0580-00			3	..GUIDE,CKT BOARD:BLACK POLYPROPYLENE	80009	351-0580-00
	-----			1	CKT BOARD ASSY:DIGITAL STOR(SEE A61 REPL) (ATTACHING PARTS)		
-183	211-0666-00			2	SCREW,MACHINE:6-32 X 4.25,PNH,STL	83486	ORDER BY DESCR
-184	211-0507-00			1	SCREW,MACHINE:6-32 X 0.312,PNH,STL (END ATTACHING PARTS)	83385	ORDER BY DESCR
-185	-----			1	CKT BOARD ASSY INCLUDES: ..CKT BOARD ASSY:DIGITAL STORAGE (SEE A61A1 REPL) (ATTACHING PARTS)		
-186	211-0116-00			4	..SCR,ASSEM WSHR:4-40 X 0.312,PNH,BRS,NP,POZ (END ATTACHING PARTS)	77900	ORDER BY DESCR
-187	131-2167-00			2	..CONN,BOX:	80009	131-2167-00
-188	131-2196-00			1	..CONN,BOX:	80009	131-2196-00
-189	131-0993-00			2	..CONN,BOX:SHUNT/SHORTING,;FEMALE,STR,1 X 2,0 ..1 CTR,0.385 H,30 GOLD,BLACK,JUMPER;	22526	65474-006
-190	131-0608-00			4	..TERMINAL,PIN:0.365 L X 0.025 BRZ GLD PL	80009	131-0608-00
-191	352-0512-05			1	..HOLDER,CKT BD:ALUMINUM	80009	352-0512-05
-192	407-0517-00			1	BRACKET,CKT BD:ALUMINUM	80009	407-0517-00
-193	337-2803-00			1	SHIELD,ELEC:CIRCUIT BOARD (ATTACHING PARTS)	80009	337-2803-00
-194	211-0105-01			6	SCREW,MACHINE:4-40 X 0.188,FLH,100 DEG,STL, CD PL,POZ,W/NYLON PATCH	26233	ORDER BY DESCR

Replaceable Mechanical Parts
494A/494AP Service Vol.2

Fig. & Index No.	Tektronix Part No.	Serial/Assembly No. Effective Dscont	Qty	12345 Name & Description	Mfr. Code	Mfr. Part No.
5-	-----		1	(END ATTACHING PARTS) CKT BOARD ASSY:LOG AMP(SEE A62 REPL)		
-195	211-0666-00		2	(ATTACHING PARTS) SCREW,MACHINE:6-32 X 4.25,PNH,STL	83486	ORDER BY DESCR
-196	211-0507-00		1	SCREW,MACHINE:6-32 X 0.312,PNH,STL (END ATTACHING PARTS) CKT BOARD ASSY INCLUDES:	83385	ORDER BY DESCR
-197	-----		1	.CKT BOARD ASSY:LOG AMPLIFIER (SEE A62A1 REPL) (ATTACHING PARTS)		
-198	211-0116-00		4	.SCR,ASSEM WSHR:4-40 X 0.312,PNH,BRS,NP,POZ (END ATTACHING PARTS) .CKT BOARD ASSY INCLUDES:	77900	ORDER BY DESCR
-199	131-2167-00		1	..CONN,BOX:	80009	131-2167-00
-200	131-2196-00		1	..CONN,BOX:	80009	131-2196-00
-201	131-0608-00		6	..TERMINAL,PIN:0.365 L X 0.025 BRZ GLD PL	80009	131-0608-00
-202	214-4085-00		2	..TERM,TEST POINT:0.070 ID,0.220 H,0.063 DIA ..PCB,0.015 X 0.032 BRASS,W/ RED NYLON COLLAR	26364	104-01-02
-203	131-0372-00		2	.CONN,RF PLUG:	80009	131-0372-00
-204	131-0938-00		1	.CONN,RF JACK:;SMB/PNL,;MALE,STR,50 OHM,0.25 .HEX,2.0 L 0.025 DIA TAIL,10-32 THD,REAR MT	24931	32JRI25-1
-205	276-0554-00		2	.CORE,EM:TOROID,FERRITE	78488	57-1312
-206	352-0512-05		1	.HOLDER,CKT BD:ALUMINUM	80009	352-0512-05
-207	175-2623-00		1	.CA ASSY,SP,ELEC:2,26 AWG,3.0 L,RIBBON	TK1375	ORDER BY DESCR
	352-0169-00		1	..HLDR,TERM CONN:2 WIRE,BLACK	80009	352-0169-00
	175-4090-00		1	.CA ASSY,SP,ELEC:2,26 AWG,11.0 L,RIBBON	TK1375	175-4090-00
	352-0169-00		1	..HLDR,TERM CONN:2 WIRE,BLACK	80009	352-0169-00
	175-8736-00		1	.CA ASSY,SP,ELEC:2,26 AWG,6.0 L,RIBBON CKT BOARD ASSY:DEFL AMP(SEE A64 REPL) (ATTACHING PARTS)	TK1375	175-8736-00
-208	211-0666-00		2	SCREW,MACHINE:6-32 X 4.25,PNH,STL	83486	ORDER BY DESCR
-209	211-0507-00		1	SCREW,MACHINE:6-32 X 0.312,PNH,STL (END ATTACHING PARTS) CKT BOARD ASSY INCLUDES:	83385	ORDER BY DESCR
-210	200-2238-01		1	.COVER,CKT BOARD:DEFLECTION AMP	80009	200-2238-01
-211	334-2257-01		1	.MARKER,IDENT:MARKED CAUTION	80009	334-2257-01
-212	337-3143-00		1	.SHIELD,ELEC:DEFLECTION AMP	80009	337-3143-00
-213	214-2867-02		2	.HEAT SINK,XSTR:(2)TO-202,AL (ATTACHING PARTS)	80009	214-2867-02
-214	211-0001-00		4	.SCREW,MACHINE:2-56 X 0.25,PNH,STL	93907	ORDER BY DESCR
-215	210-0850-00		4	.WASHER,FLAT:0.093 ID X 0.281 OD X 0.02,STL	12327	ORDER BY DESCR
-216	211-0019-00		2	.SCREW,MACHINE:4-40 X 1.0,PNH,STL	93907	ORDER BY DESCR
-217	210-1171-00		2	.WASHER,SHLDR:0.12 ID X 0.143 OD X 0.07 D	00261	A7148516P2
-218	210-0921-00		2	.INSULATOR,WSHR:0.141 ID X 0.5 OD	08530	RM493X010MC
-219	361-0582-00		2	.SPACER,SLEEVE:0.7 L X 0.134 ID,ALUMINUM (END ATTACHING PARTS)	80009	361-0582-00
-220	-----		1	.CKT BOARD ASSY:DEFLECTION AMP (SEE A64A1 REPL) (ATTACHING PARTS)		
-221	211-0116-00		4	.SCR,ASSEM WSHR:4-40 X 0.312,PNH,BRS,NP,POZ (END ATTACHING PARTS) .CKT BOARD ASSY INCLUDES:	77900	ORDER BY DESCR
-222	131-0993-00		4	..CONN,BOX:SHUNT/SHORTING,;FEMALE,STR,1 X 2,0 ...1 CTR,0.385 H,30 GOLD,BLACK,JUMPER;	22526	65474-006
-223	131-0608-00		14	..TERMINAL,PIN:0.365 L X 0.025 BRZ GLD PL	80009	131-0608-00
-224	131-2196-00		1	..CONN,BOX:	80009	131-2196-00
-225	131-2167-00		2	..CONN,BOX:	80009	131-2167-00
-226	214-4085-00		1	..TERM,TEST POINT:0.070 ID,0.220 H,0.063 DIA ..PCB,0.015 X 0.032 BRASS,W/ RED NYLON COLLAR	26364	104-01-02
-227	352-0512-05		1	.HOLDER,CKT BD:ALUMINUM	80009	352-0512-05
-228	211-0666-00		2	CKT BOARD ASSY:CRT READOUT(SEE A66 REPL) (ATTACHING PARTS)		
-229	211-0507-00		1	SCREW,MACHINE:6-32 X 4.25,PNH,STL	83486	ORDER BY DESCR
			1	SCREW,MACHINE:6-32 X 0.312,PNH,STL (END ATTACHING PARTS) CKT BOARD ASSY INCLUDES:	83385	ORDER BY DESCR
-230	-----		1	.CKT BOARD ASSY:CRT READOUT(SEE A66A1REPL) (ATTACHING PARTS)		

Replaceable Mechanical Parts
494A/494AP Service Vol.2

Fig. & Index No.	Tektronix Part No.	Serial/Assembly No.		Qty	12345 Name & Description	Mfr.	
		Effective	Discont			Code	Mfr. Part No.
5-231	211-0116-00			4	.SCR,ASSEM WSHR:4-40 X 0.312,PNH,BRS,NP,POZ (END ATTACHING PARTS)	77900	ORDER BY DESCR
-232	214-4085-00			3	.CKT BOARD ASSY INCLUDES: ..TERM,TEST POINT:0.070 ID,0.220 H,0.063 DIA ..PCB,0.015 X 0.032 BRASS,W/ RED NYLON COLLAR	26364	104-01-02
-233	131-2196-00			1	..CONN,BOX:	80009	131-2196-00
-234	131-2167-00			2	..CONN,BOX:	80009	131-2167-00
-235	346-0032-00			1	..STRAP,RETAINING:0.075 DIA X 4.0 L,MLD RBR	98159	2829-75-4
-236	352-0512-05			1	.HOLDER,CKT BD:ALUMINUM	80009	352-0512-05

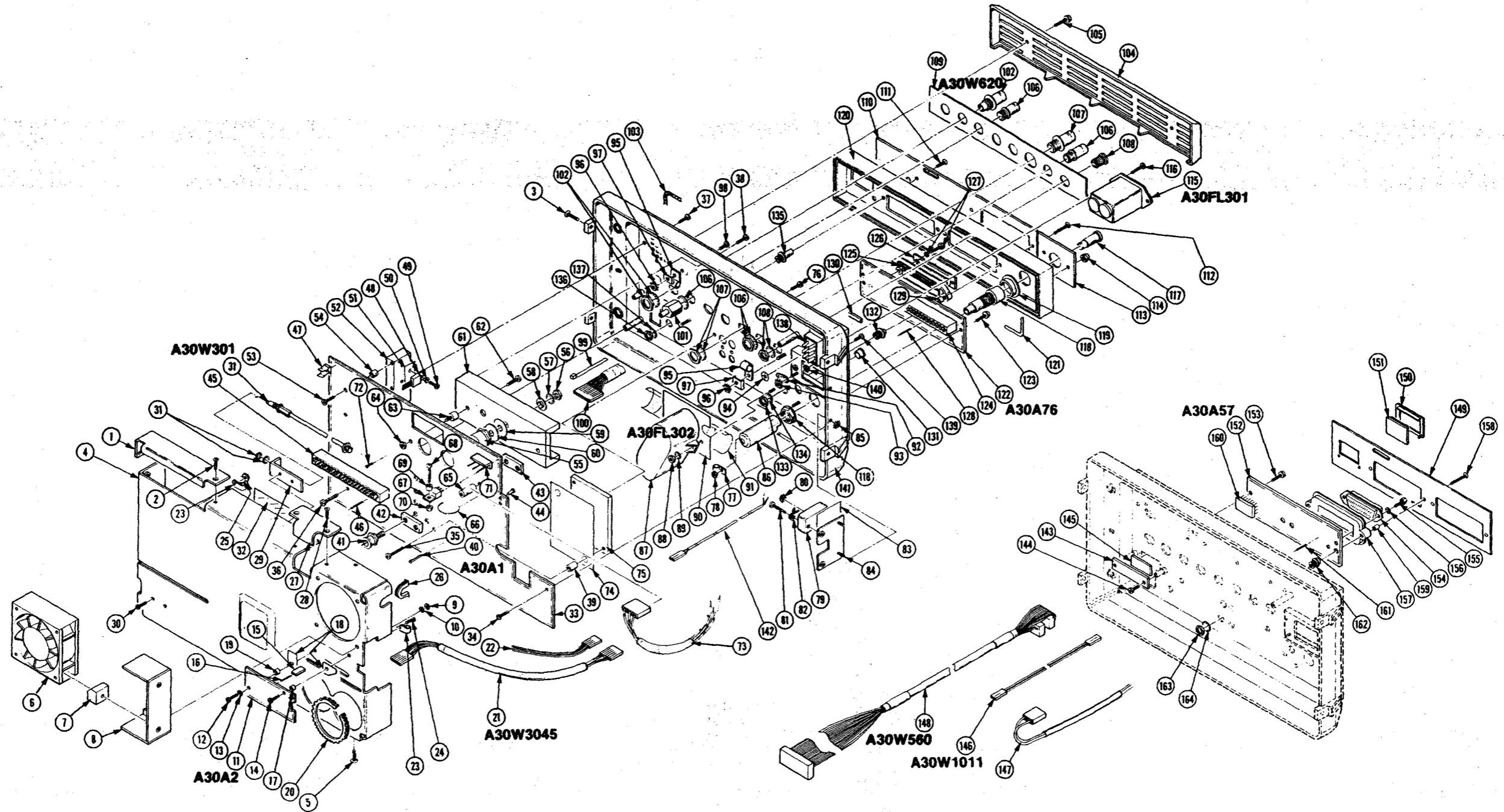

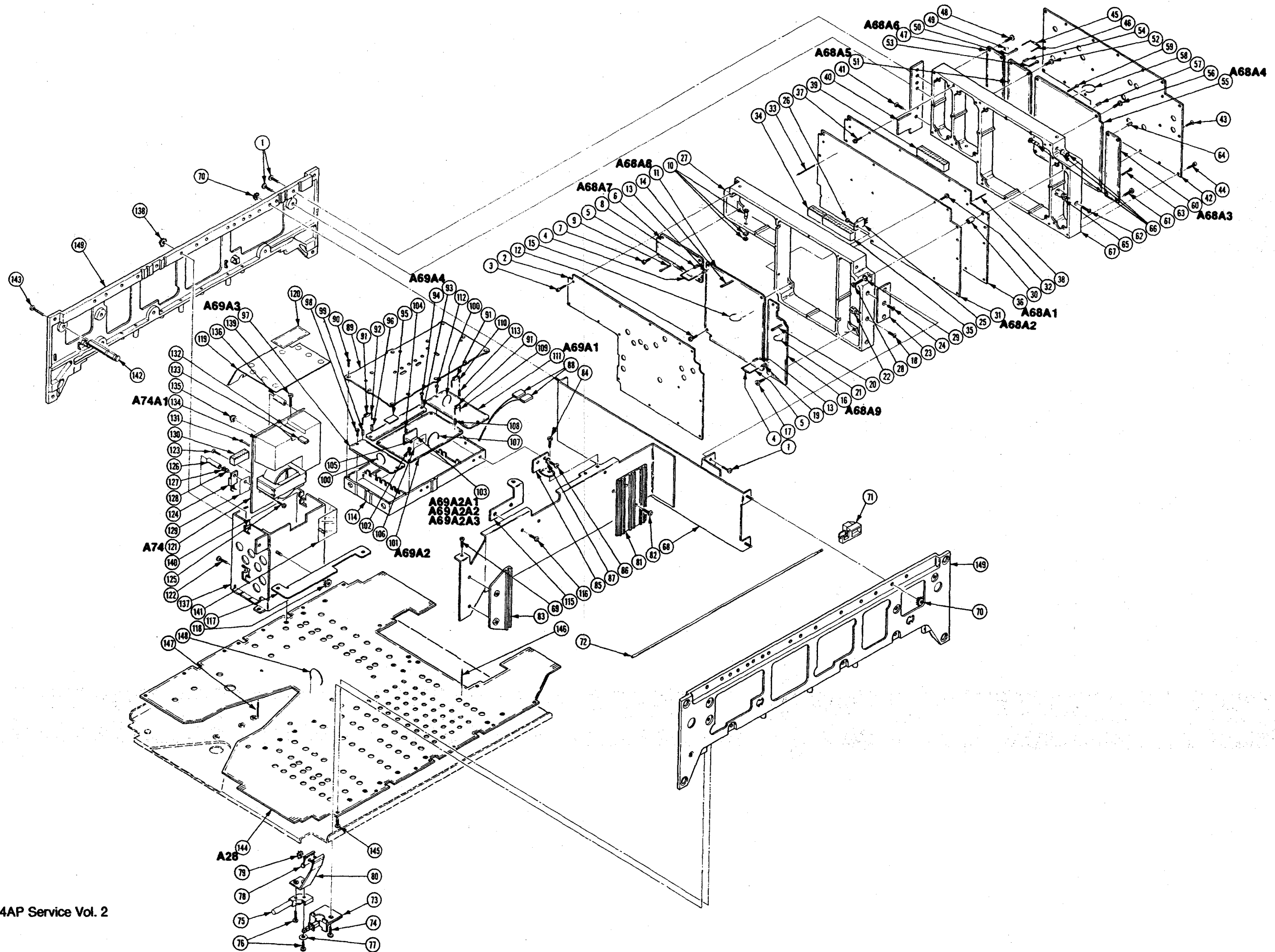

Replaceable Mechanical Parts
494A/494AP Service Vol.2

Fig. & Index No.	Tektronix Part No.	Serial/Assembly No.		Qty	12345 Name & Description	Mfr.	
		Effective	Discort			Code	Mfr. Part No.
2-1	426-1523-05			1	FRAME, MASK: 5.0 CRT, SILVER GRAY, PLASTIC	80009	426-1523-05
-2	378-0115-00			1	FILTER, LT, CRT: BLUE, 4.176 X 3.418, PLASTIC	80009	378-0115-00
-3	-----			1	CKT BOARD ASSY: CRT GRATICULE LIGHT (SEE A77 REPL) (ATTACHING PARTS)		
-4	213-0772-00			2	SCREW, TPG, TF: 2-28 X 0.5, PLASTITE, PNH, STL (END ATTACHING PARTS)	83486	ORDER BY DESCR
-5	-----			2	CKT BOARD ASSY INCLUDES: .CONTACT, ELEC: 0.885 INCH LONG (SEE A77P770 REPL)		
-6	200-2216-01			1	RTNR, CRT SCALE: 5.0 CRT, ALUMINUM (ATTACHING PARTS)	80009	200-2216-01
-7	212-0128-00			4	SCREW, CAP: 8-32 X 0.5, SCH, STL (END ATTACHING PARTS)	TK0433	ORDER BY DESCR
-8	378-0877-00	B010100	B020593	1	REFLECTOR, LIGHT: PLASTIC	80009	378-0877-00
	378-0877-02	B020594		1	REFLECTOR, LIGHT: PLASTIC	80009	378-0877-02
-9	337-2577-00			1	SHLD, IMPLSION: CLEAR, 5.0 CRT, PLASTIC	80009	337-2577-00
-10	366-1786-01			4	SHELL, KNOB: GRAY, 0.375 OD X 0.55 H,	80009	366-1786-01
	213-0193-00			4	.SETSCREW: 4-40 X 0.094, STL	80009	213-0193-00
-11	210-1160-00			2	WASHER, FLAT: 0.129 ID X 0.25 OD X 0.031	86928	5612-32-31
-12	366-1781-00			1	SHELL, KNOB: SIL GY, 0.587 OD X 0.625 H	80009	366-1781-00
-13	358-0301-01			2	BUSHING, SLEEVE: 0.16 ID X 0.205 OD	80009	358-0301-01
-14	-----			2	TERMN, COAXIAL: (SEE P800, P900 REPL) (ATTACHING PARTS)		
-15	220-0531-02			2	NUT, PLAIN, HEX: 0.25-36 X 0.312 HEX, BRS NP	80009	220-0531-02
	210-0940-00			2	WASHER, FLAT: 0.25 ID X 0.375 OD X 0.02, STL (END ATTACHING PARTS)	12327	ORDER BY DESCR
-16	366-1782-01			1	SHELL, KNOB: SIL GRAY, 1.125 OD X 0.65 H, ABS	80009	366-1782-01
-17	366-1780-01			2	SHELL, KNOB: SIL GRAY, 1.375 OD X 0.375 H	80009	366-1780-01
-18	366-1779-01			1	SHELL, KNOB: SIL GY, 1.1 OD X 0.5 H, PLSTC	80009	366-1779-01
-19	366-1779-00			1	SHELL, KNOB: SIL GY, 1.1 OD X 0.5 H, PLSTC	80009	366-1779-00
-20	358-0301-02			2	BUSHING, SLEEVE: 0.16 ID X 0.205 OD	80009	358-0301-02
-21	358-0216-00			1	GROMMET, PLASTIC: GRAY, ROUND, 0.257 ID	80009	358-0216-00
-22	333-3285-00			1	PANEL, FRONT: (494A ONLY)	80009	333-3285-00
	333-3373-00			1	PANEL, FRONT: (494A OPTION 07 ONLY)	80009	333-3373-00
	333-3374-00			1	PANEL, FRONT: (494A OPTION 08 ONLY)	80009	333-3374-00
	333-3286-00			1	PANEL, FRONT: (494AP ONLY)	80009	333-3286-00
	333-3375-00			1	PANEL, FRONT: (494AP OPTION 07 ONLY)	80009	333-3375-00
	333-3376-00			1	PANEL, FRONT: (494AP OPTION 08 ONLY)	80009	333-3376-00
	333-3473-00			1	PANEL, FRONT: (494AP OPTION 45 ONLY) (ATTACHING PARTS)	TK2065	333-3473-00
-23	211-0087-01			1	SCREW, MACHINE: 2-56 X 0.188, FLH, 82 DEG, STL (END ATTACHING PARTS)	TK0435	ORDER BY DESCR
-24	-----			1	CKT BOARD ASSY: FRONT PANEL (SEE A38 REPL) (ATTACHING PARTS)		
-25	211-0121-00			11	SCR, ASSEM WSHR: 4-40 X 0.438, PNH, BRS	93907	ORDER BY DESCR
-26	211-0008-01			1	SCREW, MACHINE: 4-40 X 0.25, PNH, STL	26233	ORDER BY DESCR
-27	210-1178-00			1	WASHER, SHLDR:	80009	210-1178-00
-28	342-0163-00			1	INSULATOR, PLATE: TRANSISTOR, MICA	80009	342-0163-00
-29	210-0851-00			1	WASHER, FLAT: 0.119 ID X 0.375 OD X 0.025, STL (END ATTACHING PARTS)	12327	ORDER BY DESCR
					CKT BOARD ASSY INCLUDES:		
-30	131-1229-00			1	.CONN, RCPT, ELEC: EDGE CARD, 22/44 CONT, 0.156 SP	05574	000201-5447
-31	214-1127-00			4	.ROLLER, DETENT: 0.125 DIA X 0.125, SST	80009	214-1127-00
-32	214-1126-01			4	.SPRING, FLAT: 0.7 X 0.125, CU BE GRN CLR	80009	214-1126-01
-33	210-0405-00			3	.NUT, PLAIN, HEX: 2-56 X 0.188, BRS CD PL	73743	12157-50
-34	210-0053-00			3	.WASHER, LOCK: #2 SPLIT, 0.02 THK STL	78189	ORDER BY DESCR
-35	401-0340-01			2	.BEARING, RTRY SW: FRONT, 0.375 DIA	80009	401-0340-01
-36	384-1462-07			1	.SHAFT, ROTARY SW: W/DETENT, 18/7 POSN, 20 DEG	80009	384-1462-07
-37	352-0457-25			1	.HOLDER, CONTACT: 1 CONTACT, GRAY PC	80009	352-0457-25
-38	352-0457-21			1	.HOLDER, CONTACT: PANCAKE SW, 4 CONT, GRAY PC	80009	352-0457-21

Replaceable Mechanical Parts
494A/494AP Service Vol.2

Fig. & Index No.	Tektronix Part No.	Serial/Assembly No.		Qty	12345	Name & Description	Mfr. Code	Mfr. Part No.
		Effective	Dscont					
2-39	384-1463-04			1		.SHAFT,ROTARY SW:16/11 POS,1.535 L	80009	384-1463-04
-40	211-0034-00			3		.SCREW,MACHINE:2-56 X 0.5,PNH,STL	06950	ORDER BY DESCR
-41	214-1126-01			4		.SPRING,FLAT:0.7 X 0.125,CU BE GRN CLR	80009	214-1126-01
-42	214-1127-00			4		.ROLLER,DETENT:0.125 DIA X 0.125,SST	80009	214-1127-00
-43	210-0405-00			3		.NUT,PLAIN,HEX:2-56 X 0.188,BRS CD PL	73743	12157-50
-44	210-0053-00			3		.WASHER,LOCK:#2 SPLIT,0.02 THK STL	78189	ORDER BY DESCR
-45	401-0340-01			2		.BEARING,RTRY SW:FRONT,0.375 DIA	80009	401-0340-01
-46	384-1462-06			1		.SHAFT,ROTARY SW:W/DETENT,24 POSN,15 DEG	80009	384-1462-06
-47	352-0457-21			2		.HOLDER,CONTACT:PANCAKE SW,4 CONT,GRAY PC	80009	352-0457-21
-48	384-1463-04			3		.SHAFT,ROTARY SW:16/11 POS,1.535 L	80009	384-1463-04
-49	211-0034-00			1		.SCREW,MACHINE:2-56 X 0.5,PNH,STL	06950	ORDER BY DESCR
-50	-----			1		.RESISTOR,VAR:(SEE A38R6049 REPL) .(ATTACHING PARTS)		
-51	210-0583-00			1		.NUT,PLAIN,HEX:0.25-32 X 0.312,BRS CD PL	73743	2X-20319-402
-52	210-0046-00			1		.WASHER,LOCK:0.261 ID,INTL,0.018 THK,STL	77900	1214-05-00-0541C
-53	210-0940-00			1		.WASHER,FLAT:0.25 ID X 0.375 OD X 0.02,STL .(END ATTACHING PARTS)	12327	ORDER BY DESCR
-54	-----			1		.RESISTOR,VAR:(SEE A38R6051 REPL) .(ATTACHING PARTS)		
-55	210-0583-00			1		.NUT,PLAIN,HEX:0.25-32 X 0.312,BRS CD PL	73743	2X-20319-402
-56	210-0046-00			1		.WASHER,LOCK:0.261 ID,INTL,0.018 THK,STL	77900	1214-05-00-0541C
-57	210-0940-00			1		.WASHER,FLAT:0.25 ID X 0.375 OD X 0.02,STL .(END ATTACHING PARTS)	12327	ORDER BY DESCR
-58	-----			1		.RESISTOR,VAR:(SEE A38R6062 REPL) .(ATTACHING PARTS)		
-59	210-0583-00			1		.NUT,PLAIN,HEX:0.25-32 X 0.312,BRS CD PL	73743	2X-20319-402
-60	210-0046-00			1		.WASHER,LOCK:0.261 ID,INTL,0.018 THK,STL	77900	1214-05-00-0541C
-61	210-0940-00			1		.WASHER,FLAT:0.25 ID X 0.375 OD X 0.02,STL .(END ATTACHING PARTS)	12327	ORDER BY DESCR
-62	214-1126-01			1		.SWITCH,ROTARY:(SEE A38S2035 REPL)		
-63	214-3197-00			1		.SPRING,FLAT:0.7 X 0.125,CU BE GRN CLR	80009	214-1126-01
-64	210-0406-00			3		.BUTTON,FRICITION:ACETAL NATURAL	80009	214-3197-00
-65	210-1002-00			3		.NUT,PLAIN,HEX:4-40 X 0.188,BRS CD PL	73743	12161-50
-66	211-0016-00			3		.WASHER,FLAT:0.125 ID X 0.25 OD X 0.022,BRS	86928	5714-147-20N
-67	210-0004-00			3		.SCREW,MACHINE:4-40 X 0.625,PNH,STL	TK0435	ORDER BY DESCR
-68	343-0703-00			3		.WASHER,LOCK:#4 INTL,0.015 THK,STL	77900	1204-00-00-0541C
-69	380-0504-00			1		.RETAINER,PXSTR:ACETAL,GRAY	TK1319	N/A
-70	384-1522-01			1		.HOUSING,SWITCH:POLYCARBONATE	TK1319	N/A
-71	210-0992-00			1		.SHAFT,ROTARY SW:1.374 L X 0.248 OD,BRASS	80009	384-1522-01
-72	351-0528-00			1		.WASHER,FLAT:0.265 ID X 0.437 OD X 0.01	80009	210-0992-00
-73	401-0418-00			1		.GUIDE,LIGHT:CLEAR POLYCARBONATE	TK1319	N/A
-74	131-0590-00			1		.BEARING,RTRY SW:FRONT,0.254 ID	80009	401-0418-00
-75	-----			4		.TERMINAL,PIN:0.71 L X 0.025 SQ PH BRZ	80009	131-0590-00
-76	-----			2		.TERMINAL,PIN:0.46 L X 0.025 SQ .(SEE A38P5090 REPL) .RESISTOR,VAR:(SEE A38R6104, .A38R6106 REPL) .(ATTACHING PARTS)		
-77	210-0583-00			2		.NUT,PLAIN,HEX:0.25-32 X 0.312,BRS CD PL	73743	2X-20319-402
-78	210-0046-00			2		.WASHER,LOCK:0.261 ID,INTL,0.018 THK,STL	77900	1214-05-00-0541C
-79	210-0940-00			2		.WASHER,FLAT:0.25 ID X 0.375 OD X 0.02,STL .(END ATTACHING PARTS)	12327	ORDER BY DESCR
-80	214-1126-01			1		.SPRING,FLAT:0.7 X 0.125,CU BE GRN CLR	80009	214-1126-01
-81	214-1127-00			1		.ROLLER,DETENT:0.125 DIA X 0.125,SST	80009	214-1127-00
-82	213-0759-00			3		.SCREW,TPG,TF:2-28 X 0.437,PNH,STL	93907	ORDER BY DESCR
-83	401-0340-01			1		.BEARING,RTRY SW:FRONT,0.375 DIA	80009	401-0340-01
-84	384-1462-06			1		.SHAFT,ROTARY SW:W/DETENT,24 POSN,15 DEG	80009	384-1462-06
-85	352-0457-22			1		.HOLDER,CONTACT:PANCAKE SW,2 CONT,GRAY PC	80009	352-0457-22
-86	401-0341-01			1		.BEARING,RTRY SW:REAR,0.252 ID	80009	401-0341-01
-87	346-0032-00			1		.STRAP,RETAINING:0.075 DIA X 4.0 L,MLD RBR	98159	2829-75-4
-88	-----			3		.RESISTOR:(SEE A38R1121,A38R4043, .A38R4121 REPL) .(ATTACHING PARTS)		
-89	210-0583-00			3		.NUT,PLAIN,HEX:0.25-32 X 0.312,BRS CD PL	73743	2X-20319-402
-90	210-0046-00			3		.WASHER,LOCK:0.261 ID,INTL,0.018 THK,STL	77900	1214-05-00-0541C
-91	210-0940-00			3		.WASHER,FLAT:0.25 ID X 0.375 OD X 0.02,STL .(END ATTACHING PARTS)	12327	ORDER BY DESCR
-92	354-0392-00			9		.RING,RETAINING:EXT GRIP,U/O 0.125 DIA SFT	79136	5555-12ZD

Replaceable Mechanical Parts
494A/494AP Service Vol.2

Fig. & Index No.	Tektronix Part No.	Serial/Assembly No.		Qty	12345 Name & Description	Mfr.	
		Effective	Discont			Code	Mfr. Part No.
2-93	354-0177-00			3	RING,RETAINING:BASIC EXT,U/O 0.25 ID SHAFT	79136	5100-25-ZD
-94	214-2616-00			9	CONTACT,ELEC:GROUNDING,CU BE	80009	214-2616-00
-95	214-2617-00			3	SPRING,GROUND:0.248 ID,COPPER BERYLLIUM	80009	214-2617-00
-96	386-3969-00			1	PLATE,CONN MTG:ANTI ROTATION,ALUMINUM (ATTACHING PARTS)	80009	386-3969-00
-97	210-0589-00			1	NUT,SLFLKG,HEX:4-40 X 0.246,STL CD PL (END ATTACHING PARTS)	TK0409	CF22NM40
-98	131-2343-00			2	CONN,JACK,RF::	80009	131-2343-00
-99	-----			1	CABLE ASSY,RF:50 OHM COAX,17.52 L (SEE W340 REPL)		
	131-0818-00			1	.CONN,RF JACK:	91836	KC-19-153
-100	210-0201-00			1	TERMINAL,LUG:0.12 ID,LOCKING,BRZ TIN PL (ATTACHING PARTS)	86928	A373-157-2
-101	210-0586-00			1	NUT,PL,ASSEM WA:4-40 X 0.25,STL CD PL (END ATTACHING PARTS)	78189	211-041800-00
-102	343-0760-00			4	CLP,ELCTRN TUBE:CRT,POLYPHENYLENE (ATTACHING PARTS)	80009	343-0760-00
-103	211-0576-00			4	SCREW,CAP:6-32 X 0.875,SCH,STL (END ATTACHING PARTS)	56878	ORDER BY DESCR
-104	204-0820-00			1	BODY,TERMINAL:5.0 L CRT,PLASTIC	80009	204-0820-00
-105	337-0925-04	B010100	B020960	1	SHLD GSKT,ELEK:37.0 L	TK1375	ORDER BY DESCR
	337-0925-02	B020961		1	SHLD GSKT,ELEK:BULK	53217	21-00352
-106	386-3845-08			1	SUBPANEL,FRONT: (ATTACHING PARTS)	80009	386-3845-08
-107	212-0650-00			4	SCREW,MACHINE:10-32 X 0.437,FLH,100 DEG,SST (END ATTACHING PARTS)	83486	ORDER BY DESCR
-108	175-4641-00			1	CA ASSY,SP,ELEC:2,26 AWG,3.0 L,RIBBON	TK1375	175-4641-00
-109	343-0811-02			2	CLAMP,CRT:ABS (ATTACHING PARTS)	80009	343-0811-02
-110	211-0020-00			2	SCREW,MACHINE:4-40 X 1.125,PNH,STL	TK0435	ORDER BY DESCR
-111	210-0586-00			2	NUT,PL,ASSEM WA:4-40 X 0.25,STL CD PL (END ATTACHING PARTS)	78189	211-041800-00
-112	361-0920-00			2	SPACER,CRT SHLD: (ATTACHING PARTS)	80009	361-0920-00
-113	211-0116-00			2	SCR,ASSEM WSHR:4-40 X 0.312,PNH,BRS,NP,POZ	77900	ORDER BY DESCR
-114	213-0034-00			2	SCREW,TPG,TC:4-40 X 0.312,TYPE T,PNH,STL (END ATTACHING PARTS)	77250	ORDER BY DESCR
-115	334-3689-00			1	MARKER,IDENT:MKD J770	80009	334-3689-00
-116	348-0003-00			1	GROMMET,RUBBER:BLACK,ROUND,0.219 ID	70485	1411B6040
-117	210-0201-00			1	TERMINAL,LUG:0.12 ID,LOCKING,BRZ TIN PL (ATTACHING PARTS)	86928	A373-157-2
-118	210-0586-00			1	NUT,PL,ASSEM WA:4-40 X 0.25,STL CD PL	78189	211-041800-00
-119	211-0008-00			1	SCREW,MACHINE:4-40 X 0.25,PNH,STL (END ATTACHING PARTS)	93907	ORDER BY DESCR
-120	337-2623-00			1	SHIELD,CRT:FRONT (ATTACHING PARTS)	80009	337-2623-00
-121	210-0586-00			6	NUT,PL,ASSEM WA:4-40 X 0.25,STL CD PL (END ATTACHING PARTS)	78189	211-041800-00
-122	136-0717-00			1	SKT,PL-IN ELEK:ELCTRN TUBE,W/LEADS	TK1375	136-0717-00
-123	386-4165-00			3	PLATE,MOUNTING:CRT,ALUMINUM	80009	386-4165-00
-124	361-0921-00			1	SPACER,CRT SHLD:	80009	361-0921-00
-125	252-0571-00			AR	NEOPRENE EXTR:CHAN,0.234 X 0.156	85471	ORDER BY DESCR
-126	337-2622-00			1	SHIELD,CRT:REAR	80009	337-2622-00

Replaceable Mechanical Parts
494A/494AP Service Vol.2

Fig. & Index No.	Tektronix Part No.	Serial/Assembly No. Effective	Discont	Qty	12345 Name & Description	Mfr. Code	Mfr. Part No.
3-1	200-2221-00			1	COVER, ACCESS: REAR PANEL CONNECTORS, BOT (ATTACHING PARTS)	80009	200-2221-00
-2	211-0105-00			2	SCREW, MACHINE: 4-40 X 0.188, FLH, 100 DEG (END ATTACHING PARTS)	TK0435	ORDER BY DESCR
	-----			1	POWER SUPPLY: (SEE A30 REPL) (ATTACHING PARTS)		
-3	212-0650-00			4	SCREW, MACHINE: 10-32 X 0.437, FLH, 100 DEG, SST (END ATTACHING PARTS)	83486	ORDER BY DESCR
					POWER SUPPLY INCLUDES:		
-4	337-3368-00	B010100	B020692	1	.SHIELD, ELEC: POWER SUPPLY	80009	337-3368-00
	337-3368-01	B020693		1	.SHIELD, ELEC: POWER SUPPLY W/CUSHION (ATTACHING PARTS)	80009	337-3368-01
-5	211-0101-00			6	.SCREW, MACHINE: 4-40 X 0.25, FLH, 100 DEG, STL (END ATTACHING PARTS)	93907	ORDER BY DESCR
-6	-----			1	.FAN, TUBE AXIAL: (SEE A30B100 REPL) (ATTACHING PARTS)		
-7	426-1920-00			4	.MOUNT, RESILIENT: FAN, SILICONE RUBBER (END ATTACHING PARTS)	80009	426-1920-00
-8	407-2927-00			2	.BRACKET, CMPNT: FAN, ALUMINUM (ATTACHING PARTS)	80009	407-2927-00
-9	210-0406-00			4	.NUT, PLAIN, HEX: 4-40 X 0.188, BRS CD PL	73743	12161-50
-10	210-0054-00			4	.WASHER, LOCK: #4 SPLIT, 0.025 THK STL (END ATTACHING PARTS)	78189	ORDER BY DESCR
-11	-----			1	.CKT BOARD ASSY: FAN DRIVE (SEE A30A2 REPL) (ATTACHING PARTS)		
-12	211-0198-00			1	.SCREW, MACHINE: 4-40 X 0.438, PNH, STL	TK0435	ORDER BY DESCR
-13	210-1133-00			1	.WASHER, FLAT: 0.142 ID X 0.25 OD X 0.058, FBR	86928	ORDER BY DESCR
-14	211-0012-01			1	.SCREW, MACHINE: 4-40 X 0.375, PNH, STL (END ATTACHING PARTS)	26233	ORDER BY DESCR
					.CKT BOARD ASSY INCLUDES:		
-15	131-0993-00			1	.CONN, BOX: SHUNT/SHORTING, ; FEMALE, STR, 1 X 2, 0 ... 1 CTR, 0.385 H, 30 GOLD, BLACK, JUMPER;	22526	65474-006
-16	131-0608-00			16	.TERMINAL, PIN: 0.365 L X 0.025 BRZ GLD PL	80009	131-0608-00
-17	361-0994-00			1	.SPACER, SLEEVE: 0.195 L X 0.116 ID, RYTON-R-4	80009	361-0994-00
-18	342-0354-00			2	.INSULATOR, PLATE: TRANSISTOR	55285	7403-09FR-52
-19	361-0552-00			1	.SPACER, SLEEVE: 0.093 L X 0.126 ID, BRS	76854	3-5116-312
-20	255-0334-00			1	.PLASTIC CHANNEL: 12.75 X 0.175 X 0.155, NYLON	11897	122-37-2500
-21	-----			1	.CA ASSY, SP, ELEC: 5, 26 AWG, 18.0 L, RIBBON (SEE A30W3045 REPL)		
	352-0164-03			1	.HLDR, TERM CONN: 6 WIRE, ORANGE	80009	352-0164-03
	352-0164-06			1	.HLDR, TERM CONN: 6 WIRE, BLUE	80009	352-0164-06
-22	175-3159-00			1	.CA ASSY, SP, ELEC: 4, 26 AWG, 6.0 L, RIBBON	TK1375	175-3159-00
	352-0164-04			1	.HLDR, TERM CONN: 6 WIRE, YELLOW	80009	352-0164-04
-23	343-0144-00			3	.CLAMP, LOOP: 0.125 ID, NYLON (ATTACHING PARTS)	TK1452	ORDER BY DESCR
-24	211-0008-01			1	.SCREW, MACHINE: 4-40 X 0.25, PNH, STL	26233	ORDER BY DESCR
-25	210-0586-00			2	.NUT, PL, ASSEM WA: 4-40 X 0.25, STL CD PL (END ATTACHING PARTS)	78189	211-041800-00
-26	348-0115-00			1	.GROMMET, PLASTIC: BLACK, U-SHAPE, 0.368 ID	80009	348-0115-00
-27	200-2995-00			1	.COVER, ACCESS: LINE VOLTAGE (ATTACHING PARTS)	80009	200-2995-00
-28	211-0105-01			2	.SCREW, MACHINE: 4-40 X 0.188, FLH, 100 DEG, STL, . CD PL, POZ, W/NYLON PATCH (END ATTACHING PARTS)	26233	ORDER BY DESCR
-29	407-3036-00			1	.BRACKET, ANGLE: ALUMINUM (ATTACHING PARTS)	80009	407-3036-00
-30	211-0008-01			2	.SCREW, MACHINE: 4-40 X 0.25, PNH, STL (END ATTACHING PARTS)	26233	ORDER BY DESCR
-31	-----			1	.CABLE ASSY, RF: 50 OHM COAX, 6.10L (SEE A30W301 REPL)		
-32	342-0466-01			1	.INSULATOR, FILM: SHIELD, POLYESTER	80009	342-0466-01
-33	-----			1	.CKT BOARD ASSY: POWER SUPPLY (SEE A30A1 REPL) (ATTACHING PARTS)		
-34	211-0510-00			3	.SCREW, MACHINE: 6-32 X 0.375, PNH, STL	83385	ORDER BY DESCR
-35	211-0014-00			2	.SCREW, MACHINE: 4-40 X 0.5, PNH, STL	93907	ORDER BY DESCR
-36	211-0514-00			2	.SCREW, MACHINE: 6-32 X 0.750, PNH, STL	93907	820-70350
-37	211-0012-01			2	.SCREW, MACHINE: 4-40 X 0.375, PNH, STL	26233	ORDER BY DESCR

Replaceable Mechanical Parts
494A/494AP Service Vol.2

Fig. & Index No.	Tektronix Part No.	Serial/Assembly No.		Qty	12345 Name & Description	Mfr.	
		Effective	Dscont			Code	Mfr. Part No.
3-38	211-0097-01			6	..SCREW,MACHINE:4-40 X 0.312,PNH,STL	26233	ORDER BY DESCR
-39	361-0917-00			2	..SPACER,SLEEVE:0.25 L X 0.141 ID,ALUMINUM ..(END ATTACHING PARTS) ..CKT BOARD ASSY INCLUDES:	80009	361-0917-00
-40	214-4085-00			3	..TERM,TEST POINT:0.070 ID,0.220 H,0.063 DIA	26364	104-01-02
-41	-----			6	..PCB,0.015 X 0.032 BRASS,W/ RED NYLON COLLAR ..DIODES:(SEE A30A1CR4053,A30A1CR4057, ..A30A1CR5052,A30A1CR5055,A30A1CR5062, ..A30A1CR5065 REPL) ..(ATTACHING PARTS)		
-42	361-0933-00			3	..SPACER,DIODE:0.188 X 0.375 X 0.95,AL	80009	361-0933-00
-43	214-2770-00			3	..HEAT SINK,DIODE:(2)DO-4,ALUMINUM ..(END ATTACHING PARTS)	80009	214-2770-00
-44	136-0388-00			2	..SOCKET,PIN TERM:	80009	136-0388-00
-45	131-2324-00			1	..CONN,EDGE CARD: :	31781	307-040-526-300
-46	131-0608-00			17	..TERMINAL,PIN:0.365 L X 0.025 BRZ GLD PL	80009	131-0608-00
-47	344-0326-00			10	..CLIP,ELECTRICAL:FUSE,BRASS	75915	102071
-48	-----			3	..TRANSISTOR:(SEE A30A1Q2021,A30A1Q2024, ..A30A1Q3022 REPL) ..(ATTACHING PARTS)		
-49	211-0007-00			3	..SCREW,MACHINE:4-40 X 0.188,PNH,STL	93907	ORDER BY DESCR
-50	210-1171-00			3	..WASHER,SHLDR:0.12 ID X 0.143 OD X 0.07 D	00261	A7148516P2
-51	342-0354-00			3	..INSULATOR,PLATE:TRANSISTOR ..(END ATTACHING PARTS)	55285	7403-09FR-52
-52	214-3433-00			1	..HEAT SINK,XSTR:TO-220,ALUMINUM ..(ATTACHING PARTS)	80009	214-3433-00
-53	211-0014-00			2	..SCREW,MACHINE:4-40 X 0.5,PNH,STL ..(END ATTACHING PARTS)	93907	ORDER BY DESCR
-54	361-0345-00			2	..SPACER,SLEEVE:0.17 L X 0.125 ID,AL	80009	361-0345-00
-55	-----			2	..TRANSISTOR:(SEE A30A1Q2061, ..A30A1Q2071 REPL) ..(ATTACHING PARTS)		
-56	210-0455-00			2	..NUT,PLAIN,HEX:0.25-28 X 0.375,BRS NP	73743	3089-402
-57	210-0011-00			2	..WASHER,LOCK:0.25 ID,INTL,0.025 THK,STL	09772	1214-00-00-0541C
-58	210-1355-00			2	..WASHER,SHLDR:0.255 ID X 0.6 OD	80009	210-1355-00
-59	342-0517-00			2	..INSULATOR,WSHR:0.26 ID X 1.0 OD X 0.005	80009	342-0517-00
-60	210-0348-00			2	..TERMINAL,LUG:0.265 ID,PLAIN,BRS TIN PL ..(END ATTACHING PARTS)	86928	5407-2
-61	214-2972-02			1	..HEAT SINK,XSTR:TO-61,AL ..(ATTACHING PARTS)	80009	214-2972-02
-62	211-0507-00			2	..SCREW,MACHINE:6-32 X 0.312,PNH,STL ..(END ATTACHING PARTS)	83385	ORDER BY DESCR
-63	129-0575-00			2	..SPACER,POST:0.312 L,6-32,BRS,0.312 OD ..(ATTACHING PARTS)	80009	129-0575-00
-64	210-0407-00			1	..NUT,PLAIN,HEX:6-32 X 0.25,BRS CD PL ..(END ATTACHING PARTS)	73743	3038-402
-65	385-0100-00			1	..SPACER,POST:0.5 L W/6-32 THD THRU,NYLON	80009	385-0100-00
-66	346-0032-00			1	..STRAP,RETAINING:0.075 DIA X 4.0 L,MLD RBR	98159	2829-75-4
-67	-----			4	..DIODES:(SEE A30A1CR4061,A30A1CR4062, ..A30A1CR4063,A30A1CR4065 REPL) ..(ATTACHING PARTS)		
-68	211-0314-00			1	..SCREW,MACHINE:4-40 X 1.0 L,PNH,NYL	85480	PHNY-023NA
-69	129-0214-00			3	..SPACER,POST:0.2 L,6-32 THRU,DEL RIN,0.25 OD	80009	129-0214-00
-70	220-0665-00			1	..NUT,SLFLKG,HEX:4-40 X 0.25 HEX,NYLON ..(END ATTACHING PARTS)	23050	ORDER BY DESCR
-71	131-2250-00			1	..CONN,HDR PWR:	80009	131-2250-00
-72	136-0352-00	B010100	B020623	2	..SOCKET,PIN TERM:	80009	136-0352-00
-73	175-9130-00			1	..CA ASSY,SP,ELEC:3,18 AWG,4.5 L,0-8	80009	175-9130-00
-74	342-0566-00			1	..INSULATOR,PLATE:HEAT SINK,SILICON RUBBER	18565	ORDER BY DESCR
-75	214-3269-00			1	..HEAT SINK,DIODE:(6) DO4,AL ..(ATTACHING PARTS)	80009	214-3269-00
-76	211-0012-01			2	..SCREW,MACHINE:4-40 X 0.375,PNH,STL ..(END ATTACHING PARTS)	26233	ORDER BY DESCR
77	343-0144-00			2	..CLAMP,LOOP:0.125 ID,NYLON ..(ATTACHING PARTS)	TK1452	ORDER BY DESCR
	210-0586-00			2	..NUT,PL,ASSEM WA:4-40 X 0.25,STL CD PL ..(END ATTACHING PARTS)	78189	211-041800-00
	-----			2	..SWITCH POWER:(SEE A30S300,A30S301 REPL)		

Replaceable Mechanical Parts
494A/494AP Service Vol.2

Fig. & Index No.	Tektronix Part No.	Serial/Assembly No. Effective	Discnt	Qty	12345 Name & Description	Mfr. Code	Mfr. Part No.
3-					.(ATTACHING PARTS)		
-80	210-0586-00			2	.NUT, PL, ASSEM WA:4-40 X 0.25, STL CD PL	78189	211-041800-00
-81	211-0016-00			1	.SCREW, MACHINE:4-40 X 0.625, PNH, STL	TK0435	ORDER BY DESCR
-82	343-0144-00			1	.CLAMP, LOOP:0.125 ID, NYLON	TK1452	ORDER BY DESCR
					.(END ATTACHING PARTS)		
-83	342-0460-01			1	.INSULATOR, PLATE: POWER SWITCH, POLYESTER	80009	342-0460-01
-84	386-5102-00			1	.PLATE, MOUNTING: POWER SWITCH	80009	386-5102-00
					.(ATTACHING PARTS)		
-85	210-0586-00			2	.NUT, PL, ASSEM WA:4-40 X 0.25, STL CD PL	78189	211-041800-00
					.(END ATTACHING PARTS)		
-86	200-0237-04			1	.COVER, FUHLR: PLASTIC	80009	200-0237-04
-87	-----			1	.FILTER, RFI: (SEE A30FL302 REPL)		
					.(ATTACHING PARTS)		
-88	210-0586-00			2	.NUT, PL, ASSEM WA:4-40 X 0.25, STL CD PL	78189	211-041800-00
-89	210-0004-00			2	.WASHER, LOCK: #4 INTL, 0.015 THK, STL	77900	1204-00-00-0541C
					.(END ATTACHING PARTS)		
-90	342-0570-00			1	.INSULATOR, FILM: TOROID ASSY, POLYIMIDE	80009	342-0570-00
-91	342-0439-00			2	.INSULATOR, PLATE: CIRCUIT BOARD, POLYESTER	80009	342-0439-00
-92	210-0202-00			1	.TERMINAL, LUG: 0.146 ID, LOCKING, BRZ TIN PL	86928	A-373-158-2
					.(ATTACHING PARTS)		
-93	210-0457-00			1	.NUT, PL, ASSEM WA:6-32 X 0.312, STL CD PL	78189	511-061800-00
					.(END ATTACHING PARTS)		
-94	334-3379-04			1	.MARKER, IDENT: MKD GROUND SYMBOL (12)	80009	334-3379-04
-95	343-0013-00	B010100	B010541	4	.CLAMP, LOOP: 0.375 ID, PLASTIC	06915	ORDER BY DESCR
	343-0013-00	B010542		1	.CLAMP, LOOP: 0.375 ID, PLASTIC	06915	ORDER BY DESCR
	343-0006-00	B010542		2	.CLAMP, LOOP: 0.5 ID, PLASTIC	06915	ORDER BY DESCR
	343-0549-00	B010542		1	.STRAP, TIEDOWN, E: 0.098 W X 4.0 L, ZYTEL	06383	PLTIM
					.(ATTACHING PARTS)		
-96	210-0586-00			4	.NUT, PL, ASSEM WA:4-40 X 0.25, STL CD PL	78189	211-041800-00
-97	210-0863-00			4	.WSHR, LOOP CLAMP: 0.091 ID U/W 0.5 W CLP, STL	95987	C191
					.CD PL		
-98	211-0198-00			2	.SCREW, MACHINE: 4-40 X 0.438, PNH, STL	TK0435	ORDER BY DESCR
					.(END ATTACHING PARTS)		
-99	343-0549-00			2	.STRAP, TIEDOWN, E: 0.098 W X 4.0 L, ZYTEL	06383	PLTIM
-100	175-4131-00			1	.CA ASSY, SP, ELEC: 10, 26 AWG, 13.0 L, RIBBON	TK1375	175-4131-00
	352-0168-00			1	.HLDR, TERM CONN: 10 WIRE, BLACK	80009	352-0168-00
	352-0169-00			1	.HLDR, TERM CONN: 2 WIRE, BLACK	80009	352-0169-00
-101	129-0823-00			2	.SPACER, POST: 0.885 L, 0.5 HEX	80009	129-0823-00
-102	-----			1	.CABLE ASSY, RF: (SEE A30W620 REPL)		
-103	337-0925-05	B010100	B020960	1	.SHLD GSKT, ELEK: 30.75 L	TK1375	ORDER BY DESCR
	337-0925-02	B020961		1	.SHLD GSKT, ELEK: BULK	53217	21-00352
-104	378-0112-00			1	.GRILLE, PLASTIC:	80009	378-0112-00
					.(ATTACHING PARTS)		
-105	211-0602-00			2	.SCR, ASSEM WSHR: 6-32 X 0.438, PNH, BRS NP, POZ	01536	ORDER BY DESCR
					.(END ATTACHING PARTS)		
-106	131-0106-02			4	.CONN, RF JACK:	80009	131-0106-02
-107	131-0126-00			1	.CONN, RF::	80009	131-0126-00
-108	131-0771-00			1	.CONN, CIRC::	80009	131-0771-00
-109	333-3002-00	B010100	B010287	1	.PANEL, REAR:	80009	333-3002-00
	334-7184-00	B010288		1	.MARKER, IDENT: MARKED PROBE POWER	80009	334-7184-00
-110	333-2647-03			1	.PANEL, REAR:	80009	333-2647-03
					.(494A ONLY)		
					.(ATTACHING PARTS)		
-111	211-0038-00			2	.SCREW, MACHINE: 4-40 X 0.312, FLH, 100 DEG, STL	93907	ORDER BY DESCR
-112	211-0086-00			2	.SCREW, MACHINE: 4-40 X 0.75, FLH, 100 DEG, STL	80009	211-0086-00
					.(END ATTACHING PARTS)		
-113	386-3948-03			1	.PANEL, V SEL:	80009	386-3948-03
					.(ATTACHING PARTS)		
-114	220-0601-00			2	.NUT, PLAIN, CAP: 4-40 X 0.25 HEX, BRS NP	73743	93261-03
					.(END ATTACHING PARTS)		
-115	-----			1	.FILTER, RFI: (SEE A30FL301 REPL)		
					.(ATTACHING PARTS)		
-116	211-0097-01			2	.SCREW, MACHINE: 4-40 X 0.312, PNH, STL	26233	ORDER BY DESCR
					.(END ATTACHING PARTS)		
-117	200-2264-00			1	.CAP, FUSEHOLDER: 3AG FUSES	S3629	FEK 031 1666
-118	204-0833-00			1	.BODY, FUSEHOLDER: 3AG & 5 X 20MM FUSES	TK0861	031 1653 (FEU)
-119	348-0655-00			1	.SEAL, FUSE:	80009	348-0655-00
-120	380-0629-01			1	.HOUSING, REAR: CIRCUIT BOARD	80009	380-0629-01

Replaceable Mechanical Parts
494A/494AP Service Vol.2

Fig. & Index No.	Tektronix Part No.	Serial/Assembly No. Effective Dscont	Qty	12345 Name & Description	Mfr. Code	Mfr. Part No.
3-121 -122	354-0607-00 -----		1 1	.PACKING, PREFMD: 7.315 ID X 0.062 OD X SECT .CKT BOARD ASSY: RELAY DRIVER .(SEE A30A76 REPL) .(ATTACHING PARTS)	80009	354-0607-00
-123	211-0116-00		2	.SCR, ASSEM WSHR: 4-40 X 0.312, PNH, BRS, NP, POZ .(END ATTACHING PARTS) .CKT BOARD ASSY INCLUDES:	77900	ORDER BY DESCR
-124	131-2323-00		1	..CONN, EDGE CARD: :	31781	307-024-526-300
-125	348-0599-00		1	..SEAL, CONNECTOR: ACCESSORY BUS, VINYL	80009	348-0599-00
-126	131-1437-00		1	..CONN, RCPT, ELEC: D SER, 25 FEM CONT ..(ATTACHING PARTS)	71468	08255-F179
-127	131-0890-00		2	..SCREW LOCK: 4-40 X 0.312 L HEX HD, STLCD PL ..(END ATTACHING PARTS)	71468	D 20418-2
-128	131-0608-00		4	..TERMINAL, PIN: 0.365 L X 0.025 BRZ GLD PL	80009	131-0608-00
-129	361-1044-00		2	..SPACER, SLEEVE: 0.232 L X 0.125 ID, AL	80009	361-1044-00
-130	252-0714-00		1	..RUBBER ROD: 0.062 X 0.094, SILICONE	80009	252-0714-00
-131	348-0056-00		2	..GROMMET, PLASTIC: GRAY, ROUND, 0.332 ID	80009	348-0056-00
-132	129-0815-01		2	..SPACER, POST: 0.24 L, 0.375 OD ..(ATTACHING PARTS)	80009	129-0815-01
-133	210-0583-00		2	..NUT, PLAIN, HEX: 0.25-32 X 0.312, BRS CD PL	73743	2X-20319-402
-134	210-0046-00		2	..WASHER, LOCK: 0.261 ID, INTL, 0.018 THK, STL ..(END ATTACHING PARTS)	77900	1214-05-00-0541C
-135	129-0815-00		2	..SPACER, POST: 0.23 L, 0.375 OD ..(ATTACHING PARTS)	80009	129-0815-00
-136	210-0583-00		2	..NUT, PLAIN, HEX: 0.25-32 X 0.312, BRS CD PL	73743	2X-20319-402
-137	210-0046-00		2	..WASHER, LOCK: 0.261 ID, INTL, 0.018 THK, STL ..(END ATTACHING PARTS)	77900	1214-05-00-0541C
-138	-----		1	..SWITCH, LEVER: 1 POLE, 3 POSN ..(SEE A30S302 REPL) ..(ATTACHING PARTS)		
-139	211-0097-01		2	..SCREW, MACHINE: 4-40 X 0.312, PNH, STL	26233	ORDER BY DESCR
-140	210-0586-00		2	..NUT, PL, ASSEM WA: 4-40 X 0.25, STL CD PL ..(END ATTACHING PARTS)	78189	211-041800-00
-141	426-1466-05		1	..FRAME SECT, SA: REAR	80009	426-1466-05
-142	175-4189-01		1	..CABLE ASSY, RF: 50 OHM COAX, 7.0 L, 9-5	TK1375	175-4189-01
-143	386-4439-00		1	..PLATE, CLAMPING: ALUMINUM ..(ATTACHING PARTS)	80009	386-4439-00
-144	211-0097-01		2	..SCREW, MACHINE: 4-40 X 0.312, PNH, STL ..(END ATTACHING PARTS)	26233	ORDER BY DESCR
-145	348-0656-00		1	..PAD, CUSHIONING: 1.0 X 0.5 X 0.062	80009	348-0656-00
-146	-----		1	..CA ASSY, SP, ELEC: 11.0 INCH LONG, RIBBON ..(SEE A30W1011 REPL) ..(494AP ONLY)		
	352-0169-00		2	..HLDR, TERM CONN: 2 WIRE, BLACK ..(494AP ONLY)	80009	352-0169-00
-147	175-3944-01		1	..	80009	175-3944-01
	352-0168-00		1	..HLDR, TERM CONN: 10 WIRE, BLACK	80009	352-0168-00
-148	-----		1	..CA ASSY, SP, ELEC: 26, 26 AWG, 22.0 L RIBBON ..(SEE A30W560 REPL)		
-149	333-2647-02		1	..PANEL, REAR: ..(494AP ONLY)	80009	333-2647-02
-150	426-1733-00		1	..FRAME, DOOR: ..(494AP ONLY)	80009	426-1733-00
-151	200-2499-00		1	..DOOR, ACCESS: SWITCH ..(494AP ONLY)	80009	200-2499-00
-152	-----		1	..CKT BOARD ASSY: GPIB INTERFACE ..(SEE A30A57 REPL) ..(ATTACHING PARTS)		
-153	211-0116-00		2	..SCR, ASSEM WSHR: 4-40 X 0.312, PNH, BRS, NP, POZ ..(END ATTACHING PARTS)	77900	ORDER BY DESCR
-154	131-2203-02		1	..CONN, RIBBON: PCB, FEMALE, STR, 24 POS, 0.085 CT ..R, 0.135 TAIL, W/FLOAT BUSHING;(ATTACHING PARTS)	29587	57-20240-11(398)
-155	214-2871-00		2	..HARDWARE KIT: STANDOFF, STUD MOUNT W/NUT	TK1650	552633-3
-156	210-0804-00		2	..WASHER, FLAT: 0.17 ID X 0.375 OD X 0.032 ..(END ATTACHING PARTS)	86928	76430-000
-157	348-0598-00		1	..SEAL, CONNECTOR: GPIB BUS, VINYL ..(ATTACHING PARTS)	80009	348-0598-00

Replaceable Mechanical Parts
494A/494AP Service Vol.2

Fig. & Index No.	Tektronix Part No.	Serial/Assembly No. Effective Dscont	Qty	12345 Name & Description	Mfr. Code	Mfr. Part No.
3-158	211-0086-00		2	.. SCREW, MACHINE:4-40 X 0.75, FLH, 100 DEG, STL .. (END ATTACHING PARTS)	80009	211-0086-00
-159	361-1044-00		2	.. SPACER, SLEEVE:0.232 L X 0.125 ID, AL	80009	361-1044-00
-160	131-2230-00		1	.. CONN, HDR:FEEDTHRU/PCB, ;MALE, STR, 2 X 8, 0.1 C .. TR, 0.230 MLG X 0.230 MLG, 30 GOLD; ..	TK1483	082-0843-SD08
-161	131-0608-00		2	.. TERMINAL, PIN:0.365 L X 0.025 BRZ GLD PL	80009	131-0608-00
-162	129-0815-01		2	.. SPACER, POST:0.24 L, 0.375 OD .. (ATTACHING PARTS)	80009	129-0815-01
-163	210-0583-00		2	.. NUT, PLAIN, HEX:0.25-32 X 0.312, BRS CD PL	73743	2X-20319-402
-164	210-0046-00		2	.. WASHER, LOCK:0.261 ID, INTL, 0.018 THK, STL .. (END ATTACHING PARTS)	77900	1214-05-00-0541C

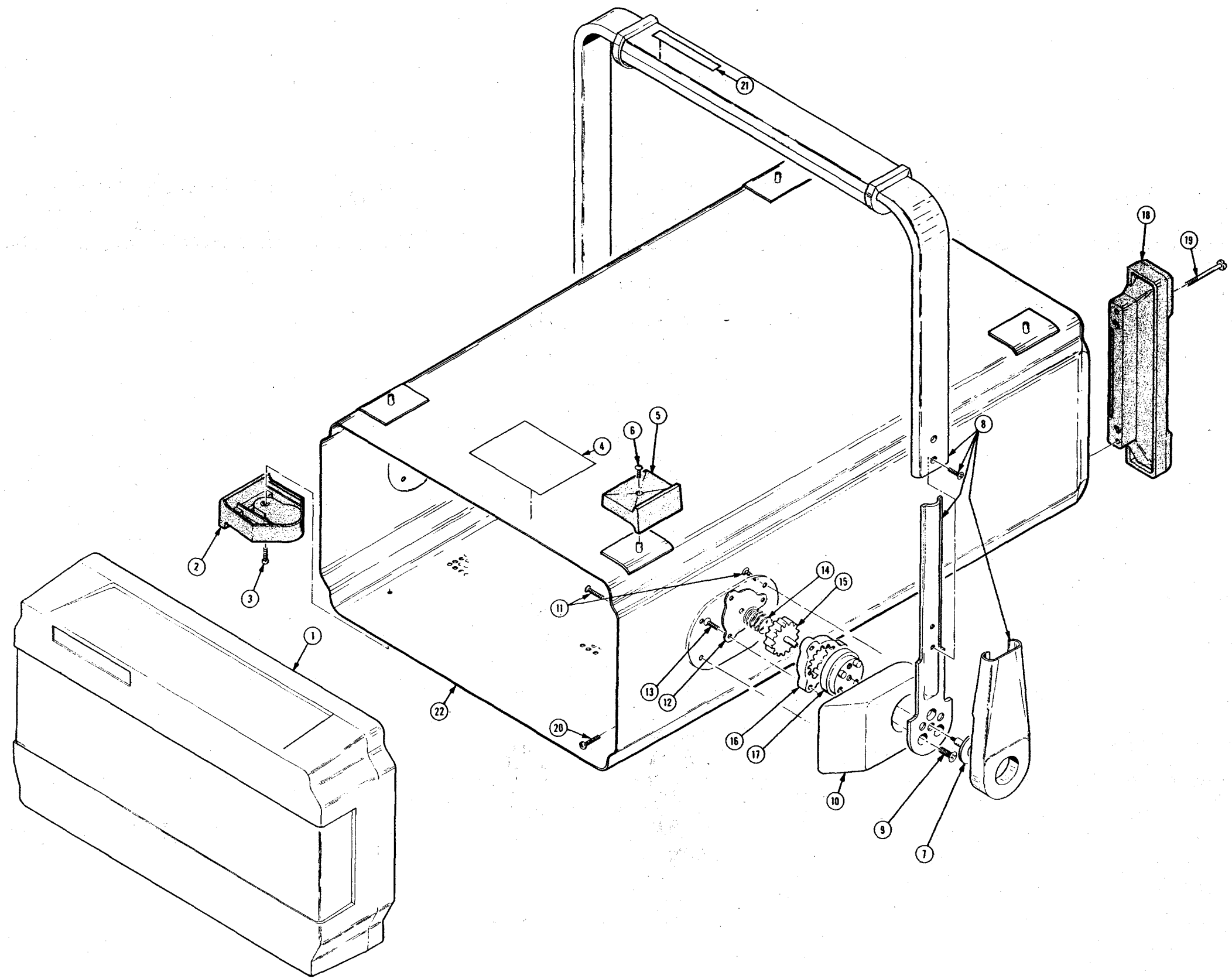

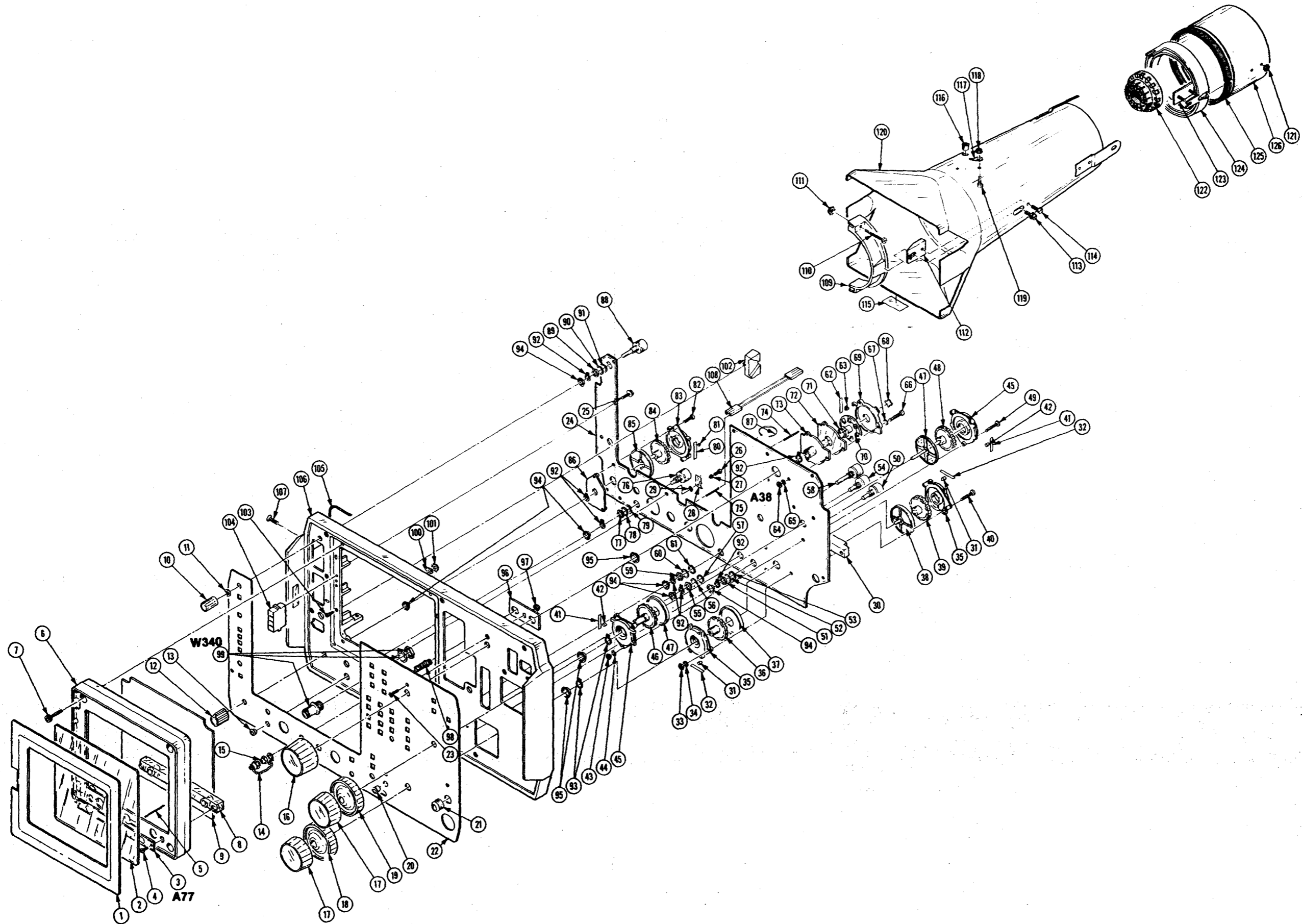

Date: 7-20-89
Product: See List

Change Reference: M66158 Rev 3
Manual Part No: See List

Product Group: 2E

INSTRUMENT	MANUAL	EFF/SN
2754/P Service 2	070-6098-00	B010249
2755/P Service 2	070-6033-01	B010294
2755A/AP Service 2	070-6033-01	B010105
2756P Service 2	070-6319-00	B010205
492B/BP Service 2	070-5566-01	B010130
492/P Service 2	070-3784-01	B056152
492A/AP Service 2	070-5566-01	B010747
494/P Service 2	070-4417-01	B011157
494A/AP Service 2	070-5561-00	B020616

Replace Change Reference M66158 revision 2 with M66158 revision 3.

CHANGE TO: ELECTRICAL PARTS LIST CHANGES

A16A1	670-0813-00	1ST LO INTERFACE CKT BD ASSY
A16	119-2741-01	OSCILLATOR,RF ASSY
W132	174-1454-00	CABLE ASSY,RF:50 OHM COAX 23.36L (OPTION 31 ONLY ON ALL ABOVE INSTRUMENTS EXCEPT 492B/BP 492/P, 492A/AP, 494/P, 494A/AP)

DELETE:

P133	015-1022-00	50 OHM TERMINATOR
A13	119-1019-00	POWER DIV ASSY
W130	175-2345-00	CABLE ASSY,RF:50 OHM COAX,10.29 L
W166	175-2763-00	CABLE ASSY,RF:50 OHM COAX,3.13 L
W132	174-0339-00	CABLE ASSY,RF:50 OHM COAX,17.56 L (2754/P, 2755/P, 2756P, 2755A/AP)
W132	174-2762-02	CABLE ASSY,RF:50 OHM COAX,17.56 L (492B/BP, 492/P, 492A/AP, 494/P, 494A/AP)

ADD:

W135	174-1354-00	CABLE ASSY,RF:50 OHM COAX,17.68 L (2754/P, 2755/P, 2756P, 2755A/AP)
W135	174-1336-00	CABLE ASSY,RF:50 OHM COAX,6.33 L
W136	174-1337-00	CABLE ASSY,RF:50 OHM COAX,14.93 L (492B/BP, 492/P, 492A/AP, 494/P, 494A/AP)

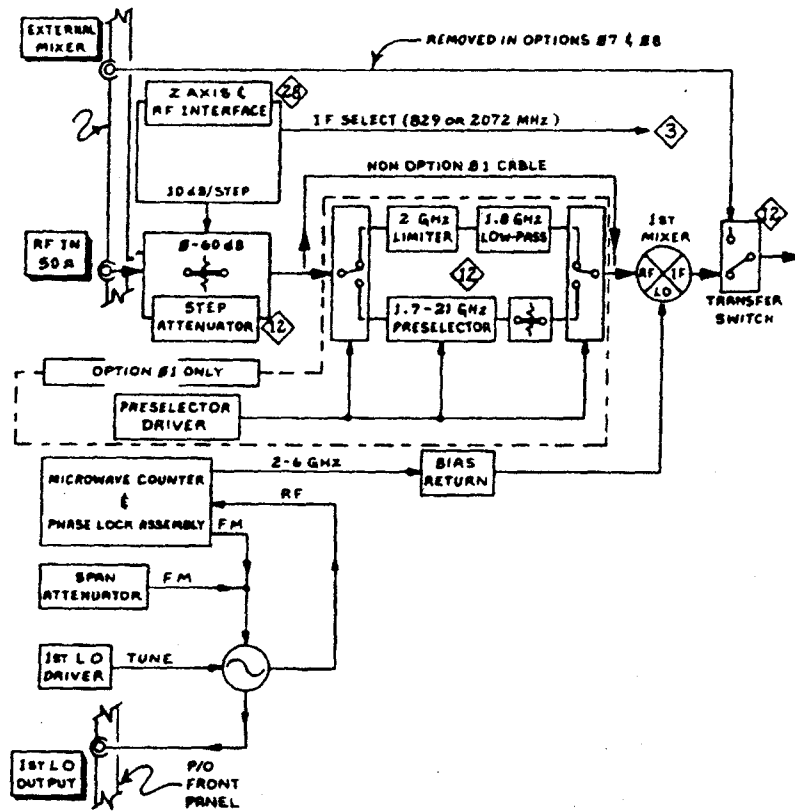

Partial Block Diagram of the 1st Converter showing the A13 Power Divider removed.

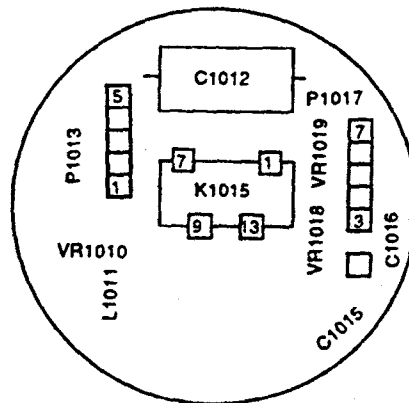

NEW A16A1 - 1ST LO Interface Circuit Board

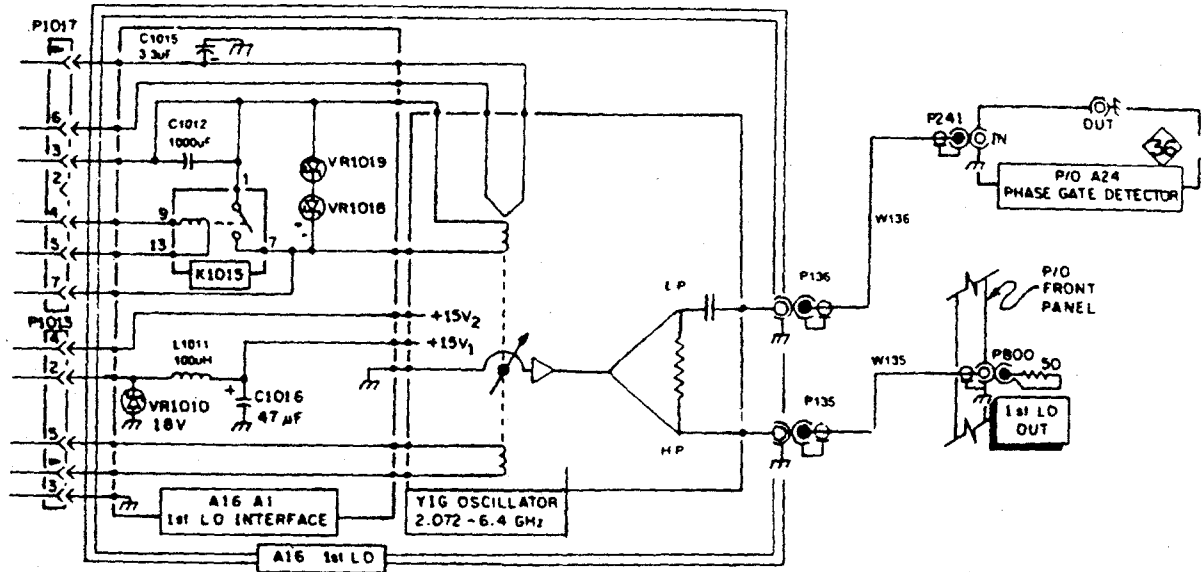

NEW Schematic for the A16 1st LO Assembly

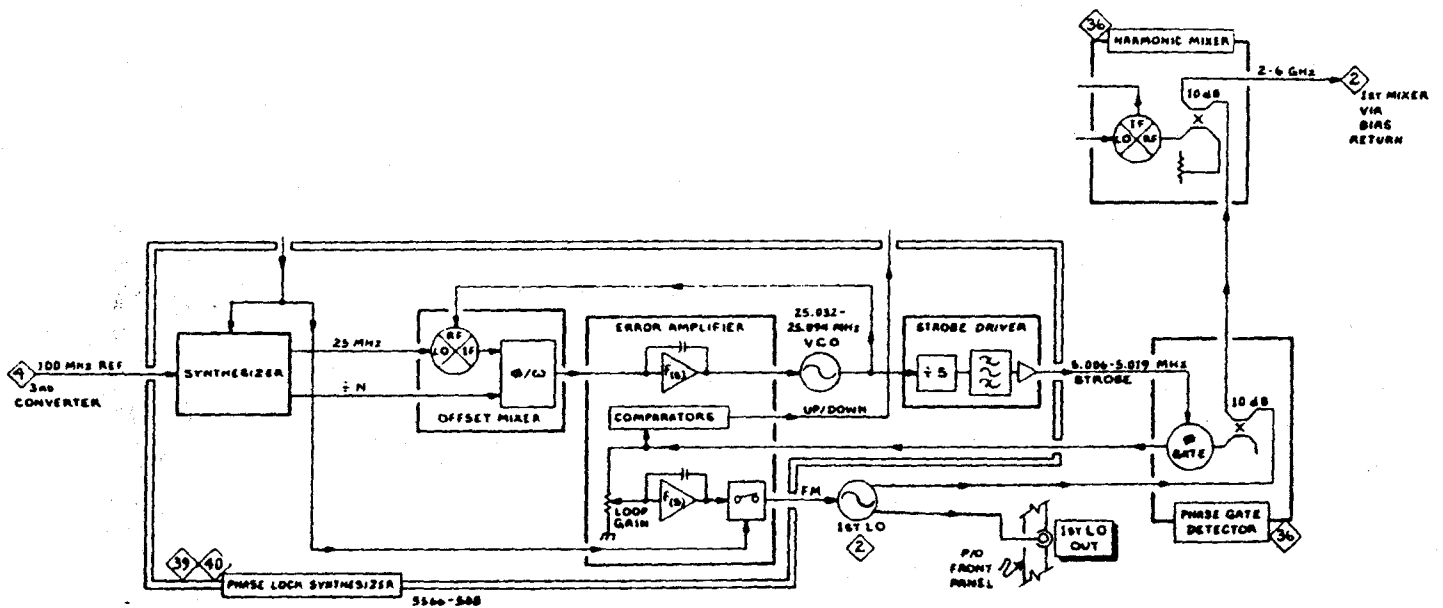

Partial Block Diagram of the Counter and Phase Lock Section showing the A13 Power Divider removed.

Date: 5-1-90
Product: see list

Change Reference: M67070
Manual Part No: see list

Product Group: 2E

INSTRUMENT	MANUAL	EFF/SN
492B/BP Serv. 2	070-5566-01	B030183
494AP Serv. 2	070-5561-00	B020634
495/P Serv. 2	070-5085-00	B030660
497P Serv. 2	070-7680-00	B010118
492PGM Serv. 2	070-7557-00	B010127
2753P Serv. 2	070-6307-00	B030182
2754/P Serv. 2	070-6098-00	B030100
2755AP Serv. 2	070-6033-01	B030184
2756P Serv. 2	070-6319-00	B020233

ELECTRICAL PARTS LIST

Change to:

A62	672-0187-02	LOG AMP ASSY
A62A1	670-9091-03	LOG AMP CIRCUIT BOARD ASSY
A62A1C2004	283-0167-00	CAP,FXD,CER DI: 1UF,10%,100V
A62A1C1119	283-5003-00	CAP,FXD,CER DI: 0.01UF,10%,50V
A62A1C2020	283-5003-00	CAP,FXD,CER DI: 0.01UF,10%,50V

Date: 3-12-91
Product: see list

Change Reference: M74739
Manual Part No: see list
Product Group: 2E

<u>INSTRUMENT</u>	<u>MANUAL</u>	<u>EFFECT/SN</u>
494AP serv 2	070-5561-00	B020718
492B/BP serv 2	070-5566-01	B030619
492PGM serv 2	070-7557-00	B010274
495/P serv 2	070-5085-00	B030786
497P serv 2	070-7680-00	B020209
2753P serv 2	070-6307-00	B020238
2754P serv 2	070-6098-00	B030548
2755AP serv 2	070-6033-01	B030225
2756P serv 2	070-6319-00	B020252

ELECTRICAL PARTS LIST

CHANGE TO:

A30	621-0024-02	POWER SUPPLY (494AP, 495P, 2753P, 2755AP, 2756P only)
A30	621-0030-02	POWER SUPPLY (495 OPT. 42 only)
A30	621-0031-02	POWER SUPPLY (494AP OPT. 42, 495P OPT. 42, 2753P OPT. 42, 2755AP OPT. 42, 2756P OPT. 42 only)
A30	621-0045-01	POWER SUPPLY (492B OPT. 42 only)
A30	621-0046-01	POWER SUPPLY (492BP OPT. 42, 497P OPT. 42 only)
A30	621-0047-01	POWER SUPPLY (492B only)
A30	621-0048-01	POWER SUPPLY (492BP, 497P only)

CHANGE TO:

A30	621-0061-01	POWER SUPPLY (492PGM only)
A30	621-0069-01	POWER SUPPLY (2754P only)
A30A1	670-8036-05	POWER SUPPLY ASSY
A30A1CR2061	152-0661-01	SEMICON DVC, DI
A30A1CR2063	152-0661-01	SEMICON DVC, DI
A30A1CR2065	152-0661-01	SEMICON DVC, DI
A30A1CR2079	152-0661-01	SEMICON DVC, DI

ADD:

A30A1CR2062	152-0661-01	SEMICON DVC, DI
A30A1CR2095	152-0661-01	SEMICON DVC, DI

PARTIAL SCHEMATIC A30A1 MAIN POWER SUPPLY
670-8036-05

BEFORE

AFTER

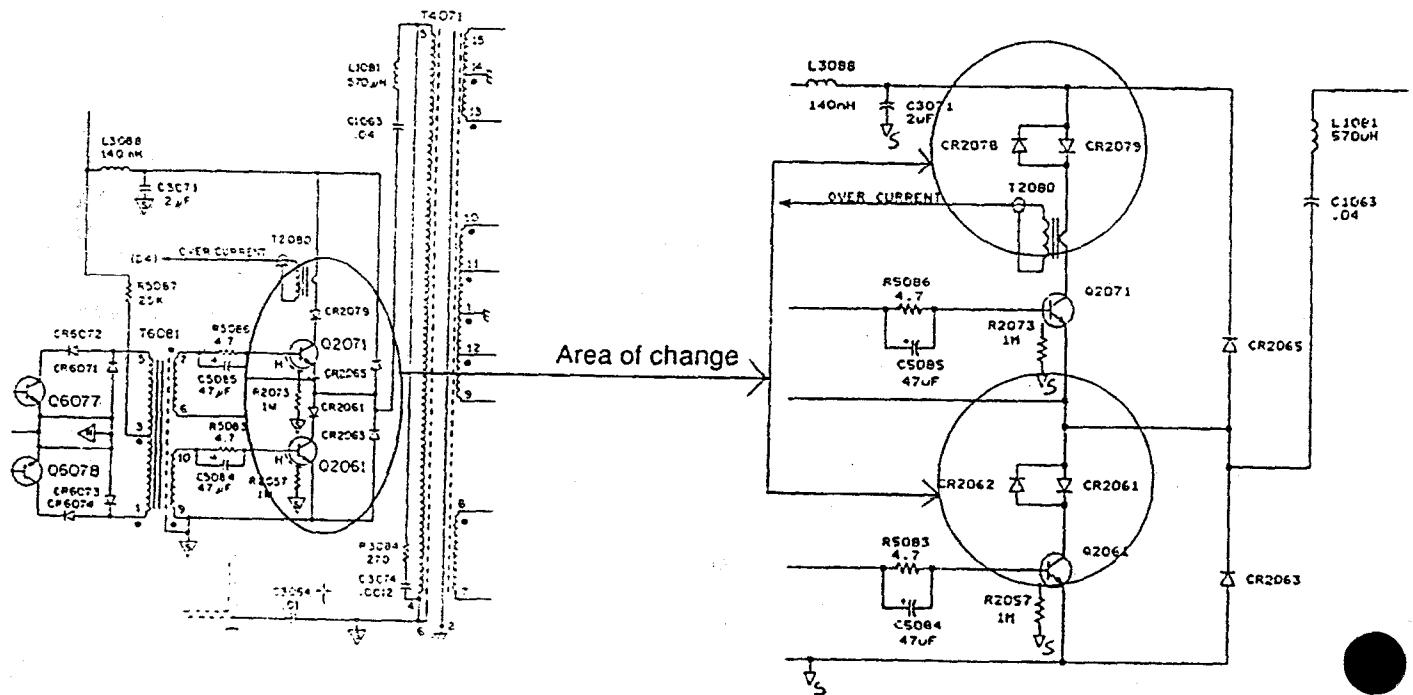

Date: 04-22-91
Product: See list

Change Reference: M74861
Manual Part No: See list

Product Group: 2E

INSTRUMENT	MANUAL	EFF/SN
2753P SERVICE 2	070-6307-00	B030242
2754P SERVICE 2	070-6098-00	B030551
2755AP SERVICE 2	070-6033-01	B030227
2756P SERVICE 2	070-6319-00	B020254
492B/BP SERVICE 2	070-5566-01	B030633
492PGM SERVICE 2	070-7557-00	B010281
494AP SERVICE 2	070-5561-00	B020720
495/P SERVICE 2	070-5085-00	B030787
497P SERVICE 2	070-7680-00	B020212

NOTE : At Figure 3-23 in all Service manuals for all instruments, (3) cable clamps (343-0144-00) were replaced by (2) cable clamps (343-1503-00) and (1) cable clamp (343-1502-00). See the diagram on page 3 of this insert for the correct placement of the replacement clamps.

MECHANICAL PARTS LIST CHANGE

CHANGE TO:

INSTRUMENT	FIG & INDEX	QTY	PART NO.	DESCRIPTION
2753P	3-23	(1)	343-1502-00	CLAMP, CABLE
	3-23	(2)	343-1503-00	CLAMP, CABLE
	3-77	(2)	343-1503-00	CLAMP, CABLE
	3-82	(1)	343-1503-00	CLAMP, CABLE
	6-56	(1)	343-1503-00	CLAMP, CABLE
	10-18	(1)	343-0119-00	CLAMP, CABLE
2754P	3-23	(1)	343-1502-00	CLAMP, CABLE
	3-23	(2)	343-1503-00	CLAMP, CABLE
	3-74	(2)	343-1503-00	CLAMP, CABLE
	3-79	(1)	343-1503-00	CLAMP, CABLE
	6-5	(1)	343-1503-00	CLAMP, CABLE
	6-102	(1)	343-1502-00	CLAMP, CABLE
2755AP	3-23	(1)	343-1502-00	CLAMP, CABLE
	3-23	(2)	343-1503-00	CLAMP, CABLE
	3-77	(2)	343-1503-00	CLAMP, CABLE
	3-82	(1)	343-1503-00	CLAMP, CABLE
	8-5	(1)	343-1503-00	CLAMP, CABLE
	8-107	(1)	343-1502-00	CLAMP, CABLE
	9-54	(1)	343-1503-00	CLAMP, CABLE
	9-55	(1)	211-0007-00	SCREW, MACHINE
	13-18	(1)	343-0119-00	CLAMP, CABLE

CHANGE TO:

INSTRUMENT	FIG & INDEX	QTY	PART NO.	DESCRIPTION
2756P	3-23	(1)	343-1502-00	CLAMP, CABLE
	3-23	(2)	343-1503-00	CLAMP, CABLE
	3-77	(2)	343-1503-00	CLAMP, CABLE
	3-82	(1)	343-1503-00	CLAMP, CABLE
	6-5	(1)	343-1503-00	CLAMP, CABLE
	6-107	(1)	343-1502-00	CLAMP, CABLE
	7-50	(1)	343-1503-00	CLAMP, CABLE
	7-51	(1)	211-0007-00	SCREW, MACHINE
	11-18	(1)	343-0119-00	CLAMP, CABLE
492B/BP	3-23	(1)	343-1502-00	CLAMP, CABLE
	3-23	(2)	343-1503-00	CLAMP, CABLE
	3-77	(2)	343-1503-00	CLAMP, CABLE
	3-82	(1)	343-1503-00	CLAMP, CABLE
	8-5	(1)	343-1503-00	CLAMP, CABLE
	8-107	(1)	343-1502-00	CLAMP, CABLE
	9-54	(1)	343-1503-00	CLAMP, CABLE
	9-52	(1)	211-0007-00	SCREW, MACHINE
	13-19	(1)	343-0119-00	CLAMP, CABLE
492PGM	3-23	(1)	343-1502-00	CLAMP, CABLE
	3-23	(2)	343-1503-00	CLAMP, CABLE
	3-77	(2)	343-1503-00	CLAMP, CABLE
	3-82	(1)	343-1503-00	CLAMP, CABLE
	6-5	(1)	343-1503-00	CLAMP, CABLE
	6-107	(1)	343-1502-00	CLAMP, CABLE
494AP	3-23	(1)	343-1502-00	CLAMP, CABLE
	3-23	(2)	343-1503-00	CLAMP, CABLE
	3-77	(2)	343-1503-00	CLAMP, CABLE
	3-82	(1)	343-1503-00	CLAMP, CABLE
	6-5	(1)	343-1503-00	CLAMP, CABLE
	6-107	(1)	343-1502-00	CLAMP, CABLE
	7-50	(1)	343-1503-00	CLAMP, CABLE
	7-51	(1)	211-0007-00	SCREW, MACHINE
9-18	(1)	343-0119-00	CLAMP, CABLE	
495/P	3-23	(1)	343-1502-00	CLAMP, CABLE
	3-23	(2)	343-1503-00	CLAMP, CABLE
	3-74	(2)	343-1503-00	CLAMP, CABLE
	3-79	(1)	343-1503-00	CLAMP, CABLE
	6-56	(1)	343-1503-00	CLAMP, CABLE
	10-23	(1)	343-0119-00	CLAMP, CABLE
497P	3-23	(1)	343-1502-00	CLAMP, CABLE
	3-23	(2)	343-1503-00	CLAMP, CABLE
	3-77	(2)	343-1503-00	CLAMP, CABLE
	3-82	(1)	343-1503-00	CLAMP, CABLE
	6-107	(1)	343-1502-00	CLAMP, CABLE

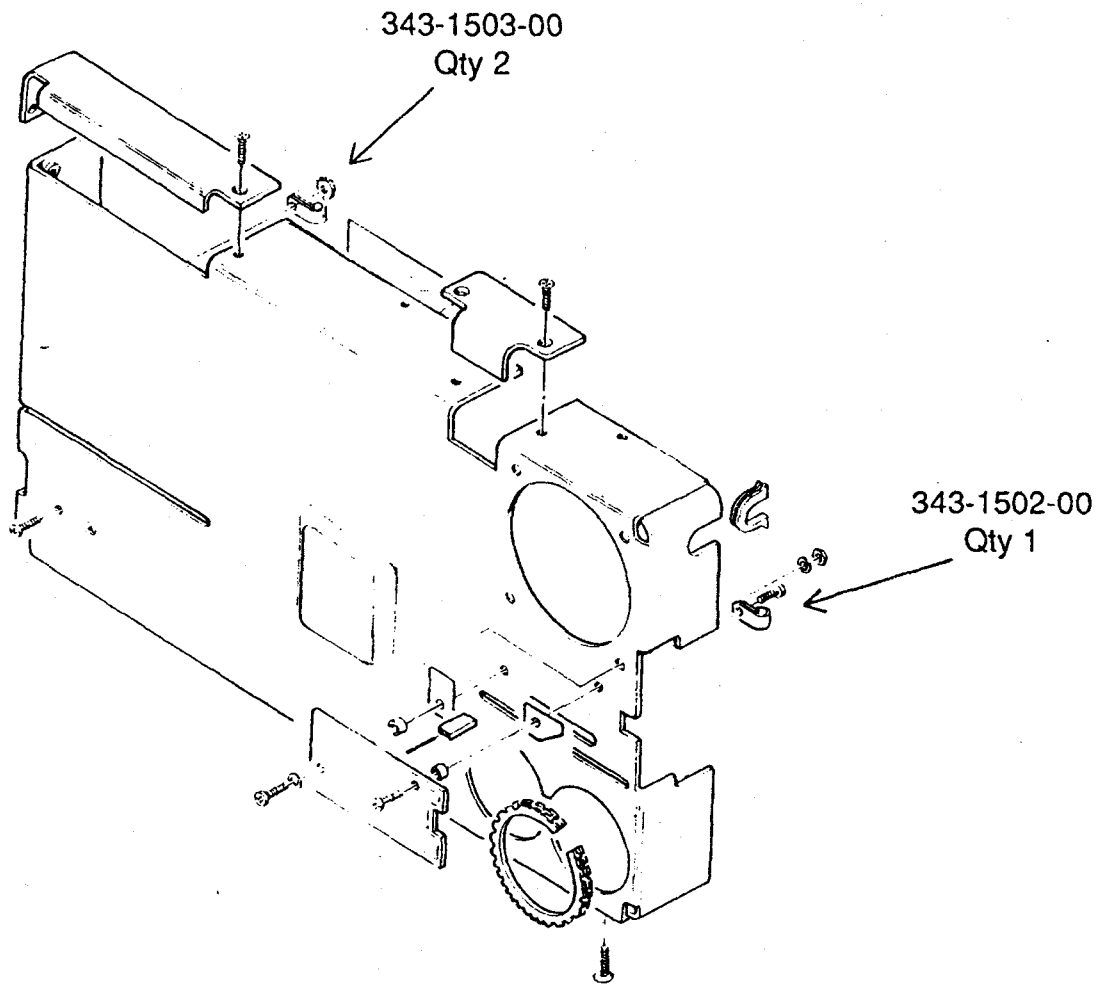

Date: 04-30-91
Product: see list

Change Reference: M73913/M74682
Manual Part No: see list Product Group: 2E

INSTRUMENT	MANUAL	SERIAL NUMBER
492B/BP serv 2	070-5566-01	B030578
492PGM serv 2	070-7557-00	B010239
494AP serv 2	070-5561-00	B020701
495/P serv 2	070-5085-00	B030764
497P serv 2	070-7680-00	B020191
2753P serv 2	070-6307-00	B030219
2754P serv 2	070-6098-00	B030528
2755AP serv 2	070-6033-01	B030219
2756P serv 2	070-6319-00	B020248

MECHANICAL PART CHANGES

CHANGE TO:

8-60	214-2769-00		HEAT SINK, OSC (492B/BP)
6-60	214-2769-00		HEAT SINK, OSC (492PGM, 494AP, 497P, 2756P)
6-12	214-2769-00		HEAT SINK, OSC (495/P, 2753P)
7-58	214-2769-00		HEAT SINK, OSC (2755AP)
3-4	337-3368-00		SHIELD, ELEC: POWER SUPPLY (492B/BP, 492PGM, 494AP, 495/P, 497P, 2753P, 2754P, 2755AP, 2756P)
		QTY	
8-52	211-0016-00	1	SCREW MACHINE (492B/BP)
6-52	211-0016-00	1	SCREW MACHINE (494AP, 492PGM, 497P, 2756P)
6-4	211-0016-00	1	SCREW MACHINE (495/P, 2753P)
7-50	211-0016-00	1	SCREW MACHINE (2755AP)

ADD:

- | | | |
|-------------|---|--|
| 348-1246-00 | 2 | PAD,CUSHIONING
(Adhere to Power Supply Shield, see diagram A)
(Adhere to A16 Assy on RF Deck, See diagram B) |
| 348-1255-00 | 1 | PAD,CUSHIONING
(Adhere to A16 Assy on RF Deck, See diagram B) |
| 348-1256-00 | 1 | PAD,CUSHIONING
(Adhere to A16 Assy on RF Deck, See diagram B) |

DIAGRAM A

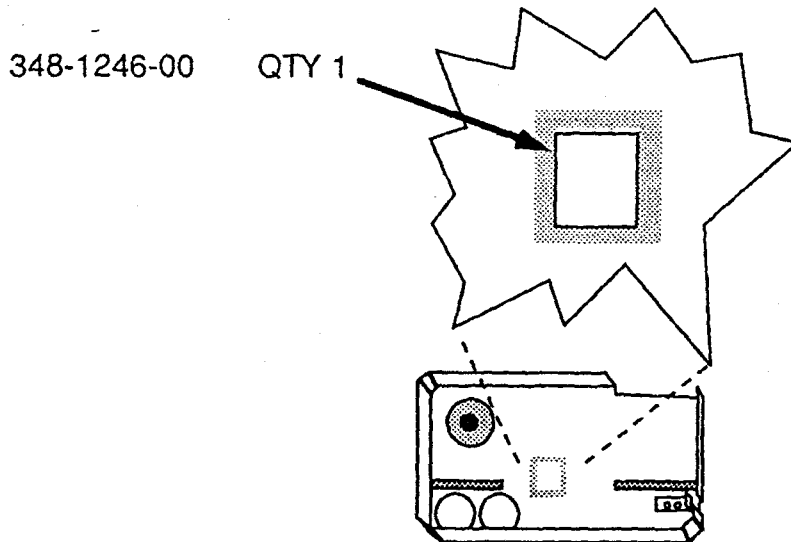
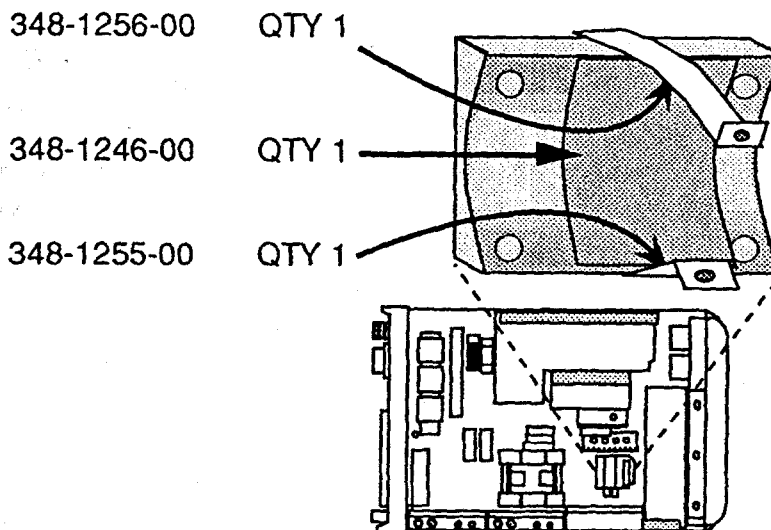

DIAGRAM B



Date: 02-03-92

Change Reference: M75984

Product: See List

Manual Part No: See List

<u>DESCRIPTION</u>		<u>Product Group 2E</u>
<u>Instrument</u>	<u>Manual Number</u>	<u>Starting Serial Number</u>
492BP Service 2	070-5566-01	B030671
492PGM Service 2	070-7557-00	B010337
494AP Service 2	070-5561-00	B020747
495P Service 2	070-5085-00	B030262
497P Service 2	070-7680-00	B020254
2753P Service 2	070-6307-00	B030262
2754P Service 2	070-6098-00	B030564
2755AP Service 2	070-6033-01	B030239
2756P Service 2	070-6319-00	B020270

ELECTRICAL PARTS LIST CHANGES

CHANGE TO:

<u>CIRCUIT NO.</u>	<u>PART NUMBER</u>	<u>DESCRIPTION</u>
A61	672-0163-03	VERTICAL DIGITAL STORAGE ASSY
A61A1	670-9099-03	CIRCUIT BRD ASSY:VERTICAL DIGITAL INTERFACE
A61A1R1035	321-0185-09	RES,FXD,FILM:825 OHM,1%,0.125W
A61A1R1036	321-0217-00	RES,FXD,FILM:1.78K OHM,1%,0.125W

MANUAL CHANGE INFORMATION

Date: 03-03-92

Change Reference: M74824

Product: See List

Manual Part No: See List

DESCRIPTION			Product Group 2E
<u>Instrument</u>	<u>Manual Number</u>	<u>Starting Serial Number</u>	
492BP Service 2	070-5566-01	B030685	
492PGM Service 2	070-7557-00	B010344	
494AP Service 2	070-5561-00	B020740	
495P Service 2	070-5085-00	B030821	
497P Service 2	070-7680-00	B020257	
2753P Service 2	070-6307-00	B030268	
2754P Service 2	070-6098-00	B030578	
2755AP Service 2	070-6033-01	B030241	
2756P Service 2	070-6319-00	B020270	

ELECTRICAL PARTS LIST CHANGES

CHANGE TO:

<u>CIRCUIT NO.</u>	<u>PART NUMBER</u>	<u>DESCRIPTION</u>
A50	119-1992-06	PHASE LOCK ASSY
A50A2	670-9068-01	CIRCUIT BOARD ASSY:STROBE DRIVER
A50A2C1014	290-5039-00	CAP,FXD,ALUMINUM:10UF,20%,50V
A50A2C1030	290-5039-00	CAP,FXD,ALUMINUM:10UF,20%,50V
A50A2U1015	156-5510-00	IC,DGTL:FTTL,4-BIT UP/DOWN COUNTER

Date: 3-16-92

Change Reference: M74829

Product: See list

Manual Part No: See list

<u>DESCRIPTION</u>		<u>Product Group 2E</u>
<u>INSTRUMENT</u>	<u>MANUAL NUMBER</u>	<u>STARTING SERIAL NUMBER</u>
492BP SERVICE 2	070-5566-01	B030774
492PGM SERVICE 2	070-7557-00	B010365
494AP SERVICE 2	070-5561-00	B020765
495P SERVICE 2	070-5085-00	B030835
497P SERVICE 2	070-6307-00	B020283
2753P SERVICE 2	070-6307-00	B030283
2754P SERVICE 2	070-6098-00	B030579
2755AP SERVICE 2	070-6033-01	B030243
2756P SERVICE 2	070-6319-00	B020272

ELECTRICAL PARTS LIST CHANGES

CHANGE TO:

<u>CIRCUIT #</u>	<u>PART #</u>	<u>DESCRIPTION</u>
A56	671-2123-01	CIRCUIT BOARD ASSY:GPIB
A56	671-0030-02	CIRCUIT BOARD ASSY:GPIB (OPTION 45 ONLY)
A56C1056	290-5039-00	CAP,FXD,ALUMINUM:10UF,20%,50V
A56C4051	290-5039-00	CAP,FXD,ALUMINUM:10UF,20%,50V

		DESCRIPTION	Product Group 2E
<u>Instrument</u>	<u>Manual Number</u>	<u>Starting Serial Number</u>	
492BP Service 2	070-5566-01	B030778	
492PGM Service 2	070-7557-00	B010369	
494AP Service 2	070-5561-00	B020772	
495P Service 2	070-5085-00	B030842	
497P Service 2	070-7680-00	B020280	
2753P Service 2	070-6307-00	B030289	
2754P Service 2	070-6098-00	B030579	
2755AP Service 2	070-6033-01	B030246	
2756P Service 2	070-6319-00	B020274	

ELECTRICAL PARTS LIST CHANGES

CHANGE TO:

<u>CIRCUIT NO.</u>	<u>PART NUMBER</u>	<u>DESCRIPTION</u>
A62	672-0187-03	CIRCUIT BOARD ASSY:LOG AMP
A62A1	670-9091-04	CIRCUIT BOARD ASSY:LOG AMP
A62A1C5066	290-5039-00	CAP,FXD,ELCTLTT:10UF,20%,50V
A62A1C4070	290-5039-00	CAP,FXD,ELCTLTT:10UF,20%,50V
A62A1C4074	290-5039-00	CAP,FXD,ELCTLTT:10UF,20%,50V
A62A1C4076	290-5039-00	CAP,FXD,ELCTLTT:10UF,20%,50V
A62A1C6065	290-5039-00	CAP,FXD,ELCTLTT:10UF,20%,50V
A62A1C6070	290-5039-00	CAP,FXD,ELCTLTT:10UF,20%,50V
A62A1C6072	290-5039-00	CAP,FXD,ELCTLTT:10UF,20%,50V
A62A1C2004	283-5004-00	CAP,FXD,CER,DI:0.1UF,10%,25V
A62A1C5074	290-5003-01	CAP,FXD,ELCTLTT:47UF,20%,10V
A62A1C5076	290-5003-01	CAP,FXD,ELCTLTT:47UF,20%,10V

Date: 05-18-92

Change Reference: M76729

Product: See List

Manual Part No: See List

DESCRIPTION			Product Group 2E
<u>Instrument</u>	<u>Manual Number</u>	<u>Starting Serial Number</u>	
492BP Service 2	070-5566-01	B030776	
492PGM Service 2	070-7557-00	B030776	
494AP Service 2	070-5561-00	B020769	
495P Service 2	070-5085-00	B030842	
497P Service 2	070-7680-00	B020293	
2753P Service 2	070-6307-00	B030284	
2754P Service 2	070-6098-00	B030579	
2755AP Service 2	070-6033-01	B030244	
2756P Service 2	070-6319-00	B020274	

ELECTRICAL PARTS LIST CHANGES

CHANGE TO:

<u>CIRCUIT NO.</u>	<u>PART NUMBER</u>	<u>DESCRIPTION</u>	<u>INSTRUMENT</u>
A30	621-0024-03	POWER SUPPLY ASSY	(494AP,495P,2753P, 2755AP & 2756P only)
A30	621-0031-03	POWER SUPPLY ASSY	(494AP Option 42, 495P Option 42, 2753P Option 42, 2755AP Option 42, 2756P Option 42 only)
A30	621-0043-02	POWER SUPPLY ASSY	(495P only)
A30	621-0046-02	POWER SUPPLY ASSY	(492BP Option 42 & 497P Option 42 only)
A30	621-0048-02	POWER SUPPLY ASSY	(492BP & 497P only)
A30	621-0061-02	POWER SUPPLY ASSY	(492PGM only)
A30	621-0069-02	POWER SUPPLY ASSY	(2754P only)
A30A1	670-8036-06	CBA:POWER SUPPLY ASSY	
A30A1R5087	308-0972-00	RES,FXD,WW:20K OHM 5% 12W	

CHANGE TO: (Continued)

<u>CIRCUIT NO.</u>	<u>PART NUMBER</u>	<u>DESCRIPTION</u>
A30A1Q6077	151-0444-04	TRANSISTOR,SIG:BIPOLAR,NPN:350V 500MA,40MHZ,AMPLIFIER;2N6517
A30A1Q6078	151-0444-04	TRANSISTOR,SIG:BIPOLAR,NPN:350V 500MA,40MHZ,AMPLIFIER;2N6517
A30A1CR2061	152-1165-00	DIODE,RECT;ULTRA FAST,600V 4A,50NS
A30A1CR2062	152-1165-00	DIODE,RECT;ULTRA FAST,600V 4A,50NS
A30A1CR2063	152-1165-00	DIODE,RECT;ULTRA FAST,600V 4A,50NS
A30A1CR2065	152-1165-00	DIODE,RECT;ULTRA FAST,600V 4A,50NS
A30A1CR2078	152-1165-00	DIODE,RECT;ULTRA FAST,600V 4A,50NS
A30A1CR2079	152-1165-00	DIODE,RECT;ULTRA FAST,600V 4A,50NS

Date: 05-19-92

Change Reference: M74827

Product: See List

Manual Part No: See List

<u>DESCRIPTION</u>		Product Group 2E
<u>Instrument</u>	<u>Manual Number</u>	<u>Starting Serial Number</u>
492BP Service 2	070-5566-01	B030804
492PGM Service 2	070-7557-00	B010420
494AP Service 2	070-5561-00	B020787
497P Service 2	070-7680-00	B020321
2753P Service 2	070-6307-00	B030298
2754P Service 2	070-6098-00	B030586
2755AP Service 2	070-6033-01	B030251
2756P Service 2	070-6319-00	B020278

ELECTRICAL PARTS LIST CHANGES

CHANGE TO:

<u>CIRCUIT NO.</u>	<u>PART NUMBER</u>	<u>DESCRIPTION</u>
A72	670-9090-05	CIRCUIT BOARD ASSY:SWEEP
A72C3030	290-5039-00	CAP,FXD,ELCTLT:10UF, 20%,50V
A72C3045	283-5025-00	CAP,FXD,CER DI:220PF, 5%,50V
A72R2031	321-5047-00	RES,FXD,FILM:100K OHM, 1%, 0.125W

ADD:

<u>CIRCUIT NO.</u>	<u>PART NUMBER</u>	<u>DESCRIPTION</u>
A72R3038	321-5040-00	RES,FXD,FILM:68.1K OHM, 1%, 0.125W
A72R3039	321-5041-00	RES,FXD,FILM:82.5K OHM, 1%, 0.125W

DELETE:

<u>CIRCUIT NO.</u>	<u>PART NUMBER</u>	<u>DESCRIPTION</u>
A72R2038	317-0154-00	RES,FXD,CMPSN:150K OHM, 5%, 0.125W

(Page 2 shows a partial view of the modified Sweep Board)

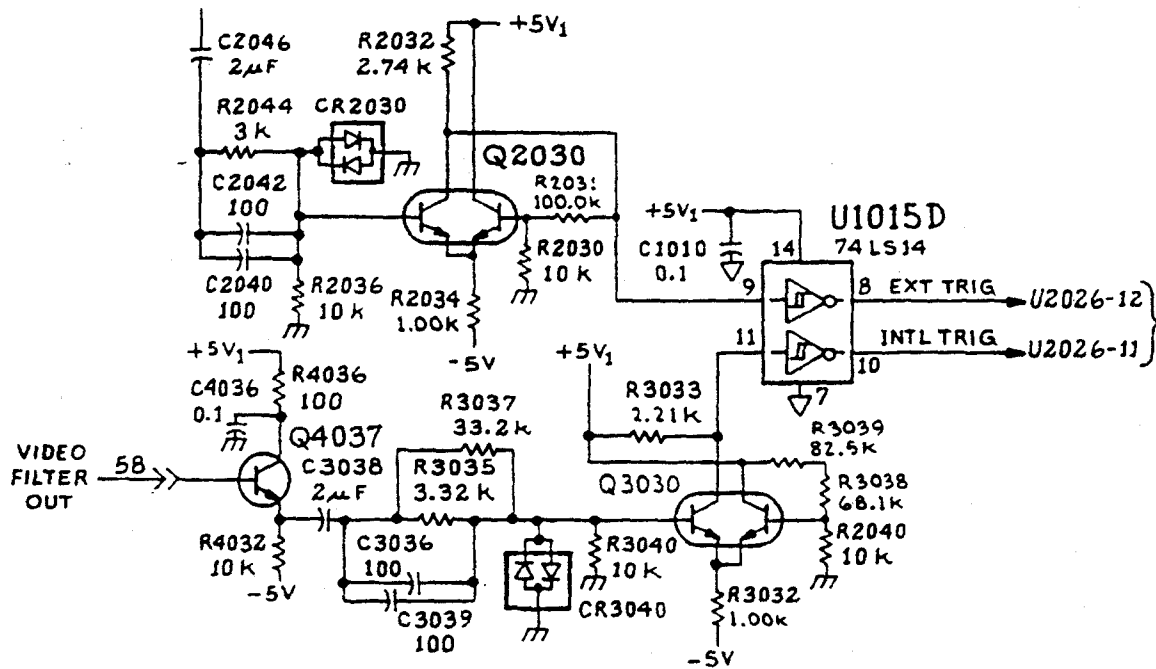

Partial Sweep board schematic showing modification

DESCRIPTION

Product Group 2E

EFFECTIVE FOR SERIAL NUMBERS:

492BP SERVICE 2	070-5566-01	B030794
492PGM SERVICE 2	070-7557-00	B010400
494AP SERVICE 2	070-5561-00	B020771
495P SERVICE 2	070-5085-00	B030835
497P SERVICE 2	070-7680-00	B020312
2753P SERVICE 2	070-6307-00	B030291
2754P SERVICE 2	070-6098-00	B030582
2755AP SERVICE 2	070-6033-01	B030251
2756P SERVICE 2	070-6319-00	B020276

Change Replaceable Electrical Parts to:**REMOVE:**

<u>CIRCUIT #</u>	<u>PART NUMBER</u>	<u>DESCRIPTION</u>
A54	671-2124-00	CIRCUIT BOARD ASSY:MEMORY
A54	671-2125-00	CIRCUIT BOARD ASSY:MEMORY (OPTION 39 ONLY)
A54C1034	290-5001-00	CAP,FXD,ELCTLT:10UF,20%,16V
A54C2030	290-5001-00	CAP,FXD,ELCTLT:10UF,20%,16V
A54C4050	290-5001-00	CAP,FXD,ELCTLT:10UF,20%,16V

ADD:

<u>CIRCUIT #</u>	<u>PART NUMBER</u>	<u>DESCRIPTION</u>
A54	671-2124-01	CIRCUIT BOARD ASSY:MEMORY
A54	671-2125-01	CIRCUIT BOARD ASSY:MEMORY (OPTION 39 ONLY)
A54C1034	290-5039-00	CAP,FXD,ELCTLT:10UF,20%,50V
A54C2030	290-5039-00	CAP,FXD,ELCTLT:10UF,20%,50V
A54C4050	290-5039-00	CAP,FXD,ELCTLT:10UF,20%,50V

<u>DESCRIPTION</u>		<u>Product Group 2E</u>
<u>Instrument</u>	<u>Manual Number</u>	<u>Starting Serial Number</u>
492BP Service 2	070-5566-01	B030784
492PGM Service 2	070-7557-00	B010375
494AP Service 2	070-5561-00	B020772
495P Service 2	070-5085-00	B030842
497P Service 2	070-7680-00	B020300
2753P Service 2	070-6307-00	B030289
2754P Service 2	070-6098-00	B030581
2755AP Service 2	070-6033-01	B030244
2756P Service 2	070-6319-00	B020276

ELECTRICAL PARTS LIST CHANGES

CHANGE TO:

<u>CIRCUIT NO.</u>	<u>PART NUMBER</u>	<u>DESCRIPTION</u>
A46	672-0165-01	CENTER FREQUENCY CONTROL BOARD WITH SHIELD
A46A1	670-9094-02	CIRCUIT BOARD ASSY:CF CONTROL
A46A1C2037	290-5039-00	CAP,FXD:10UF,20%,50V ALUMINUM
A46A1C2040	290-5039-00	CAP,FXD:10UF,20%,50V ALUMINUM
A46A1C2043	290-5039-00	CAP,FXD:10UF,20%,50V ALUMINUM
A46A1C2069	290-5039-00	CAP,FXD:10UF,20%,50V ALUMINUM
A46A1C2074	290-5039-00	CAP,FXD:10UF,20%,50V ALUMINUM
A46A1C3040	290-5039-00	CAP,FXD:10UF,20%,50V ALUMINUM
A46A1C3045	290-5039-00	CAP,FXD:10UF,20%,50V ALUMINUM
A46A1C3076	290-5039-00	CAP,FXD:10UF,20%,50V ALUMINUM

ADD:

<u>CIRCUIT NO.</u>	<u>PART NUMBER</u>	<u>DESCRIPTION</u>
A46A1TP10	214-4085-00	TERM,TEST POINT
A46A1TP11	214-4085-00	TERM,TEST POINT

(See page 2 for circuit board layout showing placement of added test points.)

Date 12-AUG-92 Change Reference: M76716

Product: See List Manual Part No.: See List

DESCRIPTION	Product Group 2E
-------------	------------------

EFFECTIVE FOR SERIAL NUMBERS:

492BP SERVICE 2	070-5566-01	B030778
492PGM SERVICE 2	070-7557-00	B010369
494AP SERVICE 2	070-5561-00	B020769
495P SERVICE 2	070-5085-00	B030842
497P SERVICE 2	070-7680-00	B020294
2753P SERVICE 2	070-6307-00	B030288
2754P SERVICE 2	070-6098-00	B030579
2755AP SERVICE 2	070-6033-01	B030245
2756P SERVICE 2	070-6319-00	B020274

Change Replaceable Electrical Parts to:

REMOVE:

<u>CIRCUIT #</u>	<u>PART NUMBER</u>	<u>DESCRIPTION</u>
A16	119-2741-01	OSCILLATOR ASSY:YIG TUNED W/CAN

ADD:

<u>CIRCUIT #</u>	<u>PART NUMBER</u>	<u>DESCRIPTION</u>
A16	119-2741-03	OSCILLATOR ASSY:YIG TUNED W/CAN

DESCRIPTION

Product Group 2E

EFFECTIVE FOR SERIAL NUMBERS:

492BP SERVICE 2	070-5566-01	B030814
492PGM SERVICE 2	070-7557-00	B010432
494AP SERVICE 2	070-5561-00	B020798
495P SERVICE 2	070-5085-00	B030859
497P SERVICE 2	070-7680-00	B020324
2753P SERVICE 2	070-6307-00	B030299
2754P SERVICE 2	070-6098-00	B030596
2755AP SERVICE 2	070-6033-01	B030253
2756P SERVICE 2	070-6319-00	B020278
2792 SERVICE 1	070-8635-00	B010141
2794 SERVICE 1	070-8636-00	B010151
2797 SERVICE 1	070-8638-00	B010119

Change Replaceable Electrical Parts to:

REMOVE:

<u>CIRCUIT #</u>	<u>PART NUMBER</u>	<u>DESCRIPTION</u>
A62	672-0187-03	LOG AMP WITH SHIELD
A62A1	670-9091-04	CKT BOARD ASSY:LOG AMP

ADD:

<u>CIRCUIT #</u>	<u>PART NUMBER</u>	<u>DESCRIPTION</u>
A62	672-0187-04	LOG AMP WITH SHIELD
A62A1	670-9091-05	CKT BOARD ASSY:LOG AMP

Date 30-NOV-92 Change Reference: M76119

Product: See List

Manual Part No.: See List

DESCRIPTION

Product Group 2E

EFFECTIVE FOR SERIAL NUMBERS:

492BP SERVICE 2	070-5566-01	B030752
492PGM SERVICE 2	070-7557-00	B010355
494AP SERVICE 2	070-5561-00	B020759
495P SERVICE 2	070-5085-00	B030834
497P SERVICE 2	070-7680-00	B020277
2755AP SERVICE 2	070-6033-01	B030243
2756P SERVICE 2	070-6319-00	B020271

Change Replaceable Electrical Parts to:

REMOVE:

<u>CIRCUIT #</u>	<u>PART NUMBER</u>	<u>DESCRIPTION</u>
A56	671-2123-00	CKT BOARD ASSY:GPIB
A56	671-0030-01	CKT BOARD ASSY:GPIB (OPTION 45 ONLY)
A56J566	131-3823-00	CONN,HDWR

ADD:

<u>CIRCUIT #</u>	<u>PART NUMBER</u>	<u>DESCRIPTION</u>
A56	671-2123-01	CKT BOARD ASSY:GPIB
A56	671-0030-02	CKT BOARD ASSY:GPIB (OPTION 45 ONLY)
A56J566	131-3361-00	CONN,HDWR

Da 30-NOV-92 Change Reference: M77545

Product: See List

Manual Part No.: See List

DESCRIPTION

Product Group 2E

EFFECTIVE FOR SERIAL NUMBERS:

492BP SERVICE 2	070-5566-01	B030811
492PGM SERVICE 2	070-7557-00	B010426
494AP SERVICE 2	070-5561-00	B020796
497P SERVICE 2	070-7680-00	B020322
2754P SERVICE 2	070-6098-00	B030593
2755AP SERVICE 2	070-6033-01	B030251
2756P SERVICE 2	070-6319-00	B020279
2792 SERVICE 1	070-8635-00	B010116
2794 SERVICE 1	070-8636-00	B010131
2797 SERVICE 1	070-8638-00	B010111

Change Replaceable Electrical Parts to:

REMOVE:

<u>CIRCUIT #</u>	<u>PART NUMBER</u>	<u>DESCRIPTION</u>
A42	672-0166-01	PRESELECTOR DRIVER WITH SHIELD
A42A1	670-5552-05	CKT BOARD ASSY:PRESELECTOR DRIVER
A42A1Q3061	151-1045-00	TRANSISTOR,SIG:JFET,P-CH;4.5V

ADD:

<u>CIRCUIT #</u>	<u>PART NUMBER</u>	<u>DESCRIPTION</u>
A42	672-0166-02	PRESELECTOR DRIVER WITH SHIELD
A42A1	670-5552-07	CKT BOARD ASSY:PRESELECTOR DRIVER
A42A1Q3061	151-1039-00	TRANSISTOR,SIG:JFET,P-CH;9V,16MA,2MS

DESCRIPTION

Product Group 2E

EFFECTIVE FOR SERIAL NUMBERS:

492BP SERVICE 2	070-5566-01	B030795
492PGM SERVICE 2	070-7557-00	B010406
494AP SERVICE 2	070-5561-00	B020785
495P SERVICE 2	070-5085-00	B030848
497P SERVICE 2	070-7680-00	B020302
2753P SERVICE 2	070-6307-00	B030292
2754P SERVICE 2	070-6098-00	B030581
2755AP SERVICE 2	070-6033-01	B030251
2756P SERVICE 2	070-6319-00	B020277

Change Replaceable Electrical Parts to:**REMOVE:**

<u>CIRCUIT #</u>	<u>PART NUMBER</u>	<u>DESCRIPTION</u>
A50	119-1992-06	PHASE LOCK MODULE
A50A2	670-9068-01	CIRCUIT BOARD ASSY:STROBE DRIVER
A50A2L1015	108-5003-00	FXD,12UH, +/- 10% Q=50 SRF 25 MHZ
A50A2L1035	108-5003-00	FXD,12UH, +/- 10% Q=50 SRF 25 MHZ

ADD:

<u>CIRCUIT #</u>	<u>PART NUMBER</u>	<u>DESCRIPTION</u>
A50	119-1992-07	PHASE LOCK MODULE
A50A2	670-9068-02	CIRCUIT BOARD ASSY:STROBE DRIVER
A50A2L1015	108-0249-00	FXD,12UH ON PWR, IRON FORM COIL
A50A2L1035	108-0249-00	FXD,12UH ON PWR, IRON FORM COIL

Date 01-JAN-93 Change Reference: M78375

Product: See List Manual Part No.: See List

DESCRIPTION

Product Group 2E

EFFECTIVE FOR SERIAL NUMBERS:

492BP SERVICE 2	070-5566-01	B030812
492PGM SERVICE 2	070-7557-00	B010431
494AP SERVICE 2	070-5561-00	B020796
495P SERVICE 2	070-5085-00	B030858
497P SERVICE 2	070-7680-00	B020322
2753P SERVICE 2	070-6307-00	B030299
2754P SERVICE 2	070-6098-00	B030594
2755AP SERVICE 2	070-6033-01	B030252
2756P SERVICE 2	070-6319-00	B020278

Change Replaceable Electrical Parts to:

REMOVE:

<u>CIRCUIT #</u>	<u>PART NUMBER</u>	<u>DESCRIPTION</u>
A28	670-7920-01	CKT BOARD ASSY:MAIN MOTHER

ADD:

<u>CIRCUIT #</u>	<u>PART NUMBER</u>	<u>DESCRIPTION</u>
A28	670-7920-02	CKT BOARD ASSY:MAIN MOTHER

A wire was connected on the bottom of the main mother board from pin 1 of the deflection amp connector to pin 16 of the Z-axis connector. The wire is then routed and taped in place as shown on page 2 of this insert.

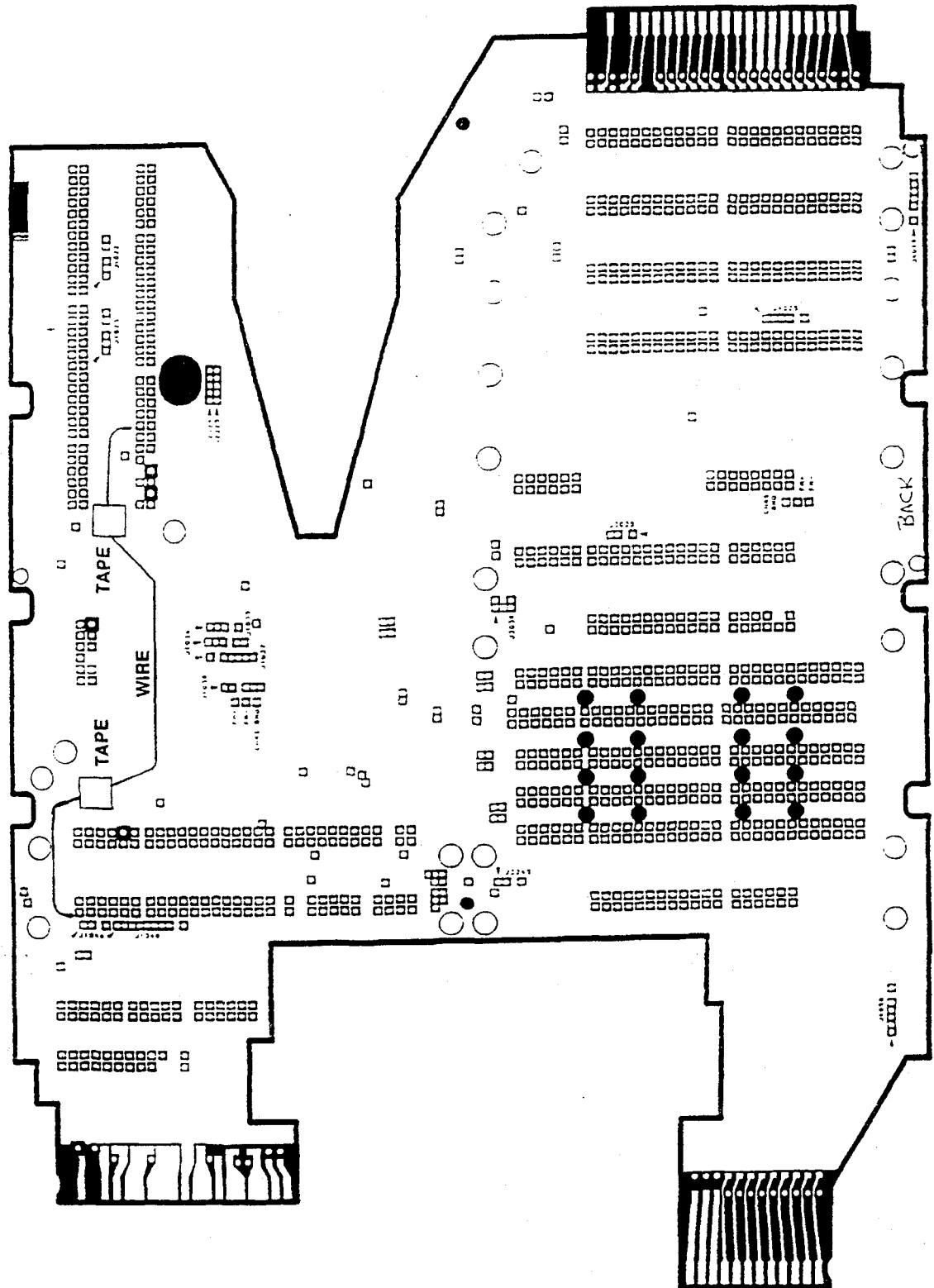

Dat 02-JAN-93 Change Reference: M78119

Product: See List

Manual Part No.: See List

DESCRIPTION

Product Group 2E

EFFECTIVE FOR SERIAL NUMBERS:

492BP SERVICE 2	070-5566-01	B030812
492PGM SERVICE 2	070-7557-00	B010431
494AP SERVICE 2	070-5561-00	B020796
495P SERVICE 2	070-5085-00	B030857
497P SERVICE 2	070-7680-00	B020322
2753P SERVICE 2	070-6307-00	B030299
2754P SERVICE 2	070-6098-00	B030594
2755AP SERVICE 2	070-6033-01	B030252
2756P SERVICE 2	070-6319-00	B020278
2792 SERVICE 1	070-8635-00	B010123
2794 SERVICE 1	070-8636-00	B010139
2795 SERVICE 1	070-8637-00	B010105
2797 SERVICE 1	070-8638-00	B010115

Replaceable Electrical Parts List Changes:

CHANGE TO:

<u>CIRCUIT #</u>	<u>PART NUMBER</u>	<u>DESCRIPTION</u>
A22	650-0736-04	PHASE LOCK ASSY (All instruments except 495P, 2753P & 2795)
A22	650-1717-03	PHASE LOCK ASSY (495P, 2753P & 2795P ONLY)
A22C220	281-0825-00	CAP,FXD,CER DI 0.005UF,+100-0%,100V
A22C221	281-0825-00	CAP,FXD,CER DI 0.005UF,+100-0%,100V
A22C222	281-0825-00	CAP,FXD,CER DI 0.005UF,+100-0%,100V
A22C223	281-0825-00	CAP,FXD,CER DI 0.005UF,+100-0%,100V
A22C224	281-0825-00	CAP,FXD,CER DI 0.005UF,+100-0%,100V
A22C226	281-0825-00	CAP,FXD,CER DI 0.005UF,+100-0%,100V
A22C227	281-0825-00	CAP,FXD,CER DI 0.005UF,+100-0%,100V

Replaceable Mechanical Parts List Changes:**CHANGE TO:**

<u>FIG. & INDEX</u>	<u>PART NUMBER</u>	<u>DESCRIPTION</u>
9-101	380-0664-01	HOUSING,2ND LO PHASELOCKED CONTROL (492BP & 2755AP ONLY)
7-68	380-0664-01	HOUSING,2ND LO PHASELOCKED CONTROL (492PGM & 2754P ONLY)
7-99	380-0664-01	HOUSING,2ND LO PHASELOCKED CONTROL (494AP & 2756P ONLY)
6-146	380-0664-01	HOUSING,2ND LO PHASELOCKED CONTROL (495P ONLY)
7-101	380-0664-01	HOUSING,2ND LO PHASELOCKED CONTROL (497P ONLY)
6-148	380-0664-01	HOUSING,2ND LO PHASELOCKED CONTROL (2753P ONLY)
20-9	380-0664-01	HOUSING,2ND LO PHASELOCKED CONTROL (2792 ONLY)
21-9	380-0664-01	HOUSING,2ND LO PHASELOCKED CONTROL (2794 ONLY)
20-9	380-0664-01	HOUSING,2ND LO PHASELOCKED CONTROL (2795 ONLY)
21-9	380-0664-01	HOUSING,2ND LO PHASELOCKED CONTROL (2797 ONLY)

Product: See ListManual Part No.: See List**DESCRIPTION**

Product Group 2E

EFFECTIVE FOR SERIAL NUMBERS:

492BP SERVICE 2	070-5566-01	B030810
492PGM SERVICE 2	070-7557-00	B010428
494AP SERVICE 2	070-5561-00	B020796
495P SERVICE 2	070-5085-00	B030858
497P SERVICE 2	070-7680-00	B020322
2753P SERVICE 2	070-6307-00	B030299
2754P SERVICE 2	070-6098-00	B030594
2755AP SERVICE 2	070-6033-01	B030252
2756P SERVICE 2	070-6319-00	B020278
2792 SERVICE 1	070-8635-00	B010121
2794 SERVICE 1	070-8636-00	B010139
2795 SERVICE 1	070-8637-00	B010105
2797 SERVICE 1	070-8638-00	B010112

Change Replaceable Electrical Parts to:**REMOVE:**

<u>CIRCUIT #</u>	<u>PART NUMBER</u>	<u>DESCRIPTION</u>
A50	119-1992-07	PHASE LOCK
A50A3	670-5522-02	CIRCUIT BOARD ASSY:OFFSET MIXER
A50A4	670-7921-03	CIRCUIT BOARD ASSY:ERROR AMPL
A50A3C2012	283-0010-00	CAP,FXD:0.05UF
A50A3C2020	283-0010-00	CAP,FXD:0.05UF
A50A3L2020	108-0226-00	COIL,RF:100UF
A50A4C2072	283-0204-00	CAP,FXD:0.01UF
A50A4R2067	315-0682-00	RESISTOR 6.8K OHM
A50A4CR3069	152-0141-02	DIODE 1N4152
A50A4VR2065	152-0175-01	DIODE,ZENER,5.6V

ADD:

<u>CIRCUIT #</u>	<u>PART NUMBER</u>	<u>DESCRIPTION</u>
A50	119-1992-08	PHASE LOCK
A50A3	670-5522-03	CIRCUIT BOARD ASSY:OFFSET MIXER
A50A4	670-7921-04	CIRCUIT BOARD ASSY:ERROR AMPL
A50A3C2012	283-0239-00	CAP,FXD:0.05UF
A50A3C2020	283-0239-00	CAP,FXD:0.05UF
A50A3L2020	108-1243-00	COIL,RF:27UF

DESCRIPTION

Product Group 2E

EFFECTIVE FOR SERIAL NUMBERS:

492BP SERVICE 2	070-5566-01	B030810
492PGM SERVICE 2	070-7557-00	B010422
494AP SERVICE 2	070-5561-00	B020787
495P SERVICE 2	070-8584-00	B031001
497P SERVICE 2	070-7680-00	B020320

Change Replaceable Electrical Parts to:

REMOVE:

<u>CIRCUIT #</u>	<u>PART NUMBER</u>	<u>DESCRIPTION</u>
A38	670-7947-03	CKT BOARD ASSY:FRONT PANEL #1
A38R6049	311-2049-00	RES,VAR NONWW:5K OHM,20%,0.5W
A38R6051	311-2050-00	RES,VAR NONWW:1K OHM,20%,0.5W
A38R1121	311-2051-00	RES,VAR NONWW:10K OHM,20%,0.5W
A38R4043	311-2051-00	RES,VAR NONWW:10K OHM,20%,0.5W
A38R4121	311-2051-00	RES,VAR NONWW:10K OHM,20%,0.5W
A38R6104	311-2052-00	RES,VAR NONWW:20K OHM,20%,0.5W
A38R6106	311-2052-00	RES,VAR NONWW:20K OHM,20%,0.5W
A38R6062	311-2054-00	RES,VAR NONWW:20K OHM,20%,0.5W

ADD:

<u>CIRCUIT #</u>	<u>PART NUMBER</u>	<u>DESCRIPTION</u>
A38	670-7947-04	CKT BOARD ASSY:FRONT PANEL #1
A38R6049	311-2049-01	RES,VAR NONWW:5K OHM,20%,0.5W
A38R6051	311-2050-01	RES,VAR NONWW:1K OHM,20%,0.5W
A38R1121	311-2051-01	RES,VAR NONWW:10K OHM,20%,0.5W
A38R4043	311-2051-01	RES,VAR NONWW:10K OHM,20%,0.5W
A38R4121	311-2051-01	RES,VAR NONWW:10K OHM,20%,0.5W
A38R6104	311-2052-01	RES,VAR NONWW:20K OHM,20%,0.5W
A38R6106	311-2052-01	RES,VAR NONWW:20K OHM,20%,0.5W
A38R6062	311-2054-01	RES,VAR NONWW:20K OHM,20%,0.5W

DESCRIPTION

Product Group 2E

EFFECTIVE FOR SERIAL NUMBERS:

492BP SERVICE 2	070-5566-01	B030810
494AP SERVICE 2	070-5561-00	B020787
495P SERVICE 2	070-8584-00	B030852
2753P SERVICE 2	070-6307-00	B030298
2755AP SERVICE 2	070-6033-01	B030251
2756P SERVICE 2	070-6319-00	B020278
2792 SERVICE 1	070-8635-00	B010100
2794 SERVICE 1	070-8636-00	B010100
2795 SERVICE 1	070-8637-00	B010100
2797 SERVICE 1	070-8638-00	B010100

Change Replaceable Electrical Parts to:**REMOVE:**

<u>CIRCUIT #</u>	<u>PART NUMBER</u>	<u>DESCRIPTION</u>
A19	119-1845-03	110 MHZ IF ASSY

ADD:

<u>CIRCUIT #</u>	<u>PART NUMBER</u>	<u>DESCRIPTION</u>
A19	119-1845-04	110 MHZ IF ASSY