

User Manual



packetBERT 200 DC-200 Mb/s Bit Error Rate Tester

070-9396-01

This document applies to firmware version 2.0 and above.

Copyright © Tektronix, Inc. 1998. All rights reserved.

Tektronix products are covered by U.S. and foreign patents, issued and pending. Information in this publication supersedes that in all previously published material. Specifications and price change privileges reserved.

Printed in the U.S.A.

Tektronix, Inc., P.O. Box 1000, Wilsonville, OR 97070-1000

TEKTRONIX and TEK are registered trademarks of Tektronix, Inc.

WARRANTY

Tektronix warrants that this product will be free from defects in materials and workmanship for a period of one (1) year from the date of shipment. If any such product proves defective during this warranty period, Tektronix, at its option, either will repair the defective product without charge for parts and labor, or will provide a replacement in exchange for the defective product.

In order to obtain service under this warranty, Customer must notify Tektronix of the defect before the expiration of the warranty period and make suitable arrangements for the performance of service. Customer shall be responsible for packaging and shipping the defective product to the service center designated by Tektronix, with shipping charges prepaid. Tektronix shall pay for the return of the product to Customer if the shipment is to a location within the country in which Tektronix service center is located. Customer shall be responsible for paying all shipping charges, duties, taxes, and any other charges for products returned to any other locations.

This warranty shall not apply to any defect, failure or damage caused by improper use or improper or inadequate maintenance and care. Tektronix shall not be obligated to furnish service under warranty a) to repair damage resulting from attempts by personnel other than Tektronix representatives to install, repair or service the product; b) to repair damage resulting from improper user or connection to incompatible equipment; or c) to service a product that has been modified or integrated with other products when the effect of such modification or integration increases the time or difficulty of servicing the product.

THIS WARRANTY IS GIVEN BY TEKTRONIX WITH RESPECT TO THIS PRODUCT IN LIEU OF ANY OTHER WARRANTIES, EXPRESSED OR IMPLIED. TEKTRONIX AND ITS VENDORS DISCLAIM ANY IMPLIED WARRANTIES OF MERCHANTABILITY OR FITNESS FOR A PARTICULAR PURPOSE. TEKTRONIX' RESPONSIBILITY TO REPAIR OR REPLACE DEFECTIVE PRODUCTS IS THE SOLE AND EXCLUSIVE REMEDY PROVIDED TO THE CUSTOMER FOR BREACH OF THIS WARRANTY. TEKTRONIX AND ITS VENDORS WILL NOT BE LIABLE FOR ANY INDIRECT, SPECIAL, INCIDENTAL, OR CONSEQUENTIAL DAMAGES IRRESPECTIVE OF WHETHER TEKTRONIX OR THE VENDOR HAS ADVANCE NOTICE OF THE POSSIBILITY OF SUCH DAMAGES.

How to Reach Customer Service

If you have any questions regarding the operation, maintenance, repair, or application of your Tektronix equipment, contact your local sales and service office. For a complete list of the Worldwide Sales and Service Offices contact (800) 426-2200.

Tektronix provides high quality Technical Support on applications, operation, measurement specifications, hardware, and software by expert application engineers. For Applications Support, call the Customer Support Center listed below.

Mailing Address	Tektronix, Inc. Measurement Business Division P.O. Box 500 Beaverton, Oregon 97077-0001 USA	Attn. Customer Service
Customer and Sales Support Center	800-TEK-WIDE or 800-835-9433 Ext 2400	Hours are 6:00 AM to 5:00 PM, Pacific Time. After hours Voice Mail is available.
Direct	503-627-2400	
Fax	503-627-5695	
E-Mail	tm_app_supp@tek.com	
Web Site	http://www.tek.com	

U.S.A., Africa, Asia, Australia, Central & South America, Japan

Tektronix, Inc.

P.O. Box 500

Beaverton, Oregon 97077-0001

For additional literature, or the address and phone number of the Tektronix Sales Office or Representative nearest you, contact: (800) 426-2200

Belgium: Brussels

Phone: 32(2) 725 96 10

Fax: 32(2) 725 99 53

Canada: Calgary

Phone: (403) 274-2691

Fax: (403) 274-3483

Denmark: Copenhagen

Phone: 45 44 850 700

Fax: 45 44 850 701

Eastern Europe, Middle East and Austria

Tektronix Ges.m.b.H

Triester Strasse 14

A-2351 Wiener Neudorf, Austria

Phone: ++43 (2236) 8092-0

Fax: ++43 (2236) 8092-200

Finland: Helsinki

Phone: 358 4783 400

Fax: 358 47834 200

France and North Africa

Tektronix S.A.

ZAC Courtaboeuf, 4 Av du Canada, B.P.13

91941 Les Ulis Cedex, France

Phone: 33(1) 69 86 81 81

Fax: 33(1) 69 07 09 37

Germany: Cologne

Phone: 49(221) 94770

Fax: 49(221) 9477 200

Italy: Milan

Phone: 39(2) 25 0861

Fax: 39(2) 25 086 400

Japan: Tokyo

Phone: 81(3) 3448-3111

Fax: 81(3) 3444-3661

The Netherlands: Hoofddorp

Phone: 31(23) 069 5555

Fax: 31(23) 569 5500

Norway: Oslo

Phone: 47(22) 07 0700

Fax: 47(22) 07 0707

Spain: Madrid

Phone: 34(1) 372 6000

Fax: 34(1) 372 6049

Sweden: Stockholm

Phone: 46(8) 629 6500

Fax: 46(8) 629 6540

Switzerland: Zug

Phone: 41(42) 219192

Fax: 41(42) 217784

U.K.: Marlow

Phone: 44 1628 403300

Fax: 44 1628 403301

Tektronix sales and service offices around the world:

Algeria,
Argentina, Australia,
Bahrain, Bangladesh, Belgium,
Bolivia,
Brazil,
Bulgaria,
Canada,
Chile,
People's Republic
of China, Columbia,
Costa Rica, Cypress,
Czechoslovakia, Denmark,
Ecuador,
Egypt,
Finland,
France,
Germany,
Greece,
Hong Kong, Iceland,
India,
Indonesia,
Ireland,
Israel,
Italy,
Ivory Coast,
Japan,
Jordan,
Korea,
Kuwait,
Lebanon, Malaysia,
Mexico,
The Netherlands, New Zealand,
Nigeria,
Norway,
Oman,
Pakistan,
Panama,
Peru,
Phillippines, Poland,
Portugal,
Saudi Arabia, South Africa,
Singapore,
Spain,
Sri Lanka,
Sweden, Switzerland, Taiwan,
Thailand,
Tunisia,
Turkey,
United Arab Emirates,
United Kingdom,
Uruguay,
Venezuela,
Zimbabwe

Table Of Contents

Customer Service, how to reach	iv
General Safety Summary	xi
Getting Started	1-1
Product Description	1-2
Overview	1-4
Features & Capabilities	1-5
Applications	1-5
Accessories	1-6
What is a "Packet" Bit Error Rate Tester?	1-6
Gap Clock	1-8
Signal Analysis	1-8
EYE WIDTH Measurements	1-8
Interfaces	1-9
First Time Operation	1-10
Power On/Default	1-10
Connect the Generator BNC to the Analyzer BNC	1-11
Terminate Unused Generator Outputs	1-11
Clear the Analyzer History Status	1-11
Inject an Error	1-12
Clear the Errors	1-12
Change the Generator Frequency	1-12
Change the Generator Data Amplitude	1-13
Change the Analyzer Data Input Threshold	1-13
Change the Data Pattern	1-14
Setup for Mixed Mode Operation	1-15
Download a Pattern from Diskette	1-16
Load a Mixed Mode Pattern from Floppy Disk	1-17
Other Examples of Pattern and Setup Files	1-19
Operating Basics	2-1
Functional Description of PB200	2-2
BERT Technology	2-2
PB200 Pattern Generator	2-3
Error Injection	2-5
Output Amplifiers	2-5
Internal Clock Source	2-7
PB200 Clock Gap	2-8
PB200 Continuous/Start Mode	2-9
Synchronization, Startup and Propagation Delay	2-10
How does PB200 synchronize to an incoming pattern?	2-10
Example of Sync Operation with Straight PRBS data	2-12
Analyzer Inputs	2-13
Reference Pattern Generator	2-14
Synchronization	2-14
SLIP Enable/Disable	2-14
No Synchronization Required	2-15

Auto Search.....	2-15
Error, Frequency Measurements	2-16
Frequency.....	2-16
Total.....	2-16
Error Rate.....	2-16
Simultaneous Measurements.....	2-16
Error Field.....	2-17
BER Eye Width Measurement	2-18
Phase Mode	2-18
BER Mode.....	2-19
Extrapolate "ON"	2-19
PB200 Error Rates.....	2-20
Controls, Indicators and Connectors	2-21
Entry Keys.....	2-22
Power Switch.....	2-22
UTILITY	2-22
Print	2-23
Left Display Control	2-23
Right Display Control.....	2-24
Factory Default.....	2-25
RS-232	2-25
GPIB	2-26
Remote	2-26
More.....	2-26
Time Date	2-27
Monitor	2-27
Contrast.....	2-27
PATTERN.....	2-28
Analyzer	2-29
Floppy Drive.....	2-29
Rear Panel	2-30
Changing the Line Fuse.....	2-32
AC Line.....	2-33
Rear Panel BNCs	2-34
Reference.....	3-1
Menus and Displays	3-2
Generator Soft Keys.....	3-3
Clock Frequency	3-3
Clock Output	3-4
Data Output	3-5
Ext Clock.....	3-6
Data Pattern.....	3-7
More.....	3-9
SYNC.....	3-9
Error Control	3-10
Pattern Edit	3-11
Pattern Copy	3-13

Analyzer Soft Keys.....	3-14
Slip Control.....	3-14
Auto Search.....	3-14
Eye Width.....	3-14
Clock Input.....	3-15
Data Input.....	3-15
Data Pattern.....	3-18
Auto Search.....	3-21
More.....	3-25
Eye Width.....	3-26
Error Mode.....	3-28
Pattern Edit.....	3-29
Pattern Copy.....	3-32
Sliding Window.....	3-33
Test Control.....	3-34
Test Results.....	3-35
Menu Maps.....	3-36
Applications.....	3-37
PB200 Satellite Test & Simulation.....	3-37
Basic BERT Testing with the PB200.....	3-38
Mixed Mode Patterns with the PB200.....	3-43

Appendices

Specifications - PB200.....	Appendix-2
System Performance Verification.....	Appendix-5
Loading and Storing Pattern Files.....	Appendix-9
PRBS Patterns.....	Appendix-15
Diskette File Format.....	Appendix-16
Pattern Editor Requirements & Features.....	Appendix-19
Default Factory Settings.....	Appendix-29
Reports.....	Appendix-34
Cleaning Instructions.....	Appendix-37
Glossary.....	Appendix-38
Index.....	Appendix-41

List of Figures

Figure 1-1. Front Panel - PB200	1-3
Figure 1-2. Rear Panel - PB200	1-3
Figure 1-3. Structure of a Mixed Mode Pattern	1-6
Figure 1-4. Simplified Pattern Generator Memories	1-7
Figure 1-5. Simple Packet Structure.....	1-7
Figure 1-6. Simplified Clock Source Diagram.....	1-8
Figure 1-7. Typical Front Panel Display	1-10
Figure 2-1. Pattern Generator Block Diagram	2-3
Figure 2-2. Example of MIXED Pattern.....	2-4
Figure 2-3. Model of Output Amplifier	2-6
Figure 2-4. Block Diagram - PB200 Clock Input	2-8
Figure 2-5. Example of Gated Clock	2-8
Figure 2-6. Simplified Flow chart for Clock Slip Synchronization.....	2-10
Figure 2-7. Front Panel - PB200	2-21
Figure 2-8. Rear Panel - PB200	2-30
Figure 3-1. Example of Front Panel Display	3-2
Figure 3-2. Example of Editing Pattern Payload.....	3-12
Figure 3-3. Extrapolated Eye Measurement.....	3-27
Figure 3-4. Example of Editing Pattern Payload.....	3-30

General Safety Summary

Review the following safety precautions to avoid injury and prevent damage to this product or any equipment connected to it.

Only qualified personnel should perform maintenance and service procedures on the PB200.

Safety Instructions



WARNING! Read and Follow all of these Safety Instructions.

Failure to do so can cause injury to the user and damage the instrument.

AC Power

The instrument is designed to be powered from 90-125 or 220-240 VAC; 300 VA max. Voltage switching is automatic. There is no voltage switch.

Ground the Instrument

The PB200 is grounded through its AC power cord. Plug this power cord only into a properly grounded, three-conductor outlet. If you operate the instrument without a proper ground, then should there be a fault in the instrument, there is a potential that all metal surfaces on the instrument can become a potential shock hazard.

Use the Proper Fuse

Operating the instrument with an improper fuse creates a fire hazard. The correct fuses to install in the PB200 are shown below:

Power Voltage	Range	Max Power	Fuse Type
115 VAC	90-132V	300W	5 AT, 250 VAC
230 VAC	180-250V	300W	2.5 AT, 250 VAC

"T" indicates a Slo-blo fuse.

Do Not Operate in an Explosive Atmosphere



The PB200 does not provide protection from static discharges or arcing components and therefore must not be operated in an explosive atmosphere.

Do Not Remove Instrument Covers

To avoid a shock hazard and to maintain proper air flow, never operate the PB200 with any of its outside covers removed. There is a plastic front cover that protects the front panel while the test equipment is not in use. This plastic cover must be removed in order to access the controls on the front panel of the PB200.

Safety Terms and Symbols

Paragraphs or sections in this document that contain important safety information will be identified by either a WARNING or a CAUTION label in the left hand margin. These labels are explained below:

Icon	Label	Meaning
	WARNING!	Indicates a safety practice that must be followed to avoid possible injury to the user and possible damage to the instrument.
	CAUTION!	Indicates a safety practice that must be followed to prevent possible damage to the PB200 or other instruments used with the PB200.

Product Labels

These terms may appear on the product:

A yellow label indicates DANGER of an injury hazard immediately accessible as you read the marking.

A WARNING label indicates an injury hazard not immediately accessible as you read the marking.

CAUTION: indicates a hazard to propriety including the product.

Product Symbols

The following symbols may appear on the product:

YELLOW
LABEL

Indicates
DANGER



Indicates
ATTENTION
Refer to Manual

Preface

This manual describes how to use the Tektronix PB200 Test Set. The product is also known by the name, packetBERT 200. This manual is your primary source of information on how to use the PB200 functions.

How This Manual is Organized

This manual is divided into four sections: *Getting Started*, *Operating Basics*, *Reference*, and *Appendices*.

Getting Started provides an overview of the PB200 and describes first time operation.

Operating Basics describes the hardware controls, indicators, connectors, and display elements for Tx, Rx and the cabling required.

Reference describes the LCD Menus and Screens. It also provides a representative sample of Applications.

The *Appendices* provide a listing of specifications, default factory settings, system performance verification and other useful information.

Conventions

This manual uses the following conventions:

- The names of front-panel controls and menus appear in all upper case letters, for example, TRANSMIT and HELP.
- Names appear in the same case in this manual as they appear on the display screens of the PB200.
- Within a procedure, a specific button to be pressed or a parameter to be selected appears in **boldface** print.

Some procedures require several iterations of highlighting parameters and selecting choices. Some procedures may require more than one menu button or menu page selection as well.

Related Manuals

The following document is also available for the PB200:

- The *PB200 BER Tester Programmer Manual* (Tektronix part number 070-9966-xx) describes how to control the PB200 using an instrument controller.

Certifications and Compliances

CSA Certified Power Cords

CSA Certification includes the products and power cords appropriate for use in the North America power network. All other power cords supplied are approved for the country of use.

Getting Started

Getting Started

This chapter describes the PB200 200 Mb/s Bit Error Rate Transceiver and provides a list of standard and optional accessories.

The PB200 is a compact and portable tester, with Tx and Rx in one box.

In addition, this section explains how to operate the PB200 for the first time, and how to verify that the PB200 is operating properly.

Product Description

Overview

The PB200 is a versatile general purpose bit error rate tester (BERT). It contains both a generator (Tx) and analyzer (Rx) in one portable instrument, and operates at bit rates from DC up to 200 Mb/s. It can function as a fully-featured non-packetized BERT (like the GB700 and GB1400) by generating and analyzing continuous PRBS, Mark Density, or fixed word patterns.

As a general purpose BERT, the PB200 is has several important features:

1. Data and clock outputs are programmable for both output amplitude and offset. This simplifies interfacing with a wide variety of logic levels including ECL, PECL, and TTL;
2. Input and output data edges can be delayed with 20 pS time resolution. This provides increased capabilities to de-skew signals in Automatic Test Equipment (ATE) systems, align data for BER measurements, and characterize setup and hold timing specifications;
3. Auto Search Synchronization to locate the best clock and data thresholds, delay timing, data polarity, and PRBS pattern type up to $2^{15}-1$.

The PB200 is also bit error rate tester with unique features not found in traditional BERTs. Programmable word memories, up to 256 Kbits in length, allow the construction of a packet or cell than can consist of user-definable preamble, overhead and data.

Data communications has historically used data groups, such as the type of data structures specified in the RS-232 standard. In RS-232 transmissions, ASCII characters are embedded in data groups of 10 or 11 bits. They are arriving at a known data rate but are separated from each other in time. Today's packet structures are much longer and more complex, in many cases consisting of data groups thousands of bits long. The PB200 is able to generate and process defined time gaps between data packets (known as clock gap or burst operation), and mask off bits which have been programmed as "header", "framing" or "preamble" bits from the error calculation.

The combination of flexible pattern generation, pattern analysis, and clock gapping features make the PB200 extremely versatile. It can be adapted to a variety of standard applications and is particularly suited for environments where data structures are packetized. The latter capability enables the PB200 to generate and analyze formatted NRZ data such as TDMA, ATM cells, MPEG2 streams, basic Fibre Channel data frames, and Ethernet packet data. The PB200 is not able to replace a protocol analyzer in these environments, but can go a long way in testing digital transmission error rates in these applications.

The PB200 is focused on the research, design, and manufacturing of telecommunication components, modules, or links operating at data rates to 200Mb/s.

Front and rear panel views of the PB200 are shown below.

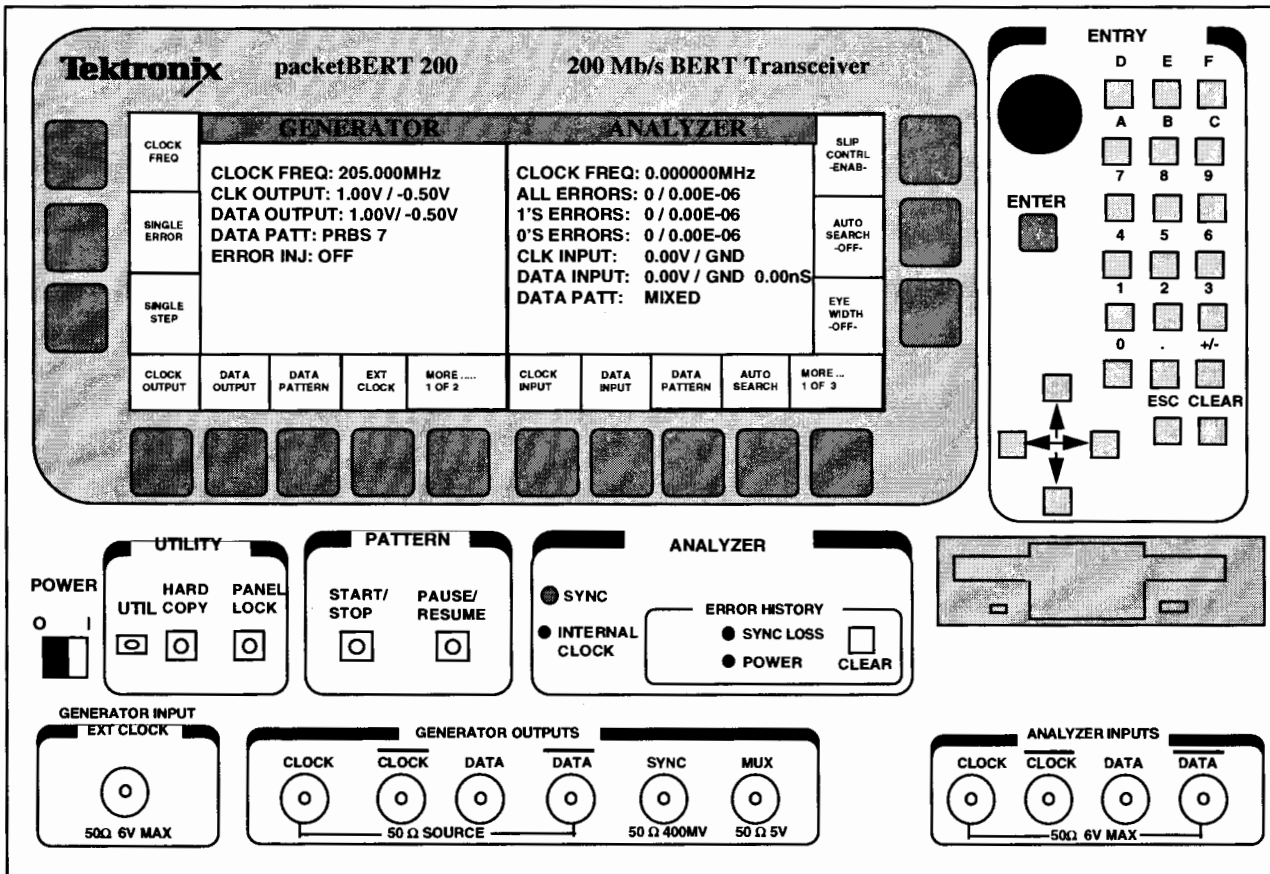

Figure 1-1. Front Panel - PB200

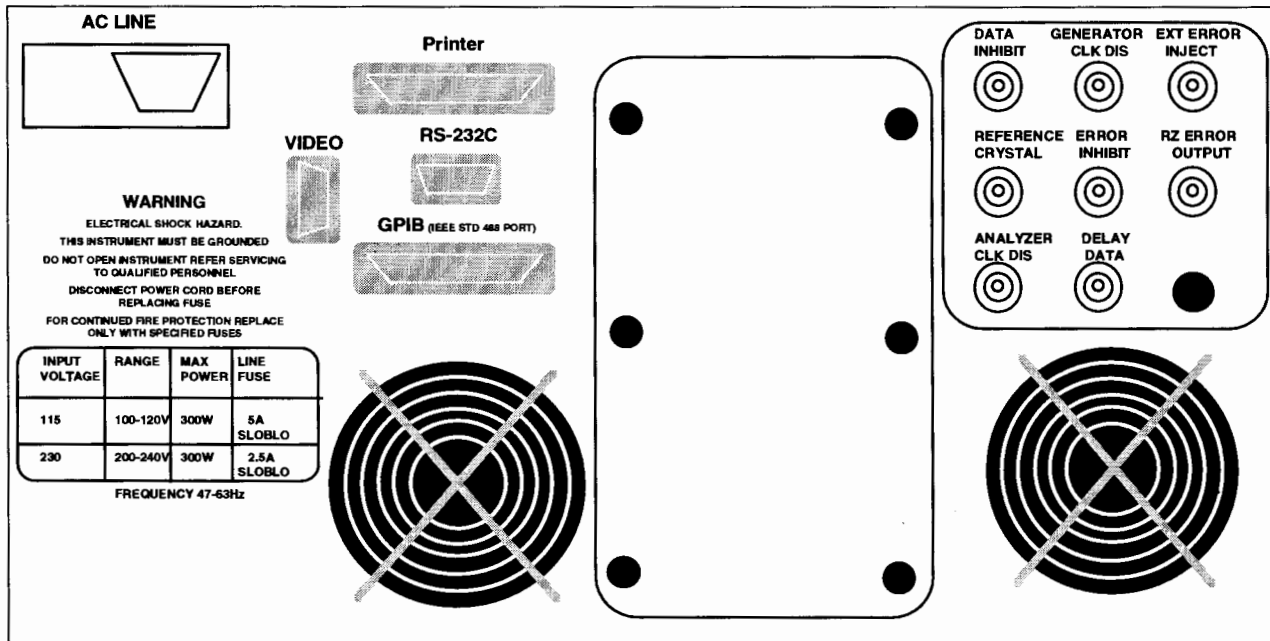

Figure 1- 2. Rear Panel - PB200

Features & Capabilities

- Operation from DC to 200 MHz
- Internal PLL Synchronized Clock Source programmable in 1 Hz steps.
- Framed Packets or Plain BERT
- PRBS, Mark Density and User-defined Patterns
- PRBS 2^n-1 : n = 7, 9, 10, 11, 15, 23, 31
- 256 Kbit memories for user-definable packets or words
- Symmetrical, low-jitter output waveforms
- Variable Data/Clock Amplitude and Offset to support ECL, PECL, and TTL
- Clock/Data Delay up to 32 nS in 20 pS increments - This provides increased capabilities to de-skew signals, align data for BER measurements, and characterize timing specifications
- Controllable Gapped Tx Clock for Burst Mode Applications - provides capabilities to generate a gapped clock from memory in the generator and analyze data from an external non-continuous clock.
- Burst mode operation for BER measurements with non-continuous clocks - provides capabilities to generate a gapped clock from memory in the generator and analyze data from an external non-continuous clock.
- Phase synchronous clock and data edge tracking - this maintains constant phase relationship between clock and data regardless of the operating frequency. This eliminates the need for clock and data re-timing and can save time when testing BER at multiple frequencies.
- Auto Search and Auto Sync capabilities for easy setup - automatically synchronizes to the incoming signals by adjusting thresholds, delays, polarity, and PRBS patterns up to $2^{15}-1$
- Automatic Eye Width Measurements
- Powerful analysis and reporting functions. These include Window Bit Error Rate (**BER**), Errored Seconds (**ES**), Severely Errored Seconds (**SES**), Degraded Minutes (**DM**), Unavailable Seconds (**US**), and Loss of Signal (**LOS**).
- Internal hard drive and built-in 3.5" disk drive for software upgrades, test data storage and instrument setup storage

Applications

- Data link production test
- TDMA transceiver development
- Satellite and cable modem development
- Wireless LAN Development (typical rates up to 20 Mb/s).
- Development of Digital Subscriber Loop interfaces, e.g., ADSL (7 Mb/s)
- LAN and WAN sub-system development
- Satellite system testing
- Development of Fast Ethernet at 125 Mb/s
- MPEG 2 testing using mixed mode patterns

Accessories

Standard accessories are included with the PB200 DC-200 Mb/s Bit Error Rate Tester. If you wish to purchase optional accessories or additional standard accessories, see the Tektronix products catalog or contact your local Tektronix field representative.

Standard Accessories

- Power cable, Tektronix part number.
- PB200 DC-200 Mb/s BER Tester User Manual, Tektronix part number 070-9396-01
- PB200 DC-200 Mb/s BER Tester Programmer Manual, Tektronix part number 070-9966-xx
- Sample Pattern Disk
- Pattern Editing software
- Instrument Front Cover

Optional Accessories

- Rackmount. Tektronix part number 016-1464-01
- Transit case, Tektronix part number 016-1447-00
- BNC, 50 Ohm cable, 24-feet, Tektronix part number 012-1339-00

What is a "Packet" Bit Error Rate Tester?

In addition to PRBS data, the PB200 has features for generating and analyzing "packetized" information including data packets, frames, and cells. A packet is typically a block of digital information addressed to specific user(s) on a network, a frame is typically a fixed or variable length unit that carries packets over one data link, and a cell is typically a fixed-length unit, commonly 53 bytes, that carries segmented frames or packets.

Packet structures are useful with modem development, satellite data links, ATM traffic simulation, PCM control systems, and MPEG subsystems. BERT Applications include communication links, subsystems and components that require a unique frame or packet structure.

A typical packet structure is shown in Figure 1-3. It consists of some number of bits containing header or overhead information, and some number of bits as payload.

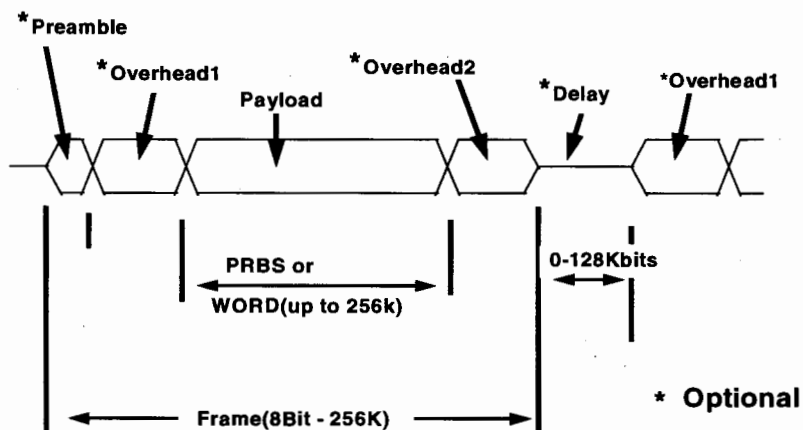
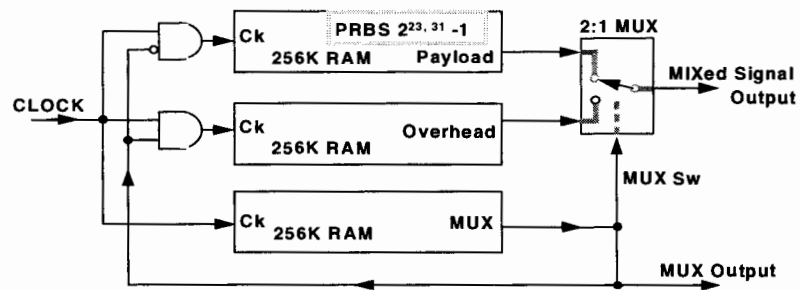

Figure 1-3. Structure of a Mixed Mode Pattern

Features useful for packet data include programmable preamble, overhead, payload, and packet delay. A preamble is a fixed length of bits that is transmitted one time, and only one time, at the very start of a test. Preambles are sometimes used to transmit a unique bit pattern to a device under test as some form of "wake up" pattern. Other uses include the transmission of some unique address for wireless and satellite applications.

The PB200 derives its "packet" capabilities from three internal Random Access Memories. The three memories are known as the *payload*, *overhead*, and *mux*. Unique data patterns can be loaded into the *payload* and *overhead* memories while the third memory, *mux*, controls the switching between the payload and overhead memories. A simplified view of the PB200 pattern memories is shown in Figure 1-4.



Generator and Analyzer circuits are identical but independent

Figure 1-4. Simplified pattern generator memories

The *payload* ram is where a user would typically store the data that will be used to simulate transmitted data. It's design also includes a PRBS generator for long length data patterns. The *overhead* ram is where the user would typically store the data used for protocol and other framing information. The *mux* ram is where the user stores the control information for switching between payload and overhead.

For example, suppose the user wants to generate an overhead word of '0001' (binary) followed by 6 bits of pseudo random data to represent payload. This type of packet structure is shown in Figure 1-5.

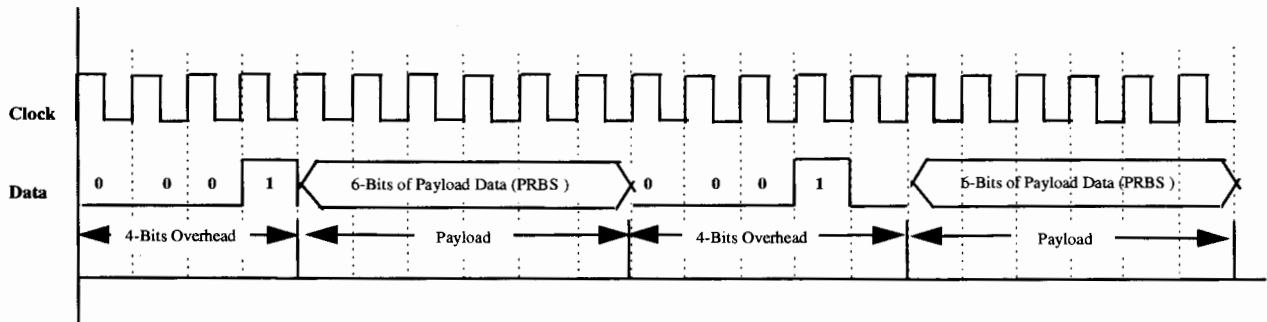

Figure 1-5. Simple Packet Structure

For each succeeding cycle, the user wants to switch between the fixed overhead data of '0001' and then six bits of payload data. The mux pattern to switch between the overhead and payload memories would look like:

```
1111000000111100000011110000001111000000...etc. up to 256K bits.
```

Each time the MUX bit is logical 1, the data bit will be taken from the overhead memory and the overhead bits '0001' will be output. Each time the MUX bit is a logical 0, the data bit comes from the payload memory and the PB200 outputs 6 bits of payload data. This example MUX word will alternate between 4 bits of overhead data and 6 bits of payload data.

Gap Clock

The PB200 will operate from an internal or external clock source. When running with the internal synthesized clock source, an external 10 MHz reference can also be selected to phase-lock the internal clock generator. A simplified view of the PB200 clock is shown in Figure 1-6.

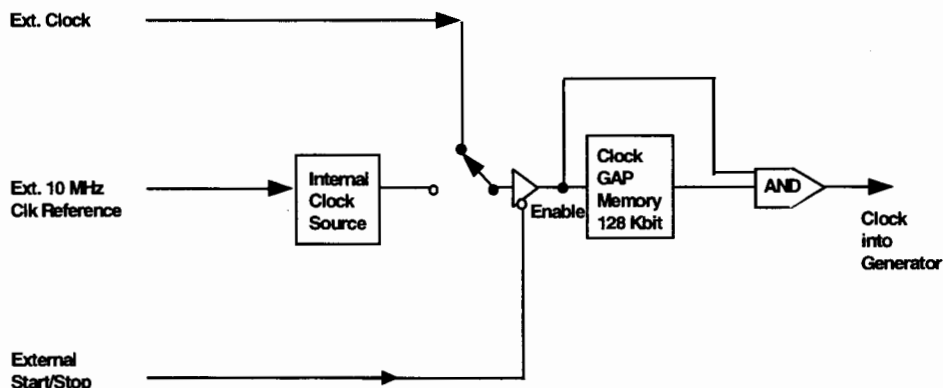

Figure 1-6. Simplified clock source diagram

Clock sources are selectable from the front panel or via software. A unique feature is the ability to generate burst data. The output from the internally synthesized clock or the external clock input can be gapped. Clock gapping is performed by locally ANDing the clock and the output from a programmable memory. When the GAP memory is filled with logical 1s, the clock operation will be continuous. When filled with 0s, the clock operation will pause. Using the 128 Kbit gap memory array, it is an easy process to control the "on" and "off" bursting of the clock. An external Clock Disable is also provided for external synchronization of PB200 data output.

Signal Analysis

For complete flexibility in signal analysis, the PB200 allows BER analysis on all, or only part of the received digital information. Analysis can be performed on only the overhead, only the data, or both overhead and data at the user's selection.

EYE-WIDTH Measurements

The receiver can automatically measure "eye-width" at user-selectable BERs, and extrapolate eye-widths at very low BERs from data accumulated over much shorter elapsed times than normally required. The transmitter can also generate a gapped clock. The BER eye-width is the width of the data bits that are either at or below a specified bit error rate. There are three modes of eye-width operation: Phase, BER, and Extrapolate.

Interfaces

The instrument includes a high resolution LCD display for the user interface, which features softkeys and pop-up menus. The 3.5" MS-DOS compatible floppy disk drive can be used to store test results, save test setups and transfer test data to a personal computer for further analysis. Also included are RS-232 and GPIB interfaces, which can be used for downloading test data or automated remote control.

Instrument Connections and Controls

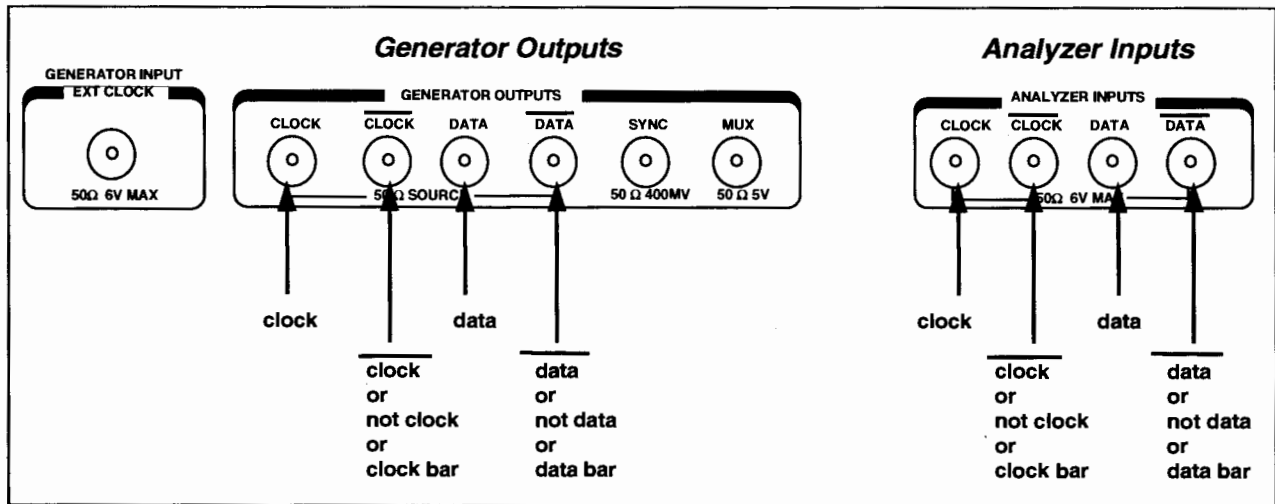

First Time Operation

This section is intended as a quick method of getting familiar with the PB200. Examples of commonly changed parameters such as OUTPUT AMPLITUDE, INPUT THRESHOLD, and DATA PATTERNS are given.

Power On/Default

When the unit is received from the factory, it will be set to the factory default condition.

The two LED lights for Internal Clock and Power Loss, on the front panel, should appear yellow for Internal Clock and red for Power Loss.

	GENERATOR					ANALYZER					
CLOCK FREQ	CLOCK FREQ: 205.00000 MHz					CLOCK FREQ: 0.00000 MHz					SLIP CNTRL ENAB
SINGLE ERROR	CLK OUTPUT: 1.00V / -0.50V					ALL ERRORS: 0/0.00E-06					AUTO SEARCH OFF
	DATA OUTPUT: 1.00V / -0.50V					1'S ERRORS: 0/0.00E-06					
	DATA PATT: PRBS 7					0'S ERRORS: 0/0.00E-06					
SINGLE STEP	ERROR INJ: OFF					CLK INPUT: 0.00V/GND					EYE WIDTH OFF
						DATA INPUT: 0.00V/GND/0.00nS					
CLOCK OUTPUT	DATA OUTPUT	DATA PATTERN	EXT CLOCK	MORE 1 OF 2	CLOCK INPUT	DATA INPUT	DATA PATTERN	AUTO SEARCH	MORE 1 of 3		

Figure 1-7. Typical front panel display.

If the front panel does not look like this, the unit should be reset to the default settings. *Note: Resetting the unit to factory defaults is used infrequently. It helps simplify instructions for First Time users. An experienced user would not need to perform this step.*

To set to the factory default:

1. Press the key UTILITY. This will bring up the Utility submenu.
2. Press the soft key FACTORY DEFAULT.
3. Press the key ENTER.
4. Press the down arrow key so that YES is in reverse video. *down arrow*
5. Press the key ENTER to perform the default reset.
6. Press the key UTILITY to remove the utility submenu.

The front panel should now look as shown above.

Connect the Generator BNC output "DATA" to the Analyzer BNC input "DATA".

Use 50 Ohm coaxial cable with a length of 24" +/- 6".

Terminate Unused Generator Outputs

Terminate the unused "NOT DATA" and "NOT CLOCK" outputs of the Generator. Use any 50 Ohm BNC terminator such as an Amphenol #46650-51 or equivalent.

Clear the Analyzer History status (Error History LEDs for Power loss, Sync loss, Bit error, and Phase error)

1. Push the key "CLEAR".

The Power loss LED will go OFF.

2. Start the Generator

Push the key "START/STOP".

The LED inside the START/STOP key will light, and the PB200 Analyzer display will change to the following:

Analyzer:	CLOCK FREQ:	205.0000 MHz (± 100 ppm)
	ALL ERRORS:	0 / 0.00E-8
	1'S ERRORS:	0 / 0.00E-8
	0'S ERRORS:	0 / 0.00E-8
	CLK INPUT:	0.00V / GND
	DATA INPUT:	0.00V / GND / 0.00nS
	DATA PATT:	PRBS 7

The green LED inside the START/STOP key indicates that the Generator is running. The Analyzer is now actively measuring the clock frequency, and the error rate.

Inject an Error

1. Press the soft key on the Generator side of the display "Single Error".

This will inject one error into the Generator Data output. The Analyzer display "Errors" will count one, and the "Errors" error rate will change to some value other than 0. The rate depends on how many bits have passed since the Generator was started.

Either the 1's or 0's error display will also have counted the injected error. This depends on whether the error was injected on an outgoing one or zero in the data pattern.

Clear the Errors

1. Press the key "CLEAR".

All Error counters and rates will return to 0 and remain there. Also, the error history LEDs will be cleared.

Change the Generator Frequency

1. Press the soft key "CLOCK FREQ".

A pop-up window will appear, indicating the frequency that the Generator is currently set to.

To incrementally change the frequency.

2. Use the left/right keys to select the resolution.
3. Turn the front panel knob clockwise to increase, or counter clockwise to decrease the clock frequency.

Alternately, to change to a new value.

4. Enter the most significant digit of the new value to be entered, followed by the remaining digits. The value must be entered in MHz.
5. Press the "enter" key to effect the change.
6. Press the soft key "CLOCK FREQ" or the "ESC" to remove the pop-up window.

Change the Generator Data Amplitude

1. Press the soft key "DATA OUTPUT"

A pop-up window will appear:

DATA AMPL	1.00 V
DATA OFFSET	-.50 V
OUTPUT DELAY	0.00 nS
POLARITY	NORMAL

2. Using the up/down arrows, move the cursor to the DATA AMP selection.
3. Change the value using either the left/right keys and knob, or the number pad and enter keys.
4. Change the value to +1.5V.

Press the "DATA OUTPUT" or the "ESC" key to remove the DATA OUTPUT window. *Note:* Decreasing data output amplitude too much will cause bit errors.

Change the Analyzer Data Input Threshold

1. Press the soft key "DATA INPUT" on the Analyzer side of display.

A pop-up window will appear:

DATA INPUT	SINGLE-ENDED
DATA THRES	.00V
DATA TERM	GND
DESKEW DELAY	.00 NS
POLARITY	NORMAL
STARTUP DELAY	0 clocks

This window displays the current operating parameters of the Analyzer Data Input. Use the up/down keys to select the parameter you wish to change. Pressing "ENTER" will invoke a new pop-up window that displays the selections for each parameter. Parameters that are values can be changed directly via the front panel entry keys.

2. Using the up/down keys select the DATA THRES.
3. Change the value using either the left/right keys and knob, or the number pad and enter keys.
4. Change the value to +.25V.

You have now set the Input Data Threshold to the center of the Generator Output Data voltage (Data VOH = +1.00V, VOL = -0.50V).

5. Press the soft key "DATA INPUT" or the key "ESC" to remove the pop-up window.

Change the Data Pattern.

1. Press the Generator Key "MORE", as needed to scroll.
2. Press the Generator key "DATA PATTERN"

A pop-up window will appear:

MODE	PRBS
PRBS	PRBS 7
MARK DENSITY	MARK RATIO 1/2
PRE-AMBLE	OFF
START MODE	STOP
LOAD PATTERN ...	
STORE PATTERN ...	
RECALL PATTERN ...	
MIXED MODE CONTENTS ...	

MODE indicates that the current mode is PRBS, the other choices are WORD or MIXED or MARK. Pressing enter will display these choices.

PRBS 7 indicates that the current PRBS pattern is 2^7-1 .

LOAD PATTERN provides a way to load pattern files from a diskette using a default naming convention and .pat file extensions. This supports only one set of pattern files per floppy diskette.

STORE PATTERN provides a way to store a pattern onto a diskette.

RECALL PATTERN provides a way to load pattern files from a diskette using an enhanced naming convention. This supports multiple pattern files per floppy diskette.

MIXED MODE CONTENTS allows you to specify the type of data transmitted in the PAYLOAD section of a MIXED MODE pattern.

3. Use the up/down keys to select PRBS data type
4. Press the key "ENTER".

A new window with the available PRBS codes will appear.

5. Use the up/down keys to select a new PRBS code.
6. Press the key "ENTER".

7. Press the key "DATA PATTERN" or the "ESC" key to remove the DATA PATTERN window.
8. Press the key "START/STOP" to restart the Generator with the newly selected PRBS code.

This will generate errors, because the Generator and Analyzer no longer have the same internal patterns.

Repeat the above procedure on the Analyzer side of the display to change the Analyzer Data Pattern to the same pattern as the Generator.

The SYNC LED will light to show that the Analyzer has synchronized to the Generator.

Setup for Mixed Mode Operation

1. On the Generator side, press the key "DATA PATTERN".
2. Use the up/down keys to select MODE.

We are going to load a MIXED pattern from floppy, therefore we will first change the mode from PRBS to MIXED. This can also be done after the download, but before the restart.

3. Press the key "ENTER".

A new window with mode choices will appear.

4. Use the up/down keys to select MIXED.
5. Press the key "ENTER".

The current internal mixed pattern will be loaded as indicated at the top of the display, "Transferring Pattern...", the MODE choices window will be removed, MODE will now show "MIXED".

Download a Pattern from Diskette

The PB200 has two methods for naming disk files — default and enhanced. Each method allows users to store and retrieve generator and analyzer pattern files from a floppy disk. File naming conventions for these methods are shown below:

File Type	Default Filenames	Enhanced Filenames
Generator Payload	gen_pyld.pat	<i>username.gpl</i>
Generator Overhead	gen_oh.pat	<i>username.goh</i>
Generator Mux	gen_mux.pat	<i>username.gmx</i>
Generator Preamble	gen_pre.pat	<i>username.gpr</i>
Generator Clock Gap	gen_gap.pat	<i>username.ggp</i>
Analyzer Payload	an_pyld.pat	<i>username.apl</i>
Analyzer Overhead	an_oh.pat	<i>username.aoh</i>
Analyzer Mux	an_mux.pat	<i>username.amx</i>
Analyzer Preamble	an_pre.pat	<i>username.apr</i>

If you use the LOAD PATTERN button, only files that match the default filename convention will be loaded. If you use the RECALL PATTERN button, only files that match the enhanced filename convention will be loaded.

1. Insert the “Sample Patterns” Diskette into the Floppy Drive of the unit.

Load a Mixed Mode Pattern from Floppy

1. On the Generator side, confirm you are in the "DATA PATTERN" menu. If not, press the "DATA PATTERN" key.
2. Use the up/down keys to select RECALL PATTERN.
3. Press the key "ENTER". The following window will appear:

```

      RECALL PATTERN

FILE TYPE:  OVERHEAD
FILE NAME:  ..No..Files
    
```

4. Position the cursor on the FILE TYPE entry and press ENTER. The following pop-up window will appear:

```

      FILE TYPE

OVERHEAD
PAYLOAD
MUX
PRE
GAP      (Generator only)
ALL
    
```

5. Position the cursor on the ALL file type and press ENTER. The following pop-up window will appear:

```

      RECALL PATTERN

FILE TYPE:  ALL
FILE NAME:  MPEG2_V2
    
```

(could be any user name)

6. Position the cursor on the FILE NAME entry and press ENTER. The following sample pop-up window will appear. *Note: filename list can be different - this list is for example purposes only.*

```

      FILE NAME

SAMPLE1
MPEG2
MPEG2_V2

SONETV12
ATM25MEG
    
```

*<- typical names of complete sets of files on a floppy
<- select this file if available*

7. Position the cursor on the *desired* FILE NAME entry and press ENTER. For this example, select the MPEG2_V2 file name. Note that the list of file names can be larger than the screen (indicated by a double line on the right of the pop-up menu). After loading, the final pop-up menu will be displayed as follows:

RECALL PATTERN		
FILE TYPE:	ALL	
FILE NAME:	MPEG2_V2	
PATTERN LOAD STATUS:		
PAYLOAD	COMPLETE	<- loads MPEG2_V2.GPL
OVERHEAD	COMPLETE	<- loads MPEG2_V2.GOH
MUX	COMPLETE	<- loads MPEG2_V2.GMX
PRE-AMBLE	COMPLETE	<- loads MPEG2_V2.GPR
CLOCK GAP	COMPLETE	<- loads MPEG2_V2.GGP

8. All of the selected pattern files should now be loaded. You should see the a Load Status of "**COMPLETE**" on all loaded files. If your file is named or formatted incorrectly, you will receive a **NOT READ** status.

Other Examples of Pattern and Setup Files

For a complete MIXED MODE example, you would need six different files loaded from your disk. If the files were stored using the “default filenames” they would consist of the following:

GEN_PYLD.PAT	Generator Payload contents
GEN_OH.PAT	Generator Overhead contents
GEN_MUX.PAT	Generator Multiplexer contents
AN_PYLD.PAT	Analyzer Payload contents
AN_OH.PAT	Analyzer Overhead contents
AN_MUX.PAT	Analyzer Multiplexer contents

When operating in WORD mode, you would need only one file for the Generator and one file for the Analyzer. The default names would be:

GEN_PYLD.PAT	Generator Payload contents
AN_PYLD.PAT	Analyzer Payload contents

To store *multiple* sets of pattern files on a disk, use a common prefix with unique suffix. The extensions for saved and loaded files are:

<u>Filename Ext.</u>	<u>Pattern</u>
.GOH	Generator OVERHEAD
.GPL	Generator PAYLOAD
.GMX	Generator MUX
.GPR	Generator PRE_AMBLE
.GGP	Generator CLOCK GAP
.AOH	Analyzer OVERHEAD
.APL	Analyzer PAYLOAD
.AMX	Analyzer MUX
.APR	Analyzer PRE_AMBLE

The Analyzer also has the capability to store and recall setups (analyzer only). This information is stored in binary form on a disk file with a file extension of .SRM.

This completes the “First Time Operation” section of the manual. For complete LAB instructions on Mixed Mode testing, refer to the Applications section in this manual.

Operating Basics

Operating Basics

This chapter first presents a functional description of the PB200. Following that is a description of the PB200 200 Mb/s BERT Transceiver hardware controls, indicators, connectors, and display elements for the Generator (Tx) and the Analyzer (Rx).

Functional Description of PB200

BERT Technology

Bit Error Rate Tester (BERT)

The PB200 is a BERT, that is, it generates a serial stream of digital data to a device under test (DUT), in turn, the DUT returns the data to the PB200 where it is synchronized and a bit-by-bit comparison is performed to determine the bit error rate (ERRORS/TOTAL BITS).

A basic BERT generates a Pseudorandom Bit Stream (PRBS) with a length of $2^N - 1$. N is typically 7,9,15,23, etc., a PRBS pattern with N=7 is referred here as PRBS-7.

These PATTERNS are generated in the Transmitter (Tx or Generator) and the Receiver (Rx or Detector), they operate in a continuous loop. The Receiver synchronizes the data returned by the DUT by either gating off (slipping) clocks to its internal generator, or for the longer codes, it will open its internal generator loop, feed the data into the loop, and then close the loop again (feed forward).

The FEED FORWARD method is used for long codes (PRBS-23) because it can take a very long time to clock slip through the pattern to synchronize, for example, up to 8 million clock slips to synchronize PRBS-23.

Most BERTs include a PROGRAMMABLE WORD. The programmable word allows the user to program customized patterns for testing the DUT, and also to program different patterns into the Tx and Rx, which is required in order to test devices that change the data before returning it to the Rx.

The Word patterns run continuously, like the pseudorandom patterns. However, the Word patterns are generated from HIGH SPEED MEMORY (RAM), unlike the pseudorandom patterns. The Word patterns, because of how they generated, cannot use the feed forward method for synchronizing long patterns. The Word patterns must use the clock slip method.

This is why long WORD patterns sometimes take longer to synchronize than a pseudorandom pattern. This depends on how many bits the Generator and Analyzer are offset by. In a continuously running BERT this offset is unknown. The PB200 STARTS AT A KNOWN INITIAL CONDITION.

Like other BERTs, the PB200 contains a Generator and an Analyzer with identical pattern generation capabilities. Being a RAM based design, the patterns can be programmed by the user or called from internal "canned" patterns. All but 2 of the "canned" patterns are stored in the RAM. The two long pseudorandom patterns, PRBS-23 and PRBS-31, are generated algorithmically.

The Analyzer measures the Bit Error rate of data returned to it from a DUT, it can also measure the propagation delay of the DUT, the BER "eye-width" of the data, the polarity, bit error rate, and the field location of the error.

Both the Generator and Analyzer are contained in a single box, along with the CPU and a synthesized clock source. There is a front panel user interface, along with the GPIB and RS-232C remote interface. Also pattern loading, and system software update can be accomplished via a 3.5" floppy drive.

PB200 Pattern Generator

The Analyzer and Generator each have the same pattern generator. The following description holds true for each, unless otherwise stated. The pattern generator consists of three 256 Kbits RAM and a PRBS generator, setup as shown in the figure below.

The transmitter Data Generator section consists of three 256 Kbits of high speed RAM-based pattern generators called MUX, Payload, and Overhead. The purpose of the MUX RAM is to multiplex the transmitter clock between the Payload and the Overhead RAM, thus allowing for mixed pattern generation. When a MUX bit is set to zero the Payload RAM is selected, and when it is set to a one the Overhead RAM is selected. All of the data generator RAM are similar in architecture with the exception of the payload RAM which includes a PRBS generator. Due to the long pattern length of PRBS codes, a hardware algorithm is used to create these long patterns (for example, PN31 would require 2 Gbits of storage space).

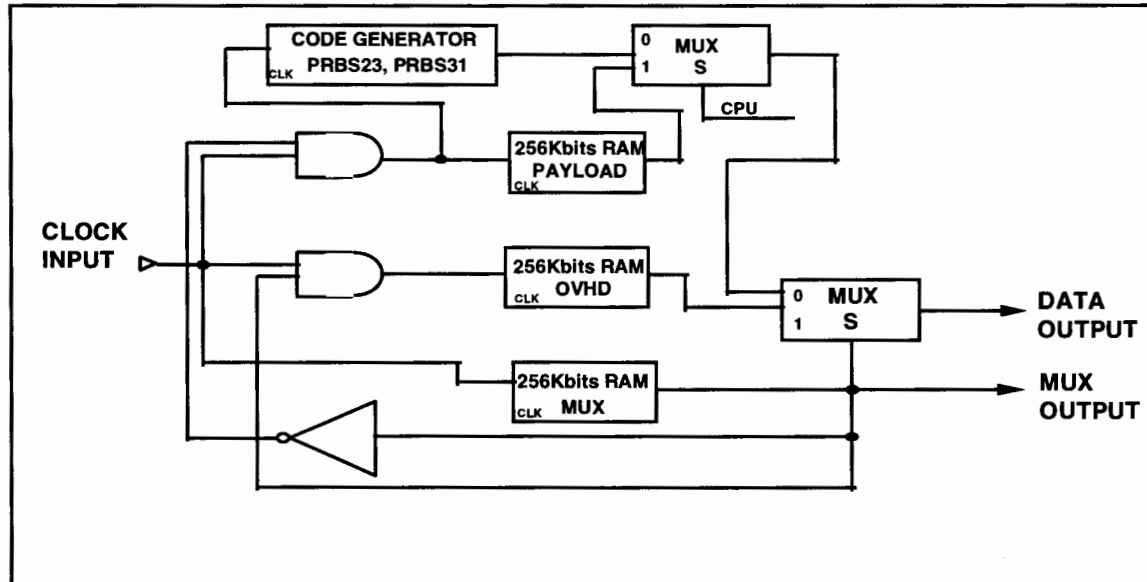

Figure 2-1. Pattern Generator Block diagram

The PAYLOAD RAM is where a user would typically store the data that will be used to simulate transmitted data.

The OVERHEAD RAM is where a user would typically store data used for protocol and other overhead information.

The MUX RAM is where the user stores the control, for switching between the Payload and the Overhead.

When a Payload bit is being clocked out, the Overhead MUX is held and vice versa, this makes it possible to generate very long mixed patterns. To simplify use of the pattern generator we have defined THREE BASIC MODES of operation. The first is PRBS, the second is WORD and the third is MIXED.

In PRBS, the user is given a list of the internally stored PRBS and PRBS Mark Density patterns, the user selects a one pattern. These patterns are automatically loaded into the Payload RAM, or in the case of PRBS-23 and PRBS-31 routed from the Code Generator circuit. The MUX RAM is set to a logic zero, the OVERHEAD RAM is not used.

In WORD, the user is given the ability to store a word pattern up to a length of 256 Kbit. The word is stored in the Payload RAM, again the MUX RAM is set to a logic zero, and the Overhead RAM is not used.

In MIXED, the user must specify the length and content of the Payload, the Overhead, and the MUX RAM. For Payload content, the user can select either the Payload RAM, or a PRBS pattern (from the PRBS selection). The Overhead and MUX RAM are defined by the user. The figure below shows an example of a very simple mixed pattern to illustrate how the MIXED mode pattern generator works.

	<u>Contents</u>	<u>Length</u>
MUX RAM	FE0000	3 Bytes
Overhead	F0F0	2 Bytes
Payload	PRBS15	$2^{15}-1$
	<u>OH PYLD (PRBS-15) OH PYLD (PRBS-15)</u>	
DATA	1111000 111111111111111100 0111100 0000000000001000 ...	
MUX	1111111 000000000000000000 1111111 0000000000000000 ...	

Figure 2-2. Example of MIXED pattern

When operating in the MIXED mode it is important to pay special attention to any SWITCHING that is done in the external CLOCK PATHS (the Generator EXT. Clock, or the Analyzer EXT. Clock).

In any of the three basic modes, a glitch (< 2 nS pulse width) occurring on these lines may cause the Address generators to become unsynchronized. In PRBS or WORD mode the unit will re-attempt and gain synchronization. This is what most BERT users are familiar with.

In MIXED mode, the unit will NOT re-gain sync until the user stops the Generator and restarts it. This is because there are multiple address generators being used to generate the MIXED data patterns. When a clock, that does not meet the input specification, enters the Generator or Analyzer it may cause the address generators to become unsynchronized.

Switching CAN be done in these paths if the user performs it without causing glitches. If the user does cause glitches he must stop and re-start the Generator, this will re-synchronize the address generators.

Error Injection

The transmitter Data Generator is capable of error injection at various rates into the Payload, Overhead, or All. This error injection process is done by randomly inverting bit(s) from the data pattern stream. The transmitter is capable of injecting a single error or selecting a programmable rate which has the range of 10^{-n} , where n is 3, 4, 5, 6, or 7. It is also possible to inject user defined error rates by using the external rear panel BNC connector labeled "Ext Error Inject".

The error injection field is selectable to Payload only, Overhead only, or All (Payload and Overhead). In 'MIXED' mode of operation, this feature gives the user the maximum flexibility so that errors can be injected into the specific data field, that is, Overhead, Payload, or All or Payload. When the Overhead or Payload field is selected, the errors are inserted in the selected field and the error rate is defined by the data rate at which the selected field is running. In 'All' mode, this rate is defined by the transmitter data rate (i.e. clock frequency).

When using the external rate, the error injection circuitry has to synchronize the incoming rate to the transmitter clock frequency. Because of this synchronization process the transmitter takes at least two clock periods (bit cells) from the time the actual error was injected through the rear panel. The rear panel connection is TTL compatible input.

Output Amplifiers

There are two sets of high speed pin-driver electronics that provide differential Data and Clock to the unit under test. These pin drivers both have programmable offset and amplitude controls which allows interfacing of the transmitter data and clock to a variety of logic families. Refer to the following figure for the model of output amplifiers.

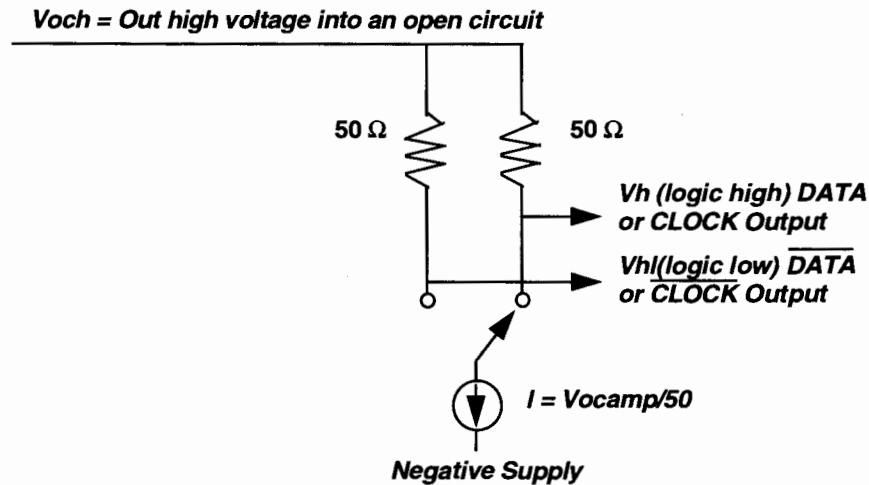

Figure 2-3. Model of Output Amplifier

These output amplifiers are capable of driving a 50 Ohm load (terminated to ground) with 2V peak-to-peak maximum amplitude. If the output is left unterminated, that is >2 KOhms termination impedance, the output amplifiers will drive an unterminated load to 4 Vpp. The transmitter offset and amplitude are displayed and calibrated into a 50 Ohm to ground load. Also when terminating to voltages other than ground, the output will inherit a DC shift in offset voltage. As a general rule, terminate unused outputs with a 50 Ohm impedance.

The Data output from the transmitter is in True/Complement NRZ format and the Clock output is in True/Complement format. When using the transmitter outputs in the single-ended mode, make sure the unused outputs are terminated properly otherwise distortion in the waveform will be introduced.

A programmable delay is also provided in the data output path to allow the user to alter the skew between the clock and the data output. The primary use of the delay is to vary the timing so that the interface to DUT. can be adjusted by the user.

The transmitter is calibrated so that when the output delay is set to zero, the rising edge of the clock is edge aligned with the output data crossing. This delay has a range of +/-1ns. The user is also able to inhibit the Data output (force to logic low) using the rear panel Data Inhibit input. This input is ECL compatible, hence it is terminated 50 Ohm to -2V inside the PB200.

Internal Clock Source

The PB200 is equipped with an internal clock synthesizer which is used to set the rate at which the data generator/analyzer are running. The internal clock source can be separated into five functional blocks. These blocks are: External Reference loop, Direct Digital Synthesizer, Frequency multiplier, External Clock input, Clock gapping.

External Reference loop: PB200 uses a high grade temperature compensated crystal oscillator for generating a base clock frequency for the synthesizer. However, in some applications where higher clock stability and accuracy is desired, the user can connect an external 10 MHz reference clock to the rear panel BNC so that the internal synthesizer will operate from the desired external crystal.

This external 10 MHz reference is internally scaled by a factor of six by using a phase lock loop. The user can monitor the lock status of this PLL to guarantee that the PB200 has properly locked. In the External reference mode of operation, the internal crystal is turned off. To utilize the internal crystal again, a minimum of twenty minutes is required for warm up time before the crystal is stabilized.

Direct Digital Synthesizer: The DDS main function is to provide an octave frequency range for the main frequency multiplier and to provide clock frequencies as low as one hertz with high frequency precision.

Frequency Multiplier: The main purpose of this circuit is to multiply it's reference clock, in this case the DDS output, so that frequencies of up to 200 MHz can be produced internally.

External Clock input: In order to entirely bypass the internal clock synthesizer of the PB200, the user can operate the transmitter from an external clock source. This connection is made from a BNC connector located on the front panel of the instrument. This external clock input of the transmitter has four selectable termination voltages, that is, GND, -2V, +3V, and AC with 50 Ohm impedance in order to satisfy different interfacing requirements.

Clock gapping: This is a unique feature in the PB200 clock synthesizer that allows the user to generate "Bursty" clocks, hence producing "bursty" data patterns. The output from the internally synthesized clock or the external clock input comparator can be used to control the clock gapping circuit, thus allowing gapping function on internally synthesized clock or external clock provided by the user.

The clock gapping is performed by logically ANDing the clock and the output from a programmable pattern generator. The pattern generator is similar to the one used to generate data patterns in the PB200, that is, high speed 256 Kbits RAM-based pattern generator. Due to this flexible architecture the user is able to produce bursts of packetized data.

PB200 Clock Gap

The PB200 contains a clock source that can be gated on and off. A "clock gap" feature has been added to provide the user with a method of simulating packets of data. A separate pattern generator is provided for this purpose. A block diagram is shown below.

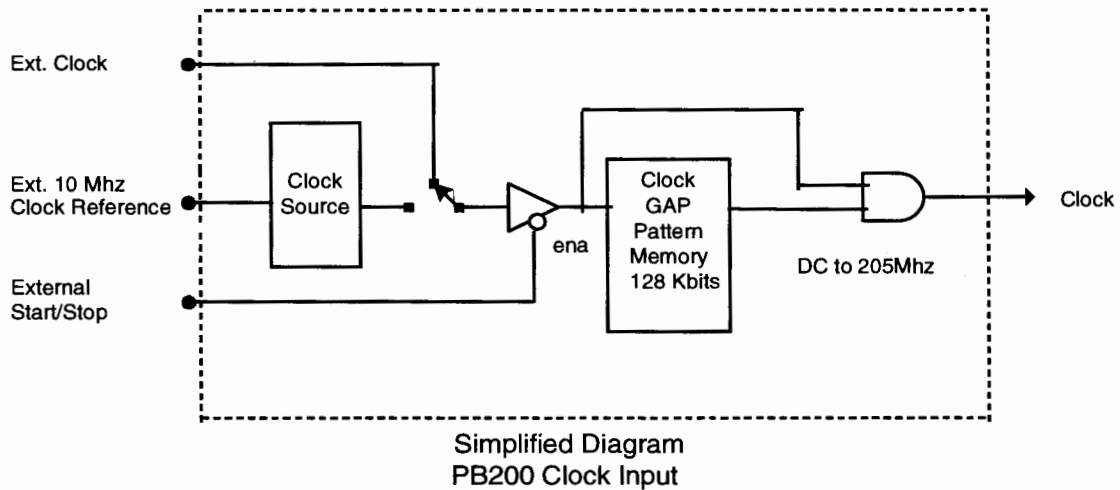

Figure 2-4. Block diagram - PB200 Clock Input

The clock source can be used in two different modes. In NORMAL mode it functions without any gating, in GATED mode the clock output (before it goes to the pattern generator) is gated by its own separate pattern generator. This pattern generator consists of a high speed RAM. The length is programmable, up to 128 Kbits.

A logic one in the clock gap memory enables the clock, a logic zero in the clock gap memory disables the clock.

In the following example, a 4-byte pattern is loaded into the clock gap memory. It produces a clock output with gaps every 10, 12, 13, 14, 15 and 16 clocks.

	Contents	Length
Clock gap memory	FFA0	4 bytes

Gate	1 1 1 1 1 1 1 1	1 0 1 0 0 0 0 0
Clock	01 01 01 01 01 01 01 01	01 00 01 00 01 00 01 00

Figure 2-5. Example of Gated Clock

PB200 Continuous/Start Mode

The PB200 can be operated in 2 different Run Modes, Continuous and Start.

In CONTINUOUS mode, the PB200 operates like a standard BERT, that is, the Generator and Receiver are always running unless the user has stopped or paused it from the front panel start/stop or pause/resume buttons. If the user changes the type of pattern or edits the pattern, once completed, the unit will automatically resume running.

In START mode the user must start the unit after changing or editing patterns. In either of the two modes when the unit starts it always starts at the initial condition (beginning of a PRBS pattern, Address 0 of the RAM).

Continuous mode is for users that don't want to keep pressing the Start button after changing patterns, Start mode is for users that want control of the beginning of the test.

Synchronization, Startup and Propagation Delay

How does the PB200 synchronize to an incoming pattern?

Synchronization methods for BERT test equipment will vary by application, pattern type, and instrument design. The PB200 uses a “clock slip” method of synchronization. For this synchronization process, a number of bits will be examined until either a SYNC or SYNC LOSS condition can be declared. This process is then repeated indefinitely. Once a valid synchronization is achieved, the “clock slip” mechanism can be disabled and a timed BER test can be started. A flow chart of this process is shown in the figure below.

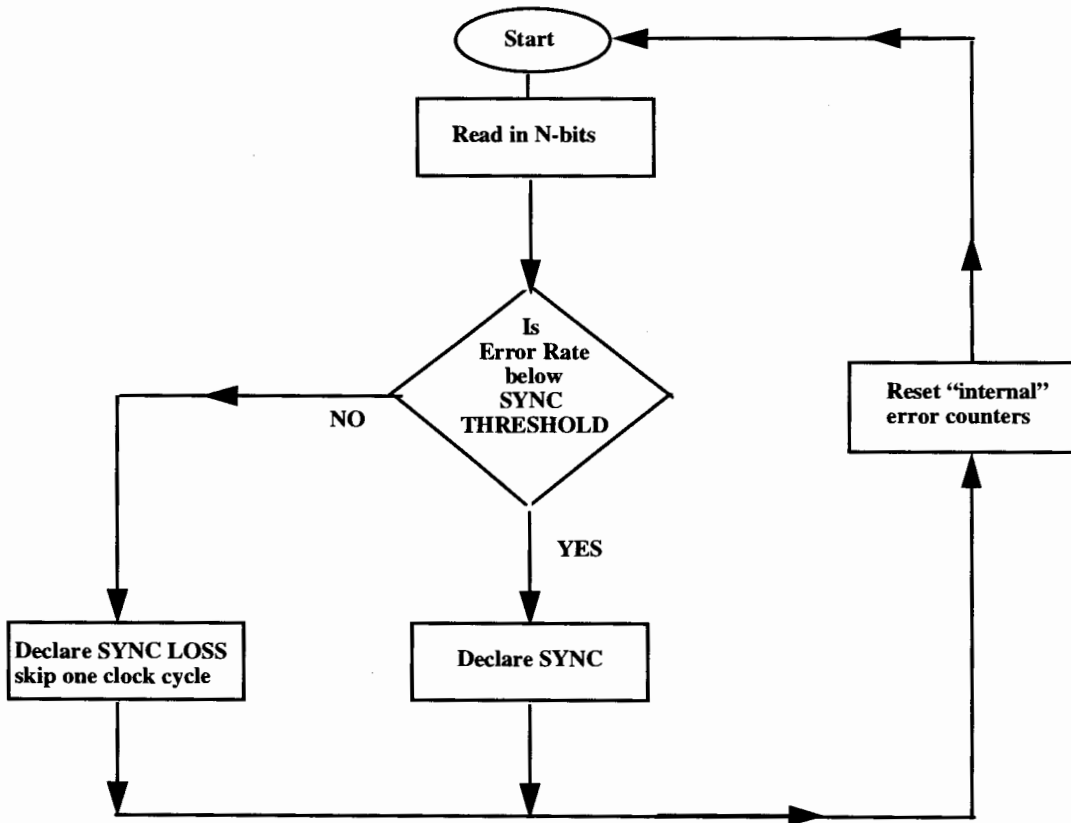

Figure 2-6. Simplified flow chart for clock slip synchronization

Let's take an example using a PRBS PN23 signal. PRBS signals have approximately a 50% (i.e. almost even) distribution of one's and zero's. Let's say you start your BER receiver and read in and compare the first 200 bits (clock cycles) of information for an incoming PRBS pattern. If the incoming pattern is not perfectly aligned with the expected pattern, you should get a 50% error rate DUE TO THE NATURE OF THE PRBS signal.

With a custom pattern, it is more difficult to predict how many bits you must read in before the error rate is above or below a particular threshold. See the chart below. Worst case, you would read in 1024 bits of information (for the level 1 or 25% threshold) before you slip a clock.

When the error rate is above the instruments SYNC THRESHOLD, the receiver will slip one clock cycle (skip a clock) and start the sync process over again. The following chart gives some of these numbers.

Simplified chart for clock slip synchronization

Error Mode Sync Level ¹	Sync Threshold ¹ (ratio)	Sync Threshold ¹ (%)	# errors required ²	total #bits to read in before valid sync declared ³ (fixed by instrument s/w)	#bits before clock slip for PRBS ONLY ⁴
1	2.50E-1	25.0	256	1024	512
2	6.25E-2	6.25	256	4096	512
3	1.5625E-2	1.5625	128	8192	256
4	3.9E-3	0.390	128	32768	256
5	9.8E-4	0.09765625	64	65536	128
6	2.44E-4	0.0244	64	262144	128
7	6.1E-5	0.0061	64	1048576	128
8	1.52E-5	0.0015	64	4,194,304	128

Notes:

- 1 Sync threshold - this is the value set by the Analyzer "Error Mode" window via the SYNC THRESH parameter. You enter a value from 1 to 8 to specify different synchronization error thresholds used by the analyzer. A value of 1 is the DEFAULT and is the best value to use with pure PRBS patterns. Certain mixed mode or word patterns will require higher levels to achieve synchronization.
- 2 This number is set (fixed) by the instrument software based on the error mode currently in use.
- 3 Total #bits - a fixed value by instrument firmware based on the error mode "sync threshold"
- 4 If an incoming PRBS pattern is not aligned, you should receive approximately 50% error rate. If you are NOT SYNCHRONIZED, this means you would have to read in 512 bits (clock cycles) of data before the error counter reached 256 errors.

Examples of Sync Operation with straight PRBS data:

With a 25% sync error threshold used (default error mode threshold - level 1), you read in 512 bits of information before you know if you have to slip a clock or not. If you are done “clock slipping”, you now read in 1024 bits of information to determine if you have reached a valid sync state. If the error rate is still below the sync threshold, you are now “in-sync”. At this point, you should reset your error counters, disable clock slip operation, and start your BER test.

With a 1.5625% sync error threshold used (error mode threshold - level 3), you read in 256 bits of information before you know if you have to slip a clock or not. If you are done “clock slipping”, you now read in 8192 bits of information to determine if you have reached a valid sync state. If the error rate is still below the sync threshold, you are now “in-sync”. At this point, you should reset your error counters, disable clock slip operation, and start your BER test.

Because the PB200 resides in a single box it is possible to start the Generator and the Analyzer simultaneously. When they are started, they start at a defined location, the beginning of a PRBS pattern, or Address 0 of a WORD or MIXED pattern. Since they start at the same location, at the same time, they are therefore started already Synchronized.

This means that a DUT (Device Under Test) with a propagation delay of 0 nS will not require any synchronization time, regardless of the pattern length. Most DUTs do not have a propagation delay of 0 nS, which means that it may require clock slips (time) to synchronize. The synchronization time depends on how large the propagation delay is, the clock speed and the pattern type.

The PB200 has the ability to count the number of clock slips (up to 64 Kbits) required to gain sync. This value multiplied by the clock period and added to the Analyzer input programmable delay yields the PROPAGATION DELAY of the DUT. The Propagation Delay measurement is automatically generated by the analyzer for all input signals within range.

This in itself is useful information for most users, however, the PB200 can use this information to start the PB200 Analyzer later (up to 64 Kbits) than the Generator, thereby compensating for the users DUT propagation delay, once again making it possible to start the unit already synchronized.

For users that have DUT propagation delays greater than 64 Kbits it is possible to start the Analyzer with a delay of 64 Kbits, then get the clock slip count and add the two values. This makes it possible to measure propagation delays up to 128 Kbits. Compensation can only be done up to 64 Kbits, unless the user wishes to download bit skewed patterns to the Generator and Analyzer RAMS.

If the user is unable to start the Generator and Analyzer at the same time (for example using separate boxes at remote sites) the Analyzer will not be able to measure the DUT propagation delay, however it will still slip clocks until it gains sync. For long patterns this may take a long time, it is similar to using a standard continuously running BERT.

Sync times are related to the clock speed and pattern length. Higher clock speeds will reduce sync times while longer pattern lengths (for example, PRBS $2^{23}-1$ or $2^{31}-1$) will increase sync times.

Analyzer Inputs

This section discusses the Analyzer clock and data inputs and also the Analyzer clock disable feature. For proper operation, the PB200 Analyzer requires a clock and data. The data input is the signal under test, the clock input is required to sample the data input to decide if it is a logic one or zero. The same clock is then used to generate one bit from the internal reference pattern. The sample is then compared to the reference pattern for errors.

The CLOCK is being used to sample the data, therefore it should be kept as "clean" as possible. One way to get a clean clock is to use the internal clock, which is routed internally from the Generator to the Analyzer. When using the internal clock it is not necessary to supply a clock to the Analyzer front panel.

The front panel clock can be either differential or single ended. When using a single ended clock the internal threshold should be set to the center of the clock voltage swing. The variable threshold is provided for this purpose, it should not be varied for testing purposes, as this could cause improper Analyzer operation.

The clock input has four selectable termination voltages (GND,-2V,+3V,AC) to satisfy different interface requirements.

The DATA input is provided for the signal to be tested. As with the clock input, this signal can be either differential or single ended, and there are four selectable termination voltages.

The user will select the termination voltage depending upon the interface requirements. When the input is being used in the SINGLE ENDED mode the user can either manually set the threshold or allow the unit to set it to the center of the data input voltage swing using Auto Search. The threshold is commonly varied to test for input signal vertical "eye" height.

A programmable delay is also provided in the data input path to allow the user change the timing between the clock input and the data input. The primary use of the delay is to change the timing so that the clock samples the data in the center of the data bit.

At all frequencies, the rising edge of the analyzer input clock is considered to (time zero). The data will be sampled on the following edge of the input clock, plus any programmed delay time.

The PB200 is calibrated so that when the data crossing and the clock rising edge are aligned at the Analyzer front panel inputs the clock will be 2.5 nS after the data crossing at the sampling DFF (the center at 200 MHz).

When the INTERNAL clock is used this same timing relationship will exist when the data crossing at the Analyzer input is 3 nS after the rising edge of the clock at the Generator clock output.

Another important use of the programmable delay is that it provides the means with which to measure the BER "eye-width" of the signal under test.

Reference Pattern Generator

The reference Data Generator section consists of three 256 Kbits high speed RAM-based pattern generators called MUX, Payload, and Overhead (similar to transmitter Data Generator). The purpose of the MUX RAM is to multiplex the transmitter clock between the payload and the overhead RAM, thus allowing for mixed pattern generation.

When a MUX bit is set to zero the Payload RAM is selected, and when it is set to a one the Overhead RAM is selected. All of the data generator RAM are similar in architecture with the exception of the payload RAM which includes a PRBS generator. Due to the long pattern length of PRBS codes, a hardware algorithm is used to create these long patterns (i.e. PN31 would require 2 Gbits of storage space). At startup, PN23 and PN31 are initialized to pattern 0x004000 and 0x00400000 respectively.

Synchronization

The PB200 Generator and Analyzer start at the same time, and at the bit location. This means that if there is a propagation delay from the Generator output to the Analyzer input there will be a need to "synchronize" the Analyzer pattern with the Generator output pattern. Synchronize here means align the test pattern with the reference pattern.

To compensate for this delay the Analyzer SLIPS its internal clock to delay the reference pattern by one or more clock periods. The PB200 must first however determine whether or not the two patterns are synchronized. The sync threshold circuit is used to decide when to slip. The user selects a percentage (25% to .0015%) of errors to bits to be used as the sync criteria. Lower percentages are for patterns that will false- frame at low error rates, and therefore they must examine more bits.

The default error mode sync threshold of 25 percent is used mainly with PRBS patterns.

SLIP Enable/Disable

The Analyzer will SLIP clocks until the sync threshold criteria is satisfied. The clock SLIP circuit can be disabled once the Analyzer gains sync to measure error rates above the sync threshold error rate.

No Synchronization Required

The PB200 Analyzer can be programmed to START up to 64 Kbits later than the Generator. If the user knows the propagation delay of the DUT and divides that by the clock period he will get the value (truncate) to program into the startup delay. The analyzer will wait until the first data bits show up to begin the error rate testing, NO SYNCHRONIZATION will be required. The PB200 will also run using a gated clock, which means that if the clock is gated or held low until the first data bit is available it will be started "in sync".

The PB200 also provides a Clock Disable input to allow the user to supply a constant clock, and gate it off when there is no data. This will keep the Analyzer synchronized with the data source.

Auto Search

The Auto search feature is provided to automate the many adjustments required to analyze a data pattern. This feature greatly reduces the time spent setting up the analyzer.

Auto search functions can be individually enabled or disabled. These functions are:

- *Adjust Clock Threshold* - The CLOCK signal is examined to find the center of the voltage swing, the threshold is set to the center of the active range.
- *Adjust Data Threshold* - The DATA signal is examined to find the center of the voltage swing, the threshold is set to the center of the active range.
- *Adjust Input Delay* - The input delay is varied to find the largest continuous range with phase errors. Phase errors occur when the data transition is too close to the sampling clock.
- *Internal Patterns* - The internal patterns PRBS, MARK, WORD, and MIXED are separately enabled. The ones that are enabled will be searched. For example if the PRBS patterns are enabled, each code from PN7 to PN15 will be tried. The internal pattern search has a time limit in seconds that is selectable. PN23 and PN31 are not included because of the long time required to synchronize.
- *Polarity* - The polarity of the data input is tried in both normal or invert. When Auto search is enabled the SLIP enable/disable is set to the enabled state.
- *Time* - The time in seconds, allowed for each pattern to synchronize.

Error, Frequency Measurements

Frequency

The PB200 measures the frequency of the clock signal that is supplied at the front panel or coming internally from the Generator. The measurement is done over a 1 second sliding window. It is updated every 200 mS.

When a non-continuous clock (gap clock) is in use, you will receive an "average" frequency measurement over the sliding window.

Total

The PB200 Analyzer examines every bit and counts every error occurring in the data pattern. This is the total error count. This count can be reset by starting the pattern over or by pressing the CLEAR key on the front panel. This count is automatically reset whenever the Analyzer gains sync.

Error Rates

The PB200 counts every error in the data and every clock cycle (bits). The ratio of errors to bits is the Bit Error Rate (BER). There are three modes of BER measurements.

Total BER --Errors are averaged over the time of the test. The test period begins when the Analyzer gains sync or after the CLEAR key has been pushed. This mode is mainly for long term tests.

Simultaneous Measurements

The PB200 can simultaneously make the following measurements Errors (both ones and zeroes errors)

1s-only errors

0s-only errors

There are two error counters, one that counts all of the errors and a second that counts errors only when the EXPECTED data bit is a logic one (ones that where corrupted to zeroes). The PB200 displays these as ERRORS , and 1'S ONLY ERRORS.

By subtracting the 1's errors from the errors, the 0's errors can be calculated. The above three modes: TOTAL, WINDOW, and TEST are available for ERRORS, 1s-only, and 0s-only.

Error Field

- All-errors
- Payload-only errors
- Overhead-only errors

The error counters can be gated by the MUX output from the Analyzer pattern generator. If All errors is selected this gating function is disabled. If PAYLOAD ONLY is selected it is used to gate off the errors occurring during the Overhead section of the pattern. If OVERHEAD ONLY is selected, it is used to gate off the errors occurring during the payload section of the pattern.

The bit counter is NOT gated by the MUX output, due to it's multiple functionality. Therefore to calculate the BER over payload or overhead the bit counter is multiplied by the ratio of payload to total bits for payload error rate or overhead to total bits for overhead error rate.

The three modes: TOTAL, WINDOW, and TEST and the three types ALL, 1s, and 0s are available for each of the field error rate measurement.

BER Eye-Width Measurement

The term "Eye Opening" is defined as the region between data transitions in which the bit error rate (BER) is not exceeded. For example, Fibre Channel defines this as 57% of a unit interval (UI) where the BER is $1E-12$. For a 1.0625 Gb/s signal, this would translate to ~536 pS.

Eye-width measurements can be made using oscilloscopes or BERT equipment. Oscilloscopes provide quick results with lower accuracy while BERTs provide slow results with higher accuracy.

The PB200 can make eye width measurements using either the "Phase" mode or the "BER" mode. "Phase" mode is analogous to a scope measurement and "BER" mode is the higher accuracy Bit Error Rate method.

The PB200 Analyzer can measure the bit error rate BER "eye-width" of the signal under test. The BER eye width is the width of the data bits that are at or below a user specified BER.

When the user presses the eye width button, the PB200 does a BER eye-width measurement. The user can select PHASE or BER. The BER mode also has an EXTRAPOLATION on/off choice. The user should be aware that the eye width will be measured at the current voltage threshold, varying the threshold will change the eye width.

Phase Mode

In the PHASE mode the unit then sweeps the entire input delay range to find the data crossings using the PB200 PHASE indicator. It then takes the 2 crossings closest to a delay value of 0 and samples several points near them to determine the eye width.

If only one crossing is found (at low frequencies) the PB200 will sample around it to determine how wide the transition region is. It will then subtract that from the period of the waveform to calculate the eye-width. The PB200 will tell you that the eye-width is based on a single edge calculation.

The phase indicator is a circuit that determines when the sampling clock is near the data transitions. This method is very fast because no synchronization or BER measurements are necessary.

BER Mode

In the BER mode the user must select whether or not to use EXTRAPOLATION (see below) and also two parameters. The first parameter is simply the BER at which you require to pass the test.

The second is the sample size.

How many bits you require to do each BER measurement. For example if you chose $1e9$ as the BER, you could select a sample size of $1e9$ for a fast BER measurement, or maybe $1e10$ for a more accurate measurement. Since $1e10$ bits are in the sample it would take 11 errors in $1e10$ bits to fail the BER measurement.

The PB200 then sweeps the entire input delay as in the fast mode above, finds the two transition regions closest to 0 delay, then samples around them to determine the eye width. If only one crossing is found (at low frequencies) the PB200 will sample around it to determine how wide the transition region is. It will then subtract that from the period of the waveform to calculate the eye width. The PB200 will tell you that the eye width is based on a single edge calculation.

Extrapolate "ON"

Some users will be measuring very low BERs ($1e^{-11}$, $1e^{-12}$ etc..) Since these measurements take a very long time it would be better to make multiple measurements at higher BERs and extrapolate to the desired low BER. This of course assumes that the device under test has a predictable BER curve. The PB200 assumes a logarithmic curve

The user selects the BER and sample size for the two higher BER measurements. The PB200 automatically finds the highest error rate eye width first, then the lower error rate eye width. These two values are used to extrapolate the eye width at the desired lower BER.

PB200 Error Rates

In addition to the standard BER calculations, the PB200 has several other types of BER measurement. These are :

- Simultaneously available:
 - Normal errors (both ones and zeroes errors)
 - Logic ones only
 - Logic zeroes only
- Selectable, error field:
 - All
 - Payload
 - Overhead

There are two error counters, one that counts all of the errors and a second that counts errors only when the EXPECTED data bit is a logic one (ones that where corrupted to zeroes). The PB200 displays these as "ERRORS" , and Errors. By subtracting the 1's errors from the errors, the 0's errors can be calculated. These rates are available simultaneously.

The MUX output from the Analyzer pattern generator can be used to gate the All and Ones error counters. If All errors is selected the gating is not used. If Payload is selected it is used to gate off errors occurring during the Overhead section of the pattern. If Overhead is selected, it is used to gate off the errors occurring during the payload section of the pattern.

If a user had selected Payload or Overhead, the Ones display would display the error rate of the "missing" ones in the payload or overhead section of the DUT data respectively.

Controls, Indicators and Connectors

The front panel is divided into eight sections:

Display and soft keys	Entry keys
Power switch	Utility
Pattern	Analyzer
Floppy drive	BNC connectors

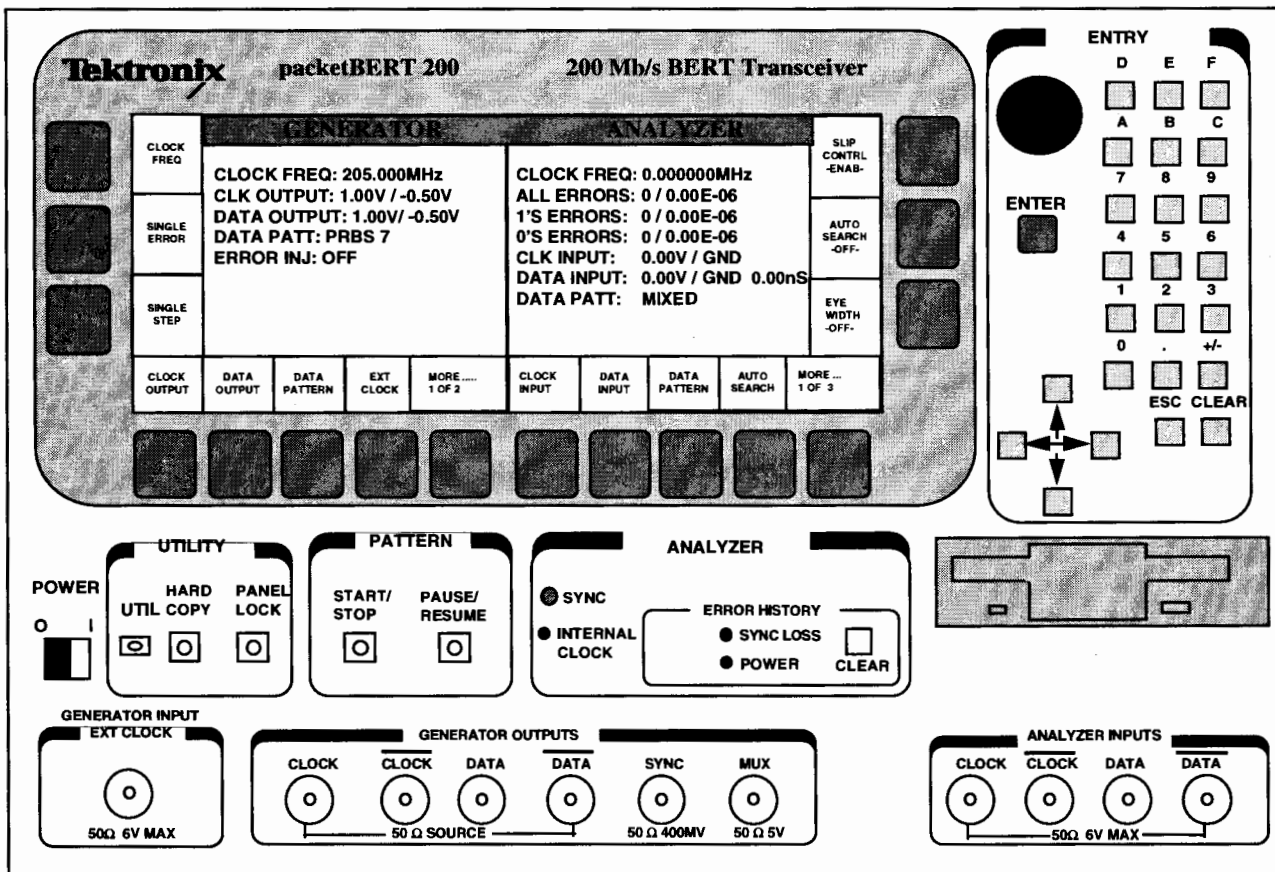

Figure 2-7. Front Panel - PB200

Entry Keys

The ENTRY keys are used to change values, selections, and move the cursor. Values changed by the knob are immediately written to the hardware. Values changed by the keys are either entered by the ENTER key or abandoned by the ESC key. Softkeys can be used to bring up pop-up windows, and the ESC key is used to remove pop-up windows.

Power Switch

The ON/OFF power switch is located on the left side of the test instrument below the LCD screen. The power switch switches the 120VAC to the system power supply. When off, a Battery backup circuit powers the non-volatile RAM.

STATUS indicates whether the Analyzer was able to measure or calculate the eye width. The value in parentheses indicates how the value was determined (see page A-20).

EYE WIDTH gives the value of the eye width measurement or calculation. The table of values, are the points (A1-C2, see figure 4.3) measured at the 3 set BER eye width thresholds.

UTILITY

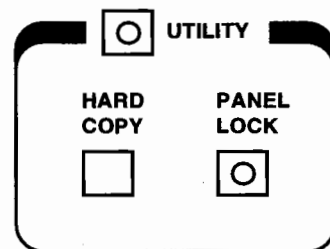

The UTILITY box contains many general functions that are usually associated with the user interface.

Press the HARDCOPY key to get a hardcopy of the current Generator and Analyzer status.

Press PANEL LOCK to lock the front panel keys out. LED is lit when function is active.

Press UTILITY to bring up the utility menu with soft keys on the front panel LCD display. The internal key LED lights when this key is active. The utility menu has the following selections. Press utility to exit the utility submenu.

Print

The PRINT soft key is used to select the active print device. Repeatedly pressing the PRINT key causes the selection to rotate between RS232, LPT, and GPIB.

Left Display Control

Press LEFT DISP CNTL to change items displayed on the left of the LCD display. Some items can be removed, the size of the characters can be changed, and some items can be made to automatically change to a larger size character when they are being used.

LEFT DISP CNTL

LARGE ERR INJ --> ON, OFF, AUTO

CLOCK/DATA OUT --> ON, OFF

Select LARGE ERROR INJ to change the display character size to normal (OFF), large (ON), or large only when error inject is used (AUTO).

Select CLOCK/DATA OUTPUT to add (ON) or remove (OFF) the clock and data output parameters display.

Right Display Control

Press RIGHT DISP CNTL to change items displayed on the right side of the LCD display. Many different measurement results are available with the receiver, and not all results can be displayed at the same time.

RIGHT DISP CNTL

CLK FREQ --> ON, OFF, AUTO

LRG ERR RATE --> ON, OFF

LRG ERR --> ON, AUTO

1's ERR --> ON, OFF

0'S ERR --> ON, OFF

SLIDING WINDOW --> ON, OFF, AUTO

CLK/DATA IN --> ON, OFF

PROPAGATION DELAY --> ON, OFF

Select CLK FREQ to add (ON) or remove (OFF) the CLOCK FREQ display.

Select LARGE ERROR RATE to make the characters normal (OFF), large (ON), or normal until an error occurs then change to large (AUTO).

Select LARGE ERRORS to make the characters normal (OFF), large (ON), or normal until an error occurs then change to large (AUTO).

Select 1's ERROR to add (ON) or remove (OFF) the 1's errors display.

Select 0's ERROR to add (ON) or remove (OFF) the 0's errors display.

Select SLIDING WINDOW to add (ON), remove (OFF) or mode (AUTO) display the sliding window measurement length. AUTO displays the length only when the window data measurements are displayed.

Select CLOCK/DATA INPUT to add (ON) or remove (OFF) the clock and data input parameters display.

Select PROPAGATION DELAY to add (ON) or remove (OFF) the propagation delay display.

Factory Default

Select Utility, then FACTORY DEFAULT to reset the unit to its factory default settings. Data patterns are not altered, however, the default PRBS pattern is selected. This selection is useful to clear custom settings when it is time to run different tests.

FACTORY DEFAULT

Reset Setting? YES

When FACTORY DEFAULT is selected a window will pop-up to ask if you want to reset setting. Pressing the FACTORY DEFAULT key again is reset without doing the default setting, (YES) will perform the default setting.

RS-232

Press RS-232 to customize the RS-232 interface.

RS-232

BAUD RATE --> 9600, 4800, 2400, 1200, 300

PARITY --> NONE, EVEN, ODD

DATA SIZE --> 7, 8

STOP BITS --> 1, 2

ECHO --> ON, OFF

XON/OFF --> ON, OFF

EOL TERMINATOR --> CR/LF, CR, LF/CR, LF

GPIB

Press GPIB to customize the GPIB interface.

GPIB	
GPIB ADDRESS	(value 0-30)
GPIB TERM -----	
GPIB BUS MODE ----	EOI ONLY
OFF BUS	EOI/LF
TALK/LISTEN	

Remote

Press REMOTE to customize the values between the PB200 and the remote device.

REMOTE	
COMMAND HEADER -----	
DEBUG MODE ---	ON
ON	OFF
OFF	

More

Press MORE to view more of the menu selections that are available on the bottom row of the soft keys.

Time Date

Selecting TIME DATE allows the user to set the time and date of the device. Pressing the button causes the following window to pop up on the screen. Use the arrow keys to position the cursor to the field you want to change, then use the twist knob to change the field. Use the arrow keys to position the cursor over the <SET TIME/DATE> field and hit enter to set the time and date.

TIME/DATE	
CURRENT DATE:	10/16/99
CURRENT TIME:	03:38:36
	AM
<SET TIME/DATE>	

Monitor

Select MONITOR to swap between the front panel LCD and the rear panel video connector. This allows the user to connect a VGA CRT for group viewing. This selection would be used if an external VGA monitor was being used so a group of people could see the test status and results all at the same time. The front panel display is not available when the display output is being seen on an external VGA monitor

Contrast

Select CONTRAST to adjust the LCD display contrast. Use the knob in the entry keys section to adjust the contrast. The range of values is 0 - 9.

PATTERN

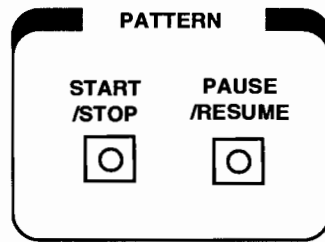

The pattern box contains two keys. These keys are used to control the operation of the unit.

The START/STOP key is used to start the generator at the beginning of the data pattern, or stop the generator. When stopped, the clock is stopped. The green LED internal to the key indicates that the Generator is running.

The PAUSE/RESUME key is used to pause the generator, and once paused, and to resume from where the pattern was stopped. The yellow LED internal to the key indicates that the Generator is paused.

Analyzer

The Analyzer box on the front panel contains status and history indicators, that provide operating status at a glance.

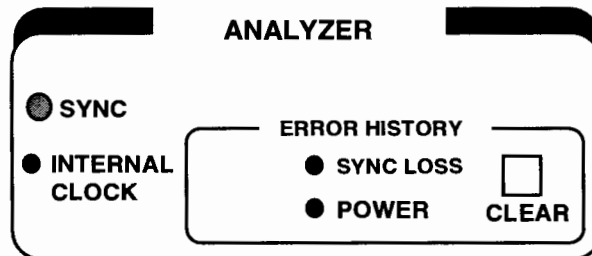

<input type="radio"/> SYNC	When the SYNC LED is lit the unit is considered synchronized, based on the selected sync threshold. See ERROR MODE in Section 4.4.1.
<input type="radio"/> INTERNAL CLOCK	The INTERNAL CLOCK LED is lit when internal Analyzer clock is selected
<input checked="" type="radio"/> SYNC LOSS	The SYNC LOSS LED is lit when the unit is not synchronized, it will remain lit until cleared by the user.
<input checked="" type="radio"/> BIT	The BIT LED is lit when bit errors occurs, and remains lit until it is cleared by the user.
<input checked="" type="radio"/> PHASE	The PHASE LED is lit when the guaranteed setup or hold time of the PB200 input decision circuit is violated. This indicates to the user that the errors that are occurring may be due to input clock/data timing or signal level.
<input checked="" type="radio"/> POWER	The POWER LED is lit when the unit powers up. It remains lit until it is cleared by the user. It is used to indicate that the unit lost power during a long term (overnight) test.

Floppy Drive

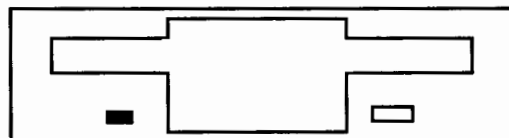

The floppy drive uses 3.5" MS-DOS formatted DS-HD 1.44Mb diskettes. The floppy disk drive can be used to store test results, save test setups and transfer test data to a personal computer for further analysis.

Rear Panel

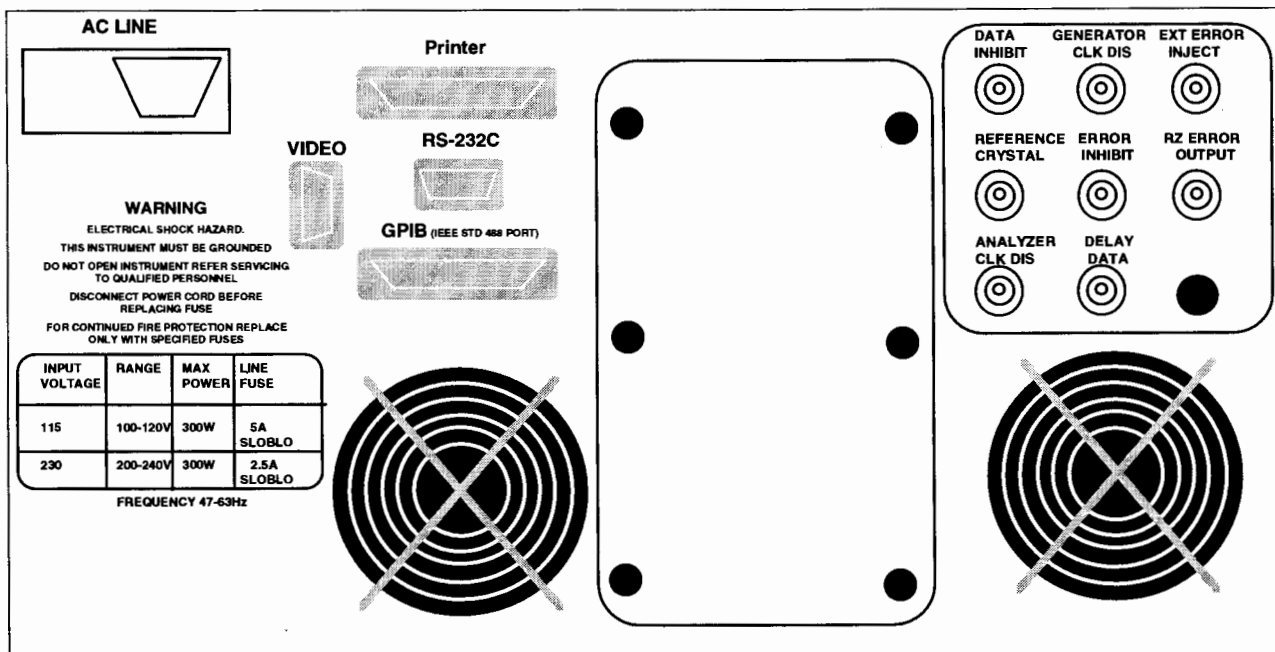

Figure 2-8. Rear Panel - PB200









A BNC connection labeled "External Clock Disable" can be used to gate the Generator clock, either internal or external. The **EXT CLOCK DISABLE** selection enables (**ON**) or disables (**OFF**) the signal from that connector. This signal is combined with the **PAUSE/RESUME** and the **START/STOP** buttons on the front panel, for example, when any of the three controls stop the clock, it is indeed stopped.



The front panel BNC connectors are used for the High speed signal interconnect. All connections should be done using 50 Ohm coaxial cable.

As a general rule, terminate unused outputs with a 50 Ohm impedance.

Note: The same term can be expressed three different ways.

clock = clock bar = NOT clock

<p>EXT CLOCK INPUT</p> 	<p>EXT CLOCK is an input to the Generator. It is selected when the user provides a system clock and bypasses the PB200 internal clock source.</p>
<p>CLOCK</p> 	<p>CLOCK is the true output of the Generator differential clock output. If it is not used, and the user is using CLOCK BAR, it should have a 50 Ohm to GND load. (50 Ohm terminator is provided).</p>
<p>CLOCK</p> 	<p>CLOCK bar (NOT CLOCK) is the inverted output of the Generator differential clock output. If it is not used, and the user is using the CLOCK output, it should have a 50 Ohm to GND load. (50 Ohm terminator is provided)</p>
<p>EXT CLOCK DISABLE</p> 	<p>EXT CLOCK DISABLE. Use this signal to gate the internal clock. (ECL input, 50 Ohm to -2V)</p>
<p>DATA</p> 	<p>DATA is the true output of the Generator differential data output. If it is not used, and the user is using DATA, it should have a 50 Ohm to GND load. (50 Ohm terminator is provided)</p>
<p>DATA</p> 	<p>DATA bar (NOT DATA) is the inverted output of the Generator differential data output. If it is not used, and the user is using the DATA output, it should have a 50 Ohm to GND load. (50 Ohm terminator is provided)</p>
<p>SYNC</p> 	<p>SYNC is provided for data pattern viewing. It is generally connected to the oscilloscope trigger input and used to view bits in the data pattern.</p>
<p>MUX</p> 	<p>MUX is the mixed pattern switching bit. When mixed patterns are used this output is high during overhead bits and low during payload bits.</p>
<p>CLOCK</p> 	<p>CLOCK is the analyzer true input to the differential clock receiver. This input should be used when the user selects differential or single-ended. In single ended mode CLOCK bar is connected to the internal threshold.</p>

<p>CLOCK</p> 	<p>CLOCK bar (NOT CLOCK) is the analyzer invert input to the differential clock receiver. This input is used for differential clock inputs.</p>
<p>DATA</p> 	<p>DATA is the analyzer true input to the differential data receiver. This input should be used when the user selects differential or single-ended. In single ended mode DATA is connected to the internal threshold.</p>
<p>DATA</p> 	<p>DATA bar (NOT DATA) is the analyzer invert input to the differential data receiver. This input is used for differential data inputs.</p>



Changing the Line Fuse

1. Disconnect the AC line cord.
2. Slide the fuse cover upwards and remove the fuse.
3. Install the correct line fuse into the holder.
4. Close the fuse cover.
5. Plug in the line cord.

Allow at least two inches of clearance for the rear panel fan opening and at least one inch of clearance for the top-mounted ventilation slots. This assures proper cooling of the unit. Do not operate the transmitter on its rear side.

AC Line

The AC power input accepts either 115 VAC or 230 VAC. Always use the correct fuse with the voltage supplied, 5A Slo-Blo fuse for 115 VAC, 2.5A Slo-Blo fuse for 230 VAC.

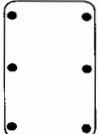
	<p>Video connector A DB-15 pin connector supports a VGA CRT interface .</p>
	<p>Serial Port (RS-232c) A DB-9 pin connector supports the RS-232C interface.</p>
	<p>GPIB connector An IEEE-488.1 standard GPIB connector is provided for GPIB communication.</p>
	<p>Option Panel This panel allows the PB200 to be configured or upgraded with options. Contact the factory for option packages.</p>

Rear Panel BNCs

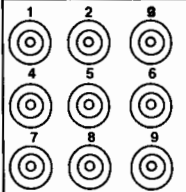

1. Generator Data Inhibit

This is an ECL compatible input, with a 50 Ohm to -2V termination resistor. When it is high it will force the DATA output low and the DATA bar (NOT DATA) output high.

2. Generator Clock Disable

This is an ECL compatible input, with a 50 Ohm to -2V termination resistor. When it is high the INTERNAL clock or the EXTERNAL clock, whichever is being used, is disabled.

3. Generator Error Inject

This is a TTL compatible input. Each rising edge will cause one error to be injected into the data output.

4. Analyzer RZ Error

This is a TTL compatible output. Each error detected by the Analyzer will cause this output to go logic high. Each falling edge of the clock will cause this output to go logic low.

5. Analyzer Error Inhibit

This is an ECL compatible input, with a 50 Ohm to -2V termination resistor. When it is high, it will disable all error counting.

6. Generator Reference Crystal

This is an AC coupled input (.5-2.0Vpp), with a 50 Ohm termination resistor. This input allows the user to provide a 10 MHz reference for the PB200 internal clock source.

7. Analyzer Data Delay

This is a reverse terminated ECL output. It will drive 50 Ohm coax without a termination resistor at the end. This is the received data after it has been delayed through the internal input delay circuit.

8. Analyzer Clock Disable

This is an ECL compatible input, with a 50 Ohm to -2V termination resistor. When this input is high the Analyzer clock is disabled.

9. Blank

Reference

Reference

This chapter describes the PB200 200 Mb/s BERT Transceiver LCD menu structures and displays.

Description	Beginning on page
Menus and Displays	3-2
Generator Menus	3-3
Analyzer Menus	3-14
Menu Maps for both Tx and Rx	3-36
Representative sample of PB200 Applications	3-37

Menus and Displays

GENERATOR					ANALYZER				
CLOCK FREQ	CLOCK FREQ: 205.00000 MHz				CLOCK FREQ: 0.00000 MHz				SLIP CNTRL ENAB
SINGLE ERROR	CLK OUTPUT: 1.00V / -0.50V				ALL ERRORS: 0/0.00E-06				AUTO SEARCH OFF
	DATA OUTPUT: 1.00V / -0.50V				1'S ERRORS: 0/0.00E-06				
SINGLE STEP	DATA PATT: PRBS 7				0'S ERRORS: 0/0.00E-06				EYE WIDTH OFF
	ERROR INJ: OFF				CLK INPUT: 0.00V/GND				
					DATA INPUT: 0.00V/GND/0.00nS				
					DATA PATT: PRBS 7				
CLOCK OUTPUT	DATA OUTPUT	DATA PATTERN	EXT CLOCK	MORE 1 OF 2	CLOCK INPUT	DATA INPUT	DATA PATTERN	AUTO SEARCH	MORE 1 of 3

Figure 3-1. Example of front panel display

The Display is divided into two halves, one side is for the Generator setup, the other side is for Analyzer setup and status measurement data.

The Generator and Analyzer each have their own soft keys, which are labeled around the outside edge of the display.

Pressing a soft key can initiate an action, for example pressing single error will inject a single error, or it can bring up a pop-up window.

When a key is pressed with a pop-up window, that key will reverse video to indicate it is active. It will remain active until either the escape key is pressed or that key is pressed again.

If a second soft key on the other side is pressed while one key is active, it will become the active key, the initial key will show diagonal lines indicating that when the second key becomes inactive again, it will resume the active state.

The pop-up window will do one of the following three functions:

- It will present a value, which can be edited either with the left/right keys and knob, or the numeric keypad and enter key;
- It will present a list of selections to change a current setting; or,
- It will present a list of selections to bring up a lower level pop-up window.

Note: The same term can be expressed three different ways.

clock = clock bar = NOT clock

Generator Softkeys

Clock Frequency

The **CLOCK FREQUENCY** key is used to change the clock frequency. A pop-up window will appear showing the current internal clock frequency. The value can be edited using the **ENTRY** keys.

CLOCK FREQUENCY (value)

The **SINGLE ERROR** key is used to inject a single error into the Data, Data bar output.

The **SINGLE STEP** key is used when the Pattern Generator is **STOPPED** or **PAUSED**. When pressed the Clock Source puts out one pulse, this pulse goes out to the front panel and causes the Pattern Generator to generate the next data bit in the pattern.

Clock Output

The CLOCK OUTPUT key allows the user to vary parameters associated with the Generator Clock/Clock bar outputs.

CLOCK OUTPUT-----
AMPLITUDE (value)
OFFSET (value)
CLOCK GAP ----
ON
OFF

Selecting **AMPLITUDE** allows the user to vary the output amplitude of the clock signal. The amplitude is specified as the voltage difference between the output logic high level and the output logic low level (offset).

Selecting **OFFSET** allows the user to vary the output logic low level. The offset is referenced to ground, hence an offset of -1.00V indicates that the logic low of the clock is one volt below ground.

Selecting **CLOCK GAP** allows the user to turn **ON** or **OFF** the **CLOCK GAP** memory that is used to gate the **CLOCK**. When **"OFF"** the **CLOCK GAP** memory is not used when **"ON"** a one in the **CLOCK GAP** memory enables the **CLOCK**, a zero disables the **CLOCK**.

Data Output

The DATA OUTPUT key allows the user to vary parameters associated with the Generator Data/Data outputs.

DATA OUTPUT ----
AMPLITUDE (value)
OFFSET (value)
DELAY (value)
POLARITY -----
NORMAL
INVERT

Selecting **AMPLITUDE** allows the user to vary the output amplitude of the data signal. The amplitude is specified as the voltage difference between the output logic high level and the output logic low level offset.

Selecting **OFFSET** allows the user to vary the output logic low level. The offset is referenced to ground, hence an offset of -1.00V indicates that the logic low of the data is one volt below ground.

Selecting **DELAY** allows the user to vary the data output delay. This delay is referenced to the Clock bar output rising edge. When the delay is set to zero, the data output transition will be edge aligned with the rising edge of clock output. Negative values indicate that the data is earlier than the clock, positive values indicate that the data is later than the clock.

Selecting **POLARITY** allows the user to switch between normal data output or inverted data output.

Ext Clock

Selecting EXT CLOCK allows the user to switch between the PB200 Internal Clock Source and an External Clock Source. The external clock source is applied to the front panel BNC labeled EXT CLOCK. The EXT CLOCK input 50 Ohm termination voltage and switching threshold can also be changed in this menu.

EXT CLOCK --- 		
EXT CLOCK----- 		
EXT CLOCK TERM----- 		ON
EXT CLOCK THRES (value)	GND	OFF
EXT REF SOURCE----- 	-2V	
EXT CLOCK DISABLE-- 	ON	+3V
	ON	AC
	OFF	

Selecting EXT REF SOURCE turns OFF or ON the rear panel reference crystal input. When "OFF", the INTERNAL CLOCK SOURCE uses its own internal crystal.

Data Pattern

Selecting DATA PATTERN allows the user to change the current data pattern that is being transmitted.

```

DATA PATTERN---|
MODE --> PRBS, MARK, WORD MIXED
PRBS --> PRBS7, PRBS9, PRBS10, PRBS11, PRBS15, PRBS23, PRBS31
PREAMBLE --> ON, OFF
START MODE --> STOP, RUN
LOAD PATTERN *****
STORE PATTERN *****
RECALL PATTERN *****

```

Selecting MODE allows the user to select the type of data pattern to be generated, PRBS, WORD, or MIXED.

Selecting PRBS allows the user to pick one of the internal PRBS codes, as listed above.

Selecting MARK DENSITY allows the user to pick one of the five internal variable density patterns. This is based on PRBS10. Normally in PRBS10, 50% of the data bits are 1's. When MARK DENSITY 1/8 is chosen only 12.5% of the bits will be 1's, and so on.

Selecting PREAMBLE turns off or on the PREAMBLE data generation. When "ON", the generator will send out the preamble data pattern once before it switches to the selected pattern. The selected pattern could be PRBS, WORD, MARK or MIXED. When "OFF", the preamble pattern is not used.

Selecting START MODE allows the user to set the generator to either RUN or STOP. RUN causes the generator to automatically re-start (without pressing the START/STOP key) the pattern generator after changing the pattern. STOP causes the generator to wait until the user presses START/STOP to start the pattern generator after changing a pattern.

Select LOAD PATTERN to load a pattern file with the default (.pat) naming convention from a diskette. See Appendix B "Diskette file format" for diskette file information.

Note: See the Appendix for other information on Loading and Storing Patterns with the PB200.

Select STORE PATTERN allows the user to save data patterns on a floppy diskette.

Select characters for the FILENAME with the twist knob and the left/right arrow keys. Leading and trailing blanks in the filename are ignored. Filenames with an embedded blank are invalid. A maximum of eight characters are permitted in the filename. A three character file extension is automatically added to the filename before the pattern is stored on the floppy diskette.

Select the FILE TYPE of the pattern to write to the floppy diskette. The ALL option will write every generator pattern. The pattern transfer is started when one of the FILE TYPE options is picked.

A scrolling list window has a double line right hand border to distinguish it from displays which do not scroll.

Selecting RECALL PATTERN allows the user to load user-named pattern file(s) into pattern memory. See Appendix B "Diskette file format" for diskette file information.

Note: See the Appendix for other information on Loading and Storing Patterns with the PB200.

Select an item from the FILE TYPE menu to initiate a search for that particular type of generator pattern files on the floppy diskette. The ALL option searches for a complete set of generator patterns. Filenames that match the requested search are presented in the display window for the FILENAME entry.

Select a FILENAME from the scrolling list window to initiate a transfer to pattern memory from diskette. If there are no patterns of the type specified, the scrolling list will show the words "..No.Files..".

MIXED MODE CONTENT

MODE -->PRBS, MARK, WORD

PRBS --> PRBS7, PRBS9, PRBS10, PRBS11, PRBS15, PRBS23, PRBS31

MARK --> MR1/8, MR1/4, MR1/2, MR3/4, MR7/8

Select MIXED MODE CONTENT to choose the contents of the MIXED pattern payload field. This is only used for operating in the MIXED MODE. The payload can be configured to contain a WORD pattern, a PRBS pattern, or one of the MARK patterns.

Select MODE within the MIXED MODE CONTENT submenu to choose either WORD, PRBS, or MARK.

Select PRBS to choose which of the PRBS patterns to use, if PRBS has been selected.

Select MARK to choose which of the MARK RATIO patterns to use, if MARK has been selected.

More

Press MORE to view more of the menu selections that are available on the bottom row of the soft keys.

Sync

Select SYNC to change the pattern sync source. The pattern sync is typically used to view the data bits of a pattern on an oscilloscope. There are three sources to select from.

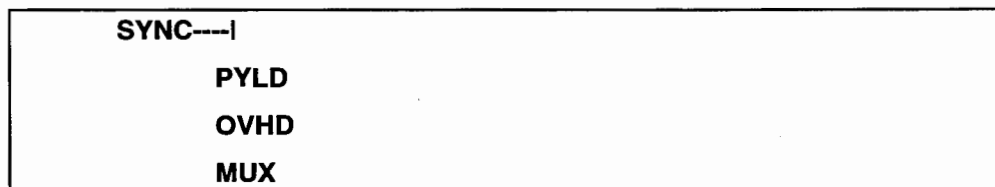

Selecting PYLD brings the pattern sync from the PYLD ram to the front panel BNC. At the beginning of the PYLD RAM it will output a rising edge.*

Selecting OVHD brings the pattern sync from the OVHD ram to the front panel BNC. At the beginning of the OVHD RAM it will output a rising edge.*

Selecting MUX brings the pattern sync from the MUX ram to the front panel BNC. At the beginning of the MUX RAM it will output a rising edge.*

Note: The pulse is generated from the terminal count of the previous RAM cycle, and clocked out by the first bit of the current RAM cycle.

Error Control

Select **ERROR CONTROL** to vary or turn off the generator internal error injection, or to direct the error injection into a selected field.

ERROR CONTROL

ERROR INJECT --> 1E-3, 1E-4, 1E-5, 1E-6, 1E-7, OFF, EXT

ERROR FIELD --> PAYLOAD, OVERHEAD, ALL
--

Select **ERROR INJECT** to vary the internal error inject rate from 1E-3 to 1E-7, to turn internal error inject off, or to enable the rear panel **EXT** error inject input.

Select **ERROR FIELD** to direct the injected errors into either the **PAYLOAD**, the **OVERHEAD** or both fields.

Pattern Edit

Selecting PATTERN EDIT allows the user to edit one of the five patterns that are stored in the generator.

Select PATTERN to choose which of the five patterns to edit. The choices are:

- **PAYLOAD:** This is selected to edit the payload content of a MIXED pattern, or the content of the WORD. Remember that WORD is stored in the payload memory.
- **OVERHEAD:** This is selected to edit the content of the OVERHEAD field in a MIXED pattern.
- **MUX:** This is selected to edit the content of the MUX memory. The MUX memory is used to switch between the PYLD and OVHD fields in a MIXED pattern. A "0" selects data from the PYLD, and a "1" selects data from the OVHD.
- **PREAMBLE:** This is selected to edit the content of the PREAMBLE. This is a pattern that is sent out once before the main pattern is generated.
- **CLOCK GAP:** This is selected to edit the content of the clock gap memory. This memory is used to gate "ON" or "OFF" the clock source. A "1" enables the clock output, while a "0" disables the clock for one clock cycle.

Select BIT ORDER to choose the order of transmission of the bits within each byte. The choices are:

- **MSB:** For each byte, transmit the Most Significant Byte (MSB) first.
- **LSB:** For each byte, transmit the Least Significant Byte (LSB) first.

Select PATTERN EDIT to make changes to the current pattern. If any of the data patterns are currently being edited through a remote interface, the pattern edit cannot be performed from the front panel. If this happens, a message will appear on the top of the screen for 5 seconds, "REMOTE LOCK ON PATTERN EDIT". When the remote edit session ends or the power is cycled, the front panel will again be allowed to edit the data patterns.

EDIT	PATTERN: PAYLOAD			
	LENGTH: 32767	OFFSET: 0		
EXIT/ SAVE	FF FF FF FF FF FF FF	FF	FF	FF
	FF FF FF FF FF FF FF	FF	FF	FF
	FF FF FF FF FF FF FF	FF	FF	FF
	FF FF FF FF FF FF FF	FF	FF	FF
QUIT	FF FF FF FF FF FF FF	FF	FF	FF
	FF FF FF FF FF FF FF	FF	FF	FF
INSERT	DELETE	PG UP	PG DN	PATTERN LENGTH

Figure 3-2. Example of Editing Pattern Payload

Inside the editor, PATTERN identifies the pattern that you are editing and LENGTH gives you the length of the pattern in bytes. OFFSET gives you the location of the cursor based on the number of bytes from the beginning of the pattern. Entries are made via the knob or keypad.

Select EDIT to swap between editors when both the generator and analyzer editors are displayed.

Select EXIT/SAVE to exit the editor and save the changes made.

Select QUIT to exit the editor without saving the changes.

Select INSERT to insert data into the pattern, when INSERT is not in reverse video, entries will overwrite the byte at the cursor.

Select DELETE to delete a byte.

Select PG UP to move up one page in the pattern.

Select PG DN to move down one page in the pattern.

Select PATTERN LENGTH to make changes to the current PATTERN.

PATTERN LENGTH-----	
PATTERN LENGTH	(value)
PATTERN OFFSET	(value)
FILL BYTE	(value)
FILL START OFFSET	(value)
FILL END OFFSET	(value)
FILL PATTERN	(action)

Select PATTERN LENGTH to change the length of the current PATTERN in BYTES.

Pattern Length Ranges (In Bytes)

Payload	2 to 32768
MUX	2 to 32768
Overhead	2 to 32768
Preamble	2 to 2048
Clock gap	2 to 16384

Select PATTERN OFFSET to change the offset into the current PATTERN in BYTES. The offset sets the location of the cursor based on the number of bytes from the beginning of the pattern. The allowed range is from 0 to the end of the pattern, which is 1 less than the length.

Select the FILL BYTE to set the Hexadecimal BYTE used for the FILL function.

Select the FILL START OFFSET to set the offset into the pattern where the FILL will begin. The allowed range is from 0 to the FILL END OFFSET.

Select the FILL END OFFSET to set the offset into the pattern where the FILL will end. The allowed range is from the FILL START OFFSET to the end of the pattern, which is 1 less than the length.

Select FILL PATTERN to actually FILL the current pattern. The selected FILL BYTE will be copied into the pattern from the FILL START OFFSET up to the FILL END OFFSET.

Pattern Copy

Selecting PATTERN COPY allows the user to copy the current Analyzer pattern to the Generator. A pop-up menu will appear when this key is pushed.

Push the ENTER key to display the available patterns to copy to the Analyzer

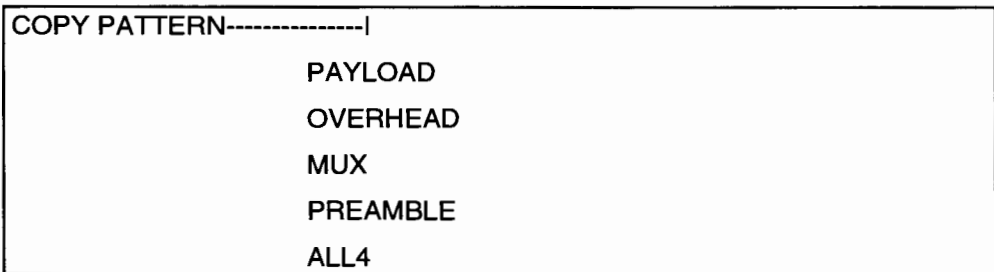

Use the up/down keys to select which pattern to copy. Pushing ENTER executes the copy.

Analyzer Softkeys

Slip Control

Pressing SLIP CNTRL toggles the Analyzer internal pattern slip mechanism. The current state is displayed in the key label in reverse video. This is commonly used when a user is trying to measure very high bit error rates. Once the Analyzer is synchronized, putting the unit in DISAB will prevent the unit from slipping the internal pattern (in an attempt to re-sync) even at BERs up to 100%. The normal condition is ENAB. This key is disabled when AUTO SEARCH is on.

Auto Search

Pressing AUTO SEARCH toggles the operating state of the Auto Search feature. When "ON" the Analyzer automatically sets thresholds, delays and patterns as specified in the AUTO SEARCH key, along the bottom edge of the display.

Eye Width

Pressing EYE WIDTH causes the Analyzer to perform an eye width measurement as specified under the EYE WIDTH soft key located on page 2 of the soft key selections, along the bottom edge of the display (see page 4-16). The eye width will only be measured when AUTO SEARCH is OFF and under one of the following 2 conditions.

1. If the EYE MODE is PHASE, there must be a non-zero frequency;
2. If the EYE MODE is BER, there must be a non-zero frequency and the Analyzer must be in Sync.

The eye width process will be displayed across the top of the display. When the process is complete the eye width will be displayed on the front panel and in the results section of the EYE WIDTH menu.

Note: EYE WIDTH will start and stop the Generator to make measurements.

Clock Input

Selecting **CLOCK INPUT** allows the user to change input parameters associated with the Clock/Clock bar BNC inputs. The pop-up menu selections are as follows:

CLOCK INPUT -----	
CLOCK THRES (value)	SINGLE ENDED
CLOCK TERM -----	DIFFERENTIAL
CLOCK SOURCE ---	GND
INT	-2V
EXT	+3V
	AC

Select **CLOCK INPUT** to change between single ended or differential input. When single ended is used the internal threshold must be set to the center of the input clock signal voltage swing, and the clock bar BNC should be left open.

Select **CLOCK THRES** to vary the input clock threshold when using a single ended clock signal. This should always be set to the center of the input voltage swing to optimize system performance. The threshold will automatically be set when enabled in the **AUTO SEARCH** mode.

Select **CLOCK TERM** to change the input termination voltage. This selects the supply voltage to be connected to the internal 50 Ohm termination resistors at Clock and Clock bar.

Select **CLOCK SOURCE** to switch between the internal Generator to Analyzer clock and/or the front panel clock/clock bar input. When internal clock is selected the front panel clock inputs are not used and the generator clock is automatically connected to the Analyzer internally.

Data Input

Selecting DATA INPUT allows the user to change input parameters associated with the Data/Data bar BNC inputs. The pop-up menus are as follows.

DATA INPUT —	
DATA INPUT -----	
DATA THRES (value)	SINGLE ENDED
DATA TERM -----	DIFFERENTIAL
DESKEW DELAY (value)	GND
DATA POLARITY -	-2V
	NORMAL +3V
	INVERT AC
STARTUP DELAY (value)	

Select DATA INPUT to change between single ended or differential input. When single ended is used the internal threshold should be set to the center of the input data signal voltage swing, and the data bar BNC should be left open.

Select DATA THRES to vary the input data threshold when using a single ended data signal. The threshold will automatically be set when enabled in the AUTO SEARCH mode.

Select DATA TERM to change the input termination voltage. This selects the supply voltage to be connected to the internal 50 Ohm termination resistors at the data and data bar inputs.

Select DESKEW DELAY to change the internal delay that is added to the data input signal path. This delay is referenced to the clock rising edge. The propagation delay from the input BNCs to the decision flip flop is calibrated so that the clock path is 2.5 nS greater than the data path.

This is done so that at the highest operating frequency (200 MHz), if the user edge aligns the clock and data at the BNC inputs the clock rising edge will be in the center of the data bit when the DESKEW DELAY is set to 0nS. And furthermore the unit will sweep the entire operating frequency range without the data edge crossing over the clock edge.

Auto search will set the delay so that the clock rising edge is in the center of the data bit at the decision flip-flop.

Select DATA POLARITY to change between normal and invert.

Select START UP DELAY to change the synchronous start delay in the Analyzer. The maximum value is 65535. This is used to compensate for the D.U.T. propagation delay by delaying the Analyzer pattern generator start a number of clock cycles. For example, if a D.U.T. has a propagation delay of 100nS, at a frequency of 200 MHz, set the startup delay to 20 ($20 \times 5 = 100\text{nS}$). When the pattern is started the Analyzer will wait 20 clocks, then begin looking at the data input.

Note: When not being used, this delay should be set to zero. If the delay is greater than the D.U.T. propagation delay, it could cause synchronization to take a long time.

Data Pattern

Selecting DATA PATTERN allows the user to change the current data pattern that is being used as a reference pattern.

DATA PATTERN---|
MODE --> PRBS, MARK, WORD MIXED
PRBS --> PRBS7, PRBS9, PRBS10, PRBS11, PRBS15, PRBS23, PRBS31
MARK DENSITY
PREAMBLE --> ON, OFF
START MODE -->STOP, RUN
LOAD PATTERN *****
STORE PATTERN *****
RECALL PATTERN *****
MIXED MODE CONTENTS *****

Selecting MODE allows the user to select the type of data pattern, PRBS, WORD, or MIXED.

Selecting PRBS allows the user to pick one of the internal PRBS codes, as listed above.

Selecting MARK DENSITY allows the user to pick one of the five internal variable density patterns. This is based on PRBS10. Normally in PRBS10, 50% of the data bits are 1's. When MARK DENSITY 1/8 is chosen only 12.5% of the bits will be 1's, and so on.

Selecting PREAMBLE turns off or on the PREAMBLE data generation. When "ON", the analyzer will send out the preamble data pattern once before it switches to the selected pattern. The selected pattern could be PRBS, WORD, MARK or MIXED. When "OFF", the preamble pattern is not used.

Selecting START MODE allows the user to set the analyzer to either RUN or STOP. RUN causes the generator to automatically re-start (without pressing the START/STOP key) the pattern generator after changing the pattern. STOP causes the analyzer to wait until the user presses START/STOP to start the pattern analyzer after changing a pattern.

Select LOAD PATTERN to load a pattern file with the default (.pat) naming convention from a diskette. See Appendix B "Diskette file format" for diskette file information.

Note: See the Appendix for other information on Loading and Storing Patterns with the PB200.

Select STORE PATTERN allows the user to save data patterns on a floppy diskette.

Select characters for the FILENAME with the twist knob and the left/right arrow keys. Leading and trailing blanks in the filename are ignored. Filenames with an embedded blank are invalid. A maximum of eight characters are permitted in the filename. A three character file extension is automatically added to the filename before the pattern is stored on the floppy diskette.

Select the FILE TYPE of the pattern to write to the floppy diskette. The ALL option will write every generator pattern. The pattern transfer is started when one of the FILE TYPE options is picked.

A scrolling list window has a double line right hand border to distinguish it from displays which do not scroll.

Selecting RECALL PATTERN allows the user to load user-named pattern file(s) into pattern memory. See Appendix B "Diskette file format" for diskette file information.

Note: See the Appendix for other information on Loading and Storing Patterns with the PB200.

Select an item from the FILE TYPE menu to initiate a search for that particular type of generator pattern files on the floppy diskette. The ALL option searches for a complete set of generator patterns. Filenames that match the requested search are presented in the display window for the FILENAME entry.

Select a FILENAME from the scrolling list window to initiate a transfer to pattern memory from diskette. If there are no patterns of the type specified, the scrolling list will show the words

"..No..Files.."

A scrolling list window has a double line right hand border to distinguish it from displays which do not scroll.

Selecting STORE/RECALL SETUP allows the user to store and recall system setup on the floppy diskette.

Select characters for the STORE NAME with the twist knob and left/right arrow keys. This is the name of the file which will be created to store the current system setups. Leading and trailing blanks in this filename are ignored. Filenames with an embedded blank are invalid. A maximum of eight characters is permitted in the filename. A three character file extension is automatically added to the filename before the setup is stored on diskette.

Select the STORE action to write the current system setup to the floppy diskette. The STORE NAME will be the name of the file containing the current system setup. Select RECALL to initiate a search for system setup files on the floppy diskette. The setup filenames found on the floppy are presented in the display window for the RECALL FILENAME entry.

Select a RECALL FILENAME from the scrolling list window to initiate a transfer to system memory from the diskette, the scrolling list will show the words
"..No..Files..".

Writing a configuration to diskette:

Select characters for the filename with the twist knob and left/right arrow keys. Leading and trailing blanks in the filename are ignored. Filenames with an embedded blank are invalid. A maximum of eight characters are permitted in the filename. A three character file extension (.SRM) is automatically added to the filename before the pattern is stored on diskette.

Then, select the WRITE action to initiate a transfer to floppy diskette.

Reading a configuration from diskette:

Select the READ action to initiate a search for configuration files on the floppy diskette.

Then, select from the scrolling list the name of the file which contain the configuration to be loaded into the system memory.

MIXED MODE CONTENT

MODE -->PRBS, MARK, WORD

PRBS --> PRBS7, PRBS9, PRBS10, PRBS11, PRBS15, PRBS23, PRBS31

MARK --> MR1/8, MR1/4, MR1/2, MR3/4, MR7/8
--

Select MIXED MODE CONTENT to choose the contents of the MIXED pattern payload field. This is only used for operating in the MIXED MODE. The payload can be configured to contain a WORD pattern, a PRBS pattern, or one of the MARK patterns.

Select MODE within the MIXED MODE CONTENT submenu to choose either WORD, PRBS, or MARK.

Select PRBS to choose which of the PRBS patterns to use, if PRBS has been selected.

Select MARK to choose which of the MARK RATIO patterns to use, if MARK has been selected.

Auto Search

Selecting AUTO SEARCH allows the user to selectively enable/disable the individual features of the AUTO SEARCH feature. The user must select the appropriate parameters before enabling AUTO SEARCH. AUTO SEARCH does not affect the Generator (does not restart).

Note: It is important to disable the features that are not needed to keep SYNC time as short as possible.

CLOCK THRESHOLD	ENABLE
DATA THRESHOLD	ENABLE
DELAY	ENABLE
PRBS (PN_7....PN_15)	ENABLE
WORD	ENABLE
MARK	ENABLE
MIXED	ENABLE
POLARITY	ENABLE
TIME	.25
MODE----- 	
	CONTINUOUS SEARCH
	ONCE ONLY
	ONCE/RESTART GENERATOR

Enable **CLOCK THRESHOLD** when the input voltage level at the Analyzer **CLOCK INPUT** is not known. In most cases the **CLOCK INPUT** is set to fixed levels and this is disabled. Set to disable when the Analyzer is using internal clock. Set to disable when using a differential clock. When enabled, the Analyzer will set the threshold to the center of the clock voltage swing.

Enable **DATA THRESHOLD** when the Analyzer data input voltage levels are not known. The Analyzer will set the threshold to the center of the data voltage swing. Set to disable when data is differential.

ENABLE DELAY when the data to clock input timing relationship must be adjusted. The Analyzer will adjust the input data delay so that the clock is sampling the center of the data bit.

Enable **PRBS (PN7...PN15)** when you are using PRBS codes PN7 up to PN15. PN23 and PN31 are not included due to the very long synchronization time when the Generator and Analyzer are not started together.

Note: PN23 and PN31 are not included in the search.

Enable **WORD** when you are using **WORD** patterns.

Enable **MARK** when you are using **MARK** patterns. Each of the five patterns will be tried.

Enable **MIXED** when you are using **MIXED** patterns.

Enable **POLARITY** when the polarity (data or data bar) of the incoming data is not known.

TIME allows the user to specify how long the Analyzer spends attempting to synchronize on each pattern. It is the time it takes to synchronize on a pattern, based on several factors. Some of these factors can only be approximated. The following is a guideline.

1. The longer the pattern, the longer the sync time.
2. The lower the required **SYNC THRESH** error rate, the longer the sync time, because it takes longer to get the errors.
3. The lower the frequency, the longer the sync time.

Use the following equation to approximate the time to synchronize to a pattern.

$$ST = (CS*B)*1/F$$

where:

ST is the time to synchronize, in seconds.

CS is the number of Clock Slips required to align the analyzer with the incoming data pattern.

B is the average number of Bits it will take to get the number of errors (specified by the selected SYNC THRESH) due to the incoming data pattern being misaligned with the Analyzer pattern.

Level	SYNC Threshold	# Errors Required
1	2.5E-1	256
2	6.3E-2	256
3	1.6E-2	128
4	3.9E-3	128
5	9.8E-4	64
6	2.4E-4	64
7	6.1E-5	64
8	1.5E-5	64

F is the operating frequency.

EXAMPLE 1:	Pattern:	PRBS15
	Sync. Thresh:	2.5E-1
	Frequency:	100 MHz

CS: For PRBS 15 there are $2E^{15}-1$ bits = 32767. This assumes the worst case of having to slip through the whole pattern.

B: Since the SYNC THRESH is 2.5E-1, it will take 256 errors to slip. When PRBS patterns are misaligned the error rate is 50%, therefore it will take an average of 512 bits to get 256 errors.

$$ST = (32767*512)*1/100E6 = .168 \text{ seconds}$$

EXAMPLE 2:	Pattern:	Mixed-----	PYLD - PRBS7
			OVHD - 50 bytes
			MUX - 53 bytes
	Sync. Thresh:	2.5E-1	- 5 bytes of OVHD
	Frequency:	155 MHz	- 48 bytes of PYLD

CS: Each MUX frame looks at 5 bytes of OVHD then 48 bytes of PYLD. It will take 10 MUX frames to repeat the OVHD. It will take 381 MUX frames to repeat the PYLD. It will take 3810 (381*10) MUX frames for the pattern to repeat. Each MUX frame is 53 bytes, therefore the worst case CS is 1615440 bits.

B: Since most of the pattern is PRBS, the misaligned error rate is probably close to 50%, lets assume its around 30%. This means we can use the 25% SYNC THRESH. Therefore it will take 256 errors/.3 = 854 bits to get 256 errors.

$$ST = (1615440*854)*1/155E6 = 8.9 \text{ seconds}$$

EXAMPLE 3: Repeat EXAMPLE 2 except set the Analyzer to look at PAYLOAD only.

CS: Stays the same, 1615440.

B: Since we are only looking at PYLD, we can use 50% instead of 30%, therefore it will take 512 (256/.5) bits to get 256 errors. Since we are only using 48 of every 53 bytes, it will take 566 bits to get 256 errors.

$$ST = (1615440*566)*1/155E6 = 5.9 \text{ seconds.}$$

MODE allows the user to change the function of the Auto Search feature so that it is optimum for his test environment.

CONTINUOUS SEARCH: When in this mode, the Analyzer will repeatedly go through the enabled Auto Search features whenever the Analyzer goes out of SYNC. It will not stop searching until it gains SYNC. The message bar will display "searching . . ." while it is searching.

The main advantage using this mode is that it leaves Auto Search activated so you never have to do anything to initiate the search. The disadvantage is that if you are using PN23 or PN31 or a long programmable pattern, it may never SYNCHRONIZE, and it may take you a while to realize it.

ONCE ONLY: When in this mode, the Analyzer will go through the enabled Auto Search features only once. It will then exit Auto Search, regardless of SYNC. The message bar will display "searching . . . ONCE ONLY" while searching.

The main advantage using this mode is that it does the Auto Search once, so the user knows immediately that the Analyzer will not synchronize to the pattern, something in the Auto Search features must be enabled, or the pattern must be

manually selected or the pattern must be restarted. The disadvantage is that you must initiate each Auto Search.

ONCE/RESTART GENERATOR: When this mode is used, the Analyzer stops and starts the Generator before each pattern is tried. This will speed up synchronization in most cases, however, it will stop the flow of data from the Generator momentarily during the restart. The message bar will display "searching . . . ONCE/RESTART GEN" while searching.

The main advantage of this mode is that if you have a pattern that is so long that it will not synchronize within the time limit of 10 seconds, using this mode, the Generator and Analyzer are restarted synchronously so that the Analyzer only has to compensate for the D.U.T. propagation delay. Use this mode when you are using PN23 or PN31, however, be sure to disable the PRBS, MARK, WORD, MIXED features in the Auto Search menu. Manually select the PN in both the Generator and Analyzer. Pushing Auto Search will then automatically set the thresholds, delay, polarity, and bit alignment.

More

Press MORE to view more of the menu selections available along the bottom edge of the display.

Eye Width

Press EYE WIDTH to change the parameters used to measure the eye width, or to view the eye width results.

EYE WIDTH
EYE MODE --> BER, PHASE
SAMPLES --> 1E3, 1E4, 1E5, 1E6, 1E7, 1E8, 1E9, 1E10, 1E11
THRESHOLD #1 --> 1E-2, 1E-3, 1E-4, 1E-5, 1E-6, 1E-7, 1E-8, 1E-9, 1E-10
EXTRAPOLATION --> ON, OFF
THRESHOLD #2 --> 1E-2, 1E-3, 1E-4, 1E-5, 1E-6, 1E-7, 1E-8, 1E-9, 1E-10
THRESHOLD #3 --> 1E-6, 1E-7, 1E-8, 1E-9, 1E-10, 1E-11, 1E-12, 1E-13, 1E-14, 1E-15, 1E-16
RESULTS (submenu)

Select EYE MODE to change between PHASE and BER method of eye measurement. PHASE mode uses the PB200 data transition circuit to search for the data transition region. Synchronization is not required so this is a very fast method of measuring the eye width. No other parameters are required. BER mode measures the eye width based on the selected bit error rate.

Select SAMPLES to change the number of bits contained in each BER eye measurement. This should be low to minimize the time to do a BER eye width, but high enough to give the user confidence in the measurement. Typically if the BER eye measurement is for 1E-7, then the samples would be set to 1E8, this allows for 10 errors/measurement.

Select THRESHOLD #1 to set the eye width measurement BER. This is the only threshold necessary when Extrapolation is OFF. When Extrapolation is ON this is the first (highest BER) threshold used for BER Extrapolation. (see the figure on the next page - Extrapolated Eye Measurement).

Select EXTRAPOLATION to enable or disable the extrapolation feature. Extrapolation is used to save time to get the eye width at very low error rates. It does this by measuring the eye width at 2 high error rates and using a log approximation extrapolating to the desired low BER eye width (see figure below). Thresholds 2 and Threshold 3 must be specified.

Select THRESHOLD #2 to set the second measured BER threshold for Extrapolation (see figure below).

Select THRESHOLD #3 to set the desired BER EYE WIDTH threshold when using EXTRAPOLATION (see figure below).

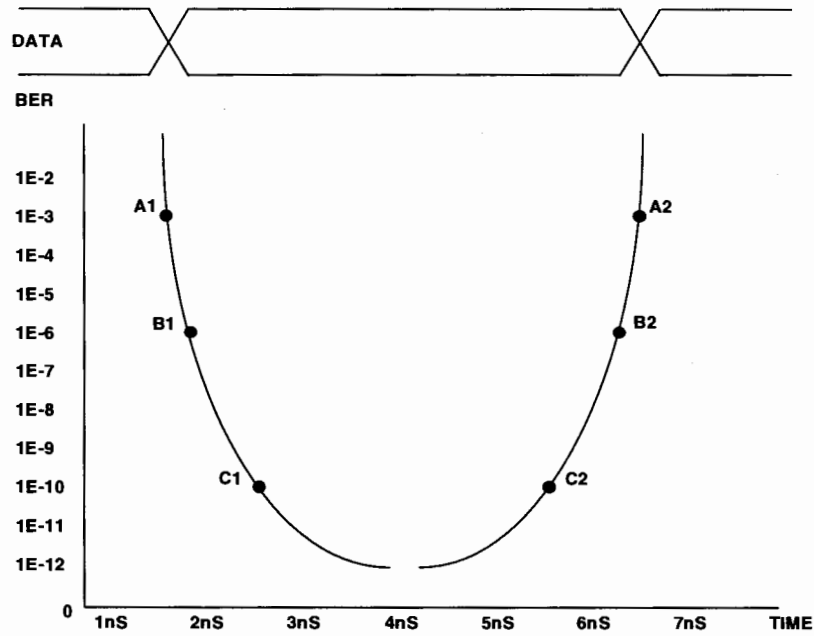

Figure 3-3. Extrapolated Eye Measurement

Threshold #1 measured at A1 and A2

Threshold #2 measured at B1 and B2

Threshold #3 (desired value) calculated to be at C

EXTRAPOLATED EYE WIDTH = C2-C1

Select RESULTS ... to view the eye width results.

	Status:	Success
	Eye Width:	8340 pS
	Left	Right
#1	12560 pS	20980 pS
#2	12580 pS	20980 pS
#3	12580 pS	20980 pS

Status indicates whether the Analyzer was able to measure or calculate the eye width. The value in parentheses indicates how the value was arrived at.

EYE WIDTH gives the value of the eye width measurement or calculation.

The table of values are the points (A1-C2, see figure - Extrapolated Eye Measurement.) measured at the 3 BER eye width thresholds.

Error Mode

Select ERROR MODE to change the field over which errors are being counted, and the criteria used to determine the IN SYNC/OUT OF SYNC condition.

ERROR MODE--	
ERROR MODE-----	
SYNC THRES----	PYLD
2.5E-1	OVHD
6.3E-2	ALL
1.6E-2	
3.9E-3	
9.8E-4	
2.4E-4	
6.1E-5	
1.5E-5	

Selecting PYLD causes the Analyzer to count errors that occur only during the PYLD bits, OVHD only during the OVHD bits, and ALL counts all errors (during both).

Selecting SYNC THRES allows the user to change the SYNC threshold. This is the error rate that the Analyzer will use to determine whether or not it is synchronized to the incoming data pattern.

Selecting a high error rate 2.5E-1 will allow error rates up to 25% before the Analyzer slips its internal generator in an attempt to synchronize with the received data.

Selecting a lower rate, will cause the unit to attempt to gain sync (clock slip) at lower error rates. This is required when an error free data pattern that is misaligned (not synchronized) results in an error rate that is less than 25%.

The rate you chose depends on what that error rate could be. Select the highest rate that is below the lowest error rate possible when error free data is misaligned. This will result in the most robust tolerance to errors without the risk of false framing.

Pattern Edit

Selecting PATTERN EDIT allows the user to edit one of the five patterns that are stored in the analyzer.

PATTERN EDIT----- 		
PATTERN----- 		
BIT ORDER----- 		PAYLOAD
PATTERN EDIT (submenu)	MSB	OVERHEAD
	LSB	MUX
		PREAMBLE

Select PATTERN to choose which of the five patterns to edit. The choices are:

PAYLOAD: This is selected to edit the payload content of a MIXED pattern, or the content of the WORD. Remember that WORD is stored in the payload memory.

OVERHEAD: This is selected to edit the content of the OVERHEAD field in a MIXED pattern.

MUX: This is selected to edit the content of the MUX memory. The MUX memory is used to switch between the PYLD and OVHD fields in a MIXED pattern. A "0" selects data from the PYLD, and a "1" selects data from the OVHD.

PREAMBLE: This is selected to edit the content of the PREAMBLE. This is a pattern that is sent out once before the main pattern is generated.

Select BIT ORDER to choose the order of transmission of the bits within each byte. The choices are:

MSB: For each byte, transmit the Most Significant Byte (MSB) first.

LSB: For each byte, transmit the Least Significant Byte (LSB) first.

Select PATTERN EDIT to get into the pattern editor once you have selected the pattern to edit. If any of the data patterns are currently being edited through a remote interface, the pattern edit cannot be performed from the front panel. If this happens, a message will appear on the top of the screen for 5 seconds, "REMOTE LOCK ON PATTERN EDIT". When the remote edit session ends or the power is cycled, the front panel will again be allowed to edit the data patterns.

EDIT	PATTERN: PAYLOAD LENGTH: 32767 OFFSET: 0			
EXIT/ SAVE	FF FF FF FF FF FF FF	FF FF FF FF FF FF FF	FF FF FF FF FF FF FF	FF FF FF FF FF FF FF
	FF FF FF FF FF FF FF	FF FF FF FF FF FF FF	FF FF FF FF FF FF FF	FF FF FF FF FF FF FF
	FF FF FF FF FF FF FF	FF FF FF FF FF FF FF	FF FF FF FF FF FF FF	FF FF FF FF FF FF FF
QUIT	FF FF FF FF FF FF FF	FF FF FF FF FF FF FF	FF FF FF FF FF FF FF	FF FF FF FF FF FF FF
INSERT	DELETE	PG UP	PG DN	PATTERN LENGTH

Figure 3-4. Example of Editing Pattern Payload

Inside the editor, **PATTERN** identifies the pattern that you are editing and **LENGTH** gives you the length of the pattern in bytes. **OFFSET** gives you the location of the cursor based on the number of bytes from the beginning of the pattern. Entries are made via the knob or keypad.

Select **EDIT** to swap between editors when both the generator and analyzer editors are displayed.

Select **EXIT/SAVE** to exit the editor and save the changes made.

Select **QUIT** to exit the editor without saving the changes.

Select **INSERT** to insert data into the pattern, when **INSERT** is not in reverse video, entries will overwrite the byte at the cursor.

Select **DELETE** to delete a byte.

Select **PG UP** to move up one page in the pattern.

Select **PG DN** to move down one page in the pattern.

Select PATTERN LENGTH to make changes to the current PATTERN.

PATTERN LENGTH-----	
PATTERN LENGTH	(value)
PATTERN OFFSET	(value)
FILL BYTE	(value)
FILL START OFFSET	(value)
FILL END OFFSET	(value)
FILL PATTERN	(action)

Select PATTERN LENGTH to change the length of the current PATTERN in BYTES.

Pattern length ranges (in bytes)

Payload	2 TO 32768
MUX	2 TO 32768
Overhead	2 TO 32768
Preamble	2 TO 2048
Clock gap	2 To 16384

Select PATTERN OFFSET to change the offset into the current PATTERN in BYTES. The offset sets the location of the cursor based on the number of bytes from the beginning of the pattern. The allowed range is from 0 to the end of the pattern, which is 1 less than the length.

Select FILL BYTE to set the Hexadecimal BYTE used for the FILL function.

Select the FILL START OFFSET to set the offset into the pattern where the FILL will begin. The allowed range is from 0 to the FILL END OFFSET.

Select the FILL END OFFSET to set the offset into the pattern where the FILL will end. The allowed range is from the FILL START OFFSET to the end of the pattern, which is 1 less than the length.

Select FILL PATTERN to actually FILL the current pattern. The selected FILL BYTE will be copied into the pattern from the FILL START OFFSET up to the FILL END OFFSET.

Pattern Copy

Selecting PATTERN COPY allows the user to copy the current Generator pattern to the Analyzer. A pop-up menu will appear when this key is pushed.

Push the ENTER key to display the available patterns to copy to the Analyzer

```
COPY PATTERN-----|
                    |
                    |      PAYLOAD
                    |      OVERHEAD
                    |      MUX
                    |      PREAMBLE
                    |      ALL4
                    |
```

Use the up/down keys to select which pattern to copy. Pushing ENTER executes the copy.

Sliding Window

Selecting **SLIDING WINDOW** allows the user to modify the parameters for the sliding window data measurements. The sliding window measurements present the data results that occurred during the prior time specified or the previous number bits as specified. The period being examined will slide along over time. The pop-up menu selections are as follows:

SLIDING WINDOW-----		
WINDOW MODE-----		
TIME LEN (value)		BITS
BITLENGTH (value)		SEC
END-OF-WINDOW REPORT-----		
DATA DISPLAY MODE-----		ON
	WINDOW	OFF
	TOTALIZE	

Select **WINDOW MODE** to change between a window length based on seconds or bits. When bits is selected, the window measurements will be based on the number of bits specified by **BIT LENGTH**. When sec is used, the window length will be in terms of seconds as specified in **TIME LEN**.

Select **TIME LEN** to change the sliding window length for the mode of **SEC**. The times allowed range from 1 second (00:00:01) to nearly 24 hours (23:59:59).

Select **BIT LENGTH** to change the sliding window length for the mode of **BITS**. The window length can range from 1e08 to 1e16. The corresponding length in time will depend on the received clock frequency. There will be an overall minimum length of 1 second.

Select **END-OF-WINDOW REPORT** to allow measurement reports to be printed at the end of each window. For example, for a 10 second window there would be a printout every 10 seconds. Refer to Appendix H for an example of an end-of-window report.

Select **DATA DISPLAY MODE** to change measurements displayed on the front panel. The default **TOTALIZE** data results display data accumulated since the last Error History **CLEAR** key press. Use **WINDOW** to display the window measurements on the front panel. When **WINDOW** is selected, an extra line on the front panel may appear, "MEAS LEN", which displays the current length of the sliding window in bits and seconds.

Test Control

Selecting TEST CONTROL allows the user to modify the parameters for the TEST data measurements. The test parameters control the way the testing will be run. The pop-up menu selections are as follows:

TEST CONTROL
<TEST START/STOP>
TEST LEN (value)
TEST MODE --> Untimed, Timed Repeat
ERROR THRESHOLD (value)
ON ERROR SQUELCH --> ON, OFF
TEST REPORT --> None, On error, End of test, Both
<PRINT TEST RESULTS>

Select < TEST START / STOP > to start or stop a test. This will toggle the current test state. When the test is running, a message will appear on the top of screen, for example "TIMED TEST IN PROGRESS"

Select TEST LEN to change the length of the test. This controls when the test will automatically end when in TIMED or REPEAT mode. The test length can range from 1 second (00:00:01) to nearly 24 hours (23:59:59).

Select TEST MODE to change the timing mode of the test. Using the mode TIMED, tests will run for the duration specified under TEST LEN and then stop, unless manually stopped. Using REPEAT mode, the TIMED test will restart after the automatic end, until it is finally manually stopped. Using the UNTIMED mode, the test will run indefinitely, until it is manually stopped.

Select ERROR THRESHOLD to change the Test Error Threshold. This threshold is the error rate threshold used for Threshold Error Seconds and is used to determine when to print On Error reports (when the error rate for the second exceeds the Test Error Threshold). The range for this threshold is from 1e-02 to 1e-10.

Select TEST REPORT to control the automatic test reports. Reports can be printed at the end of the test and/or whenever the error rate exceeds the test error threshold during the test.

Select < PRINT TEST RESULTS > to print the end-of-test report. This will print the report for the currently running test, if there is one. Otherwise, it will print the end-of-test report for the previously run test. If no test has been run since the unit has been turned on, nothing will be printed.

Test Results

Selecting TEST RESULTS will display the latest test results. If a test is currently running, these results will show the data from the currently running test. Otherwise the results displayed will be from the previously run test. If no test has been run since the unit has been turned on, nothing will be displayed.

Menu Maps

The following table lists all the menu, and submenu, choices available from the PB200.

<p>PB200 - Generator</p> <ul style="list-style-type: none"> Clock Frequency Single Error Single Step Clock Output <ul style="list-style-type: none"> Amplitude, Offset, Clock Gap Data Output <ul style="list-style-type: none"> Amplitude, Offset, Delay, Polarity Data Pattern <ul style="list-style-type: none"> Mode, PRBS, Preamble, Start Mode, Load Pattern, Store Pattern, Recall Pattern Ext Clock <ul style="list-style-type: none"> Ext Clock, Ext Clock Term, Ext Clock Threshold, Ext Clock Source, Ext Clock Disable SYNC <ul style="list-style-type: none"> Payload, Overhead, MUX Error Control <ul style="list-style-type: none"> Error Inject, Error Field Pattern Edit <ul style="list-style-type: none"> Pattern, Bit Order Pattern Copy <ul style="list-style-type: none"> Payload, Overhead, MUX, Preamble, ALL4 	<p>PB200 - Analyzer</p> <ul style="list-style-type: none"> Slip control Clock Input <ul style="list-style-type: none"> Clock Input, Clock Threshold, Clock Term, Clock Source Data Input <ul style="list-style-type: none"> Data Input, Data Threshold, Data Term, Input Delay, Data Polarity, Startup Delay Data Pattern <ul style="list-style-type: none"> Mode, PRBS, Preamble, Start Mode, Load Pattern, Store Pattern, Recall Pattern Auto Search <ul style="list-style-type: none"> Clock Threshold, Data Threshold, Delay, PRBS, Word, Mark, Mixed, Polarity, Time, Mode Eye Width <ul style="list-style-type: none"> Eye Mode, Samples, Threshold #1, Extrapolation, Threshold #2, Threshold #3, Results Error Mode <ul style="list-style-type: none"> Error Mode, SYNC Threshold Pattern Edit <ul style="list-style-type: none"> Pattern, Bit Order, Pattern Edit Pattern Copy Sliding Window <ul style="list-style-type: none"> Window Mode, Time Length, Bit Length, End-of-Window Report, Data Display Mode Test Control <ul style="list-style-type: none"> Test Start/Stop, Test Length, Test Mode, Error Threshold, On Error Squelch, Test Report, Print Test Results Test Results
--	---

Applications

PB200 Satellite Test & Simulation

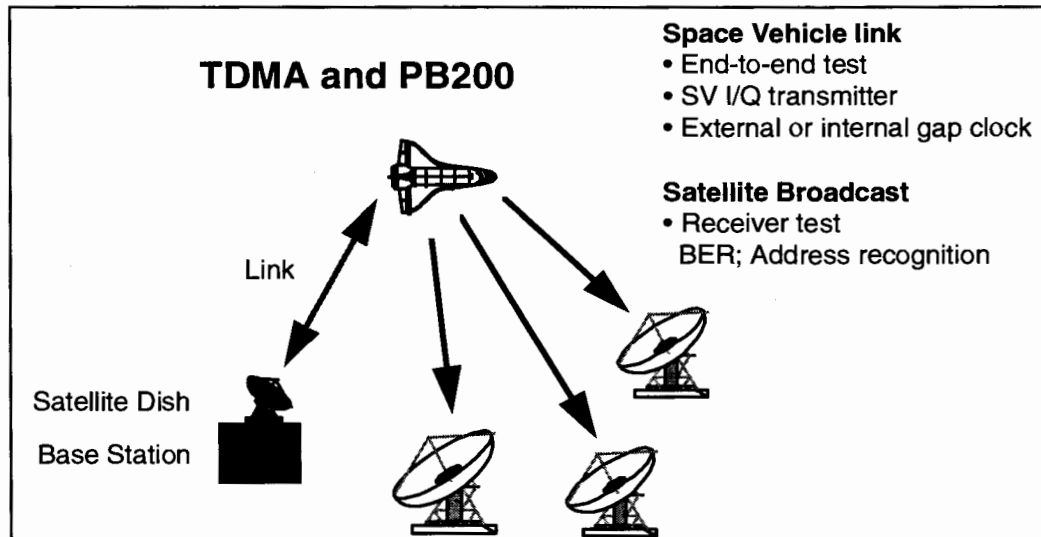

One of the applications uniquely suited to the PB200 is satellite communications test and simulation. These benefit from the PB200's *burst capability*; which permits long periods of time to elapse between data; its *clock gap* ability that provides for internal gating to simulate data bursts; its *two channel output* to drive both rails of an I/Q modulator independently; and, its ability to generate and distinguish *overhead (address) bits and payload bits*.

The picture above illustrates two examples of TDMA communications. With TDMA, the customer may derive a trigger delayed from "live" data bursts and insert test data into an active system's idle time slot.. At the left you see a ground station in communication with a space vehicle. Companies are using the PB200 in their lab to simulate up and down link communications, and to replace the Space Vehicle's transmissions for receiver analysis.

At the right, imagine the Space Vehicle has been replaced with a satellite for video broadcast. The PB200 can replicate an MPEG data stream, and can be used at receiver sites to verify address recognition and error rate performance.

The PB200 is a bit-error-rate tester with unique features not found in traditional BERTs. Two separate programmable word memories 256K bits in length allow the construction of a packet or cell that can consist of user definable preamble, overhead, and data. The PB200 can also function as a fully featured non-packetized BERT. The PB200 is focused at the research, design, and manufacturing of telecommunication components, modules, or links operating at data rates up to 200 Mbit/s.

Basic BERT testing with the PB200

A critical element in digital transmission systems is how error-free its transmissions are. This measurement is made by a bit-error-rate tester (BERT). The PB200 BERT Transceiver provides BERT measurements at bit rates from DC to 200 Mb/s using either PRBS or User Defined Patterns (up to 256 Kbit deep).

Understand instrument setup for BERT testing using PRBS patterns. This lab checks the basic functionality of the PB200. You will reset unit to factory defaults, setup PRBS patterns for both Generator (Tx) and Analyzer (Rx), check for error free measurements, insert bit errors, and change generator frequencies.

This lab programs the PB200 Generator to provide PRBS clock and data signals for the Analyzer. Using AUTO-SEARCH features, the Analyzer will synchronize to the incoming PRBS test pattern. Bit Error Rate (BER) measurements will be performed on both good (fault-free) and bad (used injected faults) data streams.

As a general rule, terminate unused outputs with a 50 Ohm impedance.

This application example demonstrates the use of AUTO-SEARCH Synchronization.

Equipment Required

Description	Qty	Part Number	Source
PB200 Transceiver	1	PB200	Tek
50Ω Coax BNC cables, 18" length, male to male (any equal length quality BNC cable will work)	2	012-0076-00	Tek
50Ω BNC terminators (any quality 50Ω terminator will work)	2	46650-51	Amphenol

Potential Operator Problems

- Connecting the Generator's CLOCK output to the Analyzer's NOT-CLOCK (clock-bar) input
- Connecting the Generator's data output to the Analyzer's not-data (data-bar) input
- Changing Generator's CLOCK amplitude/offset when the application example calls for adjustments to DATA signals

Instrument Connections and Controls:

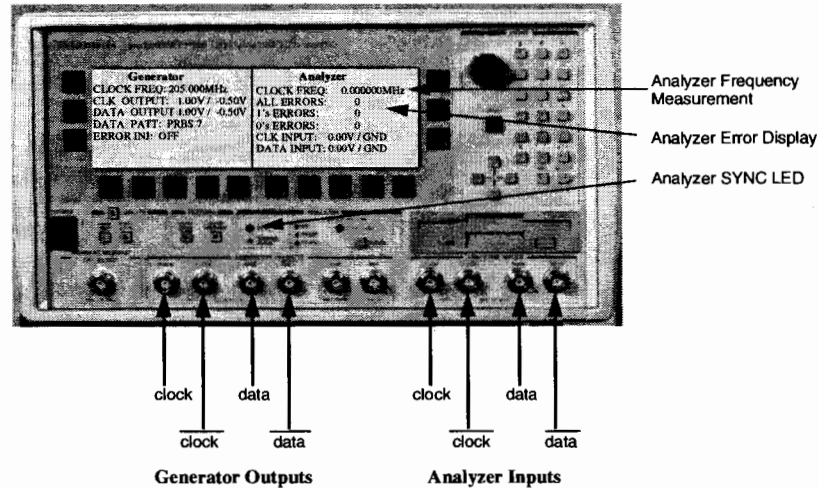

1. Connect the Generator to the Analyzer as shown below.

GENERATOR		ANALYZER
generator clock output	⇒	analyzer clock input
generator n_clock output	⇒	50Ω terminator
generator data output	⇒	analyzer data input
generator n_data output	⇒	50Ω terminator

2. Power up and reset unit.

Power up the unit.

Press the “UTILITY” key (near power switch). This will bring up the UTILITY menu.

Press the soft key “FACTORY DEFAULT”.

Press the “ENTER” key (below the rotary knob). Press the down arrow key so that YES is in reverse video.

Press the key “ENTER” to perform the default reset.

Press the soft key “UTILITY” to remove the utility submenu.

3. Setup Generator for PRBS-7 Mode.

On the GENERATOR window, press the soft key "DATA PATTERN". Setup the generator for PRBS transmission with PRBS-7 data pattern. To operate and select menu items, use the arrow keys ($\leftarrow \uparrow \downarrow \rightarrow$) followed by the ENTER key. The DATA PATTERN menu should look like the following:

GENERATOR	
DATA PATTERN	
MODE	PRBS
PRBS	PRBS 7
MARK DENSITY	MARK RATIO 1/2
PRE-AMBLE	OFF
START MODE	STOP
LOAD PATTERN ...	
STORE PATTERN ...	
RECALL PATTERN ...	
MIXED MODE CONTENTS ...	

Press the soft key "DATA PATTERN" when complete. This will remove the menu.

4. Setup Analyzer for PRBS 7 mode.

On the ANALYZER window, press the soft key "DATA PATTERN". Setup the generator for PRBS transmission with PRBS-7 data pattern. To operate and select menu items, use the arrow keys ($\leftarrow \uparrow \downarrow \rightarrow$) followed by the ENTER key. The DATA PATTERN menu should look like the following:

ANALYZER	
DATA PATTERN	
MODE	PRBS
PRBS	PRBS 7
MARK DENSITY	MARK RATIO 1/2
PRE-AMBLE	OFF
LOAD PATTERN ...	
STORE PATTERN ...	
RECALL PATTERN ...	
MIXED MODE CONTENTS ...	
STORE/RECALL SETUP ...	

Press the soft key "DATA PATTERN" when complete. This will remove the menu.

5. Start the Generator

Press the pattern key “**START/STOP**” (*pattern keys are located to the right of the utility keygroup*). The LED inside the **START/STOP** key will light.

Press the error history key “**CLEAR**” (*error history keys are located in the analyzer keygroup*). All of the Analyzer Error History LED’s should clear (turn off). The Analyzer display should look as follows:

ANALYZER				SLIP CTRL
CLOCK FREQ:	205.000 MHz ($\pm 5\%$)			ENAB
ALL ERRORS:	0 / 0.00E-08			AUTO
1’S ERRORS:	0 / 0.00E-08			SEARCH
0’S ERRORS:	0 / 0.00E-08			OFF
CLK INPUT:	0.00V / GND			EYE
DATA INPUT:	0.00V / GND / 0.000nS			WIDTH
DATA PATT:	PRBS 7			OFF
CLOCK INPUT	DATA INPUT	DATA PATTERN	AUTO SEARCH	MORE... 1 OF 3

6. Check for Error Free Operation

Check for error free operation of the unit. You should notice the **SYNC** active (**SYNC LED ON**), no Errors, and Analyzer frequency measurement accurate to within 5%.

STOP and then **START** unit. Again check for error free operation of the unit.

Disconnect the **DATA** cable at the Analyzer input. Notice what happens. Re-connect the **DATA** cable to the Analyzer **DATA** input and press the error history key “**CLEAR**”. Unit should now be error free.

Disconnect the **CLOCK** cable at the Analyzer input. Notice what happens. The unit’s factory reset condition utilizes an internal clock connection between Generator and Analyzer. No clock cable is required for this mode of operation. Re-connect the **CLOCK** cable to the Analyzer **CLOCK** input.

7. Change Analyzer to External Clock

On the ANALYZER window, press the soft key “CLOCK INPUT”. Scroll down to the CLOCK SOURCE selection and press the “ENTER” key. Press the down arrow key so that EXT is in reverse video. Press the key “ENTER” to perform the action . This will select the external (i.e. front panel) clock as the input to the Analyzer.

On the ANALYZER window, press the soft key “CLOCK INPUT” to remove the menu.

Check for error free operation of the unit. You should notice the SYNC active, no Errors, and Analyzer frequency measurement accurate to within 5%. The INTERNAL CLOCK LED should now be turned off.

STOP and then START unit. Again check for error free operation of the unit.

Disconnect the CLOCK cable at the Analyzer input. Notice what happens. Re-connect the CLOCK cable to the Analyzer CLOCK input and press the error history key “CLEAR”. Unit should now be error free.

8. Inject an Error

On the GENERATOR window, press the soft key “SINGLE ERROR” one time. This will inject one error into the Generator Data output. You should notice the following:

- Analyzer display “Errors” will count 1
- Error Rate will change to something other than 0
- The Error History “BIT” LED will illuminate.
- Either the 1’s or the 0’s error display will also have counted the injected error - this depends on whether the error was injected on an outgoing one or zero in the pattern

Now press the soft key “SINGLE ERROR” several times and watch the error count increase.

Press the error history key “CLEAR” and confirm error free operation of the unit.

9. Change the Generator Frequency

On the GENERATOR window, press the soft key “CLOCK FREQ”. A pop-up window will appear indicating the frequency that the generator is currently set to. To change this frequency, enter the new value on the numeric keypad and press the “ENTER” key. You can also change this value using the left/right arrow keys to select resolution and the front panel knob to increase or decrease the clock frequency.

Notice that the ANALYZER *clock frequency changes* according to the generator output.

Notice that the ANALYZER *never loses synchronization*. The PB200 unit has **phase-synchronous clock and data edge tracking**. After edges are aligned, they will track each other. This is an important time-saving feature for any application involving BER vs. FREQUENCY and a significant competitive advantage in some applications.

Mixed Mode Patterns with the PB200

A critical element in digital transmission systems is how error-free its transmissions are. This measurement is made by a bit-error-rate tester (BERT). The PB200 BERT Transceiver provides BERT measurements at bit rates from DC to 200 Mb/s using either PRBS or User Defined Patterns (up to 256 Kbit deep).

Load a mixed mode pattern to simulate BERT testing with packet data structures. A simple MPEG2 packet will be loaded from floppy disk. Packet files will include minimum overhead and payload information to simulate an MPEG 2 transport stream. BER Errors will be inserted in this mixed mode packet.

This application example programs the PB200 Generator and Analyzer for Mixed Mode operation. A packet structure is loaded into memory and mixed mode operation is selected. Bit Error Rate (BER) measurements will be performed on good and bad (used injected faults) data streams. Difficulties synchronizing the mixed mode pattern are expected, and adjustments to error mode sync threshold will be made.

As a general rule, terminate unused outputs with a 50 Ohm impedance.

This application example demonstrates the use of MIXED MODE and RECAL PATTERN operation.

Equipment Required:

Description	Qty	Part Number	Source
PB200 Transceiver	1	PB200	Tek
50Ω Coax BNC cables, 18" length, male to male (any equal length quality BNC cable will work)	2	012-0076-00	Tek
50Ω BNC terminators (or equivalent)	2	46650-51	Amphenol
floppy disk with mpeg2_v2 pattern files	1	xxx-xxxx-xx	

Potential Operator Problems

- Connecting the Generator's CLOCK output to the Analyzer's NOT-CLOCK (clock-bar) input
- Connecting the Generator's DATA output to the Analyzer's NOT-DATA (data-bar) input
- Failure to setup mixed mode contents to same PRBS patterns on Generator and Analyzer

Instrument Connections and Controls:

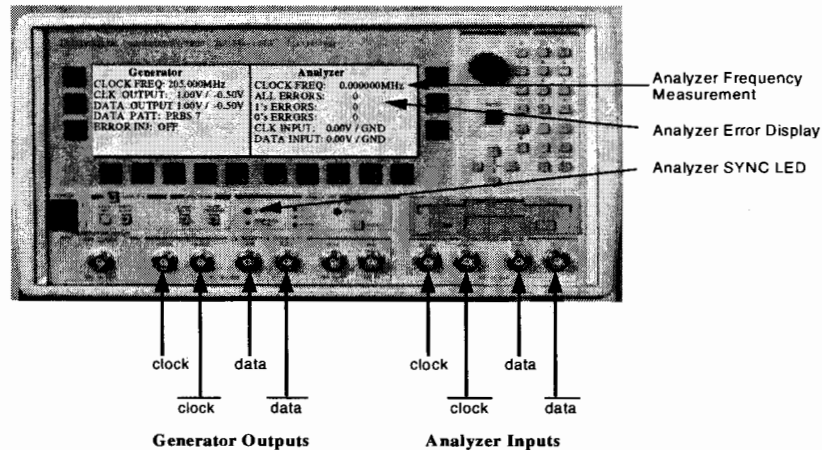

Background on MPEG packets

MPEG standards define methods to compress and encode higher speed video signals into lower speed packets. MPEG 1 focused on lower bandwidth (and thus lower quality) video at roughly 1.5 Mbps.

MPEG 2 uses many of the same techniques but focuses on 4-15 Mbps for “main profile, main level” and higher bit rates for the “high profile” compliance points. MPEG Systems are designed to work over a minimal transmission medium . It overlaps somewhat with the transport layers of both IP and ATM. The ATM community, for example, had assumed that video and audio would be sent on separate ATM Virtual Circuits (VC).

MPEG packets are small in size (188 bytes). They were designed to facilitate error concealment (to do this packets should be small) and to be compatible with ATM (188 = 4 * 47, where 47 was thought at the time to be the size of a ATM cell payload). Multiple packets are grouped together to form MPEG streams. There are actually two types of MPEG System Streams: *Program Streams* and *Transport Streams*.

Program Streams (PS or MPS) are backward compatible with MPEG 1 System Streams. They are best used in relatively error free environments such as CD-ROM storage. Only one program is allowed per program stream. *Transport Streams* (TS or MTS) are fine-grain packetized streams for use in more error-prone environments. Transport streams support all the functionality of program streams but also allows multiple programs to be muxed into a single stream.

A diagram of the transport packet syntax is shown below, and the byte structure follows the first figure on this page.

Transport Packet Syntax - Adaptation Fields

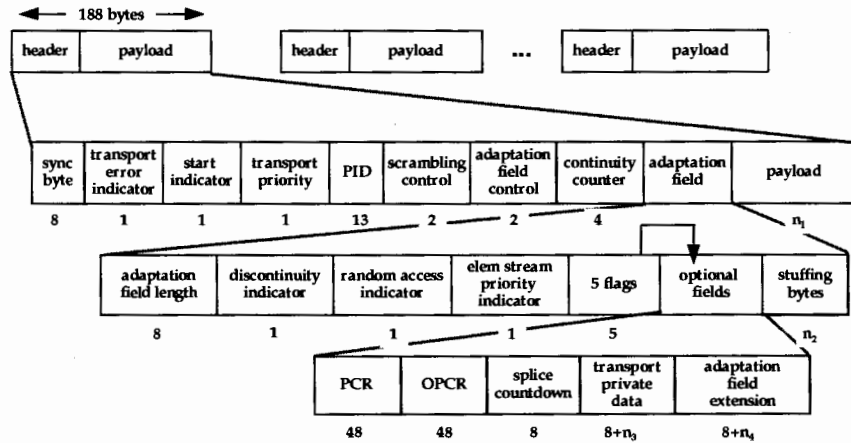

MPEG-2 transport streams

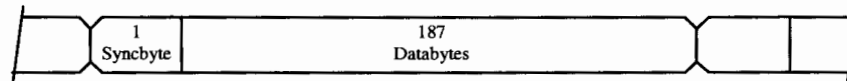

MPEG-2 Transport Stream

Review of Mixed Mode Patterns

The PB200 derives its “mixed mode” and “packet” operation from three internal Random Access Memories which are user programmable. We can choose to make Memory 1 the “payload” and apply a PRBS for error analysis. And we can write a custom word, or a series of custom words in Memory 2 to represent the “overhead”. The third memory, or “mux” memory controls the selection of bits from either Mem 1 or Mem 2 to form the desired output sequence.

A simplified view of the PB200 pattern memories is shown in the figure below.

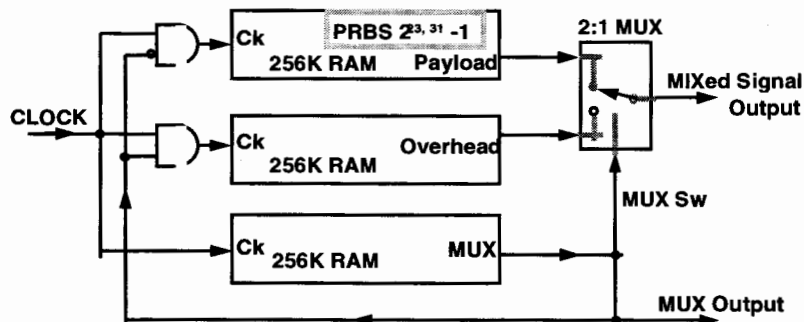

Generator and Analyzer circuits are identical but independent

PB200 Pattern Generator (simplified view)

Creating MPEG 2 packets for the PB200

A basic transport packet for MPEG 2 is 188 bytes in length. The first byte (8-bits) is the sync byte containing hex 47. For the simplest of MPEG packets, the remaining 187 bytes can be considered payload and can be filled with PRBS data. In this example, we would require 1 byte of overhead and 187 bytes of payload. Because the minimum size for overhead memory in the PB200 is 2 bytes, we would fill the overhead memory with two bytes of hex 47.

The structure of an MPEG-2 packet for PB200 pattern memory is shown in the figure below.

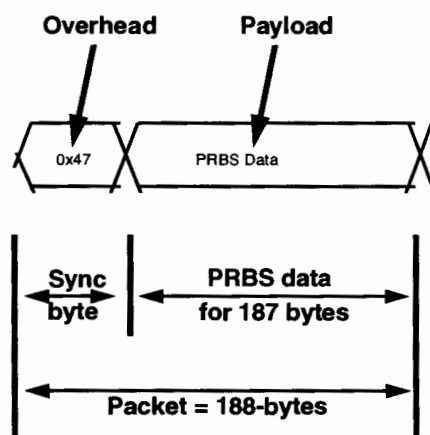

Simplified MPEG2 packet for pB200

PB200 Pattern Memory Programming

To create the simplified MPEG-2 packet shown in the previous figure, the PB200 memories can be programmed directly from the front panel or individual pattern memory files can be loaded.

Sample pattern files for the mux, overhead, and payload memories are shown below.

MUX Pattern Memory File - "mpeg2_v2.gmx"

```
--- packetBERT / gigaBERT Pattern
--- Microwave Logic Inc.
--- Numeric Format: HEX
--- Bit Order: MSB
1504      <- this is the memory size in bits (188 bytes x 8 bits per byte)
FF 00 00 00 00 00 00 00 00 00 00 00 00 00 00 00
00 00 00 00 00 00 00 00 00 00 00 00 00 00 00 00
00 00 00 00 00 00 00 00 00 00 00 00 00 00 00 00
00 00 00 00 00 00 00 00 00 00 00 00 00 00 00 00
00 00 00 00 00 00 00 00 00 00 00 00 00 00 00 00
00 00 00 00 00 00 00 00 00 00 00 00 00 00 00 00
00 00 00 00 00 00 00 00 00 00 00 00 00 00 00 00
00 00 00 00 00 00 00 00 00 00 00 00 00 00 00 00
00 00 00 00 00 00 00 00 00 00 00 00 00 00 00 00
00 00 00 00 00 00 00 00 00 00 00 00 00 00 00 00
00 00 00 00 00 00 00 00 00 00 00 00 00 00 00 00
00 00 00 00 00 00 00 00 00 00 00 00 00 00 00 00
00 00 00 00 00 00 00 00 00 00 00 00 00 00 00 00
00 00 00 00 00 00 00 00 00 00 00 00 00 00 00 00
00 00 00 00 00 00 00 00 00 00 00 00 00 00 00 00
00 00 00 00 00 00 00 00 00 00 00 00 00 00 00 00
00 00 00 00 00 00 00 00 00 00 00 00 00 00 00 00
00 00 00 00 00 00 00 00 00 00 00 00 00 00 00 00
00 00 00 00 00 00 00 00 00 00 00 00 00 00 00 00
```

Overhead Pattern Memory File - "mpeg2_v2.goh"

```
--- packetBERT / gigaBERT Pattern
--- Microwave Logic Inc.
--- Numeric Format: HEX
--- Bit Order: MSB
16
47 47
```

Payload Pattern Memory File - "mpeg2_v2.gpl"

Note: contents and length of this memory do not matter as the actual payload data will be driven from the PRBS generators.

```
--- packetBERT / gigaBERT Pattern
--- Microwave Logic Inc.
--- Numeric Format: HEX
--- Bit Order: MSB
16
00 00
```

1. Connect the Generator to the Analyzer as shown below:

GENERATOR		ANALYZER	
generator clock output	⇒	analyzer clock input	
generator n_clock output	⇒	50Ω terminator	
generator data output	⇒	analyzer data input	
generator n_data output	⇒	50Ω terminator	

2. Power up and reset unit.

Power up the unit and perform a factory default reset (Press the key “UTILITY” and the soft key “FACTORY DEFAULT”).

3. Setup Generator for Mixed Mode.

On the GENERATOR window, press the soft key “DATA PATTERN”. Setup the mode for MIXED operation and the mixed mode contents (payload) for PRBS-15. The DATA PATTERN menu should look like the following:

GENERATOR		
DATA PATTERN		
MODE	MIXED	
PRBS	PRBS 7	⇐ this value is not for mixed mode (see below menu)
MARK DENSITY	MARK RATIO 1/2	
PRE-AMBLE	OFF	
START MODE	STOP	
LOAD PATTERN ...		
STORE PATTERN ...		
RECALL PATTERN ...		
MIXED MODE CONTENTS ...		⇐ identifies mixed mode payload contents

Position the cursor in the GENERATOR window and scroll to the MIXED MODE CONTENTS option. Press the “ENTER” key and a pop-up menu will appear. Setup the popup menu as follows:

GENERATOR		
DATA PATTERN		
PAYLOAD		
MODE	PRBS	
PRBS	PRBS 15	⇐ identifies payload data type for MIXED MODE
MARK DENSITY	MARK RATIO 1/2	
NOTE: MIXED MODE CONTENTS only affect MIXED MODE data patterns.		

*Notes: Hit the enter key to see the available options for each selection.
Hit the data pattern softkey to enter or exit the data pattern menu.*

4. Setup Analyzer for Mixed Mode.

On the ANALYZER window, press the soft key "DATA PATTERN". Setup the mode for MIXED operation and the mixed mode contents (payload) for PRBS-15. The DATA PATTERN menu should look like the following:

ANALYZER		
DATA PATTERN		
MODE	MIXED	
PRBS	PRBS 7	← this value is ignored in mixed mode
MARK DENSITY	MARK RATIO 1/2	
PRE-AMBLE	OFF	
LOAD PATTERN ...		
STORE PATTERN ...		
RECALL PATTERN ...		
MIXED MODE CONTENTS ...		← identifies mixed mode payload contents
STORE/RECALL SETUP ...		

Position the cursor in the ANALYZER window and scroll to the MIXED MODE CONTENTS option. Press the "ENTER" key and a pop-up menu will appear. Setup the popup menu as follows:

ANALYZER		
DATA PATTERN		
PAYLOAD		
MODE	PRBS	
PRBS	PRBS 15	← identifies payload data type for MIXED MODE
MARK DENSITY	MARK RATIO 1/2	
NOTE:	MIXED MODE CONTENTS only affect MIXED MODE data patterns.	

Note: Hit the DATA PATTERN softkey to exit.

5. Load the MPEG2 patterns from floppy disk

Insert the "sample MPEG2 patterns" diskette into the disk drive located above the analyzer inputs.

On the GENERATOR window, press the soft key "DATA PATTERN". Scroll to the RECALL PATTERN option. Press the "ENTER" key and the following popup menu will appear:

RECALL PATTERN		
FILE TYPE:	OVERHEAD	<- type of pattern file or ALL
FILE NAME:	..No..Files	<- user defined filename

Position the cursor on the **FILE TYPE** entry and press **ENTER**. The following pop-up menu will be displayed:

FILE TYPE	
OVERHEAD	
PAYLOAD	
MUX	
PRE	
GAP	(Generator only)
ALL	

<- select ALL to store ALL patterns

Scroll down the file type list using the **arrow keys** and press **ENTER** at the **ALL** file type. The following pop-up menu will be displayed *after the disk is read*:

RECALL PATTERN	
FILE TYPE:	ALL
FILE NAME:	SAMPLE1

<- type of pattern file or ALL
<- user defined filename

Position the cursor on the **FILE NAME** entry and press **ENTER**. The following pop-up menu will be displayed:

FILE NAME	
MPEG2_V2	
<i>filename2</i>	
<i>filename3</i>	
<i>filename4</i>	

<- names of all files on floppy

After loading, the final pop-up menu will be displayed as follows:

RECALL PATTERN	
FILE TYPE:	ALL
FILE NAME:	MPEG2
PATTERN LOAD STATUS:	
PAYLOAD	COMPLETE
OVERHEAD	COMPLETE
MUX	COMPLETE
PRE-AMBLE	COMPLETE
CLOCK GAP	COMPLETE

<- type of pattern file or ALL
<- user defined filename
<- loads MPEG2_V2.GPL
<- loads MPEG2_V2.GOH
<- loads MPEG2_V2.GMX
<- loads MPEG2_V2.GPR
<- loads MPEG2_V2.GGP

You should see the a Load Status of “**COMPLETE**” on all loaded files. If your file is named or formatted incorrectly, you will receive a **NOT READ** status.

6. Copying Generator patterns to Analyzer Memory

On the ANALYZER window, press the soft key "PATTERN COPY". The following pop-up menu will be displayed:

PATTERN COPY	
COPY PATTERN	
FROM GENERATOR	
TO ANALYZER: ALL 4	

Press the ENTER key, position the cursor on the ALL 4 copy pattern type, and press ENTER. All generator pattern files have now been copied to the analyzer.

Note: Hit the ESC key to exit.

7. Start the Generator

Press the pattern key "START/STOP". The LED inside the START/STOP key will light. Press the error history key "CLEAR". All of the Analyzer Error History LED's should clear (turn off). The Analyzer display should look as follows:

ANALYZER				SLIP CTRL
CLOCK FREQ:	205.000 MHz			ENAB
ALL ERRORS:	0 / 0.00E-08			AUTO
1'S ERRORS:	0 / 0.00E-08			SEARCH
0'S ERRORS:	0 / 0.00E-08			OFF
CLK INPUT:	0.00V / GND			EYE
DATA INPUT:	0.00V / GND / 0.000nS			WIDTH
DATA PATT:	MIXED			OFF
CLOCK INPUT	DATA INPUT	DATA PATTERN	AUTO SEARCH	MORE... 1 OF 3

8. Check for Error Free Operation

Check for error free operation of the unit. You should notice the SYNC active (LED ON), no Errors, and Analyzer frequency measurement accurate to within 1%.

Note: Depending upon your cable length, you may need to delay your clock to obtain immediate synchronization upon pressing the "START/STOP" button. As needed, change the Analyzer to add a Startup Delay of one (1) clock. This setting is in the "DATA INPUT" ANALYZER menu.

STOP and then START unit. Again check for error free operation of the unit.

Disconnect the **DATA** cable at the Analyzer input. Notice what happens. Re-connect the **DATA** cable to the Analyzer **DATA** input and press the error history key "**CLEAR**". Unit should now be error free.

Note: If you find that you are now seeing "bit errors" yet still have synchronization, think about this. Depending upon your test pattern, you may need to adjust your error sync threshold to a higher value. The default setting is 1 or a 25% error rate. In the **ANALYZER** window, enter the "**ERROR MODE**" menu and adjust the **SYNC THRESHOLD** to different values (try a value of 8).

Disconnect the **CLOCK** cable at the Analyzer input. Notice what happens. The unit's factory reset condition utilizes an internal clock connection between Generator and Analyzer. No clock cable is required for this mode of operation. Re-connect the **CLOCK** cable to the Analyzer **CLOCK** input.

9. Change Analyzer to External Clock

On the **ANALYZER** window, press the soft key "**CLOCK INPUT**". Scroll down to the **CLOCK SOURCE** selection and press the "**ENTER**" key. Press the down arrow key so that **EXT** is in reverse video. Press the key "**ENTER**" to perform the action. This will select the external (i.e. front panel) clock as the input to the Analyzer.

On the **ANALYZER** window, press the soft key "**CLOCK INPUT**" to remove the menu.

Check for error free operation of the unit. You should notice the **SYNC** active, no **Errors**, and Analyzer frequency measurement accurate to within 1%. The **INTERNAL CLOCK LED** should now be turned off.

STOP and then **START** unit. Again check for error free operation of the unit.

Disconnect the **CLOCK** cable at the Analyzer input. Notice what happens. Re-connect the **CLOCK** cable to the Analyzer **CLOCK** input and press the error history key "**CLEAR**". Unit should now be error free.

***Note:** This may take a while depending on the value of your sync error threshold setup in step 8.*

10. Inject an Error

On the **GENERATOR** window, press the soft key "**SINGLE ERROR**" one time. This will inject one error into the Generator Data output. You should notice the following:

- Analyzer display "Errors" will count 1
- Error Rate will change to something other than 0
- The Error History "**BIT**" LED will illuminate.
- Either the 1's or the 0's error display will also have counted the injected error - this depends on whether the error was injected on an outgoing one or zero in the pattern

Now press the soft key "**SINGLE ERROR**" several time and watch the error counts increase.

Press the error history key "**CLEAR**" and confirm error free operation of the unit.

Appendices

Appendices

Specifications - PB200	2
System Performance Verification	5
Loading and Storing Pattern Files with the PB200	9
PRBS Patterns with the PB200	15
Diskette File Format	16
Pattern Editor Requirements and Features	19
Default Factory Settings	29
Reports	34
Cleaning Instructions	37
Glossary	38
Index	41

Specifications - PB200

Generator	
<i>Clock</i>	
External Clock Input	
Frequency	dc to 200 MHz
Amplitude	0.5-5.0V p-p, BNC
Termination Select	50 Ohm to -2V, +3 V, AC or GND
Input Range	ECL, TTL, PECL compatible
Threshold Resolution	10 mV step
External Clock Reference Input	
Frequency	10 MHz, ± 100 ppm max
Amplitude	0.5-2.0 V p-p, AC coupled 50 Ohm
Termination	AC coupled 50 Ohm, BNC
Internal Synthesized Clock Source	
Frequency	1 Hz - 200 MHz
Resolution/Accuracy	1 Hz/ 10 ppm
Burst Clock	
Programmable Gap	128 Kbit max., 8-bit resolution
Pattern Generator	
PRBS	2^n-1 , N=31, 23, 15, 11, 9, 7
Programmable Word	256 Kbit max, 8-bit resolution
Mark Density	PRBS $2^{10}-1$ (1/8, 1/4, 1/2, 3/4, 7/8)
Mixed Mode Frame	256 Kbit max, 8-bit resolution
Preamble	0-16 Kbit

Error Injection	
Error	Single, Rate, External (TTL)
Field Select	Overhead, Payload or Both
Error Rates	Error Rate of 10^{-n} , n=3, 4, 5, 6, 7
Outputs	
Data and Clock Outputs	
Format	NRZ
Configurations	Differential (True/Complement)
Source Impedance	50 Ohm, BNC
Amplitude	0.5 V to 2.0 V, 10 mV step
Offset, 50 Ohm to GND	-2.0 V to +1.8 V, 10 mV step (Termination to +3 V will increase the range for PECL)
Data Delay Range	± 1.0 nS, 20 pS resolution
Rise/Fall time	300 pS typical, 500 pS max., (20-80%)
Pattern Sync. Output	
Signal Level	250 mVp-p into 50 Ohm load
Auxiliary	
Data Inhibit Input	ECL, 50 ohm to -2 V, BNC
Clock Disable Input	ECL, 50 ohm to -2 V, BNC

Analyzer	
Data and Clock	
Clock Input	
External or Internal from Generator	
Data and Clock Input	
Data Polarity	True/Invert Selectable
Input Mode Select	Single-Ended or Differential
Termination Select	50 Ohm to -2 Vm +3 Vm AC or GND
Input Threshold	Variable, depends on input termination 50 Ohm to GND: -2 to +4 V 50 Ohm to -2 V: -3 to +3 V 50 Ohm to +3: -1.5 to +4.5 V AC: -2 to +2 V
Threshold Resolution	10 mV step
Synchronization	
Auto Search	Clock & Data Threshold Clock & Data Timing Skew Data Pattern & Polarity
Measurements	
Frequency	1 Hz to 200 Hz
Bit Errors	Window, Totalize, Timed Test, Simultaneous 1s, 0s, and All-Errors
BER Test field	Overhead, Payload or Both
Propagation Delay	Up to 128 Kbit
Eye Width	Up to 32 nS

Reference Data Patterns	
Identical to Pattern Generator, but independent	
Startup Delay	0-64 Kbits programmable
Auxiliary	
Error Count Inhibit Input	ECL, 50 Ohm to -2 V, BNC
Error Detect Output	RZ, TTL, 50 Ohm source, BNC
Analyzer Clock Disable	ECL, 50 Ohm to -2 V, BNC
Data Delay Output	ECL, 50 Ohm source, BNC

Common	
Pattern	
Controls	Start/Stop, Pause/Resume or Single Step
Save/Load	
Floppy Disk	3.5"
Internal Storage	2 Mbits
Remote Interface	
GPIB	IEEE 488.2 compatible
RS-232C	DB9 connector
Parallel Printer	DB25 connector
Monitor	VGA analog output, DB15

Environmental Specification	
Power	AC power inputs accepts either nominal 115 VAC or 230 VAC, 300 W max.
Temperature	Operation +5 to +40 degrees C Storage -10 to +60 degrees C
Size	8" H x 14"W x 20"D 20.3 cm H x 35.6 cm W x 50.8 cm D
Weight	30 lbs. (13.7 kilograms)

Safety Certification Compliance	
Category	Standard
Temperature (operating)	+5 to +40°C
Altitude (maximum operating)	2000 meters
Equipment Type	Test and Measuring
Safety Class	Class I (as defined in IEC 1010-1, Annex H) - grounded product
Overvoltage Category	Supply Input - Overvoltage Category II (as defined in IEC 1010-1, Annex J) Measuring Inputs - Overvoltage Category I (as defined in IEC1010-1, Annex J)
Pollution Degree	Pollution Degree 2 (as defined in IEC 1010-1). Note - Rated for indoor use only.

Low Voltage Declaration	
Category	Standard
EC Declaration of Conformity - Low Voltage	<p>Compliance was demonstrated to the following specification as listed in the Official Journal of the European Communities:</p> <p>Low Voltage Directive 73/23/EEC</p> <p>EN61010-1/A1 - Safety Requirements for Electrical Equipment for Measurement, Control, and Laboratory Use.</p> <p>Particular requirements for hand-held probe assemblies for electrical measurement and test equipment.</p> <p>Particular requirements for hand-held current clamps for electrical measurements and test.</p>
<p>Installation Category Descriptions</p> <p>Terminals on this product may have different installation category designations. The installation categories are:</p> <p>CAT III Distribution-level mains (usually permanently connected). Equipment at this level is typically in a fixed industrial location</p> <p>CAT II Local-level mains (wall sockets). Equipment at this level includes appliances, portable tools, and similar products. Equipment is usually cord-connected.</p> <p>CAT I Secondary (signal level) or battery operated circuits of electronic equipment.</p>	

System Performance Verification

The following procedure is used to verify basic system performance.

Item	Qty	Description
1	4	24 ±6" 50 ohm BNC coax cable
2	1	300 MHz bandwidth oscilloscope *
3	1	Frequency counter **

* Example -Tektronix 2465

** Example -Hewlett Packard 5386A

If this is the first time you have operated a PB200, refer to SECTION 1 "Getting Started" for operating instruction.

1. Switch the power to the unit ON.
2. Place the PB200 supplied 50 ohm terminators on the Generator Inverted Clock/Data Outputs.

Generator Output Levels

1. Set the Internal Clock frequency to 100MHz.
2. Set the Generator to PRBS7.
3. Set the Generator Data and Clock outputs to:
AMPLITUDE = .50V
OFFSET = -2.00V
4. Press the START/STOP key to START the unit. (LED on)
5. Connect the PB200 SYNC output to the Oscilloscope sync input with 50 ohm coax.
6. Connect the Data output to channel 1, and the Clock output to channel 2 of the oscilloscope with 50 ohm coax.
7. Switch the scope channel inputs to 50 ohms. (If scope does not provide this, use a 50 ohm terminator).
8. Verify that the Data and Clock $VOH = -1.50V \pm 100mv$
9. Output levels are correct. $VOL = -2.00V \pm 100mv$
Change the Data and Clock to: $AMP = 2.00V$
 $OFF = -2.00V$

- | | |
|---|--|
| 10. Verify that the Data and Clock Output levels are correct. | VOH = 0.00V+/-100mv
VOL = -2.00V+/-100mv |
| 11. Change the Data and Clock to: | AMP = 2.00V
OFF = +.80V |
| 12. Verify that the Data and Clock Output levels are correct. | VOH = 2.80V+/-100mv
VOL = .80V+/-100mv |
| 13. Change the Data and Clock to: | AMP = 2.00V
OFF = -1.00V |
| 14. Verify that the Data and Clock Output levels are correct. | VOH = +1.00V+/-100mv
VOL = -1.00V+/-100mv |

Generator Clock Frequency

1. Connect the PB200 Clock output to the Frequency counter.
2. Verify that the measured frequency is within the limits listed.

Frequency (Hz)	Low Limit	High Limit
10	9.9999	10.0001
100	99.9990	100.0010
1,000	999.9900	1,000.0100
10,000	9,999.9900	10,000.1000
1,000,000	999,990.0000	1,000,010.0000
10,000,000	9,999,900.0000	10,000,100.0000
100,000,000	99,999,000.0000	100,001,000.0000
200.000000	199,998,000.0000	200,002,000.0000

Analyzer Frequency Measurement/Internal Clock

1. Select the Analyzer Internal Clock.
2. Verify that the Analyzer measures the Generator frequency to within +/- 100ppm at 1MHZ, 10MHZ, 100MHZ, 200MHZ.

Pattern Test

Connect the Generator Clock and Data outputs to the respective Analyzer Clock and Data inputs with two 24" BNC coax cables. 50 ohm terminators should be on the Clock bar and Data bar outputs.

Setup The Unit As Follows:

Generator		Analyzer	
Data Amp	2.00 v	Clock	Single-ended
Data Off	-1.00 v	Clock Thres	0.00 v
Data Delay	0.00 ns	Clock Term	Gnd
Data Polarity	Normal	Clock Srce	External
Clock Amp	2.00 v	Data	Single-ended
Clock Off	-1.00 v	Data Thres	0.00 v
Clock Freq	200 MHz	Data Term	Gnd
Pattern	PRBS7	Input Delay	0.00 ns
		Data Polarity	Normal
		Pattern	PRBS7

1. After setting up the unit as above, press the CLEAR key in the HISTORY box.
2. Verify all history LEDS go OFF.
3. Press the START/STOP key to start the unit.
4. Verify the Analyzer begins measuring the frequency.
5. Verify that the Analyzer is error-free.
6. Press the PAUSE/RESUME key to pause the unit.
7. Verify that the unit pauses without errors.
8. Press the PAUSE/RESUME key to resume.
9. Verify that the unit resumes without errors.
10. Select each of the PRBS codes (9,10,11,15,23,31) on both the Generator and Analyzer to verify that they operate error free.

NOTE: After selecting each pattern you must press START/STOP to start the unit. Clear all errors before starting.

11. Load the sample pattern "SAMPLE PATTERN - PRBS 15 MIXED" from the 3.5" Diskette provided with the unit into the Generator and Analyzer.
12. Select MIXED pattern for the Generator and Analyzer.
13. Press the START/STOP to start the unit.

14. Verify that the MIXED pattern operates error free.
15. Set the Generator and Analyzer Data polarity to INVERT.
16. Clear the errors, and start the unit.
17. Verify that INVERT operates error free.
18. Leave this setup for the next test.

Differential Test

1. Press START/STOP to stop the unit.
2. Remove the 50 ohm terminators from the Generator Clock bar and Data bar outputs.
3. Connect the Generator Clock bar and Data bar outputs to the Analyzer respective inputs with 24" 50 BNC coax cables. They must be the same length as the Clock and Data coax cables which are already connected.
4. Select Differential for the Clock and Data inputs of the Analyzer.
5. Press the START/STOP key to start the unit.
6. Verify the unit runs error-free.

Error Inject Rate Test

1. Select each of the Generator error inject rates.

Note: After you select an error inject rate, clear the history by pressing the CLEAR key in the HISTORY box.

This will clear the previous bit and error counters so that the Analyzer rate calculation is started with the injected error rate already applied. Otherwise it will take time to collect enough bits to make the period before the error rate changed insignificant in the Analyzer error rate calculation.

2. Verify that the Analyzer measures each error rate.
1e-3, 1e-4, 1e-5, 1e-6, 1e-7.
3. Turn error inject OFF.

This ends the test for System Performance Verification.

Loading and Storing Pattern Files with the PB200

File Naming Conventions

The PB200 has two methods for naming disk files - default and enhanced.

Each method permits users to store and retrieve Generator and Analyzer pattern files from a floppy disk. File naming conventions for these methods are listed in the table below.

File Type	Default Filenames	Enhanced Filenames
Generator Payload	gen_pyld.pat	<i>username.gpl</i>
Generator Overhead	gen_oh.pat	<i>username.goh</i>
Generator Mux	gen_mux.pat	<i>username.gmx</i>
Generator Preamble	gen_pre.pat	<i>username.gpr</i>
Generator Clock Gap	gen_gap.pat	<i>username.ggp</i>
Analyzer Payload	an_pyld.pat	<i>username.apl</i>
Analyzer Overhead	an_oh.pat	<i>username.aoh</i>
Analyzer Mux	an_mux.pat	<i>username.amx</i>
Analyzer Preamble	an_pre.pat	<i>username.apr</i>

All filenames follow the MS-DOS format. The format is "filename.extension". Each filename is limited to 8-characters and must start with an alpha (a-z) character. Each file extension is limited to 3 characters.

The default method will only load correctly formatted patterns with the unique filename and the .pat file extensions. This means that only one set of files can be stored on a floppy disk. To load pattern files using the default method, select the menu option "Load Pattern".

The enhanced method will load any corrected formatted patterns named username with the correct file extension. This means that multiple sets of test patterns can be stored on a floppy disk. To load pattern files using the enhanced method, select the menu option "Recall Pattern".

Menu Options

Three menu options are used for loading and storing pattern files. The generator and analyzer options are shown below.

Generator Data Pattern Menu Options

Data Pattern	
Mode	Mixed
PRBS	PRBS7
Mark Density	Mark Ration 1/2
Pre-amble	Off
Start Mode	Stop
Load Pattern ...	<i><-- Load patterns using default file names</i>
Store Pattern ...	<i><-- Store patterns using enhanced file names</i>
Recall Pattern ...	<i><--Load patterns using enhanced file names</i>
Mixed Mode Contents ...	

Analyzer Data Pattern Menu Options

Data Pattern	
Mode	Mixed
PRBS	PRBS7
Mark Density	Mark Ration 1/2
Pre-amble	Off
Start Mode	Stop
Load Pattern ...	<i><-- Load patterns using default file names</i>
Store Pattern ...	<i><-- Store patterns using enhanced file names</i>
Recall Pattern ...	<i><--Load patterns using enhanced file names</i>
Mixed Mode Contents ...	
Store/Recall Setup ...	<i><-- Store analyzer setup in binary file</i>

Storing Data Patterns

To store test patterns, select the Store Pattern option from either the Generator or Analyzer menu and press Enter. The following pop-up menu will be displayed.

Store Pattern	
File name: MPEG2	<-- User defined filename
File Type: Overhead	<-- Type of pattern file or ALL

To enter your filename, position the cursor on the first character in the File Name field. Use the arrow keys to move the cursor and rotary entry knob to select the desired characters. When the file name is correct, move the cursor to the File Type line and press Enter. The following pop-up menu will be displayed.

File Type	
Overhead	
Payload	
MUX	
PRE	
GAP (Generator only)	
ALL	<-- Select all to store all patterns

Position the cursor on the appropriate file type (position cursor on ALL to store all pattern types). Press Enter to store the files on the floppy disk.

Loading Data Patterns (Default file names)

The Load Pattern option looks for disk files with the default naming convention (for example, gen_pyld.pat, gen_oh.pat, an_oh.pat, etc.). Select the Load Pattern option from either the generator or analyzer menu and press Enter. The following pop-up menu will be displayed.

```

Load Pattern
Load Pattern   From Disk
    
```

The words From Disk will be displayed in a reverse video. Press Enter and another pop-up menu will be displayed.

```

Load Pattern
From Disk
    
```

<-- Looks only for files with .PAT extension and correct prefix

Press Enter again and the floppy disk will be search for any files that match the default file naming convention. If correct files are located, they will be loaded and the following pop-up menu will be displayed.

```

Load Pattern
Load Pattern   From Disk

Pattern Load Status:
Payload        Complete
Overhead       Complete
MUX            Complete
Pre-amble     Complete
Clock gap      Complete
    
```

<-- loads gen_pyld.pat or an_pyld.pat
<--loads gen_oh.pat or an_oh.pat
<-- loads gen_mux.pat or an_mux.pat
<-- loads gen_pre.pat or an_pre.pat
<-- loads gen_gap.pat

Look for a Load status of COMPLETE on all loaded files. If a file is incorrectly named or formatted, a status of NOT READ will appear.

Recalling Data Patterns (Enhanced file names)

The Recall Pattern option looks for disk files with the enhancing naming convention (for example, username.gpl, username.apl, username.gmx, etc.). Select the Recall Pattern option from either the generator or analyzer menu and press Enter. The following pop-up menu will be displayed.

Recall Pattern		
File Type	Overhead	<-- type of pattern file or ALL
File Name	No Files	<-- user-defined file name

Position the cursor on the File Type entry and press Enter. Another pop-up menu will be displayed.

File Type		
Overhead		
Payload		
MUX		
Pre		
Gap	(Generator only)	
ALL		<-- select ALL to store ALL patterns

Scroll down the file type list using the Arrow keys and press Enter at the correct file type. The floppy disk will be searched to find files of the selected type. If you select ALL and press Enter (for all files), the following pop-up menu will be displayed.

Recall Pattern		
File Type	ALL	<-- type of pattern file or ALL
File Name	Sample1	<-- user-defined file name

Position the cursor on the File Name entry and press Enter. The following pop-up menu will be displayed.

File Name	
Sample1	<-- names of all files on floppy
MPEG2	
MPEG2_V2	
SONETV12	
ATM25MEG	

The list of file names can be larger than the screen (indicated by a double line on the right of the pop-up menu). Scroll down the desired file name using the arrow keys and press Enter. The files will now be loaded. After loading, the final pop-up menu will be displayed as follows.

Recall Pattern		
File Type	ALL	<-- type of pattern file or ALL
File Name	MPEG2	<-- user-defined filename
Pattern Load Status:		<-- loads mpeg.gpl or meg2.apl
Payload	Complete	<-- loads mpeg.goh or meg2.aoh
Overhead	Complete	<-- loads mpeg.gmx or meg2.amx
MUX	Complete	<-- loads mpeg.grp or meg2.apr
Pre-amble	Complete	<-- loads mpeg.gcp
Clock gap	Complete	

Look for a Load status of COMPLETE on all loaded files. If a file is incorrectly named or formatted, a status of NOT READ will appear.

PRBS Patterns with the PB200

ITU Specifications (O.150 and O.151) identify several types of PRBS patterns used for communications testing. These patterns are usually generated by hardware shift registers with appropriate feedback. If the shift has n -stages, the maximum pattern length will be $2^n - 1$.

If the digital signal is taken directly from the output of the shift register (non-inverted signal), the longest string of consecutive ZEROs will equal $n - 1$. If the signal is inverted, n consecutive ZEROs will be produced.

The table below taken from ITU Specification O.150 lists several different types of PRBS test patterns. Some of the recommended test patterns use "non-inverted" signals (PRBS 9, 11, 23), some use "inverted" signals (PRBS 15), and some use both the "non-inverted" and the "inverted" signals (PRBS 20).

The PB200 is capable of inverting data on both TX and RX. This provides full flexibility to adjust the PRBS signal to the user's exact requirements. The table below identifies the polynomial and shift register feedback taps used to generate PRBS data.

PRBS Polynomials and Shift Register Feedback Taps

N	Menu Label	PRBS Pattern	Primitive Polynomial	Feedback Taps	Length ($2^n - 1$ bits)
7	PN 7	$2^7 - 1$	$x^7 + x + 1$	6 and 7	127
9	PN 9	$2^9 - 1$	$x^9 + x^4 + 1$	5 and 9	511
10	PN 10	$2^{10} - 1$	$x^{10} + x^3 + 1$	7 and 10	1,023
11	PN 11	$2^{11} - 1$	$x^{11} + x^2 + 1$	9 and 11	2,047
15	PN 15	$2^{15} - 1$	$x^{15} + x + 1$	14 and 15	32,767
23	PN 23	$2^{23} - 1$	$x^{23} + x^5 + 1$	18 and 23	8,388,607
31	PN 31	$2^{31} - 1$	$x^{31} + x^3 + 1$	28 and 31	2,147,483,647

Diskette File Format

This appendix describes the format for files that are downloaded via the PB200 diskette drive to the PB200 hardware.

Comments can be put at the top of the file only to describe the file, or to select a decimal format. Each line must start with three dashes.

To select decimal input format the keyword 'DEC' must be in the comment field in uppercase letters.

NOTE: Any occurrence of the keyword DEC in the comment field will select the decimal format.

EXAMPLE:

```
--- PB200 Pattern Disk
--- Microwave Logic Inc.
--- Pattern: Trigger pattern
--- DEC
```

ASCII File Format

Each ASCII pattern file should have a ".PAT" file extension. There are six permitted pattern files: GEN_OH.PAT, GEN_MUX.PAT, HEX, GEN_PYLD.PAT, AN_OH.PAT, AN_MUX.PAT, AN_PYLD.PAT

An example of the data format for an ASCII pattern file is shown below in the following short example (<cr> is a carriage return typed by the user and <eof> is an End-Of-File):

```
272<cr>
10 11 12 13 14 15 16 17 18 19 1a 1b 1c 1d 1e 1f<cr>
20 21 22 23 24 25 26 27 28 29 2A 2B 2C 2D 2E 2F<cr>
20 21 <eof>
```

An example of the decimal format for an ASCII pattern file is shown below.

```
400 <cr>
255 0 255 0 0 0 1 2 3 4 5 6 7 8 9 10 <cr>
64 64 64 64 64 64 64 64 64 64 64 64 64 64 64 <cr>
128 128 128 128 128 128 128 128 192 192 192 192 192 192 192
<cr>
```

```
255 255 <eof>
```

The bit length of the pattern must be on the first line of the file. The pattern length **MUST** be a multiple of eight bits.

The pattern starts immediately on the second line. If the length of the pattern is greater than 128 bits (16 bytes), then each line in the ASCII pattern file, with the exception of the last line, must contain the ASCII representation of sixteen bytes. Either upper or lower case letters can be used.

A sixteen byte pattern line can be no longer than 80 characters. **ONLY** blanks (SPACE characters) can be used to separate bytes on a line.

The ASCII pattern file **MUST** end on its last line as shown by the <eof> symbol in the above example.

Note that the following format is not currently permitted even though it might seem to be the "natural" way to format the ASCII pattern file.

```
272<cr>
10 11 12 13 14 15 16 17 18 19 1a 1b 1c 1d 1e 1f<cr>
20 21 22 23 24 25 26 27 28 29 2A 2B 2C 2D 2E 2F<cr>
20 21 <cr>
<eof>
```

Common Formatting Errors

If the bit length given on the first line is not a multiple of eight bits, the ASCII pattern file will not be converted to the needed internal format.

With the exception of the last pattern line, if more than 16 bytes appear on a line, the pattern conversion will fail.

Separating bytes with "white space" characters other than blanks is not permitted.

Ending the last pattern line with a <cr> instead of an <eof> will result in a failed conversion.

Error messages

MISSING DISKETTE

Problem: There is no diskette in the drive when an attempt was made to read a pattern file.

Solution: Ensure a diskette has been inserted into the floppy drive.

INVALID FILENAME

Problem: The filename "typed" by the user cannot be used. either a blank filename was used or there is an embedded blank in the filename.

Solution: Specify a filename without embedded blank characters.

PATTERN READ ERROR

Problem: Unable to read a pattern from the diskette.

Solutions: Ensure a floppy diskette has been inserted.
Check for correctly formatted pattern files on the floppy.

PATTERN WRITE ERROR

Problem: Unable to write a pattern to the diskette.

Solutions: Ensure a floppy diskette has been inserted.
Check for available free space on the floppy.

FILE READ ERROR

Problem: Unable to write setup data to diskette.

Solutions: Ensure a floppy diskette has been inserted.
Check for available free space on the floppy (600 Bytes).

FILE WRITE ERROR

Problem: Unable to write setup data to diskette.

Solutions: Ensure a floppy diskette has been inserted.
Check for available free space on the floppy (600 Bytes).

Pattern Editor Requirements and Features

Version 1.10 (9/13/96)

Before You Begin:

Before installing this program, it is suggested that you make a copy of this disk and store it away in a safe place. To protect against accidentally overwriting any files on this disk, slide the write protect tab on the back of the disk to the protect position.

To Install MLPE:

- 1) Start Microsoft Windows.
- 2) In the FILE pulldown menu, choose RUN.
- 3) Type A:\SETUP or B:\SETUP.
- 4) Choose the OK button.
- 5) The program will install and create a new Program Manager group.
- 6) The README document is this document.
- 7) The installation is complete.

What is MLPE?

MLPE is a specialized pattern editor that can be used with Tektronix gigaBERT700/1400 series and packetBERT200 BERT products. It allows the user to create, store, edit, and transfer user defined and created patterns to and from the BERTS.

Patterns can be created in several different formats and easily converted from one format to another. The editor allows multiple files to be open at a time to make editing and transferring data between files easier. See the list of features described later in this document.

Minimum Requirements:

Microsoft Windows 3.1 or later running on a 386 or faster machine with 4 Mb of memory, For reasonable speed, a 486 DX or DX2 with at least 8 Mb of memory.

At least 2 Mb of free hard disk space.

gB700 Tx or Rx with 128K memory.

gB1400/1600 Tx or Rx with at least 256K memory.

A PB200.

One free RS-232 port or a National Instruments GPIB card with associated driver and software.

List of Features

- Editing capability in excess of 1 Mb. File size is in increments of 1 bit.
- Files can be displayed, edited, and saved in Hex, Decimal, Octal, or Binary formats.
- Data can be saved or displayed LSB (Least Significant Bit) or MSB (Most Significant Bit) first.
- Files saved in one format can be converted to any of the other three formats.
- Multiple editing windows can be open simultaneously to allow working on several files at once.
- The editor runs under Microsoft Windows with full Windows printing capability.
- Extensive built-in help.
- Data can be uploaded to a gB700/1400/1600 Tx or Rx via RS-232 or GPIB.
- Uploaded data can be saved in any memory location for any memory configuration, even while the instrument is performing tests.
- Data can be downloaded from a gB700/1400 Tx or Rx via RS-232 or GPIB. Downloaded data can be saved to disk for safe keeping or later editing, even while the instrument is performing tests.
- Data can be saved to disk and read from disk in a format compatible with the PB200, both current single file per disk and future multiple files per disk formats.
- The editor has full cut, paste, and copy facilities along with a last action delete UNDO.
- The editor has full find and replace functions.
- Replaced data can be a different length than the data it is replacing.

What the editor cannot do:

- The editor uses a proprietary editor and therefore cannot share data with other applications via the Clipboard.
- The editor will not work with the GB660.

List of Files on this Disk

SETUP.EXE

SETUP.INS

README.DOC

MLPE.Z

MLPE.INI

MLPE.BMP

FPGRID10.VBX

Please verify that the above files are on this disk. If any are missing, please contact Tektronix.

If you are using an alternate shell, such as Norton Desktop

In some cases the program will not install properly if an alternate shell, such as Norton Desktop is used as your Windows shell. If the program gives error messages, try installing the program using the standard Windows PROGRAMMAN.EXE shell. If the installation proceeds normally without any errors but the program fails to run properly, check the following:

If you are using Norton Desktop 3.0, in the Tektronix program group select (single mouse click) the Pattern Editor icon and then select PROPERTIES in the GROUP menu. Select the ADVANCED icon. If the default path and directory was chosen for installation, see if the listed STARTUP DIRECTORY shown is:

(drive on which Windows is installed):\MLPE\

If there is a "\ " after MLPE then edit the entry to remove it.

The correct entry should look like the following:

(drive on which Windows is installed):\MLPE

Choose OK

The same may have to be done for the README icon if an error message indicating that the README cannot be found.

The program will run properly now.

If the program should stop working

If the program has been installed and was working properly and then at a later time fails to run properly, check to see if the "MLPE.INI" file in the WINDOWS directory is still there and is not corrupted. If it is not there, copy the MLPE.INI file from the MLPE directory to the WINDOWS directory. See if the program runs properly. If it is there, it may possibly be corrupted. Rename the file that is there to MLPE.SAV and copy the MLPE.INI file from the MLPE directory to the WINDOWS directory. if the program runs properly, delete the MLPE.SAV file from the WINDOWS directory.

At any time, should any part of the program be corrupted or accidentally deleted, the program can be re-installed.

RS-232 Cabling

If you are using the Editor with a gigaBERT700/1400/1600 and want to use RS-232 to Upload or Download patterns, your RS-232 cable should be wired as shown below:

gigaBERT RS-232 pin number	25 pin Comm Port	9 pin Comm Port
2	2	3
3	3	2
4	4	7
5	5	8
6	6	6
7	7	5

All other pins are not used.

GPIB

This program has been designed to use National Instruments GPIB hardware. It may not work, or work properly with other brands of hardware.

Program Exclusivity

When running the Tektronix Pattern Editor it is suggested that there be no other Windows programs running at the same time in the background. The normal baud rate for operating the program is 9600 baud and other applications that are running at the same time could cause some transferred data to be dropped. To avoid lost data, close any other background applications so that Windows can devote maximum time to the Editor.

Saving patterns

If you open an existing saved pattern from disk and make changes to it, you will be reminded to save the changes before you can close the file or exit the program. If you receive a pattern from a gigaBERT to the Tektronix Pattern Editor you must remember to save the file to disk before closing the file or exiting the program. The program will not remind you to do so.

Depending on the format selected, if you attempt to save a file with any cells not completely filled, the Editor will automatically insert zeros to complete the cell. For example, if the HEX format is chosen and the last cell has an entry of "5", the editor will save the cell with an entry of "05".

If a pattern of more or less than whole bytes is saved, the partial byte will be saved with a whole byte entry whose needed bits are correct and the excess being set to zero(s).

The BACKSPACE key works only within a cell.

Sending Patterns to or from a gigaBERT

Although you can save a pattern with a bit order of either LSB or MSB, you must set the gigaBERT separately to reflect the correct order. The program does not automatically set, or read, the gigaBERT to match the order of the file being sent.

If you should have a problem sending a pattern to a gigaBERT or receiving a pattern from a gigaBERT, there may be a problem with the identification string that is stored in the gigaBERT. Please consult the remote commands section of the respective manual for the instrument. Normally, unless you change the identification strings and prompt, they will remain at the default setting.

Another method for restoring the correct gigaBERT identification string and prompt is to revert the gigaBERT to its default factory configuration. Reverting the instrument to its default condition will destroy any saved patterns and clock frequencies (Tx). To do this, turn the instrument off and then do the following:

For the gB1400 Transmitter: Simultaneously hold in the OUTPUT Clock and PATTERN Clear buttons and turn the instrument on.

For the gB1400 Receiver: Simultaneously hold in the ERROR DETECTION Clear and PATTERN Clear buttons and turn the instrument on.

For the gB700 Transmitter or Receiver: Simultaneously hold in the PATTERN MSB, PATTERN Clear, and VIEW ANGLE buttons and turn the instrument on.

Hold the buttons in until RAM CORRUPTION or DEFAULT SETTING shows in the display. Retry sending or receiving a pattern.

For help

Double click on the Context Help icon (The arrow and ?).

Corrections to the HELP information

The HELP system indicates that only "*filename.pat*" files can be opened. This is not true. Although ".pat" is the default extension and should be used for saving all gigaBERT files, there may be different extensions that may be used for the packetBERT200 depending on the version of firmware of the instrument. All possible filename extensions are listed in the "List of File Type" box in the File Open and File Save menus. Consult your packetBERT200 manual for filenames that are valid.

To Remove the Tektronix Pattern Editor

- 1) Start Windows and remove the Tektronix group and all of its entries.
- 2) Save the configuration.
- 3) Open File Manager
- 4) Delete the following:

The MLPE directory and PATTERNS sub directory and all entries in each.

Delete the MLPE.INI file in the WINDOWS directory.

- 5) The program edits the PATH statement in the AUTOEXEC.BAT file to add the WINDOWS\SYSTEM directory to the path. You can edit the file to remove this statement, or leave it.

There are no other files or changes made by the program.

NOTE:

For technical support or questions pertaining to the installation of this program, call Tektronix at 800-643-2167 or 978-256-6800.

Microsoft Windows is a trademark of Microsoft Corporation.

National Instruments is a trademark of National Instruments Corporation.

WARNING

Read License Agreement Before Opening

Tektronix / Microwave Logic Products

Copyright © Microwave Logic, Inc. All Rights Reserved

Part Number 9508-1388

Version 1.0

IMPORTANT

READ BEFORE OPENING SEALED WRAPPER

This software is provided under license from Microwave Logic, Inc. Retention of this program for more than (30) days, use of the program in any manner, or opening the sealed wrapper surrounding the program constitutes acceptance of the license terms.

CAREFULLY READ THE ENCLOSED SOFTWARE LICENSE AGREEMENT

BEFORE OPENING THE SEALED WRAPPER SURROUNDING THE PROGRAM.

If you cannot agree to the license terms, promptly return the unopened package to Microwave Logic for a full refund. Contact the nearest Microwave Logic Field Office for return assistance.

©Copyright 1995 Microwave Logic, inc. Unpublished-rights reserved under the copyright laws of the United States RESTRICTED RIGHTS LEGEND Use, duplication, or disclosure by the U.S. Government is subject to restrictions as set forth in subparagraph (b)(2) of the Technical Data and Computer Software Commercial Items clause at DFARS252. 211-7015, or in subparagraph (c)(2) of the Commercial Computer Software-Restricted Rights clause at FAR 52.277-19, as applicable . Microwave Logic, Inc. 285 Mill Road, Chelmsford, MA 01824.

**TEKTRONIX, MICROWAVE LOGIC PRODUCTS
SOFTWARE LICENSE AGREEMENT**

THE ENCLOSED PROGRAM IS FURNISHED SUBJECT TO THE TERMS AND CONDITIONS OF THIS AGREEMENT, RETENTION OF THE PROGRAM FOR MORE THAN THIRTY DAYS, OPENING THE SEALED WRAPPER, IF ANY, SURROUNDING THE PROGRAM OR USE OF THE PROGRAM IN ANY MANNER WILL BE CONSIDERED ACCEPTANCE OF THE AGREEMENT TERMS. IF THESE TERMS ARE NOT ACCEPTABLE, THE UNUSED PROGRAM AND ANY ACCOMPANYING DOCUMENTATION SHOULD BE RETURNED PROMPTLY TO MICROWAVE LOGIC, INC. FOR A FULL REFUND OF THE LICENSE FEE PAID.

DEFINITIONS: "Microwave Logic" means Microwave Logic, Inc. a Delaware corporation, with respect to a Program acquired by Customer in the United States, with respect to a program acquired by Customer in Canada.

"Program" means the Microwave Logic software product (executable program and/or data) enclosed with this Agreement or included within the equipment with which this Agreement is packed.

"Customer" means the person or organization in whose name the Program was ordered.

LICENSE. Customer may:

- a. Use the Program under a nontransferable license on a single specified machine.
- b. Copy the Program for archival or backup purposes, provided that no more than one (1) such copy is permitted to exist at any one time.

Each copy of the Program made by Customer must include a reproduction of any copyright notice or restrictive rights legend appearing in or on the copy of the Program as received from Microwave Logic.

Customer may not:

- a. Transfer the Program to any person or organization outside of Customer or the corporation of which Customer is a part without the prior written consent of Microwave Logic.
- b. Export or re-export, directly or indirectly, the program, any associated documentation, or the direct product thereof, to any country to which such export or re-export is restricted by law or regulation of the United States or any foreign government having jurisdiction without the prior authorization, if required, of the Office of Export Administration, Department of Commerce, Washington, D.C. and the corresponding agency of such foreign government.
- c. For object-code Programs only, reverse compile or disassemble the Program for any purpose; or

- d. Copy the documentation accompanying the Program.

For Programs designed to reside on a single-machine and support one or more additional machines, either locally or remotely, without permitting the Program to be transferred to an additional machine for local execution, the additional machines shall be considered within the definition of "single machine". For programs permitting the Program to be transferred to an additional machine for local execution, a separate license shall be required for each such machine with which the Program may be used.

Title to the Program and all copies thereof, but not the media on which the Program or copies may reside shall be and remain with Microwave Logic.

Customer shall pay when due all property taxes that may now or hereafter be imposed, levied or assessed with respect to the possession or use of the Program or this license and shall file all reports required in connection with such taxes.

Any portion of the Program modified by Customer or merged with another program shall remain subject to these terms and conditions.

If the Program is acquired by or for an agency of the U.S. Government, the Program shall be considered computer software developed at private expense and the license granted herein shall be interpreted as granting Customer restricted rights in the Program and related documentation as defined in the applicable acquisition regulation.

THE PROGRAM MAY NOT BE USED, COPIED, MODIFIED, MERGED, OR TRANSFERRED TO ANOTHER EXCEPT AS EXPRESSLY PERMITTED BY THESE TERMS AND CONDITIONS.

UPON TRANSFER OF ANY COPY, MODIFICATION, OR MERGED PORTION OF THE PROGRAM, THE LICENSE GRANTED HEREIN IS AUTOMATICALLY TERMINATED.

TERM. The license granted herein is effective upon acceptance by Customer,

and shall remain in effect until terminated as provided herein. The License may be terminated by Customer at any time upon written notice to Microwave Logic. The license may be terminated by Microwave Logic or any third party from whom Microwave Logic may have obtained a respective licensing right if Customer fails to comply with any term or condition and such failure is not remedied within thirty (30) days after notice thereof from Microwave Logic or such third party. Upon termination by either party, Customer shall return to Microwave Logic, the Program and all associated documentation, together with all copies in any form.

LIMITED WARRANTY. Microwave Logic warrants that the media on which the Program is furnished and the encoding of the Program on the media will be free from defects in materials and workmanship for a period of three (3) months from the date of shipment. If any such medium or encoding proves defective during the warranty period, Microwave Logic will provide a replacement in exchange for the defective medium. Except as to the media on which the Program is furnished, the Program is provided "as is" without warranty of any kind, either express or implied. Microwave Logic does not warrant that the functions contained in the Program will meet Customer's requirements or that the operation of the Program will be uninterrupted or error-free.

In order to obtain service under this warranty, Customer must notify Microwave Logic of the defect before the expiration of the warranty period. If Microwave Logic is unable to provide a replacement that is free from defects in materials and workmanship within a reasonable time thereafter, Customer may terminate the license for the Program and return the Program and any associated materials for credit or refund.

THIS WARRANTY IS GIVEN BY MICROWAVE LOGIC WITH RESPECT TO THE PROGRAM IN LIEU OF ANY OTHER WARRANTIES, EXPRESS OR IMPLIED. MICROWAVE LOGIC AND ITS VENDORS DISCLAIM ANY IMPLIED WARRANTIES OF MERCHANTABILITY OR FITNESS FOR A PARTICULAR PURPOSE., MICROWAVE LOGIC'S RESPONSIBILITY TO REPLACE DEFECTIVE MEDIA, OR REFUND CUSTOMER'S PAYMENT IS THE SOLE AND EXCLUSIVE REMEDY PROVIDED TO THE CUSTOMER FOR BREACH OF THIS WARRANTY.

LIMITATION OF LIABILITY, IN NO EVENT SHALL MICROWAVE LOGIC OR OTHERS FROM WHOM MICROWAVE LOGIC HAS OBTAINED A LICENSING RIGHT BE LIABLE FOR ANY INDIRECT, SPECIAL, INCIDENTAL, OR CONSEQUENTIAL DAMAGES ARISING OUT OF OR CONNECTED WITH CUSTOMER'S POSSESSION OR USE OF THE PROGRAM, EVEN IF MICROWAVE LOGIC OR SUCH OTHERS HAS ADVANCE NOTICE OF THE POSSIBILITY OF SUCH DAMAGES.

THIRD-PARTY DISCLAIMER. Except as expressly agreed otherwise, third parties from whom Microwave Logic may have obtained a licensing right do not warrant the program, do not assume any liability with respect to its use, and do not undertake to furnish any support or information relating thereto.

GENERAL. This Agreement contains the entire agreement between the parties with respect to the use, reproduction, and transfer of the Program.

Neither this Agreement nor the license granted herein is assignable or transferable by Customer without the prior written consent of Microwave Logic.

This Agreement and the license granted herein shall be governed in the United States by the laws of the State of Delaware.

All questions regarding this Agreement or the license granted herein should be directed in the United States to the nearest Microwave Logic Sales Office.

Default Factory Settings

This appendix contains a list of the factory default settings for the PB200. The values listed here are for the various operating parameters that will be used when:

- the unit leaves the factory,
- the non-volatile memory is corrupted,
- the remote command *rst is sent,
- the Factory Default is performed from the front panel.

OUTPUT SIGNAL

Clock Frequency:	205.000000 MHz
External Clock:	OFF
Ext Clock Termination:	GND
Ext Clock Threshold:	0.00 V
External Reference:	OFF
Clock Amplitude:	1.00 V
Clock Offset:	-0.50 V
Data Amplitude:	1.00 V
Data Offset:	-0.50 V
Output Delay:	0.00 nS
Display Control for Clock and Data Output:	ON

ERROR INJECT

Error Inject:	OFF
Error Field:	ALL
Display Control for Error Inject:	AUTO

GENERATOR DATA PATTERN

Output Data Invert:	NORMAL
Pattern Mode:	PRBS
PRBS Pattern:	PRBS 7
MARK Ratio Pattern:	MARK RATIO 1/2
Pre-Amble:	OFF
Payload Mode:	WORD
Payload PRBS Pattern:	PRBS 7
Payload MARK Ratio:	MARK RATIO 1/2
Pattern Sync:	PYLD
Pattern Start Mode:	STOP
Clock GAP:	OFF

ANALYZER DATA PATTERN

Input Data Invert:	NORMAL
Pattern Mode:	PRBS
PRBS Pattern:	PRBS 7
MARK Ratio Pattern:	MARK RATIO 1/2
Pre-Amble:	OFF
Payload Mode:	WORD
Payload PRBS Pattern:	PRBS 7
Payload MARK Ratio:	MARK RATIO 1/2

INPUT SIGNAL

Clock Input:	SINGLE-ENDED
Clock Termination:	GND
Clock Threshold:	0.00 V
Clock Source:	INT
Data Input:	SINGLE-ENDED
Data Termination:	GND
Data Threshold:	0.00 V
Display Control for Input Signal:	ON
Input Delay:	0.00 nS
Startup Delay:	0 Clocks

Display Control for Prop Delay: ON

ERROR CONTROL

Slip Control: ENABLE

Error Mode: ALL

Synchronization Threshold: 1 (2.5E-1)

Display Control for

Clock Frequency: ON

Large Error Rate: OFF

Large Error Count: OFF

Ones Error: ON

Zeros Error: ON

SLIDING WINDOW

Window Mode: BITS

Window Time Length: 00:00:10

Window Bit Length 1E+09

End-of-Window Report OFF

Data Display Mode: TOTALIZE

TEST CONTROL

Test State: STOP

Test Length: 00:00:10

Test Mode: UNTIMED

Error Threshold: 1E-06

On Error Squelch: OFF

Test Report: OFF

AUTO SEARCH

Auto Search:	DISABLE
Auto Clock Threshold:	ENABLE
Auto Data Threshold:	ENABLE
Auto Deskew Delay:	ENABLE
Auto PRBS Pattern:	DISABLE
Auto MARK Pattern:	DISABLE
Auto WORD Pattern:	DISABLE
Auto MIXED Pattern:	DISABLE
Auto Polarity:	DISABLE
Auto Search Pattern Time:	250 ms
MODE:	ONCE/RESTART GENERATOR

EYE WIDTH

Eye Width State:	OFF
Eye Width Mode:	BER
Eye Width Sample Size:	1E6
Eye Width Threshold #1:	1E-4
Eye Width Extrapolation:	OFF
Eye Width Threshold #2:	1E-5
Eye Width Threshold #3:	1E-10

MISCELLANEOUS

Display Contrast:	5
Monitor:	LCD
Remote Debug Mode:	OFF

RS-232C (*RST does not affect)

Prompt:	PB200>
Baud Rate:	9600
Parity:	EVEN
Character Size:	7
Stop Bits:	1
EOL:	CR/LF
XON/XOFF:	OFF
Echo:	ON

GPIB (*RST does not affect)

Address:	14
GPIB Terminator:	EOI/LF
GPIB Bus Control:	TALK/LISTEN
Remote Header:	ON

Reports

Reports

1995/11/28 12:16:00	Errors	Rate
Bits: 0 Freq: 0.000000MHz	All	0 0.00E-00
Error Mode: ALL Patt: PRBS7	1's	0 0.00E-00
Sync Loss: OFF Phase: OFF	0's	0 0.00E-00

End-of-Window Reports

When enabled, an End-of-Window report will occur once for each period equal to the window length. The results of an End-of-Window report are based on a sliding interval T, where T is set in terms of bits or time. Use the REPORT parameter in the SLIDING WINDOW menu to enable or disable these reports. An example of the End-of-Window report is shown below.

1995/11/05 12:02:20	Error	Rate
Bits:2000000000 Freq: 200.000002 MHz	All	0 0.00E-08
Error Mode: ALL Patt: PRBS 7	1's	0 0.00E-08
Sync Loss: OFF Phase: OFF	0's	0 0.00E-08

End-of-Test Reports

When End-of-Test reports are enabled, one End-of-Test report will be generated each time the end of a Test interval is reached. This can occur automatically, when timing mode is set to Timed or Repeat, or manually when the user stops any test. Use the TEST REPORT parameter in the TEST CONTROL menu to enable or disable End-of-Test reports. An example End-of-Test report is shown below.

packetBERT-200	TEST SUMMARY	1995/11/05 12:11:56
TEST MODE: TIMED	ERROR MODE: ALL	ERROR THRES: 1E-06
DATE	TIME	ALARMS
START:	1995/11/05 12:10:56	US: 0 0.0%
STOP:	1995/11/05 12:11:56	SES: 0 0.0%
ELAPSED:	000-00:01:00	TES: 0 0.0%
		ES: 0 0.0%
		EFS: 60 100.0%
		DM: 0 0.0%
	ERRORS RATE	
ALL ERR:	000000000 0.0E-10	
1's ERR:	000000000 0.0E-10	
0's ERR:	000000000 0.0E-10	TOTAL BITS: 12000000000

On Error Reports

When enabled, On Error reports are generated for each second in which the error rate is above the Test Error Threshold. Note that On Error reports can be squelched after reports are generated on 10 consecutive seconds, by enabling the ON ERROR SQUELCH parameter. This is recommended for unattended operation since these reports can generate a lot of paper. An example On Error report is shown below.

packetBERT-200	TEST RESULTS	1995/11/05 12:25:15	
TEST MODE: TIMED	RROR MODE: ALL	ERROR THRES: 1E-06	
12:25:23 ERRS: 95359883	RATE: 4.77E-01	SYNC_LOS	
12:25:24 ERRS: 99115579	RATE: 4.96E-01	SYNC_LOS	
12:25:25 ERRS: 99115580	RATE: 4.96E-01	SYNC_LOS	
12:25:26 ERRS: 64105864	RATE: 3.21E-01	SYNC_LOS PHA_ERR	

Cleaning Instructions

Clean the PB200 often enough to prevent dust and dirt from accumulating. Dirt acts as a thermal insulator, preventing effective heat dissipation, and can also provide high-resistance leakage paths between conductors or components in a humid environment.

Cleaning the Exterior

Clean the dust from the outside of the instrument with a soft, clean cloth or small brush. A brush is especially useful for removing dust from around the buttons and connectors. Remove hardened dirt with a soft cloth dampened with a mild detergent and water solution. Do not use abrasive cleaners.

Cleaning the CRT

Clean the light filter and CRT face with a soft, lint-free cloth dampened with denatured alcohol. Do not use abrasive cleaners.

Cleaning the Interior

Interior cleaning and maintenance should be performed by qualified service personnel only.

Glossary

Address

A number specifying a particular user device attachment point... The location of a terminal, a peripheral device, a node, or any other unit or component in a network...A set of numbers than uniquely identifies something - a location in computer memory, a packet of data traveling through a network.

Analog-to-Digital Converter

A device that converts an analog signal, that is, a signal in the form of a continuously variable voltage or current, to a digital signal, in the form of bits.

Attenuation

A decrease in magnitude of current, voltage, or power of a signal in transmission between points.

Attenuator

An electronic transducer, either fixed or adjustable, that reduces the amplitude of a wave without causing significant distortion.

Bandwidth

The difference between the limiting frequencies of a continuous frequency spectrum. The range of frequencies handled by a device or system.

BER

An acronym for Bit Error Ratio (or Rate). The principal measure of quality of a digital transmission system. BER is defined as:

$$\text{BER} = \text{Number of Errors} / \text{Total Number of Bits}$$

BER is usually expressed as negative exponent. For example, a BER of 10^{-7} means that 1 bit out of 10^7 bits is in error.

BER Floor

A limiting of the bit-error-ratio (BER) in a digital fiber optic system as a function of received power due to the presence of signal degradation mechanisms or noise.

Binary

A numbering system that allows only two values, zero and one, (0 and 1). Binary is the way most computers store information., in combination of ones and zeros. Voltage on. Voltage off. See also: Bit.

Bit

A binary digit, the smallest element of information in binary system. A 1 or 0 of binary data.

Bit Error

An incorrect bit. Also known as a coding violation.

Bit Rate

The number of bits of data transmitted over a phone line per second.

Byte

A unit of 8 bits.

Channel

A communications path or the signal sent over a channel. Through multiplexing several channels, voice channels can be transmitted over an optical channel.

Clock

1. An electronic component that emits consistent signals that paces a computer's operations. 2. An oscillator-generated signal that provides a timing reference for a transmission link. A clock provides signals used in a transmission system to control the timing of certain functions, such as the duration of signal elements or the sampling rate. It also generates periodic, accurately spaced signals used for such purposes as timing, regulation of the operations of a processor, or generation of interrupts. A clock has two functions: to generate periodic signals for synchronization on a transmission facility, and to provide a time base for the sampling of signal elements. In computers, a clock synchronizes certain procedures, such as communication with other devices.

Error Detection

Checking for errors in data transmission. A calculation is made on the data being sent and the results are sent along with it. The receiving station then performs the same calculation and compares its results with those sent. ...Code in which each data signal conforms to specific rules of construction so that departures from this construction in the received signals can be automatically detected. Any data detected as being in error is either deleted from the data delivered to the destination, with or without an indication that such deletion has taken place, or delivered to the destination together with an indication that it has been detected as being in error.

Error Rate

The ratio of the number of data units in error to the total number of data units.

ES

An acronym for Errored Second. A second with at least one error.

GPIB

A physical layer interface standard for the interconnection of equipment.

Line

The portion of a transmission line between two multiplexers.

LOF

An acronym for Loss of Frame.

LOS

An acronym for Loss of Signal.

Multi-Channel Cable

An optical cable having more than one fiber.

Noise

Unwanted signals that combine with and hence distort the signal intended for transmission and reception.

Residual error rate

The error rate remaining after attempts at correction are made.

RS-232C

A physical layer interface standard for the interconnection of equipment.

Rx, Receiver

An abbreviation for Receiver

A detector and electronic circuitry to change optical signals to electrical signals.

Tx, Transmitter

An abbreviation for Transmitter

A driver and source used to change electrical signals to optical signals.

Index

-A-

- AC Line, 2-33
- Accessories, 1-6
- Analyzer Inputs, 2-13
- ANALYZER section on front panel, 2-29
- Analyzer Soft Keys, 3-14
 - Auto Search, 3-14, 3-21
 - Clock Input, 3-15
 - Data Input, 3-15
 - Data Pattern, 3-18
 - Error Mode, 3-28
 - Eye Width, 3-14, 3-26
 - Pattern Copy, 3-32
 - Pattern Edit, 3-29
 - Sliding Window, 3-33
 - Slip Control, 3-14
 - Test Control, 3-34
 - Test Results, 3-35
- Applications, 1-5
- Applications, Examples of, 3-37
 - Basic BERT Testing, 3-38
 - Mixed Mode Patterns, 3-43
 - Satellite Test & Simulation, 3-37
- Auto Search, function, 2-15

-B-

- BER Eye Width Measurement, 2-18
- BER Mode, 2-19
- BERT Technology, 2-2
- BNCs, Rear Panel, 2-34

-C-

- Cleaning Instructions, *Appendix-37*
- Clock Gap, PB200, 2-8
- Continuous/Start Mode, PB200, 2-9

-D-

- Default Factory Settings, *Appendix-29*
- Diskette File Format, *Appendix-16*

-E-

- Entry Keys, 2-22
- Error Field, 2-17
- Error Injection, 2-5
- Error Rate, 2-16
- Error Rates, PB200, 2-20
- Error, Frequency Measurements, 2-16
- Extrapolate "ON", 2-19
- EYE WIDTH Measurements, 1-8

-F-

- Features & Capabilities, 1-5
- First Time Operation, 1-10
 - Change the Analyzer Data Input Threshold, 1-13
 - Change the Data Pattern, 1-14
 - Change the Generator Data Amplitude, 1-13
 - Change the Generator Frequency, 1-12
 - Clear the Analyzer History Status, 1-11
 - Clear the Errors, 1-12
 - Connect the Generator BNC to the Analyzer BNC, 1-11
 - Download a Pattern from Diskette, 1-16
 - Inject an Error, 1-12
 - Load a Mixed Mode Pattern from Floppy Disk, 1-17
 - Other Examples of Pattern and Setup Files, 1-19
 - Power On/Default, 1-10
 - Setup for Mixed Mode Operation, 1-15
 - Terminate Unused Generator Outputs, 1-11
- Floppy Drive, 2-29
- Frequency, 2-16

-G-

- Gap Clock, 1-8
- Generator Soft Keys, 3-3
 - Clock Frequency, 3-3
 - Clock Output, 3-4
 - Data Output, 3-5
 - Data Pattern, 3-7
 - Error Control, 3-10
 - Ext Clock, 3-6
 - Pattern Copy, 3-13
 - Pattern Edit, 3-11
 - SYNC, 3-9

-I-

- Interfaces, 1-9
- Internal Clock Source, 2-7

-L-

- Line Fuse, Changing, 2-32
- Loading and Storing Pattern Files, *Appendix-9*

-M-

- Menu Maps, 3-36
- Menus and Displays, 3-2

-O-

- Output Amplifiers, 2-5

-P-

Packet Bit Error Rate Tester, what is?, 1-6
Pattern Editor Requirements & Features,
Appendix-19
Pattern Generator, PB200, 2-3
PATTERN section on front panel, 2-28
Phase Mode, 2-18
Power Switch, 2-22
PRBS Patterns, *Appendix-15*

-R-

Rear Panel, 2-30
Reference Pattern Generator, 2-14
Reports, *Appendix-34*
Signal Analysis, 1-8

-S-

Simultaneous Measurements, 2-16
SLIP Enable/Disable, 2-14
Specifications - PB200, *Appendix-2*
Sync Operation with Straight PRBS data,
Example of, 2-12
Synchronization Not Required, 2-15
Synchronization, 2-14
Synchronization, Startup and Propagation Delay,
2-10
Synchronize to an incoming pattern, How does
PB200?, 2-10
System Performance Verification, *Appendix-5*

-U-

UTILITY section on front panel, 2-22
 Factory Default, 2-25
 GPIB, 2-26
 Left Display Control, 2-23
 Monitor, 2-27
 Print, 2-23
 Remote, 2-26
 Right Display Control, 2-24
 RS-232, 2-25
 Time Date, 2-27

