

Prototyping products:
first issue

apw

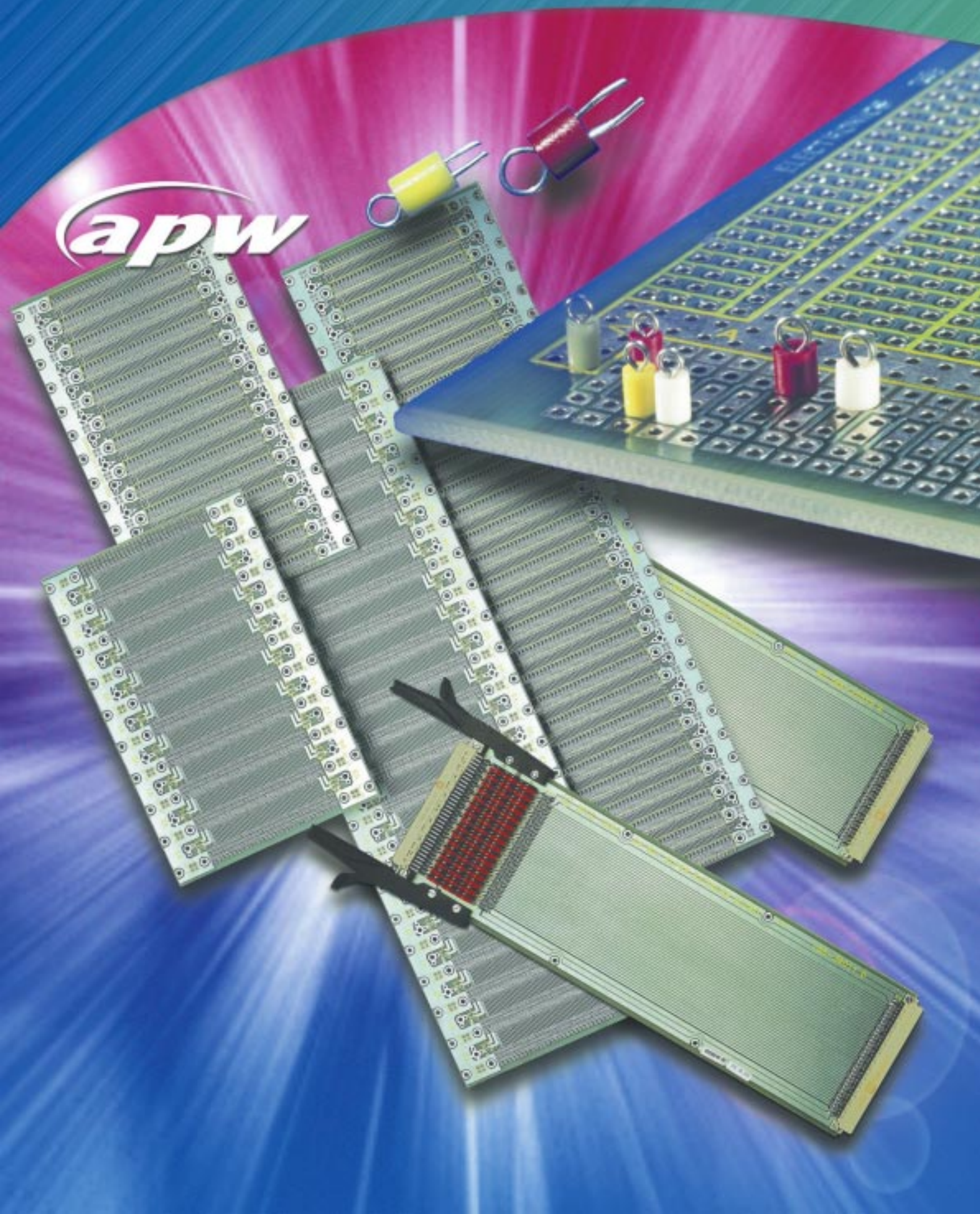

Introduction: APW Electronic Solutions

APW Electronic Solutions, which is responsible for the manufacture and marketing of the prototyping product range, is a focused business unit within APW, providing a global backplane, hardware and system integration capability, servicing multinational, high technology electronics businesses.

Major centres of excellence, located on both the east and west coasts of the United States, in northern Germany and the United Kingdom, provide a powerful combination of core competencies embracing engineering, design, assembly and test of backplanes and systems incorporating power supplies and thermal management functionality.

The backplane and systems facilities have long been at the forefront of technological development, and their commitment to the latest high technology boards is demonstrated by the fact that they currently manufacture some of the most advanced backplanes and systems available.

All APW Electronic Solutions facilities are fully equipped with some of the latest electronic design and manufacturing systems, enabling customers to access a "virtual" factory for the procurement of product.

The organisation is dedicated to being a leading provider of a comprehensive range of standard and custom product, borne from the integrated design, manufacturing and service capabilities, enabling it to provide OEMs with rapid deliveries at competitive prices.

At APW Electronic Solutions every customer is a priority and contact is maintained by means of the organisation's own dedicated Sales and Applications Teams, which are able to draw upon the global resources of APW.

APW ELECTRONIC SOLUTIONS: LOCATIONS

Shown at right, from top to bottom, are the APW Electronic Solutions sites from which prototyping products can be ordered.

- America: *Hudson, New Hampshire*
- Britain: *Hedge End, Hampshire*
- Denmark: *Værløse*
- France: *Beauvais*
- Germany: *Bremen*
- Italy: *Turin*
- Sweden: *Stockholm*

Full contact details for these locations can be found on the back cover of this publication.



Index

Eurocard prototyping boards	3 - 12
<i>Critical Eurocard Dimensions</i>	3
PTH Microboard	4
Single/double sided Microboard	5
Three plane high density DIP board	6
KM6 DIP board	7
KM6 Eurocard: Veroboard pattern	7
Veroboard with colander ground plane	8
Square pad board	8
Square pad board with colander ground plane	9
PTH Square pad board	9
Budget Eurocard	10
DIP board	10
Plug-in Veroboard	11
Veroboard: metric and imperial pitch	12
Plain boards: metric and imperial pitch	12
Non-eurocard prototyping boards	13 - 15
Veroboard: single sided copper	13
Verostrip: single sided copper	13
Plain boards	14
DIP Breadboard	14
DIP Plug-in boards: for single and double sided connectors	15
Eurocard extender boards	16- 19
Double sided extender board	16
60mm daughter board extender	16
Standard and Super PTH extender boards	17
Multilayer extender boards	18
Multilayer uncommitted extender	19
Eurocard development backplanes	20 - 22
Microbus backplane	20
Double sided uncommitted backplane	21
Multilayer Microbus backplane	22
Accessories	23 - 30
Verowire	23
Card support/ejector mechanism	23
Spot face cutter	23
Terminal assemblies	24
Card handles	25 - 26
Terminal, socket and wirewrapping pins	27 - 30

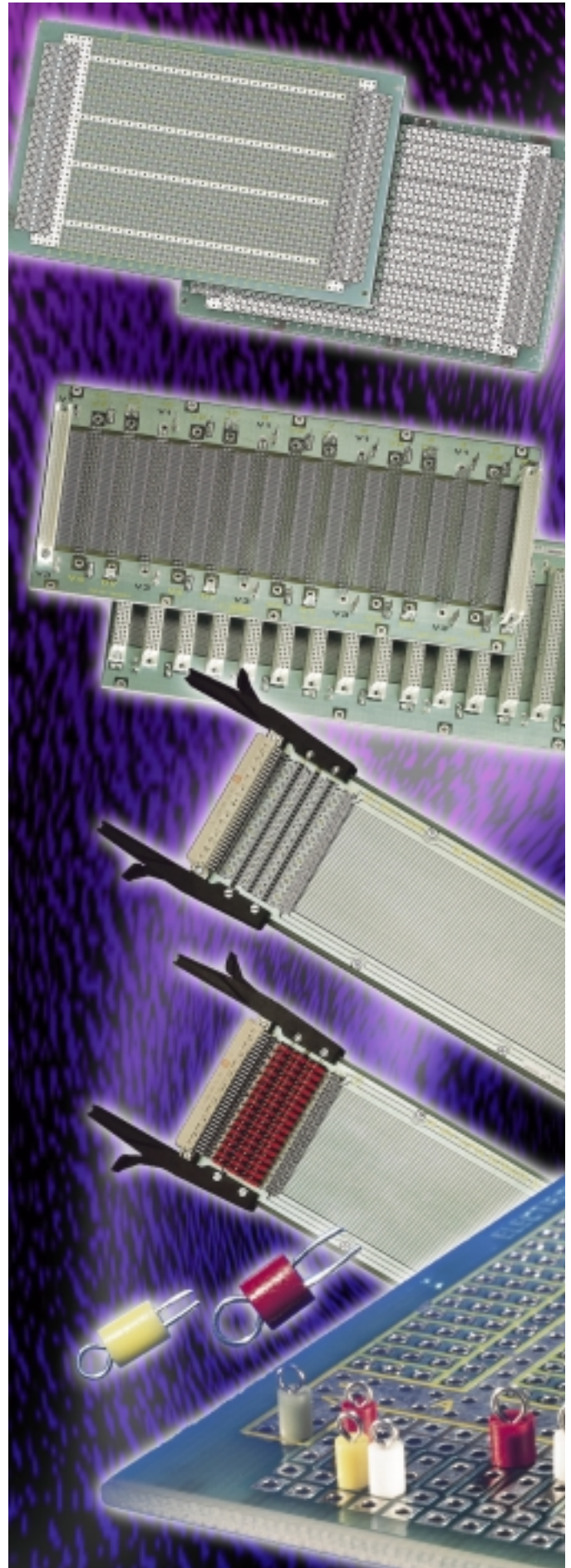

Critical Eurocard dimensions

CRITICAL EUROCARD DIMENSIONS

A 2,5mm wide border is necessary - top and bottom of printed circuit boards - to allow clearance for guides and for mounting into plug-in unit guide rails. On the double height Eurocard, owing to the overall size and position of the connectors, it is recommended that when fitting components to front panels the grid as laid out is adopted. This will allow consistency between 3U and 6U height front panels.

List of undrilled pads which appear on most Eurocards

- E. DIN 41612 connector mounting
- F. DIN 41617 connector mounting
- G. Card ejectors
- H. Card handle Type A - 45,72 centres
- K. Card handle Type C
- L. Card handle Type B - 30,48 centres
- M. Module mounting
- N. Card mounting brackets KM4 and KM6, card ejector KM6
- O. KM4 module mounting extended with "M" holes
- P. Module mounting 220 cards only
- R. Flexible card handle Type E

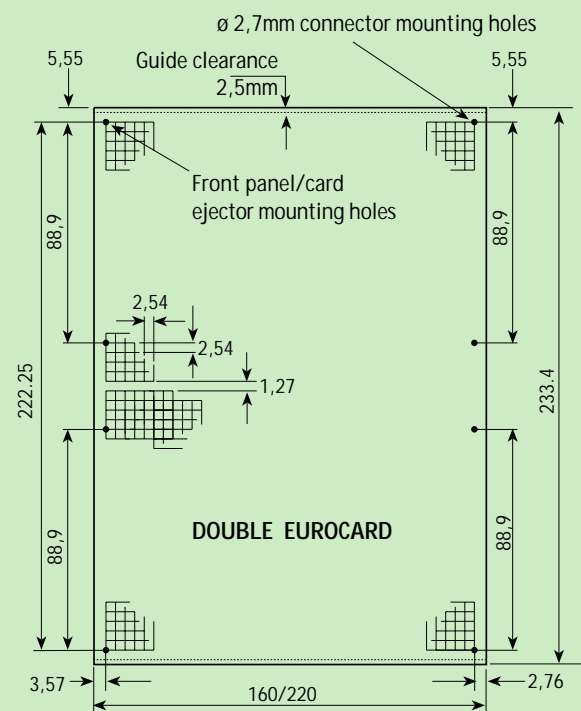
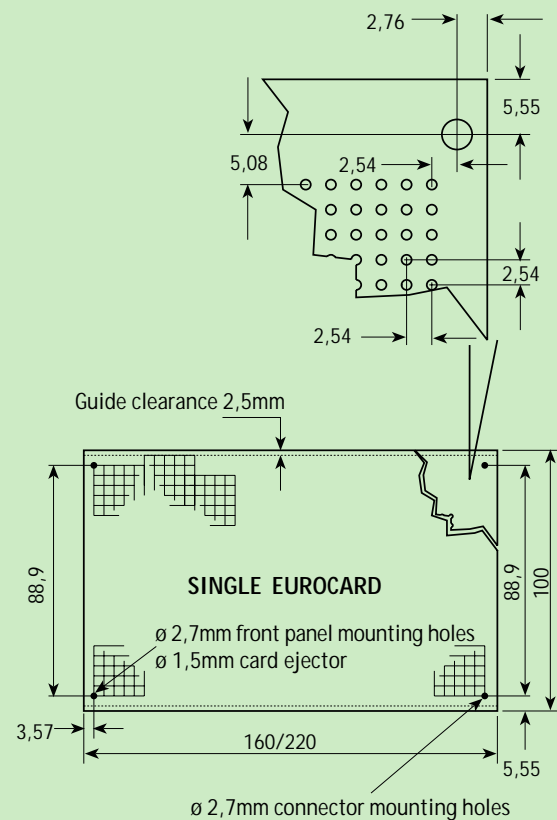

Prototyping boards

PTH MICROBOARD

Features

- Reliability of plated through holes
- DIN 41494 (KM6-II) compatible
- Medium packing density
- DIN 41612 connector position, up to 96/96 ways, front and rear
- Solder resist protection to component side of board
- Two Vcc power rails and a 0V ground plane
- Grid print to aid component layout
- Microbus backplane compatible

Application

Specifically designed for microprocessor applications where high reliability, freedom from crosstalk and interface capability is a requirement. Fully compatible with DIN 41494 (KM6-II etc.) and equally suited to soldered or wirewrapped interconnections. When soldering a PTH board, capillary action draws the solder around the component leads forming extremely solid, reliable joints, particularly important in high vibration applications.

Screening

A maximum copper colander 0V ground plane is provided on the component side of the board. It is recommended that this side is used for interwiring with looms lying flat on the ground plane surface. This will reduce crosstalk from signal lines coupling directly to the ground plane.

Board specification

Board type	Epoxy glass
PTH	BS 4584 EP-GC-Cu 3 FR4
Max. working temp.	155°C
Nom. board thickness	1,6mm
Laminate copper thickness	35mm or 1oz/ft ² or 305g/m ²
Plated copper	25µm
Tin lead	10µm
Total	70µm

Note: bare boards are UL V-0 recognised components file number E116551. Bare boards are approved to BS 9762

Ordering information

Description: PTH Microboard

Board dimensions	7,62 pitch IC DIP rows/pads	15,24 pitch IC DIP rows/pads	Order code
100 x 160	4/44	4/44	222-2991F
100 x 220	4/67	4/67	222-2992B
233,4 x 160	11/44	17/44	222-2993J
233,4 x 220	11/67	17/67	222-2994E
366,8 x 220	17/67	10/67	222-27561D

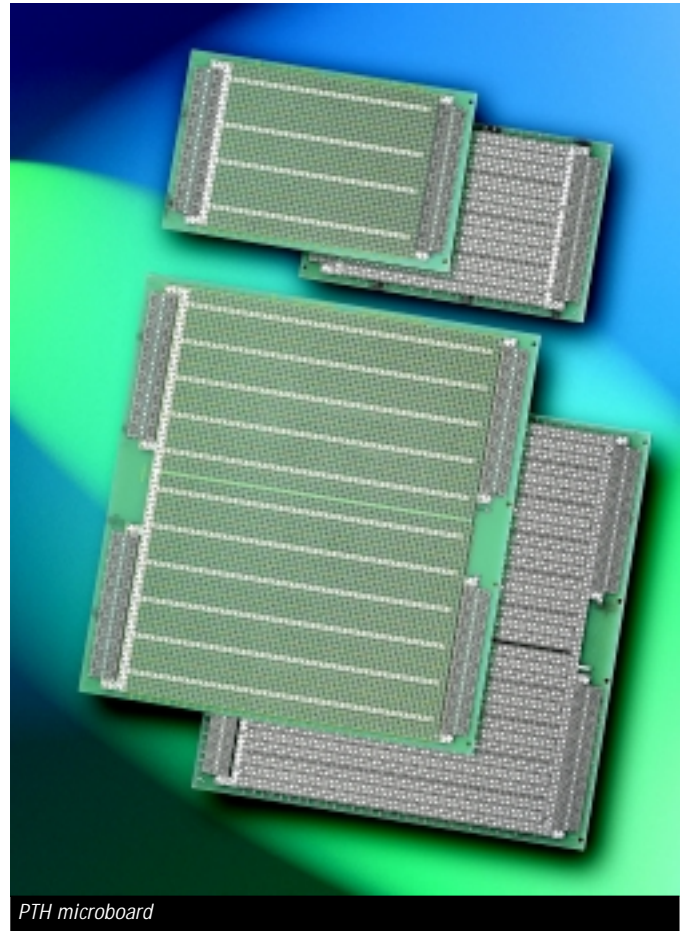

PTH microboard

Non-PTH Board

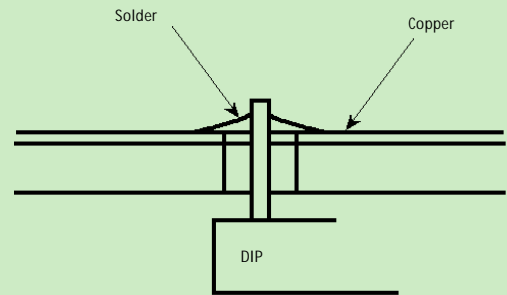

PTH Board

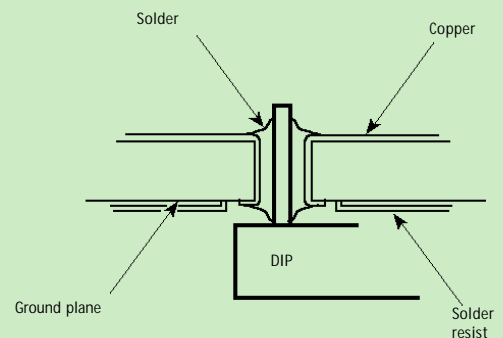

Prototyping boards

MICROBOARD DOUBLE SIDED

The forerunner of the PTH microboard, this range of boards finds similar applications in all but high reliability of plated through holes and restricted use of DIN 41612 connectors up to 64/96 ways only.

Features

- DIN 41494 (KM6-II) compatible
- Medium packing density
- DIN 41612 connector up to 64/96 ways, front and rear
- Solder resist protection to component side of board
- Grid print to aid component layout
- Microbus backplane compatible
- 0V ground plane screen

Ordering information

Description: Double-sided Microboard

Board dimensions	7,62 pitch IC DIP rows/pads	15,24 pitch IC DIP rows/pads	Order code
100 x 160	4/46	4/46	10-2845B
233,4 x 220	11/69	7/69	10-2858C

MICROBOARD SINGLE SIDED

This low cost Eurocard has no 0V ground plane on the component side, but is otherwise identical to the double sided microboards.

Features

- Medium packing density
- DIN 41612 connector pattern, up to 64/96 ways, front and rear
- Grid print to aid component layout
- Microbus backplane compatible

Note: DIN 41494 (KM6-II) compatible

Ordering Information

Description: Single-sided Microboard

Board dimensions	7,62 pitch IC DIP rows/pads	15,24 pitch IC DIP rows/pads	Order code
100 x 160	4/46	4/46	10-27563H

*Note: Hole grid 2,54 x 2,54mm Hole dia. 1,02mm
N.B. 3,81mm centre gap on double height boards*

Board specification

Board type	Epoxy glass
Double/single sided copper	BS 4584 part 16
Max. working temp.	155°C
Nom. board thickness (inc. copper)	1,6mm
Copper thickness	35µm or 1oz/ft ² or 305g/m ²

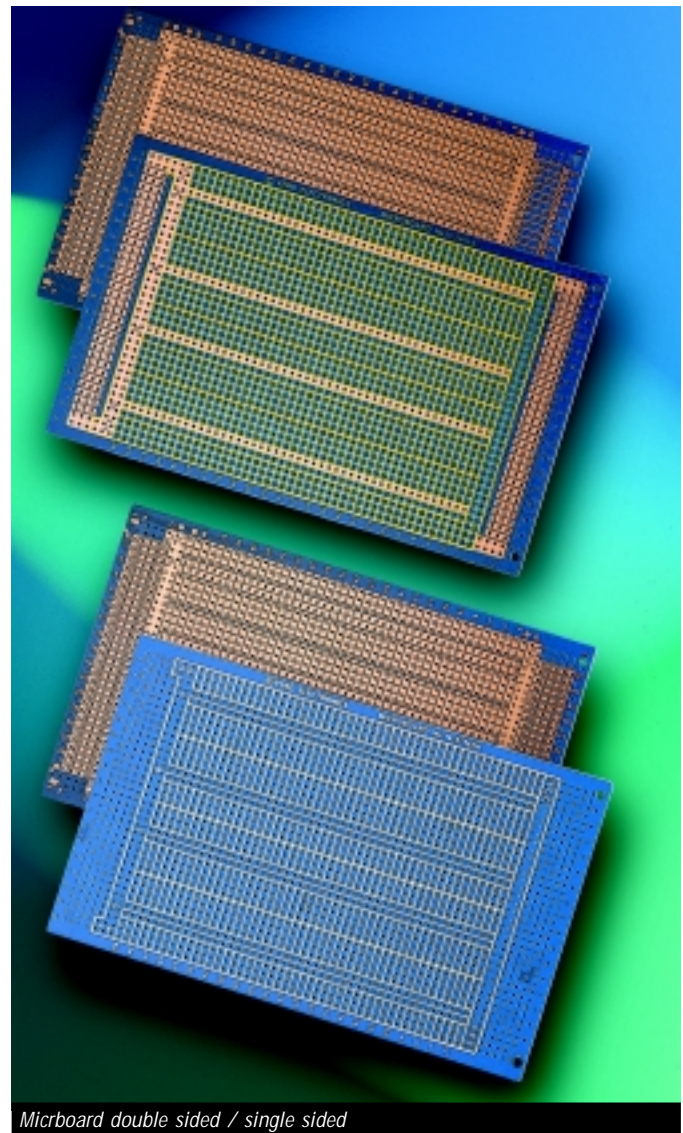

Micrboard double sided / single sided

Prototyping boards

3 PLANE HIGH DENSITY DIP BOARD

Features

- High packing density
- Two Vcc and one 0V power rail options
- DIN 41494 (KM6-II) compatible
- DIN 41612 connector pattern, up to 64/96 ways
- Microbus backplane compatible

Ideal for high density circuitry using wirewrapping, hardwiring or Verowire interconnection techniques. The board features two power rail options, either as two 0V or one Vcc and a ground plane on the component side. Power rails run between rows of 7,62 pitch integrated circuits allowing end-to-end stacking for increased packing density.

Backplane compatible

By utilising a simple track break facility to isolate Vcc from pin 32, high density DIP boards are fully compatible with the APW Microbus range of backplanes.

Ordering information

Description: 3 Plane high density DIP board

Board dimensions	7,61 pitch IC DIP rows/pads	15,24 pitch IC DIP rows/pads	Order code
100 x 160	5/53	4/53	10-0581B

Note: hole grid 2,54 x 2,54mm Hole dia. 1,02mm

Note: 3,81mm gap on double height boards

Board specifications

Board type	Epoxy glass
Double/single sided copper	BS 4584 part 16
Max. working temp.	155°C
Nom. board thickness (inc. copper)	1,6mm
Copper thickness	35µm or 1oz/ft ² or 305g/m ²

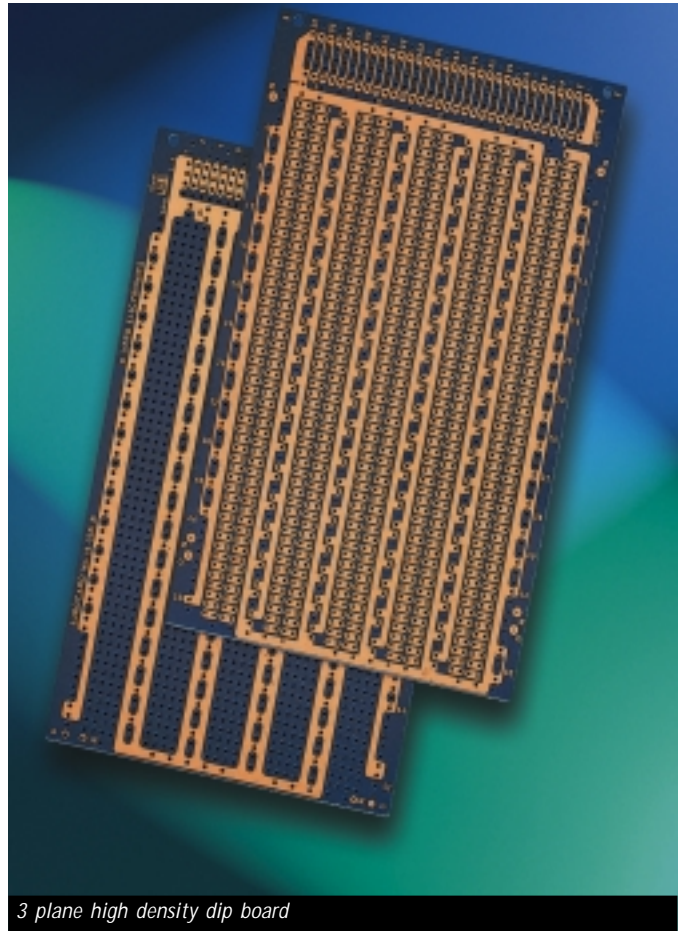

3 plane high density dip board

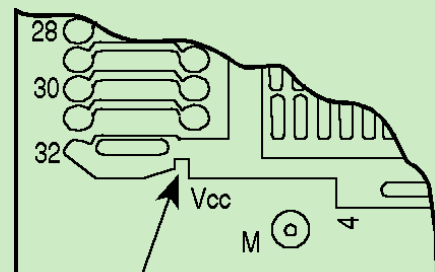

Track Break Position

Prototyping boards

KM6 DIP BOARD

A low density board designed for hard wiring of integrated circuits. 0V and Vcc rail patterns are duplicated on the component side of the board giving increased power distribution. Connector pattern at rear edge of board allows input/output via ribbon cable headers.

Features

- DIN 41494 (KM6-II) compatible
- DIN 41612 connector position, up to 64/96 ways
- Rear end input/output facility
- Grid print to aid component layout
- Microbus backplane compatible
- Ample room for wiring looms and/or discrete components

Note: The board pattern is turned through 90° on double height Eurocard versions in order to maximise packing density.

Ordering information

Description: KM6 DIP Board

Board dims	7,62 pitch IC DIP rows/pads	15,24 pitch IC DIP rows/pads	Base material	Order code
100 x 160	4/32	3/32	Epoxy	10-2446C

Note: hole grid 2,54 x 2,54mm Hole dia. 1,02mm

KM6 EUROCARD VEROBOARD PATTERN

A unique board giving the advantages of Veroboard with the flexibility of Eurocard and DIN 41612 connectors. Primarily used for hard wiring of discrete components, typically in analogue circuits, it is equally useful where a number of common bus or signal lines are required. For wirewrapping applications a 3,81mm gap on the double height boards maintains board patterns on grid with adjacent connectors.

Features

- DIN 41494 (KM6-II) compatible
- Ideal for hard wiring of discrete components
- Grid pattern to aid component layout
- Microbus backplane compatible
- Eurocard sizes

Ordering information

Description: KM6 Eurocard, Veroboard Pattern

Board dims	Tracks	Holes per track	Base material	Order code
100 x 160	34	52	Epoxy	10-2449K
100 x 220	34	77	Epoxy	10-27558D

Note: Hole grid 2,54 x 2,54mm Hole dia. 1,02mm

Note: 3,81mm gap on double height versions

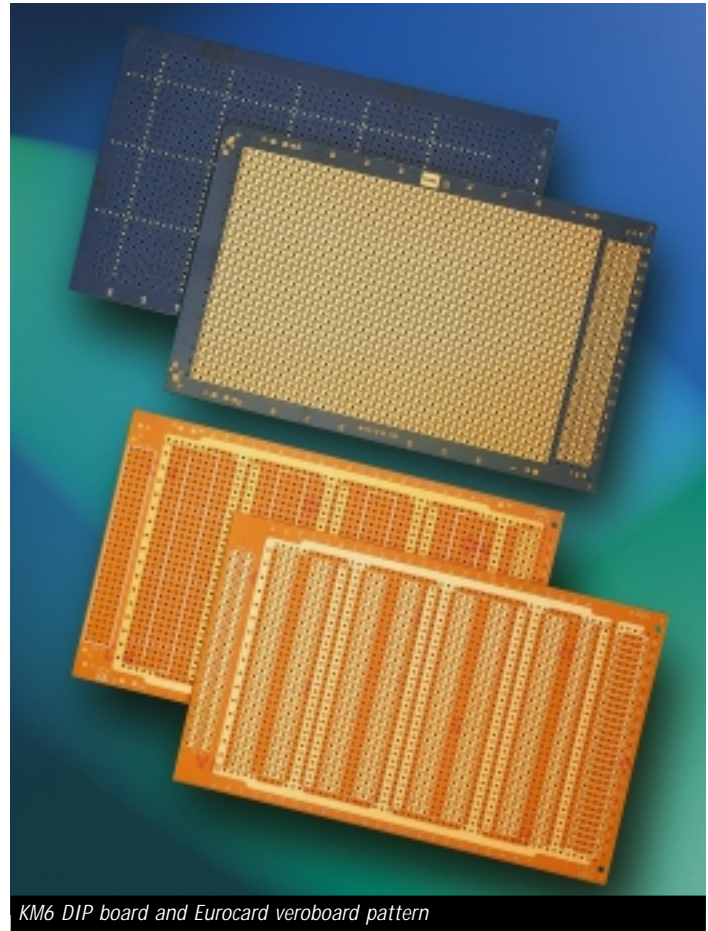

KM6 DIP board and Eurocard veroboard pattern

Board specification

Board type	Epoxy	SRBP
Single/double sided copper	BS4584 part 16	BS 4584 part 5
Max. working temp.	155°C	97°C
Nom. board thickness	1,6mm (inc.copper)	
Copper thickness	35µm or 1oz/ft ² or 305g/m ²	

Prototyping boards

VEROBOARD PATTERN WITH COLANDER GROUND PLANE

Similar in use to the standard Veroboard pattern but offering the advantages of full 0V colander ground plane to provide maximum screening on the component side of the board.

Features

- DIN 41494 (KM6-II) compatible
- Ideal for hard wiring of discrete components
- Colander ground plane for maximum screening
- DIN 41612 connector up to 64/96 ways
- Microbus backplane compatible

Ordering information

Description: Veroboard pattern, with colander ground plane

Board dimension	Tracks	Holes/ tracks	Base material	Order code
100 x 160	34	54	Epoxy glass	03-2990F

Note: Hole grid 2,54 x 2,54mm, hole dia. 1,02mm and 3,81mm gap on double height boards

SQUARE PAD BOARD

A range of boards offering total flexibility and maximum density of wirewrapped circuitry. Any size of wirewrapping DIP socket or terminal pin can be accepted in either X or Y planes. Vcc and 0V rails may be daisy chained from post to post around the board eliminating the need to stake pins in power rails as on other types of board.

Features

- Maximum packing density
- Total flexibility using hard wire or wirewrapping techniques
- DIN 41494 (KM6-II) compatible
- DIN 41612 connector pattern up to 96/ 96 ways
- Grid references to both sides of board to aid component layout and to assist wiring
- Microbus backplane compatible

Note: Component grids compatible with connectors. Board 03-0111L has a full board pattern aligned with the lower connector giving a 1,27mm offset between the top and bottom connector patterns.

Ordering information

Description: Square pad board

Board dimensions	No. of Pads		Base material	Order code
	width	length		
100 x160	34	54	Epoxy glass	03-0026J
100 x 220	34	77	Epoxy glass	03-27555K
233,4 x 160	85	52	Epoxy glass	03-0111L
233,4 x 160	86	52	Epoxy glass	03-27556F*
233,4 x 220	86	75	Epoxy glass	03-27557B*

*Note: Hole grid 2,54 x 2,54mm Hole dia. 1,02mm *3,81mm gap on these boards*

Board specifications

Board type	Epoxy glass
Double sided copper	BS 4584 part 16
Max. working temp.	155°C
Nom. board thickness (inc. copper)	1,6mm
Copper thickness	35µm or 1oz/ft ² or 305g/m ²

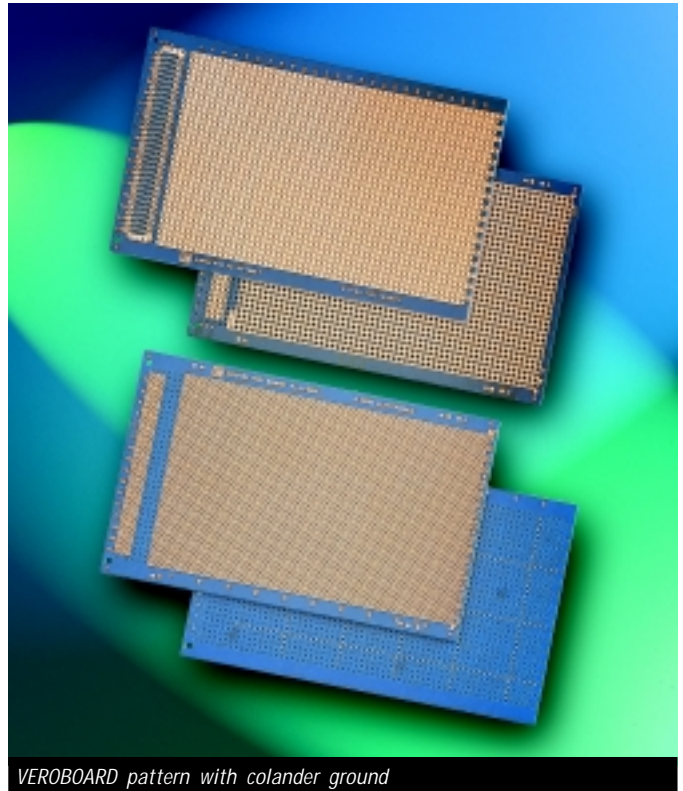

VEROBOARD pattern with colander ground

Prototyping boards

SQUARE PAD BOARD WITH COLANDER GROUND PLANE

A single height Eurocard similar to the standard square pad board but offering the additional advantage of 0V colander ground plane.

Features

- Maximum packing density
- Total flexibility using hard wire or wire wrapping techniques
- Colander ground plane for maximum screening
- DIN 41494 (KM6-ⅠⅠ) compatible
- DIN 41612 connector pattern up to 96/96 ways
- Grid references to both sides of board to aid component layout and to assist wiring
- Microbus backplane compatible

Board specification

Board type	Epoxy glass
Double sided copper	BS 5484 part16
Max. working temp.	155°C
Nom. board thickness	1,6mm(inc. copper)
Copper thickness	35µm or 1oz/ft ² 305g/m ²

Ordering information

Description: Square pad board with colander ground plane

Board dimensions	No. of Pads		Base material	Order code
	width	length		
100 x 160	34	54	Epoxy glass	03-2989L

PTH SQUARE PAD BOARDS

By having plated through holes, these boards are able to offer the same high density and flexibility as the square pad Eurocards but for hard wiring applications. A high level of interfacing may be achieved with boards able to accept 96/96 way DIN 41612 connectors.

Power rails are provided along the length of the board and a colander ground plane affords maximum screening to the component side of the board.

Features

- Maximum packing density
- Total flexibility using hard wire or wirewrapping techniques
- DIN 41494 (KM6-ⅠⅠ) compatible
- DIN 41612 connector pattern up to 96/96 ways, front and rear
- Solder resist protection to component side of board

Board specification

Board type	Epoxy glass
Plated through hole	BS 4584 Ep-GC-Cu-FR4
Max. working temp.	155°C
Nom. board thickness	1,6mm
Laminate copper thickness	35µm or 1oz/ft ² or 305g/m ²
Plated copper	25µm
Tin lead	10µm
Total	70µm

Ordering information

Description: PTH Square pad boards

Board dimensions	No. of Pads		Base material	Order code
	width	length		
100 x 160	32	48	Epoxy glass	222-26492L
100 x 220	32	71	Epoxy glass	222-53134H
233,4 x 160	70	48	Epoxy glass	222-53135E
233,4 x 220	70	71	Epoxy glass	222-53136B

Note: Hole grid 2,54 x 2,54mm hole dia. 1,02mm

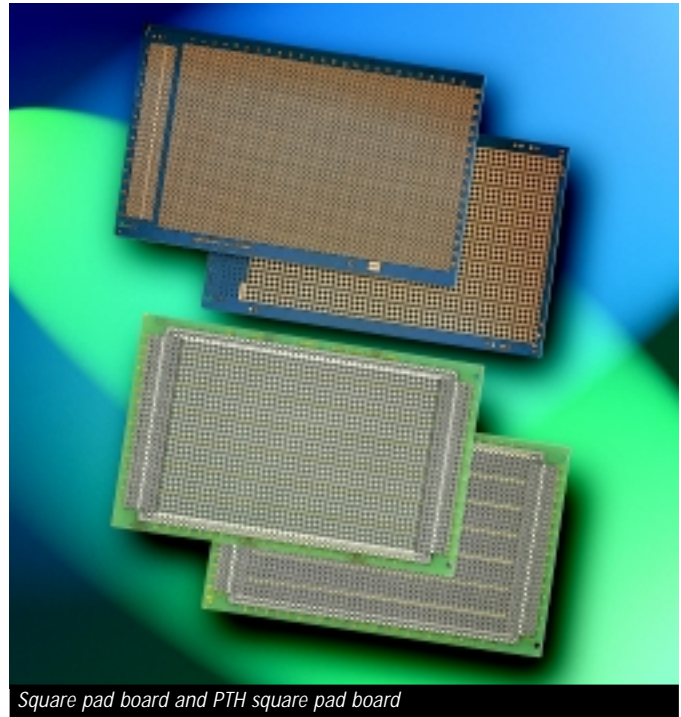

Square pad board and PTH square pad board

Prototyping boards

BUDGET EUROCARD

A range of low cost prototyping boards primarily for hard wiring of general discrete components, as used in analogue and general circuitry, but equally useful where a number of common bus or signal lines are required.

Features

- Ideal for low cost prototyping
- DIN 41494 (KM6-11) compatible
- Fixing holes provided for DIN 41612 connector
- Microbus backplane compatible

Board specification

Board type	SRBP
Double sided copper	BS 4584 part 5
Max. working temp.	97°C
Nom. board thickness (inc. copper)	1,6mm
Copper thickness	35µm or 1oz/ft ² or 305g/m ²

Ordering information

Description: Budget Eurocard

Board dims.	No. of tracks	Hole per track	Order code
100 x 160	36	60	09-2196L
100 x 220	36	83	09-27562G

Note: hole grid 2,54 x 2,54mm Hole dia. 1,02mm

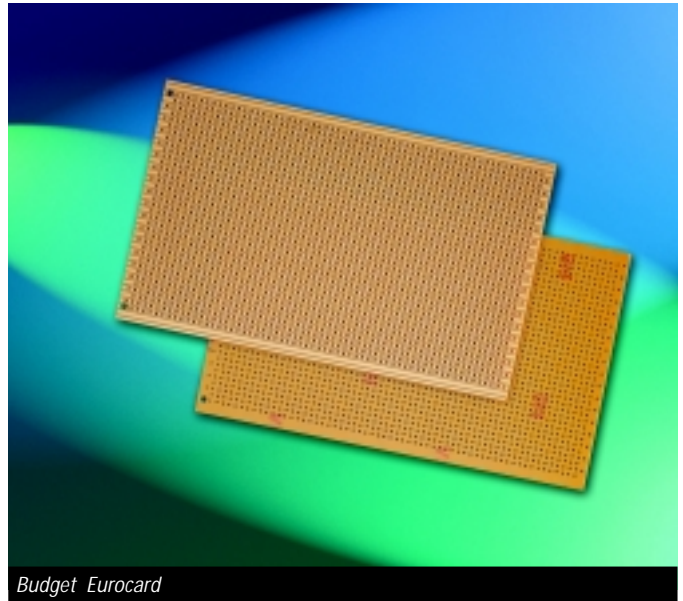

Budget Eurocard

DIP BOARD

A low density board designed for hard wiring of integrated circuits. Ample room is provided between rows for wiring looms and discrete components. 0V and Vcc rail patterns duplicated on component side of board give increased power distribution.

Features

- Ideal for hard wiring applications
- DIN 41612 or DIN 41617 connector patterns
- Grid print to aid component layout
- Microbus backplane compatible

Note: The board pattern is turned through 90° on double Eurocard versions in order to maximise packaging density.

Board specifications

Board type	Epoxy glass	SRBP
Double sided copper	BS4584 part 16	BS4584 part 5
Max. working temp.	155°C	97°C
Nom. board thickness (inc copper)	1,6mm	
Copper thickness	35µm or 1oz/ft ² or 305g/m ²	

Ordering information

Description: DIP Board

Board Dimensions	7,62 pitch	15,24 pitch	Base material	Order code
	IC DIP rows/pads	IC DIP rows/pads		
100 x 160	4/32	3/32	SRBP	10-1041J
100 x 160	4/32	3/32	Epoxy	10-1042D
233,4 x 160	7/47	6/47	Epoxy	10-3183G

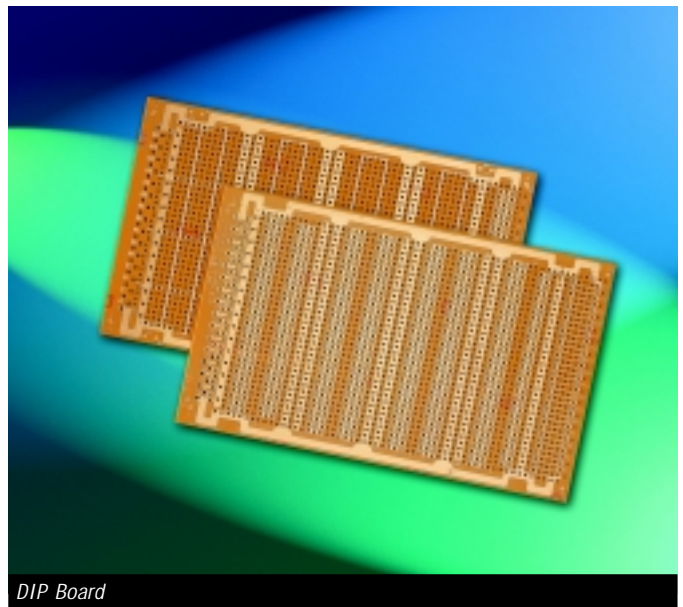

DIP Board

Prototyping boards

PLUG-IN VEROBOARD

This board combines the unique Veroboard pattern with the 37 way 2,54mm pitch direct edge connector. Intended primarily for hard wiring of discrete components it is equally useful where a number of common bus or signal lines are required.

Features

- Ideal for hard wired applications
- 37 way 2,54mm pitch gold plated tongue

Board specification

Board type	Epoxy glass
Base material	SRBP
Single sided copper	BS4584 part 16
Max. working temp.	155°C
Nom. board thickness (inc. copper)	1,6mm
Copper thickness	35µm or 1oz/ft ² or 305g/m ²

Ordering information

Description: plug-in Veroboard

Dimensions	Tracks	Holes per track	Base material	Order code
100 x 160	37	57	SRBP	09-1036G

Note: hole grid 2,54 x 2,54mm Hole dia. 1,02mm Contact pitch 2,54mm

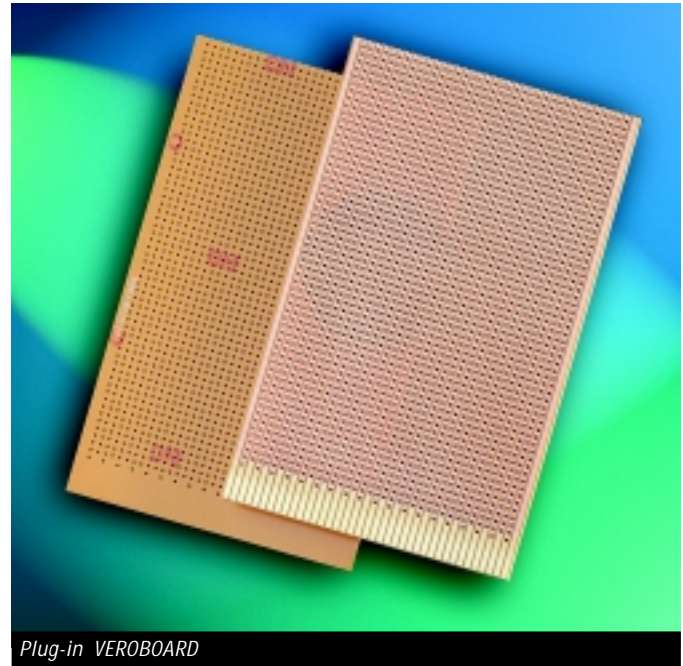

Prototyping boards

VEROBOARD METRIC PITCH

A range of general purpose Eurocards primarily for hard wiring of discrete components, typically in analogue circuits, they are equally useful where a number of common bus or signal lines are required. The boards feature a metric pitch of 2,50 x 2,50mm or 5,0 x 2,50mm which is not DIN 41612 compatible, but can be used inside modules.

Features

- Metric pitch
- Ideal for hard wiring of discrete components

Ordering information

Description: Veroboard, metric pitch

Board dimensions	Tracks	Holes/ track	Board pitch	Base material	Order code
100 x 160	39	64	2,5 x 2,5	SRBP	09-1034F
100 x 160	39	64	2,5 x 2,5	Epoxy	09-1461H

Note: hole dia. 1,02mm

PLAIN BOARDS, METRIC AND IMPERIAL PITCH

These boards offer total flexibility for the hard wiring of discrete components or the mounting of wirewrap sockets and pins and for the prototyping of analogue circuitry.

Features: Metric pitch

- Ideal for hard wiring of discrete components
- For use with solder pins
- Total flexibility
- Compatible with KM6 cardframes

Features: Imperial pitch

- Compatible with KM6 cardframes
- Fibreglass material
- For use with solder pins or wirewrap DIP sockets
- DIN 41612 connector compatible
- Grid printed for component reference

Ordering information

Description: Plain boards - metric and imperial pitch

Board dimensions	Rows of holes	Hole matrix	Base material	Order code
100 x 160	34 x 64	2,5 x 2,5	SRBP	09-1040J
100 x 160	39 x 60	2,54 x 2,54	Epoxy	09-19082K

Note: hole dia. 1,02mm

Boards specifications

Board type	Epoxy glass	SRBP
Single sided copper	BS4584 part 16	BS4584 par t5
Max. working temp.	155°C	97°C
Nom. board thickness (inc. copper)	1,6mm	
Copper thickness	35µm or 1oz/ft ² or 305g/m ²	

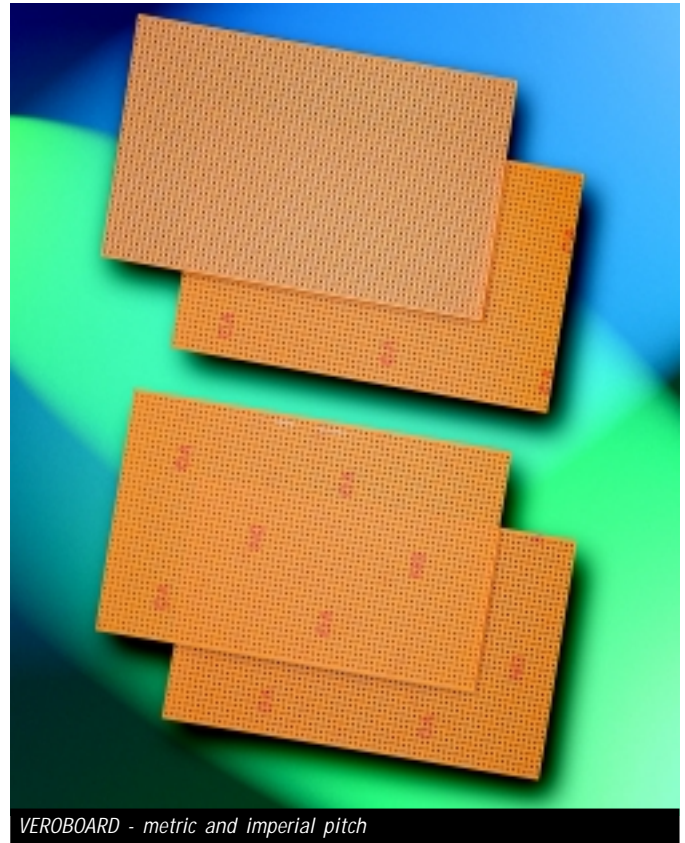

VEROBOARD - metric and imperial pitch

Non-Eurocard Prototyping Boards

VEROBOARD - SINGLE SIDED COPPER

Ideal for development and prototyping work, Veroboard is designed primarily for hard wiring of discrete components, typically in analogue circuits, but is equally useful where a number of common bus or signal lines are required.

Veroboard is manufactured from copper clad laminated board which has been pierced with a grid of holes and machined to provide parallel tracks.

Features

- Ideal for hard wiring or discrete components
- Range of standard sizes
- Choice of hole sizes and grid pitch

Ordering information

Description: Veroboard, single sided copper

Board dimensions	No. of pierced copper tracks	Holes/ track	Base material	Order code
121,92 x 101,60	41	44	SRBP	01-0021H
100,84 x 162,56	28	64	SRBP	07-0008H
111,76 x 176,53	40	61	SRBP	01-0014K
204,75 x 393,70	78	155	SRBP	67-1902F
95,10 x 454,66	34	179	Epoxy	01-0112B
95,10 x 454,66	34	179	SRBP	01-0040A
119,38 x 454,66	36	179	SRBP	01-0041G
119,38 x 454,66	38	179	SRBP	01-0043H
179,07 x 454,66	60	179	SRBP	01-0042B
100,00 x 500,00	36	197	SRBP	01-27567D
100,00 x 500,00	36	197	Epoxy	01-27568L

Note: hole grid 2,54 x 2,54mm Hole dia. 1,02mm

VEROSTRIP - SINGLE SIDED COPPER

A variant of Veroboard designed to provide a simple and inexpensive mounting board for discrete components or integrated circuits. The board is suitable for all applications where a conventional tag strip or group board might be used.

Features

- Ideal for hard wiring of discrete components
- Central track break already provided

Ordering information

Description: Verostrip, single sided copper

Board dimensions	No. of pierced copper tracks	Holes/ track	Base material	Order code
38,1 x 214,6	81	15	SRBP	01-0171D

Note: Hole grid 2,54 x 2,54mm Hole dia. 1,02mm

Board specifications

Board type	Epoxy glass	SRBP
Single sided copper	BS4584 part 16	BS4584 part 5
Max. working temp.	155°C	97°C
Nom. board thickness (inc copper)	1,6mm	
Copper thickness	35µm or 1oz/ft ² or 305g/m ²	

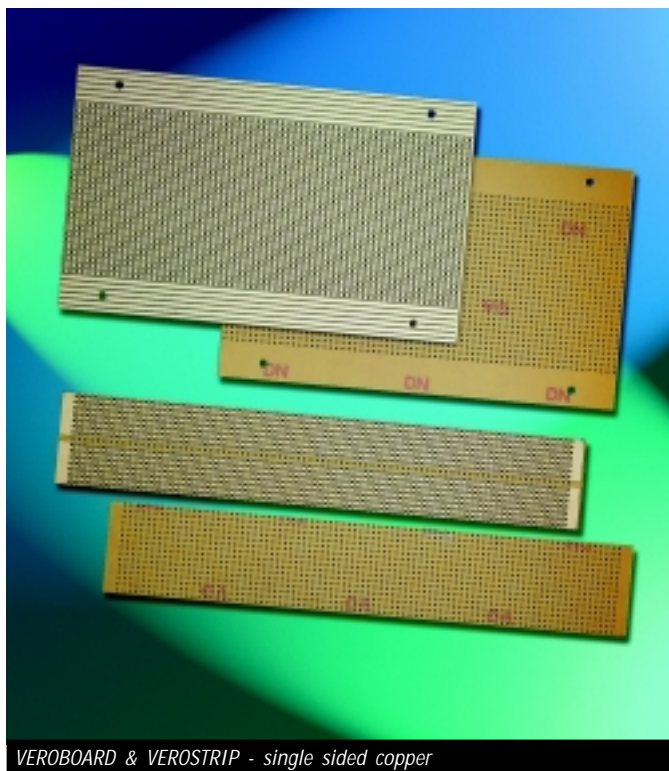

VEROBOARD & VEROSTRIP - single sided copper

Non-Eurocard Prototyping Boards

PLAIN BOARD

A fully pierced board designed for prototyping analogue circuitry. Utilising APW terminal pins, this board offers total flexibility for hard wiring of discrete components or wirewrapping sockets or pins.

Features

- Ideal for hard wiring of discrete components
- Total flexibility
- May also be used for wirewrapping

Board specifications

Board type	SRBP
Double/single sided copper	BS4584 part 5
Max. working temp.	97°C
Nom. board thickness (inc. copper)	1,6mm
Copper thickness	35µm or 1oz/ft ² or 305g/m ²

Ordering information

Description: Plain board

Board dimensions	No. of holes width	No. of holes Length	Base material	Order code
95,10 x 454,66	34	179	SRBP	02-0134D

Note: hole grid 2,54 x 2,54mm Hole dia. 1,02mm

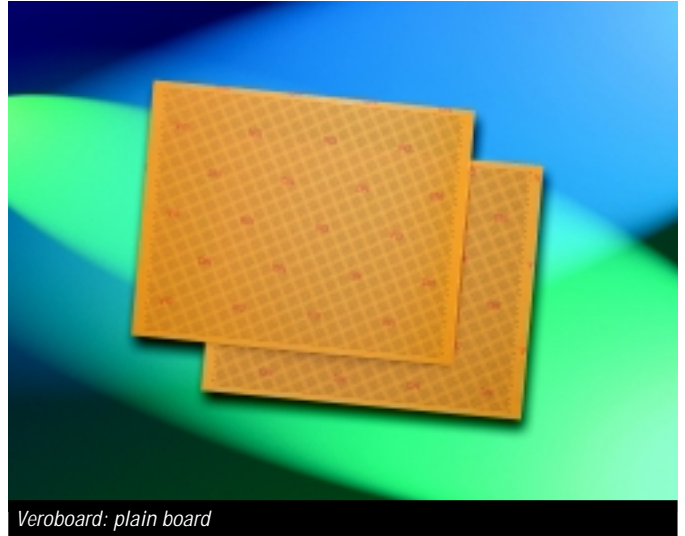

Veroboard: plain board

DIP BREADBOARD

A range of low density boards for hard wiring of integrated circuits, particularly useful in R & D applications. 0V and Vcc rail patterns are duplicated on the component side of the board giving increased power capacity. These boards do not have gold plated contacts, therefore offering a cost saving over plug-in boards. In place of contacts, individual mounting pads for terminal pins are provided.

Features

- Ideal for hard wired applications
- Grid print to aid component layout
- Full range of terminal pins available for interfacing

Ordering information

Description: DIP Breadboard

Board dimensions	Rows/ Pads	Rows/ Pads	Base material	Order code
114,30 x 156,21	4/39	4/39	SRBP	06-0166F
203,30 x 194,31	5/76	5/76	SRBP	06-0168G

Note: 7,62 pitch IC DIP 15,24 pitch IC DIP

Note: hole grid 2,54 x 2,54mm hole dia. 1,02mm

Board specifications

Board type	SRBP
Double/single sided copper	BS4584 part 5
Max. working temp.	97°C
Nom. board thickness (inc. copper)	1,6mm
Copper thickness	35µm or 1oz/ft ² or 305g/m ²

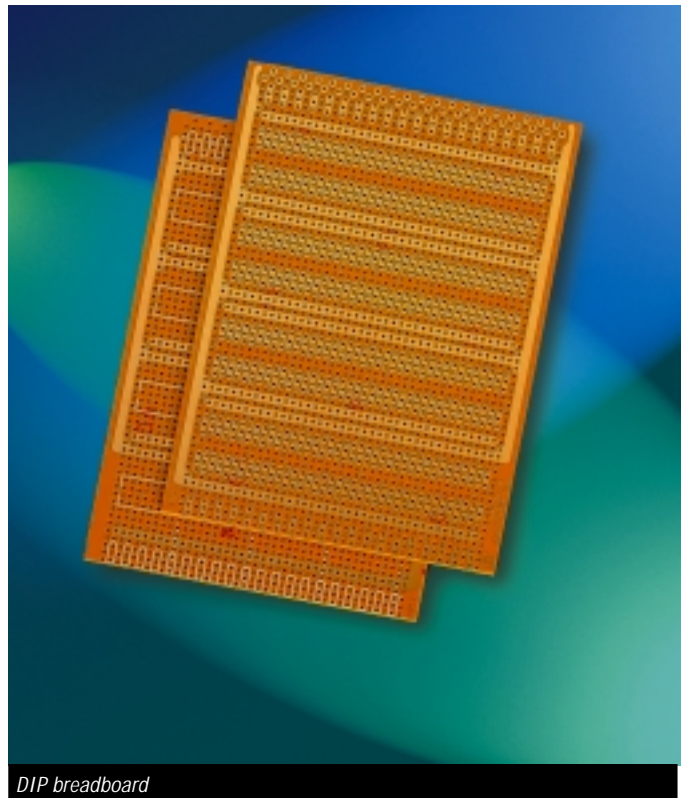

DIP breadboard

Non-Eurocard Prototyping Boards

DIP PLUG-IN BOARD: FOR SINGLE AND DOUBLE SIDED CONNECTORS

This range of DIP boards is provided with either single or double sided contacts for interfacing via direct, edge card connectors. Primarily low density, they have been designed for hard wiring of integrated circuits. A test point facility is given by copper pads situated at the front end of each board.

Features

- Ideal for hard wiring applications
- Single or double sided contacts
- Profiled or full width gold plated tongue
- Choice of contact pitch and number of ways
- Grid pattern to aid component layout
- Test point facility

Board specification

Board type	Epoxy glass
Double sided copper	BS4584 part 16
Max. working temp.	155°C
Nom. board thickness (inc. copper)	1,6mm
Copper thickness	35µm or 1oz/ft ² or 305g/m ²

Ordering information

Description: DIP Plug-in board for single and double sided connectors
7,62/15,24

Board dimensions	pitch ICs rows/pads	Tongue no.of ways	Base material	Order code
114,3 x 165,1	4/39	22/22	Epoxy	06-0147B

Note: Hole grid 2,54 x 2,54mm Hole dia. 1,02mm

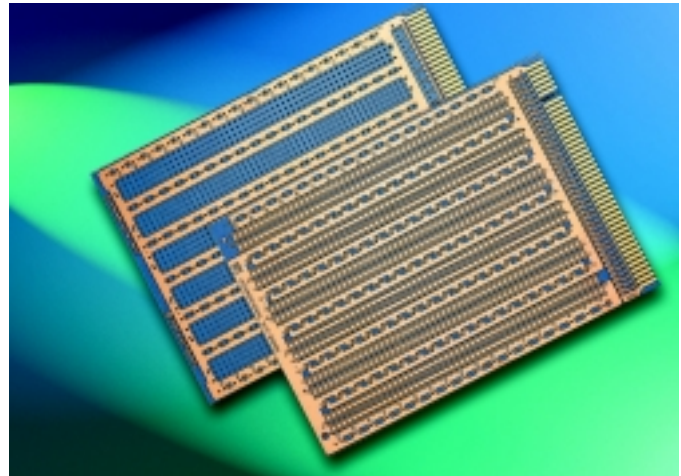

DIP plug-in board for single and double sided connectors

Eurocard extender boards

DOUBLE SIDED EXTENDER BOARDS

A range of double sided extender boards to enable testing of single and double height Eurocards, suitable for both 160 and 220mm deep frames, using DIN 41612 type B and C connectors. The extender board plugs directly into a subrack connector with the unique support/ejector mechanism at the front supporting the board under test.

Terminal assemblies (supplied with the boards), may be fitted to the board to allow easy attachment of scope probes typically for measuring voltage levels.

Note: This feature is not available on the 96/96 way extenders.

Features

- Eurocard compatible
- Suitable for 160 and 220mm deep boards
- DIN 41612 type B and C connectors
- Support/ejector mechanism
- Terminal assemblies for ease of testing (except 96/96 way versions)
- Solder resist coating to prevent solder bridging and prevent finger staining

Contents of kit

Item/description
Board (assembled with connectors)
2 Support/eject mechanisms
Terminal assemblies (where applicable)

Ordering information

Description: Double sided extender boards

For frame height	Connectors fitted		type	Order code
	plug	socket		
3U	1 off	1 off	64/64	09-3817H
6U	2 off	2 off	64/64	09-0106D
3U	1 off	1 off	64/96	09-3865K
6U	2 off	2 off	64/96	09-0108E
3U	1 off	1 off	96/96	09-2459K
6U	2 off	2 off	96/96	09-2460E

Note: hole grid 2,54 x 2,54mm hole dia. 0,9mm

Note: 3,81mm gap on double height boards

60mm DAUGHTER BOARD EXTENDER

A multilayer extender fitted with 96/96 way plug and 96/96 way socket suitable for adapting a 160mm deep daughter board to fit into a 220mm deep card slot or a 220 deep daughter board to fit into a 280mm deep card slot. The extender is 60mm deep so that front panels are positioned correctly.

Ordering information

Description: 60mm daughter board

Size	Order code
60 x 100	38-42640F

Board specification

Board type	Epoxy glass
Plated through hole	BS4584 part 16
Copper thickness to outer layers	38µm
Plated copper	37µm
Tin lead	5µm
Total	80µm
Copper thickness inner layers	38µm

Note: Bare boards are UL 94 V-0 recognised components file number E116551. Bare boards are approved to BS9762.

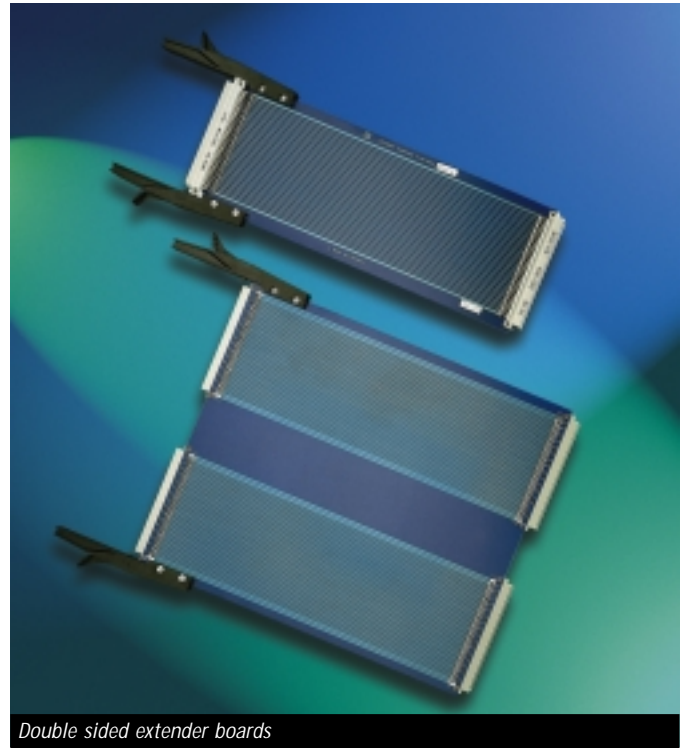

Double sided extender boards

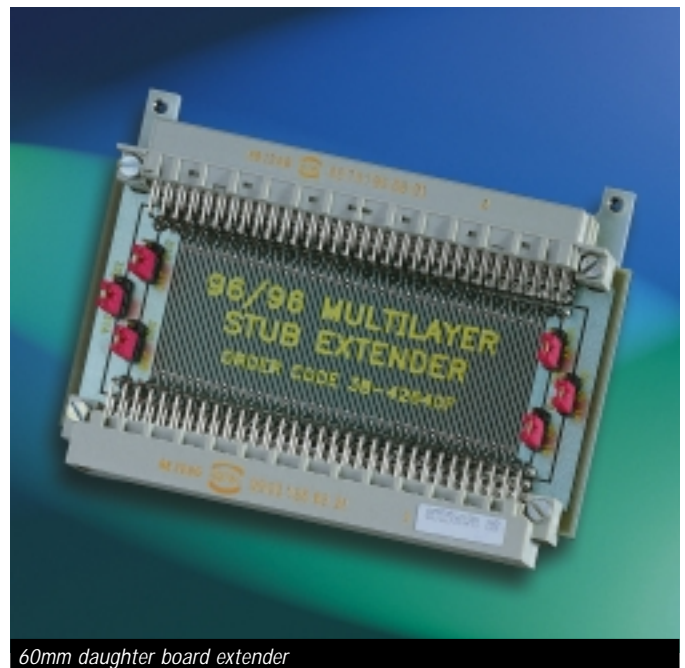

60mm daughter board extender

Eurocard extender boards

STANDARD AND SUPER PTH EXTENDER BOARDS

A range of PTH extender board assemblies available in two combinations of standard and super. The standard range, in either 64/64 or 96/96, is assembled with front and rear DIN connectors and supplied complete with ejector arms. The super version, in 96/96 format only, is supplied as per the standard format but also including gold plated wirewrapping pins, jumper links and logic analyser reverse DIN connector. The boards provide a high degree of mechanical flexibility and have many electrical advantages over their double sided predecessors.

Features

- Expandable height in multiples of 3U, i.e. 3U, 6U, 9U etc. is achieved by simply adding a standard divider plate assembly as required
- The ability to mix different types of extenders on 3U upwards to suit a particular bus system
- Suitable 160 and 220mm deep systems
- Maximum track widths with a copper plating thickness of 70µm in order to minimise voltage drop
- DIN connector outer rows 1abc, 2abc, 31abc and 32abc have extra wide tracks to match power rails on most standard bus systems, i.e. APW Microbus range
- Voltage and current measuring facilities available by either simply breaking tracks and pinning for the addition of jumper links (see illustration) or using the fully assembled super version (see illustration)
- Standard versions provide the facility for mounting a backplane stub terminator or logic analyser to the side of the board as required. This is supplied complete with the super version.
- Provides support/eject mechanism to ensure the daughter board remains captive within the guides when ejecting and that the correct connector breaks when dismantling
- Solder resist coated to prevent solder bridging of joints and finger staining

Ordering information

Description: PTH Extender boards	Order code
64/64 Standard PTH extender board	188-29937F
96/96 Standard PTH extender board	188-27573A
96/96 Super PTH extender board	188-39011D
Extender board conversion kit	188-27542E

Board specification

Board type	Epoxy glass
Plated through hole	BS4584, EP-GC-Cu FR4
Max. working temp.	155°C
Nom. board thickness	1,6mm
Laminated copper thickness	35µm or 1oz/ft ² or 305g/m ²
Plated copper	25µm
Tin lead	10µm
Total	70µm

Note: Bare boards are UL 94 V-0 recognised components file number E116551.
Bare boards are approved to BS9762

Accessories

Jumper links, wirewrapping pins, reverse DIN connector.

Ordering information

Description: Accessories	Order code
Jumper links Red/10	188-29988E
Jumper links Black/10	188-29989B
Wirewrapping pins/100	188-29990C

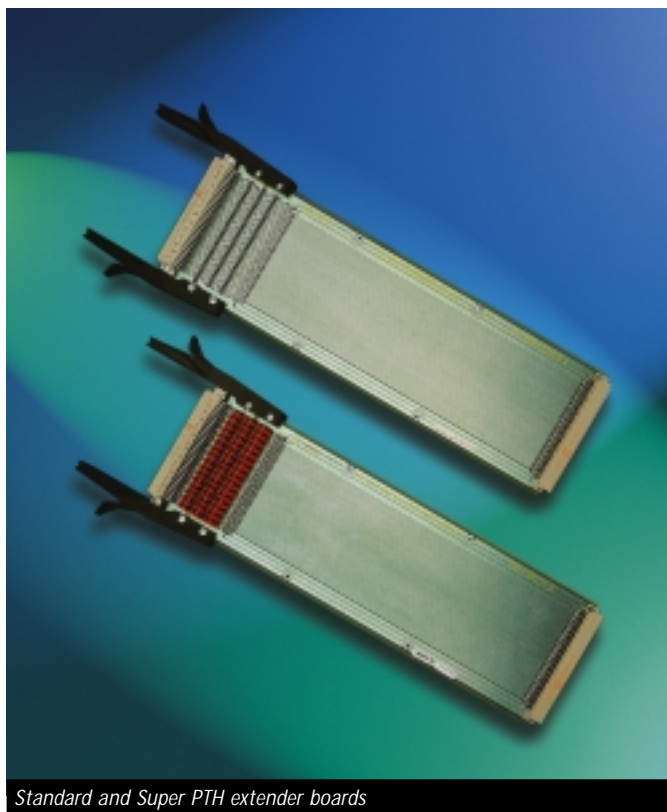

Standard and Super PTH extender boards

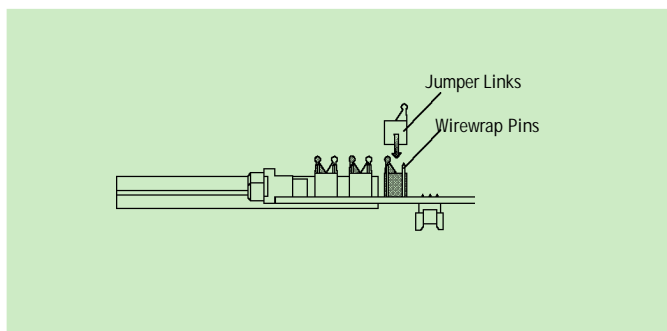

Eurocard extender boards

MULTILAYER EXTENDERS

This multilayer extender board offers the engineer the best possible guarantee against crosstalk due to the 0V guarding being positioned on three sides of each individual signal line.

The multilayer construction features a control 0V ground plane inner layer with a latticed trace around all jumper pin positions for maximum shielding. The extender board features 42 signal lines on both sides of the board which are protected by an 0V guard track between each pair of signal lines. The guard track is connected to the 0V inner layer plane at both ends by the use of via holes.

The power rails on the outer edges of the board feature a cross patching facility which uses jumper links in order to give the user complete flexibility when trying to match a particular backplane system. The board is supplied completely assembled with connectors at both ends.

Power rails are committed to pins 1abc, 2abc, 31abc and 32abc. If necessary any of these power rails may be connected to the 0V inner plane by use of cross patching jumper links.

Features

- 3 layer bonded multilayer construction with a 0V ground plane sandwich between layers
- Patented 0V guard tracking between all signal lines
- Flexible power rail construction with up to four separate Vcc rails and a 0V return plane
- Voltage and current measuring facilities are available by use of wirewrapping pins and jumper links which are fully assembled to the board
- Logic analyser or backplane stub terminator position on board
- Expandable to 3U, 6U, 9U etc. in many combinations using the compatible range of PTH and super PTH extender boards
- Suitable for 160 and 220mm deep systems
- Compatible with multilayer Microbus backplanes and PTH backplanes
- Support/eject mechanism to ensure that the daughter board remains captive within the guides when ejecting and that the correct connector breaks when dismantling

Ordering information

Description: Multilayer extender board	Order code
96/96 multilayer extender board	38-39084J
Extender board conversion kit	188-27542E

Board specification

Board type	Epoxy glass
Plated through hole	BS4584 part 16
Copper thickness to outer layers	38µm
Plated copper	37µm
Tin lead	5µm
Total	80µm
Copper thickness inner layers	38µm

Note: Bare boards are UL 94 V-0 recognised components file number E116551.
Bare boards are approved to BS9762.

Characteristics impedance

The separation of signal layers to the 0V ground plane is 0,74mm and the signal track width is 0,3mm which gives a theoretical characteristic impedance of 94Ω with a Z_0 tolerance of ±5%.

Note: $Z_0 = 94\Omega \pm 5\%$ excluding all holes in the boards
 $Z_0 =$ approximately 80Ω including connector and jumper pin holes
 $Z_0 =$ approximately 65Ω when active daughter board is in position.

Note: The guard tracking arrangement is manufactured under licence from University College, London.

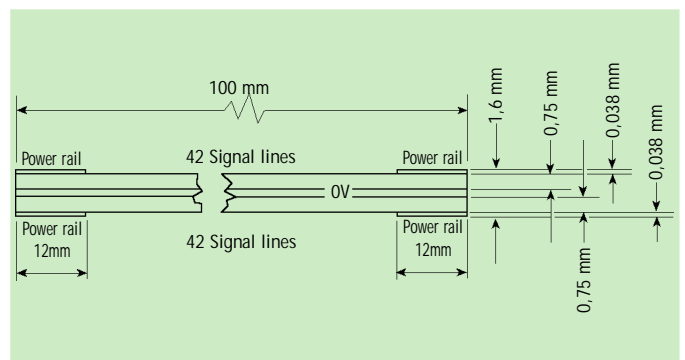
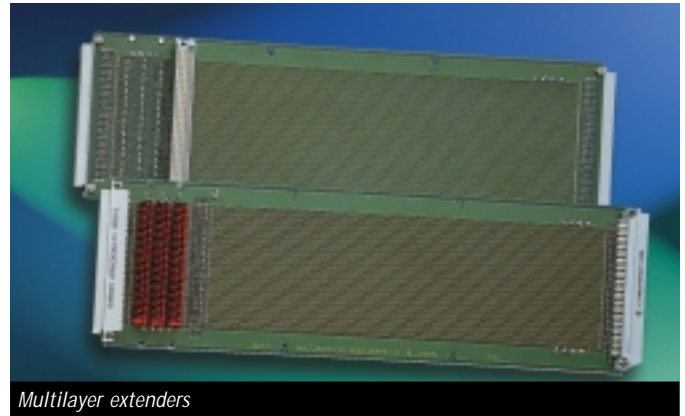

Eurocard extender boards

MULTILAYER UNCOMMITTED EXTENDER BOARDS

These extender boards have been designed to offer the greatest flexibility in the arrangement of power, ground and signal lines, yet afford the engineer the best possible protection against crosstalk by the use of a patented method of 0V guard tracking. The 96 signal lines are positioned over three layers with the facility to commit any line to any voltage. The remaining layers are committed to 0V and Vcc planes, thus minimising voltage drop over the length of the extender. These extenders are supplied completely assembled with connectors at each end plus wirewrap pins, jumpers and a reverse DIN connector for the fitment of a "stub" terminator or a logic analyser.

Signal lines can be committed to either 0V or Vcc by using the Commitment strap shown below. By fitting the tag into the holes in the guard track (round pads) adjacent, the connector pattern will commit the required pins to 0V. Conversely, rotating the strap 180° and fitting the tag to the square padded holes will commit to Vcc. This process is to be repeated at both ends of the extender.

Features

- 6 layer construction providing full voltage and ground planes
- Patented 0V guard tracking between all signal lines
- Full 0V and Vcc planes plus two auxiliary Vcc rails
- Suitable for 220 and 280mm deep subracks
- Total flexibility of voltage and ground committment
- Signal line interrupt facilities by means of wirewrap pins and jumper links which are pre-fitted to the board
- Reverse 96/96 DIN connector to accept stub terminator or logic analyser
- Support/eject mechanism to ensure that the correct connector breaks when dismantling and that the daughter board remains captive within the guides when ejecting
- Expandable in height by multiples of 3U. This is achieved by means of an extender board conversion kit

Board specification

Dielectric	Epoxy glass BS4584 EP-GC-Cu3 FR4
Nom. thickness	1,6mm
Base copper thickness	35µm
Finish	
Plated copper	25µm average
Tin lead	5µm nominal
Total	68µm outer layers only

Note: bare boards are UL 94 V-0 recognised components file number E116551. Bare boards are approved to BS9762.

The guard tracking arrangement is manufactured under licence from University College, London.

Ordering information

Description: Uncommitted extender boards

Size	Order code
220mm deep Un-committed extender	38-63623C
280mm deep Un-committed extender	38-61486J
Extender board conversion kit 220mm	188-27542E
Extender board conversion kit 280mm	188-39120J

COMMITMENT STRAP

These commitment straps drop over the tails of a DIN connector, committing a row of pins to a common voltage. The tag of the strap fits into the PTH hole which is assigned to the voltage or ground plane on the un-committed backplane or un-committed extender. The straps can be cut to size, ensuring only the required pins are committed. Commitment straps are supplied in packs of 100.

Ordering information

Description: Commitment straps	Order code
Pkt. 100	22-301331B



Multilayer uncommitted extender boards

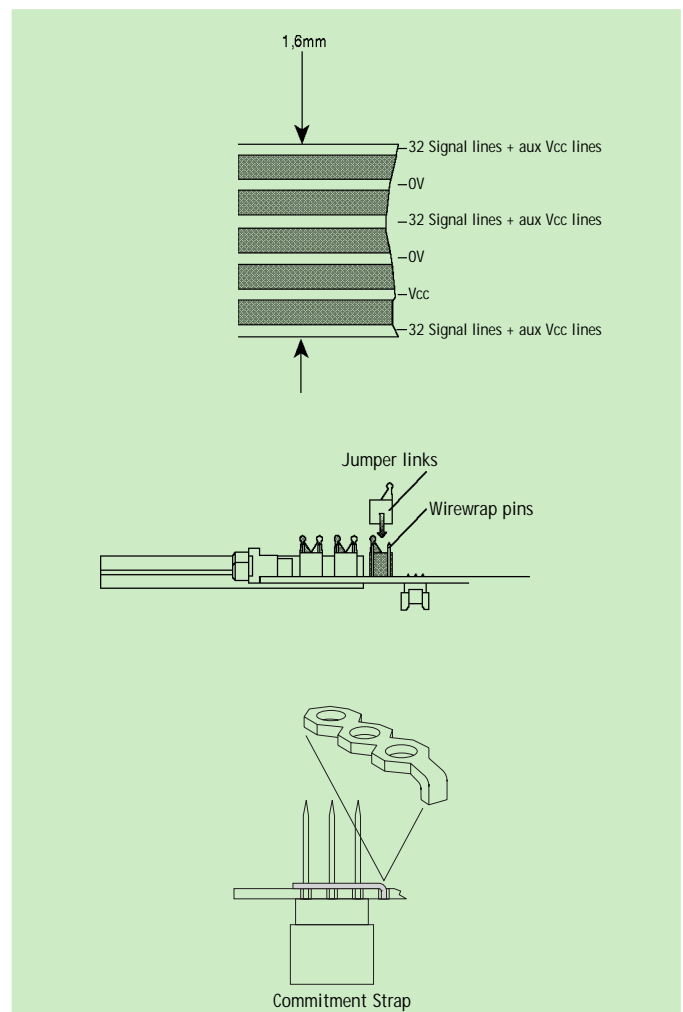

Eurocard development backplanes

MICROBUS BACKPLANES

Features

- PTH backplanes designed for use with microprocessors
- Reliability of plated through holes
- Minimal crosstalk
- DIN 41612 connectors
- DIN 41494 (KM6-II) compatible
- Choice of connector styles and pitches:
 - 15,24mm for PCB's for hard wired daughter boards
 - 20,32mm for two level wirewrap daughter boards

96/96 Version

Ideal for high speed applications using 96/96 way connectors, screening is provided on row b between each signal track on the backplane and, via the connector, through onto the individual cards. Alternatively, for slower applications the 96/96 way connector allows the use of a maximum of 84 separate signal lines by simply breaking the 0V commoning line in the end position. Using either of these methods input/output connections are generally made at the front end of the individual plug-in boards. If a 64/96 way connector is used on the system, the 0V screen is still a feature of the Microbus, with the added advantage of input/output connections being possible from the rear of the system.

When using 0V and two power rails, pin 1 and 32 on rows a, b and c are fully committed to 0V and commoned together at one end. Two separate Vcc planes are provided for dual voltage systems and are committed to pins 2 and 31 on rows a, b and c. If 0V and three power rails are required the same situation exists as for two power rails except that it is now necessary to convert 0V on pins 32 a, b and c to Vcc by simply cutting the 0V link on the extreme edge of the connector side of the backplane. Power onto the 0V and Vcc planes is made via plated through holes positioned beneath the connector fixing screws.

64/96 Way version

A low cost version of the Microbus backplane still with the reliability of plated through holes but restricted in use to only 64/96 way connectors. The basic design is very simple, with pin 1 and 32 on rows a and c committed to 0V with a complete 0V screen over one side of the board. Pin 2 and 31 on rows a and c are committed to Vcc. This leaves 56 separate signal lines from pin 3 a and c to pin 29 a and c inclusive.

Crosstalk

Tests have been carried out on the 84HP version by feeding a 1MHz square wave signal (5ns rise and fall times), through a DIN 41612 connector and measuring the adjacent tracks at the opposite end.

Note: The Microbus motherboard was not terminated, which would have reduced the amplitude to the crosstalk and changed its shape considerably.

Results: 96/96 way Microbus

Worst case in row c (square wave fed on row a) amplitude of crosstalk was 15% with only 8% on adjacent tracks in the same row.

Results: 64/96 way Microbus

Worst case in row c (square wave fed on row a) amplitude of crosstalk was 35% of main signal reducing further away from the main signal line. Adjacent tracks on the same row were 25-30% amplitude.

Ordering information

Description: Microbus backplanes

Conn. type	Conn. pitch (HP)	Size/Slots	Length	Order code
96/96	15,24 (3 HP)	84HP/28	426,3	222-2470F
96/96	20,32 (4 HP)	84HP/21	426,3	222-22847J
64/96	15,24 (3 HP)	84HP/28	426,3	222-26025F
64/96	20,32 (4 HP)	84HP/21	426,3	222-27569B

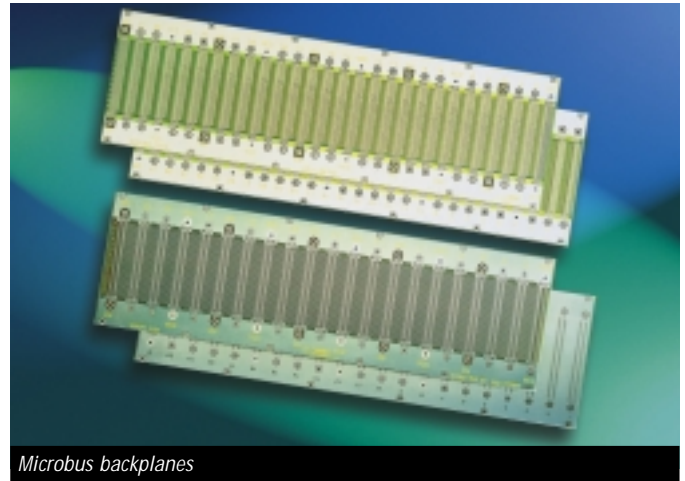

Microbus backplanes

Graph Test Data

- Temperature: 25°C
- Busbar width: 20mm
- Copper thickness width: 70µm
- Microbus typical impedance: 200Ω measured @1MHz
- DIN 41612 connector types B and C
- Power track resistance: less than 25mΩ/m, typically 19mΩ/m
- Signal track resistance: less than 1,2mΩ/m, typically 0,97mΩ/m
- Calculations based on both Vcc and 0V rails being used with single voltage

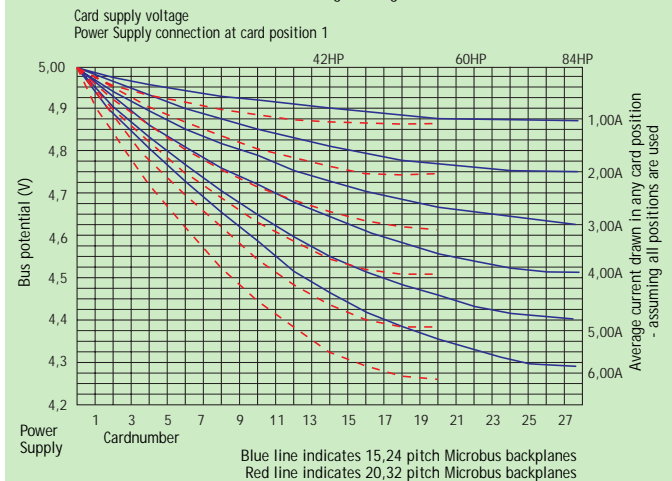

By connecting 0V and Vcc to the centre of the power rails rather than the end position as shown on the graph, the voltage drop will be halved. Similarly, if the intermediate positions are used, the voltage drop will be reduced proportionally.

Board specification

Dielectric	Epoxy glass	BS4584 , EP-GC-Cu3 FR4
Nominal thickness		1,6mm
Base copper thickness		35µm
Finish:	Plated copper	25µm average
	Tin lead	8µm maximum
	Total	68µm

Note: Bare boards are UL 94 V-0 recognised components file number E116551. Bare boards are approved to BS9762

Eurocard development backplanes

DOUBLE SIDED UNCOMMITTED BACKPLANE

This range of backplanes has been designed to be totally flexible, allowing the engineer to configure the backplane to exactly match the requirements of his system. Each pin is bussed across the board, with the added facility of using row b as 0V guard rails thus minimising crosstalk on rows a and c. Power connection to the backplane is by means of M3 studs or 6,3mm Faston tabs. To identify voltages a combination of studs and Fastons may be used. Power commitment to pins 1, 2, 31 and 32 is by a 2,54mm pitch link, other pins can be committed by either wirewrapping or hard wiring. Rows a, b and c can be linked together by the Commitment Strap.

Features

- Total flexibility on positioning of Vcc or 0V
- Four voltage rails available
- M3 stud or 6,3mm Faston power connection facilities
- Choice of backplane widths and pitches
- High quality PTH boards with resist coating to prevent solder bridging

Ordering information

Description: Uncommitted backplanes

Conn. type	Conn. pitch (HP)	Slots	Width x Length	Order code
96/96	20,32 (4 HP)	21	128,6 x 420,8	222-63630K
96/96	20,32 (4 HP)	10	128,6 x 197,3	222-63631G
96/96	20,32 (4 HP)	5	128,6 x 95,7	222-63632D
96/96	15,24 (3 HP)	28	128,6 x 425,9	222-63633A
96/96	15,24 (3 HP)	14	128,6 x 212,5	222-63634J

Board specification

Dielectric Epoxy glass	BS4584, EP-GC-Cu3 FR4
Nom. thickness	1,6mm
Base copper thickness	35µm
FinishPlated copper	25µm average
Tin lead	8µm nominal
Total	68µm

Note: Bare boards are UL 94 V-0 recognised components file number E 116551.
Bare boards are approved to BS9762.

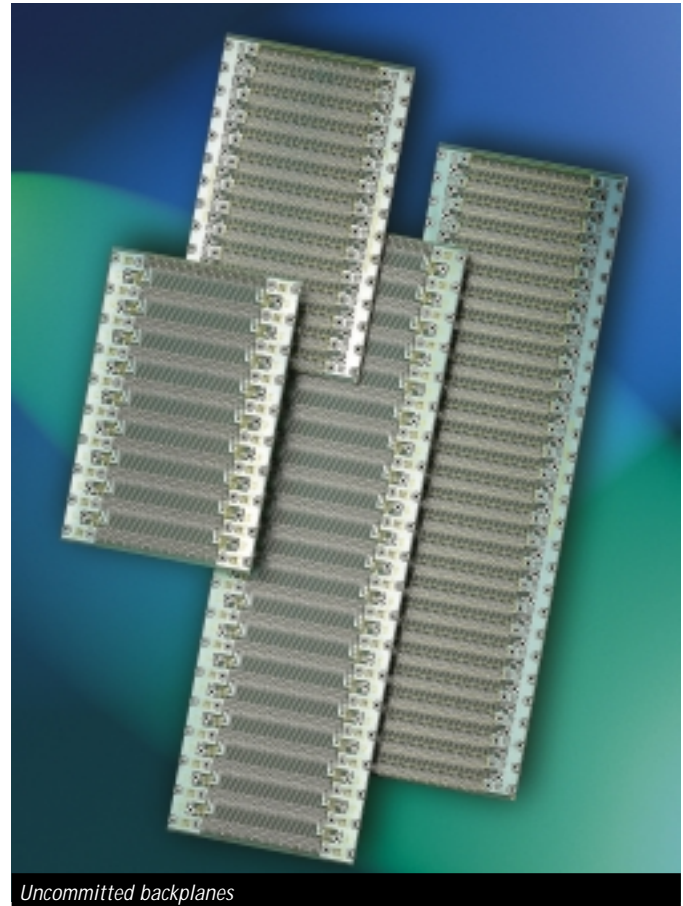

Uncommitted backplanes

COMMITMENT STRAP

These commitment straps drop over the tails of a DIN connector, committing a row of pins to a common voltage. The tag on the end of the strap fits into the PTH hole which is assigned to the voltage or ground plane on the un-committed backplane or un-committed extender. The straps can be cut to size, ensuring only the required pins are committed. Commitment straps are supplied in packs of 100.

Ordering information

Description: Commitment straps	Order code
Pkt. 100	22-301331B

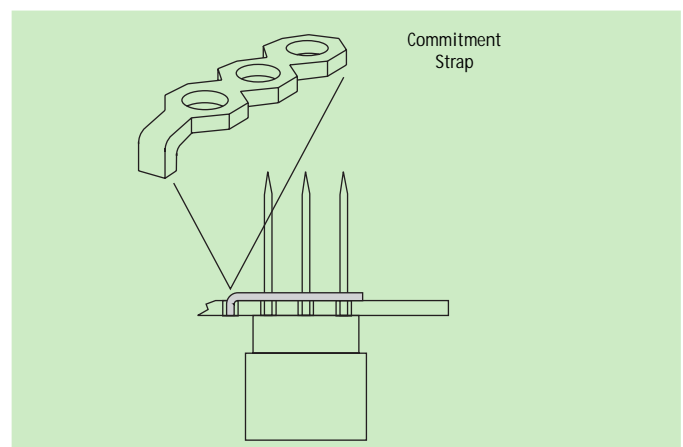

Eurocard development backplanes

MULTILAYER MICROBUS BACKPLANES

This range of multilayer Microbus backplanes is available in 0,8" (20,32mm) pitch and in widths of 5, 10 and 15 slots. All widths coincide with either 42HP, 60HP or 84HP KM6-II cardframes. All multilayer Microbus backplanes feature a patented tracking arrangement which includes 42 signal lines on each side of the board with a 0V guard track between each signal line. Power distribution is designed for use with a maximum of four power rails each capable of handling the total current rating of all connector pins, providing several feeders are used on order to distribute the load evenly.

Features

- 3 layer bonded multilayer construction with 0V ground plane sandwiched between signal layers
- Patented 0V guard tracking between all signal lines
- Theoretical characteristic impedance $Z_0 = 100\Omega \pm 5\%$
- Flexible power rail construction with up to four separate Vcc rails
- Fully assembled with 96/96 standard DIN 41612 compliant pin press-fit connectors and ample spade style power pick-up points
- 0,8 inch (20,32mm) pitch
- Compatible with KM6-II cardframes, multilayer extender boards and stub terminators

Ordering information

Description: Multilayer microbus backplanes

Slot pitch (HP)	No. of slots	Length x width	Cardframe width	Order code
20,32 (4 HP)	5	96 x 128	21HP	38-39104K
20,32 (4 HP)	10	212 x 128	42HP	38-39105F
20,32 (4 HP)	15	303 x 128	60HP	38-39106B

Board specification

Copper clad Epoxy glass board	BS4584
Nominal thickness	2,4mm
Copper thickness outer layers	38 μ m
Plated copper	37 μ m
Tin lead	5 μ m
Total	80 μ m
Copper thickness inner layers	38 μ m

Note: Bare boards are UL 94 V-0 recognised components file number E 116551.
Bare boards are approved to BS9762.

Characteristic impedance

The impedance of signal layers to the 0V ground plane is 1mm and the signal track width is 0,38mm which gives a theoretical impedance of 100 Ω with a Z_0 tolerance of $\pm 5\%$.

Note: $Z_0 = 100\Omega \pm 5\%$ theoretical impedance excluding holes in the board
 $Z_0 =$ approximately 80 Ω including connector holes in backplane
 $Z_0 =$ approximately 20 Ω fully loaded with boards

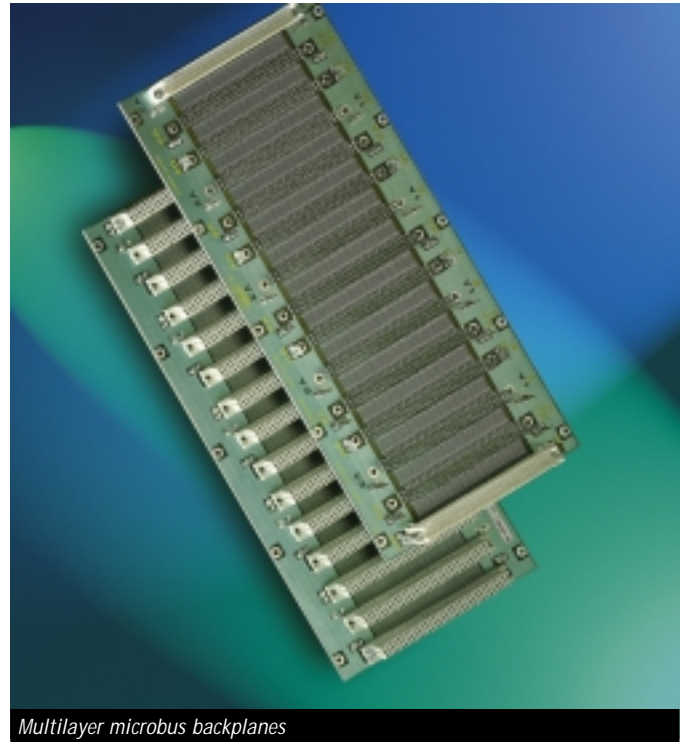

Multilayer microbus backplanes

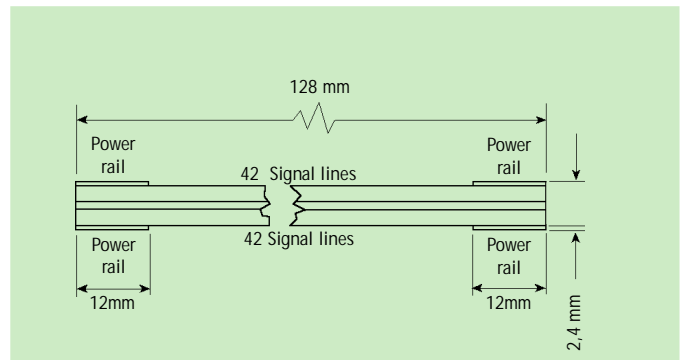

VEROWIRE and prototyping board accessories

VEROWIRE

The Verowire wiring system is ideal for prototypes, breadboards and limited production runs. Finished results are of a high standard with a neat orderly appearance achieved in significantly less time than more conventional methods.

Features

- n Low profile
- n High speed applications
- n Suitable for high-density wiring
- n No headers required
- n Low cost

Wire specification

Diameter of wire:	0,15 mm (34 AWG)
Insulation:	Self-fluxing polyurethane*
Insulation Thickness:	0,005 mm
Proof Voltage:	600V d.c.
Current Rating:	0,100 A
Resistance @ 20°C:	0,857 w/m
Length of wire/spool:	40 m
Colours:	Pink, Gold

***WARNING!** When soldering through polyurethane enamelled wire a small quantity of TDI gas is produced. Use in a well ventilated room.

Ordering information

Description	Unit of Sale	Order code
Wiring pen	1	79-1732G
Spools wire; 2 gold, 2 pink	4	79-19038G
Spool wire, Pink	4	79-1737D
Spool wire, Gold	4	79-1739E
Wiring combs	100	79-1735C
Half pin	1000	18-0223K

CARD SUPPORT - EJECTOR MECHANISM

Supplied as an accessory for any extender board, this device attaches to the plug end and guides/supports the circuit board under test. Supplied as a kit comprising 2 support-ejector assemblies, 4 M3 x 8 long screws and 4 M3 nuts.

Ordering information

Description	Order code
Card support/ejector	22-2427D

SPOT FACE CUTTER

Used to break copper tracks on a PCB. Can be used by hand or, with the handle removed, fitted into a bench drill.

Ordering information

Description	Order code
Spot face cutter	22-0239G

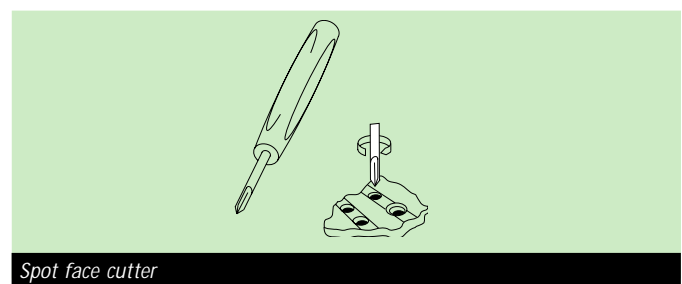
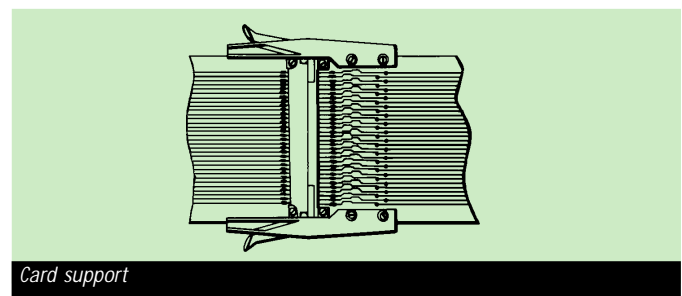
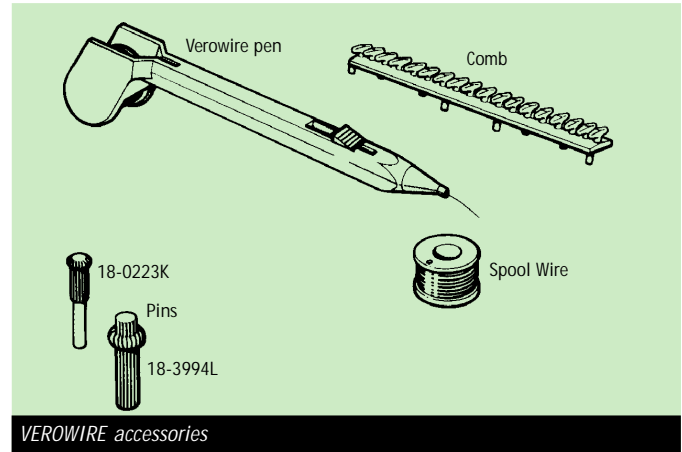

Prototyping board accessories

TERMINAL ASSEMBLY

This assembly is designed to act as a terminal on PC boards for attachment of scope probe etc. The spring design allows the terminal to be inserted into a plated through hole board without damaging the hole plating. The terminal will remain in place when the board is reversed for soldering. The sintered glass bead has a recommended maximum working temperature of 475°C. Assemblies are available for two different hole diameters. The terminal assemblies are available in five standard colours; black, yellow, red, white or green.

Note: Finish electroplated tin 5µm (nominal)

Nominal hole Ø	Dim. A (mm)	Dim. B (mm)	Dim. C (mm)
1,0 ±0,1 mm	1,1 - 1,3	3,1 - 3,3	2,3 - 2,5
1,4 ±0,2 mm	2,0 - 2,2	2,9 - 3,1	3,2 - 3,4

Ordering information

Bead	Nominal hole Ø	Nominal hole Ø
Colour	1,0mm ±0,1	1,4mm ±0,2
Red	20-313137D	20-313141G
Green	20-313138A	20-313142D
White	20-313139J	20-313143A
Yellow	20-313140K	20-313144J
Black	20-002137D	20-002136J

Supplied in packets of 100

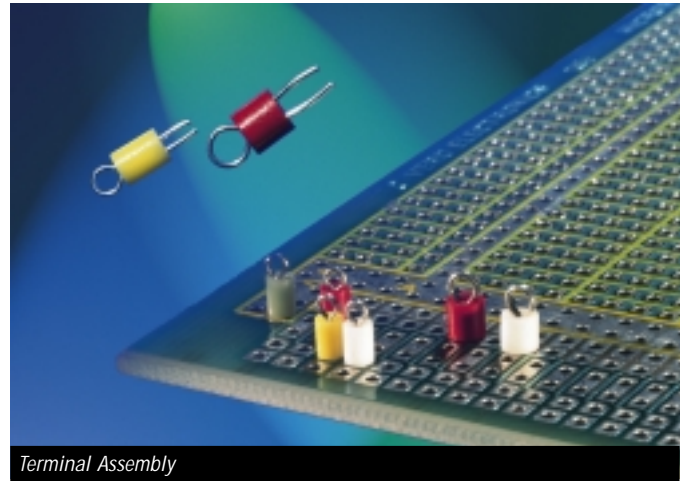

Terminal Assembly

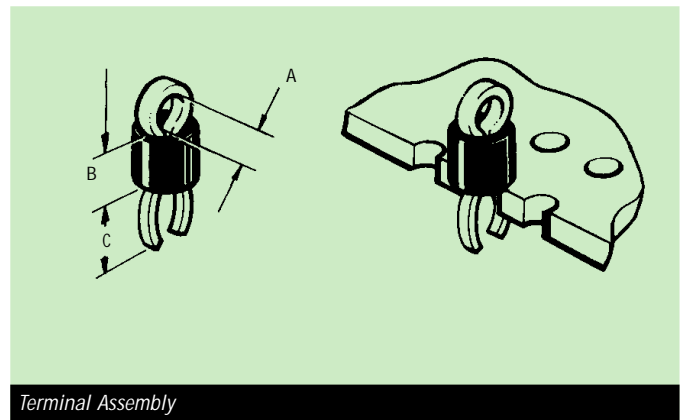

Terminal Assembly

Prototyping board accessories: Card handles

CARD HANDLE TYPE A

These card handles have provision for card identification, by means of a recess which may be covered by a clip-in window (supplied separately).

Ordering information

Colour	Material	Order code
Black	Noryl	21-0246C
Grey	Noryl	21-0247J
Red	Noryl	21-0248D
Blue	Noryl	21-0249K
Green	Noryl	21-0250E
Yellow	Noryl	21-0251L

Supplied in packets of 10

TYPE A ACCESSORIES

Ordering information

Item	Unit of Sale	Order code
Window & label	Kit	22-0318F

Kits include 10 windows and labels

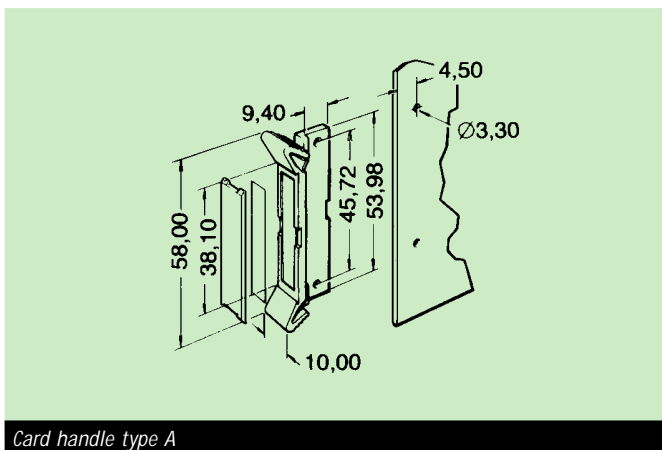

Card handle type A

CARD HANDLE TYPE B

Differs from type A only in the means of attachment to the board. This handle has a clip-on feature which enables it to be assembled onto a PCB 1,6 mm thick which is pre-drilled with 2,6 mm dia. holes.

Ordering information

Colour	Material	Order code
Black	Noryl	21-0252C
Grey	Noryl	21-0253A
Red	Noryl	21-0254G
Blue	Noryl	21-0255B
Green	Noryl	21-0256H
Yellow	Noryl	21-0257C

Supplied in packets of 10

TYPE B ACCESSORIES

Ordering information

Description	Order code
Window & label kit	22-0318F

Kits include 10 windows and labels

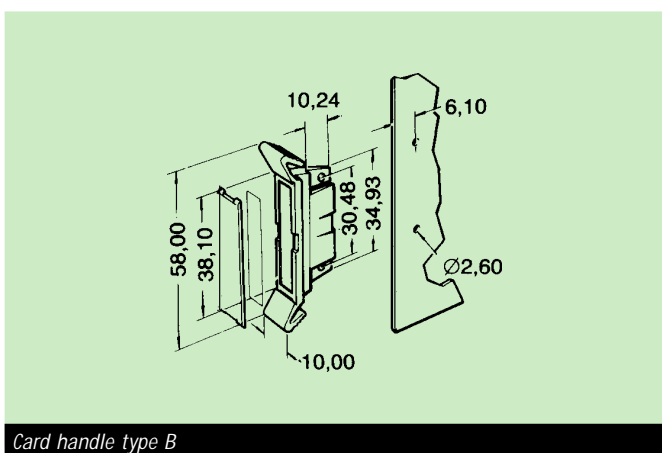

Card handle type B

Prototyping board accessories: Card handles

CARD HANDLE TYPE C

This handle has a clip-on feature, and is used for applications where a minimum of space is available on a PCB. Fixing hole dia. 2,6 mm.

Ordering information

Colour	Material	Order code
Black	Noryl	21-0240L
Grey	Noryl	21-0241F
Red	Noryl	21-0242A
Blue	Noryl	21-0243G
Green	Noryl	21-0244B
Yellow	Noryl	21-0245H

Supplied in packets on 10

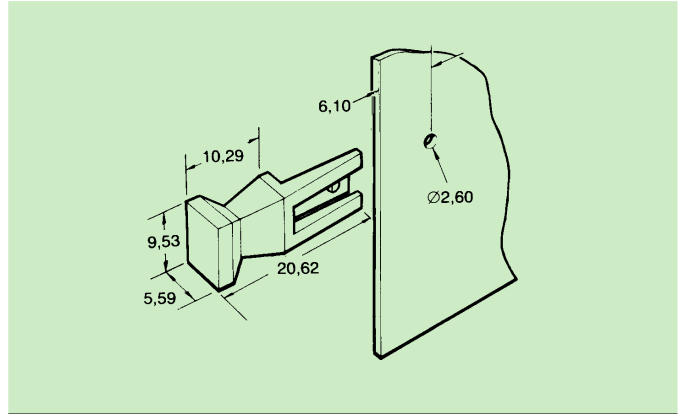

Card handle type C

CARD HANDLE TYPE D

These handles are made in a transparent makrolon material, so that the ident strip is readily visible from the front of the PCB. Supplied with 2 no. 4 self-tapping screws, this screw-on type handle also incorporates an identification strip.

Ordering information

Colour	Material	Order code
Clear	Makrolon	21-3170J
Amber	Makrolon	21-3171D
Red	Makrolon	21-3172K
Green	Makrolon	21-3173E
Blue	Makrolon	21-3174L

Supplied as a kit comprising 10 handles plus fixing

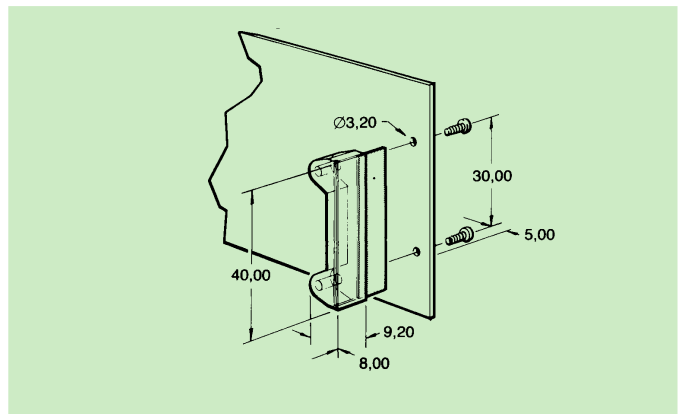

Card handle type D

CARD HANDLE TYPE E (FLEXIBLE HANDLE)

By bowing out from the board, when pulled, this handle enables a positive grip for card extraction. When not in use handle projects forward from the board edge less than 2,5 mm, making these handles fully compatible with the requirements of DIN 41494 (KM6-II).

The front surface of the handle is flat and provides ample space for card identification.

Ordering information

Colour	Material	Order code
Natural	Nylon 66	21-1884E
Red	Nylon 66	21-1885L
Green	Nylon 66	21-1886F
Yellow	Nylon 66	21-1887A
Black	Nylon 66	21-1888G
Blue	Nylon 66	21-1889B

Supplied as a kit of 10 handles and 20 fixing pins

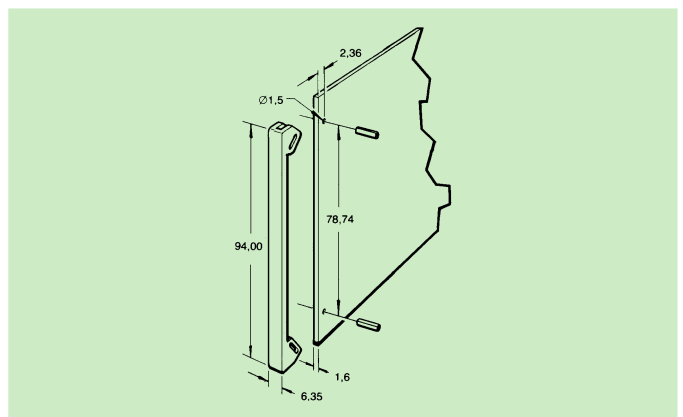

Card handle type E flexible handle

Prototyping board accessories: Headers and socket pins

MINIWRAP SOCKET PINS (TYPES 3, 4 & 5)

These pins have 4-leaf spring beryllium copper inserts enabling components to be plugged directly into sockets.

Type 3 is a low-profile pin allowing components to be mounted close to the board surface

Type 4 has a higher profile allowing heat to be dissipated by convection between the components and the board

Material: All wire wrapping pins are manufactured from brass to BS249 and gold plated over a copper and nickel finish (unless otherwise stated)

Post size: 0,61 mm square, 0,86 mm diagonal.

Socket pins - typical test data

(test data shown applies to 66-3472C and 66-3505A only)

Test	Result
Terminal retention	5,4 kgf
Contact resistance	Initial 5,3 mΩ average After 1000 insertions /withdrawals 6,4 mΩ av.
Low voltage	0,1 mA measured with open-circuit voltage of 10 μV
Salt spray (48 Hours)	Contact resistance <15 mΩ No evidence of galvanic corrosion
Humidity	No evidence of damage
Exposure to atmospheric pollution	5mΩ maximum

Ordering information

Type	Compatible hole dia.		Order code
	pierced	drilled	
3	-	1,45	66-3472C
4	1,02	1,05	66-3505A

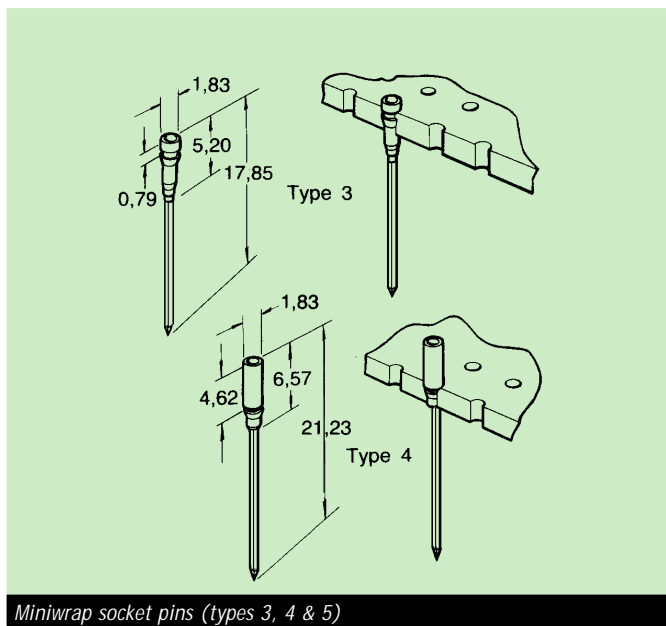

Miniwrap socket pins (types 3, 4 & 5)

MINIWRAP HEADED PINS (TYPES 1 & 2)

For mounting discrete components.

These pins feature a 0,89 mm cross-cut slot on the component side to locate component leads for assembly.

Ordering information

Type	Compatible hole dia.		Order code
	pierced	drilled	
1	1,32	1,40	66-3478F
2	1,02	1,05	66-3523K

Supplied in packets of 100

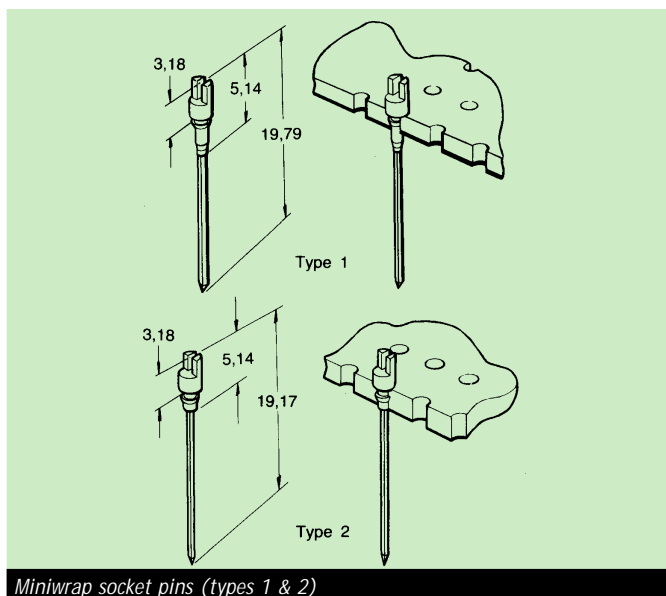

Miniwrap socket pins (types 1 & 2)

Prototyping board accessories: Headers and socket pins

TERMINAL HEADER PIN (TYPE 7)

May be mounted directly into header board or alternatively plugged into socket pins (66-3472C - type 3) or (66-3505A - type 4).

Ordering information

Type	Compatible hole dia.		Order code
	pierced	drilled	
7	1,32	1,40	66-3469G

Supplied in packets of 100

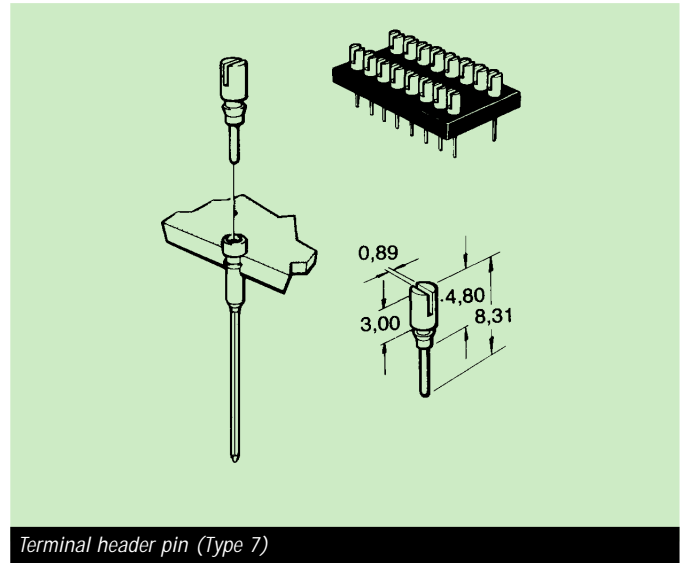

Terminal header pin (Type 7)

MINIWRAP TERMINALS (TYPE 9)

Suitable for use with all types of boards. This pin may be soldered to a copper track or pad to ensure electrical continuity.

Ordering information

Type	Compatible hole dia.		Order code
	pierced	drilled	
9	1,02	1,05	66-3514L

Supplied in packets of 100

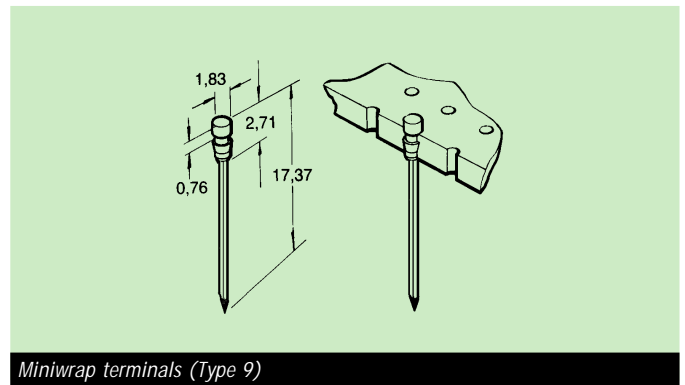

Miniwrap terminals (Type 9)

TEST POINT PINS (TYPE 12)

These pins feature a turreted lug on the component side, guaranteeing a firm connection using a clip-on style test probe.

Ordering information

Type	Compatible hole dia.		Order code
	pierced	drilled	
12	1,32	1,40	66-3532J

Supplied in packets of 100

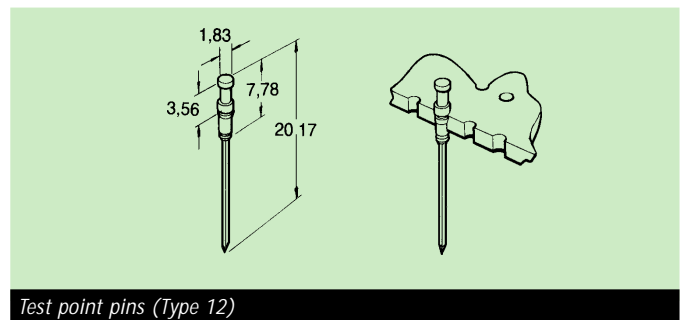

Test point pins (Type 12)

Prototyping board accessories: Wirewrapping pins

SINGLE SIDED PIN (TYPE 10)

For use with plain or copper-clad boards. These pins have the facility for soldering discrete components on one side and wire wrapping on the other.

Material: Manufactured from phosphor bronze to BS 2870 PB 102 with tin finish over copper flash.

Post size: 0,68 mm x 0,64 mm, diagonal 0,94 mm

Ordering information

Type	Compatible hole dia.		Order code
	pierced	drilled	
10	1,00	1,05	18-0226F

Supplied in packets of 500

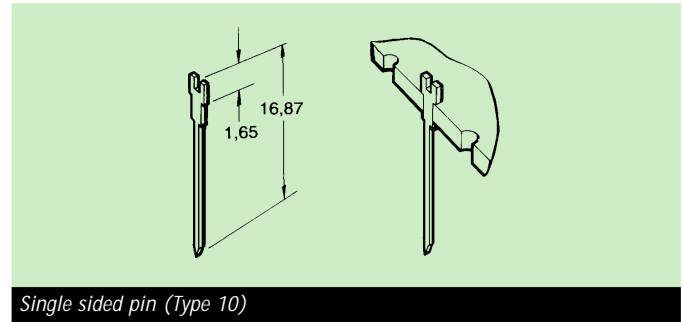

Single sided pin (Type 10)

DOUBLE SIDED PIN (TYPE 11)

For use when wire wrapping is required both sides of board.

Ordering information

Type	Compatible hole dia.		Order code
	pierced	drilled	
11	1,00	1,05	18-1657B

Supplied in packets of 500

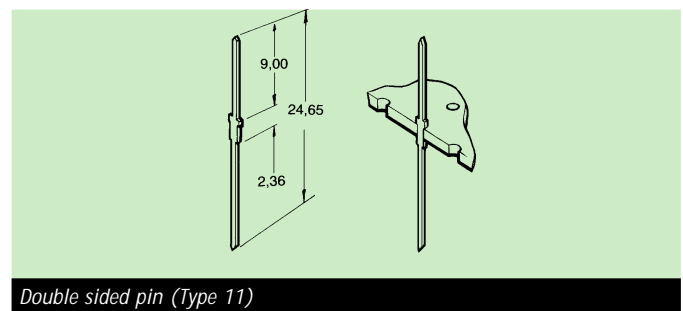

Double sided pin (Type 11)

Prototyping board accessories: Terminal pins

SOLDER TERMINAL PIN (TYPE 2)

By inserting pin up to its shoulder these pins stand at a fixed height above the board surface. The separated profile offers good mechanical retention while electrical contact is made by soldering shoulder to copper track. Available in two sizes for hole size 1,02 and 1,32 mm.

Ordering information

Hole dia.	Dimensions					Order code
	A	B	C	D	E	
1,00	9,7	5,6	1,1	1,0	0,4	18-0222D
1,32	11,9	6,7	1,4	1,2	0,5	18-0219H

Supplied in packets of 1000

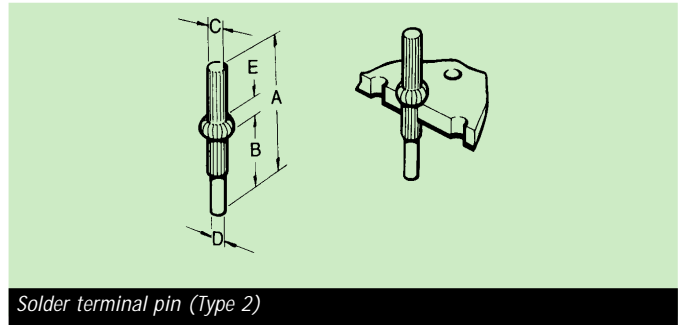

SOLDER TERMINAL PIN (TYPE 3)

Similar to 18-0222D but manufactured from phosphor bronze to BS 2873 PB 102, tin finish over copper flash.

Ordering information

Type	Qty	Hole dia.	Order code
3	1000	1,00	18-0218B

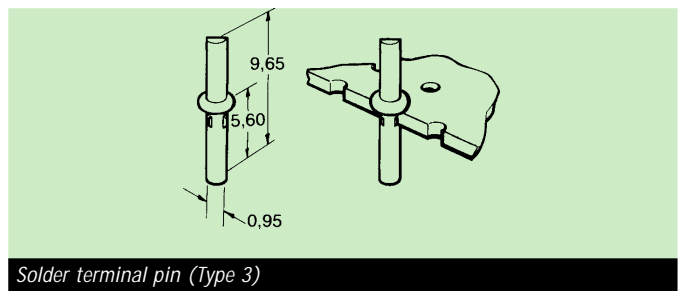

SOLDER TERMINAL HALF PIN (TYPE 4)

These pins are ideally suited to take off points or flying leads from a PCB. The shoulder is soldered to the copper track with the pin protruding on the component side of the board. Two sizes are available for 1,02 and 1,32 mm diameter holes.

Ordering information

Type	Qty	Hole dia.	Dim.A	Order code
4	1000	1,32	1,21	18-0217G
4	1000	1,00	0,93	18-0223K

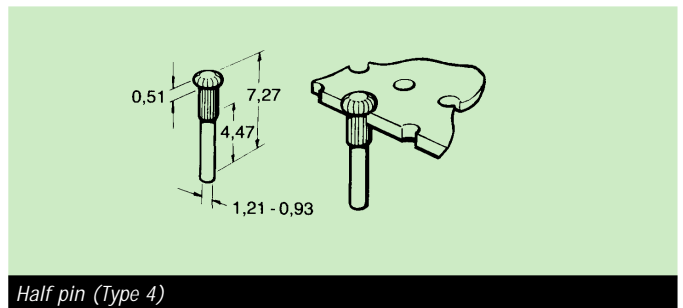

Order Code Index

Order Code	Page	Order Code	Page	Order Code	Page
	01	18-0223K	23		66
		18-0226F	29	66-3469G	28
01-0014K	13	18-1657B	29	66-3472C	27
01-0021H	13			66-3505A	27
01-0040A	13	20		66-3523K	27
01-0041G	13	20-002136J	24	66-3514L	28
01-0042B	13	20-002137D	24	66-3532J	28
01-0043H	13	20-313137D	24		67
01-0112B	13	20-313138A	24		
01-0134D	14	20-313139J	24	67-1902F	13
01-27567D	13	20-313140K	24		79
01-27568L	13	20-313141G	24		
	03	20-313142D	24	79-1732G	23
		20-313143A	24	79-1735C	23
03-0026J	8	20-313144J	24	79-1737D	23
03-0111L	8			79-1739E	23
03-2989L	9	21		79-19038G	23
03-2990F	8	21-0240L	26		188
03-27555K	8	21-0241F	26	188-27542E	17
03-27556F	8	21-0242A	26	188-27542E	18
03-27557B	8	21-0243G	26	188-27542E	19
	06	21-0244B	26	188-27573A	17
		21-0245H	26	188-29937F	17
06-0147B	15	21-0246C	25	188-29988E	17
06-0166F	14	21-0247J	25	188-29989B	17
06-0168G	14	21-0248D	25	188-29990C	17
	07	21-0249K	25	188-39011D	17
		21-0250E	25	188-39120J	19
		21-0251L	25		
07-0008H	13	21-0252C	25		222
	09	21-0253A	25	222-2470F	20
		21-0254G	25	222-2991F	4
		21-0255B	25	222-2992B	4
09-0106D	16	21-0256H	25	222-2993J	4
09-0108E	16	21-0257C	25	222-2994E	4
09-1034F	12	21-1884E	26	222-22847J	20
09-1036G	11	21-1885L	26	222-26025F	20
09-1040J	12	21-1886F	26	222-26492L	9
09-1461H	12	21-1887A	26	222-27561D	4
09-2196L	10	21-1888G	26	222-27569B	20
09-2459K	16	21-1889B	26	222-53134H	9
09-2460E	16	21-3170J	26	222-53135E	9
09-3817H	16	21-3171D	26	222-53136B	9
09-3865E	16	21-3172K	26	222-63630K	21
09-19082K	12	21-3173E	26	222-63631G	21
09-27562G	10	21-3174L	26	222-63632D	21
	10			222-63633A	21
		22		222-63634J	21
10-0581B	6	22-2427D	23		
10-1041J	10	22-0239G	23		
10-1042D	10	22-0318F	25		
10-2446C	7	22-301331B	19		
10-2449K	7				
10-2845B	5	38			
10-2858C	5	38-39084J	18		
10-3183G	10	38-39104K	22		
10-27558D	7	38-39105F	22		
10-27563H	5	38-39106B	22		
	18	38-42640F	16		
		38-63623C	19		
18-0217G	30	38-61486J	19		
18-0219H	30				
18-0218B	30				
18-0222D	30				
18-0223K	30				



www.apw.com

APW

Electron Way, Chandlers Ford,
Hampshire SO53 4ZR
England
44.23.8026.6300 telephone
44.23.8026.5126 fax
email: sales.backplanes@apw.com

APW

Carsten-Dressler Str. 10
28279 Bremen, Germany
49.421.8490.147 telephone
49.421.8490.151 fax
email: sales.backplanes@apw.com

APW

B.P. 60687, Rue de l'Industrie
60006 Beauvais Cedex, France
33.3.4402.8181 telephone
33.3.4402.5724 fax
email: sales.backplanes@apw.com

APW

Corso Lombardia
52 Regione Pescara
10099 S. Mauro Torinese, Italy
39.011.273.4352 telephone
39.011.273.5801 fax
email: sales.backplanes@apw.com

APW

14100 Danielson Street
Poway, CA 92064 U.S.A.
(800).367.3765 toll free
(858).679.4500 telephone
(858).679.4555 fax
email: sales.backplanes@apw.com
www.apw.com

APW - Corporate Office

N22 W23685 Ridgeview Parkway West
Waukesha, WI 53188-1013
262.523.7600 telephone
262.523.7588 fax

APW Ltd. is a privately held company incorporated in Bermuda, domiciled in Barbados, with a headquarters office in Waukesha, Wisconsin. With operations in numerous locations throughout Europe, Asia and the Americas, APW supports large OEMs and other customers around the world.

©APW Ltd. 2003

Printed in the United Kingdom

USA Distribution

Aero-Space Southwest Inc

21450 N. 3rd. Avenue,
Phoenix AZ 85027-2946 U.S.A.
(800).289.2779 toll free
(623).582.2019 fax
www.aerospacesw.com