

Low Profile Shear Force Load Cell

FEATURES

- Capacity 250, 500, 1000 and 2000 kN
- Other capacities on request
- Very low profile
- High long-term stability and repeatability
- Operating temperature range -40 to $+80^{\circ}\text{C}$ ($+125^{\circ}\text{C}$ with optional Teflon cable)
- 10 m special cable. Option: Load cell with connector
- Yellow Chromate Zinc plated steel
- Protection class IP67
- **OPTIONS**
 - Load cell can be customized to a large variety in dimensions and capacities
 - Customised adaptor plates and other mounting assemblies on request

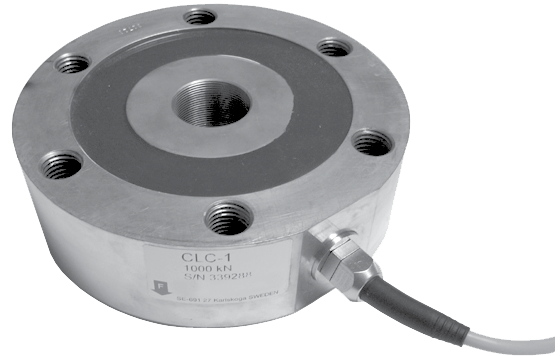

APPLICATIONS

- Silo and hopper weighing
- Tundish weighing
- Various applications in steel mills and foundries
- Industrial applications

DESCRIPTION

The model CLC-1 is a very low profile load cell, working according to the shear force principle (no membrane), ideally suited for applications in harsh environments.

Due to the special design, the CLC-1 load cell is insensitive against side loading and other interfering effects.

Because of the high operating temperature range of -40 up to $+125^{\circ}\text{C}$, the CLC-1 load cell is suitable for use in steel mills and foundries.

Due to the high repeatability and high long-term stability, the load cell supplies very good results, even after perennial use.

Protection class IP67 gives an excellent protection against dust and moisture.

OUTLINE DIMENSIONS IN MM

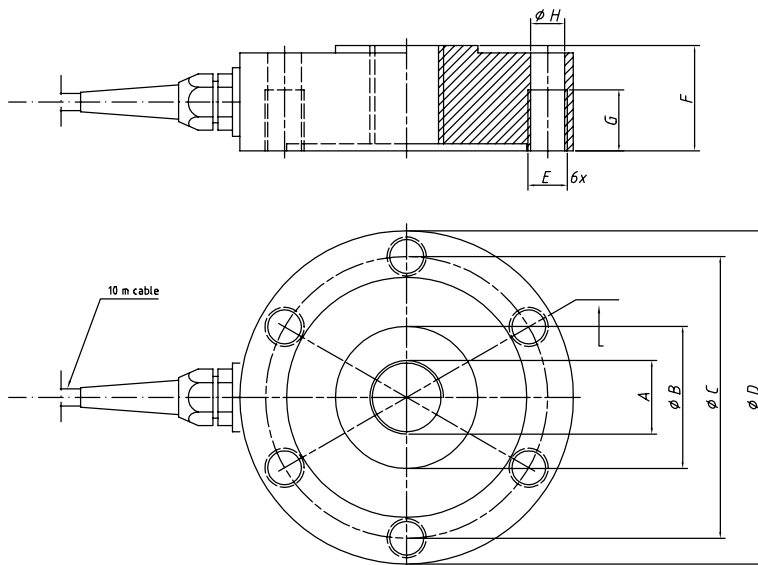

DIM.	25t	50t	100t	200t
A	M30 x 1,5	M30 x 1,5	M40x1,5	M55x1,5
B	58	58	85	120
C	115	115	164	220
D	136	136	195	263
E	M16	M16	M20	M24
F	43	43	58	67
G	25	25	30	40
H	13,5	13,5	18,5	21

Low Profile Shear Force Load Cell

SPECIFICATIONS	
PARAMETER	VALUE
Rated capacity (RC)	250, 500, 1000, 2000 kN
Rated output (C)	1 mV/V
Total error	±<0.1% of C
Temperature effect: on zero	±0.005% of C/°C
Temperature effect: on output	±0.005% of C/°C
Nominal temperature range	-10 to +80°C
Operating temperature range	-40 to +80°C (+125°C on request)
Safe overload	200% RC
Ultimate overload	>300% RC
Max. admissible side load	50% RC
Recommended excitation	10 VDC or VAC
Max. supply voltage	36 VDC or VAC
Input impedance	750 Ω ±15 Ω
Output impedance	700 Ω ±10 Ω
Insulation impedance	>2000 MΩ
Material	Yellow chromate zinc plated steel
Environmental protection	IP67

BLH Nobel is continually seeking to improve product quality and performance. Specifications may change accordingly.



Disclaimer

ALL PRODUCTS, PRODUCT SPECIFICATIONS AND DATA ARE SUBJECT TO CHANGE WITHOUT NOTICE.

Vishay Precision Group, Inc., its affiliates, agents, and employees, and all persons acting on its or their behalf (collectively, "VPG"), disclaim any and all liability for any errors, inaccuracies or incompleteness contained herein or in any other disclosure relating to any product.

The product specifications do not expand or otherwise modify VPG's terms and conditions of purchase, including but not limited to, the warranty expressed therein.

VPG makes no warranty, representation or guarantee other than as set forth in the terms and conditions of purchase. **To the maximum extent permitted by applicable law, VPG disclaims (i) any and all liability arising out of the application or use of any product, (ii) any and all liability, including without limitation special, consequential or incidental damages, and (iii) any and all implied warranties, including warranties of fitness for particular purpose, non-infringement and merchantability.**

Information provided in datasheets and/or specifications may vary from actual results in different applications and performance may vary over time. Statements regarding the suitability of products for certain types of applications are based on VPG's knowledge of typical requirements that are often placed on VPG products. It is the customer's responsibility to validate that a particular product with the properties described in the product specification is suitable for use in a particular application. You should ensure you have the current version of the relevant information by contacting VPG prior to performing installation or use of the product, such as on our website at vpgsensors.com.

No license, express, implied, or otherwise, to any intellectual property rights is granted by this document, or by any conduct of VPG.

The products shown herein are not designed for use in life-saving or life-sustaining applications unless otherwise expressly indicated. Customers using or selling VPG products not expressly indicated for use in such applications do so entirely at their own risk and agree to fully indemnify VPG for any damages arising or resulting from such use or sale. Please contact authorized VPG personnel to obtain written terms and conditions regarding products designed for such applications.

Product names and markings noted herein may be trademarks of their respective owners.

Copyright Vishay Precision Group, Inc., 2014. All rights reserved.