

Roll Force Measurement System



FEATURES

- Prevent mill overloading
- Increase roll life
- Control product quality
- Zero tracking with manual override
- Local and remote indication
- Easy retrofit for existing mills
- Direct replacement for RFS-3 and Model 56000 systems from BLH

DESCRIPTION

Rolling mill separation forces are measured accurately and conveniently with the RFS-4 system.

Extensometers on the mill posts or load cells in the screw provide an electrical signal proportional to the mill separation force. A G4 instrument with tailor made software read signals from both sides of the mill and amplify them.

The G4 have up to 8 channels to provide accurate and reliable information on sum (total), difference (work-drive), work total,

and drive total values that can be displayed on the graphic color display.

Analog signal outputs for each value are available on the rear panel rack terminals. Separate relay outputs are provided for "Metal in the Mill" and "Mill Overload" conditions.

APPLICATIONS

- Hot and cold rolling mills
- Overload Safety
- New and retrofit

CONFIGURATION

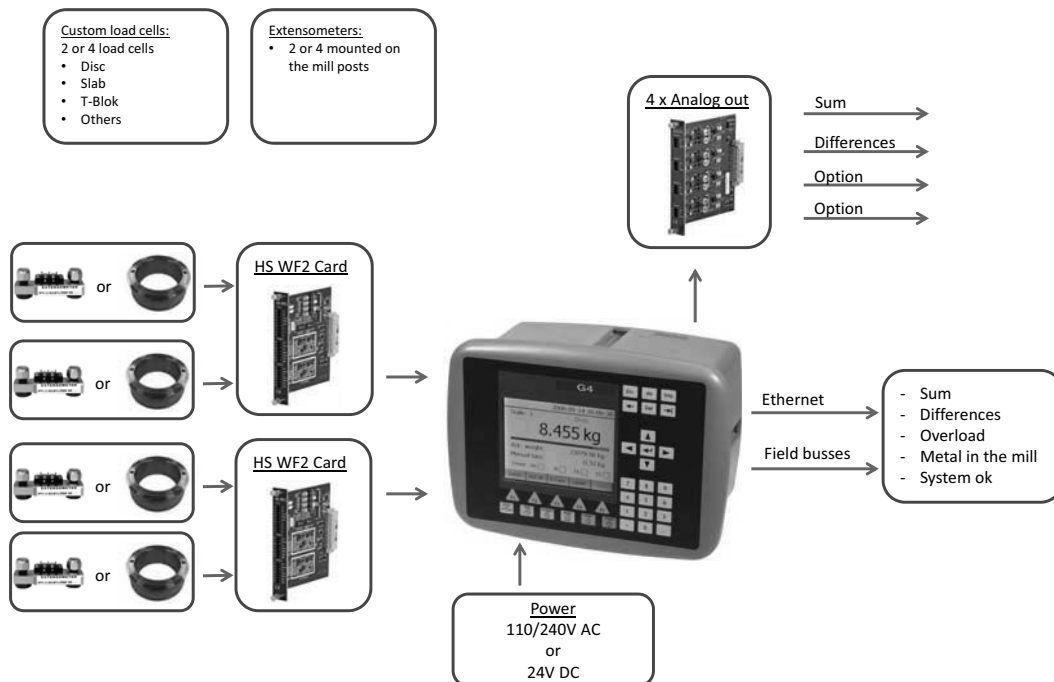

SPECIFICATIONS - CONTROLLER (G4)

Environmental			
Temperature range			
Rated performance	-10 to +50°C		
Storage	-25 to +85°C		
Protection	IP65 (panel)	IP65	IP65
EMC, RF	CE (Industrial), UL, cUL		
Display	Color TFT LCD screen with backlighting, 5.7" 320x240 pixels		
Keyboard	Touch screen and 34 membrane keys		
Power			
DC SUPPLY module	19-29VDC, 40W		
AC SUPPLY module	115/230VAC 50/60Hz, 40W		
CPU module:			
Interfaces:	Isolated		
RS232 and RS485, ports	For process data and control		
Protocol	Modbus RTU		
Baud rate	Up to 115 kbaud		
USB, supported units	Version 1		
Keyboard	USB keyboard for PC		
Memory stick	USB type for PC For backup and restore of set-up parameters. For change to a new program version		
Ethernet	For process data and control		
Protocol	Modbus TCP and EtherNet/IP		
Field bus or Industrial Ethernet, Optional	For process data and control		
Available field busses	Profibus or DeviceNet. CANbus, Ethernet/IS, ProfiNet and other on demand!		

OUTLINE DIMENSIONS - EXTENSOMETER

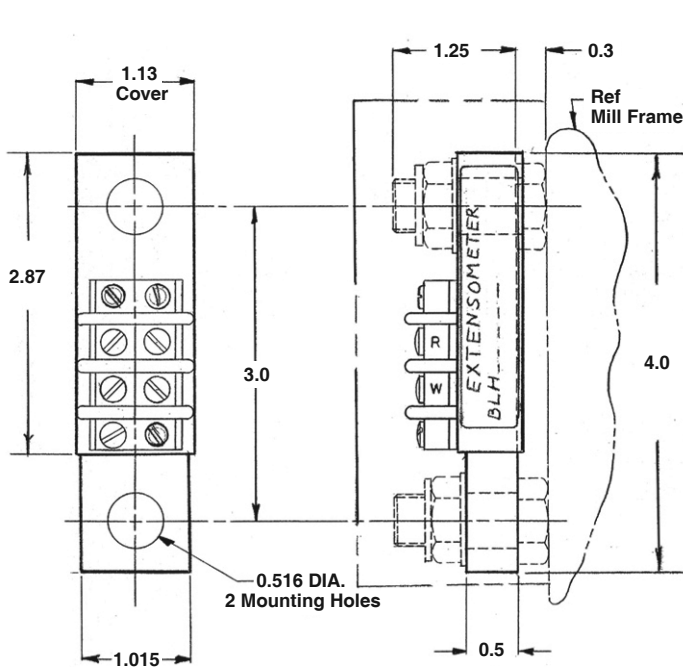

Extensometer Outline

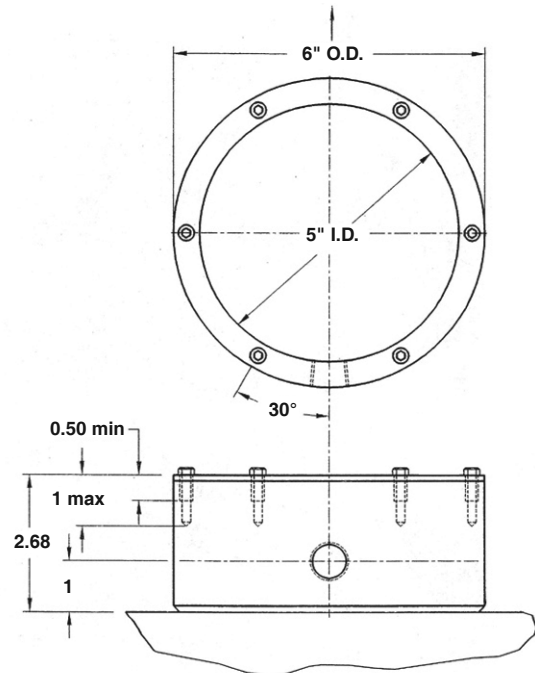

Cover Outline

SPECIFICATIONS - EXTENSOMETER

Accuracy ¹ :	<±0.85% of F.S.O.
Nonlinearity:	<±0.25% of F.S.O.
Hysteresis:	<±0.40% of F.S.O.
Repeatability:	±0.5% of F.S.O.
Calibrated output:	8mV/V ± 0.5% = 66.6µm/m (microstrain)
Overload capability	
Zero ² :	300% of F.S.O. (24mV/V)
Maximum:	550% of F.S.O. (44mV/V)

Strain bridge	
Input resistance:	525Ω ± 125Ω
Output resistance:	350Ω ± 50Ω
Insulation resistance:	5000MΩ
Excitation:	10V DC
Thermal effects (24°C to 65°C)	
Zero ³ :	±0.055%/°C of F.S.O.
Rated output:	±0.011%/°C of reading.
Operating temperature range:	-17°C to 121°C

Notes:

1. Accuracy is the Root Sum of the squares of nonlinearity, hysteresis, repeatability and span.
2. Cancelled by the instrument Zero Adjust capability.
3. The autozero capability of the instrument cancels any thermal zero shift.
4. Specifications only valid for extensometer, not application.

SPECIFICATIONS - LOAD CELL

All load cells are customized in specifications and dimensions.

Accuracy ¹ :	1.0% of RO
Nonlinearity:	0.5% of RO
Hysteresis:	0.5% of RO
Repeatability:	0.25% of RO
Calibrated output:	2mV/V
Capacity:	1-15MN
Strain bridge	
Input resistance:	350Ω ±5 (or 700Ω±10)
Output resistance:	350Ω ±5 (or 700Ω±10)
Insulation resistance:	5000MΩ
Excitation:	5-30V DC
Thermal effects	
Zero ² :	±0.04 %/°C of RO
Rated Output (RO):	±0.04 %/°C of reading.

Operating temperature range:
-40 to 100 °C, (more on demand).

Notes:

1. Accuracy is the Root Sum of the squares of nonlinearity, hysteresis, repeatability and span.
2. The autozero capability of the instrument cancels any thermal zero shift.
3. Specifications only valid for load cell, not application.

Disclaimer

ALL PRODUCTS, PRODUCT SPECIFICATIONS AND DATA ARE SUBJECT TO CHANGE WITHOUT NOTICE.

Vishay Precision Group, Inc., its affiliates, agents, and employees, and all persons acting on its or their behalf (collectively, "VPG"), disclaim any and all liability for any errors, inaccuracies or incompleteness contained herein or in any other disclosure relating to any product.

The product specifications do not expand or otherwise modify VPG's terms and conditions of purchase, including but not limited to, the warranty expressed therein.

VPG makes no warranty, representation or guarantee other than as set forth in the terms and conditions of purchase. **To the maximum extent permitted by applicable law, VPG disclaims (i) any and all liability arising out of the application or use of any product, (ii) any and all liability, including without limitation special, consequential or incidental damages, and (iii) any and all implied warranties, including warranties of fitness for particular purpose, non-infringement and merchantability.**

Information provided in datasheets and/or specifications may vary from actual results in different applications and performance may vary over time. Statements regarding the suitability of products for certain types of applications are based on VPG's knowledge of typical requirements that are often placed on VPG products. It is the customer's responsibility to validate that a particular product with the properties described in the product specification is suitable for use in a particular application. You should ensure you have the current version of the relevant information by contacting VPG prior to performing installation or use of the product, such as on our website at vpgsensors.com.

No license, express, implied, or otherwise, to any intellectual property rights is granted by this document, or by any conduct of VPG.

The products shown herein are not designed for use in life-saving or life-sustaining applications unless otherwise expressly indicated. Customers using or selling VPG products not expressly indicated for use in such applications do so entirely at their own risk and agree to fully indemnify VPG for any damages arising or resulting from such use or sale. Please contact authorized VPG personnel to obtain written terms and conditions regarding products designed for such applications.

Product names and markings noted herein may be trademarks of their respective owners.

Copyright Vishay Precision Group, Inc., 2014. All rights reserved.