

G4 PROGRAM DESCRIPTION

Program: G4MI_101.0.124.0



Program for Torque and Chatter Measurement

This description is valid for:

G4 Multi Channel Force Instrument with application program **101.0.124.0**

See also the following descriptions

G4 Multi Channel Force Instrument, Technical Manual PM/DT/HE/RM

(www.vishaypg.com/doc?35148)

If these descriptions in any case are contradictory, this description is valid.

Function

This special program adds function to measure torque from a sensor signal and monitor the rapid fluctuation of the torque signal value (chatter) and displaying them both on the display of the G4 as well as sending them to analogue outputs and communication ports.

The program can be used in all G4 instrument, both with graphical display (PM/HE/DT) and din rail mounted (RM).

General

Measurement is done using the HSWF2 - High speed weight/force, dual input module. The two analog inputs on the module is connected to one torque sensor and one of the inputs is highly filtered to measure the slow changes in the torque value and the other input is not filtered in order to measure the fast changes (chatter) of the signal. One or two of HSWF2 modules can be used for measuring the torque/chatter in one or two machines.

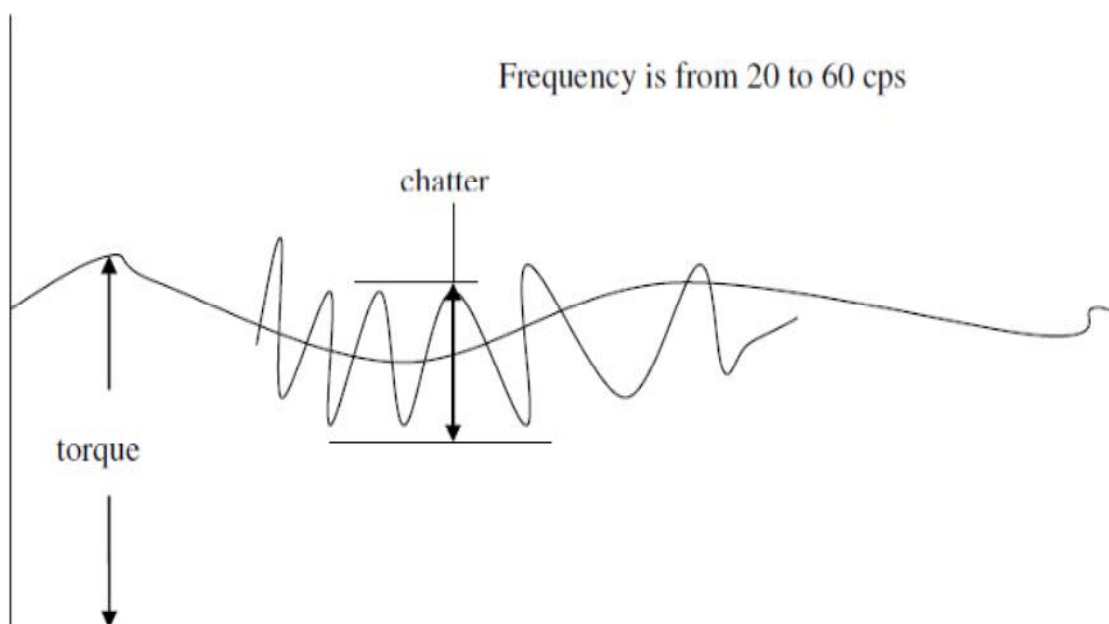

Definition of torque and chatter in the sensor signal

Operation

Function block 1 (and 3) will display the 'torque' value which is defined as a highly filtered signal from the torque sensor. The update rate for this channel is set to 25 Hz which will give a bandwidth of 2.6 Hz (-3 dB).

Function block 2 (and 4) will display the 'chatter' value which is defined as the unfiltered signal from the torque sensor. The update rate for this channel is set to 800++ Hz which will give a bandwidth of 87 Hz (-3 dB).

The normal display will show both 'Torque' and 'Chatter' value

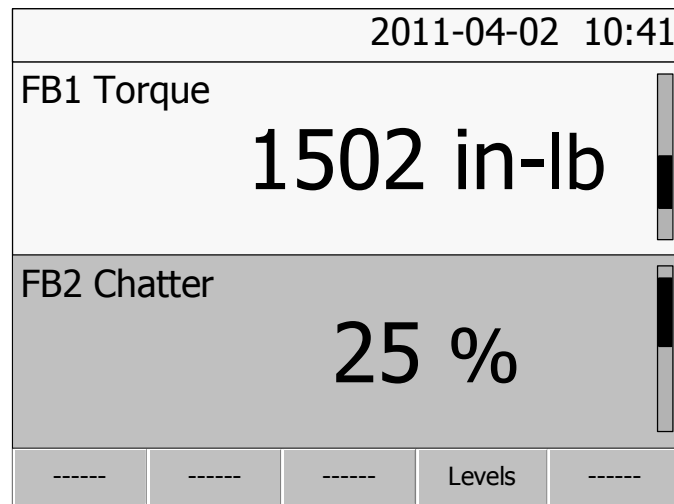

Chatter is measured as the difference between 'peaks' and 'valleys' in the fluctuation of the torque up to roughly 60 Hz.

The displayed chatter value is then represented by a floating mean value of the ten latest measured chatter values, scaled to the max torque value (set in set-up parameter 'Sum Graph Max' for the actual torque channel) so that 100% chatter is displayed when the chatter mean value is equal to 10 % of the max torque value.

Or shown in a formula

$$\text{Displayed chatter} = \frac{\text{mean chatter value}}{0.1 * \text{max torque value}} \times 100 \%$$

Chatter below 1 Hz or below 1% of current torque value will not be measured and will be seen as 0% chatter.

Chatter is not measured if the torque value is below 100 times force resolution, that means that if torque force resolution is '1' in-lb, chatter is not measured if torque value is below 100 in-lb

Parameters

It is only possible to use '1 Channel' function blocks in this application, so the choices for '2 Channel' and '4 Channel' function blocks has been removed.

A new unit 'in-lb' has been added to parameter 'X: Measurement Unit'

The parameter '1: Sum Graph Max' (or '3: Sum Graph Max') should be set to the maximum torque value (normally the nominal value of the torque sensor). This value is used when scaling the chatter value so that 100% chatter is equal to 10% of this value.

The following parameters have got new default values

Parameter		New default value
Slot 1 Module Type		HSWF2
Function Block 1 (and 3): Name		Torque
Function Block 1 (and 3): Measurement Unit		in-lb
Function Block 1 (and 3): Update Rate		25 Hz
Function Block 2 (and 4): Name		Chatter
Function Block 2 (and 4): Measurement Unit		%
Function Block 2 (and 4): Update Rate		800++ Hz

All parameters for 'Table' and 'Known Force' calibration for the of function block 2 (and 4) has been removed when these channels use the calibration done for function block 1 (and 3).

All other parameters should be configured as desired for the application as described in the 'Technical Manual'.

Connection

The torque sensor (transducer) should be connected to channel 1 and 2 of one HSWF2 module as shown in the figure below.

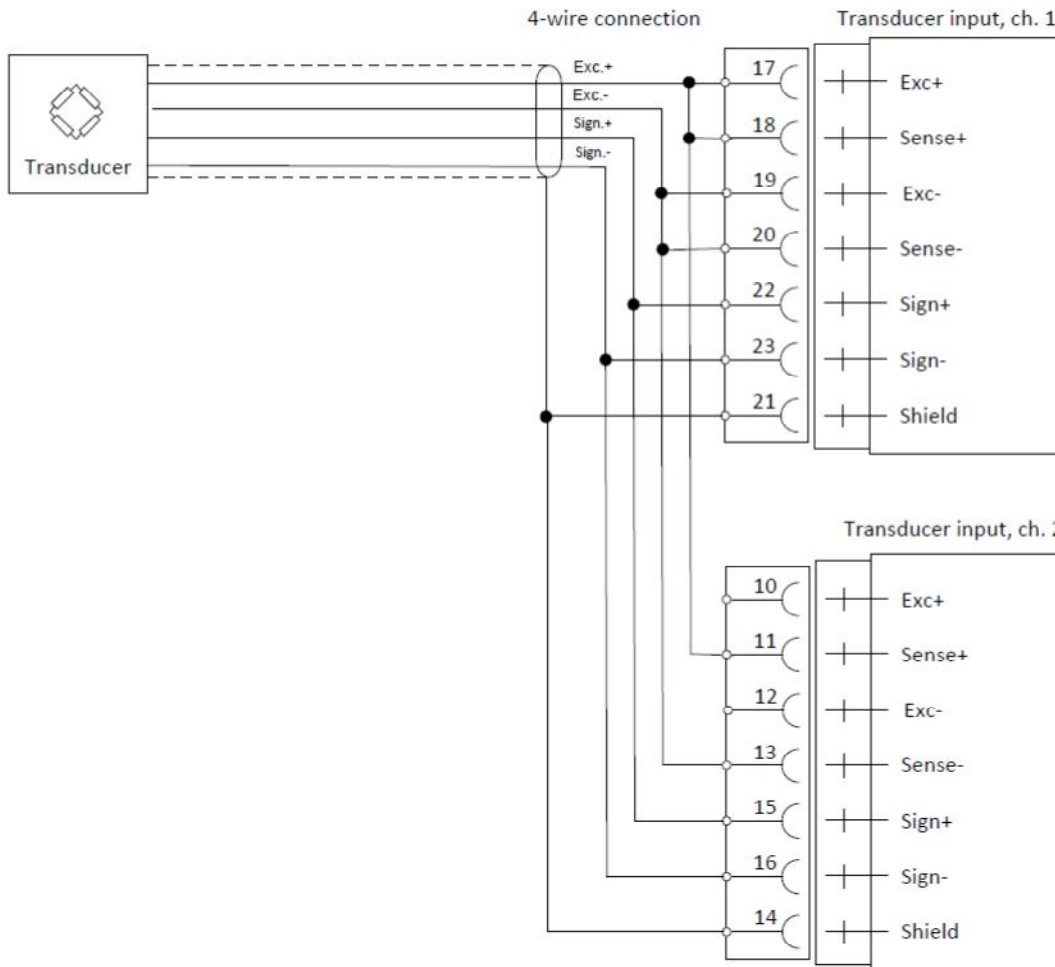

Channel 1 should be configured to be the input for Function block 1 to measure the torque value.

Channel 2 should be configured to be the input for Function block 2 to measure the chatter value.

If a second HSWF2 module is used Channel 1 in this module should be configured to Function block 3 and Channel 2 configured to Function block 4.

Document no. 35025
PG4MI_101_0_124_0_E1R2
© Vishay Nobel AB, 2011-10-20
Subject to changes without notice, set forth at www.vishaypg.com/doc?63999.

Vishay Nobel AB

Box 423, SE-691 27 Karlskoga, Sweden
Phone +46 586 63000 · Fax +46 586 63099
pw.eur@vishaypg.com
www.weighingsolutions.com