

PROGRAM DESCRIPTION

TAD 3

Program: T113A210

This description is valid for:

Weight indicator **TAD 3** with application program **T113A210**

See also the following descriptions

Weight Indicator TAD 3, Operating instructions, Quick installation

Weight Indicator TAD 3, Technical Manual

If these descriptions in any case are contradictory, this description is valid.

Option codes: **This program requires program option codes for**
02: **Flow rate**
06: **Option 6**

General

Two TAD3 instrument measures the flow out of two vessels. The two TAD3 are connected to each other and the 'master' TAD contains the special software that gets the flow value from the 'slave' TAD (standard software with option flow rate) and calculates and displays the relative flow value in percent with two decimals $(B / A+B) * 100$.

TAD3Slave = A
TAD3Master = B.

The 'master' TAD3 continuously reads the flow value from TAD with address no. 2.

New level x source special parameter implemented. This new parameter get the relative flow to work with levels 1 – 8 (absolute values) like standard software.

Possible to freeze the relative flow and levels with an input.

Indications

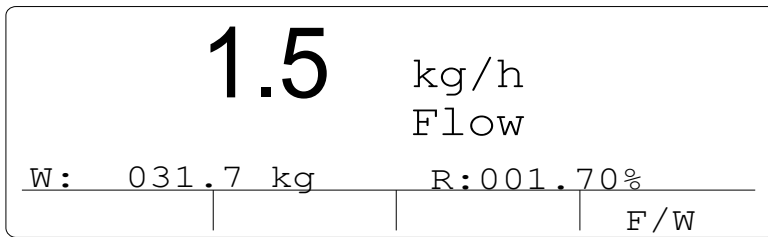

TAD3 will display relative flow at the information line (small 'standard' weight bar removed in this software) if the set-up parameter 'Display info' in Edit set-up/General is set to 'Off'.

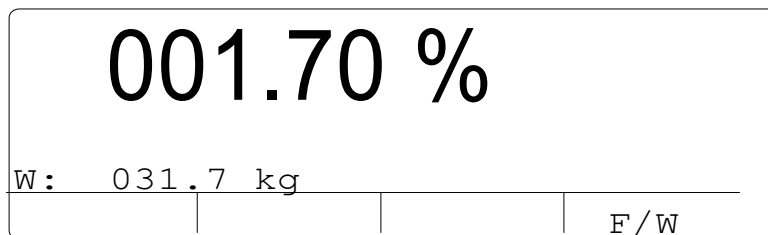

TAD3 will display relative flow at the normal display position if function key 'F3' (toggle) is activated. This key will over ride the normal display.

Flow rate measurement

See chapter 8 in TAD 3 Technical Manual.

Changed set-up parameters

Following set-up parameters is changed (new default values or changed choice).

Menu "General"

Display info

< Off > New default value.

New set-up parameter

Menu "Level supervision"

Level 1 - 8 source

[11] Special New source Special: The level operates on the relative
< Not in use > flow value in percent (absolute values).

New Input

TAD 3 Input 1 Freeze relative flow and levels connected to relative
flow.

NOTE. Freeze relative flow is NOT selectable works always on input 1 (not displayed and selectable in Menu 'Inputs')

Relative flow error indications

Will occur if following:

- One of the instruments is **NOT** in normal state and if weight errors is detected
- Communication error between master and slave.
- One of the Flow rate values = 0
- TADSlave flow rate + TADMaster flow rate = 0

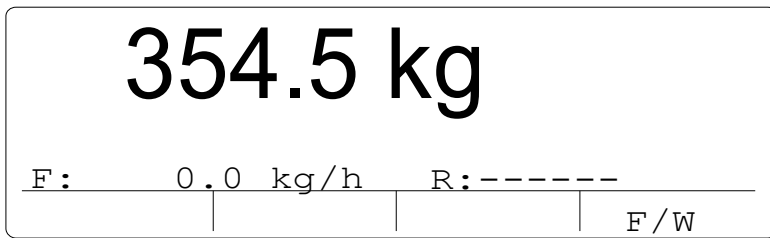

Display of indication line error

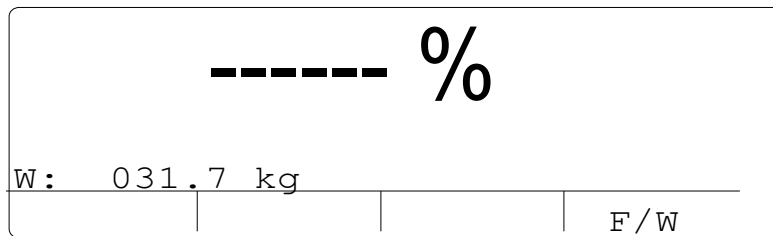

Display of normal display line error

Relative flow levels

Relative flow levels outputs are set passive when errors occur.

Electrical installation

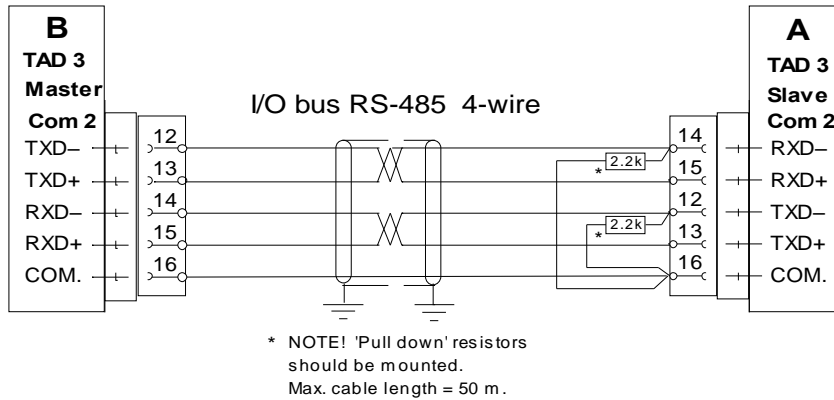

Menu "Communication"

Settings:

TAD3 Master 'B'

COM2:Mode

[7] I/O bus
< I/O bus >

The serial port NEAB I/O bus. (Master).
NOTE. Possible to add DIO 3 and ANA 3 units.

TAD3 Slave 'A'

Instrument. Address = 2

COM2 :Mode

[2] Modbus auto
< I/O bus >

The instrument works as a slave.

Document no. 35060

T113V2E

© Vishay Nobel AB, 2011-10-21

Subject to changes without notice, set forth at www.vishaypg.com/doc?63999.

Vishay Nobel AB

Box 423, SE-691 27 Karlskoga, Sweden

Phone +46 586 63000 · Fax +46 586 63099

pw.eur@vishaypg.com

www.weighingsolutions.com