

Robust and Accurate Tank Weighing in hazardous Area (ATEX)

Application: Process Weighing
Industry Sector(s): Oil and Gas

The Customer

A producer of mud handling equipment.

Customer Inquiry

The customer was seeking high-quality load cells for tank weighing in environments with harsh conditions, including explosive atmospheres. Its goal was to identify a supplier that would not only provide the appropriate technical solution but also work with them as a team player.

Solutions and Equipment

VPG Process Weighing supplied the customer with standard KOM-1 and KIMD-1 load modules with a special cable. This gave them a simple but very robust weighing solution with all the accuracy needed for this type of system.

Equipment:

- KOM-1BM / 100kN load cell with ATEX approval
- KIMD-1BM / 800kN load cell with ATEX approval
- Adapter plates for easy mounting.

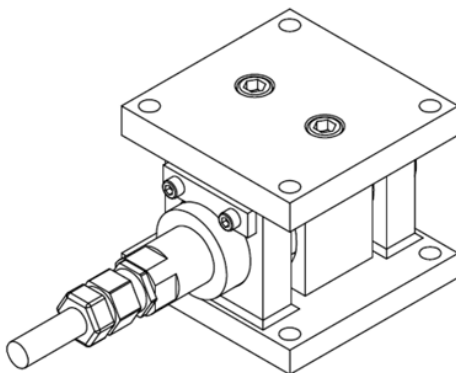

Figure 1: KOM-1BM 100kN

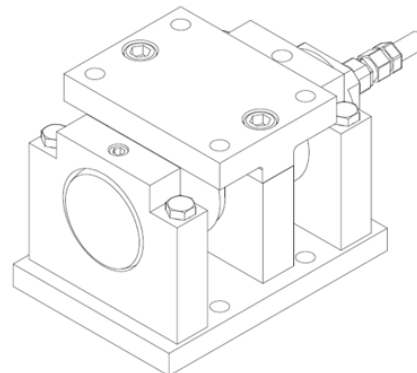

Figure2: KIMD-1BM 800kN

Key Features:

- Easy mounting
- High accuracy
- Robust for harsh environment

Customer Comments

“The load modules from Nobel Weighing Systems were a perfect match with our specifications on all counts.”

“Perfect products for offshore environment”



Figure 3: Jack up rig

Contact Information

Americas

blhnobel.usa@vpgsensors.com

Asia

blhnobel.asia@vpgsensors.com

Europe

blhnobel.eur@vpgsensors.com