



BLH

**Model LCp-100/200 Interface Manual
Allen-Bradley Remote I/O**

NOTICE

BLH makes no representation or warranties of any kind whatsoever with respect to the contents hereof and specifically disclaims any implied warranties or merchantability or fitness for any particular purpose. BLH shall not be held liable for errors contained herein or for incidental or consequential damages in connection with the furnishing, performance, or use of this publication or its contents.

BLH reserves the right to revise this manual at any time and to make changes in the contents hereof without obligation to notify any person of such revision or changes.

Call (781) 298-2216 for BLH Field Service

Table of Contents

SECTION 1.	Introduction.....	1-1
1.1	RIO OVERVIEW.....	1-1
1.2	THE LCp-100/200 INSTRUMENT.....	1-1
1.3	ALLEN-BRADLEY PLC-5 PROGRAMMABLE CONTROLLER.....	1-1
1.4	FIELD ENGINEERING.....	1-2
SECTION 2.	The Remote I/O Interface.....	2-1
2.1	OPERATIONAL OVERVIEW.....	2-1
2.2	INTERFACE CONFIGURATION.....	2-1
2.3	DISCRETE DATA TRANSFER.....	2-3
2.3.1	Output Image Table.....	2-3
2.3.2	Input Image Table.....	2-4
	Figure 2-3. The Input Image Table.....	2-4
2.4	BLOCK DATA TRANSFERS.....	2-5
2.4.1	INterface Basics.....	2-5
2.4.2	Block Transfer Reads (BTRs).....	2-5
2.4.3	Block Transfer Writes (B1Ws).....	2-5
2.4.4	The Pointer.....	2-5
2.4.5	Fault Evaluation.....	2-5
2.4.6	Remote Filter Configuration.....	2-5
SECTION 3.	Definitions and Explanations.....	3-1
3.1	INPUT IMAGE TABLE BITS.....	3-1
3.2	OUTPUT IMAGE TABLE BITS.....	3-2
SECTION 4.	Troubleshooting.....	4-1
4.1	GENERAL.....	4-1
4.1.1	Rear Panel Status LED.....	4-1
4.1.2	Front Panel Status Display.....	4-1

Appendix A - Outline and Wiring Diagrams

Trademark Usage Acknowledgment

Allen-Bradley, ENABLED, and PLC are trademarks of Men-Bradley Company, Inc.

SECTION 1.

Introduction

This manual describes an Allen-Bradley Remote I/O (RIO) communication link between a BLH LCp-100 or LCp-200 weight indicator/transmitter and an Allen-Bradley PLC-5 (Figure 1-1). This interface method uses technologies licensed by BLH from Allen-Bradley. Functionally this digital communication method provides a simple method of transferring various types of weight data, status and diagnostic information as well as the retrieval and download of calibration, filter, and other set-up parameters. Refer to the LCp-100 or LCp-200 manual for operating procedures and parameter definitions.

1.1 RIO OVERVIEW

The Allen-Bradley Remote I/O (RIO) interface is a communications link that supports remote, time critical I/O control communications between a master processor and a remote I/O slave. It is typically used to transfer I/O bit images between the master and slave. The LCp unit represents a quarter (1/4) Rack of discrete I/O with 32 bits of input and output image files to the scanning PLC. All weight data and status information uses discrete reads and writes to communicate scale information to the PLC in the shortest time possible. Block transfers are used to upload weight, status, calibration, and configuration data, and download calibration and configuration data.

1.2 THE LCp-100/200 INSTRUMENT

LCp-100 and LCp-200 instruments are high performance weight indicator/ transmitter/ controllers with features suitable for both inventory and process weighing applications. Both units offer microprocessor based electronics to digitize load cell signals, and provides outputs in the form of serial RS-485/1422, analog 4-20 mA, and Allen-Bradley Remote I/O communication ports.

Standard units are housed in a panel mount configuration. Optional enclosures are available for field mounting. Upon request, units also are available with CSA certification for installation in a Class I, II, III Division 2 hazardous locations. Set-up and calibration procedures are accomplished using the front panel configuration keys and display (reference operator's manual). Also, known set-up and calibration parameters can be downloaded from the host PLC. In operation, they provide up to 750,000 counts of weight resolution and a sample rate of 50 milliseconds.

The LCp-200 has all the features and capabilities of the LCp-100, plus *set points* and *rate-by-weight* function. In this manual, functions which pertain to both instruments appear in normal text. Functions which pertain only to LCp-200 units appear italic text.

1.3 ALLEN-BRADLEY PLC-5 PROGRAMMABLE CONTROLLER

The Allen-Bradley PLC-5 series of mid-size programmable controllers are used as part of distributed process automation architecture. A variety of 1771 series racks and I/O modules are available for local or remote discrete and analog process control. The PLC-5 can digitally communicate to other devices using a conventional RS 232 or 423 serial port in addition to special interface ports such as Data Highway Plus, Scanner Communications, and Remote I/O Adapter.

NOTE: Now the SLCO5 small logic controllers also are available with a Remote I/O scanner port.

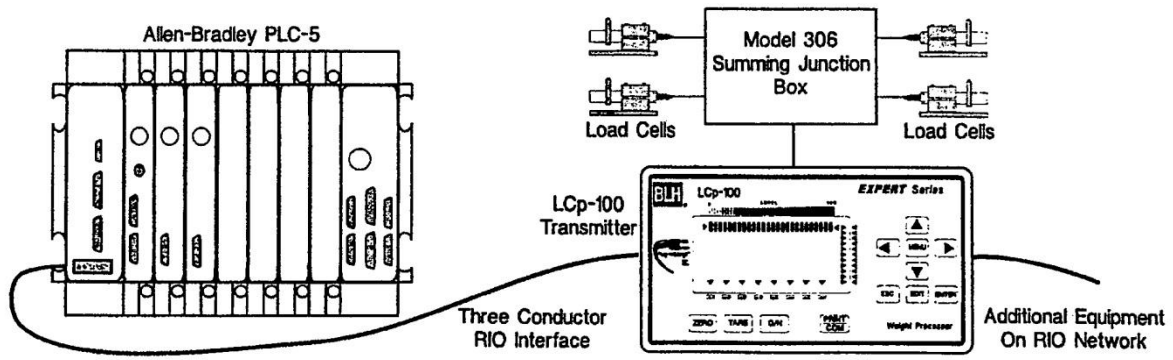

Figure 1-1. Allen-Bradley Remote I/O Network Interface

1.4 FIELD ENGINEERING

BLH will not accept any liability for faulty installation and/or misuse of this product. Authorized BLH Field Service Engineers are available around the world to install LCp transmitters and/or train factory personnel to do so. The field service department at BLH is the most important tool to assure the best performance from your application. Field service phone numbers are listed below.

Notice:

BLH makes no representation or warranties of any kind whatsoever with respect to the contents hereof and specifically disclaims any implied warranties or merchantability or fitness for any particular purpose. BLH shall not be held liable

for errors contained herein or for incidental or consequential damages in connection with the furnishing, performance, or use of this publication or its contents.

BLH reserves the right to revise this manual at any time and to make changes in the contents hereof without obligation to notify any person of such revision or changes.

**Field Service Phone Numbers
Call (Factory Number)
(781) 298-2200
Ask for Field Service
Canada
(416) 251-2554
(800) 567-6098**

SECTION 2. The Remote I/O Interface

2.1 OPERATIONAL OVERVIEW

The Allen-Bradley Remote I/O (RIO) interface is standard on many PLC-2, 3, and 5 series programmable logic controllers and optional on the SLCO5 controllers. The technology used in the interface and licensed by Allen-Bradley to BLH enables the LCp transmitter to communicate weight and status information to the PLC as if it were a 1/4 rack of discrete I/O. By using the standard RIO interface port and representing weight data as simple discrete I/O, a low cost reliable, easy to use, communication link between the PLC and weigh system is established. All live weight data is available through discrete transfers. If the value is less than 32,767, no conversions are necessary. For values greater than 32,767, PLC ladder logic instructions will convert image table data to floating point values. The LCp also supports block transfers of data. Non time critical diagnostics and download of set-up parameters can be communicated using block transfer read and write sequences.

CONFIGURATIONS:

One Quarter Rack. The LCp is configured to act as 1/4 rack of I/O using 2 input words and 2 output words in the PLC's I/O image table. LCp addressing supports rack addresses 0-77 (octal) and identification of position in rack. For example, four LCps constitute 1 full rack, each using a different starting quarter.

Discrete Transfer. Weight data and operating status information is transmitted continually through discrete transfer using the PLC's Remote I/O image table.

Block Transfer. Block data transfers are initiated by the PLC ladder logic program (BM and BIW instructions) to obtain weight, status, calibration, and configuration (menu parameters) data. Block transfers are controlled by discrete transfer data.

Word Integrity Is Ensured. The LCp will always transmit both input image table words intact. To ensure word integrity on the PLC side, immediate writes to the output image table should be written low word first.

2.2 INTERFACE CONFIGURATION

Baud rate, rack address, starting quarter, and last rack designations are all configured through the LCp I/O sub-menu (Figure 2-1, next page).

Access the I/O sub menu (reference operator's manual for keypad functions), step to the I/O RIO display, and make selections. The LCp is able to be addressed up to rack number 77 (octal).

Additional Figure 2-1 information provides a relationship table for baud rate, cable length, last rack termination resistance, and the number of LCps on the RIO loop. Careful consideration must be given to all four factors to ensure proper RIO loop operation.

Allen-Bradley RIO Interface Flow Diagram

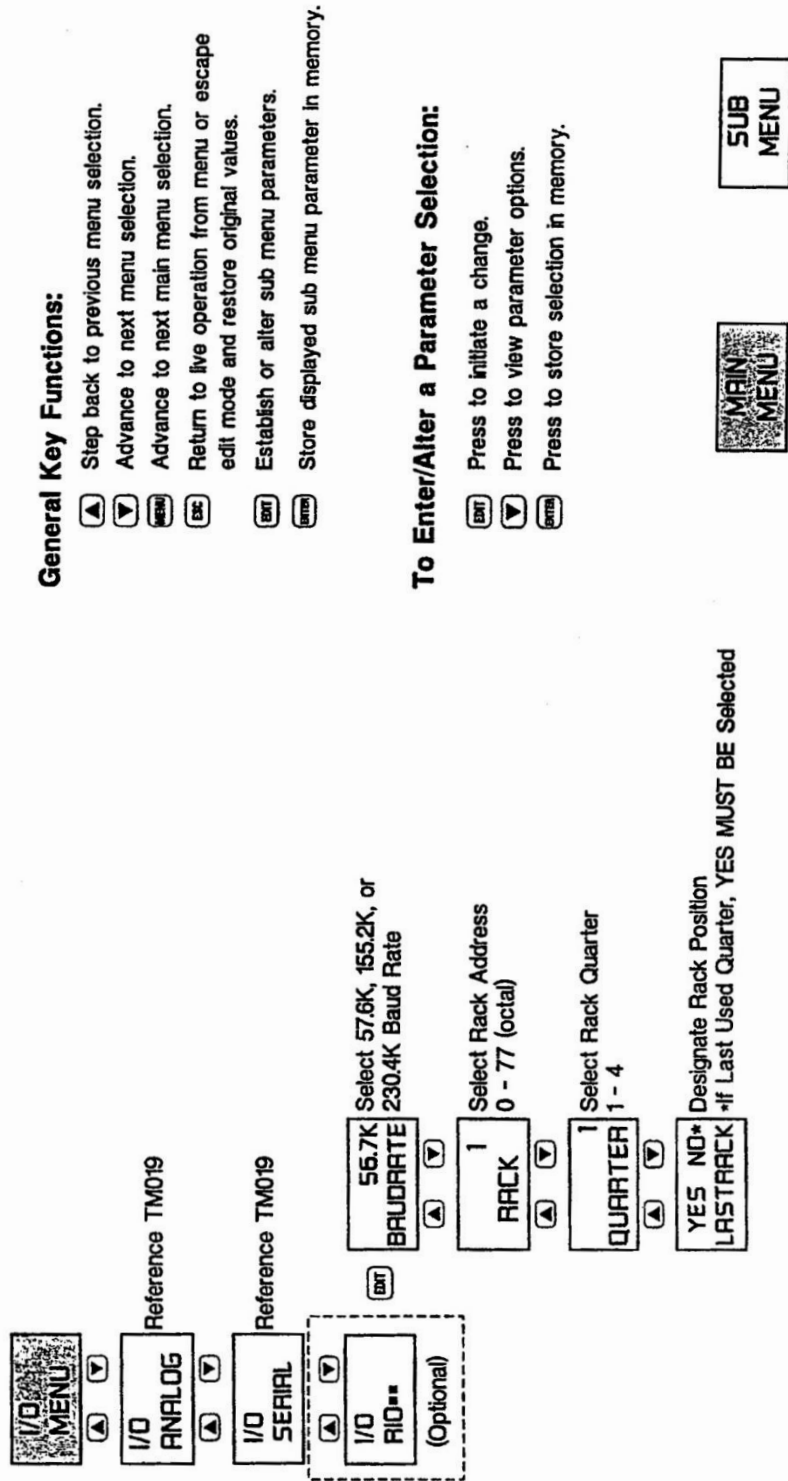

General Key Functions:

- ▲ Step back to previous menu selection.
- ▼ Advance to next menu selection.
- MENU Advance to next main menu selection.
- ESC Return to live operation from menu or escape edit mode and restore original values.
- ENT Establish or alter sub menu parameters.
- ENTER Store displayed sub menu parameter in memory.

To Enter/Alter a Parameter Selection:

- ENT Press to initiate a change.
- ▼ Press to view parameter options.
- ENTER Press to store selection in memory.



Cable Lengths, Terminations, and Maximum # Of LCp Units

BAUD RATE	MAXIMUM CABLE LENGTH	TERMINATION FOR LAST LCp ON CABLE	MAXIMUM LCps PER SCANNER
57.6K	10,000 FEET	150 OHMS	16 Units
115.2K	5,000 FEET	150 OHMS	16 Units
230.4K	2,500 FEET	82 OHMS	32 Units

Figure 2-1. LCp-100 RIO Interface Parameters

2.3 DISCRETE DATA TRANSFER

2.3.1 OUTPUT IMAGE TABLE

The PLC-5 initiates the communication interface by transmitting two words from the output image table (Figure 2-2). The first word is regarded as a 'spare' by the LCp.

The second word contains the commands that the PLC-5 expects the Lep to perform. In addition to LCp operating mode status, Word 2 controls

basic LCp operations; data selection, push to zero, tare, and print keys.

Contents of the data portion of the input image table (see next page) are identified by the three ID bits in word 2 of the output image table. For example, setting the data ID bits to 1 1 0 will format the input image table data to contain diagnostic status bits.

Word 1



Word 2

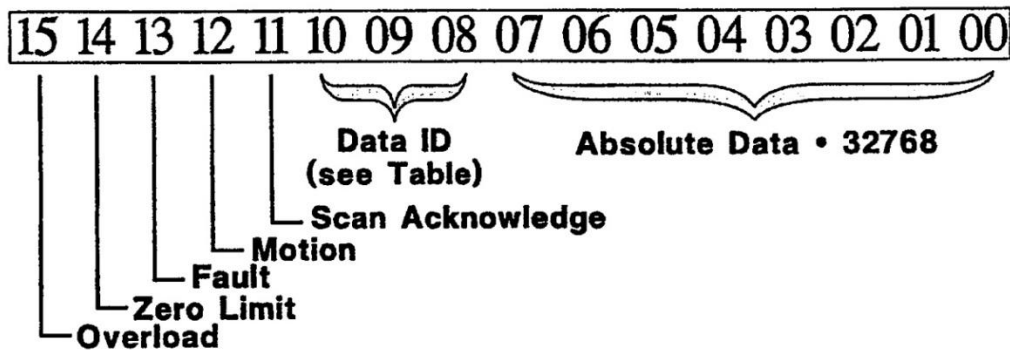

Data ID Table

10	09	08	
0	0	0	= Gross Weight
0	0	1	= Net Weight
0	1	0	= Actual mV/V Signal
0	1	1	= Live mV/V Signal
1	0	0	= Zero Value
1	0	1	= Tare Value
1	1	0	= Fault Status*
1	1	1	= Rate

* **NOTE:** When data ID in the output image table is set to format the data for fault status, data bits represent diagnostic status as follows:

Word 1

STAT 1, STATUS Register 1

- BIT 0 - POWERUP
- BIT 1 - UNABLE TO TARE/ZERO BECAUSE OF MOTION
- BIT 2 - UNABLE TO ZERO BECAUSE OF LIMIT
- BIT 3 - A/D UNDERRANGE
- BIT 4 - A/D OVERRANGE
- BIT 5 - A/D CONNECT FAULT
- BIT 6 - D/A UNDERRANGE
- BIT 7 - D/A OVERRANGE
- BIT 8 - D/A OPEN CIRCUIT
- BIT 9 - NO mV/V CAL
- BIT 10 - NO ENGINEERING CAL
- BIT 11 - NO TEMPERATURE COMPENSATION
- BIT 12 - NO MANUAL ZERO
- BIT 13 - NO MANUAL TARE
- BIT 14 - EEPROM ERROR
- BIT 15 - SPARE

Word 2 bits 0 - 5
spare

Figure 2-2. The Output Image Table

2.3.2 INPUT IMAGE TABLE

After evaluating the contents of the output image table, the LCp responds by transmitting two words to the input image table (Figure 2-3). The first word contains signed integer weight data or fault status (see table below). The second word

contains the upper order data bits, system status, and fault condition.

Word 1

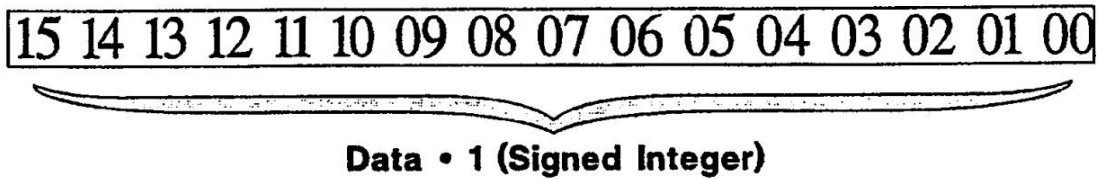

Word 2

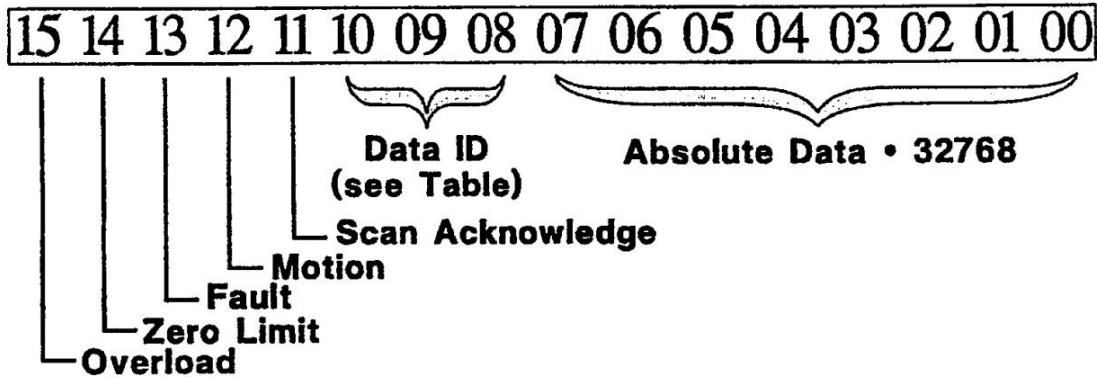

Data ID Table

10	09	08	
0	0	0	= Gross Weight
0	0	1	= Net Weight
0	1	0	= Actual mV/V Signal
0	1	1	= Live mV/V Signal
1	0	0	= Zero Value
1	0	1	= Tare Value
1	1	0	= Fault Status*
1	1	1	= Rate

* **NOTE:** When data ID in the output image table is set to format the data for fault status, data bits represent diagnostic status as follows:

Word 1

STAT 1, STATUS Register 1

- BIT 0 - POWERUP
- BIT 1 - UNABLE TO TARE/ZERO BECAUSE OF MOTION
- BIT 2 - UNABLE TO ZERO BECAUSE OF LIMIT
- BIT 3 - A/D UNDERRANGE
- BIT 4 - A/D OVERRANGE
- BIT 5 - A/D CONNECT FAULT
- BIT 6 - D/A UNDERRANGE
- BIT 7 - D/A OVERRANGE
- BIT 8 - D/A OPEN CIRCUIT
- BIT 9 - NO mV/V CAL
- BIT 10 - NO ENGINEERING CAL
- BIT 11 - NO TEMPERATURE COMPENSATION
- BIT 12 - NO MANUAL ZERO
- BIT 13 - NO MANUAL TARE
- BIT 14 - EEPROM ERROR
- BIT 15 - SPARE

Word 2 bits 0 - 5
spare

Figure 2-3. The Input Image Table

2.4 BLOCK DATA TRANSFERS

2.4.1 INTERFACE BASICS

Block data transfers are initiated by the ladder logic program write (B1VV) and read (B1R) commands. The transfer sequence begins when the PLC sends the LCp a one word (16 bit integer) write command containing a register location pointer. This pointer is the 16 bit integer value of the first register the PLC wishes to read (factory default upon shipment is register 1).

Table 2-1 presents all available register locations. *Locations printed in italic text apply only to LCp-200 units.* After establishing the starting register location, the PLC then transmits a read transfer block command telling the LCp how many words of information are needed.

2.4.2 BLOCK TRANSFER READS (BTRS)

Once the register location pointer value is established, the PLC logic program must issue a block transfer read command to obtain LCp information. A BTR can request up to 64 words of LCp information (see Table 2-1). The LCp will respond to the BTR by transmitting the number of words requested, starting at the pointer location. NOTE: The first word transmitted by the LCp will be the register pointer value. The LCp adds this word at the beginning of the transmission to 'echo' the pointer value prior to transmitting requested data. Therefore, the BTR command MUST add 1 to the number of words requested. If the PLC needs two words of LCp information, the BTR request must be for three words (Figure 2-4).

WORD 1	WORD 2	WORD 3
Register	Gross Weight	Gross Weight
Address 12	Low Word	High Word

Block Transfer Read Sample: Two words decked (system gross weight) requires three word read command (3rd word is echo of starting address).

Figure 2-4. Block Transfer Read Example

2.4.3 BLOCK TRANSFER WRITES (B1WS)

Registers 20 thru 127 may be written to by the PLC (see Table 2-1). This allows parameters such as filter values to be down loaded on-the-fly by the PLC ladder logic program. Men writing to the LCp, the first word must be the register location pointer (Figure 2-5). Therefore, the program MUST always add 1 to the BTWV command length. For example, to change a filter value, the B1W length must equal 2 with the first word being the filter register location pointer and the second word being the new filter setting.

WORD 1	WORD 2
Register	Averaging
Address 108	Setting

Block Transfer Write Sample: One word decked (new averaging selection) requires two word write command (1st word is address).

Figure 2-5. Block Transfer Write Example

2.4.4 THE POINTER

The pointer remains the same until changed. The pointer location defaults to '1' upon power-up.

2.4.5 FAULT EVALUATION

Two status words, register locations 10 and 11, provide detailed explanations of error conditions encountered by the LCp. When a fault is detected, bit 6 (fault) in word 2 of the input image table is set to a '1' to alert the PLC of an error condition. The PLC then performs a BTR of the appropriate status register to evaluate and correct the error. If bit six (fault) is set, check the status words for the error explanation. Table 2-2 gives the status word bit definitions.

Reminder: Fault data also is available through discrete transfer.

2.4.6 REMOTE FILTER CONFIGURATION

The Dynamic Digital Filter can be instructed by the PLC to change filter settings on-the-fly. This unique feature allows optimal, pre-determined filtering parameters to be implemented at critical

moments during a dynamic weigh process. Changing filter parameters throughout the process ensures data stability and maximum

system response to actual weight changes. Filter parameters are stored at register locations 108 and 109 (Table 2-1).

Table 2-1. Block Transfer Register Allocations/Definitions
Registers 1 - 19 and 139 - 142 are read only; all others are read/write

REG#	DATA	REGS	DESCRIPTION
1-4	SERIAL #	4	7 ASCII digits 0-9 starting with low byte of reg 1 to low byte of reg 4; reg 4 high byte = 0
5	SOFTWARE VER	1	number with 2 decimal places (i.e. 100 = ver. 1.00)
6	A/D REV	1	2 ASCII chars starting with low byte
7-9	REF DATE	3	6 ASCII digits 0-9 starting with low byte of reg 7 to high byte of reg 9 format = MMDDYY Month Day Year of internal cal
10	STAT1	1	status register 1 (see Table 2-2)
11	STAT2	1	status register 2 (see Table 2-2)
12-13	GROSS WEIGHT	2	System Gross Weight Value
14-15	NET WEIGHT	2	System Net Weight Value
16-17	mV/V ACTUAL	2	
18-19	mV/V LIVE	2	
20-21	ZERO	2	Zero Value
22-23	TARE	2	Tare Value
24-25	ZERO mV/V	2	cal zero in mV/V
26-27	SPAN1 mV/V	2	cal span1 in mV/V
28-29	SPAN1 units	2	cal span1 in units
30-31	SPAN2 mV/V	2	cal span2 in mV/V
32-33	SPAN2 units	2	cal span2 in units
34-35	SPAN3 mV/V	2	cal span3 in mV/V
36-37	SPAN3 units	2	cal span3 in units
38-39	SPAN4 mV/V	2	cal span4 in mV/V
40-41	SPAN4 units	2	cal span4 in units
42-43	SPAN5 mV/V	2	cal span5 in mV/V
44-43	SPAN5 units	2	cal span5 in units
46-47	SPAN6 mV/V	2	cal span6 in mV/V
48-49	SPAN6 units	2	cal span6 in units
50-51	SPAN7 mV/V	2	cal span7 in mV/V
52-53	SPAN7 units	2	cal span7 in units
54-55	SPAN8 mV/V	2	cal span8 in mV/V
56-57	SPAN8 units	2	cal span8 in units
58-59	SPAN9 mV/V	2	cal span9 in mV/V
60-61	SPAN9 units	2	cal span9 in units
62-63	SPAN10 mV/V	2	cal span10 in mV/V
64-65	SPAN10 units	2	cal span10 in units
66	# of SPAN POINTS	1	0 - 10 (0 if no eng cal)
67	CAL TYPE	1	0 = QUICK, 1 = DEADLOAD, 2 = KEYPAD
68	ENG UNITS	1	0 = LB, 1 = KG, 2 = TN, 3 = OZ, 4 = GM
69-70	CAPACITY	2	sum of rated capacity of load
71	DECIMAL POINT	1	0 - 6 decimal point position: 0= none, 3= 0.000
72-73	RATED OUTPUT mV/V	2	average of load cells rated output in mV/V
74	UNIT COUNT BY	1	0 - 6 = 1,2,5,10,20,50,100
75	ZERO LIMIT	2	keypad push to zero limit
77-78	OVERLOAD	2	overload limit, 0 = no limit
79	LEVEL CONFIG	1	level bargraph configuration: 0 = off/gross, 1 = on/gross, 2 = off/net, 3 = on/net 4 = off rate, 5 = on rate
80-81	LEVEL 0%	2	level 0% setting
82-83	LEVEL 100%	2	level 100% setting
84	ARROWS CONFIG	1	side arrows configuration: 0 = off/gross, 1 = on/gross, 2 = off/net, 3 = on/net 4 = off rate, 5 = on rate
85-86	ARROWS 0%	2	arrows 0% setting
87-88	ARROWS 100%	2	arrows 100% setting

Table 2.1. Continued

89	A1 ANNUNCIATOR	1	0 - 14: 0 = off	8 = d/a fault
90	A2 ANNUNCIATOR	1	1 = in motion	9 = d/a over
91	A3 ANNUNCIATOR	1	2 = zero lim	10 = d/a under
92	A4 ANNUNCIATOR	1	3 = overload	11 = rio status (green led)
93	A5 ANNUNCIATOR	1	4 = ser1 rx	12 = modem rx
94	A6 ANNUNCIATOR	1	5 = ser1 tx	13 = modem tx
95	A7 ANNUNCIATOR	1	6 = s1 par err	14 = setpoint output
96	A8 ANNUNCIATOR	1	7 = s1 fram err	
97	ZERO KEY CONFIG	1	0 = auto, 1 = manual	
98	TARE KEY CONFIG	1	0 = auto, 1 = manual	
99	ANALOG CONFIG	1	0 = gross, 1 = net	
100-101	ANALOG LOW	2	low analog output weight setting	
102-102	ANALOG HIGH	2	high analog output weight setting	
104-105	ANALOG LOW ADJ	2	low analog output adjustment	
106-107	ANALOG HIGH ADJ	2	high analog output adjustment	
108	FILTER AVERAGING	1	0-7 = 1,2,4,8,16,32,64,128 conversions	
109	FILTER BAND	1	0-10 = 0-2.5 counts, 11-108 = 3-100 counts	
110	MOTION	1	0 = off, 1-10 = 0-2.5 counts, 11-58 = 3-50 counts	
111	MOTION TIMER	1	0 - 3 = 0.5, 1.0, 1.5, 2.0 seconds	
112-115	PASSWORD	4	allowable ASCII chars are 0-9,A-Z, minus, space. word 112 low byte is first char, word 115 low byte is last char, word 115 high byte set to 0	
116	KEY/SECURITY LOCKS	1	bits 0-4 = zero,tare,g/n,print,edit keys bit 5 = security lock 0 = off, 1 = on	
117	MENU LOCKS	1	bits 0-4 = cal,filter,display,i/o,diag, menus bit 5 = rate menu (LCp-200): 0 = off, 1 = on	
118	SERIAL 1 FORMAT	1	0 = print, 1 = continuous, 2 = pc, 3 = MODBUS, 4 = Provox	
119	SERIAL 1 ADDRESS	1	0 - 99	
120	SERIAL 1 BAUD RATE	1	0 = 9600, 1 = 19200, 2 = 300, 3 = 600, 4 = 1200, 5 = 2400, 6 = 4800	
121	SERIAL 1 PARITY	1	0 = none, 1 = even, 2 = odd	
122	PRINT DATA SELECT	1	0 = no, 1 = yes bits 0-4 = display,gross,net,zero,tare data; bit 5 = rate	
123	PRINT DATA FORMAT	1	0 = no, 1 = yes bits 0-1 = stx,address bit 2 = leading 0s: 0 = spaces, 1 = zeros bit 4 = status bit 5 = delimiter 0 = space, 1 = crlf bit 6 = terminating character 0 = crlf, 1 = cr bits 7,3 = units 00 = no, 01 = abbreviated, 10 = expanded	
124	PRINT CRLF DELAY	1	0-99 = 0.0 - 9.9 seconds	
125	CON'T DATA SELECT	1	0 = no, 1 = yes bits 0-4 = display,gross,net,zero,tare data; bit 5 = rate	
126	CON'T DATA FORMAT	1	0 = no, 1 = yes bits 0-1 = stx,address bit 2 = leading 0s: 0 = spaces, 1 = zeros bit 3-4 = units,status bit 5 = delimiter 0 = space, 1 = crlf bit 6 = terminating character 0 = crlf, 1 = cr bit 7 = timer: 0/1 = no/yes	
127	CON'T TX TIMER	1	0-599 = 00.0 - 59.9 seconds	
128	CON'T TX TIMER	1	0-240 = 0 - 240 minutes	
129	TAG NUMBER	4	allowable ASCII chars are 0-9, A-Z, minus, and space. reg 129 low byte is first char, reg 132 low byte is last char, reg 132 high byte = 0	
133	CAL DATE	3	6 ASCII digits 0-9 starting from low byte of reg 133 to high byte of reg 135. format = MMDDYY month/day year of customer last calibration	

Table 2.1. Continued

136	NEXT CAL	3	6 ASCII digits 0-9 starting from low byte of reg 136 to high byte of reg 138. format = MMDDYY month/day year of customer next calibration
139	RIO BAUD RATE	1	0 = 57.6k, 1 = 115.2k, 2 = 230.4k
140	RIO RACK #	1	0-62 = 1-77 octal, 63 = 0
141	RIO QUARTER	1	0-3 = 1-4 starting quarter
142	RIO LAST RACK	1	0 = not last rack, 1 = last rack
143	INSTRUMENT	1	100 = LCp-100, 200 = LCp-200
144	OPTIONS	3	[M]-[A]-[P]-[C]-[B]-[M]: 6 ASCII digits starting with high byte of reg 40144 to low byte of reg 40146
147	RATE UNITS	1	rate units: 0 = unit/sec, 1 = unit/min
148	RATE RESOLUTION	1	rate resolution (0-12): 0 = highest, 12 = lowest
149	RATE DV TIME	1	rate derivation time = 1-1250 seconds
150	RATE MIN DV TIME	1	rate minimum derivation time = 1-1250 seconds
151	CURRENT RATE DATA	2	current rate data
153	DISPLAY POWERUP	1	display power-up: 0 = gr, 1 = nt, 2 = rate
154-169			spare
170	OUTPT 1 MAIN	2	output 1 main value
172	OUTPT 1 INFLIGHT	1	output 1 inflight
173	OUTPT 1 DEADBAND	1	output 1 deadband
174	OUTPT 1 CONFIG	1	output 1 configuration; bit 0 = main(0)/drib(1), bit 1 = track gross (0)/net(1), bit 2 = 0, bit 3 = on below (0)/above (1)
175	OUTPT 1 TAG	4	output 1 tag; 8 ASCII characters (space,1-0,'-',A-Z) starting with low byte of reg 175 to high byte of reg 178
179	OUTPT 2 MAIN/DRIB	2	output 2 main (or output 1 dribble) value
181	OUTPT 2 INFLIGHT	1	output 2 inflight
182	OUTPT 2 DEADBAND	1	output 2 deadband
183	OUTPT 2 CONFIG	1	output 2 config; see definition for output 1 config
184	OUTPT 2 TAG	4	output 2 tag; see definition for output 1 tag
188	OUTPT 3 MAIN/DRIB	2	output 3 main (or output 2 dribble) value
190	OUTPT 3 INFLIGHT	1	output 3 inflight
191	OUTPT 3 DEADBAND	1	output 3 deadband
192	OUTPT 3 CONFIG	1	output 3 config; see definition for output 1 config
193	OUTPT 3 TAG	4	output 3 tag; see definition for output 1 tag
197	OUTPT 4 MAIN/DRIB	2	output 4 main (or output 3 dribble) value
199	OUTPT 4 INFLIGHT	1	output 4 inflight
200	OUTPT 4 DEADBAND	1	output 4 deadband
201	OUTPT 4 CONFIG	1	output 4 config; see definition for output 1 config
202	OUTPT 4 TAG	4	output 4 tag; see definition for output 1 tag
206	OUTPT 5 MAIN/DRIB	2	output 5 main (or output 4 dribble) value
208	OUTPT 5 INFLIGHT	1	output 5 inflight
209	OUTPT 5 DEADBAND	1	output 5 deadband
210	OUTPT 5 CONFIG	1	output 5 config; see definition for output 1 config
211	OUTPT 5 TAG	4	output 5 tag; see definition for output 1 tag
215	OUTPT 6 MAIN/DRIB	2	output 6 main (or output 5 dribble) value
217	OUTPT 6 INFLIGHT	1	output 6 inflight
218	OUTPT 6 DEADBAND	1	output 6 deadband
219	OUTPT 6 CONFIG	1	output 6 config; see definition for output 1 config
220	OUTPT 6 TAG	4	output 6 tag; see definition for output 1 tag
224	OUTPT 7 MAIN/DRIB	2	output 7 main (or output 6 dribble) value
226	OUTPT 7 INFLIGHT	1	output 7 inflight
227	OUTPT 7 DEADBAND	1	output 7 deadband
228	OUTPT 7 CONFIG	1	output 7 config; see definition for output 1 config
229	OUTPT 7 TAG	4	output 7 tag; see definition for output 1 tag
233	OUTPT 8 MAIN/DRIB	2	output 8 main (or output 7 dribble) value
235	OUTPT 8 INFLIGHT	1	output 8 inflight
236	OUTPT 8 DEADBAND	1	output 8 deadband
237	OUTPT 8 CONFIG	1	output 8 config; see definition for output 1 config
238	OUTPT 8 TAG	4	output 8 tag; see definition for output 1 tag
242	SETPPOINT LOCKS	1	bits 0-7 = setpoints 1-8; 0= off, 1 = on

Table 2-2. Status Word Bit Definitions

STAT1 - STATUS REGISTER 1

BIT 0	- POWF_RUP
BIT 1	- UNABLE TO TARE/ZERO BECAUSE OF MOTION
BIT 2	- UNABLE TO ZERO BECAUSE OF LIMIT
BIT 3	- ND UNDERRANGE
BIT 4	- AID OVERRANGE
BIT 5	- ND CONNECT FAULT
BIT 6	- D/A UNDERRANGE
BIT 7	- D/A OVERRANGE
BIT 8	- 0/A OPEN CIRCUIT
BIT 9	- NO mV/V CAL
BIT 10	- NO ENGINEERING CAL
BIT 11	- NO TEMPERATURE COMPENSATION
BIT 12	- NO MANUAL ZERO
BIT 13	- NO MANUAL TARE
BIT 14	- EEPROM ERROR
BIT 15	- SPARE

STAT2 - STATUS REGISTER 2

BIT 0 -	
BIT 1 -	
BIT 2 -	
BIT 3 -	
BIT 4 -	
BIT 5 -	
BIT 6 -	
BIT 7 -	
BIT 8 -	
BIT 9 -	
BIT 10 -	
BIT 11 -	
BIT 12	- MOTION
BIT 13	- TARE OR ZERO JUST ACQUIRED
BIT 14	- ZERO LIMIT
BIT 15	- OVERLOAD

SECTION 3. Definitions and Explanations

3.1 INPUT IMAGE TABLE BITS

A table is provided to explain the Input Image

Table presented in Figure 2-3. Table 3-1 defines

the bit structure of both input words.

Table 3-1. Input Image Table Word 'Bit' Definitions

Word 1	BITS 0 – 15	WEIGH DATA Signed integer.
Word 2	BITS 0 -7	<p>ABSOLUTE OVERFLOW DATA x 32768</p> <p>Word 2 bits 0-7 is absolute overflow data from word 1 used if weigh data is greater than 32,767. These 8 bits are combined with the word 1 integer in a floating point register by the following steps.</p> <ol style="list-style-type: none"> 1. Do a Masked move of Word 2 bits 0 - 7 to an integer register. 2. Multiply the integer register by 32768.0 and put the result in a floating point register. 3. Negate the floating point result if the word 1 integer is negative. 4. Add the word 1 integer to the floating point result.
	BIT 9 – 10	<p>DATA ID</p> <p>Identifies the data in word 1 and word 2 bits 0 - 5.</p>
	BIT 11	<p>SCAN ACKNOWLEDGE</p> <p>This bit is a copy of the same bit in the output image table. When the LCp receives the output image table data it copies this bit to the same location in the input image table. The plc can thus know if the remote i/o LCp has received the last write to the output image table.</p>
	BIT 12	<p>MOTION</p> <p>Is set if the weigh data is in motion as determined by the motion settings.</p>
	BIT 13	<p>FAULT</p> <p>Is set if there is a fault causing weigh data to be incorrect. This bit is cleared or suppressed by setting the clear fault bit in word 2 of the output image table.</p>
	BIT 14	<p>ZERO LIMIT</p> <p>Is set if current weight is equal to or greater than manual zero limit.</p>
	BIT 15	<p>OVERLOAD</p> <p>Is set if current weight is equal to or greater than overload limit.</p>

3.2 OUTPUT IMAGE TABLE BITS

Table 3-2 shows the structure and bit definition of each Output Image Table word. Reference Figure 2-3 to view word breakouts.

Table 3-2. Output Image Table Word/Bit Definitions

Word 1			
	BITS 0-15	NOT USED BY LCp	
Word 2			
	BIT 0	ZERO	If this bit changes from 0 to 1 the LCp will zero the gross weight if not currently in "motion" as determined by the motion status bit or if not outside the selectable zero limit. If not successful, bit (1) UNABLE TO TARE/ZERO BECAUSE OF MOTION or bit (2) UNABLE TO ZERO BECAUSE OF LIMIT in STATUS reg (10) of the block transfer registers will be set causing the fault bit (bit 13 of word 2 of the input image table) to be set.
	BIT 1	TARE	If this bit changes from 0 to 1 the LCp will tare the net weight if not currently in "motion" as determined by the motion status bit. If not successful, bit (1) UNABLE TO TARE/ZERO BECAUSE OF MOTION in STATUS rag (10) of the block transfer registers will be set causing the fault bit (bit 13 of word 2 of the input image table) to be set.
	BIT 2	PRINT	If this bit changes from 0 to 1 the LCp will transmit data in the transmit buffer if the serial port is configured for PRINT
	BIT 3-7	SPARE	
	BIT 8-10	DATA REQUEST	Requests data to be returned by LCp in word 1 and word 2 bits 0-7 of the input image table.
	BIT 11	SCAN ACKNOWLEDGE	This bit is set or reset by the plc to achieve data transfer synchronization between the plc's program scan and the remote I10 scan. When the LCp receives the output image table data it copies this bit to the same location in the input image table. The plc can thus know if the remote i/o LCp has received the last write to the output image table.
	BIT 12	SPARE	
	BIT 13	CLEAR FAULT	Setting this bit will clear all fault bits in the status register (10). If the a/d over/under-range or connect faults persist, the corresponding fault flags will be set again when this bit returns to 0.
	BIT 14-15	SPARE	

SECTION 4. Troubleshooting

4.1 GENERAL

This chapter presents troubleshooting tips for the Allen-Bradley Remote I/O Interface. For instrument related problems, see the appropriate BLH operator's manual.

4.1.1 REAR PANEL STATUS LED

A green LED located on the instrument rear panel (Figure 4-1) constantly displays the operating status of the RIO interface. The LED displays three conditions, failure, partial failure, and correct operation. These three states are defined in Table 4-1.

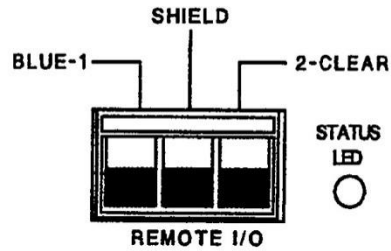

Figure 4-1. Status LED Indicator on Rear Panel

4.1.2 FRONT PANEL STATUS DISPLAY

The rear panel LED status indication can be displayed on the LCp-100/200 front panel by configuring one of the eight annunciators for Allen-Bradley Remote I/O status (see LCp-100/200 operators manual Figure 5-2).

Table 4-1. LED Status Indicator Explanation

LED Indicator Status	Error Condition	Check For
LED is OFF	No communication established	RIO option installed in LCp unit Power connection all units Matching baud rates/parameters Cable termination Cable short/open
LED is pulsing at 2 Hz	Partial communication established	Call BLH Field Service
LED is ON constantly	Full communication established	No problems

Appendix A
Outline and Wiring Drawings

Customer Wiring
LCp-100 Outline

Page A-2
Page A-3

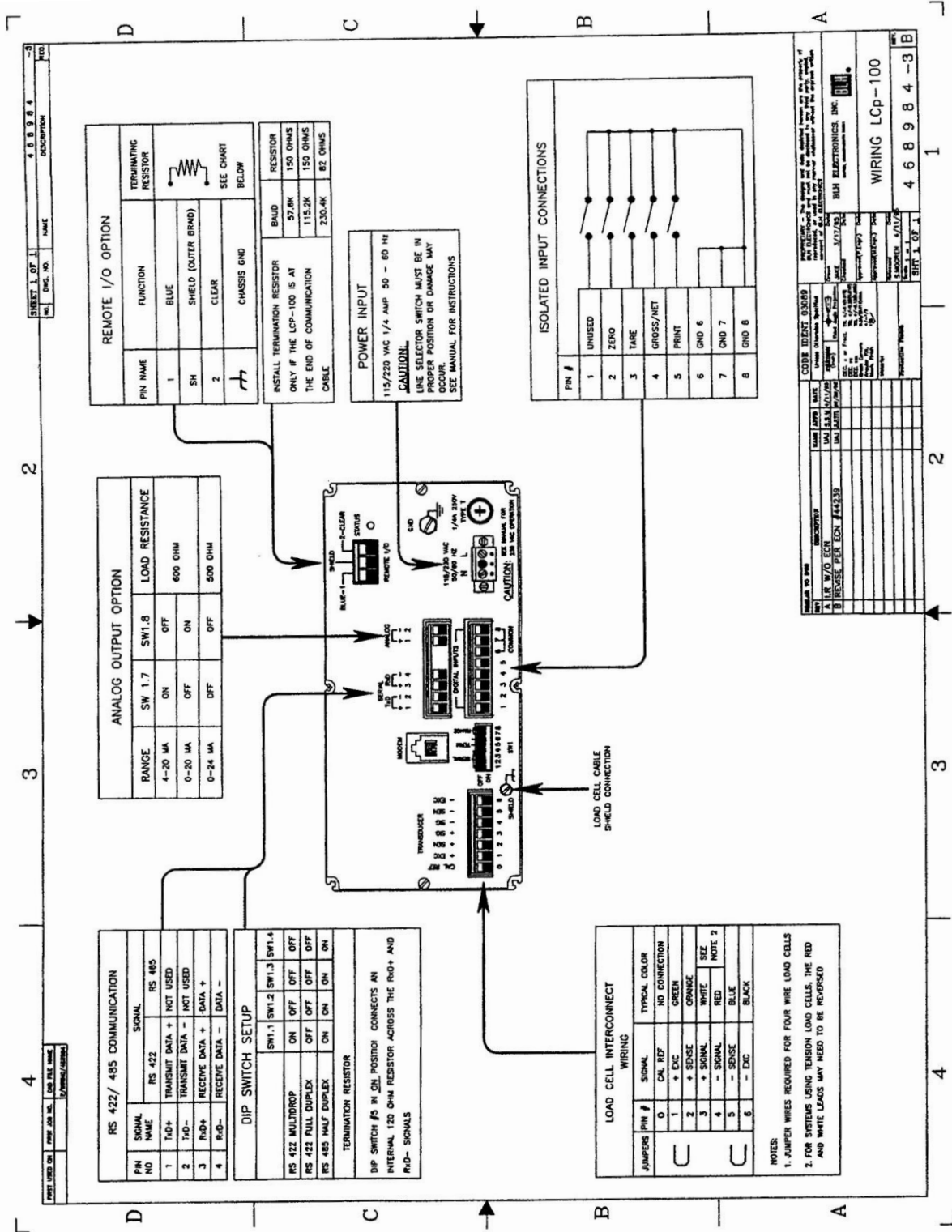

REV	DATE	DESCRIPTION
1	10/10/83	REVISED FOR LCP-100
2	10/10/83	REVISED FOR LCP-100
3	10/10/83	REVISED FOR LCP-100

BLM ELECTRONICS, INC.
WIRING LCP-100
4 6 8 9 8 4 -3 B

Appendix A-2

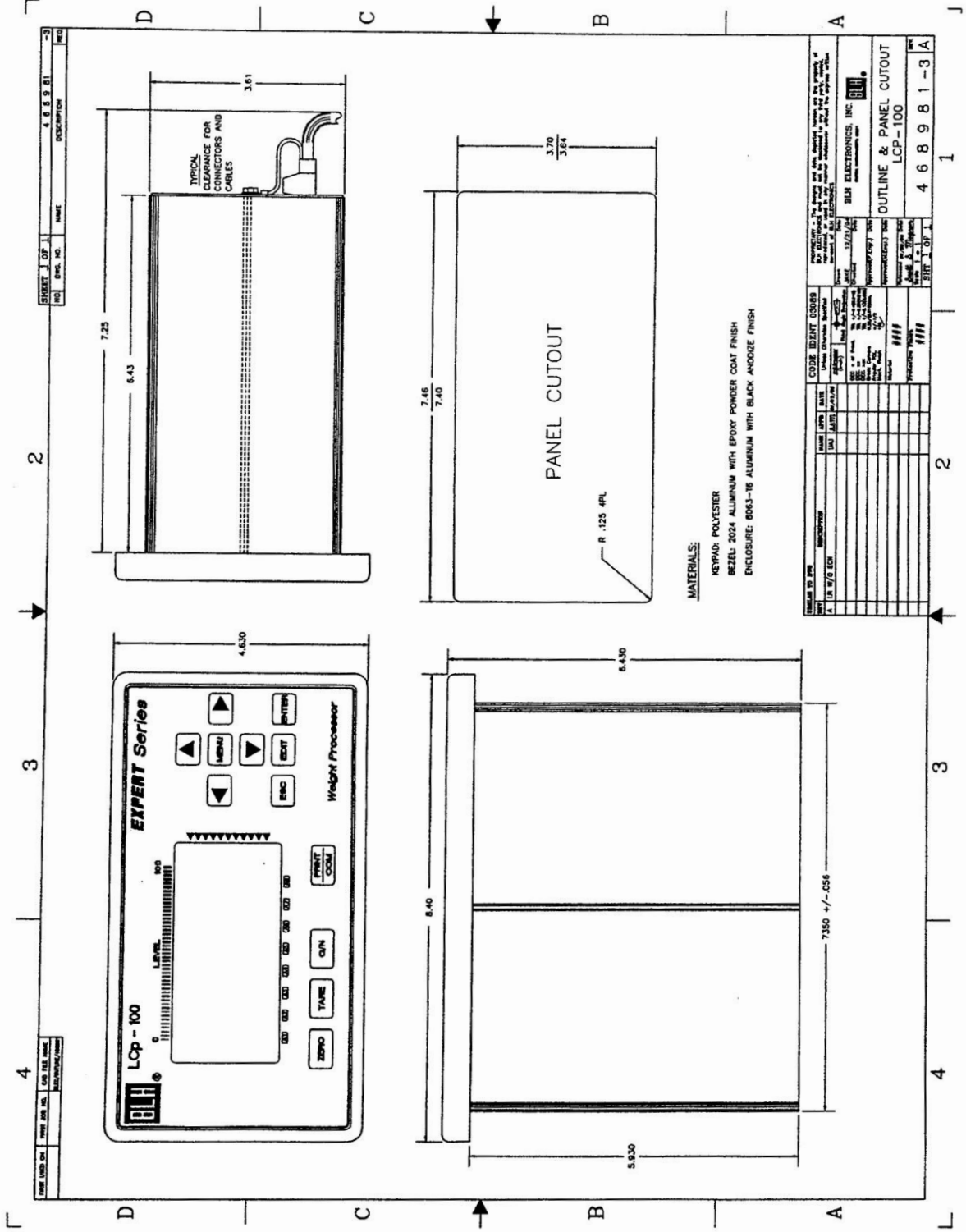

REV	DATE	BY	CHKD	DESCRIPTION
1	4 8 8 9 8 1			

CODE	IDENT	QTY	UNIT	REMARKS
1	1	1	1	1
2	2	2	2	2
3	3	3	3	3
4	4	4	4	4
5	5	5	5	5
6	6	6	6	6
7	7	7	7	7
8	8	8	8	8
9	9	9	9	9
10	10	10	10	10
11	11	11	11	11
12	12	12	12	12
13	13	13	13	13
14	14	14	14	14
15	15	15	15	15
16	16	16	16	16
17	17	17	17	17
18	18	18	18	18
19	19	19	19	19
20	20	20	20	20
21	21	21	21	21
22	22	22	22	22
23	23	23	23	23
24	24	24	24	24
25	25	25	25	25
26	26	26	26	26
27	27	27	27	27
28	28	28	28	28
29	29	29	29	29
30	30	30	30	30
31	31	31	31	31
32	32	32	32	32
33	33	33	33	33
34	34	34	34	34
35	35	35	35	35
36	36	36	36	36
37	37	37	37	37
38	38	38	38	38
39	39	39	39	39
40	40	40	40	40
41	41	41	41	41
42	42	42	42	42
43	43	43	43	43
44	44	44	44	44
45	45	45	45	45
46	46	46	46	46
47	47	47	47	47
48	48	48	48	48
49	49	49	49	49
50	50	50	50	50
51	51	51	51	51
52	52	52	52	52
53	53	53	53	53
54	54	54	54	54
55	55	55	55	55
56	56	56	56	56
57	57	57	57	57
58	58	58	58	58
59	59	59	59	59
60	60	60	60	60
61	61	61	61	61
62	62	62	62	62
63	63	63	63	63
64	64	64	64	64
65	65	65	65	65
66	66	66	66	66
67	67	67	67	67
68	68	68	68	68
69	69	69	69	69
70	70	70	70	70
71	71	71	71	71
72	72	72	72	72
73	73	73	73	73
74	74	74	74	74
75	75	75	75	75
76	76	76	76	76
77	77	77	77	77
78	78	78	78	78
79	79	79	79	79
80	80	80	80	80
81	81	81	81	81
82	82	82	82	82
83	83	83	83	83
84	84	84	84	84
85	85	85	85	85
86	86	86	86	86
87	87	87	87	87
88	88	88	88	88
89	89	89	89	89
90	90	90	90	90
91	91	91	91	91
92	92	92	92	92
93	93	93	93	93
94	94	94	94	94
95	95	95	95	95
96	96	96	96	96
97	97	97	97	97
98	98	98	98	98
99	99	99	99	99
100	100	100	100	100

Appendix A-3



BLH

3 Edgewater Drive,
Norwood, MA 02062 U.S.A
Phone (781)298-2200
Fax (781)762-3988
www.vishaypg.com