



BLH

**GLT Web Tension Transducer
Installation Instructions**

TM051
RevB
6/1/11
Doc 35129

Table of Contents

1	1-1
SECTION 1. General Information	1-1
1.1 INTRODUCTION.....	1-1
1.2 SPECIFICATIONS	1-1
1.3 WARRANTY POLICY	1-1
1.4 FIELD ENGINEERING.....	1-2
2 Installation	2-1
2.1 INTRODUCTION.....	2-1
2.2 PREPARATION FOR INSTALLATION	2-1
2.3 FRAME BASED INSTALLATION.....	2-4
2.4 OPTIONAL PILLOW BLOCK BASED INSTALLATION	2-4
2.5 ROLL AND DEAD SHAFT INSTALLATION.....	2-4
2.6 ELECTRICAL INSTALLATION	2-4
3 Calibration and Maintenance	3-1
3.1 CALIBRATION	3-1
3.2 MAINTENANCE	3-1
3.3 TROUBLE SHOOTING	3-1
4 Operation.....	4-1
4.1 TEMPERATURE CONSIDERATIONS	4-1
4.2 LOAD CONSIDERATIONS	4-1
4.3 INTRINSIC SAFETY	4-1

NOTICE

BLH makes no representation or warranties of any kind whatsoever with respect to the contents hereof and specifically disclaims any implied warranties or merchantability or fitness for any particular purpose. BLH shall not be held liable for errors contained herein or for incidental or consequential damages in connection with the furnishing, performance, or use of this publication or its contents.

BLH reserves the right to revise this manual at any time and to make changes in the contents hereof without obligation to notify any person of such revision or changes.

Call (781) 298-2216 for BLH Field Service

SECTION 1. General Information

1.1 INTRODUCTION

GLT transducers (Figure 1-1) provide precision accuracy and repeatability for low force web tension applications with a wide range of operating tensions, a small wrap angle, or a high roller weight to tension force ratio. Factory calibration, with closely matched output signals, eliminates field calibration and costly recalibration after the initial setup. Zero and span settings remain stable for tension forces operating at the low end of wide rangeability applications. Scribe marks allow for quick alignment of the GLT with the resultant tension force. Mounting configurations can be supplied for dead shaft roller assemblies.

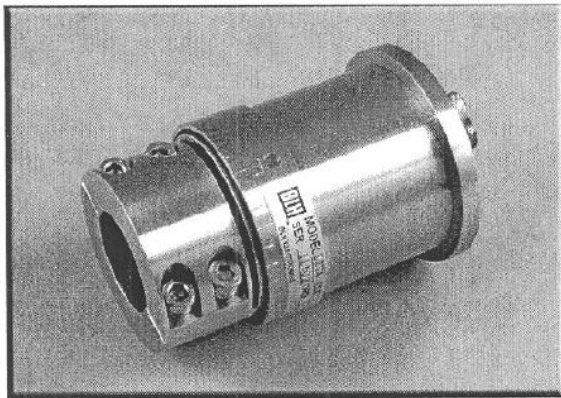

Figure 1-1. GLT Web Tension Transducer.

GLT series transducers for low force web tension applications use a differential bending beam transducer with a full Wheatstone Bridge for excellent stability, temperature, and performance specifications. Transducers are constructed of stainless steel for durability in corrosive environments.

Each unit can be rotated to measure the resultant tension force, not just a component of the force. The full bridge electrical output of each unit is calibrated within a tolerance of better than 0.25%. When coupled with BLI-1 instrumentation, system calibration can be accomplished without using dead weights or other sources of known force. Factory calibration, with closely matched output signals, eliminates field calibration and costly recalibration after the initial setup. Zero and span settings also remain stable for tension forces operating at the low end of wide rangeability applications.

1.2 SPECIFICATIONS

Rated Capacity	
GLT Capacity Range	20, 50, 100, 200, and 500 lb
Performance (% Rated Output)	
Rated Output (RO), nom.	2.000 mV/V +/-0.25%
Nonlinearity	0.25%
Hysteresis	0.10%
Repeatability	0.02% RO
Creep (20 Minutes)	0.05% RO
Zero Balance	5.0% RO
Electrical	
Input Resistance	350 ohms +/-3 ohms
Output Resistance	350 ohms +/-3 ohms
Insulation Resistance	< 5000 megohms
Recommended Excitation	10 Vac/dc
Maximum Excitation	18 Vac/dc
Electrical Connector	Bendix - PT-01-8-4P with mating half - PT06E-8-4S (SR)
Approvals	
FM (Factory Mutual)	3611 (Class I, II, III; Div.1,2; Groups A-G)
CSA	C22.2 (Class I, II, III; Div.1,2; Groups A-G)
Temperature	
Operating Range	-40 to 220°F (-40 to 105°C)
Compensated Range	+30 to 130°F (-1 to 54°C)
Effect on Zero Balance	0.0050% RO/°F
Effect on Rated Output	0.0050% of reading/°F
Overload Rating	
Safe Load	200% Rated Capacity
Ultimate Load	500% Rated Capacity
Safe Side Load	100% Rated Capacity
Materials	
All Capacities	15-5 PH Stainless Steel
Deflection at Rated Capacity	
All Capacities	0.003 - 0.020 inches
Sealing	
All Capacities	IEC IP65

NOTE: Shaft coupling spherical tilt capability = 3° max

NOTE: Intrinsically safe systems must be installed in accordance with Thermo BLH Drawing # 468872-2

1.3 WARRANTY POLICY

BLH warrants the products covered hereby to be free from defects in material and workmanship. BLH's liability under this guarantee shall be limited to repairing or furnishing parts to replace, f.o.b. point of manufacture, any parts which, within three (3) years from date of shipment of said product(s) from BLH's plant, fail because of defective workmanship or material performed or furnished by BLH. As a condition hereof, such defects must be brought to BLH's attention for verification when first discovered, and the material or parts alleged to be defective shall be

returned to BLH if requested. BLH shall not be liable for transportation or installation charges, for expenses of Buyer for repairs or replacements or for any damages from delay or loss of use for other indirect or consequential damages of any kind. BLH may use improved designs of the parts to be replaced. This guarantee shall not apply to any material which shall have been repaired or altered outside of BLH's plant in anyway, so as in BLH's judgment, to affect its strength, performance, or reliability, 01 10 any defect due in any part to misuse, negligence, accident or any cause other than normal and reasonable use, nor shall it apply beyond their normal span of life to any materials whose normal span of life is shorter than the applicable period stated herein. In consideration of the forgoing guarantees, all implied warranties are waived by the Buyer, BLH does not guarantee quality of material or parts specified or furnished by Buyer, or by other parties designated by buyer, if not manufactured by BLH. If any modifications or repairs are made to this

equipment without prior factory approval, the above warranty can become null and void.

1.4 FIELD ENGINEERING

Authorized BLH Field Service Engineers are available around the world to install GLT based web tension measurement systems and/or train factory personnel to do so. The field service department at Thermo BLH is the most important tool to assure the best performance from your application. Field service phone numbers are listed below.

**Factory: (Main Number)
(781) 298-2000**

Midwest: (614) 476-6453

Southwest (281) 655-5041

**Canada: (416) 251-2554
or**

(800) 567-6098 in Canada

2 Installation

2.1 INTRODUCTION

Thermo BLH uses full Wheatstone Bridge, Strain Gage Technology to produce web tension transducers superior to any currently available. Model GLT Transducers support each end of a 'dead' roll shaft (non-rotating) and mount to any surface perpendicular to the roll axis. Two outline diagrams show conventional machine frame mounting (Figure 2-1, 4) and optional pillow block mounting (Figure 2-2, 5) dimensions. Please use these diagrams in conjunction with all installation instructions presented in this chapter.

NOTE: Each Model GLT is factory assembled and ready to install. Do not take the GLT Transducer apart or adjust any screws other

than those referred to in these instructions. Doing so will void the warranty and may cause unnecessary damage.

2.2 PREPARATION FOR INSTALLATION

Read these instructions thoroughly before beginning installation. The following should be readily available at the installation site:

1. Allen wrench — 3/16"
2. Equipment to lift the roller (if it is heavy) during installation.
3. Inclinator and protractor to measure the angles of the web path and to adjust the working position of the GLT.
4. Chalk line inscribing tool for marking vertical plumb line.

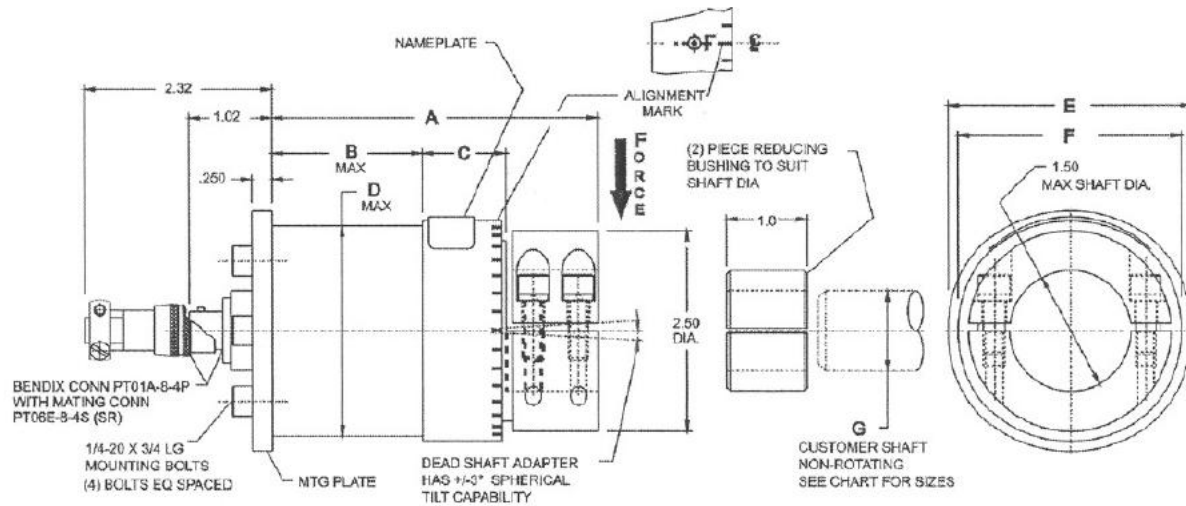

CAPACITY (lbs)	A	B	C	D Dia.	E Dia.	F	G Shaft Dia.
20/50/100	3.63	1.74	.87	2.375	2.75	2.50	1/2, 3/4, 1, 1 1/4 & 1 1/2
200/500	4.04	1.87	1.11	2.625	3.00	2.75	1, 1 1/4 & 1 1/2

CONNECTOR COLOR CODE		
EXCITATION	GREEN (+)	C
	BLACK (-)	B
OUTPUT	WHITE (+)	D
	RED (-)	A

Figure 2-1. GLT Frame Mount Outline Dimensions.

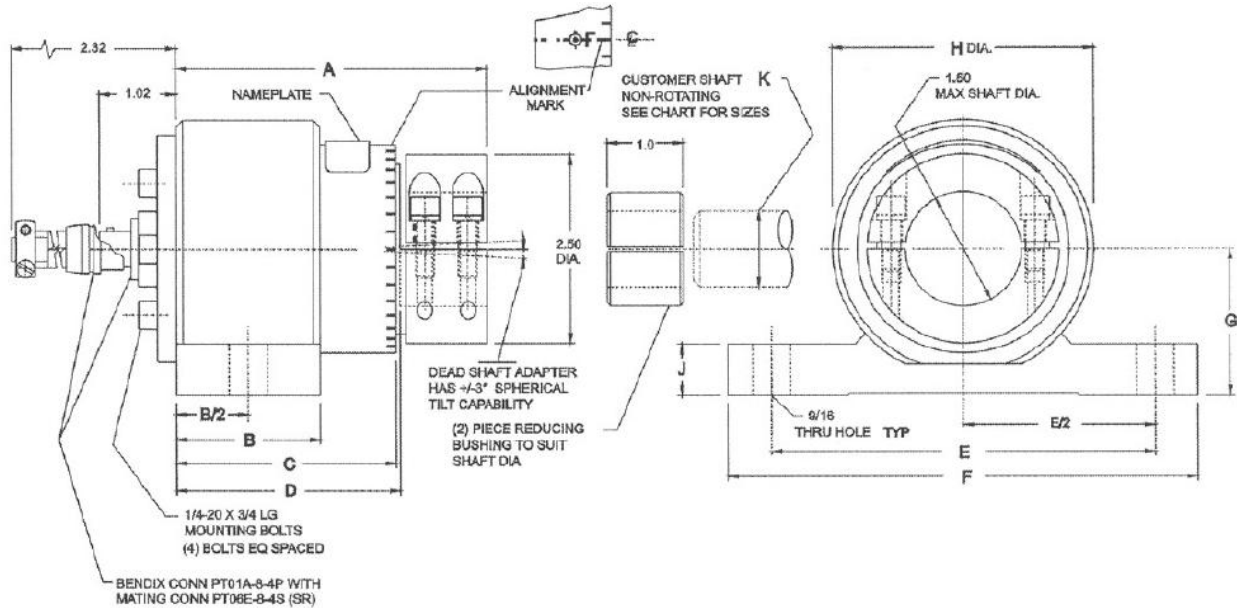

CONNECTOR COLOR CODE		
EXCITATION	GREEN (+)	C
	BLACK (-)	B
OUTPUT	WHITE (+)	D
	RED (-)	A

CAPACITY (lbs)	A	B	C	D	E	F	G	H	J	K DIA.
20/50/100	3.63	1.75	2.44	2.60	4.00	5.38	1.63	3.00	.58	1/2, 3/4, 1, 1 1/4 & 1 1/2
200/500	4.04	1.88	2.85	2.98	5.00	6.12	1.94	3.40	.68	1, 1 1/4 & 1 1/2

Figure 2-2. GET Pillow Block Mount Outline Dimensions (Optional)

Perform the following functions prior to mounting GLT transducers:

Determine the direction and angle of resultant web tension force FR (angle of inclination in Figure 2-3, following page). This is the angle to which the GLT Transducers will be rotated to intercept maximum web tension force. The web entry and exit angles, a and p (see Figure 2-3), should have been determined when the load cells were sized. Using the illustrations and formulas shown in Figure 2-3, calculate the resultant web tension force (FR). Jot this value down for use during installation. If entry and exit angle information is not available, use an inclinometer to measure the web entry and exit

angles ($\pm 1^\circ$) before dismantling the tension measurement shaft/roll.

Confirm that the distance between support points is correct. Total length between points should be equal to the length of the shaft plus dimension $C \times 2$ for frame mounting (Figure 2-1) or length of shaft plus dimension $(0 \text{ minus } B) \times 2$ for pillow block mounting (Figure 2-2).

Make a vertical plumb line on the machine frame, at each end, that coincides with the centerline of the roll. (This plumb line will be used as a reference to position the GLT transducers, rotationally, at the calculated angle of inclination).

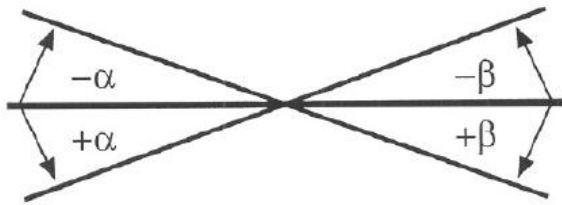

$$\gamma = \frac{-(\alpha) + (\beta)}{2} = \text{angle of inclination}$$

γ = Angle of Inclination
(from vertical)

α = web entry angle

β = web exit angle

+ = Clockwise

- = Counter Clockwise

F_R = Resultant Web Tension Force

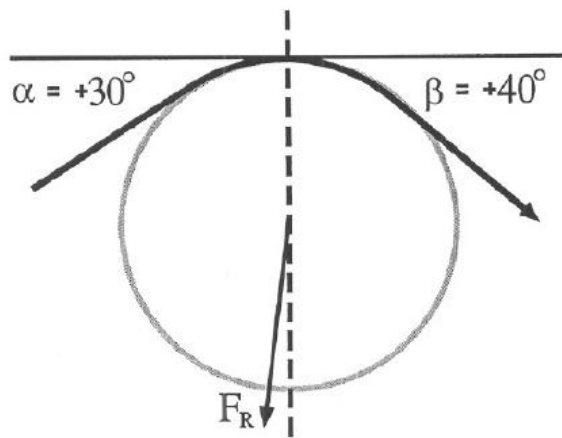

$$\gamma = \frac{-(30^\circ) + (40^\circ)}{2} = +5^\circ$$

$\gamma = +5^\circ$ (Clockwise from Vertical)

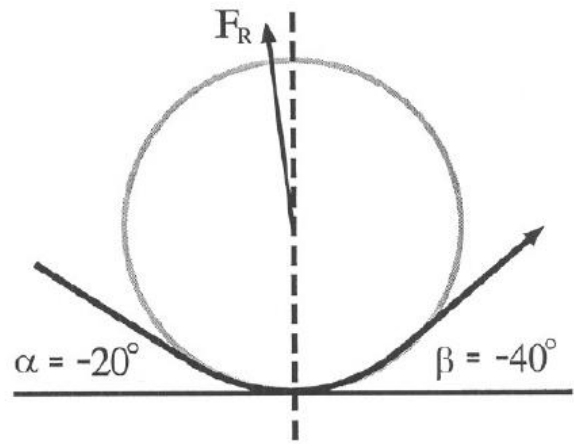

$$\gamma = \frac{-(-20^\circ) + (-40^\circ)}{2} = -10^\circ$$

$\gamma = -10^\circ$ (Counter Clockwise from Vertical)

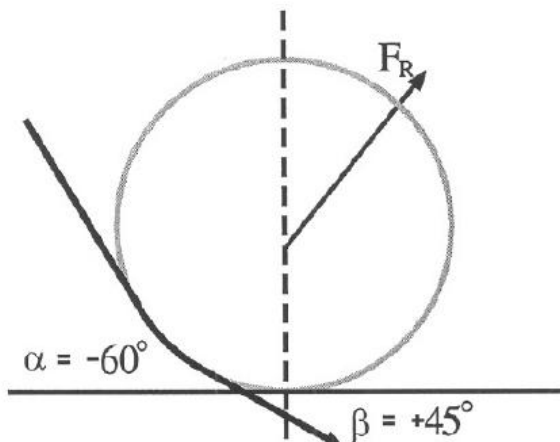

$$\gamma = \frac{-(-60^\circ) + (45^\circ)}{2} = +52.5^\circ$$

$\gamma = +52.5^\circ$ (Clockwise from Vertical)

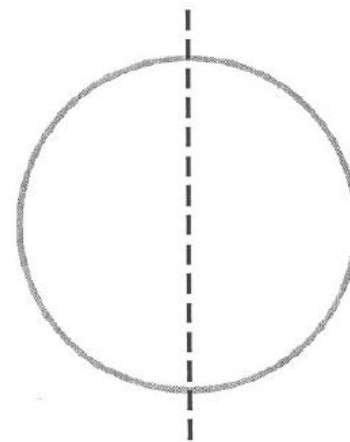

$$\gamma = \frac{-(\quad) + (\quad)}{2} =$$

γ = Your Calculation Here

Figure 2-3. Angle of Inclination Calculation

2.3 FRAME BASED INSTALLATION

Use Figure 2-4 as a guide in performing the following installation steps:

1. Prepare a clean, smooth surface on machine frame_
2. Drill hole in machine frame to Diameter "D" (Figure 2-1) allowing 0.01 inch for clearance.
3. Ensure that machine frame thickness is equal to dimension "B" or add spacer ring to make it so.
4. Remove four 1/4-20 socket head bolts and GLT Transducer mounting plate.
5. Slide the GLT Transducer through the hole in the machine frame.
6. Using GLT Transducer grid marks (each grid mark = 10') and scribed/chalked plumb line, rotate transducer to angle of inclination (angle F_R as calculated prior to installation).
7. Bolt mounting plate back on to transducer, tightening socket head bolts to 125 in/lb.

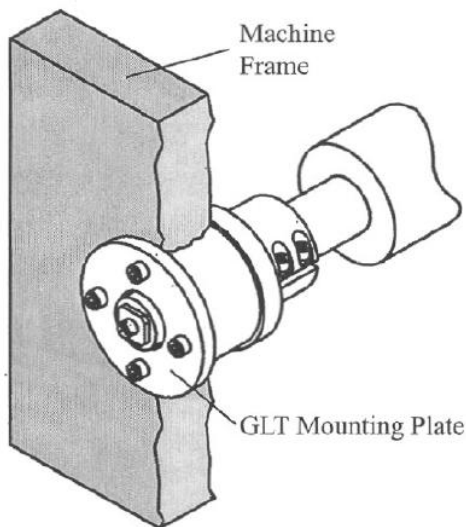

Figure 2-4. Frame Based Mounting Diagram

2.4 OPTIONAL PILLOW BLOCK BASED INSTALLATION

Use Figure 2-5 as a guide in performing the following installation steps:

1. Prepare clean, smooth surface on machine frame.
2. Drill two holes for pillow block mounting bolts (customer supplied)

according to dimension "E" (Figure 2-2). Pillow block through holes are 9/16 inch in diameter so bolts must be 1/2 inch, grade 2 or better.

3. Tighten pillow block mounting bolts to manufacturer's torque specification.
4. Loosen four 1/4-20 socket head bolts on transducer mounting plate.
5. Using GLT Transducer grid marks (each grid mark = 10") and scribed/chalked plumb line, rotate transducer to maximum tension angle (angle F_R as calculated prior to installation).
6. Tighten socket head bolts to 125 in/lb.

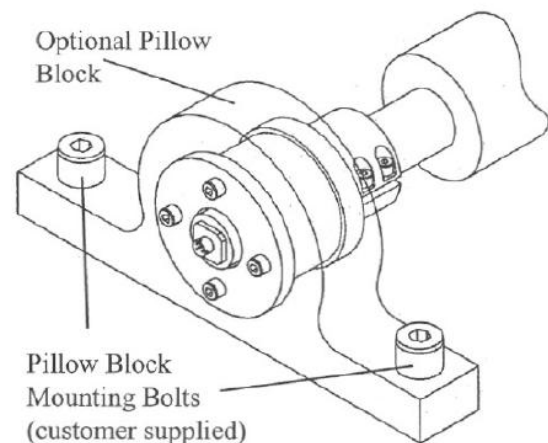

Figure 2-5. Pillow Block Mounting Diagram

2.5 ROLL AND DEAD SHAFT INSTALLATION

Use Figure 2-6 and the following instructions to finish mechanical installation by installing the roll and dead shaft.

1. Remove the Dead Shaft Adapter Upper Clamping Blocks from both GLT Transducers.
2. Place shaft ends in the Dead Shaft Adapter Lower Clamping Blocks.
3. Check to be sure that roll and shaft are level per manufacturer's specifications.
4. Replace the Upper Clamping Blocks and tighten the 1/4-20 Clamping Block Bolts to 125 inch/pounds.

Mechanical installation is now complete.

2.6 ELECTRICAL INSTALLATION

Each GLT Transducer is supplied with a Bendix connector and mating half. The connector pin

assignments and Bendix designations are shown in Figure 2-1 or 2-2 (identical). Cable is not supplied, but can be purchased as necessary. Use four conductor shielded cable consisting of two twisted pairs of 20 A.W.G. wire (one pair excitation, one pair signal output) to connect the GLT to a summing junction box or directly to the transmitter/indicator instrument, where provision is made for direct connection (see Figure 2-7 following page). The color code shown is for BLH four-conductor shielded cable (P/N 461979).

Recommended excitation voltage is 10 VDC. Maximum excitation voltage is 18 VDC. A regulated, precision power supply (supplied in all

Thermo BLH instrumentation) must be used. Since signal output levels are very low (2 mV/V full scale typical), small power supply changes will greatly affect the output. If the distance between the transducers and power supply is greater than 50 ft., a Model 304 Cable Extension Box or Model 306 Summing Junction Box (for two GLT's) is recommended.

Use six conductor shielded cable, consisting of three twisted pairs of 20 A.W.G. wire (BLHP/11 207078), to connect the Model 304 or 306 to the instrument. Note that the two extra lines are used for sensing the excitation voltage and regulating the power supply accordingly.

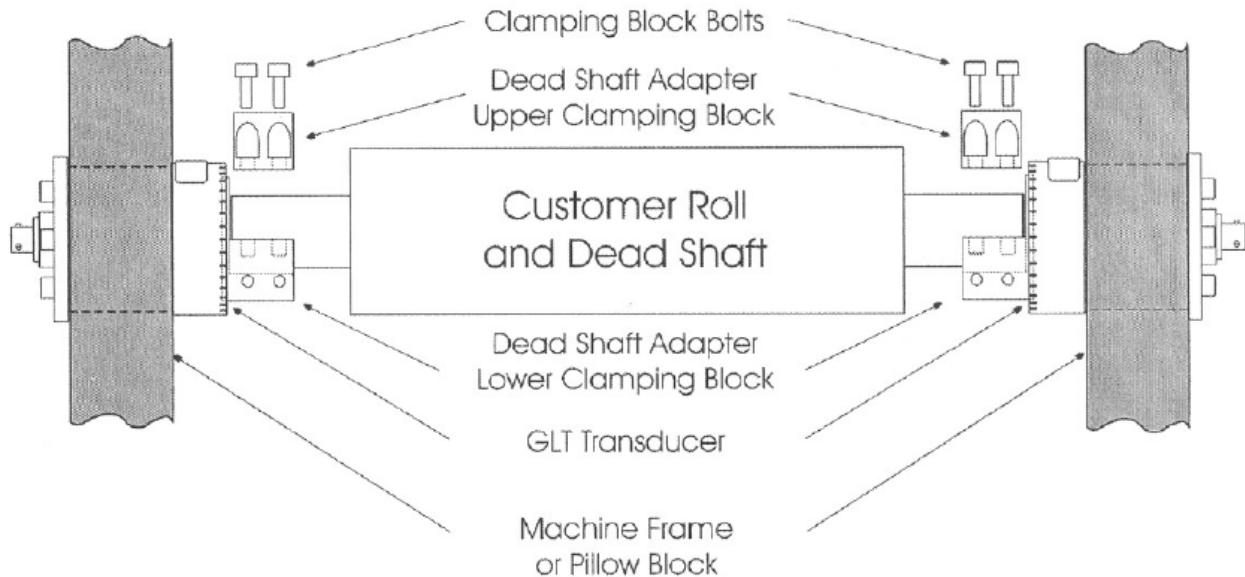

Figure 2-6. Roller and Shaft Installation Diagram.

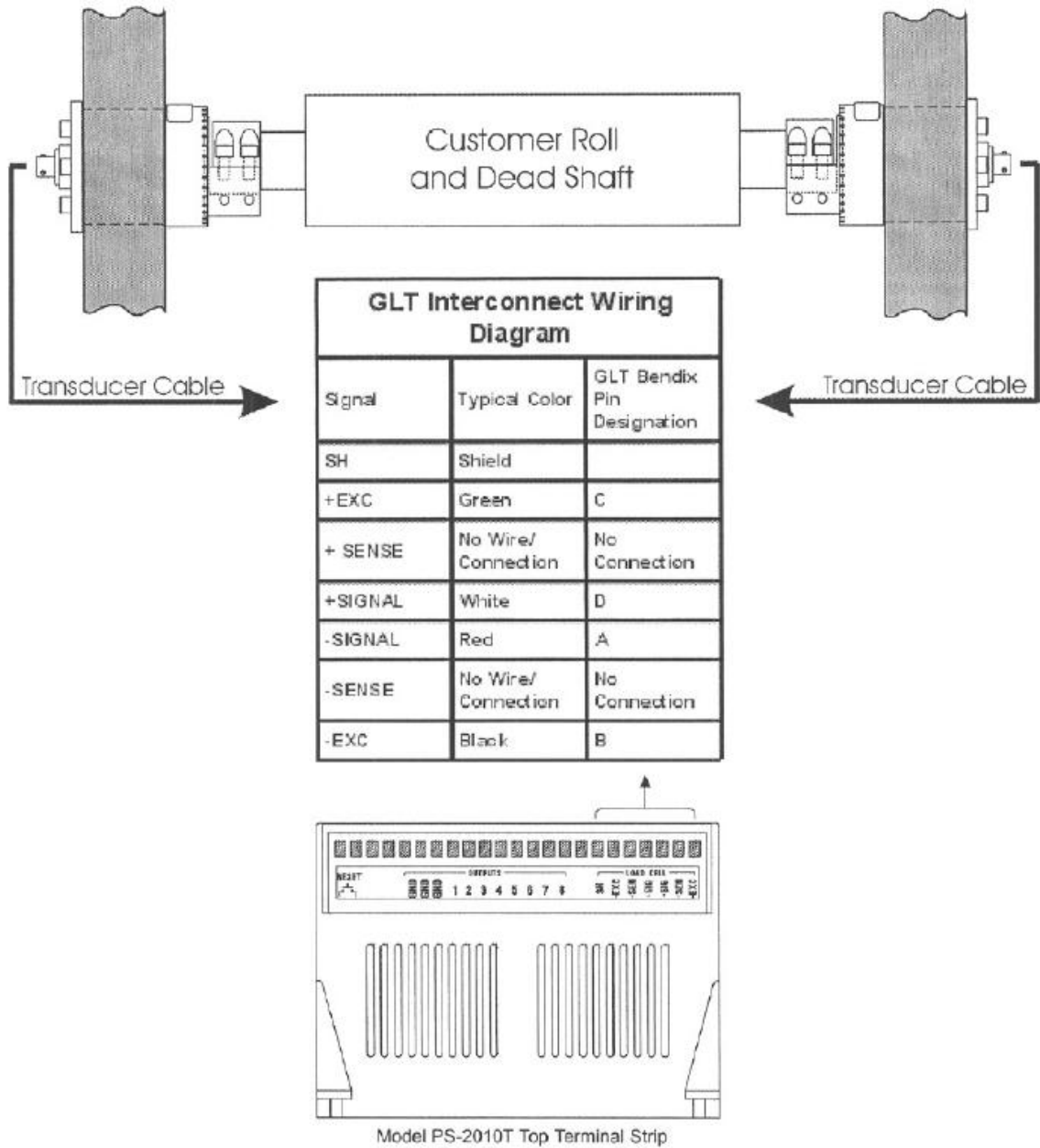

Figure 2-7. Typical GLT System Wiring Configuration.

3 Calibration and Maintenance

3.1 CALIBRATION

GLT transducers are carefully checked and calibrated at BLH before shipment. Accuracy of the instruments and standards used for calibration are traceable to the National Institute of Standards and Technology (NIST).

Calibration can be checked by applying the rated tension force to the module and comparing the output with original data on the calibration certificate. Calibration should be checked if the beam is thought to have been overloaded beyond its safe overload rating (200%). GLT transducers cannot be adjusted by the user and any transducer displaying calibration error should be returned to BLH for service.

To calibrate the GLT instrument/indicator, use instructions from the instrument/indicator operator's manual.

3.2 MAINTENANCE

GLT transducers typically require no maintenance.

3.3 TROUBLE SHOOTING

To determine if the GLT circuit is operative, apply 10 VDC to the input pins (see Figure 2-1). Connect a digital volt meter (DVM) to the output pins. Press gently (do not exceed GLT rated capacity) along the primary axis while watching the DVM. Normal readings should range from slightly above zero to 20 mV.

To determine the cause of incorrect operation of the measuring system, perform the following inspections:

- a. Check instrument power and fuses.
- b. Check that connections to the instrument are correct and tight.
- c. Check instrument performance independently following recommended procedure.
- d. Check continuity of interconnecting leads.
- e. Check junction box connections (where used).
- f. Check for proper excitation voltage.
- g. Insulation resistance checks: The GLT must be disconnected for leakage test (measured values should exceed 5000 M-ohms).
 - a. Ground to a lead of the interconnecting cable_
 - b. Module case to a lead of the cable.
 - c. Module case to the shield of the cable.
- h. Input/Output resistance check. Disconnect the module cable leads from the instrument or junction box. Measure the resistance between the input leads and between the output leads. Resistance should be as specified. OHMMETER USED SHOULD NOT APPLY MORE THAN 15 VOLTS TO THE BEAM BRIDGE.

Resistance readings other than those listed in the specifications indicate a failure within the unit. DO NOT attempt to repair; faulty transducers require factory service. Contact a local sales office or BLH directly for RETURN AUTHORIZATION. Upon examination of the module at the factory, a full report on the condition with a quotation on repair cost and delivery will be submitted to the customer.

4 Operation

4.1 TEMPERATURE CONSIDERATIONS

GLT transducers perform best when operated within their compensated temperature range of +30 to +130 degrees Fahrenheit.

Special precautions must be taken to ensure that actual transducer temperature is held within specified limits. These precautions are necessary whether or not the transducer is being operated.

4.2 LOAD CONSIDERATIONS

GLT transducers can be periodically (for optimal fatigue life under cyclic loading, do not exceed 100% full scale) loaded up to 200% of rated load without adverse effects.

CAUTION

A shock overload in excess of the Overload Rating may permanently affect the accuracy and performance of the transducer. Peak vibratory loadings should be limited to 100% of rated capacity to preclude premature fatigue failure of the transducer.

4.3 INTRINSIC SAFETY

GLT transducers can be installed in hazardous locations if the proper electronic precautions are taken. Consult the factory for installation instructions/diagrams.



3 Edgewater Drive
Norwood, MA 02062 USA
Phone (781) 298-2200
Fax (781) 762-3988

www.vishaypg.com