

AD623 vs. MAX4194

The AD623 has less noise...

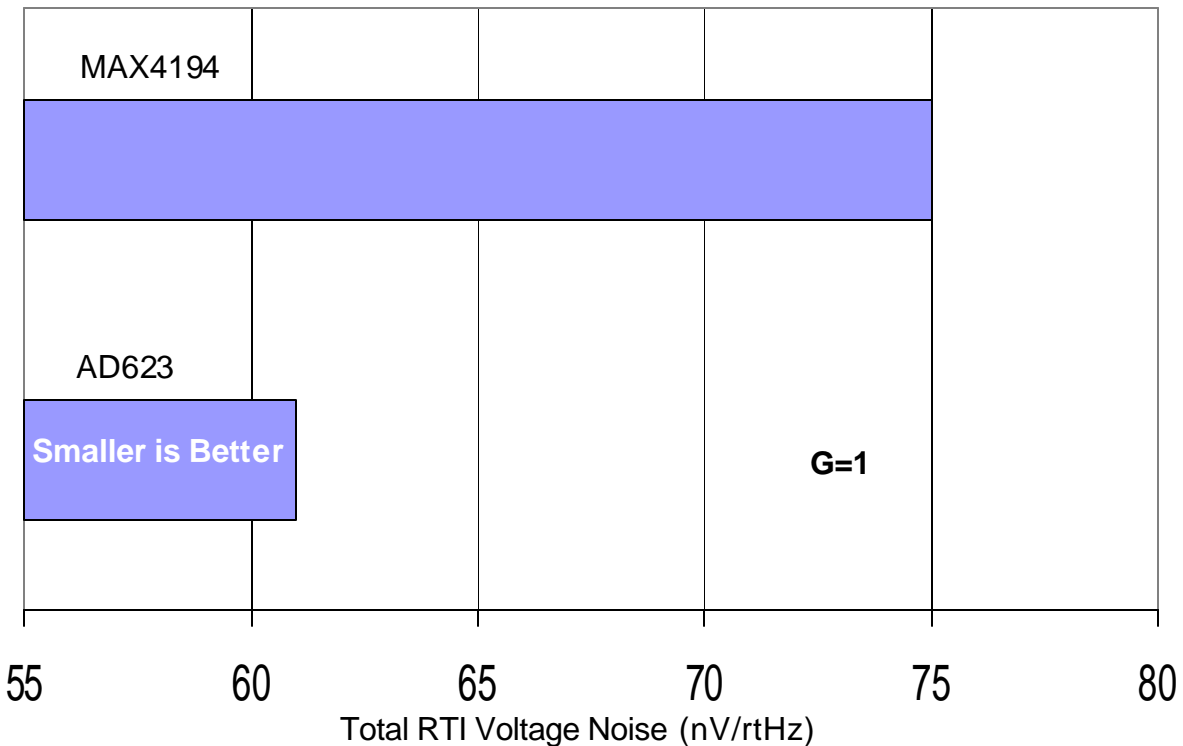

higher bandwidth...

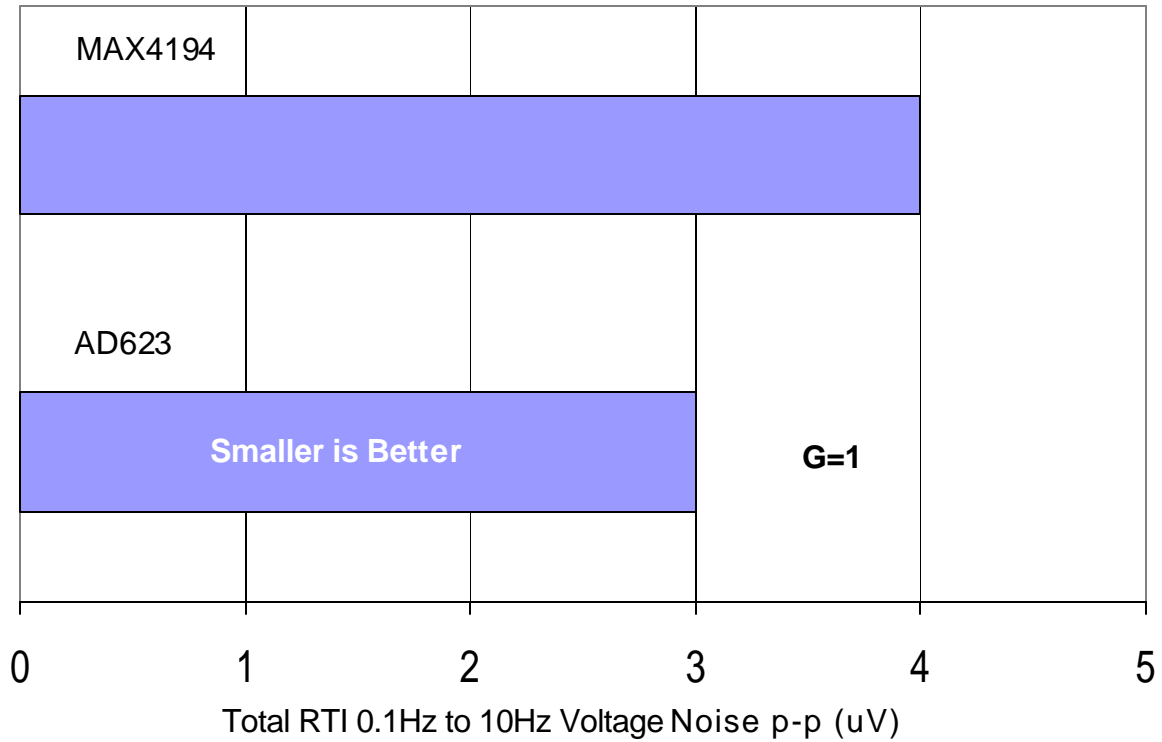
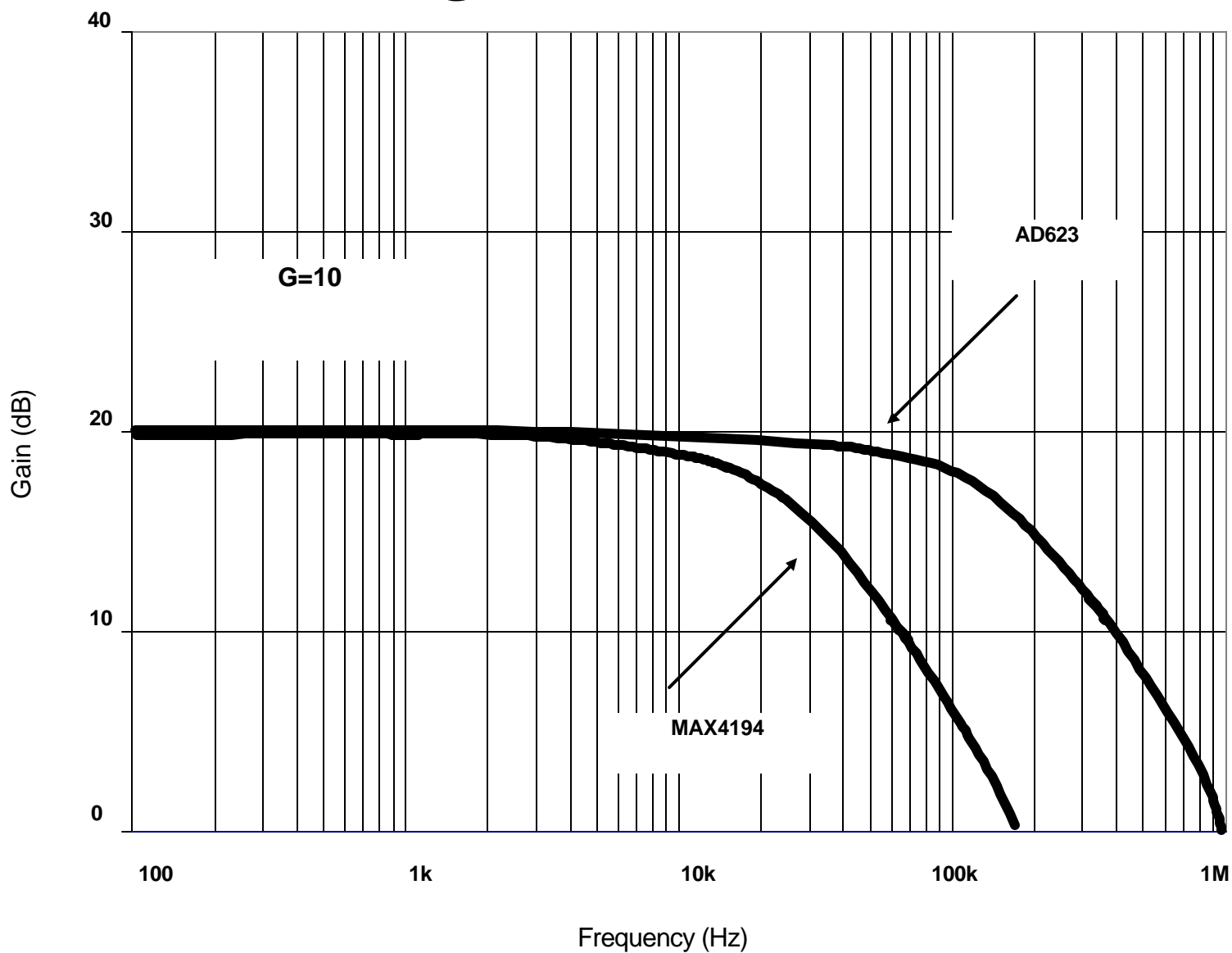

and contributes less error.

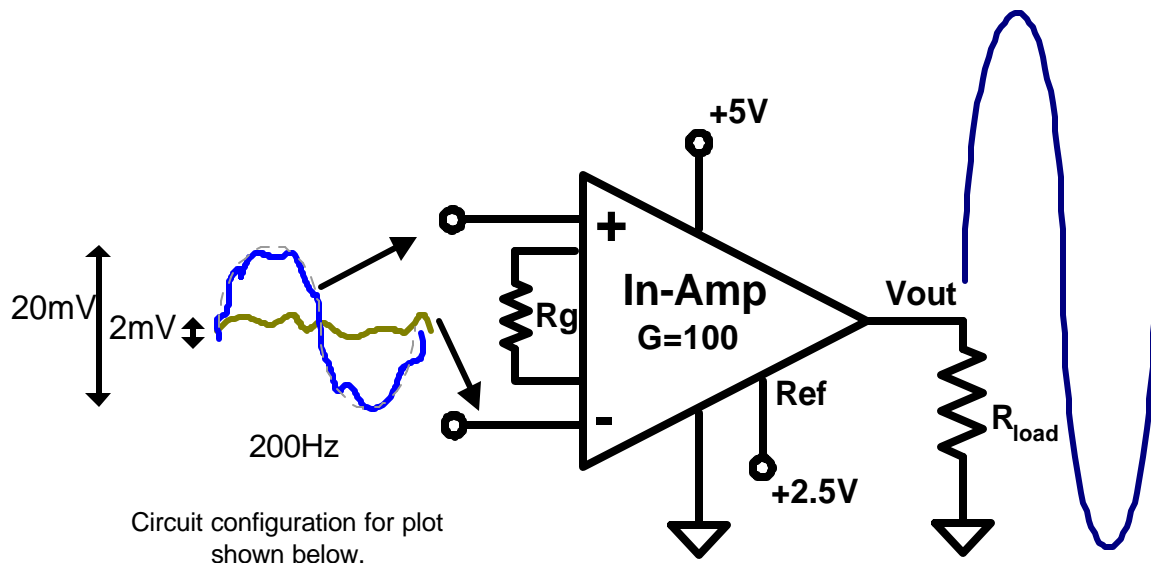

Accuracy Lost To Vos and Gain Error

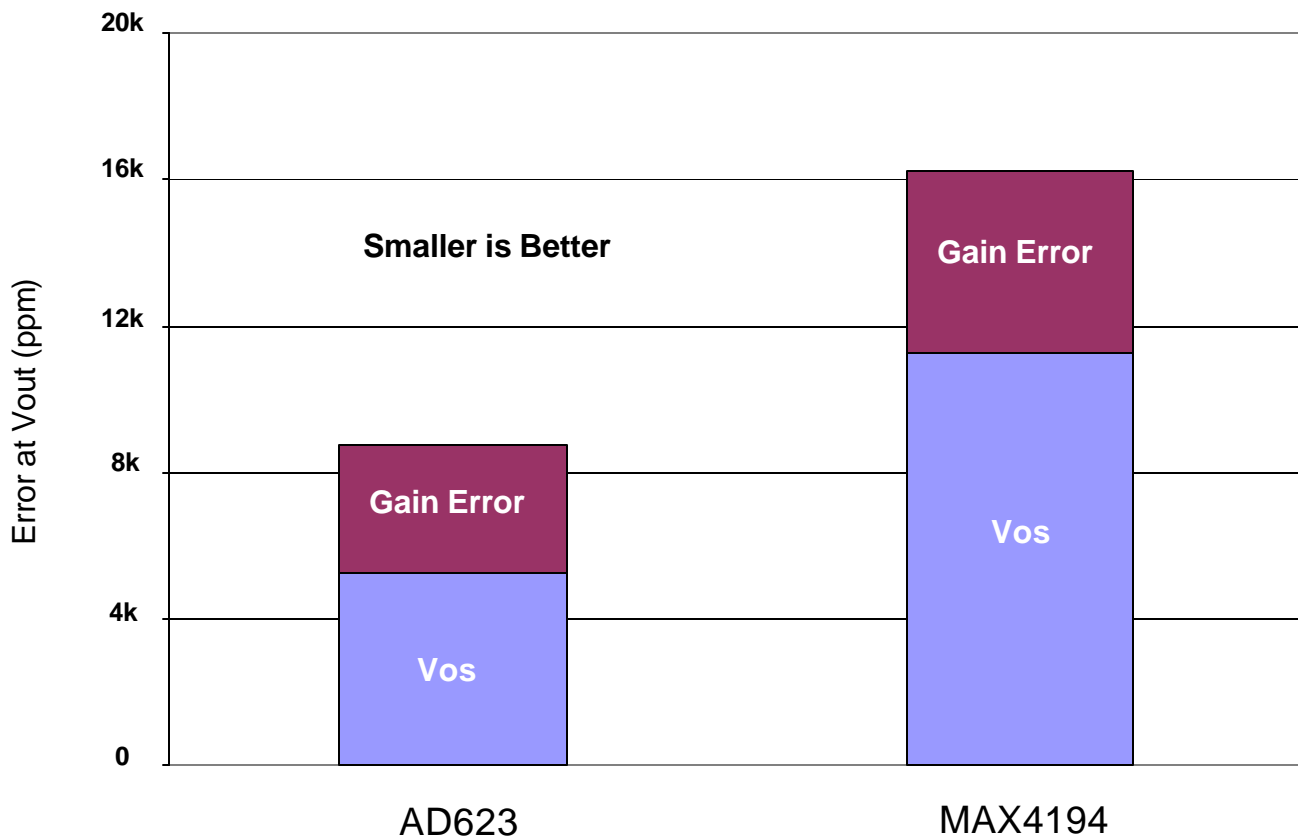

The AD623 is an excellent thermocouple amplifier.

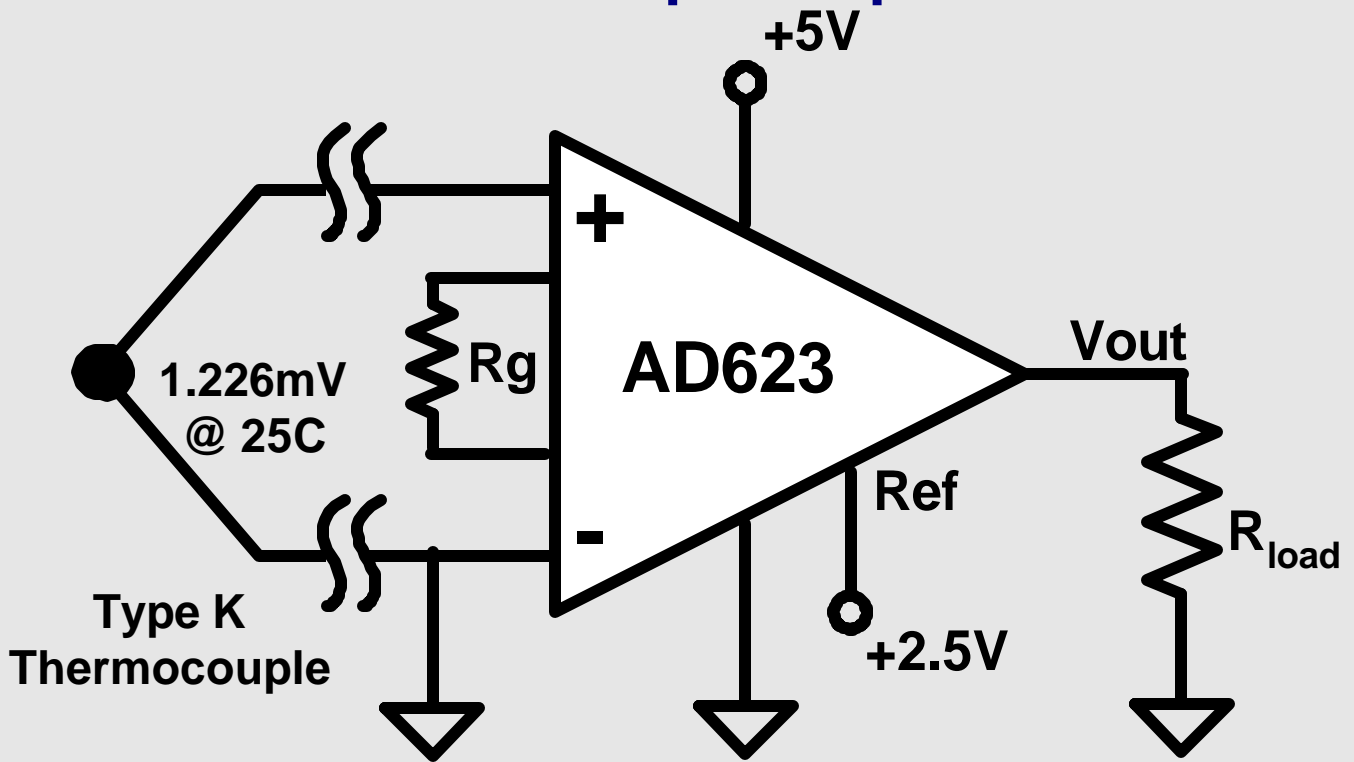

Useable common-mode voltage range extends to 0V even with a single supply.