

## Synchronous Buck PWM and Linear Controller

### Features

- Provide Two Regulated Voltages
  - Synchronous Rectified Buck PWM Controller
  - Linear Controller
- Fast Transient Response
  - 0~85% Duty Ratio
- Excellent Output Voltage Regulation
  - 0.8V Internal Reference
  - $\pm 1\%$  Over Line Voltage and Temperature
- Over Current Protection
  - Sense Low-Side MOSFET's  $R_{DS(ON)}$
- Under Voltage Lockout
- Small Converter Size
  - 250KHz Free-Running Oscillator
  - Programmable From 70kHz to 800kHz
- 14-Lead SOIC Package

### Applications

- Graphic Cards
- Memory Power Supplies
- DSL or Cable MODEMs
- Set Top Boxes
- Low-Voltage Distributed Power Supplies

### General Description

The APW7063 integrates PWM and linear controller, as well as the monitoring and protection functions into a single package. The synchronous PWM controller which drives dual N-channel MOSFETs, which provides one controlled power outputs with under-voltage and over-current protections. Linear controller drives an external N-channel MOSFET with under-voltage protection.

APW7063 provides excellent regulation for output load variation. An internal 0.8V temperature-compensated reference voltage is designed to meet the various low output voltage applications. APW7063 includes a 250kHz free-running triangle-wave oscillator that is adjustable from below 70KHz to over 800KHz.

A power-on-reset (POR) circuit limits the VCC minimum operating supply voltage to assure the controller working well. Over current protection is achieved by monitoring the voltage drop across the low side MOSFET, eliminating the need for a current sensing resistor and short circuit condition is detected through the FB pin. The over-current protection triggers the soft-start function until the fault events be removed, but Under-voltage protection will shutdown IC directly. Pull the COMP pin below 0.4V will shutdown the controller, and both gate drive signals will be low.

## Pinouts

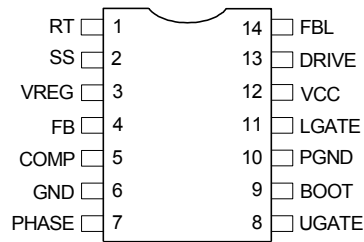

## Ordering and Marking Information

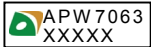
<p>APW 7063 □□-□□□</p> <ul style="list-style-type: none"> <li>□□□ : Lead Free Code</li> <li>□□ : Handling Code</li> <li>□ : Temp. Range</li> <li>□□ : Package Code</li> </ul>	<p>Package Code K : SOP-14</p> <p>Operating Junction Temp. Range C : 0 to 70°C</p> <p>Handling Code TU : Tube      TR : Tape &amp; Reel</p> <p>Lead Free Code L : Lead Free Device      Blank : Original Device</p>
<p>APW7063 K : </p>	<p>XXXXX - Date Code</p>

## Block Diagram

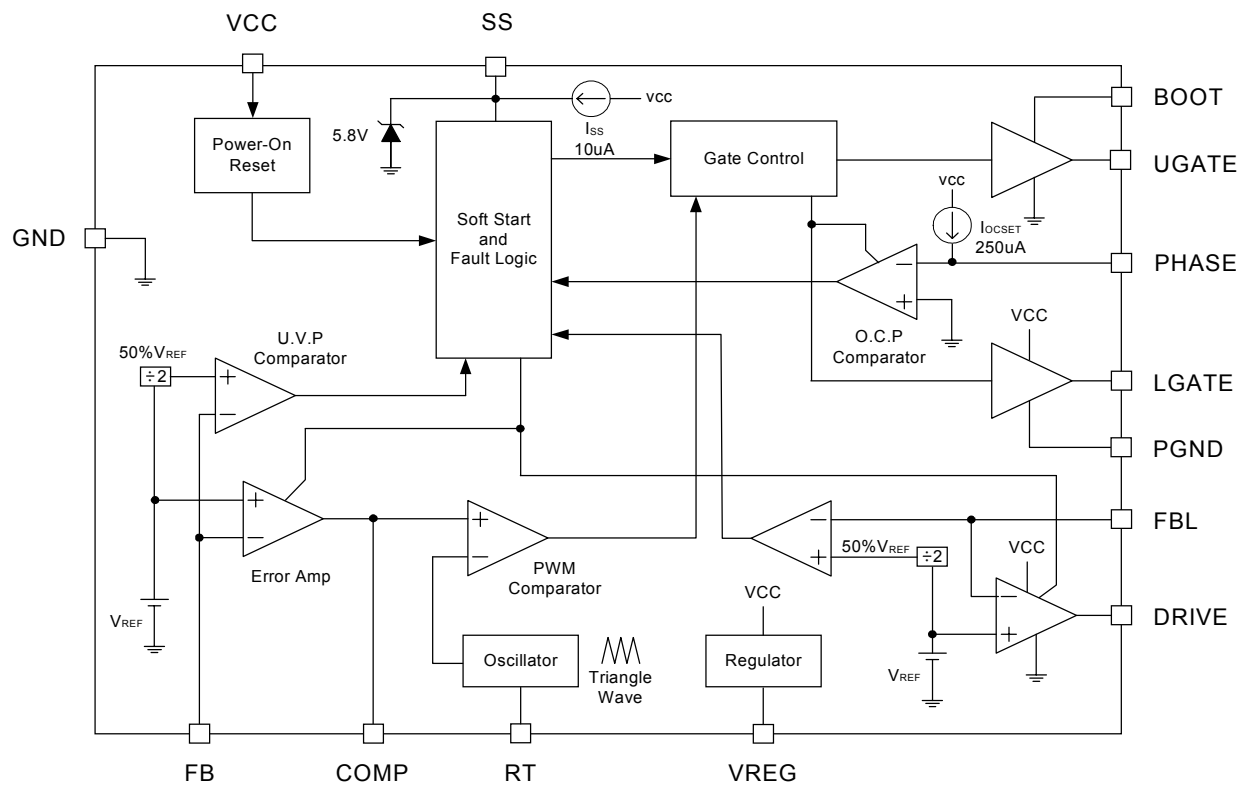

## Application Circuit

### 1. Boot-Strap - Use Internal Regulator

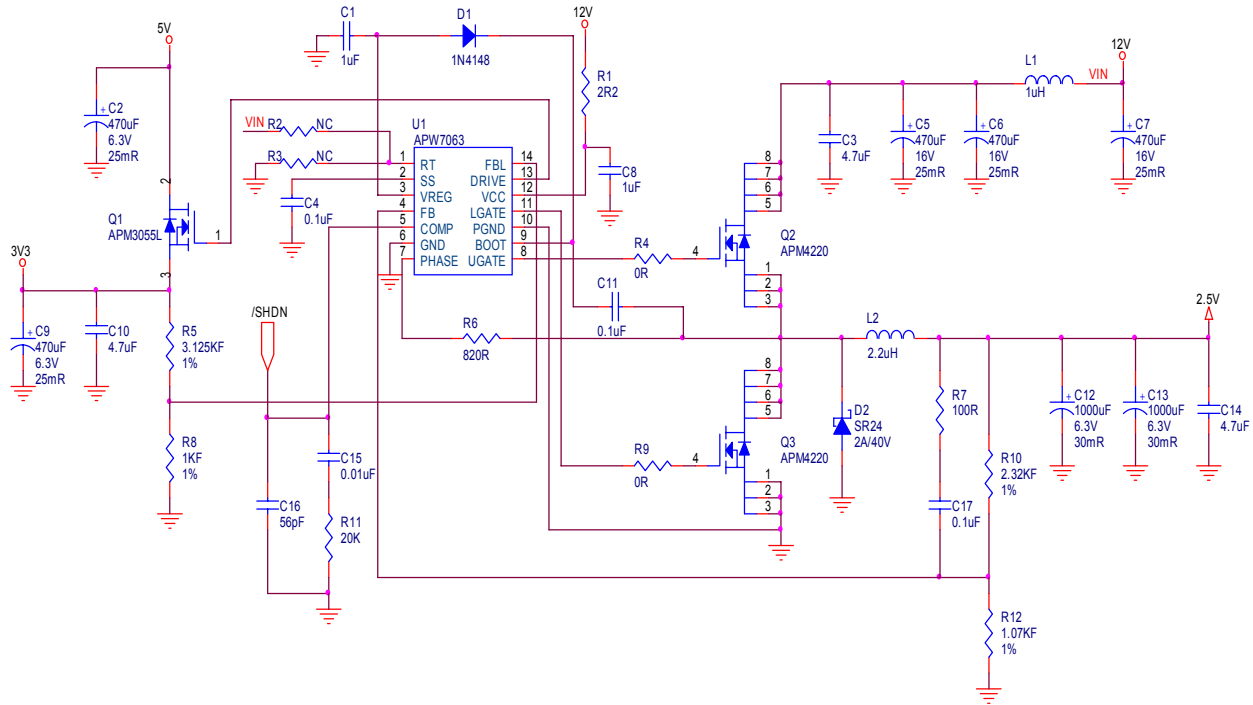

### 2. Boot-Strap - Use External Power

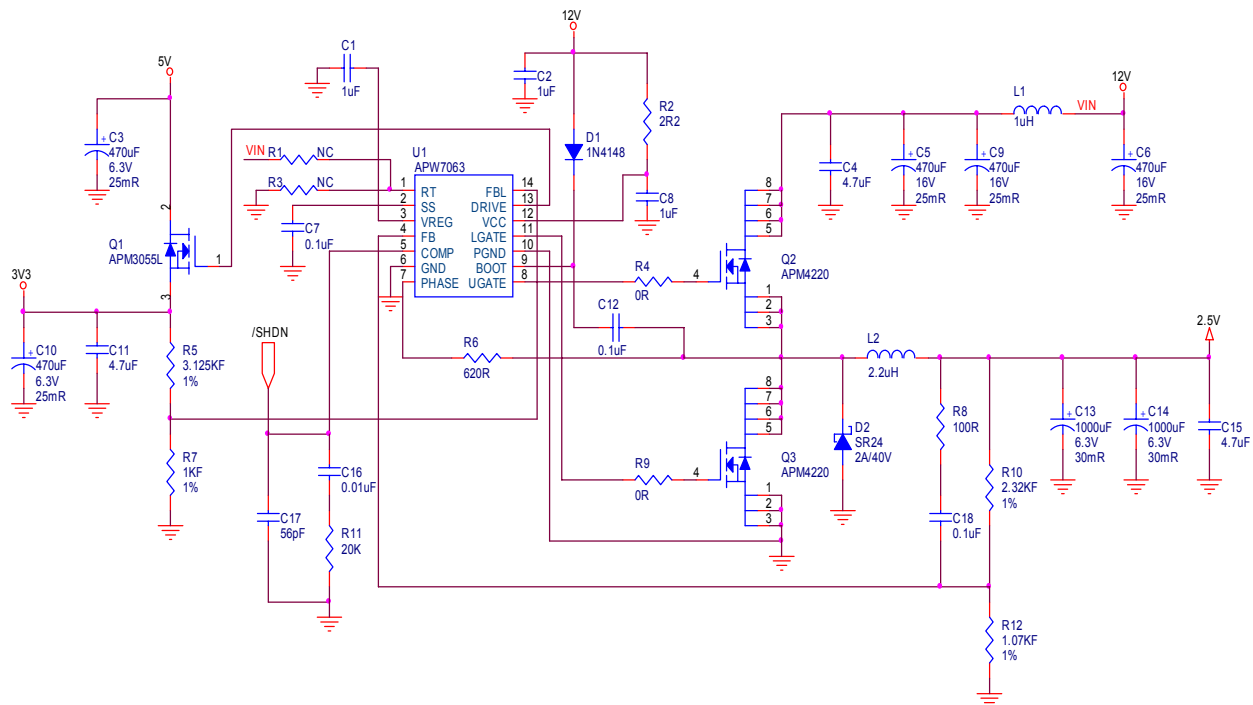

## Absolute Maximum Ratings

Symbol	Parameter	Rating	Unit
V <sub>CC</sub>	VCC to GND	30	V
LGATE	LGATE to GND	30	V
DRIVE	DRIVE to GND	30	V
UGATE	UGATE to GND	30	V
V <sub>BOOT</sub>	BOOT to GND	30	V
	PHASE to GND	30	V
	Operating Junction Temperature	0~150	°C
T <sub>STG</sub>	Storage Temperature	-65 ~ 150	°C
T <sub>SDR</sub>	Soldering Temperature (10 Seconds)	300	°C
V <sub>ESD</sub>	Minimum ESD Rating	±2	KV

## Recommended Operating Conditions

Symbol	Parameter	Min.	Nom.	Max.	Unit
V <sub>CC</sub>	Supply Voltage	7	12	19	V
V <sub>BOOT</sub>	Boot Voltage			26	V

## Thermal Characteristics

Symbol	Parameter	Value	Unit
θ <sub>JA</sub>	Junction to Ambient Resistance in free air (SOP-14)	160	°C/W

## Electrical Characteristics

Unless otherwise specified, these specifications apply over V<sub>CC</sub>=12V, V<sub>BOOT</sub>=12V, R<sub>T</sub>=OPEN and T<sub>A</sub>=0~70°C. Typical values are at T<sub>A</sub>=25°C.

Symbol	Parameter	Test Conditions	APW7063			Unit
			Min	Typ	Max	
<b>SUPPLY CURRENT</b>						
I <sub>CC</sub>	VCC Nominal Supply	UGATE and LGATE Open		3		mA
<b>POWER-ON-RESET</b>						
	Rising V <sub>CC</sub> Threshold		4.0	4.2	4.4	V
	Falling V <sub>CC</sub> Threshold		3.8	4.0	4.2	V

## Electrical Characteristics (Cont.)

Unless otherwise specified, these specifications apply over  $V_{CC}=12V$ ,  $V_{BOOT}=12V$ ,  $R_T=OPEN$  and  $T_A=0\sim70^{\circ}C$ . Typical values are at  $T_A=25^{\circ}C$ .

Symbol	Parameter	Test Conditions	APW7063			Unit
			Min	Typ	Max	
<b>OSCILLATOR</b>						
	Free Running Frequency	$R_T=OPEN, V_{CC}=12V$	220	250	280	kHz
	Total Variation	$6K\Omega < R_T \text{ to GND} < 200K\Omega$	-15		+15	%
	Ramp Amplitude	$R_T=OPEN$		1.7		V <sub>P-P</sub>
<b>REFERENCE</b>						
$V_{REF}$	Reference Voltage			0.80		V
	Reference Voltage Tolerance		-1		+1	%
<b>PWM ERROR AMPLIFIER</b>						
	DC Gain			75		dB
	UGATE Duty Range		0		85	%
	FB Input Current				0.1	uA
<b>GATE DRIVERS</b>						
$I_{UGATE}$	Upper Gate Source	$V_{BOOT}=12V, V_{UGATE}=6V$	650	800		mA
$R_{UGATE}$	Upper Gate Sink	$I_{UGATE}=0.3A$		4	8	$\Omega$
$I_{LGATE}$	Lower Gate Source	$V_{CC}=12V, V_{LGATE}=6V$	550	700		mA
$R_{LGATE}$	Lower Gate Sink	$I_{LGATE}=0.3A$		4	8	$\Omega$
$T_D$	Dead Time			50		nS
<b>LINEAR REGULATOR</b>						
	Reference Voltage			0.8		V
	Regulation			2		%
	Output Drive Current	$V_{DRIVE}=4V$	8	10	12	mA
<b>PROTECTION</b>						
	FB Under Voltage Level			50		%
	FBL Under Voltage Level			50		%
	OCSET Source Current			250		$\mu A$
<b>VREG</b>						
$V_{REG}$	Output Voltage Accuracy	$V_{CC}\geq 12V$	5.5	6	6.5	V
$I_{OUT}$	Output Current Capacity	$V_{CC}=12V$		20		mA
<b>SOFT START and SHUTDOWN</b>						
$T_{SS}$	Internal Soft-Start Interval	$C_{SS}=0\mu F$		2		mS
$I_{SS}$	Soft-Start Charge Current		8	10	12	uA
	Shutdown Threshold	COMP Falling		0.4		V
	Shutdown Hysteresis			50		mV

## Functional Pin Description

### RT (Pin 1)

This pin can adjust the switching frequency. Connect a resistor from RT to V<sub>CC</sub> for decreasing the switching frequency, Conversely, connect a resistor from RT to GND for increasing the switching frequency (see Typical Characteristics).

### SS (Pin 2)

Connect a capacitor from this pin to GND to set the soft-start interval of the converter. An internal 10μA current source charges this capacitor to 5.2V. The SS voltage clamps the reference voltage to the SS voltage, and Figure1 shows the soft-start interval. At t<sub>0</sub>, the internal source current starts to charge the capacitor and the internal 0.8V reference also starts to rise and follows the SS. Until the internal reference reaches to 0.8V at t<sub>2</sub>, the soft-start interval is completed. This method provides a rapid and controlled output voltage rise. The way of the Soft-Start of the output2 is the same as the output1, but it starts from the SS at 2.2V to 3.0V. The APW7063 also provides the internal Soft-Start which is fixed to 2ms (t<sub>0</sub> to t<sub>1</sub>). If the external Soft-Start interval is slower than the internal Soft-Start interval (C<sub>SS</sub><0.025μF) or no external capacitor, the Soft-Start will follow the internal Soft-Start.

$$T_{\text{Soft-Start}} = t_1 - t_0 = \frac{C_{SS}}{I_{SS}} \times 0.8V$$

$$t_3 = t_2 + \frac{C_{SS}}{I_{SS}} \times 0.8V$$

Where:

C<sub>SS</sub> = external Soft-Start capacitor

I<sub>SS</sub> = Soft-Start current = 10μA

$$t_2 = \frac{C_{SS}}{I_{SS}} \times 2.2V$$

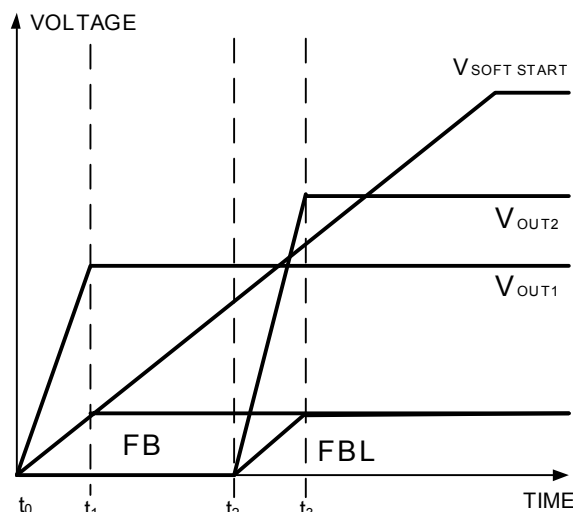

Figure 1. Soft-Start Interval

### VREG (Pin 3)

An internal regulator will supply 6V for boost voltage, a 1μF capacitor to GND is recommended for stability. If the VREG voltage has variation by other interference, the IC can not work normally. When the V<sub>CC</sub><8V, don't use the VREG for BOOST voltage.

### FB (Pin 4)

FB pin is the inverting input of the error amplifier, and it receives the feedback voltage from an external resistive divider across the output (V<sub>OUT</sub>). The output voltage is determined by :

$$V_{OUT} = 0.8V \times \left( 1 + \frac{R_{OUT}}{R_{GND}} \right)$$

where R<sub>OUT</sub> is the resistor connected from V<sub>OUT</sub> to FB, and R<sub>GND</sub> is the resistor connected from FB to GND.

When the FB voltage is under 50% V<sub>ref</sub>, it will cause the under voltage protection, and shutdown the device. Remove the condition and restart the V<sub>CC</sub> voltage or pull the COMP from low to high once, will enable the device again.

## Functional Pin Description (Cont.)

### COMP (Pin 5)

This pin is the output of the error amplifier. Add an external resistor and capacitor network to provide the loop compensation for the PWM converter (see Application Information).

Pull this pin below 0.4V will shutdown the controller, forcing the UGATE and LGATE signals to be 0V. A soft start cycle will be initiated upon the release of this pin.

### GND (Pin 6)

Signal ground for the IC.

### PHASE (Pin 7)

A resistor ( $R_{OCSET}$ ) is connected between this pin and the drain of the low-side MOSFET will determine the over current limit. An internally generated 250uA current source will flow through this resistor, creating a voltage drop. This voltage will be compared with the voltage across the low-side MOSFET. The threshold of the over current limit is therefore given by :

$$R_{OCSET} = \frac{I_{LIMIT} \times R_{DS(ON)}}{250\mu A}$$

An over current condition will cycle the soft start function until the over current condition is removed. Because of the comparator delay time, so the on time of the low-side MOSFET must be longer than 800ns to have the over current protection work.

### UGATE (Pin 8)

This pin provides gate drive for the high-side MOSFET.

### BOOT (Pin 9)

This pin provides the supply voltage to the high side MOSFET driver. For driving logic level N-channel MOSFET, a bootstrap circuit can be used to create a suitable driver's supply.

### PGND (Pin 10)

Power ground for the gate driver. Connect the lower MOSFET source to this pin.

### LGATE (Pin 11)

This pin provides the gate drive signal for the low side MOSFET.

### VCC (Pin 12)

This pin provides a supply voltage for the device, when VCC is above the rising threshold 4.2V, It turns on the device is turned on, and conversely, VCC is below the falling threshold 3.9V, the device is turned off. A 1uF decoupling capacitor to GND is recommended.

### DRIVE (Pin 13)

Connect this pin to the gate of an external N-channel MOSFET transistor. This pin provides the gate voltage for the linear regulator pass transistor. It also provides a means of compensating the linear controller for applications where the user needs to optimize the regulator transient response.

### FBL (Pin 14)

Connect this pin to the output of the linear regulator via a proper sized resistor divider. The voltage at this pin is regulated to 0.8V and the output voltage is determined using the following formula :

$$V_{OUT} = 0.8V \times \left( 1 + \frac{R_{OUT}}{R_{GND}} \right)$$

where  $R_{OUT}$  is the resistor connected from  $V_{OUT}$  to FBL, and  $R_{GND}$  is the resistor connected from FBL to GND.

This pin also monitors the under-voltage events, if the linear regulator is not used, tie the FBL to VREG.

## Typical Characteristics

Power Up

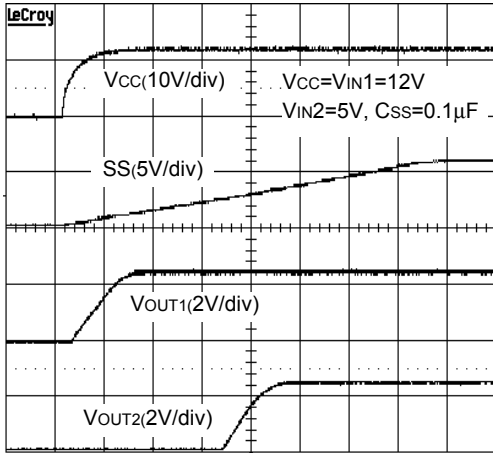

Power Down

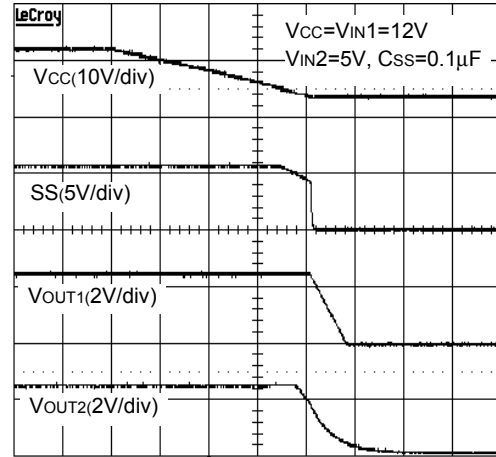

Enable (COMP is left open)

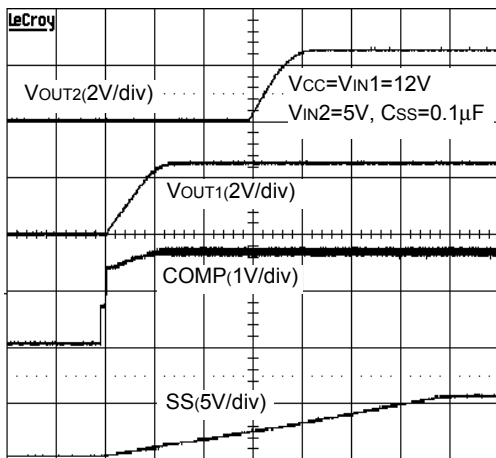

Shutdown (COMP is pulled to GND)

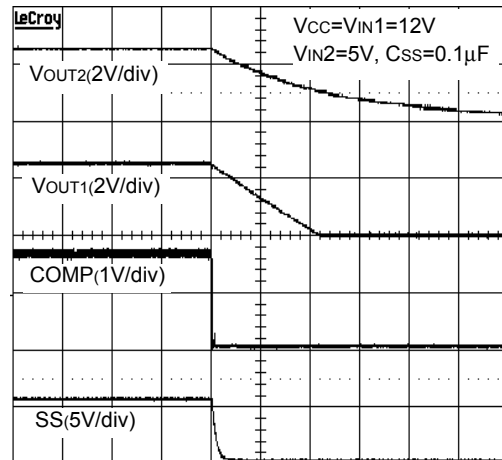



Typical Characteristics (Cont.)

UGATE Falling

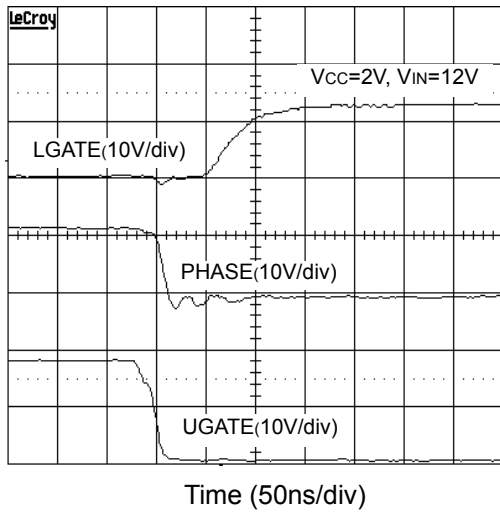

UGATE Rising

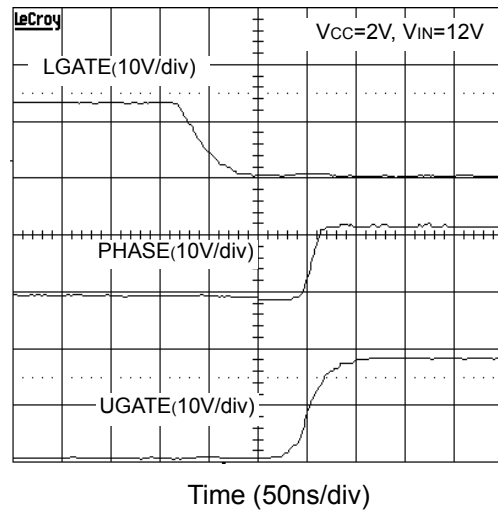

Under Voltage Protection (PWM)

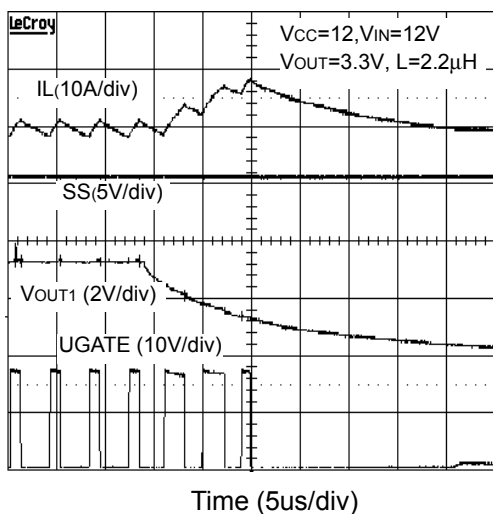

Under Voltage Protection (Linear)

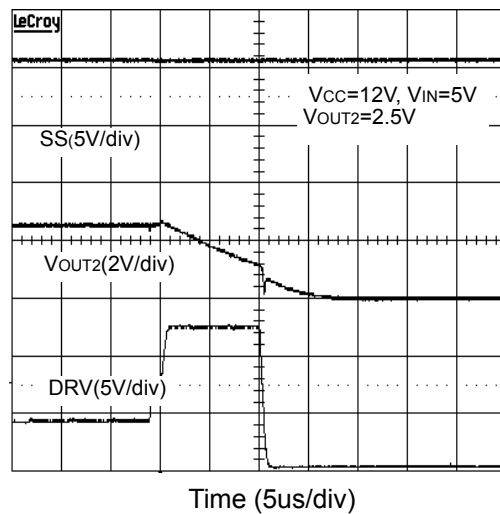

Typical Characteristics (Cont.)

PWM Load Transient

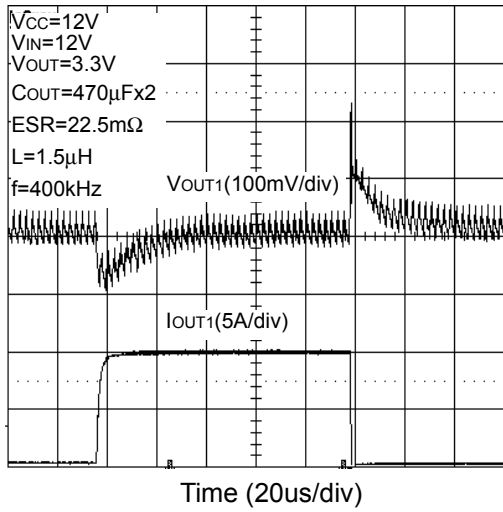

Linear Load Transient

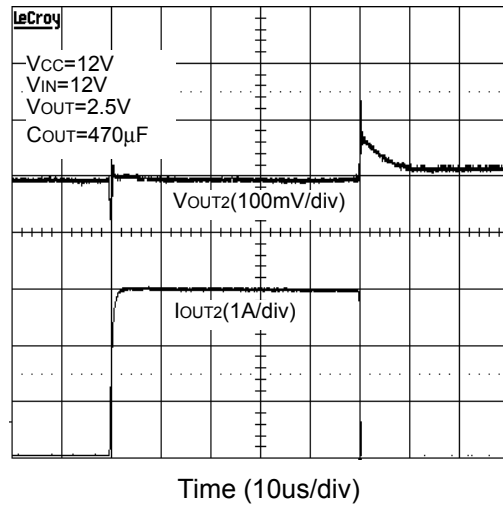

UGATE Source Current vs. UGATE Voltage

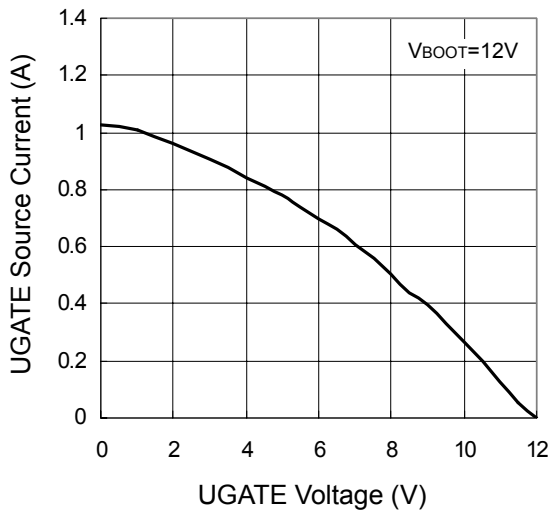

UGATE Sink Current vs. UGATE Voltage

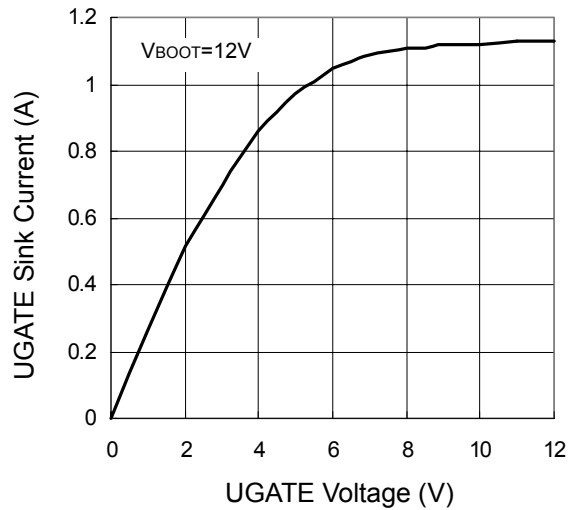

## Typical Characteristics (Cont.)

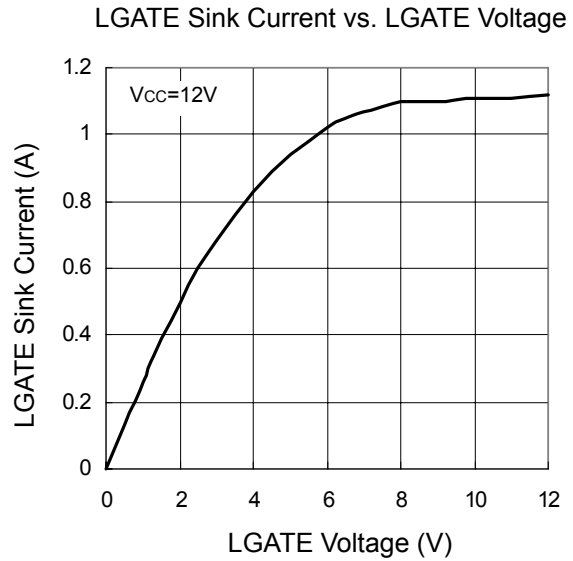
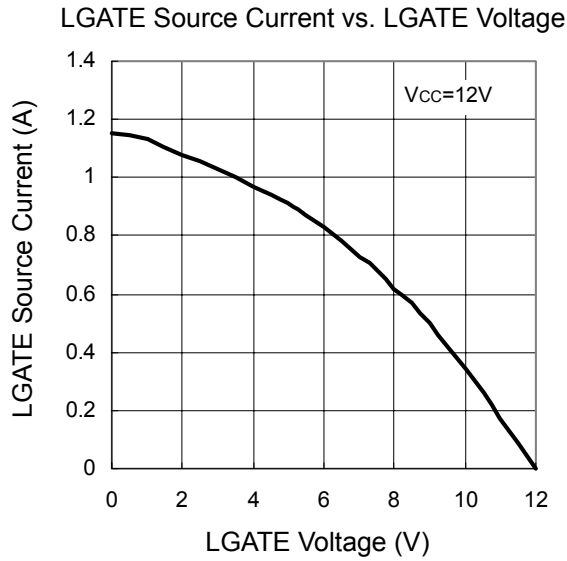

### Over Current Protection

V<sub>CC</sub>=12V, V<sub>IN</sub>=12V, V<sub>OUT</sub>=2.5V, R<sub>OCSET</sub>=1kΩ  
 R<sub>DS(ON)</sub>=16mΩ, L=2.2μH, I<sub>OUT</sub>=15A

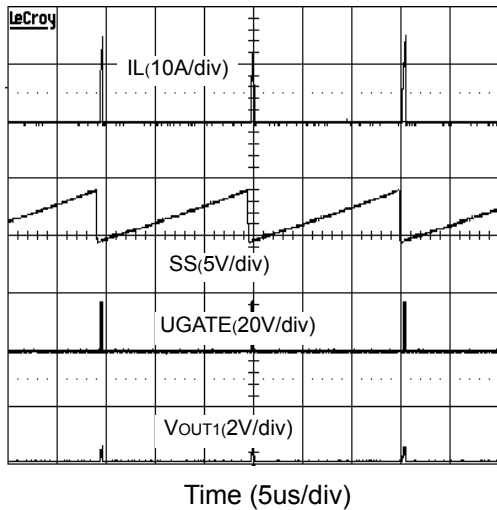

### Switching Frequency vs. RT Resistance

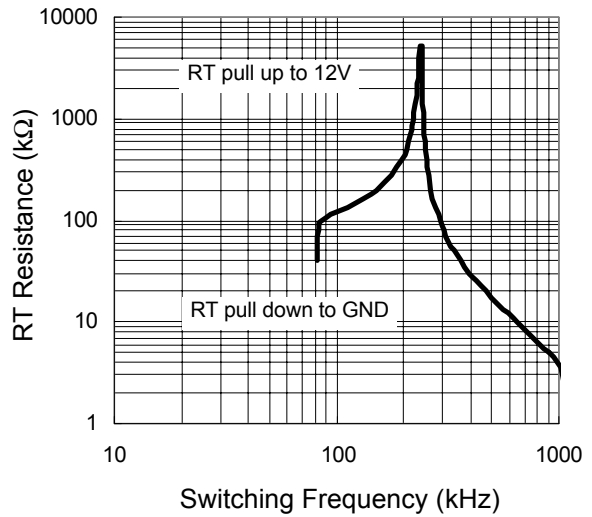

Typical Characteristics (Cont.)

Comp Sink Current vs. Comp Voltage

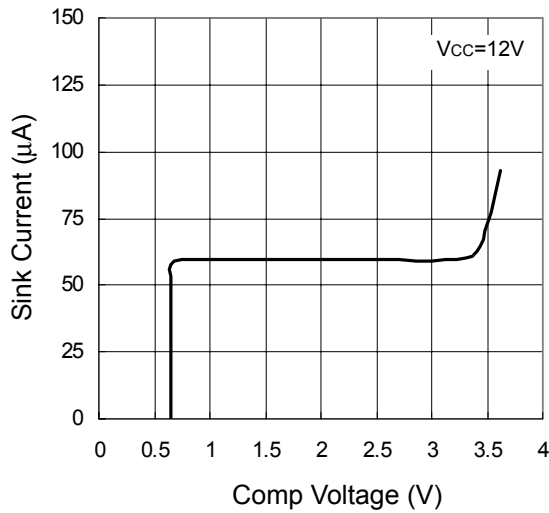

Comp Source Current vs. Comp Voltage

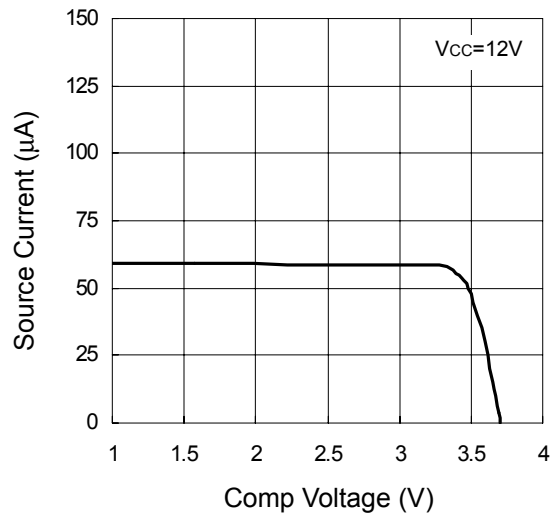

Drive Sink Current vs. Drive Voltage

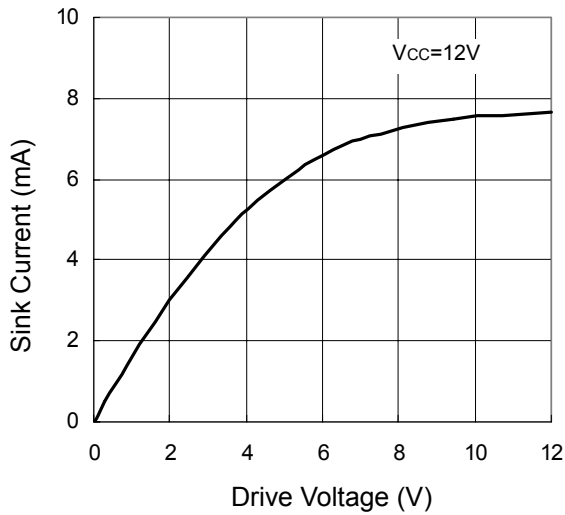

Drive Source Current vs. Drive Voltage

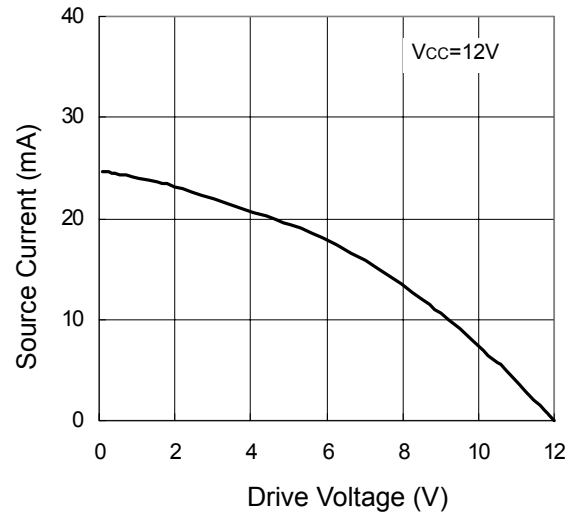

Typical Characteristics (Cont.)

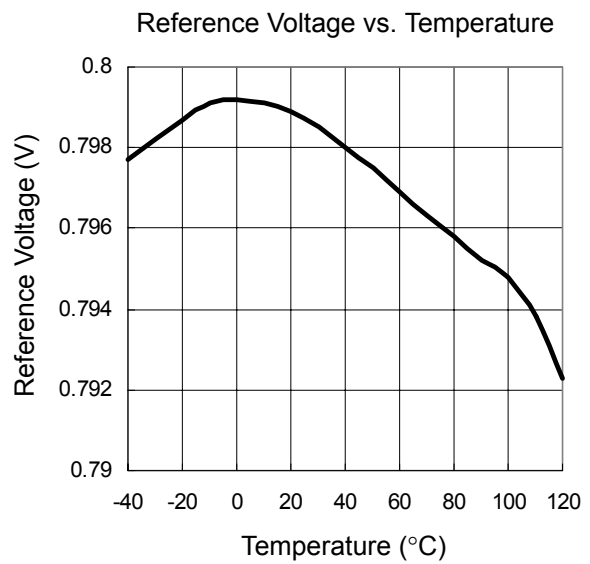
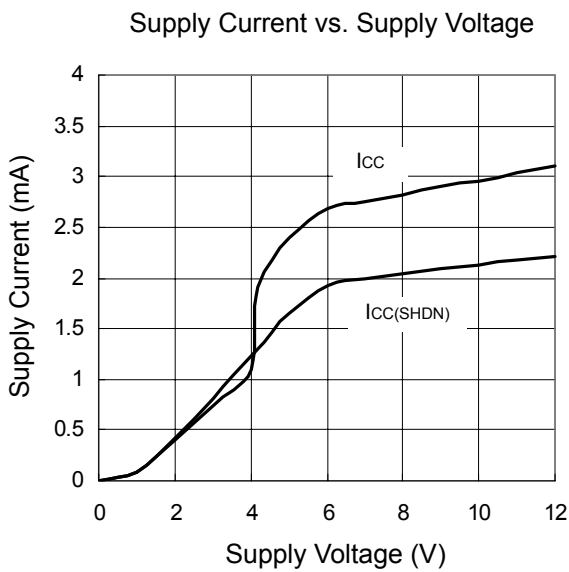
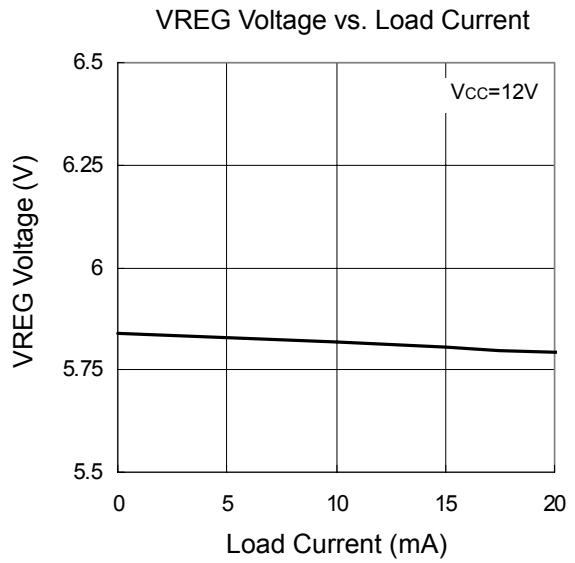
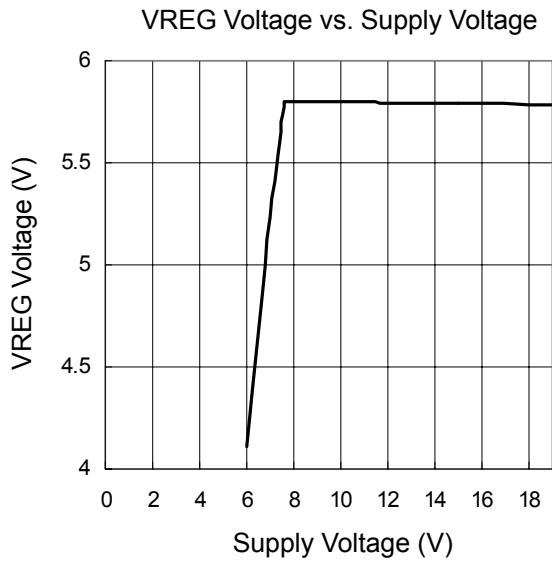

## Application Information

### Component Selection Guidelines

#### Output Capacitor Selection

The selection of  $C_{OUT}$  is determined by the required effective series resistance (ESR) and voltage rating rather than the actual capacitance requirement. Therefore select high performance low ESR capacitors that are intended for switching regulator applications. In some applications, multiple capacitors have to be paralleled to achieve the desired ESR value. If tantalum capacitors are used, make sure they are surge tested by the manufactures. If in doubt, consult the capacitors manufacturer.

#### Input Capacitor Selection

The input capacitor is chosen based on the voltage rating and the RMS current rating. For reliable operation, select the capacitor voltage rating to be at least 1.3 times higher than the maximum input voltage. The maximum RMS current rating requirement is approximately  $I_{OUT}/2$ , where  $I_{OUT}$  is the load current. During power up, the input capacitors have to handle large amount of surge current. If tantalum capacitors are used, make sure they are surge tested by the manufactures. If in doubt, consult the capacitors manufacturer.

For high frequency decoupling, a ceramic capacitor between 0.1 $\mu$ F to 1 $\mu$ F can be connected between  $V_{CC}$  and ground pin.

#### Inductor Selection

The inductance of the inductor is determined by the output voltage requirement. The larger the inductance, the lower the inductor's current ripple. This will translate into lower output ripple voltage. The ripple current and ripple voltage can be approximated by:

$$I_{RIPPLE} = \frac{V_{IN} - V_{OUT}}{F_s \times L} \times \frac{V_{OUT}}{V_{IN}}$$

$$\Delta V_{OUT} = I_{RIPPLE} \times ESR$$

where  $F_s$  is the switching frequency of the regulator.

There is a tradeoff exists between the inductor's ripple current and the regulator load transient response time. A smaller inductor will give the regulator a faster load transient response at the expense of higher ripple current and vice versa. The maximum ripple current occurs at the maximum input voltage. A good starting point is to choose the ripple current to be approximately 30% of the maximum output current.

Once the inductance value has been chosen, select an inductor that is capable of carrying the required peak current without going into saturation. In some type of inductors, especially core that is made of ferrite, the ripple current will increase abruptly when it saturates. This will result in a larger output ripple voltage.

#### Compensation

The output LC filter of a step down converter introduces a double pole, which contributes with  $-40$ dB/decade gain slope and 180 degrees phase shift in the control loop. A compensation network between COMP pin and ground should be added. The simplest loop compensation network is shown in Fig. 5.

The output LC filter consists of the output inductor and output capacitors. The transfer function of the LC filter is given by:

$$GAIN_{LC} = \frac{1 + s \times ESR \times C_{OUT}}{s^2 \times L \times C_{OUT} + s \times ESR \times C_{OUT} + 1}$$

## Application Information (Cont.)

### Compensation (Cont.)

The poles and zero of this transfer function are:

$$F_{LC} = \frac{1}{2 \times \pi \times \sqrt{L \times C_{OUT}}}$$

$$F_{ESR} = \frac{1}{2 \times \pi \times ESR \times C_{OUT}}$$

The  $F_{LC}$  is the double poles of the LC filter, and  $F_{ESR}$  is the zero introduced by the ESR of the output capacitor.

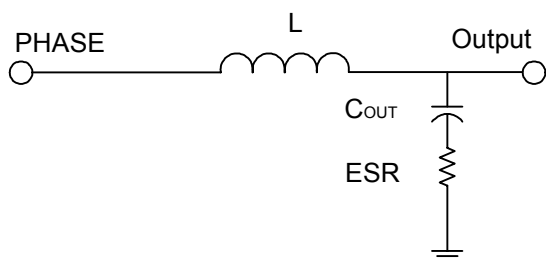

Figure 2. The Output LC Filter

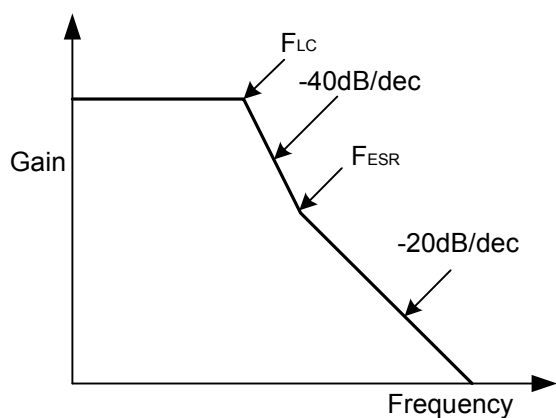

Figure 3. The LC Filter Gain & Frequency

The PWM modulator is shown in Figure 4. The input is the output of the error amplifier and the output is the PHASE node. The transfer function of the PWM modulator is given by:

$$GAIN_{PWM} = \frac{V_{IN}}{\Delta V_{OSC}}$$

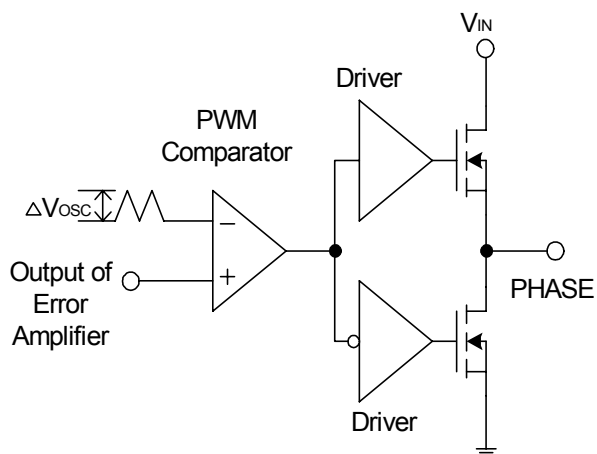

Figure 4. The PWM Modulator

The compensation circuit is shown in Figure 5. R3 and C1 introduce a zero and C2 introduces a pole to reduce the switching noise. The transfer function of error amplifier is given by:

$$GAIN_{AMP} = gm \times Z_o = gm \times \left[ \left( R3 + \frac{1}{sC1} \right) // \frac{1}{sC2} \right]$$

$$= gm \times \frac{(R3sC1 + 1)}{s \times \left( s + \frac{C1 + C2}{R3 \times C1 \times C2} \right)}$$

The pole and zero of the compensation network are:

$$F_P = \frac{1}{2 \times \pi \times R3 \times \frac{C1 \times C2}{C1 + C2}}$$

$$F_Z = \frac{1}{2 \times \pi \times R3 \times C1}$$

## Application Information (Cont.)

### Compensation (Cont.)

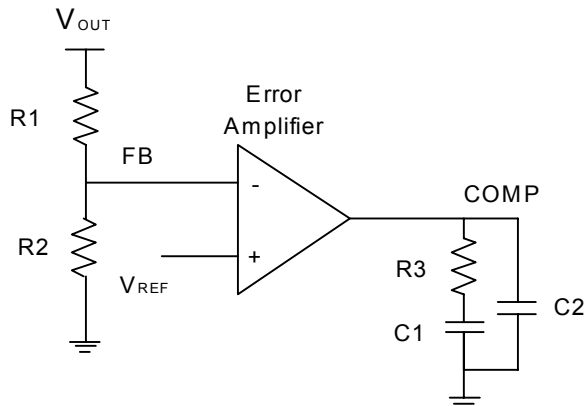

Figure 5. Compensation Network

The closed loop gain of the converter can be written as:

$$GAIN_{LC} \times GAIN_{PWM} \times \frac{R2}{R1+R2} \times GAIN_{AMP}$$

Figure 6 shows the converter gain and the following guidelines will help to design the compensation network.

1. Select the desired zero crossover frequency  $F_o$ :  
 $(1/5 \sim 1/10) \times F_s > F_o > F_z$

Use the following equation to calculate R3:

$$R3 = \frac{\Delta V_{OSC}}{V_{IN}} \times \frac{F_{ESR}}{F_{LC}^2} \times \frac{R1+R2}{R2} \times \frac{F_o}{gm}$$

Where:

$$gm=900\mu A/V$$

2. Place the zero  $F_z$  before the LC filter double poles

$F_{LC}$ :

$$F_z = 0.75 \times F_{LC}$$

Calculate the C1 by the equation:

$$C1 = \frac{10}{2 \times \pi \times R1 \times F_{LC}}$$

3. Set the pole at the half the switching frequency:

$$F_p = 0.5 \times F_s$$

Calculate the C2 by the equation:

$$C2 = \frac{C1}{\pi \times R3 \times C1 \times F_s - 1}$$

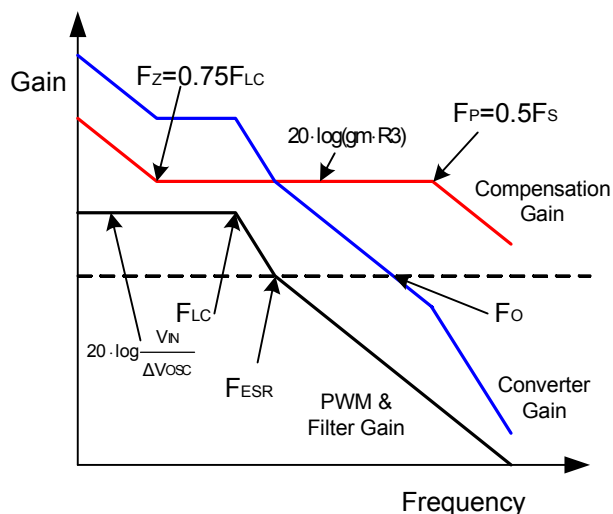

Figure 6. Converter Gain & Frequency

### MOSFET Selection

The selection of the N-channel power MOSFETs are determined by the  $R_{DS(ON)}$ , reverse transfer capacitance ( $C_{RSS}$ ) and maximum output current requirement. The losses in the MOSFETs have two components: conduction loss and transition loss. For the upper and lower MOSFET, the losses are approximately given by the following :

$$P_{UPPER} = I_{out}^2 (1+TC)(R_{DS(ON)})D + (0.5)(I_{out})(V_{IN})(t_{sw})F_s$$

$$P_{LOWER} = I_{out}^2 (1+TC)(R_{DS(ON)})(1-D)$$

where  $I_{OUT}$  is the load current

TC is the temperature dependency of  $R_{DS(ON)}$

$F_s$  is the switching frequency

$t_{sw}$  is the switching interval

D is the duty cycle



## Application Information (Cont.)

### MOSFET Selection (Cont.)

Note that both MOSFETs have conduction losses while the upper MOSFET include an additional transition loss. The switching internal,  $t_{sw}$ , is a function of the reverse transfer capacitance  $C_{RSS}$ . Figure 7 illustrates the switching waveform internal of the MOSFET.

The (1+TC) term is to factor in the temperature dependency of the  $R_{DS(ON)}$  and can be extracted from the “ $R_{DS(ON)}$  vs Temperature” curve of the power MOSFET.

### Linear Regulator Input/Output Capacitor Selection

The input capacitor is chosen based on its voltage rating. Under load transient condition, the input capacitor will momentarily supply the required transient current. A 1uF ceramic capacitor will be sufficient in most applications.

The output capacitor for the linear regulator is chosen to minimize any droop during load transient condition. In addition, the capacitor is chosen based on its voltage rating.

### Linear Regulator MOSFET Selection

The maximum DRIVE voltage is determined by the  $V_{CC}$ . Since this pin drives an external N-channel MOSFET, therefore the maximum output voltage of the linear regulator is dependent upon the  $V_{GS}$ .

$$V_{OUT2MAX} = V_{CC} - V_{GS}$$

Another criteria is its efficiency of heat removal. The power dissipated by the MOSFET is given by:

$$P_{diss} = I_{out} * (V_{IN} - V_{OUT2})$$

where  $I_{out}$  is the maximum load current

$V_{out2}$  is the nominal output voltage

In some applications, heatsink maybe required to help maintain the junction temperature of the MOSFET below its maximum rating.

### Layout Considerations

In high power switching regulator, a correct layout is important to ensure proper operation of the regulator. In general, interconnecting impedances should be minimized by using short, wide printed circuit traces. Signal and power grounds are to be kept separate and finally combined using ground plane construction or single point grounding. Figure 8 illustrates the layout, with bold lines indicating high current paths. Components along the bold lines should be placed close together. Below is a checklist for your layout:

- Keep the switching nodes (UGATE, LGATE and PHASE) away from sensitive small signal nodes since these nodes are fast moving signals. Therefore keep traces to these nodes as short as possible.
- The ground return of  $C_{IN}$  must return to the combine  $C_{OUT}$  (-) terminal.
- Capacitor  $C_{BOOT}$  should be connected as close to the BOOT and PHASE pins as possible.

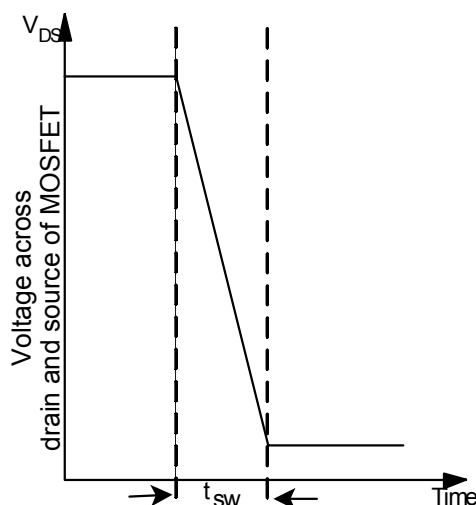

Figure 7. Switching waveform across MOSFET

Application Information (Cont.)

Layout Considerations (Cont.)

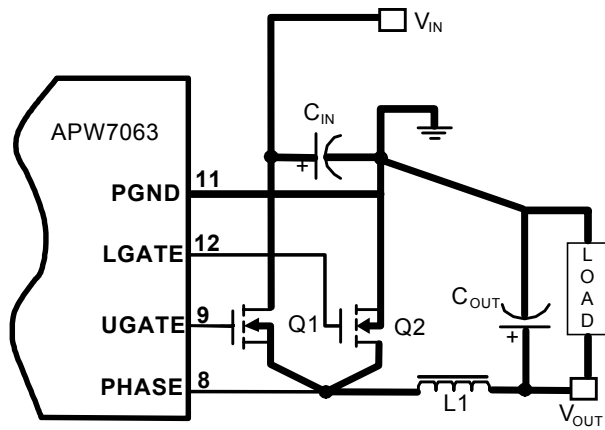
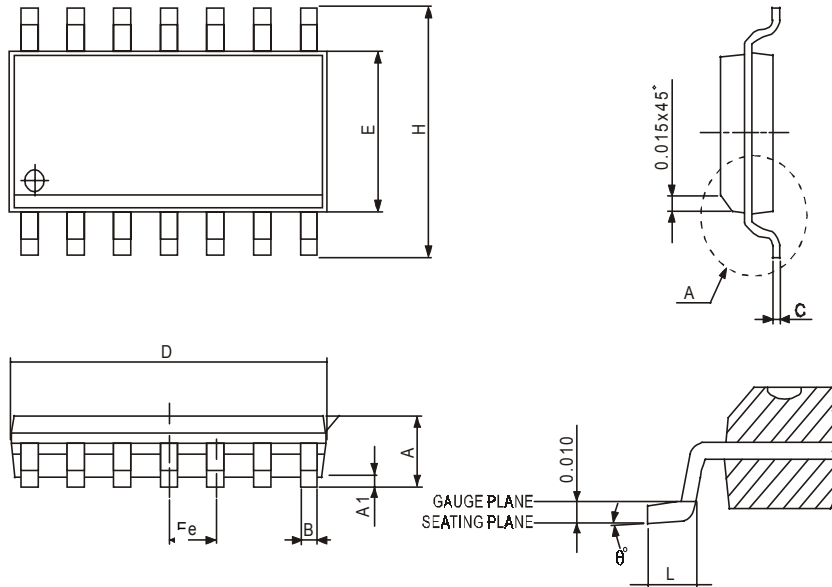

Figure 8. Recommended Layout Diagram

Package Information

SOP – 14 (150mil)



Dim	Millimeters		Inches	
	Min.	Max.	Min.	Max.
A	1.477	1.732	0.058	0.068
A1	0.102	0.255	0.004	0.010
B	0.331	0.509	0.013	0.020
C	0.191	0.2496	0.0075	0.0098
D	8.558	8.762	0.336	0.344
E	3.82	3.999	0.150	0.157
e	1.274		0.050	
H	5.808	6.215	0.228	0.244
L	0.382	1.274	0.015	0.050
θ°	0°	8°	0°	8°

## Physical Specifications

Terminal Material	Solder-Plated Copper (Solder Material : 90/10 or 63/37 SnPb), 100%Sn
Lead Solderability	Meets EIA Specification RSI86-91, ANSI/J-STD-002 Category 3.

### Reflow Condition (IR/Convection or VPR Reflow)

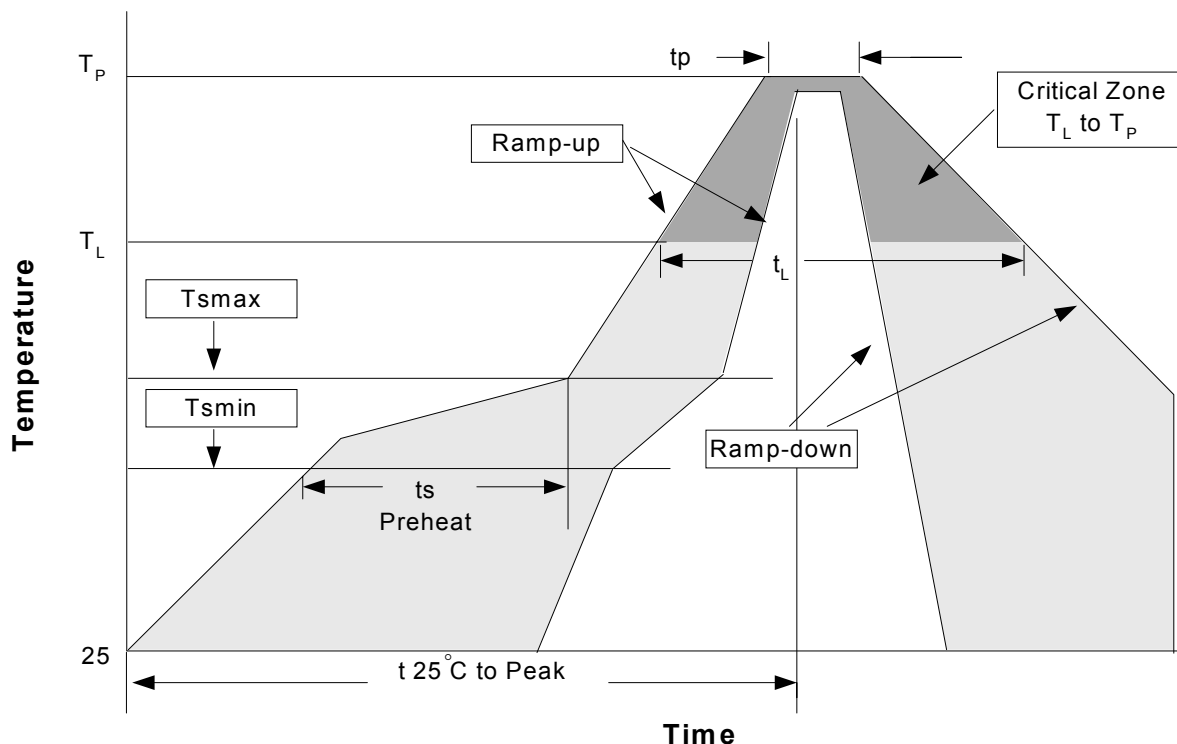

### Classification Reflow Profiles

Profile Feature	Sn-Pb Eutectic Assembly		Pb-Free Assembly	
	Large Body	Small Body	Large Body	Small Body
Average ramp-up rate ( $T_L$ to $T_P$ )	3°C/second max.		3°C/second max.	
Preheat				
- Temperature Min ( $T_{smin}$ )	100°C		150°C	
- Temperature Mix ( $T_{smax}$ )	150°C		200°C	
- Time (min to max)( $t_s$ )	60-120 seconds		60-180 seconds	
$T_{smax}$ to $T_L$				
- Ramp-up Rate			3°C/second max	
$T_{smax}$ to $T_L$				
- Temperature( $T_L$ )	183°C		217°C	
- Time ( $t_L$ )	60-150 seconds		60-150 seconds	
Peak Temperature( $T_p$ )	225 +0/-5°C	240 +0/-5°C	245 +0/-5°C	250 +0/-5°C
Time within 5°C of actual Peak Temperature( $t_p$ )	10-30 seconds	10-30 seconds	10-30 seconds	20-40 seconds
Ramp-down Rate	6°C/second max.		6°C/second max.	
Time 25°C to Peak Temperature	6 minutes max.		8 minutes max.	

Note: All temperatures refer to topside of the package. Measured on the body surface.

## Reliability test program

Test item	Method	Description
SOLDERABILITY	MIL-STD-883D-2003	245°C , 5 SEC
HOLT	MIL-STD-883D-1005.7	1000 Hrs Bias @ 125 °C
PCT	JESD-22-B, A102	168 Hrs, 100 % RH , 121°C
TST	MIL-STD-883D-1011.9	-65°C ~ 150°C, 200 Cycles
ESD	MIL-STD-883D-3015.7	VHBM > 2KV, VMM > 200V
Latch-Up	JESD 78	10ms , $I_{tr} > 100mA$

## Carrier Tape & Reel Dimension

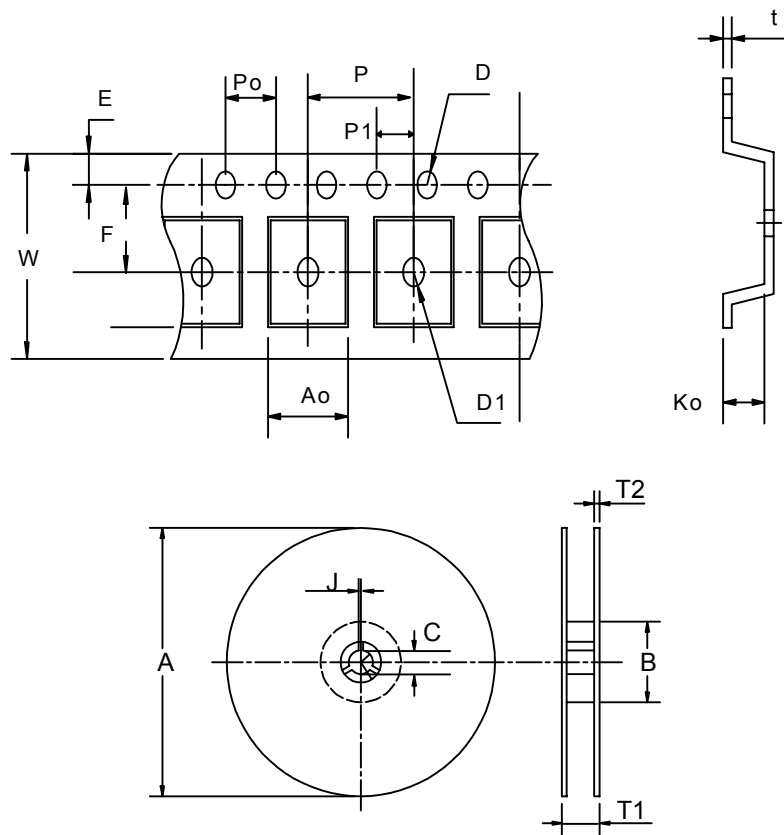

Application	A	B	C	J	T1	T2	W	P	E
SOP-14 (150mil)	330REF	100REF	13.0 + 0.5 - 0.2	2 ± 0.5	16.5REF	2.5 ± 0.25	16.0 ± 0.3	8	1.75
	F	D	D1	Po	P1	Ao	Ko	t	
	7.5	φ0.50 + 0.1	φ1.50 (MIN)	4.0	2.0	6.5	2.10	0.3±0.05	

(mm)

## Cover Tape Dimensions

Application	Carrier Width	Cover Tape Width	Devices Per Reel
SOP- 14	24	21.3	2500

## Customer Service

**Anpec Electronics Corp.**

Head Office :

5F, No. 2 Li-Hsin Road, SBIP,  
Hsin-Chu, Taiwan, R.O.C.

Tel : 886-3-5642000

Fax : 886-3-5642050

Taipei Branch :

7F, No. 137, Lane 235, Pac Chiao Rd.,  
Hsin Tien City, Taipei Hsien, Taiwan, R. O. C.

Tel : 886-2-89191368

Fax : 886-2-89191369