

## Dual Synchronous Buck PWM Controllers and One Linear Controller

### Features

- Two Synchronous Buck Converters and a Linear Regulator
- VIN range up to 12V
- Input Power Supplies Require 12V and 5V or use 12V to generate a Shunt Regulator 5.8V
- 0.6V Reference for VOUT1 and VOUT3 with 0.8% accurate
- 3.3V Reference for VOUT2 with 0.8% accurate
- Buffered VTT Reference Output
- Three Outputs have Independent Soft-Start and Enable
- Internal 300kHz Oscillator and Programmable Frequency range from 70 kHz to 800kHz
- Synchronous Switching Frequency
- DDR mode or Independent Mode Selection
- Phase Shift Selection
- Power Good Function
- Short-Circuit Protection for VOUT1 and VOUT2
- Thermally Enhanced TSSOP-24P and QFN5x5-32 Packages
- Lead Free and Green Devices Available (RoHS Compliant)

### Applications

- Graphic Cards
- DDR memory Power Supplies
- Low-Voltage Distributed Power Supplies

### General Description

The APW7066 has two synchronous buck PWM controllers and one linear controller with high precision internal references voltage to offer accurate outputs. The PWM controllers are designed to drive two N-channel MOSFETs in synchronous buck topology, and the linear controller drives an external N-channel MOSFET. The device requires 12V and 5V power supplies, if the 5V supply is not available, VCC12 can offer an optional shunt regulator 5.8V for 5V supply.

All outputs have independent soft-start and enable functions by SS/EN pins to control. Connect a capacitor from each SS/EN pin to the ground for setting the soft-start time, and pulling the SS/EN pin below 1V to disable regulator. Pull the SS2/EN2 to VCC, enter the DDR mode, the SS1/EN1 controls both VOUT1 and VOUT2, and allows VOUT2 to track VOUT1. It also offers the phase shift function by REFOUT pin to select the phase shift between VOUT1 and VOUT2 in DDR mode or Independent mode. When all SS/EN pins exceed 3.3V and no faults are detected, the PGOOD pin goes high to indicate the regulators are ready. If any of the SS/EN pins goes below 3.2V or any of the outputs has a fault condition, the PGOOD pin will be pulled low.



The internal oscillator is nominally 300kHz (keep the FS/SYNC pin open or short to GND), and it offers the programmable frequency function from 70kHz to 800kHz; connecting a resistor from FS/SYNC to VCC12 to decrease the frequency, conversely, connect a resistor from FS/SYNC to GND to increase the frequency. The IC also provides the synchronous frequency function. Connect the LGATE signal of another converter to FS/SYNC pin; forcing the switching frequency to follow the external clock. The possible synchronous frequency is from 150kHz to 800kHz. There is no  $R_{ds(on)}$  sensing or under-voltage sensing on APW7066. However, it provides a simple short-circuit protection by monitoring the COMP1 and COMP2 for over-voltage. When any of two pins exceeds their trip point and the condition persists for 1-2 internal clock cycle (3-6 $\mu$ s at 300kHz), then it will shut down all regulators.

ANPEC reserves the right to make changes to improve reliability or manufacturability without notice, and advise customers to obtain the latest version of relevant information to verify before placing orders.

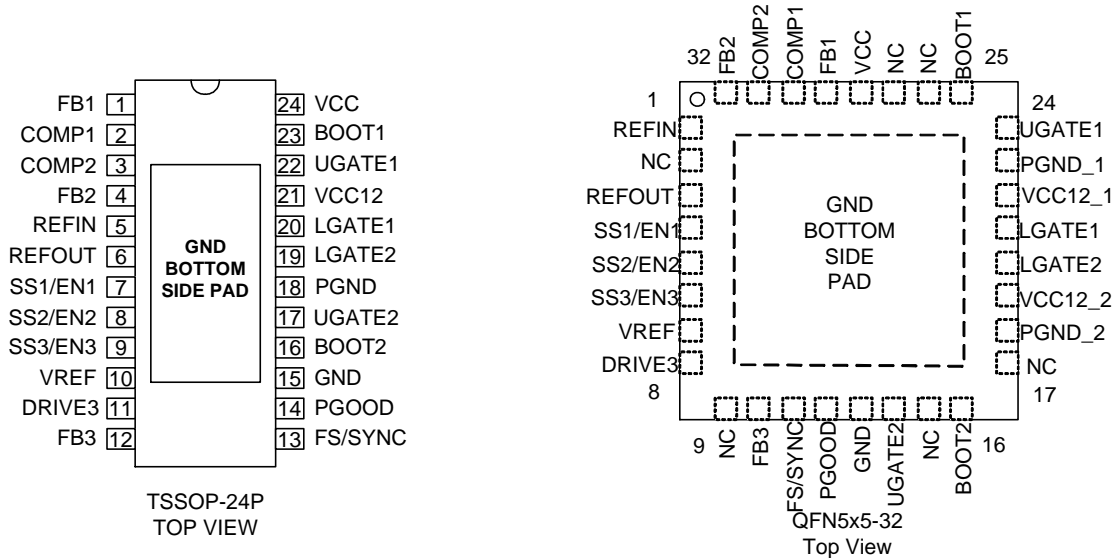
## Pin Description



## Ordering and Marking Information

<p>APW7066 □□-□□□</p> <ul style="list-style-type: none"> <li>□□ - Assembly Material</li> <li>□ - Handling Code</li> <li>□ - Temperature Range</li> <li>□ - Package Code</li> </ul>	<p>Package Code                  R : TSSOP-24P                      QA : QFN5x5-32                  Operating Ambient Temperature Range                  C : 0 to 70 °C                  Handling Code                  TR : Tape &amp; Reel                  Assembly Material                  L : Lead Free Device                  G : Halogen and Lead Free Device</p>
<p>APW7066 R : </p>	<p>XXXXX - Date Code</p>
<p>APW7066 QA : </p>	<p>XXXXX - Date Code</p>

Note: ANPEC lead-free products contain molding compounds/die attach materials and 100% matte tin plate termination finish; which are fully compliant with RoHS. ANPEC lead-free products meet or exceed the lead-free requirements of IPC/JEDEC J-STD-020C for MSL classification at lead-free peak reflow temperature. ANPEC defines "Green" to mean lead-free (RoHS compliant) and halogen free (Br or Cl does not exceed 900ppm by weight in homogeneous material and total of Br and Cl does not exceed 1500ppm by weight).

Block Diagram

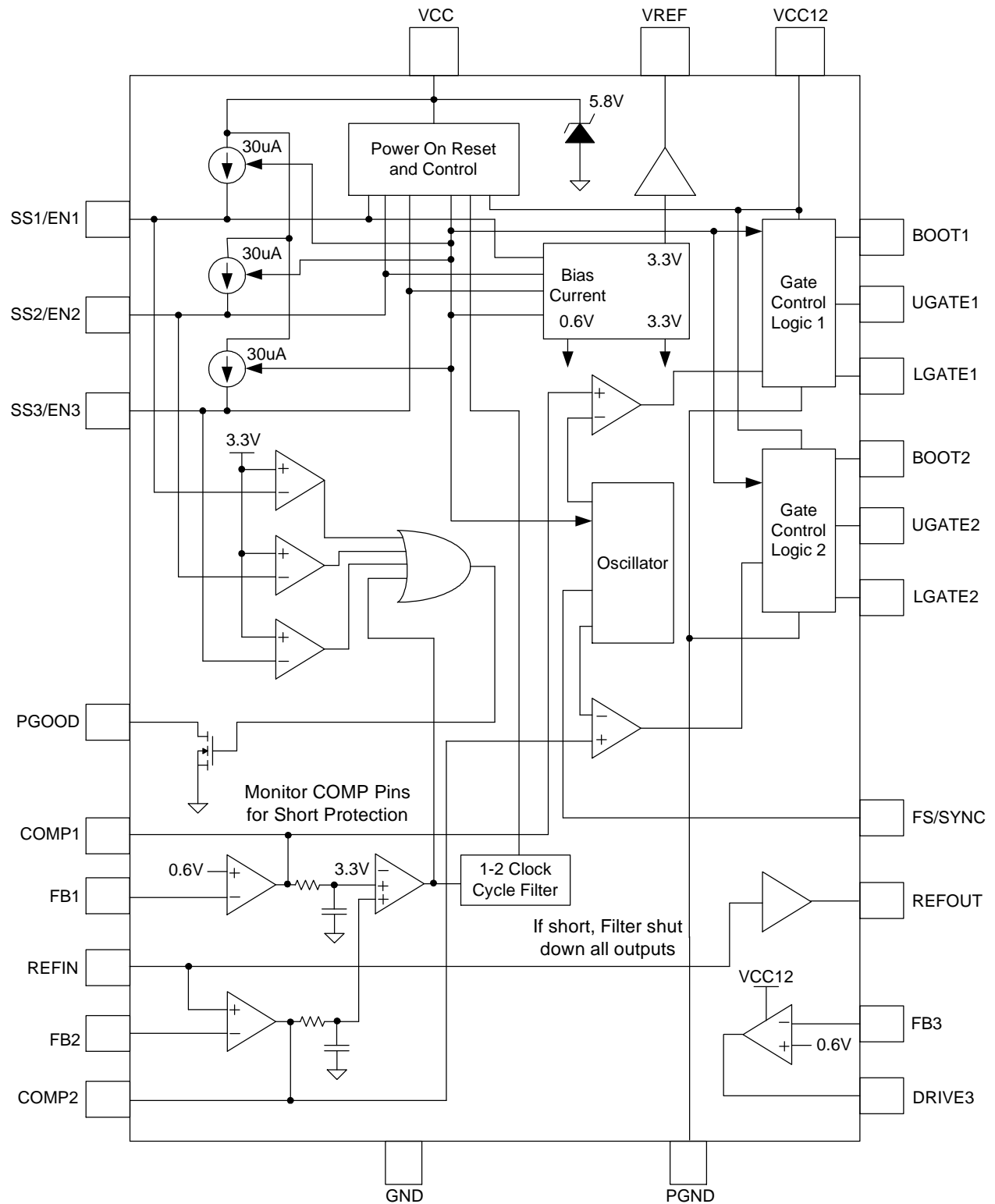

## Absolute Maximum Ratings

Symbol	Parameter	Rating	Unit
VCC12	VCC12 to GND	-0.3 to 15	V
VCC, separate supply	VCC, separate supply	-0.3 to 5.5	V
VCC, shunt regulator	VCC, shunt regulator to GND	-0.3 to 6	V
UGATE1, UGATE2, BOOT1, BOOT2	UGATE1, UGATE2, BOOT1, BOOT2 to GND	-0.3 to 30	V
LGATE1, LGATE2, DRIVE3	LGATE1, LGATE2, DRIVE3 to GND	-0.3 to 15	V
FS/SYNC	FS/SYNC to GND	-0.3 to 15	V
REFIN, REFOUT, PGOOD, VREF	REFIN, REFOUT, PGOOD, VREF to GND	-0.3 to VCC	V
FB1, COMP1, FB2, COMP2, FB3	FB1, COMP1, FB2, COMP2, FB3 to GND	-0.3 to VCC	V
SS1/EN1, SS2/EN2, SS3/EN3	SS1/EN, SS2/EN2, SS3/EN3 to GND	-0.3 to VCC	V
PGND	PGND to GND	-0.3 to +0.3	V
T <sub>A</sub>	Operating Temperature Range	0 to +70	°C
T <sub>J</sub>	Maximum Junction Temperature	+150	°C
T <sub>STG</sub>	Storage Temperature Range	-65 to +150	°C
T <sub>SDR</sub>	Lead Temperature (Soldering, 10sec)	260	°C

## Thermal Characteristics

Symbol	Parameter	Package	Value	Unit
R <sub>θJA</sub>	Thermal Resistance – Junction to Ambient	TSSOP-24P	39	°C/W
		QFN5x5-32	30	
R <sub>θJC</sub>	Thermal Resistance – Junction to Case	TSSOP-24P	5	
		QFN5x5-32	5	

## Electrical Characteristics

Operating Conditions: V<sub>CC</sub> = 5V, V<sub>CC12</sub> = 12V, T<sub>A</sub> = 0 to 70°C, Unless Otherwise Specified.

Parameter	Test Conditions	Min.	Typ.	Max.	Units
<b>INPUT SUPPLY POWER</b>					
Input Supply Current (Quiescent)	VCC; outputs disabled		4		mA
	VCC12; outputs disabled		6		mA
Input Supply Current (Dynamic)	VCC12; UGATEs, LGATEs CL = 1nF, 300KHz		50		mA
	VCC; UGATEs, LGATEs CL = 1nF, 300KHz		7		mA
Shunt Regulator Output Voltage	20mA current; ~Equivalent to 300Ω resistor VCC to 12V	5.6	5.8	6.0	V
Shunt Regulator Current	300Ω resistor VCC to 12V		20	60	mA

## Electrical Characteristics (Cont.)

Operating Conditions:  $V_{CC} = 5V$ ,  $V_{CC12} = 12V$ ,  $T_A = 0$  to  $70^{\circ}C$ , unless Otherwise Specified.

Parameter	Test Conditions	APW7066			Units
		Min.	Typ.	Max.	
<b>INPUT SUPPLY POWER</b>					
Power-On Reset Threshold	VCC Rising	4.15	4.23	4.4	V
	VCC Falling	3.9	4.0	4.15	V
	VCC12 Rising	7.55	7.8	8	V
	VCC12 Falling	7.1	7.3	7.55	V
<b>SYSTEM ACCURACY</b>					
Outputs 1 and 3 Reference Voltage			0.6		V
Output 2 Reference Voltage			3.3V		
Outputs 1 and 2 System Accuracy		-0.8		0.8	%
Output 3 System Accuracy		-0.8		0.8	%
<b>OSCILLATOR</b>					
Accuracy		-20		20	%
Frequency	FS/SYNC pin open	240	300	360	KHz
Adjustment Range	FS/SYNC pin: resistor to GND; resistor to VCC12	70		800	KHz
Sawtooth Amplitude			2.1		V
Duty-Cycle Range		0		85	%
<b>ERROR AMPLIFIER (OUT1 and OUT2)</b>					
Open-Loop Gain	RL = 10k $\Omega$ to ground		85		dB
Open-Loop Bandwidth	CL = 100pF, RL = 10k $\Omega$ to ground		15		MHz
Slew Rate	CL = 100pF, RL = 10k $\Omega$ to ground		4		V/ $\mu$ s
EA Offset	COMP1/2 to FB1/2; compare to internal VREF/REFIN		2		mV
Maximum Output Voltage	RL = 10k $\Omega$ to ground; (may trip short-circuit)		VCC		V
Output High Source Current	COMP1/2, VCOMP=2V		-50		mA
Output Low Sink Current	COMP1/2, VCOMP=2V		45		mA
<b>PROTECTION AND MONITOR</b>					
Under-Voltage Threshold (COMP1 and COMP2)	Causes PGOOD to go low; if there for a filter time, implies the COMP pin(s) is out-of-range, and shuts down IC		3.3		V
UV filter time	Based on internal oscillator clock frequency (nominal 300kHz = 3.3 $\mu$ s clock period)	1		2	Clock pulses
PGOOD Low Voltage	IPGOOD = 2mA		0.1	0.3	V

## Electrical Characteristics (Cont.)

Operating Conditions:  $V_{CC} = 5V$ ,  $V_{CC12} = 12V$ ,  $T_A = 0$  to  $70^{\circ}C$ , Unless Otherwise Specified.

Parameter	Test Conditions	APW7066			Units
		Min.	Typ.	Max.	
<b>LINEAR REGULATOR (OUT3)</b>					
EA Offset	DRIVE3 to FB3; compare to internal VREF		2		mV
DRIVE3 High Output Voltage			VCC12		
DRIVE3 High Output Source Current			1.5		mA
DRIVE3 Low Output Sink Current			2.5		mA
<b>VREF</b>					
Output Voltage	1.1 $\mu$ F max capacitance		3.3		V
Output Accuracy		-0.8		+0.8	%
Source Current				2.0	mA
<b>REFOUT (VTTREF)</b>					
Output Voltage	Determined by REFIN voltage	0.6		3.3	V
Offset Voltage		-10		+10	mV
Source Current		0.2		20	mA
Sink Current				0.48	mA
Output Capacitance			0.1		$\mu$ F
Output High Voltage Minimum	To select 0 degree phase; see Table 1		3.8	VCC	V
<b>ENABLE/SOFTSTART (SS/EN 1,2,3)</b>					
Enable Threshold	EN Rising		1.05		V
	EN falling		0.95		
Soft-Start Current			-30		$\mu$ A
Soft-Start High Voltage	End of ramp		3.5		V
Output High Voltage	To select DDR mod; see Table 1		3.8	VCC	V
<b>FS/SYNC PLL</b>					
Frequency range of Lock-in		150		800	KHz
High Voltage	( from LG pin of another IC, for example)			12	V
<b>GATE DRIVERS</b>					
Output1 GATE Driver Source	UGATE1, LGATE1=3V, BOOT=12V		1.8		A
Output2 GATE Driver Source	UGATE2, LGATE2=3V, BOOT=12V		1		A
Output1 GATE Driver Sink	UGATE1, LGATE1=3V, BOOT=12V		2.5		$\Omega$
Output2 GATE Driver Sink	UGATE2, UGATE2=3V, BOOT=12V		4		$\Omega$
Output Voltage	UGATE1, UGATE2			30	V
Output Voltage	LGATE1, LGATE2		12		V

# Typical Application Circuit

APW7066  
DDR MODE

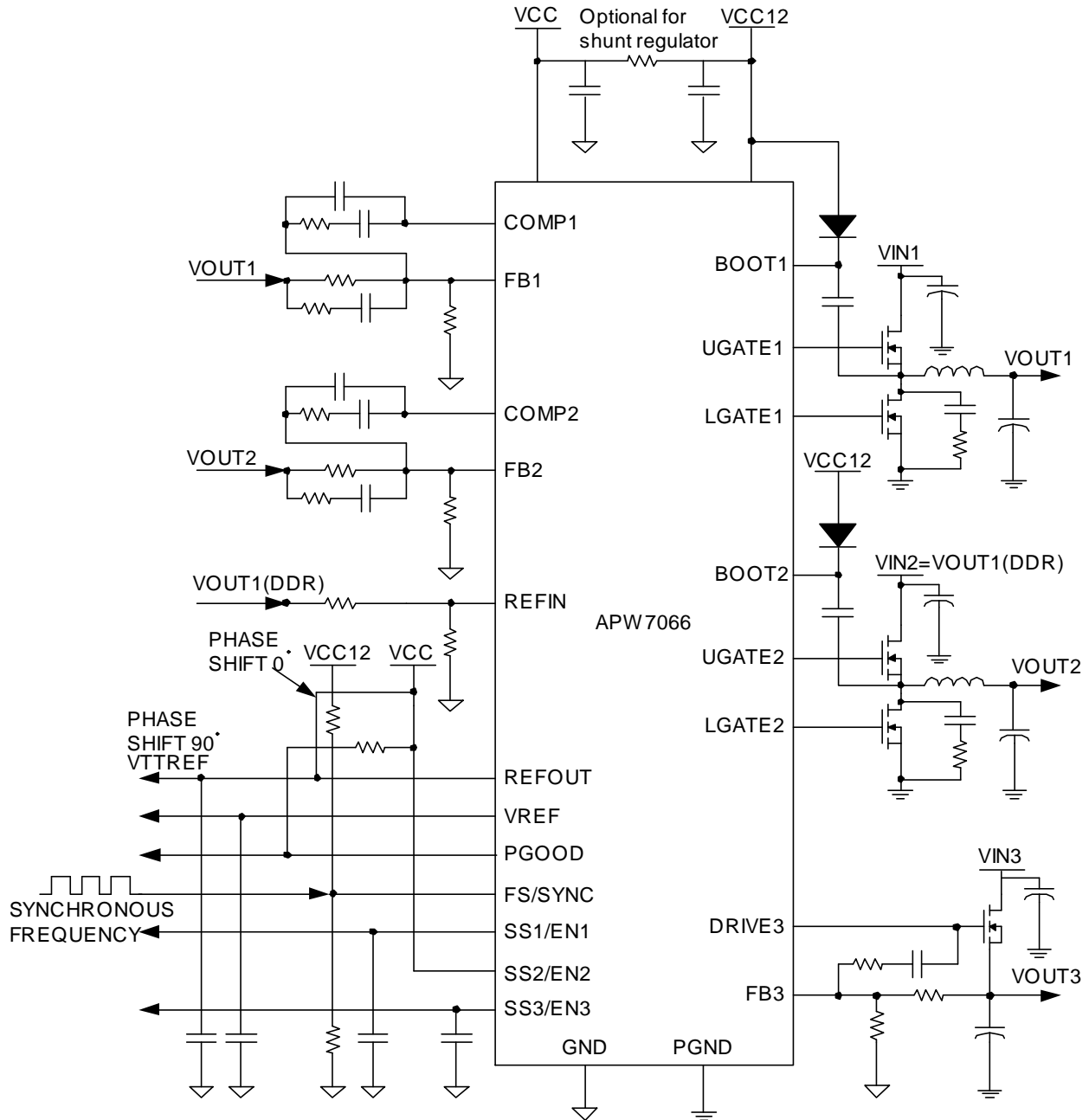

Typical Application Circuit (Cont.)

APW7066  
INDEPENDENT MODE

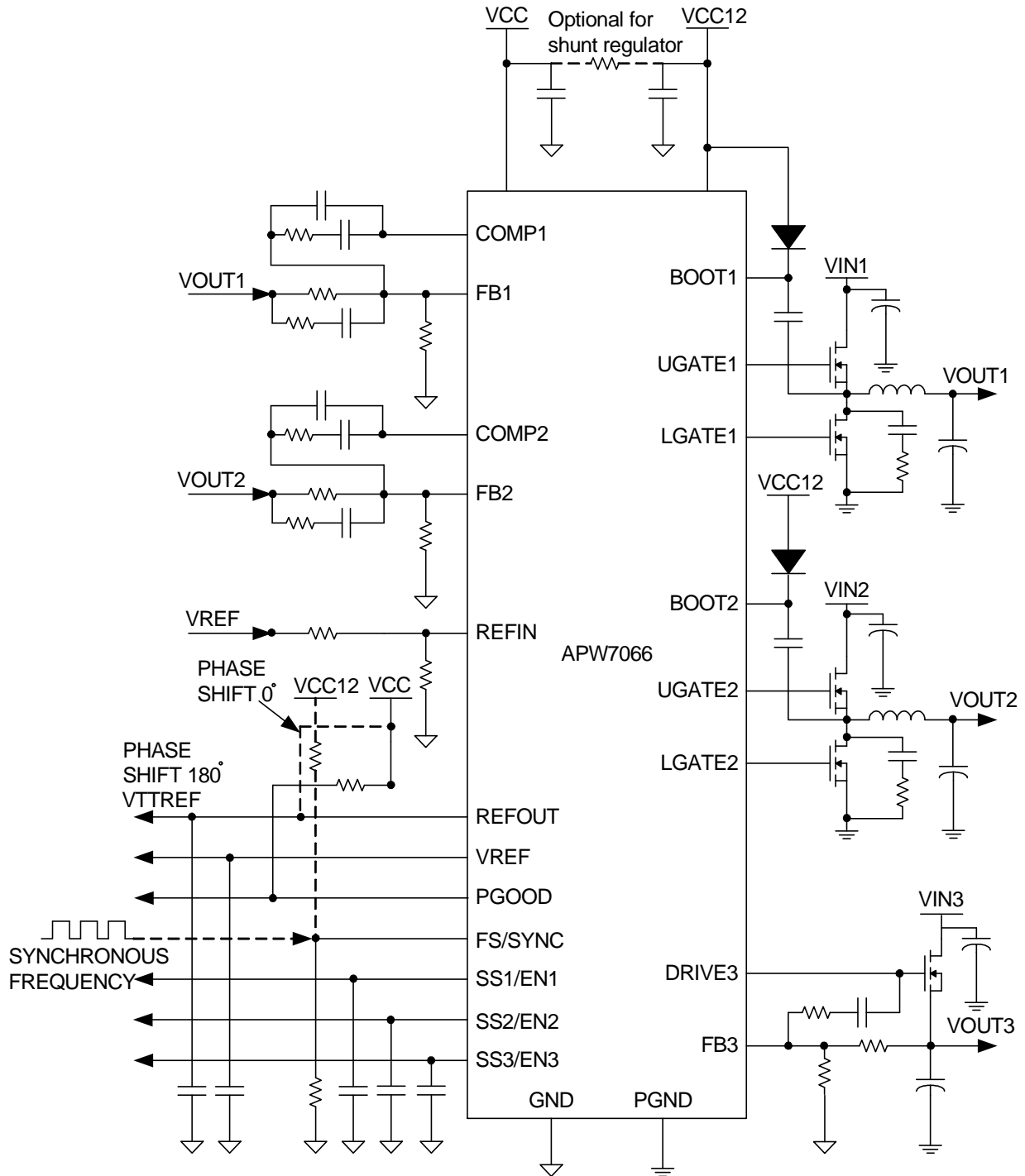



## Function Pin Description

### VCC

Power supply input pin. Connect a nominal 5V power supply to this pin for the control circuit, or connect a resistor (nominally 300Ω) to VCC12 for a shunt regulator function (typical 5.8V). It is recommended that a decoupling capacitor (1 to 10uF) is connected to the GND for noise decoupling.

### GND

This pin is the signal ground pin. The metal thermal pad under the package is the IC substrate; connects the GND pin and metal thermal pad together on the board, and ties to the good GND plane for electrical and thermal conduction.

### VCC12

Power supply input pin. Connect a nominal 12V power supply to this pin for the gate driver. It is recommended that a decoupling capacitor (1 to 10uF) is connected to the GND for noise decoupling.

### PGND

This pin is the power ground pin for the gate driver and linear driver circuit. It should be tied to the GND.

### FB1, FB2, FB3

These pins are the inverting inputs of the error amplifiers of their respective regulators. They are used to set the output voltage and the compensation components.

### SS1/EN1, SS2/EN2, SS3/EN3

These pins provide two functions. Connect a capacitor to the GND for setting the soft-start time. Use an open drain logic signal to pull the SS/EN pin low to disable the respective output, leave open to enable the respective output.

### COMP1, COMP2

These pins are the outputs of error amplifiers of their respective regulators. They are used to set the compensation components.

### UGATE1, UGATE2

These pins provide the gate driver for the upper MOSFETs of VOUT1 and VOUT2.

### LGATE1, LGATE2

These pins provide the gate driver for the lower MOSFETs of VOUT1 and VOUT2.

### BOOT1, BOOT2

These pins provide the bootstrap voltage to the gate driver for driving the upper MOSFETs. It can be connected to a power voltage directly, but the difference voltage between the BOOT and VIN must be high enough to drive the upper MOSFETs.

### REFIN

This pin is the reference input voltage of error amplifier of the VOUT2. It also provides the voltage into a buffer, which is out on the REFOUT pin.

### REFOUT

This pin provides a buffered voltage, which is from REFIN pin. In Independent mode, it can be used by other ICs. In DDR mode, it is from the VOUT1, and can be used as the VTT buffer.

This pin also uses to select the phase shift (see table1). When this pin pulls to VCC, the buffer is disabled and the REFOUT is not available for use. It is recommended that a 0.1uF capacitor is connected to the ground for stability.

### VREF

This pin provides a 3.3V reference voltage, which can be used by the REFIN pin or other ICs as a voltage reference. It is recommended that a 1uF capacitor is connected to ground for stability.

### DRIVE3

This pin drives the gate of an external N-channel MOSFET for linear regulator.

### PGOOD

This pin is an open drain device; connect a pull up resistor to the VCC for PGOOD function.

### FS/SYNC

This pin is used to adjust the switching frequency. Connecting a resistor from FS/SYNC pin to the ground increases the switching frequency. Conversely, connecting a resistor from this pin to the VCC12 reduces the switching frequency. In addition, this pin also provides synchronous frequency function. An external clock can be fed into this pin, and force the switching frequency to follow the external clock.

## Typical Characteristics

VOUT1 Power Up

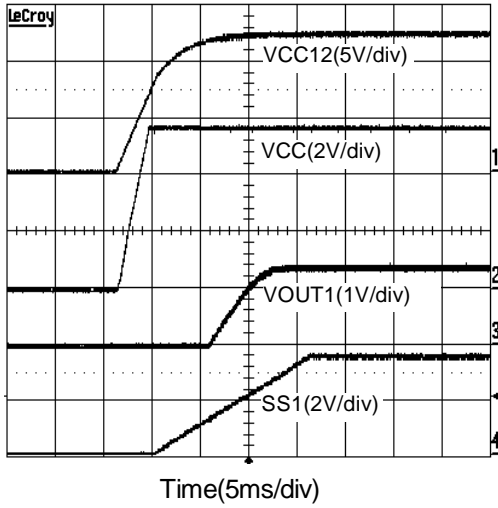

VOUT2 Power Up

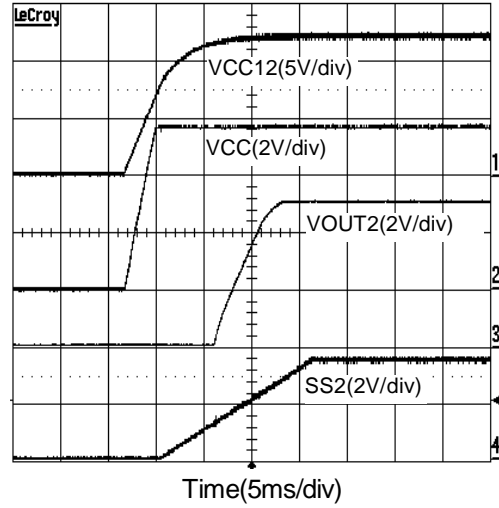

VOUT3 Power Up

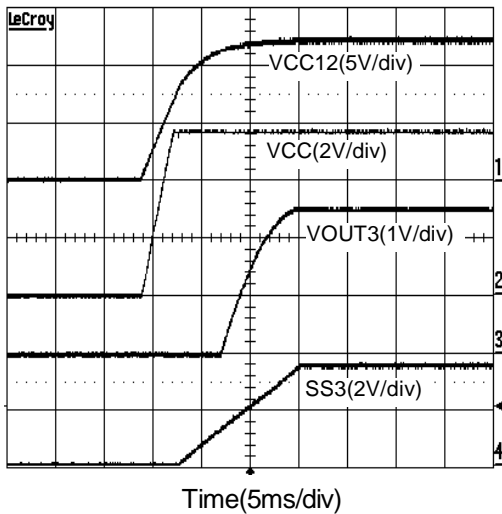

VREF Power Up

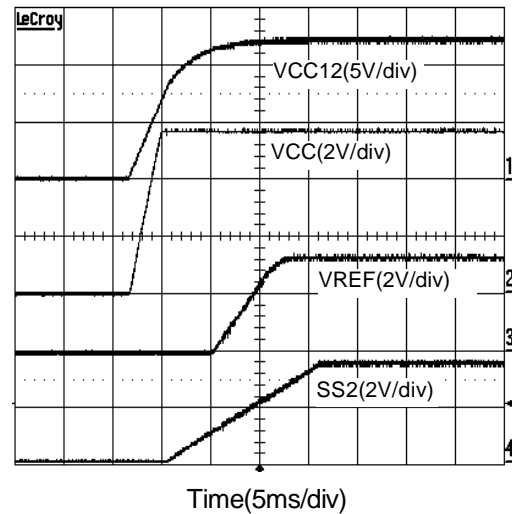

Typical Characteristics (Cont.)

VOUT1 Power Up

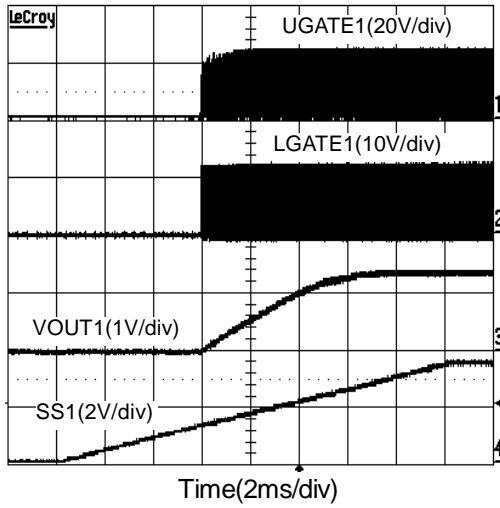

VOUT2 Power Up

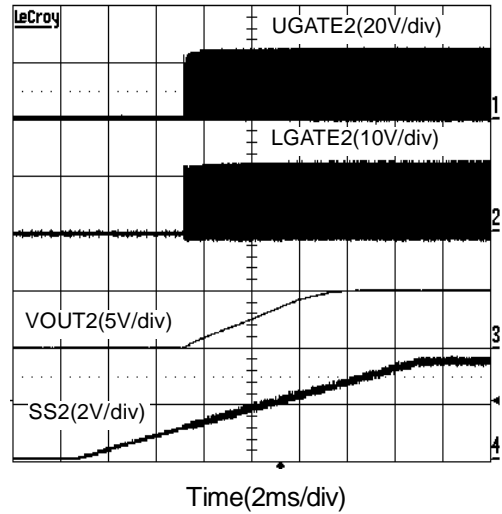

DDR Mode Power Up

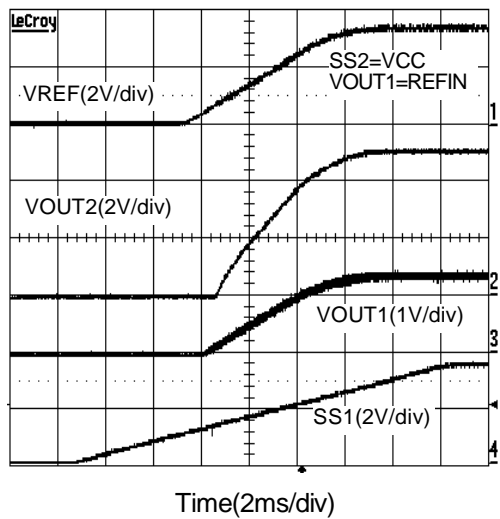

Phase Shift 0 degrees

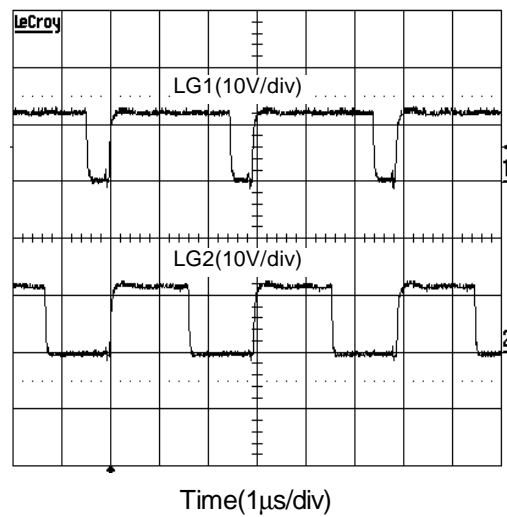

Typical Characteristics (Cont.)

Phase Shift 90 degrees

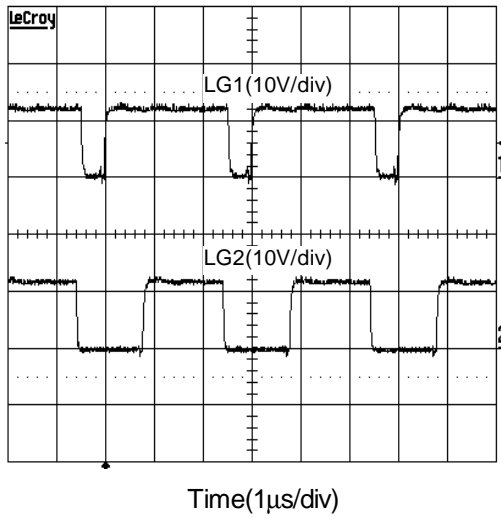

Phase Shift 180 degrees

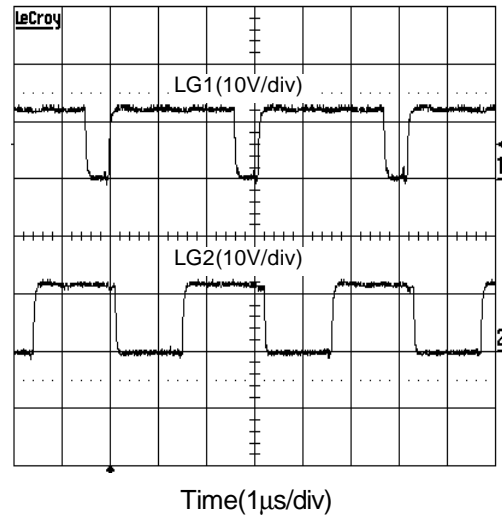

PGOOD High

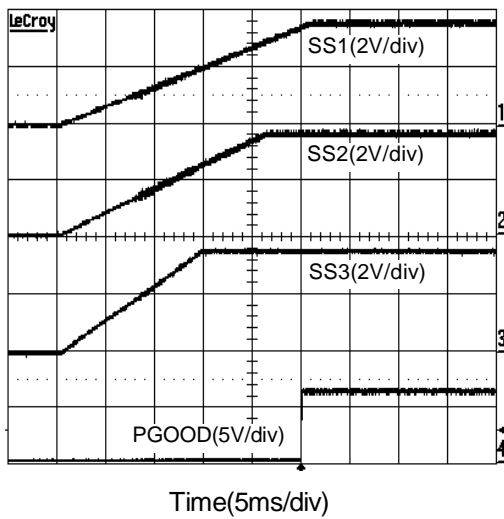

PGOOD Low

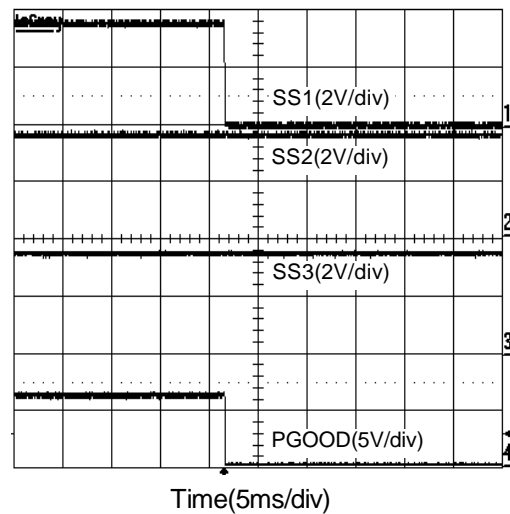

Typical Characteristics (Cont.)

VOUT2 Short Circuit Protection

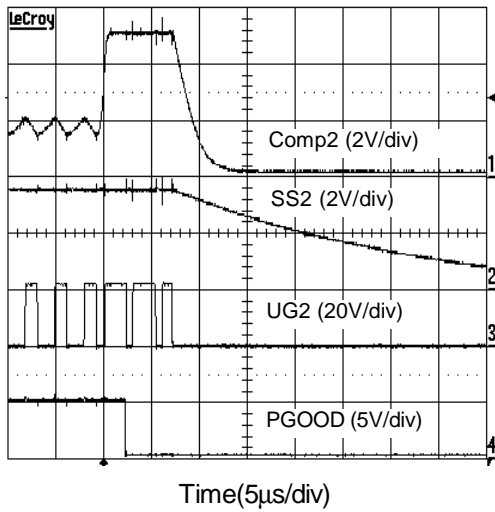

VOUT1 Short Circuit Protection

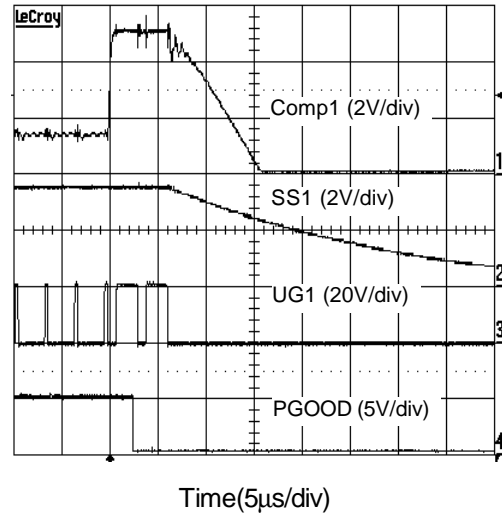

VOUT1 Load Transient

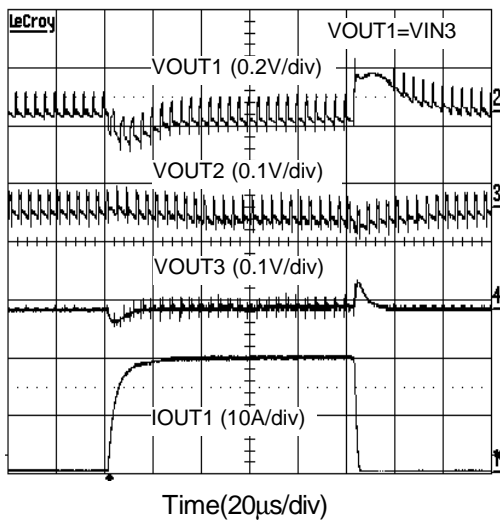

VOUT2 Load Transient

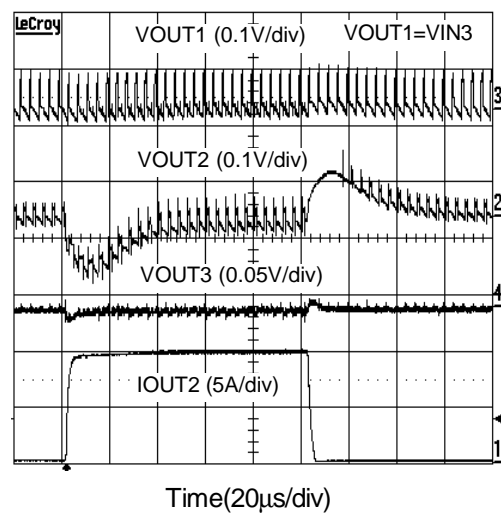

Typical Characteristics (Cont.)

VOUT3 Load Transient

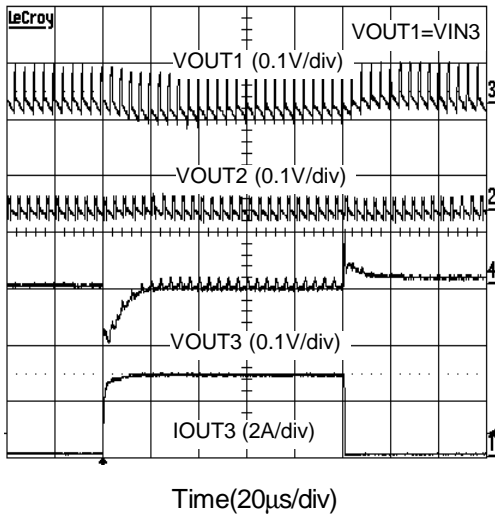

UG1 Rising

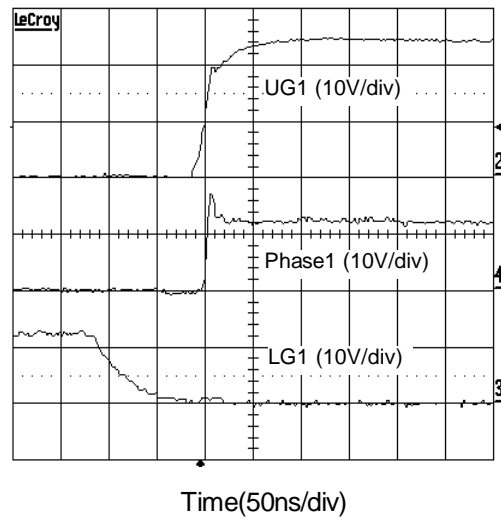

UG1 Falling

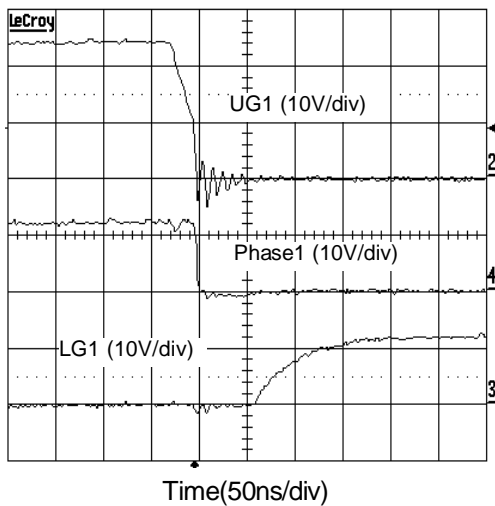

UG2 Rising

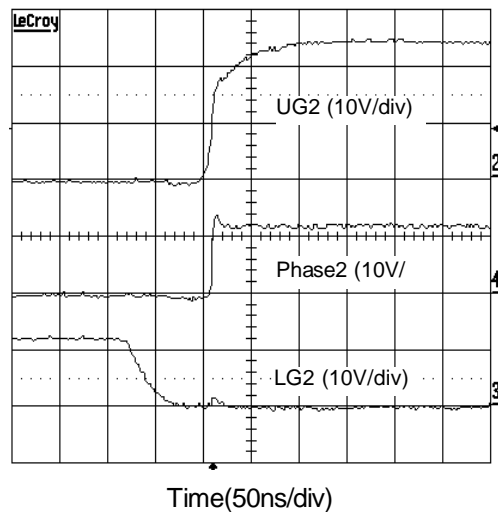

Typical Characteristics (Cont.)

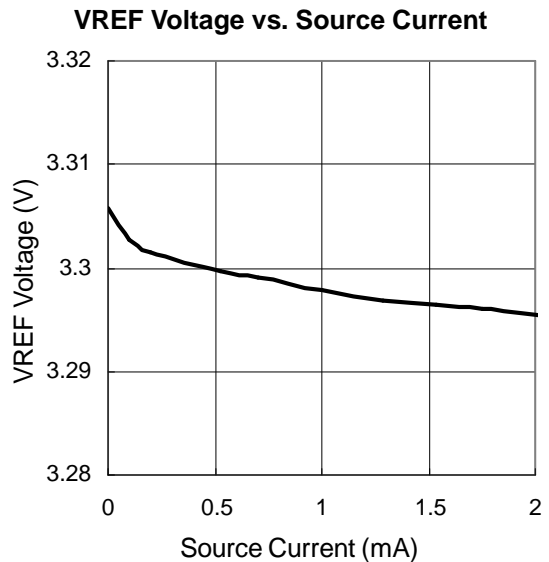
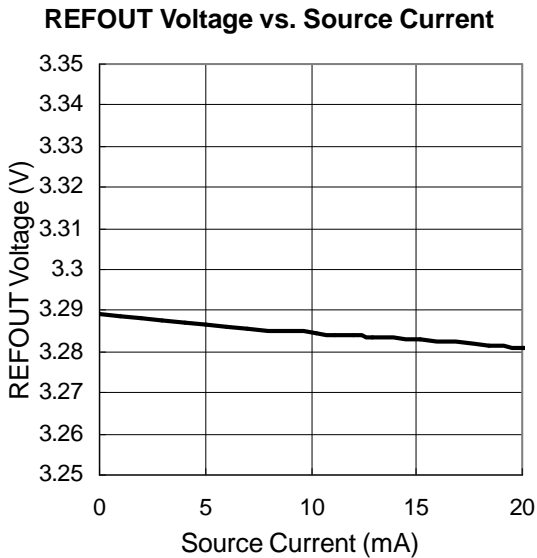
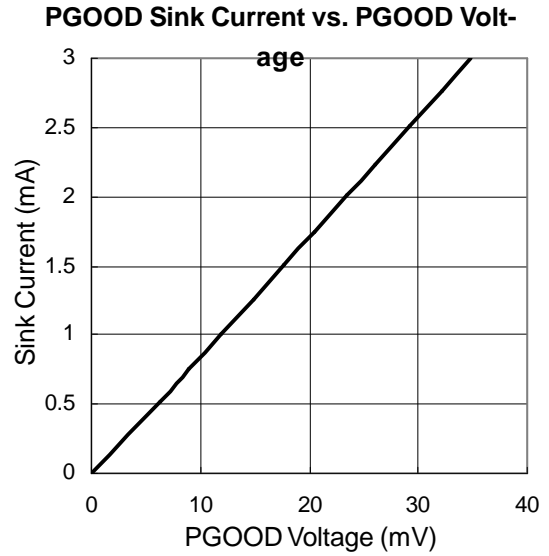
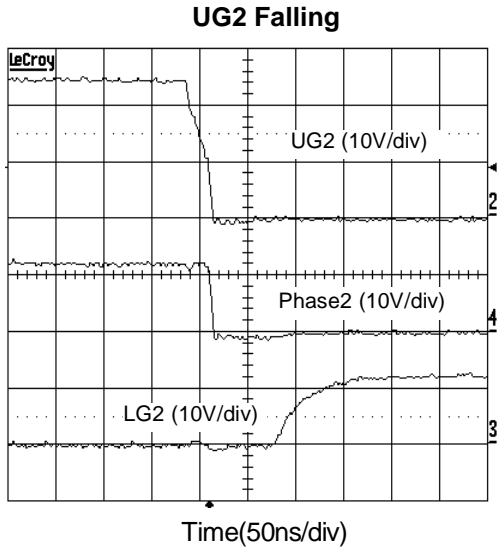

Typical Characteristics (Cont.)

UG1 Sink Current vs. Voltage

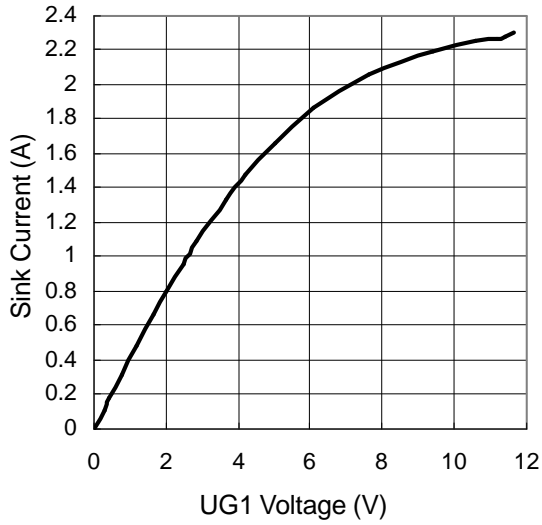

UG1 Source Current vs. Voltage

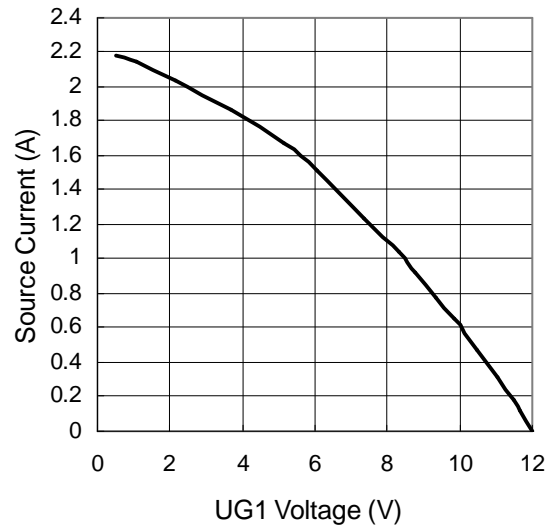

LG1 Sink Current vs. Voltage

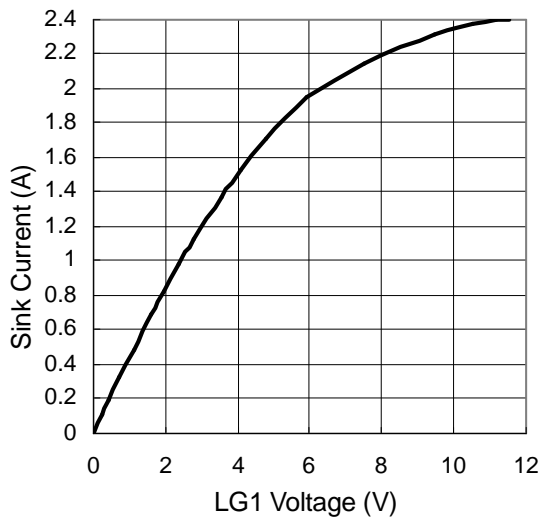

LG1 Source Current vs. Voltage

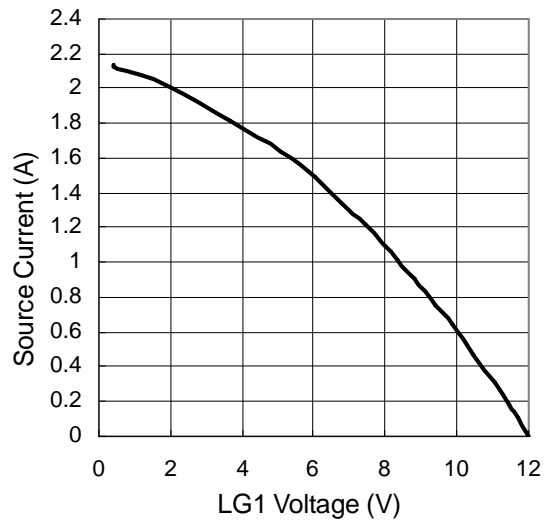



Typical Characteristics (Cont.)

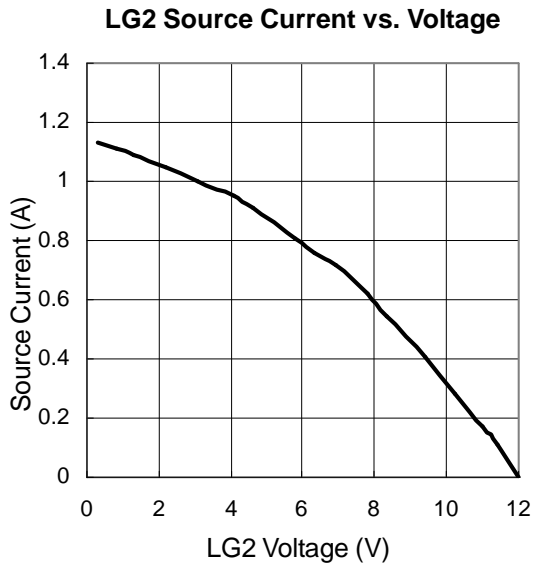
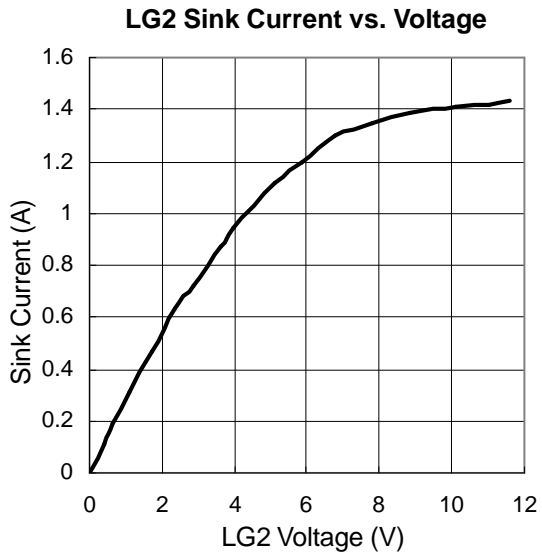
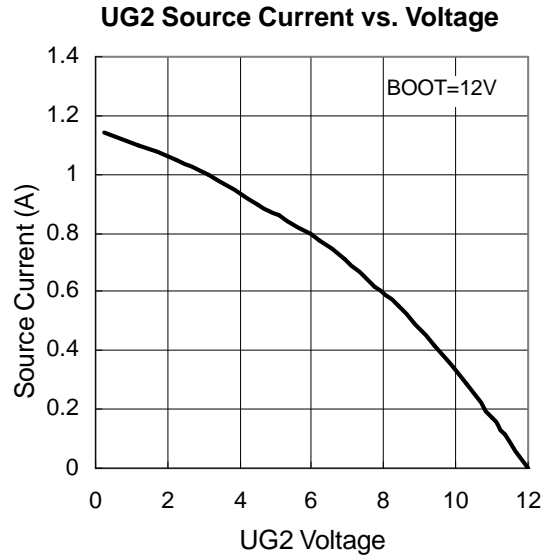
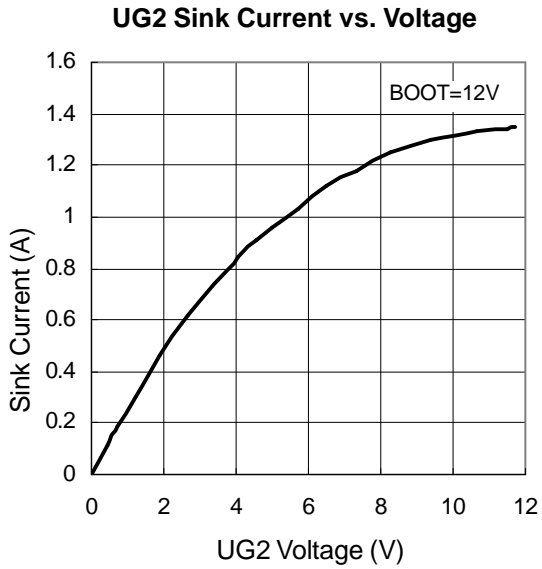

Typical Characteristics (Cont.)

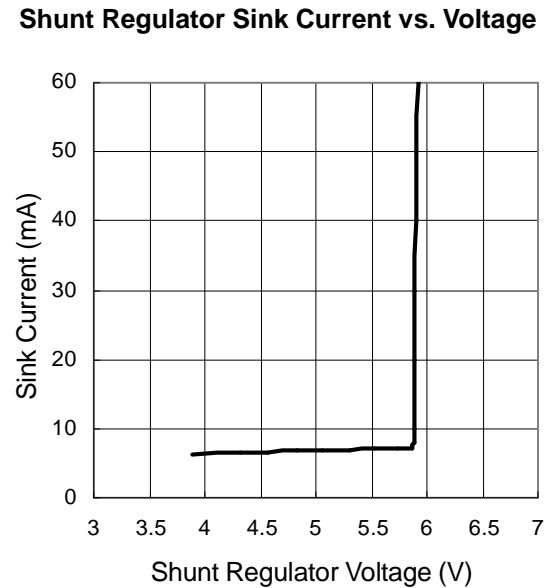
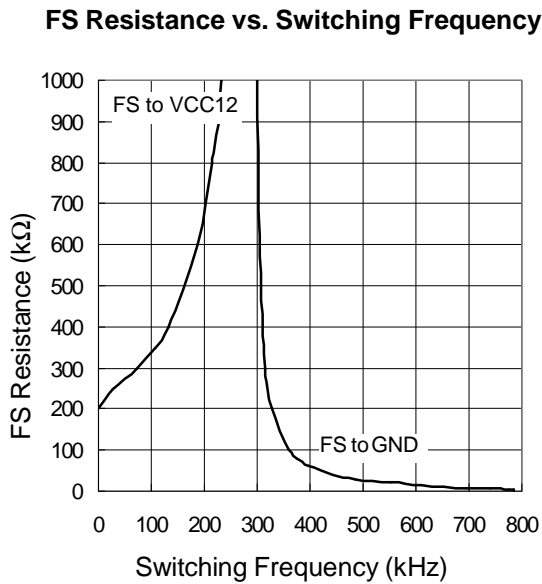
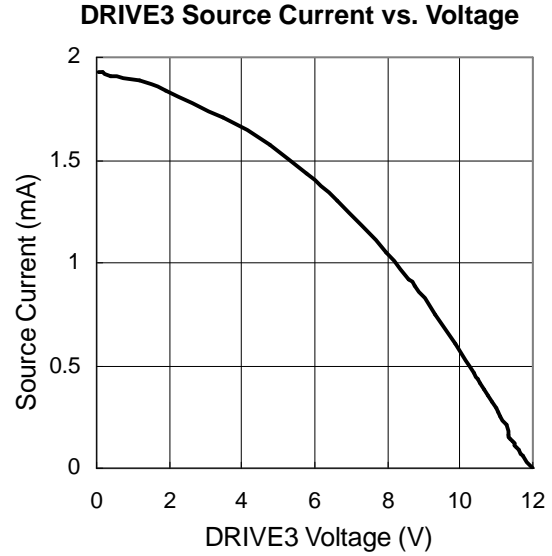
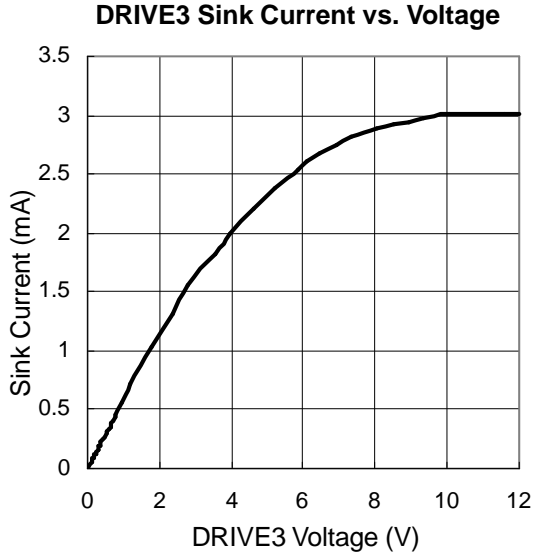

Typical Characteristics (Cont.)

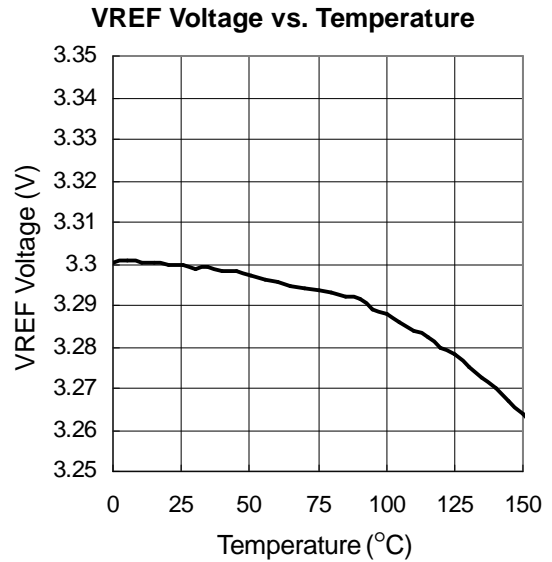
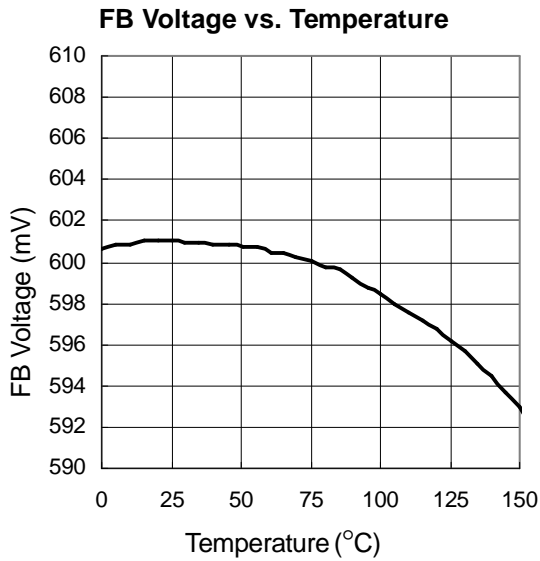
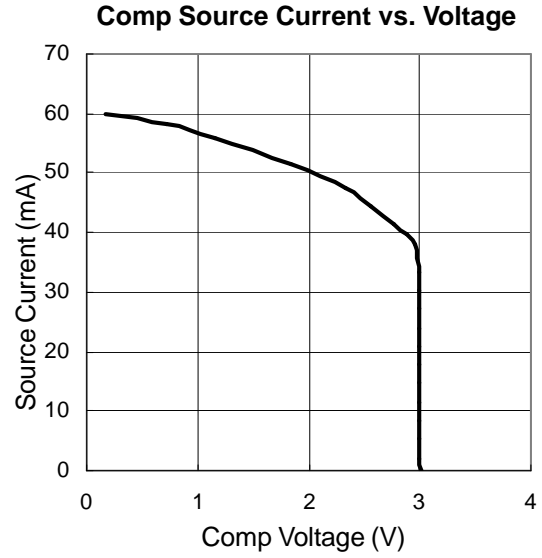
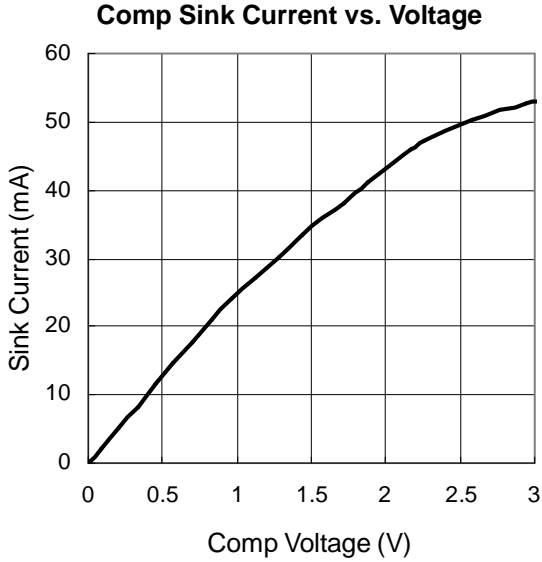

## Function Description

### Operational Modes

The APW7066 has two independent synchronous buck converters, and it also has DDR mode operation to allow VOUT2 to track VOUT1.

In independent mode operation, connect a capacitor from each SS/EN pin to the ground to set each regulator's soft-start time. The 3.3V reference VREF can be used directly, or divided by two resistors for REFIN, since the VREF is controlled by the SS2/EN2.

DDR mode is chosen by connecting the SS2/EN2 pin to VCC(5V). In this mode, SS2/EN2 function will be disabled, SS1/EN1 is used to control soft start and enable both VOUT1 and VOUT2. The VOUT1 is used as the REFIN for the VOUT2, that makes VOUT2 to track VOUT1.

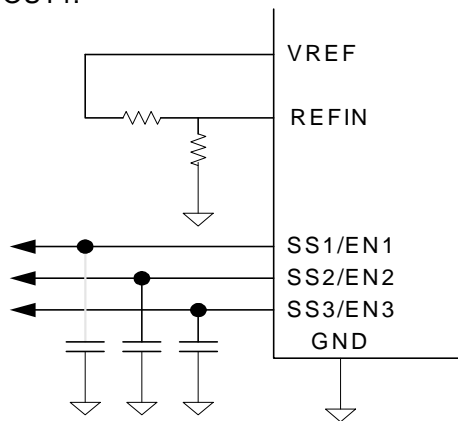

Figure 1. Independent Mode Circuit

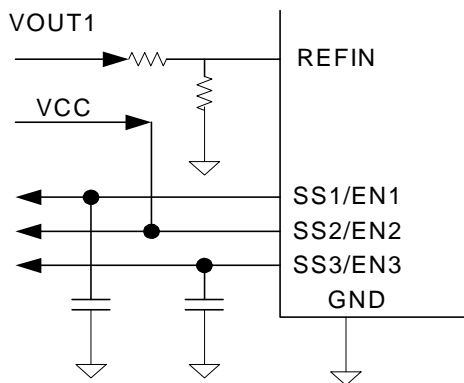

Figure 2. DDR Mode Circuit

### Phase Shift

The APW7066 has phase shift function, use the REFOUT pin to select the phase shift between Independent mode and DDR mode. Connect the REFOUT to VCC to get the 0 degree in either mode. In this case, the buffer of the REFOUT is disabled. Leave the REFOUT open shifts the phase 90 degrees in DDR mode, or 180 degrees in Independent mode, REFOUT can be used in this case ( see Table 1.).

MODE	SS2/EN2	REFOUT	REFIN	PHASE SHIFT	CH1/CH2
DDR	VCC	VCC	VOUT1	0 deg	SS1/EN1 for CH1 and CH2
DDR	VCC	Open	VOUT1	90 deg	
Independent	SS2 cap	VCC	VREF	0 deg	SS1/EN1 for CH1 SS2/EN2 for CH2
Independent	SS2 cap	Open	VREF	180 deg	

Table1. Mode and Phase Selection

The advantage of Phase shift is to avoid overlapping the switching current spikes of the two channels, or interaction between the channels; it also reduces the RMS current of the input capacitors, allowing fewer caps to be employed. However, the phase shift between the rising edge of LGATE1 and LGATE2 (See figure 3.), depending on the duty cycles, the falling edges of the two channels might overlap; so the user should check it.

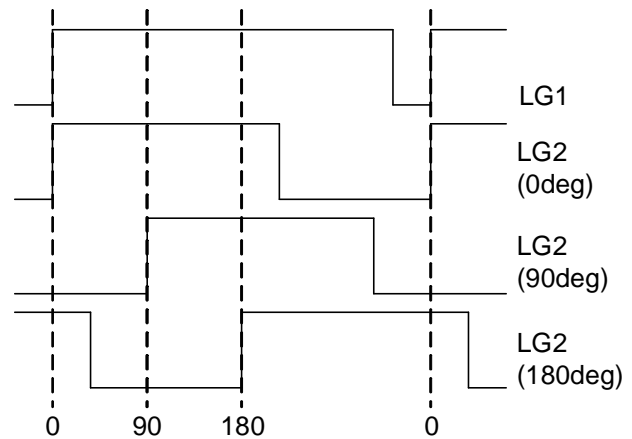

Figure 3. Phase of LG2 with respect to rising edge of LG1

## Function Description (Cont.)

### Soft-Start/Enable

The three SS/EN pins control the soft-start and enable or disable the controller. In Independent mode, the three regulators all have independent soft-start and enable functions. Connect a soft-start capacitor from each SS/EN pin to the GND to set the soft-start interval, and an open drain logic signal for each SS/EN pin will enable or disable the respective output.

Figure 4. Shows the soft-start interval. When both VCC and VCC12 reach their Power-On-Reset threshold 4.23V and 7.8V, a 30 $\mu$ A current source starts to charge the capacitor. When the SS reaches the enabled threshold about 1V, the internal 0.6V reference starts to rise and follows the SS; the error amplifier output (COMP) suddenly raises to 1.1V, which is the valley of the oscillator's triangle wave, leads the VOUT to start up. Until the SS reaches about 3.0V, the internal reference completes the soft-start interval and reaches to 0.6V; then VOUT1 is in regulation. The SS1 still rises to 3.5V and then stops.

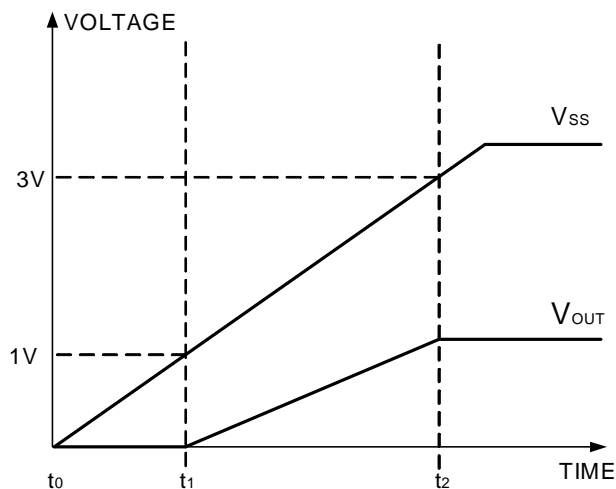

Figure 4. Soft-Start Interval

$$T_{\text{Soft-Start}} = t_2 - t_1 = \frac{C_{\text{SS}} \cdot 2V}{I_{\text{SS}}}$$

Where:

$C_{\text{SS}}$  = external Soft-Start capacitor

$I_{\text{SS}}$  = Soft-Start current = 30 $\mu$ A

### PGOOD

The PGOOD output is an open-drain device, when the VCC is present; the gate of open-drain device will be high, forcing the PGOOD pin to go low. The three SS/EN pins and the SCP signals control the PGOOD signal (see block diagram), after the three SS/EN signals are over threshold high 3.3V and three outputs have no short-circuit, the PGOOD goes high to indicate all regulators are ready. If any of the SS/EN pins goes below threshold low 3.2V, the PGOOD will go low. Also, if any of the outputs has a short, the PGOOD pull low and if short-circuit condition continues for 1-2 clock pulses, all regulators will shut down. If the short-circuit is not long enough to shut down, it may still cause PGOOD to go low momentarily.

Because the PGOOD is an open-drain device, the typical range of the value to connect a pull high resistor to VCC will be 1k $\Omega$  to 10k $\Omega$ ; if PGOOD is not used, leave it open.

### Shunt Regulator

The APW7066 must have two power supplies VCC (5V) and VCC12 (12V) to drive the IC; VCC (5V) is for the control circuit and VCC12 (12V) is for the drivers of outputs. But it can also operate only VCC12, because the shunt regulator 5.8V was designed for VCC (5V); the range of the shunt regulator was designed over the usual range 4.5V to 5.5V of typical 5V power supplies.

Connect a resistor from VCC12 to VCC for shunt regulator and for the supply current. The input supply current of VCC is 7mA; minimum shunt regulator current is about 7mA, and therefore the 20mA shunt regulator current is enough; thus, the typical value, 300  $\Omega$  of the resistor is recommended. The relation among minimum shunt regulator current, required shunt regulator current and supply current is:

## Function Description (Cont.)

### Shunt Regulator (Cont.)

$$I_{SHUNT} = I_{CC} + I_{SHUNT(MIN)}$$

Where:

$I_{SHUNT}$  = Required Shunt Regulator Current

$I_{CC}$  = Supply Current

$I_{SHUNT(MIN)}$  = Minimum Shunt Regulator Current

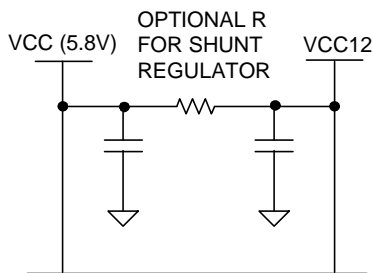

### Oscillator

The APW7066 provides the oscillator switching frequency adjustment. Connect a resistor from FS/SYNC pin to the ground, the nominally 300kHz oscillator switching frequency is increased according to the value of the resistor. The adjustment range of the switching frequency is 300kHz to 800kHz.

Conversely, connecting a resistor from FS/SYNC pin to the VCC12 reduces the switching frequency. The adjustment range of the switching frequency is 70kHz to 300kHz.

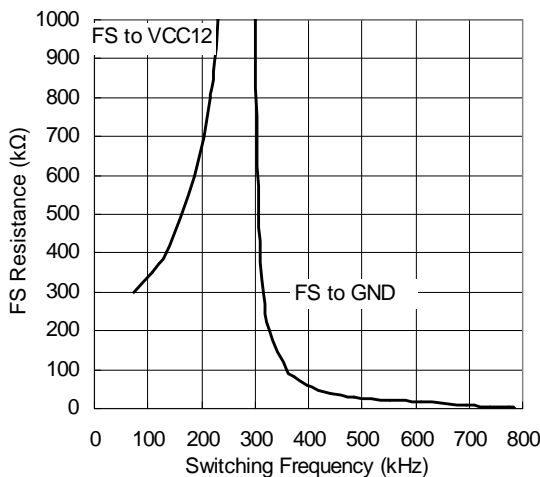

Figure 5. FS/SYNC Resistance vs. Frequency

### SYNC

The switching frequency also can be synchronized to an external frequency. If there are two switching converters on the same board, taking the LGATE signal from another switching converter, go through a 10kΩ resistor, and connecting to the FS/SYNC pin (see Figure 6). Figure 7 shows the switching timing of the synchronization function. The rising edge of external signal and the falling edge of UGATE of APW7066 are fixed; there is a delay time between the rising edge of external signal and the falling edge of UGATE, the delay time is about 500ns. Figure 8 shows the timing chart of the synchronization function. An external signal is connected to the FS/SYNC pin and the switching frequency of APW7066 will track the frequency of external signal after an additional 300us delay time to avoid false triggering. If another converter's signal is lost, the APW7066 will return to internal oscillator. This allows the two switching converters operating at the same frequency to avoid the interference from the independent frequencies between them. The acceptable frequency is a range of 150kHz to 800kHz.

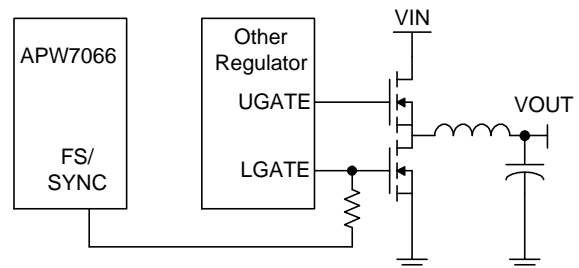

Figure 6. Connecting the LGATE signal from other regulator to FS/SYNC pin

## Function Description (Cont.)

### SYNC (Cont.)

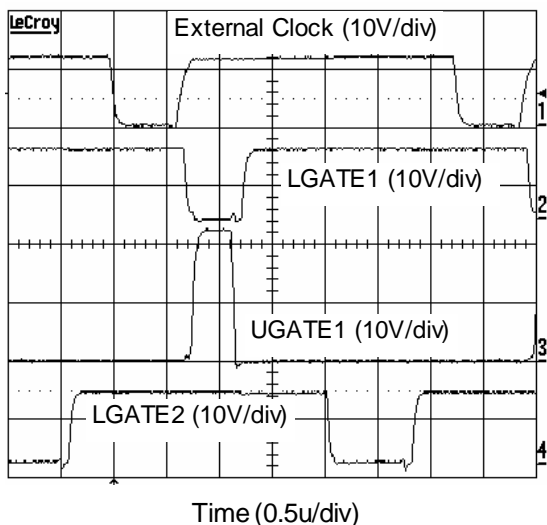

Figure7. The switching timing of synchronization function

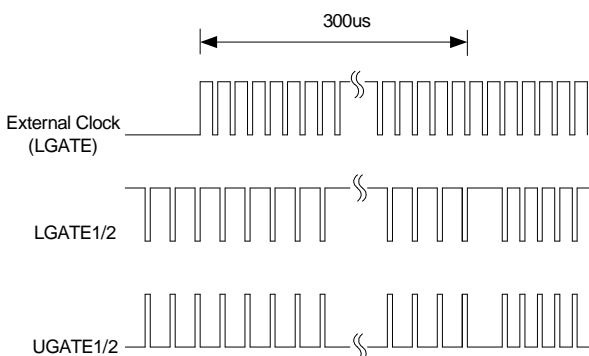

Figure 8. The timing chart of synchronization function

### Short-Circuit Protection

The APW7066 has a simple short-circuit protection to monitor COMP1 and COMP2 for VOUT1/2. When output voltage has a short, the FB pin should start to follow output, since it is a resistor divider from the output. The FB is the inverting input of Error-Amp, when FB pin is lower than the Error-Amp reference, then the COMP will rise to increase the duty-cycle of

the upper MOSFET gate driver, this allows output to get higher voltage. If the short-circuit condition is long enough, the COMP pin will exceed the trip point 3.3V, and the duty circle will hit the maximum. This means that either Over-Current or Under-Voltage condition is detected. If any of the COMP1 and COMP2 exceeds their trip points, and holds over a filter time (1-2 clock cycle of switching frequency), then all regulators will shut down, and require a POR on either of VCC or VCC12 to restart. Note that the linear regulator has no short-circuit protection.

### Output Voltage Setting

The output voltage can be adjusted with a resistive divider, from output voltage to FB pin to the ground. Use 1% or better resistors for these resistor dividers is recommended. The reference voltages of VOUT1 and VOUT3 are 0.6V, the reference voltage of VOUT2 is REFIN voltage. The VREF voltage is for REFIN in independent mode. The following equations can be used to calculate the output voltage:

$$VOUT1 = \left(1 + \frac{R1}{R2}\right) \times 0.6V$$

$$VOUT2 = \left(1 + \frac{R1}{R2}\right) \times REFIN$$

$$VOUT3 = \left(1 + \frac{R1}{R2}\right) \times 0.6V$$

$$REFIN = \left(1 + \frac{R3}{R4}\right) \times VOUT1(DDRMMode)$$

$$REFIN = \left(1 + \frac{R3}{R4}\right) \times VREF(Independent Mode)$$

Where:

- R1 = resistor from VOUT to FB
- R2 = resistor from FB to GND
- R3 = resistor from VREF or VOUT1 to REFIN
- R4 = resistor from REFIN to GND

Note that the R1 is part of the compensation. It should be conformed to the feedback compensation.

## Application Information

### Linear Regulator Input/Output Capacitor Selection

The input capacitor is chosen based on its voltage rating. Under load transient condition, the input capacitor will momentarily supply the required transient current. The output capacitor for the linear regulator is chosen to minimize any droop during load transient condition. In addition, the capacitor is chosen based on its voltage rating.

### Linear Regulator Input/Output MOSFET Selection

The maximum DRIVE3 voltage is determined by the VCC12. Since this pin drives an external N-channel MOSFET, therefore the maximum output voltage of the linear regulator is dependent upon the  $V_{GS}$ .

$$V_{OUT3MAX} = VCC12 - V_{GS}$$

Another criteria is its efficiency of heat removal. The power dissipated by the MOSFET is given by:

$$P_{diss} = I_{out} \times (V_{IN} - V_{OUT3})$$

where  $I_{out}$  is the maximum load current  $V_{OUT3}$  is the nominal output voltage

In some applications, heatsink might be required to help maintain the junction temperature of the MOSFET below its maximum rating.

### Linear Regulator Compensation Selection

The linear regulator is stable over all load current. However, the transient response can be further enhanced by connecting a RC network between the FB3 and DRIVE3 pin. Depending on the output capacitance and load current of the application, the value of this RC network is then varied. A good starting point for the resistor value is 6.8k $\Omega$  and 470pF for the capacitor.

### PWM Compensation

The output LC filter of a step down converter introduces

a double pole, which contributes with -40dB/decade gain slope and 180 degrees phase shift in the control loop. A compensation network between COMP, FB and VOUT should be added. The compensation network is shown in Fig. 12.

The output LC filter consists of the output inductor and output capacitors. The transfer function of the LC filter is given by:

$$GAIN_{LC} = \frac{1 + s \times ESR \times C_{OUT}}{s^2 \times L \times C_{OUT} + s \times ESR \times C_{OUT} + 1}$$

The poles and zero of this transfer function are:

$$F_{LC} = \frac{1}{2 \times \pi \times \sqrt{L \times C_{OUT}}}$$

$$F_{ESR} = \frac{1}{2 \times \pi \times ESR \times C_{OUT}}$$

The  $F_{LC}$  is the double poles of the LC filter, and  $F_{ESR}$  is the zero introduced by the ESR of the output capacitor.

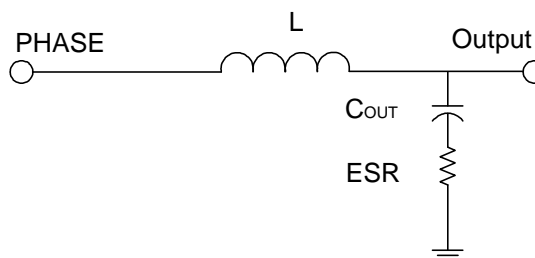

Figure 9. The Output LC Filter

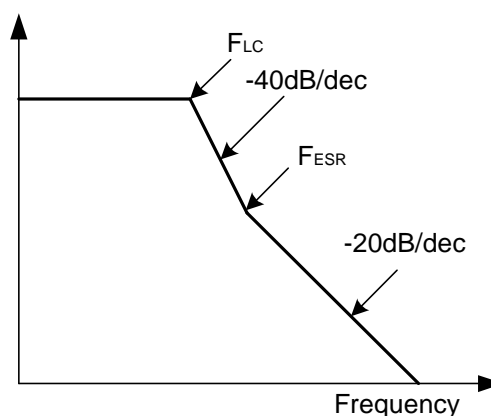

Figure 10. The LC Filter Gain & Frequency



## Application Information (Cont.)

### PWM Compensation (Cont.)

The PWM modulator is shown in Figure 11. The input is the output of the error amplifier and the output is the PHASE node. The transfer function of the PWM modulator is given by:

$$GAIN_{PWM} = \frac{V_{IN}}{\Delta V_{OSC}}$$

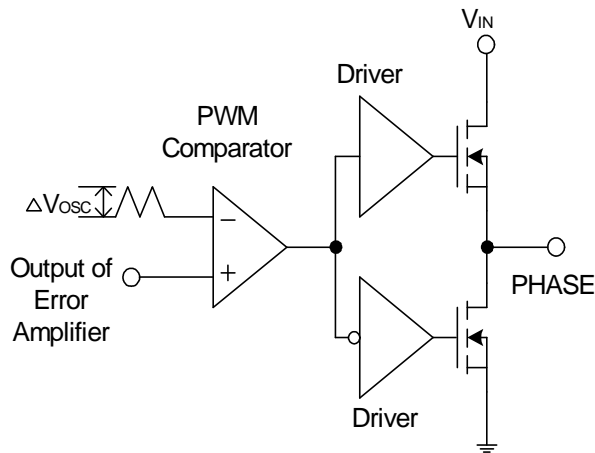

Figure 11. The PWM Modulator

The compensation circuit is shown in Figure 12. It provide a close loop transfer function with the highest zero crossover frequency and sufficient phase margin.

The transfer function of error amplifier is given by:

$$GAIN_{AMP} = \frac{V_{COMP}}{V_{OUT}} = \frac{\frac{1}{sC1} // \left( R2 + \frac{1}{sC2} \right)}{R1 // \left( R3 + \frac{1}{sC3} \right)}$$

$$= \frac{R1+R3}{R1 \times R3 \times C1} \times \frac{\left( s + \frac{1}{R2 \times C2} \right) \times \left( s + \frac{1}{(R1+R3) \times C3} \right)}{s \left( s + \frac{C1+C2}{R2 \times C1 \times C2} \right) \times \left( s + \frac{1}{R3 \times C3} \right)}$$

The poles and zeros of the transfer function are:

$$F_{Z1} = \frac{1}{2 \times \pi \times R2 \times C2}$$

$$F_{Z2} = \frac{1}{2 \times \pi \times (R1+R3) \times C3}$$

$$F_{P1} = \frac{1}{2 \times \pi \times R2 \times \left( \frac{C1 \times C2}{C1 + C2} \right)}$$

$$F_{P2} = \frac{1}{2 \times \pi \times R3 \times C3}$$

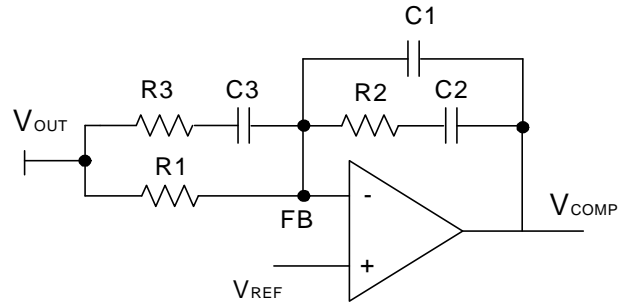

Figure 12. Compensation Network

The closed loop gain of the converter can be written as:

$$GAIN_{LC} \times GAIN_{PWM} \times GAIN_{AMP}$$

Figure 13. shows the asymptotic plot of the closed loop converter gain and the following guidelines will help to design the compensation network. Using the below guidelines should give a compensation similar to the curve plotted. A stable closed loop has a -20dB/decade slope and a phase margin greater than 45 degree.

1. Choose a value for R1, usually between 1K and 5K.
2. Select the desired zero crossover frequency Fo:  $(1/5 \sim 1/10) \times F_s > F_o > F_{ESR}$

Use the following equation to calculate R2:

$$R2 = \frac{\Delta V_{OSC}}{V_{IN}} \times \frac{F_o}{F_{LC}} \times R1$$

3. Place the first zero Fz1 before the output LC filter double pole frequency FLC.

$$F_{Z1} = 0.75 \times F_{LC}$$

Calculate the C2 by the equation:

$$C2 = \frac{1}{2 \times \pi \times R2 \times F_{LC} \times 0.75}$$

4. Set the pole at the ESR zero frequency FESR:

$$F_{P1} = F_{ESR}$$

Calculate the C1 by the equation:

$$C1 = \frac{C2}{2 \times \pi \times R2 \times C2 \times F_{ESR} - 1}$$

## Application Information (Cont.)

### PWM Compensation (Cont.)

5. Set the second pole  $F_{P2}$  at half the switching frequency and also set the second zero  $F_{Z2}$  at the output LC filter double pole  $F_{LC}$ . The compensation gain should not exceed the error amplifier open loop gain, check the compensation gain at  $F_{P2}$  with the capabilities of the error amplifier.

$$F_{P2} = 0.5 \times F_s$$

$$F_{Z2} = F_{LC}$$

Combine the two equations will get the following component calculations:

$$R3 = \frac{R1}{\frac{F_s}{2 \times F_{LC}} - 1} \quad C3 = \frac{1}{\pi \times R3 \times F_s}$$

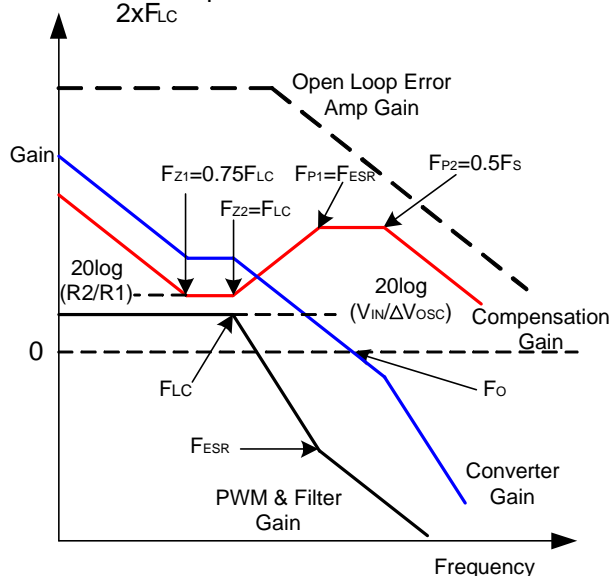

Figure 13. Converter Gain & Frequency

### Output Inductor Selection

The inductor value determines the inductor ripple current and affects the load transient response. Higher inductor value reduces the inductor's ripple current and induces lower output ripple voltage. The ripple current and ripple voltage can be approximated by:

$$I_{RIPPLE} = \frac{V_{IN} - V_{OUT}}{F_s \times L} \times \frac{V_{OUT}}{V_{IN}}$$

$$\Delta V_{OUT} = I_{RIPPLE} \times ESR$$

where  $F_s$  is the switching frequency of the regulator. Although increase the inductor value and frequency reduce the ripple current and voltage, but there is a tradeoff exists between the inductor's ripple current and the regulator load transient response time.

A smaller inductor will give the regulator a faster load transient response at the expense of higher ripple current. Increasing the switching frequency ( $F_s$ ) also reduces the ripple current and voltage, but it will increase the switching loss of the MOSFET and the power dissipation of the converter. The maximum ripple current occurs at the maximum input voltage. A good starting point is to choose the ripple current to be approximately 30% of the maximum output current.

Once the inductance value has been chosen, select an inductor that is capable of carrying the required peak current without going into saturation. In some types of inductors, especially core that is made of ferrite, the ripple current will increase abruptly when it saturates. This will result in a larger output ripple voltage.

### Output Capacitor Selection

Higher Capacitor value and lower ESR reduce the output ripple and the load transient drop. Therefore select high performance low ESR capacitors that are intended for switching regulator applications. In some applications, multiple capacitors have to be parallel to achieve the desired ESR value. A small decoupling capacitor in parallel for bypassing the noise is also recommended, and the voltage rating of the output capacitors are also must be considered. If tantalum capacitors are used, make sure they are surge tested by the manufactures. If in doubt, consult the capacitors manufacturer.

### Input Capacitor Selection

The input capacitor is chosen based on the voltage

## Application Information (Cont.)

### Input Capacitor Selection (Cont.)

rating and the RMS current rating. For reliable operation, select the capacitor voltage rating to be at least 1.3 times higher than the maximum input voltage. The maximum RMS current rating requirement is approximately  $I_{OUT}/2$ , where  $I_{OUT}$  is the load current. During power up, the input capacitors have to handle large amount of surge current. If tantalum capacitors are used, make sure they are surge tested by the manufactures. If in doubt, consult the capacitors manufacturer. For high frequency decoupling, a ceramic capacitor 1uF can be connected between the drain of upper MOSFET and the source of lower MOSFET.

### MOSFET Selection

The selection of the N-channel power MOSFETs are determined by the  $R_{DS(ON)}$ , reverse transfer capacitance ( $C_{RSS}$ ) and maximum output current requirement. The losses in the MOSFETs have two components: conduction loss and transition loss. For the upper and lower MOSFET, the losses are approximately given by the following :

$$P_{UPPER} = I_{out}^2(1+TC)(R_{DS(ON)})D + (0.5)(I_{out})(V_{IN})(t_{sw})F_s$$

$$P_{LOWER} = I_{out}^2(1+TC)(R_{DS(ON)})(1-D)$$

where  $I_{OUT}$  is the load current

TC is the temperature dependency of  $R_{DS(ON)}$

$F_s$  is the switching frequency

$t_{sw}$  is the switching interval

D is the duty cycle

Note that both MOSFETs have conduction losses while the upper MOSFET include an additional transition loss. The switching internal,  $t_{sw}$ , is a function of the reverse transfer capacitance  $C_{RSS}$ .

The (1+TC) term is to factor in the temperature dependency of the  $R_{DS(ON)}$  and can be extracted from

the “ $R_{DS(ON)}$  vs Temperature” curve of the power MOSFET.

### Connecting One Input from Another Output

It can be connected one of the 3 outputs as the input voltage to the 2nd. In these cases the output current of the first output includes its own load current and the 2nd output’s load current. Therefore, the components of the first output must be designed and sized for the both outputs. The soft-start of first output must be faster than the 2nd output. If the first output is not present when the 2nd output tries to start up, the 2nd output cannot get smooth and controlled output voltage rise, even cause short-circuit protection.

### Short Circuit Protection

The APW7066 provides a simple short circuit protection function, and it is not easy to predict its performance, since many factors can affect how well it works. Therefore, the limitations and suggestions of this method must be provided for users to understand how to work it well.

- The short circuit protection was not designed to work for the output in initial short condition. In this case, the short circuit protection may not work, and damage the MOSFETs. If the circuit still works, remove the short can cause an inductive kick on the phase pin, and it may damage the IC and MOSFETs.
- If the resistance of the short is not low enough to cause protection, the regulator will work as the load has increased, and continue to regulate up until the MOSFETs is damaged. The resistance of the short should include wiring, PCB traces, contact resistances, and all of the return paths.
- The higher duty cycle will give a higher COMP voltage level, and it is easy to touch the trip point. The compensation components also affect the

## Application Information (Cont.)

### Short Circuit Protection (Cont.)

response of COMP voltage; smaller caps may give a faster response.

- The output current has faster rising time during short; the COMP pin will have a sharp rise. However, if the current rises too fast, it may cause a false trip. The output capacitance and its ESR can affect the rising time of the current during short.

### Layout Consideration

In high power switching regulator, a correct layout is important to ensure proper operation of the regulator. In general, interconnecting impedances should be minimized by using short, wide printed circuit traces. Signal and power grounds are to be kept separate and finally combined using ground plane construction or single point grounding. Figure 14. illustrates the layout, with bold lines indicating high current paths; these traces must be short and wide. Components along the bold lines should be placed close together. Below is a checklist for your layout :

- The metal plate of the bottom of the packages (TSSOP-24 and QFN-32) must be soldered to the PCB and connected to the GND plane on the backside through several thermal vias.
- Keep the switching nodes (UGATE, LGATE and PHASE) away from sensitive small signal nodes since these nodes are fast moving signals. Therefore, keep traces to these nodes as short as possible.
- The traces from the gate drivers to the MOSFETs (UG1, LG1, UG2, LG2, DRIVE3) should be short and wide.
- Decoupling capacitor, compensation component, the resistor dividers, boot capacitors, and SS capacitors should be close their pins.
- The input capacitor should be near the drain of the upper MOSFET; the output capacitor should be near the loads. The input capacitor GND should be close to the output capacitor GND and the lower MOSFET GND.
- The drain of the MOSFETs (VIN and phase nodes) should be a large plane for heat sinking.

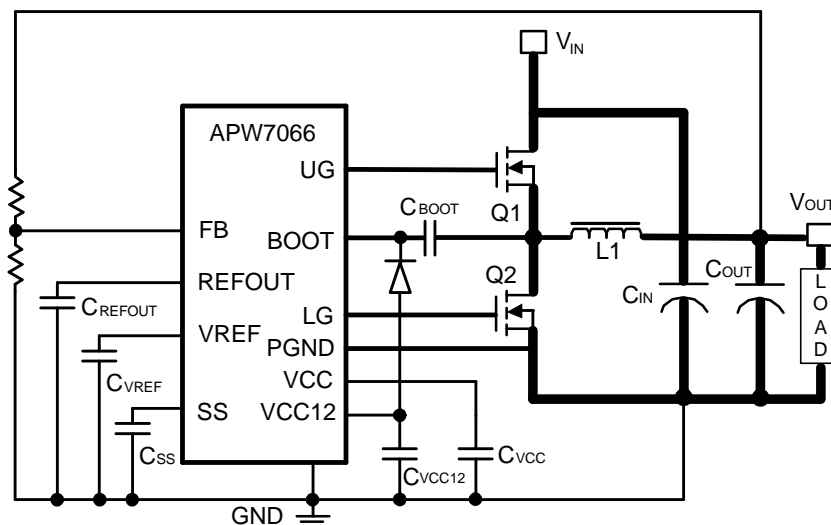
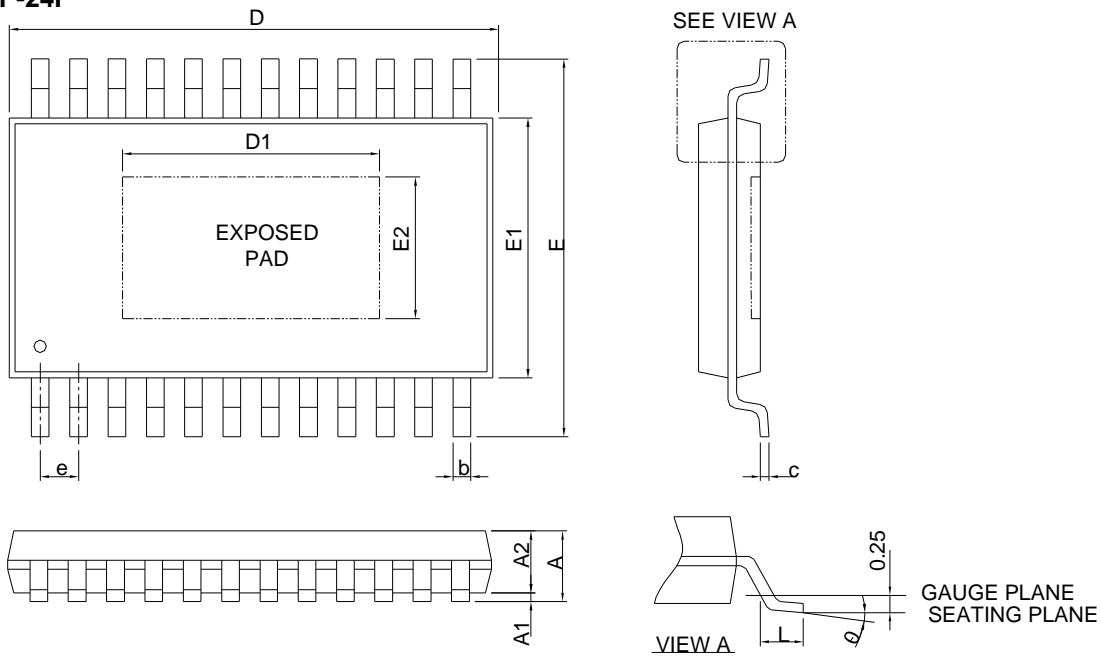

Figure 14. Layout Guidelines

## Package Information

### TSSOP-24P



SYMBOL	TSSOP-24P			
	MILLIMETERS		INCHES	
	MIN.	MAX.	MIN.	MAX.
A		1.20		0.047
A1	0.05	0.15	0.002	0.006
A2	0.80	1.05	0.031	0.041
b	0.19	0.30	0.007	0.012
c	0.09	0.20	0.004	0.008
D	7.70	7.9	0.303	0.311
D1	3.50	6.00	0.138	0.197
E	6.20	6.60	0.244	0.260
E1	4.30	4.50	0.169	0.177
E2	2.50	3.50	0.098	0.138
e	0.65 BSC		0.026 BSC	
L	0.45	0.75	0.018	0.030
theta	0°	8°	0°	8°

Note : 1. Follow JEDEC MO-153 ADT.

2. Dimension "D" does not include mold flash, protrusions or gate burrs. Mold flash, protrusion or gate burrs shall not exceed 6 mil per side.

3. Dimension "E1" does not include inter-lead flash or protrusions. Inter-lead flash and protrusions shall not exceed 10 mil per side.

## Package Information

QFN5x5 -32

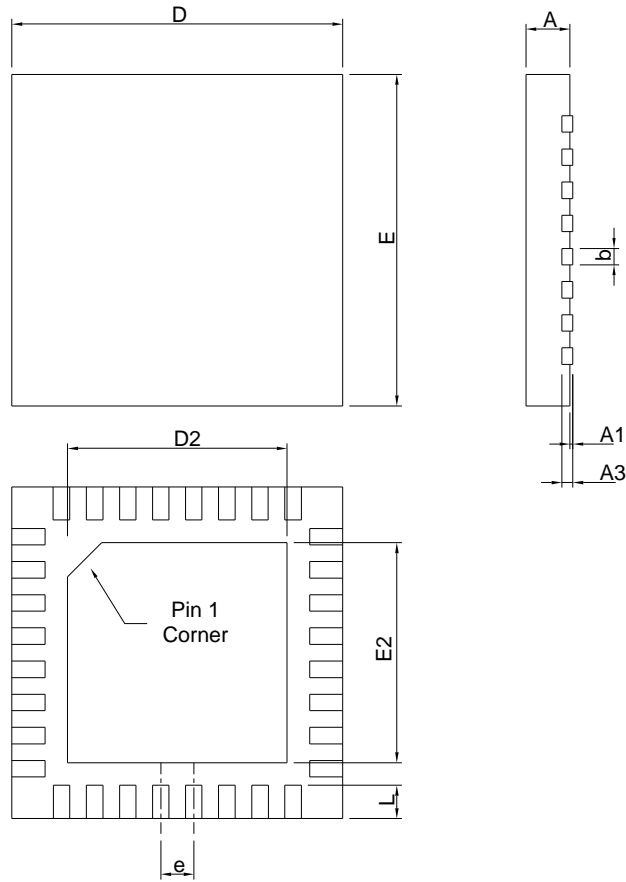

SYMBOL	QFN5x5-32			
	MILLIMETERS		INCHES	
	MIN.	MAX.	MIN.	MAX.
A	0.80	1.00	0.031	0.039
A1	0.00	0.05	0.000	0.002
A3	0.20 REF		0.008 REF	
b	0.18	0.30	0.007	0.012
D	5.00 BSC		0.197 BSC	
D2	3.50	3.80	0.138	0.150
E	5.00 BSC		0.197 BSC	
E2	3.50	3.80	0.138	0.150
e	0.50 BSC		0.020 BSC	
L	0.35	0.45	0.014	0.018

### Carrier Tape & Reel Dimensions

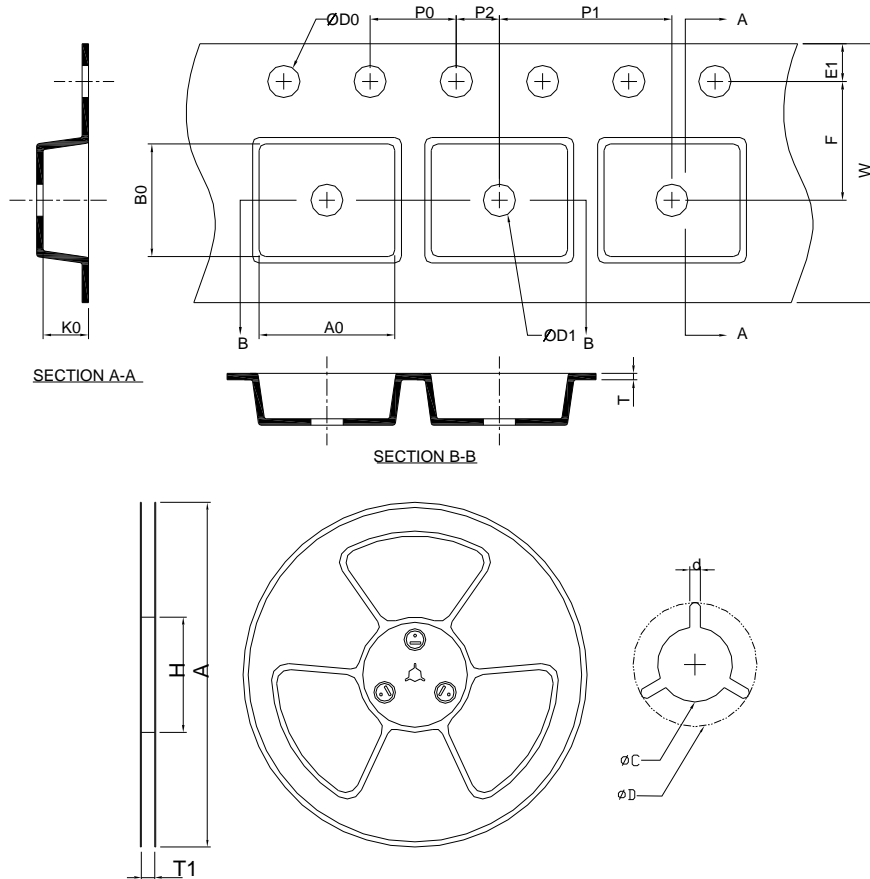

Application	A	H	T1	C	d	D	W	E1	F
QFN 5x5-32	330.0±2.00	50 MIN.	16.4+2.00 -0.00	13.0+0.50 -0.20	1.5 MIN.	20.2 MIN.	12.0±0.30	1.75±0.10	5.5±0.10
	P0	P1	P2	D0	D1	T	A0	B0	K0
	4.0±0.10	12.0±0.10	2.0±0.10	1.5+0.10 -0.00	1.5 MIN.	0.6+0.00 -0.40	5.30±0.20	5.30±0.20	1.30±0.20
Application	A	H	T1	C	d	D	W	E1	F
TSSOP-24P	330.0±2.00	50 MIN.	24.40+2.0 0 -0.00	13.0+0.50 -0.20	1.5 MIN.	20.2 MIN.	16.0±0.30	1.75±0.10	7.50±0.10
	P0	P1	P2	D0	D1	T	A0	B0	K0
	4.00±0.10	12.00±0.10	2.00±0.10	1.5+0.10 -0.00	1.5 MIN.	0.6+0.00 -0.40	6.9±0.20	8.30±0.20	1.60±0.20

(mm)

### Devices Per Unit

Package Type	Unit	Quantity
QFN5x5-32	Tape & Reel	2500
TSSOP-24P	Tape & Reel	2000

**Reflow Condition (IR/Convection or VPR Reflow)**

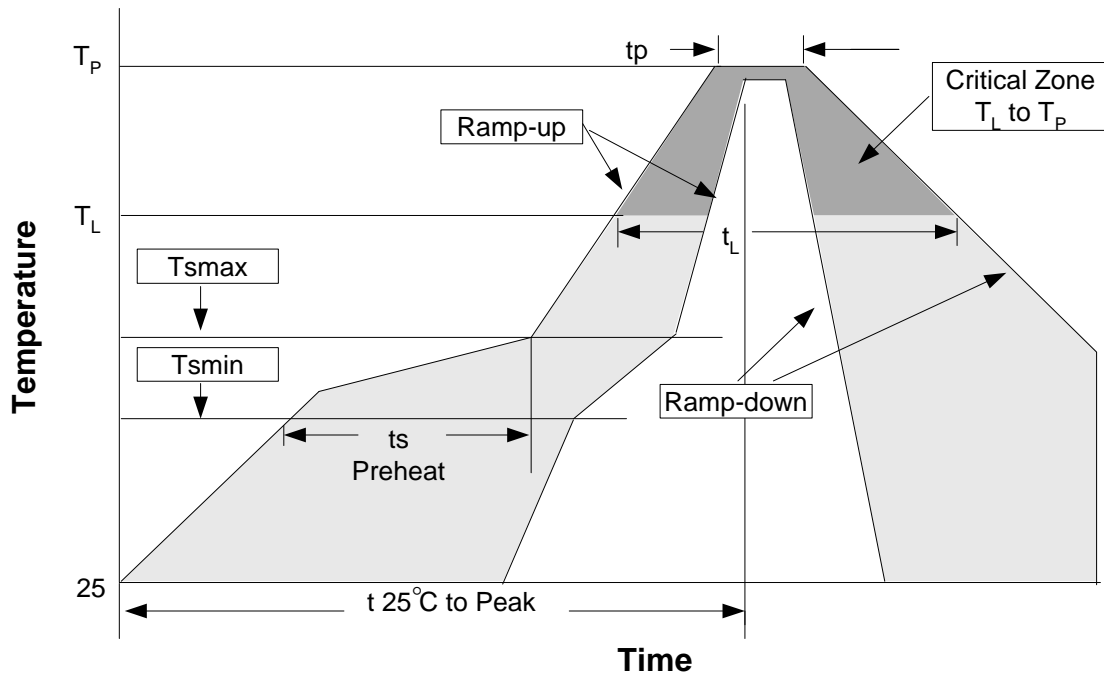

**Reliability Test Program**

Test item	Method	Description
SOLDERABILITY	MIL-STD-883D-2003	245°C, 5 sec
HOLT	MIL-STD-883D-1005.7	1000 Hrs Bias @ 125°C
PCT	JESD-22-B, A102	168 Hrs, 100%RH, 121°C
TST	MIL-STD-883D-1011.9	-65°C~150°C, 200 Cycles
ESD	MIL-STD-883D-3015.7	VHBM > 2KV, VMM > 200V
Latch-Up	JESD 78	10ms, 1 <sub>tr</sub> > 100mA

**Classification Reflow Profiles**

Profile Feature	Sn-Pb Eutectic Assembly	Pb-Free Assembly
Average ramp-up rate (T <sub>L</sub> to T <sub>P</sub> )	3°C/second max.	3°C/second max.
Preheat		
- Temperature Min (T <sub>min</sub> )	100°C	150°C
- Temperature Max (T <sub>max</sub> )	150°C	200°C
- Time (min to max) (t <sub>s</sub> )	60-120 seconds	60-180 seconds
Time maintained above:		
- Temperature (T <sub>L</sub> )	183°C	217°C
- Time (t <sub>L</sub> )	60-150 seconds	60-150 seconds
Peak/Classification Temperature (T <sub>P</sub> )	See table 1	See table 2
Time within 5°C of actual Peak Temperature (t <sub>p</sub> )	10-30 seconds	20-40 seconds
Ramp-down Rate	6°C/second max.	6°C/second max.
Time 25°C to Peak Temperature	6 minutes max.	8 minutes max.

Note: All temperatures refer to topside of the package. Measured on the body surface.



## Classification Reflow Profiles (Cont.)

Table 1. SnPb Eutectic Process – Package Peak Reflow Temperatures

Package Thickness	Volume mm <sup>3</sup> <350	Volume mm <sup>3</sup> ≥350
<2.5 mm	240 +0/-5°C	225 +0/-5°C
≥2.5 mm	225 +0/-5°C	225 +0/-5°C

Table 2. Pb-free Process – Package Classification Reflow Temperatures

Package Thickness	Volume mm <sup>3</sup> <350	Volume mm <sup>3</sup> 350-2000	Volume mm <sup>3</sup> >2000
<1.6 mm	260 +0°C*	260 +0°C*	260 +0°C*
1.6 mm – 2.5 mm	260 +0°C*	250 +0°C*	245 +0°C*
≥2.5 mm	250 +0°C*	245 +0°C*	245 +0°C*

\*Tolerance: The device manufacturer/supplier **shall** assure process compatibility up to and including the stated classification temperature (this means Peak reflow temperature +0°C. For example 260°C+0°C) at the rated MSL level.

## Customer Service

### Anpec Electronics Corp.

Head Office :

No.6, Dusing 1st Road, SBIP,  
Hsin-Chu, Taiwan  
Tel : 886-3-5642000  
Fax : 886-3-5642050

Taipei Branch :

2F, No. 11, Lane 218, Sec 2 Jhongsing Rd.,  
Sindian City, Taipei County 23146, Taiwan  
Tel : 886-2-2910-3838  
Fax : 886-2-2917-3838