

## TWO PHASE SYNCHRONOUS PWM CONTROLLER WITH INTEGRATED FET DRIVER AND DIFFERENTIAL CURRENT SENSE

PRELIMINARY DATA SHEET

**Pb Free Product**

### DESCRIPTION

The NX2420 is a two-phase PWM controller with integrated FET driver designed for low voltage high current application. The two phase synchronous buck converter offers ripple cancelation for both input and output. The NX2420 uses differential remote sensing using either current sense resistor or inductor DCR sensing to achieve accurate current matching between the two channels. Differential sensing eliminates the error caused by PCB board trace resistance that is otherwise present when using a single ended voltage sensing. In addition the NX2420 offers high drive current capability especially for keeping the synchronous MOSFET off during SW node transition, accurate programmable droop allowing to reduce number of output capacitors, accurate enable circuit provides programmable start up point for Bus voltage, PGOOD output, programmable switching frequency and hiccup current limiting circuitry.

### FEATURES

- Differential inductor DCR sensing eliminates the problem with layout parasitic
- External programmable voltage droop
- Low Impedance On-board Drivers
- Hiccup current limit and IOOUT indication
- Power Good for power sequencing
- Enbus allows programming the BUS voltage start up threshold
- Programmable frequency
- Prebias start up
- OVP protection without negative spike at output
- Selectable between internal and external reference
- Pb-free and RoHS compliant

### APPLICATIONS

- Graphic card High Current Vcore Supply
- High Current on board DC to DC converter applications

### TYPICAL APPLICATION

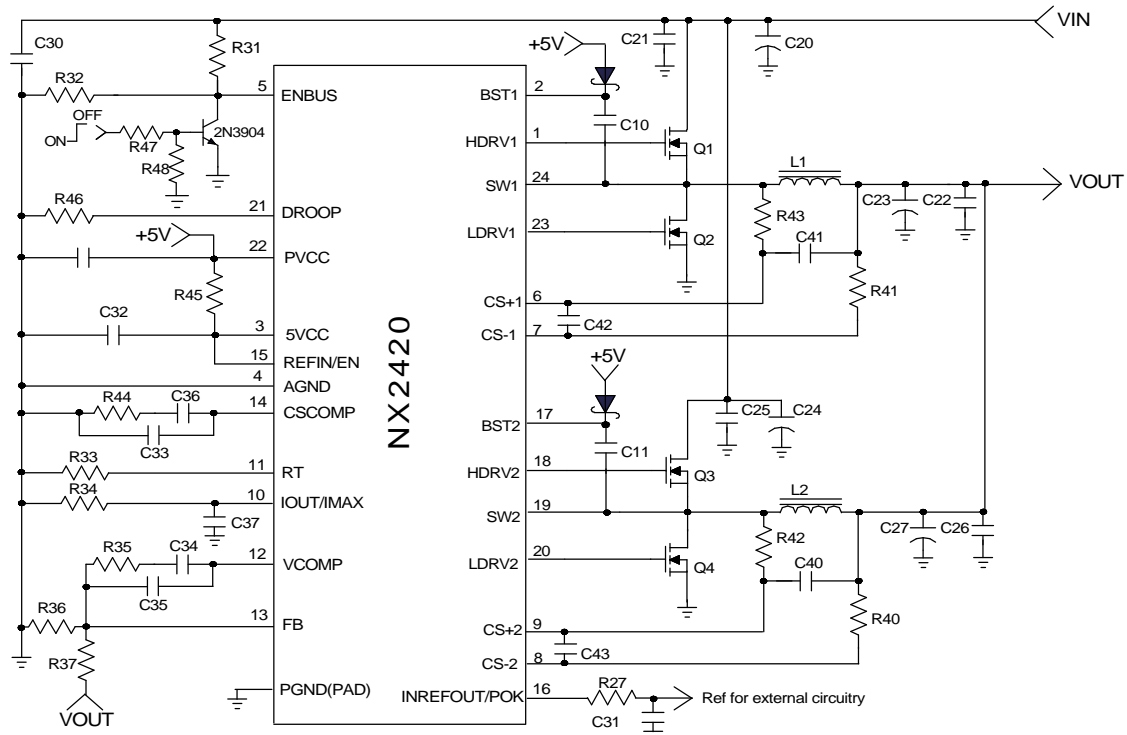

Figure1 - Typical application of NX2420

### ORDERING INFORMATION

Device	Temperature	Package	Frequency	Pb-Free
NX2420CMTR	0 to 70°C	MLPQ 4x4 - 24L	50kHz to 1MHz	Yes

## ABSOLUTE MAXIMUM RATINGS

Vcc to PGND & BST to SW voltage .....	-0.3V to 6.5V
BST to PGND Voltage .....	-0.3V to 35V
SW to PGND .....	-2V to 35V
All other pins .....	-0.3V to 6.5V
Storage Temperature Range .....	-65°C To 150°C
Operating Junction Temperature Range .....	-40°C To 125°C
Lead temperature(Soldering 5s) .....	260°C

CAUTION: Stresses above those listed in "ABSOLUTE MAXIMUM RATINGS", may cause permanent damage to the device. This is a stress only rating and operation of the device at these or any other conditions above those indicated in the operational sections of this specification is not implied.

## PACKAGE INFORMATION

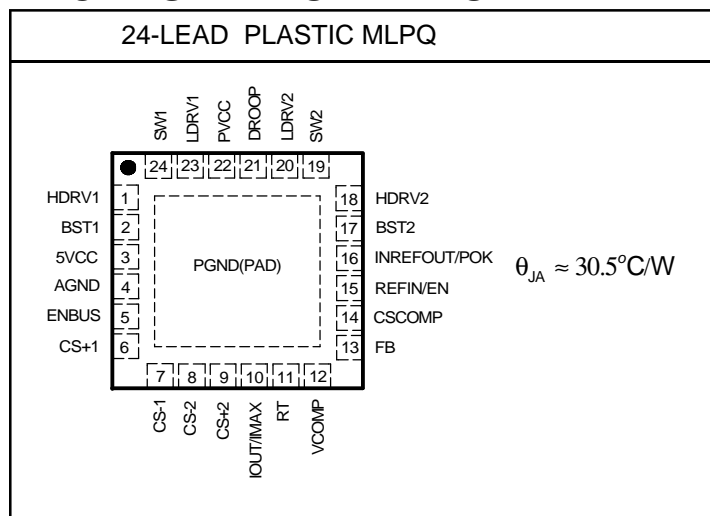

## ELECTRICAL SPECIFICATIONS

Unless otherwise specified, these specifications apply over  $5V_{CC} = 5V$ ,  $PV_{CC} = 5V$ ,  $V_{BST} - V_{SW} = 5V$ ,  $ENBUS = HIGH$ , and  $T_A = 0$  to  $70^{\circ}\text{C}$ . Typical values refer to  $T_A = 25^{\circ}\text{C}$ . Low duty cycle pulse testing is used which keeps junction and case temperatures equal to the ambient temperature.

PARAMETER	SYM	TEST CONDITION	MIN	TYP	MAX	UNITS
<b>Supply Voltage(Vcc)</b>						
$5V_{CC}, PV_{CC}$ Voltage Range	$V_{CC}$		4.5	5	5.5	V
$5V_{CC}$ Supply Current (static)	$I_{CC}$ (Static)	ENBUS=GND	-	6.7		mA
$PV_{CC}$ Supply Current (Dynamic)	$I_{CC}$ (Dynamic)	REFIN=ENBUS=5VCC, Freq=200Khz per phase $C_{LOAD}=2200PF$		4.4		mA
$V_{BST}$ Voltage Range	$V_{BST}$ to $V_{SW}$		4.5	5	5.5	V
$V_{BST}$ Supply Current ((Dynamic))	$V_{BST}$ (Dynamic)	REFIN=ENBUS=5VCC, Freq=200Khz per phase $C_{LOAD}=2200PF$		4.5		mA

PARAMETER	SYM	TEST CONDITION	MIN	TYP	MAX	UNITS
<b>Under Voltage, Vcc &amp; ENBUS</b>						
V <sub>CC</sub> -Threshold	V <sub>CC_UVLO</sub>	V <sub>CC</sub> Rising		4.1		V
V <sub>CC</sub> -Hysteresis	V <sub>CC_Hyst</sub>			0.4		V
ENBUS Threshold		V <sub>BUS</sub> Rising		0.82		V
ENBUS Hysteresis				80		mV
<b>Reference Voltage</b>						
Ref Voltage	V <sub>REF</sub>	4.5V<V <sub>CC</sub> <5.5V		0.592		V
Ref Voltage line regulation				0.2		%
<b>Oscillator (Rt)</b>						
Frequency for each phase	F <sub>s</sub>	Rt=100kohm		400		KHz
Ramp-Amplitude Voltage	V <sub>RAMP</sub>			1.02		V
Ramp Peak				2.2		V
Ramp Valley				1.18		V
Max Duty Cycle		200Khz/Phase		97		%
Min Duty Cycle					0	%
<b>Transconductance Amplifiers(CSCOMP)</b>						
Open Loop Gain			50	65		dB
Transconductance				1600		umoh
<b>Voltage Mode Error</b>						
Open Loop Gain			50			dB
Input Offset Voltage	V <sub>io_v</sub>			0		mV
Output Current Source			5			mA
Output Current Sink			5			mA
Output HI Voltage			V <sub>CC</sub> -1.5			V
Output LOW Voltage					0.5	V
<b>SS (Internal )</b>						
Soft Start time	T <sub>SS</sub>	400Khz/Phase		2.5		mS
<b>POK/INFEROUT</b>						
Threshold		V <sub>FB</sub> Rising		73		%V <sub>P</sub>
Hysteresis				5		%
POK Voltage		I <sub>OUT</sub> =5mA(sourcing)	1.191	1.215	1.24	V
<b>High Side Driver (C<sub>L</sub>=4700pF)</b>						
Output Impedance , Sourcing Current	R <sub>source</sub> (Hdrv)	I=200mA		1		ohm
Output Impedance , Sinking Current	R <sub>sink</sub> (Hdrv)	I=200mA		0.7		ohm
Rise Time	T <sub>Hdrv</sub> (Rise)	10% to 90%		19		ns
Fall Time	T <sub>Hdrv</sub> (Fall)	90% to 10%		18.5		ns
Deadband Time	T <sub>dead</sub> (L to H)	Ldrv going Low to Hdrv going High, 10%-10%		40		ns
<b>Low Side Driver (C<sub>L</sub>=10000pF)</b>						
Output Impedance, Sourcing Current	R <sub>source</sub> (Ldrv)	I=200mA		1		ohm
Output Impedance, Sinking Current	R <sub>sink</sub> (Ldrv)	I=200mA		0.5		ohm

PARAMETER	SYM	TEST CONDITION	MIN	TYP	MAX	UNITS
Rise Time	TLdrv(Rise)	10% to 90%		34		ns
Fall Time	TLdrv(Fall)	90% to 10%		18		ns
Deadband Time	Tdead(H to L)	SW going Low to Ldrv going High, 10% to 10%		10		ns
Propagation Delay	Tdealy(H)	IN going High to Ldrv going Low		14		ns
<b>Current Sense Amplifier(CS+, CS-)</b>						
Input Offset Voltage			-2		2	mV
Voltage Gain			29.7	30	30.3	V/V
<b>Droop Voltage Current Source(Droop)</b>						
Droop Voltage Current Source		V(IOUT)=0.6V, feedback resistor=10k, Rdroop=60kohm		10		uA
<b>OVP Threshold</b>						
OVP Threshold		percent of Vp		130		%
<b>FB UVLO Threshold</b>						
FB UVLO Threshold		percent of Vp		70		%
<b>REFIN VOLTAGE</b>						
REFIN Voltage Range			0.4		2.5	V
Disable Voltage Threshold			0.3	0.35	0.4	V
Threshold Enable Internal Reference				75		%VCC

## PIN DESCRIPTIONS

PIN #	SYMBOL	PIN DESCRIPTION
1	HDRV1	High side gate driver for Channel 1.
2	BST1	Bootstrap supply for Channel 1.
3	5VCC	IC's supply voltage. This pin biases the internal logic circuits. A minimum 1uF ceramic capacitor is recommended to connect this pin to ground plane.
4	AGND	Controller analog ground pin.
5	ENBUS	This pin is used to program the under voltage lockout of the bus supply. A resistor divider from the bus voltage to this pin programs the under voltage lockout. When the voltage of this pin is greater than 0.8V, the bus voltage is assumed in operation. The pin has a 10% hysteresis.
6	CS+1	Positive input of the channel 1 differential current sense amplifiers. It is connected directly to the RC junction of the respective phase's output inductor.
7	CS-1	Negative input of the channel 1 differential current sense amplifiers. It is connected directly to the negative side of the respective phase's output inductor.
8	CS-2	Negative input of the channel 2 differential current sense amplifiers. It is connected directly to the negative side of the respective phase's output inductor.
9	CS+2	Positive input of the channel 2 differential current sense amplifiers. It is connected directly to the RC junction of the respective phase's output inductor.
10	IOUT/IMAX	This pin indicates average output current level and sets OCP threshold using a resistor from this pin to ground. A no more than 1nF ceramic capacitor is recommended to connect this pin to ground plane to filter the noise on this pin.
11	RT	This pin programs the internal oscillator frequency using a resistor from this pin to ground. The frequency of each phase is 1/2 of this frequency.
12	VCOMP	This is the output pin of the error amplifier.
13	FB	This pin is the error amplifier inverting input. It is connected to the output voltage via a voltage divider.
14	CSCOMP	The output of the transconductance op amp for current balance circuit. An external RC is connected from this pin to GND to stabilize the current loop.
15	REFIN/EN	External reference input. If pull-up to >75%VCC, internal reference is used. If driven by an external voltage ranged from 0.4V to 2.5V, external reference is used with slew rate following SS rate. If REFIN is below 0.4V, device is disabled.
16	INREFOUT/ POK	This pin has dual functions. When FB pin is below 75% of internal 0.6V reference, this pin is held low. When FB reaches above this threshold, this pin is tied to an internal 1.25V reference, allowing it to be used as a reference for any external op amp circuitry as well as an indicator of power OK. This pin can not be connected directly to an output capacitor. An RC network is needed which also provides a slow ramp up of the reference for the external op amp.

PIN #	SYMBOL	PIN DESCRIPTION
17	BST2	Bootstrap supply for Channel 2.
18	HDRV2	High side gate driver for Channel 2.
19	SW2	Switch node for Channel2.
20	LDRV2	Low side gate driver for Channel 2.
21	DROOP	A resistor from this pin to ground programs an internal current source that is fed into the FB pin. This current source is proportional to the output current of the regulator. The product of this current times the external resistor $R_{FB}$ provides a droop voltage.
22	PVCC	This pin provide the supply voltage for the lower MOSFET drivers. A high frequency ceramic 1uF X5R must be placed close to this pin and tied to PGND to provide peak current needed for low side MOSFETs.
23	LDRV1	Low side gate driver for Channel 1.
24	SW1	Switch node for Channel 1.
PAD	PGND	This is the ground connection for the power stage of the controller.

## BLOCK DIAGRAM

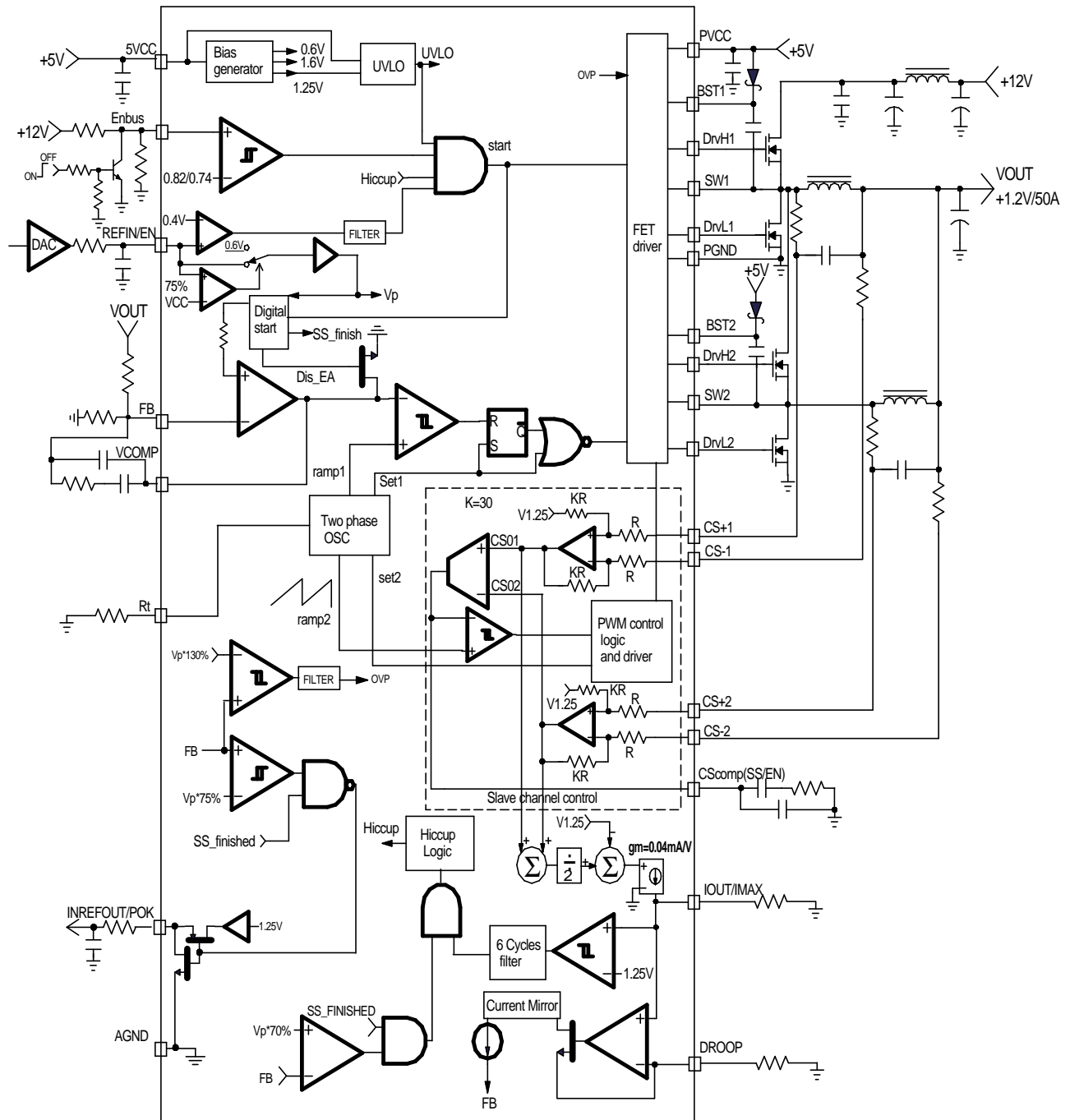

Figure 2 - block diagram of NX2420

## Demoboard design and waveforms

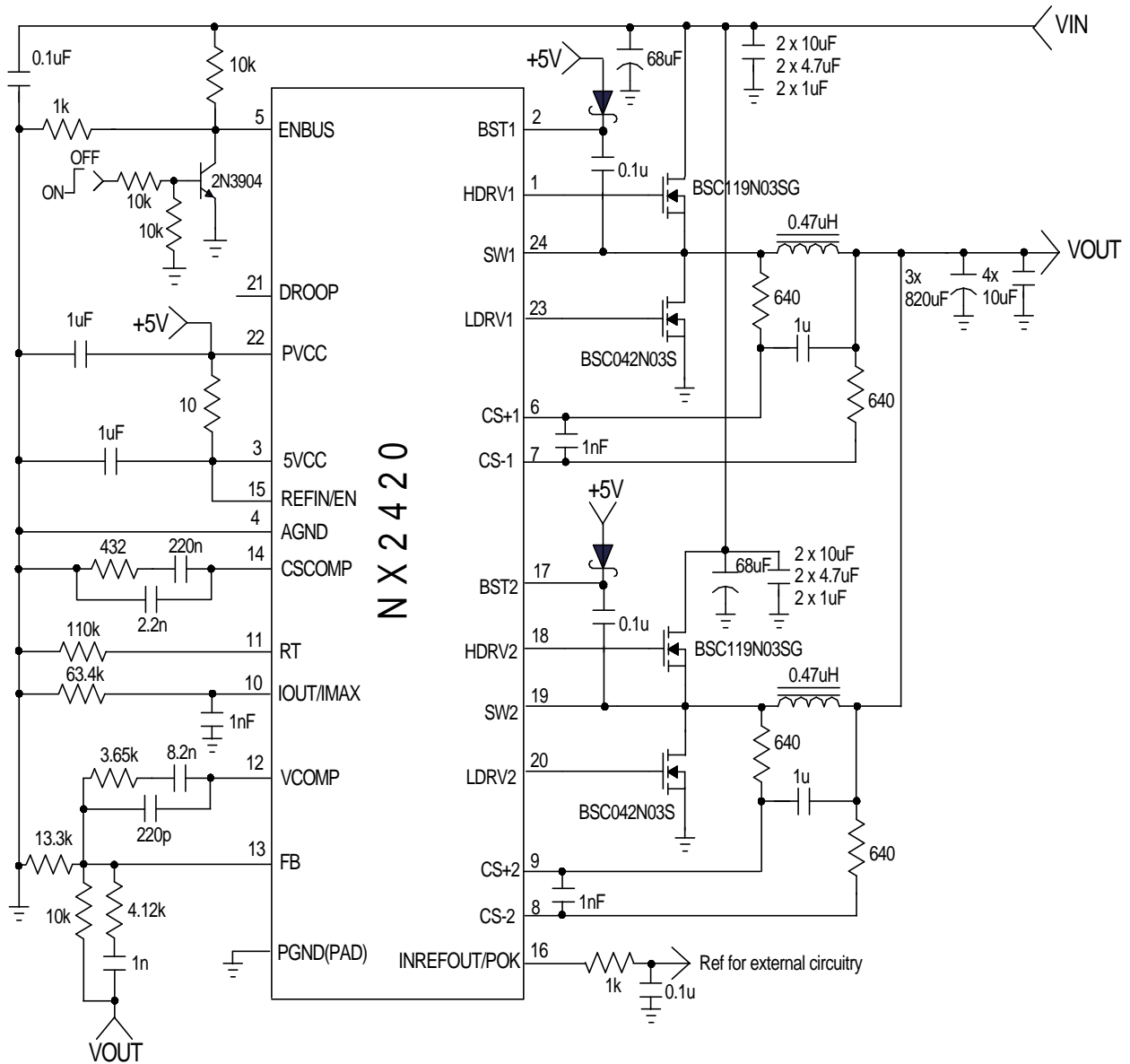

Figure 3 - demoboard schematic of NX2420



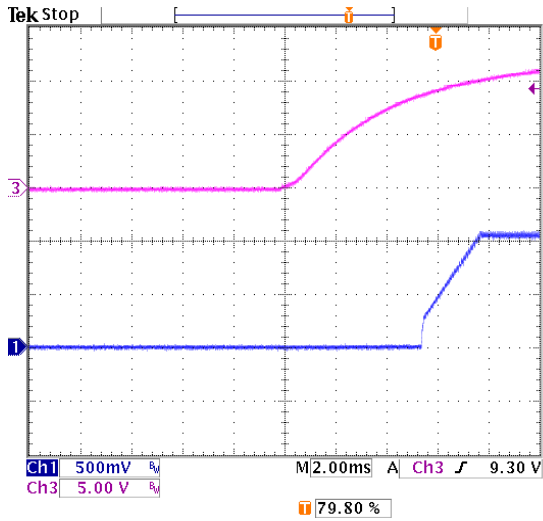

Figure 3 - Start up

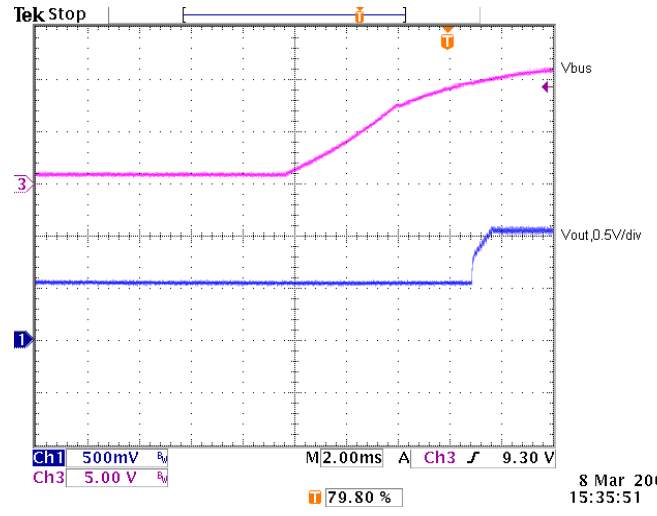

Figure 4 - Prebias start up

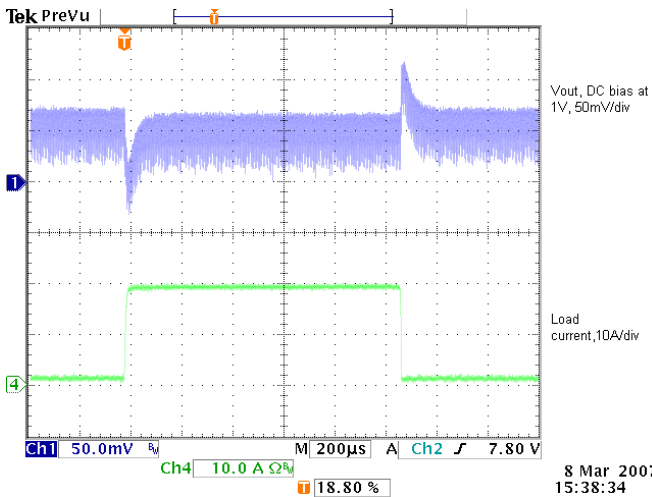

Figure 5 - Transient response

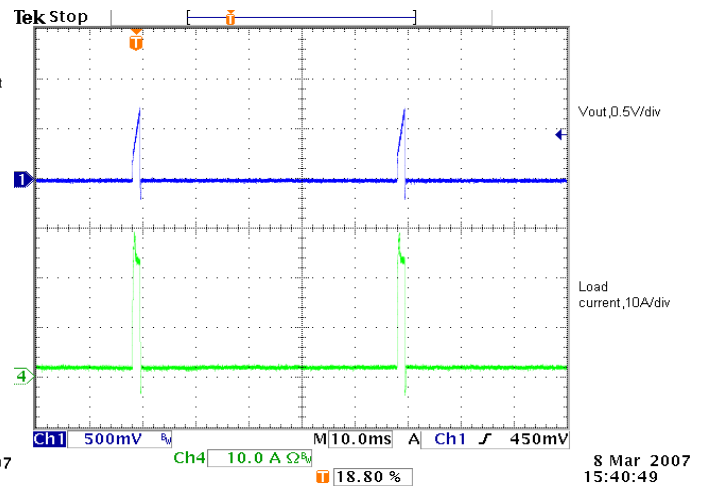

Figure 6 - Over current protection

NX2420 efficiency(%) vs Iout

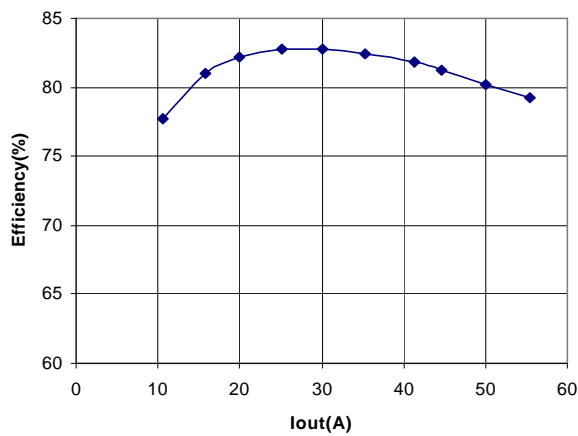

Figure 7: Efficiency

## APPLICATION INFORMATION

### Symbol Used In Application Information:

$V_{IN}$	- Input voltage
$V_{OUT}$	- Output voltage
$I_{OUT}$	- Output current
$\Delta V_{RIPPLE}$	- Output voltage ripple
$F_s$	- Operation frequency for each channel
$\Delta I_{RIPPLE}$	- Inductor current ripple

### Design Example

The following is typical application for NX2420.

$V_{IN} = 12V$
$V_{OUT} = 1.2V$
$I_{OUT} = 50A$
$I_{OUT\_max} = 60A$
$\Delta V_{RIPPLE} \leq 12mV$
$\Delta V_{DROOP} \leq 120mV$ @30A step
$F_s = 400kHz$
Phase number $N = 2$

### Output Inductor Selection

The selection of inductor value is based on inductor ripple current, power rating, working frequency and efficiency. Larger inductor value normally means smaller ripple current. However if the inductance is chosen too large, it brings slow response and lower efficiency. Usually the ripple current ranges from 20% to 40% of the output current. This is a design freedom which can be decided by design engineer according to various application requirements. The inductor value can be calculated by using the following equations:

$$L_{OUT} = \frac{V_{IN} - V_{OUT}}{\Delta I_{RIPPLE}} \times \frac{V_{OUT}}{V_{IN}} \times \frac{1}{F_s} \quad \dots(1)$$

$$\Delta I_{RIPPLE} = k \times \frac{I_{OUTPUT}}{N}$$

where k is between 0.2 to 0.4.

Select  $k = 0.2$ , then

$$L_{OUT} = \frac{12V - 1.2V}{0.2 \times \frac{50A}{2}} \times \frac{1.2V}{12V} \times \frac{1}{400kHz}$$

$$L_{OUT} = 0.54\mu H$$

Choose inductor from Vishay IHLP\_5050FD-01 with  $L = 0.68\mu H$  DCR = 1.4m $\Omega$ .

Current Ripple is recalculated as

$$\Delta I_{RIPPLE} = \frac{V_{IN} - V_{OUT}}{L_{OUT}} \times \frac{V_{OUT}}{V_{IN}} \times \frac{1}{F_s}$$

$$= \frac{12V - 1.2V}{0.68\mu H} \times \frac{1.2V}{12V} \times \frac{1}{400kHz} = 3.97A \quad \dots(2)$$

### Output Capacitor Selection

Output capacitor value is basically decided by the output voltage ripple, capacitor RMS current rating and load transient.

#### Based on Voltage Ripple

For electrolytic, POSCAP bulk capacitor, the ESR (equivalent series resistance) and inductor current typically determines the output voltage ripple.

$$ESR_{desire} = \frac{\Delta V_{RIPPLE}}{\Delta I_{RIPPLE}} = \frac{12mV}{3.97A} = 3.022m\Omega \quad \dots(3)$$

If low ESR is required, for most applications, multiple capacitors in parallel are better than a big capacitor. For example, for 12mV output ripple, SANYO OSCON capacitors 2R5SEPC1000MX(1000uF 7m $\Omega$ ) are chosen.

$$N = \frac{ESR_E \times \Delta I_{RIPPLE}}{\Delta V_{RIPPLE}} \quad \dots(4)$$

Number of Capacitor is calculated as

$$N = \frac{7m\Omega \times 3.97A}{12mV}$$

$$N = 2.3$$

For ceramic capacitor, the current ripple is determined by the number of capacitor instead of ESR

$$C_{OUT} = \frac{\Delta I_{RIPPLE}}{8 \times F_s \times \Delta V_{RIPPLE}} \quad \dots(5)$$

Typically, the calculated capacitance is so small that the output voltage droop during the transient can not meet the spec although ripple is small.

## Based On Transient Requirement

Typically, the output voltage droop during transient is specified as:

$$\Delta V_{\text{DROOP}} < \Delta V_{\text{TRAN}} \text{ @ step load } \Delta I_{\text{STEP}}$$

During the transient, the voltage droop during the transient is composed of two sections. One Section is dependent on the ESR of capacitor, the other section is a function of the inductor, output capacitance as well as input, output voltage. For example, overshoot caused by  $\Delta I_{\text{STEP}}$  transient load which is from high load to low load, can be estimated as the following equation, if assuming the bandwidth of system is high enough.

$$\Delta V_{\text{overshoot}} = \text{ESR} \times \Delta I_{\text{step}} + \frac{V_{\text{OUT}}}{2 \times L \times C_{\text{OUT}}} \times \tau^2 \quad \dots(6)$$

where  $\tau$  is the a function of capacitor, etc.

$$\tau = \begin{cases} 0 & \text{if } L_{\text{EFF}} \leq L_{\text{crit}} \\ \frac{L_{\text{EFF}} \times \Delta I_{\text{step}}}{V_{\text{OUT}}} - \text{ESR} \times C_{\text{OUT}} & \text{if } L_{\text{EFF}} \geq L_{\text{crit}} \end{cases} \quad \dots(7)$$

where

$$L_{\text{EFF}} = \frac{L_{\text{OUT}}}{N} = \frac{0.68\mu\text{H}}{2} = 0.34\mu\text{H}$$

$$L_{\text{crit}} = \frac{\text{ESR} \times C_{\text{OUT}} \times V_{\text{OUT}}}{\Delta I_{\text{step}}} = \frac{\text{ESR}_E \times C_E \times V_{\text{OUT}}}{\Delta I_{\text{step}}} \quad \dots(8)$$

where  $\text{ESR}_E$  and  $C_E$  represents ESR and capacitance of each capacitor if multiple capacitors are used in parallel.

The above equation shows that if the selected output inductor is smaller than the critical inductance, the voltage droop or overshoot is only dependent on the ESR of output capacitor. For low frequency capacitor such as electrolytic capacitor, the product of ESR and capacitance is high and  $L \leq L_{\text{crit}}$  is true. In that case, the transient spec is dependent on the ESR of capacitor.

In most cases, the output capacitors are multiple capacitors in parallel. The number of capacitors can be calculated by the following

$$N = \frac{\text{ESR}_E \times \Delta I_{\text{step}}}{\Delta V_{\text{tran}}} + \frac{V_{\text{OUT}}}{2 \times L \times C_E \times \Delta V_{\text{tran}}} \times \tau^2 \quad \dots(9)$$

where

$$\tau = \begin{cases} 0 & \text{if } L_{\text{EFF}} \leq L_{\text{crit}} \\ \frac{L_{\text{EFF}} \times \Delta I_{\text{step}}}{V_{\text{OUT}}} - \text{ESR}_E \times C_E & \text{if } L_{\text{EFF}} \geq L_{\text{crit}} \end{cases} \quad \dots(10)$$

For example, assume voltage droop during transient is 120mV for 30A load step.

If the OS-CON capacitors (1000uF, 7mΩ) is used, the critical inductance is given as

$$L_{\text{crit}} = \frac{\text{ESR}_E \times C_E \times V_{\text{OUT}}}{\Delta I_{\text{step}}} = \frac{7\text{m}\Omega \times 1000\mu\text{F} \times 1.2\text{V}}{30\text{A}} = 0.28\mu\text{H}$$

The effective inductor value is 0.34uH which is bigger than critical inductance. In that case, the output voltage transient not only dependent on the ESR, but also capacitance.

number of capacitors is

$$\tau = \frac{L_{\text{EFF}} \times \Delta I_{\text{step}}}{V_{\text{OUT}}} - \text{ESR}_E \times C_E$$

$$= \frac{0.34\mu\text{H} \times 30\text{A}}{1.2\text{V}} - 7\text{m}\Omega \times 1000\mu\text{F} = 1.5\mu\text{s}$$

$$N = \frac{\text{ESR}_E \times \Delta I_{\text{step}}}{\Delta V_{\text{tran}}} + \frac{V_{\text{OUT}}}{2 \times L_{\text{EFF}} \times C_E \times \Delta V_{\text{tran}}} \times \tau^2$$

$$= \frac{7\text{m}\Omega \times 30\text{A}}{120\text{mV}} + \frac{1.2\text{V}}{2 \times 0.34\mu\text{H} \times 1000\mu\text{F} \times 120\text{mV}} \times (1.5\mu\text{s})^2$$

$$= 1.78$$

The number of capacitors has to satisfied both ripple and transient requirement. Overall, we can choose  $N=2$ .

It should be considered that the proposed equation is based on ideal case, in reality, the droop or overshoot is typically more than the calculation. The equation gives a good start. For more margin, more capacitors have to be chosen after the test. Typically, for high frequency capacitor such as high quality POSCAP especially ceramic capacitor, 20% to 100% (for ceramic) more capacitors have to be chosen since the ESR of capacitors is so low that the PCB parasitic can affect the results tremendously. More capacitors have to be selected to compensate these parasitic parameters.

## Control Loop Compensator Design

NX2420 can control and drive two channel synchronous bucks with 180° phase shift between each other. One of two channels is called master, the other is called slave. They are connected together by sharing the same output capacitors. Voltage loop is designed to regulate output voltage. In order to achieve the current balance in these two synchronous buck converters, current loop compensation network is employed to make sure the currents in slave is following the master.

## Voltage Loop Compensator Design

Due to the double pole generated by LC filter of the power stage, the power system has 180° phase shift, and therefore, is unstable by itself. In order to achieve accurate output voltage and fast transient response, compensator is employed to provide highest possible bandwidth and enough phase margin. Ideally, the Bode plot of the closed loop system has crossover frequency between 1/10 and 1/5 of the switching frequency, phase margin greater than 50° and the gain crossing 0dB with -20dB/decade. Power stage output capacitors usually decide the compensator type. If electrolytic capacitors are chosen as output capacitors, type II compensator can be used to compensate the system, because the zero caused by output capacitor ESR is lower than crossover frequency. Otherwise type III compensator should be chosen.

### A. Type II compensator design

If the electrolytic capacitors are chosen as power stage output capacitors, usually the Type II compensator can be used to compensate the system.

Type II compensator can be realized by simple RC circuit without feedback as shown in figure 8. R3 and C1 introduce a zero to cancel the double pole effect. C2 introduces a pole to suppress the switching noise. The following equations show the compensator pole zero location and constant gain.

$$\text{Gain} = \frac{R_3}{R_2} \quad \dots (11)$$

$$F_z = \frac{1}{2 \times \pi \times R_3 \times C_1} \quad \dots (12)$$

$$F_p \approx \frac{1}{2 \times \pi \times R_3 \times C_2} \quad \dots (13)$$

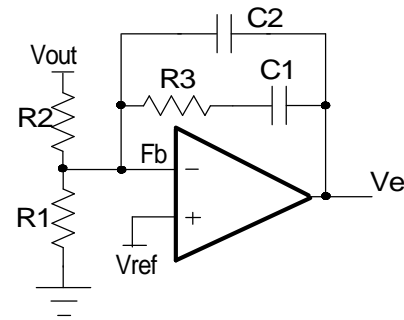

Figure 8 - Type II compensator

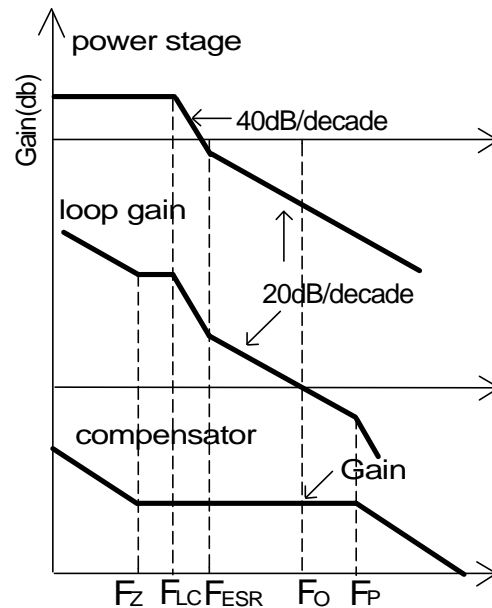

Figure 9 - Bode plot of Type II compensator

For this type of compensator,  $F_o$  has to satisfy  $F_{LC} < F_{ESR} \ll F_o$  and  $F_o \leq 1/10 \sim 1/5 F_s$ .

Here a type II compensator is designed for the case which has six electrolytic capacitors (1800uF, 13mΩ) and

two 1.5uH inductors.

1. Calculate the location of LC double pole  $F_{LC}$  and ESR zero  $F_{ESR}$ :

$$F_{LC} = \frac{1}{2 \times \pi \times \sqrt{L_{EFF} \times C_{OUT}}}$$

$$= \frac{1}{2 \times \pi \times \sqrt{0.75 \mu H \times 10800 \mu F}}$$

$$= 1.768 \text{ kHz}$$

$$F_{ESR} = \frac{1}{2 \times \pi \times ESR \times C_{OUT}}$$

$$= \frac{1}{2 \times \pi \times 13 \text{ m}\Omega \times 1800 \mu F}$$

$$= 6.801 \text{ kHz}$$

2. Set  $R_2$  equal to 10k $\Omega$  and calculate  $R_1$ .

$$R_1 = \frac{R_2 \times V_{REF}}{V_{OUT} - V_{REF}} = \frac{10 \text{ k}\Omega \times 0.6 \text{ V}}{1.2 \text{ V} - 0.6 \text{ V}} = 10 \text{ k}\Omega$$

3. Set crossover frequency  $F_o = 15 \text{ kHz}$ .

4. Calculate  $R_3$  value by the following equation.

$$R_3 = \frac{V_{OSC}}{V_{in}} \times \frac{2 \times \pi \times F_o \times L_{EFF} \times R_2}{ESR}$$

$$= \frac{1 \text{ V}}{12 \text{ V}} \times \frac{2 \times \pi \times 15 \text{ kHz} \times 0.75 \mu H}{2.16 \text{ m}\Omega} \times 10 \text{ k}\Omega$$

$$= 27.3 \text{ k}\Omega$$

Choose  $R_3 = 27.4 \text{ k}\Omega$ .

5. Calculate  $C_1$  by setting compensator zero  $F_z$  at 75% of the LC double pole.

$$C_1 = \frac{1}{2 \times \pi \times R_3 \times F_z}$$

$$= \frac{1}{2 \times \pi \times 27.4 \text{ k}\Omega \times 0.75 \times 1.768 \text{ kHz}}$$

$$= 4.4 \text{ nF}$$

Choose  $C_1 = 4.7 \text{ nF}$ .

6. Calculate  $C_2$  by setting compensator pole  $F_p$  at half the switching frequency.

$$C_2 = \frac{1}{\pi \times R_3 \times F_s}$$

$$= \frac{1}{\pi \times 27.4 \text{ k}\Omega \times 400 \text{ kHz}}$$

$$= 30 \text{ pF}$$

Choose  $C_2 = 33 \text{ pF}$ .

## B. Type III compensator design

For low ESR output capacitors, typically such as Sanyo OSCON and POSCAP, the frequency of ESR zero caused by output capacitors is higher than the crossover frequency. In this case, it is necessary to compensate the system with type III compensator.

In design example, six electrolytic capacitors are used as output capacitors. The system is compensated with type III compensator. The following figures and equations show how to realize the this type III compensator with electrolytic capacitors.

$$F_{Z1} = \frac{1}{2 \times \pi \times R_4 \times C_2} \quad \dots(14)$$

$$F_{Z2} = \frac{1}{2 \times \pi \times (R_2 + R_3) \times C_3} \quad \dots(15)$$

$$F_{P1} = \frac{1}{2 \times \pi \times R_3 \times C_3} \quad \dots(16)$$

$$F_{P2} = \frac{1}{2 \times \pi \times R_4 \times \frac{C_1 \times C_2}{C_1 + C_2}} \quad \dots(17)$$

where  $F_{Z1}, F_{Z2}, F_{P1}$  and  $F_{P2}$  are poles and zeros in the compensator.

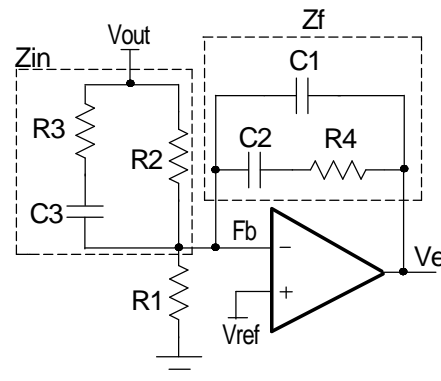

Figure 10 - Type III compensator

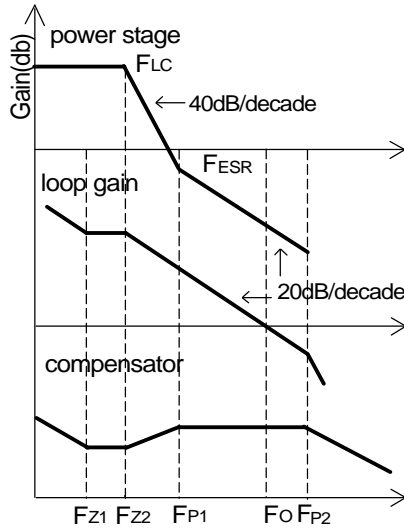

Figure 11 - Bode plot of Type III compensator

The transfer function of type III compensator is given by:

$$\frac{V_e}{V_{OUT}} = \frac{1}{sR_2 \times (C_2 + C_1)} \times \frac{(1 + sR_4 \times C_2) \times [1 + s(R_2 + R_3) \times C_3]}{(1 + sR_4 \times \frac{C_2 \times C_1}{C_2 + C_1}) \times (1 + sR_3 \times C_3)}$$

Use the same power stage requirement as demo board. The crossover frequency has to be selected as  $F_{LC} < F_{ESR} < F_o$ , and usually  $F_o \leq 1/10 \sim 1/5 F_s$ .

1. Calculate the location of LC double pole  $F_{LC}$  and ESR zero  $F_{ESR}$ .

$$F_{LC} = \frac{1}{2 \times \pi \times \sqrt{L_{EFF} \times C_{OUT}}} = \frac{1}{2 \times \pi \times \sqrt{0.34 \mu H \times 2000 \mu F}} = 6.1 \text{ kHz}$$

$$F_{ESR} = \frac{1}{2 \times \pi \times ESR \times C_{OUT}} = \frac{1}{2 \times \pi \times 3.5 \text{ m}\Omega \times 2000 \mu F} = 22.7 \text{ kHz}$$

2. Set  $R_2$  equal to  $10 \text{ k}\Omega$ .

$$R_1 = \frac{R_2 \times V_{REF}}{V_{OUT} - V_{REF}} = \frac{10 \text{ k}\Omega \times 0.6 \text{ V}}{1.2 \text{ V} - 0.6 \text{ V}} = 10 \text{ k}\Omega$$

Choose  $R_1 = 10 \text{ k}\Omega$ .

3. Calculate  $C_3$  by setting  $F_{Z2} = F_{LC}$  and  $F_{p1} = F_{ESR}$ .

$$C_3 = \frac{1}{2 \times \pi \times R_2} \times \left( \frac{1}{F_{Z2}} - \frac{1}{F_{p1}} \right) = \frac{1}{2 \times \pi \times 10 \text{ k}\Omega} \times \left( \frac{1}{6.1 \text{ kHz}} - \frac{1}{22.7 \text{ kHz}} \right) = 1.9 \text{ nF}$$

Choose  $C_3 = 1.8 \text{ nF}$ .

5. Calculate  $R_3$  by equation (13).

$$R_3 = \frac{1}{2 \times \pi \times F_{p1} \times C_3} = \frac{1}{2 \times \pi \times 22.7 \text{ kHz} \times 1.8 \text{ nF}} = 3.89 \text{ k}\Omega$$

Choose  $R_3 = 3.92 \text{ k}\Omega$ .

6. Calculate  $R_4$  by choosing  $F_o = 40 \text{ kHz}$ .

$$R_4 = \frac{V_{OSC}}{V_{in}} \times \frac{2 \times \pi \times F_o \times L_{EFF}}{ESR} \times \frac{R_2 \times R_3}{R_2 + R_3} = \frac{1 \text{ V}}{12 \text{ V}} \times \frac{2 \times \pi \times 40 \text{ kHz} \times 0.34 \mu H}{3.5 \text{ m}\Omega} \times \frac{10 \text{ k}\Omega \times 3.92 \text{ k}\Omega}{10 \text{ k}\Omega + 3.92 \text{ k}\Omega} = 5.73 \text{ k}\Omega$$

Choose  $R_4 = 5.62 \text{ k}\Omega$ .

7. Calculate  $C_2$  with zero  $F_{z1}$  at 75% of the LC double pole by equation (11).

$$C_2 = \frac{1}{2 \times \pi \times F_{z1} \times R_4} = \frac{1}{2 \times \pi \times 0.75 \times 6.1 \text{ kHz} \times 5.62 \text{ k}\Omega} = 6.2 \text{ nF}$$

Choose  $C_2 = 6.8 \text{ nF}$ .

8. Calculate  $C_1$  by equation (14) with pole  $F_{p2}$  at half the switching frequency.

$$C_1 = \frac{1}{2 \times \pi \times R_4 \times F_{p2}} = \frac{1}{2 \times \pi \times 5.62 \text{ k}\Omega \times 200 \text{ kHz}} = 141 \text{ pF}$$

Choose  $C_1 = 150 \text{ pF}$ .

## Current Loop Compensator Design

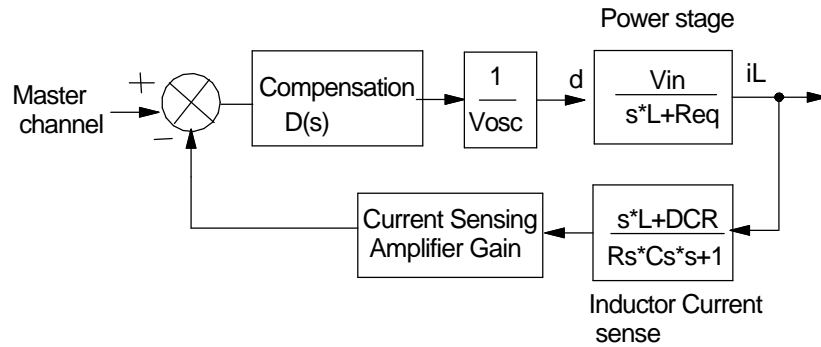

Figure 12 - Current loop control diagram

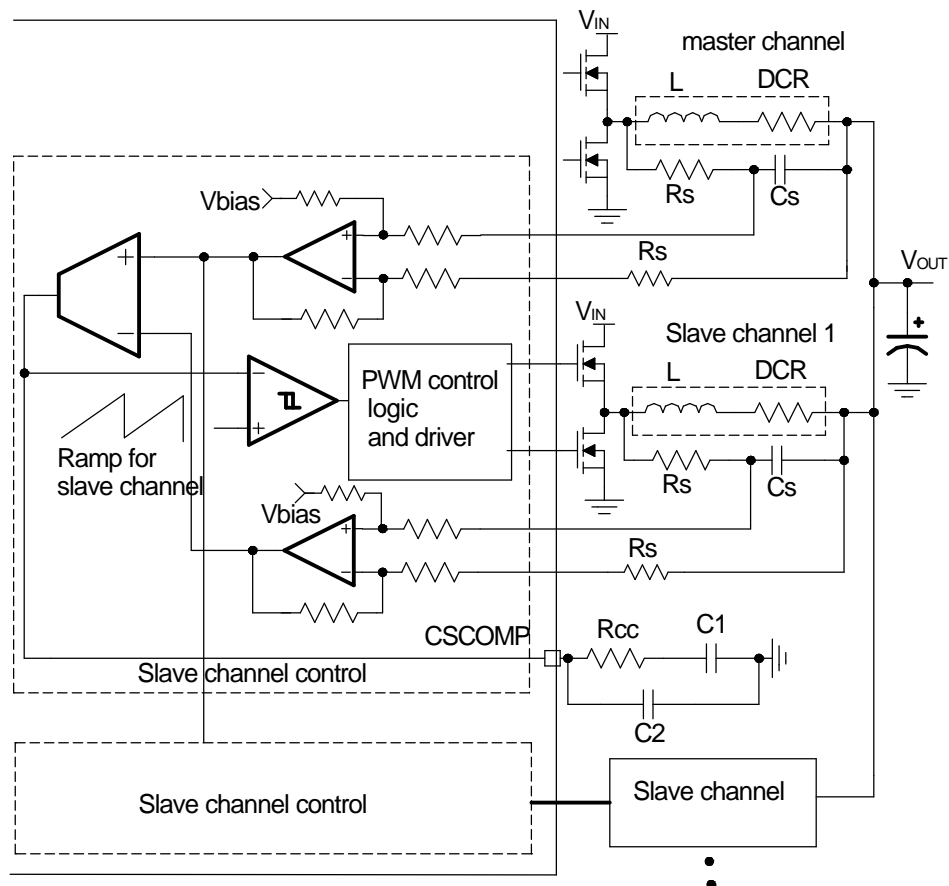

Figure 13 - Function diagram of current loop

## Inductor Current Sensing

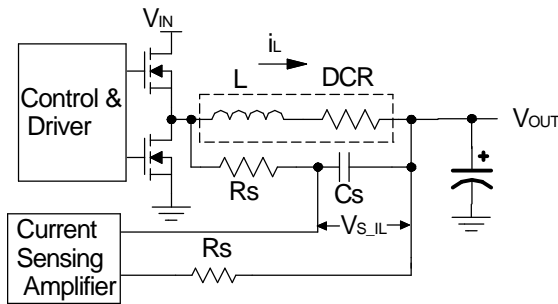

Figure 14 - Inductor current sensing using RC network.

The inductor current can be sensed through a RC network as shown above. The advantage of the RC network is the lossless comparing with a resistor in series with output inductor.

The selection of the resistor sensing network is chosen by the following equation:

$$R_s \times C_s = \frac{L}{DCR} \quad \dots(18)$$

If the above equation is satisfied, the voltage across the sensing capacitor Cs will be equal to the inductor current times DCR of inductor for all frequency domain.

$$V_{s\_IL} = DCR \times i_L$$

If the sensing capacitor is chosen

$$C_s = 1\mu F$$

Cs must be X7R or COG ceramic capacitor.

The sensing resistor is calculated as

$$R_s = \frac{L}{DCR \times C_s}$$

For example, for 0.68uH inductor with 1.4mΩ DCR, we have

$$R_s = \frac{0.68\mu H}{1.4m\Omega \times 1\mu F} = 486\Omega$$

In most of cases, the selection of sensing resistor based on the above equation will be sufficient. However, for some inductor such as toroid coiled inductor with micrometal, even the product of sensing resistor and capacitor is perfectly match with L/DCR, the voltage across the capacitor still has overshoot due to the nonlinearity of inductor. This will affect the droop accuracy during the transient if droop function is required. The illustration is shown in the following figure.

racy during the transient if droop function is required. The illustration is shown in the following figure.

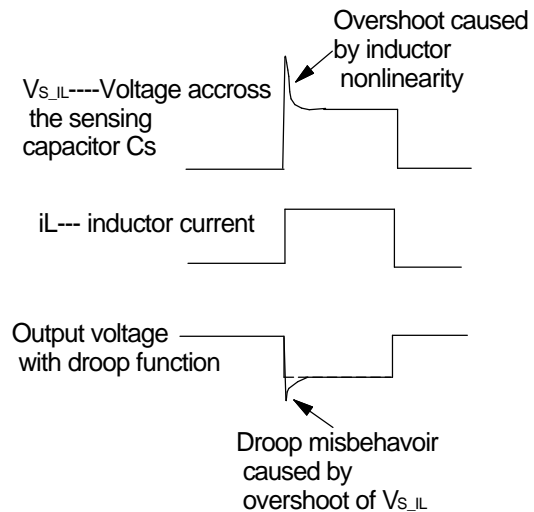

Figure 15 - Droop accuracy affected by the nonlinearity of inductor.

In this case, the sensing resistor has to be chosen

$$R_s \geq \frac{L}{DCR \times C_s}$$

to compensate the overshoot. This selection only affects the small signal mode of current loop. For DC accuracy, there is no effect since the DC voltage across the sensing capacitor will equal to the DCR times inductor current at DC load no matter what Rs is. In this example, Rs=620Ω.

Rs value is preferred to be less than 400Ω in NX2420's application, therefore we need to reiterate the calculation, choose Cs 2.2uF instead. Rs value is finally chosen as 301Ω .

Power dissipation of Rs resistor is calculated as followed:

$$\begin{aligned} P_D(R_s) &= \frac{(V_{IN} - V_{OUT})^2}{R_s} \times D + \frac{V_{OUT}^2}{R_s} \times (1 - D) \\ &= \frac{(12V - 1.2V)^2}{301\Omega} \times 0.1 + \frac{(1.2V)^2}{301\Omega} \times (1 - 0.1) \\ &= 0.04W \end{aligned}$$

The power rating of Rs should be over 0.04W.



## Current Loop Compensation

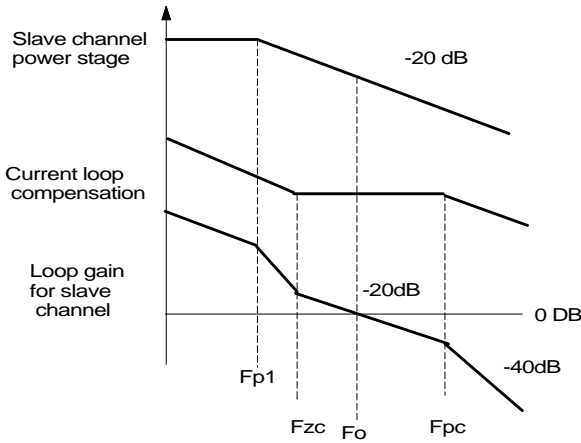

Figure 16 - Bode plot of current loop

The diagram and bode plot for current loop of NX2420 is shown in above figures. The current signal through inductor sensing is amplified by current sensing differential amplifier. The amplified slave current signal is compared with the amplified inductor current from master channel (channel 1 for NX2420) through a transconductance amplifier, the difference between channel current will change the output of transconductance amplifier, which will compare with a internal ramp signal and changes the duty cycle of slave channel buck converter. If the inductor are perfectly matched and the PWM controller has no offset, the DC current in slave channel will equal to the DC current of master channel (channel 1) due to the gain of current loop.

From the bode plot, the power stage has one pole located at

$$F_{P1} = \frac{R_{eq}}{2 \times \pi \times L}$$

where  $R_{eq}$  is the equivalent resistor and it is given by

$$R_{eq} \approx DCR + R_{dson\_con} \times \frac{V_{OUT}}{V_{IN}} + R_{dson\_syn} \times \left(1 - \frac{V_{OUT}}{V_{IN}}\right)$$

$R_{dson\_con}$  is the  $R_{dson}$  of control FET and  $R_{dson\_syn}$  is the  $R_{dson}$  of synchronous FET. For this example,

$$R_{eq} = 7.4m\Omega$$

The pole is located as

$$F_{P1} = \frac{R_{eq}}{2 \times \pi \times L} = \frac{7.4m\Omega}{2 \times \pi \times 0.68\mu H} = 1.7kHz$$

The current compensation transfer function is given as

$$D(s) = \frac{g_m}{s \times (C_1 + C_2)} \times \frac{1 + s \times R_{cc} \times C_1}{1 + s \times \frac{R_{cc} \times C_1 \times C_2}{C_1 + C_2}}$$

It has one zero and one pole. The ideal is to choose resistor  $R_{cc}$  to achieve desired loop gain such as 50kHz.  $R_{cc}$  can be calculated as

$$R_{cc} = \frac{2 \times \pi \times F_o \times L \times V_{osc}}{g_m \times V_{IN} \times K_C \times DCR} \quad \dots(19)$$

where

$$K_C \approx \frac{60 \cdot k\Omega}{2k\Omega + R_s} = 22.9$$

60k $\Omega$  and 2k $\Omega$  is the internal resistance for the current sensing amplifier.

For fast response, we can set the current loop cross-over frequency one and half times of voltage loop cross-over frequency. Since the voltage loop cross-over frequency is typically selected as 1/10 of switching frequency, we choose  $F_o = 50kHz$ .

$$R_{cc} = \frac{2 \times \pi \times 50kHz \times 0.68\mu H \times 1V}{1.6mA/V \times 12V \times 22.9 \times 1.4m\Omega} = 442\Omega$$

Select

$$R_{cc} = 430\Omega$$

The selection of capacitor  $C_1$  is such that the zero of compensation will cancel the pole of power stage, therefore,

$$C_1 = \frac{L}{R_{eq} \times R_{cc}} = \frac{0.68\mu H}{7.4m\Omega \times 430\Omega} = 214nF$$

Typically, the capacitor  $C_1$  is so big that the current loop may start slowly during the start up. Therefore, smaller capacitor can be selected. However, the selected capacitor can not reduce too much to cause phase droop.

Select  $C_1 = 220nF$ .

The capacitor  $C_2$  is an option and it is used to filter out the switching noise.  $C_2$  can be calculated as

$$C_2 = \frac{1}{\pi \times R_{cc} \times F_s} = \frac{1}{\pi \times 430\Omega \times 400kHz} = 1.85nF$$

Select  $C_2=2.2nF$ .

## Frequency Selection

The frequency can be set by external  $R_t$  resistor. The relationship between frequency per phase and  $R_t$  pin around 400kHz is shown as follows.

$$R_T \approx \frac{40000000}{F_s} \quad \dots(20)$$

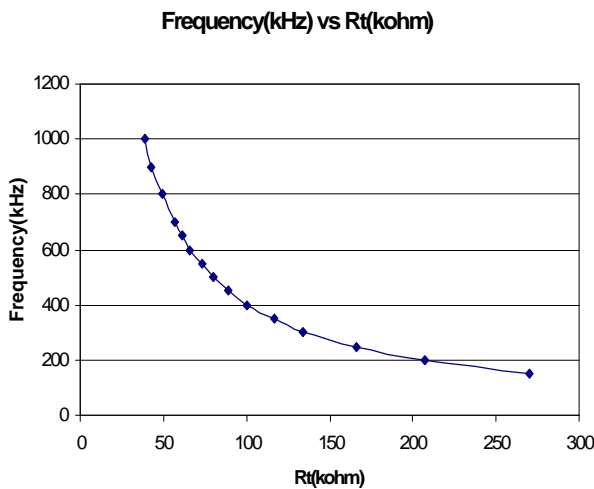

Figure 17 - Frequency vs  $R_t$  chart

## Output Voltage Droop Operation

The effective output impedance of the controller must be adjusted to maximize the output voltage fluctuation range. A program resistor attached to the Droop pin  $R_{DROOP}$  will program this value. The function works by an internal current source connected to the FB pin. This current flows output of the FB pin and through the  $R_{in}$  resistance from the FB pin to the output.

This current source is a function of the sensed output current. As the output current increases, the droop current will increase and causes the output voltage to droop proportionately. The droop current is programmed by a resistor attached to the Droop pin. The value of the resistor is chosen as follows.

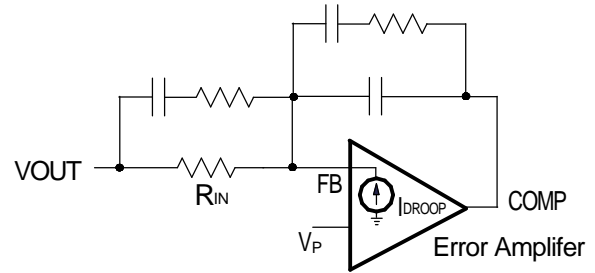

Figure 18 - Output voltage droop function

$$\Delta V_{OUT} = I_{DROOP} \times R_{IN} = \Delta I_{LOAD} \times R_{LL} \quad \dots(21)$$

Where  $R_{LL}$  is desired load impedance. For example, if we want  $V_{out}$  droops 60mV @ 20A,

$$R_{LL} = \frac{60mV}{20A} = 3m\Omega$$

$$I_{DROOP} = \frac{V(I_{OUT})}{R_{DROOP}} = \frac{0.6 \times \frac{60k\Omega}{2k\Omega + R_s} \times \frac{DCR}{2} \times I_{LOAD}}{R_{DROOP}} \quad \dots(22)$$

Combine equation 22 and 23,

$$R_{DROOP} = \frac{0.6}{2} \times \frac{60k\Omega}{2k\Omega + R_s} \times \frac{DCR I_{LOAD} R_{IN}}{\Delta V_{OUT}} \quad \dots(23)$$

Where DCR is the sense resistor or the DCR of the output inductor.  $R_s$  is the current sensing matching resistor when using DCR sensing method.  $I_{LOAD}$  is the load current.  $R_{IN}$  is the input DC resistor of the master phase compensator which connect FB pin and VOUT. For example, to have the  $\Delta V_{OUT}=60mV$  when the load current is 20A, DCR is 1.4m $\Omega$ ,  $R_{IN}$  is 10k $\Omega$ ,  $R_s$  is 620 $\Omega$ .

$$R_{DROOP} = \frac{0.6}{2} \times \frac{60k\Omega}{2k\Omega + 0.62k\Omega} \times \frac{1.4m\Omega \times 20A \times 10k\Omega}{60mV} = 32k\Omega$$

Choose  $R_{DROOP} = 32k\Omega$ .

## Over Voltage Protection

Over voltage protection is achieved by sensing the output voltage through resistor divider. The sensed voltage on FB pin is compared with  $130\% \times V_{REF}$  to generate the OVP signal.

## Over Current/Short Circuit Protection

The converter will go into hiccup mode if the output current reaches a programmed limit  $I_{ocp}$  determined by the resistor value  $R_{ocp}$  at pin IOUT/IMAX.

$$R_{ocp} = \frac{1.25V}{0.04mA/V} \times \frac{2k\Omega + R_s}{60k\Omega} \times \frac{2}{DCR} \times \frac{1}{I_{ocp}} \quad \dots(24)$$

Where  $I_{ocp}$  is the desired over current protection level,  $R_s$  is the current sensing matching resistor when using DCR sensing method.

## Input Filter Selection

The selection criteria of input capacitor are voltage rating and the RMS current rating. For conservative consideration, the capacitor voltage rating should be 1.5 times higher than the maximum input voltage. The RMS current rating of the input capacitor for multi-phase converter can be estimated from the above Figure 19.

First, determine the duty cycle of the converter ( $V_o/V_{in}$ ). The ratio of input RMS current over output current can be obtained. Then the total input RMS current can be calculated. From this figure, it is obvious that a multi-phase converter can have a much smaller input RMS current, which results in a lower amount of input capacitors that are required.

For example,  $V_{in}=12V$ ,  $V_{out}=1.2V$ . The duty cycle is  $D=V_{out}/V_{in}=1.2/12=10\%$ . From the figure, for two phase, the normalized RMS current is  $0.2 \times I_{out}=0.2 \times 50A=10A$ .

A combination of ceramic and electrolytic(SANYO WG or WF series) or OSCON type capacitors can achieve both ripple current capability together with having enough capacitance such that input voltage will not sag too much. In this application, one OSCON SVPC180M(180uF, 16V, 2.8A) and three 10uF X5R ceramic capacitors are selected.

A 1uH input inductor is recommended to slow down the input current transient. Suppose power stage efficiency is 0.8, then input current can be estimated by

$$I_{INPUT} = \frac{I_{OUT} \times V_{OUT}}{\eta \times V_{IN}} = \frac{60A \times 1.2V}{0.8 \times 12V} = 7.5A$$

In this application, Coilcraft DO3316P\_102HC with RMS rating 10A is chosen.

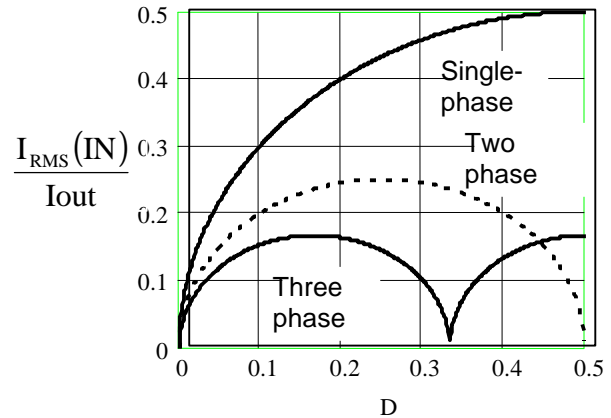

Figure 19 - Normalized input RMS current vs. duty cycle.

## Power MOSFETs Selection

The NX2420 requires two N-Channel power MOSFETs for each channels. The selection of MOSFETs is based on maximum drain source voltage, gate source voltage, maximum current rating, MOSFET on resistance and power dissipation. The main consideration is the power loss contribution of MOSFETs to the overall converter efficiency. In this design example, eight NTD60N02 are used. They have the following parameters:  $V_{DS}=25V$ ,  $I_D=62A$ ,  $R_{DS(ON)}=12m\Omega$ ,  $Q_{GATE}=9nC$ .

There are three factors causing the MOSFET power loss: conduction loss, switching loss and gate driver loss.

Gate driver loss is the loss generated by discharging the gate capacitor and is dissipated in driver circuits. It is proportional to frequency and is defined as:

$$P_{gate} = (Q_{HGATE} \times V_{HGS} + Q_{LGATE} \times V_{LGS}) \times F_s \quad \dots(25)$$

where  $Q_{HGATE}$  is the high side MOSFETs gate charge,  $Q_{LGATE}$  is the low side MOSFETs gate charge,  $V_{HGS}$  is the high side gate source voltage, and  $V_{LGS}$  is the low side gate source voltage. This power dissipation should not exceed maximum power dissipation of the driver device.

Conduction loss is simply defined as:

$$\begin{aligned} P_{HCON} &= I_{OUT}^2 \times D \times R_{DS(ON)} \times K \\ P_{LCON} &= I_{OUT}^2 \times (1-D) \times R_{DS(ON)} \times K \\ P_{TOTAL} &= P_{HCON} + P_{LCON} \end{aligned} \quad \dots(26)$$

Where the  $R_{DS(ON)}$  will increase as MOSFET junction temperature increases,  $K$  is  $R_{DS(ON)}$  temperature dependency and should be selected for the worst case. Conduction loss should not exceed package rating or overall system thermal budget.

Switching loss is mainly caused by crossover conduction at the switching transition. The total switching loss can be approximated.

$$P_{SW} = \frac{1}{2} \times V_{IN} \times I_{OUT} \times T_{SW} \times F_s \quad \dots(27)$$

$T_{SW}$  is the sum of  $T_R$  and  $T_F$  which can be found in mosfet datasheet,  $I_{OUT}$  is output current, and  $F_s$  is switching frequency. Switching loss  $P_{SW}$  is frequency dependent.

## Soft Start and Enable Signal Operation

The NX2420 will start operation only after 5VCC and PVCC have reached their threshold voltages and ENBUS have been enabled. The ENBUS pin can be programmed to turn on the converter at any input voltage. The ENBUS pin has a threshold voltage of 0.8V.

Once the converter starts, there is a soft start sequence of 1024 steps between 0 and  $V_p$ . The ramp rate is determined by the switching frequency.

$$\frac{dV_o}{dt} = \frac{V_o}{1024 \times T_s} \quad \dots(28)$$

The softstart time is calculated as followed:

$$T_{startup} = \frac{1024}{F_s} \quad \dots(29)$$

## Layout Considerations

The layout is very important when designing high frequency switching converters. Layout will affect noise pickup and can cause a good design to perform with less than expected results.

There are two sets of components considered in the layout which are power components and small signal components. Power components usually consist of input capacitors, high-side MOSFET, low-side MOSFET, inductor and output capacitors. A noisy environment is generated by the power components due to the switching power. Small signal components are connected to sensitive pins or nodes. A multilayer layout which in-

cludes power plane, ground plane and signal plane is recommended.

Layout guidelines:

1. First put all the power components in the top layer connected by wide, copper filled areas. The input capacitor, inductor, output capacitor and the MOSFETs should be close to each other as possible. This helps to reduce the EMI radiated by the power loop due to the high switching currents through them.

2. Low ESR capacitor which can handle input RMS ripple current and a high frequency decoupling ceramic cap which usually is 1uF need to be practically touching the drain pin of the upper MOSFET, a plane connection is a must.

3. The output capacitors should be placed as close as to the load as possible and plane connection is required.

4. Drain of the low-side MOSFET and source of the high-side MOSFET need to be connected thru a plane as close as possible. A snubber needs to be placed as close to this junction as possible.

5. Source of the lower MOSFET needs to be connected to the GND plane with multiple vias. One is not enough. This is very important. The same applies to the output capacitors and input capacitors.

6. Hdrv and Ldrv pins should be as close to MOSFET gate as possible. The gate traces should be wide and short. A place for gate drv resistors is needed to fine tune noise if needed.

7. Vcc capacitor, BST capacitor or any other bypassing capacitor needs to be placed first around the IC and as close as possible. The capacitor on comp to GND or comp back to FB needs to be placed as close to the pin as well as resistor divider.

8. The output sense line which is sensing output back to the resistor divider should not go through high frequency signals.

9. All GNDs need to go directly thru via to GND plane.

10. The feedback part of the system should be kept away from the inductor and other noise sources, and be placed close to the IC.

11. In multilayer PCB, separate power ground and

analog ground. These two grounds must be connected together on the PC board layout at a single point. The goal is to localize the high current path to a separate loop that does not interfere with the more sensitive analog control function.

12. Inductor current sense line should be connected directly to the inductor solder pad.

## Typical Application with external reference

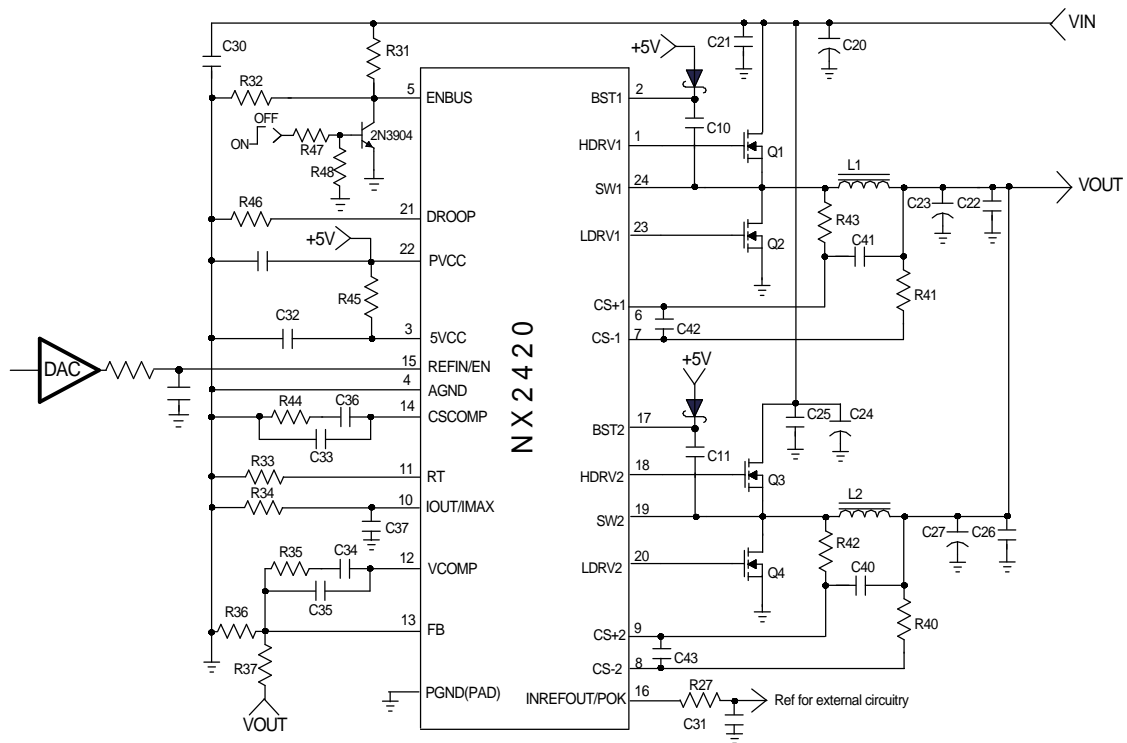
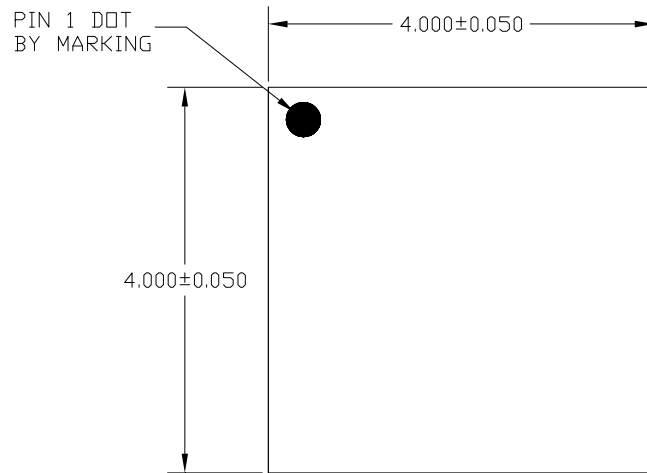
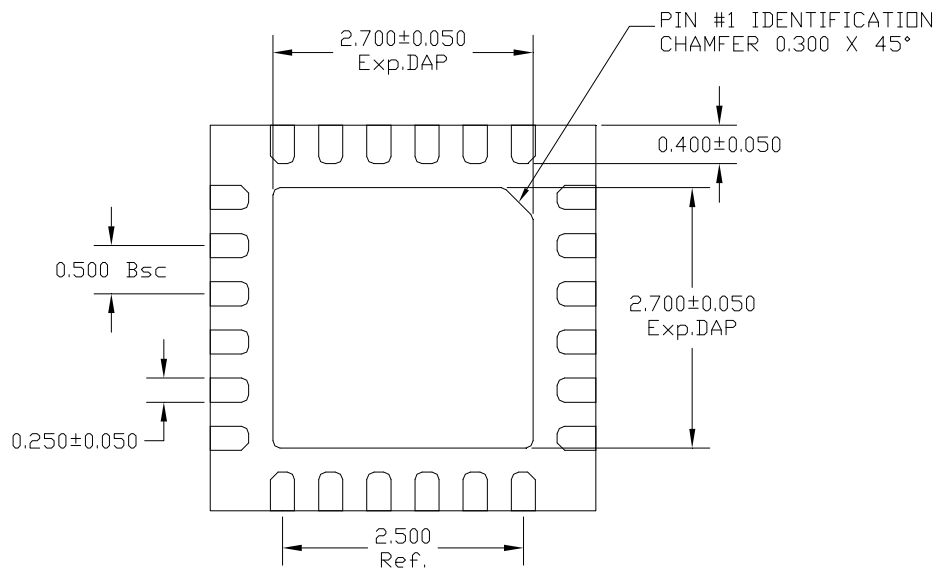

Figure 20 - Typical application of NX2420 with external reference

## MLPQ 24 PIN 4 x 4 PACKAGE OUTLINE DIMENSIONS



TOP VIEW



BOTTOM VIEW

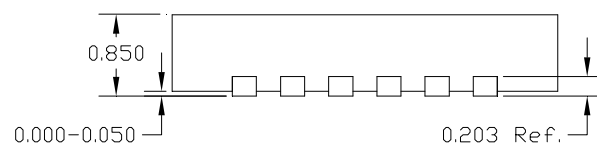

SIDE VIEW

NOTE: ALL DIMENSIONS ARE DISPLAYED IN MILLIMETERS.

## MLPQ 24 PIN 4 x 4 TAPE AND REEL INFORMATION

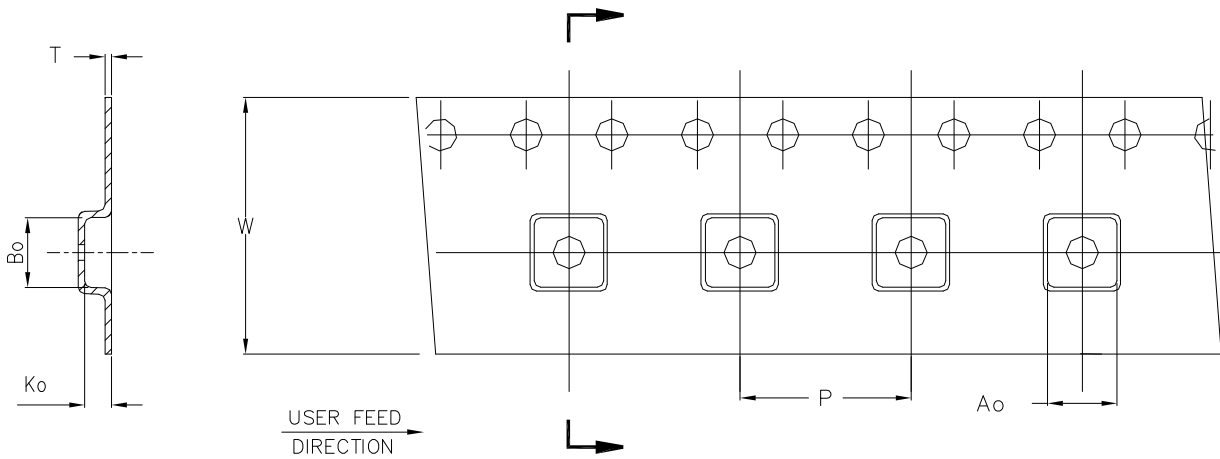

Dimension	MLPQ 04X04
Ao	4.35 +/− 0.1
B0	4.35 +/− 0.1
K0	1.1 +/− 0.1
P	8 +/− 0.1
W	12 +/− 0.3
T	0.3 +/− 0.05
R7/Quantity	1000
R13/Quantity	3000

**NOTE:**

1. R7 = 7 INCH LOCK REEL, R13 = 13 INCH LOCK REEL.
2. ALL DIMENSIONS ARE DISPLAYED IN MILLIMETERS.