



Edited by Bill Travis

## 5V power supply teams low-dropout regulator, charge pump

Jim Christensen, Maxim Integrated Products, Sunnyvale, CA

**A**UXILIARY POWER of 3.3V is replacing the 5V auxiliary power that “silver boxes” supply in most computer systems, but some circuits still require a 5V supply. Such systems impose the messy task of creating a central 5V auxiliary supply from the 3.3V auxiliary supply and then routing 5V power throughout the motherboard. An alternative exists, however, for systems in which only a few ICs need 5V: Employ inexpensive charge pumps as low-power 3.3V-to-5V converters and place them directly at the 5V loads. Regulated charge pumps do this job, but they are uncommon, and they often command a premium price. You can build a regulated charge pump by combining an unregulated charge pump with a low-dropout regulator that reduces the voltage to 5V. Unfortunately, that method requires a low-dropout regulator rated

**TABLE 1—POWER-SUPPLY PARAMETERS WITH ALL 1- $\mu$ F CAPACITORS**

V <sub>OUT</sub> (V)	I <sub>OUT</sub> (mA)	P <sub>OUT</sub> (mW)	I <sub>IN</sub> at V <sub>IN</sub> =3.3V (mA)	P <sub>IN</sub> (mW)	Efficiency (%)	V <sub>OUT</sub> low-dropout regulator (V)	V <sub> RIPPLE</sub> (mV p-p)
5.06	10	50.6	20.9	68.8	73.5	2.71	358
5.01	20	100.2	41.1	135.6	73.9	2.86	312
4.9	30	147	62.2	205.3	71.6	3.02	420

**TABLE 2—POWER-SUPPLY PARAMETERS WITH ALL 3- $\mu$ F CAPACITORS**

V <sub>OUT</sub> (V)	I <sub>OUT</sub> (mA)	P <sub>OUT</sub> (mW)	I <sub>IN</sub> at V <sub>IN</sub> =3.3V (mA)	P <sub>IN</sub> (mW)	Efficiency (%)	V <sub>OUT</sub> low-dropout regulator (V)	V <sub> RIPPLE</sub> (mV p-p)
4.99	10	49.9	20.37	68.8	74.2	2.63	154
4.99	20	99.8	40.4	133.3	74.9	2.76	104
4.98	30	149.4	60.6	200	74.7	2.89	154
4.93	40	197.2	80.5	265.7	74.2	3.02	192
4.9	45	220.5	90.5	298.7	73.8	3.09	214

for at least 7V, because an unregulated charge pump can deliver 7V when its 3.3V input goes to the upper limit of tolerance. That fact eliminates the possibility of using the latest low-cost, low-dropout regulators, whose small geometry limits their maximum input to 6.5V.

You can reverse the order by placing the low-dropout regulator in front of the charge pump, thereby reducing the 3.3V to 2.5V before doubling it. That approach allows the use of a low-cost, low-voltage, low-dropout regulator, but the charge-pump output impedance then becomes an issue. A low-cost charge pump, such as the MAX1683, operating with 1- $\mu$ F capacitors exhibits a typical output impedance of 35 $\Omega$ , making it unusable at currents above a few milliamps. The circuit of **Figure 1** shows a better way to cascade the charge pump with a

voltage regulator. The low-dropout regulator, IC<sub>1</sub>, reduces the 3.3V input to a lower value, and the unregulated charge pump, IC<sub>2</sub>, doubles that value to 5V. To cancel the voltage drop that charge-pump output impedance causes, the circuit feeds the 5V output back to the low-dropout regulator, which alters its output to maintain output regulation. The available headroom of at least 1V allows output currents to approximately 30 mA or even higher with larger capacitors. Although it requires two ICs instead of a single regulated charge pump, this approach can be cheaper because high-vol-

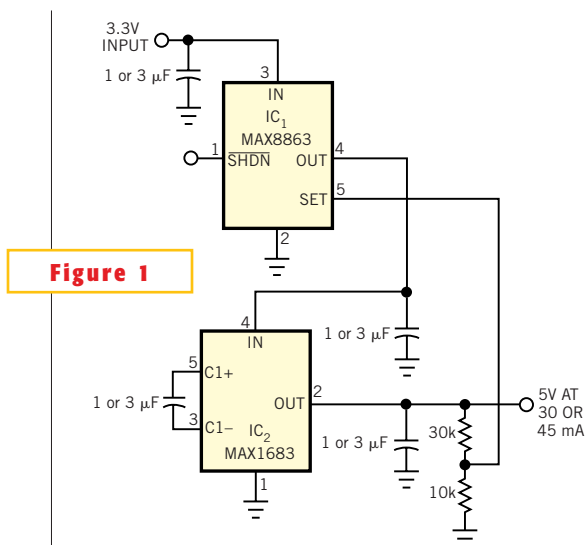

**Figure 1**

**This 5V supply, which you obtain by reducing the 3.3V input with a low-dropout regulator and doubling that output with a charge pump, minimizes the charge-pump output impedance by feeding 5V back to the regulator.**

5V power supply teams low-dropout regulator, charge pump ..... **59**

Four-quadrant power supply provides any-polarity voltage and current ..... **60**

Simple circuit controls stepper motors ..... **64**

Simple dc/dc converter increases available power in dual-voltage system ..... **66**

**Publish your Design Idea in EDN. See the What's Up section at www.edn.com.**

ume applications use unregulated charge pumps and low-current, low-voltage, low-dropout regulators. Furthermore, because the low-dropout regulator and charge pump are available in SOT-23 packages, the overall footprint of the circuit in **Figure 1** is comparable to that of

a regulated-charge-pump circuit.

**Table 1** demonstrates the circuit's ability to maintain output-voltage regulation and deliver currents as high as 30 mA; the input, output, and flying capacitors are all 1  $\mu\text{F}$ . Similarly, **Table 2** shows the regulation for output currents to 45 mA; all

capacitors are 3  $\mu\text{F}$ . As you can see, load current does not affect efficiency, which is approximately equal to the output voltage divided by twice the input voltage. Capacitor values affect the ripple voltage and available output current but have little effect on efficiency. □

## Four-quadrant power supply provides any-polarity voltage and current

Jon Munson, Linear Technology, Milpitas, CA

**A** CONVENTIONAL power supply operates only in the first quadrant; positive-voltage output and current are sourced to a load or, with a deliberately miswired output, statically in the third quadrant as a “minus” supply. The conventional supply cannot, however, operate in either the second quadrant as an adjustable load for a minus supply, for example, or the fourth quadrant as a discharge-testing a battery with a specific constant current, for example. It also cannot transition seamlessly between the various modes as a function of load condition or control input. The circuit in **Figure 1** achieves full four-quadrant capability with an output topology similar to that of an ordinary audio power amplifier by using a “complementary” pass-transistor configuration. The complementary section may be the basic op-amp output in lower current designs or use external power MOSFETs in cases involving higher power. Controlling the output in the various modes is a simple matter when you use

the LT1970 power op amp to manage the operation, thanks to its built-in, closed-loop, current-limiting features.

The four-quadrant supply provides at

ed  $\pm 17\text{V}$  bulk power source (not shown). You configure the user-control potentiometers,  $V_{\text{SET}}$  and  $I_{\text{LIMIT}}$ , to provide buffered command signals:  $V_{\text{CONTROL}}$  and

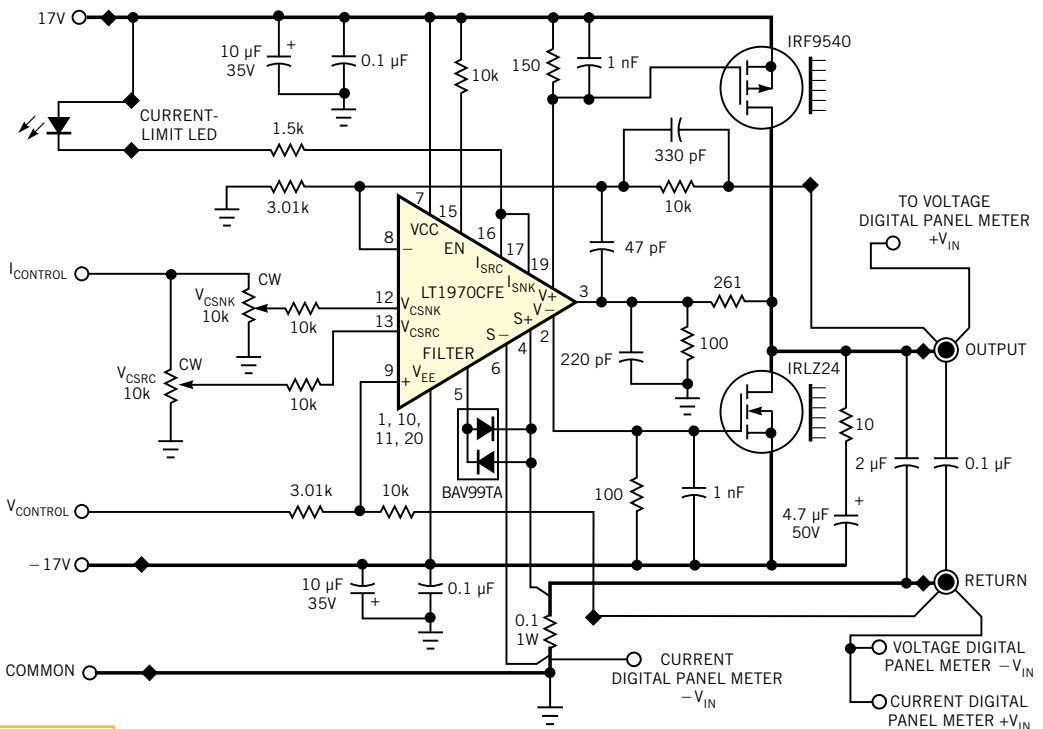

**Figure 1**

You can obtain four-quadrant power-supply operation by using a power op amp in the output section.

least  $\pm 16\text{V}$  adjustability with as much as  $\pm 2\text{A}$  output capability. **Figure 1** shows the basic LT1970-based regulator section. **Figure 2** shows the user-control analog section, using an LT1790-5 reference and an LT1882 quad-precision op amp. The entire circuit operates from a preregulated-

$V_{\text{CONTROL}}$ , respectively (**Figure 2**). You can adjust  $V_{\text{CONTROL}}$  from  $-5$  to  $+5\text{V}$ , and the LT1970 regulator circuit amplifies it to form the nominal  $\pm 16.5\text{V}$  output range. You can adjust  $I_{\text{CONTROL}}$  from 0 to 5V; 5V represents the maximum user current-limit command. The  $V_{\text{CSNK}}$  and  $V_{\text{CSRC}}$

trimmers attenuate the  $I_{\text{CONTROL}}$  signal to set the precise full-scale currents for sink and source modes, respectively (Figure 1).

A  $0.1\Omega$  resistor in the load return senses the output current and provides the LT1970 with feedback during current-limiting operation. With this sense resistance, setting the current-limit trimmers to 100% would allow the LT1970 to limit at approximately  $\pm 5\text{A}$ , but, because this application requires a 2A maximum current, you set the trimmers to approximately 40% rotation when calibrated. To prevent internal control contention at low output current, the LT1970 sets a minimum-current-limit threshold that corresponds to approximately 40 mA for the sense resistance. Another nice feature of the LT1970 is the availability of status flags, which, in this case, provide a simple means of driving a front-panel LED to indicate when current-limiting is active. The LT1970 features split power connections that allow you to power the internal output section independently from the analog-control portion. The flexibility of this configuration allows direct

sensing of the op amp's output current via resistance in the  $V+$  (Pin 19) and  $V-$  (Pin 2) connections. This feature gives a convenient means of establishing Class B operation of the MOSFET-output devices using a current-feedback method, in which the op-amp output current is converted to a gate-drive potential, thereby having the MOSFETs turn on only to the extent needed to help the op amp provide the output demand.

Because power supplies inherently must drive heavy capacitive loads—namely, circuits with high-value bypass capacitors—and any overvoltage could damage the circuit, pay careful attention

to compensating the op amp for minimal overshoot under all loading conditions. As with most op amps, the LT1970's inner- and outer-loop feedback accomplish capacitive-load tolerance. In this situation, the op amp itself is resistively decoupled from the load. The dc feedback for the LT1970 uses differential voltage sensing to eliminate the regulation error that would otherwise occur with the cur-

Schottky diode, such as a 1N5821 cathode, to the more positive connection, to the output binding posts. Alternatively, you could use a disconnect relay and power sequencer in the design to protect the load from any energetic reverse transients during turn-on and turn-off of the main bulk supply.

An adjustable power supply is an indispensable tool in any electronics lab. It

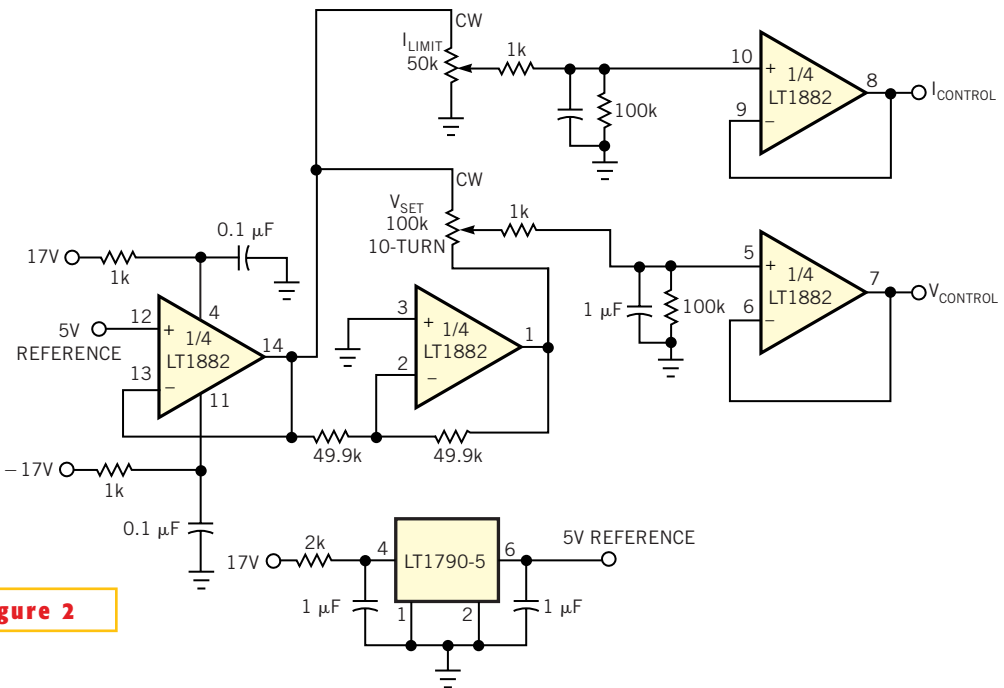

**Figure 2**

**The user-control section allows you to set the voltage range and current-limit parameters for the output section in Figure 1.**

rent-sense and lead resistances in series with the load. You can connect a pair of inexpensive digital panel meters to the output to monitor the output conditions in real time (Figure 1). (The two digital panel meters do not share “common” connections, which may complicate their powering.) Note that the selected current-sense resistance optimizes a digital-panel-meter display with the usual  $\pm 200\text{-mV}$  full-scale sensitivity to present as much as  $\pm 1.999\text{A}$ , for example. One word of caution: When you use this supply in place of a conventional single-quadrant supply to power sensitive electronics, it's good practice to connect a reverse-biased

can be even more useful in many circumstances if it provides the ability to adjust continually through 0V to the polarity, adjustably limit current, or both in either the source or the sink directions. These additional capabilities provide convenient methods of driving or loading circuits that are under development or test that might otherwise require very special or custom equipment, such as active-load units or dc-offset generators. You can readily obtain these features if you base the linear-regulator design on the versatile LT1970 power op amp, which includes built-in adjustable- closed-loop current-limiting functions. □

# Simple circuit controls stepper motors

Noel McNamara, Analog Devices, Limerick, Ireland

**S**TEPPER MOTORS are useful in many consumer, industrial, and military applications. Some, such as personal-transportation systems, require precise speed control. Stepper-motor controllers can be simple (Figure 1), but they require a variable-frequency square wave for the clock input. The AD9833 low-power DDS (direct-digital-synthesis) IC with an on-chip, 10-bit DAC is ideal for this task, because you need no external components for setting the clock frequency (Figure 2). The device contains

**Figure 1**

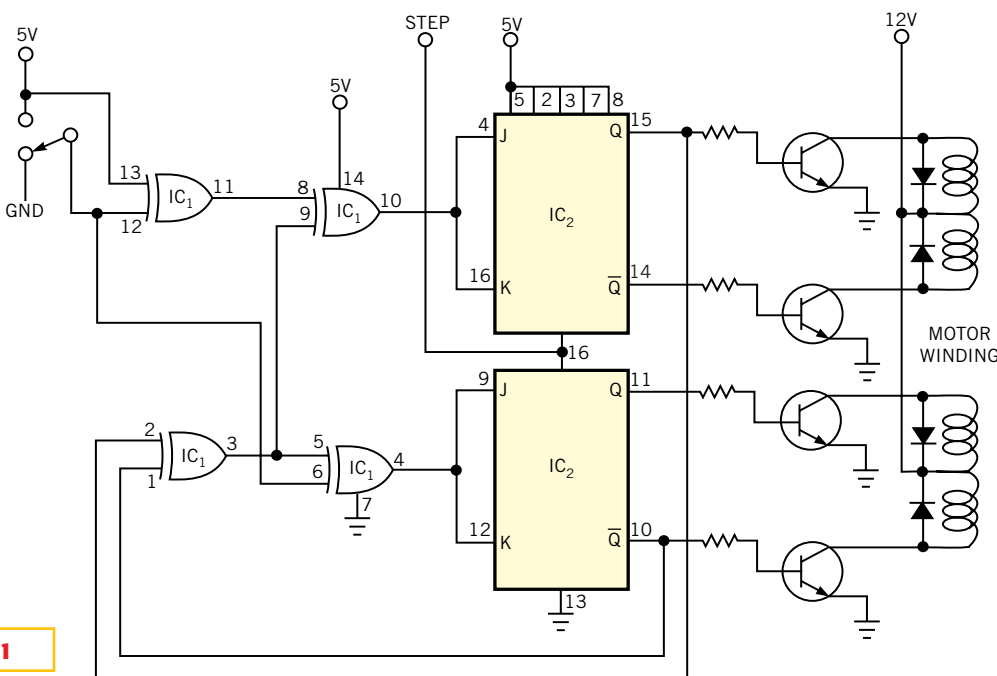

**A stepper-motor controller requires only a few logic circuits.**

**NOTES:** IC<sub>1</sub>: SN74HC86.  
IC<sub>2</sub>: SN74LS76A.

a 28-bit accumulator, which allows it to generate signals with 0.1-Hz resolution when you operate it with a 25-MHz MCLK (master clock). In addition, the circuit can easily stop the motor if you program a 0-Hz output frequency.

Figure 3 shows the complete system. The most significant bit of the on-chip DAC switches to the V<sub>OUT</sub> pin of the AD9833, thus generating the 0-to-V<sub>DD</sub>

square wave that serves as the clock input to the stepper-motor controller. Writing to the frequency-control registers via a simple, three-wire interface sets the clock

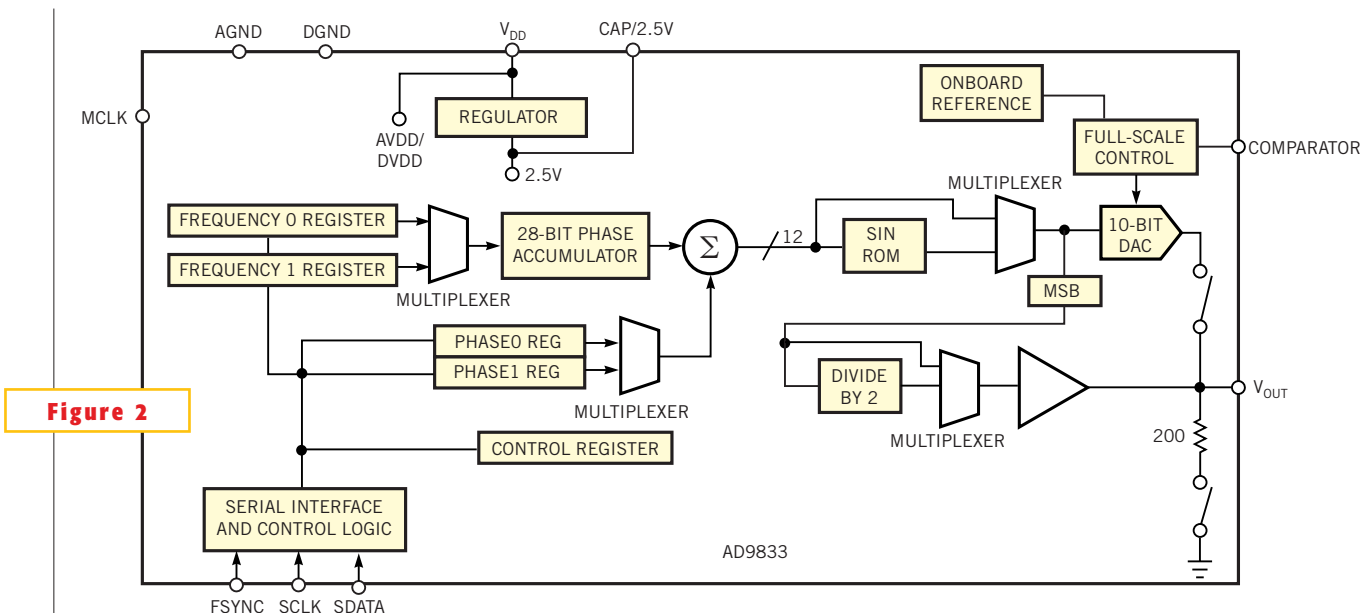

**Figure 2**

**The AD9833 DDS IC generates frequencies with 0.1-Hz resolution.**

frequency. Writing a 0 to the frequency register stops the clock, thereby stopping the stepper motor. When you are not using the DAC, you can power it down by writing to a control register. This power-down action results in the AD9833's drawing only 2 mA from the supply. Reducing the MCLK frequency can further reduce the supply current. The AD9833 is available in a tiny, 10-lead package, so you can assemble the complete control system on a very small pc board. □

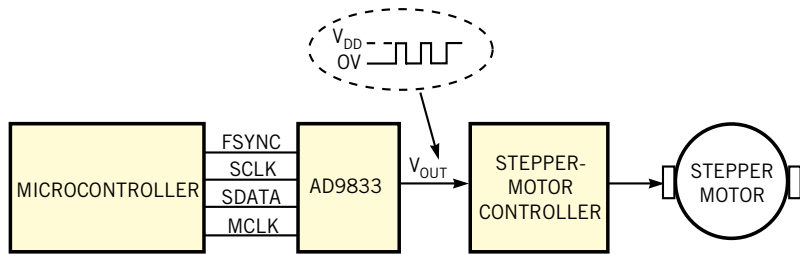

**Figure 3**

The complete stepper-motor controller uses a DDS IC to generate the variable frequencies for the circuit in Figure 1.

## Simple dc/dc converter increases available power in dual-voltage system

David Kim, Linear Technology, Milpitas, CA

THE SCHEMATIC in **Figure 1** shows a way to increase the power available from a current-limited 5V supply by adding power from a -5V supply. The dc/dc converter generates a single 12V, 150-mA (1.8W) output from two regulated and current-limited input sources at 5V, 300 mA (1.5W) and -5V, 300 mA (1.5W). Because the input uses different-polarity voltage sources, the design uses a flyback dc/dc converter to avoid a system-grounding problem. Level-shifted feedback sensing using a pnp transistor, Q<sub>1</sub>, references the feedback signal to the negative input voltage. You calculate the feedback-resistor divider by using the formula  $R_1 = R_4(V_{OUT} - V_{BE})/V_{REF}$ , where R<sub>1</sub> connects to the emitter of Q<sub>1</sub>, R<sub>4</sub> connects to the collector of Q<sub>1</sub>, V<sub>BE</sub> is the base-emitter voltage of Q<sub>1</sub>, and V<sub>REF</sub> is the feedback reference voltage of the switching regulator.

To simplify the circuit, the flyback converter in **Figure 1** uses an LT1946 monolithic switching regulator. The voltage rating of the monolithic regulator has to be greater than the maximum switching voltage of the flyback converter, calculated by  $[(V_{IN1} + |-V_{IN2}|)_{MAX} + V_{OUT(MAX)} / (T_1 \text{ turns ratio})] + V_{SPIKE}$ . The maximum switching voltage is approximately 25V for the circuit in **Figure 1**. Note also that

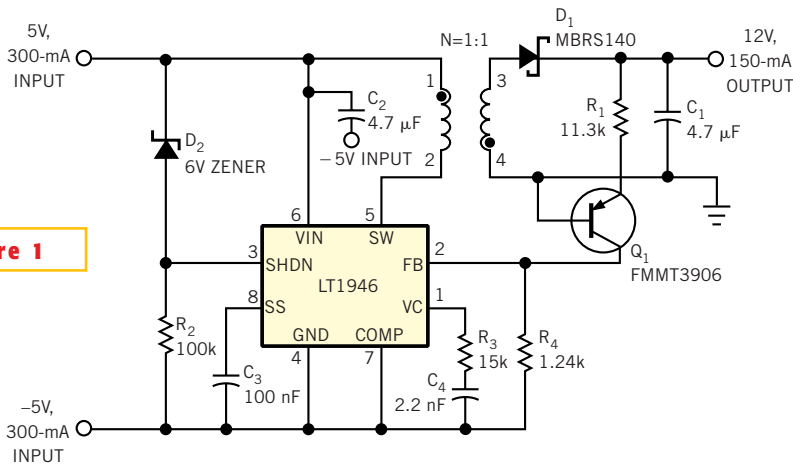

**Figure 1**

Combining two opposite-polarity power supplies can increase the available power from a flyback regulator.

the input capacitor and dc/dc regulator input must be able to handle a maximum input voltage of 10V, resulting from the calculation  $+V_{IN1(MAX)} + |-V_{IN2(MAX)}|$ . In an event of fault-current conditions, such as shorted input or output, a zener diode, D<sub>2</sub>, creates the undervoltage-lockout threshold to turn off the LT1946 whenever either input source is in current limit or the input voltage  $(+V_{IN1} + |-V_{IN2}|)$  drops below 6V to help the input supply recover when the fault condition is removed. In a system with two available

current-limited power supplies, you can convert the two supplies into a single supply that has more power-handling capability than either of the two inputs. A flyback topology based on an LT1946 monolithic converter offers a simple approach to the grounding problem and the feedback-sensing problem inherent in a dual-input power supply. Sharing the power between two input sources not only adds output-power capability, but also increases the overall flexibility of the system. □