

Edited by Bill Travis

Temperature-measurement scheme uses IR sensor and sigma-delta ADC

Albert O'Grady and Mary McCarthy, Analog Devices, Limerick, Ireland

MANY NONCONTACT temperature-measurement systems use infrared sensors, such as thermopiles, which can detect small amounts of heat radiation. Biomedical thermometers that measure the temperature of an ear or a temple use noncontact temperature measurement, as do automotive-HVAC systems that adjust temperature zones based on the body temperature of passengers. Household appliances and industrial processes can also benefit from the use of noncontact temperature measurement. Infrared thermometers can measure objects that move, rotate, or vibrate, measuring temperature levels at which contact probes either would not work or would have a shortened operating life. Infrared measurements do not damage or contaminate the surface of the item being measured. Thermal conductivity of the object being measured presents no problem, as would be the case with a contact temperature-measurement device. The circuit in Figure 1 provides a design for a high-resolution digital thermometer that uses a thermopile sensor and a sigma-delta

Figure 1

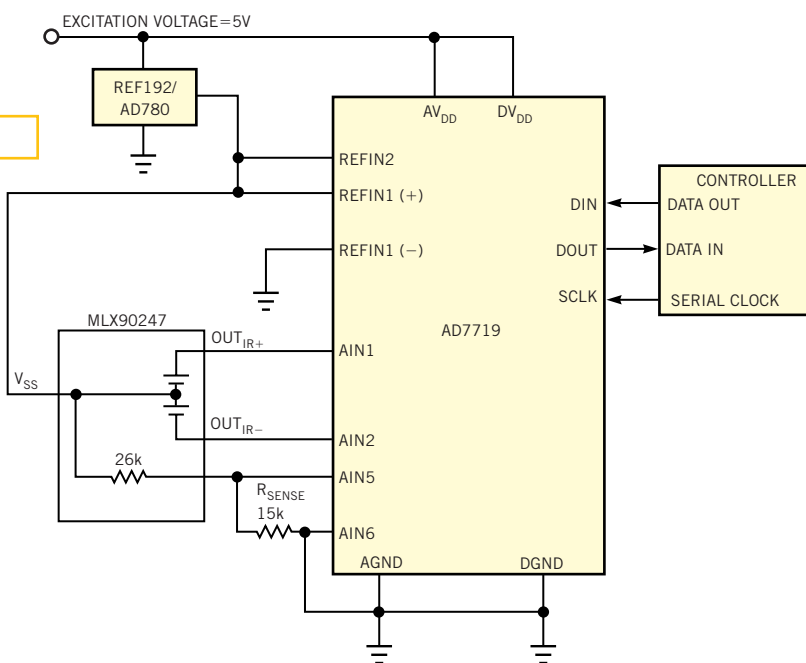

Using an infrared sensor and a sigma-delta ADC, you can make noncontact temperature measurements.

ADC. The design provides high resolution and response times of approximately 1 msec, and it eliminates the need for high-performance, low-noise signal conditioning before the ADC.

The high-accuracy, noncontact digital temperature measurement system uses the MLX90247D thermopile from Melexis (www.melexis.com) and the AD7719 high-resolution, sigma-delta ADC from Analog Devices (www.analog.com). The AD7719 provides differential inputs and a programmable-gain amplifier; thus, you can connect it directly to the sensor, allowing the temperature-measurement system to provide high accuracy without the need for pre-

cision signal-conditioning components preceding the ADC. The MLX90247D sensor comprises a thin, micromachined membrane embedded with semiconductor thermocouple junctions. The Seebeck-coefficient thermocouples generate a dc voltage in response to the temperature differential generated between the hot and the cold junctions. The low thermal conductivity of the membrane allows absorbed heat to cause a higher temperature increase at the center of the membrane than at the edge, thus creating a temperature difference that is converted to an electric potential by the thermoelectric effect in the thermopile junctions. The MLX90247D also con-

Temperature-measurement scheme uses IR sensor and sigma-delta ADC.....	65
Automotive link uses single wire.....	66
Novel idea implements low-cost keyboard.....	69
Get more power with a boosted triode	72
Anticipating timer switches before you push the button	74
Publish your Design Idea in EDN. See the What's Up section at www.edn.com.	

tains a thermistor, allowing you to configure a temperature-compensated system in relative-measurement mode.

The AD7719, a dual-channel, simultaneously converting ADC with an internal programmable-gain amplifier is an ideal ADC when you use it with the MLX90247D sensor in temperature-measurement applications. The main channel is 24 bits wide, and you can configure it to accept analog inputs of 20 mV to 2.56V at update rates of 5 to 105 Hz. The auxiliary channel contains a 16-bit ADC and accepts full-scale analog inputs of 1.25 or 2.5V with an update rate equal to that of the main channel. The AD7719 accepts signals directly from the sensor; the internal programmable-gain amplifier eliminates the need for high-accura-

cy, low-noise external-signal conditioning. The AD7719 simultaneously converts both the thermopile and the thermistor sensor outputs. The main channel with its programmable-gain amplifier monitors the thermopile, and the auxiliary channel monitors the thermistor. You can use on-chip chopping and calibration schemes in optimizing the design. The AD7719 features a flexible serial interface for accessing the digital data and allows direct interface to all controllers.

The sensitivity of the thermopile is 42 $\mu\text{V}/\text{K}$; thus, it produces an output voltage of 9.78 to 15 mV over the industrial temperature range of -40 to $+85^\circ\text{C}$, an output that the AD7719 can directly measure. The thermistor's impedance ranges

from 15.207 k Ω at -40°C to 38.253 k Ω at $+85^\circ\text{C}$ with a nominal impedance of 26 k Ω at 25°C . Again, you can directly measure voltages from the thermistor, as **Figure 1** indicates. Biomedical thermometers generally have a measurement range of 34 to 42°C . In this range, the thermopile's differential output is 336 μV . Operating the AD7719 in its $\pm 20\text{-mV}$ input range with a 5-Hz update rate allows temperature measurement with a resolution of 0.05°C .

Is this the best Design Idea in this issue? Select at www.edn.com.

Automotive link uses single wire

Anthony Smith, Scitech, Biddenham, Bedfordshire, UK

IN THE AUTOMOTIVE INDUSTRY, in which the goal is to produce cars with simpler, lighter wiring looms, any interface that uses just one wire instead of two offers a distinct advantage. The circuit in **Figure 1** implements a bidirectional link using a single wire, with the car's chassis or ground conductor providing a negative return path. The microcontroller communicates with the driver of the car by illuminating LED₁. The driver communicates by operating switch S₁. Detecting the switch closure requires no current sensing: The circuit simply exploits the fact that the forward voltage drop of a properly biased LED is usually two or three times the V_{BE} of a bipolar transistor. Q₁, LED₂, and Q₂ form a semiprecision current source. Q₃ in the receiver path detects the switch closure. When the microcontroller's TX pin goes high, Q₂ illuminates LED₂ and biases Q₁ on. Q₁ sources a constant current to LED₁ via R₂ and D₁.

LED₂ constitutes an inexpensive but effective voltage reference, which imposes a constant voltage across current-setting resistor R₁. Provided that you choose R₃'s value to suit Q₂'s base drive, you can set the current in LED₂ and the voltage

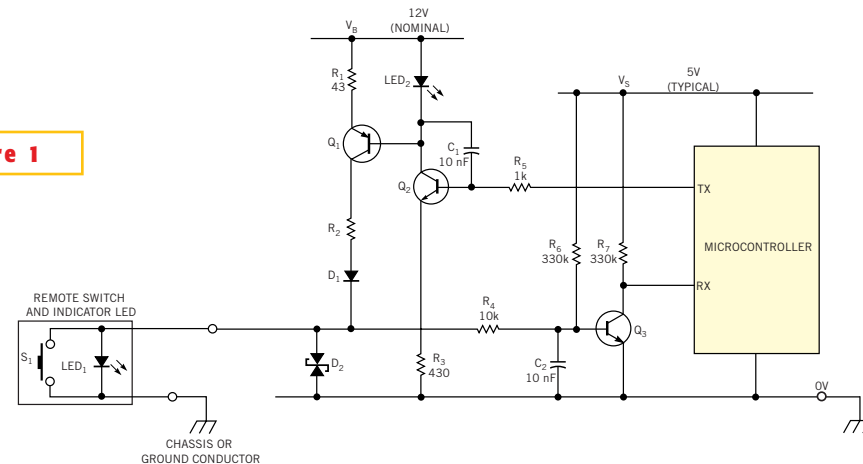

Figure 1

This circuit implements a bidirectional link using a single wire and a ground return.

across it to fairly precise and constant values. For example, with R₃=430 Ω , the current in LED₂ is approximately 10 mA with 5V at Q₂'s base (TX high). If you use a device such as the HLMP-1000 for LED₂, its forward voltage remains constant at approximately 1.6V, putting approximately 0.9V across R₁. The resulting 20 mA or so flowing in Q₁ provides adequate brightness for LED₁ and remains acceptably constant with changes in V_B or temperature.

With S₁ open, R₆ biases Q₃ on, pulling the receiver pin, RX, low. RX remains low, regardless of whether LED₁ is on. When the switch closes, the values for R₄ and R₆ ensure that Q₃'s base pulls down to approximately 150 mV (with V_S=5V), thereby turning off Q₃ and allowing RX to go high. As long as the switch remains closed, RX stays high, whatever the state of the TX pin. Powering the current source directly from the car's battery voltage, V_B, rather than from the microcon-

troller's supply, not only relieves the burden on the low-voltage regulator, but also ensures that LED₁ receives proper bias, even with a very low value for V_S. Thus, provided that R₃, R₄, and R₆ have appropriate values, the circuit functions with V_S as low as 3V or even lower. A further advantage is that you can replace LED₁ with several LEDs connected in series. With V_B = 12V, the current source has adequate compliance to drive four or five LEDs.

R₂ is a nonessential component, but it reduces the power consumption in Q₁. D₁ provides positive overvoltage protection for the current source, and voltage-suppressor D₂ can protect against the harmful transients that systems often en-

counter in the harsh automotive environment. C₂ with R₄ provides a degree of noise filtering and has negligible effect on the switching of Q₃. You may need C₁ and R₅ to roll off Q₂'s frequency response to avoid the possibility of high-frequency oscillation. The transistor types are not critical; most devices with respectable current gain and adequate power rating are satisfactory. LED₂ provides a triple function. As well as acting as a voltage reference for the current source, it also provides local indication of the external LED status by illuminating in synchronism with LED₁. Additionally, it provides open-circuit (broken-wire) indication by turning off completely (even when TX is high) if the connection between D₁ and

the external LED breaks—a feature that may be useful for troubleshooting purposes. In the event of a broken wire, little collector current flows in Q₁, and its base-emitter junction shunts LED₂; provided that R₁ is much smaller than R₃, the shunt steals LED₂'s bias current, thereby turning it off. Although the circuit was developed for an automotive product, you could easily adapt it for use in other applications in which a simple user interface must operate on a single line.

Is this the best Design Idea in this issue? Select at www.edn.com.

Novel idea implements low-cost keyboard

Jean-Jacques Thevenin, Thomson Plasma, Moirans, France

MANY APPLICATIONS that use a microcontroller also use a keyboard. If your application uses a relatively powerful microcontroller, you can use several free I/O pins or an unused input with an ADC to effect an easy keyboard connection. But, if the microcontroller in your system has too few free I/O pins and no on-chip ADC, you can be in trouble. However, if your system doesn't require a high-performance keyboard, you can solve the problem by using the circuit in **Figure 1**. How does it work? At system initialization, the I/O connection is an output, set to logic 0; hence, C is discharged. In reading the keyboard, the following steps take place:

1. I/O (output) assumes the state logic 1, V_{OUT}.
2. V_C charges to logic 1 (V_{OUT}) or to a voltage that R_S and the other resistors determines. (You can set the output I/O to logic 1 by default. In this case, you can omit steps 1 and 2, and the routine becomes faster. This design uses 0 instead of 1 to have an inactive signal on the line when the keyboard is not checked.)
3. I/O becomes an input.
4. For a duration T_{MAX}, the microcontroller checks the input I/O to see

Figure 1

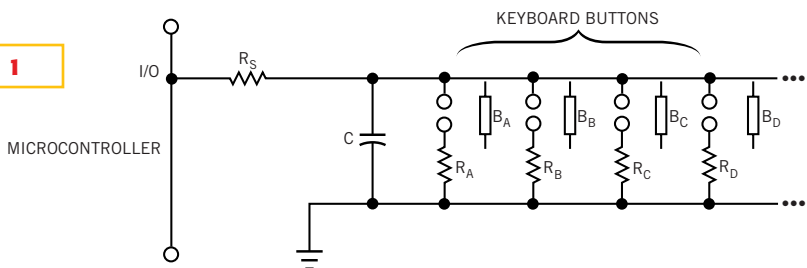

This circuit provides an inexpensive and easy way to read a small keyboard using only one I/O line of a microcontroller.

whether it resets to logic 0.

5. If, after T_{MAX}, the input I/O is still at logic 1, no button has been activated.

6. If within T_{MAX}, the input I/O resets to logic 0, the measured time indicates the activated buttons.

7. I/O becomes output again and resets to logic 0 to discharge C.

Several equations describe the operation of the scheme. First, assume some conditions: V_{OUT} is the voltage of the output I/O at logic 1; V_{TH} is the threshold for logic 0 input to the microcontroller; and R_X is the value of the parallel combination of R_A, R_B, and the other resistors.

Figure 2 shows the timing diagram for the circuit of **Figure 1**. You can evaluate

the duration of T_X with the following expression: T_X ≈ R_XC log_e (V_C/V_{TH}). If R_X is not negligible with respect to R_{XMIN} (but the R_{INPUT} of the microcontroller greatly exceeds R_X), then

$$T_X \approx R_X \cdot C \cdot \log_e \left(\frac{V_{OUT}}{V_{TH}} \cdot \frac{R_X}{(R_X + R_S)} \right),$$

where V_{OUT} is the voltage at logic 1 on the I/O output. From the last equation, a condition for R_X is:

$$R_{XMIN} > R_S \cdot \frac{V_{TH}}{V_{OUT} - V_{TH}}$$

Note that, if R_A, R_B, and the other re-

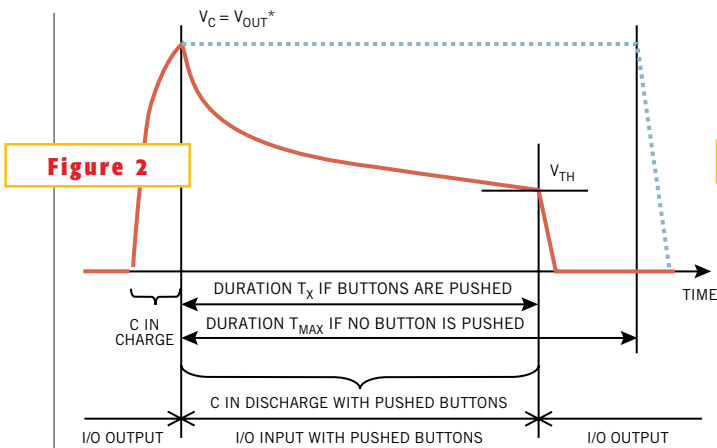

Figure 2

*IN FACT, IF SOME BUTTONS ARE PUSHED, $V_c = R_x / (R_x + R_s) \cdot V_{out}$.

The duration, T_x , indicates which buttons or combinations thereof you pushed.

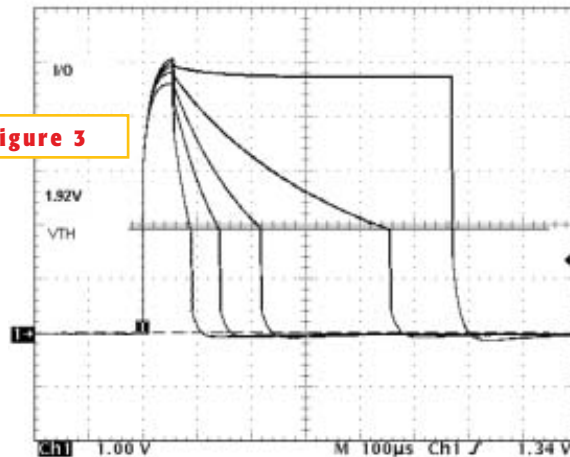

Figure 3

These waveforms at the I/O pin and table show the returned value (duration) with different combinations.

sisters form an R-2R string, R_{XMIN} is approximately equal to $R_A/2$. R_s limits the current from the microcontroller and must have a minimum value of V_{OUTMIN}/I_{OUTMAX} . This resistor creates a delay for charging and discharging C of approximately $5R_sC$. The following is an

example of a small keyboard with four buttons: To choose R_s , I_{OUTMAX} of the microcontroller is 25 mA at $V_{OUT}=5V$, so $R_{SMIN} \geq 200\Omega$. So this design uses $R_s=220\Omega$. R_A , R_B , R_C , and R_D are 1, 2.2, 3.9, and 8.2 k Ω , respectively. You can select values that greatly exceed R_s . In this

case, the effect of R_s is negligible, but you should then consider the effects of the input resistance of the microcontroller.

The duration between two measurements is approximately 2 μ sec (Listing 1). With one byte, the maximum duration, T_{MAX} , is 512 μ sec (when no button is pushed). So, time T_x with R_{XMAX} (in other words, R_D) must be inferior to T_{MAX} . Assuming that V_{TH} is 1.5V (minimum), the equation for T_x becomes

$$8200 \cdot C_{MAX} \cdot \log_e \left(\frac{5}{1.5} \cdot \frac{8200}{(8200 + 220)} \right) < 512 \mu\text{SEC} \rightarrow C_{MAX} < 53 \text{ nF.}$$

So, at the beginning of each measurement, you must append a delay of $5 \times 220\Omega \times 47 \text{ nF} = 52 \mu\text{sec}$ to charge C.

Figure 3 shows the waveforms at the I/O pin and the returned values with different button combinations. The power consumption of the circuit, with $C=47 \text{ nF}$, $V_{CC}=5V$, and a keyboard reading every 30 msec, is approximately 0.04 mW (practically negligible). You can use this scheme in all applications that don't require great accuracy or high speed. You can download Listing 1 from the Web version of this Design Idea at www.edn.com.

LISTING 1—THE DURATION BETWEEN TWO MEASUREMENTS

```

/*
 * Function : LittleKb_Scan with 1 I/O
 *
 * Description : scans the Little Keyboard
 *
 * Return value : 0 if not any touch is pushed
 *               else a value between 1 and 255
 *
 * Note :       by default, KB_IO is an output
 *               and its exit is set to 0 (see Note 1)
 */

BYTE LittleKb_Scan (void)
{
  BYTE bRet = 0;

  KB_IO = 1; // beginning ...
             // sets I/O (out) to 1 (see Note 1)
  Delay_us(55); // waits for 55us (see Note 1)

  KB_IO_Input(); // KB_IO is an input
  do
  {
    bRet++; // counter ++
    if(KB_IO == 0) // checks I/O (input)
      break;
  } while (bRet != 0); // the loop lasts 2us

  KB_IO = 0; // resets I/O to 0 (see Note 1)
             // KB_IO is an Output
             // and discharges C
  return bRet; // ... end
}

```

Is this the best Design Idea in this issue? Select at www.edn.com.

Get more power with a boosted triode

Dave Cuthbert, Boise, ID

EVEN THOUGH 6L6 beam-power tubes have been around for 66 years, they are still quite popular for use in electric-guitar amplifiers, and its cousin, the 6CA7 (EL34) power pentode, is a favorite among audiophiles. The developers of these tubes designed them for pentode-mode operation, and they deliver maximum audio power in this mode. On the other hand, many audiophiles prefer triode-mode operation and, until now, had to be content with a 50% reduction in output power. This reduction means that they require larger power supplies and twice as many expensive tubes to obtain pentode power from a triode amplifier. **Figures 1a, 1b, and 1c** show the 6L6 connected as a

pentode, a true triode, and a “boosted triode,” respectively. The boosted-triode configuration allows pentodes to produce pentodelike power while operating in a true-triode mode. To understand the operation of the boosted triode, it’s useful to review some vacuum-tube theory.

The 6L6 is a beam-power tube and has cathode, control-grid, screen-grid, suppressor-grid, and plate electrodes. The suppressor grid is actually a virtual sup-

pressor grid provided by two beam-forming plates, but you can treat the 6L6 beam-power tube as a pentode. You can think of a pentode as an n-channel JFET with the following electrode functions:

- Thermionic cathode: source of electrons (corresponds to the JFET source);
- Control grid: controls the cathode current; operated at a negative potential relative to the cathode (corresponds to the JFET gate);
- Screen grid: electrostatically screens the control grid from the plate, thereby reducing the effect that the plate voltage has on the cathode current; operates at a positive potential relative to the cathode;
- Suppressor grid: prevents secondary electrons from leaving the plate and traveling to the screen grid; operates at the cathode potential; and
- Plate: collects the electrons (corresponds to the JFET drain).

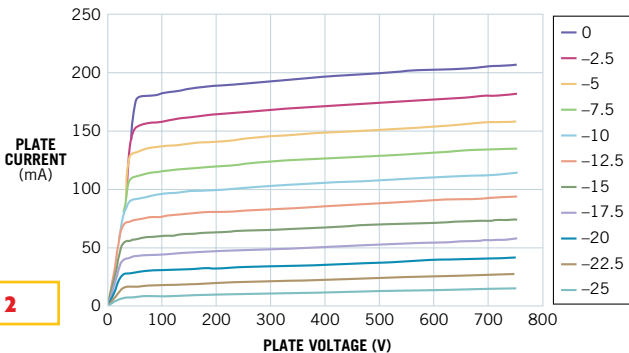

The load lines for a pentode show that the plate can draw 150 mA at a plate voltage of only 50V.

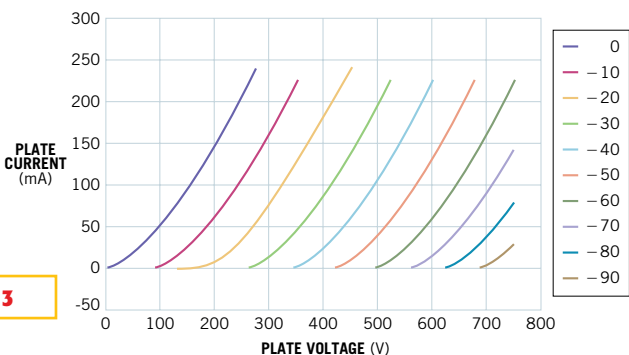

A pure triode needs 200V plate voltage to draw 150 mA.

Figure 2 shows the pentode’s characteristic curves for control-grid voltages of 0 to -25V and a screen-grid voltage of

Figure 1

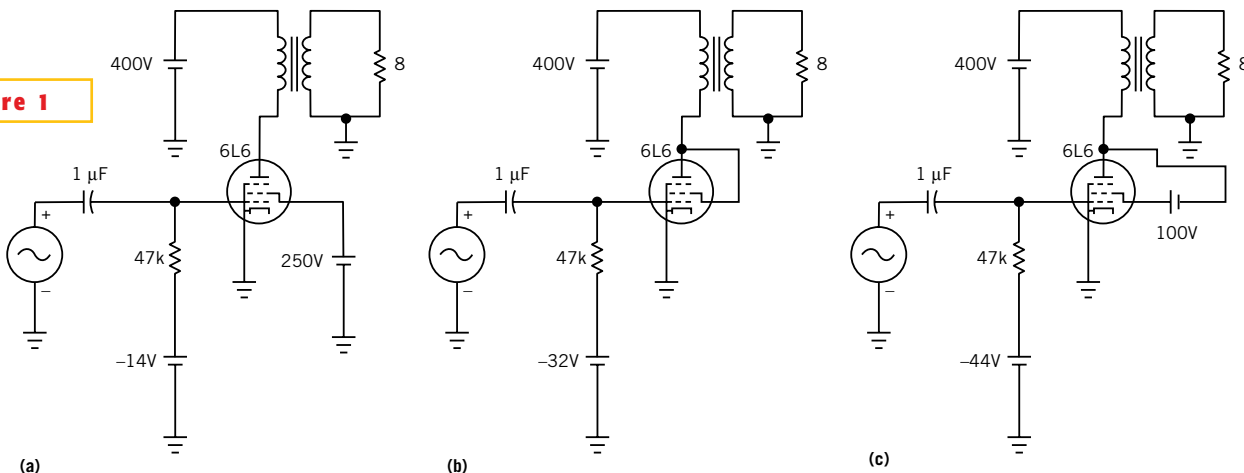

A pentode (a) can deliver much more power than a triode (b), unless you use a boosted-triode configuration (c).

250V. Note the idealized load line and that the tube can draw a plate current of 150 mA at a plate voltage of only 50V. High voltage gain, high plate impedance, and high output power characterize pentode-mode amplification. By connecting the screen grid directly to the plate, you can operate the tube in triode mode. Low voltage gain and low output impedance characterize this mode. **Figure 3** shows how the triode curves differ from the pentode curves. The curves represent control grid voltages of 0 to -90V. Note the load line and that, in triode mode, the

Amplifier	DC plate current (mA)	Grid bias (V)	Grid swing (V)	Output power (W)
Pentode	75	-14	22	11
Triode	75	-32	64	6
Boosted triode	75	-44	88	10

plate cannot draw 150 mA at a plate voltage lower than 200V. This fact greatly limits amplifier efficiency and power output. However, in spite of the limited output power, some people still prefer triode mode because they claim it produces a superior-sounding amplifier.

For the boosted-triode circuit in **Figure 1c**, you simply add a 100V screen-to-plate power supply (**Figure 4**) to the standard triode-amplifier circuit. This addition shifts the triode characteristic curves 100V to the left (**Figure 5**). Note the load line and that the plate can now draw 150 mA at a plate voltage of only 100V, rather than 200V as with the pure-triode-mode circuit. You can obtain significantly higher power with boosted-triode amplification and still maintain the characteristics of triode amplification. In Spice simulations of three single-ended Class A audio amplifiers using Micro-Cap-7 evaluation software (www.spectrum-soft.com), the control-grid bias for a quiescent plate current is 75 mA, and the ac grid signal is just short of amplifier clipping. The transformer ratios provide a plate-load impedance of 5 k Ω for the pentode and 3 k Ω for both the triode and the boosted triode. **Table 1** details the parameters.

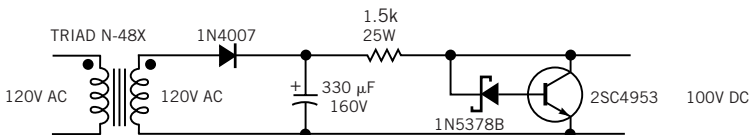

Figure 4

A 100V screen-grid power supply transforms a normal triode into a boosted triode.

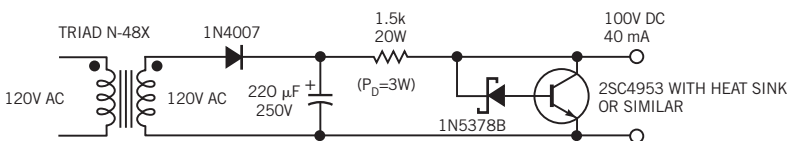

Figure 5

With a boosted triode, the plate can draw 150 mA with a plate voltage of 100V, versus 200V for a pure triode.

Is this the best Design Idea in this issue? Select at www.edn.com.

Anticipating timer switches before you push the button

Jean-Bernard Guiot, DCS AG, Allschwil, Switzerland

(Editor's note: This *Twilight Zone*-worthy circuit will be the subject of an upcoming network sitcom, *My Big Fat Anticipating Timer*.)

IT HAPPENS TO ALMOST EVERYONE that an apparatus or system should have been turned off *a moment ago*. The device in question could be the car heater, the air conditioner, the lights...

This Design Idea offers a solution to the challenge of turning devices on or off

in the past. In **Figure 1**, IC₂ is a 555-type timer (preferably CMOS) connected as a monostable one-shot multivibrator. The pushbutton switch, S₁, triggers IC₂. You can replace S₁ with a transistor or an optocoupler, for example. You can connect V_{OUT} to a relay or a transistor, if needed. You might need to adjust the values of R₄ and R₅, depending on the output load and the characteristics of S₁. The interval during which V_{OUT} remains high is

$T = 1.1RC_2$. In **Figure 1**, you replace the resistor, R, that normally connects to C₂ with the circuit inside the dashed line. This circuit comprises a 741 op amp, IC₁, and three resistors: R₁, R₂, and R₃. You could replace the war-horse 741 with a TL081 if your design needs longer time delays.

Taking into account the usual op-amp assumptions—equal voltage on both inputs and zero input current—you de-

rive the following expressions: $V_o = V(R_2 + R_1)/R_1$, and $V_o = V - R_3 I_c$, where V_o is the op amp's output voltage, V is the voltage at the noninverting input, and I_c is the current through R_3 . I_c is also the current that charges C_2 .

Combining the cited expressions, you can compute the value of resistor R that the op-amp circuit replaces: $R = V/I_c = -R_3 R_1 / R_2$. The timing interval of this timer is thus $T = -1.1 C_2 R_3 R_1 / R_2$. Using appropriate values, you can obtain long time delays that you can't attain with the basic 555 circuit. But the real innovation

inherent in this circuit is that its output turns on at a defined time, T , *before* you press S_1 . To adjust interval T , use a potentiometer for R_1 . Because the wiper of the potentiometer connects to the pow-

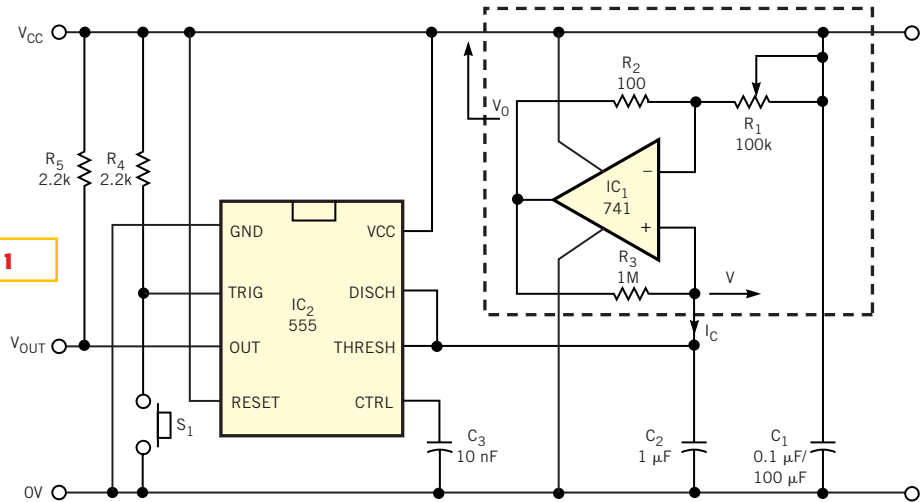

Figure 1

This innovative timer turns on approximately 18 minutes before you press switch S_1 .

er supply, adjusting R_1 contributes minimal EMI and other insidious effects to the op amp's input. C_1 is a power-supply bypass capacitor, and C_3 stabilizes the 555's control voltage. With the values

shown in **Figure 1**, the interval T is approximately 18 minutes.

Is this the best Design Idea in this issue? Select at www.edn.com.