

Edited by Bill Travis

Light a white LED from half a cell

Anthony Smith, Scitech, Biddenham, Bedfordshire, UK

WHETHER YOU USE them as indicators or to provide illumination, LEDs are hard to beat in efficiency, reliability, and cost. White LEDs are rapidly gaining popularity as sources of illumination, as in LCD backlights, but with forward voltages typically ranging from 3 to 5V, operating them from a single cell presents obvious difficulties. This design exploits the ultralow operating voltage of a single-gate Schmitt inverter, such as the Texas Instruments (www.ti.com) SN74AUC1G14 or the Fairchild (www.fairchildsemi.com) NC7SP14 (Figure 1). When you first apply battery power, Schottky diode D_1 conducts, and the familiar Schmitt-trigger astable multivibrator starts to oscillate at a frequency determined by timing components C_2 and R_1 . When IC_1 's output goes high, transistor Q_1 turns on, and current begins to ramp up in inductor L_1 . The maximum, or peak, level of inductor current is $I_{L(PEAK)} = (V_{BATT} - V_{CE(SAT)}) \times t_{ON} / L_1$, where V_{BATT} is the applied battery voltage, $V_{CE(SAT)}$ is Q_1 's saturation voltage, and t_{ON} is the duration of the high-level pulse at the Schmitt trigger's output. If Q_1 's saturation

voltage is, for example, less than 50 mV, you can ignore $V_{CE(SAT)}$ and simplify the expression to $I_{L(PEAK)} = V_{BATT} \times t_{ON} / L_1$.

At the end of t_{ON} , when the inverter output goes low, Q_1 turns off, and the voltage across L_1 reverses polarity. The resulting "flyback" voltage immediately raises Q_1 's collector voltage above V_{BATT} and forward-biases the LED and D_2 , which appear in series. This action illuminates the LED with a maximum forward current equal to $I_{L(PEAK)}$ and raises IC_1 's supply voltage, V_{BOOT} , to a diode drop above V_{BATT} . D_1 is now reverse-biased and remains so for as long as the circuit continues to oscillate. The resulting "bootstrapped" supply voltage for IC_1 ensures that the astable multivibrator continues to operate even when V_{BATT} falls to very low levels. You should choose values for C_2 and R_1 to produce a time constant of microseconds, thereby allowing a small inductance value for L_1 . For example, a test circuit using values of $C_2 = 68$ pF, $R_1 = 39$ k Ω , and $L_1 = 47$ μ H produces an operating frequency of approximately 150 kHz at $V_{BATT} = 1$ V. The resulting value of $t_{ON} = 3$ μ sec leads

Light a white LED from half a cell	87
LED driver delivers constant luminosity	88
Get more power with a boosted triode	90
White-LED driver touts high efficiency	92
Publish your Design Idea in EDN. See the What's Up section at www.edn.com.	

to a peak inductor current of approximately 65 mA and produces excellent brightness in the white LED. Even with V_{BATT} as low as 500 mV, the corresponding peak current of 33 mA produces reasonable LED intensity.

The inductance value should be as low as possible to maintain a high peak current and, hence, adequate LED brightness at the lowest supply voltage. However, L_1 should not be too small, or the peak current could exceed the LED's maximum current rating when V_{BATT} is at a maximum. Remember that the inductor should be adequately rated to en-

Figure 1

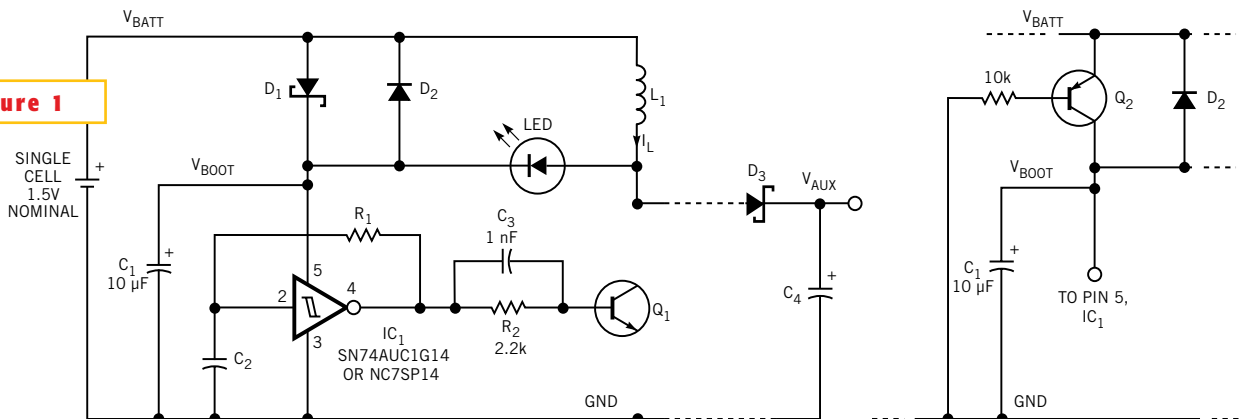

NOTES: D_1 AND D_3 ARE BAT42s OR SIMILAR.
 D_2 IS A 1N4148 OR SIMILAR.

(a)

(b)

This circuit produces dazzling intensity in a white LED from very low battery voltages (a). A modification allows even lower battery voltages (b).

sure it does not saturate at the highest value of peak current. Switching transistor Q_1 should have very low saturation voltage to minimize losses and produce the highest possible peak current. The addition of D_3 and C_4 enables the circuit to generate an auxiliary supply voltage, V_{AUX} , which you can use to drive low-power circuitry without adversely affecting the LED's intensity. With a battery voltage of 1V, the test circuit produces good light intensity in the white LED and delivers almost 1.5 mA at 4.7V to the auxiliary load. Even at $V_{BATT} = 500$ mV, the circuit delivers 340 μ A into a

10-k Ω load and maintains reasonable LED brightness. Note that IC_1 cannot take power from the auxiliary rail, because V_{AUX} can easily exceed the maximum voltage rating of the two suggested device types.

The minimum start-up voltage depends largely on the device you use for D_1 . Tests using a high-quality Schottky diode produce a minimum power-up voltage of just 800 mV. You can further reduce this level by replacing D_1 with pnp transistor Q_2 (Figure 1b). This modification allows the test circuit to start up at just 650 mV at room temperature. Note,

however, that Q_2 's collector-base junction becomes forward-biased under quiescent conditions, which results in wasted power in its base-bias resistor. Despite its simplicity, the circuit can produce spectacular results with high-brightness LEDs. The Luxeon range of LEDs from Lumileds (www.lumileds.com) allows the circuit to demonstrate its prowess. With L_1 reduced to 10 μ H and $V_{BATT} = 1$ V, the circuit generates a peak current of 220 mA in a Luxeon LXHL-PW01 white LED, resulting in dazzling light intensity. □

LED driver delivers constant luminosity

Israel Schleicher, Bakersfield, CA

THE CIRCUIT IN Figure 1 is similar in principle to that of a previous Design Idea (Reference 1) but offers improved, more reproducible performance. The output current is almost constant over an input-voltage range of 1.2 to 1.5V and is insensitive to variations of transistor gain. Transistors Q_1 and Q_2 form an astable

flip-flop. R_1 and C define the on-time of Q_2 . During that time, Q_1 is off, and the voltage at the base of Q_1 and the current in inductor L ramp up. When the voltage at the base of Q_1 reaches approximately 0.6V, Q_1 turns on, and Q_2 turns off. This switching causes "flyback" action in inductor L . The voltage across the inductor reverses, and the energy stored in the inductor transfers to the LED in the form of a down-ramping pulse of current. During flyback time, voltage across the LED is approximately constant.

The voltage for yellow and white LEDs is approximately 1.9 and 3.5V, respec-

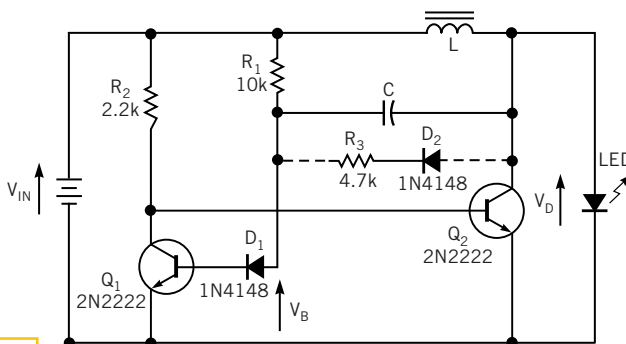

Figure 1

NOTE:
WHITE LED REQUIRES R_3 AND D_2 .

This circuit delivers virtually constant luminosity for a white or a yellow LED.

tively. When the current through the LED falls to zero, the voltage at the collector of Q_2 falls sharply, and this circuit condition triggers the next cycle. Assuming the justifiable approximation that the saturation voltage of Q_2 is close to 0V and that the LED's forward voltage, V_D , is constant, you can easily derive the expression for the average dc current through the LED:

$$I_{AVE} = \frac{V_{IN}^2 R_1 C}{2V_D L} \log_e \left(\frac{V_{IN} + V_D - V_B}{V_{IN} - V_B} \right)$$

At first glance, I_{AVE} depends strongly on V_{IN} . But close examination of the logarithmic term reveals that, with a proper selection of V_B , the logarithmic term can become a sharply declining function of V_{IN} . The logarithmic term thus fully compensates for the term V_{IN}^2 in the expression. That compensation is precisely the purpose of the diode, D_1 , in series with the base of Q_1 . The circuit drives a high-brightness yellow or white LED. Table 1 shows the proper component selection for both colors. Table 1 also shows some measured results at $V_{IN} = 1.35$ V. Because the voltage across the white LED falls from 3.9 to 3.1V during flyback, capacitor C subtracts current from the amount available to the base of Q_1 . This subtraction might retrigger the circuit before the current in L falls to zero. The addition of R_3 and D_2 solves this problem. During flyback, the current that flows through R_3 compensates for the current withdrawn through C . □

selection for both colors. Table 1 also shows some measured results at $V_{IN} = 1.35$ V. Because the voltage across the white LED falls from 3.9 to 3.1V during flyback, capacitor C subtracts current from the amount available to the base of Q_1 . This subtraction might retrigger the circuit before the current in L falls to zero. The addition of R_3 and D_2 solves this problem. During flyback, the current that flows through R_3 compensates for the current withdrawn through C . □

TABLE 1—COMPONENT SELECTION FOR YELLOW OR WHITE LED

LED	L (mH)	C (pF)	D_1	Current drain (mA)	LED current (mA)	Frequency (kHz)	Power-conversion efficiency (%)
Yellow	1	470	1N4003	5.6	3.3 ± 0.1	40	83
White	2	1800	1N752	12.4	3.7 ± 0.2	15	78

REFERENCE

1. Nell, Susanne, "Voltage-to-current converter drives white LEDs," *EDN*, June 27, 2002, p. 84.

Get more power with a boosted triode

Dave Cuthbert, Boise, ID

THIS DESIGN IDEA is a reprint of an earlier one that contained errors in graphics (Reference 1). Even though 6L6 beam-power tubes have been around for 66 years, they are still quite popular for use in electric-guitar amplifiers, and its cousin, the 6CA7 (EL34) power pentode, is a favorite among audiophiles. The developers of these tubes designed them for pentode-mode operation, and they deliver maximum audio power in this mode. On the other hand, many audiophiles prefer triode-mode operation and, until now, had to be content with a 50% reduction in output power. This reduction means that they require larger power supplies and twice as many expensive tubes to obtain pentode power from a triode amplifier. **Figures 1a, 1b, and 1c** show the 6L6 connected as a pentode, a

Amplifier	DC plate current (mA)	Grid bias (V)	Grid swing (V)	Output power (W)
Pentode	75	-14	22	11
Triode	75	-32	64	6
Boosted triode	75	-44	88	10

true triode, and a “boosted triode,” respectively. The boosted-triode configuration allows pentodes to produce pentodelike power while operating in a true-triode mode. To understand the operation of the boosted triode, it’s useful to review some vacuum-tube theory. The 6L6 is a beam-power tube and has cathode, control-grid, screen-grid, suppressor-grid, and plate electrodes. The suppressor grid is actually a virtual suppressor grid provided by two beam-forming plates, but you can treat the 6L6

beam-power tube as a pentode. You can think of a pentode as an n-channel JFET with the following electrode functions:

- Thermionic cathode: source of electrons (corresponds to the JFET source);
- Control grid: controls the cathode current; operated at a negative potential relative to the cathode (corresponds to the JFET gate);
- Screen grid: electrostatically screens the control grid from the plate, thereby reducing the effect that the plate voltage has on the cathode current; operates at a

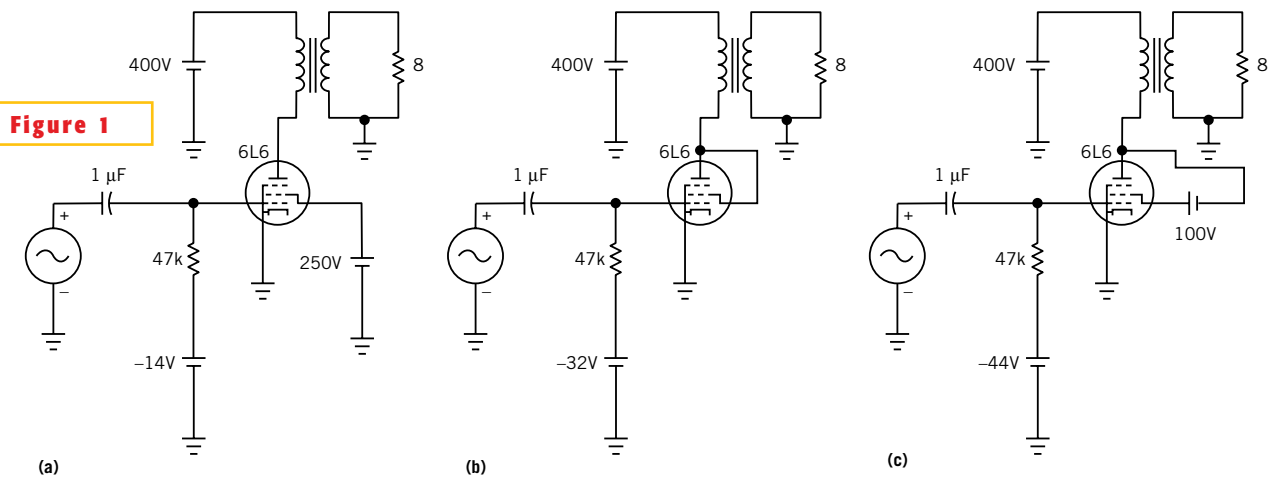

A pentode (a) can deliver much more power than a triode (b), unless you use a boosted-triode configuration (c).

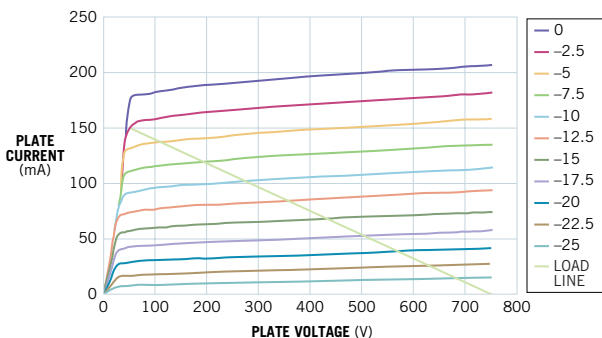

Figure 2 The load lines for a pentode show that the plate can draw 150 mA at a plate voltage of only 50V.

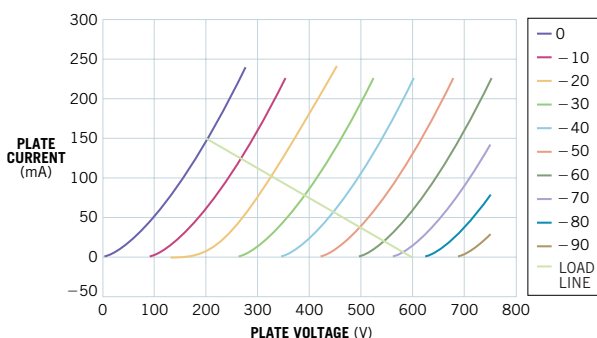

Figure 3 A pure triode needs 200V plate voltage to draw 150 mA.

positive potential relative to the cathode;

- Suppressor grid: prevents secondary electrons from leaving the plate and traveling to the screen grid; operates at the cathode potential; and

- Plate: collects the electrons (corresponds to the JFET drain).

Figure 2 shows the pentode's characteristic curves for control-grid voltages of 0 to -25V and a screen-grid voltage of 250V . Note the idealized load line and that the tube can draw a plate current of 150 mA at a plate voltage of only 50V . High voltage gain, high plate impedance, and high output power characterize pentode-mode amplification. By connecting the screen grid directly to the plate, you can operate the tube in triode mode. Low voltage gain and low output impedance characterize this mode. Figure

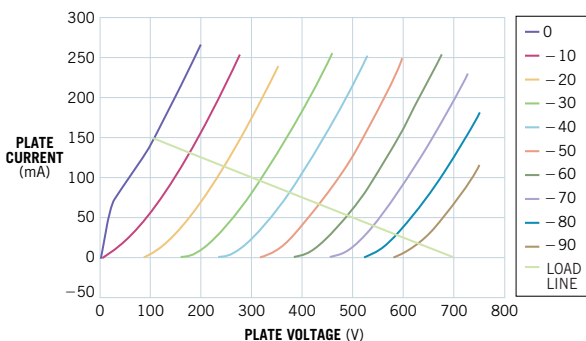

Figure 5

With a boosted triode, the plate can draw 150 mA with a plate voltage of 100V versus 200V for a pure triode.

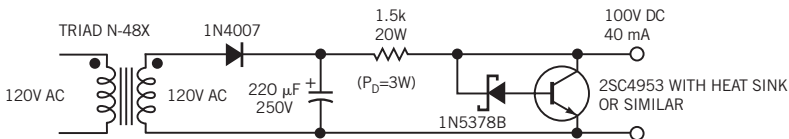

Figure 4

A 100V screen-grid power supply transforms a normal triode into a boosted triode.

3 shows how the triode curves differ from the pentode curves. The curves represent control-grid voltages of 0 to -90V . Note the load line and that, in triode mode, the plate cannot draw 150 mA at a plate voltage lower than 200V . This fact greatly limits amplifier efficiency and power output. However, in spite of the limited output power, some people still prefer triode mode because they claim that it produces a superior-sounding amplifier.

For the boosted-triode circuit in Figure 1c, you simply add a 100V screen-to-plate power supply (Figure 4) to the standard triode-amplifier circuit. This addition shifts the triode characteristic curves 100V to the left (Figure 5). Note the load line and that the plate can now draw 150 mA at a plate voltage of only

100V , rather than 200V as with the pure-triode-mode circuit. You can obtain significantly higher power with boosted-triode amplification and still maintain the characteristics of triode amplification. In Spice simulations of three single-ended Class A audio amplifiers using MicroCap-7 evaluation software (www.spectrum-soft.com), the control-grid bias for a quiescent plate current is 75 mA , and the ac grid signal is just short of amplifier clipping. The transformer ratios provide a plate-load impedance of $5\text{ k}\Omega$ for the pentode and $3\text{ k}\Omega$ for both the triode and the boosted triode. Table 1 details the parameters. □

REFERENCE

1. Cuthbert, Dave, "Get more power with a boosted triode," *EDN*, April 3, 2003, pg 72.

White-LED driver touts high efficiency

Dimitry Goder, Sipex Corp, San Jose, CA

WHITE LEDs, the most recent addition to the LCD backlight, find common use in providing backlight for color LCDs. Thanks to their size and white-light output, they appear in small, portable devices with color displays, such as PDAs and cellular phones. Like other LEDs, a white LED needs a constant-current source—typically, on the order of 15 to 20 mA . The forward voltage of a white LED is approximately 3.5V . Most products use multiple LEDs to provide adequate backlight for a display. Because the LED's brightness depends on its forward current, these multiple diodes commonly

connect in series to ensure that the same current flows through each of them. You need approximately 14V to forward-bias four series-connected LEDs, starting from the nominal operating voltage, 2.7 to 4.2V , of a single-cell lithium-ion battery. Boost regulators usually provide this operating voltage. A current-sense resistor, which you insert in series with the LEDs, closes the feedback loop. However, it is important to minimize the voltage drop across this resistor to increase efficiency. Currently available integrated boost regulators commonly use a 1.24V bandgap voltage as the feedback reference, which results in

1.24V loss across the current-sense resistor, a loss that represents approximately 7% loss in efficiency. Figure 1 shows an interesting LED-drive circuit.

You use the SP6682, a standard, regulated charge-pump circuit, in an unusual manner to control the external switch, Q_1 . This IC incorporates an internal 500-kHz oscillator, which would normally drive charge-pump capacitors to double the input voltage. The circuit in Figure 1 uses no charge-pump capacitors. Instead, the oscillator output appears on Pin 7 and drives Q_1 on and off. Q_1 , L_1 , D_1 , and C_1 function as a conventional boost reg-

ulator, which builds up voltage across C_1 . When this voltage exceeds the sum of the diodes' forward drop, current starts to flow. The circuit senses current across R_1 and compares it with a 0.3V reference voltage inside the chip. This circuit pro-

vides efficiencies as high as 87%, a figure that exceeds that of any integrated boost regulator. Several factors are responsible for the increased efficiency. First, the chip integrates the 0.3V reference voltage, which is significantly lower than the typ-

ical 1.24V. This reference voltage appears in series with the LEDs and therefore constitutes an efficiency loss proportional to the value of the reference. Second, a discrete MOSFET provides low on-resistance and high switching speed, parameters superior to those of any integrated switch.

Q_1 is a low-cost device that comes in a tiny SOT-23 package. Also, the excellent drive capability of the charge-pump IC ensures low switching losses. By changing the type of the MOSFET you use, you can make a trade-off between desired efficiency and cost. The breakdown voltage of the MOSFET limits the maximum output voltage; you can adjust the voltage to drive a system with as many LEDs as you need. (Larger displays use eight to 12 LEDs.) For dimming purposes, applying a PWM signal to the Enable pin causes the regulator to shut down and restart. This function allows you to precisely control LED brightness. □

Figure 1

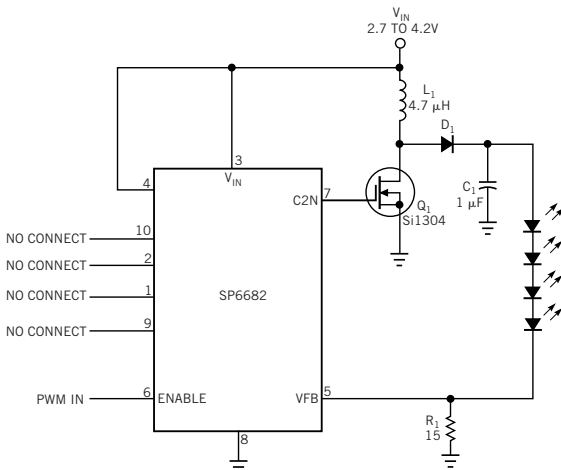

This circuit uses a charge-pump IC to provide power to a series string of LEDs.