

Edited by Bill Travis

## Clip extracts signal from phone line

Maxwell Strange, Fulton, MD

USING A capacitive-coupled clip, you can pick up the signal from a twisted-pair or -wire telephone line or from other unshielded analog lines without piercing the insulation. No line test can detect the clip's presence, and it leaves no evidence of having been attached. It

needs no ground return. You can fasten the small, insulated pickup plates to the opposing jaws of an alligator clip for quick and easy attachment. Balanced lines from the plates connect to the inputs of a high-impedance differential amplifier (Figure 1). For this scheme to have satisfactory signal-to-noise and frequency-response parameters, the clip, connecting cable, and amplifier must be attached parallel to the signal wire and must be as long

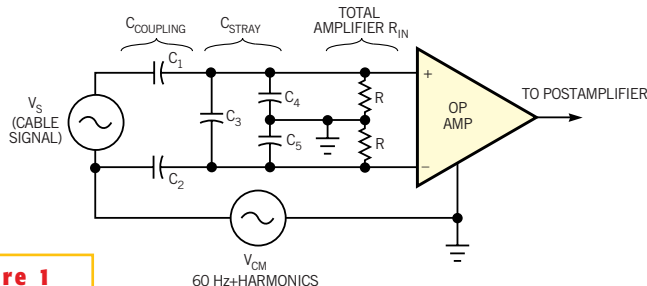

**Figure 1**

In this equivalent circuit, you should maximize the coupling capacitances,  $C_1$  and  $C_2$ , and minimize the stray capacitances,  $C_3$ ,  $C_4$ , and  $C_5$ .

interference, typically comprising 60-Hz signals and their harmonics from power-line fields. The cable should have good electrical symmetry and low total capacitance between conductors and to the shield. Thus, the amplifier must be near the clip. The amplifier should have high input resistance, low current noise, and adequate common-mode rejection.

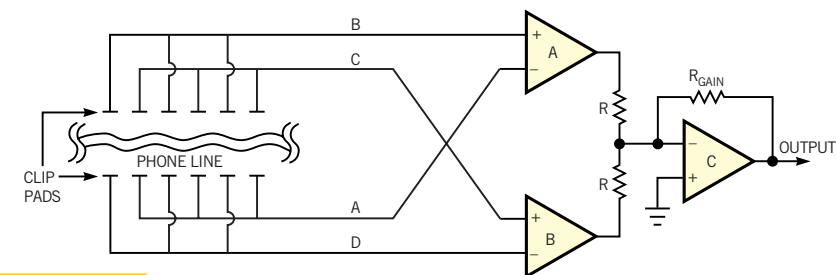

**Figure 2**

A multiple-pad approach produces cancellation of equal noise that the opposed pad pairs pick up.

as is conveniently possible—an inch or more—and preferably slightly curved to maximize the coupling capacitance. (For a twisted-conductor line, the plates should not be longer than the twist “wavelength” to avoid signal cancellation.) You should orient the clip for the cleanest signal output.

The clip, its connecting cable, and the amplifier must be shielded to minimize

The clip’s coupling capacitance and stray capacitance and the amplifier’s input resistance determine the low-frequency cutoff of the detected signal. Stray capacitances in the clip and in its connecting cable to the shield are generally much larger than the coupling capacitance. Thus, voltage-divider action reduces the signal, but the stray component adds to the capacitance the amplifier’s in-

put sees and reduces the circuit’s noise by the square root of the signal attenuation. The noise reduction accrues from reducing the needed input resistance. Therefore, you generally don’t need the complication of an insulated “bootstrapped” shield. You can follow the amplifier with a nearby or remotely located post-amplifier for more gain and bandpass filtering to optimize the signal-to-noise performance.

A telephone signal has a bandwidth of approximately 300 Hz to 3 or 4 kHz. A sharp highpass cutoff at 300 Hz effectively rejects power-line noise pickup. A simple, two-pole, Sallen-Key Butterworth filter works well. You can trim it to provide some high-frequency peaking to obtain the most intelligible signal.

A multiple-pad pickup scheme improves noise rejection (Figure 2). The circuit’s arrangement is such that even-numbered pads on one side and odd-numbered pads on the other side pick up equal noise that produces opposite-phase outputs from op amps A and B. Op amp C then sums the signals and rejects the noise. The desired difference signal, however, appears in-phase at the outputs of A and B, so both op amps con-

Clip extracts signal from phone line.....	81
Circuit produces variable frequency, duty cycle .....	82
Active-feedback IC serves as current-sensing instrumentation amplifier .....	86
Create secondary colors from multicolored LEDs.....	88

**Publish your Design Idea in EDN. See the What’s Up section at [www.edn.com](http://www.edn.com).**

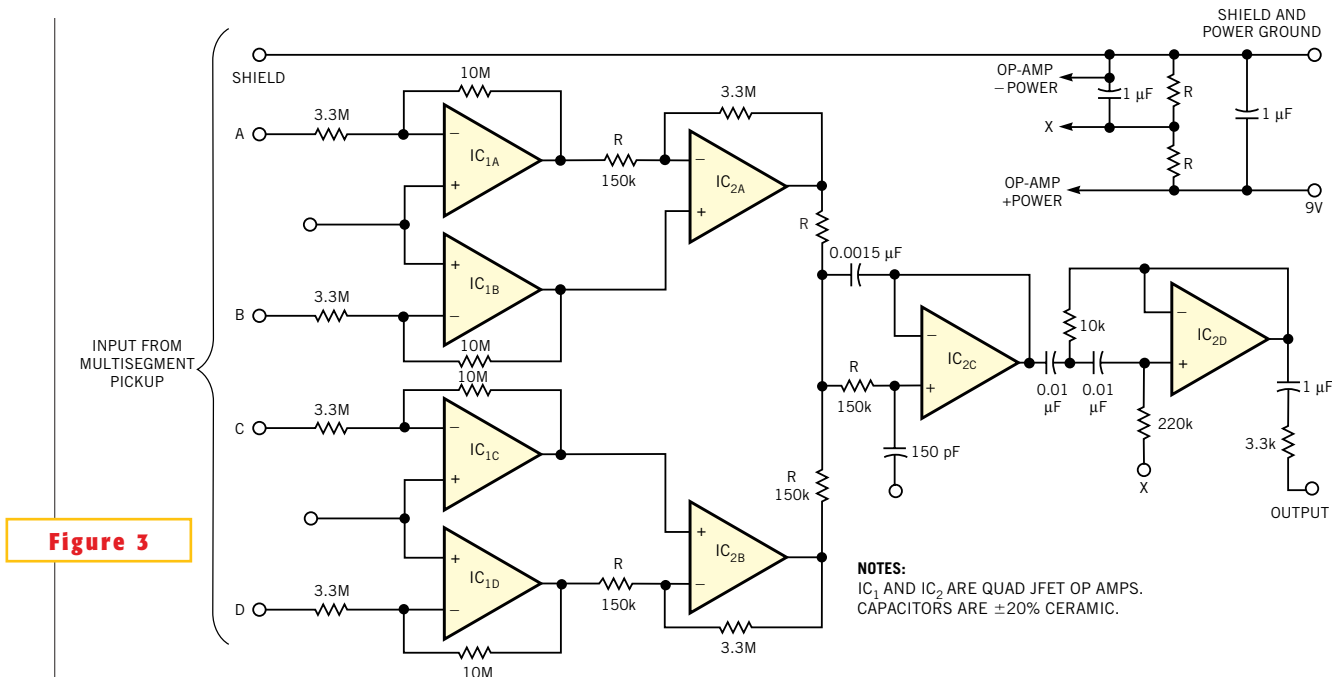

**Figure 3**

This amplifier, using the multiple-pad approach effectively reduces power-line-related noise pickup.

tribute equally to the output. You can make a segmented pickup from pieces of two-sided pc board with the solid-copper side serving as a shield. You can solder the shield side of the pieces to a suitable alligator clip. Alternatively, for longer term use, you can simply tape them onto the cable. You can use any even number of pads. The more you use, the better, but eight on each side are sufficient.

The amplifier of **Figure 3** uses two quad J-FET or BiFET op amps. Thanks to

stray capacitance on the input lines of the test model, a relatively low input resistance of 3.3 MΩ is sufficient. Input noise is mostly the Johnson noise of the 10-MΩ feedback resistors. Power-line noise pickup is usually the bigger problem. The output stages incorporate some highpass filtering to reject noise below 300 Hz. The output level depends on many factors but is approximately 50 mV. A postamplifier (not shown) can provide more equalization, filtering, and gain if necessary, as

well as manual or automatic level control. Tests of models of both design approaches use readily available components and show perfectly clear telephone speech through a small speaker in the postamplifier box. The multiple-pad pickup system produces noticeably lower noise, and clip orientation is less critical. □

## Circuit produces variable frequency, duty cycle

Mark Reed, Texas Instruments, Dallas, TX

**T**HIS DESIGN IDEA shows a simple, low-cost circuit that produces a highly accurate variable-frequency and variable-duty-cycle output (**Figure 1**). Further, the duty cycle and frequency are independent of each other (excluding 0 and 100% duty cycle). The method derives its accuracy and stability from the fact that the output is based on a crystal oscillator and divisions of the oscillator's frequency. The design uses only six de-

vices. IC<sub>1</sub>, a 74HC393 binary ripple counter, has as its input is the oscillator's output frequency. The outputs are the oscillator frequency divided by two, four, eight, 16, 32, 64, 128, and 256. IC<sub>5B</sub> is cascaded with IC<sub>1</sub> to divide the oscillator frequency further by 512, 1024, 2048, and 4096. In this circuit, the divide-by-128 is the largest division it uses. You could, with a simple wiring change, substitute an unused divider to obtain a different

output-frequency range. The eight inputs of IC<sub>2</sub>, a 74HC151 eight-line-to-one-line multiplexer, connect to the oscillator's frequency divided by one, two, four, eight, 16, 32, 64, and 128. Note that the oscillator's output connects directly to an input of IC<sub>2</sub>. This connection allows selecting the oscillator's frequency divided by one. IC<sub>2</sub> connects one of the eight frequencies to the input of IC<sub>3</sub>.

IC<sub>3</sub>, a 74HC4017 decade counter, di-

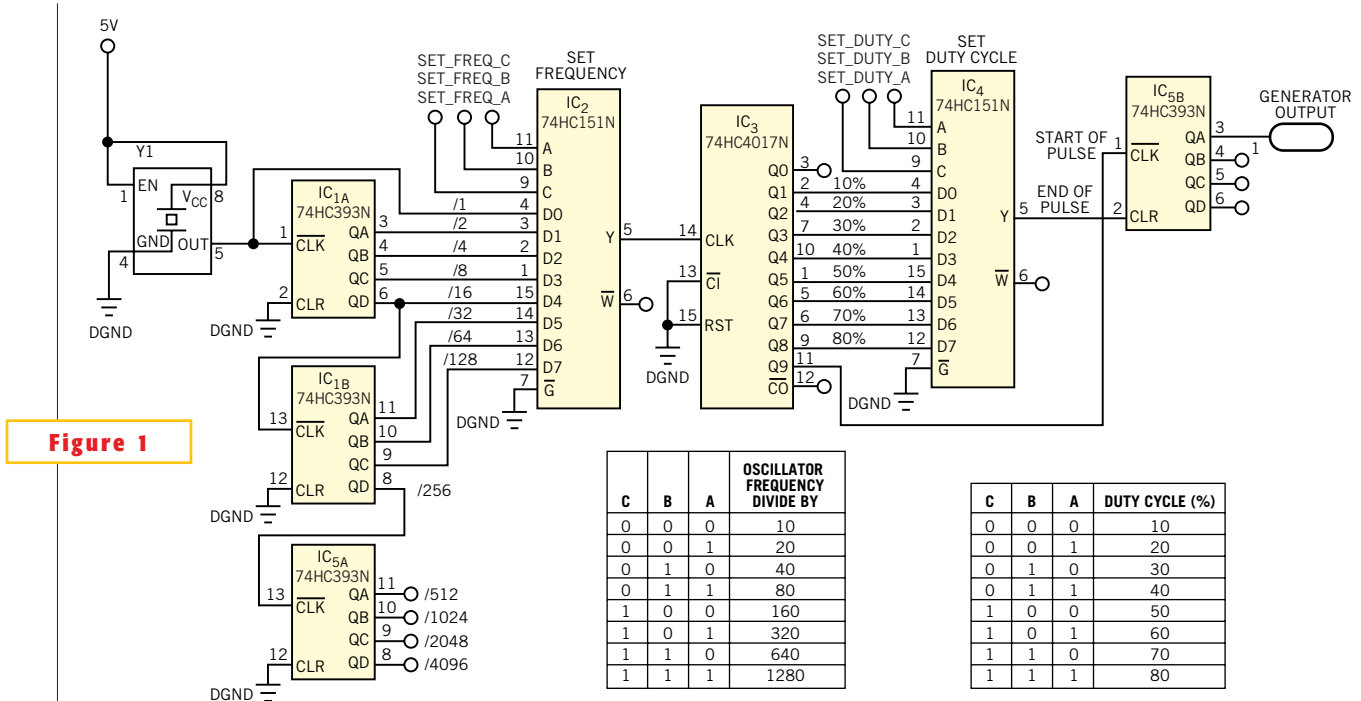

Figure 1

This circuit produces waveforms of variable frequency and duty cycle. Further, the frequency and duty cycle are independent of each other.

vides the frequency from IC<sub>2</sub>'s output by 10. Therefore, the maximum output frequency for this design is the oscillator frequency divided by 10. Each of the decoded decade counter's 10 outputs goes high for one clock cycle only (Figure 2). Using the 10 outputs, a frequency's period divides into 10 equal intervals. You can use these 10 equal intervals to generate duty cycles of 10, 20, 30, 40, 50, 60, 70, 80, and 90%. For this circuit, the outputs of IC<sub>3</sub>, Q1 through Q8, yield the end-of-pulse signals for duty cycles of 10 through 80%, respectively. The start-of-pulse signal is Q9's negative edge, which occurs at the same time as Q0's positive edge. Therefore, you can use Q9 as start-of-pulse low true, and the end-of-pulse signals are high true. The eight inputs of IC<sub>4</sub>, an eight-line-to-one-line multiplexer, connect to eight of the nine end-of-pulse outputs from IC<sub>3</sub>. This circuit omits the 90% duty cycle. You can include the 90% duty cycle with a simple

wiring change. If you want to select 0% duty cycle, connect an input to IC<sub>4</sub>. If you select 0% duty cycle, the generator's output is low. IC<sub>4</sub> connects one of eight end-of-pulse signals to IC<sub>5</sub>.

IC<sub>5A</sub> is a binary ripple counter that serves as a set-reset latch. The start-of-pulse signal sets the latch. The end-of-pulse signal resets the latch. The output of IC<sub>5</sub> is the variable-frequency and variable-duty-cycle output of the signal generator. For example, if the oscillator's frequency is 4 MHz and IC<sub>2</sub>'s C B A inputs are 0 1 0, then the generator delivers 100 kHz. If IC<sub>4</sub>'s C B A inputs are 0 0 1, then the generator's output exhibits 20% duty cycle. If you need to select from more than eight frequencies, use a larger multiplexer than IC<sub>2</sub>. Cascade more or different types of dividers to achieve your frequency needs. You can use a 74HC390 to obtain division by five, 10, 50, 100, and so on. If you need other duty cycles, cascade 74HC4017s to divide the period by the desired number of intervals. Finally, if you need to select from more than eight duty cycles, use a larger multiplexer than IC<sub>4</sub>. □

Figure 2

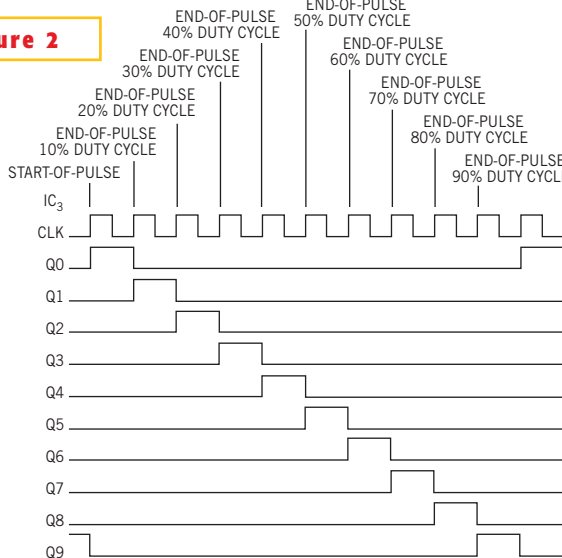

The end-of-pulse signals from IC<sub>3</sub> determine the duty cycle of the output waveform.

# Active-feedback IC serves as current-sensing instrumentation amplifier

Jonathan Pearson, Analog Devices, Wilmington, MA

**H**IGH-SPEED current sensing presents a designer with some significant challenges. Most techniques for sensing current involve measuring the differential voltage the current produces as it flows through a sense element, such as a resistor or a Hall-effect device. The differential voltage across the sense element is generally small and is often riding on a common-mode voltage that is considerably larger than the differential voltage itself. Accurate amplification of the differential voltage requires a differential amplifier with high input impedance, high CMR (common-mode rejection); wide input-common-mode voltage range; and high, well-defined gain. Traditional instrumentation ampli-

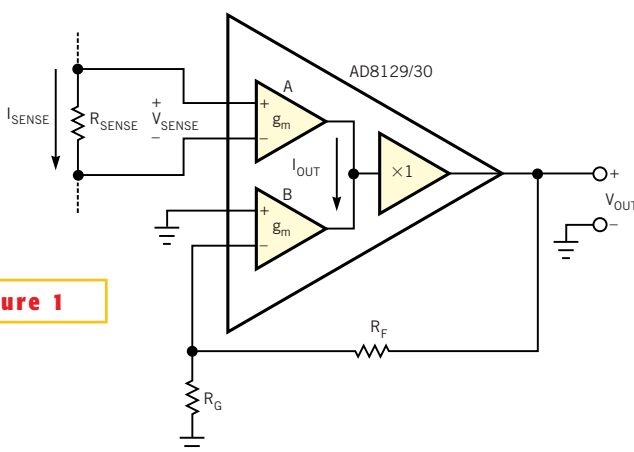

**Figure 1**

An active-feedback amplifier is ideal for current-sensing applications.

fiers have these features and often serve for low-frequency current sensing, but they perform poorly at high speeds. High-speed current sensing requires the kind of performance that instrumentation amps provide, but their abilities

must extend to high frequencies. **Figure 1** shows how high-speed active feedback amplifiers, such as the AD8129 and AD8130 differential receivers, are ideal for these high-speed instrumentation-amp applications. The AD8129 requires a minimum closed-loop voltage gain of 10 for stability, whereas the AD8130 is unity-gain-stable.

Active-feedback amplifier operation differs from that of traditional op amps; it provides a

beneficial separation between the signal input and the feedback network. **Figure 1** shows a high-level block diagram of an active-feedback amplifier in a typical closed-loop configuration. High-speed current sensing uses a resistor as the sense element. The input stages are high-impedance, high-CMR, wideband, high-gain transconductance amplifiers with closely matched transconductance parameters. The output currents of the transconductance amplifiers undergo summing, and the voltage at the summing node is buffered to provide a low-impedance output. Applying negative feedback around amplifier B drives  $V_{OUT}$  to a level that forces the input voltage of amplifier B to equal the negative value of the input voltage at amplifier A, because the current from amplifier A equals the negative value of the current from amplifier B, and the gm values are closely matched. From the foregoing discussion, you can express the closed-loop voltage gain for the ideal case as:  $V_{OUT}/V_{IN} = 1 + R_F/R_G \equiv A_V$ .

Measurement sensitivity in volts per amp is expressed as:  $V_{OUT}/I_{SENSE} = A_V R_{SENSE}$ . Minimizing the values of  $R_F$  and  $R_G$  also minimizes resistor and output-voltage noise arising from input-referred current

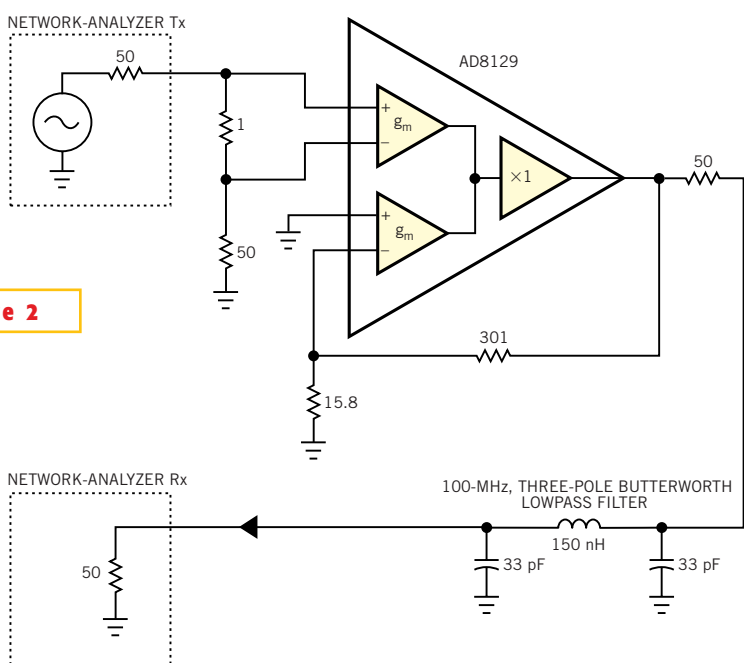
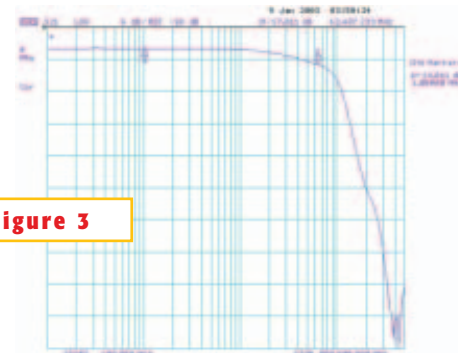

**Figure 2**

This test circuit produces flat frequency response to 10 MHz.

noise. Because of the small sense resistance and high measurement frequencies, you must minimize parasitic effects in the input circuitry to avoid measurement errors. Parasitic trace inductance in series with the sense element is of particular concern, because it causes the impedance across the amplifier's input to increase with increasing frequency, producing a spurious increase in output voltage at high frequencies. **Figure 2** illustrates a test circuit with  $R_{\text{SENSE}}=1\Omega$  and  $A_v=20$ , which equates to a measurement sensitivity of  $20V/A$ . The three-pole lowpass filter produces a defined bandwidth and

attenuates spurious responses at the amplifier's output arising from input signals at frequencies outside the desired measurement bandwidth. The test circuit's frequency response in **Figure 3** shows that the expected differential-to-single-ended gain of  $20/101$ , or  $-14\text{ dB}$ , is flat to approximately  $10\text{ MHz}$  and is down by  $3\text{ dB}$  at  $62\text{ MHz}$ . **Figure 3** demonstrates the effectiveness of the high CMR of active-feedback amplifiers. The common-mode signal at the amplifier's input is approximately 50 times greater than the differential signal across the sense resistor. □



**Figure 3**

The test circuit in **Figure 2** exhibits accurate differential gain in the presence of large common-mode signals.

## Create secondary colors from multicolored LEDs

Claude Haridge, Stittsville, ON, Canada

IT IS WELL-KNOWN that simultaneously mixing two primary-color light sources, such as red and green, creates a secondary color, such as yellow. This mixing process commonly occurs in tricolor LEDs. One disadvantage of this method of generating a yellow color is that the LED must use twice the current because both the red and the green LEDs must be on. In battery-powered circuits, the LED indicator's operating current may be a significant fraction of the supply current, so using the same current to generate both primary and secondary colors is advantageous. The operating-current savings may be significant in telecom-line-card applications involving thousands of line cards or large-panel RGB LED displays. This Design Idea proposes a sequencing method to generate balanced secondary colors from bicolor, tricolor, and RGB LEDs, using only one LED's operating current. Advantages include lower power dissipation and more uniform intensities between primary and secondary colors. Using the sequencing method also allows a bicolor LED to now produce three colors and keep a simpler pc-board layout using two rather than three pins. In addition, you can also produce white light with RGB LEDs using the sequencing method.

The method uses the property of images to persist in the human eye for several tens of milliseconds. If different pri-

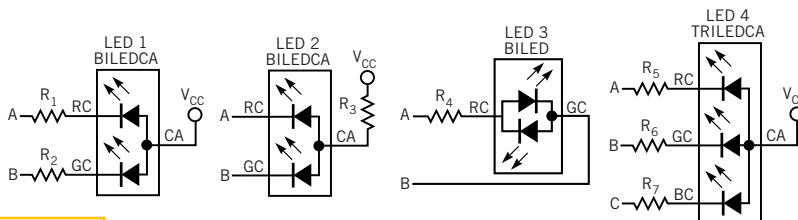

**Figure 1**

NOTES:  
CA=COMMON ANODE.  
CC=COMMON CATHODE.

All these LED configurations can produce secondary colors, either by current control or duty-cycle control.

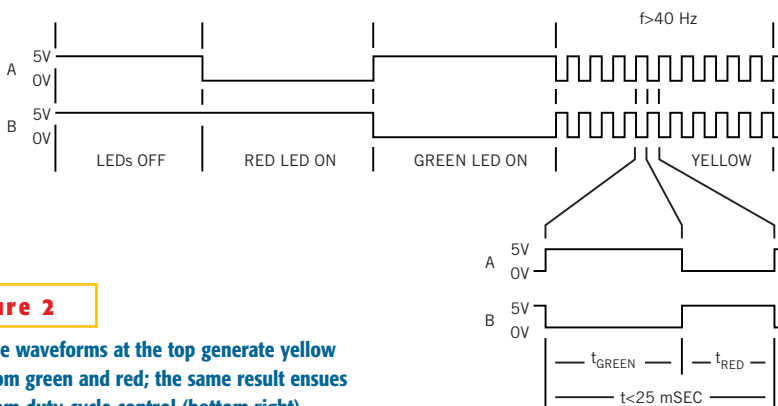

**Figure 2**

The waveforms at the top generate yellow from green and red; the same result ensues from duty-cycle control (bottom right).

mary colors flash sequentially and quickly enough from one point, humans see them as overlapping in time, and the brain interprets them to appear as secondary colors or even white, depending on the color components. Experimentation with two or three primary-color LEDs shows that the flash sequence must

complete within approximately 25 msec or less to produce a solid secondary color or white light. In testing for an upper limit, you can use flash rates to 1 MHz to produce this effect without degrading secondary colors. Thus, you can use any convenient clock source higher than 40 Hz to create secondary colors. Note that

the primary-color LEDs must be physically close together, such as on a semiconductor chip, for the eye to properly mix the light. Diffused lenses also allow a wider viewing angle. These combinations are commercially available as bicolor, tricolor, and RGB LEDs.

Figure 1 shows the various LED-circuit configurations, and Figure 2 shows the timing to generate all three colors from bicolor and tricolor LEDs, although using only one LED's operating current. Note that the driver for the bicolor LED must be able to sink and source current. You may have to provide color balance between the primary-color LEDs to ensure that the secondary colors appear properly. The LEDs have different efficiencies and intensities as the human eye sees them, and these parameters need correcting. For tricolor LEDs in a com-

mon-anode or -cathode configuration and 50% duty cycle, the correction is easy to effect by adjusting the current-limiting resistors. Alternatively, you can use one current-limiting resistor and

both bicolor and tricolor LEDs.

Using a sequenced bicolor LED to generate three colors has packaging advantages, particularly when you vertically stack several LEDs. Previously, stacked, tricolor LEDs needed to use a through-hole assembly, because the middle lead would be inaccessible if the devices were surface-mounted. Because the bicolor LED has only two pins, you can vertically stack several of them and bend out the leads for surface mounting. The generation

of secondary colors can also extend to RGB LEDs (Table 1). You can achieve color balancing by adjusting the current-limiting resistors or the duty cycle. You can program three pins from a microcontroller's port to sequence through the various primary-color combinations. □

**TABLE 1—SECONDARY COLORS FROM RGB LEDs**

Red	Green	Blue	Emitted color	Notes
0	0	0	None	
1	0	0	Red	
0	1	0	Green	
0	0	1	Blue	
1	1	0	Yellow	Red/green sequenced
0	1	1	Cyan	Green/blue sequenced
1	0	1	Magenta	Blue/red sequenced
1	1	1	White	Red/green/blue sequenced

then vary the duty cycle to provide the necessary color balance. For two-leaded, bicolor LEDs, it is easier to adjust the duty cycle to produce the correct secondary color than to use additional circuitry. The waveforms at the bottom of Figure 2 illustrate duty-cycle control to achieve secondary-color balance for