

Applications of the LM392 Comparator Op Amp IC

National Semiconductor
Application Note 286
September 1981



The LM339 quad comparator and the LM324 op amp are among the most widely used linear ICs today. The combination of low cost, single or dual supply operation and ease of use has contributed to the wide range of applications for these devices.

The LM392, a dual which contains a 324-type op amp and a 339-type comparator, is also available. This device shares all the operating features and economy of 339 and 324 types with the flexibility of both device types in a single 8-pin mini-DIP. This allows applications that are not readily implemented with other devices but retain simplicity and low cost. *Figure 2* provides an example.

Sample-Hold Circuit

The circuit of *Figure 2* is an unusual implementation of the sample-and-hold function. Although its input-to-output relationship is similar to standard configurations, its operating principle is different. Key advantages include simplicity, no hold step, essentially zero gain error and operation from a single 5V supply. In this circuit the sample-and-hold command pulse (Trace A, *Figure 1*) is applied to Q3, which turns on, causing current source transistor Q4's collector (Trace B, *Figure 1*) to go to ground potential. Amplifier A1 follows Q4's collector voltage and provides the circuit's output (Trace C, *Figure 1*). When the sample-and-hold command pulse falls, Q4's collector drives a constant current into the 0.01 μF capacitor. When the capacitor ramp voltage equals the circuit's input voltage, comparator C1 switches, causing Q2 to turn off the current

source. At this point the collector voltage of Q4 sits at the circuit's input voltage. Q1 insures that the comparator will not self trigger if the input voltage increases during a "hold" interval. When a DC biased sine wave is applied to the circuit (Trace D, *Figure 1*) the sampled output (Trace E, *Figure 1*) is available at the circuit's output. The ramping action of the Q4 current source during the "sample" states is just visible in the output.

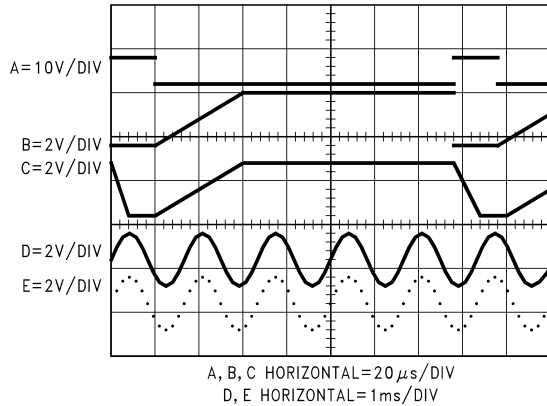
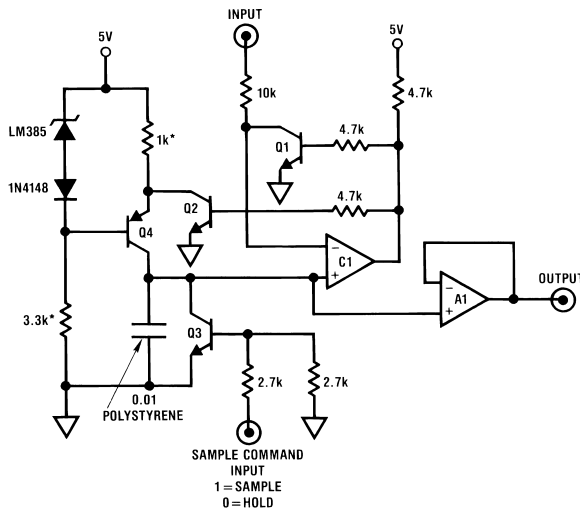

FIGURE 1.

00749301



00749302

Q1, Q2, Q3 = 2N2369
Q4 = 2N2907
C1, A1 = LM392 amplifier-comparator dual
*1% metal film resistor

FIGURE 2.

“Fed-Forward” Low-Pass Filter

In *Figure 3* the LM392 implements a useful solution to a common filtering problem. This single supply circuit allows a signal to be rapidly acquired to final value but provides a long filtering constant. This characteristic is useful in multiplexed data acquisition systems and has been employed in electronic infant scales where fast, stable readings of infant weight are desired despite motion on the scale platform. When an input step (Trace A, *Figure 4*) is applied, C1's negative input will immediately rise to a voltage determined by the 1k pot-10 kΩ divider. C1's "+" input is biased through the 100 kΩ-0.01 μF time constant and phase lags the input. Under these conditions C1's output will go low, turning on

Q1. This causes the capacitor (Waveform B, *Figure 1*) to charge rapidly towards the input value. When the voltage across the capacitor equals the voltage at C1's positive input, C1's output will go high, turning off Q1. Now, the capacitor can only charge through the 100k value and the time constant will be long. Waveform B clearly shows this. The point at which the filter switches from short to long time constant is adjustable with the 1 kΩ potentiometer. Normally, this is adjusted so that switching occurs at 90%–98% of final value, but the photo was taken at a 70% trip point so circuit operation is easily discernible. A1 provides a buffered output. When the input returns to zero the 1N933 diode, a low forward drop type, provides rapid discharge for the capacitor.

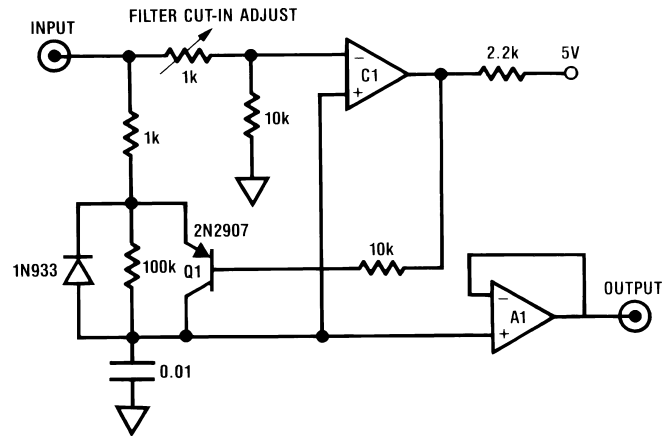

A1, C1 = LM392 amplifier-comparator dual

00749303

FIGURE 3.

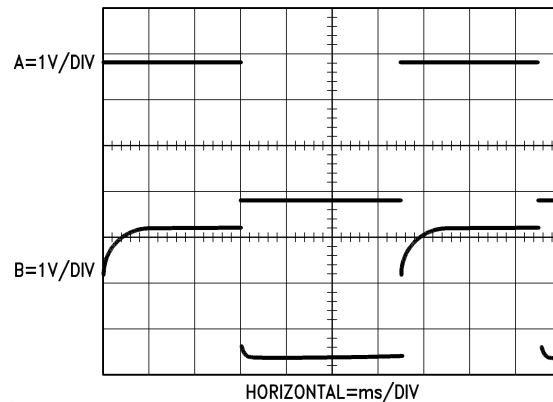

00749304

FIGURE 4.

Variable Ratio Digital Divider

In *Figure 5* the circuit allows a digital pulse input to be divided by any number from 1 to 100 with control provided by a single knob. This function is ideal for bench type work where the rapid set-up and flexibility of the division ratio is highly desirable. When the circuit input is low, Q1 and Q3 are off and Q2 is on. This causes the 100 pF capacitor to accumulate a quantity of charge (Q) equal to

$$Q = CV$$

where $C = 100 \text{ pF}$

and $V =$ the LM385 potential (1.2V) minus the $V_{CE(SAT)}$ of Q2.

When the input goes high (Trace A, *Figure 6*) Q2 goes off and Q1 turns on. This causes Q3 to displace the 100 pF capacitor's charge into A1's summing junction. A1's output responds (Waveform B, *Figure 6*) by jumping to the required

Variable Ratio Digital Divider

(Continued)

value to maintain the summing junction at 0V. This sequence is repeated for every input pulse. During this time A1's output will form the staircase shape shown in Trace B as the 0.02 μ F feedback capacitor is pumped up by the charge dispensing action into A1's summing junction. When A1's output is great enough to just bias C1's "+" input below

ground, C1's output (Trace C, Figure 6) goes low and resets A1 to 0V. Positive feedback through the 300 pF unit, insuring adequate reset time for A1. The 1 M Ω potentiometer, by setting the number of steps in the ramp required to trip C1, controls the circuit input-output division ratio. Traces E–G expand the scale to show circuit detail. When the input (Trace E) goes high, charge is deposited into A1's summing junction (Trace F) and the resultant staircase waveform (Trace G) takes a step.

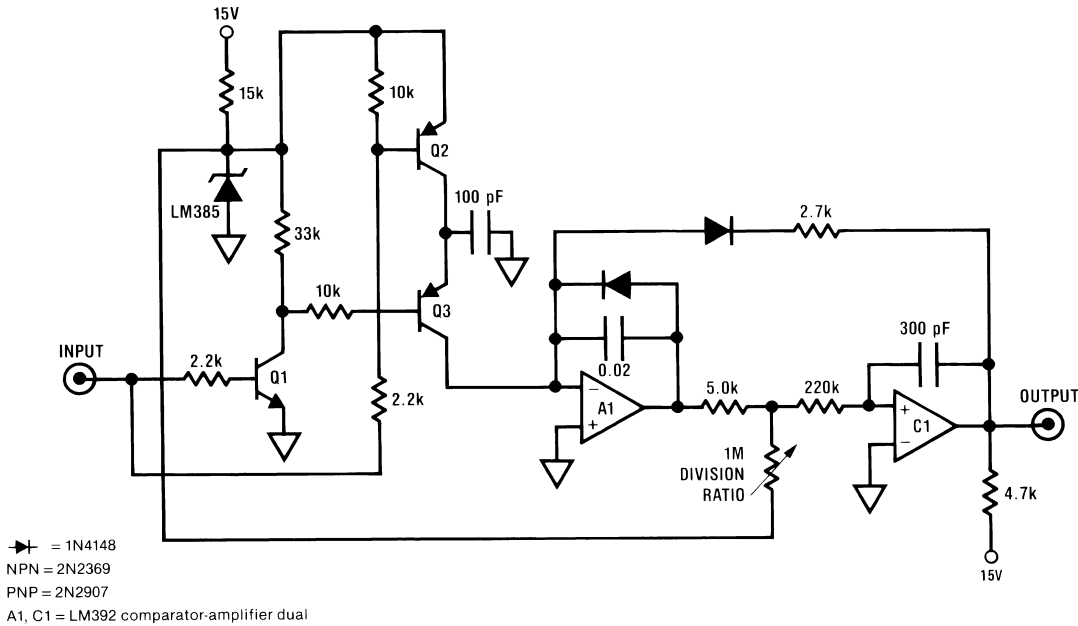

00749305

FIGURE 5.

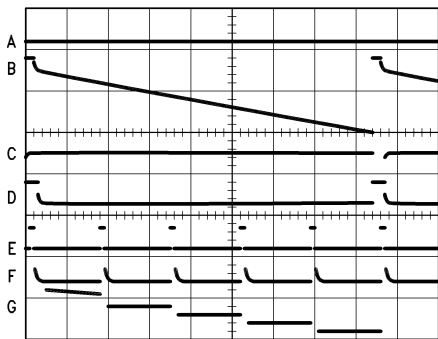

00749306

FIGURE 6.

Trace	Vertical	Horizontal
A	10V	500 μ s
B	1V	500 μ s
C	50V	500 μ s
D	50V	500 μ s
E	10V	50 μ s

Trace	Vertical	Horizontal
F	10 mA	50 μ s
G	0.1V	50 μ s

Exponential V/F Converter for Electronic Music

Professional grade electronic music synthesizers require voltage controlled frequency generators whose output frequencies are exponentially related to the input voltages. Figure 7 diagrams a circuit which performs this function with 0.25% exponential conformity over a range from 20 Hz to 15 kHz using a single LM392 and an LM3045 transistor array. The exponential function is generated by Q1, whose collector current will vary exponentially with its base-emitter voltage in accordance with the well known relationship between BE voltage and collector current in bipolar transistors. Normally, this transistor's operating point will vary wildly with temperature and elaborate and expensive compensation is required. Here, Q1 is part of an LM3045 transistor array. Q2 and Q3, located in the array, serve as a heater-sensor pair for A1, which servo controls the temperature of Q2. This causes the entire LM3045 array to be at constant temperature, eliminating thermal drift problems in Q1's operation. Q4 acts as a clamp, preventing servo lock-up during circuit start-up.

Exponential V/F Converter for Electronic Music (Continued)

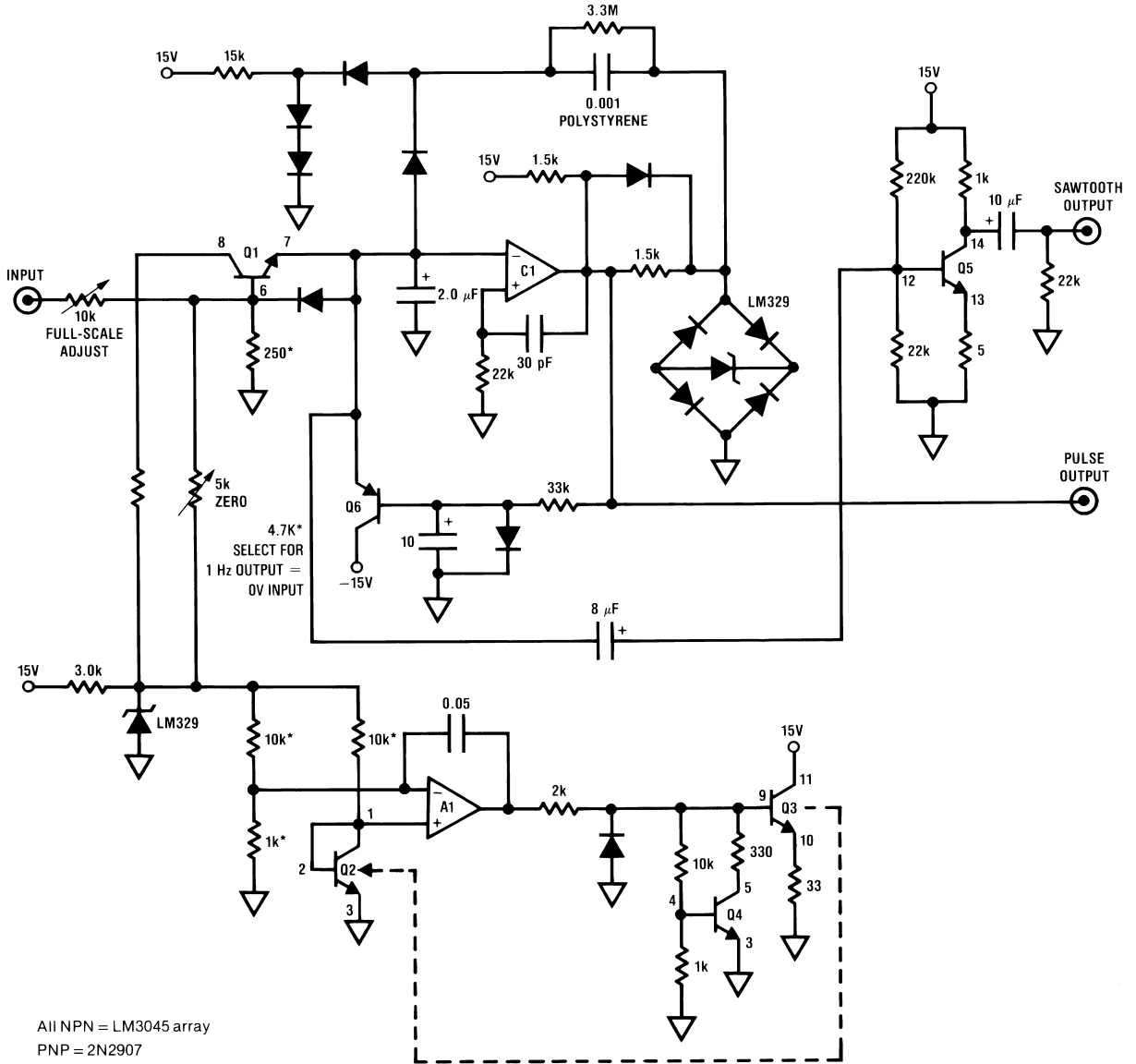

All NPN = LM3045 array
 PNP = 2N2907
 * = 1% film resistor
 A1, C1 = LM392 amplifier-comparator dual
 —▶ = 1N4148

00749307

FIGURE 7.

Q1's current output is fed into the summing junction of a charge dispensing I/F converter. C1's output state is used to switch the 0.001 µF capacitor between a reference voltage and C1's "−" input. The reference voltage is furnished by the LM329 zener diode bridge. The comparator's output pulse width is unimportant as long as it permits complete charging and discharging of the capacitor. In operation, C1 drives the 30 pF-22k combination. This RC provides regenerative feedback which reinforces the direction of C1's output. When the 30 pF-22k combination decays, the positive feedback ceases. Thus, any negative going amplifier output will be followed by a positive edge after an amount of time governed by the 30 pF-22k time constant (Waveforms A and B, Figure 8). The actual integration capacitor in the circuit is the 2 µF

electrolytic. This capacitor is never allowed to charge beyond 10 mV–15 mV because it is constantly being reset by charge dispensed from the switching of the 0.001 µF capacitor (Waveform C, Figure 8). Whenever the amplifier's output goes negative, the 0.001 µF capacitor dumps a quantity of charge (Waveform D) into the 2 µF capacitor, forcing it to a lower potential. The amplifier's output going negative also causes a short pulse to be transferred through the 30 pF capacitor to the "+" input. When this negative pulse decays out so that the "+" input is higher than the "−" input, the 0.001 µF capacitor is again able to receive a charge and the entire process repeats. The rate at which this sequence occurs is directly related to the current into C1's summing junction from Q1. Since this current is exponentially related to the

Exponential V/F Converter for Electronic Music (Continued)

circuit's input voltage, the overall I/F transfer function is exponentially related to the input voltage. This circuit can lock-up under several conditions. Any condition which would allow the $2\ \mu\text{F}$ electrolytic to charge beyond $10\ \text{mV}$ – $20\ \text{mV}$ (start-up, overdrive at the input, etc.) will cause the output of the amplifier to go to the negative rail and stay there. The 2N2907A transistor prevents this by pulling the “–” input

towards -15V . The $10\ \mu\text{F}$ - 33k combination determines when the transistor will come on. When the circuit is running normally, the 2N2907 is biased off and is effectively out of the circuit. To calibrate the circuit, ground the input and adjust the zero potentiometer until oscillations just start. Next, adjust the full-scale potentiometer so that frequency output exactly doubles for each volt of input (e.g., 1V per octave for musical purposes). Repeat these adjustments until both are fixed. C1 provides a pulse output while Q5 AC amplifies the summing junction ramp for a sawtooth output.

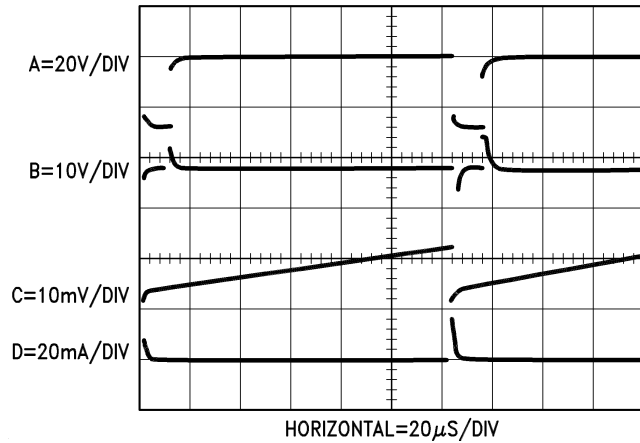

00749308

FIGURE 8.

Linearized Platinum RTD Thermometer

In *Figure 9* the LM392 is used to provide gain and linearization for a platinum RTD in a single supply thermometer circuit which measures from 0°C to 500°C with $\pm 1^{\circ}\text{C}$ accuracy. Q1 functions as a current source which is slaved to the LM103-3.9 reference. The constant current driven platinum sensor yields a voltage drop which is proportionate to temperature. A1 amplifies this signal and provides the circuit output. Normally the slight nonlinear response of the RTD would limit accuracy to about ± 3 degrees. C1 compensates for this error by generating a breakpoint change in A1's gain

for sensor outputs above 250°C . When the sensor's output indicates 250°C , C1's “+” input exceeds the potential at the “–” input and C1's output goes high. This turns on Q2 whose collector resistor shunts A1's 6.19k feedback value, causing a gain change which compensates for the sensor's slight loss of gain from 250°C to 500°C . Current through the 220k resistor shifts the offset of A1 so no “hop” occurs at the circuit output when the breakpoint is activated. A precision decade box is used to calibrate this circuit. With the box inserted in place of the sensor, adjust 0°C for 0.10V output for a value of 1000Ω . Next dial in 2846Ω (500°C) and adjust the gain trim for an output of 2.60V . Repeat these adjustments until both zero and full-scale are fixed at these points.

Linearized Platinum RTD Thermometer (Continued)

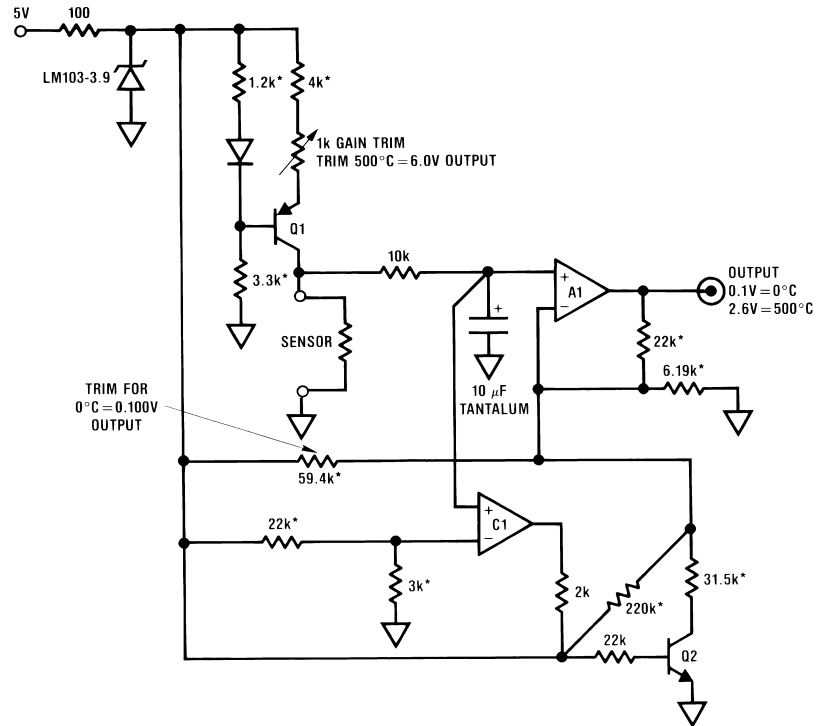

00749309

Sensor = Rosemount
118 MF-1000-A
1000Ω at 0°C

Q1 = 2N2907

Q2 = 2N2222A

A1, C1 = LM392 amplifier-comparator dual

*metal film resistor

FIGURE 9.

Temperature Controller

Figure 10 details the LM392 in a circuit which will temperature-control an oven at 75°C. This is ideal for most types of quartz crystals. 5V single supply operation allows the circuit to be powered directly from TTL-type rails. A1, operating at a gain of 100, determines the voltage difference between the temperature setpoint and the LM335 temperature sensor, which is located inside the oven. The temperature setpoint is established by the LM103-3.9 reference and

the 1k–6.8k divider. A1's output biases C1, which functions as a pulse width modulator and biases Q1 to deliver switched-mode power to the heater. When power is applied, A1's output goes high, causing C1's output to saturate low. Q1 comes on and delivers DC to the heater. When the oven warms to the setpoint, A1's output falls and C1 begins to pulse width modulate the heater in servo control fashion. In practice the LM335 should be in good thermal contact with the heater to prevent servo oscillation.

Temperature Controller (Continued)

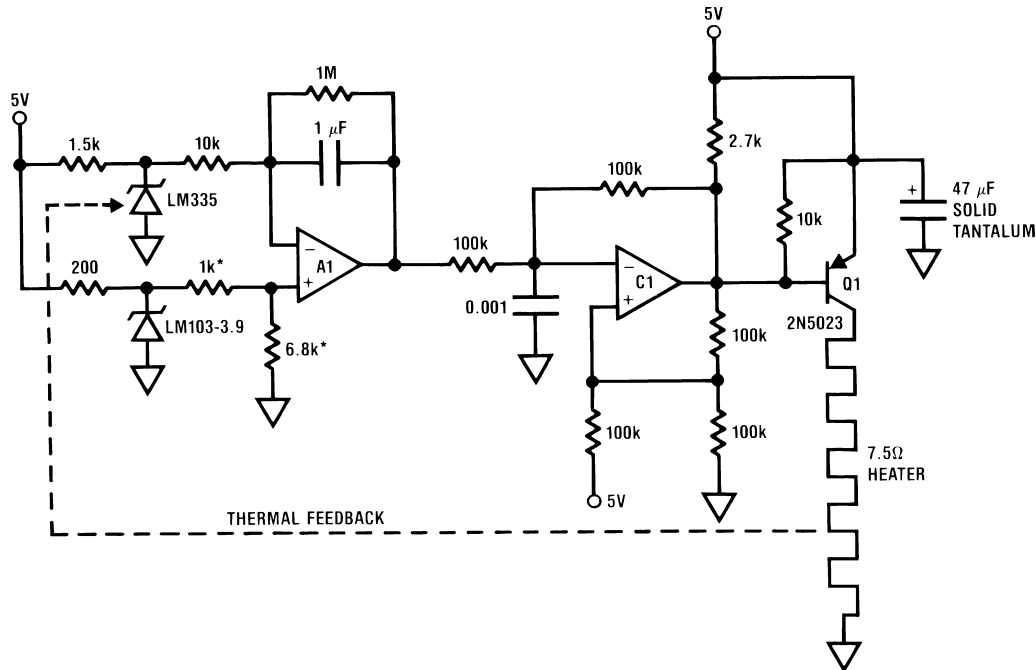

A1, C1 = LM392 amplifier-comparator dual

00749310

FIGURE 10.

References

1. *Transducer Interface Handbook*, pp. 220–223; Analog Devices, Inc.
2. "A New Ultra-Linear Voltage-to-Frequency Converter", Pease, R. A.; 1973 *NEREM Record* Volume 1, page 167.

LIFE SUPPORT POLICY

NATIONAL'S PRODUCTS ARE NOT AUTHORIZED FOR USE AS CRITICAL COMPONENTS IN LIFE SUPPORT DEVICES OR SYSTEMS WITHOUT THE EXPRESS WRITTEN APPROVAL OF THE PRESIDENT AND GENERAL COUNSEL OF NATIONAL SEMICONDUCTOR CORPORATION. As used herein:

1. Life support devices or systems are devices or systems which, (a) are intended for surgical implant into the body, or (b) support or sustain life, and whose failure to perform when properly used in accordance with instructions for use provided in the labeling, can be reasonably expected to result in a significant injury to the user.
2. A critical component is any component of a life support device or system whose failure to perform can be reasonably expected to cause the failure of the life support device or system, or to affect its safety or effectiveness.



National Semiconductor Corporation
Americas
Email: support@nsc.com

www.national.com

National Semiconductor Europe

Fax: +49 (0) 180-530 85 86
Email: europe.support@nsc.com
Deutsch Tel: +49 (0) 69 9508 6208
English Tel: +44 (0) 870 24 0 2171
Français Tel: +33 (0) 1 41 91 8790

National Semiconductor Asia Pacific Customer Response Group

Tel: 65-2544466
Fax: 65-2504466
Email: ap.support@nsc.com

National Semiconductor Japan Ltd.

Tel: 81-3-5639-7560
Fax: 81-3-5639-7507