



## Electrically operated expansion valves, type ETS 25 and 12½



**Contents**

	<b>Page</b>
Introduction.....	4
Features.....	4
Technical data.....	4
Electrical data.....	5
Design.....	5
Valve operation.....	6-7
Sizing.....	7
Ordering:	
Valve incl. actuator.....	8
Accessories.....	8
Capacities:	
SI units.....	9
US units.....	10
Dimensions and weight.....	11

**Introduction**

ETS 25 also including a size 12½ is supplementing the ETS series of electrically operated expansion valves for precise liquid injection in evaporators for air conditioning and refrigeration applications.

The valve design is providing a bi-flow feature as well as solenoid tight shut-off function in both flow directions.

The ETS needs a current or voltage driver as partner to be operated.

EKC316A, 312 and EKD316 are examples of Danfoss controllers with drivers matching the ETS needs.

The ETS design is being registered. The pending reference number is 200530003728.1.



**Features**

- Precise positioning for optimal control of liquid injection.
- ETS 25 and 12½ are designed for HFC/HCFC conditions including R410A, providing 45.5 bar (659.9 psig) working pressure.
- Design providing bi-flow operation as well as solenoid tight shut-off function in both flow directions at MOPD 33 bar (478.6 psig).
- ETS 25 and 12½ are available with straight as well as angle ODF solder connections.
- ETS 25 and 12½ are equipped with AST-g MKII actuator with M12 connector for cable connection.
- Cable and connector assemblies as accessories.
- For manual operation and service of ETS valves an AST-g service driver is available. For further information please contact Danfoss (Commercial Refrigeration & Air Conditioning Controls).

**Technical data**

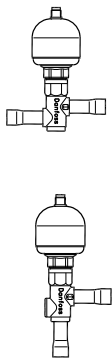

Parameter	ETS 25 / ETS 12½
Compatibility	HFC, HCFC
CE marking	No
MOPD	33 bar (478.6 psi)
Max. working pressure (PS/MWP)	45.5 bar (659.9 psi)
Refrigerant temperature range	-40°C to 10°C (-40°F to 50°F)
Ambient temperature	-40°C to 60°C (-40°F to 140°F)
Total stroke	13 mm (0.5 in.)
M12 connection	IP 67

Electrical data

Parameter	ETS 25, 12½
Stepper motor type	Bi-polar - permanent magnet
Step mode	2 phase full step
Phase resistance	52Ω ±10%
Phase inductance	85 mH
Holding current	Depends on application. Full current allowed (100% duty cycle)
Step angle	7.5° (motor), 0.9° (lead screw), Gearing ratio 8.5:1. (38/13) <sup>2</sup> :1
Nominal voltage	(Constant voltage drive) 12 V dc -4% +15%
Phase current	(Using chopper drive) 100 mA RMS -4% +15%,
Max. total power	Voltage / current drive: 5.5 / 1.3 W (UL: NEC class 2)
Step rate	150 steps/sec. (constant voltage drive) 0-300 steps/sec. 300 recommended (chopper current drive)
Total steps	ETS 25, 12½: 2625 [+160 / -0] steps
Full travel time	ETS 25, 12½: 17 / 8.5 sec. (voltage / current)
Lifting height	ETS 25, 12½: 13 mm (0.5 in.)
Reference position	Overdriving against the full close position
Electrical connection	M12 connector

Stepper motor switch sequence:



	STEP	Coil I		Coil II		
		Red	Green	White	Black	
↑ CLOSING ↑	1	+	-	+	-	↓ OPENING ↓
	2	+	-	-	+	
	3	-	+	-	+	
	4	-	+	+	-	
	1	+	-	+	-	

Design

Valve / Actuator type ETS / AST-g

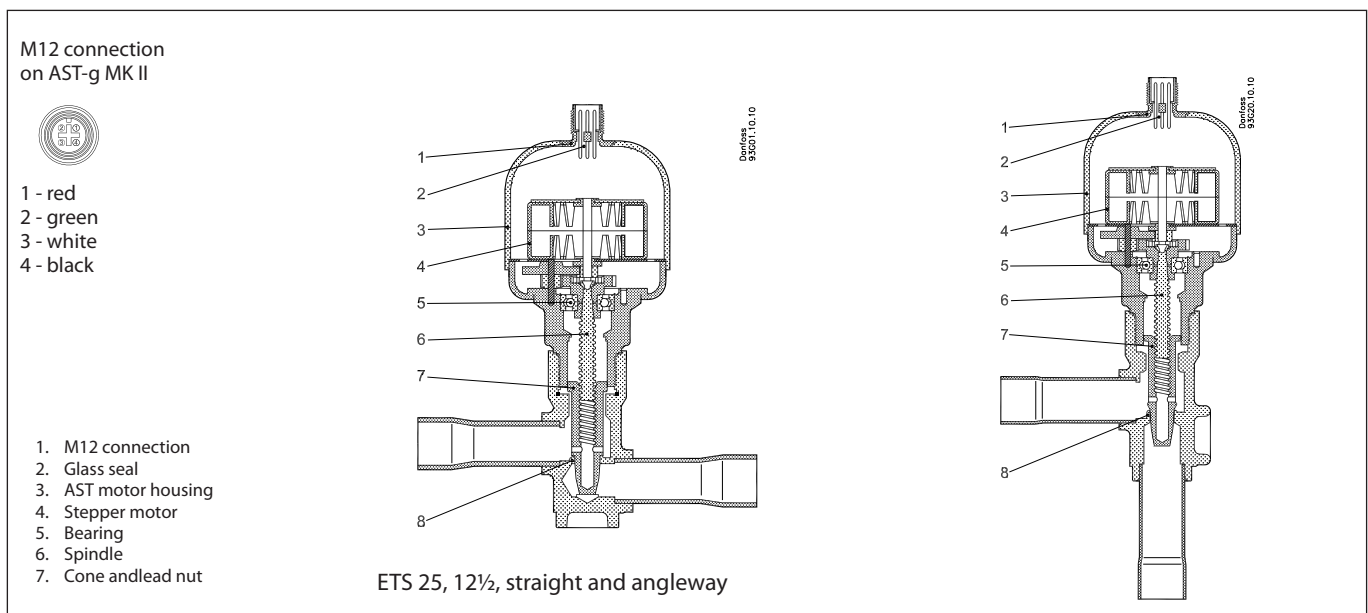

Valve operation

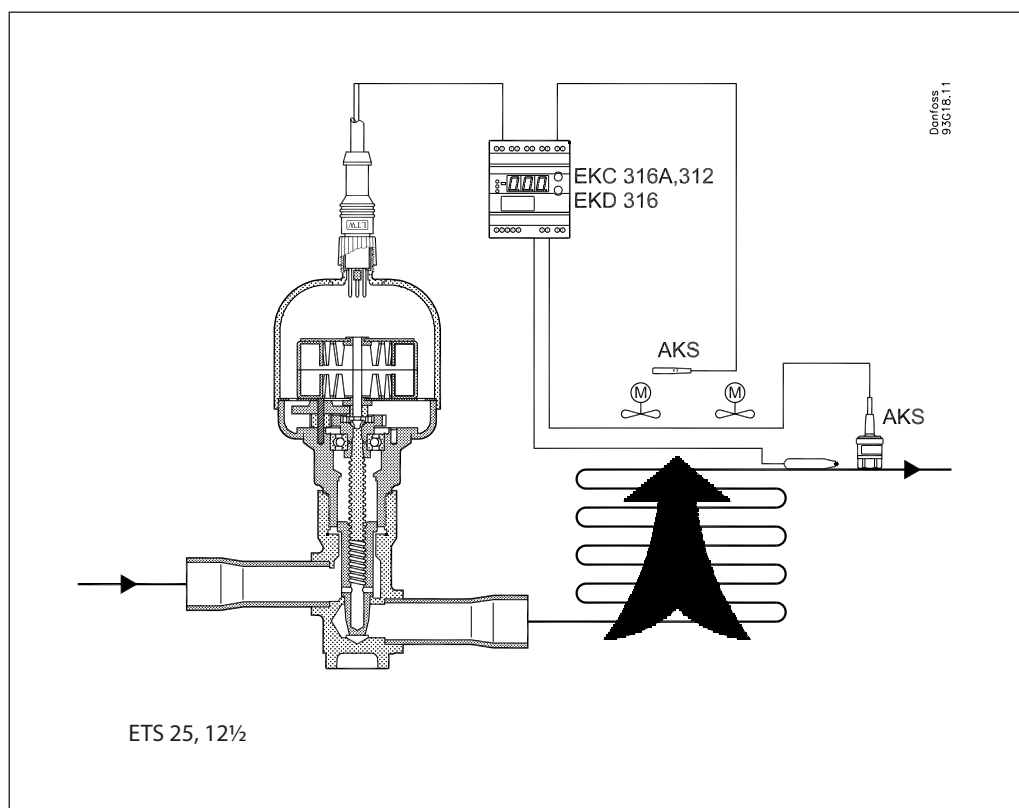

The ETS valves operate modulating by electronically controlled activation of the AST stepper motor. The motor is a type 2-phase bi-polar, which stays in position, unless power pulses from a driver initiate the two discrete sets of motor stator windings for rotation in either directions.

The direction depends on the phase relationship of the power pulses, which number again is decisive for the travel.

The motor is operating the spindle, which rotating movements are transformed into linear motion by the transmission in the cage cone assembly.

The AST motor housing has a glass sealed M12 connection as standard, which can be connected with customized cable and plug/socket combinations.

The cone and orifice design is giving identical bi-flow performance capabilities and nearby identical maximum capacities.

The port design includes a shut-off function with "solenoid" tightness in both flow directions. Closed position is also the mechanical stop acting as reference point to reset the controller. By overdriving

permanently while closed induces that the reference number in steps always is correct.

Operating the ETS series requires a controller with either 12V dc voltage drive (5.5W) or using chopper drive (100 mA RMS).

Danfoss EKC316A, 312 and EED316 are examples of qualified controllers.

**Note:**

Depending on the type of controller or rather driver, there will be limitations in cable length between valve actuator and driver.

Both the actual cable length, the level of EMC emission on the location and driver circuit has an impact on the actual distortion of the current to the actuator motor.

For the Danfoss controllers the rule of thumb is maximum 5 m [15 feet] for EKC316 and 312 and 50 m [150 feet] for EKD316.

In all these controllers a 10 mH filter type AKA 211 can be installed on the four power terminals that can increase the maximum cable length considerably. Please contact Danfoss for further information how and when to apply this countermeasure in cases with questionable cable length.

Valve operation (Cont.)

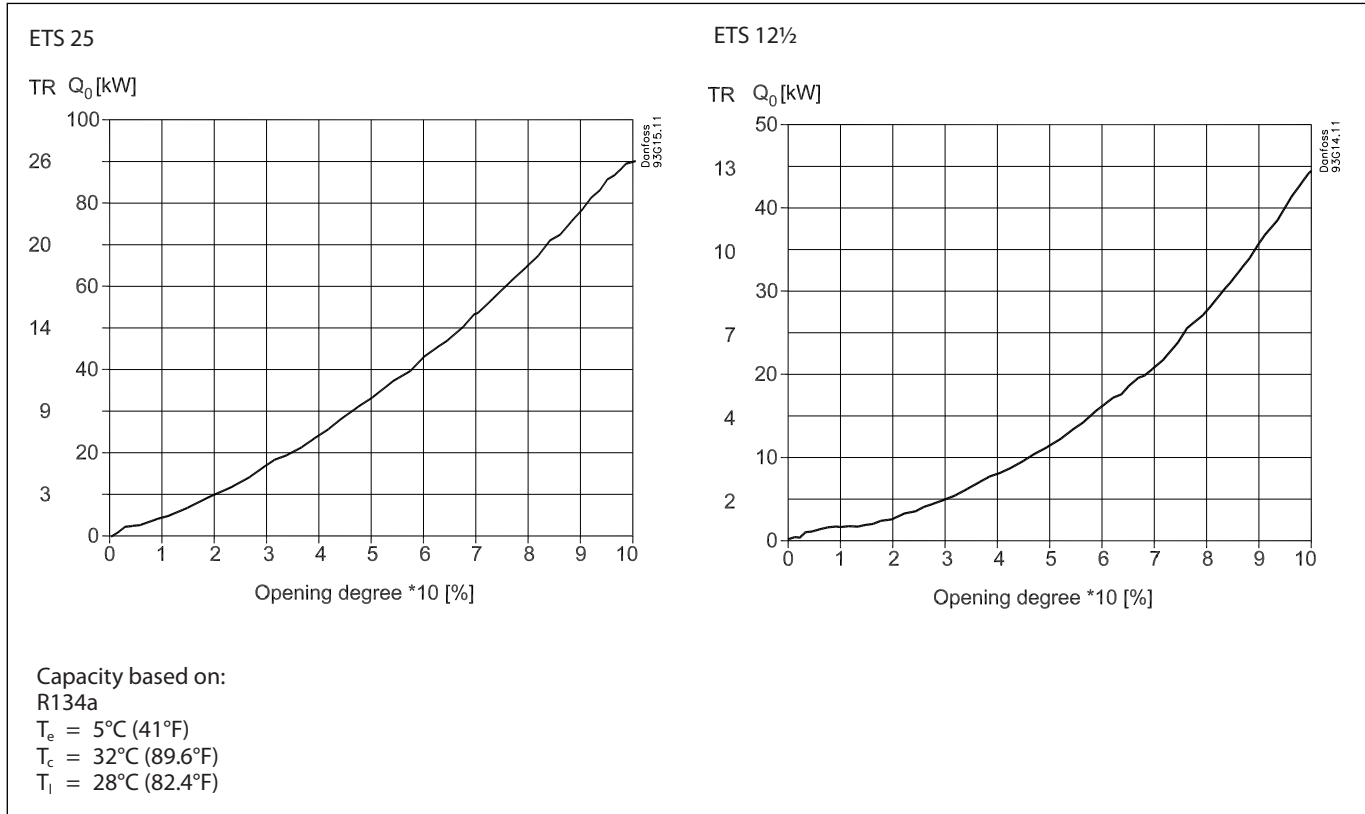

Sizing

**Correction for subcooling  $\Delta t_{sub}$**   
The evaporator capacity used must be corrected if subcooling deviates from 4K (7.2°F). The corrected capacity can be obtained by dividing the evaporator capacity by the correction factor given below.

**Note:**  
Insufficient subcooling can produce flash gas.

Correction factor	$\Delta t_{sub}$									
	4 K	10 K	15 K	20 K	25 K	30 K	35 K	40 K	45 K	50 K
	7.2°F	18°F	27°F	36°F	45°F	54°F	63°F	72°F	81°F	90°F
R22	1.00	1.06	1.11	1.15	1.20	1.25	1.30	1.35	1.39	1.44
R410A	1.00	1.08	1.15	1.21	1.27	1.33	1.39	1.45	1.50	1.56
R407C	1.00	1.08	1.14	1.21	1.27	1.33	1.39	1.45	1.51	1.57
R134a	1.00	1.08	1.13	1.19	1.25	1.31	1.37	1.42	1.48	1.54
R404A / R507	1.00	1.10	1.20	1.29	1.37	1.46	1.54	1.63	1.70	1.78

**Example:**

Refrigerant: R410A  
Evaporating temperature:  
 $t_e = +10^\circ\text{C}$  (50°F)  
 $p_e = 9.8$  bar (142 psig)  
Condensing temperature:  
 $t_c = 40^\circ\text{C}$  (104°F)  
 $p_c = 23$  bar (330 psig)  
Pressure drop in valve:  
 $\Delta p = 23 - 9.8 = 13.2$  bar (192 psig)  
Subcooling:  $\Delta t_{sub} = 15$  K (27°F)  
Evaporator capacity: 50 kW (14,3 TR)  
Correction value from table: 1.15

The corrected evaporator capacity thus becomes  
 $50 : 1.15 = 43.5$  kW (12.4 TR)

As the ETS series has a wide capacity area from the table values down to 10% of these, the sizing is not critical.

Under the given circumstances ETS 12½ can operate between 82 kW (142 TR?) and 8 kW (2.3 TR).

Bi-flow capacities (opposite of normal flow direction) are the same for ETS 25, 12½.

**Ordering**

**Valve incl. actuator**

Single pack

Type	Rated capacity <sup>1)</sup>										Connection			
	R410A		R407C		R22		R134a		R404A		ODF × ODF [in]	ODF × ODF [mm]	Code no. Straight way	Code no. Angle way
	kW	TR	kW	TR	kW	TR	kW	TR	kW	TR				
ETS 12½	70	20	63	18	57	16	45	13	43	12	½ × ½		<b>034G4009</b>	<b>034G4013</b>
												12 × 12	<b>034G4008</b>	<b>034G4012</b>
											5/8 × 5/8	16 × 16	<b>034G4010</b>	<b>034G4014</b>
											7/8 × 7/8	22 × 22	<b>034G4011</b>	<b>034G4015</b>
ETS 25	144	41	129	37	117	34	93	27	88	25	½ × ½		<b>034G4001</b>	<b>034G4005</b>
												12 × 12	<b>034G4000</b>	<b>034G4004</b>
											5/8 × 5/8	16 × 16	<b>034G4002</b>	<b>034G4006</b>
											7/8 × 7/8	22 × 22	<b>034G4003</b>	<b>034G4007</b>

1) The Rated capacity is based on:  
 Evaporating temperature t<sub>e</sub>: 5°C (40°F)  
 Liquid temperature t<sub>l</sub>: 28°C (82°F)  
 Condensing temperature t<sub>c</sub>: 32°C (90°F)  
 Full stroke opening.

**Accessories**

M12 connector on cable



- 1 - red
- 2 - green
- 3 - white
- 4 - black

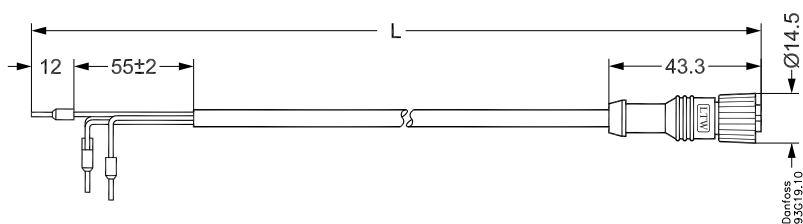

Cable and connector assemblies for ETS with AST-g MK II actuator

Cable quality	Temperature range	Cable length	Design	Code no
Jacket: PVC Insulation: PVC	-50 / +80°C	2 m	M12, 4 pins to actuator and loose wires for driver connection	<b>034G2330</b>
		8 m		<b>034G2323</b>
Jacket: CPE Insulation: EPR	-40 / +80°C	2 m		<b>034G2331</b>



Capacities

Range -40°C to +10°C

SI units

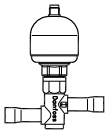
	t <sub>e</sub> [°C]	Rated capacity [kW]															
		ETS 12½								ETS 25							
		Pressure drop Δp [bar]															
		2	4	6	8	10	12	14	16	2	4	6	8	10	12	14	16
R410A	-40	46.4	60.0	68.1	73.5	77.3	79.9	81.6	82.6	95.3	123.2	140.0	151.1	158.8	164.1	167.7	169.8
	-30	45.2	59.0	67.3	73.0	76.9	79.7	81.6	82.7	92.9	121.2	138.4	150.0	158.1	163.8	167.7	170.1
	-20	43.6	57.4	65.9	71.7	75.8	78.7	80.7	82.0	89.6	117.9	135.4	147.4	155.8	161.8	165.9	168.6
	-10	41.6	55.2	63.7	69.6	73.8	76.8	78.9	80.3	85.5	113.5	131.0	143.1	151.7	157.9	162.2	165.0
	-5	40.5	53.9	62.4	68.3	72.5	75.5	77.6	79.0	83.3	110.8	128.2	140.3	149.0	155.2	159.6	162.5
	10	36.7	49.2	57.3	63.0	67.1	70.1	72.2	73.5	75.4	101.2	117.8	129.5	137.9	144.0	148.3	151.2
R407C	-40	42.1	52.8	58.6	62.0	63.9	64.9	65.0	64.6	86.5	108.5	120.5	127.5	131.4	133.3	133.6	132.7
	-30	41.9	53.0	59.2	63.0	65.2	66.3	66.7	66.4	86.0	109.0	121.7	129.4	133.9	136.3	137.1	136.6
	-20	41.2	52.8	59.3	63.4	65.8	67.2	67.8	67.8	84.7	108.5	121.9	130.2	135.3	138.2	139.4	139.3
	-10	40.2	52.0	58.8	63.1	65.9	67.5	68.3	68.4	82.6	106.9	120.9	129.8	135.4	138.7	140.3	140.6
	-5	39.6	51.4	58.4	62.8	65.6	67.3	68.2	68.4	81.3	105.7	120.0	129.0	134.9	138.4	140.2	140.6
	10	37.1	48.9	56.0	60.6	63.7	65.5	66.7	67.1	76.3	100.5	115.0	124.6	130.9	134.8	137.1	138.0
R22	-40	40.2	51.3	57.9	62.1	65.0	66.9	68.0	68.6	82.6	105.5	118.9	127.7	133.6	137.5	139.8	141.1
	-30	39.8	51.3	58.1	62.6	65.7	67.7	69.1	69.8	81.8	105.4	119.4	128.7	135.0	139.2	142.0	143.5
	-20	39.1	50.8	57.9	62.6	65.9	68.1	69.6	70.4	80.3	104.4	118.9	128.7	135.4	140.0	143.0	144.8
	-10	38.0	49.9	57.1	62.1	65.5	67.9	69.5	70.5	78.1	102.5	117.4	127.5	134.6	139.5	142.8	144.9
	-5	37.4	49.3	56.6	61.6	65.1	67.5	69.2	70.2	76.9	101.2	116.3	126.5	133.7	138.8	142.2	144.4
	10	35.2	46.8	54.1	59.2	62.9	65.4	67.2	68.4	72.3	96.2	111.3	121.7	129.2	134.5	138.2	140.6
R134a	-40	35.6	43.2	46.8	48.5	49.0	48.6	47.7	46.3	73.1	88.8	96.3	99.7	100.7	100.0	98.0	95.1
	-30	35.8	44.0	48.0	50.0	50.7	50.6	49.9	48.6	73.5	90.4	98.6	102.7	104.2	104.0	102.5	99.9
	-20	35.6	44.3	48.8	51.1	52.1	52.2	51.7	50.6	73.3	91.1	100.2	105.0	107.0	107.3	106.2	104.0
	-10	35.2	44.3	49.1	51.7	53.0	53.3	53.0	52.1	72.3	91.0	100.9	106.2	108.8	109.6	108.9	107.1
	-5	34.8	44.1	49.0	51.8	53.2	53.7	53.4	52.6	71.6	90.6	100.8	106.4	109.3	110.3	109.8	108.2
	10	33.3	42.8	48.1	51.2	53.0	53.7	53.8	53.2	68.3	88.0	98.9	105.3	108.9	110.4	110.5	109.4
R404A	-40	31.9	39.6	43.4	45.2	45.9	45.8	45.0	43.8	65.7	81.4	89.2	93.0	94.3	94.0	92.5	90.0
	-30	31.5	39.5	43.6	45.8	46.7	46.7	46.2	45.1	64.7	81.2	89.7	94.0	95.9	96.1	94.9	92.8
	-20	30.7	39.0	43.3	45.7	46.9	47.1	46.8	45.9	63.0	80.1	89.1	94.0	96.3	96.9	96.1	94.3
	-10	29.5	37.9	42.5	45.1	46.4	46.9	46.7	45.9	60.7	78.0	87.4	92.7	95.4	96.3	95.9	94.4
	-5	28.9	37.3	41.9	44.6	46.0	46.5	46.3	45.6	59.4	76.6	86.1	91.6	94.5	95.5	95.2	93.8
	10	26.5	34.6	39.2	41.9	43.5	44.1	44.1	43.5	54.4	71.0	80.5	86.2	89.3	90.6	90.6	89.4

Correction for subcooling Δt<sub>sub</sub>

The evaporator capacities used must be corrected if subcooling deviates from 4 K (7.2°F). The corrected capacity can be obtained by

dividing the required evaporator capacity by the correction factor below. Selections can then be made from the tables above.

Correction factor	Δt <sub>sub</sub>									
	4 K	10 K	15 K	20 K	25 K	30 K	35 K	40 K	45 K	50 K
	7.2°F	18°F	27°F	36°F	45°F	54°F	63°F	72°F	81°F	90°F
R22	1.00	1.06	1.11	1.15	1.20	1.25	1.30	1.35	1.39	1.44
R410A	1.00	1.08	1.15	1.21	1.27	1.33	1.39	1.45	1.50	1.56
R407C	1.00	1.08	1.14	1.21	1.27	1.33	1.39	1.45	1.51	1.57
R134a	1.00	1.08	1.13	1.19	1.25	1.31	1.37	1.42	1.48	1.54
R404A / R507	1.00	1.10	1.20	1.29	1.37	1.46	1.54	1.63	1.70	1.78

**Note:**  
Insufficient subcooling can produce flash gas.

Capacities

Range -40°F to +50°F

US units

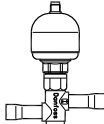
	t <sub>e</sub> [°F]	Rated capacity [TR]															
		ETS 12½								ETS 25							
		Pressure drop Δp [psig]															
		40	60	80	100	125	150	175	200	40	60	80	100	125	150	175	200
R410A	-40	14.9	17.2	18.9	20.1	21.3	22.1	22.7	23.2	30.7	35.5	38.8	41.4	43.7	45.5	46.7	47.6
	-20	14.6	16.9	18.6	19.9	21.1	22.0	22.7	23.1	29.9	34.8	38.3	40.9	43.4	45.2	46.6	47.6
	0	14.0	16.4	18.1	19.4	20.7	21.6	22.3	22.8	28.8	33.7	37.2	39.9	42.5	44.4	45.9	46.9
	20	13.3	15.7	17.4	18.7	20.0	20.9	21.6	22.2	27.4	32.2	35.7	38.4	41.0	43.0	44.5	45.5
	40	12.5	14.7	16.4	17.7	18.9	19.9	20.6	21.1	25.7	30.3	33.7	36.4	38.9	40.9	42.3	43.4
	50	12.0	14.2	15.8	17.1	18.3	19.2	19.9	20.5	24.7	29.2	32.5	35.1	37.6	39.6	41.0	42.1
R407C	-40	13.4	15.2	16.3	17.2	17.8	18.2	18.4	18.5	27.5	31.2	33.6	35.3	36.7	37.5	37.9	38.0
	-20	13.4	15.2	16.5	17.4	18.2	18.6	18.9	19.0	27.5	31.3	33.9	35.8	37.3	38.3	38.8	39.1
	0	13.2	15.1	16.5	17.4	18.3	18.8	19.2	19.3	27.1	31.1	33.9	35.9	37.6	38.7	39.4	39.7
	20	12.8	14.8	16.3	17.3	18.2	18.8	19.2	19.4	26.4	30.5	33.4	35.5	37.4	38.6	39.4	39.9
	40	12.4	14.4	15.8	16.9	17.8	18.5	18.9	19.2	25.4	29.5	32.5	34.7	36.6	38.0	38.9	39.4
	50	12.1	14.1	15.5	16.6	17.5	18.2	18.7	18.9	24.8	28.9	31.9	34.1	36.1	37.4	38.4	38.9
R22	-40	12.9	14.8	16.1	17.1	18.0	18.6	19.0	19.3	26.5	30.3	33.1	35.1	36.9	38.2	39.1	39.7
	-20	12.8	14.7	16.1	17.2	18.1	18.8	19.3	19.6	26.3	30.3	33.1	35.3	37.2	38.7	39.7	40.4
	0	12.6	14.6	16.0	17.1	18.1	18.8	19.4	19.8	25.8	29.9	32.9	35.1	37.2	38.7	39.8	40.6
	20	12.2	14.2	15.7	16.8	17.9	18.7	19.3	19.7	25.1	29.3	32.3	34.6	36.8	38.4	39.6	40.4
	40	11.7	13.8	15.3	16.4	17.5	18.3	18.9	19.3	24.1	28.3	31.4	33.7	35.9	37.6	38.9	39.7
	50	11.5	13.5	15.0	16.1	17.2	18.0	18.6	19.1	23.6	27.7	30.8	33.1	35.4	37.4	38.3	39.2
R134a	-40	11.2	12.4	13.1	13.6	13.9	13.9	13.8	13.6	22.9	25.5	27.0	27.9	28.5	28.6	28.4	27.9
	-20	11.3	12.6	13.5	14.0	14.3	14.5	14.5	14.3	23.2	26.0	27.7	28.8	29.5	29.8	29.7	29.3
	0	11.3	12.7	13.7	14.3	14.7	14.9	14.9	14.8	23.2	26.2	28.1	29.3	30.2	30.6	30.7	30.4
	20	11.2	12.7	13.7	14.4	14.9	15.1	15.2	15.2	22.9	26.1	28.1	29.5	30.6	31.1	31.3	31.2
	40	10.9	12.5	13.5	14.3	14.8	15.2	15.3	15.3	22.4	25.6	27.8	29.3	30.5	31.2	31.5	31.5
	50	10.7	12.3	13.4	14.1	14.8	15.3	15.1	15.3	22.0	25.3	27.5	29.1	30.3	31.1	31.4	31.4
R404a	-40	10.1	11.4	12.1	12.6	12.9	13.1	13.0	12.8	20.8	23.4	25.0	25.9	26.6	26.8	26.7	26.4
	-20	10.0	11.3	12.2	12.7	13.1	13.3	13.3	13.2	20.6	23.3	25.0	26.2	27.0	27.3	27.4	27.1
	0	9.8	11.1	12.0	12.6	13.1	13.4	13.4	13.3	20.0	22.9	24.8	26.0	27.0	27.4	27.5	27.4
	20	9.4	10.8	11.7	12.4	12.9	13.2	13.3	13.2	19.3	22.2	24.1	25.4	26.5	27.0	27.3	27.2
	40	8.9	10.3	11.2	11.9	12.4	12.7	12.9	12.8	18.2	21.1	23.0	24.4	25.5	26.1	26.4	26.4
	50	8.6	9.9	10.9	11.5	12.1	12.4	12.5	12.5	17.6	20.4	22.4	23.7	24.9	25.5	25.8	25.8

Correction for subcooling Δt<sub>sub</sub>

The evaporator capacities used must be corrected if subcooling deviates from 4 K (7.2°F). The corrected capacity can be obtained by

dividing the required evaporator capacity by the correction factor below. Selections can then be made from the tables above.

Correction factor	Δt <sub>sub</sub>									
	4 K 7.2°F	10 K 18°F	15 K 27°F	20 K 36°F	25 K 45°F	30 K 54°F	35 K 63°F	40 K 72°F	45 K 81°F	50 K 90°F
R22	1.00	1.06	1.11	1.15	1.20	1.25	1.30	1.35	1.39	1.44
R410A	1.00	1.08	1.15	1.21	1.27	1.33	1.39	1.45	1.50	1.56
R407C	1.00	1.08	1.14	1.21	1.27	1.33	1.39	1.45	1.51	1.57
R134a	1.00	1.08	1.13	1.19	1.25	1.31	1.37	1.42	1.48	1.54
R404A / R507	1.00	1.10	1.20	1.29	1.37	1.46	1.54	1.63	1.70	1.78

**Note:**  
Insufficient subcooling can produce flash gas.

Dimension and weight for ETS 12½ and 25

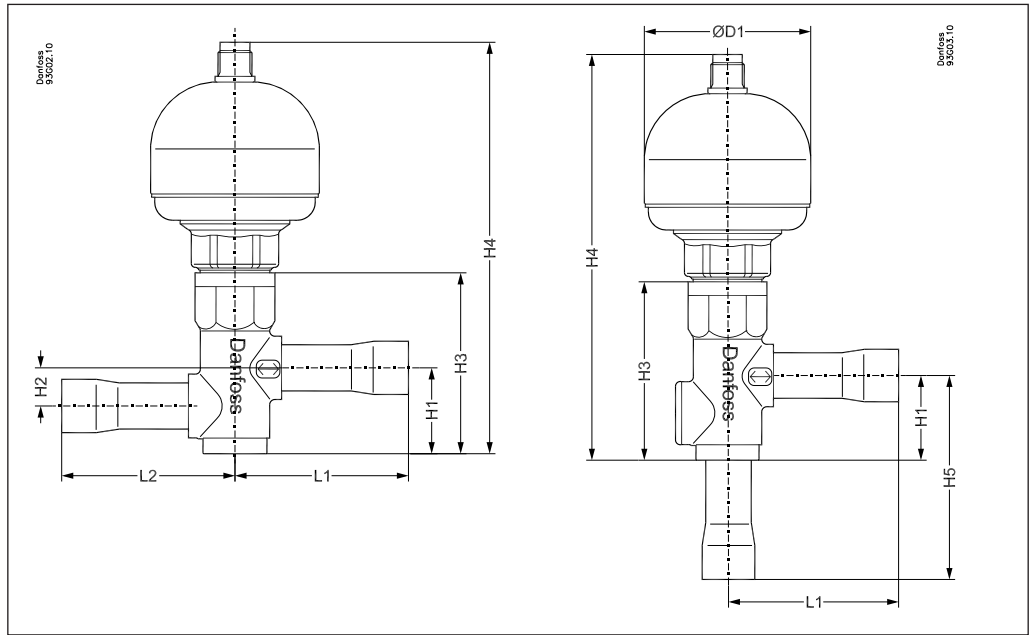

Type	Connections, ODF solder		H <sub>1</sub>		H <sub>2</sub>		H <sub>3</sub>		H <sub>4</sub>		H <sub>5</sub>		L <sub>1</sub>		L <sub>2</sub>		ØD <sub>1</sub>		Weight	
	In × out	In × out	mm	in.	mm	in.	mm	in.	mm	in.	mm	in.	mm	in.	mm	in.	mm	in.	kg	lb.
ETS 12½ straight	½ × ½	12 × 12	30	1.2	13	0.5	64	2.5	145	5.7			60	2.4	60	2.4	58	2.3	0.7	1.5
	5/8 × 5/8	16 × 16																		
	7/8 × 7/8	22 × 22																		
ETS 25 angle	½ × ½	12 × 12	30	1.2			64	2.5	145	5.7	74	2.9	60	2.4						
	5/8 × 5/8	16 × 16																		
	7/8 × 7/8	22 × 22																		

