

This is a reproduction of a library book that was digitized by Google as part of an ongoing effort to preserve the information in books and make it universally accessible.

Google™ books

<https://books.google.com>

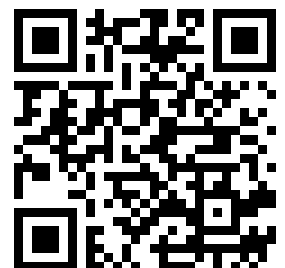

DOC.
D 301.26/17-2;
32450-01-8108

32450 01 8108

CDC 32450

PRECISION MEASURING EQUIPMENT SPECIALIST

(AFSC 32450)

Volume 1

Precision Measurement Career Development

DEPOSITORY

OCT 31 1984

UNIVERSITY OF ILLINOIS
AT URBANA-CHAMPAIGN



Extension Course Institute
Air University

Prepared by
MSgt William E. Yarbrough, Jr., and TSgt Donald H. Biesecker
3450 Technical Training Group
3400 Technical Training Wing (ATC)
Lowry AFB, Colorado 80230

Reviewed by: Richard B. Taylor, Education Specialist
Edited by: Jane S. Allen
Extension Course Institute (ATC/AU)
Gunter AFS, Alabama 36118



3450 TECHNICAL TRAINING GROUP
3400 TECHNICAL TRAINING WING (ATC)
LOWRY AIR FORCE BASE, COLORADO

EXTENSION COURSE INSTITUTE, GUNTER AIR FORCE STATION, ALABAMA

THIS PUBLICATION HAS BEEN REVIEWED AND APPROVED BY COMPETENT PERSONNEL OF THE PREPARING COMMAND
IN ACCORDANCE WITH CURRENT DIRECTIVES ON DOCTRINE, POLICY, ESSENTIALITY, PROPRIETY, AND QUALITY.

DOL.
D301.26/17-2:
32450-01-8108

P r e f a c e

THE TECHNICAL information and principles that you will need to operate, repair, and calibrate precision measuring equipment (PME) are included in this CDC. The material will help you develop the skills you need for 5-level performance in the base precision measurement equipment laboratory (BPMEL). These skills are identified in the Specialty Training Standard (STS) for the Precision Measuring Equipment Career Field.

This volume of your CDC is entitled *Precision Measurement Career Development*, because it teaches skills and knowledges—required for your career progression—that are career oriented as opposed to the job-task oriented skills and knowledges taught in the remaining volumes of the CDC. This volume teaches skills, knowledges, and principles related to the Air Force career program, proficiency advancement in the 324X0 career ladder, duties assigned a PME specialist, the Weighted Airman Promotion System (WAPS), operational security, personnel and shop safety principles and practices, the Air Force technical order system and PME related administrative and commercial publications, the Air Force maintenance management program, the USAF calibration program, laboratory practices, and supervision, and soldering techniques and handtools.

Modules 10009 and 10004, referenced in the text, are included as separate inclosures.

The inclusion of names of any specific commercial product, commodity, or service in this publication is for information purposes only and does not imply indorsement by the Air Force.

Direct your questions or comments relating to the accuracy or currency of this volume to the course author: 3450 TCHTG/TTMYM, ATTN: MSgt William E. Yarbrough, Jr., Lowry AFB CO 80230. If you need an immediate response, call the author, AUTOVON 926-4270, between 0700 and 1530 MST, Monday through Friday. (NOTE: Do not use the suggestion program to submit changes or corrections for this course.)

If you have questions on course enrollment or administration, or on any of ECI's instructional aids (Your Key to a Successful Course, Behavioral Objective Exercises, Volume Review Exercise, and Course Examination), consult your education officer, training officer, or NCO, as appropriate. If this person can't answer your questions, send them to ECI, Gunter AFS AL 36118, preferably on ECI Form 17, Student Request for Assistance.

This volume is valued at 36 hours (12 points). These hours and points include those assigned to the modules that you will study in conjunction with Chapter 1 and 5.

Material in this volume is technically accurate, adequate, and current as of November 1980.

Contents

	<i>Page</i>
<i>Preface</i>	iii
<i>Chapter</i>	
1 PME Career Field Requirements	1
2 Operational Security	9
3 PME and Personnel Safety	13
4 Air Force Publications	29
5 Maintenance Management	41
6 USAF Calibration Program, Laboratory Practices, and Supervision	43
7 Soldering Techniques and Handtools	66
<i>Bibliography</i>	80
<i>Answers for Exercises</i>	81

NOTE: In this volume, the subject matter is developed by a series of student-centered objectives. Each of these carries a three-digit number and is in boldface type. Each sets a learning goal for you. The text that follows the objective gives you the information you need to reach that goal. The exercises following the information give you a check on your achievement. When you complete them, see whether your answers match those in the back of this volume. If your response to an exercise is incorrect, review the objective and its text.

PME Career Field Requirements

CAREER PROGRESSION in the Air Force depends on completion of prescribed training programs. Graduation from the technical school course at Lowry AFB marked the end of your first phase of career training which qualified you for your present assignment. Advancement in your career field depends on additional training and experience. The first phase of additional training began when you enrolled in this Career Development Course (CDC). Completion of this course will broaden your scope of your Air Force specialty. You will develop technical skills needed for advancement in your career field by diligent and faithful performance of specific tasks assigned to you. When you have achieved these two training goals, your supervisor will certify that you are eligible for advancement.

Career success in the Air Force is closely related to your attitude toward your job. To be successful in any career, the job at hand must be accomplished with interest and enthusiasm. The adage "Where there is a will, there is a way" holds true in every phase of your present assignment. There is no greater motivation for success in your career than a full understanding of the importance of your role in support of the Air Force mission.

In this chapter many factors are presented that directly affect your progression in the precision measuring equipment (PME) career ladder. Since career progression is primarily your responsibility, keep the following in mind as you study this CDC.

An individual's career progression, including promotion in the Air Force, is directly related to the efforts expended by the officer or airman to attain and maintain qualification in his or her specialty. Therefore, attaining and maintaining this qualification are primarily the responsibility of the individual. Facilities for self-improvement such as off-duty education, ECI courses, technical training, Career Development Courses, and self-study guides are available or can be made available to all individuals. Each officer and airman is encouraged to enhance his or her technical qualifications as well as professional and military knowledge.

You can see that working your way through this CDC is one of your responsibilities toward your career progression. As you study this chapter, you will learn of several others responsibilities.

1-1. Training

On-the-Job-Training

NOTE: For objectives 001–043, study the same numbered objectives in Module 10009, *On-the-Job Training (5-Skill Level)*, which accompanies this volume. When you complete Module 10009, return to the text.

Module 10009 On-the-Job Training (5-Skill Level)

<i>CDC 32450-1 Objectives</i>	<i>Module 10009 Objectives</i>
001	001
002	002
003	003
004	004
005	005
006	006
007	007
008	008
009	009
010	010
011	011
012	012
013	013
014	014
015	015
016	016
017	017
018	018
019	019
020	020
021	021
022	022
023	023
024	024
025	025
026	026
027	027
028	028
029	029
030	030

031	031
032	032
033	033
034	034
035	035
036	036
037	037
038	038
039	039
040	040
041	041
042	042
043	043

1-2. Career Ladder Progression

Advancement in your AFS is dependent on your attainment of the specific skills and knowledges required to perform the duties and responsibilities of your AFSC. These duties and responsibilities are explained in your specialty description contained in AFR 39-1, Airman Classification Regulation. The training needed to qualify you to fulfill these duties and responsibilities is spelled out in the Specialty Training Standard (STS) for your AFS. Training requirements for your specialty are outlined in the STS in terms of subject knowledge levels, task knowledge levels, and task performance levels.

Training for the 3 skill level in the Avionics Systems Career Field comes primarily through the basic technical course. On-the-job training (OJT) is the primary means of upgrading to the 5 and 7 skill levels. However, advanced technical courses are offered for some specialties. When such courses are available, upgrade training can be achieved by OJT and completion of the advanced course.

In this brief section, we discuss the basic documents that outline your upgrade training requirements and the training programs normally used to provide upgrade training.

044. State the source document for all training programs and tell what the Specialty Training Standard (STS) shows.

Specialty Training Standard (STS). All training programs begin with AFR 39-1. How is this done? First of all, the STS is developed from the specialty descriptions in this regulation. Your STS is broken down into tasks that you must be able to perform and knowledges you must have. These tasks and knowledges are derived from the duties and responsibilities section of your specialty description in AFR 39-1. The STS shows:

- a. The extent to which trainees should be trained on each task in order to qualify them for upgrading.
- b. The extent to which formal courses and CDCs provide training on each of the listed subject and task knowledges.

There are numerous reasons why you should be acquainted with your STS. The STS is the authority that establishes the content of this CDC. It also establishes the content of the Job Proficiency Guide (JPG). As a trainer you

are required to certify that a trainee has completed various phases of training. And, as a trainee, you can see from an STS what knowledges are required of you.

An extract from an STS is shown in figure 1-4 of the OJT module you just completed. The format of all STSs is essentially the same. Column 1 lists the tasks, knowledges, and technical references necessary for an airman to perform duties in the AFS. Columns 2A, 3A, and 4A show the minimum proficiency recommended for each task or knowledge at the 3, 5, and 7 skill levels. The proficiency code key, shown in figure 1-3 of the OJT module, is included in each STS. This code key states the meaning of the number and letter codes.

Exercises (044):

1. Where do the tasks and knowledges in the STS originate?
2. What does the STS show?

1-3. Duties of the AFSC

You were awarded the 3-level AFSC upon graduation from the basic technical school course. As soon as you were assigned to a using organization, you were placed on upgrade training to the 5-level AFSC. Now, although you hold a 3-level AFSC, you are performing the 5-level duties. Later on in your career, you will perform duties as a 7 level and hopefully make it to the 9 level.

Paragraph 2 of each specialty description contained in AFR 39-1 outlines the duties and responsibilities required of the pFSC. Duties and responsibilities of the partially trained semiskilled 3-level specialist and the fully trained skilled specialist are identical. Thus, the 3- and 5-skill-level specialty descriptions for each AFS are one and the same. Because 7-level duties and responsibilities are different from the 3- and 5-level duties and responsibilities for each AFS, a separate specialty description is required.

045. Using AFS description extracts, give the appropriate skill level for described duties and responsibilities.

The complete and current specialty description for your AFS is contained in AFR 39-1. To show you how duties and responsibilities are described in a specialty description and to allow you to analyze and compare 3-, 5-, and 7-level duties and responsibilities, we have included specialty descriptions 32450 and 32470 (figs. 1-1A, 1-1B, 1-2A, and 1-2B).

As you read the specialty descriptions, you will recognize that they refer only to the precision measuring equipment AFS. Compare the duties and responsibilities of the 3 and 5 level to those of the 7 level. As you can see, the 7 level has considerably more to do and is responsible for more than the 5 level. This agrees with the STS code levels in that a 7 level requires more detailed training than a 5 level.

AIRMAN AIR FORCE SPECIALTY

PRECISION MEASURING EQUIPMENT SPECIALIST

1. SPECIALTY SUMMARY

Aligns, inspects, troubleshoots, repairs, overhauls, modifies, calibrates, and certifies electrical/electronic precision measurement equipment including working standards, using authorized maintenance and calibration procedures and equipment.

2. DUTIES AND RESPONSIBILITIES

a. *Analyzes and isolates malfunctions in precision measuring equipment:* Analyzes routine maintenance problems in precision measuring equipment including working standards, by studying block diagrams, schematics, logic diagrams, and pictorial drawings. Traces circuits and identifies operating characteristics of equipment to determine malfunctions. Isolates area of malfunctions, resolves routine maintenance problems, and assists technician in resolving complicated maintenance problems. Determines corrective action to alleviate similar recurrences. Initiates data input to maintenance data collection system. Diagnoses recurring malfunctions to assist technician in initiation of corrective action to include material deficiency reports, proposed modifications, or other appropriate means. Assists technician in developing or recommends revised maintenance procedures. Studies maintenance policy and procedure in manufacturer's handbooks, technical orders, and organizational maintenance directives for precision measuring equipment including working standards.

b. *Aligns, repairs, modifies, and overhauls precision measuring equipment:* Disassembles and inspects assemblies and subassemblies of precision measuring equipment and working standards using gages, instruments, and special tools. Assists technician in disassembly and inspection of intricate assemblies and subassemblies. Aligns, repairs, overhauls, and modifies assemblies and subassemblies of precision measuring equipment and working

standards in accordance with applicable publications. Assists technician in alignment, repair, overhaul, and modification of intricate assemblies and subassemblies. Removes and replaces components such as capacitors, resistors, tubes, and transistors using appropriate hand tools. Requisitions replacement parts through appropriate supply channels.

c. *Inspects, calibrates, and certifies precision measuring equipment including working standards:* Inspects and calibrates precision measuring equipment and working standards to determine operational status. Studies inspection findings to determine need for corrective action. Inspects installed and repaired components and subassemblies for proper standards of maintenance. Assists technician in studies to determine trends of malfunctioning components. Reviews material deficiency reports, technical orders, and other technical publications regarding working standards and precision measuring equipment. Performs certification of precision measuring equipment including working standards.

d. *Supervises precision measuring equipment personnel:* Assigns repair functions to subordinates and reviews completed repairs to insure compliance with policies, preventive maintenance directives, and technical orders. Conducts on-the-job training programs for precision measuring equipment personnel.

Figure 1-1A. Extract from AFM 39-1, AFSCs 32430/32450, specialty descriptions.

3. SPECIALTY QUALIFICATIONS

a. *Knowledge*: Knowledge of electrical theory, electronics, and physics; measurement techniques and laboratory practices; operating principles of precision measuring equipment including working standards; analysis of block, schematic, wiring, and logic diagrams and technical publications; use and care of precision measurement equipment and working standards; and metrology is *mandatory*. Possession of mandatory knowledge will be determined in accordance with AFR 35-1.

b. *Education*:

(1) Completion of high school or GED equivalency is *mandatory*.

(2) Completion of high school courses in physics, trigonometry, and algebra is desirable.

c. *Experience*: Experience in functions such as inspecting, troubleshooting, aligning, repairing, overhauling, modifying, calibrating, and certifying electrical/electronic precision measuring equipment including working standards is *mandatory*.

d. *Training*: Completion of a basic precision measuring equipment maintenance course is *mandatory* prior to the award of the Semiskilled AFSC.

e. *Other*:

(1) Normal color vision as defined in AFR 160-43 is mandatory.

(2) A minimum aptitude level of Electronic 80 is *mandatory*.

4. SPECIALTY DATA

a. *Grade Spread*:

Airman first-class through staff sergeant	32450
Airman first-class	32430

b. *Related D.O.T. Job*:

Standards-Laboratory Technician ----- 019.281

c. *Related DOD Occupational Subgroup*:
198

Figure 1-1B. Extract from AFM 39-1, AFSCs 32430/32450, specialty qualifications.

Paragraphs a, b, and c of the 3-, 5-, and 7-level specialty descriptions outline very similar duties and responsibilities. However, duties of the 7-level technician are more extensive in some areas than the 5-level specialist. The greatest differences are in the area of supervision. Observe that the 5-level specialist conducts OJT and supervises subordinates to insure the application of correct procedures and compliance with applicable directives. In contrast, the 7-level technician establishes work assignments, priorities, and performance standards. In addition, the 7 level insures availability of required tools, equipment, and parts, and evaluates personnel performance.

We did not include an example of a 9-skill-level specialty description. However, the 9-level superintendent deals primarily with matters of supervision, organization, and management. If you are interested in the complete 9-level job description for your AFS, look in AFR 39-1.

Exercises (045):

1. At which skill level are you most likely to assist in the removal, repair, installation, and checkout of avionics systems components and/or equipment?
2. Which skill level includes the responsibility for conducting OJT programs?

3. Which skill level performs the tasks necessary to install a calibration standard?

4. Which skill level is concerned with establishing and conducting OJT programs?

1-4. Weighted Airman Promotion System (WAPS)

Perhaps one of the most common areas of concern among Air Force enlisted personnel is that of promotions. Complaints over a period of years from the enlisted force caused the Air Staff, in 1966, to initiate a review of the promotion process to determine the cause of the complaints. As a result of this review, a new promotion system, referred to as the Weighted Airman Promotion System (WAPS), was initiated. The new promotion system selects airmen for promotion to the grades of E-4 through E-7, using standard weighted criteria. It provides each nonselected airman with a promotion score notice. It increases the visibility of selection factors which gives airmen a better understanding of the promotion system. Since all airmen in a given AFSC and grade compete with each other worldwide, it insures a more equitable method of selecting for promotion.

PRECISION MEASURING EQUIPMENT TECHNICIAN

1. SPECIALTY SUMMARY

Aligns, inspects, repairs, troubleshoots, overhauls, modifies, calibrates, and certifies precision measuring equipment including calibration and working standards, using advanced principles of metrology and calibration standards; and supervises precision measuring equipment activities.

2. DUTIES AND RESPONSIBILITIES

a. *Analyzes and isolates malfunctions in precision measuring equipment:* Analyzes complex and unusual maintenance problems in precision measuring equipment including working and calibration standards, using block diagrams, schematics, logic diagrams, and pictorial drawings. Traces circuits and analyzes operating characteristics of equipment to determine malfunctions. Isolates malfunctions to resolve complicated maintenance problems. Determines corrective repairs to prevent recurrences. Recommends changes to reliability factors against which equipment is periodically checked to assist in development of corrective indexes for calibration standards, working standards, and precision measuring equipment. Determines calendar or hour time replacement factors for components of sub-systems to insure high reliability factors for maximum in-commission time. Diagnoses recurring malfunctions and initiates corrective action by submission of material deficiency reports, proposed modifications, or other appropriate means. Develops and recommends revised maintenance procedures. Interprets maintenance policy and procedure in accordance with manufacturer's handbooks, technical orders, and organizational maintenance directives. Establishes technical publications file requirements.

b. *Aligns, modifies, repairs, and overhauls precision measuring equipment including calibration and working standards:* Disassembles and inspects intricate assemblies and subassemblies of precision measuring equipment including calibration and working standards, using gages, instruments, and special tools. Installs calibration standards. Overhauls and repairs subassemblies of precision measuring equipment including calibration and working standards and performs difficult system alignment. Aligns pre-

cision measuring equipment including calibration and working standards. Removes and replaces components such as capacitors, resistors, and transformers using appropriate hand tools. Modifies precision measuring equipment including calibration and working standards in accordance with applicable technical publications. Requisitions replacement parts through appropriate supply channels.

c. *Inspects, calibrates, and certifies precision measuring equipment:* Inspects and calibrates precision measuring equipment including calibration and working standards to determine operational status. Interprets inspection findings to determine adequacy of corrective action. Inspects installed and repaired components and subassemblies to assure proper standards of maintenance. Analyzes and studies material deficiency reports to determine trend of malfunctioning components. Reviews material deficiency reports, technical orders, and other technical publications regarding precision measuring equipment. Inspects and approves completed modifications accomplished in accordance with technical directives. Submits recommendations for modification or precision measuring equipment including calibration and working standards. Evaluates justification and practicability of proposed modifications. Certifies precision measuring equipment including calibration and working standards.

d. *Supervises precision measuring equipment personnel:* Establishes work methods, production controls, and performance standards. Insures availability of calibration standards, working standards, maintenance equipment, tools, and spare parts. Assigns repair functions and establishes priorities for completing repairs. Conducts on-the-job training program for precision measuring equipment personnel.

Figure 1-2A. Extract from AFM 39-1, AFSC 32470, specialty description.

3. SPECIALTY QUALIFICATIONS

a. *Knowledge*: Knowledge of electrical theory, electronics, and physics; operating principles of precision measuring equipment including calibration and working standards; interpretation of schematic wiring diagrams, blueprints, and technical publications; use and care of calibration standards, working standards, precision measuring equipment, and radioactive sources; and metrology is *mandatory*. Possession of mandatory knowledge will be determined in accordance with AFR 35-1.

b. *Education*:

(1) Completion of high school or GED equivalency is *mandatory*.

(2) Completion of high school courses in physics, trigonometry, and algebra is desirable.

c. *Experience*: Qualification as a Precision Measuring Equipment Specialist is *mandatory*. In addition, experience in performing or supervising functions such as operation, troubleshooting, maintenance, repair, and calibration of voltage, current, power, impedance, frequency, microwave, temperature, mechanical, and optical precision measuring equipment including calibration, working, and radiac standards is *mandatory*.

d. *Training*:

(1) Completion of an advanced precision measuring equipment maintenance course is desirable.

(2) Completion of an appropriate base level management course is desirable.

e. *Other*: Normal color vision as defined in AFR 160-43 is mandatory.

4. SPECIALITY DATA

a. *Grade Spread*: Staff sergeant through master sergeant.

b. *Related D.O.T. Job*:

Standards-Laboratory Technician-----019.281

c. *Related DOD Occupational Subgroup*:
198

Figure 1-2B. Extract from AFM 39-1, AFSC 32470, specialty qualifications.

046. Identify different WAPS factors with point values or other characteristics; and, given hypothetical situations, compute promotion points.

Basically, WAPS selects airmen for promotion based on the total score of certain weighted factors. These factors were selected to meet the following criteria. The factors had to (1) be predictive of success in the higher grade, (2) be measurable, and (3) apply universally to all airmen. The factors and the maximum scores you can achieve in each for E-4 through E-7 promotions are as follows:

<i>Factor</i>	<i>Maximum Points</i>
Specialty Knowledge Test (SKT)	100
Promotion Fitness Examination (PFE)	100
Time in Service (TIS)	40
Time in Grade (TIG)	60
Decorations	25
Performance Reports	135
Total	460

Under WAPS, all eligible airmen in the same pay grade and AFSC compete on a worldwide basis with each other for promotion. No greater number of promotions are made under WAPS than were made under the old promotion system. The number of vacancies still determines how many airmen in each pay grade and AFSC will be promoted each promotion cycle. Therefore, every eligible airman has a chance to compete for whatever is available.

Two of the keys to success in WAPS are the tests that eligible airmen must take. These are taken annually in

competition with all other airmen in the same pay grade and AFSC. These tests are the Specialty Knowledge Test and the Promotion Fitness Examination.

Specialty Knowledge Test (SKT). SKTs are developed by senior NCOs who hold 7- or 9-level AFSCs in the appropriate career field. These NCOs (called subject matter specialists) represent each major command that has a significant number of specialists assigned. While developing the SKT, the subject matter specialists work closely with test psychologists of the USAF Occupational Measurement Center (OMC) at Lackland AFB, Texas. Examination questions in the SKT measure your technical knowledge and are similar to the questions you will be asked for skill-level upgrading. SKTs are revised periodically to insure that they remain valid, reliable, and current.

All airmen eligible for promotion to E-4 through E-7 are given an SKT annually if one is published. You will be notified when you are scheduled to take the promotion tests. Before testing, you should prepare yourself by studying the references listed for your AFSC. The ECI Index of Study Reference Material is a list of the CDCs used as study reference material for the SKT. It is published semiannually to coincide with the Air Force WAPS cycles.

Promotion Fitness Examination (PFE). The PFE measures your knowledge of military subjects and management practices at a specific pay-grade level. This test is administered every cycle to new eligibles, normally at the same testing session as the SKT. As with the SKT, you can prepare yourself for the examination by reviewing reference materials available through your unit. Both the PFE and SKT are percentage scored.

Time in Service (TIS). Time in service, the third factor in WAPS, is computed by multiplying your total years of active Federal military service by 2. You are allowed up to a total possible score of 40 points for 20 years of active service.

To compute your TIS points, subtract the day, month, and year of your total active Federal military service date (TAFMSD) from the last date of the last month of the promotion cycle. Multiply full years by 2. Then add 1/6 point for each additional month.

Example:

	Year	Month	Day
Last Month of Promotion Cycle	1981	1 (Jan)	31
Minus TAFMSD	1969	5 (May)	25
	11	8	6
<hr/>			
Plus Incentive Day (for first day of service)			1
Total	11	8	7

11 years × 2 = 22 points
 8 months = 1½ points
 TIS Score = 23½ points

Time in Grade (TIG). Your time-in-grade score is computed at the rate of one-half point per full month in grade up to the maximum of 60 points for 120 months in grade. A period of over 15 days counts as a whole month.

To compute your TIG points, subtract the day, month, and year of your date of rank from the first day of the last month and year of the promotion cycle. Round off the result to the nearest whole month. Divide the total months by 2 to obtain TIG Year points.

Example:

	Year	Month	Day
First Day of Last Month of Promotion Cycle	1981	1 (Jan)	1
Minus Date of Rank	1977	3 (May)	1
	3	10	0
<hr/>			
Plus Incentive Day			1
Total	3	10	1

3 years, 10 months = 46 months
 TIG Score = 46 ÷ 2 = 23 points

Decorations. Decorations are assigned specific points according to their order of precedence. A total of 25 points is the maximum for this factor. Points allowed for each award are:

Medal of Honor	15
Air Force Cross	11
Distinguished Service Cross	11
Distinguished Service Medal	9
Silver Star	9
Legion of Merit	7
Distinguished Fly Cross	7
Airman's Medal	5
Soldier's Medal	5
Bronze Star	5
Meritorious Service Medal	5
Air Medal	3
Commendation Medal	3
Purple Heart	1

The same number of points is given for repeat awards and equivalent decorations earned in other U.S. Services, regardless of the grade held at the time you earned them.

To compute your points for decorations, multiply the points allowed for each decoration by the number of times you have been awarded that decoration and total the points.

Example: Assume that you have been awarded the Bronze Star (5 points), Air Medal (3 points) with two clusters, and the Commendation Medal (3 point).

Bronze Star	(5 × 1) = 5 points
Air Medal	(3 × 3) = 9 points
Commendation Medal	(3 × 1) = 3 points
Total	<u>17 points</u>

Airman Performance Report (APR). The APR will be used as a measure of your past job performance. It reflects the sum total of your capabilities as demonstrated in your daily actions. It also is an indication of your expected duty performance in future assignments within your career field. More than one-fourth of the WAPS score possible is the 135 points maximum allowed for APRs. The point score is computed by multiplying by 15 the average of the overall evaluation ratings on the most recent APRs you have received over the 5 years—not to exceed a total of 10 APRs.

You must know your APR overall evaluation for each of the most recent 10 APRs not to exceed 5 years from the eligibility cutoff date. Your career advisor can help you determine this.

On NCO ratings, the score will be in one of the 10 blocks (0 to 9) in the Overall Evaluation section. For lower graders, take the rating from the five blocks in Career Recommendations section. These five blocks are valued, from low to high, as follows—0, 4, 6, 8, 9.

Figure your average rating by dividing the total for all APR ratings by the number of APRs being considered. Figure your APR score by multiplying your average APR rating by 15.

Example: In the last 5 years you received five APRs with ratings of 7, 8, 9, 9, and 9. Scores on these five APRs total 42.

$$42 \div 5 \text{ (No. of APRs)} = 8.4 \text{ (Average)}$$

$$8.4 \times 15 = 126 = \text{Total Points}$$

APR Score 126 points

Visibility. One of the main features in the new system is visibility—you will know exactly what you are being judged

on compared with others of the same grade and CAFSC. You can see the importance of each promotion factor and its weight. You can figure your own score on known factors.

If you are not selected for promotion, you will get a written notice showing the scores you obtained on each factor, your total point score, and the cutoff score for promotion during that specific promotion cycle in your AFSC. This visibility feature shows you where you might improve your promotion potential.

You are able to compute your score and compare it with the maximum attainable score. You must remember, however, that you are competing against other airmen with your grade and AFSC worldwide. Remember also that under WAPS, the quota is applied only at HQ USAF so that cutoff scores are established Air Force wide for each AFSC.

<i>Score Sheet</i>	<i>Maximum Score</i>	<i>Your Score</i>
Specialty Knowledge Test	100	_____
Promotion Fitness Examination	100	_____
Time in Service	40	_____
Time in Grade	60	_____
Decorations	25	_____
Performance Reports	135	_____
Total	460	

If you have questions about how waps is going to affect your particular case, see your local career advisor. Your career advisor either has the answer or can tell you where to go for further assistance.

Exercises (046):

1. Under the WAPS system, what is the maximum amount of promotion points for the Specialty Knowledge Test?
2. A sergeant has received four APRs with overall evaluations of 9, 9, 8, and 9. How many promotion points will be given for these APRs?
3. Under WAPS, which area is worth more, time in service or decorations?
4. A particular staff sergeant has 5 years and 6 months time in grade; how many promotion points will be given for time in grade?
5. What areas are covered in the Promotion Fitness Examination?

Operational Security

AS A MEMBER of the Air Force, you encounter all types of information, much of which would be of aid to an enemy. Some of the information is obviously classified as indicated by a marked classification on the source documents. Not so obvious is the information which is not classified but which when lumped together with other data could affect some Air Force mission. This chapter helps you learn to recognize various types of information requiring security. It also tells you about Air Force security program.

2-1. Air Force Operational Security

All information about an Air Force operation needs protection because such information is valuable to our enemies. This protection is provided under the Air Force operational security (OPSEC) program. OPSEC is an overall security program relating to mission accomplishment. It is concerned with the information, actions, and activities that are sensitive in the sense that they can telegraph our punch to the enemy—they can give advance warning.

OPSEC is applicable to all peacetime and wartime missions whether operational or supporting. Every Air Force member has a responsibility to maintain operational effectiveness at the highest possible level. This responsibility includes an obligation to apply OPSEC principles and procedures in promoting overall security without detracting from operational effectiveness. You need to know this information to fulfill your OPSEC responsibilities.

047. Briefly define the historical aspect of operational security and state the purpose of the OPSEC program.

OPSEC History. The success or failure of most major combat operations depends upon the element of surprise. Before an operation can be started, people must be assembled, equipment and transportation massed, and numerous other activities completed. However, when preparing for an operation, we usually show definite patterns of behavior or action. These patterns can become warning signs to enemy intelligence collectors. They can show that an operation is underway or being planned. Attempting to gain information about planned operations is not new; it is an age-old practice. The activities of opposing forces are constantly monitored to obtain signs of planned operations. This is done because such forewarning may provide time to take countermeasures that reduce or eliminate any advantage that may have been created by surprise. In view of this, it is easy to see the need for assuring that sensitive information about our combat operations is controlled.

On the other hand, the need for controlling sensitive information is not as obvious if the information does not

seem to be related to a combat operation. Consequently, several Air Force studies were made to find out how sensitive information was being compiled by enemy intelligence sections. For the most part, these studies revealed that sensitive information about combat operations could be obtained, without anyone violating any security rules, by using nothing other than commonsense. For example, in Viet Nam, Security Police flight duty schedules and rosters were being posted in locations where foreign nationals could screen them. This was being done as much as 24 hours prior to the scheduled worktime. Moreover, these studies showed that just before a major airstrike against Viet Cong targets, we increased our security readiness postures and exercised more strict base entry procedures for foreign nationals.

How many security rules did this violate? NONE. Could these actions provide a trained enemy espionage agent with enough sensitive information to piece together a picture? By themselves, maybe not. But when combined with overheard comments like "We must be getting ready to hit Hanoi; they loaded 500 pounders (bombs) on every plane this afternoon," the picture begins to come into focus.

Under these conditions, the need for an Air Force-wide program to control and protect sensitive information became more and more visible. As a result, the OPSEC program came into being.

Purpose. OPSEC is concerned with keeping the tactical and strategic surprise on our side, by protecting information and activities affecting this principle. We must protect knowledge of our plans, resources, and limitations. The proper protection of classified information and material is part of OPSEC; so is the protection of seemingly trivial or insignificant unclassified information and actions that are related. In other words, we must protect information or actions that are sensitive. A simplified statement about the purpose of OPSEC is "to keep the advantage on our side." The successful completion of our mission and the use of OPSEC are greatly dependent upon each individual's recognizing what information and actions need protection. However, there is a point of diminishing returns in applying OPSEC. This point is reached when our overall security measures detract from operational effectiveness. There must be a balance between security and mission accomplishment.

Exercises (047):

1. How has history shown the need for an OPSEC program?
2. What is the purpose of OPSEC?

048. List the objectives of the OPSEC program and state the sources and types of information that could forewarn an enemy.

OPSEC Objectives. The OPSEC program is conducted on a full-time basis, as are Air Force programs for information and communications security. OPSEC is also similar to these programs in key elements, such as individual responsibility and need-to-know. Specifically, our OPSEC program has four major objectives:

- (1) Identify those portions of an operation that require protection.
- (2) Develop OPSEC procedures and techniques.
- (3) Systematically assess OPSEC status at all operational levels.
- (4) Document deficiencies and institute corrective actions.

Sources and Types of Information. There are many sources or possible sources of information that give the enemy advance warning. Generally, these can be placed in one of three categories that are common to any military activity: operations, procedures, and communications. Figure 2-1 presents typical intelligence indicators under each of these categories. Within each of the categories there are

numerous items of sensitive information. Examples of the types of information that need protection are:

- Objectives of the operation.
- Operation times and locations.
- Friendly and enemy forces involved.
- Known or suspected limitations.
- Methods of employment.
- Results of the operation.
- Sources of intelligence data.
- Methods of data collecting.

Exercises (048):

1. List the objectives of the OPSEC program?
2. What are the sources of information sought by the enemy?

	I CLASSIFY TOP SECRET IF DISCLOSURE COULD:	II CLASSIFY SECRET IF DISCLOSURE COULD:	III CLASSIFY CONFIDENTIAL IF DISCLOSURE COULD:	IV MARK FOR OFFICIAL USE ONLY IF DISCLOSURE COULD:
A INTELLIGENCE EFFORTS	REVEAL OWN SUCCESS AND/OR CAPABILITIES BY ALLOWING FULL EVALUATION OF EFFORT.	REVEAL FACT WE KNOW: POTENTIAL ENEMY MATERIAL, TROOP DISPOSITION, ETC.	COMPROMISE SOME INTELLIGENCE AND COUNTER INTELLIGENCE REPORTS.	REVEAL INFORMATION FURNISHED BY FOREIGN NATIONS IN CONFIDENCE.
B WEAPONS SYSTEMS	(1) DISCLOSE NUCLEAR DATA, (2) COMPROMISE RADICALLY NEW AND EXTREMELY IMPORTANT EQUIPMENT.	COMPROMISE DATA RELATING TO NEW DEVELOPMENTS.	REVEAL PRODUCTION AND PROCUREMENT OF MUNITIONS. ----- SOME TECHNICAL TRAINING MANUALS.	REVEAL CERTAIN TECHNICAL DATA RELATING TO ARMS WHICH ARE SUBJECT TO EXPORT LICENSING.
C FORCE COMPOSITION AND DEPLOYMENT	COMPROMISE WORLD-WIDE COMPOSITION AND DEPLOYMENT IN WAR PLANS.	REVEAL STRENGTH, IDENTITY, EQUIPMENT COMPOSITION, AND LOCATION OF UNITS ENGAGED IN HOSTILITIES.	REVEAL STRENGTH OF GROUND, NAVAL, AND AIR FORCES IN THE U.S. AND OVERSEAS.	REVEAL INFORMATION PERTAINING TO SPECIFIC UNIT IDENTIFICATION, CURRENT LOCATION, AND GENERAL NATURE OF EQUIPMENT. ----- ORDERS TO AN AREA OF UNDECLARED WAR.
D POLITICAL- MILITARY INFORMATION	(1) LEAD TO A DEFINITE BREAK IN DIPLOMATIC RELATIONS. (2) RESULT IN AN ARMED ATTACK AGAINST THE U.S. OR ITS ALLIES.	JEOPARDIZE INTERNATIONAL RELATIONS.		
E OPERATIONS	COMPROMISE STRATEGIC PLAN DOCUMENTING OVERALL CONDUCT OF WAR.	COMPROMISE PLANS THAT REVEAL MILITARY CAPABILITY OR PREPAREDNESS.	REVEAL OPERATIONAL AND TECHNICAL DOCTRINE/ ----- RADIO FREQUENCIES AND CALLSIGNS OF SPECIAL SIGNIFICANCE.	

Figure 2-1. Sample classification guide.

3. What type of information does the enemy use to gain advance warning?

049. Given hypothetical situations, determine, if OPSEC objectives and purposes have been met.

Lessons Learned. The main objective of OPSEC is to provide protection for our operations during the planning, execution, and after-action phases. Any actions that could affect the successful completion of an operation, or the protection of the mission, fall under OPSEC. One of the most important lessons we have learned about ourselves is the ease with which an enemy can obtain advance knowledge of our operations. We also learned that closely related to this was the apparent lack of importance attached to comments such as we used earlier in this section. Air Force studies of this area also showed that changes to our normal routines contributed to security weaknesses. Finally, and perhaps most startling, was the fact that the Air Force concern for its people was a major factor in creating security weaknesses. This was the result of getting the word out to everyone concerned, thus creating such a grapevine that in some instances the women and children on a base had almost as much knowledge about the what, when, where, why, and how of an operation as the person in charge.

On that account, we now know that you, the individual at the working level, should be aware of the intelligence impact your information and activity has in relation to the overall security of an operation. Therefore, to do our job under OPSEC, we must:

- a. Change only those procedures or actions that need to be changed.
- b. Learn to work with those procedures that are needed and cannot be changed.

The need for OPSEC is quite easy to see in combat operations. However, what of peacetime operation and projects? To answer a question with a question, "Why make the opportunity available?" For instance, recall, if you will, the types of operational information that should be protected. Generally, subjects, such as objective, time and location, forces, limitations, methods of employment, and data collection, results, and intelligence sources, should come to mind. The key point to communicating these subjects is *don't*, unless the person you are talking to has a need-to-know and a secure method of communication is used. This applies equally to combat operations and our peacetime operations.

Exercises (049):

In each of the following hypothetical situations, you are stationed at a Northern U.S. strategic missile base. You are assigned the job of determining if the base OPSEC purposes and objectives are being met. Your survey results in the following information; now you must decide by writing Yes or No in the space provided whether the OPSEC purposes and objectives were met in each situation. Explain.

1. The wife of the wing commander appears on the local TV talk show and discusses the importance and benefits of Air Force and local community relations.
2. Sitting at the base cafeteria, you overhear two enlisted missile crewmembers talking about a problem they had repairing a malfunctioning launch hoist at Juliet site.
3. On sick call, you overhear several dependent wives discussing the distances from their homes to Fox, George, and Romeo sites.
4. Your base newspaper has a large front-page story of how missile launch crews from your base won the first place award at the last missile competition at Vandenberg AFB, California.
5. At the base library you find a copy of a recent IG report and some portions of it are marked "(S)."
6. You learn that base reproduction is printing TDY orders for 50 missile crew personnel to attend a school at a classified location in order to learn about a revised missile launch system.

2-2. Other Security Programs

Just because you don't handle "classified" information or materials in PMEL doesn't mean you are exempt from taking part in the security program. Although the security programs are shown as separate entities, they are in reality closely related. As you read the following paragraph, this will be apparent and you will understand better why you do participate in the security program.

050. Characterize the various types of security programs by identifying specific actions of each.

OPSEC is concerned with keeping the tactical and strategic surprise on our side. This is accomplished by protecting information and activities relating to our plans, operations, resources, and limitations. The proper protection of the most trivial or insignificant unclassified information is part of OPSEC. However, there is a point when overall security measures detract from operational effectiveness. There must be a balance between security and mission accomplishment.

OPSEC and COMSEC are related because operations, obviously, must be communicated—plans change due to something that is going to happen or that already has happened (such as a planned military operation/exercise. COMSEC is the security of Air Force communication systems; whereas, OPSEC is the security of Air Force operations.

The other type of security is physical security. This means the direct or indirect influence of dissuading or deterring an enemy from starting hostile operations against the Air Force. The following paragraphs define enemy actions you may encounter that are considered physical security threats.

Subversion: This would be an attempt to overthrow some part of our existing policies and standards.

Infiltration: This is the act of filtering or sneaking into a place.

Sabotage: This is the act of damaging or destroying resources in order to impede the Air Force mission.

Coercion: Coercion is the act of restraining or constraining by physical or moral force such as threatening to harm a member of your family if you don't do something. Along these same lines are extortion/kidnapping/hostages.

Open attack: This involves situations that constitute an all-out attack against your base.

As you can see from these explanations, the three types of security are different. Yet, they all relate to each other. In

other words, don't talk (COMSEC) about your base's latest plan or mission (OPSEC) and be aware of suspicious acts (physical security) on and around your base.

An additional program is information security. The intent of this program is the protection of all information that is or might be of intelligence value. This means classified, unclassified, and for official use only.

There is one other security program and that is the industrial security program. This program is the combination of all the others put together but is basically for civilian industry (who makes and produces everything for the Government). Classified information in the hands of civilian industrial contractors must be protected.

Exercises (050):

1. Match the security action in column B with the most appropriate type of security program in column A.

Column A	Column B
___ (1) OPSEC.	a. The deterrence of enemy hostile action.
___ (2) COMSEC.	b. Protection of classified information the hands of a civilian contractor.
___ (3) Physical security.	c. Stopping the discussion of classified information on the telephone.
___ (4) Information security.	d. Keeping the tactical and strategic surprise on our side.
___ (5) Industrial security.	e. The protection of all information.

PME and Personnel Safety

THE NAMES “George Washington,” “Meriwether Lewis,” “Orville and Wilbur Wright,” “Robert Peary,” “Charles Lindbergh,” “John Glenn,” and “Neil Armstrong” are familiar to all Americans. When speaking of these men, all of us experience a feeling of pride because of their exploits. They were adventurous and daring, and demonstrated great courage when faced with danger. All have earned and rightfully deserve their places as national heroes.

Their ventures involved numerous risks which they minimized as much as possible because they were skillful, well trained, and exercised prudence. They were bold, but not foolhardy. They risked their lives, but only after careful preparation and planning.

Why is safety needed? The “product” of the Air Force is national defense. This is our business and the reason for our existence. To justify our existence, the quality of our “product” must be far superior to that of any competitor. It is a deadly serious business, conducted by professionals, and restricted by limited resources, and allows no room for waste. Accidents cause waste in the loss of services of highly trained personnel or in the use of essential material and complex equipment. It is impossible for any organization or business to produce effectively without eliminating waste. Therefore, when accidents are reduced, waste is reduced, and protection is increased.

As important as the productivity factor is, it is the humanitarian aspect of safety which is of primary concern to the Air Force. The protection of its people from harm is of fundamental importance. Unlike most civilian businesses whose safety efforts are directed at eliminating on-the-job accidents, the Air Force safety efforts are designed to give complete coverage regardless of duty status, location, or activity of its personnel.

Television, radio, and newspapers give daily reports of tragic accidents which annually account for the loss of thousands of lives and hundreds of Air Force people. This situation is hardly consistent with the general national belief that every individual is important and worthy of protection. In all probability you have had some member of your immediate family, a relative, or a close friend become a part of these statistics. Recall your feelings at the time, multiply this by thousands, and you will readily understand the need for safety. Accidents can and must be prevented, if for no other reason than to eliminate the suffering and hardship they bring. Remember, we must do things on and off the job the safest way we know how. This may not be the most exciting thing to contemplate, but it gives you plenty of time to enjoy some of life’s pleasures.

In this chapter we discuss several facets of basic safety principles and some of the hazards that are ever present in your duty as a maintenance person. We want you to learn these principles and pitfalls—recognizing the fact that they are not all-inclusive on “what to do” and “what not to do.” Learn that a careless moment on the job can hurt you and possibly your buddies and can cost the Air Force. We discuss several principles that apply to safety in general, regardless of what your specific duties are. We discuss specific hazards in your job as an electronics technician and discuss ways to avoid them. We want you to know what to do and how to help anyone injured. Remember, many accidents can be prevented from becoming a catastrophe by doing the right thing promptly and efficiently.

Do more than just learn what we discuss in this chapter; practice and exercise the principles presented and, above all, share your knowledge and experience with your buddies.

3-1. Basic Principles of Safety

When you learn how to operate any piece of Air Force equipment, there are two principal things you learn: first, how to operate the equipment properly and second, how to operate it safely. While you may think of these two things as pretty much the same, there is a difference. Of course, if you don’t operate equipment properly, you may, at the same time, be operating it unsafely because improper operation is often the cause of accidents. You can set the controls properly to operate a piece of electronic gear and yet be careless and get your hand on some live voltage with disastrous results. Think about doing your job in the two ways stated—properly, to get the job done quickly; and accurately and safely, to prevent injury to yourself or to others.

With the above in mind, let’s get to the basic principles of safety that can help us to do a job properly, accurately, and safely. In this section, we discuss the following basic principles of safety:

- Preoperational training.
- Discipline.
- Alertness.
- Safe practices.
- Mental and physical fitness.
- Physical hazards.
- Operating conditions of machines and equipment.
- Operating or working environment.
- Preoperational planning.

051. Define preoperational training, law observance, and law enforcement; state the need for discipline in safety practices; and identify the discipline violation in a hypothetical situation.

Preoperational Training. Preoperational training is necessary to operate any piece of Air Force equipment, whether it is a lathe, powersaw, or an electronic unit—or even a screwdriver. This type of training should not be strange to you, since you received much of it in your formal Air Force school training and have undoubtedly received more of the same after your assignment to your present duty. You must recall your instructor telling you how to use equipment or how to turn on an electronic system. Furthermore, you learned procedures for accomplishing a job by reading technical orders and maintenance documents. In every case, either from an instructor or from a document, safety precautions on the safe procedure of the work were provided. This is preoperational training—learning and understanding how to work accurately and safely before doing the job. Remember, if you aren't sure of a procedure, whether it is a turn-on procedure, maintenance procedure, or any other job, be sure to learn how to do it accurately and safely. Don't take a chance.

In the 32 career area, we are constantly faced with the equipment modification program. Many times units or portions of whole systems are modified to a varying degree. Be sure you read instructions and understand your modified system as well as you do your old system. Too often you hear, "I've always done it this way and haven't had any trouble before." Pretty flimsy excuse if you injure yourself or your buddy or if you damage the equipment.

Discipline. You know from your basic military training and classroom training how important good discipline is, whether it is in close order drill or in a classroom project. It is even more important when there is a threat to your personal safety. We are not saying that your job is extremely hazardous. It is hazardous only when you don't work safely! This is why you must have discipline.

Discipline is simply law observance and law enforcement. Law observance comes from within yourself; law enforcement comes from the outside. Being arrested for speeding is an example of outside discipline. When you observe the speed limits, you exercise self-discipline (law observance). Of course, self-discipline is best. For one thing, it means that you are thinking for yourself. Outside discipline (law enforcement) means that someone else is doing your thinking for you. So, for our purposes, the meaning of good discipline is self-discipline.

Just what does good discipline have to do with you and safety on the job? Perhaps, we can best illustrate this by an example. Let's say that you are performing an alignment procedure on a unit of the radar system, computer, or test equipment. One step of the procedure tells you never to remove the cover from the unit unless you have the high voltage turned off. However, you've done the job so many times that you know you can remove the cover without contacting the high voltage. So you ignore that caution and leave the voltage applied to the unit while removing the cover. Chances are you may get by with this once, maybe several times. However, you are just possibly betting your

life that you can get by with breaking the law of good discipline. You know better; but since "old sarge" isn't there to enforce the law (outside discipline), you think you can get away with shortening the alignment procedure. You may cheat on safety sometimes, but rarely all of the time without getting caught. In our example, once may be too often.

Exercises (051):

1. Define preoperational training.
2. Why is discipline necessary in safety practices?
3. What is meant by law observance and law enforcement?
4. If a technician only follows TO safety procedures when the supervisor is around, this person is prescribing to what form of discipline?

052. List forms of distractions and identify particular ones with causes, effects, or appropriate reactions.

Alertness. Constant alertness is definitely a prime requisite in avoiding accidents. Fundamentally, alertness means paying attention—not just now and then, but all the time. Unless you pay close attention to what you're doing at all times, you undoubtedly end up doing something wrong. Again, you have a situation in which an accident may happen.

The enemies of alertness are external and internal distractions—things that occur outside of you and things that occur inside of you, either mentally or physically. We can't talk about all of the external and internal distractions, but let's look at a few of each.

External distractions. A number of things may happen around you that are distracting. For example, while doing calibration work on test equipment in the lab, you may be startled by a sudden, unusual, or loud noise. If this happens, you must brace yourself and regain your composure and self-control as quickly as possible. Perhaps most important of all is "Don't look around to see what caused the disturbance." This is easier said than done; but if you can do it, you may avoid placing your hand on a high-voltage circuit, into a moving part, etc. As a rule, you cannot control this type of disturbance. The only thing you can do is train yourself to respond to it properly.

Even more serious, perhaps, from the standpoint of safety, is external disturbance that you or your buddies create. The uncontrollable disturbance discussed in the preceding paragraph is bad enough and, as stated, it can cause an accident. It is inexcusable for you or your buddy to create a

disturbance which causes you or someone else to have an accident. This type of external distraction usually takes the form of one of two types: conversation and horseplay.

Conversation is such a very common distractor that you may do it without thinking. Does this mean that when Joe, a fellow worker, says, "Good morning," you should ignore him? The answer is "yes" if you're at a critical point of your work. Get past this critical point, then return his greeting. When you are the greeter, be sure you notice what your fellow worker (Joe) is doing before you greet him. If he is doing a critical job when you first approach him, wait until you know that he can return your greeting safely. Remember, conversation with fellow workers may or may not be a serious distractor. It is usually all right if you keep your eyes on your work as required by the nature of your work, but hazardous if you turn your head to converse.

The second type of external distraction is horseplay. This type is undoubtedly the most risky and the most inexcusable type of distraction. Horseplay has no place on the flight line, dock, shop, barracks, etc.

So far, we've just talked about a few types of external distractions that can cause accidents—there are numerous others—why don't you and your buddies list all you can and then pass the word around?

Internal distractions. There are quite a few kinds of internal distractions that may destroy alertness. These may be either mental or physical. Again, the number of internal distractions is like the number of external distractions, just too many to mention. However, let us talk about a few so that we can see the importance of keeping mentally and physically alert while on duty.

A mental distraction is perhaps most often caused by thinking about personal problems rather than concentrating on what you are doing. This internal distraction causes you to violate the principle of alertness. The reason such a mental distraction is especially hazardous is because it is impossible for most people to concentrate or pay attention to more than one thing at a time. Unless you are a rare exception, you had better forget about personal problems while working. If your personal problems are so great that they interfere with your work, let your supervisor know. He or she may be able to help you solve them. Don't let your personal problems make you cause an accident that damages equipment or hurts somebody. This would create even bigger problems.

Another common mental distraction is daydreaming. This is a particularly dangerous type, since your mind can become completely absorbed in the pleasant thoughts of a daydream. Thereby alertness is almost destroyed. There are very few of us who haven't, at one time or another, been caught "napping" in a daydream by a sudden emergency that we otherwise would have seen. And it isn't necessary to have an emergency—even during a routine job operation, a daydream may sufficiently destroy alertness to cause an accident.

Another distraction whose effects are closely related to daydreaming is boredom. If you happen to be working at a highly repetitive task that fails to stimulate your interest, you may have to combat boredom, which leads to indifference, inattentiveness, and lack of alertness. A similar situation arises when your job has several tasks, some of which are more boring than others. Under these circumstances, you

must guard against working too hastily to complete the dull task to get to the more interesting one. If you work too fast, you may have an accident; obviously, you cannot concentrate on each phase of your tasks as much when you're working fast as when you're working at a normal speed. Remember the old proverb, "Haste makes waste."

The solution to the hazards of daydreaming, thinking about personal problems, or working at a boring task is willpower. There are no simple solutions. You must force yourself to pay attention. No one else can do this for you.

The other kinds of internal distractions are physical. The most prevalent kinds of physical distractions are fatigue, severe pain, and illness. Most of us take care of severe pain and illness, or at least we should. The problem of fatigue cannot always be eliminated. You should recognize it and not let it go too far before you inform your supervisor.

Exercises (052):

1. List two forms of external distractions that could affect safety.
2. What external distraction is the most inexcusable type of distraction?
3. Explain how conversation could affect safety.
4. List two types of internal distractions.
5. What type of internal distraction will cause alertness to be almost destroyed?
6. What is required of an individual to overcome internal distractions?

053. State the major source of job-related injuries, the most common injury, and tell how to prevent this injury.

Safe Practices. The three basic principles of safety—preoperational training, discipline, and alertness—discussed so far help you avoid unsafe practices; however, you should know just what the safe practices on the job are. Let's consider three areas where safe practices are extremely important—operating equipment, using tools, and handling materials.

Preoperational training is one of the best ways to learn to operate equipment and use the handtools associated with your specific job. You must know the operations associated

with your job. Safety precautions on specific alignment and maintenance procedures are usually found in the technical orders that contain the maintenance instructions. Don't minimize the importance of these procedures. An unsafe practice in equipment operation or in the use of handtools is inexcusable, since you have been taught the correct way to operate equipment and use handtools when performing routine maintenance.

The real danger of unsafe practices comes from doing tasks that you do not perform daily. Handling material is a good example. You may not have been taught the body control necessary to insure the safe handling of equipment. You may have forgotten some of the key points of safety involved. According to the National Safety Council, the major sources of injuries on the job are from handling materials. Most of these are back injuries due to improper lifting of heavy objects. With this in mind, study carefully figures 3-1, 3-2, and 3-3.

The bones in your spinal column are stacked like the checkers shown in figure 3-1. The straighter they are, the stronger they are. Hence, the main point to remember when lifting is not to bend your back if you can avoid it. Keep your back as straight as possible. The method is clearly illustrated in figure 3-2. Squat down, get a good grip underneath the load, then lift slowly with your legs. By lifting with your legs, you avoid bending your back and placing a severe strain on your spinal column.

Note the wrong way to lift as shown in figure 3-3. If too much strain is placed on the weak spot, a bad back injury may occur. It is best to lift straight up with the legs to avoid placing such a strain on the weak spot. As indicated earlier, working on the job too hurriedly may also cause an accident.

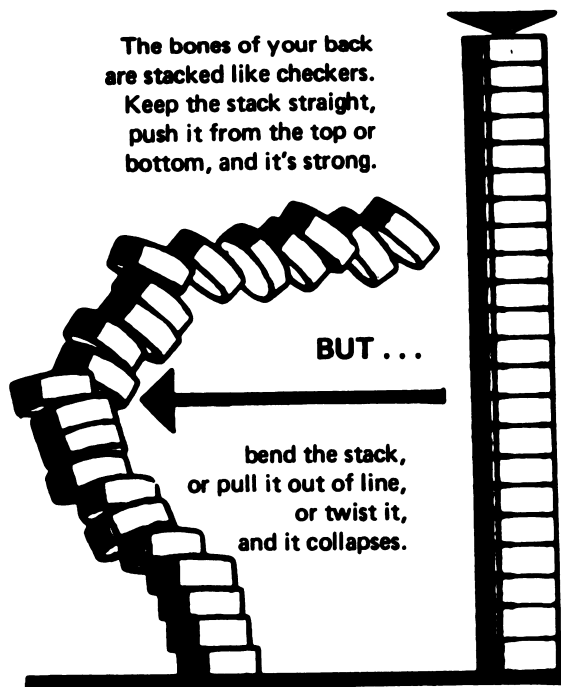
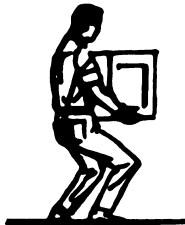
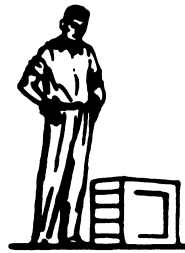

Figure 3-1. How the bones in the spine are like a stack of checkers.



LIFT THIS WAY

1. Check weight and size. A bulky, awkward load can cause more strain than a compact heavier one.
 2. Plant your feet firmly, well apart and squat down.
 3. Watch out for sharp edges. Get a good grip.
 4. Keep your back as straight as you can. Lift slowly (don't jerk) by pushing up with your legs.
 5. Don't twist your body with the load. Shift your feet.
- Load too big, too long, too heavy ?
If in doubt, consult your supervisor.

Figure 3-2. How to lift a heavy load safely.

Instead, work at a moderate, consistent pace. Undue haste can be very costly when handling materials.

Exercises (053):

1. According to the National Safety Council, what are the major sources of injuries on the job?
2. What is the most common job-related injury?
3. When lifting a heavy object, how can you avoid putting a severe strain on your spinal column?

WEAK SPOT



Acute bending is the weak spot in the defense against back strain.

Remember the checkers.

Lift with your legs

Figure 3-3. Every vertebra—a potential weak spot.

054. State the effects of alcohol usage on job performance and cite precautions concerning the safety of the eyes and ears in the working environment.

Mental and Physical Fitness. To maintain mental and physical fitness, you need balanced meals, moderate exercise, and enough sleep. The nature of your work as a specialist or technician normally eliminates lack of exercise as a problem in keeping fit. I'm sure you agree that oftentimes the exercise is even more than moderate! This makes getting enough sleep even more important. The lack of a good night's sleep has been the contributing factor to many serious accidents.

Use of alcohol. Of course you know that it is against regulations to drink alcoholic beverages while on the job. Nevertheless, you may be wondering, "Just how much alcohol does it take to impair your judgment to a dangerous degree?" The answer is "Surprisingly little." Only three bottles of beer or 2 to 3 ounces of whiskey does the trick. You don't have to be drunk. It takes comparatively little alcohol to make it risky for you to operate any kind of mechanical or electrical equipment. Any accident as the result of drinking may affect the performance of your duty. An auto accident would cause you to lose duty time, and the cost of your recovery would be quite high to the Air Force.

There is a common misconception that alcohol is a stimulant. This is not true. Medically, alcohol is classed as a narcotic depressant. This means that it numbs and slows down the operation of the nervous system. If a dangerous situation presents itself while you are in this condition, you cannot react quickly or accurately. Furthermore, alcohol slows down your normal work routine, creating a climate conducive to accidents.

You are familiar with the word "depressed." When you are depressed, you may be in a bad mood and most certainly are not up to par. Remember that this depressing effect lasts longer than just the time you are under the influence of alcohol. The depressing mood is quite often felt the day after, too. There is nothing you can do to throw off these effects of alcohol. You must wait until your natural body processes eliminate them.

Care of the eyes and ears. I'm sure you know the importance of your eyes in your job as well as their importance to your well-being and enjoyment of life. Eyes are one-time issue items; if you want them to last the rest of your life, you must take care of them!

If you need glasses, by all means get them. Surprisingly enough, a great many people need glasses but don't know it. They are accustomed to seeing things slightly blurred. Do you fall into this category? If you do, you are exposing yourself and others to many dangerous situations without knowing it. To be safe and sure, have your eyes examined by an eye specialist. If you must wear glasses, remember that electronics workers must not wear metal rim glasses when working on energized electrical circuits and equipment

If your hearing should become defective, get the proper treatment from an ear specialist. As you well know, flight-line work and, in some cases, shopwork usually requires that you work around high-pitched noises. Use the proper precautions against ear damage when you find yourself in this situation. Your unit should have specified

control procedures and monitoring for personnel safety in situations such as these. If you are supposed to wear earplugs to prevent damage to your ears, wear them.

In all other aspects of physical fitness, keep your general health in as good condition as you can. Get plenty of rest the night before each day's work, eat balanced meals, and otherwise observe the Air Force's physical fitness program as it has been planned for you.

Exercises (054):

1. How can the effect of alcohol on your nervous system affect your performance on the job?
2. How could bad eyesight create a hazardous working condition?
3. Why are ear protectors required when working in high noise level areas?

055. List human elements that are usually present when a hazardous condition is created and state a prerequisite for eliminating hazards.

Physical Hazards. Every job situation has its own peculiar hazards. Some of these can be eliminated by recognizing their existence and taking corrective action. Minimize those which cannot be eliminated by taking precautionary measures. Let's look at a few hazards that apply to anybody who does maintenance work of any kind. You'll note that all of the hazards listed are those that you can do something about. The human element of carelessness is present in every case.

- Not following safety precautions.
- Not using safety devices.
- Operating equipment without proper authority.
- Operating unsafe equipment.
- Working without sufficient experience.
- Working at unsafe speeds.
- Careless housekeeping.
- Indulging in horseplay.
- Assuming unsafe body position while working.
- Failing to warn individuals of possible dangers.
- Fatigue.

If you're wondering why the list isn't called common causes of accidents instead of hazards, you have a good point. In every case, the situation stated can be a cause of an accident. But aren't the biggest hazards on the job usually ourselves and our work habits rather than the equipment? Equipment is not designed to hurt us. It can, but only when we allow or cause it to do so. Thus, if you will just recognize each situation presented as being a hazard, you shouldn't have accidents.

Exercises (055):

1. List six or seven ways in which the human element of carelessness shows itself in creating hazardous conditions.
2. What must you do before you can eliminate hazards?

056. State controllable environmental conditions, the results of a particular control, and the precautions to take in an uncontrollable environmental condition.

Operating or Working Environment. Another basic principle of safety is one that prescribes proper working environment. Your immediate surrounding (environment) can help or hinder you from a safety standpoint. When we talk about environment, we speak of many things; for example, climate, light, heat, noise, equipment, people, etc. For our purposes, working environment is described as the surrounding conditions under which we work. Many of these conditions we can control; others we cannot. Climate or weather conditions create undesirable working environments over which we have little control. Other environmental conditions we *can* control, such as heat, light, space, proper equipment, etc. Let's take a brief look at both the uncontrollable conditions and the controllable conditions.

If you've ever worked on the flight line when the temperature was freezing or considerably below zero, the snow deep, and the wind blowing, you have a pretty good idea of an uncontrollable environmental condition that can be a safety hazard. The same is true when the temperature is 100° F. or higher—so hot that you can't touch the aircraft with the bare hand. Those who have had these experiences know how important environment can be. Since we have to live with these weather conditions, we must be aware of the additional safety hazards that they pose. You know what they are. In the extreme cold, it's either cold hands or bulky gloves, icy conditions underfoot, icy wings and/or ladder steps up to the cockpit, etc. In extremely hot weather, it's probably hands wet with sweat, aircraft surfaces that you can't touch without gloves, blinding heat waves off the aircraft and ramp, and unbearable heat in the cockpit. About the only thing you can do is to slow down your work pace, use extra precautions, and think before doing that otherwise normal task.

Now let's talk about a few environmental conditions that are controllable. One major principle to observe in maintaining a work environment conducive to safety is good housekeeping. Remember, a working environment cluttered with tools is a safety hazard. The layout of your equipment is an important safety factor. You've perhaps noticed in your work areas that almost all equipment has been placed for convenience and ease of work and for elimination of distractions. Remember, the layout is important not only for convenience but also for safety.

Exercises (056):

1. What environmental conditions can we control?
2. What safety precautions must you take when working on the flight line in extremely cold weather?
3. How does good housekeeping affect your working environment?

057. Explain ways in which thorough and efficient preoperational planning aids safety.

Preoperational Planning. The more thoroughly you plan your work, the more likely you are to perform it properly and safely. When you perform a task without first planning for it, you usually make many unnecessary operations, make many mistakes, and use many unsafe actions. Since efficiency and safety are two of your most important considerations as a specialist/mechanic or technician, it is essential that you plan your work thoroughly before you perform it. During this preoperational planning, you organize all operations necessary to complete the work properly, efficiently, and safely.

The most important thing to bear in mind when planning to begin a job is to check pertinent safety instructions. These may concern materials such as protective clothing, machine guards, or the type of equipment you are using. Be sure to study safety instructions carefully, especially if it's a job you're doing for the first time. As you begin work each day, even on comparatively simple tasks that you are familiar with, plan ahead to be sure all pertinent safety principles are observed. If any protective devices are required, have them available.

Remember, for each job you are assigned, use the basic principles of safety. Help make your unit safety conscious. In everything you do, always be careful!

Exercises (057):

1. Why are personnel and equipment safety affected by inadequate or poor preoperational planning?
2. Why should pertinent safety instructions be checked before planning to begin a job?

3-2. Safety Precautions in Maintenance Practices

Most of the hazards that confront you as a repairer of electronic equipment are associated with careless maintenance practices. Now let's discuss some acts of safety that relate to specific job accomplishment. The list that follows certainly is not all-inclusive because of the variety of maintenance jobs that you perform. However, if you observe the safety procedures presented (feel free to add to the list from your experiences), you and those who work with you will benefit. Everyone must be safety conscious. This is one place where one person being careless or not safety minded can louse it up for many.

058. State the possible effects of operating defective equipment, cite examples of hazardous equipment, and state precautions to take before using any equipment.

Operating Condition of Machines and Equipment. If any machine is not in good operating condition, you may have a loss of job efficiency and/or a safety hazard. The same thing can be said about electronic equipment. For example, a synchronizer unit, indicator unit, multimeter, etc., may not have moving parts that can become worn and/or defective, thus causing a safety hazard—but what about those multimeter leads with the broken insulation or the probe tip broken off or that unit with the sharp, ragged edge that someone caused by prying the side panel off with a screwdriver? These conditions can be just as dangerous as the machine that has defective parts, both from electrical shocks and injury possibilities.

Furthermore, speed controls on electrically operated equipment must be in top condition. A defective speed control can keep you from operating a machine or piece of equipment at the proper speed; or it may allow the machine or equipment to run too fast, thus causing an accident. On all electrical and electronic equipment, be sure to check the cables for undue wear or breaks in the insulation. Such conditions, as you know, pose an electrical shock hazard and the possibility of fire.

In any of the aforementioned situations or in any situation involving the proper operating condition of machines and equipment, the prime responsibility lies with you, the operator. Before operating any machine or piece of equipment, become thoroughly familiar with its various parts and become especially familiar with the safety hazards that may develop due to defective or worn parts. Know what hazards to look for and look for them frequently. As noted earlier under "Preoperational Training," a very dangerous condition can develop when you receive a new model, similar equipment, or a modified version of current equipment. In any case, never assume that just because you knew the proper operating procedures and safety involved with the old equipment, you know all about the new equipment. Be sure to find out how the new or modified equipment differs from the one you are used to. Carefully read the technical order or accompanying instruction manual. Remember, new models of similar equipment may have different parts, different controls, and different safety hazards.

Exercises (058):

1. What could possibly occur if you operated a machine with defective parts?
2. Give some examples of defective equipment that could cause a potential safety hazard.
3. What should you do before operating a machine or piece of equipment?

059. State the purpose of the buddy system and explain safety precautions applied under particular working conditions.

General Maintenance Practice Precautions. The following listing and/or brief discussions are commonsense types of safety precautions concerning general items of electrical and electronic maintenance jobs. You should fix these in your mind and then practice them at all times!

Before we get into the actual listing of safety hazards in general electronic maintenance procedures, let's talk a minute about a safety procedure that can be one of utmost importance to you. We call it the buddy system. Some commands have been using this system for a long time; maybe yours is one. You may call yours by a different name or use very similar terminology. This system of safety adopts the policy, "Do not work alone around electronic equipment in the shop or on the line if you can possibly avoid it." If the equipment you are working on is high-voltage equipment, you must use the two-person concept or buddy system. In fact, AFR 127-101, *Ground Accident Prevention Handbook*, directs that there be a safety observer present whenever someone works on high-voltage equipment. Be sure to read AFR 127-101 in regard to this requirement.

The reason that the buddy system of electronic maintenance is so effective shouldn't need much explaining. It is one of those extra-extra safety precautions that we take should someone get into trouble. This trouble might be touching a line circuit and suffering shock, or it might be falling from a stand. In either case the buddy system can help prevent an accident from becoming a fatality by giving immediate aid.

The buddy system has another practical side in addition to the safety it provides. Any time you are working on electronic gear that requires the operation of remotely located switches, it is handy and saves time if you have someone to operate these switches. You may also have occasions when it is not only convenient but saves time if someone is available to operate switches and/or controls located at some distance from the unit on which you are working. In this type of cooperative maintenance, make sure you have your signals straight as to when switches are to be activated.

Use the following safety precautions whether you're in the shop or on the line:

- a. Keep your hands, feet, and clothing as dry as possible when working on electronic gear.
- b. Do not wear metal identification bracelets, wristwatches, metal rim glasses, or rings while working with electrical equipment.
- c. Pull fuses, open circuit breakers, or disconnect the circuits from their power source to protect yourself, the test equipment, and/or the equipment under test.
- d. Do not troubleshoot a circuit with the primary power applied unless absolutely necessary.
- e. Do not use your bare hands to remove hot tubes from their sockets—use asbestos gloves or a tube puller.
- f. Use the correct tool (screwdriver, alignment tools, etc.) for doing the job.
- g. If it becomes necessary to work on equipment with power applied, keep one hand free at all times (behind you or in your pocket) so that you will not complete a circuit path through your body by placing one hand on a voltage source and the other hand on a ground point.
- h. Beware of charged capacitors when making circuit checks.
- i. Be certain that there is no power applied to a circuit when making a continuity or resistance check.
- j. Turn off the power before connecting alligator clips to any circuit.
- k. Carefully inspect the insulation on test leads.
- l. Never use toxic or flammable solvents for cleaning purposes.
- m. Do not take anything for granted when working on electronic equipment.

Exercises (059):

1. From the standpoint of safety, why is the buddy system used?
2. What shop or flight-line safety precaution is necessary to protect yourself, the test equipment, and/or the equipment under test from electrical current?
3. What should you do before connecting alligator clips to any circuit?
4. Why should you put one hand behind you or in your pocket when working on a piece of equipment with power applied?

060. State the possible hazards associated with electrically operated tools and certain techniques for avoiding such hazards.

Safety with Electrical Power Tools. There are several hazards associated with the use of electrically powered tools. Some of these hazards are: electrical shock, cuts, burns, falls, strains, bruises, explosions, and particles in the eye. Observe the following safety precautions when working with electrically powered tools:

- a. Do not attempt to operate a power tool without being properly trained and being fully aware of the safety precautions involved.
- b. See that all cables on power tools are out of the way so that people will not trip over them.
- c. Make sure that all power tools have the proper safety guards.
- d. Check to see that electrical conductors do not have frayed insulation; replace the cord if it is defective.
- e. Make sure all electrical tools and test equipment are properly grounded.
- f. Always wear goggles when using a power tool that causes flying particles.
- g. Always disconnect a power tool after using it—especially at the close of the work shift.

Safety with Soldering Tools. The soldering iron or gun has probably caused more injuries than any other electrical tool used. In most cases, the injuries are not too severe (slight burn, etc.). But any burn can be a source of infection, so do not take it lightly. Poor soldering can cause some real maintenance problems, but let's discuss only the safety involved. You must use the soldering iron or gun properly or you can get burned. The following safety precautions can save you trouble:

- a. Always assume a soldering iron to be hot.
- b. Make sure that the cord and the plug on the iron or gun are in good condition.
- c. Never rest a soldering iron anywhere except on the metal rack provided for that purpose.
- d. Never use excessive solder, because dripping solder may cause burns. Should excess solder collect on the iron or gun, remove it with a rag. Do not swing or shake the gun or iron to remove the excess solder.
- e. Always hold small soldering jobs with pliers or clamp to prevent burns.
- f. Do not hold the rag in your hand when cleaning a soldering gun or iron. Place the cleaning rag on a suitable surface and wipe the hot tip across it.
- g. Do not store a soldering iron before it has cooled.

Exercises (060):

1. What are some of the hazards you may encounter while using electrically powered tools?

2. Why should you wear goggles when using equipment that causes flying particles?

3. How should you clean excess solder off of a soldering iron?

Define "lethal current" and identify safety precautions for working around high voltage with their purposes.

Safety Precautions Around High Voltage. High voltage means different things to different people. To some, high voltage is the 115 volts in the normal home electrical circuit. To others, 300 volts is not considered high. For our purpose, high voltage means any voltage capable of producing a lethal current (over 50 milliamperes). Let us discuss the term "high voltage" and what it should mean to us. AFR 127-101 discusses some procedures you must use when working with high-voltage equipment. Be sure to read about these procedures.

Surface resistance to electrical current varies with individuals and depends on skin thickness and body conditions such as:

- Dry skin—100,000–600,000 ohms.
- Wet skin—1,000 ohms.
- Internal body: hand-to-foot—400–600 ohms; ear-to-ear—100 ohms.

Keep the following precautions in mind:

- a. Do not work with high-voltage equipment by yourself; have another person (safety observer), preferably one qualified in first aid for electrical shock, present at all times.
- b. Do not rely upon insulation as complete protection against electrical shock.
- c. Keep your feet clear of objects on the floor—stumbling into high voltage is a common problem.
- d. Use a shorting rod to discharge all high-voltage capacitors before working on a circuit. Use rubber gloves when called for in the maintenance procedure. Make sure the gloves are in good condition, and test for holes and insulation breakdown.
- e. Do not change electron tubes or make adjustments inside equipment when the high-voltage supply is turned on.
- f. Make certain that the equipment is properly grounded. Ground all test equipment to the equipment under test.

We know that the preceding list of safety precautions is not complete. Certainly, on specific maintenance procedures you may have several specific precautions that must be exercised. The important thing to remember is to exercise those we have listed as well as any special precautions required for specific maintenance functions.

Throughout this section we have talked about ways of preventing accidents. But what do you do if there is an accident? Do you know enough first aid to prevent the accident from becoming a fatality? You should know enough about certain first-aid procedures that you can help until qualified medical attention arrives.

Exercises (061):

1. What is considered a lethal amount of current?

2. What qualification should your safety observer possess?

3. Why is it especially important that the shop floor be free of objects when personnel are working around high voltages?

4. What should be done before working on a circuit that involves high-voltage capacitors?

5. What precaution is necessary when testing equipment with high-voltage test sets?

062. Given conditions relating to operating ground power equipment, state the precautions that should be exercised.

Safety Ground Ground Power Equipment. The following information from AFR 127-101 provides guidance and safety instructions for operating ground power and auxiliary power equipment. It is not within the scope of this course to provide detailed instructions on the use of this equipment because of the various types and/or models of equipment involved. You should know the correct, safe procedures for operating any ground power equipment. The following requirements and reasons for safe operation apply to all ground power and auxiliary power equipment:

- a. For the protection of equipment and personnel, help assure that only fully qualified and authorized persons start and operate ground power and auxiliary power units.
- b. Become thoroughly familiar with the handbook of operating instructions for the equipment.
- c. Know the emergency shutdown procedures, other precautionary measures, and the use of fire extinguishers.
- d. Review the maintenance and inspection records attached to the unit.
- e. Inspect the equipment for leaks, damage, or malfunction before operation.
- f. Never use power units within 50 feet of fuel servicing operations or flammable spillages.
- g. Follow applicable directives when inspecting and maintaining ground power units.

We know that the preceding lists of safety precautions are not complete. Certainly, on specific maintenance procedures you may have several additional precautions that must be exercised. The important thing to remember is to exercise

those we have listed, as well as any special precautions required for specific maintenance functions.

Exercises (062):

1. For the protection of equipment and personnel, who should operate ground power and auxiliary power units?
2. State the precaution when operating a power unit during fueling or defueling operations.

063. Identify precautions that must be taken around compressed gases.

Safety Precautions with Compressed Gases. In this lesson, identification and handling precautions relating to compressed gases will be discussed. Compressed/pressure systems contain gases or liquids under pressure and, sometimes, extreme temperatures. The degree of hazard in pressure systems is proportional to the amount of energy stored, not the amount of pressure present. Therefore, low-pressure, high-volume systems can be as hazardous as high-pressure systems.

Many gases, in different forms, are used in Air Force operations. These gases may exist as a solid, liquid, or gas; the state is determined by temperature and pressure. Both the flammable and nonflammable gases have a wide variety of uses. They are used in welding operations, in life-support systems, in pressure tests, as cooling agents, to pressurize system components, as propellants, etc. Because of their compressibility, large quantities can be stored under pressure in relatively small containers.

Compressed gases are stored in high-quality steel cylinders. These cylinders are similar for all common gases. Each cylinder is fitted with a valve with a safety cap containing fusible safety plugs to release the compressed gas when extreme pressures build up or temperatures reach the danger point. The following information from TO 42B5-1-2, *Use, Handling, and Maintenance Instructions for Storage Type Gas Cylinders*, provides the general rules and precautions for safe handling of cylinders containing compressed gases:

- a. Gases should be referred to by their proper names rather than as "air" or "gas." All Air Force compressed gas cylinders have the name of the gas stenciled parallel to the longitudinal axis on diametrically opposite sides.
- b. Do not tamper with the safety devices in the cylinder valves.
- c. Regulators, pressure gages, hoses, and other fittings must not be used interchangeably with similar equipment used with other gases.
- d. Be particularly careful that the threads on regulators or unions are the same as those on the valve being used. If the fittings are hard to turn, they must not be forced. Make sure that the fittings have the same thread type and have the same number of threads per inch to produce a satisfactory seal.

e. Do not use compressed gas from the cylinder without reducing the pressure through a regulator intended for this purpose. Do not reduce the pressure by throttling through the cylinder valve. (NOTE: An exception to this rule is the filling of fire extinguishers with carbon dioxide and the transfer of other gases in the liquid state at normal temperatures.)

f. Before connecting the coupling or pressure regulator to the cylinder valve, open the valve approximately one-fourth turn and close it immediately. This clears the valve of dust, dirt, or moisture elements that could enter the regulator. Do not perform this operation near any possible source of ignition.

g. After attaching the pressure regulator to the cylinder valve, check to be sure that the adjusting screw on the regulator is released before you open the cylinder valve.

h. If you have difficulty opening a valve, point the valve opening away from your body and use greater force. Valves fitted with handwheels should be operated by hand only. Valves that require the use of a wrench should be operated only with a properly fitting wrench or key. If a wrench or key is used, it must be kept ready for instant use while gas is issuing from the cylinder. (NOTE: Wrenches or hammers must not be used to open or close valves equipped with handwheels. Such tools can damage the valve seat, resulting in the escape of the gas.)

i. Always open cylinder valves slowly to prevent a sudden discharge of gas into the pressure regulator.

j. Before you remove a pressure regulator from the cylinder, be sure to close the cylinder valve and release all gas from the regulator.

k. Open the cylinder valve fully but slowly each time gas is used from the cylinder. (CAUTION: Acetylene valves are an exception to this rule. Acetylene valves should never be opened more than 1½ turns.)

l. If a valve leaks when it is opened, immediately close the valve. If the leak does not stop, move the cylinder out of doors and expel the gas to the atmosphere; tag the cylinder as repairable after it is empty. While the cylinder is being emptied, keep all unnecessary personnel and all sources of ignition away. If a leak develops in the safety device, move the cylinder out of doors and open the valve to allow the gas to escape.

m. Never attempt to stop a leak between the cylinder and regulator by tightening the adjusting nut unless you have closed the cylinder valve first and allowed time for the gas to escape.

n. Always close the cylinder valve when the gas is not in use. Replace the valve protection caps, using extreme care not to damage the outlet threads.

o. Always assume that compressed gas cylinders are full, and handle the cylinder with corresponding care at all times to prevent a possible accident. Do not lift a cylinder by grasping the valve or the valve protection cap.

Special Precautions for Handling Helium and Nitrogen. Helium and nitrogen gases are *odorless, tasteless, colorless, and chemically inert*. They are neither corrosive, explosive, nor flammable. They do not support combustion, are not toxic nor irritating, and do not combine with other materials to form nitrides. However, they can dilute atmospheric oxygen to unsafe levels and create an

asphyxiation danger. Helium and nitrogen under high pressure, like other compressed gases, present a serious hazard to personnel because of the very large amounts of energy stored in these compressed gases.

In addition to the instructions and precautions contained in the appropriate equipment technical orders, the following information from AFR 127-101 provides guidance and safety instructions for handling gaseous helium and nitrogen:

a. Always wear adequate eye protection (glasses or face shields).

b. Never enter an area where there is a high concentration of gaseous helium or nitrogen without using an auxiliary source of air for breathing.

c. At least two persons should be present when a pressurizing system is being operated.

d. Store cylinders where they are protected from weather and where they can be adequately restrained to prevent unwanted movement.

e. Storage facilities should have adequate ventilation, because these gases are odorless and colorless and can asphyxiate without prior warning.

Liquid nitrogen, like gaseous nitrogen, is colorless, odorless, nonflammable, nontoxic, and chemically inactive. It is colder than liquid oxygen, with a boiling point of -320° F., and has an extremely high vapor pressure. Under increased pressure, nitrogen remains a liquid up to its critical temperature of -233° F. When nitrogen is at or above its critical temperature, no amount of applied pressure can keep it in the liquid state.

Liquid nitrogen is dangerous because of its low temperature; bodily contact results in severe frostbite. If confined, liquid nitrogen evaporates and builds up tremendous pressure. The vapor from liquid nitrogen displaces the air in inclosed or unventilated spaces, causing asphyxiation. Thus, adequate ventilation (using outside air) should be provided to insure against an oxygen-deficient atmosphere where quantities of nitrogen vapor might be regularly released in a shop or handling area.

When you are servicing equipment with liquid nitrogen, you must wear knitted, napped, cotton-lined, asbestos gloves with a gauntlet cuff. Also, you must wear approved acid-type goggles or a face shield. Wear an apron when handling liquid nitrogen in an open system.

Exercises (063):

1. What TO provides the general rules and precautions for safe handling of cylinders containing compressed gases?

2. How is the type of gas identified in Air Force compressed gas cylinders?

3. What precaution should you take when screwing regulators on unions onto compressed gas cylinder valves?

4. What is probably wrong and what will be the results of forcing fittings that are hard to turn?

5. What measure is taken to protect cylinder valve threads when cylinders of compressed gas are not in use?

6. Why would you crack the cylinder valve before connecting the pressure regulator to the cylinder valve?

7. What unsatisfactory condition may result if wrenches and hammers are used to open or close valves equipped with handwheels?

8. Why would you open the cylinder valve slowly when discharging compressed gas into a pressure regulator?

9. Why are special precautions necessary when handling helium or nitrogen?

10. What danger to personnel exists because of the low temperature property of liquid nitrogen?

11. What Air Force document contains the instructions for safe handling of gaseous helium and nitrogen?

12. How many personnel should be present when a nitrogen or helium pressurization system is being operated?

3-3. Radiation

In this section we identify the different types of nuclear radiation and their effects and describe the protective devices and precautions required. We also look at some sources and effects of radiofrequency radiation and some precautions relating to this radiation.

064. Identify radiation types, methods of measurement, detection devices, and placards; and identify the particular types of radiation with their effects and hazards.

Nuclear Radiation. The final form of destruction resulting from atomic explosion or exposure to contaminated equipment is nuclear radiation. This radiation consists of alpha, beta, and gamma rays.

Alpha radiation. Alpha radiation can be stopped by almost any barrier, including an inch or two of air; and it becomes a hazard only if the material is taken into the body by breathing, by eating or drinking contaminated food, or by broken skin surfaces.

Beta radiation. Beta radiation has a range of a few feet in air and has very little penetrating power. However, beta radiation may inflict severe burns on the unprotected skin as well as internal damage if ingested into the body. It can be stopped by such barriers as ordinary clothing; however, protective clothing should be used when working in a contaminated area. Beta, like alpha emitters, can damage tissues when taken internally. Protective clothing and respirators are the only protection needed for either alpha or beta rays.

Gamma radiation. Gamma radiation can never be completely absorbed by any barrier. For this reason, it is the most deadly hazard to consider during any decontamination procedure. The intensity of the radiation is monitored by trained personnel. This intensity is expressed as a quantity of radiation per unit of time. The quantity unit of measure is the *roentgen* and the time unit is the *hour*; thus, intensity is expressed in roentgens per hour (R/h).

Protective Devices and Precautions. When working on or near contaminated equipment, you will be under the supervision of medical personnel. You are required to wear a film badge or dosimeter so that the amount of radiation (dosage) you receive can be measured. This is put into your medical records. You will not be allowed to collect too large a dosage. After working on contaminated equipment, immediately take a shower. Then check to see that you have removed all the radiation particles. If you are free of radiation, dress in clean, contamination-free clothing. Waste materials from cleaning contaminated equipment are disposed of by burial. This is done away from any maintenance activity.

Although nuclear radiation is the least likely hazard met on the flight line, still it may exist in the event of an accident while handling a nuclear crash. It may also exist if an aircraft carrying a nuclear weapon should crash. One of our planes may fly through a contaminated zone and, upon its return, need repair.

Radiation is invisible. We have only one way to show its presence and that is by placing radiation placards in the area. Study the symbol in figure 3-4. Learn its shape and colors (magenta—reddish purple—on a yellow background). It may save your life.

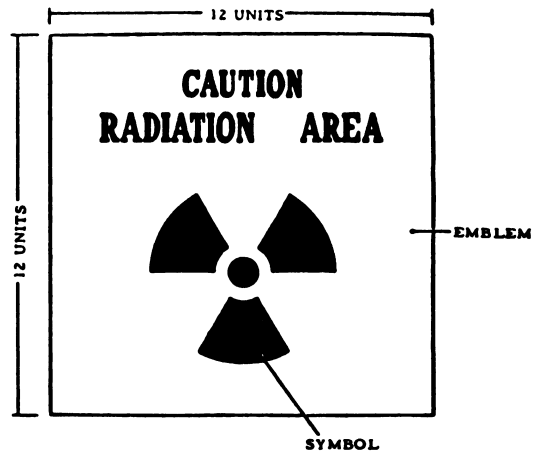

THE PROPORTIONS OF THIS EMBLEM ARE BASED UPON THE VALUE OF ONE UNIT.
 ONE UNIT EQUALS THE DIAMETER OF THE CENTER CIRCLE OF THE SYMBOL.
 THE EMBLEM IS TWELVE UNITS HIGH BY TWELVE UNITS WIDE. THE SYMBOL IS CENTERED IN THE LOWER TWO-THIRDS OF THE EMBLEM.
 THE SYMBOL IS CONSTRUCTED OF THREE CONCENTRIC CIRCLES, THE OUTER CIRCLES BEING DIVIDED INTO SIX SECTORS, ALTERNATE SECTORS COLORED.
 THE CIRCLES HAVE RADII IN THE PROPORTIONS OF ONE TO ONE AND ONE-HALF AND ONE TO FIVE.
 THE LETTERS ARE OF BLOCK TYPE, ONE UNIT HIGH, AND CENTERED IN THE UPPER ONE-THIRD OF THE EMBLEM.
 BACKGROUND COLOR OF THE EMBLEM IS YELLOW.
 SYMBOL COLOR IS MAGENTA.
 LETTERS ARE BLACK

Figure 3-4. Standard radiation hazard warning emblem.

Exercises (064):

1. List the destructive forces of nuclear radiation.
2. Identify the radioactive force that can be stopped with an inch of air.
3. Which radioactive force can be stopped by ordinary clothing?
4. Which radioactive force is considered the most deadly?
5. How is the intensity of radiation expressed?

6. When are alpha and beta radiation particles considered hazardous?
7. What type device is required to be worn when working near contaminated equipment?
8. List the conditions where nuclear radiation could be encountered on the flight line.
9. Describe the appearance of a radiation placard.

065. List the sources and effects of radiofrequency (RF) radiation and state precautions to be taken.

Radiofrequency Radiation. We now mention dangers that are beyond our ability to see or hear. These are called radiofrequency transmissions. "Electromagnetic radiation" is another name applied to this hazard. This radiation is given off by high-frequency radio transmitters, radar, and electronic countermeasure devices. The energy radiated by the transmitter antennas can cause flashbulbs to ignite and steel wool to burn.

It can cause burns beneath the skin and cataracts over the eyes. The presence of this energy may not be apparent. The injuries may occur before any pain is felt. When electromagnetic energy is absorbed in the tissues of the body, heat is produced. If the heat cannot be dissipated as fast as it is produced, the internal temperature of the body will rise. Internal organs are not cooled by an abundant flow of blood. Therefore, these organs can be easily damaged by heat from excessive exposure to radiation.

To avoid this danger, don't stand in the beam of a nearby radar antenna; you can't tell that your internal organs are being heated, and serious damage can be done before you know it. Wherever possible, in a maintenance situation, all personnel should avoid the area of radiating power from radar antennas.

If it is possible to radiate the power into space or couple it into a dummy load, then a radiation absorption screen should be used. Radiation hazards depend upon a great many variables, such as time of exposure, strength of emission, weather, and the number of units operating in the area. Commonsense, good judgment, and experience must be used to evaluate these variables.

Exercises (065):

1. List three sources of RF radiation.

2. What is the principal effect of RF radiation on the human body and vital organs?
3. What basic precaution can you take to avoid exposure to RF radiation?
4. What protective device may be used for partial protection against RF radiation?

3-4. Responsibilities Associated with Radioactive Sources

Radiac standards contain a specific quantity of radioactive material and are designed as a standard source of radiation for use in the calibration and certification of radiac equipment. In view of their peculiarities, take all precautions to eliminate any condition detrimental to the accuracy of the standard and to preclude contamination or excessive and unnecessary radiation exposure of personnel during handling of these standards. You should also keep in mind the nature and severity of radiation hazards.

The inherent hazards of radioactive materials have led to the development and enforcement of rigid controls in the use of these materials. The 3- and 5-level PME technicians normally have no responsibilities in the radiac/radioisotope area. But you must be aware of the precautions and safety factors associated with these sources. The three following paragraphs are an introduction to your radiac safety awareness.

066. State selected precautions and procedures observed in storage, handling, and use of cesium-137 source and shield container.

Storage, Handling, and Use of the Cesium-137 Source. The hazards of improper storage, handling, and use of the cesium-137 source cannot be overstressed. While the quantity of cesium-137 is not excessive, take proper care at all times to insure minimum exposure of personnel in the storage or use area to ionizing radiation. The precautions and procedures are:

- a. USAF radioactive material permit. The actual use of the source must be as authorized in a valid USAF radioactive material permit.
- b. Source protection. Protect the sample against exposure to weather and corrosive agents.
- c. Source storage and utilization. Place the source in such a location as to present the least possible exposure to personnel.
- d. Source security. Keep the shield container locked at all times when not in actual use.
- e. Film dosimeters. Wear film dosimeters at all times when working with or near the exposed source.

f. Direct exposure. Avoid exposure to the direct beam of the source.

g. Source removal. Do not remove the cesium-137 source from the shield container under any circumstances.

h. Calibration operations. Perform calibrations as rapidly as practical to minimize exposure.

i. Leak test. Make a leak test of the sample at the time of receipt and at intervals not to exceed 6 months thereafter.

j. Smoking and eating. Do not smoke or eat in any area where a radiation ingestion hazard exists.

k. Personal hygiene practices. When working with a source, observe all protective personal hygiene practices, which include wearing appropriate clothing and washing the hands and face before eating and smoking.

Observance of the practices and procedures minimizes the exposure of personnel in the radiation area to ionizing radiation.

Exercises (066):

1. What precaution must be observed regarding cesium-137 source security?
2. Under what circumstances may the cesium-137 source be removed from the shield container?
3. When should film dosimeter be worn?

067. State construction characteristics of the cesium-137 source shield container.

Cesium-137 Source Shield Containers. The cesium-137 source is used in the PMEL to calibrate gamma and beta-gamma radiation detecting instruments. Beta and gamma radiations travel great distances in air and accordingly the shielding of a beta-gamma source (cesium-137) must be adequate to preclude excessive personnel exposures to ionizing radiation.

The shield container for cesium-137 is made of lead and is inclosed in steel. The container is approximately 8 inches long and 6 inches in diameter. Square plates on the ends allow the container to be placed on its side for use when calibrating detection instruments. The container has a well, 1 1/2 in diameter, of sufficient depth to allow the cesium source to be centered in the container. The source is positively attached to the bottom of the well. A plug, which is kept in place when the source is not in use, is also made of lead encased in steel. Provision has been made for the use of a security lock. A metal plate attached to the container is inscribed with the following data:

- Isotope chemical symbol.
- Activity in millicuries.
- Calibration date.
- Serial number.

- Intensity in milliroentgens per hour in (mr/h) at 1 meter at the time of calibration.

In addition, the container is also marked with the radiation caution symbol and the words "Caution Radioactive Material."

Exercises (067):

1. What type material is used in the construction of the cesium-137 source shield container?
2. What type of data is found on the surface of the shield container?

068. State responsibilities regarding the obtaining, handling, and controlling of radioactive sources.

PMEL Responsibilities. The integration of radiac equipment into the USAF calibration program established a requirement for PMELs to have appropriate radioactive sources. The mere requirement to use a radioactive source does not mean that a source may be requisitioned by a PMEL. The source may be requisitioned only after receiving approval from the USAF Radioisotope Committee. Procedures have been established for obtaining, controlling, and handling radioactive materials and are found in various Air Force regulations and technical orders. A partial listing of these procedures would include:

- a. Obtain proper authorization for maintaining source in PMEL from the USAF Radioisotope Committee.
- b. Observe established radiation protection measures.
- c. Adequately document all maintenance actions.
- d. Insure personnel are trained in use of radioactive materials.
- e. Insure radiation areas and materials are properly identified.

As we have already stated, the authorization to maintain a source comes from the USAF Radioisotope Committee. Once the source is on hand, be sure to observe all precautionary procedures. Designate areas for the storage and use of radioactive sources. Do not store any other items in a storage area used for radioactive sources. Do not store any other items in a storage area used for a radioactive source. Likewise, make sure the area where the source is used is cleared of unauthorized personnel. Mark the areas where radiation may be encountered as well as the radiation sources. Use the standard radiation symbol (fig. 3-4) to reflect the existence of a radiation hazard. This symbol is used on a number of AFTO warning forms such as those used to indicate radioactive material (fig. 3-5,A), designated radioactive area (fig. 3-5,B) and ingestion hazard (fig. 3-5,C). Still other forms are used to indicate areas of high radiation, airborne radioactivity, and radioactive material storage. The forms come in specific sizes; however, if

APPROVAL OF BUDGET BUREAU NOT REQUIRED

CAUTION RADIOACTIVE MATERIAL



CHEMICAL SYMBOL
AND ATOMIC WEIGHT

QUANTITY IN MILLICURIES

DATE

AFTO 3271 98 PREVIOUS EDITIONS OF THIS FORM ARE OBSOLETE

CAUTION RADIOACTIVE MATERIAL

ISOTOPE
AMOUNT
DATE



A. RADIOACTIVE MATERIAL WARNING LABELS

APPROVAL OF BUDGET BUREAU NOT REQUIRED

CAUTION RADIATION AREA



AUTHORIZED ENTRANCE ONLY
CONTACT
RADIOLOGICAL MONITOR OR SUPERVISOR IN CHARGE

AFTO 3272 98 PREVIOUS EDITIONS OF THIS FORM ARE OBSOLETE

B. RADIATION AREA WARNING PLACARD



RADIATION HAZARD

NO SMOKING, EATING OR DRINKING IN THIS AREA





AFTO 3273 98 PREVIOUS EDITIONS OF THIS FORM ARE OBSOLETE



C. RADIATION INGESTION HAZARD PLACARD

Figure 3-5. Warning forms.

different sizes are required, they may be locally fabricated according to specifications shown in figure 3-4.

The last area of our discussion deals with training. One of the prerequisites to obtaining approval for use of radioactive sources is the availability of trained personnel. Trained personnel are listed on the application forwarded to the USAF Radioisotope Committee. Radiological training is mandatory for personnel responsible for the use of

radioactive materials. This training is presently being conducted at Lowry AFB in a course on radiac instrument calibration and repair.

Exercise (068):

1. State responsibilities of the PMEL for obtaining, handling, and controlling radioactive sources.

Air Force Publications

THIS CHAPTER contains information required for your upgrade training in the area of Air Force publications. Every aspect of your progression to the 5 level of your AFS is directed and controlled by a multitude of Air Force regulations, manuals, technical orders, and administrative publications which are directive in nature.

The information in this chapter will help you acquire the knowledge required for 5-level performance of the tasks listed in your Specialty Training Standard (STS). These tasks require the use of technical orders, commercial publications, and forms.

4-1. Administrative Publications

Although you are not being trained for the Administrative Career Field, you are required to understand some of the principles of administration. In this section, you will learn about administrative publications which you can study to increase your proficiency as a technician. Let's start with the study of indexes for the Air Force regulations, manuals, pamphlets, visual aids, and training materials that are available for administrative purposes.

069. Identify the use of "base numbers" with purpose and prescribing regulation; and, for types of publications, specify the base number.

Numbering System for Administrative Publications.

The first thing to remember in using administrative indexes is that the numbers assigned to these publications are not designated haphazardly. AFR 5-4, *Publications Numbering Systems*, prescribes the base numbers for controlling and identifying all publications, whether they are regulations, letters, pamphlets, manuals, or any of the other types of this group. The base number 5 (as found in AFR 5-4) refers to the publications that are included in the group known as publications management. Therefore, a publication that contains information concerning the management of publications begins with "-5." The groups of publications with which you should be familiar have the following base numbers:

Base No.	Subject Area
0	Indexes
1	Aerospace Doctrine
5	Publications Management
21	Organization and Mission—Departmental
23	Organization and Mission—Field
35	Military Personnel
39	Enlisted Personnel
50	Training
52	Technical Training
67	Supply

Base No.	Subject Area
72	Federal Supply Cataloging
74	Quality and Reliability Assurance
127	Safety
136	Armament
144	Fuels, Propellants and Chemicals
205	Security
207	Aerospace Systems Security
900	Awards, Ceremonies, and Honors

Although these groups may not include all the publications that affect your job, most of the directives and regulations that influence your career are in one or more of these groups. From this understanding of the basic numbering system and how it affects you individually, it is apparent that AFR 5-4 is the key that unlocks the door to a complete understanding of publications.

All Air Force activities must follow the system established in AFR 5-4 when they publish their own directives, supplements, and regulations. These directives, supplements, and regulations are usually written to amplify a higher headquarters directive. Thus, it is entirely possible that, in your unit's limited files, the original or basic publication is supplemented two or more times. Generally, these supplements are filed behind the basic document in which certain paragraphs carry notations to see local and command supplements. The supplement carries the same title and subtitle as the basic document.

Exercises (069):

- Briefly explain the purpose of "base" numbers associated with the identification and control of administrative publications.
- Identify the Air Force regulation that prescribes the base numbers for controlling and identifying administrative publications.
- Identify the "base" numbers for training, supply, and publications management.

4. When directives, supplements, and local regulations are prepared, what document must the preparing agency follow?

070. Identify administrative publications indexes with their contents.

The description of each index should include the index title and a brief statement of purpose, types of listings, and an indication of whether the listings are alphabetical or numerical.

Contents of Administrative Publications Indexes. The information in the paragraphs which follow identify some of the indexes you will probably use to locate specific information. These indexes are numerically listed in AFR 0-1, *Guide to Indexes, Catalogs, and Lists of Departmental Publications*: This regulation includes a description of the contents of each index listed. In addition to the identifying numbers and statements concerning the use of indexes, catalogs, and departmental publications, AFR 0-1 provides information on their revision cycles and distribution (or source of availability) and identifies the office of primary responsibility (OPR).

AFR 0-2, which is identified as the *Numerical Index of Standard and Recurring Air Force Publications*, also contains an alphabetical listing of administrative publications grouped by the subject areas and base numbers (series numbers) contained in AFR 5-4. The publications listed in AFR 0-2 are divided into four major groups: *Recurring Periodicals, Visual Aids, Regulations, Manuals, Pamphlets, and Obsolete Publications*. The example that follows includes extracts from AFR 0-2 to show how these publications are grouped and listed.

Example: (AFR 0-2)

Numerical Index of Standard and Recurring Air Force Publications

Recurring Periodicals

No.	Issue/Yr	Title	OPR	Distr
11-1	24	TIG Brief	IG	F
35-4	6	Persfacts	MPC/MPCM	F
190-1	26	Air Force Policy	SINC/II	F

Letter for Commanders

Visual Aids

No.	Date	Title	OPR	Distr
39-1	30 Air 80	Airman Classification	MPCR	F
900-3	1973	Structure Chart Armed Forces Decorations and Awards	SPIA	F

Regulations, Manuals, and Pamphlets

No.	Date	Title	OPR	Distr
-----	------	-------	-----	-------

0—Indexes

R 0-1	1 Sep 74	Guide to Indexes, Catalogs, and Lists of Departmental Publications	DAPS	F
-------	----------	---	------	---

R 0-2	1 Apr 80	Numerical Index of Standard and Recurring Air Force Publications	DAPDQ	F
R 0-8	1 Jun 80	Numerical Index of Specialty Training Standards	MPC/MPPT	F
R 0-10	1 Apr 80	Management Control and Authorization Program of Allowance Source Codes for USAF Activities	LEYSP	F

5—Publications Management

INo.	Date	Title	OPR	Distr
R 5-1	1 Jun 78	Air Force Publications Management Program	DAPS	F
R 5-4	15 Feb 74	Publications Numbering Systems	DAPS	F

8—Special Publications Systems

R 8-13	27 Jun 80	Air Force Specialty Training Standards	MPPTS	F
--------	-----------	---	-------	---

Obsolete Publications (S = Superseded)

No.	Date	Status
P35-4	Sep 69	S/S by P35-19, Mar 80
R66-35	6 Nov 72	Rescinded
M300-6	1 Sep 75	S/S by R300-6, 11 Jul 80

The extract from AFR 0-2 in the preceding example is included so that you will know the numbers of the indexes which contain listings of administrative publications; the types and classifications of indexed; and the method used to indicate the current dates of the publications listed. Most of the symbols in the extracts are self-explanatory, that is, R (regulation), M (manual), P (pamphlet), and S (superseded). Distribution F indicates that the distribution (need for the publication and the quantity issued) is determined locally based on a functional statement published in the Publications Bulletins. Functional statements are maintained on an AF Form 574, Distribution Record, by the publishing distribution office (PDO) for reference until the publications are rescinded or superseded.

Exercises (070):

1. If you are in doubt as to what index to use for administrative publications, what Air Force regulation can you consult as a guide?
2. What administrative publication index should you consult to determine the status of a Specialty Training Standard used in your OJT section?

3. Match each regulation in column A with the appropriate title listed in column B.

Column A

- ___ (1) AFR 0-1.
 ___ (2) AFR 0-2.
 ___ (3) AFR 0-8.
 ___ (4) AFR 0-10.

Column B

- a. *Numerical Index of Specialty Training Standards.*
 b. *Management Control and Authorization Program of Allowance Source Codes for USAF Activities.*
 c. *Guide to Indexes, Catalogs, and Lists of Departmental Publications.*
 d. *Numerical Index of Standard and Recurring Air Force Publications.*

4. R 0-8 is listed in the _____ portion of AFR _____.

5. TIG Brief No. 11-1 is listed under the _____ portion of AFR _____.

6. Information concerning superseded or rescinded publications is located in the _____ portion of AFR 0-2.

4-2. Air Force Regulatory and Procedural Publications

Documents of a regulatory nature and those which expand and provide details in support of Air Force regulations must be included in your administrative publications file. Let's study the titles of a few of these publications. As you study the titles and the accompanying descriptions, try to recognize those publications which have already affected your career progression.

071. When presented brief descriptions of required information, indicate the appropriate source document or type of document described.

Manuals. As a type of administrative publication, manuals normally contain permanent and detailed instructions, procedures, and techniques that tell personnel how to perform their assigned duties. These manuals are issued to support specific training requirements and to disseminate study and reference materials.

The contents of other manuals may be general and may deal with principles of doctrine, such as AFM 1-1, *United States Air Force Basic Doctrine*. This Air Force manual is one of several manuals listed in AFR 0-2 that describe the operations related to the subject area of aerospace doctrine.

Individual commands are given the authority to prepare manuals, as the need arises, in areas where they do not

duplicate publications already printed. An example is ATCM (Air Training Command Manual) 52-9, *Guide for Special Training*. The subject area, which is indicated by its base number (52), is technical training. If this manual became useful to two or more commands, it could very well be changed to an Air Force manual.

Pamphlets. As a type of administrative publication, pamphlets fulfill a certain need in keeping you well informed. Pamphlets are usually issued as brochures or booklets, and they may be written in an informal style. Like the manuals discussed before, pamphlets are permanent publications. An example would be AFP 50-56, *USAF Aerobics Physical Fitness Program (Male)*. You should review this pamphlet because it requires that once each year your weight be checked and that you pass a physical fitness test.

Visual Aids. Although visual aids as a type of publication do not have the widespread distribution of regulations, they serve a useful purpose, especially when they are issued in conjunction with planned operations or programs. Visual aids are available in the form of charts, posters, and graphic illustrations and may be displayed until rescinded.

Like other standard publications, visual aids are listed in AFR 0-2 within their subject areas and by their base and secondary numbers. Typical visual aids listed in the -2 index are as follows:

- a. AFVA 75-7, *Transportation Visual Aid.*
 b. AFVA 161-1, *Air Force Visual Aid—Wind Chill Chart.*

If you have been using visual aids for some time in making presentations or orientations, you should check the Visual Aids section of AFR 0-2 to see whether your visual aids are still current.

Training Materials. Whether you serve as a manager or a supervisor of other personnel, the USAF publications system will serve you as a rich source of training material. As a skilled specialist or mechanic, you must seek out new technical information in your career field to strengthen your professional training.

In an organization as large as the USAF, many kinds of training are available. AFR 0-2 shows one document (AFM 50-5, *USAF Formal Schools Catalog*) that lists all of the professional, flying, and technical training available to military and civilian personnel of the Air Force.

This catalog is a ready reference to all formal or resident schools, their locations, courses taught, and student prerequisites. Off-duty training courses, such as the one you are presently studying, are also listed. Most of the training conducted in the Air Force is the technical training taught in formal schools, in the field, and on the job. Technical training enables an individual to perform tasks contained in an Air Force specialty (AFS) description. When you become a manager of a section or shop, you may have to be familiar with more than one Air Force specialty to run your activity effectively. For this reason, you should make a study of the available training materials, such as manuals, pamphlets, and visual aids, that can be used to instruct personnel either on the job or during off-duty hours. A list of these publications is found in AFR 0-2, particularly under the following subject areas:

Base No.	Subject Area
50	Training
52	Technical Training
66	Equipment Maintenance
67	Supply
127	Safety
205	Security

Recurring Publications. Recurring publications are nondirective and highly informative publications which the Air Force issues at stated or regular intervals. Some Air Force recurring publications are like the "slick" commercial periodicals that are directed to specific professions and trades. Such commercial periodicals contain current technical and safety information. New developments within the profession, as well as new equipment, are discussed in detail. Subscribers to these periodicals are, of course, experienced professionals or highly skilled technicians who readily understand the technical articles contained in such periodicals.

Each of the services—Army, Navy, and Air Force—has official journals that are mediums for the exchange of ideas and information among its members. These official journals provide authoritative and timely information on policies, plans, operations, and technical developments to both active and reserve components of a service.

A complete list of recurring publications, many of which are applicable to your maintenance operation, is found in AFR 0-2. Several representative recurring publications that contain articles of interest to you are:

No.	Publication Title	Issue/Yr
AFRP 11-1	<i>TIG Brief</i>	24
AFRP 30-15	<i>Airman</i>	12
AFRP 50-2	<i>Air University Review</i>	6

New or revised Air Force publications are listed in each section of the *TIG Brief*. These are advance notices of changed or new issues of regulations, manuals, visual aids, and other publications. Items that appear in the *TIG Brief* are those that point up "soft areas," which can become trouble spots. Thus, action can be taken before serious difficulties arise. Other items deal with management suggestions or oversights, important topics for planning purposes, and timely matters required by law or regulation. Quite frequently, checklists are published in the *TIG Brief*. These usually cover the highlights of a functional area; and the deficiencies are, of course, picked up by inspection teams from the Air Force Inspector General's office.

Exercises (071):

1. A formal course is available to train personnel to perform maintenance on a new item of equipment. What document should you use to find the location of, and prerequisites for, this course?

2. Some recurring publications contain pertinent information regarding maintenance safety. What Air Force regulation will list this type of publication?
3. What recurring publication, published twice each month, keeps you informed of the latest trouble spots of interest to the Air Force Inspector General?

4-3. The Air Force Technical Order System

As you already know, TOs provide the source of technical information for the equipment with which you will be working. In technical orders you find instructions and information pertaining to the operation, servicing, inspection, maintenance, modification, and overhaul of test equipment. Each time Air Force equipment is repaired or a modification is performed, a TO must be used for reference. Since the technical order file in your organization is such an important maintenance tool, it is imperative that you become proficient in understanding the overall technical order system. Although some of the following information may serve as a review, most of it introduces you to publications with which you may not be familiar or may not have had an occasion to use. In any situation, the following TOs provide you with the information for understanding the overall system. TO 00-5-1, *AF Technical Order System*, describes the system; and TO 00-5-2, *Technical Order Distribution System*, outlines the procedures for obtaining TOs.

The major groups of publications produced under the technical order system are listed below. Note that there are five groups of technical orders.

- (1) Technical manuals.
- (2) Time compliance technical orders.
- (3) Methods and procedures technical orders.
- (4) Index type technical orders.
- (5) Abbreviated technical orders.

Although you may not use all of these types of technical publications, other members of your section or shop may. Since many of the official procedures and instructions are taught directly from various documents in the technical order system, it would be to your benefit to become familiar with all types of technical orders. Before discussing the groups listed above, let us start our discussion with the technical order numbering system.

072. Identify the different parts of TO numbers with their meanings.

Technical Order Numbering System. The basic principles of the technical order numbering system provide for all publications of specific categories to be separated into primary (major) groups, usually by equipment. Each major group is subdivided into major types (subgroups) of equipment and then into the specific types and models of equipment, except for certain general instructions.

With the basic principles in mind, let us examine how a technical manual on an item of equipment is divided into three, four, or five parts, and the parts, in turn, separated by dashes. Each part of the TO number carries certain information.

Part one of a TO number. The first part of the TO number identifies three bits of information about the TO. The first bit is numerical and identifies the TO category. The second bit is alphabetical and identifies the major group of equipment. The third bit is numerical and identifies a specific type of major equipment. The information relating to the first part of a TO number is the same for all three, four, and five part TO numbers.

Three part TO number. Part two of a three part TO number identifies the equipment general series, type, model, or part number. Part three identifies the kind of TO.

Four part TO number. Part two of a four part TO number identifies a specific item or equipment type. Part three identifies the equipment general series, type, model, or part number. Part four identifies the kind of TO or section of a sectionalized TO.

Five part TO number. Parts two and three identify identical information as for the four part TO number. Part four identifies the kind of TO, while part five identifies the section of a sectionalized TO.

The definition of each part of a TO number is given in TO 0-1-33-1, *Numerical Index and Requirement Table for General Purpose Test and Associated Equipment*. For example, a partial listing of the definitions for "Kind of TO" is:

-1, 11, 21	Operating Instructions
-2, 12, 22	Service and Maintenance Instructions
-3, 13, 23	Depot Maintenance, Overhaul Instructions
-4, 14, 24	Parts Catalog, Illustrated Parts Breakdown

These basic principles apply to TOs initially prepared under the Air Force concept. Variations of these principles occur when a commercial manual or a manual prepared for another branch of the service is identified as an Air Force TO. An example of this is TO 33A1-5-106-1.

33	Test Equipment Technical Orders
A	General Purpose
1	Electrical and Electronic
-5	Frequency Measuring
-106	Model 500B
-1	Operation and Service Instructions

Exercises (072):

1. What is the significance of the -12 in TO number 33A1-12- 242-1?
2. Which part of a five-part TO number would represent the parts breakdown for a particular item of equipment?

3. Which part of the TO number identifies the TO category?

073. Describe the reason, the method, and selected procedures for making changes to existing TOs.

Technical Order Changes. The technical content of TOs is kept as current and accurate as possible. Equipment modifications, revised test procedures, errors in schematics or circuit explanations, or changed calibration procedures may require a simple pen-and-ink change to a page or the replacement of a page. On the affected pages, the obsolete material is deleted; and the new data is incorporated. The changed pages replace the corresponding numbered pages in the existing publication. All replaced pages are removed and discarded. If a change contains additional material that cannot be fully included on a replacement page, additional pages are issued and added to the affected publication. These additional pages bear the number of the preceding page augmented by a letter suffix. For example, additions to page 20 of a given publication are carried on pages 20A, 20B, 20C, etc., and are filed in that sequence.

Changed pages are identified by change dates printed on the bottom of each page. Changes in the text are indicated by a heavy black vertical line in the outer margin of the page, immediately opposite the changed part of the text. A new title page is issued with each change, bearing the original publication date and a change date. To insure that changes are not confused with new publications, the word "CHANGE" is printed across the face of the accompanying title page. Whenever change pages are issued to a publication, the List of Effective Pages on page A (inside the front cover) is updated to show the latest issue date. By referring to page A, you can determine the completeness and current status of the publications.

Exercises (073):

1. Why are changes made to Air Force TOs?
2. When a change to an existing TO is received, how is it incorporated into the existing TO?
3. How does the title page of a TO reflect changes in the TO?
4. How is the status of a TO determined as far as changes to the basic TO are concerned?

074. State the purpose of TO supplements, appendixes, and revisions; and explain how the inclusion of each is shown in a TO.

Supplements. Supplements to basic publications are issued as separate publications. They incorporate augmented or revised data that cannot be adapted to change pages or which would be more expediently, economically, or practically issued as supplements. Normally, supplements are cumulative; i.e., each succeeding supplement supersedes the preceding supplement and includes the data contained in it. Occasionally, however, it is necessary to issue supplements that are not of the cumulative type.

A supplement bears the same title as the basic publication and is assigned the same numerical designator, which is followed by a letter suffix. For example, TO 00-5-1 is supplemented by TO 00-5-1A, TO 00-5-1B, TO 00-5-1C, etc., in this order.

Appendixes. Appendixes to publications are used to include material that is not part of the normal sequence outlined in the table of contents, such as tables, charts, foldouts, or supplementary information. Such added material becomes an integral part of the affected publication. Appendixes may be issued either as a part of the basic publication or separately. In the latter case, the appendixes are issued with a changed title page to be substituted for the existing title page of the basic publication. The changed title page bears a revised publication date and a CHANGE strip. The pages of appendixes are then included at the back of the basic publication. Inclusion of an appendix in a publication is reflected on page A in a manner similar to that used for change pages.

Revisions. These are complete new editions of a publication and bear a new publication date. They replace the original publication, including any existing changes and appendixes, and, in most cases, all existing supplements. When changed material affects more than 80 percent of the text, the publication is normally revised.

Exercises (074):

1. When is a supplement issued for a basic TO?
2. How is a TO supplement identified?
3. Why are appendixes to TOs published?
4. How does the TO reflect that an appendix has been issued as a separate publication from the basic TO?

5. What determines the use of a revision in the TO system?
6. How are changes to an existing TO affected by a TO revision?

075. Identify various index type technical orders with designating numbers and/or particular information requirements.

Index Type Technical Orders. As a maintenance technician, you will have many occasions to refer to the indexes to determine if a technical publication covering a particular subject exists. Let us see what information of this type is available from the indexes.

Numerical index and requirement tables (NI&RTs). These are documents that list all of the categories within the technical order system as well as supplements to each category index and requirement table.

Actually the -01 publication is a numerical index to all authorized individual indexes. The numbering applied to NI&RTs covers a category of TOs based on functional usage and family grouping of equipment. The TO numbers listed in 0-1-01 are divided into three or more parts. For example, the TO number 0-1-1-1 is divided as follows:

0-	Numerical Indexes, NI&RT, Alphabetical Index, and Cross Reference Tables
0-1	Numerical Index and Requirement Tables
0-1-1	Aircraft Technical Orders
0-1-1-1	Sectionalized TOs

Notice the following list of TO indexes for which the "0" prefix is again used:

TO 0-1-1-1	General Aircraft Technical Orders
TO 0-1-1-2	Bomber Aircraft TOs
TO 0-1-1-3	Cargo and Special Electronic Aircraft TOs
TO 0-1-11-6	Chemical and Biological Warfare Agents, Decontaminating, Impregnating, Protective, and Hazard Detecting Equipment TOs
TO 0-1-33-1	General Purpose Test and Associated Equipment TOs (33 category)

The individual indexes can be supplemented at any time by separate publications. These supplements carry the same numbering system as the basic document; however, each supplement to a basic document also carries a sequence of letters; e.g., TO 0-1-11-1C, 1D.

The NI&RTs are used to gather quantitative requirements for technical publications so that new publications, changes, supplements, and revisions of existing publications may be distributed to your organization as soon as they are available.

While many of the various types of publications in the Air Force technical order system are unclassified documents, there are a great number that do carry security markings of CONFIDENTIAL, SECRET, and TOP SECRET. These are rigidly controlled publications which are governed by the need-to-know principle.

Alphabetical listing of equipment and technical order number groups. This index (TO 0-2-1) has a function similar to that of the alphabetical index for standard Air Force publications. However, this index pertains strictly to technical order publications. The alphabetical listing provides an easy method for locating the correct technical publications number groups when the type of equipment is known. For instance, assume that you want to locate a TO that covers a particular accelerometer on a bombing system. Reference to TO 0-2-1 shows that accelerometer bombing systems and equipment fall under technical publications number group 11B63. Thus, all TOs dealing with accelerometers for bombing systems will have a TO number that begins with 11B63.

Cross-reference tables. One index of this type is TO 0-4-2, *Cross-Reference Table of Time Compliance Technical Orders to Applicable Data Code Numbers*. TO 0-4-2 provides a cross-reference listing of data code numbers assigned to active time compliance technical orders (TCTOs). These data codes are used in the maintenance data collection system outlined in AFM 66-1, *Maintenance Management Policy*. A data code is more convenient to use in the automated data processing system than TCTOs. The maintenance forms used in this system are discussed in a later chapter.

A second index of this type is TO 0-4-6-1, *Numerical Cross-Reference Equipment Numbers to Air Force Technical Order Numbers*. This TO provides a numerical listing of equipment model numbers which are cross-referenced to technical order numbers. This enables you to identify the technical order, if one is in print, for test equipment items you receive in the PMEL. It should be noted that this index may list several TOs for a particular equipment model depending on how many different kinds of TO have been identified or published.

List of Applicable Publications (LOAP). LOAPs provide listings of all TOs applicable to the specific equipment covered. The LOAP enables you to select and become familiar with publications pertinent to the specific Air Force equipment with which you will be working. This allows you to determine the contents of a limited TO file to be established for your organization.

Exercises (075):

1. How is the TO number for an index identified?
2. What is the significance of the third number group in an index TO?
3. How are supplements to an index identified?

4. Which index provides a TO number group when only the type of equipment is known?
5. Which publication would you consult for guidance in setting up a TO file in your unit?

076. Identify technical manuals by type, information contained, and characteristics; and clarify certain procedures related to them.

Technical Manuals. Publications in this broad grouping of the system are those which contain detailed information and instructions required for the operation, maintenance, inspection, overhaul, and identification of parts of aircraft, missiles, and other related equipment.

Air Force type publications. A glance through TO 0-1-01, which you will recall is the index to all individual numerical indexes, shows that approximately 50 categories and subcategories could have technical manuals. Of these 50 general categories, you'll find that many of the technical information publications have been prepared for the following:

- a. Aircraft engines.
- b. Missile engines.
- c. Nonaeronautical engines.
- d. Accessories.
- e. Airborne electronics.
- f. Ground electronics.
- g. Test equipment.
- h. Automotive equipment.
- i. Field and shop equipment.
- j. Marine equipment.
- k. Standard commercial equipment.
- l. Missile (direct support, real property) installed equipment.

Some of the items in the preceding list are standard in both the Army and the Air Force. When Department of the Army publications are found applicable for Air Force use by the Air Force Logistics Command (AFLC), they are given technical order numbers and listed in the appropriate numerical indexes.

For the items of equipment listed, there are many types of technical manuals published. Naturally, not all types apply to each item. Only by consulting the appropriate NI&RTs can you determine their applicability. The types of technical manuals you may find in various indexes are as follows:

- a. Operating Instructions.
- b. Service Instructions.
- c. Operation and Service Instructions.
- d. Operation, Service and Repair Instructions (condensed).
- e. Intermediate Maintenance Instructions (formerly Field Maintenance Instructions).
- f. Preventive Maintenance Instructions.
- g. Installation Instructions.

- h. Standard Installation Instructions.
- i. Overhaul Instructions.
- j. Overhaul Instructions with Parts Breakdown.
- k. Reconditioning Instructions.
- l. Illustrated Parts Breakdown.
- m. Inspection Requirement.
- n. Work Unit Code Manuals (TO 00-25-06 series).

Commercial type publications. Commercial type publications come under the category of technical manuals. They are normally furnished by the manufacturer of an item of equipment purchased by the Air Force. Quite often, a commercial publication is placed with a crated item of equipment. In this case, the publication may furnish instructions on the assembly, installation, operation, servicing, overhaul, and parts identification of the manufacturer's product. When commercial publications are identified by the manufacturer as interim data, these publications are authorized for use, until formal printed technical orders become available.

When replacement commercial publications are needed, they may be requisitioned through numerical index and requirement tables, if TO numbers have been assigned to them. If a thorough investigation shows that the technical data is not available through the technical order system, local procurement from the manufacturer is authorized.

Exercises (076):

1. What type of information is contained in technical manuals?
2. Which TO numerical index includes the general categories and subcategories of equipment?
3. What Air Force organization determines the applicability of Army publications to Air Force use?
4. Who produces commercial manuals relating to a particular item of equipment, and how can you obtain the manual?

077. List the categories of time compliance technical orders (TCTOs); state their purpose, and identify each category with special purposes, markings, conditions for issue, and/or required responses.

Time Compliance Technical Orders (TCTOs). Time compliance technical orders are the media through which extensive modifications and modernization programs are directed. *Immediate action*, *urgent action*, and *routine action* TCTOs are the three main categories you will

encounter in your work, although you may occasionally encounter *interim* and *record* TCTOs.

Immediate and urgent action TCTOs. Immediate action TCTOs are used for correction of conditions that could result in a fatal or serious injury to personnel or extensive damage or destruction to valuable property. Urgent action TCTOs are used to correct potentially hazardous conditions or conditions affecting mission necessity—factors that could result in injury to personnel, damage to valuable property, or unacceptable reduction in operational or combat efficiency. To focus attention on these two time compliance technical order categories, border marks and identification notes are printed in red. In addition to providing a distinctive identification, the red markings (red Xs for immediate action and red diagonals alternately spaced with circled red Xs for urgent action) correspond to the symbols used to make entries on maintenance forms.

Routine action TCTOs. These TCTOs are used for correction of equipment or procedural deficiencies which could constitute a hazard through prolonged usage. These technical orders are without distinguishing red symbols and are issued in two separate categories (Category 1 or 2) based on the primary responsibility for accomplishment. *Category 1* TCTOs require compliance by organizational and field maintenance activities. Such orders specify that work will be done within a specified number of days, or concurrent with an event, *Category 2* TCTOs require compliance by depot level maintenance activities. These orders require that the necessary work will be done during the next IRAN (inspection and repair as necessary) or overhaul. The recission dates for category 2 TCTOs must not exceed 48 months.

Interim and record TCTOs. When the urgency of conditions does not allow time for printing and distribution of instructions in formal TO format, the instructions are distributed by means of interim TOs. The interim information may be transmitted by radiogram, telegram, teletype, messageform, or any other type of speedy communication. They are normally used to issue new modification or compliance instructions. As a general rule, interim TOs are replaced by formal TOs within 10 days. The formal TO then falls into one of the other categories of TCTOs.

Record TCTOs are issued when the modification must be by a contractor or specific Air Force activity.

Exercises (077):

1. List the three main categories of TCTOs.
2. What is the purpose of TCTOs?
3. What is the major difference in the purpose of an immediate action and an urgent action TCTO?

4. Explain the markings that would enable you to differentiate between immediate action and urgent action TCTOs.
5. What is the purpose of the routine action TCTO?
6. Which level of maintenance is responsible for accomplishing each category (Categories 1 and 2) of a routine action TCTO?
7. What condition warrants the issue of an interim TCTO?
8. What is the normal time period for interim TCTOs to remain in effect and by what means are they transmitted?
9. When are record TCTOs issued?

078. State the purpose of methods and procedures TOs and explain how they are identified.

Methods and Procedures Technical Orders. Publications of this type provide information and instructions in various subject areas. These technical orders include the following general publications:

- 00-5 series, Air Force Technical Order System—General
- 00-20 series, Maintenance Management System—General
- 00-25 series, Miscellaneous TOs—General
- 00-35 series, Administrative TOs—General
- 00-75 series, Air Evacuation
- 00-80 series, Special TOs
- 00-85 series, Protective Packing and Preservation Packaging—General
- 00-110 series, Special Weapons Defense and Nuclear Application, Monitoring, Handling, Disposal, and Decontamination—General

Methods and procedures technical orders are printed in the same format as aircraft and equipment technical manuals. A complete listing of these publications is found in TO 0-1-02, the index to general publications in the 00 category.

Exercises (078):

1. What is the purpose of a methods and procedures type TO?

2. How does the numbering of a TO indicate that it is of the methods and procedures type?

079. State the purpose of abbreviated technical orders and describe the format of a particular type.

Abbreviated Technical Orders. Primarily, these technical orders are used as work simplification devices which aid personnel in carrying out instructions that are contained in other types of technical orders.

Inspection workcards. These are sets of cards that list the inspection requirements given in the -6 technical manual in a checklist form. Because they are card size, they can be taken onto the job while performing a scheduled inspection. Work assignment information is given on each card; this feature makes it convenient when assigning work to maintenance personnel. Also, the work can be arranged by areas, leading to efficient maintenance scheduling and planning. The inspection requirements on each card are arranged to provide a logical sequence of performance. Charts on the reverse side of selected cards pictorially locate each work area and indicate the code and title of the areas referred to in each set of cards. In the planned inspection maintenance concept, the inspection workcards are used with the inspection sequence charts.

Inspection sequence charts. These are also provided in sets similar to the workcards. However, sequence charts are used only for periodic inspections; and they show a basically planned work schedule or sequence which permits efficient accomplishment of the inspection. The charts serve as a guide in preparing the actual work schedule for each particular inspection, and they are intended to control the assignment of work during an inspection.

Checklists. Originally this type of abbreviated technical order was used only by aircraft crewmembers. The contents of such flightcrew checklists give a series of items that could be used to perform preflight, inflight, and postflight checks.

Checklists are now available for use in many avionics maintenance operations. These checklists contain tasks listed chronologically for a maintenance team to perform. Each task is performed in the proper sequence and is checked off when it has been completed. Certain checklists are arranged in a two-column, demand-response format. Demands, which are the tasks listed in sequence, are listed in the left-hand column; and responses to the demands are marked in the right-hand column. Like the workcards, checklists are printed in sets and in a size that is convenient to use on the job. The letters "CL" are part of a checklist's technical order numerical designator.

You may use checklists that are authorized and prepared by the headquarters of your particular command. You may use other checklists prepared locally by your maintenance activity. In any case, the importance of following the steps as given in these checklists cannot be overemphasized.

Exercises (079):

1. What is the purpose of abbreviated TOs?
2. Describe the format of a two-column, demand-response checklist.

080. State the purpose of preliminary TOs and the means of listing and identifying them.

Preliminary Technical Orders (PTOs). Preliminary technical orders are prepared in limited quantities to test and to verify certain procedures that were developed for use with the first test or early production models of some weapon systems or their ground support equipment. Unlike some publications in the technical order system, preliminary technical orders are not controlled by the pertinent NI&RT. Since these are a special kind of technical order, only a few organizations will be authorized to request and maintain limited files of preliminary technical orders.

These limited technical orders are identified by the word "PRELIMINARY" printed on their title page and by their sequential copy numbers, e.g., number 5 of 200. The customary technical order numbering system is used to identify preliminary technical orders along with the usual title and A pages. Limited files of formal technical orders do not include preliminary technical orders. The latter must be maintained in a separate file that must be clearly marked. Changes and supplements to preliminary technical orders are handled in the customary manner. When a preliminary technical order has been accepted and approved for Air Force operation and maintenance use, the word "PRELIMINARY" and the sequential control number are deleted from the title page. A replacement note is printed on the title page. It states that the issued publication replaces the pertinent preliminary technical order.

Exercises (080):

1. Why are preliminary TOs issued?
2. Which NI&RT lists applicable preliminary TOs?
3. How are preliminary technical orders identified?

081. Cite factors to be considered before submitting TO deficiency reports, conditions justifying them, and required responses; and specify selected details of AFTO Form 22 preparation.

Technical Order Improvement Reporting. In your day-to-day use of TOs, you will probably find errors in the written material or the illustrations. Some are obvious typographical errors; others are erroneous instructions or information. The former are not serious, but the latter can be. The TO improvement reporting system provides a means of correcting serious errors by the use of AFTO Form 22, Technical Order System Publication Improvement Report and Reply. (See fig. 4-1.)

Specialists, mechanics, and/or supervisors may have difficulty in determining whether or not a TO improvement is of a type which should be reported. TO 00-5-1 states that a TO improvement is a suggested correction of an error that affects the meaning of instructive information or prevents adequate performance of functions required for mission accomplishments. It further explains by saying that minor inaccuracies of a nontechnical nature are not considered deficiencies unless they change the meaning of instructive information and procedures.

Types of TO improvement reports. Prior to submission, a TO improvement report is assessed in terms of mission impact, personnel and aerospace safety, damage to equipment, work simplification, urgency of need for change, and manpower savings. The criteria outlined in the following paragraphs determine which of the three types of improvement report is submitted.

(1) **Emergency reports.** These reports require immediate correction of a TO deficiency involving safety and unit mission which, if not made, would result in fatal or serious injury to personnel, extensive damage or destruction of equipment or property, or inability to achieve or maintain operational posture (mission essential). Emergency reports are prepared in electrical message format and assigned a precedence of "IMMEDIATE." They are transmitted to the AFLC activity concerned and are identified as "EMERGENCY AFTO FORM 22." The activity responsible for correcting the deficiency takes action within 48 hours by issuing an interim safety or operational supplement, interim time compliance TO, or disapproving or downgrading the report. Should the report be disapproved or downgraded, a message is sent to the originating quality control within 48 hours.

(2) **Urgent reports.** These reports recommend nonemergency correction of a TO deficiency involving a hazardous condition, which, if not made, could result in personnel injury, damage to equipment or property, reduce operational efficiency, or jeopardize the safety or success of mission accomplishment. These reports are submitted through major command level to the applicable AFLC activity. The activity responsible for correcting the deficiency issues a corrective TO change, revision, or supplement within 30 calendar days. This time period includes printing and distribution time, but using activities must allow for mail and redistribution time. Should the report be disapproved or downgraded or if action cannot be completed within 30 calendar days, the AFLC activity

replies within 20 calendar days by AFTO Form 22, indicating the reason for the action taken.

(3) Routine Reports. These reports recommend improvements in TOs which, if not made, may result in a potential hazardous condition through prolonged use, have a negative effect on operational or maintenance efficiency, or reduce operational life or general utility of equipment. They also describe TO improvements relating to work simplification, manpower and manhour savings, and clarification of procedures. These reports are also submitted through major command level to the applicable AFLC activity. The activity responsible for correcting the deficiency replies to all routine reports within 60 calendar days on AFTO Form 22 advising of the action taken or the reason for disapproval. Normally the changes, revisions, or supplements are published within 240 calendar days after receipt.

Preparation and submission of AFTO Form 22. In figure 4-1, block 11 (Reported By), the signature belongs to the person who discovers the TO deficiency. The AFTO Form 22 comes close to being a personal report, by the technician of any grade, to those who can correct the deficiency. Block 11 provides a record of the person who knows the problem. Care should be taken not to enter the name of the supervisor or crew chief in this block. Blocks 12 and 13 require the signature of the supervisor and a quality control or operations standardization officer.

TO 00-5-1 provides detailed instructions for preparing and submitting an AFTO Form 22. Read the entire section and follow the instructions step by step when preparing a report, particularly the first one you prepare. After that, preparing a report will be a simple matter.

Exercises (081):

1. Cite the factors to be considered before submitting a TO deficiency.
2. List the three TO deficiency reports and describe the type of deficiency for which each report is made.
3. What action is taken by the appropriate AFLC activity upon receipt of a valid emergency TO deficiency report?
4. A valid urgent report requires that a change, revision, or supplement be published within what time period?
5. Who prepares the AFTO Form 22?
6. How is indiscriminate use of the AFTO Form 22 prevented?
7. Which AF publication provides detailed instructions for the preparation of the AFTO Form 22?

Maintenance Management

YOU AND THOUSANDS of other Air Force personnel are involved in maintenance to keep our complex equipment ready for use. In fact, you are part of a worldwide maintenance program. This maintenance program has the responsibility for the calibration and repair of aircraft, missiles, AGE, ground communications, simulators, trainers, and precision measuring equipment. In essence, this maintenance function is responsible for the maintenance of everything except vehicles and real estate. You can see that a function of this magnitude demands streamlined management and your strict attention to detail. With a detailed knowledge and appreciation of the importance of the Air Force maintenance system, you will add to the effective operation of your local maintenance management and inspection team. The maintenance management function is divided into several categories in AFM 66-1.

5-1. Maintenance Organization and Functions

NOTE: For objectives 082-095 study objectives 001-014 in Module 10004, *Maintenance Management*, which accompanies this volume. When you complete Module 10004, return to the text.

Module 10004

Maintenance Management

CDC 32450-1 Objectives *Module 10004 Objectives*

082	001
083	002
084	003
085	004
086	005
087	006
088	007
089	008
090	009
091	010
092	011
093	012
094	013
095	014

5-2. Materiel Deficiency Reporting System

Today we are all familiar with the recall of automobiles to correct deficiencies. The Air Force is no different. From time to time, items of equipment are found to have contributed to an accident or incident, or to have created a safety hazard. Some of these items are caught through analysis of the maintenance data collection system. However, the Air Force

also depends on each individual to report materiel deficiencies. You will always have plenty of help when you make a materiel deficiency report, because there are normally many people involved in such a report. The responsibility for clearance and control of materiel deficiency reports is assigned to Quality Control. If you ever have to make out one of these reports, always check TO 00-35D-54, *USAF Materiel Deficiency Reporting and Investigating System*, to make sure that you have the latest information. Also be sure to check with your quality control section for up-to-date advice on materiel deficiency reporting. Now let's see what type of reports are available and how they are defined.

096. State which type of materiel deficiency report you should use in given cases.

Reports. There are two classes of reports that may be submitted—Category I and Category II. The Category I report is used to report emergency conditions of a safety nature on all types of equipment. This report is submitted to the office having the prime responsibility, called an action office, by priority communications. The Category II report is used to report quality deficiencies that at the present reveal no safety hazards but that may develop into a hazard through prolonged usage. The Category II report is submitted as a routine communication.

The Category I and II materiel deficiency reports are used to report deficiencies caused by component failure, improper design, nonconformance with specifications, etc. The reports are not used to report nonperformance related deficiencies such as might be caused by inshipment damage. This type of damage is reported through other documentation, such as DD Form 6, Packaging Improvement Report.

Category I report. This report relates to those deficiencies which could cause damage to persons or equipment either airborne or on the ground. The type of deficiencies that primarily relate to PME are of the type that may subject personnel to exposure to lethal voltages, excessive radiation, or some mechanical hazard. Accordingly, the deficiency that could place 120 volts AC on the chassis of a voltmeter would be reported as a Category I deficiency report.

Category II report. This report details nonsafety deficiencies such as nonconformance to specifications, poor workmanship, or missing components in new equipment. Other deficiencies that at the present are no problem but which at some time in the future may create a hazard or shorten the useful life of the equipment are also submitted as a Category II report. An example of this type deficiency would be a resistor that shows signs of overheating under

normal operating conditions in a number of like items of equipment. One or two such reports may not constitute a valid deficiency; however, a large number of reports could reveal a design deficiency.

Documentation. Both categories of reports contain essentially the same information with the difference being the method of preparation and submission. The Category I report is prepared directly on a DD Form 173, Joint Messageform, while the Category II report is first prepared on the SF 368, Quality Deficiency Report (Category II), and then transferred to the DD Form 173. The SF 368, after submission through normal channels, provides for follow-on actions to document investigative and corrective results. Basically, the data documented includes:

- a. Submission data (From—To—Date).
- b. Item identification (Manufacturer—Stock Number—Nomenclature).
- c. Manufacturer's identification (Part Number—Lot Number).
- d. Deficiency (Symptoms—When failure occurred).

The equipment containing the deficiency is normally kept as an exhibit as evidence of the deficiency. At times there may be no exhibit, because the equipment may have been destroyed through the event that made the deficiency apparent. In either case, exhibit availability is documented in the deficiency report.

Exhibits. An item of equipment (exhibit) that supports the materiel deficiency report is held in a secure area to insure that the exhibit is not altered or lost. The action office, after processing the deficiency report, sends instructions relating to the disposition of the exhibit. These instructions may

require shipment of the exhibit to the action office, disassembly and analysis by a local activity, or some other action such as disposal without disassembly and analysis.

The maintenance management concepts that we have presented are in a general nature. Due to the various concepts that are available—avionics, missile, communication--electronic-metrological, field, organizational, technical training center—it is impossible to cover all concepts in this CDC. You must, in order to understand the concept at the laboratory to which you are assigned, study AFR 66-1 as it applies to your base.

Exercises (096):

1. A new signal generator in a broken carton is received from supply. After removing the signal generator from the carton, a hole is discovered in a side panel of the generator. Would this be reason for submitting a materiel deficiency report? Explain.
2. Which type of deficiency report would be submitted when personal safety is of concern?
3. For which type of report is the SF 368 used?

USAF Calibration Program, Laboratory Practices, and Supervision

THROUGHOUT our discussion in the first chapters of this volume, we presented the various aspects of the job as they relate to you:

- Your progression in the career field.
- Your responsibilities to the Air Force operational security program.
- Your safety and safety as it relates to the equipment you use.
- Your acquaintance with publications necessary to do the job.
- Your part in the overall maintenance management system.

Now we are ready to talk about the USAF calibration program.

6-1. USAF Calibration Program

You should be anxious to learn all you can about the USAF calibration program. You are one of the hundreds of precision measuring equipment specialists who are responsible for its operation.

Background. Worldwide deployment of Air Force weapon and support systems generated requirements to test, adjust, peak, calibrate, repair, and maintain systems, subsystems, equipment, components, and test equipment to assure operational effectiveness and accuracy of our weapon systems. The comparison system in effect in the early 50's did not assure compatibility from base to base and from force to force. A single integrated calibration system that provided measurement traceability from the National Standards to base level was proposed and approved by HQ USAF. This program was structured to have the commands operate the base precision measurement equipment laboratories (BPMELs) and AFLC to be the scientific, technical, and logistic manager and the single focal point with the National Bureau of Standards (NBS). The responsibilities were delegated to the Dayton Air Force Depot. The organization is the direct antecedent organization of the 2802nd Inertial Guidance and Calibration Group, which was designated the Aerospace Guidance and Metrology Center (AGMC) as of 8 November 1968.

In recognition of increased sophistication not only with the advent of ballistic missile systems but also the increased accuracy requirements for aircraft and support systems, improved standards, precision measuring equipment, and facilities for calibration were required. The Air Force Measurements Standards Laboratory to serve the needs of the worldwide bases was proposed to be located in an Air Force-owned facility at Newark AS, Ohio. The go-ahead was given in 1959 and the laboratory was completed in

mid-1962 and operation transferred from Dayton to Newark. Also in 1959 a program of acquisition of precision measuring equipment and standards was started to provide 160 base PMELs and 17 air materiel area (AMA) laboratories with standards to provide the minimum measurement capability commensurate with true measurement requirements. These standards were traceable from the National Bureau of Standards through the Dayton Air Force Depot, through the AMA laboratories to the 160 base PMELs. Limited accuracies only were covered at the bases. The more sophisticated equipment used to satisfy extreme accuracy requirements was provided only to the AMA type laboratories. This required a constant change of equipment and use of AMA manpower to maintain the NBS traceability channels. Considerable groundwork and planning have been done in the calibration area prior to this time; however, this was the first major attempt to establish and control a single integrated measurement standards system throughout the Air Force.

In 1962 upgrading the base PMELs was begun. Three measurement areas were covered: the electrical, microwave, and mechanical measurement standards packages. These measurement areas are upgraded on a continuing basis to keep abreast of latest technological developments and current state-of-the-art.

097. Identify the goals of the calibration program, the one that most closely relates to you, and the regulation that governs the program.

Program Goals and Regulations. The fulfillment of the goals established for the USAF calibration program is due in part to the AF regulation which governs the program. This regulation outlines policy and assigns responsibility for the management of the program. It applies to all Air Force activities that are responsible for the design, development, control, maintenance, and use of precision measuring equipment. We are referring to AFR 74-2, *Air Force Metrology and Calibration Program (METCAL)*. We first identify the goals and then examine the regulation.

Program goals. The primary goals to be achieved by the USAF calibration program (USAF single integrated calibration system) are as follows:

- a. Establish a base-level capability for the calibration and/or repair of all types of test equipment.
- b. Establish a system to maintain, calibrate, and distribute standards.

In the statement of the goals of the USAF calibration, each word or group of words should have special meaning to all precision measuring equipment technicians. Let us examine

the word groups in the first goal (a) to see if we can supply the proper interpretation of each group. Examine the interpretations that follow to see if you agree:

a. Base-level capability—A base is equipped with the necessary facilities, standards, and trained personnel.

b. Calibration and/or repair—This word group implies the assessment of a dual responsibility: calibration and repair.

c. All types of test equipment—The meaning here is clear: any item of test equipment.

The first goal (a) restated says that each base should be equipped with the necessary facilities, base standards, and trained PME technicians to calibrate and/or repair all types of test equipment. Let us examine the words of the second goal (b) to see if we can provide adequate interpretations for each.

a. System—This word implies an organized procedure is established.

b. Maintain—This word refers to the responsibility to store, to guard from damage, and to keep at its assigned operating efficiency.

c. Calibrate—This word represents the process involving the comparison of one item with a standard. The technical definition for this word also includes the process of adjustment.

d. Distribute—In the USAF calibration program, calibration standards are assigned to base laboratories. The word also includes the process of shipping or delivery.

e. Standards—This word refers to items of precision measuring equipment whose calibration accuracies are many times greater than the accuracies of the equipment being calibrated.

As you have examined the words and phrases contained in the two goals of the USAF calibration program, you probably have thought of additional definitions or interpretations which you would have given. As long as there is no conflict in basic concepts, this is good. When you compare the goals stated, we want you to realize one goal is concerned with the base-level capability to do the jobs to which you are assigned, and the other goal is concerned with the means of supplying your laboratory with the standards you need for calibration purposes. Let's examine the Air Force regulation (AFR) that was prepared to implement the USAF calibration program.

Implementation regulation. Air Force Regulation 74-2 establishes official guidelines for you and all other personnel engaged in organizational, field, AMA, and Air Force level maintenance of precision measuring equipment. The guidelines are provided in the various paragraphs of the regulation. Some of the titles for the paragraphs are as follows:

a. Explanation of terms—terms such as Air Force Metrology and Calibration Program, metrology, precision measuring equipment (PME), precision measurement equipment laboratory (PMEL), calibration, and certification.

b. Need for a system to control measurement accuracies.

c. Types of standards used in measurement and testing.

d. Relationship with other related programs.

e. How the Air Force Metrology and Calibration Program is organized.

f. HQ USAF office of primary responsibility (OPR).
g. Responsibilities of all major commands.

We have listed the titles so that you will know where to find certain information whenever it is required. It is not necessary that you learn the regulation word for word. But you should know why it was written and what it contains. One of our primary concerns in the preceding list is the last paragraph title listed. The paragraph under this title charges the major commands with the responsibility of assuring that competent personnel are used in the repair, calibration, and certification of precision measuring equipment. You are one of these competent persons to whom the regulation refers.

Exercises (097):

1. What are the two goals of the USAF calibration program?
2. Which of the two goals mentioned in exercise 1 are you more directly associated with as a PME technician?
3. What regulation is used to implement the USAF calibration program?

098. Specify selected organizational and operational details of the USAF calibration program.

Organizational and Operational Details. Let's continue our study of the USAF calibration program by examining the governing organizational and operational details prescribed in the governing technical order, TO 00-20-14, *Air Force Metrology and Calibration Program*. In addition to the implementation of AFR 74-2, this technical order establishes the policies and rules that govern the organization and operation of the USAF single integrated calibration system.

To fully understand the organization and operation of the USAF calibration program, you must consider the methods used to provide Air Force units with appropriate calibration service and associated reference standards which are used in the calibration of PME. Figure 6-1 is included to show the organization of the USAF calibration program and the relationships existing between the participating organizations. While studying the rest of this chapter, refer to this organizational chart showing the measurement traceability of the USAF calibration system. Note that the National Bureau of Standards occupies the top position in the calibration system, because the NBS establishes and maintains the highest echelon of calibration reference standards of measurement in the United States.

Calibration and certification of standards. Periodic calibration and certification of standards are essential to the calibration program. Because of the different characteristics of various types of standards, each type is calibrated and is certified by specific procedures.

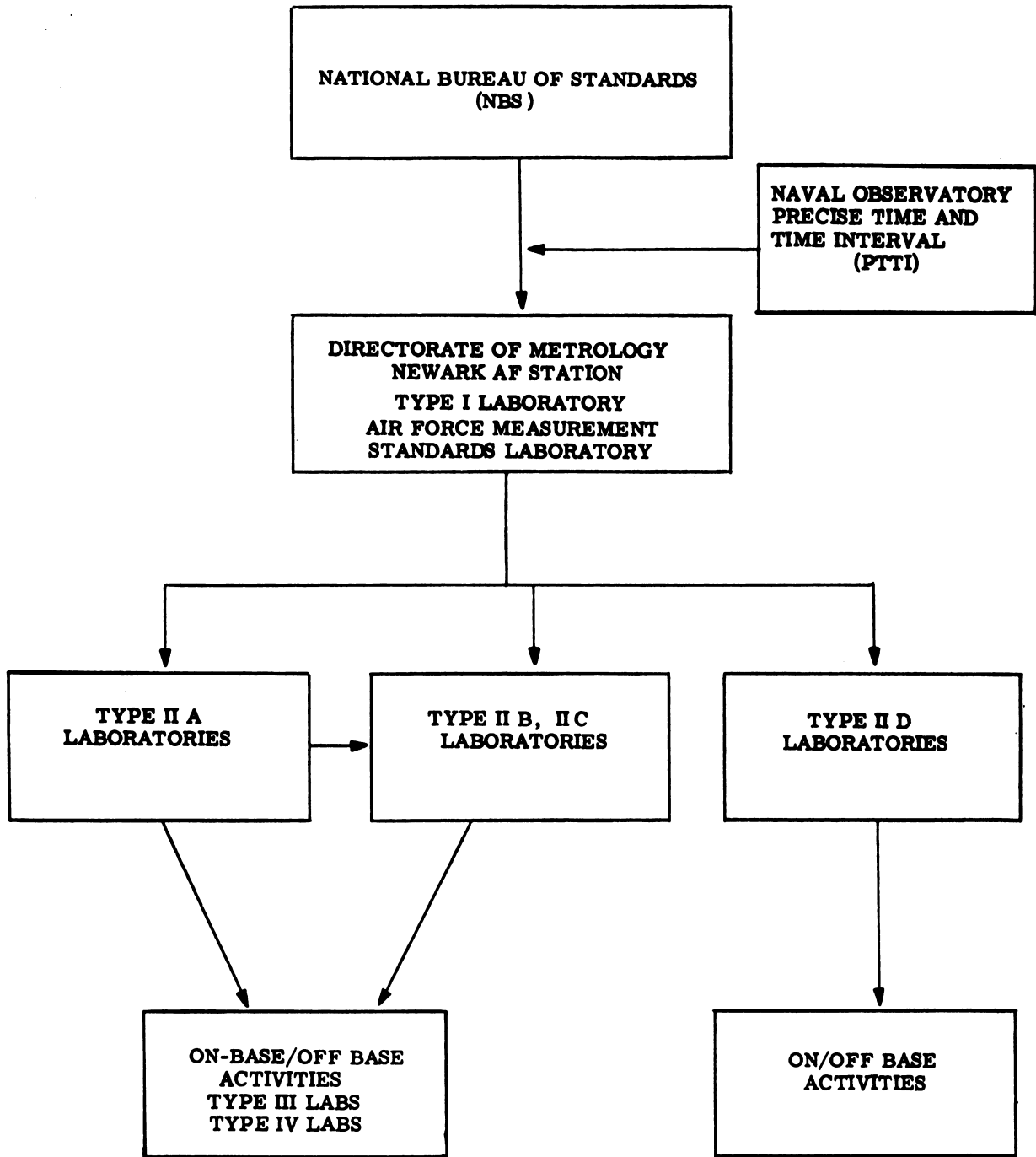

Figure 6-1. Measurement traceability.

Except for Precise Time and Time Interval Standards certified by the U.S. Naval Observatory, Air Force Reference Standards are certified at regularly prescribed intervals by the NBS. Measurement reports and correction data provided by the certifying agency remain with the standard as long as it is used as an Air Force Reference Standard. As indicated in figure 6-1, the Directorate of Metrology is the Air Force focal point of contact with the NBS and with the U.S. Naval Observatory to assure technical compatibility of the USAF calibration services for the Air Force.

Air Force Base Reference Standards are certified at regularly prescribed intervals by the NBS, the Naval Observatory, or the USAF Measurement Standards Laboratory as determined by the Directorate of Metrology. These standards are hand-carried or shipped to the PMEL in exchange for like items which are due for certification or are certified by transferring measurement data at the PMEL where the standards are located. (The maintenance-to-maintenance concept applies to the exchange process. Later in this chapter, we discuss how this concept allows the bypassing of base supply accounting units.) Other items of equipment identical or equivalent to certified Air Force Base Reference Standards are considered working standards and are the responsibility of the PMEL to certify. These standards will not be returned to AGMC for calibration.

Working standards are calibrated by the PMEL, using reference standards. AFTO Form 108, PME Certification Label, is affixed and certified by laboratory personnel. Working standards are used by the PMEL to support work performed there by traveling teams, in support of base activities which have no calibration capability, and by off-base Air Force activities.

Calibration and certification of PME. Calibration and certification of PME are performed as prescribed in 33K or 33L series technical order calibration procedures. The PMEL has calibration responsibility for items in the equipment listing in TO 33K-1-100 when 33K or 33L series technical orders are used. When no 33K or 33L series technical order calibration procedure is available, calibration will be performed as follows: First, in accordance with the applicable maintenance technical order; second, by commercial data; and third, by locally developed calibration procedures. In the latter case, a copy of the local procedure will be submitted to the Directorate of Metrology for approval and assignment of a 33L-series number. The maximum interval for PME is 6 months when an interval is not prescribed by a technical order. Common PME and measurement standards calibration intervals listed in weapon system or equipment calibration measurement summary technical orders and TO 33K-1-100 take precedence over the intervals listed in other technical orders.

There is no minimum time interval between calibration periods of PME. A calibration interval may be shortened by either the owning organization or by the PMEL. PME exposed to rough handling or to overloading is recalibrated, regardless of the calibration due date. PME that has exceeded the prescribed calibration interval or that has not been calibrated will not be used.

Many items of PME are designed to operate over a wide range but are used only for a portion of, or at certain points within, a wide range. In this case, you need to calibrate the item at the points where it is used. This limited calibration must be clearly indicated on the item. The using organization will specify desired calibration points or ranges.

Because of lack of equipment and technical data, situations arise in which the PMEL is unable to completely calibrate certain items of PME. When this happens, contact the PME user to determine whether or not partial calibration will suffice. If not, the calibrating work center that lacks capability to calibrate assigned PME must take the following steps (these instructions apply equally to an item of PME that cannot be calibrated at all by the local PMEL):

(1) The request for assistance is forwarded through channels to the major command for certification (command certification that the requirements are mission essential and beyond practical limitations of command resources).

(2) The using command makes the certification and forwards the request to the area AFLC Air Logistics Center. If the ALC does not have the capability, it notifies the PMEL.

(3) Calibration support requirements beyond ALC capability are submitted to AGMC.

All accessories needed for calibration of an item are delivered to the PMEL with the item as a complete package. Any questions concerning a need for such accessories should be coordinated with the user. The PMEL may return any item that is not complete enough to allow calibration.

The following is a listing of the prime responsibilities of the PMEL:

a. Operating and maintaining the highest echelon of calibration reference standards assigned to the base.

b. Calibrating, certifying, and repairing all common and designated peculiar PME of the host, tenant, and off-base supported AF organizations (including the Air National Guard and the Air Force Reserve units). All PME will be repaired, calibrated, and certified as prescribed in AFR 74-2, TO 00-20-14, TO 33K-1-100, and AFM 66-1.

c. Supporting contractors at Air Force bases and installations who are performing work under any DOD support agreement or contract.

d. Within available resources, providing support to other DOD agencies in accordance with AFRs 172-3 and 400-27.

e. As approved by Headquarters USAF, providing support to other Federal agencies and security assistance program country calibration programs.

f. Participating with supported activities in the calibration of peculiar PME and operational systems equipment upon request.

To assure that each PMEL demonstrates and maintains the capability to perform accurate calibrations, the Directorate of Metrology has a program of certification and evaluation. By analyzing the results of this program, they can determine a PMEL's capabilities and deficiencies.

Each PMEL will be evaluated and certified annually by the Directorate of Metrology to determine technical competence to perform calibrations and the adequacy of the facilities in which the calibrations are made as accomplished either by a visiting team from the Directorate of Metrology at least once every 3 years or by review analysis of evaluation data.

Each PMEL will be evaluated by a visiting team from the Directorate of Metrology at least once every 3 years. A PMEL that has been certified with limitations anytime during the past 3 years will be scheduled for an evaluation visit at the next certification anniversary and subsequent certification anniversaries until attaining 3 consecutive years of certification with no limitations imposed.

For the Directorate of Metrology to certify a PMEL without an evaluation visit, the PMEL must meet the initial criterion of having been certified without limitations for the previous 3 years. The PMELs that do not require an evaluation visit during a particular year will be evaluated by evaluation data products. The products are PMEL evaluation documents laboratory operations questionnaires, (routing, and review of quality control reports) forms, and monthly laboratory quality control operation and environment status reports.

Upon completion of the evaluation, the Directorate of Metrology performs one of the following.

a. Issues a certificate of competency to the PMEL, indicating the PMEL is fully certified and the laboratory is considered to be competent to calibrate all PME within the limits of its responsibility.

b. Issues a restricted certificate indicating the PMEL will not calibrate PME in specified areas.

c. Does not certify the PMEL, in which case the PMEL will not calibrate any PME.

Information identifying the total measurement requirements of a specific Air Force system is compiled during the planning stages by the system contractor. This information is submitted to the Air Force in the form of a summary entitled "Calibration Requirements Summary (CRS)." The CRS identifies each and every measurement that must be supported on the operational system or equipment. Upon receipt of CRS data from the system contractor, the Directorate of Metrology conducts an analysis of (1) each measurement parameter listed and (2) the method of support being used. Inadequacies noted during this analysis are brought to the attention of appropriate Air Force activities with recommendations for correction. Complete system supportability is thus assured, and necessary actions are initiated to provide each supporting PMEL with the required calibration standards. The CRS data is then revised, condensed, and refined to complete the measurement link between the operational equipment and the NBS. The data, as refined by the Directorate of Metrology, is published in 33K or weapon/equipment system series TO *Calibration Measurement Summaries*.

In addition to the system support calibration requirements, which are generated as a result of the CRS, the Directorate of Metrology continuously studies measurement requirements versus available capability. These studies are directed toward upgrading the measurement capability within the USAF calibration system to meet needs of new systems and equipment.

The USAF calibration upgrading program for PMELs is aimed at obtaining optimum capabilities. Command certification on requests for assistance (which we discussed earlier) falls under this program, since command certification serves two purposes. Let us consider these two purposes.

(1) Command certification insures that all current resources (within using commands) are closely scrutinized to determine adequacy and/or corrective action necessary to update outmoded resources.

(2) The operating command requirements are reviewed by AFLC ALCs, which are solicited to determine if the technical capability for calibration of an item can be feasibly assigned to the base PMEL.

Exercises (098):

1. Which technical order covers the USAF calibration program?
2. Who establishes and maintains the highest echelon of calibration reference standards of measurement in the United States?
3. Why is the Naval Observatory tied into the Air Force calibration program?
4. If no calibration interval is given in the TO on an item of PME, what is the maximum interval that can be assigned?
5. Must all PME be calibrated on all ranges? Why?
6. If a PMEL has only the capability to partially calibrate an item, what should be done?
7. Briefly describe the goal of the USAF calibration upgrading program.

099. State the purpose of calibration forms and labels used most frequently in the PME lab.

Preparation and Use of Calibration Forms and Labels. Although several forms are used in the PMEL, we will cover only the ones you encounter most frequently.

PME Certification Label (AFTO Form 108). This label, shown in figure 6-2, is completed and affixed to standards and PME certified by the responsible calibrating work center except when an AFTO Form 394, PME Certification Label, is needed. Labels must not be removed or replaced except by persons authorized to perform calibration and certification. Alteration of labels is not

IDENTIFICATION NO. Q4500 / SH 0063	
AUTHORITY (I. O. NO.) 33K8-4-1-1 (S)	
SPECIAL	
Certified By 	DATE CALIBRATED 10 APRIL 80
	DATE DUE 7 OCT 80
Certified By	DATE CALIBRATED
	DATE DUE

PREVIOUS EDITION WILL BE USED

AFTO FORM 108 APR 77 PME CERTIFICATION

Figure 6-2. AFTO Form 108.

permitted. Laboratory supervisors or other duly authorized persons fill out this label in the following manner:

a. IDENTIFICATION NO. Enter the owning work-center code and the six-digit master ID number of the equipment being certified. AFLC activities will enter the owning work-center code and the five-digit PME ID number. Also enter "MOB" if the PME will be packed and stored for mobility. This block will be filled in by the PME user/owner if the PME is calibrated by an off-base PMEL and the PME inventories of the off-base PMEL and the PME user/owner do not have a common data base.

b. AUTHORITY. Enter the 33K, or 33L series calibration technical order number. If there is no 33K or 33L series technical order, enter the maintenance technical order number or special or local instruction source.

c. SPECIAL. Use this block for the following purposes:

(1) To indicate the accuracy to which the item was calibrated if the user of the item requests it or if the item was calibrated to less than the accuracy specified in the approved calibration procedure; e.g., percent accuracy: $\pm .03$ percent FS. In the case of multiple function equipment where it is not practical to list each function and accuracy, refer to paragraphs 5-11 through 5-13. If a 33K or 33L series technical order is not available, the supporting PMEL will compute the accuracy using the maintenance technical order and/or the manufacturer's handbook.

(2) To identify the basic function that was measured and the ranges or parameters certified; e.g., FUNCTION: 0-50 VAC. If it is more convenient the exceptions may be entered; e.g., FUNCTION: Except 0-500 VDC. No entry will be made if all functions and ranges were measured.

(3) To indicate calibration at specific points or values and/or to indicate a calibration correction chart has been prepared for the item. When the first application is being used, enter the value or points being certified. When the second application is being used, enter the form number of

the calibration data or correction chart; e.g., AFTO Form 249.

(4) Other information pertinent to the PME to which AFTO Form 108 is affixed.

d. CERTIFIED BY. The "K" stamp of the PMEL technician or the inspection stamp or initials of the calibrating technician of other performing work centers will be entered in this block.

e. DATE CALIBRATED. Enter the calendar date or Julian date the PME was calibrated. A postdate will be entered to coincide with the date that PME is picked up by or delivered to the customer at intervals less often than weekly. A postdate may also be entered to coincide with the deployment date for PME that is used to equip maintenance teams that are deployed to support off-base customers.

f. DATE DUE. Enter the day, month, and year, or the Julian date the equipment is due for calibration. This date is computed in accordance with AFM 66-267. In addition, enter "SCBU" (seldom used calibrate before use) for PME so designated. Enter "NPCR" (no periodic calibration required) for PME so designated. The calibration due date is not required for PME designated NPCR. Leave this block blank if the PME will be packed and stored for mobility. The calibration due date will be computed using the assigned calibration interval starting from the date the PME is removed from the mobility container for use.

g. Enter a red diagonal line across the entire AFTO Form 108 if the PME was calibrated to less than the accuracy or functional capabilities specified in the approved calibration procedure or to bring to the attention of the PME user that calibration data or a correction chart was prepared to supplement AFTO Form 108.

PME Certification Label (AFTO Form 394). This label, shown in figure 6-3, is completed in the manner described for an AFTO Form 108. It is used when the equipment is too small to accommodate an AFTO Form 108 or when the certification label must be displayed on the operational side or front of the unit. The calibrating technician prepares this label in the following manner:

a. ID. NO. Enter the owning work-center code and six digit master ID number of the equipment being certified. AFLC activities will enter the owning work-center code and the five-digit PME ID number. Also enter "MOB" if the PME will be packed and stored for mobility. This block will be filled in by the PME user/owner if the PME is calibrated by an off-base PMEL and the PME inventories of the off-base PMEL and the PME user/owner do not have a common data base.

b. SPECIAL. Use this block for the purposes described earlier (see item c under PME Certification Label-AFTO Form 108) as space permits.

	CERTIFIED BY	PME CERTIFICATION LABEL
	ID. NO. Q4500/SH2387	
	SPECIAL	
	DATE DUE 7 OCT 80	

AFTO FORM 394 MAR 77 PREVIOUS EDITION WILL BE USED

Figure 6-3. AFTO Form 394.

c. **DATE DUE.** Enter the day, month, and year, or the Julian date the equipment is due for calibration. This date is computed in accordance with AFM 66-267, Maintenance Data Collection System, Users Manual. In addition, enter "SCBU" for PME so designated. The calibration due date is not required for PME designated NPCR. Leave this block blank if the PME will be packed and stored for mobility. The calibration due date will be computed using the assigned calibration interval starting from the date the PME is removed from the mobility container for use.

d. **CERTIFIED BY.** Enter the "K" stamp, inspection stamp, or initials of the calibrating technician; and the day, month, and year, or the Julian date, the equipment was calibrated. The date may be entered in the left-hand margin. A postdate will be entered to coincide with the date that PME is picked up by or delivered to the customer at intervals less often than weekly. A postdate may also be entered to coincide with the deployment date for PME that is used to equip maintenance teams that are deployed to support off-base customers.

e. Enter a red diagonal line across the entire AFTO Form 394 if the PME was calibrated to less than the accuracy or functional capabilities specified in the approved calibration procedure or to bring to the attention of the PME user that

calibration data or a correction chart was prepared to supplement AFTO Form 394.

PME certification stamp. The certification stamp indicates that an item has been calibrated in accordance with TO 33K-1-100 by authorized personnel assigned to the PME laboratory. The use of "K" stamps by the PMEL technicians is mandatory. Stamps are serially numbered to identify the technician or supervisor and the activity to which he or she is assigned. The stamp is used only on those forms, tags, or labels described in TO 00-10-14 and AFR 66-1, Volume 5.

It is the responsibility of Quality Control to issue and control the stamps in accordance with AFR 66-1. Stamps are issued only to qualified personnel identified by the PMEL branch chief.

The "K" stamp must be as illustrated in figure 6-4. The use of a stamp with smaller or larger dimensions is optional provided it is dimensionally proportional and does not exceed the space available on AFTO Forms 108 and 394. The "K" stamps are obtained through local purchase.

PME Calibration Data (AFTO Form 249). This form, shown in figure 6-5, is completed for PME certified at other than the full range if requested by the using organization or,



(ACTUAL SIZE)

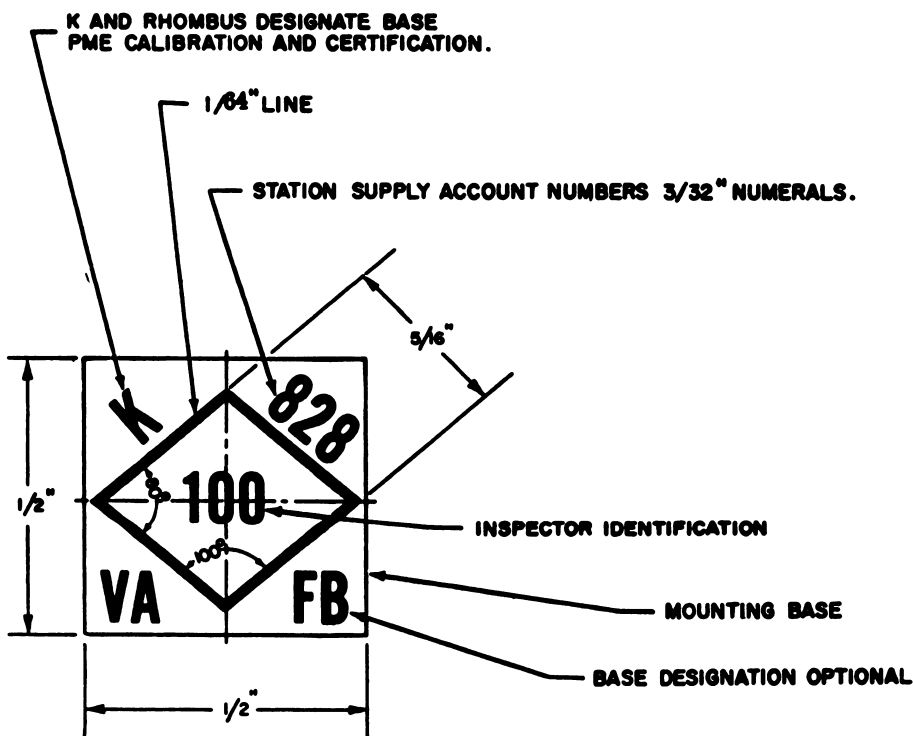

(ENLARGED 4 TIMES ACTUAL SIZE)

Figure 6-4. PME certification stamp.

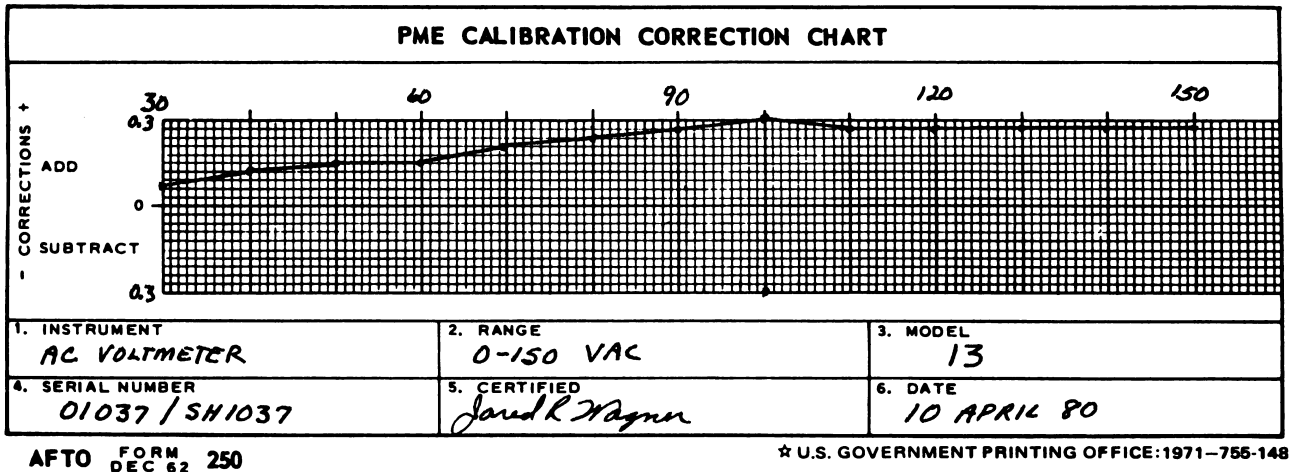

Figure 6-6. AFTO Form 250.

Precision Measurement Equipment Record (AFTO Form 136). This record, shown in figure 6-7, is maintained by the PMEL or other performing work center when automated scheduling reports are not available. The AFTO Form 136 may also be used for historical purposes. When used, the record is completed on each item of PME serviced by the laboratory to provide a permanent record and control system. If classified information is entered, action must be taken in accordance with DOD 5200.1-R/AFR 205-1, Information Security Program Regulation to safeguard this information. The record is filled out by the production scheduler or technician as follows:

- a. Place a red tab in the proper month block to indicate the month the equipment is due for calibration. Insert a green tab in the proper month block to indicate the month the equipment was calibrated. On those items possessing a 1-year calibration interval, only the tab indicating the month the equipment is due for calibration is used.
- b. FILE DESIGNATOR. Enter the type, model, or part number and item serial number. This entry designates the file position when items are filed by alphanumeric sequence by part number and serial number.
- c. NOMENCLATURE. Enter the nomenclature of the item being calibrated.
- d. ACTIVITY, LOCATION AND TELEPHONE NO. Enter the name and complete address of the activity submitting the item for calibration.
- e. TYPE, MODEL, PART OR SERIAL NO. Enter the appropriate military or commercial type or model designation and serial number of the item being calibrated.
- f. MANUFACTURER. Enter the name of the manufacturer of the item being calibrated.
- g. TOLERANCES/ABSOLUTE VALUE. Enter the specific tolerances or absolute value to which the calibrated item has been certified.
- h. STOCK NO. Enter the Federal stock number assigned to the item being calibrated.
- i. DATA REFERENCE. Enter the appropriate technical order number or special instruction source that established the calibration procedure for the item being calibrated.

- j. CALIBRATION INTERVAL. Enter the calibration interval.
- k. DATE. Enter the day, month, and year calibration was done.
- l. STATUS. Enter the status or condition of the item when it was received for calibration.
- m. TECHNICIAN. Enter the name of the calibrating technician.

Request for Limited/Special Calibration (AFTO Form 163). This form, shown in figure 6-8, will be filled in by the PME user/owner and submitted to the performing work center for PME that is to receive a limited calibration or for PME that is to be exempted from periodic calibration. A copy will be filed by the performing work center and the user/owner. This form is not required if the performing work center is also the PME user/owner.

AFTO Form 163 is filled in as follows:

- a. Block 1, PART/MODEL No. Enter the manufacturer's part/model number as shown in TO 33K-1-100, MDC equipment inventory, maintenance technical order, or manufacturer's handbook.
- b. BLOCK 2, NOMENCLATURE. Enter the nomenclature as shown in TO 33K-1-100, stock list, maintenance technical order, or manufacturer's handbook.
- c. Block 3, IDENTIFICATION No. Enter the MDC master ID number if the equipment is included in the MDC equipment inventory. Otherwise, enter the serial number.
- d. Block 4, LIMITED CALIBRATION. Check this block if the PME is to be calibrated to less than the accuracy or functional capabilities specified in the approved calibration procedure. The specific functions, ranges, or parameters that are to be certified will be identified in block 7, REMARKS.
- e. Block 5, DESIGNATE NPCR. Check this block if the PME is to be designated NPCR (TO 33K-1-100, para 3-2).
- f. Block 6, DESIGNATE SCBU. Check this block if the PME is to be designated SCBU (TO 33K-1-100, para 3-2).
- g. Block 7, REMARKS. Enter the specific functions, ranges, or parameters that are to be certified if the PME is to be calibrated to less than the accuracy or functional

capabilities specified in the approved calibration procedure (limited calibration). The justification for designating PME as NPCR or SCBU will also be entered in this block. Other information may be entered that is pertinent to the limited/special calibration request.

h. Block 8, OWNER/USER SIGNATURE. Enter the signature of the owner/user of the equipment.

i. Block 9, OWNING ORG. Enter the owning work-center code as used on the MDC equipment inventory.

j. Block 10, EXTENSION. Enter the telephone extension number of the person that initiated the form.

k. Block 11, DATE. Enter the date (day-month-year) the form was initiated.

AFTO Forms 163 must be reviewed at least annually by the organization that owns the PME to determine if a change in designation is warranted. The review is attested to in block 7 with annotation "REVIEWED," the date, and signature of the person who conducted the review. The performing work center must be informed of any changes to the designation or of equipment turn-ins.

The initial AFTO Form 163 remains in effect for the duration of the limited/special calibration. An AFTO Form 163 is initiated only if a change to the limited/special calibration occurs.

AFTO Form 163 is destroyed when it no longer serves a useful purpose.

Placement of certification labels. Certification labels are affixed to a clean surface in a conspicuous, clear area on the equipment. On small items, the label may be affixed to a plain manila tag and tied to the equipment. Items that will not allow affixing of the label, such as optical flats and gage blocks, may have the label affixed to their container.

Alternate methods to identify certification. Where circumstances dictate, identification of PME certification is performed as described in the following paragraphs.

On complex PME, such as test stands or checkout consoles, one certification label for the end-item will suffice for all items that are an integral part of it. An item is considered an integral part if it must be calibrated as a part of the stand or console. Integral items are identified by the identification number that is entered on the certification label for the stand or console. That equipment normally removed from the end-item for calibration is not an integral part and will have individual certification labels. Certification labels are grouped on the end-item remote from the component with a number for identification purposes placed on the component and the certification label.

On PME where the certification label cannot be affixed or utilized, one of the following two methods provides a convenient and positive method of indicating certification:

(1) Place a strip of embossing tape, annotated with the day, month, and year recalibration and certification are due, on the equipment.

(2) Where certification of PME cannot be indicated by using tape, tags, or labels because of design, usage, oils, grease, or other environmental conditions, mark the equipment with paint of the appropriate color.

Use the following colors when tapes or paints are used to indicate the month in which the item is due for calibration. Items with calibration intervals of 4, 8, or 12 months must be

further identified as to the specific month or year calibration is due.

Color	Month Calibration Due
Blue	January—May—September
Red	February—June—October
Black	March—July—November
Yellow	April—August—December
Green	Seldom used items—calibrate before use
White	No calibration required
Brown	No periodic calibration required

No Calibration Required (AFTO Form 256). This label, shown in figure 6-9, is affixed to those items of PME listed as NCR in a calibration measurement summary (CMS) or in TO 33K-1-100. This label is validated by stamping it with the "K" stamp or an inspection stamp, or by having the owner or user of the PME initial the label.

Notice Certification Void When Seal is Broken (AFTO Form 255). This label, shown in figure 6-10, may be applied at the option of the responsible performing work center to standards and PME having adjustments that affect calibration. When the option to use the label is exercised, it is validated by the "K" stamp or the initials of the responsible technician. It is applied in such a manner that any attempt to repair or adjust the equipment results in breaking the seal. If the seal is broken accidentally or broken to perform organizational maintenance, such as cleaning or replacing fuses, pilot lights, batteries, or other minor hardware items, an identification tag is attached noting the reason, date, and operator's signature. Recertification is done if calibration accuracy is not in question. Alternate methods may be used at the option of the responsible calibrating work center to seal PME if the AFTO Form 255 cannot be applied satisfactorily.

Exercises (099):

1. What is the purpose of AFTO Form 108?
2. What type of PME is an AFTO Form 255 attached to?
3. When is an AFTO Form 256 attached to items of equipment?
4. What is the purpose of the AFTO Form 136?

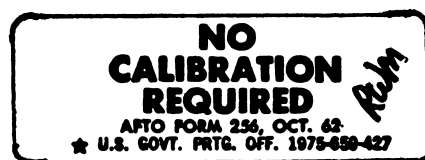

Figure 6-9. AFTO Form 256.



Figure 6-10. AFTO Form 255.

5. When do you use the following AFTO forms?
 - a. AFTO Form 249, PME Calibration Data.
 - b. AFTO Form 250, Calibration Correction Chart.
6. When making up a Calibration Correction Chart, what does the horizontal centerline represent?
7. Who is authorized to remove and/or replace calibration labels on precision measuring equipment?
8. What information is put in the AUTHORITY block of the AFTO Form 108?
9. Where would you find information or guidance to complete the DATE DUE block on the AFTO Form 108?
10. When will a red diagonal line be entered across the entire AFTO Form 108?
11. When would an AFTO Form 394 be used?
12. What information goes in the ERROR block on the AFTO Form 249?
13. For what is the AFTO Form 163 used?
14. Who is responsible for completing the AFTO Form 163?

6-2. Laboratory Practices

One of the major aspects of management in a PMEL is to instill the philosophy that the working area is a laboratory, as opposed to a maintenance shop. Personnel are apt to perform higher quality work when surrounded by laboratory conditions.

100. Resolve issues and solve problems common to laboratory management and operation, and identify particular persons with their laboratory responsibilities.

Managerial Tasks. The following actions by laboratory managers should produce desirable results:

- a. Maintain the PMEL operation and facilities in a condition that will insure mission accomplishment.
- b. Insure management procedures conform with the requirements specified in TO 00-20-14 and AFR 66-1.
- c. Submit reports accurately and on time.
- d. Insure items of PME are calibrated and certified in accordance with the requirements of TO 00-20-14 and TO 33K-1-100.
- e. Establish and maintain a quality assurance program in compliance with AFR 66-1.
- f. Insure that locally imposed measurement restrictions are implemented and documented in a log when the facility environment deviates from the tolerances specified for the laboratory.
- g. Establish a training program to achieve the maximum technical capabilities of assigned personnel.
- h. Initiate and maintain an effective safety program.
- i. Insure that items of PME identified as being beyond the PMEL's capability to repair or calibrate are properly processed in accordance with TOs 00-25-107, 33A1-1-10, 33-1-27, AFM 67-1, and AFM 66-267.
- j. PMEL managers should realize that many tasks in the PMEL do not require the skills of a PME technician. When practical, clerical, supply, and equipment cleaning duties are performed by personnel of appropriate skills, other than the PME technician.
- k. Items of PME that are fragile or subject to environmental damage and require support from higher echelon laboratories are normally delivered and returned by courier. A PME technician should not be used for courier duty unless he or she is to receive specialized PME training at the higher echelon laboratory.
- l. Coordinate calibration support with hospital maintenance personnel.
- m. Maintain optimum cleanliness. No eating, drinking, or smoking will be permitted in the calibration repair areas.
- n. Locate proper fire extinguishers in all areas.
- o. Make certain the calibration and repair area of the laboratory is not used for office space for supervisory or clerical personnel.
- p. Establish a system to identify and control locally manufactured test fixtures.
- q. Take action in accordance with AFR 66-1 regarding late delivery of PME for scheduled calibration.

Quality Control Program. Commanders insure that the base quality control program includes measures for quality

assurance of precision measuring equipment. In accordance with AFR 66-1, the responsibility for determination of quality maintenance production is assigned to maintenance supervisory personnel.

Production inspection within the PMEL is accomplished by quality control augmentees or PMEL technicians assigned to the Quality Control Function. Highly qualified PMEL personnel will be designated by the Deputy Commander for Maintenance (DCM) control inspectors. The program requires the use of the following:

- a. Sampling plans to determine quality of maintenance and accuracy of parameters.
- b. Inspection of physical condition, including completeness, paint, and general serviceability.
- c. Verification of TCTO accomplishment.
- d. Checks to determine completeness and accuracy of documentation.
- e. Inspections of in-process work and equipment at critical stages of work process.
- f. Periodic inspections of a representative number of items immediately after calibration and certification have been accomplished.

The base quality control program should include the inspection of stations, shop areas, and storage areas to determine if PME is receiving proper care, handling, and use. Personnel within the 324X0 career field, or equivalently qualified personnel, should be members of the inspection team. Furthermore, all findings of the inspection team should be officially documented.

Facilities. The criteria for facilities also come under the broad heading of management. Facilities cover such areas as power requirement, environmental controls, air filtration, special operating conditions, and laboratory layout and space utilization. Perhaps the most important consideration in this area relates to temperature and humidity. To help insure that your measurements meet established accuracy requirements, you should be certain that your laboratory environmental conditions are as follows:

a. Type II (all) and type III PMEL calibration/repair areas:

- (1) Design temperature: 73° F. dry bulb.
- (2) Temperature tolerance: $\pm 1^\circ$ F. dry bulb.
- (3) Temperature change: Maximum of 1° F. in any 1-hour period.
- (4) Design humidity: 45% RH.
- (5) Humidity tolerance: +5%, -25% (20-50% RH).

b. Type IIA and type IIC PMEL precision dimensional areas:

- (1) Design temperature: 68° F. dry bulb.
- (2) Temperature tolerance: $\pm 0.5^\circ$ F. dry bulb.
- (3) Design humidity: 40% RH.
- (4) Humidity tolerance: +5%, -20% (20-45% RH).

Calibration Standards Packages. Calibration standards measurement area packages consist of standards, PME, and auxiliary items that provide a measurement capability that is traceable to the next higher calibration echelon through Base Reference Standards. Items designated for calibration at higher echelons do not require command certification.

Items in these packages listed in Part A, Section A, of TA 734, are distributed under procedures of Project Pacer Stop, Code 220. The transfer or turn-in of items listed in Part A, Section A, of TA 734, must be approved by the Aerospace Guidance and Metrology Center (AGMC)/MLTP. Federal stock numbers are not included in these lists because of stock list changes and timing difficulties; however, model numbers can be easily cross-referenced to TA 734. The 33K TOs outline the methods and equipment required for calibration of items other than the standards designated for calibration at AGMC.

Series 33K-2-11 TOs are published for each standard in the package that is calibrated by AGMC. These TOs contain instructions and information relative to the exchange or calibration support procedure.

The majority of items in the calibration standards package have either been distributed or are on procurement. The proposed initial distribution time period during which each item or package will be distributed to PMELs is noted. During this interval each PMEL is notified when a package, partial package, or item is available for courier pickup or for shipment in accordance with Project Pacer Stop. This notification indicates only that the overall PMEL self-sufficiency program is being improved in a measurement area. If a specific PMEL is of the type that has no workload or anticipates no workload in the measurement area involved, the item should not be requisitioned. When a package is complete, the Base Reference Standards for support of the package are exchanged or supported directly from the echelon indicated, normally AGMC. During the initial distribution interval or until a given PMEL has a complete capability in each measurement area, the base continues to receive support from its geographic AMA.

One purpose in distributing such items or packages is to reduce requirements for command certification for higher echelon calibration service. Therefore, when such a new item or package is received at a BPMEL, all requirements for command certification in the measurement area involved are reviewed. If the item or package can be used to calibrate any item on the command certification list, such items are deleted immediately and calibration is performed at the BPMEL. The BPMEL notifies the AMAs of items that are deleted from the list. If an item cannot be calibrated at the echelon indicated, because initial distribution of the item or package required has not been received, a request for command certification for services is authorized.

The calibration standards measurement packages form the nucleus of the entire calibration program. Particular attention should be given to maintaining accuracy and integrity of these standards. Should any major maintenance (other than tube, fuse, and battery replacement) be required, contact the Directorate of Metrology, AGMC, for instructions. Normally, a new item is exchanged for the repairable item.

Working Standards List. The working standards list, pointed out in figure 6-11, includes standards that are distributed to the PMELs for special or routine calibration of PME; and when working standards are used in accordance with applicable 33K TOs, these standards provide a media to transfer calibration from the calibration standards package to PME, as indicated in figure 6-11.

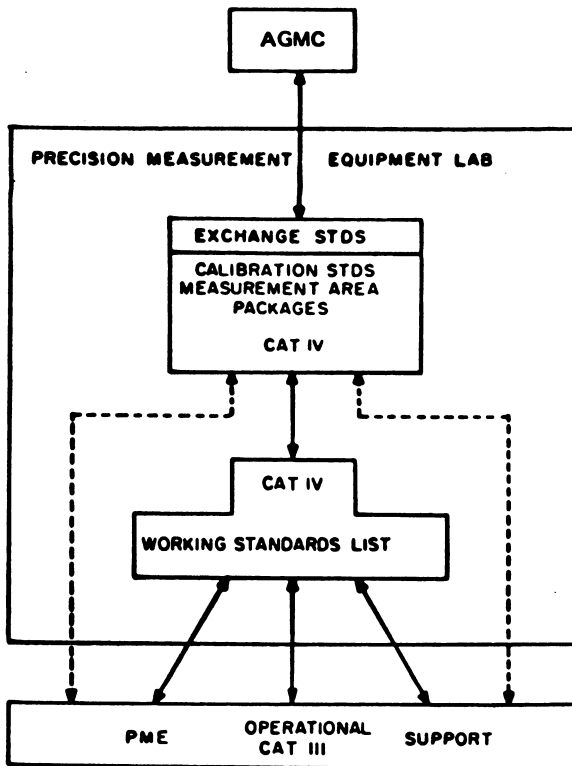

Figure 6-11. PME routing.

Items in the working standards list are normally supportable at BPME level by the calibration standards measurement area package. In some instances, items listed in the working standards list may be used in conjunction with the calibration standards measurement area package to calibrate an item. The calibration echelon is indicated for working standards that cannot be supported at the BPME using the calibration standards measurement area package or a combination of the package and working standards.

Working standards are normally listed in TA 734 in other than Part A, Section A, and have been or will be distributed through normal supply channels as authorized by the local BEMO. The 33K TOs outline the method and equipment required to calibrate the items.

Listing of items as working standards or quoting of TOs in no way provides authorization for the items. Validation of requirements for the equipment items must be fully supported by need and workload to the local BEMO. Since as a general rule the calibration standards measurement package will calibrate the working standards listed (even though TO 33K may call for other items), the calibration standards measurement package for a given area may be considered as a substitute for any or all of the working standards listed under the package. Therefore, there will be no procurement of any working standards for PMEL applications (TA 734 authorizations) unless it can be substantiated that the workload is such that the calibration standards measurement package for a given area is used to the fullest possible extent. An exception to this would be scopes, meters, frequency counters, and their related accessories.

Conversely, PME that can be calibrated using working standards should be so calibrated in order to not overload use of the calibration standards measurement area package. In short, optimum use of all measurement equipment must be accomplished. The working standards lists are not intended to include all such equipment at all PMELs. The lists are the major Category IV working standards called for in TO 33Ks primarily as a result of calibrations requirements summaries. The majority of Category III PME scheduled through the PMEL can be calibrated by using the items listed or by using a combination of the working standards and the calibration standards measurement area packages. If an item cannot be calibrated at the echelon indicated because distribution of an item or package required has not been received, a request for command certification for services is authorized. Command certification is not required for working standards designed for higher echelon calibration.

Exercises (100):

1. What is one of the prime responsibilities of a PMEL manager regarding the overall working area?
2. When is it permissible to use a PME technician for courier duty?
3. If an item that is part of the calibration standards package becomes excess to your needs, what must you do before the item can be turned in?
4. What should you do when you receive a new item that becomes part of the calibration standards package?
5. If an item is listed in TA 734, does this mean that the item will be automatically issued to the BPME? Why?
6. What temperature must be maintained in the calibration and repair areas of type II and III PMELs?
7. Who designates PMEL personnel as quality control inspectors?

6-3. Supervision

As a specialist, you contribute to the mission of your organization by effectively managing your individual

activities. However, you are moving toward a greater responsibility.

Eventually you may become a supervisor and accordingly will assume more responsibilities. Responsibilities include elements such as:

- a. Planning and coordinating work assignments.
- b. Conducting inspections.
- c. Analyzing and preparing reports.
- d. Justifying personnel and equipment.
- e. Exercising proper care of Air Force equipment.
- f. Resolving technical problems encountered by other personnel.
- g. Participating in the Graduate Evaluation Program.
- h. Conducting and managing on-the-job training.

You, as a specialist, have a certain amount of responsibility for the last four elements.

101. Define pecuniary liability and identify related procedures with pecuniary liability situations.

Responsibility for Public Property. Property responsibility is the obligation of each individual for the proper care of property belonging to the Air Force, whether or not such property has been issued to the person or the unit. Such responsibility includes pecuniary liability. Pecuniary liability means that a person has to make good (pay for) the loss, damage, or destruction of property resulting from his or her maladministration or negligence in the use, care, custody, or safeguarding of such property from causes other than fair wear and tear.

If you have acquired possession of Government property, then you have custodial responsibility for it. You are personally responsible for such property if it is issued for your official or personal use, whether or not you have signed a receipt for it. You are also personally responsible for any property under your direct control for storage, use, custody, or safeguarding. "Finders, keepers" may apply in some circumstances, but not to Government property. If you find Government property that has apparently been lost, stolen, or abandoned, you must assume custodial responsibility for it and protect or care for it until it can be returned to the proper authorities.

Personnel may be relieved of responsibility for a particular piece of property in a number of ways, depending upon the circumstances. Property may be turned back to base supply as excess to the unit's needs. Other items may be transferred from the responsibility of one person or organization to another. Still other items may be damaged or lost through carelessness of the one having custody, in which case this person may be liable and have to pay for them by deductions from his or her paycheck. Any one of several procedures may be followed if pecuniary liability is involved. Common procedures involve the Cash Collection Voucher, the Statement of Charges, and the Report of Survey.

When pecuniary liability is admitted, the least troublesome way to settle a monetary obligation is to pay cash. The Cash Collection Voucher is used to reimburse the Government in cash.

If airmen or civilian employees admit liability but do not have the money to pay cash for property damaged or lost, DD

Form 362, Statement of Charges for Government Property Lost, Damaged, or Destroyed, is used. If an officer admits pecuniary liability and cannot pay in cash, DD Form 114, Military Pay Order, is used, which authorizes deduction from a person's paycheck. Note that when either the Cash Collection Voucher or the Statement of Charges is used, the amounts involved must be less than \$500. If \$500 or more, then another form is employed, as will be explained next.

Whenever an individual will not admit pecuniary liability or when the amount involved is \$500 or more, a Report of Survey must be prepared. Two officers are directly concerned in processing a Report of Survey. They are the appointing authority and the investigating officer. The appointing authority is a commander or other officer having jurisdiction over the individual who has custodial responsibility for the property in question. The appointing authority appoints a survey officer (the investigating officer) whose duty it is to make a detailed and impartial investigation (survey) of the circumstances connected with the loss, damage, or destruction of the property described on the Report of Survey. A survey officer is not necessarily appointed in every instance. When circumstances do not appear to warrant such a step, the appointing authority may make his or her own recommendations and forward the Report of Survey to the base commander for review and approval. As a result of the findings, the person responsible for the custody of the property in question may or may not be required to pay for it. The member will be relieved of the responsibility without reimbursing the Air Force if the Report of Survey is approved. If the authorities decide from the evidence that the responsible individual was grossly negligent in caring for the property involved, then he or she has to reimburse the Government by paying in cash (the Cash Collection Voucher) or authorizing a pay deduction (Statement of Charges).

Exercises (101):

1. Define pecuniary liability.
2. What forms or reports are used if pecuniary liability is involved?
3. What form is used if one admits liability but does not have the money to pay cash for the lost or damaged property?
4. When is a Report of Survey prepared?

102. Identify USAF supply documents and supply organizations, and cite the type of information needed to prepare special requisitions and issue and turn-in forms.

Supply Administration. Many thousands of items of spare parts, special tools, maintenance equipment, pencils, paper clips, etc., are required in the accomplishment of the Air Force mission. The cost runs into billions of dollars. This property is stored, issued, and reissued, or shipped—a cycle that may be repeated several times before an item is no longer usable and is sold for scrap. All personnel in the Air Force must treat these properties as if they were their own. This applies to officers, airmen, and civilians alike. However, to avoid wastefulness and carelessness, definite responsibility must be assigned to assure that Government property is adequately safeguarded and efficiently used. As a supervisor, this will definitely be one of your primary responsibilities.

Issue and turn-in forms. For requesting supplies, you most likely will find local and Air Force forms used. For this reason, we do not discuss the form numbers. We list some of the information that is required by them. Keep in mind that these forms have a dual purpose. They are used for either issue or turn-in of equipment or supplies. Turn-in is appropriate for excess or unserviceable property. Your unit supply custodian indicates which action is requested. The following information goes on the form:

- a. Date of request and unit designation.
- b. Unit supply request number (for identification or followup action).
- c. Name and telephone number of the unit supply custodian.
- d. Equipment stock number or part number, and name or description of the item.
- e. Justification of request. This will include citing the allowance documents applicable and a brief statement of circumstances.
- f. Quantity required.
- g. Certificate by the commander or his or her representative that the requirement is valid.

Special requisitions. During the course of your duties, you may be required to order parts that are not stocked by the base supply office (BASO). Items that are not identified by the Air Force supply system must be special ordered. To order items on which BASO has no information, a special requisition must be submitted. The special requisition must include a description of the item and the manufacturer's name and part number, if possible. If you know this information about the item of equipment, refer to BASO for help in preparing the special requisition.

Exercises (102):

1. What information is required for a special requisition?

2. Which official USAF document must be quoted in the request for issue of a specific item of equipment?

3. What type information must be included on Air Force issue and turn-in forms?

103. State the reason a supervisor coordinates work with other shops and name the section in maintenance primarily responsible for coordination.

Coordination. Today's Air Force is made up of people with many AFSCs. Each of them is trained to do work in a certain area of aircraft maintenance. To name a few, there are specialists in aircraft electrical, weapons, hydraulic, engine, and fuel systems, plus many others, as well as your own.

During an inspection, many specialists/mechanics are required to perform work on the aircraft. Imagine the confusion if all of these people attempt to complete their required work at the same time. To avoid this and still accomplish the work in a timely manner, coordination with the other working shops is required. The coordination is usually done by Job Control. They are the people who schedule people, equipment, aircraft, and jobs.

Occasionally, in order to accomplish a specific task, you may require an assist from a technician who operates equipment in another shop. First, check the job, and then, through Job Control, arrange to have the needed technician dispatched from the user's shop.

As a supervisor, you spend many hours in one or another phase of coordinating. Training schedules, work programs, and assigning workers to jobs and shifts all require coordination in order to result in a well-balanced, smoothly operating organization.

Exercises (103):

1. Identify the one central agency primarily tasked with coordination in maintenance organizations.
2. Why is a large portion of a supervisor's time spent in coordinating actions?

104. State the reasons and procedures for planning and scheduling work assignments and priorities.

Planning and Scheduling Work Assignments and Priorities. As the supervisor, you must run a shop that fully supports the mission of the base. The way your shop operates to accomplish the mission is the result of your decisions. Your decisions are affected by the size and shape of the shop facility, workload, capabilities of your people, type of

equipment maintained, type of supply support, or to sum it up, your entire repair capability.

As task requirements arise, you must plan and schedule work assignments and set priorities. When planning to meet your objectives, check your resources (manpower and equipment).

Manpower is concerned with numbers as well as qualifications of personnel. For example, do not use 3-level personnel for difficult tasks and 7-level personnel for simple ones. Choose the right airman for the job.

Equipment also is very important. You cannot complete a task without the proper tools. Past workloads help you in planning your manpower and equipment for best utilization.

When planning an operation, consider scheduling. For example, you may have to schedule the use of test equipment among the specialists/technicians within the PME laboratory. Also, schedules must be planned for chow, shift work, etc.

Always assign priorities when planning and scheduling. Your primary concern is to support the main purpose of your unit and to insure proper operation of the PME laboratory. When setting priorities, schedule your personnel according to daily commitments.

With the proper planning, scheduling, and setting of priorities, you, as a supervisor, will get the most out of your available resources. Of course, you may need to refine your schedule; but these changes can be made at the appropriate time. One important consideration occurring each year is annual leave. Remember, the priorities of the PME laboratory must be met. For example, you may have only two people qualified to work on the AN/UPM141 radar test sets. If both want to take 30 days leave at the same time, you will have to make plans to cover the situation. The following alternatives exist—you may train another individual for the job, deny leave to one of the trained persons, or work out a compromise between the two trained people.

Other items to consider in planning are the skill levels and number of people required for certain jobs. Also, you need more than the minimum of required qualified personnel in case of an emergency. If such conditions arise, qualified personnel are needed to fill in. All personnel must understand the workload to facilitate planning and scheduling.

After your plans are made, if necessary, coordinate with other sections concerning equipment or laboratory assistance. After you schedule the work, monitor its progress to insure the success of your program.

Exercises (104):

1. What should be considered when task requirements arise?
2. Describe two resources that must be considered when we plan an operation.

3. Why is scheduling so important?

4. Why are priorities set?

105. State requirements for assigning personnel to maintenance and repair work.

Assigning Personnel to Tasks. You know by now that all of our tasks are not always the same, nor is everyone equally trained in all of the areas of responsibility. Therefore, as work orders are received and jobs assigned, carefully plan the assignment of workers. Assign a specialist or technician that can accomplish the task without much trouble. Usually, we think of the 7-level technician as the most qualified person to accomplish any task. However, this is not true in every case. For example, a 3-level specialist who has been working with microwave systems may be more qualified to work on a new radar test set than a 7-level technician whose experience has been exclusively in the dimensional area.

Besides job knowledge, consider the many other areas concerning job assignments. There are schedules to meet and a priority system which governs duty assignments. Very often this causes a shift of people from one job to another. Prevent doing this as much as possible, but, again, remember the shop priorities. For example, when you have a high priority job, place the lowest priority job (where qualified technicians are working) in "hold." Once you handle the emergency, the regular schedule can be resumed.

Exercises (105):

1. Should you always select a 7-level technician over a 3-level specialist for a complicated task? Explain.
2. Differentiate between what is meant by job knowledge and skill level when planning to assign personnel to tasks.
3. Besides job knowledge and skill level, what other important factor is considered when assigning people to an emergency work order?

106. State the supervisory responsibilities necessary to assure that personnel meet required inspection and maintenance standards, and cite the proper supervisory response in given situations.

Supervision of Inspection and Maintenance Activities. The performance of inspection, maintenance, and repair activities is a primary responsibility of the PME

specialist/technician. Successful accomplishment of these activities requires appropriate and adequate supervision, especially when new or inexperienced personnel are involved.

Supervisory responsibilities. In supervising airmen who are performing inspection, maintenance, and repair functions, the supervisor must assure that the airmen follow correct procedures and use the proper tools and equipment to perform each task. Assurance is necessary that workers take proper care of, and correctly handle and operate, intricate equipment, such as test sets and consoles. If the airmen are inexperienced at performing any part of an assigned task, the supervisor should check frequently to insure that the job is being done properly. When help or advice is needed on any step of the procedure, the supervisor should not hesitate to assist as necessary.

Supervision of maintenance activities includes establishment of the requirements for the necessary equipment, tools, and spare parts. The supervisor must insure that the necessary equipment and tools are available when the specialists/technicians need them. In most cases, the workers have the necessary tools in their toolkits. However, some tasks require the use of special tools, such as a torque wrench for mounting bolts. If a special tool is required in a worker's toolkit, the supervisor must assure that one is available if needed to do the job as specified in the proper TO. In short, both the supervisor and the workers must know which items of equipment, tools, and spare parts are needed to perform a job and how to obtain them.

Responsibilities of the PMEL branch chief are outlined in AFM 66-1. The branch chief must:

a. Insure the proper operation and maintenance of the highest echelon measurement standards assigned to the laboratory.

b. Insure the calibration and repair support for PME that is designated as a PMEL responsibility in TO 33K-1-100 or applicable calibration measurement summary for the host, tenant, and off-base supported activities, including Federal agencies, contractors, and security assistance program countries with established support agreements.

c. Implement the PMEL quality assurance program described earlier in this text.

d. Establish a customer relations program that includes periodic visits to each activity supported by the PMEL to render technical assistance and advice on PME matters.

e. Use the guidelines of AFR 66-1, TO 00-20-14, TO 33K-1-100, AFR 74-2, and Air Force 88-series directives to insure that the PMEL operation and facilities warrant certification.

f. Initiate action to correct any deficiencies that may affect PMEL certification.

g. Establish visitor access and control procedures.

h. Insure proper use of calibration forms and labels, in accordance with TO 00-20-14, on PME processed by the laboratory.

i. Establish a program to monitor current TCTO compliance on all PME entering the laboratory.

Review of work quality. The supervisor must assure the specialists or technicians have done the job completely and satisfactorily. If a specialist has very little experience on the

task, his or her work must be checked thoroughly. There are at least two good reasons for a thorough check. First, the equipment that has been worked on must operate properly for the success of the mission; and it must be in safe operating condition. Second, inspection of completed work may be turned into an excellent learning device for the airman in training. Your method or technique of reviewing completed work determines the inspection's usefulness as a teaching device. Where is a better place for the trainee to learn than on the equipment?

Reviewing a completed assignment requires a considerable amount of skill and tact, as well as a thorough understanding of the job. As you talk to workers, stress both the strong and weak points of the work each person has done. Praise work that has been performed skillfully, but do not tolerate substandard work. Avoid criticism, sarcasm, or personal references, since these comments may cut deeper than you realize and leave the worker with a strong feeling of dislike for you. In brief, don't just use words, but demonstrate the correct procedures and give workers the opportunity to correct their faults.

There is one other thing you should do. Check job progression. Don't wait until the job is finished. A job sometimes has to be redone if an error is found before the job is completed. Failure to check job progression may cause loss of time and work output. It can also lead to hard feelings and loss of ambition on the part of individuals who find their efforts wasted because they were requested to do the same job over.

Exercises (106):

1. What should a supervisor do to assure that a job is being done correctly when relatively new or inexperienced workers are assigned to perform the task?
2. Who must assure that a worker's equipment and tools are available to perform an assigned task?
3. State two reasons why a supervisor should thoroughly inspect a completed work assignment.
4. Explain what corrective and/or preventive action the supervisor should take in the following situation:

The supervisor finds on inspection that a task has been done in an outstanding manner except that the holddown mount bolts are safety-wired backwards.

5. Why should you check a job several times while the work is being done rather than wait until the task is completed?

107. State the use and purpose of maintenance and inspection reports and charts.

Maintenance and Inspection Reports and Charts. Maintenance and inspection reports are very important in the life of a supervisor. A supervisor has access to a variety of daily and monthly maintenance reports that can be used to analyze maintenance activities and determine work patterns of the personnel. These reports provide supervisors with the information they need to determine how each worker is employed and how much of a worker's time is spent on each maintenance activity. Maintenance reports are prepared from information that is supplied on maintenance forms. In addition to maintenance reports, the squadron analysis section keeps a complete record of each writeup that is received from the aircraft crewmembers and ground crews. This information is also supplied by maintenance forms. Experienced supervisors have discovered that it is always a good practice to check the past history of equipment. Remember that each technician does not work on every job assigned to the PME laboratory.

Charts and graphs also are useful to the supervisor in comparing several items of information, such as time versus failures. However, charts and graphs do have limitations. They must not be too complicated to read. A chart such as a training chart can have many training operations indicated and still be readable. However, if the supervisor starts adding leave schedules, annual shots, and other items of personnel information, then the training cannot be determined quickly. Graphs are more limited than charts. For example, a graph containing more than five items of information is considered to be difficult to read and understand.

Exercises (107):

1. Why are maintenance and inspection reports and charts important to the supervisor?
2. Why would the supervisor be interested in the time taken to accomplish a task as shown on maintenance reports?
3. How many separate graphs would normally be used to show 11 items?

108. State the reason for establishing performance standards.

Performance Standards. Supervisors must see that the personnel under their supervision carry out the responsibilities and perform the duties necessary to accomplish the unit mission. Before personnel can be expected to fulfill these requirements, they must know their responsibilities and be familiar with applicable work methods and procedures. In addition, they must know to what degree of accuracy and completeness each duty or task must be performed.

The supervisor supplies the necessary guidance in the form of work methods, controls, and performance standards. The correct and most efficient way to perform these various duties and tasks is established as a work method. Regulation of work assignments, schedules, and methods is accomplished through established work controls. Success or failure of the work methods and controls is evaluated or measured by means of performance standards. Only when established standards are met can the supervisor consider that the workers are fully accepting their responsibilities and accomplishing the duties required of their assignments.

The performance standards for calibration of test equipment within a PME laboratory are established in the TO 33K or 33L series technical orders calibration procedures. These technical orders outline and prescribe correct and required procedures for performing each task. For even the simplest task, the supervisor must assure that the worker has the necessary technical data. The supervisor must enforce the standards for proper care and handling of test equipment, cleaning shop areas, safety around the PME laboratory, and proper dress and grooming, as outlined in AFM 35-10, *Dress and Personal Appearance of Air Force Personnel*. To assure that personnel are meeting required standards, daily checks by the supervisor of all work activities are essential.

In the event an area is falling below standard, the supervisor should set up a program to get it back up to standard quickly. You noticed that we used the word quickly, which is important to the supervisor. If standards are allowed to drop awhile because of other problems, substandard conditions may appear to be standard. The maintenance of standards is not only the responsibility of the supervisor, but everyone assigned to the organization. Thus, the supervisor looks to each subordinate worker to help in maintaining standards. If established standards are to be met, every worker must do his or her share of the work.

Exercises (108):

1. What important management tool is required in support of established work methods to provide quality control of a supervisor's operations? Explain its purpose.
2. Why should a supervisor immediately correct a worker who is observed performing an incorrect or hazardous procedure?

109. State methods used to justify personnel and equipment.

Justifying Personnel and Equipment. You already know that to accomplish the mission you must have the necessary equipment and manpower. In today's Air Force, aircraft systems are being modified every day. Some systems may be removed, improved, or replaced with a complete new system. This may affect your manning and required maintenance equipment. Overtime required to support the mission may indicate undermanning or lack of training. There are many areas that you must look very closely at as you justify personnel. Look at the unit's mission for a starting point. Ask yourself if you are accomplishing tasks normally assigned to other sections? Has the wing been assigned additional flying hours? Has transit aircraft traffic increased? The final question: Are these going to be temporary or permanent conditions? Also check the unit detail listing (UDL) to see how many personnel are authorized. The UDL may authorize more people than are presently assigned. It should be brought to the attention of the commander that the mission cannot be supported properly.

Before personnel and equipment can be justified, it is important to have all the facts. The commander normally keeps close watch over the unit's manning and equipment authorization. It is possible, however, that you may supply one small fact that may be justification for an emergency manpower request. The same is true of equipment. Replacement for faulty equipment or that which is in limited supply and hard to repair may be justified. The commander may want to review the problem with you to insure that all of the facts are known before going to higher commands for help.

Exercises (109):

1. List those conditions that may affect manning and equipment authorization.
2. State two courses of action your commander could take to solve an immediate problem caused by undermanning in your section.
3. Why would the commander want to review your facts?

110. List areas of supervisory responsibility that can be assigned to subordinates and explain how organizational and functional charts are used in assigning personnel to positions.

Assigning Positions, Using Charts. You can clearly see that you, as a supervisor, will have plenty to do. To ease some of your workload, you may begin assigning certain areas of responsibilities to your subordinates. Although you

may assign tasks to others, you maintain the responsibility. As you assign these tasks, you delegate authority to accomplish the task. Duties often assigned to subordinates are on-the-job trainer, equipment manager, section supervisor, safety supervisor, and assistant shop supervisor.

Organizational charts. By developing an organizational chart, you can show a picture of your organization. An organizational chart normally shows one level of supervision above and two levels below the charted position. As supervisor, your chart would show your position as the main position. One above would show your supervisor. Below your position would be your section supervisors and below them, perhaps, would be the technicians/specialists.

Figure 6-12 is an organizational chart that depicts a typical PME laboratory without much detail. Note that the block at the top is smaller than the one underneath with the branch name on it. This is the conventional way of showing that there are a number of higher echelons of command which may initiate and issue instructions to the branch, all of them following the normal chain of command. Units that are subordinate to the branch unit are indicated by appropriate blocks under the larger block, PME Laboratory. Directly connected to the block with the branch name on it are two staff units—Administration and Training. The staff units consist of people who assist the branch chief and provide information and advice to the administrator of the whole branch. Information must flow along the lines shown; that is, only the lines leading to the branch administrator. He or she then makes decisions and issues instructions which flow downward along the lines shown to the units that do the actual work. Note that the information and instructions from the branch chief frequently are the result of communications from the higher echelons to the branch chief. The branch chief may or may not deem it advisable to consult with members of the staff. On significant matters, however, they are usually given information copies of communications from higher echelons.

It is important to note that no one in the Administration or Training units has any authority whatsoever to issue orders to either the electrical-electronics or physical-dimensional areas. However, responsibility for certain phases of the activities of lower units and the authority to issue orders may be delegated by the branch chief. As a matter of fact, this is done quite frequently. It is a sound management practice, although the branch chief is still held responsible to higher authorities for the operation of the branch and its units.

Note also that no one in either of the two lab areas has authority to issue orders to workers in the other area. However, this does not mean that there can be no consultation between workers in the various lower units, with the view to more efficient scheduling of work in each area.

Functional charts. A functional chart will be much like the organizational chart, except the duties and responsibilities of each position will be listed on the chart. It may also list job descriptions and AF publications required to accomplish the assigned tasks. The functional chart serves as a quick reference of the responsibilities required of a specific position.

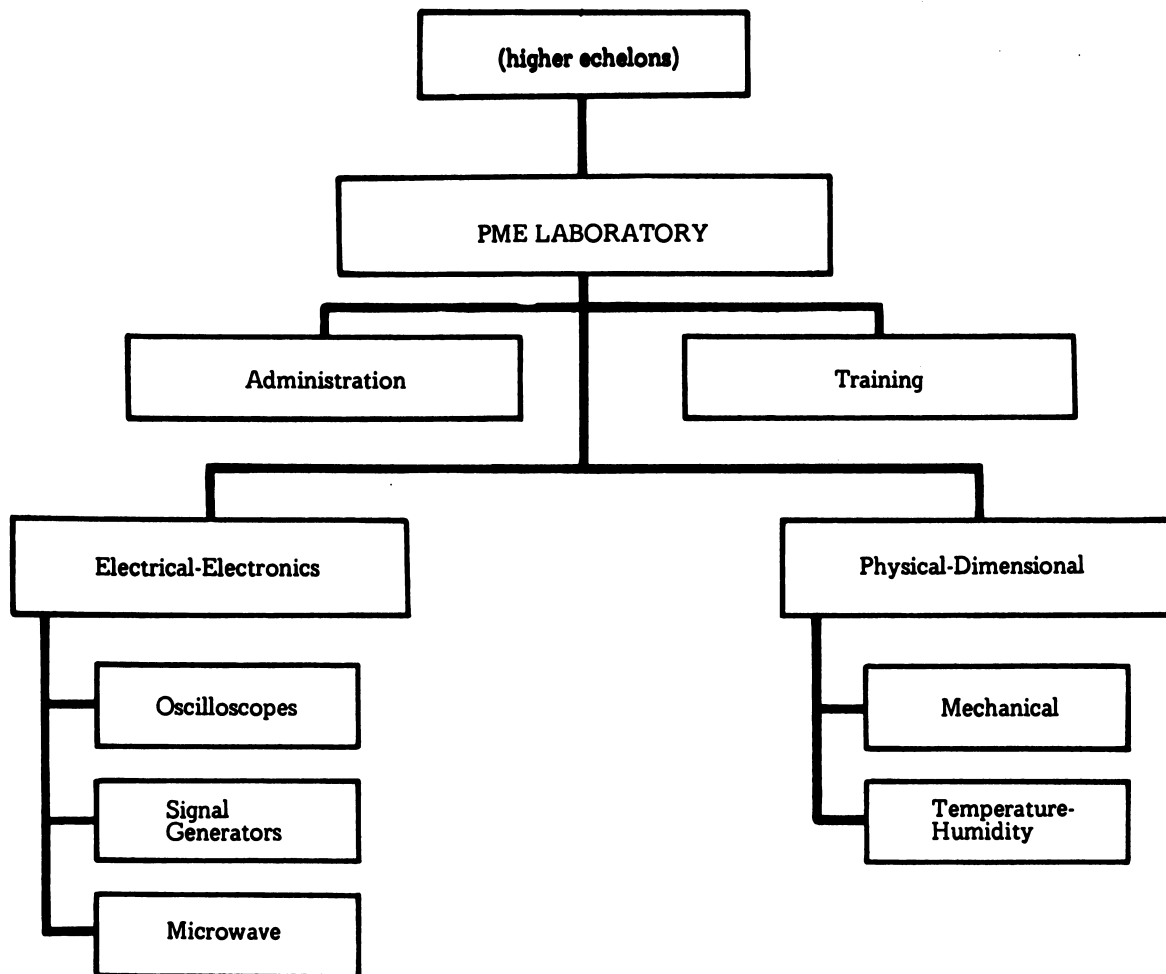

Figure 6-12. Line-staff chart of a typical base PME laboratory.

Exercises (110):

1. List areas of responsibility in which the supervisor may delegate authority to subordinates.
2. What levels of supervision are normally shown on organizational charts?
3. Indicate the information that is listed on the functional chart.

111. State the methods to resolve technical problems encountered by subordinates.

Resolving Technical Problems. You, as a supervisor, will be called upon many times to solve technical problems. "Ask the boss" is the standard answer when anyone encounters a problem. When you are that "boss," you must

come up with the answer. The answers you give will go a long way in establishing your reputation as a supervisor. You must come up with a good answer. Perhaps your past experience will be of use to you in the form of so-called tricks of the trade. Perhaps you will have to research TOs or manuals to come up with the answer. Maybe just telling the worker with the problem where to go to find the answer will suffice. It may be that you will have to ask for outside help if the problem is beyond your knowledge or ability to solve. Never leave a problem unsolved if it is possible for you to solve it. If you refer one of your people to someone else for a solution to a problem, check back with the individual to see if the problem was solved. By doing this, your people will get the feeling that their problems are your problems (which they are), and this situation will increase the worker's confidence in you as a supervisor.

Exercises (111):

1. Who would one of your airmen consult when assistance is needed to solve a problem?

2. What should you do next if one of your people gives you a problem that you cannot answer?
3. When you refer one of your people to someone outside your organization for assistance on a problem, why should you check with the individual to see whether or not the problem was solved?

112. State how workers can recommend and/or initiate policy changes on the use of personnel or equipment and how these recommendations affect the organization.

Because supervisors are not required to perform manual tasks, they rely on the workers to recognize imperfections within the organization on the use of personnel and equipment. These recommendations can save both the Air Force and your unit money and time. It is then up to the supervisor perhaps you to analyze the suggestion carefully and implement the changes necessary to correct the imperfections.

Exercises (112):

1. Who does supervision rely on to recommend policy changes on the use of personnel and equipment? Explain.
2. What can be saved by implementing suggested changes in your organization?

113. State the methods and procedures used to counsel personnel and resolve individual problems.

Resolving Individual Problems. Much has been written about how to get along better with other people. Considerable emphasis has been placed in base-level management training programs on the why and how of working with people in a team spirit to reach a common goal. Let us review some of the ways to resolve individual problems, such as employee relations, and examine procedures for handling problems.

Employee relations. Instead of a long discussion on employee relations, we will list the normal foundations necessary for good employee relations and then outline effective procedures for handling their problems. The following items will aid you with many employee relations problems. They are not all-inclusive, but will give you a start in the right direction. As you observe other supervisors at work and gain experience, you can add to the list.

- a. Let each worker know how he or she is getting along.
 - (1) Tell workers what you expect of them.
 - (2) Point out ways workers can improve their work.
 - (3) Praise in public; criticize in private.

- b. Give credit where credit is due.
 - (1) Look for extra or "beyond the call of duty" type of performance.
 - (2) Tell it while it is "hot."
- c. Tell people in advance about changes that will affect them.
 - (1) Tell them why, if you know.
 - (2) Sell them on the idea of accepting the change.
- d. Make the best use of each person's ability.
 - (1) Look for that extra ability that may not be in use.
 - (2) Never stand in a person's way.

Handling a problem. One of your responsibilities with which you may have trouble at times is handling a problem. You may be confronted with difficult situations which appear to have no solution. There are, fortunately, tried and true ways to help solve most problems. Use the following procedure in a difficult situation:

- a. Get the facts.
 - (1) Review the record.
 - (2) Find out what rules and regulations apply.
 - (3) Talk with the individual concerned.
 - (4) Get opinions and feelings.
 - (5) Be sure you have the complete story.
- b. Weigh and decide.
 - (1) Fit all the facts together.
 - (2) Consider their bearing on each other.
 - (3) Answer this question: What possible courses of action are there?
 - (4) Check practices and policies of your organization at your level.
 - (5) Consider objectively the effect on the individual, group, and work.
 - (6) Don't jump to conclusions.
- c. Take action.
 - (1) Will you handle this yourself?
 - (2) Will you require help?
 - (3) Should you refer this problem to your supervisor?
 - (4) Make your decision and time your actions to fit the decisions.
 - (5) Don't pass the buck.
- d. Check results.
 - (1) How soon will you follow up?
 - (2) How often will you need to check?
 - (3) Observe changes in output, relationships, and attitudes.
 - (4) Has your action increased or decreased the work output of the individual or group?

Exercises (113):

1. What are some of the points to remember when telling workers how they are progressing?

2. When problem solving, what procedures should you apply?

114. Identify the two parts of the graduate evaluation system and the proper forms and standards used by the supervisor for particular aspects of reporting.

Graduate Evaluation Program. The Air Force has established a program to evaluate students of formal courses listed in AFM 50-5 and Career Development Courses prepared by ATC. The program is administered with AFR 50-38, *Field Evaluation of Formal School Graduates*, as a guide. The program is designed to improve personnel management and formal training programs.

The evaluation is divided into two parts: (1) field evaluation visits and (2) direct correspondence questionnaires. Field evaluation visits are performed by representatives of the training activity. These representatives visit the using agencies within 6 months after the graduates are assigned. The second method of evaluation is one in which you, as a supervisor, enter into the picture. Direct correspondence questionnaires are sent to recent graduates and their supervisors. You must fill out questionnaires you receive for school graduates assigned to your unit. For this using activity evaluation, you observe the performance of school graduates in the normal work situation. The graduates perform applicable tasks listed in the STS. You record daily observations in terms of performance and supervision required.

Since these evaluations are needed to pinpoint the ability of graduates to perform the tasks they were trained to do, you must be as accurate in your evaluation as possible. The forms you receive are designed so that you can compare the graduate's performance of tasks with the performance level shown in the STS. In most cases the performance level for the course and the 3-level AFSC are the same. Sometimes,

however, the course is not capable of teaching an item to the desired level. In these cases you should compare the graduate with the course level code. Be sure that you properly indicate STS items that are not performed or not required. When you have not had a chance to have the graduate perform an STS task, it should be indicated as not performed on the questionnaire. On the other hand, if that particular STS task is not required in your unit, the questionnaire should indicate "not required." For example, one of the items on the current STS indicates that a graduate is trained to the 2b level in performing circuit analysis/maintenance of thermal converter meters. If your unit is not responsible for performing maintenance of thermal converter meters, you could indicate "not required" for this STS task.

Whenever you have a graduate who does not meet all of the training codes listed in the STS, you should prepare AF Form 1284, Training Quality Report. This form is submitted to ATC and to the Technical Training Center that sent out the questionnaire. Remember, your accuracy in answering the questionnaire and submitting AF Form 1284 aid in improving the technical training courses.

Exercises (114):

1. What are the two parts of the evaluation system?
2. What should you use as a standard when filling out a graduate evaluation questionnaire?
3. What form is used to report graduates whose training is not up to standard?

Soldering Techniques and Handtools

SOLDER IS one of the oldest, simplest, and most useful of all the metals in use as a fusible alloy. Soldering, because of its very simplicity and ease of application, has come to be regarded as something that can be taken for granted. This is not the case. Engineers and technicians have found that many failures attributed to electrical components were actually the fault of poorly soldered interconnections. Many investigations and studies have been performed on the "soldered connection." From the results of these studies, improvements and changes in the soldering technique have taken place.

7-1. Soldering Techniques

The agency performing the most effective tests, improvements, and changes in the soldering technique is the National Aeronautics and Space Administration (NASA). Their methods and requirements will be used as a basis for this CDC.

Package density, weight savings, and increased reliability are goals in which both NASA and the Air Force have a vital interest. The reduction in size and weight has been brought about by miniaturization. The vacuum tube gave way to the transistor; the hand-wired chassis to the printed circuit board; and finally, entire circuits to one integrated package. The process of reducing electronic packages to the smallest practical unit is called microminiaturization and the final result is a microminiature device.

Many electrical connections have been eliminated by the microminiature device, which must still be connected to an external circuit. One of the best methods of connecting electrical devices is soldering. This makes soldering even more important. One bad solder joint can disable an entire microminiature device where previously a single component or part of a circuit was all that was disabled. Industry, NASA, and the Air Force are becoming more concerned with the importance of the soldered connection. As technicians, we must be equally concerned and knowledgeable in the construction and inspection of the soldered connection. To enable you to more easily construct these solder connections, you must first learn how to prepare a soldering iron tip. You must also be able to strip and tin leads satisfactorily.

115. State what determines soldering iron size and cite methods and procedures used in applying soldering techniques to general type electronic circuits.

Selection of Soldering Iron. The sole purpose of the soldering iron is to heat the joint to a temperature high enough to melt the solder. Select a soldering iron with a thermal capacity high enough so that the heat transfer is fast and effective. An iron with excessive heat capacity will burn

or melt wire insulation; an iron with too little heat capacity will make a cold joint in which the solder does not alloy with the work. Soldering irons are available in wattage ranges from 20 to 500 watts. Irons with wattage ratings of 60, 100, and 200 watts are recommended for general use in aircraft electrical wiring. Pencil irons with a rating of 20 to 60 watts are recommended for soldering small parts. The soldering iron recommended for printed circuit soldering is a lightweight 55-watt iron with a 600° F. Curie point tip control. This iron has a three-wire cord to eliminate leakage currents which could damage the printed circuits.

A soldering iron should also be suited to the production rate. Do not select a small pencil iron where a high steady heat flow is required.

Choice of Soldering Tip. Select the tip best suited for the size and shape of the work being soldered. Soldering iron tips are available in sizes from 1/32 inch to 2 inches in diameter. For general use, a tip of 1/4-inch to 3/8-inch diameter is recommended. For printed circuit soldering, use a long shank tip of 1/32-, 1/16-, 1/8-, 3/32-, or 3/16-inch diameter. Screwdriver, chisel, and pyramid shapes are recommended.

General Solder. Ordinary soft solder is a fusible alloy consisting essentially of tin and lead. When tin and lead are alloyed together, the percentage of tin to lead is expressed as a ratio with tin as the first number.

Example: 60/40 means the tin is 60 percent and the lead is 40 percent.

There are many classes of solder available with many uses and they can be grouped as follows: Flux core type, solid wire, and bar solder. The composition of commercial solder covers the entire range of tin-lead ratios.

With the exception of the eutectic alloy (63% tin/37% lead), all solders in the tin-lead series are ratios that do not melt sharply at any one temperature. The different ratios will pass through an intermediate range of plasticity before going into the liquid range. This intermediate range of plasticity will also take place in the process of cooling from liquid to the solid state.

A working knowledge of the plastic range of solders is very helpful in selecting the type of solder needed for a specific job. For example: In plumbing, a wiping solder consisting of 50-percent tin or less would be acceptable, due to the long time in the intermediate range of plasticity. In electronics, many components are heat sensitive and cannot withstand high temperatures for any length of time, so higher tin alloys which have shorter ranges of plasticity are used.

A tin-lead ratio of 60/40 can best meet the needs when soldering electrical components. A low melting point coupled with a short time in the plastic range reduces the time and temperature on the connection. The 60/40 solder is primarily used in conventional circuits and terminals where

the melting point and flexibility of this solder can be tolerated. The flexibility of 60/40 solder is not as desirable when working on printed circuit boards as when working on conventional circuits. The delicate nature of metal foil wiring and the increased heat sensitivity of miniaturized parts require a solder of a low melting point.

The eutectic composition (63% tin/37% lead), with its negligible plastic range and sharp and distinct melting point, make this 63/37 tin-lead ratio the preferred solder on printed circuit boards. If 63/37 solder cannot be obtained, a tin-lead ratio of 60/40 is sufficiently close to the eutectic composition to be generally acceptable.

General Flux (Product). Common metals when exposed to the atmosphere acquire a thin nonmetallic film known as oxide. The longer the exposure, the thicker this film will become. This oxide film will form an effective insulating barrier. As long as this nonmetallic barrier is present, the metals themselves cannot make actual metal-to-metal contact. As a result, soldering action cannot properly take place.

The function of the soldering flux is to remove this nonmetallic oxide film from the surface of metals and keep it removed during the soldering process. The flux does this by having a melting point lower than the solder being used. As the flux melts, it will first exert a slight chemical reducing action which loosens the trapped oxides on the metal surface. The loosened oxides, wetted by the flux, are coagulated and suspended in the flux body. The solder then melts, floating the lighter flux and impurities suspended in it to the outer surface and edges of the molten solder. Most of the flux is burned away during the soldering process leaving only a small amount of residue upon cooling.

It should be mentioned at this time, that the flux is designed to cope only with metal oxides; it will not remove paint, shellac, sulphides, gross forms of dirt, or other inert matter from the surface of metals.

Soldering fluxes may be conveniently divided into three general groups:

- (1) The chloride of acid type.
- (2) The organic type.
- (3) The rosin or resin type.

General Soldering (Process). Soldering is the process of joining two or more metals together by the application of heat and a low melting alloy. This alloy then flows between and around the metals to be joined. Upon cooling, it solidifies and bonds the metals together.

In its molten state, solder secures attachment by virtue of a metal solvent or intermetallic solution action. The solvent or solution action may be illustrated as follows: Ordinary table salt has to be heated to 1488° F. before it melts. However, when a little water is added, it melts easily without any heat. The action of molten solder on a metal-like copper may, therefore, be compared to the action of water on salt. This solvent or intermetallic solution action chemically dissolves part of the metal surfaces to be joined. The solvent action occurs at temperatures well below the melting point of the metals being soldered.

This solvent property of molten solder at low temperatures is a fundamental property of soft solder. This soft solder property differentiates its behavior from that of brazing

alloys, whose action involves the formation of a fusion alloy with the metal that is being joined, and welding alloys, whose action involves actual fusion of the metals being joined.

A soldered joint is chemical in character rather than purely physical, because the attachment is formed in part by chemical action rather than by mere physical adhesion. The properties of a solder joint are, therefore, different from those of the original solder.

The complete metallic continuity of a soldered connection insures a permanent and constant electrically conductive medium.

Soldering Iron Tip Preparation. Use the following general information and steps in constructing a soldering iron tip. Properly maintaining the soldering iron tip is one of the most important requirements for good soldering. Only flat, fine, single-cut, shear-toothed type files are used for cleaning the dressing cold copper unplated tips. Use a wet, fine texture natural or synthetic sponge for cleaning heated soldering iron tips. Just prior to soldering a connection, the iron must be "thermal shocked" for temperature stability and for cleanliness by wiping the iron on a wet sponge or other suitable material.

Usually, the tip shape that will give the best heat transfer for terminals and printed circuit boards is a wedge shape filed to a 45° angle. Dress the tip daily or as often as necessary, depending on how much work is being done. Always maintain a clean, uniform tip surface that is free of pits so that the iron will tin easily.

Tip preparation:

- a. Plated tips do not require filing or dressing while cold.
- b. Unplated copper tips will have to be filed to shape and dressed while cold.

(1) Remove the tip from the soldering iron. (CAUTION: Be sure the iron is unplugged and cold before touching the tip.)

(2) Clean the entire length of the tip with a clean wire brush.

(3) Clean the hole in the iron where the tip fits with a small piece of braided shield. On some irons, the mating surface between iron and tip will not be a hole. Use a wire brush to clean this surface.

(4) Using the proper file, file the tip to a 45° angle and slightly blunt the end. Draw filing will smooth the final surface.

(5) Replace the tip into or onto the iron and tighten the connection.

(6) Plug the iron into the soldering iron control box and wait for it to heat. As soon as the tip reaches the temperature to melt solder, tin the iron by applying solder to both sides of the heated tip until the entire tip is covered.

Care of the Soldering Iron. A hot tip is never filed because it will oxidize quickly and cause tinning to be difficult. A pool of solder should be left on the iron tip at all times, when not being used. Never leave an iron on for extended periods of time when not being used.

Exercises (115):

1. What determines the size of the soldering iron to be used?
2. What is the function of soldering flux?
3. What type soldering tip gives the best heat transfer for terminals and printed circuit boards?
4. How are nonplated copper soldering iron tips cleaned and dressed?
5. When should hot soldering iron tips be cleaned with a wet sponge?
6. Give the three general groups of fluxes.

116. State what procedures and techniques should be used when soldering components on printed circuit boards.

Soldering Printed Circuit Boards. The successful soldering of printed circuits is based on the same fundamental principles that underlie any other kind of soldering. These principles are:

- a. There must be metallurgical affinity between the metals that are soldered.
- b. These metals must be free of, and remain free from, all nonmetallic surface contamination.
- c. There must be complete and adequate metallic contact between the solder and the metal that is soldered.
- d. There must be a temperature that is adequate for efficient alloy or metal solvent action.

These basic factors appear to be simple, but their successful application is involved and complicated. A strict adherence to technique and procedure will be required.

Terms. Some new terms and definitions that are applicable to all soldering but especially important to printed circuit soldering are:

Wetting: Adhesion of a liquid to a solid surface.

Wetting action: The ability of one metal or alloy, when molten, to flow over or coat another metal alloy.

Wetting agent: A surface active agent that produces wetting by decreasing the cohesion within the liquid. The wetting agent is usually the flux in the solder.

Mobility: A measure of the capacity of the flux to wet the surface of the molten solder in order to facilitate rapid solder flow.

Surface tension: The property, due to molecular forces, that causes liquid to pull away or ball up when applied to a surface. This condition is most prevalent on a very smooth surface of a surface covered with an oily film.

Dihedral angle of wetting: Directly related to solder flow and the condition of the base metal interface at the time of solder contact. It is a measurement of wetting action. Some examples are:

a. When solder melts and then rolls up into round balls, there is minimum wetting action due to surface tension and/or failure by the flux. This ball of solder is measured by the degree of the angle between the base metal and the solder.

b. The solder melts and flows with marginal wetting.

c. When solder melts and continues to flow, on a properly prepared surface, solder fillets tapering to the base metal with a contact angle approaching 0° are not uncommon.

Dihedral angles over 30° indicate marginal wetting. Angles 5° to 30° could be considered acceptable for certain applications. Wetting angles below 5° should be required for high reliability applications. Low dihedral angles of wetting will indicate maximum compatibility between the solder and the base material.

A chemically clean surface is needed to control the angle of wetting so preparation of tin-lead plated boards require cleanliness. Gold-plated boards require preparation of the base metal itself and the removal of the plating.

Dewetting: Condition in a soldered area in which the liquid solder has not adhered intimately, characterized by an abrupt boundary between solder and conductor, or solder and terminal/termination area.

Cold solder connection: Unsatisfactory connection resulting from dewetting and exhibiting an abrupt rise of the solder from the surface being soldered, caused by insufficient application of heat.

Fractured joint: A solder joint in which the solder has fractured or broken between the joint elements and usually caused by movement of the parts to be soldered during the soldering or cooling process.

Board Inspection and Preparation. These operations are simple in nature but are sometimes overlooked.

Board inspection. The printed circuit board being assembled or repaired should be inspected both before and after the actual preparation. Inspect your board for possible rejection as follows:

- Pits or pinholes in circuitry
- Scratches
- Damaged epoxy finish
- Circuit separation
- Scalloped edges
- Circuit blisters
- Board delamination
- Dirt, grease, etc.

Board preparation. Here are the steps you should use to prepare a board.

a. Tin-lead plated boards, the easiest to prepare: scrub with an acid brush dipped in alcohol and wipe dry with a Kimwipe. Check the hole and pad to be sure they are free of foreign matter.

b. Copper clad boards: unplated boards should be cleaned with a white typewriter eraser as shown in figure 7-1. Clean

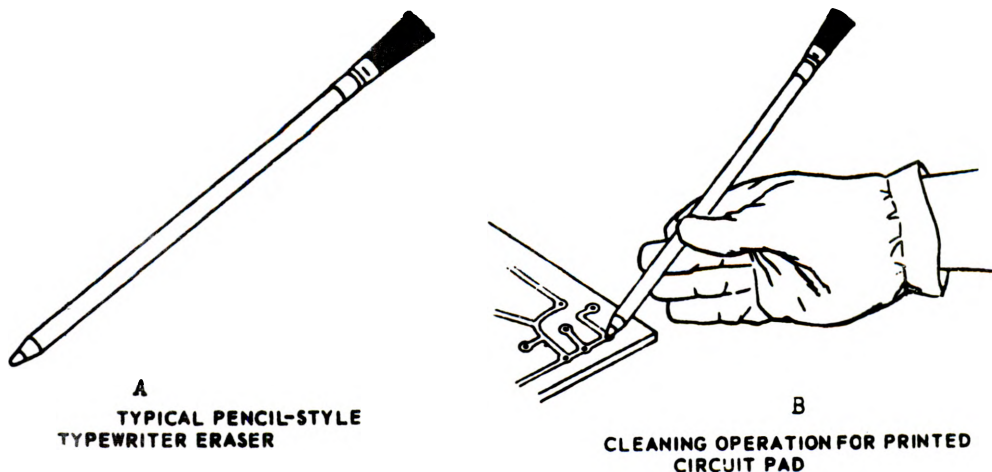

Figure 7-1. Circuit board cleaning.

the pad with the eraser until a bright uniform appearance covers the whole pad. Scrub with alcohol and brush, and wipe dry with a kimwipe. Take care not to get off the pad with the eraser. This will break the finish on the board and weaken it.

c. Gold-plated boards are the most difficult to prepare since the gold plating must be removed in all areas to be soldered. Do this with the typewriter erasure as shown in figure 7-1. The same appearance as the unplated copper clad board is necessary. Again, follow this procedure by using the acid brush with alcohol and wipe dry with a Kimwipe.

Component Forming and Mounting. Now you are ready for the forming and mounting procedures, which are discussed here.

Component forming. Clean all component leads prior to forming them to remove oxidation. Use the component lead cleaning tool. Grasp the component in one hand, and wipe the lead with the lead cleaning tool. A smooth, bright and shiny surface should result.

Mount the printed circuit board in a board holding jig. At least two surfaces of the printed circuit board must be in full contact with the gripping surfaces of the holder. Position the holder so that the conductor runs and pads are on the bottom. Only the holes and board will be visible to the operator from the top.

Form the component leads by using the lead bending jig, sometimes called a lead bender. Refer to figure 7-2. The lead

bend must not be any closer than 1/16 inch to the component body (see fig. 7-3). If the width between the holes causes the leads to be formed closer than this, you have too large a component.

Component mounting. The manufacturer's specifications determine which component to use in the field. If these are not available, a good general rule is to replace the component with one that is exactly the same as the one removed. After the leads have been formed, the component must be made rigid to the board before it is soldered. This is done by clinching leads down flat to the board in the direction of the run. The component is inserted into the board (from the blank side) with the most significant color band to the left until the component body is flush with the board. Refer to point 3, figure 7-4,A.

Rotate the printed circuit board holder 180°. Hold the component flush with the board. Place a spudger at the point where the lead comes through the board, figure 7-4,A, and ride the lead over in the direction of the conductor run until the lead is bent at a 45° angle. Refer to figure 7-4,B. The spudger is used to prevent the pulling which is present when pliers are used.

Using a flush-cutting tool (toenail clippers or flush-cut angle pliers), cut the leads to the proper length, points 1 and 2 of figure 7-4,B. The minimum length is the pad radius and the maximum length is the pad diameter.

A properly formed component is pictured in figure 7-3. The radius of the bend will be no less than twice the lead diameter.

After the component is formed, it will center between the two holes on the board; and the leads will go down through the holes without touching the sides of the holes until the component is flush with the board, as shown in figure 7-5.

Components that have a welded bead on their lead should be formed differently than ordinary resistors. Make the start of the lead bend no closer than 1/16 inch from the bead. If it is formed any closer than this, there is a good chance the lead will break off.

Forming Solder Joint. After the component lead is properly formed, cut, and clinched to the board, clean the connection once again with the acid brush and alcohol; then wipe it dry with a Kimwipe. Inspect the joint under the

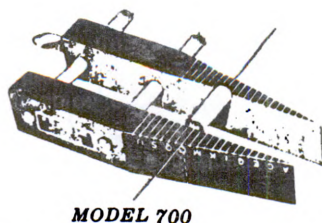

A hand tool for bending leads on resistors, diodes, capacitors, etc., to accurately register with their holes in printed circuit panels. Quickly adjustable to the body length of the smallest diode.

Figure 7-2. Lead bending jig.

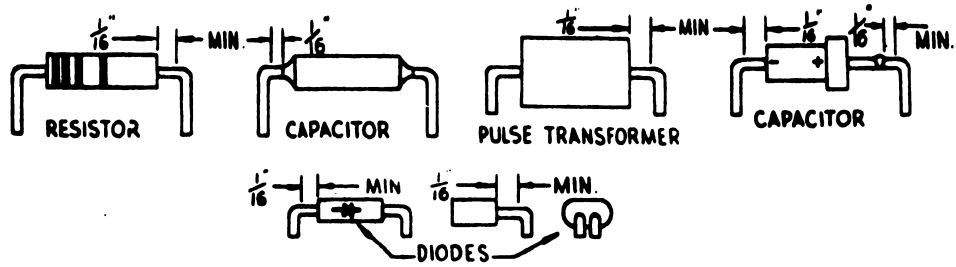

Figure 7-3. Component lead bends.

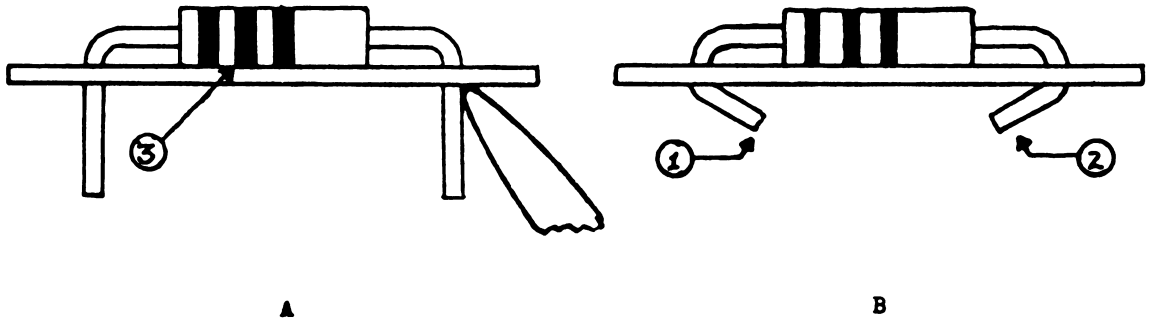

Figure 7-4. Component mounting.

magnifying lamp to be sure there is no foreign matter under the lead or clinging to it. Do all soldering on the printed circuit board with the board in its holder. (NOTE: LARGE TIP (1/8") is used for large pads. A 63/37 solder is used on printed circuit boards.)

Clean and thermal shock the soldering iron tip by wiping it lightly on a wet sponge. Iron temperature is determined by trial and error. There is no less damage to the plastic board when soldering at a high temperature than when soldering at a low one. The board is not sensitive to solder temperature; rather it is sensitive to thermal absorption. The board will absorb less heat in the 1 to 2 seconds required to solder at 550° F. than it would in the 10 to 15 seconds that are required to solder at 450° F. The temperature for most joints is one which is hot enough to heat the joint being soldered and melt solder rapidly (1 to 2 seconds) without frog-eyeing (blistering) the board or causing the joint to be grainy.

Bring the soldering iron in at a 45° vertical angle against the side of the lead, flat and centered on the pad. Refer to figure 7-6.

Form a heat bridge at point B, figure 7-6. Apply solder to the junction of the pad, lead, and tip of the iron. Move solder down the lead in the direction indicated in figure 7-6 to the wire end. Tin the cut end; then move around the outside of the pad, back to the soldering iron. Remove the iron and the solder, being sure to lift the iron UP rather than dragging it straight back.

After the joint is cool, clean it thoroughly with a kimwipe dipped in alcohol; then polish with a dry Kimwipe. This will remove rosin and other matter from the joint. Flux (rosin) serves no purpose once the solder joint is completed. It will collect moisture and dirt if not removed.

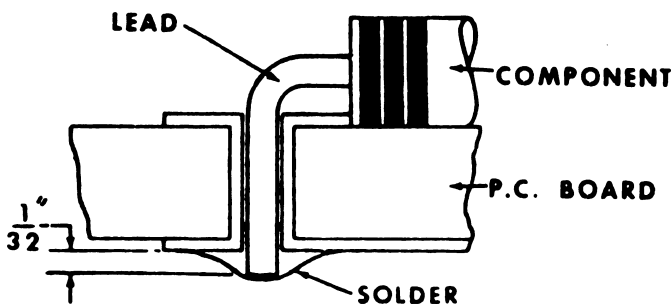

Figure 7-5. Component placement.

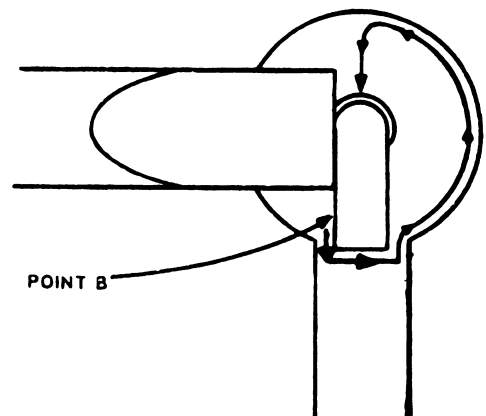

Figure 7-6. Forming solder joint.

Exercises (116):

1. List the eight things you should inspect when making repairs to a printed circuit board.
2. Of the three types of circuit boards, which is the most difficult to prepare for soldering? Why?
3. When bending component leads, what is the minimum distance the bend should be made from the component body?
4. How is a component made rigid to the circuit board before it is soldered?
5. What type of solder should be used on printed circuit boards when repairs are being made?

117. State the soldering procedures and techniques that should be used when working on microminiature circuits.

Soldering Microminiature Circuits. Microelectronic devices are relatively new to the technician. Like the transistor, when first introduced, it caused much confusion until the technology of installation, testing, and replacement was established.

Once properly installed, microelectronic devices will withstand great amounts of abuse and vibration, but the best engineered device in the world is no better than the solder joints that hold it in the circuit.

In manufacturing techniques, many different methods are used to secure these devices to printed circuit boards. Those methods used by industry include parallel gap welding,

resistive soldering, thermal agitation, electron beam bonding, and reflow bonding.

Only the reflow bonding method of lead attachment is practical for field maintenance application. Special tools are held to a minimum and the necessary soldering skill techniques are easily acquired.

Lead preparation and forming. If the leads are gold-plated, remove this plating from the end of the lead to the first stress relief bend.

One of the most common microminiature devices, is the flat pack. The leads on a flat pack must have stress relief bends. This will enable the operator to use a heat sink. Also, when the board flexes, the leads will not break. The leads on a flat pack are delicate and must be treated carefully.

The only approved method for forming flat pack leads is with a lead forming jig. Place the flat pack in the bottom section of a forming jig; then place the top section on top of it, being careful to line up the number in the upper right. Apply a gradual pressure downwards until the leads are formed.

Carefully remove the top section of the forming jig and remove the flat pack with tweezers. Trim the flat pack leads, using the electrician's scissors or a flush-cutting tool, to the length necessary to fit the board.

Flux method of installation. Some form of heat sink must be used when soldering microminiature electronic devices. An example of an acceptable heat sink is a modified hair clip.

Before mounting, determine the location of the key. The key may be identified in several ways. Some common methods are: a dot in one corner, one corner painted, or one end leg that is different than the rest. Refer to figures 7-7 and 7-8,A, 7-8,B, and 7-8,C. Place the flat pack in the heat sink and position it on the printed circuit board.

Using a piece of .030 solder dipped in flux, dab each lead with the flux. The soldering iron temperature should be high enough to complete a soldered connection in 1 to 5 seconds, (500° to 550° F.). Solder the individual leads to their respective runs using the flux method. Using a 1/32-inch soldering iron tip, place the iron at the junction of the lead end and the run, as shown in figure 7-9.

Form a heat bridge using .015 63/37 solder; then move solder along the lead towards the flat pack for 1/8 inch; then remove solder and iron. Repeat this procedure for all leads. Clean the joint with alcohol and carefully wipe it dry. Remove the heat sink and inspect the connection.

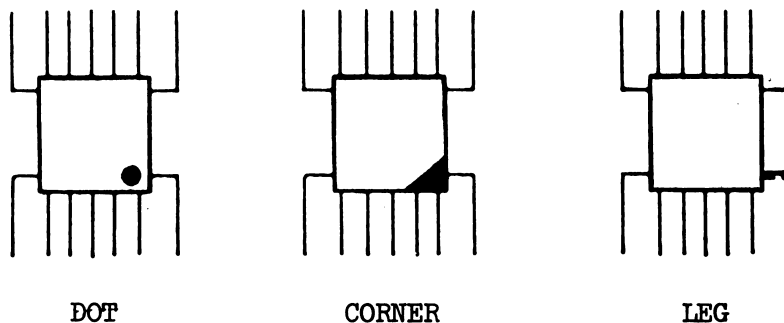
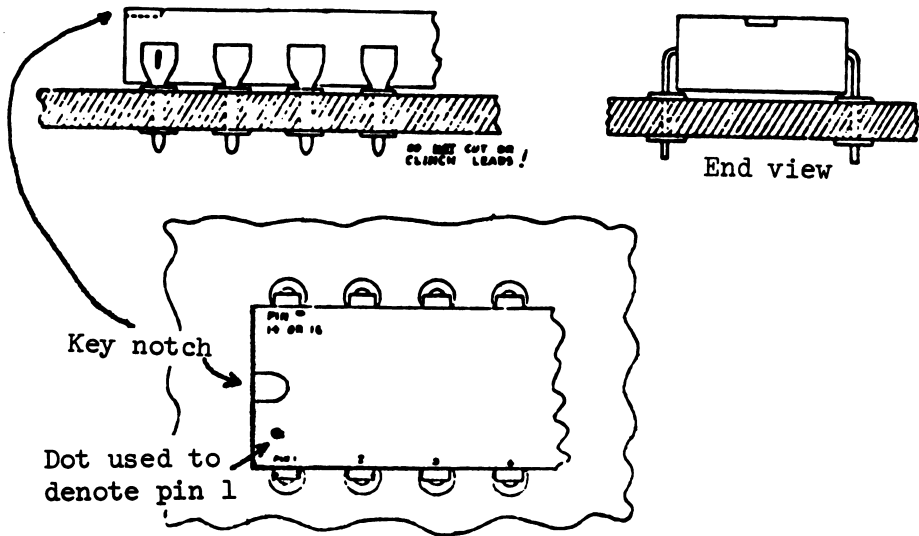
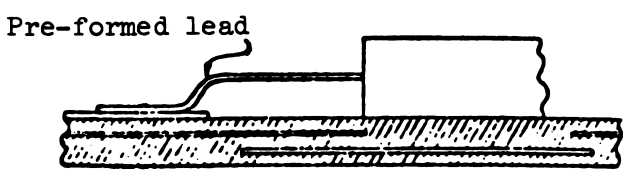

Figure 7-7. Flat pack "key" location.



A. 14 or 16 lead Dual-in-line IC (DIP)



B. Flatpack IC (side view of those shown in Fig. 7-7).

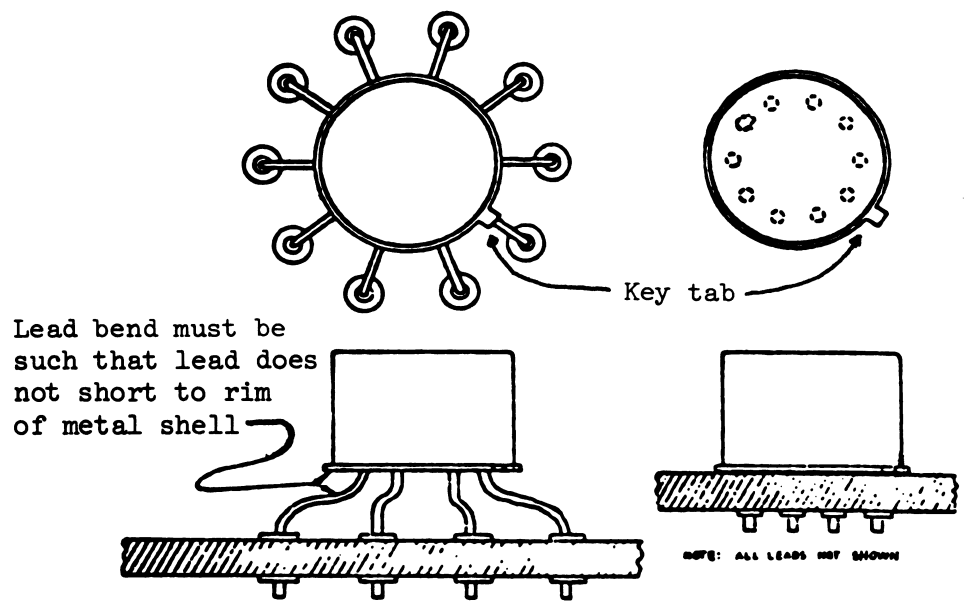

Expanded lead style

Straight lead style

C. TO-5 can

Figure 7-8. Microminiature devices.

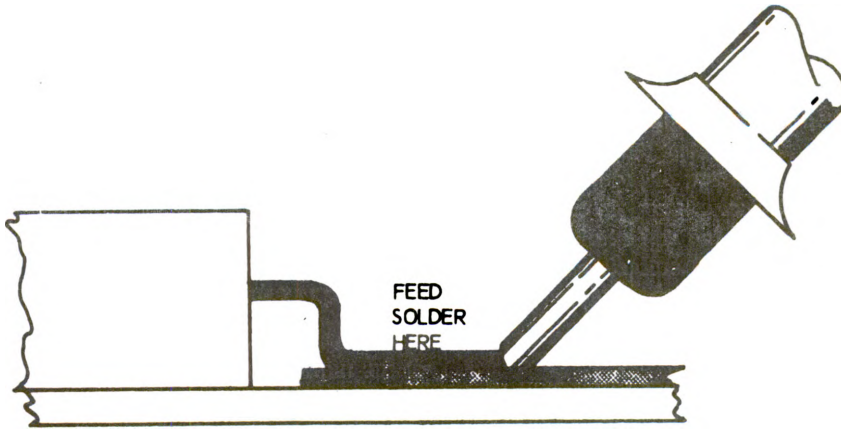
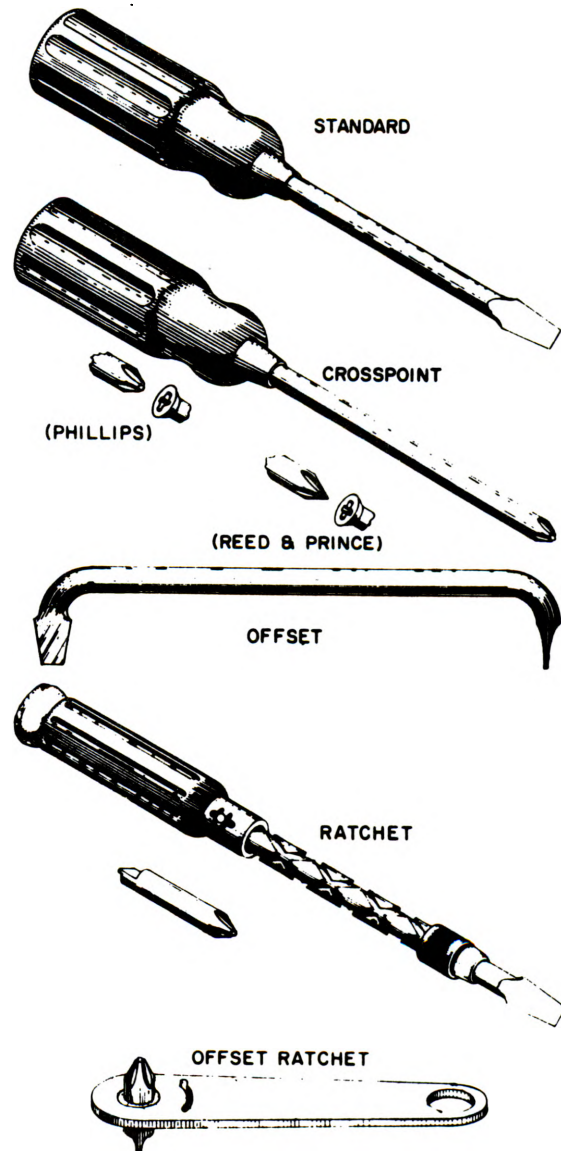

Figure 7-9. Soldering technique.

Exercises (117):

1. What is the reason for forming flat pack leads?
2. What size soldering iron tip is used to solder flat packs?
3. At what temperature should soldering be accomplished?
4. What is the recommended method for forming flat pack leads?



7-2. Handtool Use

The information in this section will help you improve your own work habits and help you recognize good workmanship in your subordinates. It is very important that each lab technician select the proper tools for the job, use the tools correctly, and care for them properly.

The handtools described in this section are representative of those used in maintaining your equipment. These tools, for the most part, are familiar to you; yet they are the most misused of all tools. You may think that you know all about tools and how to use them, but check yourself everyday when you are performing maintenance on a system. Do you always use the right tool? If you use the right tool, do you use it correctly? Bear in mind that your work is also judged by the manner in which you handle and care for your tools.

118. Identify types of screwdrivers and state their purpose, proper use, and care.

Screwdrivers. Screwdrivers, illustrated in figure 7-10, are designed for one specific purpose—to tighten or loosen screws. They are not designed to be used as crowbars, bottle

Figure 7-10. Screwdrivers.

openers, punches, or voltage testing devices. They are quite often used for these purposes, and for these reasons there are many broken tips and bent shanks. Screwdrivers are usually classed as standard, crosspoint, or offset. There may be variations of these types to fit particular jobs.

Standard. The standard screwdriver is suitable for most ordinary jobs. You determine the size of a standard screwdriver by measuring from the tip of the blade to the handle. The blade must have sharp corners and must fit the slot in the screw snugly, as shown in figure 7-11, to prevent slipping and damaging the slot.

Crosspoint. The crosspoint screwdriver may be one of two types—Phillips or Reed and Prince. The crosspoint screwdriver differs from the standard type in that the blade is designed to fit the two slots which cross at right angles to each other in the head of the screw. Note the differences in the blades of the screwdrivers illustrated in figure 7-10. Because of the differences in blades, these screwdrivers are not used interchangeably—such misuse will damage the screwhead. The crosspoint types are also available in different sizes, and it is important that you choose the proper size for each job.

Offset. The offset screwdriver makes it possible to work in tight corners where straight types will not enter. The two blades of this screwdriver are set at right angles to each other so that the screw may be turned a quarter turn at a time by using opposite ends alternately. The offset screwdriver may be either a standard or a crosspoint.

Ratchet. The ratchet screwdriver is designed so that once the blade is inserted into the screw slot, the screw can be turned completely in or out by using the ratchet action without removing and reinserting the driver blade for each turn of the screw. The ratchet screwdriver may have a standard or a crosspoint blade, or it may be designed so that the blades are interchangeable. On offset ratchet screwdrivers you may find that one blade is standard and the other is crosspoint. The ratchet direction of this type of screwdriver is controlled by a small lever on the handle of the screwdriver.

Maintenance and storage. To keep the blade of your screwdrivers in good condition, you may need to use a grinding wheel to reshape the blade. Grind the blade with sides parallel to keep it from lifting from the screw slot when in use. Grind the tip of the blade only enough to remove nicks and square it up. Crosspoint screwdrivers require a special holding fixture to grind, but in an emergency you may reshape them by filing. Use care to maintain the original angles and bevels. Ratchet screwdrivers require a light oiling

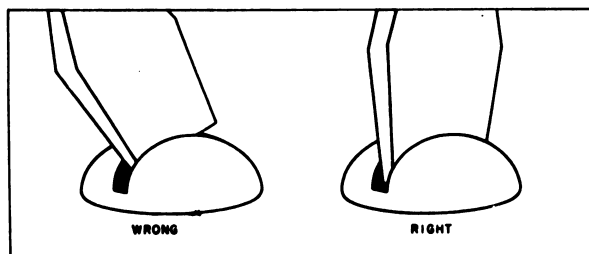

Figure 7-11. Screwdriver size.

occasionally to insure free movement of the ratchet. When screwdrivers are to be stored, spread a rust preventive compound over metal parts and put them in a dry place. When you remove them from storage for use, wash the metal parts with drycleaning solvent to remove the rust preventive compound.

Exercises (118):

1. What are some common misuses of the screwdriver?
2. How should you determine the size of screwdriver blade to use for a particular job?
3. How does the crosspoint screwdriver differ from the standard type screwdriver?
4. What is the purpose of an offset screwdriver?
5. What is the advantage of the ratchet type screwdriver over the offset screwdriver when working in tight corners?
6. What care is necessary to maintain a ratchet screwdriver that is not required of a standard screwdriver?

119. Identify the different types of pliers, state their purpose and use, and specify their proper care.

Pliers. As you well know the pliers, shown in figure 7-12, are very useful tools. They are used to hold small objects and to bend or to cut thin wire or metal strips. Pliers vary in size—from small pliers used by electronic specialists to large ones used by linemen.

Adjustable combination. Adjustable combination pliers are often called slip joint pliers. They are used for cutting and twisting wire, pulling or spreading cotter pins, and general utility operations. They are very rugged, and the jaws can be opened to more than one size of opening because of the adjustable pivot or slip joint. They are used for holding round stock or light metal, but should never be used in the place of a wrench.

Long nosed. Long-nosed (needle-nosed) pliers are used in electronic maintenance work where space is limited and parts are small. They are suitable for bending or forming fine wire or thin sheet metal. These pliers may or may not have side cutters behind the gripping surface of the jaws. The cutter portion, if present, is usually fine for light cutting, such as soft iron, brass, or copper. It will cut if it is not abused.

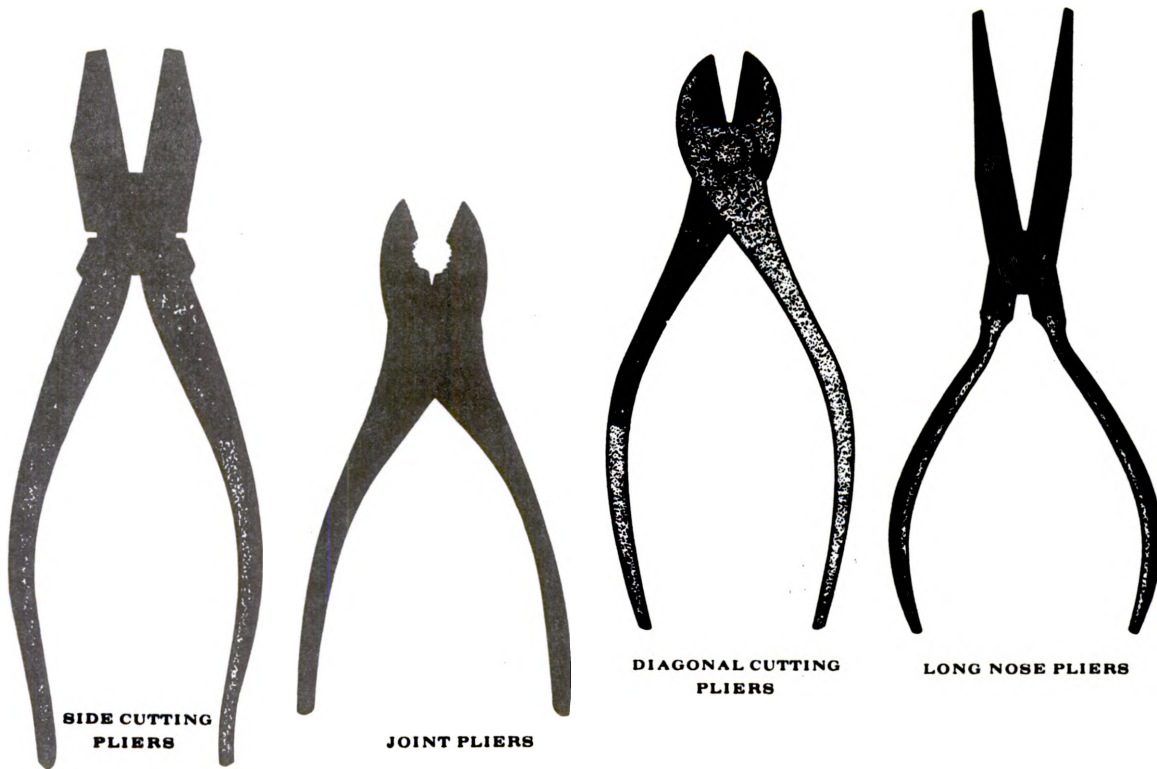

Figure 7-12. Pliers.

Diagonal cutting. Diagonal-cutting pliers consist of two cutting edges set at an angle of 15° to 20° with respect to the length of the tool. They are used for cutting wire or component leads. The common misuse of diagonal cutters is forcing them to cut heavier wire or metal than that for which they were intended.

Side cutting. Side-cutting pliers are heavy duty pliers that combine the gripping jaws of the combination pliers and the cutting surface of the diagonal cutters. The jaws of the side-cutting pliers are broader than those of the combination pliers. Side cutters are used for cutting heavy wire. The jaws are excellent for pulling and bending heavy gauge electrical conductors. The cutting edges will cut heavy gauge soft wire.

Maintenance and storage. Many of the pliers you use may be filed or reground when the cutting edges or serrations become dull. File or grind them only enough to remove nicks or burrs. Remove approximately the same amount from each jaw. Clean the serrated jaws with a small wire brush. Whenever they become covered with grease and oil, you should wash them in dry cleaning solvent and then wipe them dry. After the pliers are completely dry, lubricate the pivot pin with one or two drops of lubricating oil. Whenever pliers are stored, apply a thin film of rust preventive compound and store them in a dry place. When they are removed from storage, wash them with drycleaning solvent to remove the rust preventive compound.

Exercises (119):

1. For what are pliers primarily used?
2. What is the purpose of the slip joint on the adjustable combination pliers?
3. State one advantage of needle-nosed pliers.
4. What is the most common misuse of diagonal-cutting pliers?
5. The design of side-cutting pliers serves what combined purpose?
6. Specify the storage requirements for various types of pliers.

120. State the basic purpose of wrenches, explain the advantages of the different types, and specify the measures necessary to maintain and properly store these tools.

Wrenches. A wrench is a tool used to apply a turning force to boltheads, nuts, and capscrews, or for gripping round material such as pipes, studs, or round rods. The wrenches shown in figure 7-13 are a few of the ones you will be using.

Adjustable. An adjustable wrench has one fixed jaw and one movable jaw. The jaw is movable by the use of a screw adjustment. The adjustment wrench may be opened or closed to fit the flats of the nut or to fit the bolthead to be turned. As a rule, an adjustable wrench is suitable for heavy-duty work in places easy to reach. It has the disadvantage of tending to round off the corners of hex nuts unless the jaws are closely adjusted to fit the nut. When using the adjustable wrench, place the strain on the fixed jaw, as shown in figure 7-13, and not on the movable jaw. By putting strain on the movable jaw, you may spread the jaws if too great a force is applied.

Open end. An open-end wrench (see fig. 7-13) is nonadjustable. It may be open on either or both ends of the wrench. This type wrench is usually light, strong, and convenient for working in a limited space. The jaws are set at an angle (usually 15° or 90°), and it is easy to increase the swing of the wrench by turning it over. Open-end wrenches normally range in sizes from 3/16 inch to 1 1/4 inches and are usually graduated in 1/16-inch increments. Wrenches for special uses may be obtained in 1/32- or 1/64-inch graduations. On wrenches with both ends open, one end is

the next size larger than the other end. The wrenches are proportional in length to the size of the openings. This proportions the leverage of the wrench to the nut and helps prevent damage to the wrench and the work.

Box. Box wrenches are also nonadjustable wrenches similar in size to open-end wrenches. Box wrenches have 6-, 8-, or 16-point surfaces inside the head. The number of points determines the strength of the wrench. The most common box wrench is the 12 point, which gives a maximum swing of 30° to the wrench. Unlike the open-end wrench, a box-end wrench completely incloses or "boxes" the nut. The sides of the wrench are thin so that it may be used on nuts close to another object. In general, you will find that you can use a box wrench in close places where another kind of wrench would never fit.

Hex. The hex, or Allen, wrench is L-shaped and is designed to fit setscrews or hexagonal socket heads of screws and bolts. The wrenches usually come in kits containing sizes from 1/32 inch to 3/8 inch. You may also have socket sets with an "Apex" adapter that holds straight hexagonal wrenches. An Allen wrench and a socket with an Allen wrench are shown in figure 7-13.

Socket. A socket wrench is used where it is necessary to operate in close or difficult to reach places. The socket is used with a ratchet handle that requires only a very short swing. Each socket wrench is supplied with a set of sockets. The sockets are designed to fit standard size nuts and are readily fitted onto or removed from the handle. Sockets normally come with 8- or 12-point surfaces inside the head; however, they may have a 6-point surface for heavy-duty work. The nut can be completely tightened without removing

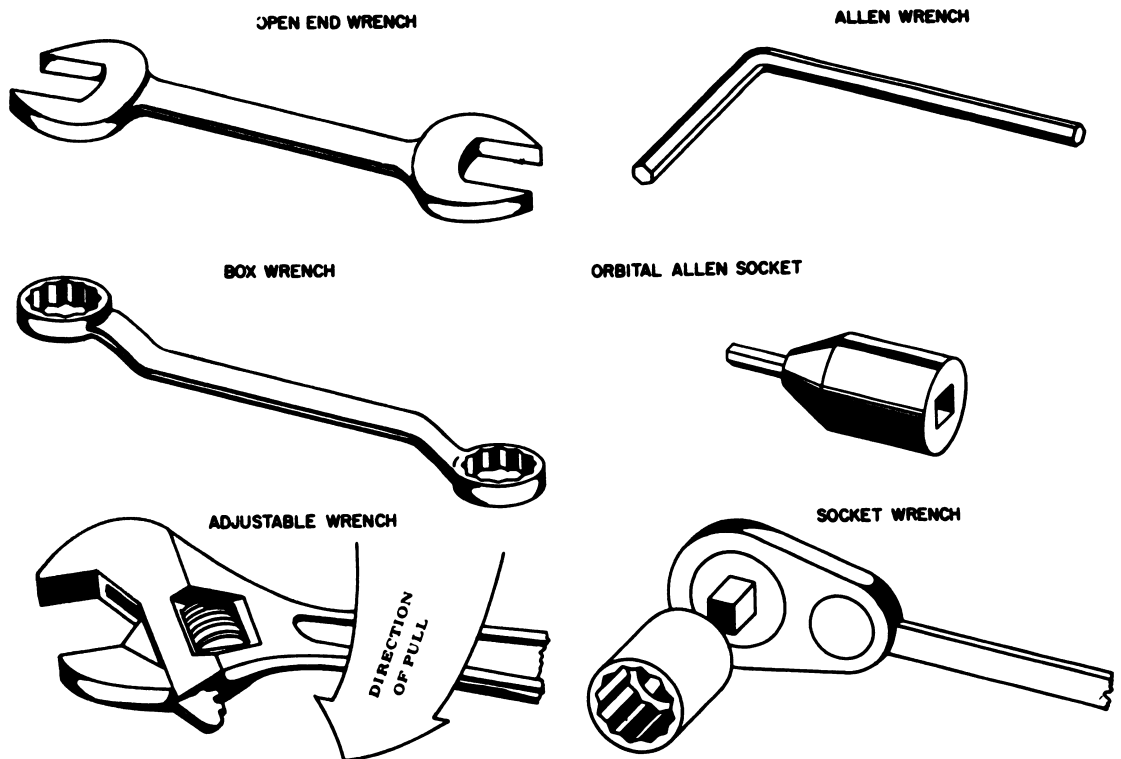

Figure 7-13. Wrenches.

the wrench from the nut. Socket wrenches are used with a variety of drives, such as the ones illustrated in figure 7-14: (A) speed handle, (B) extension, (C) ratchet handle, (D) T-handle, and (E) hinged handle or breaker bar.

Maintenance and storage. Wash grease or dirt from wrenches with drycleaning solvent and wipe dry. Remove rust spots with crocus cloth of fine aluminum oxide abrasive and coat the wrenches with preservative lubricant. Lubricate the sides and worms of adjustable wrenches with one or two drops of oil. Before storing, coat them with a rust preventive compound and store them in a dry place.

Exercises (120):

1. State the basic purpose of wrenches.
2. State one disadvantage of the adjustable type wrench.
3. What is the advantage of the box-end wrench over the open-end wrench?
4. For what purpose was the L-shaped Allen wrench designed?
5. After cleaning grease or dirt from wrenches and wiping them dry, what should be done before coating a wrench with a preservative lubricant?

121. List the types of extractors, state the purpose of these tools, and explain the procedures necessary to properly use and store them.

Extractors. Extractors, shown in figure 7-15, are used to remove broken bolts, screws, studs, taps, and heli-coils.

Screw extractor. The screw extractor, generally called an "easy-out," is tapered and has sharp ridges (similar to left-hand threads) which grip the sides of the hole drilled in the broken part so that the part may be backed out of the hole. To extract a broken screw, bolt, or stud, drill a hole into the body of the broken part; the hole should be slightly smaller than the diameter of the body. Then insert the extractor into this hole and turn it counterclockwise.

Tap extractor. The tap extractor has movable fingers that are placed in the flutes of the broken tap, as shown in figure 7-15, after which the collar is brought up against the surface of the work. A tap wrench is then used on the extractor to back out the broken tap. The tap extractor will not stand much turning force without breaking the movable fingers. Care must be taken to prevent breaking the extractor.

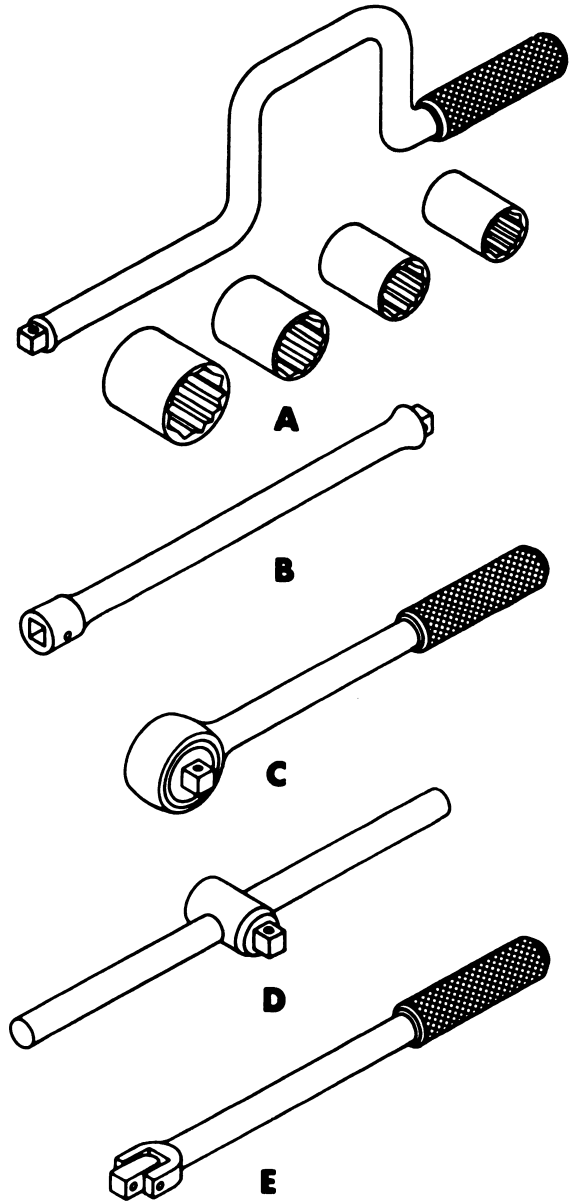

Figure 7-14. Socket wrenches.

Heli-coil extractor. Heli-coil extractors are designed especially to remove heli-coil inserts. To use the extractor, insert it into the hole and gently screw the heli-coil counterclockwise out of the hole. Heli-coil inserts are used in aluminum case sections. The extractor is made of a harder metal; therefore, take care not to damage hole threads during removal.

Store extractors so that the edges will not be chipped or dulled and so that any movable fingers will not be bent. Use a rust preventive compound on extractors that are to be stored for a long period of time.

Exercises (121):

1. What is the purpose of extractors?

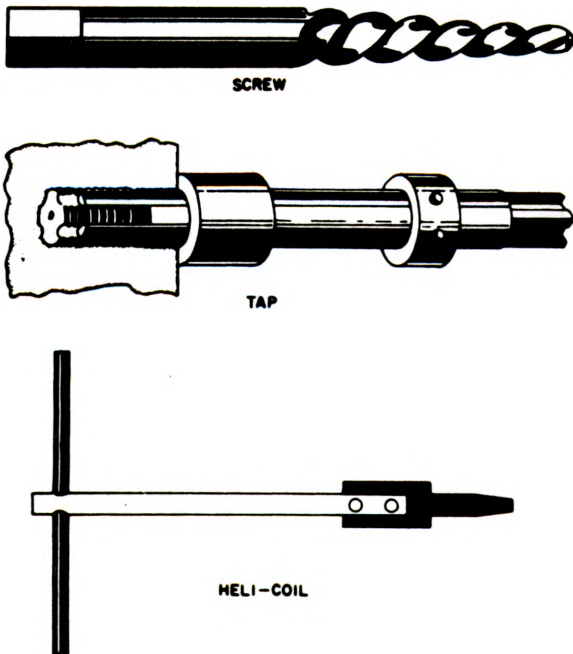

Figure 7-15. Extractors.

2. List three types of extractors.
3. What is the screw extractor commonly called?
4. What are the procedures for removing a broken tap?
5. What are the procedures for removing a heli-coil insert?

6. What special care is necessary when storing a heli-coil extractor?

122. State the basic functions of mechanical wire strippers and explain the correct use and proper care of these tools.

Wire Stripper. The wire stripper, shown in figure 7-16, is a tool designed to cut, hold, and strip the insulation from an electrical wire in one operation. It has two sets of jaws, one of which holds the wire while the other cuts and pulls the insulation off. The jaw that cuts through the insulation has four sets of cutting teeth for various sizes of wire. Each set of cutting teeth is marked with two numbers showing the size of insulation through which the teeth can cut without harming the wire.

Use. To operate the wire stripper, first determine the size of wire to be stripped. Place the wire between the proper set of cutting teeth with the length to be stripped extending beyond the cutting jaw. Squeeze the handles until the teeth come together; continue to squeeze the handles until the cutting teeth cut through the insulation. Then move the stripper outward, pulling the cut insulation toward the end of the wire. Release the handles; if the cut insulation does not fall off, pull it off by hand. Do not strip a wire with a set of cutting teeth that are too small. This causes the teeth to cut into the metal of the wire and dulls the teeth, weakens the wire, and eventually throws the cutting jaw out of alignment.

Maintenance and storage. Protect the cutting teeth when you are using the wire stripper or when it is in storage. Oil the pivot points at regular intervals, and keep the tool clean and free of surplus oil and grease. A light coating of thin oil protects the tool from rust while it is not in use.

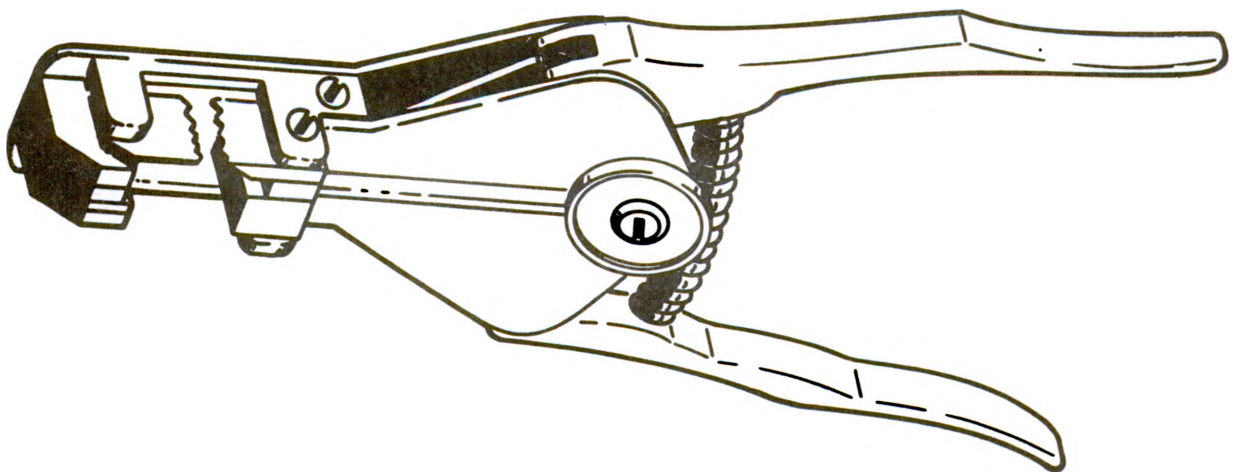

Figure 7-16. Wire stripper.

Exercises (122):

1. What three basic functions can be performed in one operation with the wire stripper when working with electrical wire?
2. What precaution must be observed when using mechanical wire strippers?
3. What protective measures should be observed and applied when storing mechanical wire strippers?

Bibliography

Department of the Air Force Publications

- AFR 0-1, Guide to Indexes, Catalogs, and Lists of Departmental Publications.*
- AFR 0-2, Numerical Index of Standard and Recurring Air Force Publications.*
- AFM 1-1, United States Air Force Basic Doctrine.*
- AFR 5-4, Publications Numbering Systems.*
- AFR 39-1, Airman Classification Regulation.*
- AFR 50-5, USAF Formal Schools Catalog.*
- AFM 50-23, On-the-Job Training.*
- AFP 50-34, Military Training Standard Promotion Fitness Exam Study Pamphlet.*
- AFP 50-56, USAF Aerobics Physical Fitness Program (Male).*
- AFR 66-1, Maintenance Management Policy.*
- AFM 66-267, Maintenance Data Collection System, Users Manual.*
- AFR 74-2, Air Force Metrology and Calibration Program (METCAL).*
- AFR 127-101, Ground Accident Prevention Handbook.*
- TO 0-2-1, Alphabetical Listing of Equipment and Technical Order Number Groups.*
- TO 0-4-2, Cross-Reference Table of Time Compliance Technical Orders to Applicable Data Code Numbers.*
- TO 0-4-6-1, Numerical Cross-Reference Equipment Numbers to Air Force Technical Order Numbers.*
- TO 00-5-1, AF Technical Order System.*
- TO 00-20-14, Air Force Metrology and Calibration Program.*
- TO 33K-1-100, PME Interval, Labor Estimate, Calibration and Repair Technical Order Reference Guide and Work Unit Code Manual.*

NOTE: None of the items listed in the bibliography above are available through ECI. If you cannot borrow them from local sources, such as your base library or local library, you may request one item at a time on a loan basis from the AU Library, Maxwell AFB AL 36112, ATTN: ECI Bibliographic Assistant. However, the AU Library generally lends only *books* and a limited number of *AFMs*. *TOs*, classified publications, and other types of publications are not available. Refer to current indexes for latest revisions of and changes to the official publications listed in the bibliography.

ANSWERS FOR EXERCISES

CHAPTER 1

Reference:

- 001-043. Answers are in the back of the 5-level OJT module.
- 044 - 1. Tasks and knowledges are derived from the duties and responsibilities section of the specialty description in AFM 39-1.
- 044 - 2. The extent of training on each tank for upgrading and the extent to which formal courses and CDCs provide training on each subject and task knowledge.
- 045 - 1. Normally a 3 skill level, but could be done by a 5 level.
- 045 - 2. 5 and 7 skill level.
- 045 - 3. 5 skill level.
- 045 - 4. 7 skill level.
- 046 - 1. 100 points.
- 046 - 2. 131.25 points.
- 046 - 3. Time in service.
- 046 - 4. 33 points.
- 046 - 5. Military subjects and management practices.

CHAPTER 2

- 047 - 1. When enemies know in advance they are going to be attacked, they have time to plan counteractions or avoid that attack. History has shown us the age-old practice of counterintelligence; for example, the practices discovered during the Viet Nam war.
- 047 - 2. To keep the tactical and strategic advantage on our side by protecting information and activities regarding our plans.
- 048 - 1. Identify those portions of an operation that require protection, develop OPSEC procedures and techniques, systematically assess OPSEC status at all operational levels, and document deficiencies and institute corrective actions.
- 048 - 2. Operations, communications, and procedures.
- 048 - 3. Any type of information that could reflect a change in procedure or operations, whether the information seems important or unimportant.
- 049 - 1. Yes. This is a routine community relations effort, usually screened and cleared by the Office of Information.
- 049 - 2. No. This conversation deals with a probable limitation on a strategic weapon system component.
- 049 - 3. No. This conversation deals with the distances to the location of strategic weapons systems components from a known point.
- 049 - 4. Yes. This is a routine story for acknowledging excellence.
- 049 - 5. No. This also appears to be a probable compromise of classified material, since the "(S)" indicates Secret classification.
- 049 - 6. No. This information reveals a probable change in some part of the missile system, thus pointing toward other changes.
- 050 - 1. (1) d.
(2) c.
(3) a.
(4) e.
(5) b.

CHAPTER 3

- 051 - 1. Learning and understanding how to do the job accurately and safely before doing the job.

- 051 - 2. For personal safety and protection of equipment.
- 051 - 3. Self-discipline and outside discipline.
- 051 - 4. Law enforcement outside discipline.
- 052 - 1. Conversation and horseplay.
- 052 - 2. Horseplay.
- 052 - 3. Conversation with fellow workers could cause you to take your mind off your work and could cause a safety hazard.
- 052 - 4. Daydreaming and boredom.
- 052 - 5. Daydreaming.
- 052 - 6. Willpower—force yourself to pay attention.
- 053 - 1. From handling materials.
- 053 - 2. Back injury.
- 053 - 3. By lifting with your legs you avoid bending your back and placing a severe strain on your spinal column.
- 054 - 1. As alcohol numbs and slows down the operation of your nervous system, your normal work routine slows down, creating a climate conducive to accidents.
- 054 - 2. By not being able to see your work clearly, you could create a safety hazard.
- 054 - 3. To prevent damage to your ears due to high noise levels.
- 055 - 1. a. Not following safety precautions.
b. Not using safety devices.
c. Operating equipment without proper authority.
d. Operating unsafe equipment.
e. Working without sufficient experience.
f. Working at unsafe speeds.
g. Careless housekeeping.
h. Indulging in horseplay.
i. Assuming unsafe body position while working.
j. Failing to warn individuals of possible dangers.
- 055 - 2. You must first recognize the existence of hazards, then take corrective action to eliminate the hazards.
- 056 - 1. Heat, light, space, and proper equipment.
- 056 - 2. About the only thing you can do is to slow down your work pace, use extra precautions, and think before doing that otherwise normal task.
- 056 - 3. Good housekeeping will remove many potential safety hazards from the environment.
- 057 - 1. Many unnecessary operations are used in performing tasks which create many mistakes that result in many unsafe actions.
- 057 - 2. The safety instructions may indicate special rules, protective clothing, and/or machine guards required for safe operation of the type equipment or machinery with which you must work.
- 058 - 1. If any machine is not in good condition, you may have a loss of job efficiency and/or a safety hazard.
- 058 - 2. Meter leads with broken insulation; probe tip broken off; sharp, ragged edges on a piece of equipment; frayed and broken cables; and defective speed control.
- 058 - 3. You should become thoroughly familiar with the various parts of the equipment, and become especially familiar with the safety hazards that may develop due to defective or worn parts.
- 059 - 1. The second person can prevent fatality when an accident occurs by giving immediate first aid. Also, accidents may be prevented because the two personnel can aid each other in observing and applying safety precautions.
- 059 - 2. Pull fuses, open circuit breakers, or disconnect circuits from their power sources.

- 059 - 3. Turn off the power.
- 059 - 4. To prevent completing a circuit path through your body that would occur if you placed one hand on a voltage source and the other hand on a ground point.
- 060 - 1. Electrical shock, cuts, burns, falls, strains, bruises, explosions, and particles in the eye.
- 060 - 2. Goggles will prevent flying particles from injuring your eyes.
- 060 - 3. Place a cleaning rag on a suitable surface and wipe the hot tip across it.
- 061 - 1. Over 50 milliamperes.
- 061 - 2. A safety observer should know enough about first-aid procedures that he or she can help until qualified medical attention arrives.
- 061 - 3. To prevent accidental stumbling into high-voltage circuits.
- 061 - 4. Discharge high-voltage capacitors with a shorting rod.
- 061 - 5. Make certain that equipment under test is properly grounded and that all test equipment is grounded to it.
- 062 - 1. Only qualified and authorized persons.
- 062 - 2. A power unit must be placed at least 50 feet away from fueling operations or where fuel spillages may occur.
- 063 - 1. TO 42B5-1-2.
- 063 - 2. The name of the gas is stenciled parallel to the longitudinal axis on the opposite sides of the cylinder.
- 063 - 3. Threads on regulators or unions must be the same as those on the cylinder valve being used.
- 063 - 4. The threads don't match due to the difference in number of threads per inch or type of thread. Thread mismatch produces leaky connections.
- 063 - 5. Replace the valve protection caps, using extreme care not to damage the outlet threads.
- 063 - 6. To clear the valve of dust, dirt, or moisture which could enter the regulator after it is connected to the cylinder valve.
- 063 - 7. The valve seat may be damaged, which could cause the escape of gas.
- 063 - 8. To prevent sudden discharge of gas into the regulator, which could damage it.
- 063 - 9. Because they are odorless and tasteless, they are hard to detect. They can dilute atmospheric oxygen to unsafe levels and create an asphyxiation danger. In addition, when under high pressure, they present a serious hazard to personnel because of the very large amounts of energy stores in them.
- 063 - 10. Bodily contact results in severe frostbite.
- 063 - 11. AFR 127-101.
- 063 - 12. At least two persons.
- 064 - 1. a. Alpha rays.
b. Beta rays.
c. Gamma rays.
- 064 - 2. Alpha radiation.
- 064 - 3. Beta radiation.
- 064 - 4. Gamma radiation.
- 064 - 5. In units of roentgens per hour (R/HR).
- 064 - 6. They can damage tissues if taken internally.
- 064 - 7. A film badge or dosimeter must be worn to measure the amount of radiation received.
- 064 - 8. a. An accident while handling a nuclear weapon.
b. A crash of an aircraft carrying a nuclear weapon.
c. An aircraft requiring repair that has flown through a contaminated area.
- 064 - 9. A radiation placard is colored yellow and has a symbol colored magenta (reddish purple).
- 065 - 1. a. Radar.
b. Electronic countermeasure devices.
c. High-frequency radio transmitters.
- 065 - 2. A rise in internal body temperature with resulting damage to vital organs.
- 065 - 3. Avoid areas where RF energy is being transmitted.
- 065 - 4. A radiation absorption screen.
- 066 - 1. The source must be kept locked at all times when not in actual use.
- 066 - 2. The source must not be removed from the shield container under any circumstances.
- 066 - 3. At all times when working with or near the exposed source.
- 067 - 1. The container is made of lead encased in steel.
- 067 - 2. A data plate reflects the chemical isotope symbol, activity, calibration date, serial number, intensity, a radiation caution symbol, and the words "Caution—Radioactive Material."
- 068 - 1. The responsibilities are:
a. Obtain authorization to maintain source in PMEL.
b. Observe established radiation protection measures.
c. Adequately document all maintenance actions.
d. Insure personnel are trained.
e. Insure radiation areas and materials are properly marked.

CHAPTER 4

- 069 - 1. The numbers are used to identify specific groups of publications.
- 069 - 2. AFR 5-4, *Publications Numbering Systems*.
- 069 - 3. The base number for training is 50; for supply, 67; and for publications management, 5.
- 069 - 4. AFR 5-4.
- 070 - 1. AFR 0-1, *Guide to Indexes, Catalogs, and Lists of Departmental Publications*.
- 070 - 2. AFR 0-8.
- 070 - 3. (1) c.
(2) d.
(3) a.
(4) b.
- 070 - 4. 0—Indexes; 0-2.
- 070 - 5. Recurring Periodicals; 0-2.
- 070 - 6. Obsolete Publications.
- 071 - 1. AFM 50-5, *USAF Formal Schools Catalog*.
- 071 - 2. AFR 0-2, *Numerical Index of Standard and Recurring Air Force Publications*.
- 071 - 3. AFRP 11-1, *TIG Brief*.
- 072 - 1. The second number group, in this case, -12, identifies the specific item or an equipment type, model, or part number to which the TO refers.
- 072 - 2. The last group of a five-part TO number identifies the section of a sectionalized manual. An illustrated parts breakdown is a section of such a manual and is identified in the last part or number group of the TO number.
- 072 - 3. The TO category is identified in the first part or number group of the TO number.
- 073 - 1. When a part of an existing TO is updated to show new information or when the existing part is obsolete, a change is issued to the basic TO.
- 073 - 2. The obsolete pages are discarded, and the new, changed pages replace them.
- 073 - 3. A new title page is issued with each change, bearing the original publication date and change date. The word "CHANGE" is printed across the face of the new title page.
- 073 - 4. Page A, the List of Effective Pages, is updated to show the latest issue date. It reflects the completeness and current status of the TO.
- 074 - 1. When revised data cannot be adapted to change pages or when the data can be more expediently, economically, or practically issued as a supplement.
- 074 - 2. A supplement bears the same number as the TO which it supplements, followed by a letter suffix.
- 074 - 3. Appendixes are published to include material that is not part of the normal sequence outlined in the table of contents, such as tables, charts, foldouts, or supplementary information.
- 074 - 4. Appendixes issued as a separate publication are issued with a changed title page, bearing a revised publication date and a CHANGE strip.
- 074 - 5. When changed material affects more than 80 percent of the text.
- 074 - 6. A revision to a TO replaces the original publication, all changes, appendixes, and in most cases all supplements to the existing TO.
- 075 - 1. The first number group of an index TO number is "0."

- 075 - 2. The third number group identifies the TO category.
- 075 - 3. Supplements to an index bear the same numerical designator as the basic index, followed by a letter suffix.
- 075 - 4. TO 0-2-1, an alphabetical listing of equipment and TO number groups.
- 075 - 5. LOAP, *List of Applicable Publications*.
- 076 - 1. Detailed information and instructions required for the operation, maintenance, inspection, overhaul, and identification of parts of aircraft, missiles, and other equipment.
- 076 - 2. TO 0-1-01.
- 076 - 3. Air Force Logistics Command (AFLC).
- 076 - 4. The manufacturer of an item of equipment purchased by the Air Force. If the commercial manual has been assigned a TO number, it may be requisitioned through the applicable NI&RT. If no TO number has been assigned, the manual may be obtained through local channels.
- 077 - 1. Immediate action, urgent action, and routine action.
- 077 - 2. TCTOs are used to direct extensive modification and modernization of Air Force equipment.
- 077 - 3. Immediate action TCTOs are issued to correct conditions that could result in fatal or serious injury to personnel or extensive damage or destruction to valuable property. Urgent action TCTOs are issued to correct conditions which may be potentially hazardous to personnel, valuable property, or mission accomplishment.
- 077 - 4. Immediate action TCTOs are identified by a border of red Xs and red identification notes. An urgent action TCTO is identified by red identification notes and a border of alternating circled red Xs and red diagonals.
- 077 - 5. To correct equipment or procedural deficiencies which could constitute a hazard through prolonged usage.
- 077 - 6. Category 1 routine action TCTOs are accomplished by organizational and field maintenance activities. Category 2 routine action TCTOs are accomplished by depot level maintenance activities.
- 077 - 7. When the urgency of conditions does not allow time for printing and distributing instructions in formal TO format.
- 077 - 8. Interim TOs are replaced by formal TOs within 10 days. They are transmitted by radiogram, telegram, teletype, messageform, or any other type of speedy communication.
- 077 - 9. When an equipment modification must be accomplished by a contractor or a specific Air Force activity.
- 078 - 1. To provide information and instructions in various subject areas for supervisory and administrative personnel.
- 078 - 2. Publications in the 00 category are of the methods and procedures type.
- 079 - 1. Used as work simplification devices which aid personnel in carrying out instructions that are contained in other types of technical orders.
- 079 - 2. In a two-column, demand-response checklist, the demands or tasks to be accomplished are listed in sequence in the left-hand column; the responses to the demands are marked in the right-hand column as they are accomplished.
- 080 - 1. To test and verify certain procedures that have been developed for use with the first test or early production models of some weapon systems or their ground support equipment.
- 080 - 2. PTOs are not controlled by an applicable NI&RT.
- 080 - 3. By the word "PRELIMINARY" printed on the title page and by their sequential copy numbers.
- 081 - 1. Mission impact, personnel and aerospace safety, damage to equipment, work simplification, urgency of need for change, and manpower savings.
- 081 - 2. a. Emergency report—the deficiency would result in fatal or serious injury to personnel, extensive damage or destruction of property, or inability to maintain operational posture.
b. Urgent Report—the deficiency could result in personnel injury, damage to equipment or property, reduce operational efficiency, or jeopardize the success of the mission.
c. Routine report—the deficiency may result in a potential hazardous condition through prolonged use, have a negative

effect on operational life or efficiency of equipment. Also, this type report is used for work simplification or manpower savings.

- 081 - 3. They will issue an interim safety TCTO within 48 hours.
- 081 - 4. 30 calendar days.
- 081 - 5. The AFTO 22 is a personal report by a technician of a deficiency to those who can correct the deficiency.
- 081 - 6. Both the supervisor and the quality control or operations standardization officer must sign the form, indicating their approval.
- 081 - 7. TO 00-5-1.

CHAPTER 5

- 082-095. Answers are in the back of the *Maintenance Management* module.
- 096 - 1. A materiel deficiency report would not be submitted on the basis of the hole alone. This damage was apparently caused in shipping and reporting would be done by other means.
- 096 - 2. Any deficiency that affects equipment or personal safety is reported as a Category I deficiency.
- 096 - 3. Category II deficiency report.

CHAPTER 6

- 097 - 1. (1) To establish a base-level capability for the repair and calibration of all types of test equipment and (2) to establish a system to maintain, calibrate, and distribute standards.
- 097 - 2. Since you are most likely assigned to a BP MEL, your job is more directly associated with the base-level capability to repair and calibrate all types of test equipment.
- 097 - 3. AFR 74-2.
- 098 - 1. TO 00-20-14.
- 098 - 2. National Bureau of Standards.
- 098 - 3. The Naval Observatory calibrates Precise Time and Time Interval Standards for the Air Force.
- 098 - 4. 6 months. The minimum interval must be determined by the using activity and/or the PMEL.
- 098 - 5. No. The item need be calibrated only on the ranges or points at which it is used.
- 098 - 6. Contact the user and see if partial calibration will suffice. If not, forward a request for command certification.
- 098 - 7. The goal is to upgrade each laboratory's measurement capability to the optimum.
- 099 - 1. It is affixed to standards and PME certified by AF calibration laboratories.
- 099 - 2. PME having adjustments that affect calibration.
- 099 - 3. When the items of equipment require no calibration or certification.
- 099 - 4. It is a record of PME that is maintained when automated scheduling reports are not available.
- 099 - 5. a. It is used in conjunction with AFTO Form 108 when certifying PME at other than full range.
b. It is used with AFTO Form 108 when it is necessary to show a correction that must be applied to the indicated reading to obtain the actual value.
- 099 - 6. The setting of the calibrating standard.
- 099 - 7. Only those persons authorized to perform calibration and certification.
- 099 - 8. The 33K or 33L series calibration technical order number or the maintenance technical order number or special or local instruction source that was used to perform the calibration.
- 099 - 9. AFM 66-267.
- 099 - 10. When the PME was calibrated to less than the accuracy or functional capabilities specified in the calibration procedure or to bring to the attention of the PME user that calibration data of a correction chart was prepared to supplement the AFTO Form 108.
- 099 - 11. When the equipment is too small to accommodate an AFTO Form 108 or when the certification label must be displayed on the operational side or front of the unit.
- 099 - 12. You add the difference between the standard reading and the test

- instrument reading and enter the sum using the plus of minus sign to indicate high or low test instrument readings.
- 099 - 13. It is used for PME that is to receive a limited calibration or for PME that is to be exempted from periodic calibration.
- 099 - 14. The PME user/owner who submits it to the PME calibration facility.
- 100 - 1. To instill the philosophy that the working area is a laboratory.
- 100 - 2. If the technician is to receive special training at the higher echelon laboratory.
- 100 - 3. The turn-in must be approved by AGMC.
- 100 - 4. You should review all items on the command certification list and see if the PMEL can now calibrate any of these items by using the new piece of equipment.
- 100 - 5. No. A need for the item must still be shown before supply will issue the item.
- 100 - 6. 73.0° F. ± 1°.
- 100 - 7. The Deputy Commander for Maintenance.
- 101 - 1. It means that individuals have to pay for the loss, damage, or destruction of property resulting from their maladministration or negligence in the use, care, custody, or safeguarding of such property from causes other than fair wear and tear.
- 101 - 2. Cash Collection Voucher, the Statement of Charges, and the Report of Survey.
- 101 - 3. The Statement of Charges.
- 101 - 4. When one will not admit pecuniary liability or when the amount involved is \$500 or more.
- 102 - 1. Item description, manufacturer's name, and part number.
- 102 - 2. The table of allowance (TA) for the applicable Air Force activity.
- 102 - 3. a. Date of request and unit designation.
b. Unit supply request number.
c. Name and telephone number of the unit supply custodian.
d. Equipment stock number or part number, and name or description of item.
e. Justification for the request to include the applicable allowance document and a brief statement of circumstances.
f. Quantity required.
g. Certify by the commander or commander's representative to validate the requirement.
- 103 - 1. Job Control.
- 103 - 2. The supervisor must work with many agencies to insure that the work and training schedules are kept and on time.
- 104 - 1. The planning and scheduling of work assignments and setting of priorities.
- 104 - 2. Manpower and equipment.
- 104 - 3. It may be necessary to borrow equipment or work around other personnel.
- 104 - 4. To satisfy mission requirements as soon as possible.
- 105 - 1. No. A 3-level specialist may have special qualifications or experience in a particular area.
- 105 - 2. Job knowledge is learned by working on specific type of equipment assigned, while the skill level is awarded by the Air Force to indicate the knowledge level.
- 105 - 3. Job knowledge and skill level are important in assigning work, but it is equally important to check the priority of the assigned task.
- 106 - 1. Make frequent checks to see if the work is being done correctly.
- 106 - 2. Supervisor.
- 106 - 3. a. To assure that the equipment operates properly and safely.
b. Inspection of the completed work can serve as a training situation.
- 106 - 4. The supervisor should comment on how well the job was completed but also point out the holddown mount bolts. By taking time to explain the proper method to safety-wire these bolts, he or she will probably keep the person from making the same mistake again.
- 106 - 5. Jobs may have to be redone completely if an error is made at the beginning of the task. Making several inspections while the task is being performed, rather than making one final inspection, will save time and increase work output.
- 107 - 1. The supervisor can use them to analyze maintenance activities and determine work patterns of the personnel.
- 107 - 2. The supervisor should analyze the tasks that are requiring too much time.
- 107 - 3. At least three graphs.
- 108 - 1. Performance standards. Standards enable a supervisor to evaluate the quality of the work his or her personnel are accomplishing. If standards are not met, workers are not fulfilling their responsibilities or performing their assigned duties, which could result in mission failure.
- 108 - 2. The supervisor should correct all substandard conditions as soon as possible to avoid substandard conditions from becoming the acceptable standards.
- 109 - 1. Modification of equipment, excessive overtime, TDY commitments, additional duties, additional flying hours, and transiting aircraft traffic.
- 109 - 2. Reassign tasks to other sections; request emergency manning.
- 109 - 3. To insure that all the facts are known before going to higher commands for assistance.
- 110 - 1. The supervisor may assign many areas to subordinates. Among these could be (1) on-the-job trainers, (2) shop training monitor, (3) test equipment monitor, (4) equipment monitor, (5) shift supervisors, (6) safety supervisor, (7) team chiefs, (8) mobility supervisor, (9) dispatchers, and (10) his or her assistant.
- 110 - 2. One level of supervision above and two levels below the charted position.
- 110 - 3. Listed under each assigned position on the functional chart are the responsibilities of the position and the publications that are normally used by that function.
- 111 - 1. The immediate supervisor.
- 111 - 2. Research the problem and rely on past experience.
- 111 - 3. By checking back, you make the worker feel that his or her problems are your problems; and this increases the person's confidence in you as a supervisor.
- 112 - 1. His or her subordinates. To recognize imperfections, because they have firsthand experience.
- 112 - 2. Time, money, and equipment.
- 113 - 1. Let workers know what is expected of them; point out ways to improve; and praise workers in public and criticize them in private.
- 113 - 2. Always get the facts, weigh and decide, take action, and then check the results.
- 114 - 1. Field evaluation visits and direct correspondence questionnaires.
- 114 - 2. The Specialty Training Standard.
- 114 - 3. AF Form 1284, Training Quality Report.

CHAPTER 7

- 115 - 1. Prime importance is to select a soldering iron with a thermal capacity high enough so that the heat transfer is fast and effective.
- 115 - 2. To remove the nonmetallic oxide film from the surface of metal and keep it removed during the soldering process.
- 115 - 3. A wedge-shaped tip that has been filed to a 45° (degree) angle.
- 115 - 4. (1) Remove the tip from the soldering iron.
(2) Clean the entire length of the tip with a wire brush.
(3) Clean the hole in the iron where the tip fits with a small piece of braided shield.
(4) File the tip to a 45° angle and slightly blunt the end.
(5) Install the tip into the iron.
(6) Tin the iron by applying solder to both sides of the heated tip.
- 115 - 5. Just prior to soldering a connection.
- 115 - 6. Chloride of acid, organic, and rosin or resin.
- 116 - 1. Printed circuit boards should be inspected for the following:
(1) Pits or pinholes in circuitry.
(2) Scratches.
(3) Circuit separation.
(4) Circuit blisters.

- (5) Board delamination.
- (6) Dirt, grease, etc.
- (7) Damaged epoxy finish.
- (8) Scalloped edges.
- 116 - 2. Gold-plated boards, since the gold plating must be removed in all areas to be soldered.
- 116 - 3. No closer than 1/16 inch to the component body.
- 116 - 4. By clinching leads down flat to the board in the direction of the run.
- 116 - 5. 63/37 solder.
- 117 - 1. Flat pack leads are formed for stress relief bends. There are two reasons for this. The first is to allow for the use of a heat sink when mounting, and the second is to prevent the leads from breaking if the board flexes.
- 117 - 2. A 1/32-inch soldering iron tip.
- 117 - 3. Somewhere between 500° and 550° F.
- 117 - 4. The only approved method for forming flat pack leads is with a lead forming jig.
- 118 - 1. Screwdrivers are often misused for crowbars, bottle openers, punches, and voltage testing devices.
- 118 - 2. The screwdriver blade must fit the slot in the screw snugly to prevent slipping and damaging the slot.
- 118 - 3. The crosspoint screwdriver blade is designed to fit two slots crossing at right angles in the head of the screw.
- 118 - 4. The offset screwdriver makes it possible to work in tight corners where screws cannot be reached with straight screwdrivers.
- 118 - 5. The ratchet screwdriver is designed so that once the blade is inserted into the screw slot, the screw can be turned completely in or out without removing and reinserting the driver blade due to the ratchet action.
- 118 - 6. Ratchet screwdrivers require a light oiling occasionally to insure free movement of the ratchet.
- 119 - 1. To hold small objects and for bending or cutting thin wire or metal strips.
- 119 - 2. The slip joint on adjustable pliers enables them to be adjusted to different sized openings.
- 119 - 3. Needle-nosed pliers can be used to work in small spaces and on small parts.
- 119 - 4. Forcing the pliers to cut heavier wire or metal than they were designed to cut.
- 119 - 5. Side-cutting pliers were designed to have the heavy duty gripping jaws of the combination pliers and the cutting surface of the diagonal cutting pliers.
- 119 - 6. Whenever pliers are stored, apply a thin film of rust preventive and store them in a dry place.
- 120 - 1. The wrench is designed to apply turning force to boltheads, nuts, or capscrews, and for gripping around materials such as pipes or studs.
- 120 - 2. Tends to round off the corners of hex nuts unless the jaws are closely adjusted to fit the nut snugly.
- 120 - 3. The box-end wrench can be used in closer places than the opened wrench.
- 120 - 4. To fit setscrews or hexagonal socket heads of screws and bolts.
- 120 - 5. Remove rust spots with crocus cloth or fine aluminum oxide abrasive.
- 121 - 1. To remove broken bolts, screws, taps, and heli-coils.
- 121 - 2. Screw, tap, and heli-coil.
- 121 - 3. Easy-out.
- 121 - 4. Place the movable fingers of the tap extractor into the flutes of the broken tap, move the extractor collar up against the work, and back out the broken tap by turning the extractor with a tap wrench.
- 121 - 5. Insert the heli-coil extractor on the heli-coil insert and gently turn it out counterclockwise. Be very careful not to damage the heli-coil hole threads during the removal process.
- 121 - 6. Coat extractors with a rust preventive, and protect the edges against chipping and dulling and the movable fingers against bending.
- 122 - 1. Cutting, holding, and stripping the insulation from electrical wire.
- 122 - 2. Do not strip a wire with a set of cutting teeth that are too small. Using stripper cutting teeth that are too small will cut into the metal of the wire, dull the stripper teeth, and weaken the wire, eventually throwing the cutting jaw out of alignment.
- 122 - 3. Protect the cutting teeth, oil the pivot points at regular intervals, keep the tool clean and free from surplus oil and grease, and apply light oil to prevent rust while not in use.

