



MAX1910 Evaluation Kit

General Description

The MAX1910 evaluation kit (EV kit) is a fully assembled and tested printed-circuit board (PCB) containing a complete circuit driving four parallel white LEDs. The circuit operates from a 2.7V to 5.3V input supply. A MAX1910 comes installed on the board, but the EV kit can also be used to evaluate the MAX1912.

Component List

DESIGNATION	QTY	DESCRIPTION
C1, C2	2	0.47 μ F \pm 10%, 10V X5R ceramic capacitors (0603) Taiyo Yuden LMK107BJ474KA
C3, C4	2	2.2 μ F \pm 10%, 10V X5R ceramic capacitors (0805) Taiyo Yuden LMK212BJ225KG
D1–D4	4	White LEDs (surface-mount, 3mm x 2mm) Kingbright AA3020RWC/A
JU1	1	3-pin header
R1–R4	4	15 Ω \pm 5% resistors (0805)
R5, R7	0	Not installed, resistors (0805)—PCB shorts
R6	0	Not installed, resistor (0805)
R11	1	1 Ω \pm 5% resistor (0805)
R13	1	100k Ω \pm 5% resistor (0805)
U1	1	MAX1910EUB+ (10-pin μ MAX)
—	1	Shunt
—	1	PCB: MAX1910 Evaluation Kit+

Component Suppliers

SUPPLIER	PHONE	WEBSITE
Kamaya	260-489-1533	www.kamaya.com
Kingbright	909-468-0900	www.kingbright.com
Taiyo Yuden	800-348-2496	www.t-yuden.com

Note: Indicate that you are using the MAX1910 or MAX1912 when contacting these component suppliers.

μ MAX is a registered trademark of Maxim Integrated Products, Inc.

Features

- ◆ Current-Regulated Charge Pump
- ◆ 60mA Output Current
- ◆ No Inductor Required
- ◆ 750kHz Operation Minimizes Input Ripple
- ◆ Uses Small Ceramic Capacitors
- ◆ Load Disconnected in Shutdown
- ◆ 1 μ A Shutdown Current
- ◆ Small 10-Pin μ MAX[®] Package
- ◆ Fully Assembled and Tested

Ordering Information

PART	TYPE
MAX1910EVKIT	EV Kit
MAX1910EVKIT+	EV Kit

+Denotes lead-free and RoHS-compliant.

Quick Start

Procedure

The MAX1910 EV kit is fully assembled and tested. Follow the steps below to verify board operation.
Caution: Do not turn on the power supply until all connections are completed:

- 1) Preset the power supply to between 2.7V and 4.2V.
- 2) Verify shunt JU1 is on pins 1-2 (enable).
- 3) Connect the positive (+) lead of the power supply to the IN1 pad.
- 4) Connect the negative (-) lead of the power supply to the GND pad.
- 5) Turn on the power supply.
- 6) Verify that the LEDs are lit.
- 7) Vary the power supply from 2.7V to 4.2V.
- 8) To verify shutdown mode, move shunt JU1 to pins 2-3. The LEDs turn off.
- 9) Move shunt JU1 back to pins 1-2. The LEDs turn back on.

Evaluates: MAX1910/MAX1912

MAX1910 Evaluation Kit

Detailed Description

Jumper Selection

Shutdown Mode

The MAX1910 features a shutdown mode that reduces input current to 0.1µA (typ). Place the shunt across pins 1-2 of JU1 for normal operation. Place the shunt across pins 2-3 of JU1 for shutdown mode (Table 1).

Table 1. Jumper JU1 Functions

SHUNT LOCATION	SHDN PIN	OUTPUT
1-2	Connected to IN	Enabled
2-3	Connected to GND	Shutdown

Regulating the Total Current Through LEDs

In the default configuration, the current through LED D4 is set by the resistor R4. The current through the other LEDs tracks the current in the regulated LED. Refer to the MAX1910/MAX1912 IC data sheet for other LED matching and ballasting configurations.

The EV kit can also be configured to regulate the total current through the LEDs by following these steps:

- 1) Cut the PCB traces that short the pads for R5 and R7.
- 2) Short the pads of R6.
- 3) R5 remains open.
- 4) Install a resistor in R7. R7 sets the sum of all LED currents, and its value is found from:

$$R7 = \frac{0.2}{I_L}$$

Connecting an External Load

To use an external load in place of the four LEDs (such as an LED module), first follow the steps listed in the *Regulating the Total Current Through LEDs* section. Next, remove the four LEDs (D1–D4), or the four ballast resistors (R1–R4). An external load can now be connected from OUT1+ to OUT1-. The current through the external load is regulated to the current set by R7.

Evaluating the MAX1912

To evaluate the MAX1912, carefully remove U1 from the PCB and replace it with the MAX1912. Free samples of the MAX1912 can be obtained from Maxim.

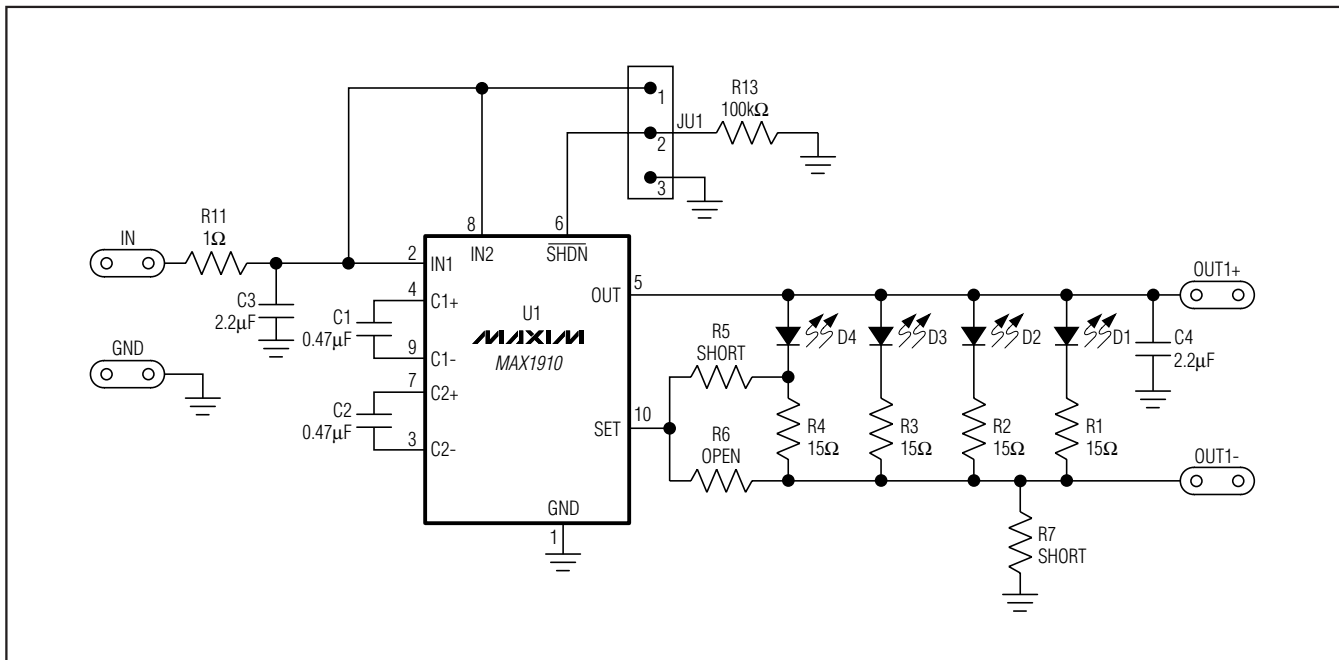

Figure 1. MAX1910 EV Kit Schematic

MAX1910 Evaluation Kit

Evaluates: MAX1910/MAX1912

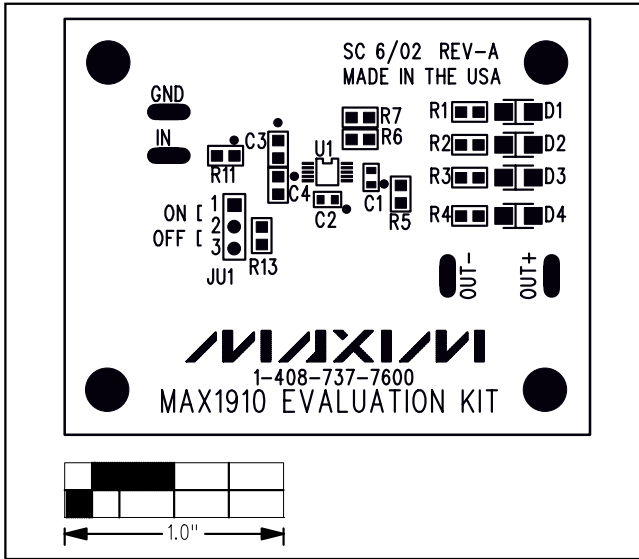

Figure 2. MAX1910 EV Kit Component Placement Guide—Component Side

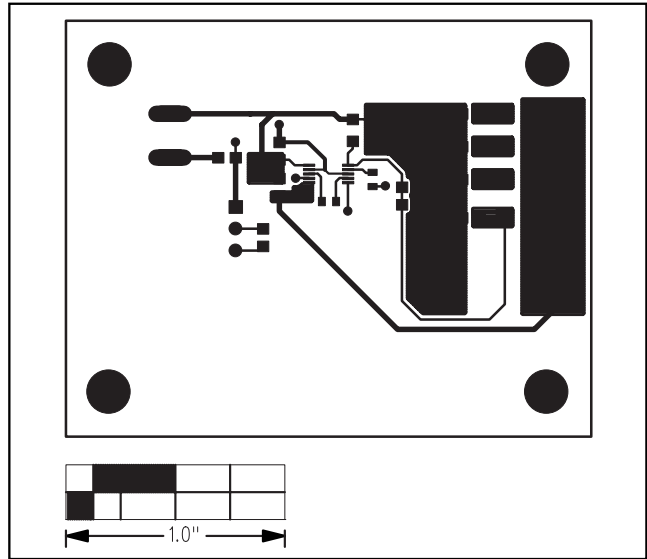

Figure 3. MAX1910 EV Kit PCB Layout—Component Side

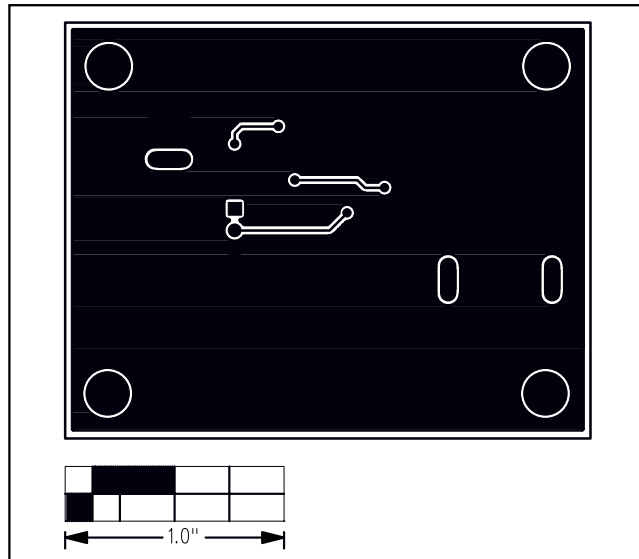

Figure 4. MAX1910 EV Kit PCB Layout—Solder Side

MAX1910 Evaluation Kit

Revision History

REVISION NUMBER	REVISION DATE	REVISION DESCRIPTION	PAGES CHANGED
0	2/03	Initial release	—
1	11/07	Updated <i>Ordering Information</i> table format, adding lead-free and RoHS-compliant part; changed part number for D1–D4 in <i>Component List</i> ; various style edits.	1–3

Evaluates: MAX1910/MAX1912

Maxim cannot assume responsibility for use of any circuitry other than circuitry entirely embodied in a Maxim product. No circuit patent licenses are implied. Maxim reserves the right to change the circuitry and specifications without notice at any time.

4 _____ **Maxim Integrated Products, 120 San Gabriel Drive, Sunnyvale, CA 94086 408-737-7600**

© 2007 Maxim Integrated Products

MAXIM is a registered trademark of Maxim Integrated Products, Inc.