



MAX1958/MAX1959 Evaluation Kit

Evaluates: MAX1958/MAX1959

General Description

The MAX1958/MAX1959 evaluation (EV) kit demonstrates an application circuit ideal for use with hetero-junction bipolar transistor power amplifiers (HBT PA). The MAX1958/MAX1959 application circuit features an 800mA DC-to-DC buck converter, an operational amplifier, and a high-accuracy temperature sensor.

The high-efficiency, dynamically adjustable, pulse-width modulated (PWM), DC-to-DC buck converter is optimized to provide power to the HBT PA in N-CDMA and W-CDMA cellular phones. The 1MHz PWM switching frequency allows the use of small external components, while skip mode reduces quiescent current to 190 μ A with light loads. The buck regulator is dynamically controlled to provide any fixed output voltage in the 0.75V to 3.4V (MAX1958) and 1V to 3.6V (MAX1959) ranges. The DC-to-DC converter utilizes a low on-resistance internal MOSFET switch and synchronous rectifier to maximize efficiency and minimize external component count.

The built-in operational amplifier is used to provide full bias control for the PA to maximize efficiency. The amplifier has Rail-to-Rail[®] input/output capability, 800kHz gain-bandwidth product, and 120dB open-loop voltage gain. An added feature of the amplifier is an active output discharge in shutdown mode.

The precision temperature sensor measures temperatures between -40°C and +125°C.

This fully tested EV kit comes with the MAX1958 IC installed. The MAX1959 has an identical pinout arrangement and can be evaluated on this board. To evaluate the MAX1959, request a free sample of the MAX1959 when ordering this evaluation kit.

Features

- ◆ **Buck Converter**
 - Dynamically Adjustable Output from 0.75V to 3.4V (MAX1958)**
 - Dynamically Adjustable Output from 1V to 3.6V (MAX1959)**
 - 1MHz Fixed-Frequency PWM**
 - 800mA Guaranteed Output Current**
 - 130mV IC Dropout at 600mA Load**
 - 16% to 100% Duty-Cycle Operation**
 - Low Quiescent Current**
 - 190 μ A (typ) in Skip Mode (MAX1958)**
 - 3mA (typ) in PWM Mode**
 - 0.01 μ A (typ) in Shutdown Mode**
 - No External Schottky Diode Required**
- ◆ **Operational Amplifier**
 - Active Output Discharge in Shutdown Mode**
 - 800kHz Gain-Bandwidth Product**
 - 120dB Open-Loop Voltage Gain ($R_L = 100k\Omega$)**
 - 5mA Rail-to-Rail Output**
- ◆ **Temperature Sensor**
 - 40°C to +125°C Rated Temperature Range**
 - Accurate Sensor, -11.64mV/°C Slope**

Ordering Information

PART	TEMP RANGE	IC PACKAGE
MAX1958EVKIT	-40°C to +85°C	20 Thin QFN

Component Suppliers

SUPPLIER	COMPONENT	PHONE	WEBSITE
Kamaya	Resistors	260-489-1533	www.kamaya.com
Murata	Capacitors	770-436-1300	www.murata.com
Sumida	Inductors	81-03-3667-3381	www.sumida.com
Taiyo Yuden	Capacitors	408-573-4150	www.t-yuden.com

Note: When contacting these component suppliers, please specify you are using the MAX1958/MAX1959.

Rail-to-Rail is a registered trademark of Nippon Motorola, Ltd.



For pricing, delivery, and ordering information, please contact Maxim/Dallas Direct! at 1-888-629-4642, or visit Maxim's website at www.maxim-ic.com.

MAX1958/MAX1959 Evaluation Kit

Component List

DESIGNATION	QTY	DESCRIPTION
C1, C3	2	4.7 μ F \pm 10%, 6.3V ceramic capacitors Taiyo Yuden JMK212BJ475KG
C2, C7	2	0.1 μ F \pm 10%, 50V X7R ceramic capacitors Taiyo Yuden EMK107BJ104KA
C4, C8, C9, C10	4	Not installed
C5	1	0.01 μ F \pm 10%, 50V X7R ceramic capacitor Taiyo Yuden UMK107 B103KZ
C6	1	560pF \pm 5%, 50V SL ceramic capacitor Murata GRM1881X1H561J
C11	1	22pF \pm 5%, 50V SL ceramic capacitor Murata GRM1881X1H220J
C12	1	100pF \pm 5%, 50V SL ceramic capacitor Murata GRM1881X1H101J
JU1	1	Jumper, SIP3, 3-pin header Digikey S1012-3-ND
JU2, JU3, JU4	3	Jumpers, SIP2, 2-pin headers Digikey S1012-2-ND
L1	1	4.7 μ H, 900mA power inductor Sumida CDRH3D16-4R7
R1	1	20 Ω \pm 5% resistor
R2	1	6.8k Ω \pm 5% resistor
R3	1	12k Ω \pm 5% resistor
R4	1	9.1k Ω \pm 5% resistor
R5, R9, R10	3	Not installed
R6, R7, R8	3	1M Ω \pm 5% resistors
R11	1	100 Ω \pm 5% resistor
None	2	BNC connectors A/D Electronics 580-002-00
U1	1	MAX1958ETP

Required Equipment

The following equipment is required before beginning:

- Three 6V (at 1A) DC power supplies or batteries
- Digital multimeter (DMM)
- Temperature gauge
- Current meter (optional)

Quick Start

The MAX1958 application circuit is fully assembled and tested. Follow these steps to verify board operation.

DC-to-DC Converter

- 1) Preset one DC power supply (PS1) to 2.6V. Turn off the power supply.
- 2) Preset the second DC power supply (PS2) to 0.43V. Turn off the power supply.
- 3) Verify that the shunt is in place at JU1 between positions 2 and 3 for normal-mode operation.
- 4) Verify that there is no shunt at JU2.
- 5) Connect the positive lead of PS1 to the VIN pad and connect the negative lead of PS1 to GND.
- 6) Connect the positive lead of PS2 to the ADJ pad and connect the negative lead of PS2 to GND5.
- 7) Connect the positive lead of the DMM to VOUT and connect the negative lead of the DMM to GND3. This DMM measures the output voltage at VOUT.
- 8) Turn on both of the power supplies (PS1 first, then PS2).
- 9) Verify that the voltage at VOUT is 0.75V.
- 10) Gradually increase the PS1 output voltage up to 4.7V verifying that the output voltage at VOUT remains at 0.75V. VOUT does not regulate to 0.75V at input voltages above 4.7V due to the minimum duty-cycle range.
- 11) Gradually increase the output of the PS2 power supply up to 1.93V verifying that the output voltage tracks the ADJ voltage at (1.76 \times V_{ADJ}). When V_{ADJ} is 1.93V, V_{OUT} should be 3.4V.
- 12) With V_{ADJ} set at 0.57V, gradually increase the output voltage of PS1 to 5.5V verifying that the VOUT output voltage remains at 1V.
- 13) Connect an 800mA load between VOUT and GND3.
- 14) Verify that the voltage at VOUT is 1V.

Operational Amplifier

MAX1958/MAX1959 Evaluation Kit

- 1) Preset one DC power supply (PS1) to 2.6V. Turn off the power supply.
- 2) Preset another DC power supply (PS3) to 1V. Turn off the power supply.
- 3) Verify that there is no shunt across JU4.
- 4) Connect the positive lead of PS1 to the VIN pad and connect the negative lead of PS1 to the GND pad.
- 5) Connect the positive lead of PS3 to the IN+ pad and connect the negative lead of PS3 to the GND4 pad.
- 6) Connect the positive lead of the DMM to AOUT. Connect the negative lead of the DMM to GND1. The DMM now measures the output voltage, AOUT.
- 7) Turn on the power supplies (PS1 first and then PS3).
- 8) Verify the output voltage at AOUT is 1.57V.
- 9) Gradually increase the output voltage of PS3 and verify that the voltage at AOUT is $(1.57 \times V_{IN+})$. V_{AOUT} cannot be higher than $(V_{IN} - 25mV)$.
- 10) Gradually increase the output voltage of PS1 up to 5.5V verifying that the output voltage remains at $(1.57 \times V_{IN+})$.

Temperature Sensor

- 1) Preset a DC power supply (PS1) to 2.6V. Turn off the power supply.
- 2) Verify that there is no shunt across JU3.
- 3) Connect the positive lead of PS1 to the VIN pad and connect the negative lead of PS1 to the GND pad.
- 4) Place the input of the temperature gauge as close to the IC as possible. For best results, solder a thermocouple to the via connected to the exposed pad on the back of the IC.
- 5) Turn on the power supply.
- 6) Measure the voltage at TOUT. Compare this voltage with the output of the temperature gauge. See the *Temperature Sensor Operation* section for the TOUT voltage calculation.

Detailed Description

Setting the Output Voltage

The MAX1958's output voltage tracks the voltage at ADJ. V_{OUT} should regulate at $1.76 \times V_{ADJ}$ for the MAX1958 and $2 \times V_{ADJ} - 0.8$ for the MAX1959.

Temperature Sensor Operation

The temperature sensor provides information about the MAX1958/MAX1959 die temperature. The voltage at TOUT (V_{TOUT}) is found as follows:

$$V_{TOUT} = (-4 \times 10^{-6} \times T^2) + (-1.13 \times 10^{-2} \times T) + 1.8708$$

This equation can be approximated with the linear function:

$$V_{TOUT} = -11.64 \frac{mV}{^{\circ}C} \times T + 1.8778$$

The temperature sensor provides accurate information about the die temperature. Additional error in the temperature output caused by die self-heating may exist. Refer to the *Temperature Sensor* section in the MAX1958/MAX1959 data sheet for more details.

Operational Amplifier Operation

The MAX1958 EV kit demonstrates the operational amplifier in the MAX1958 in a noninverting configuration with a gain of 1.57V/V. Resistors R2 and R3 can be changed to alter the noninverting gain. The following equation shows the relationship between R2 and R3 to determine gain.

$$V_{AOUT} = V_{IN+} \times \left(\frac{R2}{R3} + 1 \right)$$

Jumper Settings

Jumper JU2/JU3/JU4 Functions (Shutdown)

The MAX1958/MAX1959 feature a shutdown mode to minimize the quiescent current. Place a shunt between pins 1 and 2 on JU2 to shutdown the DC-to-DC converter. Place a shunt between pins 1 and 2 on JU4 to shutdown the operational amplifier. Place a shunt between pins 1 and 2 on JU3 to shutdown the temperature sensor. Remove the shunts for normal operation.

Jumper JU1 Function (Mode Select)

The DC-to-DC converter contained in the MAX1958/MAX1959 can be operated in two modes. Place a shunt between pins 1 and 2 on JU1 to operate in forced-PWM mode at all loads. Place a shunt between pins 2 and 3 on JU1 to operate in skip mode at light loads (<150mA) and PWM mode at medium to heavy loads. Do not leave JU1 unconnected.

MAX1958/MAX1959 Evaluation Kit

Evaluates: MAX1958/MAX1959

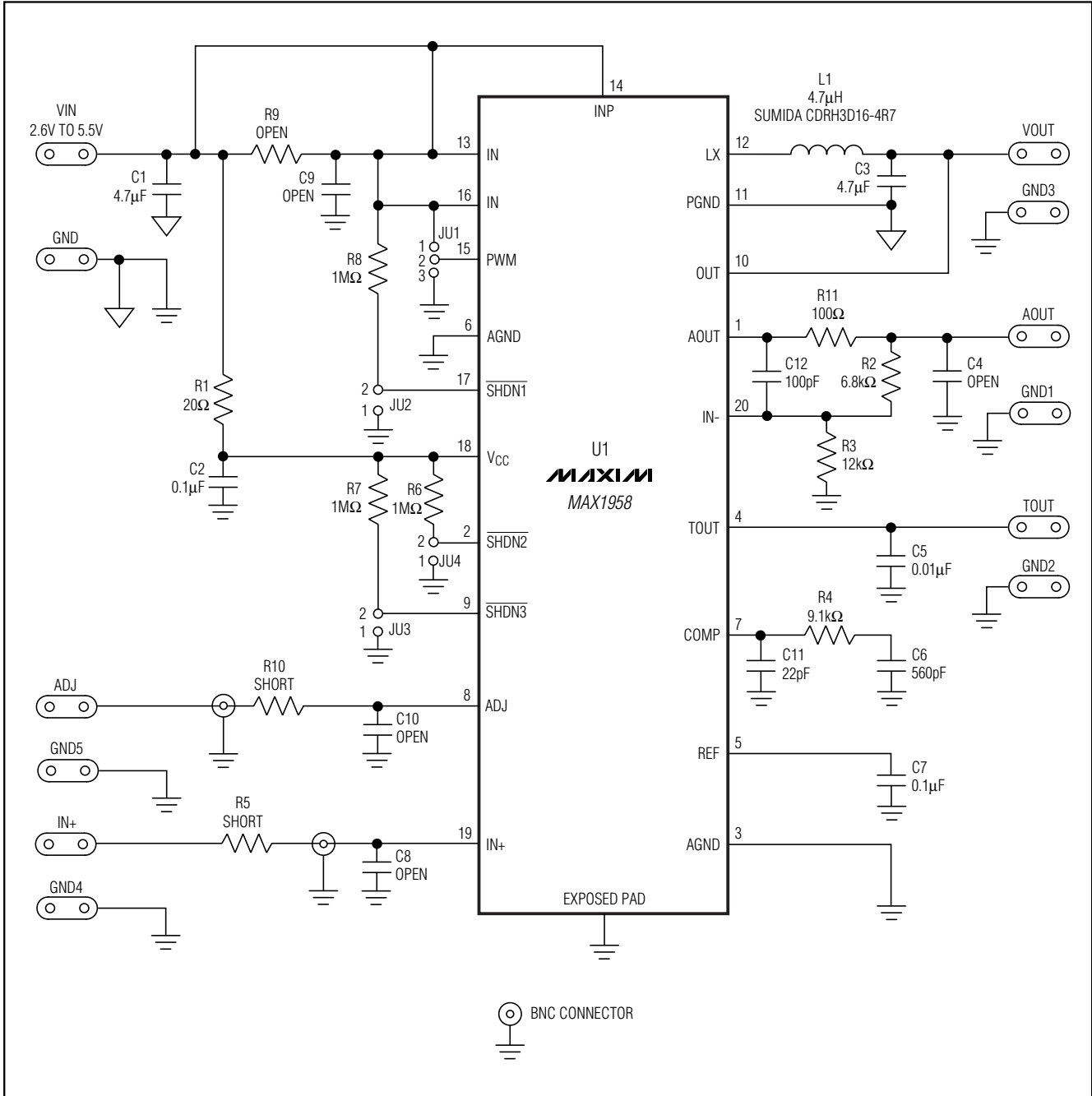

Figure 1. MAX1958/MAX1959 EV Kit Schematic

MAX1958/MAX1959 Evaluation Kit

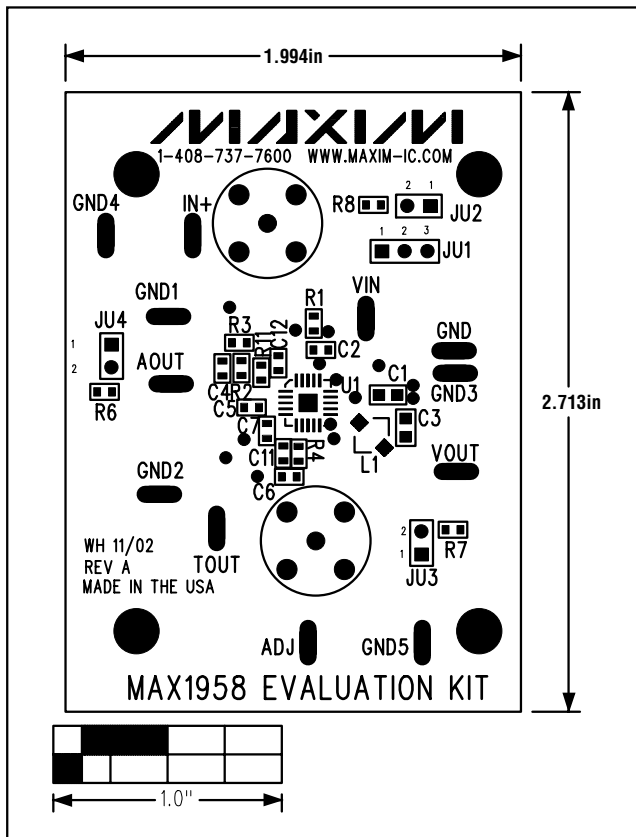

Figure 2. MAX1958 EV Kit Component Placement Guide—Top Silkscreen

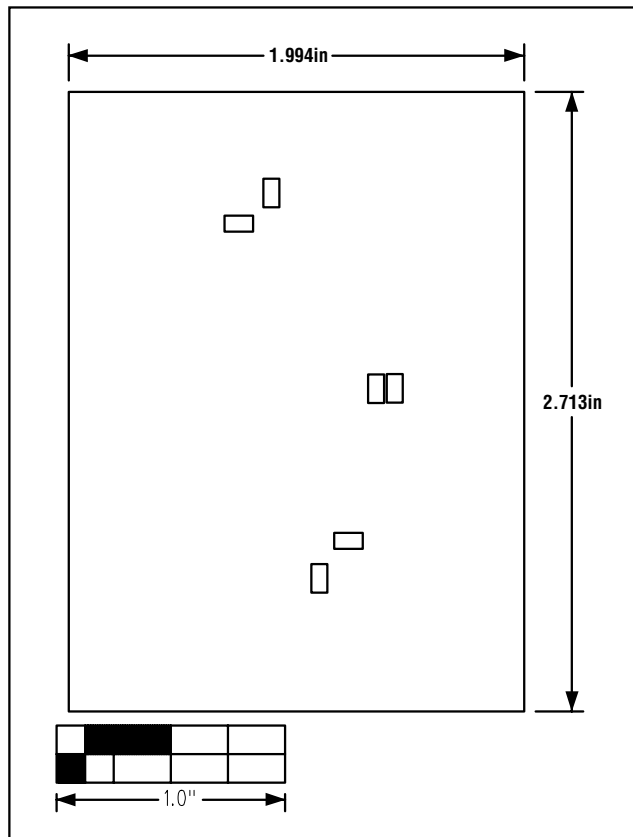

Figure 3. MAX1958 EV Kit Component Placement Guide—Back Silkscreen

Evaluates: MAX1958/MAX1959

MAX1958/MAX1959 Evaluation Kit

Evaluates: MAX1958/MAX1959

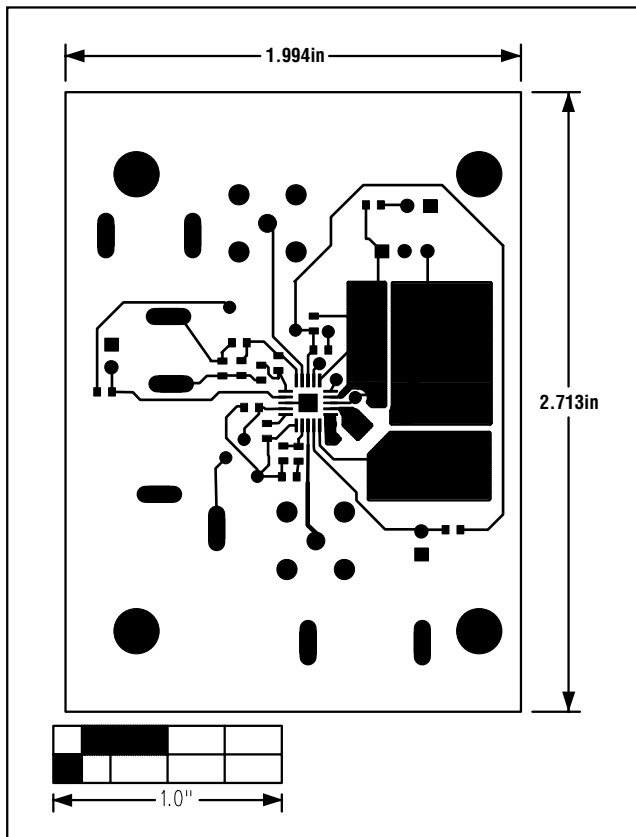

Figure 4. MAX1958 EV Kit PC Board Layout—Component Side

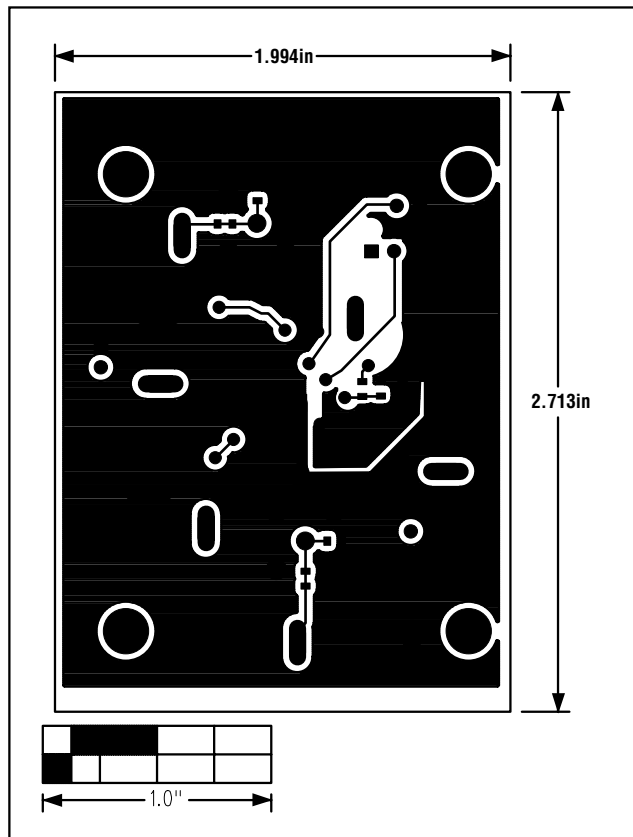

Figure 5. MAX1958 EV Kit PC Board Layout—Solder Side

Maxim cannot assume responsibility for use of any circuitry other than circuitry entirely embodied in a Maxim product. No circuit patent licenses are implied. Maxim reserves the right to change the circuitry and specifications without notice at any time.

6 _____ **Maxim Integrated Products, 120 San Gabriel Drive, Sunnyvale, CA 94086 408-737-7600**