

## General Description

The MAX20419 evaluation kit (EV kit) is a fully assembled and tested PCB that demonstrates the MAX20419ATGB/V+ power-management IC (PMIC). The EV kit includes three high-efficiency, low-voltage DC-DC converters: OUT1 boosts a 3.3V input to 5V at up to 750mA, while two synchronous step-down converters (OUT2, OUT3) provide output voltages of 2.3V and 1.25V up to 2A. The 2.2MHz switching-frequency operation allows for the use of all-ceramic capacitors and minimizes external components.

The EV kit features three on/off jumper controls and three reset outputs to indicate output status for each converter. The EV kit also provides a SYNC input to select the operating mode (PWM, skip, or external synchronization), and an open-drain power-good output ( $\overline{\text{PV\_OV}}$ ) that asserts when the input supply voltage is 3.7% above or below the target input voltage.

## Features

- 3.0V to 5.5V Operating Supply Voltage
- 5V at 750mA Synchronous Boost Converter (OUT1)
- 1.25V at 2A Synchronous Buck Converter (OUT2)
- 2.3V at 2A Synchronous Buck Converter (OUT3)
- Programmable Windowed Watchdog
- SYNC Mode Select/Input for Forced-PWM (FPWM) and Skip-Mode Selection, or External Frequency Synchronization
- Individual  $\overline{\text{RESET}}$  Outputs
- $\overline{\text{PV\_OV}}$  Input Power-Good Indicator
- Minimized External Components
- Proven PCB Layout
- Fully Assembled and Tested

[Ordering Information](#) appears at end of data sheet.

## Quick Start

### Required Equipment

- MAX20419 EV kit
- Variable 6V power supply capable of supplying 5A
- Electronic load
- Two voltmeters

### Procedure

The EV kit is fully assembled and tested. Follow the steps below to verify board operation. **Caution: Do not turn on the power supply until all connections are completed.**

- 1) Preset the power supply to 3.3V. Turn off the power supply.
- 2) Preset the electronic load to 750mA. Turn off the electronic load.
- 3) Connect the positive lead of the power supply to the VSUP PCB pad. Connect the negative lead of the power supply to the PGND PCB pad.
- 4) Connect the positive terminal of the electronic load to the VOUT1 PCB pad. Connect the negative terminal of the electronic load to the PGND1 PCB pad.
- 5) Enable the outputs (OUT1–OUT3) by installing the shunts on jumpers EN1–EN3.
- 6) Install a shunt on SYNC1 to enable FPWM operation.
- 7) Turn on the power supply.
- 8) Verify that voltage across the VOUT1 and PGND1 PCB pads is  $5\text{V} \pm 1\%$ .
- 9) Verify that voltage across the  $\overline{\text{RESET1}}$  and PGND PCB pads is 3.3V.
- 10) Turn on the electronic load.
- 11) Verify that voltage across the VOUT1 and PGND1 PCB pads is  $5\text{V} \pm 2\%$ .

- 12) Turn off the electronic load.
- 13) Remove the electronic load from the VOUT1 and PGND1 PCB pads.
- 14) Connect the positive terminal of the electronic load to the VOUT2 PCB pad. Connect the negative terminal of the electronic load to the PGND2 PCB pad. Preset the electronic load to 2A.
- 15) Verify that voltage across the VOUT2 and PGND2 PCB pads is  $2.3V \pm 2\%$ .
- 16) Verify that voltage across the  $\overline{\text{RESET2}}$  and PGND PCB pads is 3.3V.
- 17) Turn on the electronic load.
- 18) Verify that voltage across the VOUT2 and PGND2 PCB pads is  $2.3V \pm 3\%$ .
- 19) Turn off the electronic load.
- 20) Remove the electronic load from the VOUT2 and PGND2 PCB pads.
- 21) Connect the positive terminal of the electronic load to the VOUT3 PCB pad and the negative terminal of the electronic load to the PGND3 PCB pad. Preset the electronic load to 2A.
- 22) Verify that voltage across the VOUT3 and PGND3 PCB pads is  $1.25V \pm 2\%$ .
- 23) Verify that voltage across the  $\overline{\text{RESET3}}$  and PGND PCB pads is 3.3V.
- 24) Turn on the electronic load.
- 25) Verify that voltage across the VOUT3 and PGND3 PCB pads is in the range of  $1.25V \pm 3\%$ .
- 26) Turn off the electronic load.
- 27) Turn off the power supply.

## Detailed Description

The MAX20419 EV kit integrates three high-efficiency, low-voltage DC-DC converters: OUT1 is a synchronous boost converter that boosts a 3.3V input to 5.0V at up to 750mA, while two synchronous step-down converters (OUT2, OUT3) provide output voltages of 2.3V and 1.25V.

OUT1–OUT3 can be enabled/disabled by the EN1–EN3 jumpers, respectively. The status of input voltage and output voltages can be indicated by  $\overline{\text{PV\_OV}}$  and  $\overline{\text{RESET1}}-\overline{\text{RESET3}}$ .

## Operation Mode

The EV kit features a jumper (SYNC1) to configure the device operation mode. Install a shunt on SYNC1 to enter FPWM mode. Remove the shunt on SYNC1 to enable skip mode under light-load conditions. Connect an external clock with 1.8MHz to 2.6MHz frequency to synchronize the internal oscillator to an external clock. [Table 1](#) summarizes the functions of SYNC1.

## Enable Control (EN1–EN3)

The EN1–EN3 jumpers are used to enable or disable OUT1–OUT3, respectively. Install shunts on EN1, EN2, or EN3 to enable OUT1, OUT2, or OUT3 for normal operation. Remove the shunts on EN1–EN3 to enter shutdown mode. See [Table 2](#) for enable control.

**Table 1. Operation Mode (SYNC1)**

SHUNT POSITION	MODE
ON	FPWM
OFF	Skip
OFF (an external clock connected to SYNC PCB pad)	Synchronize to external clock

**Table 2. Enable Control (EN1–EN3)**

SHUNT POSITION	MODE
ON	Normal operation
OFF	Shutdown

**Reset Outputs ( $\overline{\text{RESET1}}\text{--}\overline{\text{RESET3}}$ )**

The EV kit also includes three  $\overline{\text{RESET}}_i$  outputs to monitor OUT1–OUT3. The  $\overline{\text{RESET}}_i$  output becomes high impedance and is pulled to the supply voltage when the corresponding output voltage is within the specified undervoltage/overvoltage (UV/OV) range.  $\overline{\text{RESET}}_i$  goes low when the corresponding output voltage is outside the specified UV/OV range.

**Power-Good Output ( $\overline{\text{PV\_OV}}$ )**

The EV kit provides the  $\overline{\text{PV\_OV}}$  output to monitor the supply voltage.  $\overline{\text{PV\_OV}}$  becomes low impedance when the supply voltage is 3.7% above or below its target input voltage. It can be used to disable the upstream supply when an overvoltage is detected.

**Watchdog Input (WDI)**

The EV kit features a programmable windowed watchdog that asserts  $\overline{\text{RESET}}_i$  low for  $t_{\text{HOLD}}$  when a watchdog update violation occurs. Remove the WDS jumper to evaluate the watchdog operation. See Table 3 for watchdog control. Refer to the MAX20419 IC data sheet for details.

**Table 3. Watchdog Control (WDS)**

SHUNT POSITION	MODE
ON	Disable watchdog
OFF	Enable watchdog

**Ordering Information**

PART	TYPE
MAX20419EVKIT#	EV Kit

#Denotes RoHS compliant.

## MAX20419 EV Kit Component List

DESIGNATION	QTY	DESCRIPTION
C1	1	10 $\mu$ F 16V X6S Ceramic Capacitor (0805) Murata GRT21BC81C106KE01L
C2, C3	2	47 $\mu$ F 4V X6S Ceramic Capacitor (0805) Murata GRT21BC80G476ME13L
C4	1	47 $\mu$ F 16V Aluminum Capacitor Panasonic EEEFC1C470P
C5, C6	2	4.7 $\mu$ F 16V X7R Ceramic Capacitor (1206) TDK CGA5L3X7R1C475K160AB
C7	1	1 $\mu$ F 16V X7R Ceramic Capacitor (0603) TDK C1608X7R1C105K080AC
C9, C13	2	Not Installed (0603)
C10, C14	1	Not Installed (0805)
C11	1	4.7 $\mu$ F 16V X6S Ceramic Capacitor (0603) Murata GRT188C81C475ME13D
C12	1	1nF 50V X7R Ceramic Capacitor (0603) TDK CGA3E2X7R1H102K080AA
EN1, EN2, EN3, SYNC, WDS	5	2-Pin Header 0.1" Sullins: PEC36SAAN or Equivalent
--	5	Shunt, 2 POSITION Sullins: STC02SYAN or Equivalent
L1	1	2.2 $\mu$ H Inductor TDK TFM252012ALMB2R2MTAA
L2, L3	2	1 $\mu$ H Inductor TDK TFM252012ALMA1R0MTAA
R1	1	10 $\Omega$ 1% Resistor (0603)
R8, R9, R10, R11	6	20k $\Omega$ 1% Resistor (0603)
R2, R4, R6, R7	2	0 $\Omega$ 1% Resistor (0603)
R3, R5, R12	0	Not Installed (0603)
U1	1	2.2MHz Sync Boost and Dual Step-Down Converter PMIC Maxim MAX20419ATGB/V+ (TQFN 4mm $\times$ 4mm $\times$ 0.75mm)
--	1	PCB: MAX2001419 Evaluation Kit+
--	14	Test Point without Base Keystone Electronics 5020

MAX20419 EV Kit Schematic

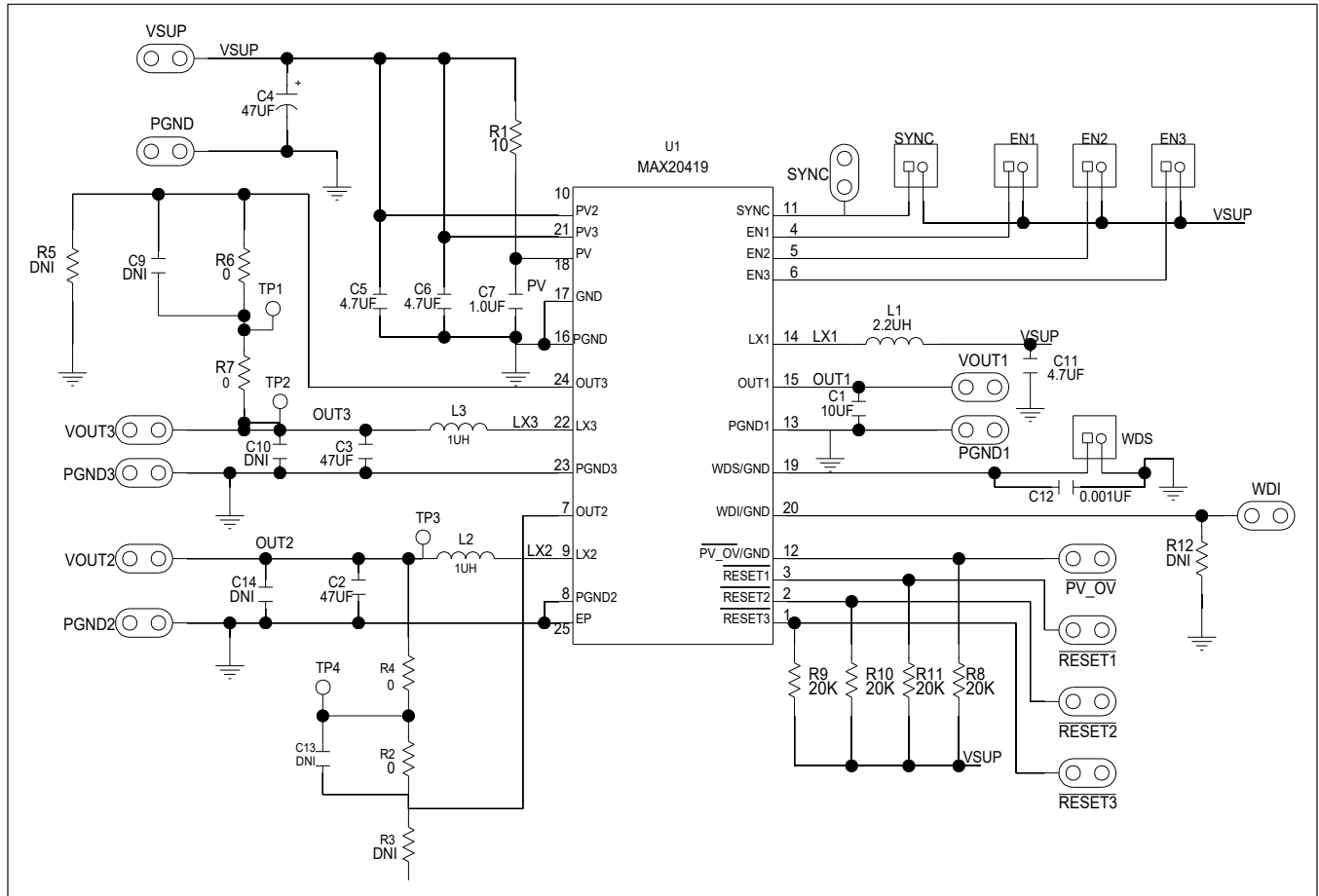

MAX20419 EV Kit PCB Layout Diagrams

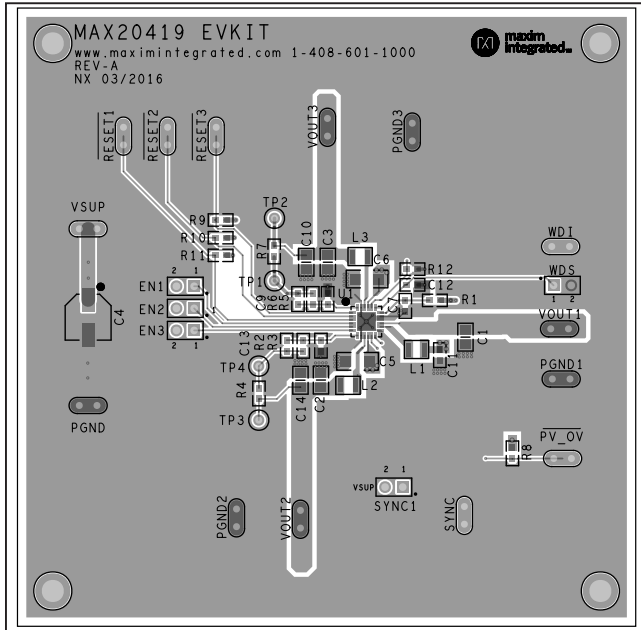

MAX20419 EV Kit Component Placement Guide---Top Layer

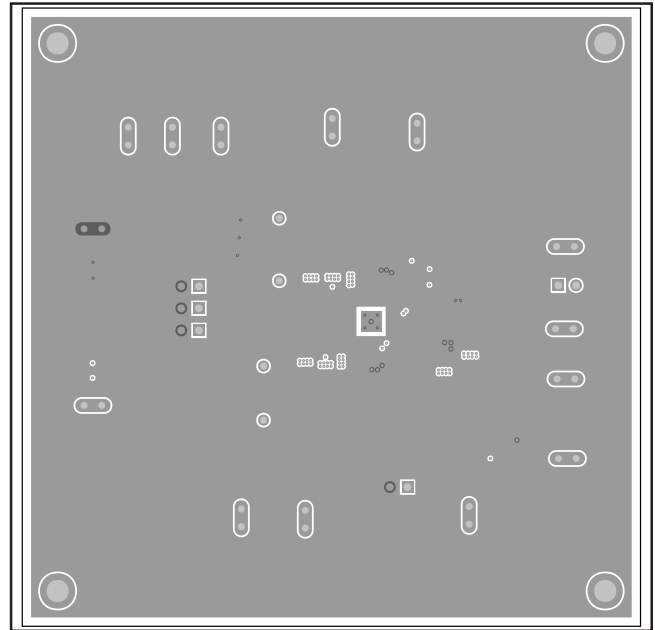

MAX20419 EV Kit PCB Layout---Layer 3 (ground layer)

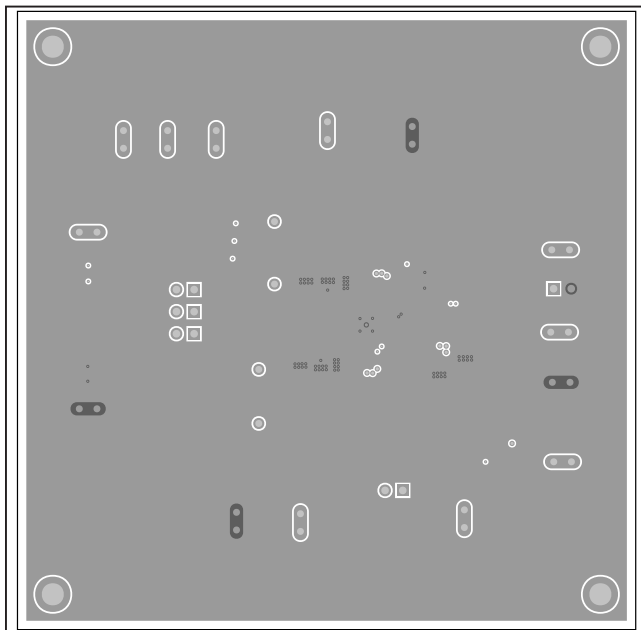

MAX20419 EV Kit PCB Layout---Layer 2 (ground layer)

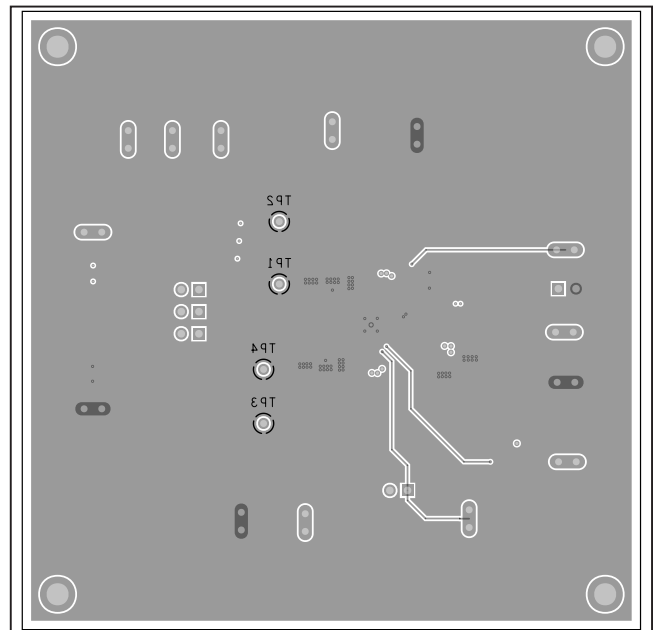

MAX20419 EV Kit Component Placement Guide---Bottom Layer

### Revision History

REVISION NUMBER	REVISION DATE	DESCRIPTION	PAGES CHANGED
0	7/18	Initial release	—

For pricing, delivery, and ordering information, please contact Maxim Direct at 1-888-629-4642, or visit Maxim Integrated's website at [www.maximintegrated.com](http://www.maximintegrated.com).

*Maxim Integrated cannot assume responsibility for use of any circuitry other than circuitry entirely embodied in a Maxim Integrated product. No circuit patent licenses are implied. Maxim Integrated reserves the right to change the circuitry and specifications without notice at any time.*