

MAX31091

Automotive Temperature Range Spread-Spectrum EconOscillator™

General Description

The MAX31091 is a low-cost clock generator that is factory trimmed to output frequencies from 200kHz to 66.6MHz with a nominal accuracy of $\pm 0.25\%$. The device can also produce a center-spread-spectrum output with pin-selectable dither magnitude and rate. Assembled in an 8-pin $\mu\text{MAX}^{\text{®}}$ package, the MAX31091 is designed to operate with a 3.0V to 3.6V power supply over the automotive temperature range (-40°C to $+125^{\circ}\text{C}$).

Applications

- Automotive Infotainment
- Navigation
- Advanced Driver Assistance System (ADAS)
- Engine Control Unit (ECU) Instrumentation
- Automotive

Typical Operating Circuit

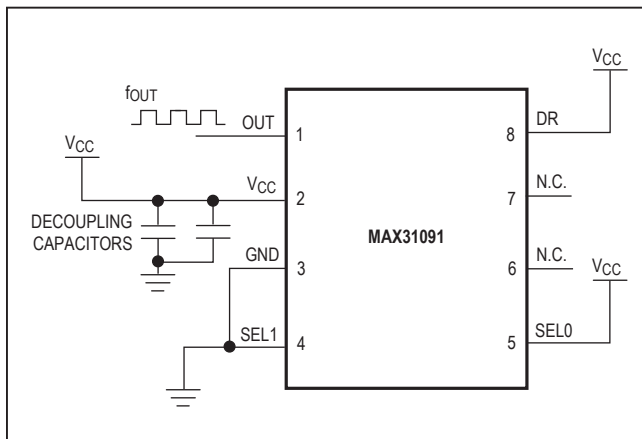

Benefits and Features

- Spread-Spectrum Clock Output from 200kHz to 66.6MHz
- -40°C to $+125^{\circ}\text{C}$ Operating Temperature Range
- $\pm 1.75\%$ Accuracy Across Temperature
- Factory Trimmed
- Center-Dithered Spread-Spectrum Output
- Pin-Selectable Center-Dither Magnitude of 0%, $\pm 1\%$, $\pm 2\%$, or $\pm 4\%$
- Pin-Selectable Dither Rate
- 3.0V to 3.6V Supply Operation
- Lead(Pb)-Free, 8-Pin μMAX Package
- AEC-Q100 Qualified

Custom Frequency Options

Contact factory for available custom frequency options.

[Ordering Information](#) appears at end of data sheet.

EconOscillator is a trademark and μMAX is a registered trademark of Maxim Integrated Products, Inc.

Absolute Maximum Ratings

Voltage Range on V_{CC} Relative to Ground-0.5V to +4.0V
 Voltage Range on DR, SEL0, SEL1
 Relative to Ground.....-0.5V to (V_{CC} + 0.5V)*
 Continuous Power Dissipation (T_A = +70°C)
 μMAX (derate 4.8mW/°C above +70°C)390mW

Operating Temperature Range..... -40°C to +125°C
 Storage Temperature Range -55°C to +125°C
 Lead Temperature (soldering, 10s) +300°C
 Soldering Temperature (reflow) +260°C

*This voltage must not exceed 4.0V.

Stresses beyond those listed under “Absolute Maximum Ratings” may cause permanent damage to the device. These are stress ratings only, and functional operation of the device at these or any other conditions beyond those indicated in the operational sections of the specifications is not implied. Exposure to absolute maximum rating conditions for extended periods may affect device reliability.

Package Information

8 μMAX

PACKAGE CODE	U8+4
Outline Number	21-0036
Land Pattern Number	90-0092
Thermal Resistance, Multi-Layer Board:	
Junction to Ambient (θ _{JA})	206°C/W
Junction to Case (θ _{JC})	42°C/W

For the latest package outline information and land patterns (footprints), go to www.maximintegrated.com/packages. Note that a “+”, “#”, or “-” in the package code indicates RoHS status only. Package drawings may show a different suffix character, but the drawing pertains to the package regardless of RoHS status.

Package thermal resistances were obtained using the method described in JEDEC specification JESD51-7, using a four-layer board. For detailed information on package thermal considerations, refer to www.maximintegrated.com/thermal-tutorial.

Recommended Operating Conditions

($T_A = -40^\circ\text{C}$ to $+125^\circ\text{C}$, unless otherwise noted.)

PARAMETER	SYMBOL	CONDITIONS	MIN	TYP	MAX	UNITS
Supply Voltage	V_{CC}	(Note 1)	3.0	3.3	3.6	V
High-Level Input Voltage (SEL0, SEL1, DR)	V_{IH}		$0.7 \times V_{CC}$		$V_{CC} + 0.3$	V
Low-Level Input Voltage (SEL0, SEL1, DR)	V_{IL}		-0.3		$0.3 \times V_{CC}$	V

DC Electrical Characteristics

($V_{CC} = +3.0\text{V}$ to $+3.6\text{V}$, $T_A = -40^\circ\text{C}$ to $+125^\circ\text{C}$, unless otherwise noted.)

PARAMETER	SYMBOL	CONDITIONS	MIN	TYP	MAX	UNITS
High-Level Output Voltage (OUT)	V_{OH}	$I_{OH} = -4\text{mA}$, $V_{CC} = 3.0\text{V}$	2.4			V
Low-Level Output Voltage (OUT)	V_{OL}	$I_{OL} = 4\text{mA}$			0.4	V
High-Level Input Current (SEL0, SEL1, DR)	I_{IH}	$V_{CC} = 3.6\text{V}$			1	μA
Low-Level Input Current (SEL0, SEL1, DR)	I_{IL}	$V_{IL} = 0\text{V}$	-1			μA
Supply Current (Active)	I_{CC}	(Note 2)			16	mA

AC Electrical Characteristics

($V_{CC} = +3.0\text{V}$ to $+3.6\text{V}$, $T_A = -40^\circ\text{C}$ to $+125^\circ\text{C}$, unless otherwise noted.)

PARAMETER	SYMBOL	CONDITIONS	MIN	TYP	MAX	UNITS
Output Frequency Range	f_{OUT}	(Note 3)	0.200		66.6	MHz
Output Center Frequency Tolerance	Δf_{OUT}	$V_{CC} = 3.3\text{V}$, $T_A = +25^\circ\text{C}$	-0.25	0	+0.25	%
		Across T_A and $V_{CC} = 3.3\text{V}$	-1.75		+1.75	
		0°C to $+70^\circ\text{C}$ and $V_{CC} = 3.3\text{V}$	-1.2		+1.2	
Power-Up Time	t_{PU}	(Note 4)			0.1	ms
Load Capacitance	CL			15	50	pF
Duty Cycle		< 33.3MHz (Note 3)		50		%
		$\geq 33.3\text{MHz}$ (Note 3)	40		60	
Jitter (RMS), 50MHz				0.3		%

Note 1: All voltages are referenced to ground. Currents entering the IC are specified positive and currents exiting the IC are negative.

Note 2: Supply current measured with $C_L = 15\text{pF}$, $V_{CC} = 3.6\text{V}$, $T_A = +25^\circ\text{C}$, $f_{OUT} = 66.6\text{MHz}$, no dither.

Note 3: No dither.

Note 4: Guaranteed by design.

Note 5: For aging characteristics, contact factory.

Typical Operating Characteristics (continued)

($V_{CC} = 3.3V$, $T_A = +25^\circ C$, unless otherwise noted.)

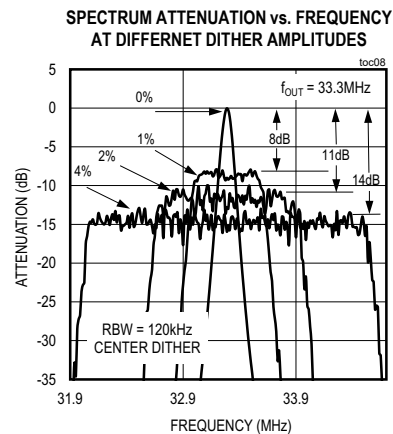
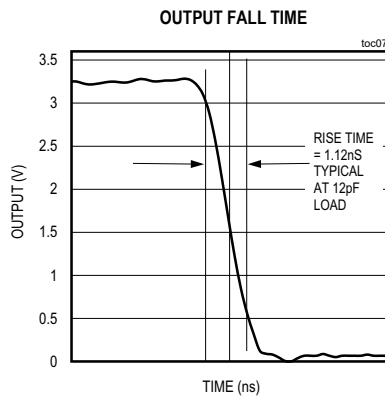
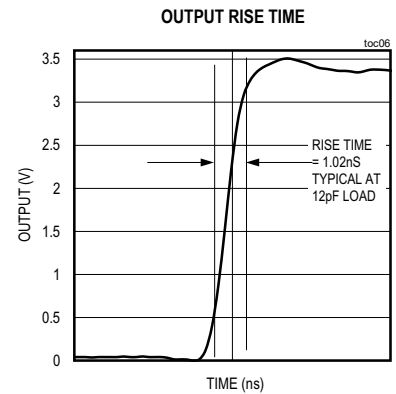
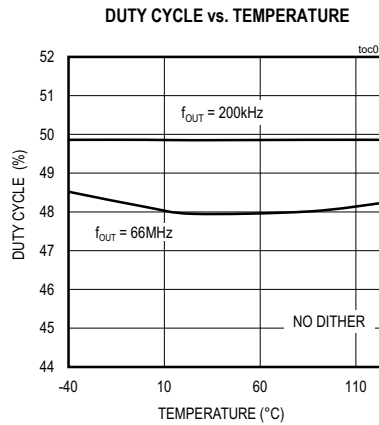
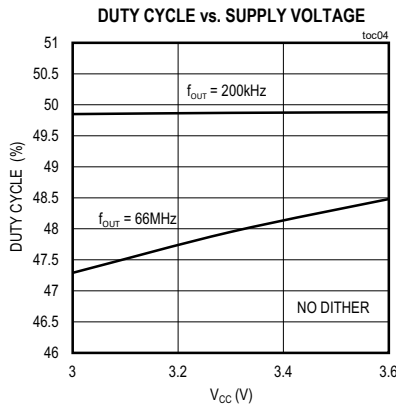
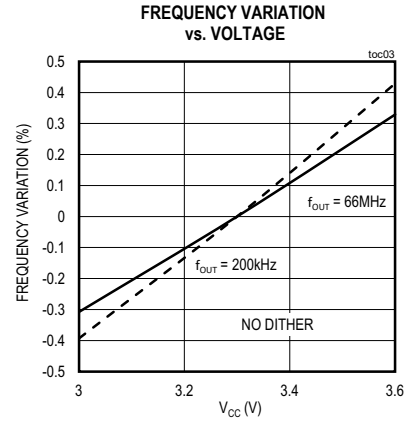
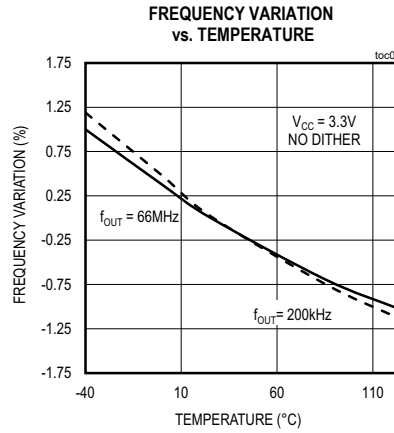
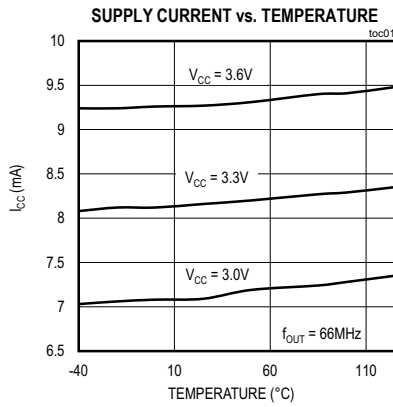

Pin Configuration

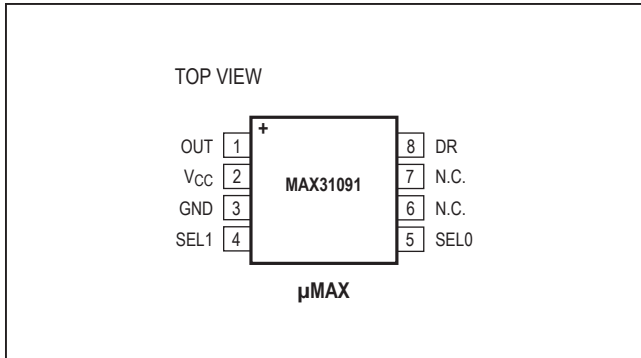

Pin Description

PIN	NAME	FUNCTION
1	OUT	Spread-Spectrum Clock Output
2	VCC	Supply Voltage
3	GND	Ground
4	SEL1	Spread-Spectrum Dither Magnitude Select Inputs. Selects dither magnitude (see Table 1).
5	SEL0	
6, 7	N.C.	No Connection
8	DR	Spread-Spectrum Dither Rate Selector. Selects dither rate (see Table 2).

Block Diagram

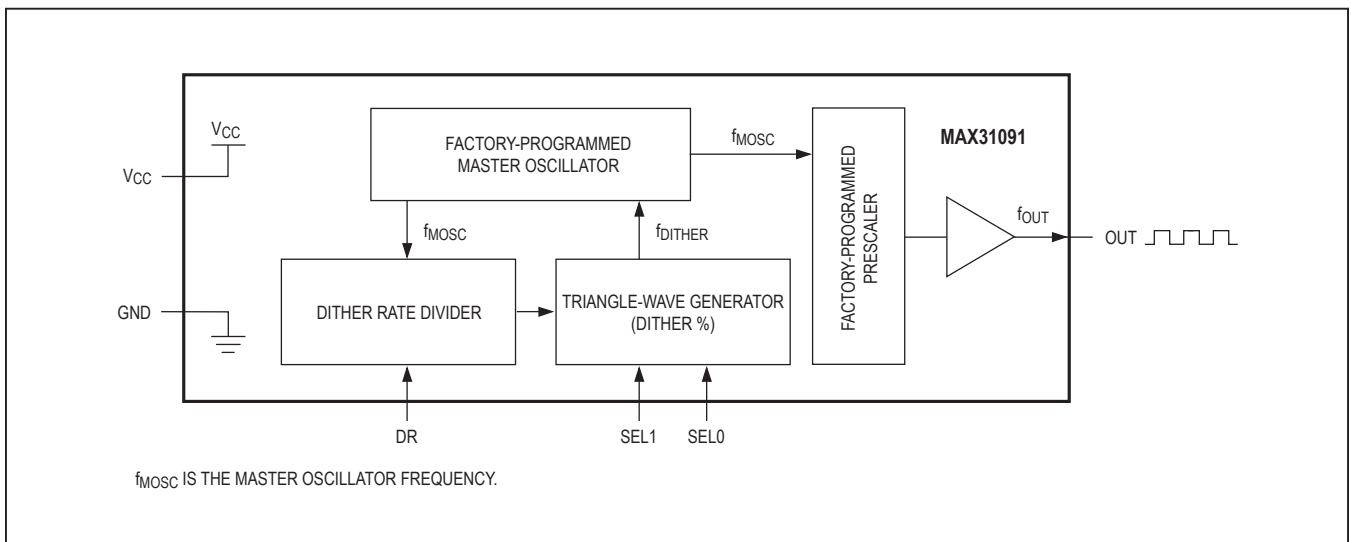

Detailed Description

The MAX31091 clock generator is capable of output frequencies from 200kHz to 66.6MHz over the full automotive temperature range (-40°C to +125°C). The device can also produce a spread-spectrum (dithered) square-wave output using four pin-selectable dither percentages. The device also features two selectable dither rates.

The MAX31091 is shipped from the factory-programmed to a customer-specified frequency.

Spread Spectrum

The MAX31091 can reduce radiated emission peaks. The dither percentage is controlled by the state of the SEL0 and SEL1 pins. The output frequency can be dithered at 0%, ±1%, ±2%, and ±4%, centered around the programmed frequency.

The two select pins SEL0 and SEL1 provide a means of selecting the dither magnitudes as follows:

A triangle-wave generator injects a control signal into the master oscillator to dither its output. The dither rate is a function of the output frequency, f_{OUT} , as well as the setting of the DR pin (see the equation below). [Figure 1](#) shows a plot of the output frequency vs. time.

$$DITHER\ RATE = \frac{f_{OUT}}{2^n}$$

where n is defined in [Table 2](#) as a function of output frequency. For example, for an output frequency of 27.0MHz, the dither rate would be 13.2kHz for DR = 1 and 6.6kHz for DR = 0.

Power-Up

Upon the application of power, the MAX31091 output is held in the low state until t_{PU} has elapsed. This removes any possibility of erroneous output transitions during initial power-up.

Table 1. Dither Magnitude

SEL1 LOGIC LEVEL	SEL0 LOGIC LEVEL	DITHER MAGNITUDE (%)
		MAX31091AUA
0	0	No dither
0	1	Q1
1	0	Q2
1	1	Q4

Table 2. Value of n w.r.t. Output Frequency

OUTPUT FREQUENCY f_{OUT} (MHz)		n	
f_{OUT} (min)	f_{OUT} (max)	DR = LOGIC LEVEL 1	DR = LOGIC LEVEL 0
0.200	0.260	4	5
0.261	0.521	5	6
0.522	1.042	6	7
1.043	2.083	7	8
2.084	4.167	8	9
4.168	8.333	9	10
8.334	16.667	10	11
16.668	33.333	11	12
33.334	66.667	12	13

MAX31091 Frequency Spreading Profile as a Function of Dither %

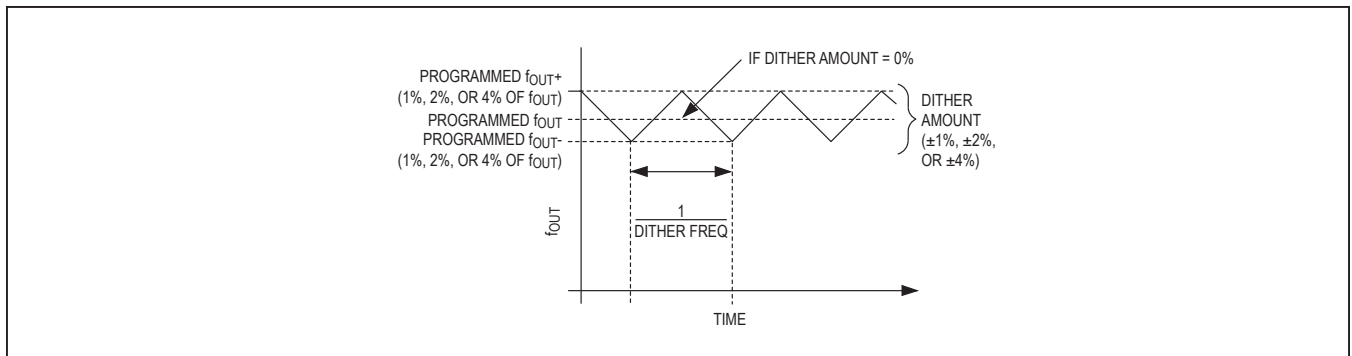

Figure 1. Center Dithered

Applications Information

Power-Supply Decoupling

To achieve best results, it is highly recommended that decoupling capacitors are used on the IC power-supply pins. Typical values of decoupling capacitors are 0.01µF and 0.1µF. Use a high-quality, ceramic, surface-mount capacitor, and mount it as close as possible to the V_{CC} and GND pins of the IC to minimize lead inductance.

Chip Information

SUBSTRATE CONNECTED TO GROUND

Ordering Information

PART	TEMP RANGE	SPREAD SPECTRUM	OUTPUT FREQUENCY (MHz)	PIN-PACKAGE
MAX31091AUA/V+033	-40°C to +125°C	Center	33.3	8 µMAX
MAX31091AUA/V+T033	-40°C to +125°C	Center	33.3	8 µMAX
MAX31091AUA/V+066	-40°C to +125°C	Center	66.6	8 µMAX
MAX31091AUA/V+T066	-40°C to +125°C	Center	66.6	8 µMAX
MAX31091AUA/V+172	-40°C to +125°C	Center	1.7	8 µMAX
MAX31091AUA/V+T172	-40°C to +125°C	Center	1.7	8 µMAX
MAX31091AUA/V+200	-40°C to +125°C	Center	0.20	8 µMAX
MAX31091AUA/V+T200	-40°C to +125°C	Center	0.20	8 µMAX
MAX31091AUA/V+330	-40°C to +125°C	Center	33.0	8 µMAX
MAX31091AUA/V+T330	-40°C to +125°C	Center	33.0	8 µMAX
MAX31091AUA/V+192	-40°C to +125°C	Center	1.9	8 µMAX
MAX31091AUA/V+T192	-40°C to +125°C	Center	1.9	8 µMAX
MAX31091AUA/V+400	-40°C to +125°C	Center	0.4	8 µMAX
MAX31091AUA/V+T400	-40°C to +125°C	Center	0.4	8 µMAX
MAX31091AUA/V+027	-40°C to +125°C	Center	27	8 µMAX
MAX31091AUA/V+T027	-40°C to +125°C	Center	27	8 µMAX

/V denotes an automotive qualified part.

+Denotes a lead(Pb)-free/RoHS-compliant package.

T = Tape and reel.

Package Information

For the latest package outline information and land patterns (footprints), go to www.maximintegrated.com/packages. Note that a "+", "#", or "-" in the package code indicates RoHS status only. Package drawings may show a different suffix character, but the drawing pertains to the package regardless of RoHS status.

PACKAGE TYPE	PACKAGE CODE	OUTLINE NO.	LAND PATTERN NO.
8 µMAX	U8+4	21-0036	90-0092

Revision History

REVISION NUMBER	REVISION DATE	DESCRIPTION	PAGES CHANGED
0	3/14	Initial release	—
1	9/17	Added AEC-Q100 statement to <i>Benefits and Features</i> section, updated <i>General Description</i> and updated <i>Ordering Information</i> table	1, 7
2	11/18	Updated <i>Applications</i> , <i>Absolute Maximum Ratings</i> , and <i>Ordering Information</i> , added <i>Package Information</i> section	1, 2, 7

For pricing, delivery, and ordering information, please visit Maxim Integrated's online storefront at <https://www.maximintegrated.com/en/storefront/storefront.html>.

Maxim Integrated cannot assume responsibility for use of any circuitry other than circuitry entirely embodied in a Maxim Integrated product. No circuit patent licenses are implied. Maxim Integrated reserves the right to change the circuitry and specifications without notice at any time. The parametric values (min and max limits) shown in the Electrical Characteristics table are guaranteed. Other parametric values quoted in this data sheet are provided for guidance.