

MAXIM

MAX4364 Evaluation Kit

Evaluates: MAX4364

General Description

The MAX4364 evaluation kit (EV kit) is a fully assembled and tested circuit board that uses the MAX4364 high-power bridged amplifier to drive loudspeakers in portable audio applications. Designed to operate from a 2.7VDC to 5.5VDC power supply, the MAX4364 EV kit is capable of delivering 1.4W into an 8Ω load.

Component List

DESIGNATION	QTY	DESCRIPTION
C1	1	0.1μF ±10%, 16V X7R ceramic capacitor (0603) Taiyo Yuden EMK107BJ104KA
C2	1	10μF ±20%, 6.3V X5R ceramic capacitor (1206) Taiyo Yuden JMK316BJ106ML
C3	1	1.0μF ±10%, 6.3V X5R ceramic capacitor (0603) Taiyo Yuden JMK107BJ105KA
C4	1	0.47μF, 35V tantalum capacitor (case B) Kemet T491B474K035AS
C5	0	Not installed (0603)
IN	1	Right-angle phono jack (red)
JU1	1	2-pin header
R1, R2, R3	3	20kΩ ±1% resistors (0805)
R4	1	100kΩ ±5% resistor (0805)
None	1	Shunt (JU1)
None	1	MAX4364 PC board
None	1	MAX4364 data sheet
None	1	MAX4364 EV kit data sheet
U1	1	MAX4364ESA (8-pin SO)

Features

- ◆ 2.7V to 5.5V Single-Supply Operation
- ◆ Drives 1.4W into an 8Ω Speaker
- ◆ 0.04% THD + N at 1kHz
- ◆ Externally Adjustable Gain
- ◆ Clickless/Popless Power-Up/Down, Shutdown
- ◆ 10nA Shutdown Current
- ◆ Small 8-Pin SO Package
- ◆ Fully Assembled and Tested

Ordering Information

PART	TEMP RANGE	IC PACKAGE
MAX4364EVKIT	0°C to +70°C	8 SO

Quick Start

The MAX4364 EV kit is fully assembled and tested. Follow the steps listed below to verify board operation. **Do not turn on the power supply until all connections are completed.**

Recommended Equipment

- 5V, 1A power supply
- 8Ω speaker
- Audio source (e.g., CD player, tape player)

Setup

- 1) Verify that jumper JU1 (SHDN) does not have a shunt installed.
- 2) Connect the 8Ω speaker across the OUT+ and OUT- pads.
- 3) Connect an audio source to Jack J1 (IN).
- 4) Connect the 5V terminal of the power supply to the VCC pad and the ground terminal of the power supply to the GND pad.
- 5) Turn on the power supply.
- 6) Turn on the audio source.

MAX4364 Evaluation Kit

Component Suppliers

SUPPLIER	PHONE	FAX	WEBSITE
Kemet	864-963-6300	864-963-6322	www.kemet.com
Taiyo Yuden	800-348-2496	847-925-0899	www.t-yuden.com

Note: Please indicate that you are using the MAX4364 when contacting these component suppliers.

Detailed Description

The MAX4364 EV kit contains the MAX4364 high-power bridged amplifier, designed to drive loudspeakers in portable audio applications. The MAX4364 EV kit operates from a DC power supply that can provide 2.7V to 5.5V and 1A of current. The MAX4364 EV kit can accept audio source inputs (IN) with peak-to-peak amplitudes up to V_{CC} . The audio source is amplified to drive 1.4W into an 8Ω speaker.

The MAX4364 EV kit has positive and negative differential outputs that are 180° out of phase and are DC offset to $V_{CC}/2$. This allows the voltage at the load to see a peak voltage of almost V_{CC} . The closed-loop gain of the MAX4364 EV kit is configured for 2V/V, but can be reconfigured to other gains. Refer to the *Gain-Setting Resistors* section of the MAX4364/MAX4365 data sheet. However, if the closed-loop gain is reconfigured to greater than 10, a feedback capacitor, C5, can be added to limit the bandwidth, or to compensate for stray capacitance at the inverting input.

Jumper Selection

Shutdown

Jumper JU1 controls the shutdown pin (SHDN) of the MAX4364. The shutdown function can be activated on the MAX4364 EV kit by installing a shunt across the pins of JU1. The shutdown function can also be controlled by an external source connected to the SHDN pad and removing the shunt on JU1 (see Table 1 for shunt positions). **Note:** When measuring supply current in shutdown mode, the bias through resistor R1 and JU1 must be taken into account. The shutdown current can be calculated by the following equation:

$$I_{SUPPLY} = I_{RES} + I_{MAX4364}$$

$$I_{RES} = V_{CC} / R1$$

Table 1. JU1 Jumper Selection

JUMPER	SHUNT POSITION	EV KIT FUNCTION
JU1	Installed (SHDN = high)	Shutdown mode
	None (SHDN = low)	EV kit enabled
	None. External controller connected to SHDN pad (TTL/CMOS input).	SHDN driven by external controller. Shutdown is active high.

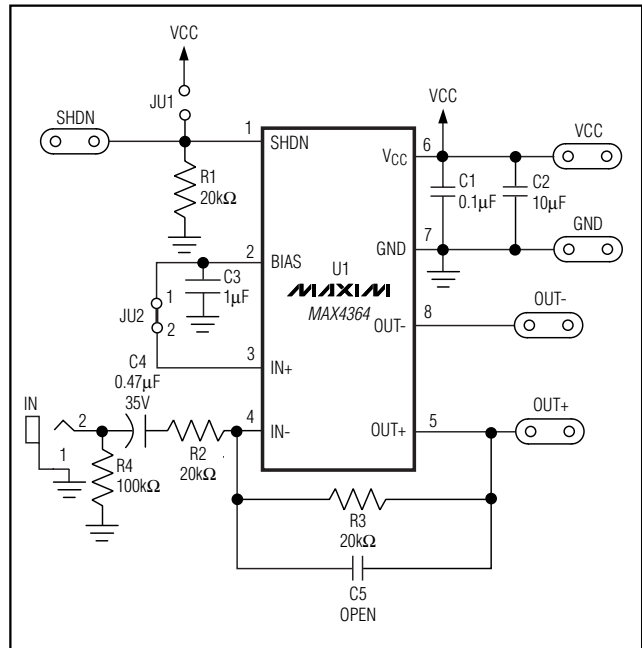

Figure 1. MAX4364 EV Kit Schematic

MAX4364 Evaluation Kit

Evaluates: MAX4364

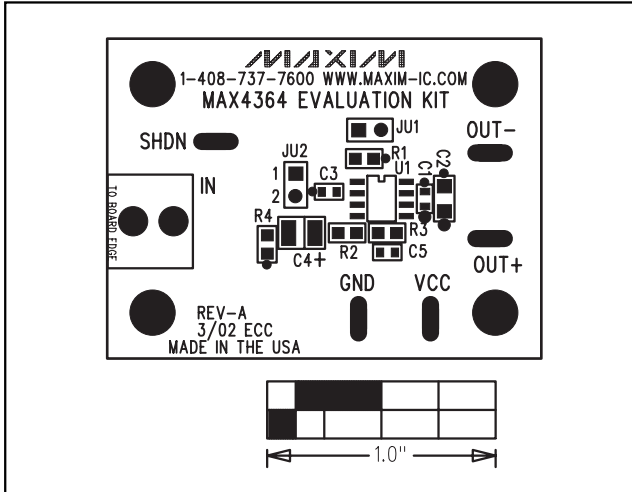

Figure 2. MAX4364 EV Kit Component Placement Guide—Component Side

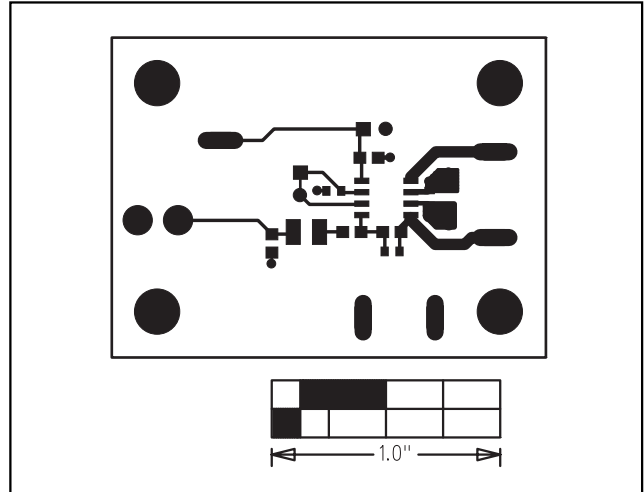

Figure 3. MAX4364 EV Kit PC Board Layout—Component Side

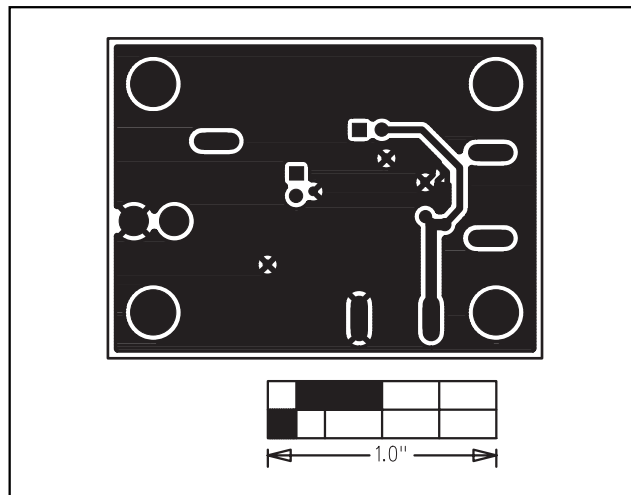

Figure 4. MAX4364 EV Kit PC Board Layout—Solder Side

Maxim cannot assume responsibility for use of any circuitry other than circuitry entirely embodied in a Maxim product. No circuit patent licenses are implied. Maxim reserves the right to change the circuitry and specifications without notice at any time.

Maxim Integrated Products, 120 San Gabriel Drive, Sunnyvale, CA 94086 408-737-7600 3