

# MAXIM

## MAX797 Evaluation Kit

### General Description

The MAX797 evaluation kit (EV kit) is a preassembled and tested demonstration board that embodies the standard 3.3V application circuit. The board comes configured to accept battery voltages between 4.5V and 28V, but can be reconfigured for voltages between 4.5V and 30V by substituting MOSFETs with higher breakdown voltage ratings.

The standard board is guaranteed to deliver at least 3A of load current. To modify the load-current capability, change the sense-resistor (R1) value and re-size the external components according to Table 1 in the MAX796/MAX797/MAX799 data sheet.

The main output voltage comes preset to 3.35V (nominal). To select 5V operation, move jumper J3 to position 1-2. For operation in adjustable mode, install resistors R4 & R5 and remove the jumper. **There is a small PC trace jumper that shunts J3 on the board. This default jumper must be cut apart for either adjustable-mode or fixed 5V operation.** Don't operate the circuit if a jumper or resistor divider has not been installed, as this will damage the IC due to output over-voltage.

In addition to the standard components, the EV kit has some extra pull-up and pull-down resistors (R4–R8) to set default logic input levels. These resistors can usually be omitted in the final design.

### Features

- ◆ **Battery Range: 4.5V to 28V**
- ◆ **Load Capability: 3.3V at 3A**
- ◆ **Adjustable 2.5V to 6V Output (optional resistor divider)**
- ◆ **Precision 2.505V Reference Output**
- ◆ **Oscillator SYNC Input**
- ◆ **Low-Noise Mode Control Input**

### Ordering Information

EV KIT	V <sub>OUT</sub>	BOARD TYPE
MAX797EVKIT-SO	+3.3V or Adj	Surface Mount

### MAX797 EV Kit



Evaluates: MAX797

# MAX797 Evaluation Kit

## Component List

DESIGNATION	QTY	DESCRIPTION
C1, C11	2	22 $\mu$ F, 35V low-ESR capacitors AVX TPSE226M035R0300 Sprague 595D226X0035R2T
C2	1	Kemet T510 X 477(1) 006 AS 470 $\mu$ F, 0.030 $\Omega$ low-ESR capacitor
C3, C8	2	0.1 $\mu$ F ceramic capacitors
C4	1	4.7 $\mu$ F, 16V tantalum capacitors Sprague 595D475X0016A2T
C5	1	0.33 $\mu$ F ceramic capacitor
C6	1	0.01 $\mu$ F ceramic capacitor
C21	0	Open
D1	1	100mA, 30V Schottky diode Central Semiconductor CMPSH-3 Motorola MBR0530
D2	1	1A, 40V Schottky diode Motorola MBRS140T3 Nihon EC10QS04 International Rectifier 10BQ040
J1, J2	2	2-pin headers
J3, J4	0	Leave these sites open
L1	1	10 $\mu$ H, 2A inductor Sumida CDRH-125-100 (shielded) Coiltronics UP2-100 Coilcraft DO3316-103
Q1, Q2	2	5A, 30V logic-level N-channel MOSFETs Motorola MMSF5N03HD International Rectifier IRF7201 Siliconix Si9410
R1	1	0.025 $\Omega$ sense resistor Dale WSL-2010-R025-F IRC LR2010-R025-F
R2, R3	0	Unused reference designators
R4, R5	0	Leave these sites open
R6, R8	2	1M $\Omega$ , 5% resistors
R7	1	100k $\Omega$ , 5% resistor
U1	1	Maxim MAX797CSE

See Table 2 in the MAX796/MAX797/MAX799 data sheet for component supplier phone/fax numbers.

## Quick Start

- 1) Connect a stiff (20W or better) bench power supply to the VIN and GND pads found at the edge of the board.
- 2) Check that the jumpers are set correctly (J1 and J2 installed, J3 set to position 2-3, J4 set to 1-2).
- 3) Turn up the input voltage to somewhere between 4.75V and 28V.
- 4) Verify that the main output is regulating at 3.3V. Normal full-load regulation is -2.5% while keeping the output in tolerance. If the measured error is higher, there may be drops in the wiring or ground.
- 5) Ensure that the voltmeter is sensing directly at the output and ground pads of the PC board.

To observe normal PWM switching action, place a 1A load on the main output and observe the switching node (device LX pin) with an oscilloscope while varying the input voltage. Without a load, the switching waveforms are intermittent and difficult to trigger on, and it may appear that the board is not working.

Jumper J4 comes installed for 300kHz operation. Component values may need to be changed if 150kHz operation is selected; see the *Design Procedure* section in the MAX796/MAX797/MAX799 data sheet. The oscillator can be synchronized to an external clock signal by driving the SYNC pad with a pulse train of 5V amplitude.

**Table 1. Pull-Up/Down Resistors**

RESISTOR	FUNCTION
R4, R5	Adjustable-mode resistor dividers, not installed. $V_{OUT} = 2.505V (1 + R4/R5)$ .
R6	1M $\Omega$ , low-noise-mode pull-up resistor, usually shorted out (SKIP to GND).
R7	100k $\Omega$ SYNC pull-up resistor, usually shorted out (SYNC to REF).
R8	1M $\Omega$ SHDN pull-down resistor, usually shorted out (SHDN to V+).

**Table 2. Jumper Connections**

JUMPER	FUNCTION
J1	On/off control. Remove to force shutdown mode.
J2	Low-noise mode select. Remove to force low-noise mode.
J3	Output voltage select. Install in position 1-2 for 5V, 2-3 for 3.3V.
J4	Frequency select. Install in position 1-2 for 300kHz, 2-3 for 150kHz.

# MAX797 Evaluation Kit

Evaluates: MAX797

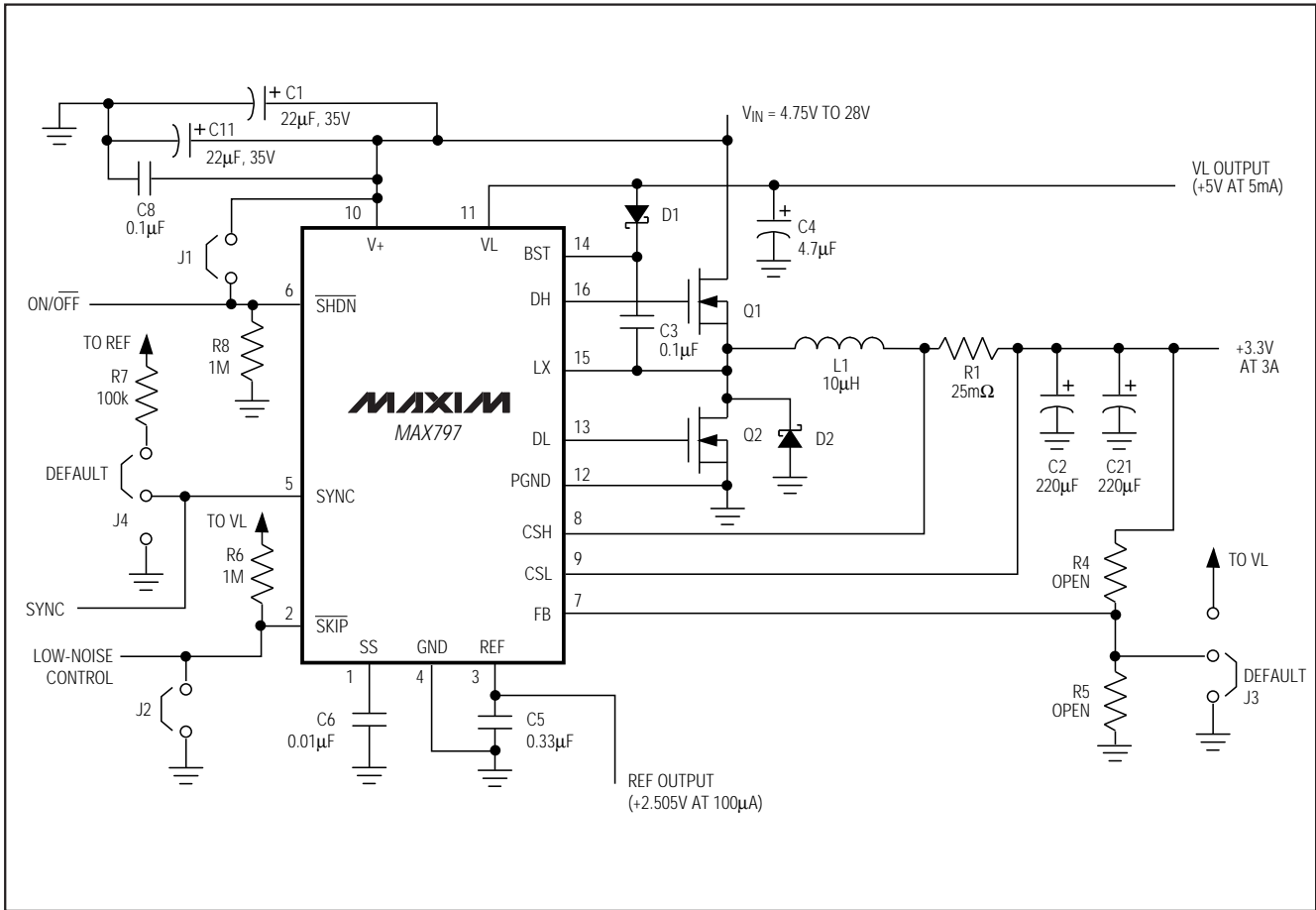

Figure 1. MAX797 EV Kit Schematic

# MAX797 Evaluation Kit

Evaluates: MAX797

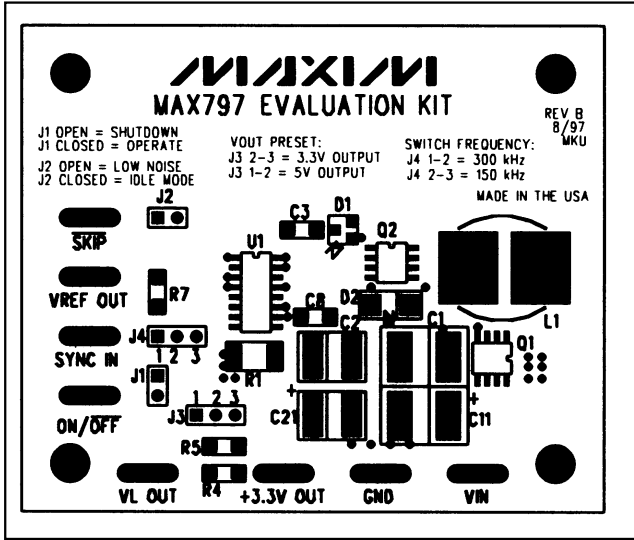

Figure 2. MAX797 EV Kit Component Placement Guide—Component Side

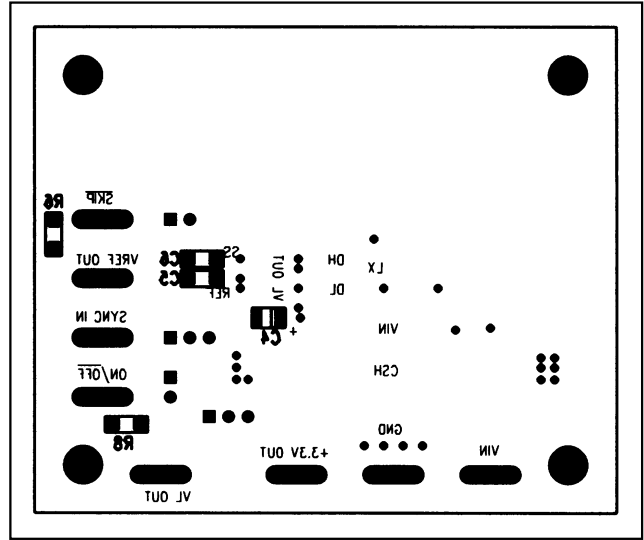

Figure 3. MAX797 EV Kit Component Placement Guide—Solder Side

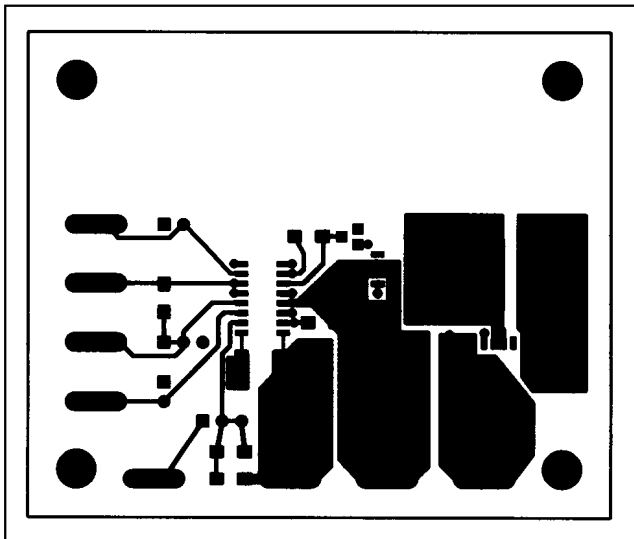

Figure 4. MAX797 EV Kit PC Board Layout—Component Side

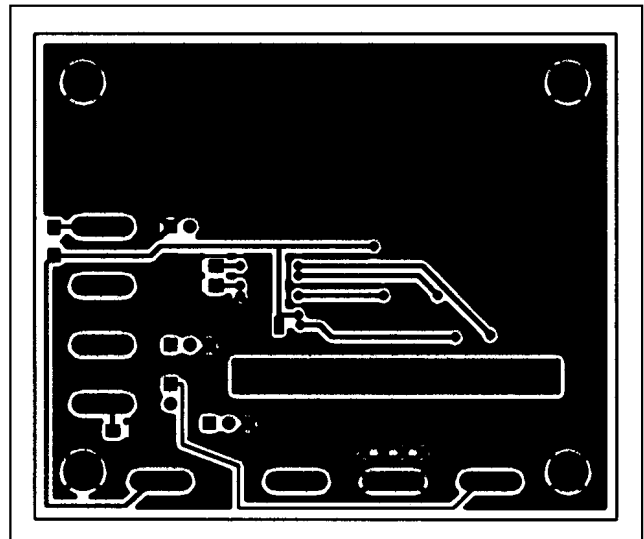

Figure 5. MAX797 EV Kit PC Board Layout—Solder Side

Maxim cannot assume responsibility for use of any circuitry other than circuitry entirely embodied in a Maxim product. No circuit patent licenses are implied. Maxim reserves the right to change the circuitry and specifications without notice at any time.

4 \_\_\_\_\_ Maxim Integrated Products, 120 San Gabriel Drive, Sunnyvale, CA 94086 408-737-7600

© 1997 Maxim Integrated Products

Printed USA

MAXIM is a registered trademark of Maxim Integrated Products.