

MAXIM

MAX8720 Evaluation Kit

Evaluates: MAX8720

General Description

The MAX8720 evaluation kit (EV kit) demonstrates the high-power, dynamically adjustable notebook CPU applications circuit. This DC-DC converter steps down high-voltage batteries and/or AC adapters, generating a precision, low-voltage CPU core VCC rail.

The MAX8720 EV kit provides a digitally adjustable 0.275V to 1.85V output voltage from a 7V to 24V battery input range. It delivers up to 15A output current. The EV kit operates at 300kHz switching frequency and has superior line- and load-transient response.

The MAX8720 has independent four-level logic inputs for setting the suspend voltage (S0-S1). Precision slew-rate control provides just-in-time arrival at the new DAC setting, minimizing surge currents to and from the battery.

This EV kit is a fully assembled and tested circuit board.

Features

- ◆ High Speed, Accuracy, and Efficiency
- ◆ Fast-Response Quick-PWM™ Architecture
- ◆ 7V to 24V Input Voltage Range
- ◆ 0.275V to 1.85V Output Voltage Adjust Range (6-Bit DAC)
- ◆ 15A Load-Current Capability
- ◆ Precision-Adjustable Output Slew Control
- ◆ Remote Feedback and Ground Sense
- ◆ 300kHz Switching Frequency
- ◆ No Current-Sense Resistor
- ◆ PGOOD Blanking During Transition
- ◆ Overvoltage/Undervoltage Protection
- ◆ 28-Pin QSOP Package
- ◆ Low-Profile Components
- ◆ Fully Assembled and Tested

Ordering Information

PART	TEMP RANGE	IC PACKAGE
MAX8720EVKIT	0°C to +70°C	28 QSOP

Component List

DESIGNATION	QTY	DESCRIPTION
C1, C2	2	10µF ±20%, 25V X5R ceramic capacitors (1210) TDK C3225X7R1E106M AVX 12103D106M Taiyo Yuden TMK325BJ106MM
C3	0	Not installed, 1000µF, 50V aluminum electrolytic capacitor (12.5mm x 25mm) Sanyo 50MV1000AX
C4, C10, C18	3	1000pF ±10%, 50V C0G ceramic capacitors (0603) TDK 1608X7R1H102K or Murata GRM188R71H102K or Equivalent
C5, C6, C7	3	470µF, 2.5V, 9mΩ low-ESR polymer capacitors (D case) Sanyo 2R5TPE470M9

Quick-PWM is a trademark of Maxim Integrated Products, Inc.

DESIGNATION	QTY	DESCRIPTION
C8	1	10µF ±20%, 6.3V X5R ceramic capacitor (0805) TDK C2012X5R0J106M or Taiyo Yuden AMK212BJ106MG
C9	1	0.1µF ±10%, 25V X7R ceramic capacitor (0603) Murata GRM188R71E104K or TDK C1608X7R1E104K
C11, C15	2	1µF ±20%, 10V X5R ceramic capacitors (0805) Taiyo Yuden LMK212BJ105KG or TDK C2012X5R1A105M
C12	1	0.22µF ±10%, 25V X5R ceramic capacitor (0805) Murata GRM219R71E224K Taiyo Yuden EMK212BJ224KG TDK C2012X7R1H224K



MAX8720 Evaluation Kit

Evaluates: MAX8720

Component List (continued)

DESIGNATION	QTY	DESCRIPTION
C13	1	4700pF ±10%, 50V X7R ceramic capacitor (0603) Murata GRM188R71H472K or equivalent
C14	1	47pF ±5%, 50V C0G ceramic capacitor (0603) Murata GRM1885C1H470J or equivalent
D1	1	3A, 30V Schottky diode Nihon EC31QS03L
D2	1	100mA Schottky diode Central Semiconductor CMPSH-3
JU1, JU2, JU3	3	4-pin headers
JU4, JU5, JU6	3	3-pin headers
JUA0–JUA5	6	2-pin headers
L1	1	0.8μH, 20A, 4.9mΩ power inductor Sumida CDEP104-0R8MC-50 (10mm x 10mm x 4.5mm)

DESIGNATION	QTY	DESCRIPTION
N1	1	n-channel MOSFET (SO-8) International Rectifier IRF7821 or Vishay/Siliconix Si7390DP (PowerPAK)
N2, N3	2	n-channel MOSFETs (SO-8) International Rectifier IRF7832 or Vishay/Siliconix Si7356DP (PowerPAK)
R1	1	10Ω ±5% resistor (0603)
R2, R3, R11	3	100Ω ±5% resistors (0603)
R4, R22–R27	7	100kΩ ±5% resistors (0603)
R5, R6, R8	0	Not installed (0603)
R7	0	Not installed (short PC trace) (0603)
R14, R18	2	100kΩ ±1% resistors (0603)
R19	1	32.4kΩ ±1% resistor (0603)
U1	1	MAX8720EEI (28-pin QSOP)
None	4	Rubber bumpers
None	11	Shunts
None	1	MAX8720 PC board

Component Suppliers

SUPPLIER	PHONE	FAX	WEBSITE
Central Semiconductor	516-435-1110	516-435-1824	www.centralsemi.com
International Rectifier	310-322-3331	310-322-3332	www.irf.com
Murata	770-436-1300	770-436-3636	www.murata.com
Nihon	847-843-7500	847-843-2798	www.niec.co.jp
Panasonic	714-373-7939	714-373-7183	www.panasonic.com
Sanyo	619-661-6835	619-661-1055	www.sanyovideo.com
Sumida	708-956-0666	708-956-0702	www.sumida.com
Taiyo Yuden	800-348-2496	847-925-0899	www.t-yuden.com
TDK	847-390-4373	847-390-4428	www.component.tdk.com
TOKO	408-432-8281	408-943-9790	www.tokoam.com
Vishay/Siliconix	408-970-5627	408-567-8942	www.vishay.com/mosfets

Note: Indicate that you are using the MAX8720 when contacting these manufacturers.

MAX8720 Evaluation Kit

Recommended Equipment

- 7V to 24V power supply, battery, or notebook AC adapter
- DC bias power supply, 5V at 100mA
- Dummy load capable of sinking 15A
- Digital multimeter (DMM)
- 100MHz dual-trace oscilloscope

Quick Start

- 1) Ensure that the circuit is connected correctly to the supplies and dummy load prior to applying any power.
- 2) Verify that the shunts are across:
 - JUA0, JUA3, JUA5
 - JU1 pins 1 and 3 (S0 = REF), JU2 pins 1 and 3 (S1 = REF), JU4 pins 2 and 3 (SUS = low)
 - JU5 pins 1 and 2 ($\overline{\text{SHDN}}$ high), JU6 pins 1 and 2 (SKIP high, forced PWM)
- 3) Turn on battery power prior to +5V bias power; otherwise, the output UVLO timer times out and the FAULT latch is set, disabling the regulator until +5V power is cycled or shutdown is toggled.
- 4) Verify that $V_{\text{OUT}} = 1.30\text{V}$. Observe the output with the DMM and/or oscilloscope. Look at the LX switching-node and MOSFET gate-drive signals while varying the load current.

Detailed Description

This 15A buck-regulator design is optimized for a 300kHz frequency and output voltage settings around 1.30V.

The output voltage can be digitally set from 0.275V to 1.85V from the VID0–VID5 pins (Table 1). At $V_{\text{OUT}} = 1.30\text{V}$ and $V_{\text{IN}} = 12\text{V}$, the inductor ripple is approximately 30% (LIR = 0.30).

Setting the Output Voltage

The MAX8720 uses a multiplexer that selects from two different inputs—the VID DAC inputs or the suspend-mode S0–S1 inputs (JU1, JU2). On startup, the MAX8720 slews the target voltage from ground to either the decoded D0–D5 (SUS, JU4 = low) voltage or the S0–S1 voltage (SUS, JU4 = high). The output voltage can be digitally set from 0.275V to 1.85V (Table 1) from the D0–D5 pins (JUA0–JUA5) and from 0.275V to 0.650V (Table 2) from S0–S1 pins (JU1, JU2). There are three different ways of setting the output voltage:

- 1) **Drive the external VID0–VID5 inputs (no jumpers installed).** The output voltage can be set by driving the VID0–VID5 with open-drain drivers (pullup resistors are included on the board) or 3V/5V CMOS output logic levels (SUS, JU4 = low).
- 2) **Install jumpers JUA0–JUA5.** The output voltage can be set by installing jumpers JUA0–JUA5. When jumpers JUA0–JUA5 are not installed, D0–D5 inputs are at logic 1 (connected to VCC). When jumpers JUA0–JUA5 are installed, D0–D5 inputs are at logic 0 (connected to GND). The output voltage can be changed during operation by installing and removing jumpers JUA0–JUA5. When shipped, the EV kit is configured for operation with jumpers JUA0–JUA5 set for 1.30V output (Table 1).
- 3) **Install jumpers JU1–JU2 (suspend mode, SUS = high).** When shipped, the EV kit is configured for operation in the suspend mode with jumpers JU1 and JU2 set for 0.525V output (Table 2). In the suspend mode, the output voltage can be changed during operation by installing and removing jumpers JU1 and JU2. Refer to the MAX8720 data sheet for more information.

MAX8720 Evaluation Kit

Evaluates: MAX8720

Jumper Settings

Table 1. Jumper Functions: JUA0–JUA5 (Output Voltage Adjustment Settings)

D5 JUA5	D4 JUA4	D3 JUA3	D2 JUA2	D1 JUA1	D0 JUA0	V _{OUT} (V)	D5 JUA5	D4 JUA4	D3 JUA3	D2 JUA2	D1 JUA1	D0 JUA0	V _{OUT} (V)
0	0	0	0	0	0	1.850	1	0	0	0	0	0	1.050
0	0	0	0	0	1	1.825	1	0	0	0	0	1	1.025
0	0	0	0	1	0	1.800	1	0	0	0	1	0	1.000
0	0	0	0	1	1	1.775	1	0	0	0	1	1	0.975
0	0	0	1	0	0	1.750	1	0	0	1	0	0	0.950
0	0	0	1	0	1	1.725	1	0	0	1	0	1	0.925
0	0	0	1	1	0	1.700	1	0	0	1	1	0	0.900
0	0	0	1	1	1	1.675	1	0	0	1	1	1	0.875
0	0	1	0	0	0	1.650	1	0	1	0	0	0	0.850
0	0	1	0	0	1	1.625	1	0	1	0	0	1	0.825
0	0	1	0	1	0	1.600	1	0	1	0	1	0	0.800
0	0	1	0	1	1	1.575	1	0	1	0	1	1	0.775
0	0	1	1	0	0	1.550	1	0	1	1	0	0	0.750
0	0	1	1	0	1	1.525	1	0	1	1	0	1	0.725
0	0	1	1	1	0	1.500	1	0	1	1	1	0	0.700
0	0	1	1	1	1	1.475	1	0	1	1	1	1	0.675
0	1	0	0	0	0	1.450	1	1	0	0	0	0	0.650
0	1	0	0	0	1	1.425	1	1	0	0	0	1	0.625
0	1	0	0	1	0	1.400	1	1	0	0	1	0	0.600
0	1	0	0	1	1	1.375	1	1	0	0	1	1	0.575
0	1	0	1	0	0	1.350	1	1	0	1	0	0	0.550
0	1	0	1	0	1	1.325	1	1	0	1	0	1	0.525
0	1	0	1	1	0	1.300	1	1	0	1	1	0	0.500
0	1	0	1	1	1	1.275	1	1	0	1	1	1	0.475
0	1	1	0	0	0	1.250	1	1	1	0	0	0	0.450
0	1	1	0	0	1	1.225	1	1	1	0	0	1	0.425
0	1	1	0	1	0	1.200	1	1	1	0	1	0	0.400
0	1	1	0	1	1	1.175	1	1	1	0	1	1	0.375
0	1	1	1	0	0	1.150	1	1	1	1	0	0	0.350
0	1	1	1	0	1	1.125	1	1	1	1	0	1	0.325
0	1	1	1	1	0	1.100	1	1	1	1	1	0	0.300
0	1	1	1	1	1	1.075	1	1	1	1	1	1	0.275

MAX8720 Evaluation Kit

Evaluates: MAX8720

Table 2. Jumper Functions: JU1 and JU2 (Output Voltage Adjustment Settings, Suspend Mode)

SHUNT LOCATION JU2	SHUNT LOCATION JU1	S1 PIN	S0 PIN	V _{OUT} (V)
1, 2	1, 2	GND	GND	0.650
1, 2	1, 3	GND	REF	0.625
1, 2	Not installed	GND	Open	0.600
1, 2	1, 4	GND	VCC	0.575
1, 3	1, 2	REF	GND	0.550
1, 3	1, 3	REF	REF	0.525
1, 3	Not installed	REF	Open	0.500
1, 3	1, 4	REF	VCC	0.475
Not installed	1, 2	Open	GND	0.450
Not installed	1, 3	Open	REF	0.425
Not installed	Not installed	Open	Open	0.400
Not installed	1, 4	Open	VCC	0.375
1, 4	1, 2	VCC	GND	0.350
1, 4	1, 3	VCC	REF	0.325
1, 4	Not installed	VCC	Open	0.300
1, 4	1, 4	VCC	VCC	0.275

Table 3. Jumper Functions: JU3 (Switching-Frequency Selection)

JU3	TON PIN	FREQUENCY (kHz)
1 and 2	Connected to GND.	1000
1 and 3	Connected to VCC.	200
1 and 4	Connected to REF.	550
Not installed (default)	Floating.	300 (as shipped)

Note: Do not change the operating frequency without first recalculating component values. The frequency has a significant effect on preferred inductor value, peak current-limit level, MOSFET heating, PFM/PWM switchover point, output noise, efficiency, and other critical parameters.

MAX8720 Evaluation Kit

Evaluates: MAX8720

Table 4. Jumper Functions: JU4 (Suspend-Mode Control Input)

JU4	SUS PIN	V _{OUT}
1 and 2	Connected to VCC.	The suspend mode VID code, as programmed by S0 and S1, is delivered to the DAC.
1 and 3	Connected to GND.	The suspend-mode multiplexer is not used.
Not installed	SUS must be driven by an external signal connected to the DPRSLPVR pad.	V _{OUT} depends on the external DPRSLPVR level.

Table 5. Jumper Functions: JU5 (Shutdown Mode)

JU5	$\overline{\text{SHDN}}$ PIN	MAX8720 OUTPUT
1 and 2	Connected to VCC.	Output enabled.
2 and 3	Connected to GND.	Shutdown mode, V _{OUT} = 0V.
Not installed	$\overline{\text{SHDN}}$ must be driven by an external signal connected to SHDN pad.	V _{OUT} depends on the external SHDN level.

Table 6. Jumper Functions: JU6 (Pulse-Skipping Control Input)

JU6	$\overline{\text{SKIP}}$ PIN	OPERATIONAL MODE
1 and 2	Connected to VCC.	Low-noise mode, forced-PWM operation.
2 and 3	Connected to GND.	Normal operation, allows automatic PWM/PFM switchover for pulse-skipping at light-load, resulting in highest efficiency.

MAX8720 Evaluation Kit

Evaluates: MAX8720

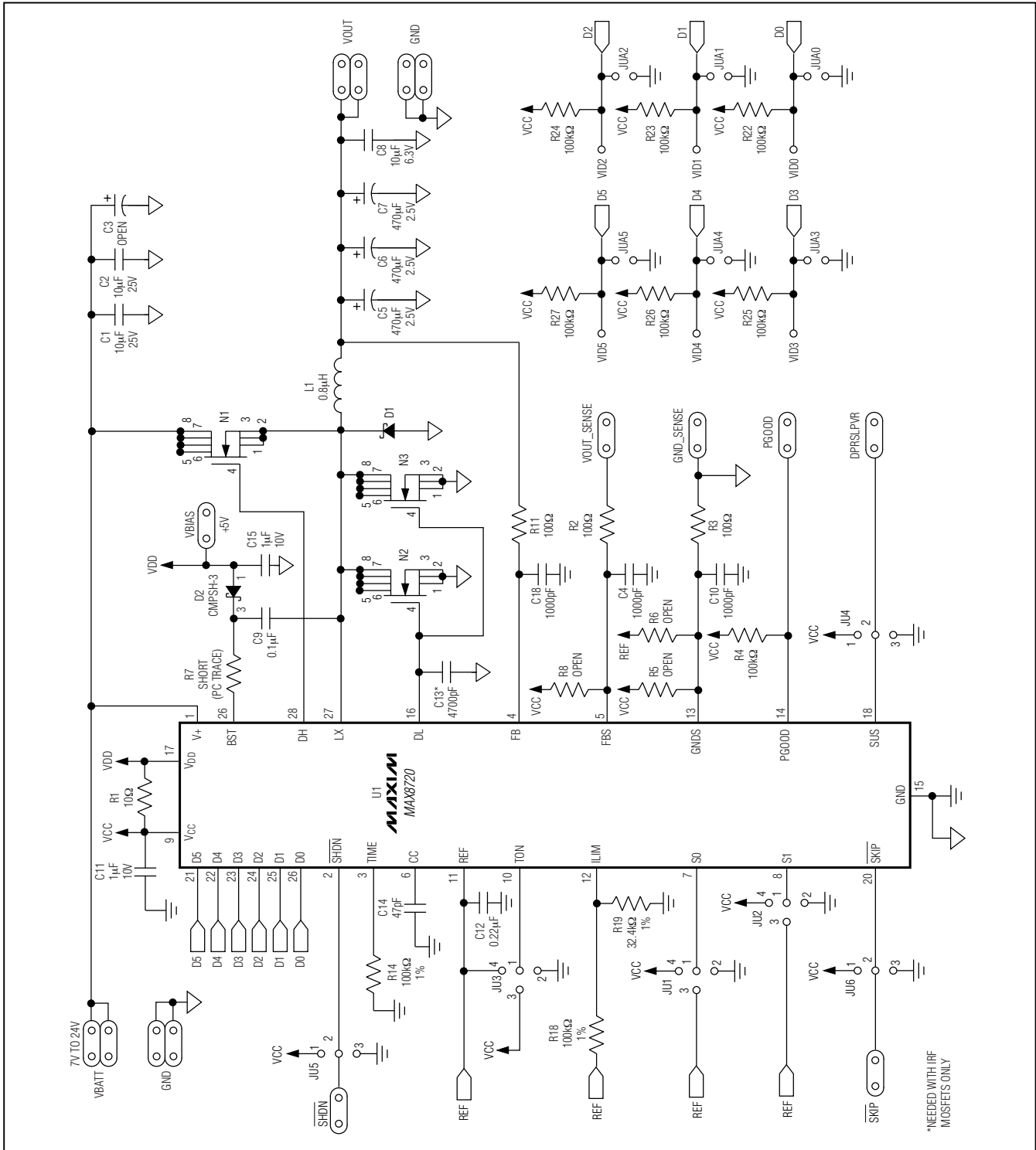

Figure 1. MAX8720 EV Kit Schematic

MAX8720 Evaluation Kit

Evaluates: MAX8720

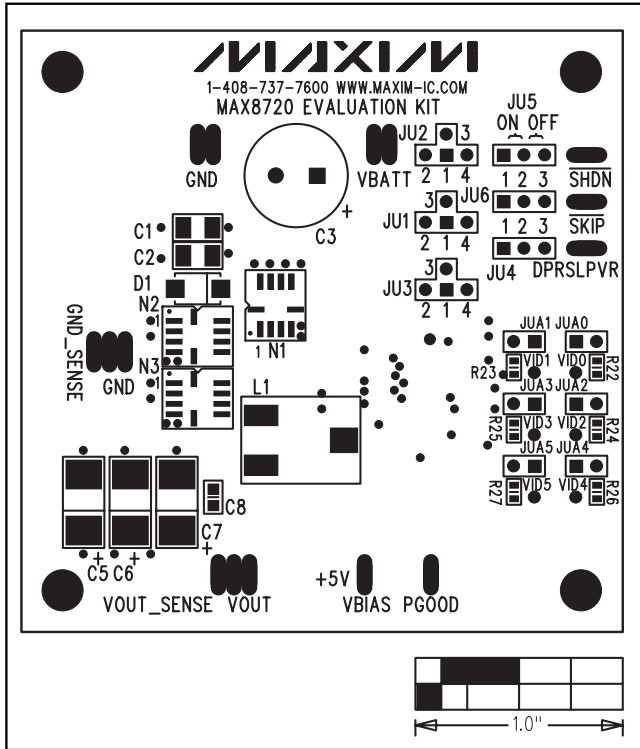

Figure 2. MAX8720 EV Kit Component Placement Guide—Component Side

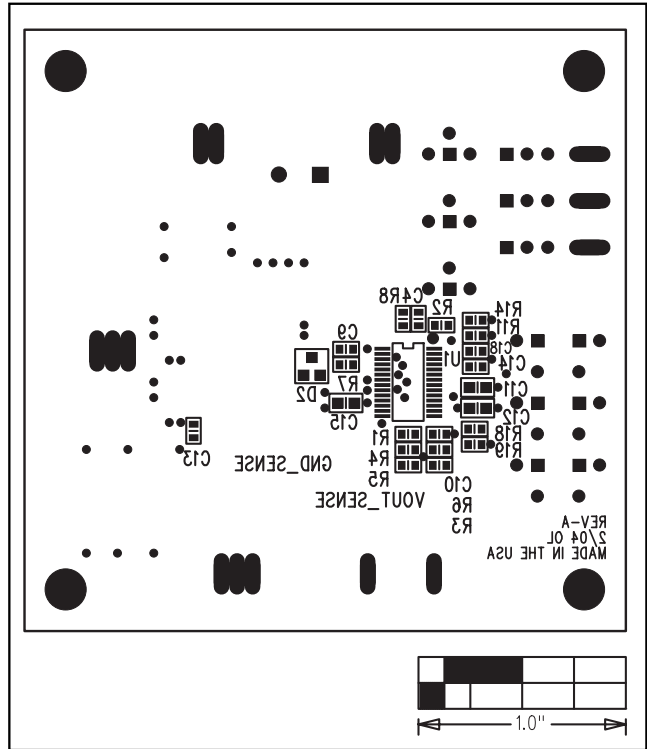

Figure 3. MAX8720 EV Kit Component Placement Guide—Solder Side

MAX8720 Evaluation Kit

Evaluates: MAX8720

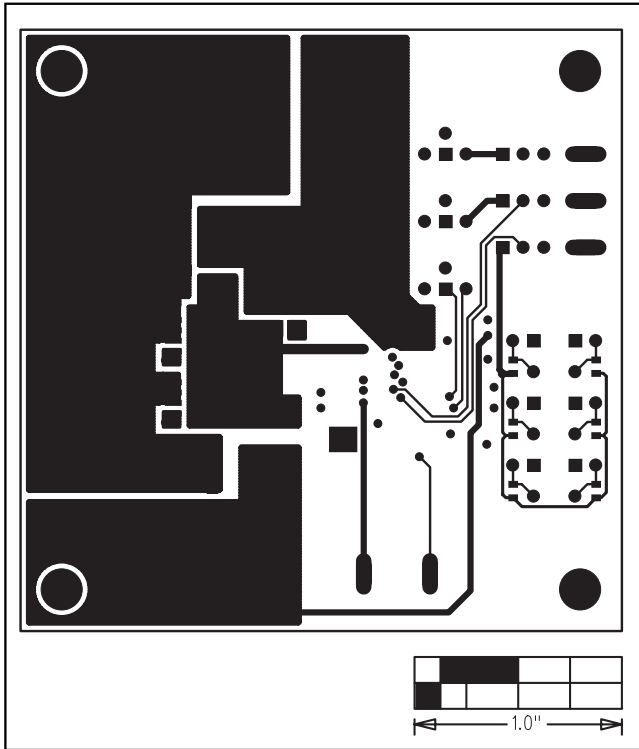

Figure 4. MAX8720 EV Kit PC Board Layout—Component Side

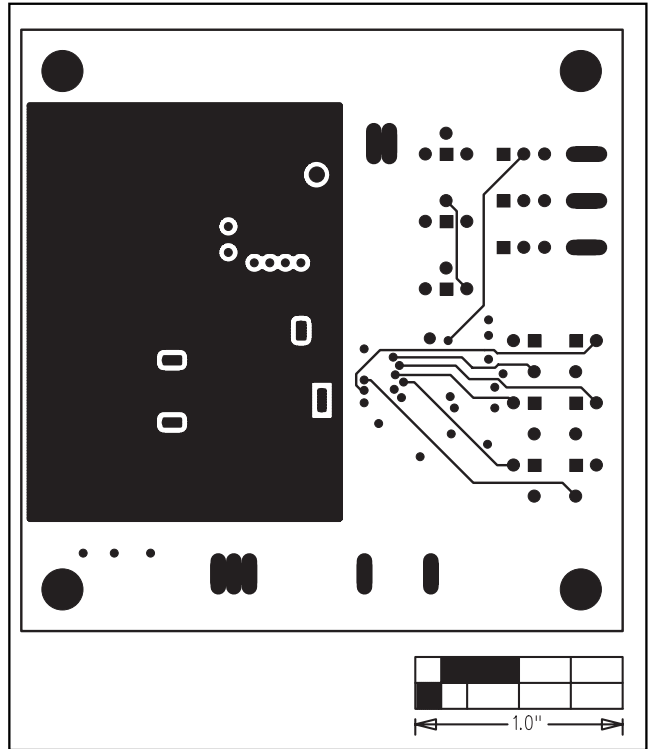

Figure 5. MAX8720 EV Kit PC Board Layout—Internal GND/Signal Layer

MAX8720 Evaluation Kit

Evaluates: MAX8720

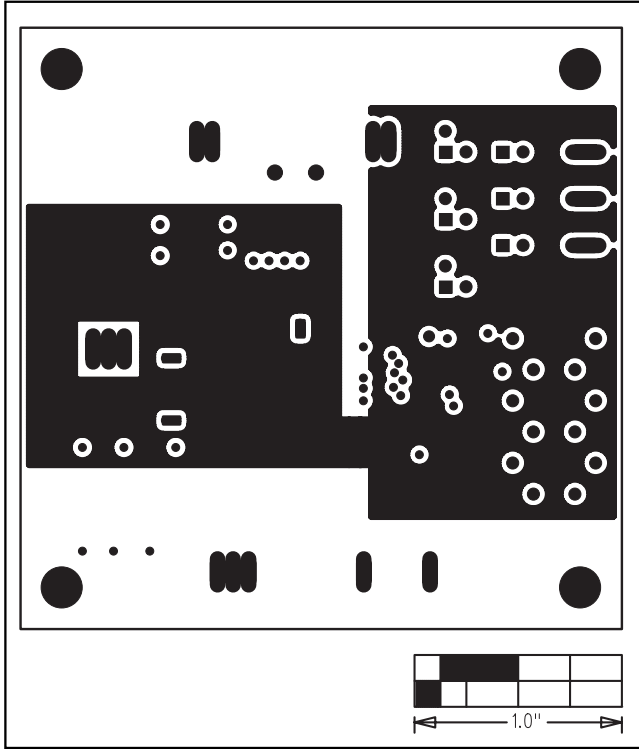

Figure 6. MAX8720 EV Kit PC Board Layout—Internal GND Layer

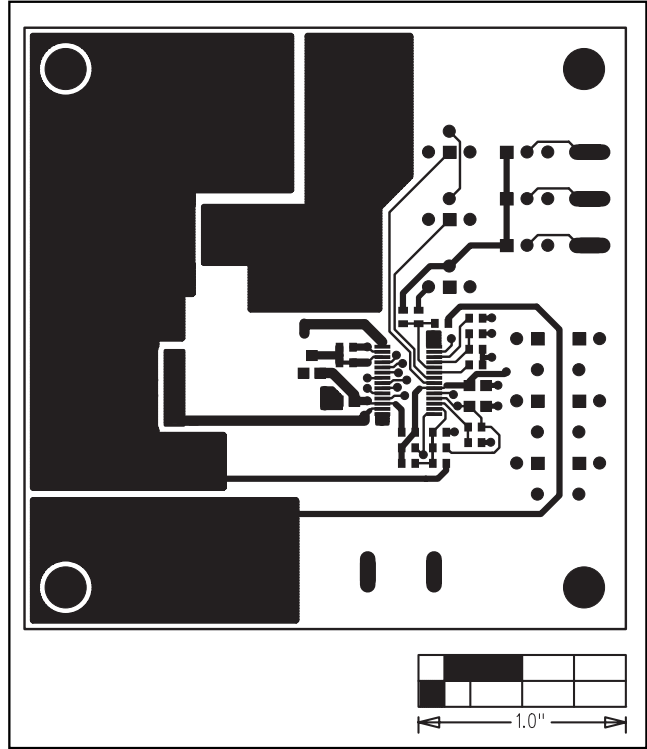

Figure 7. MAX8720 EV Kit PC Board Layout—Solder Side

Maxim cannot assume responsibility for use of any circuitry other than circuitry entirely embodied in a Maxim product. No circuit patent licenses are implied. Maxim reserves the right to change the circuitry and specifications without notice at any time.

10 _____ **Maxim Integrated Products, 120 San Gabriel Drive, Sunnyvale, CA 94086 408-737-7600**