



MAX8737 Evaluation Kit

Evaluates: MAX8737

General Description

The MAX8737 evaluation kit (EV kit) is a fully assembled and tested surface-mount circuit board that evaluates the MAX8737 dual low-voltage linear regulator controller IC and two external MOSFETs to form a dual linear regulator circuit. The MAX8737 EV kit outputs are configured to provide 1.5V and 1.05V regulated output voltages with peak loads up to 2A and 3A, respectively.

The MAX8737 EV kit demonstrates the MAX8737 fold-back current-limit capabilities. The MAX8737 EV kit provides PC board pads to evaluate the PGOOD feature of the MAX8737 IC. The PGOOD signals can be used as system-reset signals in various applications. The MAX8737 EV kit also demonstrates the output-enable feature of the MAX8737 IC. The MAX8737 low-voltage linear regulator controller is suitable for CPU power-supply applications in notebook, desktop, and other high-current applications (such as automotive).

Features

- ◆ Dual-Regulated Output Voltages
1.5V at Up to 2A (Peak)
1.05V at Up to 3A (Peak)
- ◆ Configurable Output Voltages
- ◆ Configurable Foldback Current Limit
- ◆ Thermal Protection
- ◆ Output Undervoltage Lockout Protection
- ◆ Independent PGOOD Signal for Each Output
- ◆ Tiny 4mm x 4mm, 16-Pin Thin QFN Package
- ◆ Low-Profile, Surface-Mount Components
- ◆ Fully Assembled and Tested

Ordering Information

PART	TEMP RANGE	IC PACKAGE
MAX8737EVKIT	0°C to +70°C*	16 Thin QFN-EP**

*PC board rating only.

**EP = Exposed pad.

Component List

DESIGNATION	QTY	DESCRIPTION
C1	0	Not installed, capacitor (0805)
C2, C11	2	1 μ F \pm 10%, 10V X7R ceramic capacitors (0603) TDK C1608X7R1A105K
C3, C6, C7	3	10 μ F \pm 20%, 4V X5R ceramic capacitors (0603) TDK C1608X5R0G106M
C4, C8	2	220 μ F \pm 20%, 6.3V POSCAPs (D4) Sanyo 6TPD220M
C5	1	0.1 μ F \pm 10%, 10V X5R ceramic capacitor (0402) TDK C1005X5R1A104K
C9	1	0.22 μ F \pm 10%, 6.3V X5R ceramic capacitor (0402) TDK C1005X5R0J224K
C10	1	22 μ F \pm 20%, 6.3V X5R ceramic capacitor (0805) TDK C2012X5R0J226M
JU1, JU2	2	3-pin headers
N1	1	30V, 6.7A dual n-channel MOSFET (8-pin SO) Vishay Si4922DY

DESIGNATION	QTY	DESCRIPTION
R1, R4	2	0.020 Ω \pm 1% resistors (1206) IRC LRCLR120601R020F
R2, R5	2	10 Ω \pm 1% resistors (0603)
R3	1	374 Ω \pm 1% resistor (0603)
R6	1	162 Ω \pm 1% resistor (0603)
R7	1	27 Ω \pm 5% resistor (0603)
R8	1	33 Ω \pm 5% resistor (0603)
R9	1	102k Ω \pm 1% resistor (0603)
R10	1	90.9k Ω \pm 1% resistor (0603)
R11, R12	2	100k Ω \pm 5% resistors (0603)
R13	1	100k Ω \pm 1% resistor (0603)
R14	1	33.2k Ω \pm 1% resistor (0603)
R15, R16	0	Not installed, resistors (0603)
TP1, TP2	2	Test points (red)
U1	1	MAX8737ETE (16-pin thin QFN with EP 4mm x 4mm)
—	2	Shunts (JU1, JU2)
—	1	MAX8737 EV kit board

MAX8737 Evaluation Kit

Component Suppliers

SUPPLIER	PHONE	FAX	WEBSITE
IRC	361-992-7900	361-992-3377	www.irctt.com
Sanyo Electronic Device	619-661-6835	619-661-1055	www.sanyodevice.com
TDK	972-580-7777	972-550-1309	www.components.tdk.com
Vishay	203-268-6261	203-452-5670	www.vishay.com

Note: Indicate that you are using the MAX8737 when contacting these component suppliers.

Quick Start

Recommended Equipment

- 5V power supply (PS1) capable of handling up to 100mA
- 2V \pm 1% power supply (PS2) capable of handling up to 5mA
- 1.25V power supply (PS3) capable of handling up to 5A
- 1.8V power supply (PS4) capable of handling up to 5A
- Two digital voltmeters (DVM1 and DVM2)

The MAX8737 EV kit is fully assembled and tested. Follow these steps to verify board operation. **Do not turn on the power supplies until all connections are completed:**

- 1) Verify that shunts are installed across pins 1 and 2 of jumpers JU1 and JU2.
- 2) Connect DVM1 across the VOUT1 and GND pads located near capacitor C4.
- 3) Connect DVM2 across the VOUT2 and GND pads located near capacitor C8.
- 4) Connect the PS1 power supply across the VCC and GND pads located near capacitor C1.
- 5) Connect the PS2 power supply across the VREF and GND pads located near capacitor C11.
- 6) Connect the PS3 power supply across the VIN2 and GND pads located near capacitor C8.
- 7) Connect the PS4 power supply across the VIN1 and GND pads located near capacitor C4.
- 8) Turn on the PS1 and PS2 power supplies.
- 9) Turn on the PS3 and PS4 power supplies.
- 10) Verify the DVM1 voltmeter measures 1.50V.
- 11) Verify the DVM2 voltmeter measures 1.05V.

Detailed Description

The MAX8737 EV kit circuit uses a MAX8737 controller to implement two low-voltage, low-dropout linear regulators (LDOs). The LDO inputs, V_{IN1} and V_{IN2} , are configured to operate from 200mV to 500mV above their respective output voltages. The MAX8737 EV kit outputs, V_{OUT1} and V_{OUT2} , are configured to provide 1.5V at up to 2A (peak) and 1.05V at up to 3A (peak), respectively.

The MAX8737 EV kit features a dual-MOSFET package to achieve lower overall system cost. **However, the dual MOSFET limits the power dissipation to 1.1W per output. This restriction limits the RMS current to 1.5A_{RMS} for the 1.5V output (from a 1.8V input) and to 2A_{RMS} for the 1.05V output (from a 1.5V input).**

The EV kit uses a separate 5V biasing power supply to power the MAX8737 controller and an external 2V reference to generate the feedback threshold voltages.

The EV kit provides jumper-selectable enable inputs for the two LDO outputs. The EV kit also provides PC board pads to access the PGOOD1 and PGOOD2 signals that can be used as system reset signals during power-up in various applications. The EV kit demonstrates the configurable foldback current-limit feature of the MAX8737.

Output Voltages (V_{OUT1} and V_{OUT2})

The MAX8737 EV kit outputs, V_{OUT1} and V_{OUT2} , are configured to provide 1.5V at up to 2A (peak) and 1.05V at up to 3A (peak), respectively. The V_{OUT1} output regulation voltage is set by resistors R13 and R14. The V_{OUT2} output regulation voltage is set by resistors R9 and R10. The output voltages, V_{OUT1} and V_{OUT2} , may be reconfigured in the 0.5V to 2.5V range. Use the following equations to reconfigure the output voltages to a desired value:

$$R14 = R13 \times \left[\frac{V_{REF}}{V_{OUT1}} - 1 \right]$$

MAX8737 Evaluation Kit

Evaluates: MAX8737

where V_{REF} is the external reference voltage. Resistor R13 is 100k Ω :

$$R10 = R9 \times \left[\frac{V_{REF}}{V_{OUT2}} - 1 \right]$$

where V_{REF} is the external reference voltage. Resistor R9 is 102k Ω .

Depending upon the desired output voltages, some of the MAX8737 EV kit components may require replacement. Refer to the *REFIN Input* section in the MAX8737 IC data sheet for more information on configuring the MAX8737 EV kit output voltages.

Output Current Limits

The MAX8737 features an output current limit to prevent MOSFET failure. The MAX8737 EV kit V_{OUT1} and V_{OUT2} output peak current limits are configured to 2A and 3A by current-sense resistors R1 and R4, respectively. To select new resistor values for R1 and R4, refer to the *Current Limit* section in the MAX8737 IC data sheet. The MAX8737 EV kit PC board traces are 2oz copper and can handle up to 5A of load current. Changing the current limits may require capacitors C6 and/or C10 to be replaced. To select new values for these components, refer to the *Design Procedure* section in the MAX8737 IC data sheet.

PGOOD Outputs (PGOOD1 and PGOOD2)

The MAX8737 EV kit provides PC board pads to access the power-good output signals of the MAX8737. The PGOOD1 and PGOOD2 output signals can be used as system reset signals during power-up. The

open-drain PGOOD1 and PGOOD2 signals are pulled high when their respective output voltages (V_{OUT1} and V_{OUT2}) rise above 92% (typ) of the nominal regulated voltage. The PGOOD1 and PGOOD2 outputs are pulled low when their respective output voltages (V_{OUT1} and V_{OUT2}) drop below 88% (typ) of nominal regulated voltage.

Output Enables (EN1 and EN2)

The MAX8737 EV kit features jumpers JU1 and JU2 to independently enable outputs V_{OUT2} and V_{OUT1} , respectively. See Table 1 and Table 2 for jumper JU1 and JU2 functions.

Table 1. Jumper JU1 Function

SHUNT LOCATION	EN2 PIN CONNECTION	EV KIT FUNCTION
1 and 2	Connected to V_{CC}	VOUT2 is enabled
2 and 3	Connected to GND	VOUT2 is disabled

Table 2. Jumper JU2 Function

SHUNT LOCATION	EN1 PIN CONNECTION	EV KIT FUNCTION
1 and 2	Connected to V_{CC}	VOUT1 is enabled
2 and 3	Connected to GND	VOUT1 is disabled

MAX8737 Evaluation Kit

Evaluates: MAX8737

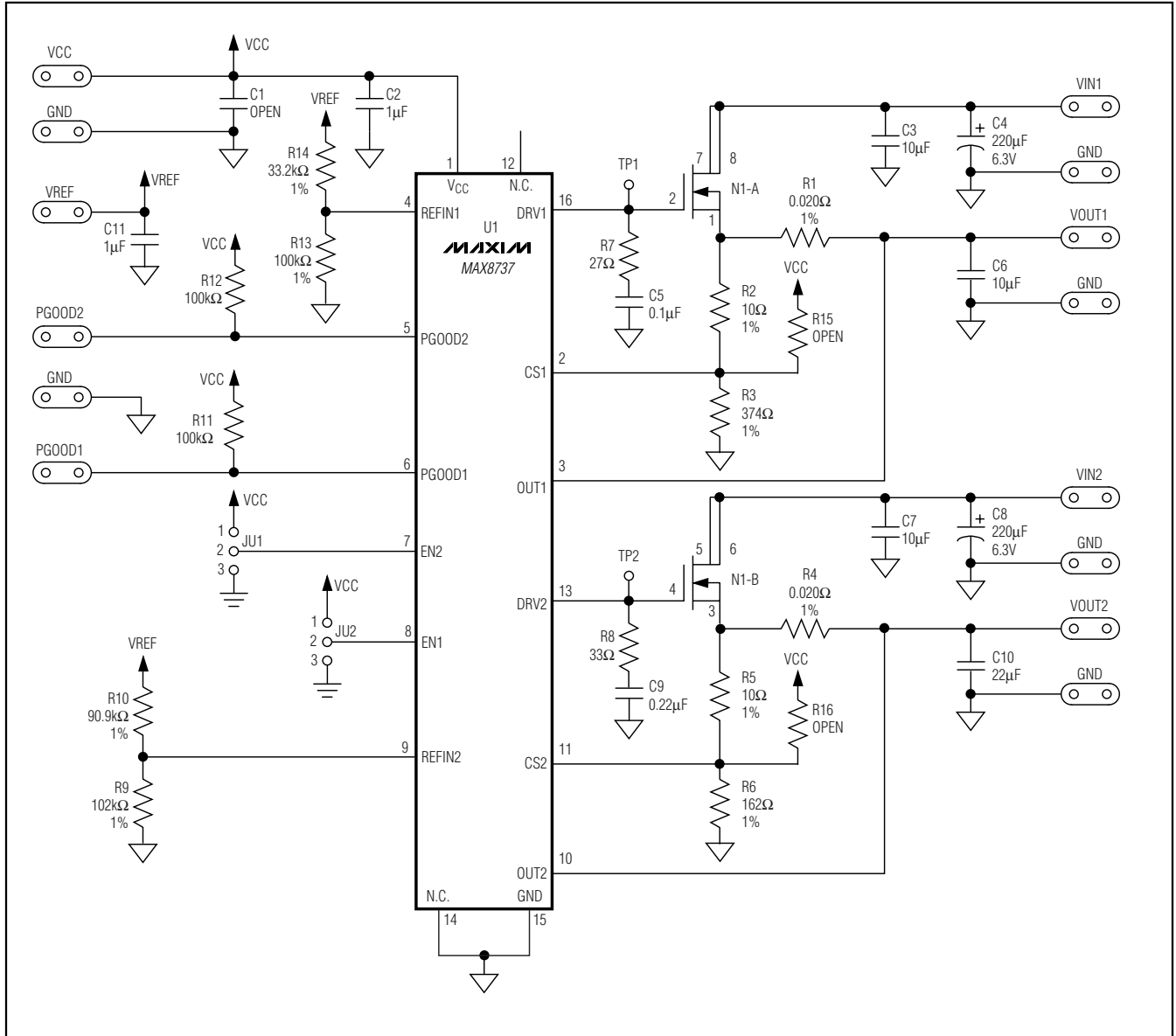

Figure 1. MAX8737 EV Kit Schematic

MAX8737 Evaluation Kit

Evaluates: MAX8737

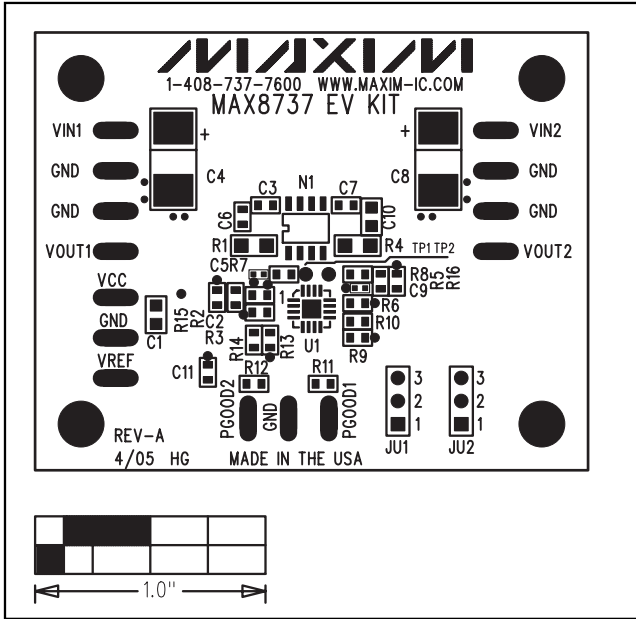

Figure 2. MAX8737 EV Kit Component Placement Guide—Component Side

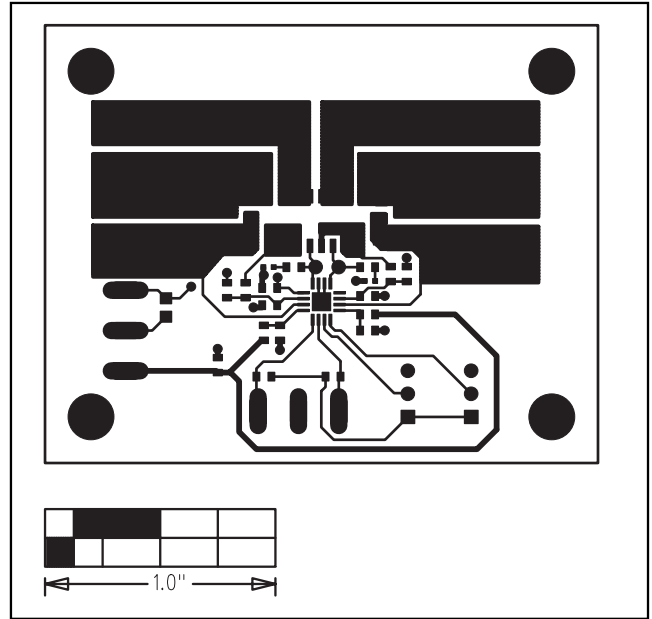

Figure 3. MAX8737 EV Kit PC Board Layout—Component Side

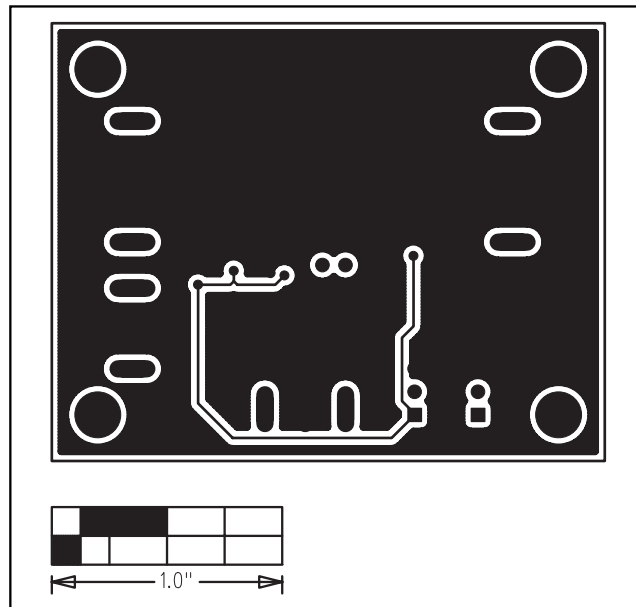

Figure 4. MAX8737 EV Kit PC Board Layout—Solder Side

Maxim cannot assume responsibility for use of any circuitry other than circuitry entirely embodied in a Maxim product. No circuit patent licenses are implied. Maxim reserves the right to change the circuitry and specifications without notice at any time.

Maxim Integrated Products, 120 San Gabriel Drive, Sunnyvale, CA 94086 408-737-7600 _____ 5