

# 68HC908AT32

## Data Sheet

**M68HC08**  
**Microcontrollers**

**Rev. 2.1**  
**HC908AT32GRS/D**  
**July 29, 2005**

[freescale.com](http://freescale.com)





## List of Sections

Section 1. General Description . . . . .	41
Section 2. Memory Map . . . . .	59
Section 3. Random-Access Memory (RAM) . . . . .	75
Section 4. FLASH Memory . . . . .	77
Section 5. Electrically Erasable Programmable ROM (EEPROM) . . . . .	85
Section 6. Central Processor Unit (CPU) . . . . .	97
Section 7. System Integration Module (SIM) . . . . .	115
Section 8. Clock Generator Module (CGM) . . . . .	139
Section 9. Configuration Register (CONFIG-1) . . . . .	167
Section 10. Configuration Register (CONFIG-2) . . . . .	171
Section 11. Break Module (BRK) . . . . .	173
Section 12. Monitor ROM (MON) . . . . .	181
Section 13. Computer Operating Properly Module (COP) . . . . .	191
Section 14. Low-Voltage Inhibit (LVI) . . . . .	197
Section 15. External Interrupt (IRQ) . . . . .	203
Section 16. Serial Communications Interface Module (SCI) . . . . .	211
Section 17. Serial Peripheral Interface (SPI) . . . . .	253

## Controller Area Network (CAN) 64-Pin Quad Flat Pack

Section 18. Timer Interface (TIMA-4) . . . . .	289
Section 19. Timer Interface (TIMB) . . . . .	319
Section 20. Modulo Timer (TIM) . . . . .	345
Section 21. Analog-to-Digital Converter (ADC-8) . . .	355
Section 22. MC68HC08AZ32 Emulator Input/Output Ports . . . . .	367
Section 23. MSCAN Controller . . . . .	395
Section 24. Keyboard Interrupt Module (KBD) . . . . .	443
Section 25. Timer Interface (TIMA-6) . . . . .	451
Section 26. Analog-to-Digital Converter (ADC-15) . . . . .	483
Section 27. MC68HC08AS20 Emulator Input/Output Ports . . . . .	495
Section 28. Byte Data Link Controller-Digital (BDLC-D) . . . . .	517
Section 29. Electrical Specifications . . . . .	565
Section 30. Mechanical Data . . . . .	579
Section 31. Ordering Information . . . . .	583

## Table of Contents

### Section 1. General Description

1.1	Contents . . . . .	41
1.2	Introduction . . . . .	42
1.3	Features . . . . .	42
1.4	MCU Block Diagram . . . . .	45
1.5	Pin Assignments . . . . .	48
1.5.1	Power Supply Pins ( $V_{DD}$ and $V_{SS}$ ) . . . . .	50
1.5.2	Oscillator Pins (OSC1 and OSC2) . . . . .	51
1.5.3	External Reset Pin ( $\overline{RST}$ ) . . . . .	51
1.5.4	External Interrupt Pin ( $\overline{IRQ}$ ) . . . . .	51
1.5.5	Analog Power Supply Pin ( $V_{DDA}$ ) . . . . .	51
1.5.6	Analog Ground Pin ( $V_{SSA}$ ) . . . . .	51
1.5.7	External Filter Capacitor Pin (CGMXFC) . . . . .	52
1.5.8	Port A Input/Output (I/O) Pins (PTA7–PTA0) . . . . .	52
1.5.9	Port B I/O Pins (PTB7/ATD7–PTB0/ATD0) . . . . .	52
1.5.10	Port C I/O Pins (PTC5–PTC0) . . . . .	52
1.5.11	Port D I/O Pins (PTD7/ATD15–PTD0/ATD8) . . . . .	52
1.5.12	Port E I/O Pins (PTE7/SPSCK–PTE0/TxD) . . . . .	53
1.5.13	Port F I/O Pins (PTF6–PTF0/TACH2) . . . . .	53
1.5.14	Port G I/O Pins (PTG2/KBD2–PTG0/KBD0) . . . . .	53
1.5.15	Port H I/O Pins (PTH1/KBD4–PTH0/KBD3) . . . . .	54
1.5.16	CAN Transmit Pin (CANTx)/BDLC Transmit Pin (BDTx) . . . . .	54
1.5.17	CAN Receive Pin (CANRx)/BDLC Receive Pin (BDRx) . . . . .	54

**Section 2. Memory Map**

2.1 Contents . . . . .59  
 2.2 Introduction . . . . .59  
 2.3 I/O Section . . . . .63

**Section 3. Random-Access Memory (RAM)**

3.1 Contents . . . . .75  
 3.2 Introduction . . . . .75  
 3.3 Functional Description . . . . .75

**Section 4. FLASH Memory**

4.1 Contents . . . . .77  
 4.2 Introduction . . . . .77  
 4.3 Functional Description . . . . .77  
 4.4 FLASH Control Register . . . . .78  
 4.5 Charge Pump Frequency Control . . . . .80  
 4.6 FLASH Erase Operation . . . . .80  
 4.7 FLASH Program/Verify Operation . . . . .81  
 4.8 Block Protection . . . . .82  
 4.9 FLASH Block Protect Register . . . . .83

**Section 5. Electrically Erasable Programmable ROM (EEPROM)**

5.1 Contents . . . . .85  
 5.2 Introduction . . . . .85  
 5.3 Features . . . . .86  
 5.4 Functional Description . . . . .86  
 5.4.1 EEPROM Programming . . . . .86  
 5.4.2 EEPROM Erasing . . . . .88

5.4.3	EEPROM Block Protection . . . . .	90
5.4.4	EEPROM Redundant Mode . . . . .	90
5.4.5	MCU Configuration . . . . .	91
5.4.6	MC68HC908AT32 EEPROM Security . . . . .	91
5.4.7	EEPROM Control Register . . . . .	92
5.4.8	EEPROM Nonvolatile Register and EEPROM Array Configuration Register . . . . .	94
5.4.9	Low-Power Modes. . . . .	95
5.4.9.1	Wait Mode . . . . .	95
5.4.9.2	Stop Mode . . . . .	95

## Section 6. Central Processor Unit (CPU)

6.1	Contents . . . . .	97
6.2	Introduction. . . . .	97
6.3	Features . . . . .	98
6.4	CPU Registers . . . . .	98
6.4.1	Accumulator . . . . .	99
6.4.2	Index Register . . . . .	99
6.4.3	Stack Pointer. . . . .	100
6.4.4	Program Counter. . . . .	101
6.4.5	Condition Code Register . . . . .	102
6.5	Arithmetic/Logic Unit (ALU) . . . . .	104
6.6	Low-Power Modes . . . . .	104
6.6.1	Wait Mode . . . . .	104
6.6.2	Stop Mode. . . . .	104
6.7	CPU During Break Interrupts . . . . .	105
6.8	Instruction Set Summary . . . . .	106
6.9	Opcode Map . . . . .	113

## Section 7. System Integration Module (SIM)

7.1	Contents . . . . .	115
7.2	Introduction . . . . .	116
7.3	SIM Bus Clock Control and Generation . . . . .	119
7.3.1	Bus Timing . . . . .	119
7.3.2	Clock Startup from POR or LVI Reset. . . . .	119
7.3.3	Clocks in Stop Mode and Wait Mode . . . . .	120
7.4	Reset and System Initialization. . . . .	120
7.4.1	External Pin Reset. . . . .	121
7.4.2	Active Resets from Internal Sources. . . . .	122
7.4.2.1	Power-On Reset . . . . .	123
7.4.2.2	Computer Operating Properly (COP) Reset. . . . .	124
7.4.2.3	Illegal Opcode Reset . . . . .	124
7.4.2.4	Illegal Address Reset. . . . .	124
7.4.2.5	Low-Voltage Inhibit (LVI) Reset . . . . .	124
7.5	SIM Counter . . . . .	125
7.5.1	SIM Counter During Power-On Reset. . . . .	125
7.5.2	SIM Counter During Stop Mode Recovery . . . . .	125
7.5.3	SIM Counter and Reset States . . . . .	125
7.6	Program Exception Control. . . . .	126
7.6.1	Interrupts . . . . .	126
7.6.2	Reset. . . . .	130
7.6.3	Break Interrupts. . . . .	130
7.6.4	Status Flag Protection in Break Mode. . . . .	130
7.7	Low-Power Modes . . . . .	131
7.7.1	Wait Mode . . . . .	131
7.7.2	Stop Mode. . . . .	133
7.8	SIM Registers . . . . .	134
7.8.1	SIM Break Status Register . . . . .	134
7.8.2	SIM Reset Status Register . . . . .	136
7.8.3	SIM Break Flag Control Register. . . . .	137



## Section 8. Clock Generator Module (CGM)

8.1	Contents . . . . .	139
8.2	Introduction . . . . .	140
8.3	Features . . . . .	140
8.4	Functional Description . . . . .	141
8.4.1	Crystal Oscillator Circuit . . . . .	141
8.4.2	Phase-Locked Loop Circuit (PLL) . . . . .	144
8.4.2.1	Circuits . . . . .	144
8.4.2.2	Acquisition and Tracking Modes . . . . .	145
8.4.2.3	Manual and Automatic PLL Bandwidth Modes . . . . .	145
8.4.2.4	Programming the PLL . . . . .	147
8.4.2.5	Special Programming Exceptions . . . . .	149
8.4.3	Base Clock Selector Circuit. . . . .	149
8.4.4	CGM External Connections. . . . .	150
8.5	I/O Signals . . . . .	151
8.5.1	Crystal Amplifier Input Pin (OSC1) . . . . .	151
8.5.2	Crystal Amplifier Output Pin (OSC2). . . . .	151
8.5.3	External Filter Capacitor Pin (CGMXFC). . . . .	151
8.5.4	Analog Power Pin ( $V_{DDA}$ ) . . . . .	152
8.5.5	Oscillator Enable Signal (SIMOSCEN) . . . . .	152
8.5.6	Crystal Output Frequency Signal (CGMXCLK). . . . .	152
8.5.7	CGM Base Clock Output (CGMOUT) . . . . .	152
8.5.8	CGM CPU Interrupt (CGMINT) . . . . .	152
8.6	CGM Registers . . . . .	153
8.6.1	PLL Control Register . . . . .	153
8.6.2	PLL Bandwidth Control Register . . . . .	155
8.6.3	PLL Programming Register. . . . .	157
8.7	Interrupts . . . . .	159
8.8	Low-Power Modes . . . . .	159
8.8.1	Wait Mode . . . . .	159
8.8.2	Stop Mode. . . . .	160
8.9	CGM During Break Interrupts. . . . .	160

8.10	Acquisition/Lock Time Specifications	160
8.10.1	Acquisition/Lock Time Definitions	161
8.10.2	Parametric Influences on Reaction Time	162
8.10.3	Choosing a Filter Capacitor	163
8.10.4	Reaction Time Calculation	164

## Section 9. Configuration Register (CONFIG-1)

9.1	Contents	167
9.2	Introduction	167
9.3	Functional Description	168

## Section 10. Configuration Register (CONFIG-2)

10.1	Contents	171
10.2	Introduction	171
10.3	Functional Description	172

## Section 11. Break Module (BRK)

11.1	Contents	173
11.2	Introduction	173
11.3	Features	174
11.4	Functional Description	174
11.4.1	Flag Protection During Break Interrupts	176
11.4.2	CPU During Break Interrupts	176
11.4.3	TIM During Break Interrupts	176
11.4.4	COP During Break Interrupts	176
11.5	Low-Power Modes	177
11.5.1	Wait Mode	177
11.5.2	Stop Mode	177

11.6	Break Module Registers . . . . .	178
11.6.1	Break Status and Control Register . . . . .	178
11.6.2	Break Address Registers. . . . .	179

## Section 12. Monitor ROM (MON)

12.1	Contents . . . . .	181
12.2	Introduction. . . . .	181
12.3	Features . . . . .	182
12.4	Functional Description . . . . .	182
12.4.1	Entering Monitor Mode . . . . .	184
12.4.2	Data Format . . . . .	185
12.4.3	Echoing . . . . .	186
12.4.4	Break Signal . . . . .	186
12.4.5	Commands . . . . .	187
12.4.6	Baud Rate . . . . .	190

## Section 13. Computer Operating Properly Module (COP)

13.1	Contents . . . . .	191
13.2	Introduction. . . . .	192
13.3	Functional Description . . . . .	192
13.4	I/O Signals . . . . .	194
13.4.1	CGMXCLK. . . . .	194
13.4.2	STOP Instruction. . . . .	194
13.4.3	COPCTL Write . . . . .	194
13.4.4	Power-On Reset . . . . .	194
13.4.5	Internal Reset . . . . .	194
13.4.6	Reset Vector Fetch . . . . .	194
13.4.7	COPD . . . . .	195
13.4.8	COPRS . . . . .	195
13.5	COP Control Register. . . . .	195

13.6	Interrupts . . . . .	195
13.7	Monitor Mode . . . . .	196
13.8	Low-Power Modes . . . . .	196
13.8.1	Wait Mode . . . . .	196
13.8.2	Stop Mode . . . . .	196
13.9	COP Module During Break Interrupts . . . . .	196

## Section 14. Low-Voltage Inhibit (LVI)

14.1	Contents . . . . .	197
14.2	Introduction . . . . .	197
14.3	Features . . . . .	198
14.4	Functional Description . . . . .	198
14.4.1	Polled LVI Operation . . . . .	199
14.4.2	Forced Reset Operation . . . . .	199
14.4.3	False Reset Protection . . . . .	200
14.5	LVI Status Register . . . . .	200
14.6	LVI Interrupts . . . . .	201
14.7	Wait Mode . . . . .	201
14.8	Stop Mode . . . . .	201

## Section 15. External Interrupt (IRQ)

15.1	Contents . . . . .	203
15.2	Introduction . . . . .	203
15.3	Features . . . . .	203
15.4	Functional Description . . . . .	204
15.5	$\overline{\text{IRQ}}$ Pin . . . . .	207
15.6	IRQ Module During Break Interrupts . . . . .	208
15.7	IRQ Status and Control Register . . . . .	208

## Section 16. Serial Communications Interface Module (SCI)

16.1	Contents .....	211
16.2	Introduction .....	212
16.3	Features .....	212
16.4	Pin Name Conventions .....	213
16.5	Functional Description .....	213
16.5.1	Data Format .....	216
16.5.2	Transmitter .....	216
16.5.2.1	Character Length .....	216
16.5.2.2	Character Transmission .....	217
16.5.2.3	Break Characters .....	220
16.5.2.4	Idle Characters .....	220
16.5.2.5	Inversion of Transmitted Output .....	221
16.5.2.6	Transmitter Interrupts .....	221
16.5.3	Receiver .....	221
16.5.3.1	Character Length .....	224
16.5.3.2	Character Reception .....	224
16.5.3.3	Data Sampling .....	224
16.5.3.4	Framing Errors .....	227
16.5.3.5	Baud Rate Tolerance .....	227
16.5.3.6	Receiver Wakeup .....	230
16.5.3.7	Receiver Interrupts .....	231
16.5.3.8	Error Interrupts .....	231
16.6	Low-Power Modes .....	232
16.6.1	Wait Mode .....	232
16.6.2	Stop Mode .....	232
16.7	SCI During Break Module Interrupts .....	233
16.8	I/O Signals .....	233
16.8.1	PTE0/SCTxD (Transmit Data) .....	233
16.8.2	PTE1/SCRxD (Receive Data) .....	234

16.9	I/O Registers . . . . .	234
16.9.1	SCI Control Register 1 . . . . .	234
16.9.2	SCI Control Register 2 . . . . .	237
16.9.3	SCI Control Register 3 . . . . .	241
16.9.4	SCI Status Register 1 . . . . .	243
16.9.5	SCI Status Register 2 . . . . .	247
16.9.6	SCI Data Register . . . . .	248
16.9.7	SCI Baud Rate Register . . . . .	249

## Section 17. Serial Peripheral Interface (SPI)

17.1	Contents . . . . .	253
17.2	Introduction . . . . .	254
17.3	Features . . . . .	254
17.4	Pin Name and Register Name Conventions . . . . .	255
17.5	Functional Description . . . . .	256
17.5.1	Master Mode . . . . .	258
17.5.2	Slave Mode . . . . .	259
17.6	Transmission Formats . . . . .	260
17.6.1	Clock Phase and Polarity Controls . . . . .	260
17.6.2	Transmission Format When CPHA = 0 . . . . .	261
17.6.3	Transmission Format When CPHA = 1 . . . . .	262
17.6.4	Transmission Initiation Latency . . . . .	263
17.7	Error Conditions . . . . .	265
17.7.1	Overflow Error . . . . .	265
17.7.2	Mode Fault Error . . . . .	267
17.8	Interrupts . . . . .	269
17.9	Queuing Transmission Data . . . . .	270
17.10	Resetting the SPI . . . . .	272
17.11	Low-Power Modes . . . . .	273
17.11.1	Wait Mode . . . . .	273
17.11.2	Stop Mode . . . . .	273

- 17.12 SPI During Break Interrupts ..... 274
- 17.13 I/O Signals ..... 275
  - 17.13.1 MISO (Master In/Slave Out) ..... 275
  - 17.13.2 MOSI (Master Out/Slave In) ..... 276
  - 17.13.3 SPCK (Serial Clock) ..... 276
  - 17.13.4  $\overline{SS}$  (Slave Select) ..... 277
  - 17.13.5  $V_{SS}$  (Clock Ground)..... 278
- 17.14 I/O Registers. .... 278
  - 17.14.1 SPI Control Register ..... 279
  - 17.14.2 SPI Status and Control Register ..... 281
  - 17.14.3 SPI Data Register ..... 285

## Controller Area Network (CAN) 64-Pin Quad Flat Pack

### Section 18. Timer Interface (TIMA-4)

- 18.1 Contents ..... 289
- 18.2 Introduction ..... 290
- 18.3 Features ..... 290
- 18.4 Functional Description ..... 294
  - 18.4.1 TIMA Counter Prescaler ..... 294
  - 18.4.2 Input Capture. .... 294
  - 18.4.3 Output Compare ..... 296
    - 18.4.3.1 Unbuffered Output Compare ..... 296
    - 18.4.3.2 Buffered Output Compare ..... 297
  - 18.4.4 Pulse Width Modulation (PWM) ..... 298
    - 18.4.4.1 Unbuffered PWM Signal Generation ..... 299
    - 18.4.4.2 Buffered PWM Signal Generation ..... 300
    - 18.4.4.3 PWM Initialization ..... 301
- 18.5 Interrupts. .... 302

18.6	Low-Power Modes	303
18.6.1	Wait Mode	303
18.6.2	Stop Mode	303
18.7	TIMA During Break Interrupts	303
18.8	I/O Signals	304
18.8.1	TIMA Clock Pin (PTD6/ATD14/TCLK)	304
18.8.2	TIMA Channel I/O Pins (PTF1/TACH3–PTF0/TACH2 and PTE3/TACH1–PTE2/TACH0)	305
18.9	I/O Registers	305
18.9.1	TIMA Status and Control Register	305
18.9.2	TIMA Counter Registers	308
18.9.3	TIMA Counter Modulo Registers	309
18.9.4	TIMA Channel Status and Control Registers	310
18.9.5	TIMA Channel Registers	315

## Section 19. Timer Interface (TIMB)

19.1	Contents	319
19.2	Introduction	320
19.3	Features	320
19.4	Functional Description	323
19.4.1	TIMB Counter Prescaler	323
19.4.2	Input Capture	323
19.4.3	Output Compare	325
19.4.3.1	Unbuffered Output Compare	325
19.4.3.2	Buffered Output Compare	326
19.4.4	Pulse Width Modulation (PWM)	326
19.4.4.1	Unbuffered PWM Signal Generation	327
19.4.4.2	Buffered PWM Signal Generation	328
19.4.4.3	PWM Initialization	329
19.5	Interrupts	330



- 19.6 Low-Power Modes ..... 331
  - 19.6.1 Wait Mode ..... 331
  - 19.6.2 Stop Mode ..... 331
- 19.7 TIMB During Break Interrupts ..... 331
- 19.8 I/O Signals ..... 332
  - 19.8.1 TIMB Clock Pin (PTD4/ATD12/TBCLK) ..... 332
  - 19.8.2 TIMB Channel I/O Pins (PTF5/TBCH1–PTF4/TBCH0) . . . 332
- 19.9 I/O Registers ..... 333
  - 19.9.1 TIMB Status and Control Register ..... 333
  - 19.9.2 TIMB Counter Registers ..... 336
  - 19.9.3 TIMB Counter Modulo Registers ..... 337
  - 19.9.4 TIMB Channel Status and Control Registers ..... 338
  - 19.9.5 TIMB Channel Registers ..... 342

## Section 20. Modulo Timer (TIM)

- 20.1 Contents ..... 345
- 20.2 Introduction ..... 345
- 20.3 Features ..... 346
- 20.4 Functional Description ..... 346
- 20.5 TIM Counter Prescaler ..... 348
- 20.6 Low-Power Modes ..... 348
  - 20.6.1 Wait Mode ..... 348
  - 20.6.2 Stop Mode ..... 348
- 20.7 TIM During Break Interrupts ..... 349
- 20.8 I/O Registers ..... 349
  - 20.8.1 TIM Status and Control Register ..... 350
  - 20.8.2 TIM Counter Registers ..... 352
  - 20.8.3 TIM Counter Modulo Registers ..... 353

## Section 21. Analog-to-Digital Converter (ADC-8)

21.1	Contents	355
21.2	Introduction	356
21.3	Features	356
21.4	Functional Description	356
21.4.1	ADC Port I/O Pins	358
21.4.2	Voltage Conversion	358
21.4.3	Conversion Time	359
21.4.4	Continuous Conversion	359
21.4.5	Accuracy and Precision	359
21.5	Interrupts	360
21.6	Low-Power Modes	360
21.6.1	Wait Mode	360
21.6.2	Stop Mode	360
21.7	I/O Signals	361
21.7.1	ADC Analog Power Pin ( $V_{DDAREF}$ )/ADC Voltage Reference Pin ( $V_{REFH}$ )	361
21.7.2	ADC Analog Ground Pin ( $AV_{SS}$ )/ADC Voltage Reference Low Pin ( $V_{REFL}$ )	361
21.7.3	ADC Voltage In (ADCVIN)	361
21.8	I/O Registers	362
21.8.1	ADC Status and Control Register	362
21.8.2	ADC Data Register	365
21.8.3	ADC Input Clock Register	365

## Section 22. MC68HC08AZ32 Emulator Input/Output Ports

22.1	Contents .....	367
22.2	Introduction .....	368
22.3	Port A .....	370
22.3.1	Port A Data Register .....	370
22.3.2	Data Direction Register A .....	371
22.4	Port B .....	373
22.4.1	Port B Data Register .....	373
22.4.2	Data Direction Register B .....	374
22.5	Port C .....	376
22.5.1	Port C Data Register .....	376
22.5.2	Data Direction Register C .....	377
22.6	Port D .....	379
22.6.1	Port D Data Register .....	379
22.6.2	Data Direction Register D .....	380
22.7	Port E .....	382
22.7.1	Port E Data Register .....	382
22.7.2	Data Direction Register E .....	384
22.8	Port F .....	386
22.8.1	Port F Data Register .....	386
22.8.2	Data Direction Register F .....	387
22.9	Port G .....	389
22.9.1	Port G Data Register .....	389
22.9.2	Data Direction Register G .....	390
22.10	Port H .....	392
22.10.1	Port H Data Register .....	392
22.10.2	Data Direction Register H .....	393

**Section 23. MSCAN Controller**

23.1	Contents . . . . .	395
23.2	Introduction . . . . .	396
23.3	Features . . . . .	397
23.4	External Pins . . . . .	398
23.5	Message Storage . . . . .	399
23.5.1	Background . . . . .	399
23.5.2	Receive Structures . . . . .	400
23.5.3	Transmit Structures . . . . .	403
23.6	Identifier Acceptance Filter . . . . .	404
23.7	Interrupts . . . . .	407
23.7.1	Interrupt Acknowledge . . . . .	408
23.7.2	Interrupt Vectors . . . . .	408
23.8	Protocol Violation Protection . . . . .	409
23.9	Low-Power Modes . . . . .	409
23.9.1	MSCAN08 Internal Sleep Mode . . . . .	409
23.9.2	CPU Wait Mode . . . . .	411
23.9.3	CPU Stop Mode . . . . .	411
23.9.4	Programmable Wakeup Function . . . . .	411
23.10	Timer Link . . . . .	411
23.11	Clock System . . . . .	412
23.12	Memory Map . . . . .	415
23.13	Programmer's Model of Message Storage . . . . .	415
23.13.1	Message Buffer Outline . . . . .	416
23.13.2	Identifier Registers . . . . .	417
23.13.3	Data Length Register (DLR) . . . . .	420
23.13.4	Data Segment Registers (DSRn) . . . . .	420
23.13.5	Transmit Buffer Priority Registers . . . . .	421

23.14 Programmer’s Model of Control Registers . . . . . 422

23.14.1 MSCAN08 Module Control Register . . . . . 424

23.14.2 MSCAN08 Module Control Register . . . . . 426

23.14.3 MSCAN08 Bus Timing Register 0 . . . . . 427

23.14.4 MSCAN08 Bus Timing Register 1 . . . . . 428

23.14.5 MSCAN08 Receiver Flag Register (CRFLG) . . . . . 430

23.14.6 MSCAN08 Receiver Interrupt Enable Register . . . . . 432

23.14.7 MSCAN08 Transmitter Flag Register . . . . . 433

23.14.8 MSCAN08 Transmitter Control Register . . . . . 435

23.14.9 MSCAN08 Identifier Acceptance  
Control Register (CIDAC) . . . . . 436

23.14.10 MSCAN08 Receive Error Counter . . . . . 437

23.14.11 MSCAN08 Transmit Error Counter . . . . . 438

23.14.12 MSCAN08 Identifier Acceptance Registers . . . . . 438

23.14.13 MSCAN08 Identifier Mask Registers (CIDMR0-3) . . . . . 440

**Section 24. Keyboard Interrupt Module (KBD)**

24.1 Contents . . . . . 443

24.2 Introduction . . . . . 444

24.3 Features . . . . . 444

24.4 Functional Description . . . . . 444

24.5 Keyboard Initialization . . . . . 447

24.6 Low-Power Modes . . . . . 448

24.6.1 Wait Mode . . . . . 448

24.6.2 Stop Mode . . . . . 448

24.7 Keyboard Module During Break Interrupts . . . . . 448

24.8 I/O Registers . . . . . 449

24.8.1 Keyboard Status and Control Register . . . . . 449

24.8.2 Keyboard Interrupt Enable Register . . . . . 450

## Section 25. Timer Interface (TIMA-6)

25.1	Contents	451
25.2	Introduction	452
25.3	Features	452
25.4	Functional Description	456
25.4.1	TIMA Counter Prescaler	456
25.4.2	Input Capture	456
25.4.3	Output Compare	458
25.4.3.1	Unbuffered Output Compare	458
25.4.3.2	Buffered Output Compare	459
25.4.4	Pulse Width Modulation (PWM)	460
25.4.4.1	Unbuffered PWM Signal Generation	462
25.4.4.2	Buffered PWM Signal Generation	463
25.4.4.3	PWM Initialization	464
25.5	Interrupts	466
25.6	Low-Power Modes	466
25.6.1	Wait Mode	466
25.6.2	Stop Mode	466
25.7	TIMA During Break Interrupts	467
25.8	I/O Signals	467
25.8.1	TIMA Clock Pin (PTD6/ATD14/TCLK)	467
25.8.2	TIMA Channel I/O Pins (PTF3/TACH5–PTF0/TACH2 and PTE3/TACH1–PTE2/TACH0)	468
25.9	I/O Registers	468
25.9.1	TIMA Status and Control Register	469
25.9.2	TIMA Counter Registers	471
25.9.3	TIMA Counter Modulo Registers	472
25.9.4	TIMA Channel Status and Control Registers	473
25.9.5	TIMA Channel Registers	478

## Section 26. Analog-to-Digital Converter (ADC-15)

26.1	Contents	483
26.2	Features	484
26.3	Functional Description	484
26.3.1	ADC Port I/O Pins	485
26.3.2	Voltage Conversion	486
26.3.3	Conversion Time	486
26.3.4	Continuous Conversion	487
26.3.5	Accuracy and Precision	487
26.4	Interrupts	487
26.5	Low-Power Modes	487
26.5.1	Wait Mode	487
26.5.2	Stop Mode	488
26.6	I/O Signals	488
26.6.1	ADC Analog Power Pin ( $V_{DDAREF}$ )/ADC Voltage Reference Pin ( $V_{REFH}$ )	488
26.6.2	ADC Analog Ground Pin ( $V_{SSA}$ )/ADC Voltage Reference Low Pin ( $V_{REFL}$ )	488
26.6.3	ADC Voltage In (ADCVIN)	488
26.7	I/O Registers	489
26.7.1	ADC Status and Control Register	489
26.7.2	ADC Data Register	492
26.7.3	ADC Input Clock Register	492

**Section 27. MC68HC08AS20 Emulator  
Input/Output Ports**

27.1	Contents .....	495
27.2	Introduction .....	496
27.3	Port A .....	498
27.3.1	Port A Data Register .....	498
27.3.2	Data Direction Register A .....	499
27.4	Port B .....	501
27.4.1	Port B Data Register .....	501
27.4.2	Data Direction Register B .....	502
27.5	Port C .....	504
27.5.1	Port C Data Register .....	504
27.5.2	Data Direction Register C .....	505
27.6	Port D .....	507
27.6.1	Port D Data Register .....	507
27.6.2	Data Direction Register D .....	508
27.7	Port E .....	510
27.7.1	Port E Data Register .....	510
27.7.2	Data Direction Register E .....	512
27.8	Port F .....	514
27.8.1	Port F Data Register .....	514
27.8.2	Data Direction Register F .....	515



## Section 28. Byte Data Link Controller–Digital (BDLC–D)

28.1	Contents .....	517
28.2	Introduction .....	519
28.3	Features .....	519
28.4	Functional Description .....	520
28.4.1	BDLC Operating Modes .....	522
28.4.1.1	Power Off Mode .....	522
28.4.1.2	Reset Mode .....	523
28.4.1.3	Run Mode .....	523
28.4.1.4	BDLC Wait Mode .....	523
28.4.1.5	BDLC Stop Mode .....	524
28.4.1.6	Digital Loopback Mode .....	524
28.4.1.7	Analog Loopback Mode .....	524
28.5	BDLC MUX Interface .....	525
28.5.1	Rx Digital Filter .....	526
28.5.1.1	Operation .....	526
28.5.1.2	Performance .....	527
28.5.2	J1850 Frame Format .....	528
28.5.3	J1850 VPW Symbols .....	531
28.5.4	J1850 VPW Valid/Invalid Bits and Symbols .....	534
28.5.5	Message Arbitration .....	538
28.6	BDLC Protocol Handler .....	540
28.6.1	Protocol Architecture .....	541
28.6.2	Rx and Tx Shift Registers .....	541
28.6.3	Rx and Tx Shadow Registers .....	542
28.6.4	Digital Loopback Multiplexer .....	542
28.6.5	State Machine .....	542
28.6.5.1	4X Mode .....	542
28.6.5.2	Receiving a Message in Block Mode .....	543
28.6.5.3	Transmitting a Message in Block Mode .....	543
28.6.5.4	J1850 Bus Errors .....	543
28.6.5.5	Summary .....	545

28.7	BDLC CPU Interface . . . . .	546
28.7.1	BDLC Analog and Roundtrip Delay . . . . .	546
28.7.2	BDLC Control Register 1 . . . . .	548
28.7.3	BDLC Control Register 2 . . . . .	551
28.7.4	BDLC State Vector Register . . . . .	558
28.7.5	BDLC Data Register . . . . .	561
28.8	Low-Power Modes . . . . .	562
28.8.1	Wait Mode . . . . .	562
28.8.2	Stop Mode . . . . .	562

## Section 29. Electrical Specifications

29.1	Contents . . . . .	565
29.2	Maximum Ratings . . . . .	566
29.3	Functional Operating Range . . . . .	567
29.4	Thermal Characteristics . . . . .	567
29.5	5.0 Volt DC Electrical Characteristics . . . . .	568
29.6	Control Timing . . . . .	569
29.7	ADC Characteristics . . . . .	570
29.8	5.0 Vdc $\pm$ 10% Serial Peripheral Interface (SPI) Timing . . . . .	571
29.9	CGM Operating Conditions . . . . .	574
29.10	CGM Component Information . . . . .	574
29.11	CGM Acquisition/Lock Time Information . . . . .	575
29.12	Timer Module Characteristics . . . . .	576
29.13	Memory Characteristics . . . . .	576
29.14	BDLC Transmitter VPW Symbol Timings . . . . .	577
29.15	BDLC Receiver VPW Symbol Timings . . . . .	577

## Section 30. Mechanical Data

30.1	Contents . . . . .	579
30.2	Introduction . . . . .	579
30.3	52-Pin Plastic Leaded Chip Carrier Package (Case 778) . . . .	580
30.4	64-Pin Quad Flat Pack (QFP) . . . . .	581

## Section 31. Ordering Information

31.1	Contents . . . . .	583
31.2	Introduction . . . . .	583
31.3	MC Order Numbers . . . . .	583



# Table of Contents

## List of Figures

Figure	Title	Page
1-1	MCU Block Diagram for the MC68HC08AZ32 Emulator (64-Pin QFP) . . . . .	46
1-2	MCU Block Diagram for the MC68HC08AS20 Emulator (52-Pin PLCC) . . . . .	47
1-3	MC68HC08AZ32 Emulator (64-Pin QFP) . . . . .	48
1-4	MC68HC08AS20 (52-Pin PLCC) . . . . .	49
2-1	Memory Map . . . . .	61
2-2	Control, Status, and Data Registers. . . . .	64
4-1	FLASH Control Register (FLCR) . . . . .	78
4-2	FLASH Block Protect Register (FLBPR) . . . . .	83
5-1	EEPROM Control Register (EECR) . . . . .	92
5-2	EEPROM Nonvolatile Register (EENVR) . . . . .	94
5-3	EEPROM Array Control Register (EEACR) . . . . .	94
6-1	CPU Registers . . . . .	99
6-2	Accumulator (A) . . . . .	99
6-3	Index Register (H:X) . . . . .	100
6-4	Stack Pointer (SP) . . . . .	101
6-5	Program Counter (PC) . . . . .	101
6-6	Condition Code Register (CCR) . . . . .	102
7-1	SIM Block Diagram. . . . .	117
7-2	CGM Clock Signals . . . . .	119
7-3	External Reset Timing . . . . .	121
7-4	Internal Reset Timing . . . . .	122
7-5	Sources of Internal Reset. . . . .	122

Figure	Title	Page
7-6	POR Recovery . . . . .	123
7-7	Interrupt Entry Timing . . . . .	126
7-8	Interrupt Processing . . . . .	127
7-9	Interrupt Recovery Timing . . . . .	128
7-10	Interrupt Recognition Example . . . . .	129
7-11	Wait Mode Entry Timing . . . . .	131
7-12	Wait Recovery from Interrupt or Break . . . . .	132
7-13	Wait Recovery from Internal Reset . . . . .	132
7-14	Stop Mode Entry Timing . . . . .	133
7-15	Stop Mode Recovery from Interrupt or Break . . . . .	134
7-16	SIM Break Status Register (SBSR) . . . . .	134
7-17	SIM Reset Status Register (SRSR) . . . . .	136
7-18	SIM Break Flag Control Register (SBFCR) . . . . .	137
8-1	CGM Block Diagram . . . . .	142
8-2	CGM External Connections . . . . .	151
8-3	PLL Control Register (PCTL) . . . . .	153
8-4	PLL Bandwidth Control Register (PBWC) . . . . .	155
8-5	PLL Programming Register (PPG) . . . . .	157
9-1	Configuration Register (CONFIG-1) . . . . .	168
10-1	Configuration Register (CONFIG-2) . . . . .	172
11-1	Break Module Block Diagram . . . . .	175
11-2	Break Status and Control Register (BSCR) . . . . .	178
11-3	Break Address Registers (BRKH and BRKL) . . . . .	179
12-1	Monitor Mode Circuit . . . . .	183
12-2	Monitor Data Format . . . . .	185
12-3	Sample Monitor Waveforms . . . . .	185
12-4	Read Transaction . . . . .	186
12-5	Break Transaction . . . . .	186
13-1	COP Block Diagram . . . . .	192
13-2	COP Control Register (COPCTL) . . . . .	195

Figure	Title	Page
14-1	LVI Module Block Diagram . . . . .	199
14-2	LVI Status Register (LVISR) . . . . .	200
15-1	IRQ Block Diagram . . . . .	204
15-2	IRQ Interrupt Flowchart . . . . .	206
15-3	IRQ Status and Control Register (ISCR) . . . . .	209
16-1	SCI Module Block Diagram . . . . .	214
16-2	SCI Data Formats . . . . .	216
16-3	SCI Transmitter . . . . .	218
16-4	SCI Receiver Block Diagram . . . . .	222
16-5	Receiver Data Sampling . . . . .	225
16-6	Slow Data . . . . .	227
16-7	Fast Data . . . . .	228
16-8	SCI Control Register 1 (SCC1) . . . . .	235
16-9	SCI Control Register 2 (SCC2) . . . . .	238
16-10	SCI Control Register 3 (SCC3) . . . . .	241
16-11	SCI Status Register 1 (SCS1) . . . . .	243
16-12	Flag Clearing Sequence . . . . .	245
16-13	SCI Status Register 2 (SCS2) . . . . .	247
16-14	SCI Data Register (SCDR) . . . . .	248
16-15	SCI Baud Rate Register (SCBR) . . . . .	249
17-1	SPI Module Block Diagram . . . . .	257
17-2	Full-Duplex Master-Slave Connections . . . . .	258
17-3	Transmission Format (CPHA = 0) . . . . .	261
17-4	Transmission Format (CPHA = 1) . . . . .	262
17-5	Transmission Start Delay (Master) . . . . .	264
17-6	Missed Read of Overflow Condition . . . . .	266
17-7	Clearing SPRF When OVRF Interrupt Is Not Enabled . . . . .	267
17-8	SPI Interrupt Request Generation . . . . .	270
17-9	SPRF/SPTE CPU Interrupt Timing . . . . .	271
17-10	CPHA/ $\overline{SS}$ Timing . . . . .	277
17-11	SPI Control Register (SPCR) . . . . .	279
17-12	SPI Status and Control Register (SPSCR) . . . . .	282
17-13	SPI Data Register (SPDR) . . . . .	285

Figure	Title	Page
18-1	TIMA Block Diagram . . . . .	291
18-2	PWM Period and Pulse Width . . . . .	298
18-3	TIMA Status and Control Register (TASC) . . . . .	306
18-4	TIMA Counter Registers (TACNTH and TACNTL) . . . . .	308
18-5	TIMA Counter Modulo Registers (TAMODH and TAMODL) . . . . .	309
18-6	TIMA Channel Status and Control Registers (TASC0–TASC3) . . . . .	310
18-7	CHxMAX Latency . . . . .	315
18-8	TIMA Channel Registers (TACH0H/L–TACH3H/L) . . . . .	316
19-1	TIMB Block Diagram . . . . .	321
19-2	PWM Period and Pulse Width . . . . .	327
19-3	TIMB Status and Control Register (TBSC) . . . . .	334
19-4	TIMB Counter Registers (TBCNTH and TBCNTL) . . . . .	336
19-5	TIMB Counter Modulo Registers (TMODH and TMODL) . . . . .	337
19-6	TIMB Channel Status and Control Registers (TBSC0–TBSC1) . . . . .	338
19-7	CHxMAX Latency . . . . .	342
19-8	TIMB Channel Registers (TBCH0H/L–TBCH1H/L) . . . . .	343
20-1	TIM Block Diagram . . . . .	347
20-2	TIM Status and Control Register (TSC) . . . . .	350
20-3	TIM Counter Registers (TCNTH–TCNTL) . . . . .	352
20-4	TIM Counter Modulo Registers (TMODH–TMODL) . . . . .	353
21-1	ADC Block Diagram . . . . .	357
21-2	ADC Status and Control Register (ADSCR) . . . . .	362
21-3	ADC Data Register (ADR) . . . . .	365
21-4	ADC Input Clock Register (ADICLK) . . . . .	365
22-1	Port A Data Register (PTA) . . . . .	370
22-2	Data Direction Register A (DDRA) . . . . .	371



Figure	Title	Page
22-3	Port A I/O Circuit . . . . .	371
22-4	Port B Data Register (PTB) . . . . .	373
22-5	Data Direction Register B (DDRB) . . . . .	374
22-6	Port B I/O Circuit . . . . .	374
22-7	Port C Data Register (PTC) . . . . .	376
22-8	Data Direction Register C (DDRC) . . . . .	377
22-9	Port C I/O Circuit . . . . .	378
22-10	Port D Data Register (PTD) . . . . .	379
22-11	Data Direction Register D (DDRD) . . . . .	380
22-12	Port D I/O Circuit . . . . .	380
22-13	Port E Data Register (PTE) . . . . .	382
22-14	Data Direction Register E (DDRE) . . . . .	384
22-15	Port E I/O Circuit . . . . .	385
22-16	Port F Data Register (PTF) . . . . .	386
22-17	Data Direction Register F (DDRF) . . . . .	387
22-18	Port F I/O Circuit . . . . .	388
22-19	Port G Data Register (PTG) . . . . .	389
22-20	Data Direction Register G (DDRG) . . . . .	390
22-21	Port G I/O Circuit . . . . .	390
22-22	Port H Data Register (PTH) . . . . .	392
22-23	Data Direction Register H (DDRH) . . . . .	393
22-24	Port H I/O Circuit . . . . .	393
23-1	The CAN System . . . . .	398
23-2	User Model for Message Buffer Organization . . . . .	402
23-3	Single 32-Bit Maskable Identifier Acceptance Filter . . . . .	405
23-4	Dual 16-Bit Maskable Acceptance Filters . . . . .	405
23-5	Quadruple 8-Bit Maskable Acceptance Filters . . . . .	406
23-6	Sleep Request/Acknowledge Cycle . . . . .	410
23-7	Clocking Scheme . . . . .	412
23-8	Segments within the Bit Time . . . . .	414
23-9	MSCAN08 Memory Map . . . . .	415
23-10	Message Buffer Organization . . . . .	416
23-11	Receive/Transmit Message Buffer Extended Identifier (IDRn) . . . . .	418
23-12	Standard Identifier Mapping . . . . .	419

Figure	Title	Page
23-13	Transmit Buffer Priority Register (TBPR) . . . . .	421
23-14	MSCAN08 Control Register Structure . . . . .	422
23-15	Module Control Register 0 (CMCR0) . . . . .	424
23-16	Module Control Register (CMCR1) . . . . .	426
23-17	Bus Timing Register 0 (CBTR0) . . . . .	427
23-18	Bus Timing Register 1 (CBTR1) . . . . .	428
23-19	Receiver Flag Register (CRFLG) . . . . .	430
23-20	Receiver Interrupt Enable Register (CRIER) . . . . .	432
23-21	Transmitter Flag Register (CTFLG) . . . . .	433
23-22	Transmitter Control Register (CTCR) . . . . .	435
23-23	Identifier Acceptance Control Register (CIDAC) . . . . .	436
23-24	Receiver Error Counter (CRXERR) . . . . .	437
23-25	Transmit Error Counter (CTXERR) . . . . .	438
23-26	Identifier Acceptance Registers (CIDAR0–CIDAR3) . . . . .	439
23-27	Identifier Mask Registers (CIDMR0–CIDMR3) . . . . .	440
24-1	Keyboard Module Block Diagram . . . . .	445
24-2	Keyboard Status and Control Register (KBSCR) . . . . .	449
24-3	Keyboard Interrupt Enable Register (KBIER) . . . . .	450
25-1	TIMA Block Diagram . . . . .	453
25-2	PWM Period and Pulse Width . . . . .	461
25-3	TIMA Status and Control Register (TASC) . . . . .	469
25-4	TIMA Counter Registers (TCNTH and TCNTL) . . . . .	471
25-5	TIMA Counter Modulo Registers (TAMODH and TAMODL) . . . . .	472
25-6	TIMA Channel Status and Control Registers (TACC0–TASC5) . . . . .	473
25-7	CHxMAX Latency . . . . .	478
25-8	TIMA Channel Registers (TACH0H/L–TACH3H/L) . . . . .	479
26-1	ADC Block Diagram . . . . .	485
26-2	ADC Status and Control Register (ADSCR) . . . . .	489
26-3	ADC Data Register (ADR) . . . . .	492
26-4	ADC Input Clock Register (ADICLK) . . . . .	492

Figure	Title	Page
27-1	Port A Data Register (PTA) . . . . .	498
27-2	Data Direction Register A (DDRA) . . . . .	499
27-3	Port A I/O Circuit . . . . .	499
27-4	Port B Data Register (PTB) . . . . .	501
27-5	Data Direction Register B (DDRB) . . . . .	502
27-6	Port B I/O Circuit . . . . .	502
27-7	Port C Data Register (PTC) . . . . .	504
27-8	Data Direction Register C (DDRC) . . . . .	505
27-9	Port C I/O Circuit . . . . .	506
27-10	Port D Data Register (PTD) . . . . .	507
27-11	Data Direction Register D (DDRD) . . . . .	508
27-12	Port D I/O Circuit . . . . .	509
27-13	Port E Data Register (PTE) . . . . .	510
27-14	Data Direction Register E (DDRE) . . . . .	512
27-15	Port E I/O Circuit . . . . .	513
27-16	Data Direction Register E (DDRE) . . . . .	514
27-17	Data Direction Register F (DDRF) . . . . .	515
27-18	Port F I/O Circuit . . . . .	515
28-1	BDLC Block Diagram . . . . .	520
28-2	BDLC Operating Modes State Diagram . . . . .	522
28-3	BDLC Block Diagram . . . . .	525
28-4	BDLC Rx Digital Filter Block Diagram . . . . .	526
28-5	J1850 Bus Message Format (VPW) . . . . .	528
28-6	J1850 VPW Symbols with Nominal Symbol Times . . . . .	532
28-7	J1850 VPW Received Passive Symbol Times . . . . .	535
28-8	J1850 VPW Received Passive EOF and IFS Symbol Times . . . . .	536
28-9	J1850 VPW Received Active Symbol Times . . . . .	537
28-10	J1850 VPW Received BREAK Symbol Times . . . . .	538
28-11	J1850 VPW Bitwise Arbitrations . . . . .	539
28-12	BDLC Block Diagram . . . . .	540
28-13	BDLC Protocol Handler Outline . . . . .	541
28-14	BDLC Block Diagram . . . . .	546
28-15	BDLC Analog and Roundtrip Delay Register (BARD) . . . . .	546
28-16	BDLC Control Register 1 (BCR1) . . . . .	548

Figure	Title	Page
28-17	BDLC Control Register 2 (BCR2) . . . . .	551
28-18	Types of In-Frame Response (IFR) . . . . .	555
28-19	BDLC State Vector Register (BSVR) . . . . .	559
28-20	BDLC Data Register (BDR) . . . . .	561
29-1	SPI Master Timing Diagram . . . . .	572
29-2	SPI Slave Timing Diagram . . . . .	573
29-3	BDLC Variable Pulse Width Modulation (VPW) Symbol Timing . . . . .	578



## List of Tables

Table	Title	Page
1-1	Feature Comparisons . . . . .	42
1-2	External Pins Summary . . . . .	55
1-3	Clock Source Summary . . . . .	57
2-1	Vector Addresses . . . . .	73
4-1	Charge Pump Clock Frequency . . . . .	80
4-2	Erase Block Sizes. . . . .	81
5-1	EEPROM Program/Erase Cycling Reduction. . . . .	89
5-2	EEPROM Array Address Blocks. . . . .	90
5-3	EEPROM Program/Erase Mode Select . . . . .	93
6-1	Instruction Set Summary . . . . .	106
6-2	Opcode Map. . . . .	114
7-1	SIM I/O Register Summary. . . . .	118
7-2	I/O Register Address Summary . . . . .	118
7-3	Signal Name Conventions . . . . .	118
7-4	PIN Bit Set Timing . . . . .	121
8-1	I/O Register Summary . . . . .	143
8-2	I/O Register Address Summary . . . . .	143
8-3	VCO Frequency Multiplier (N) Selection. . . . .	158
11-1	I/O Register Summary . . . . .	175
11-2	I/O Register Address Summary . . . . .	175

Table	Title	Page
12-1	Mode Selection . . . . .	184
12-2	Mode Differences . . . . .	185
12-3	READ (Read Memory) Command . . . . .	187
12-4	WRITE (Write Memory) Command . . . . .	188
12-5	IREAD (Indexed Read) Command . . . . .	188
12-6	IWRITE (Indexed Write) Command . . . . .	189
12-7	READSP (Read Stack Pointer) Command . . . . .	189
12-8	RUN (Run User Program) Command . . . . .	190
12-9	Monitor Baud Rate Selection . . . . .	190
14-1	LVI I/O Register Summary . . . . .	199
14-2	LVIOUT Bit Indication . . . . .	200
15-1	IRQ I/O Register Summary . . . . .	205
16-1	Pin Name Conventions . . . . .	213
16-2	SCI I/O Register Summary . . . . .	215
16-3	SCI I/O Register Address Summary . . . . .	215
16-4	SCI Transmitter I/O Register Summary . . . . .	219
16-5	SCI Transmitter I/O Address Summary . . . . .	219
16-6	SCI Receiver I/O Register Summary . . . . .	223
16-7	SCI Receiver I/O Address Summary . . . . .	223
16-8	Start Bit Verification . . . . .	225
16-9	Data Bit Recovery . . . . .	226
16-10	Stop Bit Recovery . . . . .	226
16-11	Character Format Selection . . . . .	237
16-12	SCI Baud Rate Prescaling . . . . .	249
16-13	SCI Baud Rate Selection . . . . .	250
16-14	SCI Baud Rate Selection Examples . . . . .	251
17-1	Pin Name Conventions . . . . .	255
17-2	I/O Register Addresses . . . . .	255
17-3	SPI I/O Register Summary . . . . .	256
17-4	SPI Interrupts . . . . .	269
17-5	SPI Configuration . . . . .	278
17-6	SPI Master Baud Rate Selection . . . . .	284

<b>Table</b>	<b>Title</b>	<b>Page</b>
18-1	TIM I/O Register Summary . . . . .	292
18-2	Prescaler Selection . . . . .	307
18-3	Mode, Edge, and Level Selection . . . . .	314
19-1	TIMB I/O Register Summary . . . . .	322
19-2	Prescaler Selection . . . . .	335
19-3	Mode, Edge, and Level Selection . . . . .	341
20-1	TIM I/O Register Summary . . . . .	347
20-2	TIM I/O Register Address Summary . . . . .	347
20-3	Prescaler Selection . . . . .	351
21-1	Mux Channel Select . . . . .	364
21-2	ADC Clock Divide Ratio . . . . .	366
22-1	MC68HC08AZ32 Emulator I/O Port Register Summary . . . . .	368
22-2	Port A Pin Functions . . . . .	372
22-3	Port B Pin Functions . . . . .	375
22-4	Port C Pin Functions . . . . .	378
22-5	Port D Pin Functions . . . . .	381
22-6	Port E Pin Functions . . . . .	385
22-7	Port F Pin Functions . . . . .	388
22-8	Port G Pin Functions . . . . .	391
22-9	Port H Pin Functions . . . . .	394
23-1	MSCAN08 Interrupt Vector Addresses . . . . .	408
23-2	CAN Standard Compliant Bit Time Segment Settings . . . . .	414
23-3	Data Length Codes . . . . .	420
23-4	Synchronization Jump Width . . . . .	427
23-5	Baud Rate Prescaler . . . . .	427
23-6	Time Segment Syntax . . . . .	428
23-7	Time Segment Values . . . . .	429
23-8	Identifier Acceptance Mode Settings . . . . .	436
23-9	Identifier Acceptance Hit Indication . . . . .	437

Table	Title	Page
24-1	I/O Register Summary . . . . .	445
24-2	I/O Register Address Summary . . . . .	445
25-1	TIMA I/O Register Summary . . . . .	454
25-2	Prescaler Selection. . . . .	470
25-3	Mode, Edge, and Level Selection. . . . .	477
26-1	Mux Channel Select . . . . .	491
26-2	ADC Clock Divide Ratio . . . . .	493
27-1	MC68HC08AS20 Emulator I/O Port Register Summary . . .	496
27-2	Port A Pin Functions. . . . .	500
27-3	Port B Pin Functions. . . . .	503
27-4	Port C Pin Functions. . . . .	506
27-5	Port D Pin Functions. . . . .	509
27-6	Port E Pin Functions. . . . .	513
27-7	Port F Pin Functions. . . . .	516
28-1	BDLC Input/Output (I/O) Register Summary . . . . .	521
28-2	BDLC J1850 Bus Error Summary. . . . .	545
28-3	BDLC Transceiver Delay . . . . .	548
28-4	BDLC Rate Selection . . . . .	550
28-5	BDLC Transmit In-Frame Response Control Bit Priority Encoding . . . . .	554
28-6	BDLC Interrupt Sources . . . . .	559
31-1	MC Order Numbers . . . . .	583



## Section 1. General Description

### 1.1 Contents

1.2	Introduction . . . . .	42
1.3	Features . . . . .	42
1.4	MCU Block Diagram . . . . .	45
1.5	Pin Assignments . . . . .	48
1.5.1	Power Supply Pins ( $V_{DD}$ and $V_{SS}$ ) . . . . .	50
1.5.2	Oscillator Pins (OSC1 and OSC2) . . . . .	51
1.5.3	External Reset Pin ( $\overline{RST}$ ) . . . . .	51
1.5.4	External Interrupt Pin ( $\overline{IRQ}$ ) . . . . .	51
1.5.5	Analog Power Supply Pin ( $V_{DDA}$ ) . . . . .	51
1.5.6	Analog Ground Pin ( $V_{SSA}$ ) . . . . .	51
1.5.7	External Filter Capacitor Pin (CGMXFC) . . . . .	52
1.5.8	Port A Input/Output (I/O) Pins (PTA7–PTA0) . . . . .	52
1.5.9	Port B I/O Pins (PTB7/ATD7–PTB0/ATD0) . . . . .	52
1.5.10	Port C I/O Pins (PTC5–PTC0) . . . . .	52
1.5.11	Port D I/O Pins (PTD7/ATD15–PTD0/ATD8) . . . . .	52
1.5.12	Port E I/O Pins (PTE7/SPSCK–PTE0/TxD) . . . . .	53
1.5.13	Port F I/O Pins (PTF6–PTF0/TACH2) . . . . .	53
1.5.14	Port G I/O Pins (PTG2/KBD2–PTG0/KBD0) . . . . .	53
1.5.15	Port H I/O Pins (PTH1/KBD4–PTH0/KBD3) . . . . .	54
1.5.16	CAN Transmit Pin (CANTx)/BDLC Transmit Pin (BDTxD) . . . . .	54
1.5.17	CAN Receive Pin (CANRx)/BDLC Receive Pin (BDRxD) . . . . .	54

## 1.2 Introduction










The MC68HC908AT32 is a member of the low-cost, high-performance M68HC08 Family of 8-bit microcontroller units (MCUs). The M68HC08 Family is based on the customer-specified integrated circuit (CSIC) design strategy. All MCUs in the family use the enhanced M68HC08 central processor unit (CPU08) and are available with a variety of modules, memory sizes and types, and package types.

This part is designed to emulate two separate automotive parts: the MC68HC08AZ32 and the MC68HC08AS20. This document demonstrates the unique qualities of both parts. In the case of similarities, these are explained in the beginning sections of the specification.

## 1.3 Features

Refer to [Table 1-1](#) for an encapsulated feature list comparison between the MC68HC08AZ32 and MC68HC08AS20.









**Table 1-1. Feature Comparisons**

Features	MC68HC08AZ32 64-Pin Emulator	MC68HC08AS20 52-Pin Emulator
8-Bit 8-Channel Analog-to-Digital Converter (ADC-8)		
8-Bit 15-Channel Analog-to-Digital Converter (ADC-15)		
J1850 Byte Data Link Controller-Digital (BDLC)		
Break Module (BRK)		
Controller Area Network (CAN)		
512 Bytes Electrically Erasable Programmable Read-Only Memory (EEPROM)		
32-K FLASH		

**Table 1-1. Feature Comparisons (Continued)**

Features	MC68HC08AZ32 64-Pin Emulator	MC68HC08AS20 52-Pin Emulator
20-K FLASH		
5-Bit Keyboard Interrupt Module (KBD)		
Low-Voltage Inhibit (LVI)		
1-K Random-Access Memory (RAM)		
640 Bytes RAM		
Monitor Read-Only Memory (ROM)		
Serial Communications Interface (SCI)		
Serial Peripheral Interface (SPI)		
2-Channel Timer (TIMB)		
4-Channel Timer (TIMA-4)		
6-Channel Timer (TIMA-6)		
Periodic Interrupt Timer (TIM)		
Port A (PTA)		
Port B (PTB)		
Port C (PTC)	 (PTC5:PTC0)	 (PTC4:PTC0)

**Table 1-1. Feature Comparisons (Continued)**

Features	MC68HC08AZ32 64-Pin Emulator	MC68HC08AS20 52-Pin Emulator
Port D (PTD)	 (PTD7:PTD0)	 (PTD6:PTD0)
Port E (PTE)		
Port F (PTF)	 (PTF6:PTF0)	 (PTF3:PTF0)
Port G (PTG)		
Port H (PTH)		

Features of the MC68HC908AT32 include:

- High-Performance M68HC08 Architecture
- Fully Upward-Compatible Object Code with M6805, M146805, and M68HC05 Families
- 8-MHz Internal Bus Frequency
- 32 Kbytes of FLASH Electrically Erasable Read-Only Memory (FLASH)
- FLASH Data Security
- 512 Bytes of On-Chip Electrically Erasable Programmable Read-Only Memory with Security Option (EEPROM)
- 1 Kbyte of On-Chip RAM
- Clock Generator Module (CGM)
- Serial Peripheral Interface Module (SPI)
- Serial Communications Interface Module (SCI)
- System Protection Features
  - Computer Operating Properly (COP) with Optional Reset
  - Low-Voltage Detection with Optional Reset
  - Illegal Opcode Detection with Optional Reset
  - Illegal Address Detection with Optional Reset
- Low-Power Design (Fully Static with Stop and Wait Modes)

- Master Reset Pin and Power-On Reset

Features of the CPU08 include:

- Enhanced HC05 Programming Model
- Extensive Loop Control Functions
- 16 Addressing Modes (Eight More Than the HC05)
- 16-Bit Index Register and Stack Pointer
- Memory-to-Memory Data Transfers
- Fast  $8 \times 8$  Multiply Instruction
- Fast 16/8 Divide Instruction
- Binary-Coded Decimal (BCD) Instructions
- Optimization for Controller Applications
- C Language Support

Features of the MC68HC08AZ32 Emulator (64-Pin QFP) not listed above include:

- 16-Bit, 4-Channel Timer Interface Module (TIMA-4)
- 16-Bit, 2-Channel Timer Interface Module (TIMB)
- Periodic Interrupt Timer (PIT)
- 5-Bit Keyboard Interrupt Module (KBD)
- 8-Bit, 8-Channel Analog-to-Digital Converter Module (ADC-8)
- MSCAN (Scalable CAN) Controller Implements CAN 2.0b Protocol as Defined in BOSCH Specification September 1991)

Features of the MC68HC08AS20 Emulator (52-Pin PLCC) not listed above include:

- 8-Bit, 15-Channel Analog-to-Digital Converter (ADC-15)
- 16-Bit, 6-Channel Timer Interface Module (TIMA-6)
- SAE J1850 Byte Data Link Controller Digital Module (BDLC-D)

## 1.4 MCU Block Diagram

[Figure 1-1](#) and [Figure 1-2](#) show the structure of the MC68HC908AT32.

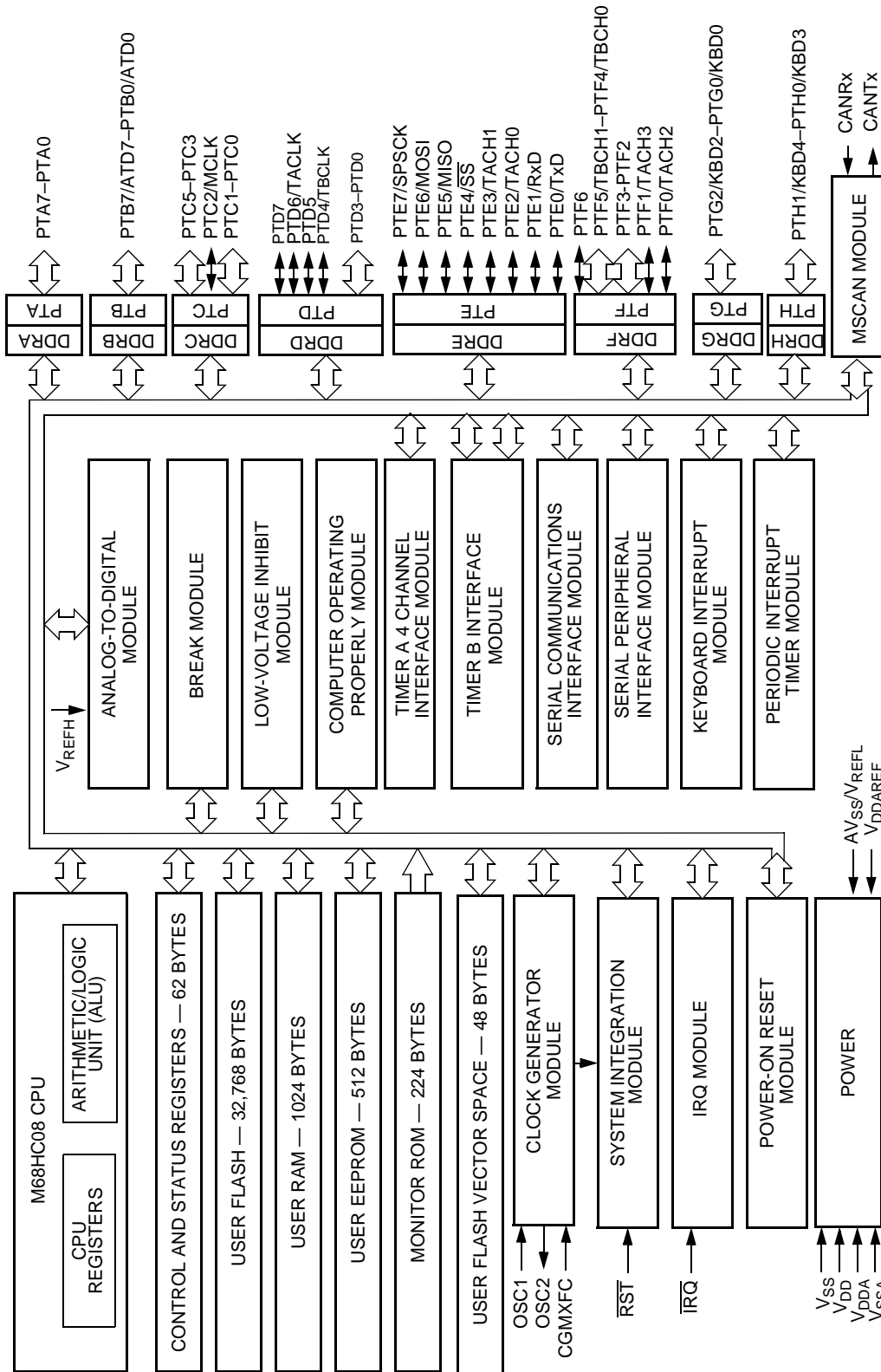
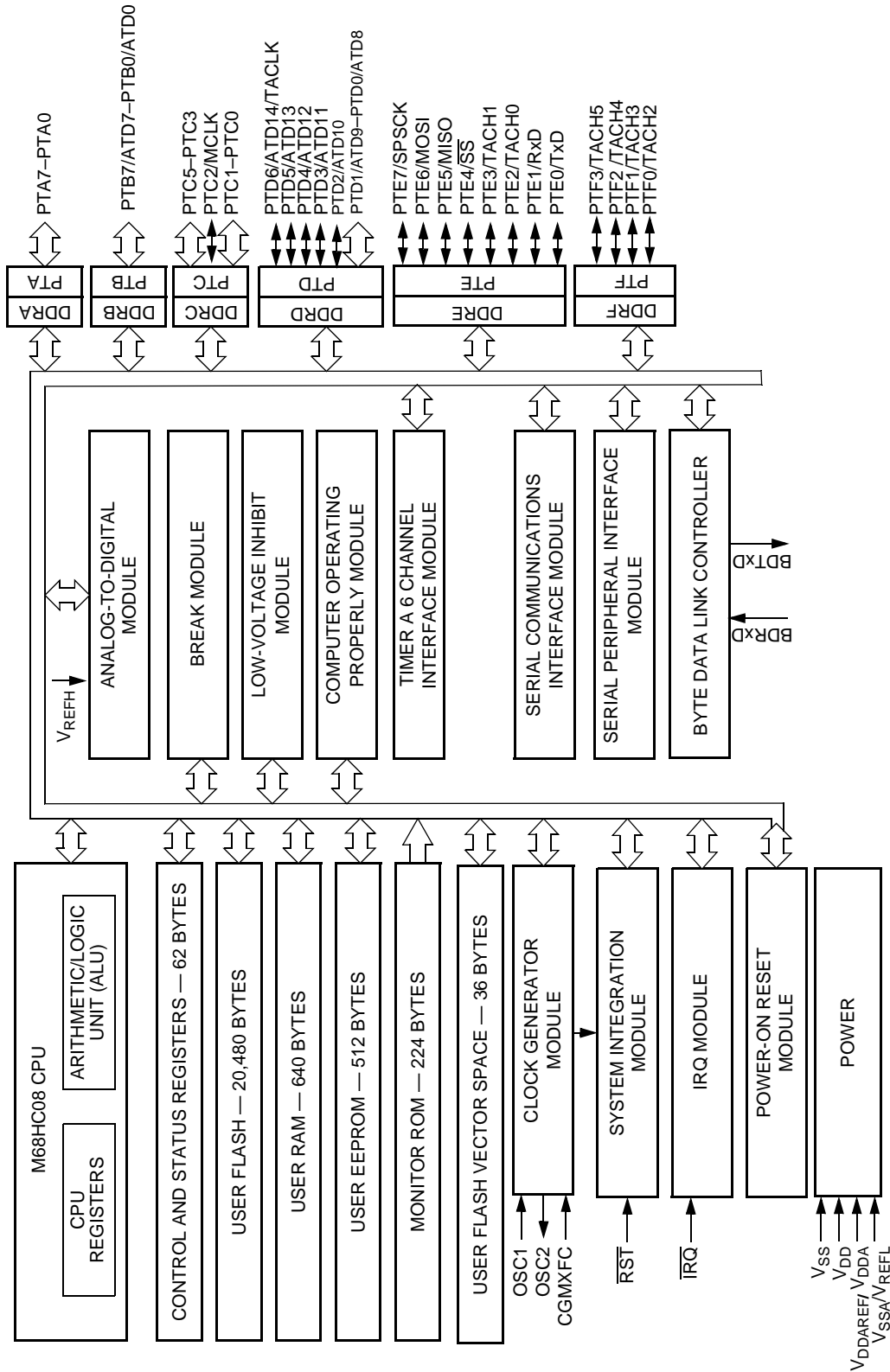


Figure 1-1. MCU Block Diagram for the MC68HC08AZ32 Emulator (64-Pin QFP)



**Figure 1-2. MCU Block Diagram for the MC68HC08AS20 Emulator (52-Pin PLCC)**



## 1.5 Pin Assignments

Figure 1-3 shows the MC68HC08AZ32 emulator assignments.

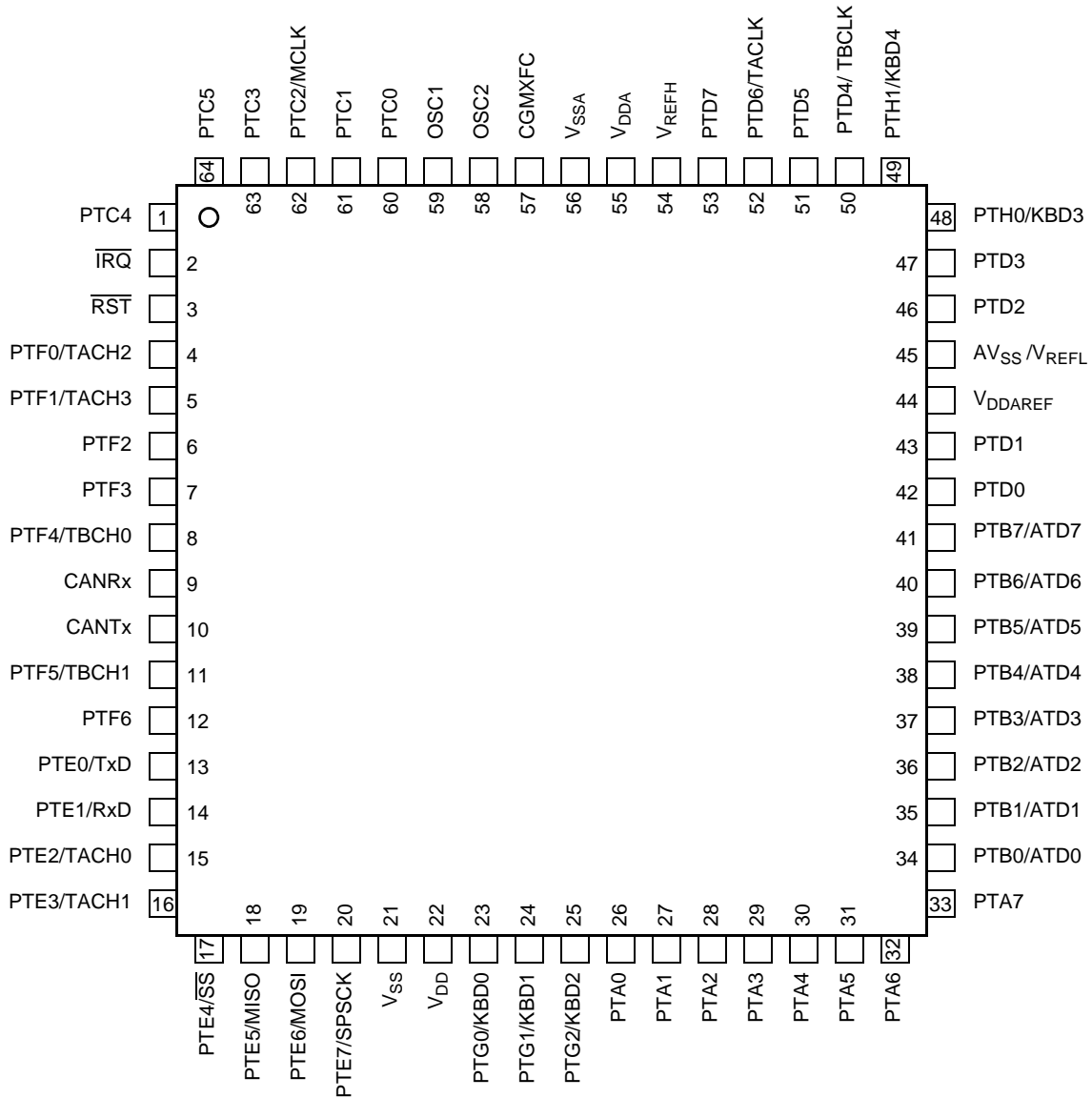
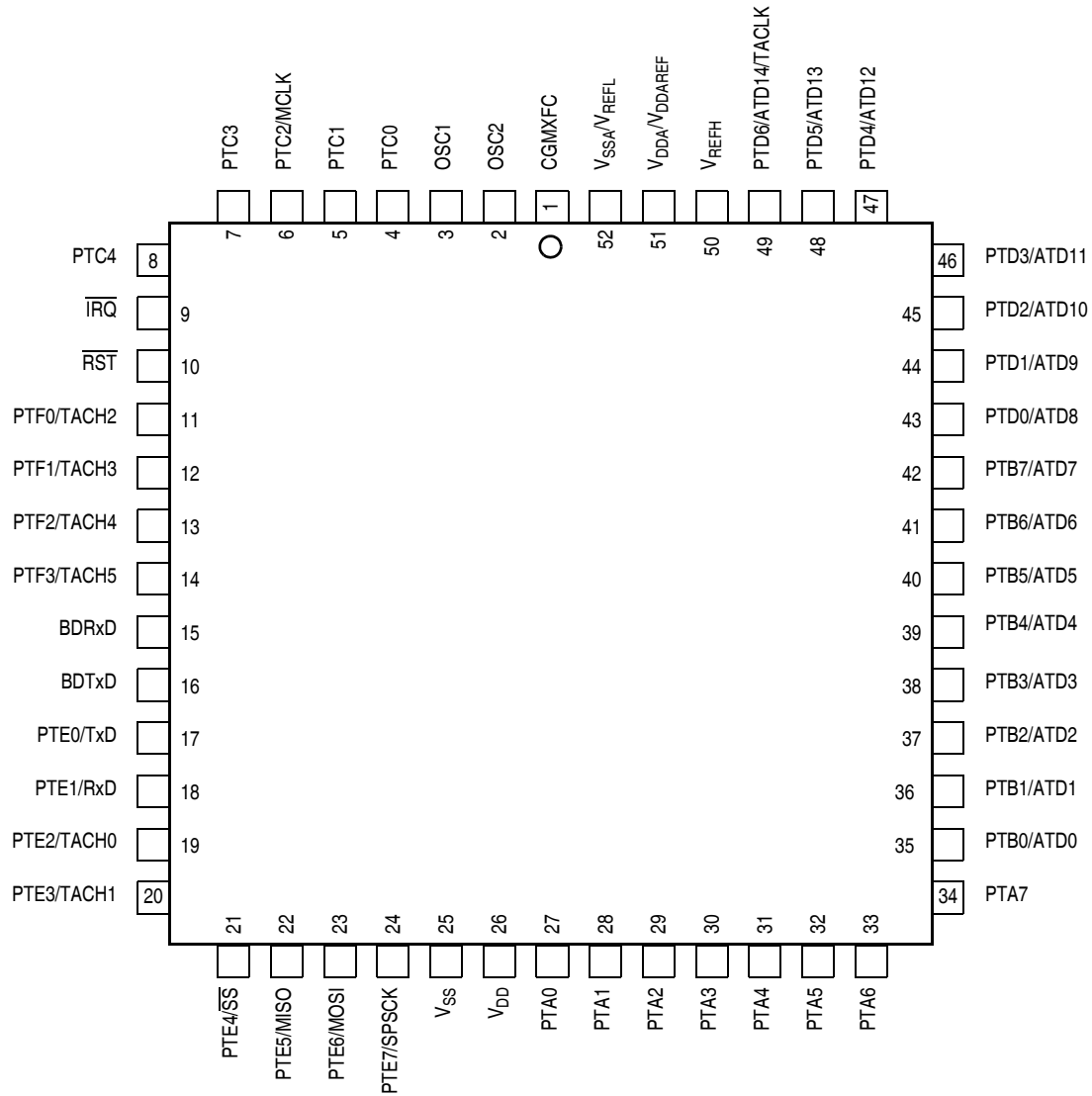


Figure 1-3. MC68HC08AZ32 Emulator (64-Pin QFP)

Figure 1-4 shows MC68HC08AS20 emulator assignments.



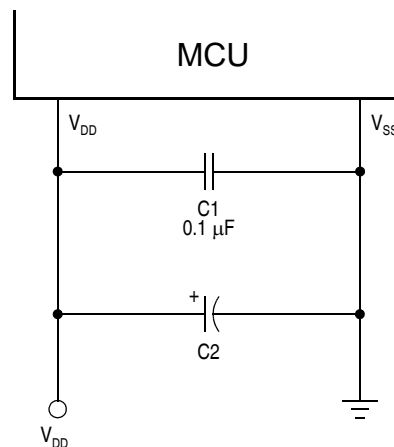
**Figure 1-4. MC68HC08AS20 (52-Pin PLCC)**

**NOTE:** The following pin descriptions are just a quick reference. For a more detailed representation, see [Section 22. MC68HC08AZ32 Emulator Input/Output Ports](#) and [Section 27. MC68HC08AS20 Emulator Input/Output Ports](#).

### 1.5.1 Power Supply Pins ( $V_{DD}$ and $V_{SS}$ )

$V_{DD}$  and  $V_{SS}$  are the power supply and ground pins. The MCU operates from a single power supply.

Fast signal transitions on MCU pins place high, short-duration current demands on the power supply. To prevent noise problems, take special care to provide power supply bypassing at the MCU as shown. Place the C1 bypass capacitor as close to the MCU as possible. Use a high-frequency response ceramic capacitor for C1. C2 is an optional bulk current bypass capacitor for use in applications that require the port pins to source high current levels.



NOTE: Component values shown represent typical applications.

$V_{SS}$  is also the ground for the port output buffers and the ground return for the serial clock in the serial peripheral interface module (SPI). (See [Section 17. Serial Peripheral Interface \(SPI\)](#).)

**NOTE:**  $V_{SS}$  must be grounded for proper MCU operation.

### 1.5.2 Oscillator Pins (OSC1 and OSC2)

The OSC1 and OSC2 pins are the connections for the on-chip oscillator circuit. (See [Section 8. Clock Generator Module \(CGM\)](#).)

### 1.5.3 External Reset Pin ( $\overline{\text{RST}}$ )

A logic 0 on the  $\overline{\text{RST}}$  pin forces the MCU to a known startup state.  $\overline{\text{RST}}$  is bidirectional, allowing a reset of the entire system. It is driven low when any internal reset source is asserted. (See [Section 7. System Integration Module \(SIM\)](#) for more information.)

### 1.5.4 External Interrupt Pin ( $\overline{\text{IRQ}}$ )

$\overline{\text{IRQ}}$  is an asynchronous external interrupt pin. (See [Section 15. External Interrupt \(IRQ\)](#).)

### 1.5.5 Analog Power Supply Pin ( $V_{\text{DDA}}$ )

$V_{\text{DDA}}$  is the power supply pin for the analog portion of the chip. For the MC68HC08AZ32 emulator protocol, this pin will supply the clock generator module (CGM). However, for the MC68HC08AS20 emulator protocol this pin will supply both the clock generator module and the analog-to-digital converter (ADC). (See [Section 8. Clock Generator Module \(CGM\)](#) and [Section 26. Analog-to-Digital Converter \(ADC-15\)](#).)

### 1.5.6 Analog Ground Pin ( $V_{\text{SSA}}$ )

The  $V_{\text{SSA}}$  analog ground pin is used only for the ground connections for the analog sections of the circuit and should be decoupled as per the  $V_{\text{SS}}$  digital ground pin. This will only supply the clock generator module on the MC68HC08AZ32 emulator part. The analog sections consist of a clock generator module (CGM) and an analog-to-digital converter (ADC) for the MC68HC08AS20 emulator part. (See [Section 8. Clock Generator Module \(CGM\)](#) and [Section 26. Analog-to-Digital Converter \(ADC-15\)](#).)

### 1.5.7 External Filter Capacitor Pin (CGMXFC)

CGMXFC is an external filter capacitor connection for the CGM. (See [Section 8. Clock Generator Module \(CGM\)](#).)

### 1.5.8 Port A Input/Output (I/O) Pins (PTA7–PTA0)

PTA7–PTA0 are general-purpose bidirectional I/O port pins. See [Section 22. MC68HC08AZ32 Emulator Input/Output Ports](#) or [Section 27. MC68HC08AS20 Emulator Input/Output Ports](#) depending on your configuration.

### 1.5.9 Port B I/O Pins (PTB7/ATD7–PTB0/ATD0)

Port B is an 8-bit special function port that shares all eight pins with the analog-to-digital converter (ADC). See [Section 26. Analog-to-Digital Converter \(ADC-15\)](#) and [Section 22. MC68HC08AZ32 Emulator Input/Output Ports](#) or [Section 27. MC68HC08AS20 Emulator Input/Output Ports](#) depending on your configuration.

### 1.5.10 Port C I/O Pins (PTC5–PTC0)

PTC5–PTC3 and PTC1–PTC0 are general-purpose bidirectional I/O port pins. PTC2/MCLK is a special function port that shares its pin with the system clock. See [Section 22. MC68HC08AZ32 Emulator Input/Output Ports](#) or [Section 27. MC68HC08AS20 Emulator Input/Output Ports](#) depending on your configuration.

**NOTE:** *PTC5 is available only in 64-pin packages.*

### 1.5.11 Port D I/O Pins (PTD7/ATD15–PTD0/ATD8)

Port D is an 8-bit special-function port that shares all of its pins with the analog-to-digital converter module (ADC-15), and one of its pins with the timer interface module (TIMA) if the part is configured as MC68HC08AS20. If the part is configured as MC68HC08AZ32, then port D shares one of its pins with the 4-channel interface module (TIMA), and one of its pins with the 2-channel interface module (TIMB). See [Section](#)

[25. Timer Interface \(TIMA-6\)](#) and [Section 26. Analog-to-Digital Converter \(ADC-15\)](#) or [Section 18. Timer Interface \(TIMA-4\)](#), [Section 19. Timer Interface \(TIMB\)](#), and [Section 21. Analog-to-Digital Converter \(ADC-8\)](#) depending on your configuration.

### 1.5.12 Port E I/O Pins (PTE7/SPSCK–PTE0/TxD)

Port E is an 8-bit special function port that shares two of its pins with the timer interface module (TIMA), four of its pins with the serial peripheral interface module (SPI), and two of its pins with the serial communication interface module (SCI). (See [Section 16. Serial Communications Interface Module \(SCI\)](#), [Section 17. Serial Peripheral Interface \(SPI\)](#), [Section 18. Timer Interface \(TIMA-4\)](#) or [Section 25. Timer Interface \(TIMA-6\)](#), and [Section 22. MC68HC08AZ32 Emulator Input/Output Ports](#) or [Section 27. MC68HC08AS20 Emulator Input/Output Ports](#) depending on your configuration.)

### 1.5.13 Port F I/O Pins (PTF6–PTF0/TACH2)

Port F is a 7-bit special function port that shares its pins with the timer interface module (TIMB) if the part is configured as MC68HC08AZ32 emulator protocol. If the part is configured as MC68HC08AS20 emulator protocol, four of its pins will be shared with the timer interface module (TIMA-6). (See [Section 18. Timer Interface \(TIMA-4\)](#) or [Section 25. Timer Interface \(TIMA-6\)](#), [Section 19. Timer Interface \(TIMB\)](#), and [Section 22. MC68HC08AZ32 Emulator Input/Output Ports](#) or [Section 27. MC68HC08AS20 Emulator Input/Output Ports](#) depending on your configuration.)

**NOTE:** *PTF4–PTF6 is available only in 64-pin packages.*

### 1.5.14 Port G I/O Pins (PTG2/KBD2–PTG0/KBD0)

**NOTE:** *This port is available only in the MC68HC08AZ32 emulator.*

Port G is a 3-bit special function port that shares all of its pins with the keyboard interrupt module (KBD) only if the part is configured as MC68HC08AZ32 Emulator (64-pin QFP) protocol. If port G is available

and MC68HC08AS20 emulation is selected, this port will be general I/O only. (See [Section 24. Keyboard Interrupt Module \(KBD\)](#) and [Section 22. MC68HC08AZ32 Emulator Input/Output Ports.](#))

#### 1.5.15 Port H I/O Pins (PTH1/KBD4–PTH0/KBD3)

**NOTE:** *This port is available only in the MC68HC08AZ32 emulator.*

Port H is a 2-bit special-function port that shares all of its pins with the keyboard interrupt module (KBD) only if the part is configured as MC68HC08AZ32 emulator protocol. If port H is available and MC68HC08AS20 emulation is selected, this port will be general I/O only. (See [Section 24. Keyboard Interrupt Module \(KBD\)](#) and [Section 22. MC68HC08AZ32 Emulator Input/Output Ports.](#))

#### 1.5.16 CAN Transmit Pin (CANTx)/BDLC Transmit Pin (BDTxD)

If the part is configured as MC68HC08AZ32 emulator protocol, this pin is the digital output from the CAN module (CANTx). Otherwise, if the part is configured as MC68HC08AS20 emulator protocol this pin is the serial digital output from the BDLC module (BDTxD). (See [Section 23. MSCAN Controller](#) or [Section 28. Byte Data Link Controller–Digital \(BDLC–D\)](#)).

#### 1.5.17 CAN Receive Pin (CANRx)/BDLC Receive Pin (BDRxD)

If the part is configured as MC68HC08AZ32 emulator protocol, this pin is the digital input to the CAN module (CANRx). Otherwise, if the part is configured as MC68HC08AS20 emulator protocol, this pin is the serial digital input to the BDLC module (BDRxD). (See [Section 23.](#)



## General Description

[MSCAN Controller](#) or [Section 28. Byte Data Link Controller–Digital \(BDLC–D\)](#)).



**Table 1-2. External Pins Summary**

Pin Name	Function	Driver Type	Hysteresis	Reset State
PTA7–PTA0	General-Purpose I/O	Dual State	No	Input Hi-Z
PTB7/ATD7–PTB0/ATD0	General-Purpose I/O ADC Channel	Dual State	No	Input Hi-Z
PTC5–PTC0 ** PTC5 Available in 64-Pin Package Only	General-Purpose I/O	Dual State	No	Input Hi-Z
PTD7/ATD15 ** ADC Channel for MC68HC08AS20 Emulation Only	General Purpose I/O/ ADC Channel	Dual State	No	Input Hi-Z
PTD6/ATD14/TACLK ** ADC Channel for MC68HC08AS20 Emulation Only	General-Purpose I/O ADC Channel/Timer External Input Clock	Dual State	No	Input Hi-Z
PTD5/ATD13 ** ADC Channel for MC68HC08AS20 Emulation Only	General-Purpose I/O ADC Channel	Dual State	No	Input Hi-Z
PTD4/ATD12/TBCLK ** ADC Channel for MC68HC08AS20 Emulation Only TBCLK for MC68HC08AZ32 Emulation Only	General-Purpose I/O ADC Channel/Timer External Input Clock	Dual State	No	Input Hi-Z
PTD3/ATD11–PTD0/ATD8 **ADC Channels for MC68HC08AS20 Emulation Only	General-Purpose I/O ADC Channel	Dual State	No	Input Hi-Z
PTE7/SPSCK	General-Purpose I/O SPI Clock	Dual State Open Drain	Yes	Input Hi-Z
PTE6/MOSI	General-Purpose I/O SPI Data Path	Dual State Open Drain	Yes	Input Hi-Z
PTE5/MISO	General-Purpose I/O SPI Data Path	Dual State Open Drain	Yes	Input Hi-Z
PTE4/ $\overline{SS}$	General-Purpose I/O SPI Slave Select	Dual State	Yes	Input Hi-Z
PTE3/TACH1	General-Purpose I/O Timer Channel 1	Dual State	Yes	Input Hi-Z
PTE2/TACH0	General-Purpose I/O Timer Channel 0	Dual State	Yes	Input Hi-Z
PTE1/RxD	General-Purpose I/O SCI Receive Data	Dual State	Yes	Input Hi-Z
PTE0/TxD	General-Purpose I/O SCI Transmit Data	Dual State	Yes	Input Hi-Z
PTF6 **Available in 64-Pin Package Only	General-Purpose I/O	Dual State	No	Input Hi-Z

**Table 1-2. External Pins Summary (Continued)**

Pin Name	Function	Driver Type	Hysteresis	Reset State
PTF5/TBCH1–PTF4/TBCH0 ** Available in MC68HC08AZ32 Emulation Only	General-Purpose I/O/Timer B Channel	Dual State	Yes	Input Hi-Z
PTF3/TACH5 ** Timer Channel Available Only in MC68HC08AS20 Emulation	General-Purpose I/O Timer A Channel 5	Dual State	Yes	Input Hi-Z
PTF2/TACH4 ** TACH4 Available Only in MC68HC08AS20 Emulation	General-Purpose I/O Timer A Channel 4	Dual State	Yes	Input Hi-Z
PTF1/TACH3	General-Purpose I/O Timer A Channel 3	Dual State	Yes	Input Hi-Z
PTF0/TACH2	General-Purpose I/O Timer A Channel 2	Dual State	Yes	Input Hi-Z
PTG2/KBD2–PTG0/KBD0 ** Keyboard Pins Available Only in MC68HC08AZ32 Emulation	General-Purpose I/O/Keyboard Wakeup Pin	Dual State	Yes	Input Hi-Z
PTH1/KBD4 –PTH0/KBD3 **Available Only in MC68HC08AZ32 Emulation	General-Purpose I/O/Keyboard Wakeup Pin	Dual State	Yes	Input Hi-Z
$V_{DD}$	Chip Power Supply	N/A	N/A	N/A
$V_{SS}$	Chip Ground	N/A	N/A	N/A
$V_{DDA}/V_{DDAREF}$ ** $V_{DDAREF}$ Available in MC68HC08AS20 Emulation Only	Analog Power Supply	N/A	N/A	N/A
$V_{SSA}/V_{REFL}$ ** $V_{REFL}$ Available Only in MC68HC08AS20 Emulation	Analog Ground/ ADC Reference Voltage	N/A	N/A	N/A
$A_{VDD}/V_{DDAREF}$ ** Available Only in MC68HC08AZ32 Emulation	ADC Power Supply/ ADC Reference Voltage	N/A	N/A	N/A
$A_{VSS}/V_{REFL}$ ** Available Only in MC68HC08AZ32 Emulation	ADC Ground/ADC Reference Voltage	N/A	N/A	N/A
$V_{REFH}$	A/D Reference Voltage	N/A	N/A	N/A
OSC1	External Clock In	N/A	N/A	Input Hi-Z
OSC2	External Clock Out	N/A	N/A	Output
CGMXFC	PLL Loop Filter Cap	N/A	N/A	N/A
$\overline{IRQ}$	External Interrupt Request	N/A	N/A	Input Hi-Z

**Table 1-2. External Pins Summary (Continued)**

Pin Name	Function	Driver Type	Hysteresis	Reset State
$\overline{\text{RST}}$	Reset	N/A	N/A	Output Low
CANRx	CAN Serial Input	N/A	Yes	Input Hi-Z
CANTx	CAN Serial Output	Output	No	Output
BDRxD	BDLC-D Serial Input	N/A	No	Input Hi-Z
BDTxD	BDLC-D Serial Output	Output	No	Output Low

**Table 1-3. Clock Source Summary**

Module	Clock Source
ADC	CGMXCLK or Bus Clock
BDLC	CGMXCLK
CAN	CGMXCLK or CGMOUT
COP	CGMXCLK
CPU	Bus Clock
EEPROM	CGMXCLK or Bus Clock
SPI	Bus Clock/SPSCK
SCI	CGMXCLK
TIMA-4	Bus Clock or PTD6/TACLK
TIMA-6	Bus Clock or PTD6/ATD14/TACLK
TIMB	Bus Clock or PTD4/TBCLK
PIT	Bus Clock
SIM	CGMOUT and CGMXCLK
IRQ	Bus Clock
BRK	Bus Clock
LVI	Bus Clock
CGM	OSC1 and OSC2



## General Description

## Section 2. Memory Map

### 2.1 Contents

2.2	Introduction .....	59
2.3	I/O Section .....	63

### 2.2 Introduction

The CPU08 can address 64 Kbytes of memory space. The memory map, shown in **Figure 2-1**, includes:

- 32 Kbytes of FLASH EEPROM for the MC68HC08AZ32 Emulator (64-Pin QFP) or the MC68HC08AS20 Emulator (52-Pin PLCC) with Memory Extension
- 20 Kbytes of FLASH EEPROM for the MC68HC08AS20 Emulator (52-Pin PLCC)
- 1024 Bytes of RAM for the MC68HC08AZ32 Emulator (64-Pin QFP) or the MC68HC08AS20 Emulator (52-Pin PLCC) with Memory Extension
- 640 Bytes of RAM for the MC68HC08AS20 Emulator (52-Pin PLCC)
- 512 Bytes of EEPROM with Security Option
- 48 Bytes of User-Defined Vectors for the MC68HC08AZ32 Emulator (64-Pin QFP)
- 36 Bytes of User-Defined Vectors for the MC68HC08AS20 Emulator (52-Pin PLCC)
- 224 Bytes of Monitor ROM
- 128 Bytes of CAN Control and Message Buffers

**NOTE:** *The memory extension bit in the CONFIG-2 register must be set to enable 1 K of RAM memory space and 32 K of FLASH memory space in the MC68HC08AS20 emulator configuration. (See [Section 10. Configuration Register \(CONFIG-2\)](#).)*

The following definitions apply to the memory map representation of reserved and unimplemented locations.

- **Reserved** — Accessing a reserved location can have unpredictable effects on MCU operation.

- **Unimplemented** — Accessing an unimplemented location causes an illegal address reset if illegal address resets are enabled.

# Memory Map

MC68HC08AZ32 Emulator (64-Pin)		MC68HC08AS20 Emulator (52-Pin)	
\$0000	I/O REGISTERS (64 BYTES)		\$0000
↓			↓
\$003F	I/O REGISTERS, 16 BYTES TIMB AND PIT REGISTERS	UNIMPLEMENTED , 16 BYTES	\$003F
↓			↓
\$0040	RAM, 1024 BYTES	RAM, 640 BYTES	\$0040
↓			↓
\$004F	UNIMPLEMENTED, 176 BYTES		\$004F
↓			↓
\$0050	CAN CONTROL AND MESSAGE BUFFERS, 128 BYTES	UNIMPLEMENTED, 1328 BYTES	\$0050
↓			↓
\$044F	UNIMPLEMENTED, 640 BYTES		\$02CF
↓			↓
\$0450	EEPROM, 512 BYTES		\$02D0
↓			↓
\$04FF	UNIMPLEMENTED, 30,208 BYTES	UNIMPLEMENTED, 41,984 BYTES	↓
↓			↓
\$0500	FLASH, 32,256 BYTES	FLASH, 20,480 BYTES	\$07FF
↓			↓
\$057F	SIM BREAK STATUS REGISTER (SBSR)		\$0800
↓			↓
\$0580	SIM RESET STATUS REGISTER (SRSR)		\$0800
↓			↓
\$07FF	RESERVED		\$09FF
↓			↓
\$0800	SIM BREAK FLAG CONTROL REGISTER (SBFCR)		\$0A00
↓			↓
\$09FF	RESERVED		\$ADFF
↓			↓
\$0A00			\$AE00
↓			↓
\$7FFF			↓
↓			↓
\$8000			\$FDFF
↓			↓
\$FDFF			\$FE00
↓			↓
\$FE00			\$FE01
↓			↓
\$FE01			\$FE02
↓			↓
\$FE02			\$FE03
↓			↓
\$FE03			\$FE04
↓			↓
\$FE04			

**Figure 2-1. Memory Map**



	<b>MC68HC08AZ32 Emulator (64-Pin)</b>	<b>MC68HC08AS20 Emulator (52-Pin)</b>	
\$FE05	RESERVED		\$FE05
\$FE06	RESERVED		\$FE06
\$FE07	RESERVED		\$FE07
\$FE08	RESERVED		\$FE08
\$FE09	CONFIGURATION WRITE-ONCE REGISTER (CONFIG-2)		\$FE09
\$FE0A	RESERVED		\$FE0A
\$FE0B	FLASH CONTROL REGISTER (FLCR)		\$FE0B
\$FE0C	BREAK ADDRESS REGISTER HIGH (BRKH)		\$FE0C
\$FE0D	BREAK ADDRESS REGISTER LOW (BRKL)		\$FE0D
\$FE0E	BREAK STATUS AND CONTROL REGISTER (BRKSCR)		\$FE0E
\$FE0F	LVI STATUS REGISTER (LVISR)		\$FE0F
\$FE10	UNIMPLEMENTED, 12 BYTES		\$FE10
↓			↓
\$FE1B			\$FE1B
\$FE1C	EEPROM NON-VOLATILE REGISTER (EENVR)		\$FE1C
\$FE1D	EEPROM CONTROL REGISTER (EECR)		\$FE1D
\$FE1E	RESERVED		\$FE1E
\$FE1F	EEPROM ARRAY CONFIGURATION (EEACR)		\$FE1F
\$FE20	MONITOR ROM, 224 BYTES		\$FE20
↓			↓
\$FEFF			\$FEFF
\$FF00	UNIMPLEMENTED, 128 BYTES		\$FF00
↓			↓
\$FF7F			\$FF7F
\$FF80	FLASH BLOCK PROTECT REGISTER (FLBPR)		\$FF80
\$FF81	RESERVED, 79 BYTES		\$FF81
↓			↓
\$FFCF			\$FFCF
\$FFD0	VECTORS (48 BYTES)	RESERVED, 12 BYTES	\$FFD0
↓			↓
		VECTORS, 36 BYTES	\$FFDB
			\$FFDC
↓			↓
\$FFFF			\$FFFF

**Figure 2-1. Memory Map (Continued)**

## 2.3 I/O Section

Addresses \$0000–\$003F, shown in [Figure 2-2](#), contain most of the control, status, and data registers. Additional I/O registers have these addresses:

- \$FE00 (SIM break status register, SBSR)
- \$FE01 (SIM reset status register, SRSR)
- \$FE03 (SIM break flag control register, SBFCR)
- \$FE09 (configuration write-once register, CONFIG-2)
- \$FE0B (FLASH control register, FLCR)
- \$FE0C and \$FE0D (break address registers, BRKH and BRKL)
- \$FE0E (break status and control register, BRKSCR)
- \$FE0F (LVI status register, LVISR)
- \$FE1C (EEPROM non-volatile register, EENVR)
- \$FE1D (EEPROM control register, EECR)
- \$FE1F (EEPROM array configuration register, EEACR)
- \$FF80 (FLASH block protect register, FLBPR)
- \$FFFF (COP control register, COPCTL)

[Table 2-1](#) is a list of vector locations.

In **Table 2-1**, all MC68HC08AZ32 emulator specific register bits will be in **bold** face type. All MC68HC08AS20 emulator specific registers will be in *italic* face type. Those in regular type are common to both parts.

# Memory Map

Addr.	Register Name	Bit 7	6	5	4	3	2	1	Bit 0	
\$0000	Port A Data Register (PTA)	Read:	PTA7	PTA6	PTA5	PTA4	PTA3	PTA2	PTA1	PTA0
		Write:								
		Reset:	Unaffected by Reset							
\$0001	Port B Data Register (PTB)	Read:	PTB7	PTB6	PTB5	PTB4	PTB3	PTB2	PTB1	PTB0
		Write:								
		Reset:	Unaffected by Reset							
\$0002	Port C Data Register (PTC)	Read:	0	0	<b>PTC5</b>	PTC4	PTC3	PTC2	PTC1	PTC0
		Write:	R	R						
		Reset:	Unaffected by Reset							
\$0003	Port D Data Register (PTD)	Read:	<b>PTD7</b>	PTD6	PTD5	PTD4	PTD3	PTD2	PTD1	PTD0
		Write:								
		Reset:	Unaffected by Reset							
\$0004	Data Direction Register A (DDRA)	Read:	DDRA7	DDRA6	DDRA5	DDRA4	DDRA3	DDRA2	DDRA1	DDRA0
		Write:								
		Reset:	0	0	0	0	0	0	0	0
\$0005	Data Direction Register B (DDRB)	Read:	DDRB7	DDRB6	DDRB5	DDRB4	DDRB3	DDRB2	DDRB1	DDRB0
		Write:								
		Reset:	0	0	0	0	0	0	0	0
\$0006	Data Direction Register C (DDRC)	Read:	MCLKEN	0	<b>DDRC5</b>	DDRC4	DDRC3	DDRC2	DDRC1	DDRC0
		Write:		R						
		Reset:	0	0	0	0	0	0	0	0
\$0007	Data Direction Register D (DDRD)	Read:	<b>DDRD7</b>	DDRD6	DDRD5	DDRD4	DDRD3	DDRD2	DDRD1	DDRD0
		Write:								
		Reset:	0	0	0	0	0	0	0	0
\$0008	Port E Data Register (PTE)	Read:	PTE7	PTE6	PTE5	PTE4	PTE3	PTE2	PTE1	PTE0
		Write:								
		Reset:	Unaffected by Reset							
\$0009	Port F Data Register (PTF)	Read:	0	<b>PTF6</b>	<b>PTF5</b>	<b>PTF4</b>	PTF3	PTF2	PTF1	PTF0
		Write:	R							
		Reset:	Unaffected by Reset							
\$000A	Port G Data Register (PTG)	Read:	0	0	0	0	0	<b>PTG2</b>	<b>PTG1</b>	<b>PTG0</b>
		Write:	R	R	R	R	R			
		Reset:	Unaffected by Reset							

*Italic Type* = MC68HC08AS20 Specific

**Boldface Type** = MC68HC08AZ32 Specific

= Unimplemented

R = Reserved

U = Unaffected

X = Indeterminate

**Figure 2-2. Control, Status, and Data Registers (Sheet 1 of 9)**

Addr.	Register Name	Bit 7	6	5	4	3	2	1	Bit 0	
\$000B	Port H Data Register (PTH)	Read:	0	0	0	0	0	0	PTH1	PTH0
		Write:	R	R	R	R	R	R		
		Reset:	Unaffected by Reset							
\$000C	Data Direction Register E (DDRE)	Read:	DDRE7	DDRE6	DDRE5	DDRE4	DDRE3	DDRE2	DDRE1	DDRE0
		Write:								
		Reset:	0	0	0	0	0	0	0	0
\$000D	Data Direction Register F (DDRF)	Read:	0	DDRF6	DDRF5	DDRF4	DDRF3	DDRF2	DDRF1	DDRF0
		Write:	R							
		Reset:	0	0	0	0	0	0	0	0
\$000E	Data Direction Register G (DDRG)	Read:	0	0	0	0	0	DDRG2	DDRG1	DDRG0
		Write:	R	R	R	R	R			
		Reset:	0	0	0	0	0	0	0	0
\$000F	Data Direction Register H (DDRH)	Read:	0	0	0	0	0	0	DDRH1	DDRH0
		Write:	R	R	R	R	R	R		
		Reset:	0	0	0	0	0	0	0	0
\$0010	SPI Control Register (SPCR)	Read:	SPRIE	R	SPMSTR	CPOL	CPHA	SPWOM	SPE	SPTIE
		Write:								
		Reset:	0	0	1	0	1	0	0	0
\$0011	SPI Status and Control Register (SPSCR)	Read:	SPRF	ERRIE	OVRF	MODF	SPTIE	MODFEN	SPR1	SPR0
		Write:	R		R	R				
		Reset:	0	0	0	0	1	0	0	0
\$0012	SPI Data Register (SPDR)	Read:	R7	R6	R5	R4	R3	R2	R1	R0
		Write:	T7	T6	T5	T4	T3	T2	T1	T0
		Reset:	Unaffected by Reset							
\$0013	SCI Control Register 1 (SCC1)	Read:	LOOPS	ENSCI	TXINV	M	WAKE	ILTY	PEN	PTY
		Write:								
		Reset:	0	0	0	0	0	0	0	0
\$0014	SCI Control Register 2 (SCC2)	Read:	SCTIE	TCIE	SCRIE	ILIE	TE	RE	RWU	SBK
		Write:								
		Reset:	0	0	0	0	0	0	0	0
\$0015	SCI Control Register 3 (SCC3)	Read:	R8	T8	R	R	ORIE	NEIE	FEIE	PEIE
		Write:								
		Reset:	U	U	0	0	0	0	0	0

*Italic Type* = MC68HC08AS20 Specific

U = Unaffected

**Boldface Type** = MC68HC08AZ32 Specific

= Unimplemented

R = Reserved

X = Indeterminate

**Figure 2-2. Control, Status, and Data Registers (Sheet 2 of 9)**

# Memory Map

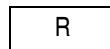
Addr.	Register Name	Bit 7	6	5	4	3	2	1	Bit 0	
\$0016	SCI Status Register 1 (SCS1)	Read:	SCTE	TC	SCRf	IDLE	OR	NF	FE	PE
		Write:								
		Reset:	1	1	0	0	0	0	0	0
\$0017	SCI Status Register 2 (SCS2)	Read:						BKF	RPF	
		Write:								
		Reset:	0	0	0	0	0	0	0	0
\$0018	SCI Data Register (SCDR)	Read:	R7	R6	R5	R4	R3	R2	R1	R0
		Write:	T7	T6	T5	T4	T3	T2	T1	T0
		Reset:	Unaffected by Reset							
\$0019	SCI Baud Rate Register (SCBR)	Read:			SCP1	SCP0	R	SCR2	SCR1	SCR0
		Write:								
		Reset:	0	0	0	0	0	0	0	0
\$001A	IRQ Status and Control Register (ISCR)	Read:	0	0	0	0	IRQF1	0	IMASK1	MODE1
		Write:	R	R	R	R	R	ACK1		
		Reset:	0	0	0	0	0	0	0	0
\$001B	Keyboard Status and Control Register (KBSCR)	Read:	0	0	0	0	KEYF	0	IMASKK	MODEK
		Write:						ACKK		
		Reset:	0	0	0	0	0	0	0	0
\$001C	PLL Control Register (PCTL)	Read:	PLLIE	PLLf	PLLON	BCS	1	1	1	1
		Write:								
		Reset:	0	0	1	0	1	1	1	1
\$001D	PLL Bandwidth Control Register (PBWC)	Read:	AUTO	LOCK	ACQ	XLD	0	0	0	0
		Write:								
		Reset:	0	0	0	0	0	0	0	0
\$001E	PLL Programming Register (PPG)	Read:	MUL7	MUL6	MUL5	MUL4	VRS7	VRS6	VRS5	VRS4
		Write:								
		Reset:	0	1	1	0	0	1	1	0
\$001F	Configuration Write-Once Register (CONFIG-1)	Read:	LVISTOP	FLASH SEC	LVIrst	LVIPWR	SSREC	COPS	STOP	COPD
		Write:								
		Reset:	0	1	1	1	0	0	0	0
\$0020	Timer A Status and Control Register (TASC)	Read:	TOF	TOIE	TSTOP	0	0	PS2	PS1	PS0
		Write:	0			TRST	R			
		Reset:	0	0	1	0	0	0	0	0

*Italic Type* = MC68HC08AS20 Specific

**Boldface Type** = MC68HC08AZ32 Specific



= Unimplemented



= Reserved

U = Unaffected

X = Indeterminate

**Figure 2-2. Control, Status, and Data Registers (Sheet 3 of 9)**

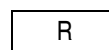
Addr.	Register Name	Bit 7	6	5	4	3	2	1	Bit 0	
\$0021	<b>Keyboard Interrupt Control Register (KBIER)</b>	Read:	0	0	0	KBIE4	KBIE3	KBIE2	KBIE1	KBIE0
		Write:								
		Reset:	0	0	0	0	0	0	0	0
\$0022	Timer A Counter Register High (TACNTH)	Read:	Bit 15	14	13	12	11	10	9	Bit 8
		Write:	R	R	R	R	R	R	R	R
		Reset:	0	0	0	0	0	0	0	0
\$0023	Timer A Counter Register Low (TACNTL)	Read:	Bit 7	6	5	4	3	2	1	Bit 0
		Write:	R	R	R	R	R	R	R	R
		Reset:	0	0	0	0	0	0	0	0
\$0024	Timer A Modulo Register High (TAMODH)	Read:	Bit 15	14	13	12	11	10	9	Bit 8
		Write:								
		Reset:	1	1	1	1	1	1	1	1
\$0025	Timer A Modulo Register Low (TAMODL)	Read:	Bit 7	6	5	4	3	2	1	Bit 0
		Write:								
		Reset:	1	1	1	1	1	1	1	1
\$0026	Timer A Channel 0 Status and Control Register (TASC0)	Read:	CH0F	CH0IE	MS0B	MS0A	ELS0B	ELS0A	TOV0	CH0MAX
		Write:	0							
		Reset:	0	0	0	0	0	0	0	0
\$0027	Timer A Channel 0 Register High (TACH0H)	Read:	Bit 15	14	13	12	11	10	9	Bit 8
		Write:								
		Reset:	Indeterminate after Reset							
\$0028	Timer A Channel 0 Register Low (TACH0L)	Read:	Bit 7	6	5	4	3	2	1	Bit 0
		Write:								
		Reset:	Indeterminate after Reset							
\$0029	Timer A Channel 1 Status and Control Register (TASC1)	Read:	CH1F	CH1IE	0	MS1A	ELS1B	ELS1A	TOV1	CH1MAX
		Write:	0		R					
		Reset:	0	0	0	0	0	0	0	0
\$002A	Timer A Channel 1 Register High (TACH1H)	Read:	Bit 15	14	13	12	11	10	9	Bit 8
		Write:								
		Reset:	Indeterminate after Reset							
\$002B	Timer A Channel 1 Register Low (TACH1L)	Read:	Bit 7	6	5	4	3	2	1	Bit 0
		Write:								
		Reset:	Indeterminate after Reset							

*Italic Type* = MC68HC08AS20 Specific

**Boldface Type** = MC68HC08AZ32 Specific



= Unimplemented



= Reserved

U = Unaffected

X = Indeterminate

**Figure 2-2. Control, Status, and Data Registers (Sheet 4 of 9)**

# Memory Map

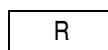
Addr.	Register Name	Bit 7	6	5	4	3	2	1	Bit 0	
\$002C	Timer A Channel 2 Status and Control Register (TASC2)	Read:	CH2F	CH2IE	MS2B	MS2A	ELS2B	ELS2A	TOV2	CH2MAX
		Write:	0							
		Reset:	0	0	0	0	0	0	0	0
\$002D	Timer A Channel 2 Register High (TACH2H)	Read:	Bit 15	14	13	12	11	10	9	Bit 8
		Write:								
		Reset:	Indeterminate after Reset							
\$002E	Timer A Channel 2 Register Low (TACH2L)	Read:	Bit 7	6	5	4	3	2	1	Bit 0
		Write:								
		Reset:	Indeterminate after Reset							
\$002F	Timer A Channel 3 Status and Control Register (TASC3)	Read:	CH3F	CH3IE	0	MS3A	ELS3B	ELS3A	TOV3	CH3MAX
		Write:	0		R					
		Reset:	0	0	0	0	0	0	0	0
\$0030	Timer A Channel 3 Register High (TACH3H)	Read:	Bit 15	14	13	12	11	10	9	Bit 8
		Write:								
		Reset:	Indeterminate after Reset							
\$0031	Timer A Channel 3 Register Low (TACH3L)	Read:	Bit 7	6	5	4	3	2	1	Bit 0
		Write:								
		Reset:	Indeterminate after Reset							
\$0032	Timer A Channel 4 Status and Control Register (TASC4)	Read:	CH4F	CH4IE	MS4B	MS4A	ELS4B	ELS4A	TOV4	CH4MAX
		Write:	0							
		Reset:	0	0	0	0	0	0	0	0
\$0033	Timer A Channel 4 Register High (TACH4H)	Read:	Bit 15	14	13	12	11	10	9	Bit 8
		Write:								
		Reset:	Indeterminate after Reset							
\$0034	Timer A Channel 4 Register Low (TACH4L)	Read:	Bit 7	6	5	4	3	2	1	Bit 0
		Write:								
		Reset:	Indeterminate after Reset							
\$0035	Timer A Channel 5 Status and Control Register (TASC5)	Read:	CH5F	CH5IE	0	MS5A	ELS5B	ELS5A	TOV5	CH5MAX
		Write:	0		R					
		Reset:	0	0	0	0	0	0	0	0
\$0036	Timer A Channel 5 Register High (TACH5H)	Read:	Bit 15	14	13	12	11	10	9	Bit 8
		Write:								
		Reset:	Indeterminate after Reset							

*Italic Type* = MC68HC08AS20 Specific

**Boldface Type** = MC68HC08AZ32 Specific



= Unimplemented



= Reserved

U = Unaffected

X = Indeterminate

**Figure 2-2. Control, Status, and Data Registers (Sheet 5 of 9)**



Addr.	Register Name	Bit 7	6	5	4	3	2	1	Bit 0	
\$0037	<i>Timer A Channel 5 Register Low (TACH5L)</i>	Read:	Bit 7	6	5	4	3	2	1	Bit 0
		Write:								
		Reset:	Indeterminate after Reset							
\$0038	Analog-to-Digital Status and Control Register (ADSCR)	Read:	COCO	AIEN	ADCO	ADCH4	ADCH3	ADCH2	ADCH1	ADCH0
		Write:	R							
		Reset:	0	0	0	1	1	1	1	1
\$0039	Analog-to-Digital Data Register (ADR)	Read:	AD7	AD6	AD5	AD4	AD3	AD2	AD1	AD0
		Write:	R	R	R	R	R	R	R	R
		Reset:	Indeterminate after Reset							
\$003A	Analog-to-Digital Input Clock Register (ADCLK)	Read:	ADIV2	ADIV1	ADIV0	ADICLK	0	0	0	0
		Write:					R	R	R	R
		Reset:	0	0	0	0	0	0	0	0
\$003B	<i>BDLC Analog and Roundtrip Delay Register (BARD)</i>	Read:	ATE	RXPOL	0	0	BO3	BO2	BO1	BO0
		Write:			R	R				
		Reset:	1	1	0	0	0	1	1	1
\$003C	<i>BDLC Control Register 1 (BCR1)</i>	Read:	IMSG	CLKS	R1	R0	0	0	IE	WCM
		Write:					R	R		
		Reset:	1	1	1	0	0	0	0	0
\$003D	<i>BDLC Control Register 2 (BCR2)</i>	Read:	ALOOP	DLOOP	RX4XE	NBFS	TEOD	TSIFR	TMIFR1	TMIFR0
		Write:								
		Reset:	1	1	0	0	0	0	0	0
\$003E	<i>BDLC State Vecto Register (BSVR)</i>	Read:	0	0	I3	I2	I1	I0	0	0
		Write:	R	R	R	R	R	R	R	R
		Reset:	0	0	0	0	0	0	0	0
\$003F	<i>BDLC Data Register (BDR)</i>	Read:	BD7	BD6	BD5	BD4	BD3	BD2	BD1	BD0
		Write:								
		Reset:	Indeterminate after Reset							
\$0040	Timer B Status and Control Register (TBSCR)	Read:	TOF	TOIE	TSTOP	0	0	PS2	PS1	PS0
		Write:	0			TRST	R			
		Reset:	0	0	1	0	0	0	0	0
\$0041	Timer B Counter Register High (TBCNTH)	Read:	Bit 15	14	13	12	11	10	9	Bit 8
		Write:	R	R	R	R	R	R	R	R
		Reset:	0	0	0	0	0	0	0	0

*Italic Type* = MC68HC08AS20 Specific

U = Unaffected

**Boldface Type** = MC68HC08AZ32 Specific

= Unimplemented

R = Reserved

X = Indeterminate

**Figure 2-2. Control, Status, and Data Registers (Sheet 6 of 9)**

# Memory Map

Addr.	Register Name	Bit 7	6	5	4	3	2	1	Bit 0	
\$0042	<b>Timer B Counter Register Low (TBCNTL)</b>	Read:	Bit 7	6	5	4	3	2	1	Bit 0
		Write:	R	R	R	R	R	R	R	R
		Reset:	0	0	0	0	0	0	0	0
\$0043	<b>Timer B Modulo Register High (TBMODH)</b>	Read:	Bit 15	14	13	12	11	10	9	Bit 8
		Write:								
		Reset:	1	1	1	1	1	1	1	1
\$0044	<b>Timer B Modulo Register Low (TBMODL)</b>	Read:	Bit 7	6	5	4	3	2	1	Bit 0
		Write:								
		Reset:	1	1	1	1	1	1	1	1
\$0045	<b>Timer B CH0 Status and Control Register (TBSC0)</b>	Read:	<b>CH0F</b>	<b>CH0IE</b>	<b>MS0B</b>	<b>MS0A</b>	<b>ELS0B</b>	<b>ELS0A</b>	<b>TOV0</b>	<b>CH0MAX</b>
		Write:	0							
		Reset:	0	0	0	0	0	0	0	0
\$0046	<b>Timer B CH0 Register High (TBCH0H)</b>	Read:	Bit 15	14	13	12	11	10	9	Bit 8
		Write:								
		Reset:	Indeterminate after Reset							
\$0047	<b>Timer B CH0 Register Low (TBCH0L)</b>	Read:	Bit 7	6	5	4	3	2	1	Bit 0
		Write:								
		Reset:	Indeterminate after Reset							
\$0048	<b>Timer B CH1 Status and Control Register (TBSC1)</b>	Read:	<b>CH1F</b>	<b>CH1IE</b>	0	<b>MS1A</b>	<b>ELS1B</b>	<b>ELS1A</b>	<b>TOV1</b>	<b>CH1MAX</b>
		Write:	0		R					
		Reset:	0	0	0	0	0	0	0	0
\$0049	<b>Timer B CH1 Register High (TBCH1H)</b>	Read:	Bit 15	14	13	12	11	10	9	Bit 8
		Write:								
		Reset:	Indeterminate after Reset							
\$004A	<b>Timer B CH1 Register Low (TBCH1L)</b>	Read:	Bit 7	6	5	4	3	2	1	Bit 0
		Write:								
		Reset:	Indeterminate after Reset							
\$004B	<b>TIM Status and Control Register (TSC)</b>	Read:	<b>TOF</b>	<b>TOIE</b>	<b>TSTOP</b>	0	0	<b>PS2</b>	<b>PS1</b>	<b>PS0</b>
		Write:	0			TRST				
		Reset:	0	0	1	0	0	0	0	0
\$004C	<b>TIM Counter Register High (TCNTH)</b>	Read:	Bit 15	14	13	12	11	10	9	Bit 8
		Write:								
		Reset:	0	0	0	0	0	0	0	0

*Italic Type* = MC68HC08AS20 Specific

U = Unaffected

**Boldface Type** = MC68HC08AZ32 Specific

= Unimplemented

R = Reserved

X = Indeterminate

**Figure 2-2. Control, Status, and Data Registers (Sheet 7 of 9)**

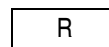
Addr.	Register Name	Bit 7	6	5	4	3	2	1	Bit 0	
\$004D	TIM Counter Register Low (TCNTL)	Read:	Bit 7	6	5	4	3	2	1	Bit 0
		Write:								
		Reset:	0	0	0	0	0	0	0	0
\$004E	TIM Modulo Register High (TMODH)	Read:	Bit 15	14	13	12	11	10	9	Bit 8
		Write:								
		Reset:	1	1	1	1	1	1	1	1
\$004F	TIM Modulo Register Low (TMODL)	Read:	Bit 7	6	5	4	3	2	1	Bit 0
		Write:								
		Reset:	1	1	1	1	1	1	1	1
\$FE00	SIM Break Status Register (SBSR)	Read:	R	R	R	R	R	SBSW	R	
		Write:						See Note		
		Reset:						0		
NOTE: Writing a logic 0 clears SBSW										
\$FE01	SIM Reset Status Register (SRSR)	Read:	POR	PIN	COP	ILOP	ILAD	0	LVI	0
		Write:								
		Reset:	1	X	0	0	0	0	X	0
\$FE03	SIM Break Flag Control Register (SBFCR)	Read:	BCFE	R	R	R	R	R	R	R
		Write:								
		Reset:	0						0	
\$FE09	Configuration Write-Once Register (CONFIG-2)	Read:	0	0	0	MSCAND	0	0	MEMEXT	AZ32
		Write:								
		Reset:	0	0	0	1	0	0	1	0
\$FE0B	FLASH Control Register	Read:	FDIV1	FDIV0	BLKI	BLKO	HVEN	VERF	ERASE	PGM
		Write:								
		Reset:	0	0	0	0	0	0	0	0
\$FE0C	Break Address Register High (BRKH)	Read:	Bit 15	14	13	12	11	10	9	Bit 8
		Write:								
		Reset:	0	0	0	0	0	0	0	0
\$FE0D	Break Address Register Low (BRKL)	Read:	Bit 7	6	5	4	3	2	1	Bit 0
		Write:								
		Reset:	0	0	0	0	0	0	0	0
\$FE0E	Break Status and Control Register (BRKSCR)	Read:	BRKE	BRKA	0	0	0	0	0	0
		Write:								
		Reset:	0	0	0	0	0	0	0	0

*Italic Type* = MC68HC08AS20 Specific

**Boldface Type** = MC68HC08AZ32 Specific



= Unimplemented



= Reserved

U = Unaffected

X = Indeterminate

**Figure 2-2. Control, Status, and Data Registers (Sheet 8 of 9)**

# Memory Map

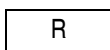
Addr.	Register Name	Bit 7	6	5	4	3	2	1	Bit 0	
\$FE0F	LVI Status Register (LVISR)	Read:	LVIOUT	0	0	0	0	0	0	
		Write:								
		Reset:	0	0	0	0	0	0	0	
\$FE1C	EEPROM Nonvolatile Register (EENVR)	Read:	EERA	CON2	CON1	CON0	EEBP3	EEBP2	EEBP1	EEBP0
		Write:								
		Reset:	Programmed Value or 1 in the Erased State							
\$FE1D	EEPROM Control Register (EECR)	Read:	EEBCLK	0	EEOFF	EERAS1	EERAS0	EELAT	0	EEPGM
		Write:				1	0			
		Reset:	0	0	0	0	0	0	0	0
\$FE1E	Reserved	Reserved								
\$FE1F	EEPROM Array Control Register (EEACR)	Read:	EERA	CON2	CON1	CON0	EEBP3	EEBP2	EEBP1	EEBP0
		Write:								
		Reset:	EENVR							
\$FF80	FLASH Block Protect Register (FLBPR)	Read:	0	0	0	0	BPR3	BPR2	BPR1	BPR0
		Write:								
		Reset:	0	0	0	0	0	0	0	0
\$FFFF	COP Control Register (COPCTL)	Read:	LOW BYTE OF RESET VECTOR							
		Write:	WRITING TO \$FFFF CLEARS COP COUNTER							
		Reset:	Unaffected by Reset							

*Italic Type* = MC68HC08AS20 Specific

**Boldface Type** = MC68HC08AZ32 Specific



= Unimplemented



= Reserved

U = Unaffected

X = Indeterminate

**Figure 2-2. Control, Status, and Data Registers (Sheet 9 of 9)**

Table 2-1. Vector Addresses

Address	MC68HC08AZ32 Emulation	MC68HC08AS20 Emulation
\$FFD0	ADC Vector (High)	
\$FFD1	ADC Vector (Low)	
\$FFD2	Keyboard Vector (High)	
\$FFD3	Keyboard Vector (Low)	
\$FFD4	SCI Transmit Vector (High)	
\$FFD5	SCI Transmit Vector (Low)	
\$FFD6	SCI Receive Vector (High)	
\$FFD7	SCI Receive Vector (Low)	
\$FFD8	SCI Error Vector (High)	
\$FFD9	SCI Error Vector (Low)	
\$FFDA	CAN Transmit Vector (High)	
\$FFDB	CAN Transmit Vector (Low)	
\$FFDC	CAN Receive Vector (High)	<i>BDLC Vector (High)</i>
\$FFDD	CAN Receive Vector (Low)	<i>BDLC Vector (Low)</i>
\$FFDE	CAN Error Vector (High)	<i>ADC Vector (High)</i>
\$FFDF	CAN Error Vector (Low)	<i>ADC Vector (Low)</i>
\$FFE0	CAN Wakeup Vector (High)	<i>SCI Transmit Vector (High)</i>
\$FFE1	CAN Wakeup Vector (Low)	<i>SCI Transmit Vector (Low)</i>
\$FFE2	SPI Transmit Vector (High)	<i>SCI Receive Vector (High)</i>
\$FFE3	SPI Transmit Vector (Low)	<i>SCI Receive Vector (Low)</i>
\$FFE4	SPI Receive Vector (High)	<i>SCI Error Vector (High)</i>
\$FFE5	SPI Receive Vector (Low)	<i>SCI Error Vector (Low)</i>
\$FFE6	TIMB Overflow Vector (High)	<i>SPI Transmit Vector (High)</i>
\$FFE7	TIMB Overflow Vector (Low)	<i>SPI Transmit Vector (Low)</i>
\$FFE8	TIMB CH1 Vector (High)	<i>SPI Receive Vector (High)</i>
\$FFE9	TIMB CH1 Vector (Low)	<i>SPI Receive Vector (Low)</i>
\$FFEA	TIMB CH0 Vector (High)	<i>TIM Overflow Vector (High)</i>
\$FFEB	TIMB CH0 Vector (Low)	<i>TIM Overflow Vector (Low)</i>
\$FFEC	TIMA Overflow Vector (High)	<i>TIM Channel 5 Vector (High)</i>
\$FFED	TIMA Overflow Vector (Low)	<i>TIM Channel 5 Vector (Low)</i>
\$FFEE	TIMA CH3 Vector (High)	<i>TIM Channel 4 Vector (High)</i>
\$FFEF	TIMA CH3 Vector (Low)	<i>TIM Channel 4 Vector (Low)</i>
\$FFF0	TIMA CH2 Vector (High)	<i>TIM Channel 3 Vector (High)</i>
\$FFF1	TIMA CH2 Vector (Low)	<i>TIM Channel 3 Vector (Low)</i>
\$FFF2	TIMA CH1 Vector (High)	<i>TIM Channel 2 Vector (High)</i>
\$FFF3	TIMA CH1 Vector (Low)	<i>TIM Channel 2 Vector (Low)</i>

Low ↑  
 Priority ↓

**Table 2-1. Vector Addresses (Continued)**

	Address	MC68HC08AZ32 Emulation	MC68HC08AS20 Emulation	
Low	\$FFF4	<b>TIMA CH0 Vector (High)</b>	<i>TIM Channel 1 Vector (High)</i>	
	\$FFF5	<b>TIMA CH0 Vector (Low)</b>	<i>TIM Channel 1 Vector (Low)</i>	
Priority	\$FFF6	<b>PIT Vector (High)</b>	<i>TIM Channel 0 Vector (High)</i>	
	\$FFF7	<b>PIT Vector (Low)</b>	<i>TIM Channel 0 Vector (Low)</i>	
	\$FFF8	PLL Vector (High)		
	\$FFF9	PLL Vector (Low)		
	\$FFFA	IRQ1 Vector (High)		
	\$FFFFB	IRQ1 Vector (Low)		
	\$FFFC	SWI Vector (High)		
	\$FFFD	SWI Vector (Low)		
	High	\$FFFE	Reset Vector (High)	
		\$FFFF	Reset Vector (Low)	

## Section 3. Random-Access Memory (RAM)

### 3.1 Contents

3.2	Introduction . . . . .	75
3.3	Functional Description . . . . .	75

### 3.2 Introduction

This section describes the 1024 bytes of random-access memory (RAM).

### 3.3 Functional Description

Addresses \$0050 through \$044F are RAM locations. The location of the stack RAM is programmable. The 16-bit stack pointer allows the stack to be anywhere in the 1024-byte memory space.

**NOTE:** *For correct operation, the stack pointer must point only to RAM locations.*

Within page zero are 176 bytes of RAM. Because the location of the stack RAM is programmable, all page zero RAM locations can be used for input/output (I/O) control and user data or code. When the stack pointer is moved from its reset location at \$00FF, direct addressing mode instructions can access all page zero RAM locations efficiently. Page zero RAM, therefore, provides ideal locations for frequently accessed global variables.

Before processing an interrupt, the CPU uses five bytes of the stack to save the contents of the CPU registers.

## Random-Access Memory (RAM)

**NOTE:** *For M68HC05, M6805, and M146805 compatibility, the H register is not stacked.*

During a subroutine call, the CPU uses two bytes of the stack to store the return address. The stack pointer decrements during pushes and increments during pulls.

**NOTE:** *Be careful when using nested subroutines. The CPU could overwrite data in the RAM during a subroutine or during the interrupt stacking operation.*



## Section 4. FLASH Memory

### 4.1 Contents

4.2	Introduction . . . . .	77
4.3	Functional Description . . . . .	77
4.4	FLASH Control Register . . . . .	78
4.5	Charge Pump Frequency Control . . . . .	80
4.6	FLASH Erase Operation . . . . .	80
4.7	FLASH Program/Verify Operation . . . . .	81
4.8	Block Protection . . . . .	82
4.9	FLASH Block Protect Register . . . . .	83

### 4.2 Introduction

This section describes the operation of the embedded FLASH memory. This memory can be read, programmed, and erased from a single external supply through the use of on-board charge pumps for program and erase.

### 4.3 Functional Description

The FLASH memory is an array of 32,256 bytes with an additional 48 bytes of user vectors and one byte of block protection. An erased bit reads as a logic 0 and a programmed bit reads as a logic 1. Program and erase operations are facilitated through control bits in a memory mapped

register. Details for these operations appear later in this section. The address ranges for the user memory and vectors are:

- \$8000–\$FDFF
- \$FF80 (block protect register)
- \$FFD0–\$FFFF (These locations are reserved for user-defined interrupt and reset vectors.)

Programming tools are available from Freescale. Contact your local Freescale representative for more information.

**NOTE:** *A security feature prevents viewing of the FLASH contents.<sup>1</sup>*

## 4.4 FLASH Control Register

The FLASH control register controls FLASH program, erase, and verify operations.

Address: \$FE0B

	Bit 7	6	5	4	3	2	1	Bit 0
Read:	FDIV1	FDIV0	BLK1	BLK0	HVEN	VERF	ERASE	PGM
Write:								
Reset:	0	0	0	0	0	0	0	0

**Figure 4-1. FLASH Control Register (FLCR)**

**FDIV1** — Frequency Divide Control Bit

This read/write bit together with FDIV0 selects the factor by which the charge pump clock is divided from the system clock. See [4.5 Charge Pump Frequency Control](#).

**FDIV0** — Frequency Divide Control Bit

This read/write bit together with FDIV1 selects the factor by which the charge pump clock is divided from the system clock. See [4.5 Charge Pump Frequency Control](#).

1. No security feature is absolutely secure. However, Freescale's strategy is to make reading or copying the FLASH difficult for unauthorized users.

#### BLK1— Block Erase Control Bit

This read/write bit together with BLK0 allows erasing of blocks of varying size. See [4.6 FLASH Erase Operation](#) for a description of available block sizes.

#### BLK0 — Block Erase Control Bit

This read/write bit together with BLK1 allows erasing of blocks of varying size. See [4.6 FLASH Erase Operation](#) for a description of available block sizes.

#### HVEN — High-Voltage Enable Bit

This read/write bit enables high voltage from the charge pump to the memory for either program or erase operation. It can only be set if either PGM or ERASE is high and the sequence for erase or program/verify is followed.

- 1 = High voltage enabled to array and charge pump on
- 0 = High voltage disabled to array and charge pump off

#### VERF — Verify Control Bit

This read/write bit configures the memory for verify operation. It cannot be set if the HVEN bit is high, and if it is high when HVEN is set, it will automatically return to 0.

- 1 = Verify operation selected
- 0 = Verify operation unselected

#### ERASE — Erase Control Bit

This read/write bit configures the memory for erase operation. It is interlocked with the PGM bit such that both bits cannot be equal to 1 or set to 1 at the same time.

- 1 = Erase operation selected
- 0 = Erase operation unselected

#### PGM — Program Control Bit

This read/write bit configures the memory for program operation. It is interlocked with the ERASE bit such that both bits cannot be equal to 1 or set to 1 at the same time.

- 1 = Program operation selected
- 0 = Program operation unselected

## 4.5 Charge Pump Frequency Control

The internal charge pump is designed to operate at greatest efficiency at a frequency of 2 MHz. [Table 4-1](#) shows how the FDIV bits are used to select a charge pump frequency and the recommended bus frequency ranges for each configuration. Program and erase operations cannot be performed if the pump clock frequency is below 2 MHz.

**Table 4-1. Charge Pump Clock Frequency**

FDIV1	FDIV0	Pump Clock Frequency	Bus Frequency
0	0	Bus Frequency ÷ 1	2 MHz ± 10%
0	1	Bus Frequency ÷ 2	4 MHz ± 10%
1	0	Bus Frequency ÷ 2	4 MHz ± 10%
1	1	Bus Frequency ÷ 4	8 MHz ± 10%

## 4.6 FLASH Erase Operation

Use the following procedure to erase a block of FLASH memory:

1. Set the ERASE bit and the BLK0 and BLK1 bits in the FLASH control register. See [Table 4-2](#) for block sizes.
2. Read from the block protect register: address \$FF80.
3. Write to any FLASH address with any data within the block address range desired.
4. Set the HVEN bit.
5. Wait for a time,  $t_{Erase}$ .
6. Clear the HVEN bit.
7. Wait for a time,  $t_{Kill}$  for the high voltages to dissipate.
8. Clear the ERASE bit.
9. After time,  $t_{HVD}$ , the memory can be accessed in read mode again.

**NOTE:** *While these operations must be performed in the order shown, other unrelated operations may occur between the steps.*

**Table 4-2** shows the various block sizes which can be erased in one erase operation.

**Table 4-2. Erase Block Sizes**

BLK1	BLK0	Block Size, Addresses Cared
0	0	Full Array: 32 Kbytes (A15)
0	1	One-Half Array: 16 Kbytes (A15 and A14)
1	0	Eight Rows: 512 Bytes (A15–A9)
1	1	Single Row: 64 Bytes (A15–A6)

In step 2 of the erase operation, the cared addresses are latched and used to determine the location of the block to be erased. For the full array, the only requirement is that A15 be high. Writing to any address in the range \$8000 to \$FFFF will enable the full-array erase.

## 4.7 FLASH Program/Verify Operation

Programming of the FLASH memory is done on a page basis. A page consists of eight consecutive bytes starting from address \$XXX0 or \$XXX8. The purpose of the verify mode is to ensure that data has been programmed with sufficient margin for long-term data retention. During verify, the control gates of the selected memory bits are held at a slightly negative voltage by an internal charge pump. Reading the data is the same as for ordinary read mode except that a built-in counter stretches the data access for an additional eight cycles to allow sensing of the lower cell current. A verify can only follow a program operation. To program and verify the FLASH memory:

1. Set the PGM bit. This configures the memory for program operation and enables the latching of address and data for programming.
2. Read from the block protect register.
3. Write data to the eight bytes of the page being programmed. This requires eight separate write operations.
4. Set the HVEN bit.
5. Wait for time,  $t_{\text{PROG}}$ .

6. Clear the HVEN bit.
7. Wait for time,  $t_{HVTV}$ .
8. Set the VERF bit.
9. Wait for time,  $t_{VTP}$ .
10. Clear the PGM bit.
11. Wait for time,  $t_{HVD}$ .
12. Read back data in verify mode. This is done in eight separate read operations which are each stretched by eight cycles.
13. Clear the VERF bit.

**NOTE:** *While these operations must be performed in the order shown, other unrelated operations may occur between the steps.*

This program/verify sequence is repeated throughout the memory until all data is programmed. For minimum overall programming time and least program disturb effect, the sequence should be part of an intelligent operation which iterates per page (See [4.6 FLASH Erase Operation](#)).

## 4.8 Block Protection

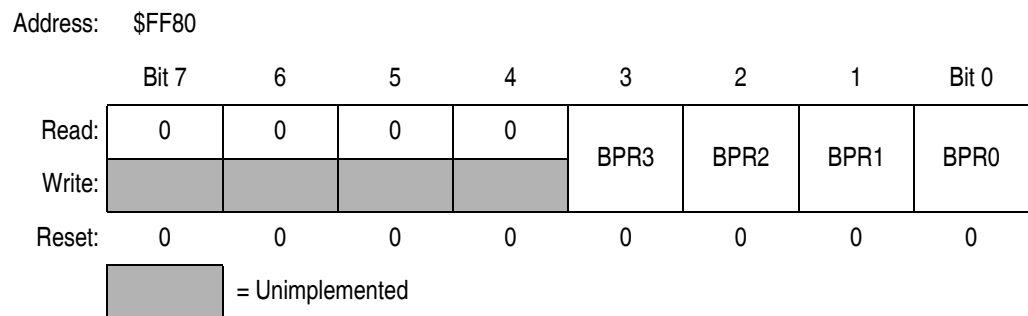
Due to the ability of the on-board charge pump to erase and program the FLASH memory in the target application, provision is made for protecting blocks of memory from unintentional erase or program operations due to system malfunction. This protection is done by reserving a location in the memory for block protect information and requiring that this location be read from to enable setting of the HVEN bit. When the block protect register is read, its contents are latched by the FLASH control logic. If the address range for an erase or program operation includes a protected block, the PGM or ERASE bit is cleared which prevents the HVEN bit in the FLASH control register from being set so that no high voltage is allowed in the array.

When the block protect register is erased (all 0s), the entire memory is accessible for program and erase. When bits within the register are programmed, they lock blocks of memory address ranges as shown in [4.9 FLASH Block Protect Register](#). The block protect register itself can

be erased or programmed only with an external voltage  $V_{DD} + V_{HI}$  present on the  $\overline{IRQ}$  pin. This voltage also allows entry from reset into the monitor mode.

## 4.9 FLASH Block Protect Register

The block protect register is implemented as a byte within the FLASH memory. Each bit, when programmed, protects a range of addresses in the FLASH.



**Figure 4-2. FLASH Block Protect Register (FLBPR)**

### BPR3 — Block Protect Register Bit 3

This bit protects the memory contents in the address range \$C000 to \$FFFF.

- 1 = Address range protected from erase or program
- 0 = Address range open to erase or program

### BPR2 — Block Protect Register Bit 2

This bit protects the memory contents in the address range \$A000 to \$FFFF.

- 1 = Address range protected from erase or program
- 0 = Address range open to erase or program

### BPR1 — Block Protect Register Bit 1

This bit protects the memory contents in the address range \$9000 to \$FFFF.

- 1 = Address range protected from erase or program
- 0 = Address range open to erase or program

**BPR0 — Block Protect Register Bit 0**

This bit protects the memory contents in the address range \$8000 to \$FFFF.

1 = Address range protected from erase or program

0 = Address range open to erase or program

By programming the block protect bits, a portion of the memory will be locked so that no further erase or program operations may be performed. Programming more than one bit at a time is redundant. If both bit 3 and bit 2 are set, for instance, the address range \$A000 through \$FFFF is locked. If all bits are erased, then all of the memory is available for erase and program. The presence of a voltage  $V_{DD} + V_{HI}$  on the  $\overline{IRQ}$  pin will bypass the block protection so that all of the memory, including the block protect register, is open for program and erase operations.



## Section 5. Electrically Erasable Programmable ROM (EEPROM)

### 5.1 Contents

5.2	Introduction . . . . .	85
5.3	Features . . . . .	86
5.4	Functional Description . . . . .	86
5.4.1	EEPROM Programming . . . . .	86
5.4.2	EEPROM Erasing . . . . .	88
5.4.3	EEPROM Block Protection . . . . .	90
5.4.4	EEPROM Redundant Mode . . . . .	90
5.4.5	MCU Configuration . . . . .	91
5.4.6	MC68HC908AT32 EEPROM Security . . . . .	91
5.4.7	EEPROM Control Register . . . . .	92
5.4.8	EEPROM Nonvolatile Register and EEPROM Array Configuration Register . . . . .	94
5.4.9	Low-Power Modes . . . . .	95
5.4.9.1	Wait Mode . . . . .	95
5.4.9.2	Stop Mode . . . . .	95

### 5.2 Introduction

This section describes the electrically erasable programmable read-only memory (EEPROM).

## 5.3 Features

EEPROM features include:

- Modular Architecture Expandable in 128 Bytes
- Byte, Block, or Bulk Erasable
- Nonvolatile Redundant Array Option
- Nonvolatile Block Protection Option
- Nonvolatile MCU Configuration Bits
- On-Chip Charge Pump for Programming/Erasing
- Security Option

## 5.4 Functional Description

The 512 bytes of EEPROM can be programmed or erased without an external voltage supply. The EEPROM has a lifetime of 10,000 write-erase cycles in the nonredundant mode. Reliability (data retention) is further extended if the redundancy option is selected. EEPROM cells are protected with a nonvolatile block protection option. These options are stored in the EEPROM nonvolatile register (EENVR) and are loaded into the EEPROM array configuration register after reset (EEACR) or a read of EENVR. Hardware interlocks are provided to protect stored data corruption from accidental programming/erasing.

### 5.4.1 EEPROM Programming

The unprogrammed state is a logic 1. Programming changes the state to a logic 0. Only valid EEPROM bytes in the non-protected blocks and EENVR can be programmed. When the array is configured in the redundant mode, programming the first 256 bytes also will program the last 256 bytes with the same data. Programming the EEPROM in the nonredundant mode is recommended. Program the data to both locations before entering redundant mode.

Following this procedure to program a byte of EEPROM:

1. Clear EERAS1 and EERAS0 and set EELAT in the EECTL. Set value of  $t_{EEPGM}$ . (See note A and B.)
2. Write the desired data to any user EEPROM address.
3. Set the EEPGM bit. (See note C.)
4. Wait for a time,  $t_{EEPGM}$ , to program the byte.
5. Clear EEPGM bit.
6. Wait for the programming voltage time,  $t_{EEFPV}$ , to fall.
7. Clear EELAT bits. (See note D.)
8. Repeat steps 1 to 7 for more EEPROM programming.

NOTES:

- A. EERAS1 and EERAS0 must be cleared for programming. Otherwise, the part will be in erase mode.
- B. Setting EELAT bit configures the address and data buses to latch data for programming the array. Only data with valid EEPROM address will be latched. If another consecutive valid EEPROM write occurs, this address and data will override the previous address and data. Any attempts to read other EEPROM data will read the latched data. If EELAT is set, other writes to the EECR will be allowed after a valid EEPROM write.
- C. To ensure proper programming sequence, the EEPGM bit cannot be set if the EELAT bit is cleared and a non-EEPROM write has occurred. When EEPGM is set, the onboard charge pump generates the program voltage and applies it to the user EEPROM array. When the EEPGM bit is cleared, the program voltage is removed from the array and the internal charge pump is turned off.
- D. Any attempt to clear both EEPGM and EELAT bits with a single instruction will only clear EEPGM. This is to allow time for removal of high voltage from the EEPROM array.

## 5.4.2 EEPROM Erasing

The unprogrammed state is a logic 1. Only the valid EEPROM bytes in the nonprotected blocks and EENVr can be erased. When the array is configured in the redundant mode, erasing the first 256 bytes also will erase the last 256 bytes.

Using this procedure erases EEPROM:

1. Clear/set EERAS1 and EERAS0 to select byte/block/bulk erase, and set EELAT in EECTL. Set value of  $t_{EEBYT}/t_{EEBLOCK}/t_{EEBULK}$ . (See note A.)
2. Write any data to the desired address for byte erase, to any address in the desired block for block erase, or to any array address for bulk erase.
3. Set the EEPGM bit. (See note B.)
4. Wait for a time,  $t_{EEPGM}$ , to program the byte.
5. Clear EEPGM bit.
6. Wait for the erasing voltage time,  $t_{EEFPV}$ , to fall.
7. Clear EELAT bits. (See note C.)
8. Repeat steps 1 to 7 for more EEPROM byte/block erasing.

EEBPx bit must be cleared to erase EEPROM data in the corresponding block. If any EEBPx is set, the corresponding block can not be erased and bulk erase mode does not apply.

### NOTES:

- a. Setting EELAT bit configures the address and data buses to latch data for erasing the array. Only valid EEPROM addresses with their data will be latched. If another consecutive valid EEPROM write occurs, this address and data will override the previous address and data. In block erase mode, any EEPROM address in the block may be used in step 2. All locations within this block will be erased. In bulk erase mode, any EEPROM address may be used to erase the whole EEPROM. EENVr is not affected with block or bulk

erase. Any attempts to read other EEPROM data will read the latched data. If EELAT is set, other writes to the EECR will be allowed after a valid EEPROM write.

- B. The EEPGM bit cannot be set if the EELAT bit is cleared and a non-EEPROM write has occurred. This is to ensure proper erasing sequence. Once EEPGM is set, the type of erase mode cannot be modified. If EEPGM is set, the onboard charge pump generates the erase voltage and applies it to the user EEPROM array. When the EEPGM bit is cleared, the erase voltage is removed from the array and the internal charge pump is turned off.
- C. Any attempt to clear both EEPGM and EELAT bits with a single instruction will only clear EEPGM. This is to allow time for removal of high voltage from the EEPROM array.

In general, all bits should be erased before being programmed. However, if program/erase cycling is of concern, minimize bit cycling in each EEPROM byte. If any bit in a byte requires change from a 0 to a 1, the byte needs be erased before programming. [Table 5-1](#) summarizes the conditions for erasing before programming.

**Table 5-1. EEPROM Program/Erase Cycling Reduction**

EEPROM Data To Be Programmed	EEPROM Data Before Programming	Erase Before Programming?
0	0	No
0	1	No
1	0	Yes
1	1	No

## 5.4.3 EEPROM Block Protection

The 512 bytes of EEPROM are divided into four 128-byte blocks. Each of these blocks can be separately protected by EEBPx bit. Any attempt to program or erase memory locations within the protected block will not allow the program/erase voltage to be applied to the array. [Table 5-2](#) shows the address ranges within the blocks.

**Table 5-2. EEPROM Array Address Blocks**

Block Number (EEBPx)	Address Range
EEBP0	\$0800–\$087F
EEBP1	\$0880–\$08FF
EEBP2	\$0900–\$097F
EEBP3	\$0980–\$09FF

If EEBPx bit is set, that corresponding address block is protected. These bits are effective after a reset or a read to EENVR register. The block protect configuration can be modified by erasing/programming the corresponding bits in the EENVR register and then reading the EENVR register.

In redundant mode, EEBP3 and EEBP2 will have no meaning.

## 5.4.4 EEPROM Redundant Mode

To extend the EEPROM data retention, the array can be placed in redundant mode. In this mode, the first 256 bytes of user EEPROM array are mapped to the last 256 bytes. Reading, programming and erasing of the first 256 EEPROM bytes will physically affect two bytes of EEPROM. Addressing the last 256 bytes will not be recognized. Block protection still applies but EEBP3 and EEBP2 are meaningless.

**NOTE:** *Programming the EEPROM in nonredundant mode and programming the data to its corresponding location before entering redundant mode is recommended.*

The EEPROM nonvolatile register (EENVR) contains configurations concerning block protection and redundancy. EENVR is physically

located on the bottom of the EEPROM array. The contents are nonvolatile and are not modified by reset. On reset, this special register loads the EEPROM configuration into a corresponding volatile EEPROM array configuration register (EEACR). Thereafter, all reads to the EENVR will reload EEACR.

The EEPROM configuration can be changed by programming/erasing the EENVR like a normal EEPROM byte. The new array configuration will take affect with a system reset or a read of the EENVR.

#### 5.4.5 MCU Configuration

The EEPROM nonvolatile register (EENVR) also contains general-purpose bits which can be used to enable/disable functions within the MCU which, for safety reasons, need to be controlled from nonvolatile memory. On reset, this special register loads the MCU configuration into the volatile EEPROM array configuration register (EEACR). Thereafter, all reads to the EENVR will reload EEACR.

The MCU configuration can be changed by programming/erasing the EENVR like a normal EEPROM byte. The new array configuration will take affect with a system reset or a read of the EENVR.

#### 5.4.6 MC68HC908AT32 EEPROM Security

The MC68HC908AT32 has a special security option which prevents program/erase access to memory locations \$08F0 to \$08FF. This security function is enabled by programming the CON0 bit in the EENVR to 0.

**NOTE:** *Once armed, the security is permanently enabled. As a consequence, all functions in the EENVR will remain in the state they were in immediately before the security was enabled.*


**Once the security is armed bulk and block erase modes are disabled for all EEPROM locations.** Byte erasing can be used for all locations except \$08F0 to \$08FF. These protected locations can be read as normal.

## 5.4.7 EEPROM Control Register

This read/write register controls programming/erasing of the array.

Address: \$FE1D

	Bit 7	6	5	4	3	2	1	Bit 0
Read:	EEBCLK	0	EEOFF	EERAS1	EERAS0	EELAT	0	EEPGM
Write:				1	0			
Reset:	0	0	0	0	0	0	0	0

 = Unimplemented

**Figure 5-1. EEPROM Control Register (EECR)**

### EEBCLK — EEPROM Bus Clock Enable

This read/write bit determines which clock will be used to drive the internal charge pump for programming/erasing. Reset clears this bit.

1 = Bus clock drives charge pump

0 = Internal RC oscillator drives charge pump

**NOTE:** *Using the internal RC oscillator for applications in the 3 to 5 V range is recommended.*

### EEOFF — EEPROM Power Down

This read/write bit disables the EEPROM module for lower power consumption. Any attempts to access the array will give unpredictable results. Reset clears this bit.

1 = Disable EEPROM array

0 = Enable EEPROM array

**NOTE:** *The EEPROM requires a recovery time,  $t_{EEOFF}$ , to stabilize after clearing the EEOFF bit.*



### EERAS1 and EERAS0 — Erase Bits

These read/write bits set the erase modes. Reset clears these bits.

**Table 5-3. EEPROM Program/Erase Mode Select**

EERP <sub>x</sub>	EERAS1	EERA0	MODE
0	0	0	Byte Program
0	0	1	Byte Erase
0	1	0	Block Erase
0	1	1	Bulk Erase
1	X	X	No Erase/Program

X = don't care

### EELAT — EEPROM Latch Control

This read/write bit latches the address and data buses for programming the EEPROM array. EELAT cannot be cleared if EEPGM is still set. Reset clears this bit.

1 = Buses configured for EEPROM programming

0 = Buses configured for normal read operation

### EEPGM — EEPROM Program/Erase Enable

This read/write bit enables the internal charge pump and applies the programming/erasing voltage to the EEPROM array if the EELAT bit is set and a write to a valid EEPROM location has occurred. Reset clears the EEPGM bit.

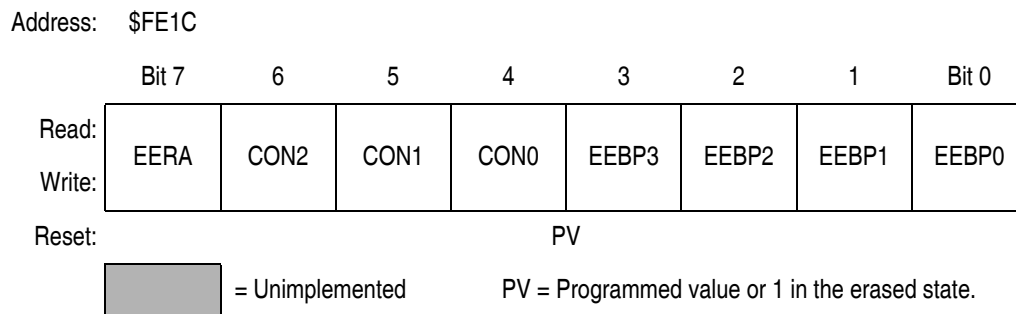
1 = EEPROM programming/erasing power switched on

0 = EEPROM programming/erasing power switched off

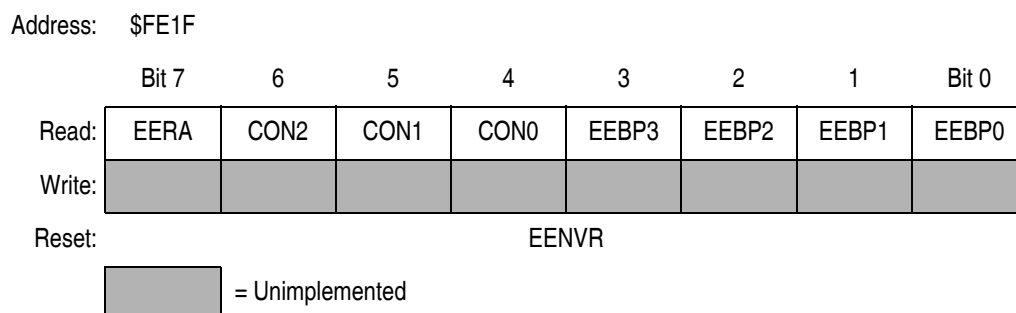
**NOTE:** *Writing logic 0s to both the EELAT and EEPGM bits with a single instruction will clear EEPGM only to allow time for the removal of high voltage.*

## 5.4.8 EEPROM Nonvolatile Register and EEPROM Array Configuration Register

The EEPROM nonvolatile register (EENVR) and array configuration register (EEACR) are shown in [Figure 5-3](#) and [Figure 5-2](#).



**Figure 5-2. EEPROM Nonvolatile Register (EENVR)**



**Figure 5-3. EEPROM Array Control Register (EEACR)**

### EERA — EEPROM Redundant Array

This programmable/erasable/read bit in EENVR and read-only bit in EEACR configures the array in redundant mode. Reset loads EERA from EENVR to EEACR.

- 1 = EEPROM array is in redundant mode configuration
- 0 = EEPROM array is in normal mode configuration

### CONx — MCU Configuration Bits

These read/write bits can be used to enable/disable functions within the MCU. Reset loads CONx from EENVR to EEACR.

CON2 — Unused

CON1 — Unused

**CON0 — EEPROM Security**

1 = EEPROM security disabled

0 = EEPROM security enabled

**EEBP3–EEBP0 — EEPROM Block Protection Bits**

These read/write bits select blocks of EEPROM array from being programmed or erased. Reset loads EEBP[3:0] from EENVR to EEACR.

1 = EEPROM array block is protected

0 = EEPROM array block is unprotected

### 5.4.9 Low-Power Modes

The WAIT and STOP instructions can put the MCU in low-power standby modes.

#### 5.4.9.1 Wait Mode

The WAIT instruction does not affect the EEPROM. It is possible to program the EEPROM and put the MCU in wait mode. However, if the EEPROM is inactive, power can be reduced by setting the EEOFF bit before executing the WAIT instruction.

#### 5.4.9.2 Stop Mode

The STOP instruction reduces the EEPROM power consumption to a minimum. The STOP instruction should not be executed while the high voltage is turned on (EEPGM = 1).

If stop mode is entered while program/erase is in progress, high voltage will be automatically turned off. However, the EEPGM bit will remain set. When stop mode is terminated, and if EEPGM is still set, the high voltage will be automatically turned back on. Program/erase time will need to be extended if program/erase is interrupted by entering stop mode.

The module requires a recovery time,  $t_{EESTOP}$ , to stabilize after leaving stop mode. Attempts to access the array during the recovery time will result in unpredictable behavior.



# Electrically Erasable Programmable ROM

## Section 6. Central Processor Unit (CPU)

### 6.1 Contents

6.2	Introduction . . . . .	97
6.3	Features . . . . .	98
6.4	CPU Registers . . . . .	98
6.4.1	Accumulator . . . . .	99
6.4.2	Index Register . . . . .	99
6.4.3	Stack Pointer . . . . .	100
6.4.4	Program Counter . . . . .	101
6.4.5	Condition Code Register . . . . .	102
6.5	Arithmetic/Logic Unit (ALU) . . . . .	104
6.6	Low-Power Modes . . . . .	104
6.6.1	Wait Mode . . . . .	104
6.6.2	Stop Mode . . . . .	104
6.7	CPU During Break Interrupts . . . . .	105
6.8	Instruction Set Summary . . . . .	106
6.9	Opcode Map . . . . .	113

### 6.2 Introduction

The M68HC08 CPU is an enhanced and fully object-code-compatible version of the M68HC05 CPU. The *CPU08 Reference Manual* (Freescale document number CPU08RM/AD) contains a description of the CPU instruction set, addressing modes, and architecture.

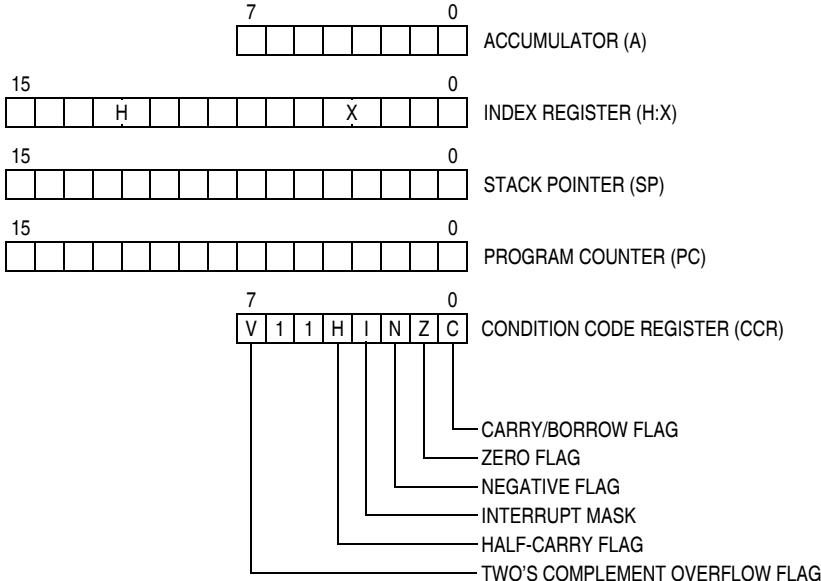
## 6.3 Features

Features of the CPU include:

- Object Code Fully Upward-Compatible with M68HC05 Family
- 16-Bit Stack Pointer with Stack Manipulation Instructions
- 16-Bit Index Register with X-Register Manipulation Instructions
- 8-MHz CPU Internal Bus Frequency
- 64-Kbyte Program/Data Memory Space
- 16 Addressing Modes
- Memory-to-Memory Data Moves without Using Accumulator
- Fast 8-Bit by 8-Bit Multiply and 16-Bit by 8-Bit Divide Instructions
- Enhanced Binary-Coded Decimal (BCD) Data Handling
- Modular Architecture with Expandable Internal Bus Definition for Extension of Addressing Range beyond 64 Kbytes
- Low-Power Stop and Wait Modes

## 6.4 CPU Registers

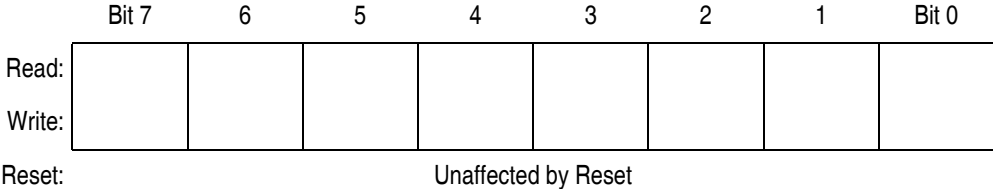
**Figure 6-1** shows the five CPU registers. CPU registers are not part of the memory map.



**Figure 6-1. CPU Registers**

**6.4.1 Accumulator**

The accumulator is a general-purpose 8-bit register. The CPU uses the accumulator to hold operands and the results of arithmetic/logic operations.



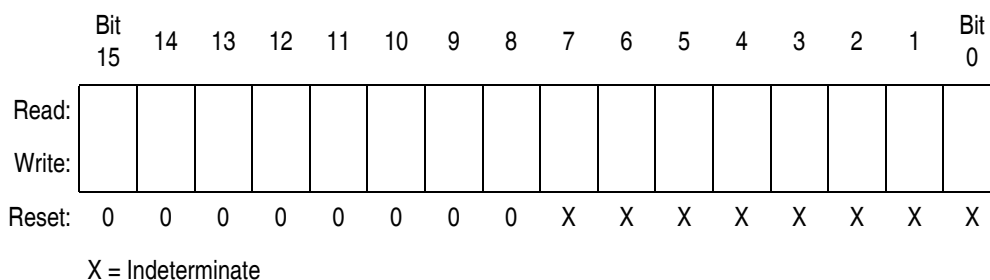
**Figure 6-2. Accumulator (A)**

**6.4.2 Index Register**

The 16-bit index register allows indexed addressing of a 64-Kbyte memory space. H is the upper byte of the index register, and X is the lower byte. H:X is the concatenated 16-bit index register.

In the indexed addressing modes, the CPU uses the contents of the index register to determine the conditional address of the operand.

The index register can serve also as a temporary data storage location.



**Figure 6-3. Index Register (H:X)**

### 6.4.3 Stack Pointer

The stack pointer is a 16-bit register that contains the address of the next location on the stack. During a reset, the stack pointer is preset to \$00FF. The reset stack pointer (RSP) instruction sets the least significant byte (LSB) to \$FF and does not affect the most significant byte (MSB). The stack pointer decrements as data is pushed onto the stack and increments as data is pulled from the stack.

In the stack pointer 8-bit offset and 16-bit offset addressing modes, the stack pointer can function as an index register to access data on the stack. The CPU uses the contents of the stack pointer to determine the conditional address of the operand.



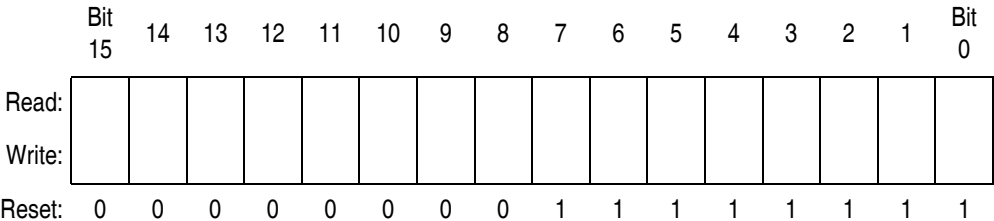


Figure 6-4. Stack Pointer (SP)

**NOTE:** The location of the stack is arbitrary and may be relocated anywhere in RAM. Moving the SP out of page 0 (\$0000 to \$00FF) frees direct address (page 0) space. For correct operation, the stack pointer must point only to RAM locations.

6.4.4 Program Counter

The program counter is a 16-bit register that contains the address of the next instruction or operand to be fetched.

Normally, the program counter automatically increments to the next sequential memory location every time an instruction or operand is fetched. Jump, branch, and interrupt operations load the program counter with an address other than that of the next sequential location.

During reset, the program counter is loaded with the reset vector address located at \$FFFE and \$FFFF. The vector address is the address of the first instruction to be executed after exiting the reset state.

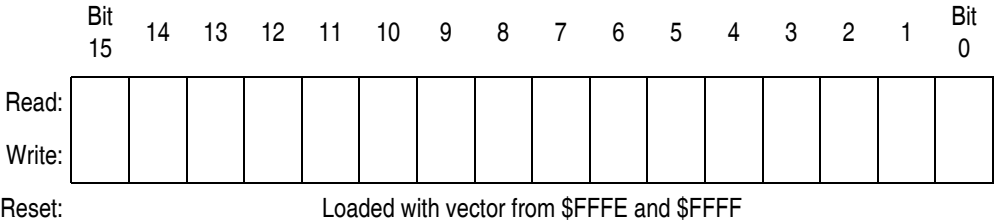


Figure 6-5. Program Counter (PC)

## 6.4.5 Condition Code Register

The 8-bit condition code register contains the interrupt mask and five flags that indicate the results of the instruction just executed. Bits 6 and 5 are set permanently to logic 1. The following paragraphs describe the functions of the condition code register.

	Bit 7	6	5	4	3	2	1	Bit 0
Read:	V	1	1	H	I	N	Z	C
Write:								
Reset:	X	1	1	X	1	X	X	X

X = Indeterminate

**Figure 6-6. Condition Code Register (CCR)**

### V — Overflow Flag

The CPU sets the overflow flag when a two's complement overflow occurs. The signed branch instructions BGT, BGE, BLE, and BLT use the overflow flag.

1 = Overflow

0 = No overflow

### H — Half-Carry Flag

The CPU sets the half-carry flag when a carry occurs between accumulator bits 3 and 4 during an add-without-carry (ADD) or add-with-carry (ADC) operation. The half-carry flag is required for binary-coded decimal (BCD) arithmetic operations. The DAA instruction uses the states of the H and C flags to determine the appropriate correction factor.

1 = Carry between bits 3 and 4

0 = No carry between bits 3 and 4

### I — Interrupt Mask

When the interrupt mask is set, all maskable CPU interrupts are disabled. CPU interrupts are enabled when the interrupt mask is cleared. When a CPU interrupt occurs, the interrupt mask is set

automatically after the CPU registers are saved on the stack, but before the interrupt vector is fetched.

1 = Interrupts disabled

0 = Interrupts enabled

**NOTE:** *To maintain M6805 compatibility, the upper byte of the index register (H) is not stacked automatically. If the interrupt service routine modifies H, then the user must stack and unstack H using the PSHH and PULH instructions.*

After the I bit is cleared, the highest-priority interrupt request is serviced first.

A return-from-interrupt (RTI) instruction pulls the CPU registers from the stack and restores the interrupt mask from the stack. After any reset, the interrupt mask is set and can only be cleared by the clear interrupt mask software instruction (CLI).

#### N — Negative flag

The CPU sets the negative flag when an arithmetic operation, logic operation, or data manipulation produces a negative result, setting bit 7 of the result.

1 = Negative result

0 = Non-negative result

#### Z — Zero flag

The CPU sets the zero flag when an arithmetic operation, logic operation, or data manipulation produce a result of \$00.

1 = Zero result

0 = Non-zero result

#### C — Carry/Borrow Flag

The CPU sets the carry/borrow flag when an addition operation produces a carry out of bit 7 of the accumulator or when a subtraction operation requires a borrow. Some instructions — such as bit test and branch, shift, and rotate — also clear or set the carry/borrow flag.

1 = Carry out of bit 7

0 = No carry out of bit 7

## 6.5 Arithmetic/Logic Unit (ALU)

The ALU performs the arithmetic and logic operations defined by the instruction set.

Refer to the *CPU08 Reference Manual* (Freescale document number CPU08RM/AD) for a description of the instructions and addressing modes and more detail about the architecture of the CPU.

## 6.6 Low-Power Modes

The WAIT and STOP instructions put the MCU in low-power standby modes.

### 6.6.1 Wait Mode

The WAIT instruction:

- Clears the interrupt mask (I bit) in the condition code register, enabling interrupts. After exit from wait mode by interrupt, the I bit remains clear. After exit by reset, the I bit is set.
- Disables the CPU clock.

### 6.6.2 Stop Mode

The STOP instruction:

- Clears the interrupt mask (I bit) in the condition code register, enabling external interrupts. After exit from stop mode by external interrupt, the I bit remains clear. After exit by reset, the I bit is set.
- Disables the CPU clock.

After exiting stop mode, the CPU clock begins running after the oscillator stabilization delay.

## 6.7 CPU During Break Interrupts

If the break module is enabled, a break interrupt causes the CPU to execute the software interrupt instruction (SWI) at the completion of the current CPU instruction. (See [Section 11. Break Module \(BRK\)](#).) The program counter vectors to \$FFFC–\$FFFD (\$FEFC–\$FEFD in monitor mode).

A return-from-interrupt instruction (RTI) in the break routine ends the break interrupt and returns the MCU to normal operation if the break interrupt has been deasserted.

## 6.8 Instruction Set Summary

Table 6-1 provides a summary of the M68HC08 instruction set.

Table 6-1. Instruction Set Summary

Source Form	Operation	Description	Effect on CCR					Address Mode	Opcode	Operand	Cycles	
			V	H	I	N	Z					C
ADC #opr ADC opr ADC opr ADC opr,X ADC opr,X ADC ,X ADC opr,SP ADC opr,SP	Add with Carry	$A \leftarrow (A) + (M) + (C)$	↑	↑	-	↑	↑	↑	IMM DIR EXT IX2 IX1 IX SP1 SP2	A9 B9 C9 D9 E9 F9 9EE9 9ED9	ii dd hh ll ee ff ff F9 ff ff	2 3 4 4 3 2 4 5
ADD #opr ADD opr ADD opr ADD opr,X ADD opr,X ADD ,X ADD opr,SP ADD opr,SP	Add without Carry	$A \leftarrow (A) + (M)$	↑	↑	-	↑	↑	↑	IMM DIR EXT IX2 IX1 IX SP1 SP2	AB BB CB DB EB FB 9EEB 9EDB	ii dd hh ll ee ff ff FB ff ff	2 3 4 4 3 2 4 5
AIS #opr	Add Immediate Value (Signed) to SP	$SP \leftarrow (SP) + (16 \ll M)$	-	-	-	-	-	-	IMM	A7	ii	2
AIX #opr	Add Immediate Value (Signed) to H:X	$H:X \leftarrow (H:X) + (16 \ll M)$	-	-	-	-	-	-	IMM	AF	ii	2
AND #opr AND opr AND opr AND opr,X AND opr,X AND ,X AND opr,SP AND opr,SP	Logical AND	$A \leftarrow (A) \& (M)$	0	-	-	↑	↑	-	IMM DIR EXT IX2 IX1 IX SP1 SP2	A4 B4 C4 D4 E4 F4 9EE4 9ED4	ii dd hh ll ee ff ff F4 ff ff	2 3 4 4 3 2 4 5
ASL opr ASLA ASLX ASL opr,X ASL ,X ASL opr,SP	Arithmetic Shift Left (Same as LSL)		↑	-	-	↑	↑	↑	DIR INH INH IX1 IX SP1	38 48 58 68 78 9E68	dd 0 ff ff	4 1 1 4 3 5
ASR opr ASRA ASRX ASR opr,X ASR opr,X ASR opr,SP	Arithmetic Shift Right		↑	-	-	↑	↑	↑	DIR INH INH IX1 IX SP1	37 47 57 67 77 9E67	dd 0 ff ff	4 1 1 4 3 5
BCC rel	Branch if Carry Bit Clear	$PC \leftarrow (PC) + 2 + rel ? (C) = 0$	-	-	-	-	-	-	REL	24	rr	3

**Table 6-1. Instruction Set Summary (Continued)**

Source Form	Operation	Description	Effect on CCR						Address Mode	Opcode	Operand	Cycles
			V	H	I	N	Z	C				
BCLR <i>n, opr</i>	Clear Bit <i>n</i> in <i>M</i>	$M_n \leftarrow 0$	-	-	-	-	-	-	DIR (b0) DIR (b1) DIR (b2) DIR (b3) DIR (b4) DIR (b5) DIR (b6) DIR (b7)	11 13 15 17 19 1B 1D 1F	dd dd dd dd dd dd dd dd	4 4 4 4 4 4 4 4
BCS <i>rel</i>	Branch if Carry Bit Set (Same as BLO)	$PC \leftarrow (PC) + 2 + rel ? (C) = 1$	-	-	-	-	-	-	REL	25	rr	3
BEQ <i>rel</i>	Branch if Equal	$PC \leftarrow (PC) + 2 + rel ? (Z) = 1$	-	-	-	-	-	-	REL	27	rr	3
BGE <i>opr</i>	Branch if Greater Than or Equal To (Signed Operands)	$PC \leftarrow (PC) + 2 + rel ? (N \oplus V) = 0$	-	-	-	-	-	-	REL	90	rr	3
BGT <i>opr</i>	Branch if Greater Than (Signed Operands)	$PC \leftarrow (PC) + 2 + rel ? (Z)   (N \oplus V) = 0$	-	-	-	-	-	-	REL	92	rr	3
BHCC <i>rel</i>	Branch if Half Carry Bit Clear	$PC \leftarrow (PC) + 2 + rel ? (H) = 0$	-	-	-	-	-	-	REL	28	rr	3
BHCS <i>rel</i>	Branch if Half Carry Bit Set	$PC \leftarrow (PC) + 2 + rel ? (H) = 1$	-	-	-	-	-	-	REL	29	rr	3
BHI <i>rel</i>	Branch if Higher	$PC \leftarrow (PC) + 2 + rel ? (C)   (Z) = 0$	-	-	-	-	-	-	REL	22	rr	3
BHS <i>rel</i>	Branch if Higher or Same (Same as BCC)	$PC \leftarrow (PC) + 2 + rel ? (C) = 0$	-	-	-	-	-	-	REL	24	rr	3
BIH <i>rel</i>	Branch if $\overline{IRQ}$ Pin High	$PC \leftarrow (PC) + 2 + rel ? \overline{IRQ} = 1$	-	-	-	-	-	-	REL	2F	rr	3
BIL <i>rel</i>	Branch if $\overline{IRQ}$ Pin Low	$PC \leftarrow (PC) + 2 + rel ? \overline{IRQ} = 0$	-	-	-	-	-	-	REL	2E	rr	3
BIT # <i>opr</i> BIT <i>opr</i> BIT <i>opr</i> BIT <i>opr,X</i> BIT <i>opr,X</i> BIT <i>X</i> BIT <i>opr,SP</i> BIT <i>opr,SP</i>	Bit Test	(A) & (M)	0	-	-	↑	↑	-	IMM DIR EXT IX2 IX1 IX SP1 SP2	A5 B5 C5 D5 E5 F5 9EE5 9ED5	ii dd hh ll ee ff ff ff ff ee ff	2 3 4 4 3 2 4 5
BLE <i>opr</i>	Branch if Less Than or Equal To (Signed Operands)	$PC \leftarrow (PC) + 2 + rel ? (Z)   (N \oplus V) = 1$	-	-	-	-	-	-	REL	93	rr	3
BLO <i>rel</i>	Branch if Lower (Same as BCS)	$PC \leftarrow (PC) + 2 + rel ? (C) = 1$	-	-	-	-	-	-	REL	25	rr	3
BLS <i>rel</i>	Branch if Lower or Same	$PC \leftarrow (PC) + 2 + rel ? (C)   (Z) = 1$	-	-	-	-	-	-	REL	23	rr	3
BLT <i>opr</i>	Branch if Less Than (Signed Operands)	$PC \leftarrow (PC) + 2 + rel ? (N \oplus V) = 1$	-	-	-	-	-	-	REL	91	rr	3
BMC <i>rel</i>	Branch if Interrupt Mask Clear	$PC \leftarrow (PC) + 2 + rel ? (I) = 0$	-	-	-	-	-	-	REL	2C	rr	3
BMI <i>rel</i>	Branch if Minus	$PC \leftarrow (PC) + 2 + rel ? (N) = 1$	-	-	-	-	-	-	REL	2B	rr	3
BMS <i>rel</i>	Branch if Interrupt Mask Set	$PC \leftarrow (PC) + 2 + rel ? (I) = 1$	-	-	-	-	-	-	REL	2D	rr	3

### Table 6-1. Instruction Set Summary (Continued)

Source Form	Operation	Description	Effect on CCR					Address Mode	Opcode	Operand	Cycles
			V	H	I	N	Z				
BNE <i>rel</i>	Branch if Not Equal	$PC \leftarrow (PC) + 2 + rel ? (Z) = 0$	-	-	-	-	-	REL	26	rr	3
BPL <i>rel</i>	Branch if Plus	$PC \leftarrow (PC) + 2 + rel ? (N) = 0$	-	-	-	-	-	REL	2A	rr	3
BRA <i>rel</i>	Branch Always	$PC \leftarrow (PC) + 2 + rel$	-	-	-	-	-	REL	20	rr	3
BRCLR <i>n,opr,rel</i>	Branch if Bit <i>n</i> in M Clear	$PC \leftarrow (PC) + 3 + rel ? (Mn) = 0$	-	-	-	-	↓	DIR (b0) DIR (b1) DIR (b2) DIR (b3) DIR (b4) DIR (b5) DIR (b6) DIR (b7)	01 03 05 07 09 0B 0D 0F	dd rr dd rr dd rr dd rr dd rr dd rr dd rr dd rr	5 5 5 5 5 5 5 5
BRN <i>rel</i>	Branch Never	$PC \leftarrow (PC) + 2$	-	-	-	-	-	REL	21	rr	3
BRSET <i>n,opr,rel</i>	Branch if Bit <i>n</i> in M Set	$PC \leftarrow (PC) + 3 + rel ? (Mn) = 1$	-	-	-	-	↓	DIR (b0) DIR (b1) DIR (b2) DIR (b3) DIR (b4) DIR (b5) DIR (b6) DIR (b7)	00 02 04 06 08 0A 0C 0E	dd rr dd rr dd rr dd rr dd rr dd rr dd rr dd rr	5 5 5 5 5 5 5 5
BSET <i>n,opr</i>	Set Bit <i>n</i> in M	$Mn \leftarrow 1$	-	-	-	-	-	DIR (b0) DIR (b1) DIR (b2) DIR (b3) DIR (b4) DIR (b5) DIR (b6) DIR (b7)	10 12 14 16 18 1A 1C 1E	dd dd dd dd dd dd dd dd	4 4 4 4 4 4 4 4
BSR <i>rel</i>	Branch to Subroutine	$PC \leftarrow (PC) + 2$ ; push (PCL) $SP \leftarrow (SP) - 1$ ; push (PCH) $SP \leftarrow (SP) - 1$ $PC \leftarrow (PC) + rel$	-	-	-	-	-	REL	AD	rr	4
CBEQ <i>opr,rel</i> CBEQA # <i>opr,rel</i> CBEQX # <i>opr,rel</i> CBEQ <i>opr,X+,rel</i> CBEQ <i>X+,rel</i> CBEQ <i>opr,SP,rel</i>	Compare and Branch if Equal	$PC \leftarrow (PC) + 3 + rel ? (A) - (M) = \$00$ $PC \leftarrow (PC) + 3 + rel ? (A) - (M) = \$00$ $PC \leftarrow (PC) + 3 + rel ? (X) - (M) = \$00$ $PC \leftarrow (PC) + 3 + rel ? (A) - (M) = \$00$ $PC \leftarrow (PC) + 2 + rel ? (A) - (M) = \$00$ $PC \leftarrow (PC) + 4 + rel ? (A) - (M) = \$00$	-	-	-	-	-	DIR IMM IMM IX1+ IX+ SP1	31 41 51 61 71 9E61	dd rr ii rr ii rr ff rr rr ff rr	5 4 4 5 4 6
CLC	Clear Carry Bit	$C \leftarrow 0$	-	-	-	-	0	INH	98		1
CLI	Clear Interrupt Mask	$I \leftarrow 0$	-	-	0	-	-	INH	9A		2
CLR <i>opr</i> CLRA CLR X CLR H CLR <i>opr,X</i> CLR ,X CLR <i>opr,SP</i>	Clear	$M \leftarrow \$00$ $A \leftarrow \$00$ $X \leftarrow \$00$ $H \leftarrow \$00$ $M \leftarrow \$00$ $M \leftarrow \$00$ $M \leftarrow \$00$	0	-	-	0	1	DIR INH INH INH IX1 IX SP1	3F 4F 5F 8C 6F 7F 9E6F	dd    ff ff	3 1 1 1 3 2 4



Table 6-1. Instruction Set Summary (Continued)

Source Form	Operation	Description	Effect on CCR						Address Mode	Opcode	Operand	Cycles
			V	H	I	N	Z	C				
CMP #opr CMP opr CMP opr CMP opr,X CMP opr,X CMP ,X CMP opr,SP CMP opr,SP	Compare A with M	(A) – (M)	↓	–	–	↓	↓	↓	IMM DIR EXT IX2 IX1 IX SP1 SP2	A1 B1 C1 D1 E1 F1 9EE1 9ED1	ii dd hh ll ee ff ff ff ff ee ff	2 3 4 4 3 2 4 5
COM opr COMA COMX COM opr,X COM ,X COM opr,SP	Complement (One's Complement)	$M \leftarrow (\overline{M}) = \$FF - (M)$ $A \leftarrow (\overline{A}) = \$FF - (M)$ $X \leftarrow (\overline{X}) = \$FF - (M)$ $M \leftarrow (\overline{M}) = \$FF - (M)$ $M \leftarrow (\overline{M}) = \$FF - (M)$ $M \leftarrow (\overline{M}) = \$FF - (M)$	0	–	–	↓	↓	1	DIR INH INH IX1 IX SP1	33 43 53 63 73 9E63	dd ff ff ff	4 1 1 4 3 5
CPHX #opr CPHX opr	Compare H:X with M	(H:X) – (M:M + 1)	↓	–	–	↓	↓	↓	IMM DIR	65 75	ii ii+1 dd	3 4
CPX #opr CPX opr CPX opr CPX ,X CPX opr,X CPX opr,X CPX opr,SP CPX opr,SP	Compare X with M	(X) – (M)	↓	–	–	↓	↓	↓	IMM DIR EXT IX2 IX1 IX SP1 SP2	A3 B3 C3 D3 E3 F3 9EE3 9ED3	ii dd hh ll ee ff ff ff ff ee ff	2 3 4 4 3 2 4 5
DAA	Decimal Adjust A	(A) <sub>10</sub>	U	–	–	↓	↓	↓	INH	72		2
DBNZ opr,rel DBNZA rel DBNZX rel DBNZ opr,X,rel DBNZ X,rel DBNZ opr,SP,rel	Decrement and Branch if Not Zero	$A \leftarrow (A) - 1$ or $M \leftarrow (M) - 1$ or $X \leftarrow (X) - 1$ $PC \leftarrow (PC) + 3 + rel ? (result) \neq 0$ $PC \leftarrow (PC) + 2 + rel ? (result) \neq 0$ $PC \leftarrow (PC) + 2 + rel ? (result) \neq 0$ $PC \leftarrow (PC) + 3 + rel ? (result) \neq 0$ $PC \leftarrow (PC) + 2 + rel ? (result) \neq 0$ $PC \leftarrow (PC) + 4 + rel ? (result) \neq 0$	–	–	–	–	–	–	DIR INH INH IX1 IX SP1	3B 4B 5B 6B 7B 9E6B	dd rr rr rr rr rr ff rr rr rr ff rr	5 3 3 5 4 6
DEC opr DECA DECX DEC opr,X DEC ,X DEC opr,SP	Decrement	$M \leftarrow (M) - 1$ $A \leftarrow (A) - 1$ $X \leftarrow (X) - 1$ $M \leftarrow (M) - 1$ $M \leftarrow (M) - 1$ $M \leftarrow (M) - 1$	↓	–	–	↓	↓	–	DIR INH INH IX1 IX SP1	3A 4A 5A 6A 7A 9E6A	dd ff ff ff	4 1 1 4 3 5
DIV	Divide	$A \leftarrow (H:A)/(X)$ H ← Remainder	–	–	–	–	↓	↓	INH	52		7
EOR #opr EOR opr EOR opr EOR opr,X EOR opr,X EOR ,X EOR opr,SP EOR opr,SP	Exclusive OR M with A	$A \leftarrow (A \oplus M)$	0	–	–	↓	↓	–	IMM DIR EXT IX2 IX1 IX SP1 SP2	A8 B8 C8 D8 E8 F8 9EE8 9ED8	ii dd hh ll ee ff ff ff ff ee ff	2 3 4 4 4 3 2 4 5

## Table 6-1. Instruction Set Summary (Continued)

Source Form	Operation	Description	Effect on CCR					Address Mode	Opcode	Operand	Cycles	
			V	H	I	N	Z					C
INC <i>opr</i> INCA INCX INC <i>opr</i> ,X INC ,X INC <i>opr</i> ,SP	Increment	$M \leftarrow (M) + 1$ $A \leftarrow (A) + 1$ $X \leftarrow (X) + 1$ $M \leftarrow (M) + 1$ $M \leftarrow (M) + 1$ $M \leftarrow (M) + 1$	↓	-	-	↑	↑	-	DIR INH INH IX1 IX SP1	3C 4C 5C 6C 7C 9E6C	dd hh ll ff ff ff	4 1 1 4 3 5
JMP <i>opr</i> JMP <i>opr</i> JMP <i>opr</i> ,X JMP <i>opr</i> ,X JMP ,X	Jump	PC ← Jump Address	-	-	-	-	-	-	DIR EXT IX2 IX1 IX	BC CC DC EC FC	dd hh ll ee ff ff	2 3 4 3 2
JSR <i>opr</i> JSR <i>opr</i> JSR <i>opr</i> ,X JSR <i>opr</i> ,X JSR ,X	Jump to Subroutine	$PC \leftarrow (PC) + n$ ( $n = 1, 2, \text{ or } 3$ ) Push (PCL); $SP \leftarrow (SP) - 1$ Push (PCH); $SP \leftarrow (SP) - 1$ PC ← Unconditional Address	-	-	-	-	-	-	DIR EXT IX2 IX1 IX	BD CD DD ED FD	dd hh ll ee ff ff	4 5 6 5 4
LDA # <i>opr</i> LDA <i>opr</i> LDA <i>opr</i> LDA <i>opr</i> ,X LDA <i>opr</i> ,X LDA ,X LDA <i>opr</i> ,SP LDA <i>opr</i> ,SP	Load A from M	$A \leftarrow (M)$	0	-	-	↑	↑	-	IMM DIR EXT IX2 IX1 IX SP1 SP2	A6 B6 C6 D6 E6 F6 9EE6 9ED6	ii dd hh ll ee ff ff ff ff ee ff	2 3 4 4 3 2 4 5
LDHX # <i>opr</i> LDHX <i>opr</i>	Load H:X from M	$H:X \leftarrow (M:M + 1)$	0	-	-	↑	↑	-	IMM DIR	45 55	ii jj dd	3 4
LDX # <i>opr</i> LDX <i>opr</i> LDX <i>opr</i> LDX <i>opr</i> ,X LDX <i>opr</i> ,X LDX ,X LDX <i>opr</i> ,SP LDX <i>opr</i> ,SP	Load X from M	$X \leftarrow (M)$	0	-	-	↑	↑	-	IMM DIR EXT IX2 IX1 IX SP1 SP2	AE BE CE DE EE FE 9EEE 9EDE	ii dd hh ll ee ff ee ff ff ff ee ff	2 3 4 4 3 2 4 5
LSL <i>opr</i> LSLA LSLX LSL <i>opr</i> ,X LSL ,X LSL <i>opr</i> ,SP	Logical Shift Left (Same as ASL)		↑	-	-	↑	↑	↑	DIR INH INH IX1 IX SP1	38 48 58 68 78 9E68	dd ff ff	4 1 1 4 3 5
LSR <i>opr</i> LSRA LSRX LSR <i>opr</i> ,X LSR ,X LSR <i>opr</i> ,SP	Logical Shift Right		↑	-	-	0	↑	↑	DIR INH INH IX1 IX SP1	34 44 54 64 74 9E64	dd ff ff	4 1 1 4 3 5
MOV <i>opr</i> , <i>opr</i> MOV <i>opr</i> ,X+ MOV # <i>opr</i> , <i>opr</i> MOV X+, <i>opr</i>	Move	$(M)_{\text{Destination}} \leftarrow (M)_{\text{Source}}$ $H:X \leftarrow (H:X) + 1$ (IX+D, DIX+)	0	-	-	↑	↑	-	DD DIX+ IMD IX+D	4E 5E 6E 7E	dd dd dd ii dd dd	5 4 4 4
MUL	Unsigned multiply	$X:A \leftarrow (X) \times (A)$	-	0	-	-	-	0	INH	42		5

Table 6-1. Instruction Set Summary (Continued)

Source Form	Operation	Description	Effect on CCR					Address Mode	Opcode	Operand	Cycles	
			V	H	I	N	Z					C
NEG <i>opr</i> NEGA NEGX NEG <i>opr,X</i> NEG ,X NEG <i>opr,SP</i>	Negate (Two's Complement)	$M \leftarrow -(M) = \$00 - (M)$ $A \leftarrow -(A) = \$00 - (A)$ $X \leftarrow -(X) = \$00 - (X)$ $M \leftarrow -(M) = \$00 - (M)$ $M \leftarrow -(M) = \$00 - (M)$	↓	-	-	↑	↑	↑	DIR INH INH IX1 IX SP1	30 40 50 60 70 9E60	dd ff ff	4 1 1 4 3 5
NOP	No Operation	None	-	-	-	-	-	-	INH	9D		1
NSA	Nibble Swap A	$A \leftarrow (A[3:0]:A[7:4])$	-	-	-	-	-	-	INH	62		3
ORA # <i>opr</i> ORA <i>opr</i> ORA <i>opr</i> ORA <i>opr,X</i> ORA <i>opr,X</i> ORA ,X ORA <i>opr,SP</i> ORA <i>opr,SP</i>	Inclusive OR A and M	$A \leftarrow (A)   (M)$	0	-	-	↑	↑	-	IMM DIR EXT IX2 IX1 IX SP1 SP2	AA BA CA DA EA FA 9EEA 9EDA	ii dd hh ll ee ff ff ff ee ff	2 3 4 4 3 2 4 5
PSHA	Push A onto Stack	Push (A); $SP \leftarrow (SP) - 1$	-	-	-	-	-	-	INH	87		2
PSHH	Push H onto Stack	Push (H); $SP \leftarrow (SP) - 1$	-	-	-	-	-	-	INH	8B		2
PSHX	Push X onto Stack	Push (X); $SP \leftarrow (SP) - 1$	-	-	-	-	-	-	INH	89		2
PULA	Pull A from Stack	$SP \leftarrow (SP + 1)$ ; Pull (A)	-	-	-	-	-	-	INH	86		2
PULH	Pull H from Stack	$SP \leftarrow (SP + 1)$ ; Pull (H)	-	-	-	-	-	-	INH	8A		2
PULX	Pull X from Stack	$SP \leftarrow (SP + 1)$ ; Pull (X)	-	-	-	-	-	-	INH	88		2
ROL <i>opr</i> ROLA ROLX ROL <i>opr,X</i> ROL ,X ROL <i>opr,SP</i>	Rotate Left through Carry		↓	-	-	↑	↑	↑	DIR INH INH IX1 IX SP1	39 49 59 69 79 9E69	dd ff ff	4 1 1 4 3 5
ROR <i>opr</i> RORA RORX ROR <i>opr,X</i> ROR ,X ROR <i>opr,SP</i>	Rotate Right through Carry		↓	-	-	↑	↑	↑	DIR INH INH IX1 IX SP1	36 46 56 66 76 9E66	dd ff ff	4 1 1 4 3 5
RSP	Reset Stack Pointer	$SP \leftarrow \$FF$	-	-	-	-	-	-	INH	9C		1
RTI	Return from Interrupt	$SP \leftarrow (SP) + 1$ ; Pull (CCR) $SP \leftarrow (SP) + 1$ ; Pull (A) $SP \leftarrow (SP) + 1$ ; Pull (X) $SP \leftarrow (SP) + 1$ ; Pull (PCH) $SP \leftarrow (SP) + 1$ ; Pull (PCL)	↓	↑	↑	↑	↑	↑	INH	80		7
RTS	Return from Subroutine	$SP \leftarrow SP + 1$ ; Pull (PCH) $SP \leftarrow SP + 1$ ; Pull (PCL)	-	-	-	-	-	-	INH	81		4

## Table 6-1. Instruction Set Summary (Continued)

Source Form	Operation	Description	Effect on CCR						Address Mode	Opcode	Operand	Cycles
			V	H	I	N	Z	C				
SBC #opr SBC opr SBC opr SBC opr,X SBC opr,X SBC ,X SBC opr,SP SBC opr,SP	Subtract with Carry	$A \leftarrow (A) - (M) - (C)$	↓	-	-	↓	↓	↓	IMM DIR EXT IX2 IX1 IX SP1 SP2	A2 B2 C2 D2 E2 F2 9EE2 9ED2	ii dd hh ll ee ff ff ff ff ff	2 3 4 4 3 2 4 5
SEC	Set Carry Bit	$C \leftarrow 1$	-	-	-	-	-	1	INH	99		1
SEI	Set Interrupt Mask	$I \leftarrow 1$	-	-	1	-	-	-	INH	9B		2
STA opr STA opr STA opr,X STA opr,X STA ,X STA opr,SP STA opr,SP	Store A in M	$M \leftarrow (A)$	0	-	-	↓	↓	-	DIR EXT IX2 IX1 IX SP1 SP2	B7 C7 D7 E7 F7 9EE7 9ED7	dd hh ll ee ff ff ff ff ff	3 4 4 3 2 4 5
STHX opr	Store H:X in M	$(M:M + 1) \leftarrow (H:X)$	0	-	-	↓	↓	-	DIR	35	dd	4
STOP	Enable $\overline{IRQ}$ Pin; Stop Oscillator	$I \leftarrow 0$ ; Stop Oscillator	-	-	0	-	-	-	INH	8E		1
STX opr STX opr STX opr,X STX opr,X STX ,X STX opr,SP STX opr,SP	Store X in M	$M \leftarrow (X)$	0	-	-	↓	↓	-	DIR EXT IX2 IX1 IX SP1 SP2	BF CF DF EF FF 9EEF 9EDF	dd hh ll ee ff ff ff ff ff	3 4 4 3 2 4 5
SUB #opr SUB opr SUB opr SUB opr,X SUB opr,X SUB ,X SUB opr,SP SUB opr,SP	Subtract	$A \leftarrow (A) - (M)$	↓	-	-	↓	↓	↓	IMM DIR EXT IX2 IX1 IX SP1 SP2	A0 B0 C0 D0 E0 F0 9EE0 9ED0	ii dd hh ll ee ff ff ff ff ff	2 3 4 4 3 2 4 5
SWI	Software Interrupt	$PC \leftarrow (PC) + 1$ ; Push (PCL) $SP \leftarrow (SP) - 1$ ; Push (PCH) $SP \leftarrow (SP) - 1$ ; Push (X) $SP \leftarrow (SP) - 1$ ; Push (A) $SP \leftarrow (SP) - 1$ ; Push (CCR) $SP \leftarrow (SP) - 1$ ; $I \leftarrow 1$ PCH ← Interrupt Vector High Byte PCL ← Interrupt Vector Low Byte	-	-	1	-	-	-	INH	83		9
TAP	Transfer A to CCR	$CCR \leftarrow (A)$	↓	↓	↓	↓	↓	↓	INH	84		2
TAX	Transfer A to X	$X \leftarrow (A)$	-	-	-	-	-	-	INH	97		1
TPA	Transfer CCR to A	$A \leftarrow (CCR)$	-	-	-	-	-	-	INH	85		1

**Table 6-1. Instruction Set Summary (Continued)**

Source Form	Operation	Description	Effect on CCR					Address Mode	Opcode	Operand	Cycles	
			V	H	I	N	Z					C
TST <i>opr</i> TSTA TSTX TST <i>opr,X</i> TST ,X TST <i>opr,SP</i>	Test for Negative or Zero	(A) – \$00 or (X) – \$00 or (M) – \$00	0	—	—	↑	↓	—	DIR INH INH IX1 IX SP1	3D 4D 5D 6D 7D 9E6D	dd ff ff	3 1 1 3 2 4
TSX	Transfer SP to H:X	H:X ← (SP) + 1	—	—	—	—	—	—	INH	95		2
TXA	Transfer X to A	A ← (X)	—	—	—	—	—	—	INH	9F		1
TXS	Transfer H:X to SP	(SP) ← (H:X) – 1	—	—	—	—	—	—	INH	94		2

A	Accumulator	<i>n</i>	Any bit
C	Carry/borrow bit	<i>opr</i>	Operand (one or two bytes)
CCR	Condition code register	PC	Program counter
dd	Direct address of operand	PCH	Program counter high byte
dd rr	Direct address of operand and relative offset of branch instruction	PCL	Program counter low byte
DD	Direct to direct addressing mode	REL	Relative addressing mode
DIR	Direct addressing mode	<i>rel</i>	Relative program counter offset byte
DIX+	Direct to indexed with post increment addressing mode	rr	Relative program counter offset byte
ee ff	High and low bytes of offset in indexed, 16-bit offset addressing	SP1	Stack pointer, 8-bit offset addressing mode
EXT	Extended addressing mode	SP2	Stack pointer 16-bit offset addressing mode
ff	Offset byte in indexed, 8-bit offset addressing	SP	Stack pointer
H	Half-carry bit	U	Undefined
H	Index register high byte	V	Overflow bit
hh ll	High and low bytes of operand address in extended addressing	X	Index register low byte
I	Interrupt mask	Z	Zero bit
ii	Immediate operand byte	&	Logical AND
IMD	Immediate source to direct destination addressing mode		Logical OR
IMM	Immediate addressing mode	⊕	Logical EXCLUSIVE OR
INH	Inherent addressing mode	( )	Contents of
IX	Indexed, no offset addressing mode	–( )	Negation (two's complement)
IX+	Indexed, no offset, post increment addressing mode	#	Immediate value
IX+D	Indexed with post increment to direct addressing mode	«	Sign extend
IX1	Indexed, 8-bit offset addressing mode	←	Loaded with
IX1+	Indexed, 8-bit offset, post increment addressing mode	?	If
IX2	Indexed, 16-bit offset addressing mode	:	Concatenated with
M	Memory location	↑	Set or cleared
N	Negative bit	—	Not affected

## 6.9 Opcode Map

The opcode map is provided in [Table 6-2](#).

**Table 6-2. Opcode Map**

MSB LSB	Bit Manipulation		Branch	Read-Modify-Write						Control			Register/Memory						
	DIR	DIR	REL	DIR	INH	INH	IX1	SP1	IX	INH	INH	IMM	DIR	EXT	IX2	SP2	IX1	SP1	IX
	0	1	2	3	4	5	6	9E6	7	8	9	A	B	C	D	9ED	E	9EE	F
0	BRSET0 3 DIR	BSET0 2 DIR	BRA 2 REL	NEG 2 DIR	NEGA 1 INH	NEGX 1 INH	NEG 2 IX1	NEG 3 SP1	NEG 1 IX	RTI 1 INH	BGE 2 REL	SUB 2 IMM	SUB 2 DIR	SUB 3 EXT	SUB 3 IX2	SUB 4 SP2	SUB 2 IX1	SUB 3 SP1	SUB 1 IX
1	BRCLR0 3 DIR	BCLR0 2 DIR	BRN 2 REL	CBEQ 3 DIR	CBEQA 3 IMM	CBEQX 3 IMM	CBEQ 3 IX1+	CBEQ 4 SP1	CBEQ 2 IX+	RTS 1 INH	BLT 2 REL	CMP 2 IMM	CMP 2 DIR	CMP 3 EXT	CMP 3 IX2	CMP 4 SP2	CMP 2 IX1	CMP 3 SP1	CMP 1 IX
2	BRSET1 3 DIR	BSET1 2 DIR	BHI 2 REL		MUL 1 INH	DIV 1 INH	NSA 1 INH		DAA 1 INH		BGT 2 REL	SBC 2 IMM	SBC 2 DIR	SBC 3 EXT	SBC 3 IX2	SBC 4 SP2	SBC 2 IX1	SBC 3 SP1	SBC 1 IX
3	BRCLR1 3 DIR	BCLR1 2 DIR	BLS 2 REL	COM 2 DIR	COMA 1 INH	COMX 1 INH	COM 2 IX1	COM 3 SP1	COM 1 IX	SWI 1 INH	BLE 2 REL	CPX 2 IMM	CPX 2 DIR	CPX 3 EXT	CPX 3 IX2	CPX 4 SP2	CPX 2 IX1	CPX 3 SP1	CPX 1 IX
4	BRSET2 3 DIR	BSET2 2 DIR	BCC 2 REL	LSR 2 DIR	LSRA 1 INH	LSRX 1 INH	LSR 2 IX1	LSR 3 SP1	LSR 1 IX	TAP 1 INH	TXS 1 INH	AND 2 IMM	AND 2 DIR	AND 3 EXT	AND 3 IX2	AND 4 SP2	AND 2 IX1	AND 3 SP1	AND 1 IX
5	BRCLR2 3 DIR	BCLR2 2 DIR	BCS 2 REL	STHX 2 DIR	LDHX 3 IMM	LDHX 2 DIR	CPHX 3 IMM		CPHX 2 DIR	TPA 1 INH	TSX 1 INH	BIT 2 IMM	BIT 2 DIR	BIT 3 EXT	BIT 3 IX2	BIT 4 SP2	BIT 2 IX1	BIT 3 SP1	BIT 1 IX
6	BRSET3 3 DIR	BSET3 2 DIR	BNE 2 REL	ROR 2 DIR	RORA 1 INH	RORX 1 INH	ROR 2 IX1	ROR 3 SP1	ROR 1 IX	PULA 1 INH		LDA 2 IMM	LDA 3 DIR	LDA 4 EXT	LDA 4 IX2	LDA 5 SP2	LDA 3 IX1	LDA 4 SP1	LDA 2 IX
7	BRCLR3 3 DIR	BCLR3 2 DIR	BEQ 2 REL	ASR 2 DIR	ASRA 1 INH	ASRX 1 INH	ASR 2 IX1	ASR 3 SP1	ASR 1 IX	PSHA 1 INH	TAX 1 INH	AIS 2 IMM	STA 2 DIR	STA 3 EXT	STA 3 IX2	STA 4 SP2	STA 2 IX1	STA 3 SP1	STA 1 IX
8	BRSET4 3 DIR	BSET4 2 DIR	BHCC 2 REL	LSL 2 DIR	LSLA 1 INH	LSLX 1 INH	LSL 2 IX1	LSL 3 SP1	LSL 1 IX	PULX 1 INH	CLC 1 INH	EOR 2 IMM	EOR 2 DIR	EOR 3 EXT	EOR 3 IX2	EOR 4 SP2	EOR 2 IX1	EOR 3 SP1	EOR 1 IX
9	BRCLR4 3 DIR	BCLR4 2 DIR	BHCS 2 REL	ROL 2 DIR	ROLA 1 INH	ROLX 1 INH	ROL 2 IX1	ROL 3 SP1	ROL 1 IX	PSHX 1 INH	SEC 1 INH	ADC 2 IMM	ADC 2 DIR	ADC 3 EXT	ADC 3 IX2	ADC 4 SP2	ADC 2 IX1	ADC 3 SP1	ADC 1 IX
A	BRSET5 3 DIR	BSET5 2 DIR	BPL 2 REL	DEC 2 DIR	DECA 1 INH	DECX 1 INH	DEC 2 IX1	DEC 3 SP1	DEC 1 IX	PULH 1 INH	CLI 1 INH	ORA 2 IMM	ORA 2 DIR	ORA 3 EXT	ORA 3 IX2	ORA 4 SP2	ORA 2 IX1	ORA 3 SP1	ORA 1 IX
B	BRCLR5 3 DIR	BCLR5 2 DIR	BMI 2 REL	DBNZ 3 DIR	DBNZA 2 INH	DBNZX 2 INH	DBNZ 3 IX1	DBNZ 4 SP1	DBNZ 2 IX	PSHH 1 INH	SEI 1 INH	ADD 2 IMM	ADD 2 DIR	ADD 3 EXT	ADD 3 IX2	ADD 4 SP2	ADD 2 IX1	ADD 3 SP1	ADD 1 IX
C	BRSET6 3 DIR	BSET6 2 DIR	BMC 2 REL	INC 2 DIR	INCA 1 INH	INCX 1 INH	INC 2 IX1	INC 3 SP1	INC 1 IX	CLRH 1 INH	RSP 1 INH		JMP 2 DIR	JMP 3 EXT	JMP 3 IX2		JMP 2 IX1		JMP 1 IX
D	BRCLR6 3 DIR	BCLR6 2 DIR	BMS 2 REL	TST 2 DIR	TSTA 1 INH	TSTX 1 INH	TST 2 IX1	TST 3 SP1	TST 1 IX		NOP 1 INH	BSR 2 REL	JSR 2 DIR	JSR 3 EXT	JSR 3 IX2		JSR 2 IX1		JSR 1 IX
E	BRSET7 3 DIR	BSET7 2 DIR	BIL 2 REL		MOV 3 DD	MOV 4 DIX+	MOV 3 IMD		MOV 2 IX+D	STOP 1 INH	*	LDX 2 IMM	LDX 2 DIR	LDX 3 EXT	LDX 3 IX2	LDX 4 SP2	LDX 2 IX1	LDX 3 SP1	LDX 1 IX
F	BRCLR7 3 DIR	BCLR7 2 DIR	BIH 2 REL	CLR 2 DIR	CLRA 1 INH	CLRX 1 INH	CLR 2 IX1	CLR 3 SP1	CLR 1 IX	WAIT 1 INH	TXA 1 INH	AIX 2 IMM	STX 2 DIR	STX 3 EXT	STX 3 IX2	STX 4 SP2	STX 2 IX1	STX 3 SP1	STX 1 IX

INH Inherent  
IMM Immediate  
DIR Direct  
EXT Extended  
DD Direct-Direct  
IX+D Indexed-Direct

REL Relative  
IX Indexed, No Offset  
IX1 Indexed, 8-Bit Offset  
IX2 Indexed, 16-Bit Offset  
IMD Immediate-Direct  
DIX+ Direct-Indexed

SP1 Stack Pointer, 8-Bit Offset  
SP2 Stack Pointer, 16-Bit Offset  
IX+ Indexed, No Offset with Post Increment  
IX1+ Indexed, 1-Byte Offset with Post Increment

\*Pre-byte for stack pointer indexed instructions

Low Byte of Opcode in Hexadecimal

MSB LSB	0
0	BRSET0 3 DIR

High Byte of Opcode in Hexadecimal  
Cycles  
Opcode Mnemonic  
Number of Bytes / Addressing Mode

## Section 7. System Integration Module (SIM)

### 7.1 Contents

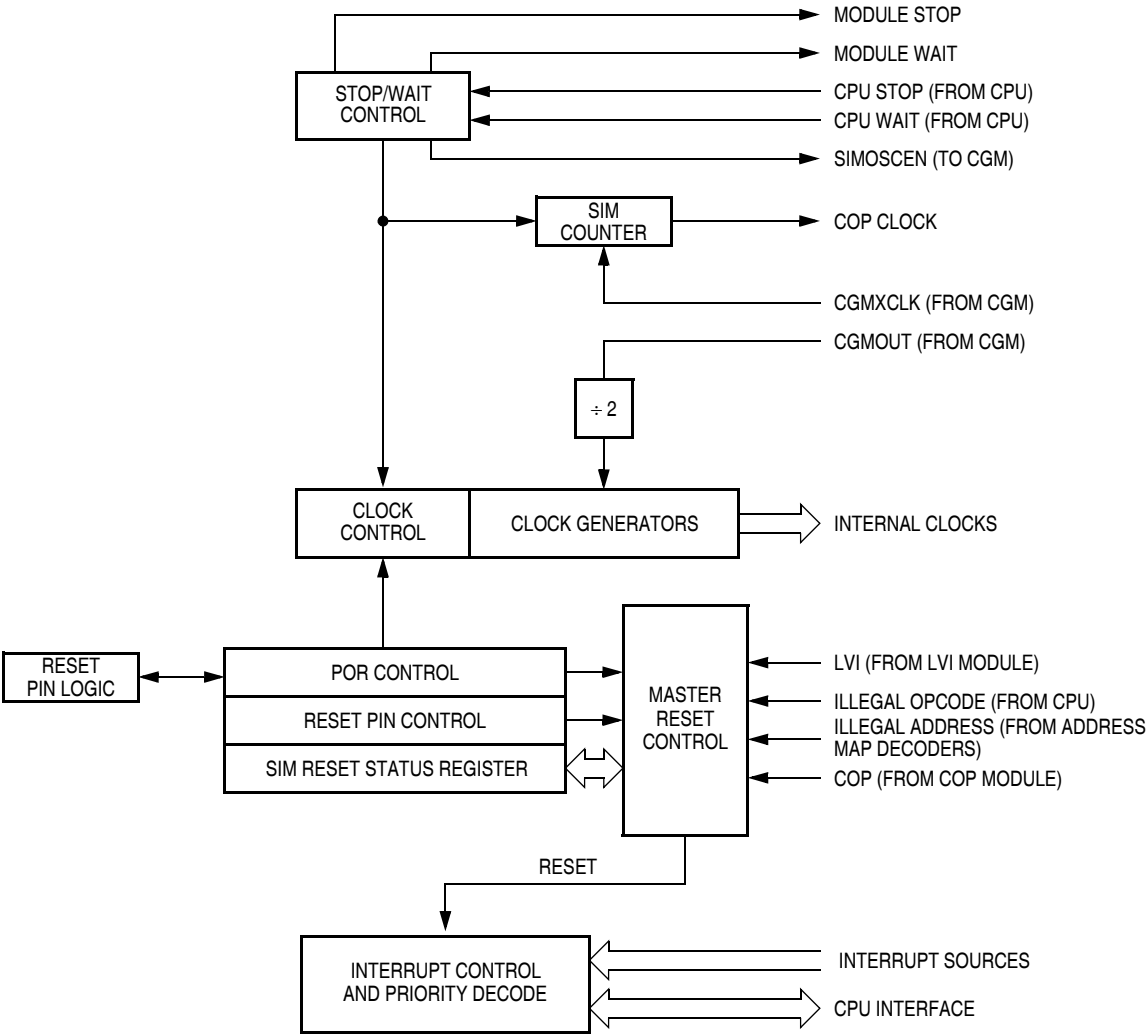
7.2	Introduction . . . . .	116
7.3	SIM Bus Clock Control and Generation . . . . .	119
7.3.1	Bus Timing . . . . .	119
7.3.2	Clock Startup from POR or LVI Reset. . . . .	119
7.3.3	Clocks in Stop Mode and Wait Mode . . . . .	120
7.4	Reset and System Initialization. . . . .	120
7.4.1	External Pin Reset. . . . .	121
7.4.2	Active Resets from Internal Sources. . . . .	122
7.4.2.1	Power-On Reset . . . . .	123
7.4.2.2	Computer Operating Properly (COP) Reset. . . . .	124
7.4.2.3	Illegal Opcode Reset . . . . .	124
7.4.2.4	Illegal Address Reset. . . . .	124
7.4.2.5	Low-Voltage Inhibit (LVI) Reset . . . . .	124
7.5	SIM Counter . . . . .	125
7.5.1	SIM Counter During Power-On Reset. . . . .	125
7.5.2	SIM Counter During Stop Mode Recovery . . . . .	125
7.5.3	SIM Counter and Reset States . . . . .	125
7.6	Program Exception Control. . . . .	126
7.6.1	Interrupts . . . . .	126
7.6.2	Reset. . . . .	130
7.6.3	Break Interrupts. . . . .	130
7.6.4	Status Flag Protection in Break Mode. . . . .	130
7.7	Low-Power Modes . . . . .	131
7.7.1	Wait Mode . . . . .	131
7.7.2	Stop Mode. . . . .	133
7.8	SIM Registers . . . . .	134
7.8.1	SIM Break Status Register . . . . .	134
7.8.2	SIM Reset Status Register . . . . .	136
7.8.3	SIM Break Flag Control Register. . . . .	137

## 7.2 Introduction

This section describes the system integration module (SIM), which supports up to 24 external and/or internal interrupts. Together with the central processor unit (CPU), the SIM controls all MCU activities. A block diagram of the SIM is shown in [Figure 7-1](#). [Table 7-1](#) is a summary of the SIM input/output (I/O) registers. The SIM is a system state controller that coordinates CPU and exception timing. The SIM is responsible for:

- Bus clock generation and control for CPU and peripherals
  - Stop/wait/reset/break entry and recovery
  - Internal clock control
- Master reset control, including power-on reset (POR) and computer operating properly (COP) timeout
- Interrupt control:
  - Acknowledge timing
  - Arbitration control timing
  - Vector address generation
- CPU enable/disable timing
- Modular architecture expandable to 128 interrupt sources





**Figure 7-1. SIM Block Diagram**



**Table 7-1. SIM I/O Register Summary**

Addr.	Register Name	Bit 7	6	5	4	3	2	1	Bit 0	
\$FE00	SIM Break Status Register (SBSR)	Read:	R	R	R	R	R	SBSW	R	
		Write:						See Note		
		Reset:	0							
\$FE01	SIM Reset Status Register (SRSR)	Read:	POR	PIN	COP	ILOP	ILAD	0	LVI	0
		Write:								
		Reset:	1	X	0	0	0	0	X	0
\$FE03	SIM Break Flag Control Register (SBFCR)	Read:	BCFE	R	R	R	R	R	R	R
		Write:								
		Reset:	0	0						

NOTE: Writing a logic 0 clears SBSW

R	= Reserved	X = Indeterminate
---	------------	-------------------

**Table 7-2. I/O Register Address Summary**

<b>Register</b>	SBSR	SRSR	SBFCR
<b>Address</b>	\$FE00	\$FE01	\$FE03

**Table 7-3** shows the internal signal names used in this section.

**Table 7-3. Signal Name Conventions**

Signal Name	Description
CGMXCLK	Buffered Version of OSC1 from Clock Generator Module (CGM)
CGMVCLK	PLL Output
CGMOUT	PLL-Based or OSC1-Based Clock Output from CGM Module (Bus Clock = CGMOUT Divided by Two)
IAB	Internal Address Bus
IDB	Internal Data Bus
PORRST	Signal from the Power-On Reset Module to the SIM
IRST	Internal Reset Signal
R/W	Read/Write Signal

## 7.3 SIM Bus Clock Control and Generation

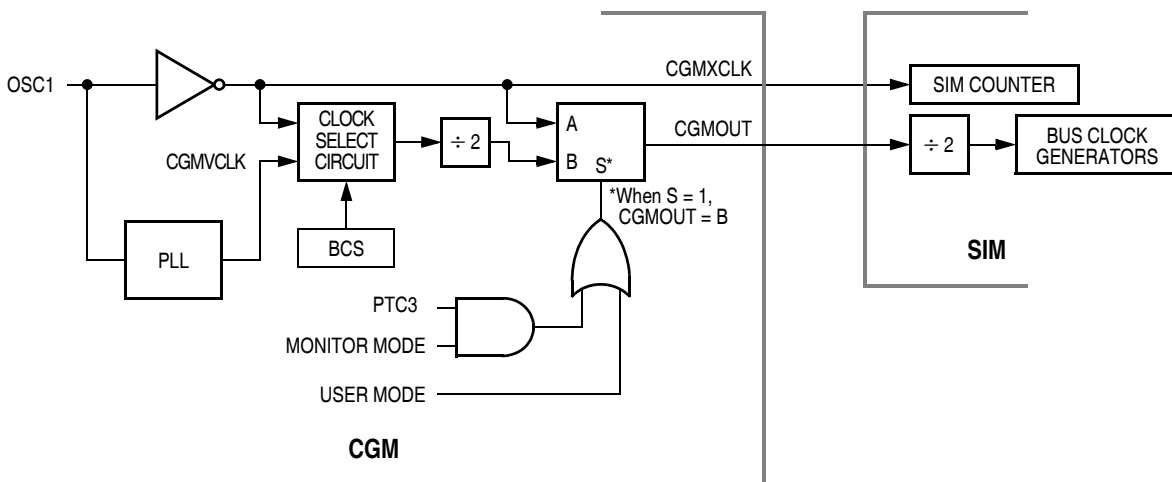
The bus clock generator provides system clock signals for the CPU and peripherals on the MCU. The system clocks are generated from an incoming clock, CGMOUT, as shown in [Figure 7-2](#). This clock can come from either an external oscillator or from the on-chip PLL. (See [Section 8. Clock Generator Module \(CGM\)](#).)

### 7.3.1 Bus Timing

In user mode, the internal bus frequency is either the crystal oscillator output (CGMXCLK) divided by four or the PLL output (CGMVCLK) divided by four. (See [Section 8. Clock Generator Module \(CGM\)](#).)

### 7.3.2 Clock Startup from POR or LVI Reset

When the power-on reset module or the low-voltage inhibit module generates a reset, the clocks to the CPU and peripherals are inactive and held in an inactive phase until after 4096 CGMXCLK cycles. The  $\overline{RST}$  pin is driven low by the SIM during this entire period. The bus clocks start upon completion of the timeout.



**Figure 7-2. CGM Clock Signals**

### 7.3.3 Clocks in Stop Mode and Wait Mode

Upon exit from stop mode by an interrupt, break, or reset, the SIM allows CGMXCLK to clock the SIM counter. The CPU and peripheral clocks do not become active until after the stop delay timeout. This timeout is selectable as 4096 or 32 CGMXCLK cycles. (See [7.7.2 Stop Mode](#).)

In wait mode, the CPU clocks are inactive. Refer to the wait mode subsection of each module to see if the module is active or inactive in wait mode. Some modules can be programmed to be active in wait mode.

## 7.4 Reset and System Initialization

The MCU has these reset sources:

- Power-on reset module (POR)
- External reset pin ( $\overline{\text{RST}}$ )
- Computer operating properly module (COP)
- Low-voltage inhibit module (LVI)
- Illegal opcode
- Illegal address

All of these resets produce the vector \$FFFE–FFFF (\$FEFE–FEFF in monitor mode) and assert the internal reset signal (IRST). IRST causes all registers to be returned to their default values and all modules to be returned to their reset states.

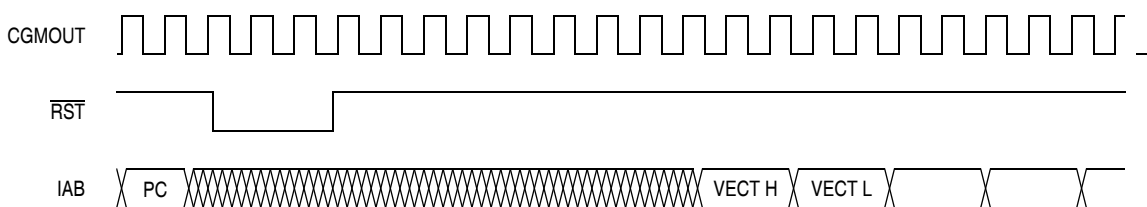
An internal reset clears the SIM counter (see [7.5 SIM Counter](#)), but an external reset does not. Each of the resets sets a corresponding bit in the SIM reset status register (SRSR). (See [7.8 SIM Registers](#).)

## 7.4.1 External Pin Reset

Pulling the asynchronous  $\overline{\text{RST}}$  pin low halts all processing. The PIN bit of the SIM reset status register (SRSR) is set as long as  $\overline{\text{RST}}$  is held low for a minimum of 67 CGMXCLK cycles, assuming that neither the POR nor the LVI was the source of the reset. See [Table 7-4](#) for details. [Figure 7-3](#) shows the relative timing.

**Table 7-4. PIN Bit Set Timing**

Reset Type	Number of Cycles Required to Set PIN
POR/LVI	4163 (4096 + 64 + 3)
All others	67 (64 + 3)



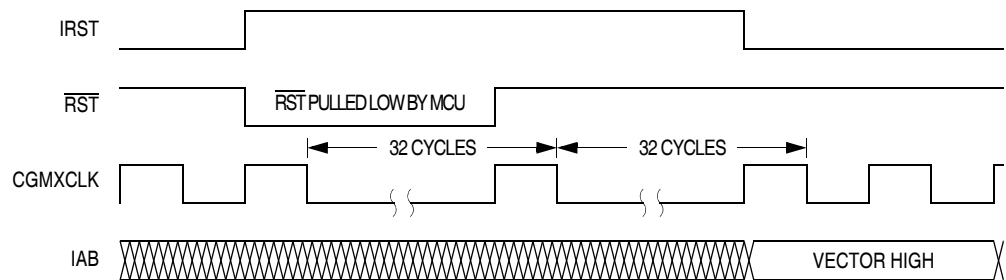
**Figure 7-3. External Reset Timing**

### 7.4.2 Active Resets from Internal Sources

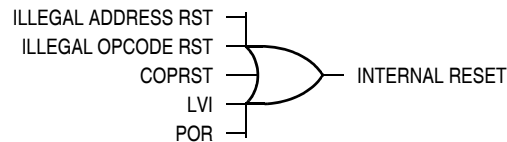
All internal reset sources actively pull the  $\overline{\text{RST}}$  pin low for 32 CGMXCLK cycles to allow resetting of external peripherals. The internal reset signal IRST continues to be asserted for an additional 32 cycles. See [Figure 7-4](#). An internal reset can be caused by an illegal address, illegal opcode, COP timeout, LVI, or POR. (See [Figure 7-5](#).) Note that for LVI or POR resets, the SIM cycles through 4096 CGMXCLK cycles during which the SIM forces the  $\overline{\text{RST}}$  pin low. The internal reset signal then follows the sequence from the falling edge of  $\overline{\text{RST}}$  shown in [Figure 7-4](#).

The COP reset is asynchronous to the bus clock.

The active reset feature allows the part to issue a reset to peripherals and other chips within a system built around the MCU.



**Figure 7-4. Internal Reset Timing**



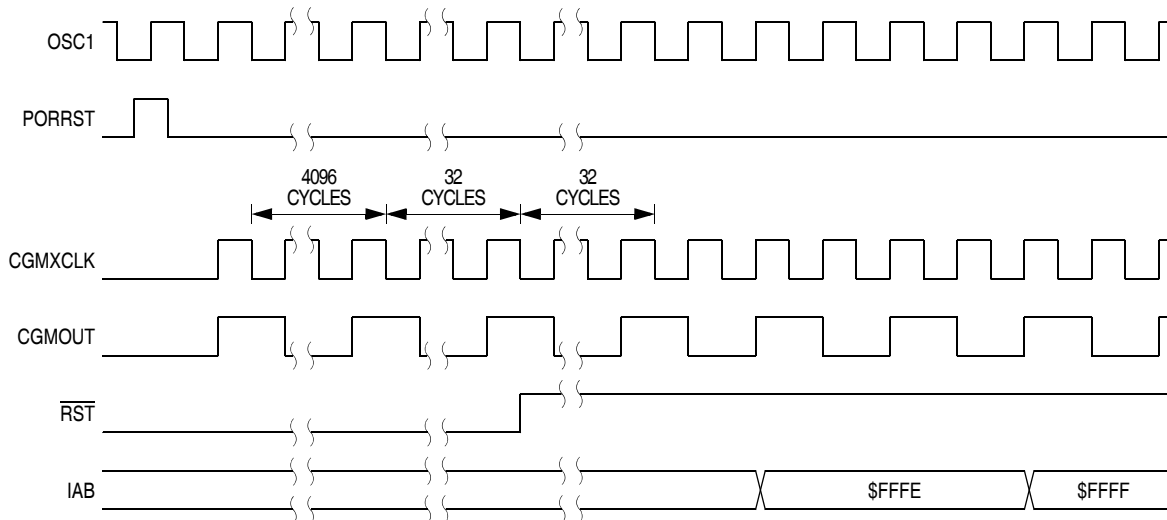
**Figure 7-5. Sources of Internal Reset**

## 7.4.2.1 Power-On Reset

When power is first applied to the MCU, the power-on reset module (POR) generates a pulse to indicate that power-on has occurred. The external reset pin ( $\overline{\text{RST}}$ ) is held low while the SIM counter counts out 4096 CGMXCLK cycles. Another sixty-four CGMXCLK cycles later, the CPU and memories are released from reset to allow the reset vector sequence to occur.

At power-on, the following events occur:

- A POR pulse is generated.
- The internal reset signal is asserted.
- The SIM enables CGMOUT.
- Internal clocks to the CPU and modules are held inactive for 4096 CGMXCLK cycles to allow stabilization of the oscillator.
- The  $\overline{\text{RST}}$  pin is driven low during the oscillator stabilization time.
- The POR bit of the SIM reset status register (SRSR) is set and all other bits in the register are cleared.



**Figure 7-6. POR Recovery**



#### 7.4.2.2 Computer Operating Properly (COP) Reset

The overflow of the COP counter causes an internal reset and sets the COP bit in the SIM reset status register (SRSR) if the COPD bit in the CONFIG-1 register is at logic zero. (See [Section 13. Computer Operating Properly Module \(COP\)](#).)

#### 7.4.2.3 Illegal Opcode Reset

The SIM decodes signals from the CPU to detect illegal instructions. An illegal instruction sets the ILOP bit in the SIM reset status register (SRSR) and causes a reset.

If the stop enable bit, STOP, in the CONFIG-1 register is logic zero, the SIM treats the STOP instruction as an illegal opcode and causes an illegal opcode reset.

#### 7.4.2.4 Illegal Address Reset

An opcode fetch from an unmapped address generates an illegal address reset. The SIM verifies that the CPU is fetching an opcode prior to asserting the ILAD bit in the SIM reset status register (SRSR) and resetting the MCU. A data fetch from an unmapped address does not generate a reset.

#### 7.4.2.5 Low-Voltage Inhibit (LVI) Reset

The low-voltage inhibit module (LVI) asserts its output to the SIM when the  $V_{DD}$  voltage falls to the  $V_{LVII}$  voltage. The LVI bit in the SIM reset status register (SRSR) is set and a chip reset is asserted if the LVIPWRD and LVIRSTD bits in the CONFIG-1 register are at logic zero. The  $\overline{RST}$  pin will be held low until the SIM counts 4096 CGMXCLK cycles after  $V_{DD}$  rises above  $V_{LVIR}$ . Another sixty-four CGMXCLK cycles later, the CPU is released from reset to allow the reset vector sequence to occur. (See [Section 14. Low-Voltage Inhibit \(LVI\)](#).)

## 7.5 SIM Counter

The SIM counter is used by the power-on reset module (POR) and in stop mode recovery to allow the oscillator time to stabilize before enabling the internal bus (IBUS) clocks. The SIM counter also serves as a prescaler for the computer operating properly module (COP). The SIM counter overflow supplies the clock for the COP module. The SIM counter is 12 bits long and is clocked by the falling edge of CGMXCLK.

### 7.5.1 SIM Counter During Power-On Reset

The power-on reset module (POR) detects power applied to the MCU. At power-on, the POR circuit asserts the signal PORRST. Once the SIM is initialized, it enables the clock generation module (CGM) to drive the bus clock state machine.

### 7.5.2 SIM Counter During Stop Mode Recovery

The SIM counter also is used for stop mode recovery. The STOP instruction clears the SIM counter. After an interrupt, break, or reset, the SIM senses the state of the short stop recovery bit, SSREC, in the CONFIG-1 register. If the SSREC bit is a logic one, then the stop recovery is reduced from the normal delay of 4096 CGMXCLK cycles down to 32 CGMXCLK cycles. This is ideal for applications using canned oscillators that do not require long start-up times from stop mode. External crystal applications should use the full stop recovery time, that is, with SSREC cleared.

### 7.5.3 SIM Counter and Reset States

External reset has no effect on the SIM counter. (See [7.7.2 Stop Mode](#) for details.) The SIM counter is free-running after all reset states. (See [7.4.2 Active Resets from Internal Sources](#) for counter control and internal reset recovery sequences.)

## 7.6 Program Exception Control

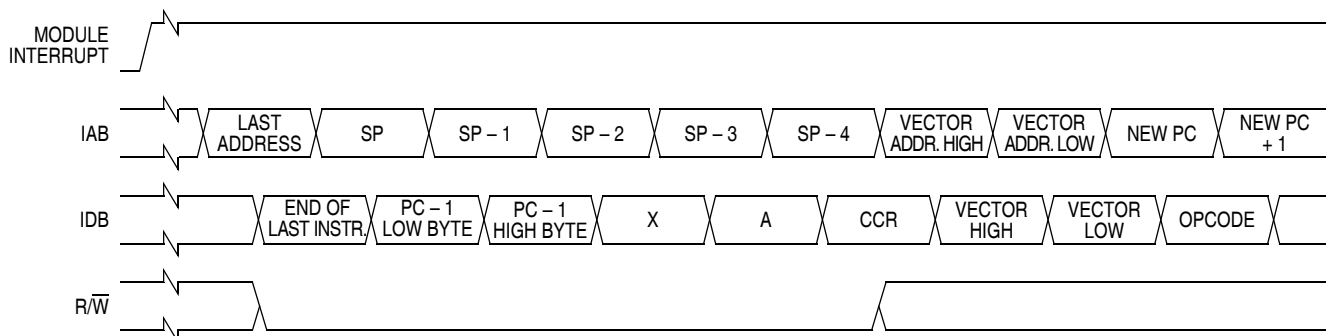
Normal, sequential program execution can be changed in three different ways:

- Interrupts
  - Maskable hardware CPU interrupts
  - Non-maskable software interrupt instruction (SWI)
- Reset
- Break interrupts

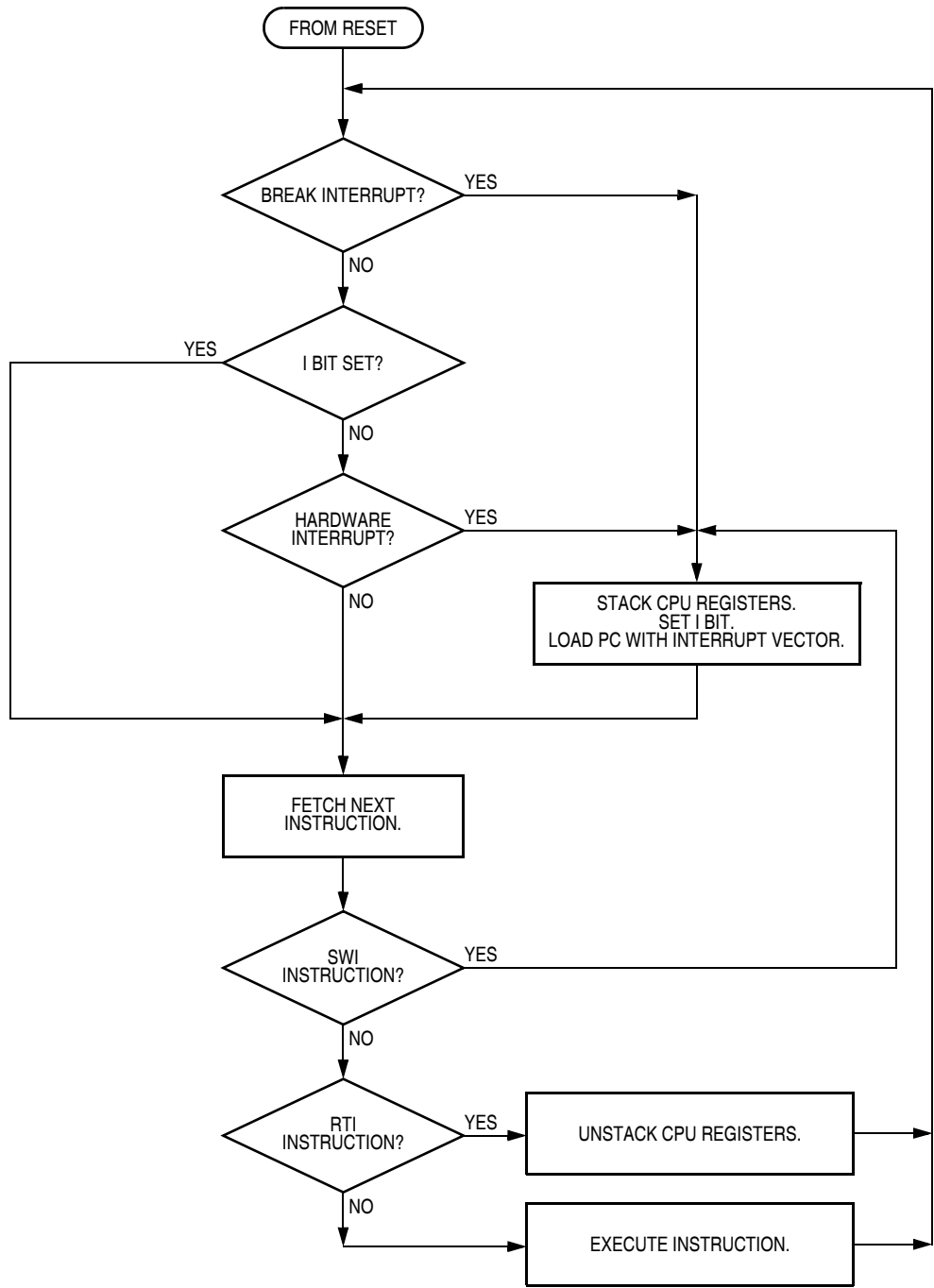
### 7.6.1 Interrupts

At the beginning of an interrupt, the CPU saves the CPU register contents on the stack and sets the interrupt mask (I bit) to prevent additional interrupts. At the end of an interrupt, the RTI instruction recovers the CPU register contents from the stack so that normal processing can resume. [Figure 7-7](#) shows interrupt entry timing. [Figure 7-9](#) shows interrupt recovery timing.

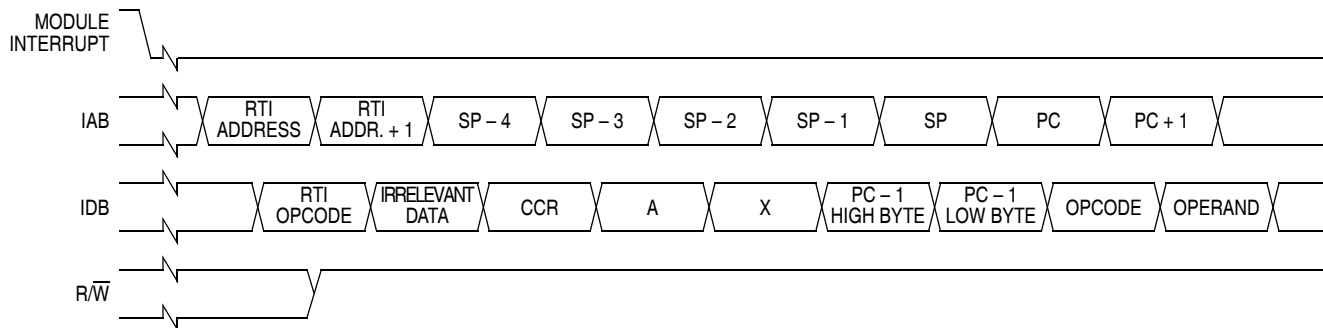
Interrupts are latched, and arbitration is performed in the SIM at the start of interrupt processing. The arbitration result is a constant that the CPU uses to determine which vector to fetch. Once an interrupt is latched by the SIM, no other interrupt can take precedence, regardless of priority, until the latched interrupt is serviced (or the I bit is cleared). (See [Figure 7-8](#).)



**Figure 7-7. Interrupt Entry Timing**



**Figure 7-8. Interrupt Processing**



**Figure 7-9. Interrupt Recovery Timing**

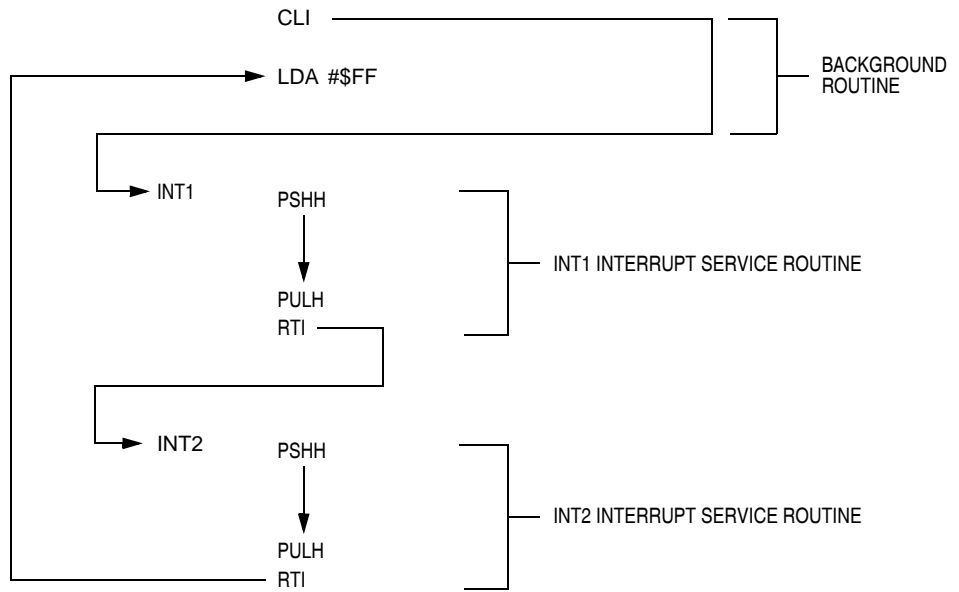
### Hardware Interrupts

A hardware interrupt does not stop the current instruction. Processing of a hardware interrupt begins after completion of the current instruction. When the current instruction is complete, the SIM checks all pending hardware interrupts. If interrupts are not masked (I bit clear in the condition code register), and if the corresponding interrupt enable bit is set, the SIM proceeds with interrupt processing; otherwise, the next instruction is fetched and executed.

If more than one interrupt is pending at the end of an instruction execution, the highest priority interrupt is serviced first. **Figure 7-10** demonstrates what happens when two interrupts are pending. If an interrupt is pending upon exit from the original interrupt service routine, the pending interrupt is serviced before the LDA instruction is executed.

The LDA opcode is prefetched by both the INT1 and INT2 RTI instructions. However, in the case of the INT1 RTI prefetch, this is a redundant operation.

**NOTE:** *To maintain compatibility with the M68HC05, M6805 and M146805 Families the H register is not pushed on the stack during interrupt entry. If the interrupt service routine modifies the H register or uses the indexed addressing mode, software should save the H register and then restore it prior to exiting the routine.*



**Figure 7-10. Interrupt Recognition Example**

### SWI Instruction

The SWI instruction is a non-maskable instruction that causes an interrupt regardless of the state of the interrupt mask (I bit) in the condition code register.

**NOTE:** *A software interrupt pushes PC onto the stack. A software interrupt does **not** push PC – 1, as a hardware interrupt does.*

## 7.6.2 Reset

All reset sources always have higher priority than interrupts and cannot be arbitrated.

## 7.6.3 Break Interrupts

The break module can stop normal program flow at a software-programmable break point by asserting its break interrupt output. (See [Section 11. Break Module \(BRK\)](#).) The SIM puts the CPU into the break state by forcing it to the SWI vector location. Refer to the break interrupt subsection of each module to see how each module is affected by the break state.

## 7.6.4 Status Flag Protection in Break Mode

The SIM controls whether status flags contained in other modules can be cleared during break mode. The user can select whether flags are protected from being cleared by properly initializing the break clear flag enable bit (BCFE) in the SIM break flag control register (SBFCR).

Protecting flags in break mode ensures that set flags will not be cleared while in break mode. This protection allows registers to be freely read and written during break mode without losing status flag information.

Setting the BCFE bit enables the clearing mechanisms. Once cleared in break mode, a flag remains cleared even when break mode is exited. Status flags with a two-step clearing mechanism — for example, a read of one register followed by the read or write of another — are protected, even when the first step is accomplished prior to entering break mode. Upon leaving break mode, execution of the second step will clear the flag as normal.

## 7.7 Low-Power Modes

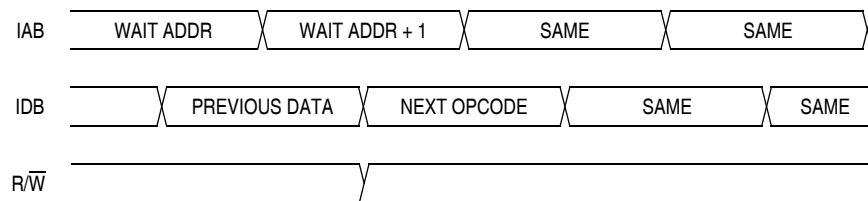
Executing the WAIT or STOP instruction puts the MCU in a low-power mode for standby situations. The SIM holds the CPU in a non-clocked state. The operation of each of these modes is described below. Both STOP and WAIT clear the interrupt mask (I) in the condition code register, allowing interrupts to occur.

### 7.7.1 Wait Mode

In wait mode, the CPU clocks are inactive while one set of peripheral clocks continue to run. **Figure 7-11** shows the timing for wait mode entry.

A module that is active during wait mode can wake up the CPU with an interrupt if the interrupt is enabled. Stacking for the interrupt begins one cycle after the WAIT instruction during which the interrupt occurred. Refer to the wait mode subsection of each module to see if the module is active or inactive in wait mode. Some modules can be programmed to be active in wait mode.

Wait mode can also be exited by a reset or break. A break interrupt during wait mode sets the SIM break stop/wait bit, SBSW, in the SIM break status register (SBSR). If the COP disable bit, COPD, in the configuration register is logic 0, then the computer operating properly module (COP) is enabled and remains active in wait mode.

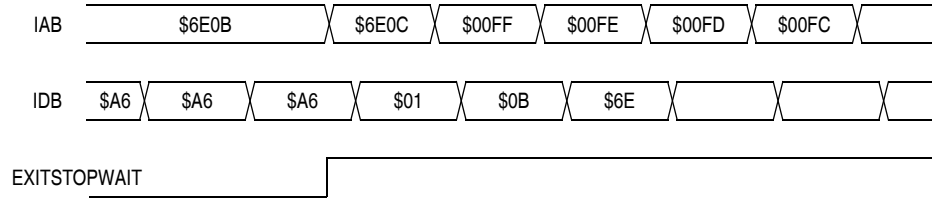


NOTE: Previous data can be operand data or the WAIT opcode, depending on the last instruction.

**Figure 7-11. Wait Mode Entry Timing**

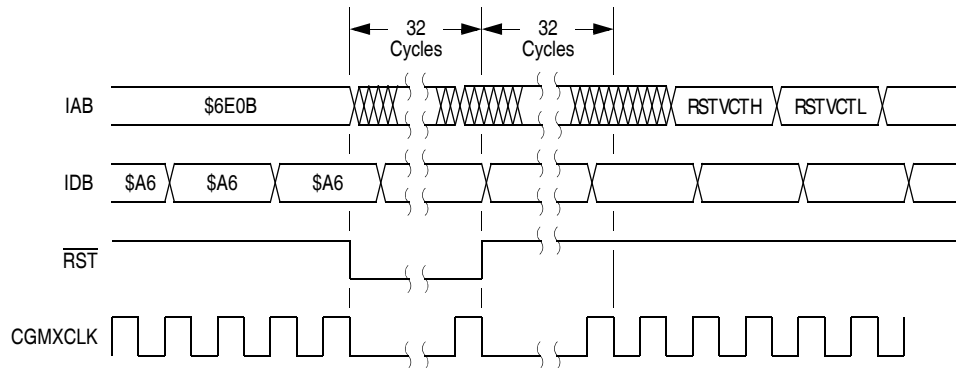


Figure 7-12 and Figure 7-13 show the timing for WAIT recovery.



NOTE: EXITSTOPWAIT =  $\overline{\text{RST}}$  pin OR CPU interrupt OR break interrupt

**Figure 7-12. Wait Recovery from Interrupt or Break**



**Figure 7-13. Wait Recovery from Internal Reset**

## 7.7.2 Stop Mode

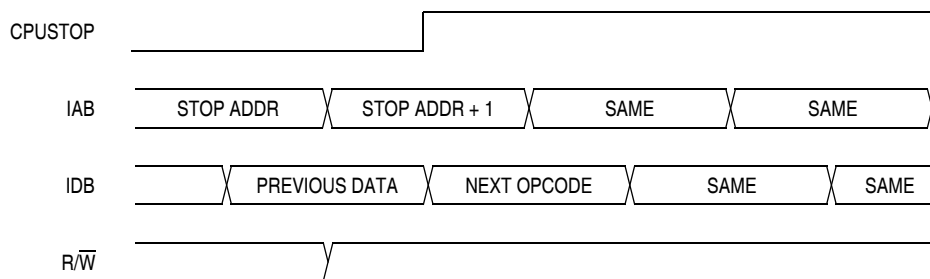
In stop mode, the SIM counter is reset and the system clocks are disabled. An interrupt request from a module can cause an exit from stop mode. Stacking for interrupts begins after the selected stop recovery time has elapsed. Reset or break also causes an exit from stop mode.

The SIM disables the clock generator module outputs (CGMOUT and CGMXCLK) in stop mode, stopping the CPU and peripherals. Stop recovery time is selectable using the SSREC bit in the configuration register (CONFIG-1). If SSREC is set, stop recovery is reduced from the normal delay of 4096 CGMXCLK cycles down to 32. This is ideal for applications using canned oscillators that do not require long startup times from stop mode.

**NOTE:** *External crystal applications should use the full stop recovery time by clearing the SSREC bit.*

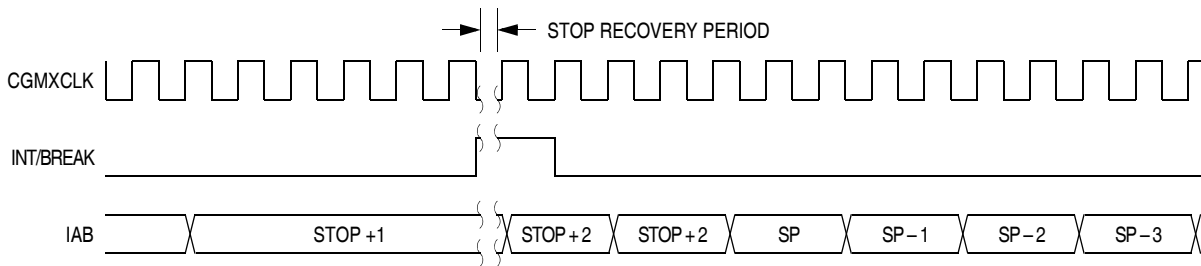
A break interrupt during stop mode sets the SIM break stop/wait bit (SBSW) in the SIM break status register (SBSR).

The SIM counter is held in reset from the execution of the STOP instruction until the beginning of stop recovery. It is then used to time the recovery period. [Figure 7-14](#) shows stop mode entry timing.



NOTE: Previous data can be operand data or the STOP opcode, depending on the last instruction.

**Figure 7-14. Stop Mode Entry Timing**



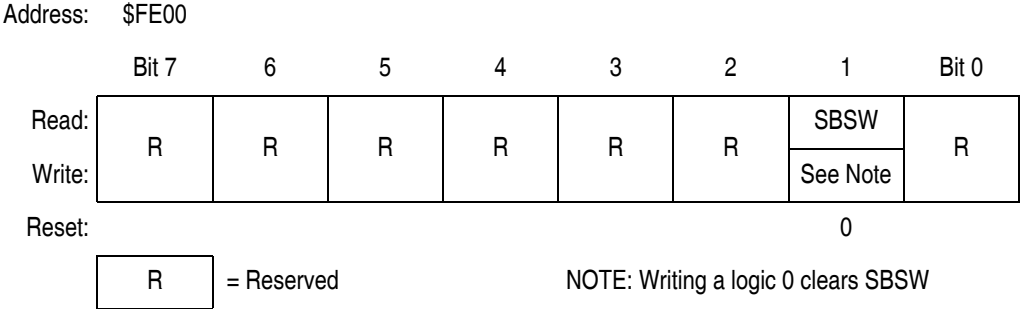
**Figure 7-15. Stop Mode Recovery from Interrupt or Break**

## 7.8 SIM Registers

The SIM has three memory mapped registers.

### 7.8.1 SIM Break Status Register

The SIM break status register contains a flag to indicate that a break caused an exit from stop or wait mode.



**Figure 7-16. SIM Break Status Register (SBSR)**

#### SBSW — SIM Break Stop/Wait

This status bit is useful in applications requiring a return to wait or stop mode after exiting from a break interrupt. Clear SBSW by writing a logic 0 to it. Reset clears SBSW.

- 1 = Stop mode or wait mode was exited by break interrupt
- 0 = Stop mode or wait mode was not exited by break interrupt

SBSW can be read within the break state SWI routine. The user can modify the return address on the stack by subtracting one from it. The following code is an example of this. Writing zero to the SBSW bit clears it.

```

; This code works if the H register has been pushed onto the stack in the break
; service routine software. This code should be executed at the end of the
; break service routine software.

HIBYTE EQU 5

LOBYTE EQU 6

; If not SBSW, do RTI
BRCLR SBSW,SBSR, RETURN ; See if wait mode or stop mode was exited
; by break.

TST LOBYTE,SP ; If RETURNLO is not zero,
BNE DOLO ; then just decrement low byte.
DEC HIBYTE,SP ; Else deal with high byte, too.
DOLO DEC LOBYTE,SP ; Point to WAIT/STOP opcode.
RETURN PULH ; Restore H register.
RTI

```

## 7.8.2 SIM Reset Status Register


This read-only register contains flags to show reset sources. A power-on reset sets the POR flag and clears all other flags. Reset sources other than power-on reset do not clear all other flags.

Reading the reset status register clears all reset flags. Reset service can read the reset status register to clear the register after power-on reset and to determine the source of any subsequent reset.

**NOTE:** *Only a read of the reset status register clears all reset flags. After multiple resets from different sources without reading the register, multiple flags remain set.*

Address: \$FE01

	Bit 7	6	5	4	3	2	1	Bit 0
Read:	POR	PIN	COP	ILOP	ILAD	0	LVI	0
Write:								
Reset:	1	X	0	0	0	0	X	0

 = Unimplemented    X = Indeterminate

**Figure 7-17. SIM Reset Status Register (SRSR)**

POR — Power-On Reset Flag

- 1 = Power-on reset since last read of RSR
- 0 = Read of RSR since last power-on reset

PIN — External Reset Flag

- 1 = External reset since last read of RSR
- 0 = Power-on reset or read of RSR since last external reset

COP — COP Reset Flag

- 1 = COP reset since last read of RSR
- 0 = Power-on reset or read of RSR since last COP reset

ILOP — Illegal Opcode Reset Flag

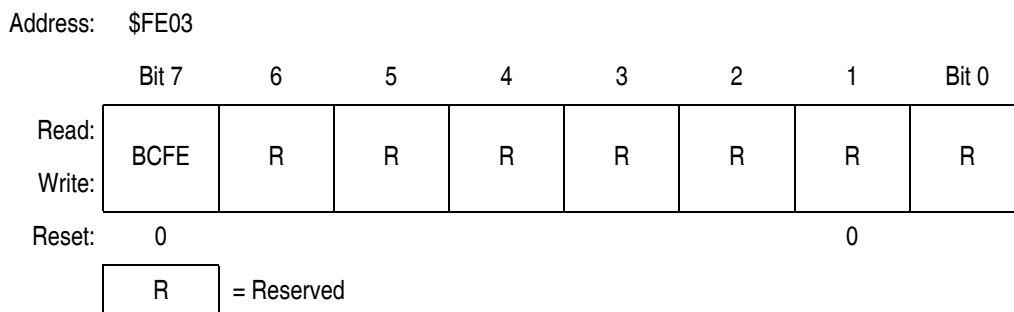
- 1 = Illegal opcode reset since last read of RSR
- 0 = Power-on reset or read of RSR since last illegal opcode reset

ILAD — Illegal Address Reset Flag  
 1 = Illegal address reset since last read of RSR  
 0 = Power-on reset or read of RSR since last illegal address reset

LVI — Low-Voltage Inhibit Reset Flag  
 1 = LVI reset since last read of RSR  
 0 = Power-on reset or read of RSR since last LVI reset

### 7.8.3 SIM Break Flag Control Register

The SIM break control register contains a bit that enables software to clear status bits while the MCU is in a break state.



**Figure 7-18. SIM Break Flag Control Register (SBFCR)**

BCFE — Break Clear Flag Enable Bit

This read/write bit enables software to clear status bits by accessing status registers while the MCU is in a break state. To clear status bits during the break state, the BCFE bit must be set.

- 1 = Status bits clearable during break
- 0 = Status bits not clearable during break

## Section 8. Clock Generator Module (CGM)

### 8.1 Contents

8.2	Introduction	140
8.3	Features	140
8.4	Functional Description	141
8.4.1	Crystal Oscillator Circuit	141
8.4.2	Phase-Locked Loop Circuit (PLL)	144
8.4.2.1	Circuits	144
8.4.2.2	Acquisition and Tracking Modes	145
8.4.2.3	Manual and Automatic PLL Bandwidth Modes	145
8.4.2.4	Programming the PLL	147
8.4.2.5	Special Programming Exceptions	149
8.4.3	Base Clock Selector Circuit	149
8.4.4	CGM External Connections	150
8.5	I/O Signals	151
8.5.1	Crystal Amplifier Input Pin (OSC1)	151
8.5.2	Crystal Amplifier Output Pin (OSC2)	151
8.5.3	External Filter Capacitor Pin (CGMXFC)	151
8.5.4	Analog Power Pin ( $V_{DDA}$ )	152
8.5.5	Oscillator Enable Signal (SIMOSCEN)	152
8.5.6	Crystal Output Frequency Signal (CGMXCLK)	152
8.5.7	CGM Base Clock Output (CGMOUT)	152
8.5.8	CGM CPU Interrupt (CGMINT)	152
8.6	CGM Registers	153
8.6.1	PLL Control Register	153
8.6.2	PLL Bandwidth Control Register	155
8.6.3	PLL Programming Register	157
8.7	Interrupts	159
8.8	Low-Power Modes	159

8.8.1	Wait Mode . . . . .	159
8.8.2	Stop Mode . . . . .	160
8.9	CGM During Break Interrupts . . . . .	160
8.10	Acquisition/Lock Time Specifications . . . . .	160
8.10.1	Acquisition/Lock Time Definitions . . . . .	161
8.10.2	Parametric Influences on Reaction Time . . . . .	162
8.10.3	Choosing a Filter Capacitor . . . . .	163
8.10.4	Reaction Time Calculation . . . . .	164

## 8.2 Introduction

The CGM generates the crystal clock signal, CGMXCLK, which operates at the frequency of the crystal. The CGM also generates the base clock signal, CGMOUT, from which the system clocks are derived. CGMOUT is based on either the crystal clock divided by two or the phase-locked loop (PLL) clock, CGMVCLK, divided by two. The PLL is a frequency generator designed for use with 1-MHz to 16-MHz crystals or ceramic resonators. The PLL can generate an 8-MHz bus frequency without using a 32-MHz crystal.

## 8.3 Features

Features of the CGM include:

- Phase-Locked Loop with Output Frequency in Integer Multiples of the Crystal Reference
- Programmable Hardware Voltage-Controlled Oscillator (VCO) for Low-Jitter Operation
- Automatic Bandwidth Control Mode for Low-Jitter Operation
- Automatic Frequency Lock Detector
- CPU Interrupt on Entry or Exit from Locked Condition



## 8.4 Functional Description

The CGM consists of three major submodules:

- Crystal oscillator circuit — The crystal oscillator circuit generates the constant crystal frequency clock, CGMXCLK.
- Phase-locked loop (PLL) — The PLL generates the programmable VCO frequency clock CGMVCLK.
- Base clock selector circuit — This software-controlled circuit selects either CGMXCLK divided by two or the VCO clock, CGMVCLK, divided by two as the base clock, CGMOUT. The system clocks are derived from CGMOUT.

**Figure 8-1** shows the structure of the CGM.

### 8.4.1 Crystal Oscillator Circuit

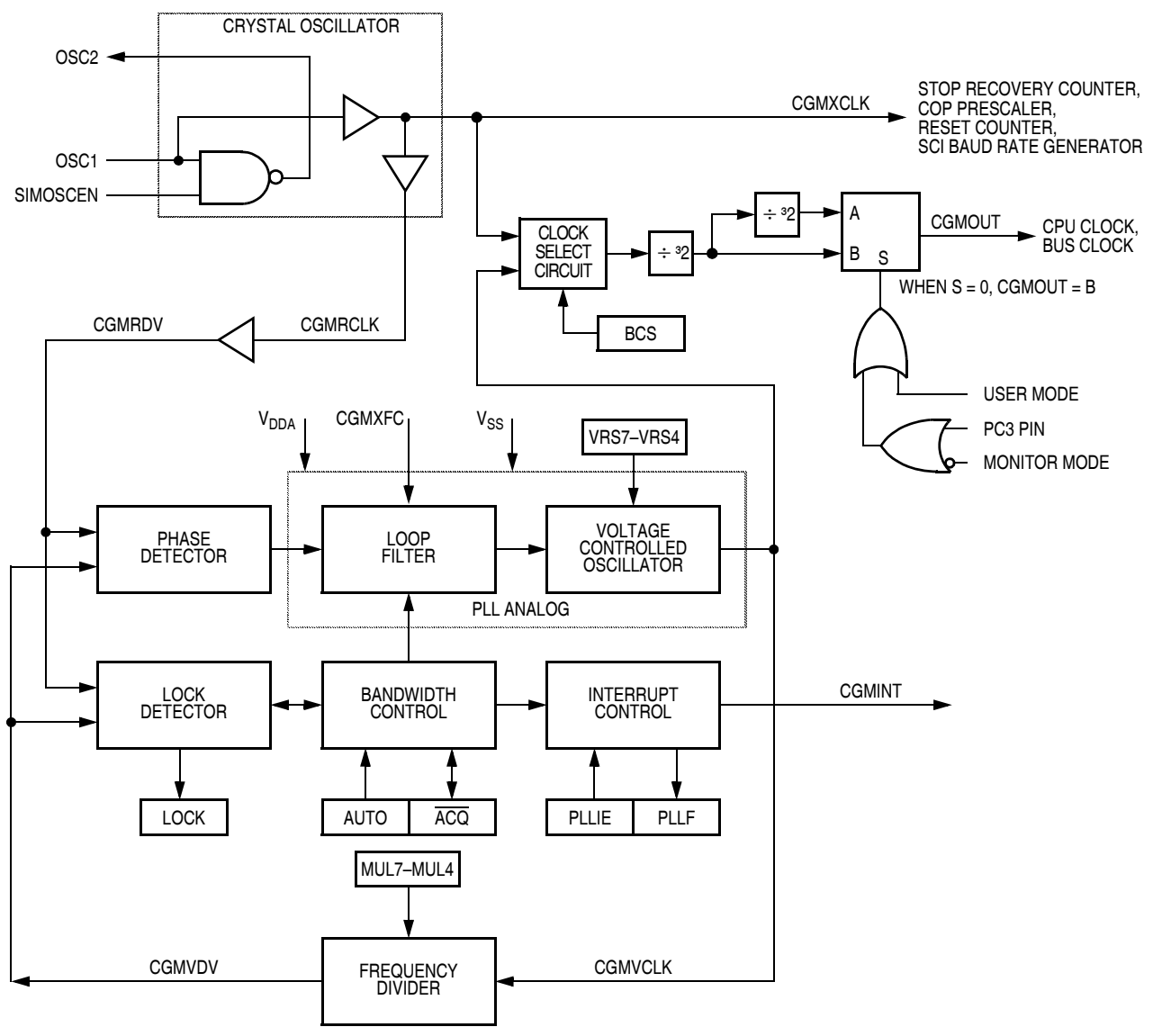
The crystal oscillator circuit consists of an inverting amplifier and an external crystal. The OSC1 pin is the input to the amplifier and the OSC2 pin is the output. The SIMOSCEN signal enables the crystal oscillator circuit.

The CGMXCLK signal is the output of the crystal oscillator circuit and runs at a rate equal to the crystal frequency. CGMXCLK is then buffered to produce CGMRCLK, the PLL reference clock.

CGMXCLK can be used by other modules which require precise timing for operation. The duty cycle of CGMXCLK is not guaranteed to be 50% and depends on external factors, including the crystal and related external components.

An externally generated clock also can feed the OSC1 pin of the crystal oscillator circuit. Connect the external clock to the OSC1 pin and let the OSC2 pin float.

# Clock Generator Module (CGM)



**Figure 8-1. CGM Block Diagram**



# Clock Generator Module (CGM)

**Table 8-1. I/O Register Summary**

Addr.	Register Name	Bit 7	6	5	4	3	2	1	Bit 0	
\$001C	PLL Control Register (PCTL)	Read:	PLLIE	PLLF	PLLON	BCS	1	1	1	1
		Write:								
		Reset:	0	0	1	0	1	1	1	1
\$001D	PLL Bandwidth Control Register (PBWC)	Read:	AUTO	LOCK	$\overline{ACQ}$	XLD	0	0	0	0
		Write:								
		Reset:	0	0	0	0	0	0	0	0
\$001E	PLL Programming Register (PPG)	Read:	MUL7	MUL6	MUL5	MUL4	VRS7	VRS6	VRS5	VRS4
		Write:								
		Reset:	0	1	1	0	0	1	1	0

= Unimplemented

**Table 8-2. I/O Register Address Summary**

<b>Register</b>	PCTL	PBWC	PPG
<b>Address</b>	\$001C	\$001D	\$001E

## 8.4.2 Phase-Locked Loop Circuit (PLL)

The PLL is a frequency generator that can operate in either acquisition mode or tracking mode, depending on the accuracy of the output frequency. The PLL can change between acquisition and tracking modes either automatically or manually.

### 8.4.2.1 Circuits

The PLL consists of these circuits:

- Voltage-controlled oscillator (VCO)
- Modulo VCO frequency divider
- Phase detector
- Loop filter
- Lock detector

The operating range of the VCO is programmable for a wide range of frequencies and for maximum immunity to external noise, including supply and CGMXFC noise. The VCO frequency is bound to a range from roughly one-half to twice the center-of-range frequency,  $f_{VRS}$ . Modulating the voltage on the CGMXFC pin changes the frequency within this range. By design,  $f_{VRS}$  is equal to the nominal center-of-range frequency,  $f_{NOM}$ , (4.9152 MHz) times a linear factor  $L$  or  $(L)f_{NOM}$ .

CGMRCLK is the PLL reference clock, a buffered version of CGMXCLK. CGMRCLK runs at a frequency,  $f_{RCLK}$ , and is fed to the PLL through a buffer. The buffer output is the final reference clock, CGMRDV, running at a frequency  $f_{RDV} = f_{RCLK}$ .

The VCO's output clock, CGMVCLK, running at a frequency  $f_{VCLK}$ , is fed back through a programmable modulo divider. The modulo divider reduces the VCO clock by a factor,  $N$ . The divider's output is the VCO feedback clock, CGMVDV, running at a frequency  $f_{VDV} = f_{VCLK}/N$ . See [8.4.2.4 Programming the PLL](#) for more information.

The phase detector then compares the VCO feedback clock, CGMVDV, with the final reference clock, CGMRDV. A correction pulse is generated based on the phase difference between the two signals. The loop filter

then slightly alters the dc voltage on the external capacitor connected to CGMXFC based on the width and direction of the correction pulse. The filter can make fast or slow corrections depending on its mode, described in [8.4.2.2 Acquisition and Tracking Modes](#). The value of the external capacitor and the reference frequency determines the speed of the corrections and the stability of the PLL.

The lock detector compares the frequencies of the VCO feedback clock, CGMVDV, and the final reference clock, CGMRDV. Therefore, the speed of the lock detector is directly proportional to the final reference frequency,  $f_{RDV}$ . The circuit determines the mode of the PLL and the lock condition based on this comparison.

#### 8.4.2.2 Acquisition and Tracking Modes

The PLL filter is manually or automatically configurable into one of two operating modes:

- Acquisition mode — In acquisition mode, the filter can make large frequency corrections to the VCO. This mode is used at PLL startup or when the PLL has suffered a severe noise hit and the VCO frequency is far off the desired frequency. When in acquisition mode, the  $\overline{ACQ}$  bit is clear in the PLL bandwidth control register. (See [8.6.2 PLL Bandwidth Control Register](#).)
- Tracking mode — In tracking mode, the filter makes only small corrections to the frequency of the VCO. PLL jitter is much lower in tracking mode, but the response to noise is also slower. The PLL enters tracking mode when the VCO frequency is nearly correct, such as when the PLL is selected as the base clock source. (See [8.4.3 Base Clock Selector Circuit](#).) The PLL is automatically in tracking mode when it's not in acquisition mode or when the  $\overline{ACQ}$  bit is set.

#### 8.4.2.3 Manual and Automatic PLL Bandwidth Modes

The PLL can change the bandwidth or operational mode of the loop filter manually or automatically.

In automatic bandwidth control mode (AUTO = 1), the lock detector automatically switches between acquisition and tracking modes. Automatic bandwidth control mode also is used to determine when the VCO clock, CGMVCLK, is safe to use as the source for the base clock, CGMOUT. (See [8.6.2 PLL Bandwidth Control Register](#).) If PLL CPU interrupt requests are enabled, the software can wait for a PLL CPU interrupt request and then check the LOCK bit. If CPU interrupts are disabled, software can poll the LOCK bit continuously (during PLL startup, usually) or at periodic intervals. In either case, when the LOCK bit is set, the VCO clock is safe to use as the source for the base clock. (See [8.4.3 Base Clock Selector Circuit](#).) If the VCO is selected as the source for the base clock and the LOCK bit is clear, the PLL has suffered a severe noise hit and the software must take appropriate action, depending on the application. (See [8.7 Interrupts](#).)

These conditions apply when the PLL is in automatic bandwidth control mode:

- The  $\overline{\text{ACQ}}$  bit (See [8.6.2 PLL Bandwidth Control Register](#).) is a read-only indicator of the mode of the filter. (See [8.4.2.2 Acquisition and Tracking Modes](#).)
- The  $\overline{\text{ACQ}}$  bit is set when the VCO frequency is within a certain tolerance,  $\Delta_{\text{trk}}$ , and is cleared when the VCO frequency is out of a certain tolerance,  $\Delta_{\text{unt}}$ . (See [Section 29. Electrical Specifications](#).)
- The LOCK bit is a read-only indicator of the locked state of the PLL.
- The LOCK bit is set when the VCO frequency is within a certain tolerance,  $\Delta_{\text{Lock}}$ , and is cleared when the VCO frequency is out of a certain tolerance,  $\Delta_{\text{unl}}$ . (See [Section 29. Electrical Specifications](#).)
- CPU interrupts can occur if enabled (PLLIE = 1) when the PLL's lock condition changes, toggling the LOCK bit. (See [8.6.1 PLL Control Register](#).)

The PLL also can operate in manual mode (AUTO = 0). Manual mode is used by systems that do not require an indicator of the lock condition for proper operation. Such systems typically operate well below  $f_{\text{busmax}}$  and

require fast startup. The following conditions apply when in manual mode:

- $\overline{ACQ}$  is a writable control bit that controls the mode of the filter. Before turning on the PLL in manual mode, the  $\overline{ACQ}$  bit must be clear.
- Before entering tracking mode ( $\overline{ACQ} = 1$ ), software must wait a given time,  $t_{acq}$  (See [Section 29. Electrical Specifications.](#)), after turning on the PLL by setting PLLON in the PLL control register (PCTL).
- Software must wait a given time,  $t_{al}$ , after entering tracking mode before selecting the PLL as the clock source to CGMOUT ( $BCS = 1$ ).
- The LOCK bit is disabled.
- CPU interrupts from the CGM are disabled.

### 8.4.2.4 Programming the PLL

Use this 3-step procedure to program the PLL.

1. Choose the desired bus frequency,  $f_{BUSDES}$ .  
Example:  $f_{BUSDES} = 8 \text{ MHz}$
2. Calculate the desired VCO frequency,  $f_{VCLKDES}$ .  
$$f_{VCLKDES} = 4 \times f_{BUSDES}$$
  
Example:  $f_{VCLKDES} = 4 \times 8 \text{ MHz} = 32 \text{ MHz}$
3. Using a reference frequency,  $f_{rclk}$ , equal to the crystal frequency, calculate the VCO frequency multiplier, N. Round the result to the nearest integer.

$$N = \frac{f_{vclkdes}}{f_{rclk}}$$

$$\text{Example: } N = \frac{32 \text{ MHz}}{4 \text{ MHz}} = 8$$

4. Calculate the VCO frequency,  $f_{vclk}$ .



$$f_{VCLK} = N \times f_{RCLK}$$

$$\text{Example: } f_{VCLK} = 8 \times 4 \text{ MHz} = 32 \text{ MHz}$$

5. Calculate the bus frequency,  $f_{bus}$ , and compare  $f_{bus}$  with  $f_{busdes}$ .

$$f_{bus} = \frac{f_{vclk}}{4}$$

$$\text{Example: } f_{bus} = \frac{32 \text{ MHz}}{4} = 8 \text{ MHz}$$

6. If the calculated  $f_{bus}$  is not within the tolerance limits of your application, select another  $f_{busdes}$  or another  $f_{rclk}$ .
7. Using the value 4.9152 MHz for  $f_{nom}$ , calculate the VCO linear range multiplier, L. The linear range multiplier controls the frequency range of the PLL.

$$L = \text{round}\left(\frac{f_{vclk}}{f_{nom}}\right)$$

$$\text{Example: } L = \frac{32 \text{ MHz}}{4.9152 \text{ MHz}} = 7$$

8. Calculate the VCO center-of-range frequency,  $f_{VRS}$ . The center-of-range frequency is the midpoint between the minimum and maximum frequencies attainable by the PLL.

$$f_{VRS} = L \times f_{NOM}$$

$$\text{Example: } f_{VRS} = 7 \times 4.9152 \text{ MHz} = 34.4 \text{ MHz}$$

**NOTE:** For proper operation,  $|f_{VRS} - f_{VCLK}| \leq \frac{f_{NOM}}{2}$ .

*Exceeding the recommended maximum bus frequency or VCO frequency can crash the MCU.*

9. Program the PLL registers accordingly:

- a. In the upper four bits of the PLL programming register (PPG), program the binary equivalent of N.
- b. In the lower four bits of the PLL programming register (PPG), program the binary equivalent of L.

#### 8.4.2.5 Special Programming Exceptions

The programming method described in [8.4.2.4 Programming the PLL](#) does not account for two possible exceptions. A value of 0 for N or L is meaningless when used in the equations given. To account for these exceptions:

- A 0 value for N is interpreted the same as a value of 1.
- A 0 value for L disables the PLL and prevents its selection as the source for the base clock. (See [8.4.3 Base Clock Selector Circuit](#).)

#### 8.4.3 Base Clock Selector Circuit

This circuit is used to select either the crystal clock, CGMXCLK, or the VCO clock, CGMVCLK, as the source of the base clock, CGMOUT. The two input clocks go through a transition control circuit that waits up to three CGMXCLK cycles and three CGMVCLK cycles to change from one clock source to the other. During this time, CGMOUT is held in stasis. The output of the transition control circuit is then divided by two to correct the duty cycle. Therefore, the bus clock frequency, which is one-half of the base clock frequency, is one-fourth the frequency of the selected clock (CGMXCLK or CGMVCLK).

The BCS bit in the PLL control register (PCTL) selects which clock drives CGMOUT. The VCO clock cannot be selected as the base clock source if the PLL is not turned on. The PLL cannot be turned off if the VCO clock is selected. The PLL cannot be turned on or off simultaneously with the selection or deselection of the VCO clock. The VCO clock also cannot be selected as the base clock source if the factor L is programmed to a 0. This value would set up a condition inconsistent with the operation of the PLL, so that the PLL would be disabled and the crystal clock would be forced as the source of the base clock.

#### 8.4.4 CGM External Connections

In its typical configuration, the CGM requires seven external components. Five of these are for the crystal oscillator and two are for the PLL.

The crystal oscillator is normally connected in a Pierce oscillator configuration, as shown in **Figure 8-2**. **Figure 8-2** shows only the logical representation of the internal components and may not represent actual circuitry. The oscillator configuration uses five components:

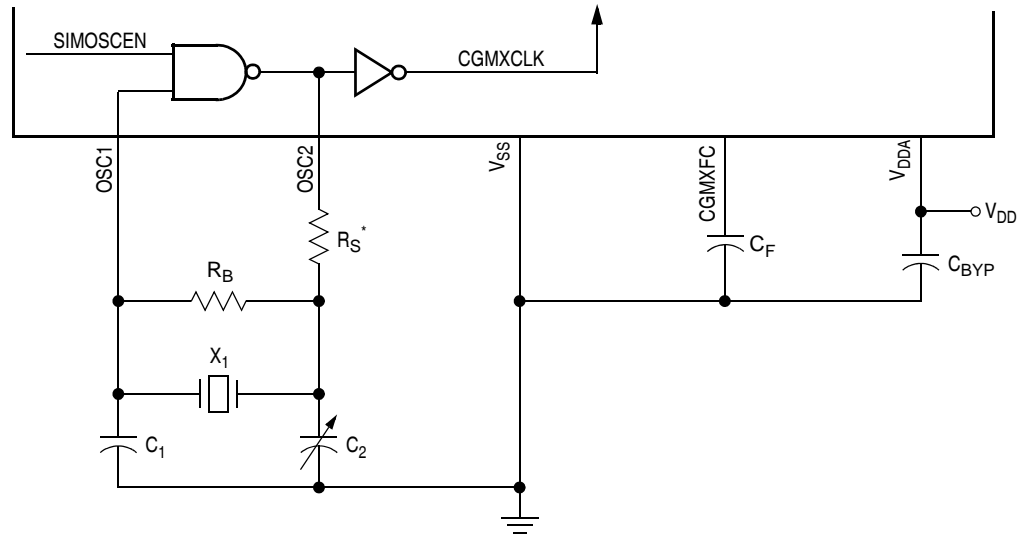
- Crystal,  $X_1$
- Fixed capacitor,  $C_1$
- Tuning capacitor,  $C_2$  (can also be a fixed capacitor)
- Feedback resistor,  $R_B$
- Series resistor,  $R_S$  (optional)

The series resistor ( $R_S$ ) may not be required for all ranges of operation, especially with high-frequency crystals. Refer to the crystal manufacturer's data for more information.

**Figure 8-2** also shows the external components for the PLL:

- Bypass capacitor,  $C_{byp}$
- Filter capacitor,  $C_F$

Routing should be done with great care to minimize signal cross talk and noise. (See **8.10 Acquisition/Lock Time Specifications** for routing information and more information on the filter capacitor's value and its effects on PLL performance.)



\* $R_S$  can be 0 (shorted) when used with higher-frequency crystals. Refer to manufacturer's data.

**Figure 8-2. CGM External Connections**

## 8.5 I/O Signals

The following paragraphs describe the CGM input/output (I/O) signals.

### 8.5.1 Crystal Amplifier Input Pin (OSC1)

The OSC1 pin is an input to the crystal oscillator amplifier.

### 8.5.2 Crystal Amplifier Output Pin (OSC2)

The OSC2 pin is the output of the crystal oscillator inverting amplifier.

### 8.5.3 External Filter Capacitor Pin (CGMXFC)

The CGMXFC pin is required by the loop filter to filter out phase corrections. A small external capacitor is connected to this pin.

**NOTE:** To prevent noise problems,  $C_F$  should be placed as close to the CGMXFC pin as possible with minimum routing distances and no routing of other signals across the  $C_F$  connection.

#### 8.5.4 Analog Power Pin ( $V_{DDA}$ )

$V_{DDA}$  is a power pin used by the analog portions of the PLL. Connect the  $V_{DDA}$  pin to the same voltage potential as the  $V_{DD}$  pin.

**NOTE:** Route  $V_{DDA}$  carefully for maximum noise immunity and place bypass capacitors as close as possible to the package.

#### 8.5.5 Oscillator Enable Signal (SIMOSCEN)

The SIMOSCEN signal enables the oscillator and PLL.

#### 8.5.6 Crystal Output Frequency Signal (CGMXCLK)

CGMXCLK is the crystal oscillator output signal. It runs at the full speed of the crystal ( $f_{xclk}$ ) and comes directly from the crystal oscillator circuit. [Figure 8-2](#) shows only the logical relation of CGMXCLK to OSC1 and OSC2 and may not represent the actual circuitry. The duty cycle of CGMXCLK is unknown and may depend on the crystal and other external factors. Also, the frequency and amplitude of CGMXCLK can be unstable at startup.

#### 8.5.7 CGM Base Clock Output (CGMOUT)

CGMOUT is the clock output of the CGM. This signal is used to generate the MCU clocks. CGMOUT is a 50% duty cycle clock running at twice the bus frequency. CGMOUT is software programmable to be either the oscillator output, CGMXCLK, divided by two or the VCO clock, CGMVCLK, divided by two.

#### 8.5.8 CGM CPU Interrupt (CGMINT)

CGMINT is the CPU interrupt signal generated by the PLL lock detector.

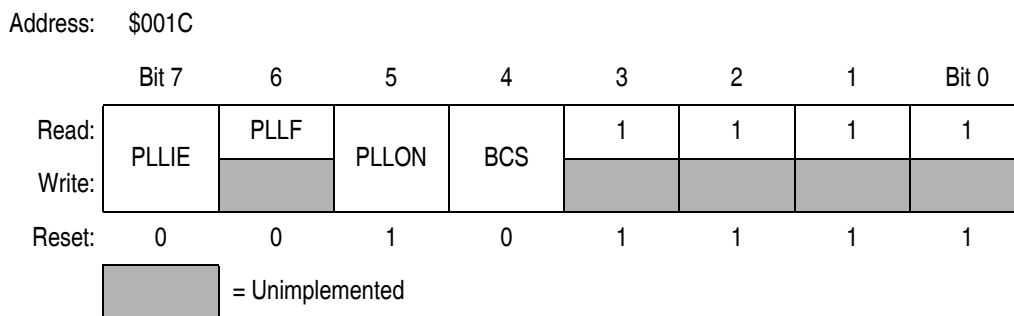
## 8.6 CGM Registers

Three registers control and monitor operation of the CGM:

- PLL control register (PCTL)
- PLL bandwidth control register (PBWC)
- PLL programming register (PPG)

### 8.6.1 PLL Control Register

The PLL control register contains the interrupt enable and flag bits, the on/off switch, and the base clock selector bit.



**Figure 8-3. PLL Control Register (PCTL)**

#### PLLIE — PLL Interrupt Enable Bit

This read/write bit enables the PLL to generate a CPU interrupt request when the LOCK bit toggles, setting the PLL flag, PLLF. When the AUTO bit in the PLL bandwidth control register (PBWC) is clear, PLLIE cannot be written and reads as logic 0. Reset clears the PLLIE bit.

- 1 = PLL CPU interrupt requests enabled
- 0 = PLL CPU interrupt requests disabled

### PLL F — PLL Flag Bit

This read-only bit is set whenever the LOCK bit toggles. PLL F generates a CPU interrupt request if the PLL IE bit also is set. PLL F always reads as logic 0 when the AUTO bit in the PLL bandwidth control register (PBWC) is clear. Clear the PLL F bit by reading the PLL control register. Reset clears the PLL F bit.

- 1 = Change in lock condition
- 0 = No change in lock condition

**NOTE:** *Do not inadvertently clear the PLL F bit. Be aware that any read or read-modify-write operation on the PLL control register clears the PLL F bit.*

### PLL ON — PLL On Bit

This read/write bit activates the PLL and enables the VCO clock, CGMVCLK. PLL ON cannot be cleared if the VCO clock is driving the base clock, CGMOUT (BCS = 1). (See [8.4.3 Base Clock Selector Circuit](#).) Reset sets this bit so that the loop can stabilize as the MCU is powering up.

- 1 = PLL on
- 0 = PLL off

### BCS — Base Clock Select Bit

This read/write bit selects either the crystal oscillator output, CGMXCLK, or the VCO clock, CGMVCLK, as the source of the CGM output, CGMOUT. CGMOUT frequency is one-half the frequency of the selected clock. BCS cannot be set while the PLL ON bit is clear. After toggling BCS, it may take up to three CGMXCLK and three CGMVCLK cycles to complete the transition from one source clock to the other. During the transition, CGMOUT is held in stasis. (See [8.4.3 Base Clock Selector Circuit](#).) Reset and the STOP instruction clear the BCS bit.

- 1 = CGMVCLK divided by two drives CGMOUT
- 0 = CGMXCLK divided by two drives CGMOUT

**NOTE:** *PLLON and BCS have built-in protection that prevents the base clock selector circuit from selecting the VCO clock as the source of the base clock if the PLL is off. Therefore, PLLON cannot be cleared when BCS is set, and BCS cannot be set when PLLON is clear. If the PLL is off (PLLON=0), selecting CGMVCLK requires two writes to the PLL control register. (See [8.4.3 Base Clock Selector Circuit](#).)*

PCTL3–PCTL — Unimplemented

These bits provide no function and always read as logic 1s.


## 8.6.2 PLL Bandwidth Control Register

The PLL bandwidth control register:

- Selects automatic or manual (software-controlled) bandwidth control mode
- Indicates when the PLL is locked
- In automatic bandwidth control mode, indicates when the PLL is in acquisition or tracking mode
- In manual operation, forces the PLL into acquisition or tracking mode

Address: \$001D

	Bit 7	6	5	4	3	2	1	Bit 0
Read:	AUTO	LOCK	$\overline{\text{ACQ}}$	XLD	0	0	0	0
Write:								
Reset:	0	0	0	0	0	0	0	0

 = Unimplemented

**Figure 8-4. PLL Bandwidth Control Register (PBWC)**



### AUTO — Automatic Bandwidth Control Bit

This read/write bit selects automatic or manual bandwidth control. When initializing the PLL for manual operation (AUTO = 0), clear the  $\overline{\text{ACQ}}$  bit before turning on the PLL. Reset clears the AUTO bit.

- 1 = Automatic bandwidth control
- 0 = Manual bandwidth control

### LOCK — Lock Indicator Bit

When the AUTO bit is set, LOCK is a read-only bit that becomes set when the VCO clock, CGMVCLK, is locked (running at the programmed frequency). When the AUTO bit is clear, LOCK reads as logic 0 and has no meaning. Reset clears the LOCK bit.

- 1 = VCO frequency correct or locked
- 0 = VCO frequency incorrect or unlocked

### $\overline{\text{ACQ}}$ — Acquisition Mode Bit

When the AUTO bit is set,  $\overline{\text{ACQ}}$  is a read-only bit that indicates whether the PLL is in acquisition mode or tracking mode. When the AUTO bit is clear,  $\overline{\text{ACQ}}$  is a read/write bit that controls whether the PLL is in acquisition or tracking mode.

In automatic bandwidth control mode (AUTO = 1), the last-written value from manual operation is stored in a temporary location and is recovered when manual operation resumes. Reset clears this bit, enabling acquisition mode.

- 1 = Tracking mode
- 0 = Acquisition mode

### XLD — Crystal Loss Detect Bit

When the VCO output, CGMVCLK, is driving CGMOUT, this read/write bit can indicate whether the crystal reference frequency is active or not.

- 1 = Crystal reference not active
- 0 = Crystal reference active

To check the status of the crystal reference, do the following:

1. Write a logic 1 to XLD.
2. Wait  $N \times 4$  cycles. N is the VCO frequency multiplier.
3. Read XLD.

The crystal loss detect function works only when the BCS bit is set, selecting CGMVCLK to drive CGMOUT. When BCS is clear, XLD always reads as logic 0.

### Bits 3–0 — Reserved for Test

These bits enable test functions not available in user mode. To ensure software portability from development systems to user applications, software should write 0s to bits 3–0 when writing to PBWC.

## 8.6.3 PLL Programming Register

The PLL programming register contains the programming information for the modulo feedback divider and the programming information for the hardware configuration of the VCO.

Address: \$001E

	Bit 7	6	5	4	3	2	1	Bit 0
Read:	MUL7	MUL6	MUL5	MUL4	VRS7	VRS6	VRS5	VRS4
Write:								
Reset:	0	1	1	0	0	1	1	0

**Figure 8-5. PLL Programming Register (PPG)**

### MUL7–MUL4 — Multiplier Select Bits

These read/write bits control the modulo feedback divider that selects the VCO frequency multiplier, N. (See [8.4.2.1 Circuits](#) and [8.4.2.4 Programming the PLL](#).) A value of \$0 in the multiplier select bits configures the modulo feedback divider the same as a value of \$1. Reset initializes these bits to \$6 to give a default multiply value of 6.

**Table 8-3. VCO Frequency Multiplier (N) Selection**

MUL7:MUL6:MUL5:MUL4	VCO Frequency Multiplier (N)
0000	1
0001	1
0010	2
0011	3
↓	↓
1101	13
1110	14
1111	15

**NOTE:** *The multiplier select bits have built-in protection that prevents them from being written when the PLL is on (PLLON = 1).*

#### VRS7–VRS4 — VCO Range Select Bits

These read/write bits control the hardware center-of-range linear multiplier L, which controls the hardware center-of-range frequency,  $f_{VRS}$ . (See [8.4.2.1 Circuits](#), [8.4.2.4 Programming the PLL](#), and [8.6.1 PLL Control Register](#).) VRS7–VRS4 cannot be written when the PLLON bit in the PLL control register (PCTL) is set. [8.4.2.5 Special Programming Exceptions](#) A value of \$0 in the VCO range select bits disables the PLL and clears the BCS bit in the PCTL. (See [8.4.3 Base Clock Selector Circuit](#) and [8.4.2.5 Special Programming Exceptions](#) for more information.) Reset initializes the bits to \$6 to give a default range multiply value of 6.

**NOTE:** *The VCO range select bits have built-in protection that prevents them from being written when the PLL is on (PLLON = 1) and prevents selection of the VCO clock as the source of the base clock (BCS = 1) if the VCO range select bits are all clear.*

*The VCO range select bits must be programmed correctly. Incorrect programming can result in failure of the PLL to achieve lock.*

## 8.7 Interrupts

When the AUTO bit is set in the PLL bandwidth control register (PBWC), the PLL can generate a CPU interrupt request every time the LOCK bit changes state. The PLLIE bit in the PLL control register (PCTL) enables CPU interrupt requests from the PLL. PLLF, the interrupt flag in the PCTL, becomes set whether CPU interrupt requests are enabled or not. When the AUTO bit is clear, CPU interrupt requests from the PLL are disabled and PLLF reads as logic 0.

Software should read the LOCK bit after a PLL CPU interrupt request to see if the request was due to an entry into lock or an exit from lock. When the PLL enters lock, the VCO clock, CGMVCLK, divided by two can be selected as the CGMOUT source by setting BCS in the PCTL. When the PLL exits lock, the VCO clock frequency is corrupt, and appropriate precautions should be taken. If the application is not frequency sensitive, CPU interrupt requests should be disabled to prevent PLL interrupt service routines from impeding software performance or from exceeding stack limitations.

**NOTE:** *Software can select the CGMVCLK divided by two as the CGMOUT source even if the PLL is not locked (LOCK = 0). Therefore, software should make sure the PLL is locked before setting the BCS bit.*

## 8.8 Low-Power Modes

The WAIT and STOP instructions put the MCU in low-power standby modes.

### 8.8.1 Wait Mode

The CGM remains active in wait mode. Before entering wait mode, software can disengage and turn off the PLL by clearing the BCS and PLLON bits in the PLL control register (PCTL). Less power-sensitive applications can disengage the PLL without turning it off. Applications that require the PLL to wake the MCU from wait mode also can deselect the PLL output without turning off the PLL.

## 8.8.2 Stop Mode

The STOP instruction disables the CGM and holds low all CGM outputs (CGMXCLK, CGMOUT, and CGMINT).

If CGMOUT is being driven by CGMVCLK and a STOP instruction is executed; the PLL will clear the BCS bit in the PLL control register, causing CGMOUT to be driven by CGMXCLK. When the MCU recovers from STOP, the crystal clock divided by two drives CGMOUT and BCS remains clear.

## 8.9 CGM During Break Interrupts

The BCFE bit in the break flag control register (BFCR) enables software to clear status bits during the break state. (See [Section 11. Break Module \(BRK\)](#).)

To allow software to clear status bits during a break interrupt, write a logic 1 to the BCFE bit. If a status bit is cleared during the break state, it remains cleared when the MCU exits the break state.

To protect the PLLF bit during the break state, write a logic 0 to the BCFE bit. With BCFE at logic 0 (its default state), software can read and write the PLL control register during the break state without affecting the PLLF bit.

## 8.10 Acquisition/Lock Time Specifications

The acquisition and lock times of the PLL are, in many applications, the most critical PLL design parameters. Proper design and use of the PLL ensures the highest stability and lowest acquisition/lock times.

### 8.10.1 Acquisition/Lock Time Definitions

Typical control systems refer to the acquisition time or lock time as the reaction time, within specified tolerances, of the system to a step input. In a PLL, the step input occurs when the PLL is turned on or when it suffers a noise hit. The tolerance is usually specified as a percent of the step input or when the output settles to the desired value plus or minus a percent of the frequency change. Therefore, the reaction time is constant in this definition, regardless of the size of the step input. For example, consider a system with a 5% acquisition time tolerance. If a command instructs the system to change from 0 Hz to 1 MHz, the acquisition time is the time taken for the frequency to reach  $1\text{ MHz} \pm 50\text{ kHz}$ . Fifty kHz = 5% of the 1-MHz step input. If the system is operating at 1 MHz and suffers a  $-100\text{ kHz}$  noise hit, the acquisition time is the time taken to return from 900 kHz to  $1\text{ MHz} \pm 5\text{ kHz}$ . Five kHz = 5% of the 100-kHz step input.

Other systems refer to acquisition and lock times as the time the system takes to reduce the error between the actual output and the desired output to within specified tolerances. Therefore, the acquisition or lock time varies according to the original error in the output. Minor errors may not even be registered. Typical PLL applications prefer to use this definition because the system requires the output frequency to be within a certain tolerance of the desired frequency regardless of the size of the initial error.

The discrepancy in these definitions makes it difficult to specify an acquisition or lock time for a typical PLL. Therefore, the definitions for acquisition and lock times for this module are:

- Acquisition time,  $t_{acq}$ , is the time the PLL takes to reduce the error between the actual output frequency and the desired output frequency to less than the tracking mode entry tolerance,  $\Delta_{trk}$ . Acquisition time is based on an initial frequency error,  $(f_{des} - f_{orig})/f_{des}$ , of not more than  $\pm 100\%$ . In automatic bandwidth control mode (see [8.4.2.3 Manual and Automatic PLL Bandwidth Modes](#)), acquisition time expires when the  $\overline{ACQ}$  bit becomes set in the PLL bandwidth control register (PBWC).

- Lock time,  $t_{\text{Lock}}$ , is the time the PLL takes to reduce the error between the actual output frequency and the desired output frequency to less than the lock mode entry tolerance,  $\Delta_{\text{Lock}}$ . Lock time is based on an initial frequency error,  $(f_{\text{des}} - f_{\text{orig}})/f_{\text{des}}$ , of not more than  $\pm 100\%$ . In automatic bandwidth control mode, lock time expires when the LOCK bit becomes set in the PLL bandwidth control register (PBWC). (See [8.4.2.3 Manual and Automatic PLL Bandwidth Modes](#).)

Obviously, the acquisition and lock times can vary according to how large the frequency error is and may be shorter or longer in many cases.

### 8.10.2 Parametric Influences on Reaction Time

Acquisition and lock times are designed to be as short as possible while still providing the highest possible stability. These reaction times are not constant, however. Many factors directly and indirectly affect the acquisition time.

The most critical parameter which affects the reaction times of the PLL is the reference frequency,  $f_{\text{RDV}}$ . This frequency is the input to the phase detector and controls how often the PLL makes corrections. For stability, the corrections must be small compared to the desired frequency, so several corrections are required to reduce the frequency error. Therefore, the slower the reference the longer it takes to make these corrections. This parameter is also under user control via the choice of crystal frequency  $f_{\text{XCLK}}$ .

Another critical parameter is the external filter capacitor. The PLL modifies the voltage on the VCO by adding or subtracting charge from this capacitor. Therefore, the rate at which the voltage changes for a given frequency error (thus a change in charge) is proportional to the capacitor size. The size of the capacitor also is related to the stability of the PLL. If the capacitor is too small, the PLL cannot make small enough adjustments to the voltage and the system cannot lock. If the capacitor is too large, the PLL may not be able to adjust the voltage in a reasonable time. (See [8.10.3 Choosing a Filter Capacitor](#).)

Also important is the operating voltage potential applied to  $V_{DDA}$ . The power supply potential alters the characteristics of the PLL. A fixed value is best. Variable supplies, such as batteries, are acceptable if they vary within a known range at very slow speeds. Noise on the power supply is not acceptable, because it causes small frequency errors which continually change the acquisition time of the PLL.

Temperature and processing also can affect acquisition time because the electrical characteristics of the PLL change. The part operates as specified as long as these influences stay within the specified limits. External factors, however, can cause drastic changes in the operation of the PLL. These factors include noise injected into the PLL through the filter capacitor, filter capacitor leakage, stray impedances on the circuit board, and even humidity or circuit board contamination.

### 8.10.3 Choosing a Filter Capacitor

As described in [8.10.2 Parametric Influences on Reaction Time](#), the external filter capacitor,  $C_F$ , is critical to the stability and reaction time of the PLL. The PLL is also dependent on reference frequency and supply voltage. The value of the capacitor must, therefore, be chosen with supply potential and reference frequency in mind. For proper operation, the external filter capacitor must be chosen according to this equation:

$$C_F = C_{\text{fact}} \left( \frac{V_{DDA}}{f_{rdv}} \right)$$

For acceptable values of  $C_{\text{fact}}$ , see [Section 29. Electrical Specifications](#). For the value of  $V_{DDA}$ , choose the voltage potential at which the MCU is operating. If the power supply is variable, choose a value near the middle of the range of possible supply values.

This equation does not always yield a commonly available capacitor size, so round to the nearest available size. If the value is between two different sizes, choose the higher value for better stability. Choosing the lower size may seem attractive for acquisition time improvement, but the PLL may become unstable. Also, always choose a capacitor with a tight tolerance ( $\pm 20\%$  or better) and low dissipation.



## 8.10.4 Reaction Time Calculation

The actual acquisition and lock times can be calculated using the equations below. These equations yield nominal values under the following conditions:

- Correct selection of filter capacitor,  $C_F$  (See [8.10.3 Choosing a Filter Capacitor.](#))
- Room temperature operation
- Negligible external leakage on CGMXFC
- Negligible noise

The K factor in the equations is derived from internal PLL parameters.  $K_{acq}$  is the K factor when the PLL is configured in acquisition mode, and  $K_{trk}$  is the K factor when the PLL is configured in tracking mode. (See [8.4.2.2 Acquisition and Tracking Modes.](#))

$$t_{acq} = \left( \frac{V_{DDA}}{f_{RDV}} \right) \left( \frac{8}{K_{ACQ}} \right)$$

$$t_{al} = \left( \frac{V_{DDA}}{f_{RDV}} \right) \left( \frac{4}{K_{TRK}} \right)$$

$$t_{Lock} = t_{ACQ} + t_{AL}$$

Note the inverse proportionality between the lock time and the reference frequency.

In automatic bandwidth control mode, the acquisition and lock times are quantized into units based on the reference frequency. (See [8.4.2.3 Manual and Automatic PLL Bandwidth Modes](#).) A certain number of clock cycles,  $n_{ACQ}$ , is required to ascertain that the PLL is within the tracking mode entry tolerance,  $\Delta_{TRK}$ , before exiting acquisition mode. A certain number of clock cycles,  $n_{TRK}$ , is required to ascertain that the PLL is within the lock mode entry tolerance,  $\Delta_{Lock}$ . Therefore, the acquisition time,  $t_{ACQ}$ , is an integer multiple of  $n_{ACQ}/f_{RDV}$ , and the acquisition to lock time,  $t_{AL}$ , is an integer multiple of  $n_{TRK}/f_{RDV}$ . Also, since the average frequency over the entire measurement period must be within the specified tolerance, the total time usually is longer than  $t_{Lock}$  as calculated above.

In manual mode, it is usually necessary to wait considerably longer than  $t_{Lock}$  before selecting the PLL clock (see [8.4.3 Base Clock Selector Circuit](#)) because the factors described in [8.10.2 Parametric Influences on Reaction Time](#) may slow the lock time considerably.

## Section 9. Configuration Register (CONFIG-1)

### 9.1 Contents

9.2	Introduction .....	167
9.3	Functional Description .....	168

### 9.2 Introduction

This section describes the configuration register (CONFIG-1), which contains bits that configure these options:

- Resets caused by the LVI module
- Power to the LVI module
- LVI enabled during stop mode
- Stop mode recovery time (32 CGMXCLK cycles or 4096 CGMXCLK cycles)
- Computer operating properly module (COP)
- FLASH Security Feature<sup>1</sup>

---

1. No security feature is absolutely secure. However, Freescale's strategy is to make reading or copying the FLASH difficult for unauthorized users.

## Configuration Register (CONFIG-1)

### 9.3 Functional Description

The configuration register is a write-once register. Out of reset, the configuration register will read the default value. Once the register is written, further writes will have no effect until a reset occurs.

**NOTE:** *If the LVI module and the LVI reset signal are enabled, a reset occurs when  $V_{DD}$  falls to a voltage,  $LVI_{TRIPF}$ , and remains at or below that level for at least nine consecutive CPU cycles. Once an LVI reset occurs, the MCU remains in reset until  $V_{DD}$  rises to a voltage,  $LVI_{TRIPR}$ .*

Address: \$001F

	Bit 7	6	5	4	3	2	1	Bit 0
Read:	LVISTOP	R	LVIRST	LVIPWR	SSREC	COPRS	STOP	COPD
Write:								
Reset:	0	1	1	1	0	0	0	0

R = Reserved

**Figure 9-1. Configuration Register (CONFIG-1)**

#### LVISTOP — LVI Stop Mode Enable Bit

LVISTOP enables the LVI module in stop mode. (See [Section 14. Low-Voltage Inhibit \(LVI\)](#).)

1 = LVI enabled during stop mode

0 = LVI disabled during stop mode

**NOTE:** *To have the LVI enabled in stop mode, the LVIPWR must be at a logic 0 and the LVISTOP bit must be at a logic 1. Take note that by enabling the LVI in stop mode, the stop  $I_{DD}$  current will be higher and for compatibility when using a MC68HC08AS20 a register bit will have to be written. See the LVI section of the MC68HC08AS20 General Release Specification.*

#### LVIRST — LVI Reset Enable Bit

LVIRST enables the reset signal from the LVI module. (See [Section 14. Low-Voltage Inhibit \(LVI\)](#).)

1 = LVI module resets enabled

0 = LVI module resets disabled

**LVIPWR — LVI Power Enable Bit**

LVIPWR enables the LVI module. (See [Section 14. Low-Voltage Inhibit \(LVI\)](#).)

- 1 = LVI module power enabled
- 0 = LVI module power disabled

**SSREC — Short Stop Recovery Bit**

SSREC enables the CPU to exit stop mode with a delay of 32 CGMXCLK cycles instead of a 4096-CGMXCLK cycle delay. (See [7.7.2 Stop Mode](#).)

- 1 = Stop mode recovery after 32 CGMXCLK cycles
- 0 = Stop mode recovery after 4096 CGMXCLK cycles

**NOTE:** *If using an external crystal oscillator, do not set the SSREC bit.*

**COPRS — COP Rate Select Bit**

COPRS selects either the short COP timeout period or the long COP timeout period. (See [Section 13. Computer Operating Properly Module \(COP\)](#).)

- 1 = COP timeout period is 8,176 CGMXCLK cycles
- 0 = COP timeout period is 262,128 CGMXCLK cycles

**STOP — STOP Instruction Enable Bit**

STOP enables the STOP instruction.

- 1 = STOP instruction enabled
- 0 = STOP instruction treated as illegal opcode

**COPD — COP Disable Bit**

COPD disables the COP module. (See [Section 13. Computer Operating Properly Module \(COP\)](#).)

- 1 = COP module disabled
- 0 = COP module enabled



## Configuration Register (CONFIG-1)

## Section 10. Configuration Register (CONFIG-2)

### 10.1 Contents

10.2	Introduction .....	171
10.3	Functional Description .....	172

### 10.2 Introduction

This section describes the configuration register (CONFIG-2). This register contains bits that configure these options:

- Configures the MC68HC908AT32 to either the MC68HC08AZ32 emulator or the MC68HC08AS20 emulator
- Enables the memory extension for the MC68HC08AS20 emulator
- Disables the CAN module

**NOTE:** *The MEMEXT bit comes up enabled. If you are planning or emulating an MC68HC08AS20 be aware this extra memory is not available.*

## 10.3 Functional Description

The configuration register is a write-once register. Out of reset, the configuration register will read the default. Once the register is written, further writes will have no effect until a reset occurs.

Address: \$FE09

	Bit 7	6	5	4	3	2	1	Bit 0
Read:	0	0	0	MSCAND	0	0	MEMEXT	AZ32
Write:	0	0	0	MSCAND	0	0	MEMEXT	AZ32
Reset:	0	0	0	1	0	0	1	0

**Figure 10-1. Configuration Register (CONFIG-2)**

### MSCAND — MSCAN Disable Bit

MSCAND disables the MSCAN module. (See [Section 23. MSCAN Controller.](#))

- 1 = MSCAN module disabled
- 0 = MSCAN Module enabled

### MEMEXT — Memory Extention Enable Bit

MEMEXT enables the extra memory locations in the RAM and the FLASH modules.(See [Section 2. Memory Map.](#))

- 1 = Extra RAM and FLASH enabled
- 0 = Extra RAM and FLASH disabled

**NOTE:** *This function comes up enabled, be careful when emulating the MC68HC08AS20 since this is not an option on the MC68HC08AS20.*

*This function is primarily for the MC68HC08AS20 emulator. If this bit is enabled in the MC68HC08AZ32 emulator configuration, there will be no effect on the memory map, considering these memory sections already exist.*

### AZ32 — AZ32 Emulator Enable Bit

AZ32 enables the MC68HC08AZ32 emulator configuration. This bit will be 0 out of reset.

- 1 = MC68HC08AZ32 emulator protocol enabled
- 0 = MC68HC08AS20 emulator protocol enabled



## Section 11. Break Module (BRK)

### 11.1 Contents

11.2	Introduction .....	173
11.3	Features .....	174
11.4	Functional Description .....	174
11.4.1	Flag Protection During Break Interrupts .....	176
11.4.2	CPU During Break Interrupts .....	176
11.4.3	TIM During Break Interrupts .....	176
11.4.4	COP During Break Interrupts .....	176
11.5	Low-Power Modes .....	177
11.5.1	Wait Mode .....	177
11.5.2	Stop Mode .....	177
11.6	Break Module Registers .....	178
11.6.1	Break Status and Control Register .....	178
11.6.2	Break Address Registers .....	179

### 11.2 Introduction

The break module can generate a break interrupt that stops normal program flow at a defined address to enter a background program.

## 11.3 Features

- Accessible I/O Registers during Break Interrupts
- CPU-Generated Break Interrupts
- Software-Generated Break Interrupts
- COP Disabling during Break Interrupts

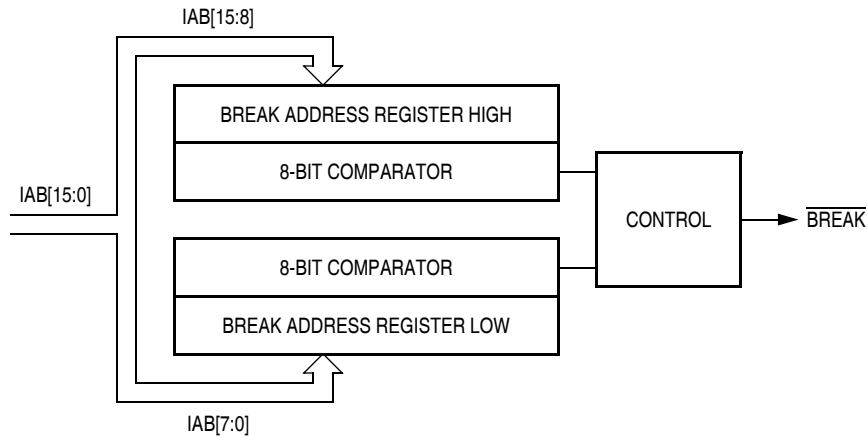
## 11.4 Functional Description

When the internal address bus matches the value written in the break address registers, the break module issues a breakpoint signal to the CPU. The CPU then loads the instruction register with a software interrupt instruction (SWI) after completion of the current CPU instruction. The program counter vectors to \$FFFC and \$FFFD (\$FEFC and \$FEFD in monitor mode).

The following events can cause a break interrupt to occur:

- A CPU-generated address (the address in the program counter) matches the contents of the break address registers.
- Software writes a logic 1 to the BRKA bit in the break status and control register.

When a CPU-generated address matches the contents of the break address registers, the break interrupt begins after the CPU completes its current instruction. A return-from-interrupt instruction (RTI) in the break routine ends the break interrupt and returns the MCU to normal operation. [Figure 11-1](#) shows the structure of the break module.


**Figure 11-1. Break Module Block Diagram**
**Table 11-1. I/O Register Summary**

Addr.	Register Name		Bit 7	6	5	4	3	2	1	Bit 0
\$FE0C	Break Address Register High (BRKH)	Read:	Bit 15	14	13	12	11	10	9	Bit 8
		Write:								
		Reset:	0	0	0	0	0	0	0	0
\$FE0D	Break Address Register Low (BRKL)	Read:	Bit 7	6	5	4	3	2	1	Bit 0
		Write:								
		Reset:	0	0	0	0	0	0	0	0
\$FE0E	Break Status and Control Register (BRKSCR)	Read:	BRKE	BRKA	0	0	0	0	0	0
		Write:								
		Reset:	0	0	0	0	0	0	0	0

= Unimplemented

**Table 11-2. I/O Register Address Summary**

<b>Register</b>	BRKH	BRKL	BSCR
<b>Address</b>	\$FE0C	\$FE0D	\$FE0E

### 11.4.1 Flag Protection During Break Interrupts

The BCFE bit in the break flag control register (BFCR) enables software to clear status bits during the break state.

### 11.4.2 CPU During Break Interrupts

The CPU starts a break interrupt by:

- Loading the instruction register with the SWI instruction
- Loading the program counter with \$FFFC:\$FFFD (\$FEFC:\$FEFD in monitor mode)

The break interrupt begins after completion of the CPU instruction in progress. If the break address register match occurs on the last cycle of a CPU instruction, the break interrupt begins immediately.

### 11.4.3 TIM During Break Interrupts

A break interrupt stops the timer counter.

### 11.4.4 COP During Break Interrupts

The COP is disabled during a break interrupt when  $V_{DD} + V_{Hi}$  is present on the  $\overline{RST}$  pin.

## 11.5 Low-Power Modes

The WAIT and STOP instructions put the MCU in low-power standby modes.

### 11.5.1 Wait Mode

If enabled, the break module is active in wait mode. The SIM break stop/wait bit (SBSW) in the SIM break status register indicates whether wait was exited by a break interrupt. If so, the user can modify the return address on the stack by subtracting one from it. (See [7.8.1 SIM Break Status Register](#).)

### 11.5.2 Stop Mode

The break module is inactive in stop mode. The STOP instruction does not affect break module register states. A break interrupt will cause an exit from stop mode and sets the SBSW bit in the SIM break status register.

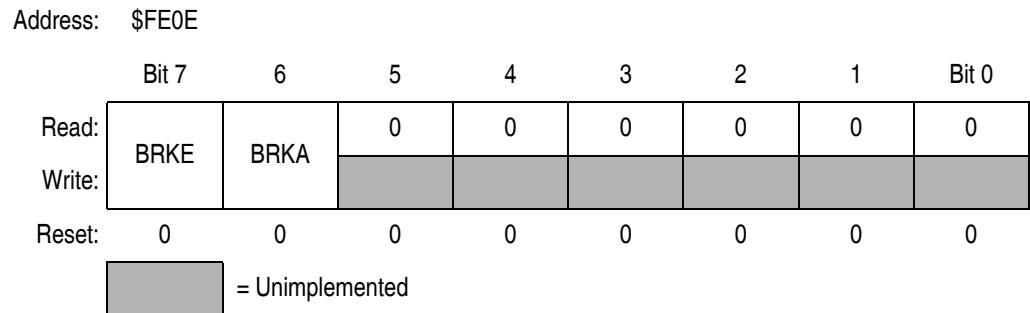
## 11.6 Break Module Registers

These registers control and monitor operation of the break module:

- Break address register high (BRKH)
- Break address register low (BRKL)
- Break status register (BSR)

### 11.6.1 Break Status and Control Register

The break status and control register contains break module enable and status bits.



**Figure 11-2. Break Status and Control Register (BSCR)**

#### BRKE — Break Enable Bit

This read/write bit enables breaks on break address register matches. Clear BRKE by writing a logic 0 to bit 7. Reset clears the BRKE bit.

- 1 = Breaks enabled on 16-bit address match
- 0 = Breaks disabled on 16-bit address match

### BRKA — Break Active Bit

This read/write status and control bit is set when a break address match occurs. Writing a logic 1 to BRKA generates a break interrupt. Clear BRKA by writing a logic 0 to it before exiting the break routine. Reset clears the BRKA bit.

1 = (When read) Break address match

0 = (When read) No break address match

## 11.6.2 Break Address Registers

The break address registers contain the high and low bytes of the desired breakpoint address. Reset clears the break address registers.

Register Name and Address: BRKH — \$FE0C

	Bit 7	6	5	4	3	2	1	Bit 0
Read:	Bit 15	14	13	12	11	10	9	Bit 8
Write:								
Reset:	0	0	0	0	0	0	0	0

Register Name and Address: BRKHL — \$FE0D

	Bit 7	6	5	4	3	2	1	Bit 0
Read:	Bit 7	6	5	4	3	2	1	Bit 0
Write:								
Reset:	0	0	0	0	0	0	0	0

**Figure 11-3. Break Address Registers (BRKH and BRKL)**





## Section 12. Monitor ROM (MON)

### 12.1 Contents

12.2	Introduction	181
12.3	Features	182
12.4	Functional Description	182
12.4.1	Entering Monitor Mode	184
12.4.2	Data Format	185
12.4.3	Echoing	186
12.4.4	Break Signal	186
12.4.5	Commands	187
12.4.6	Baud Rate	190

### 12.2 Introduction

This section describes the monitor ROM (MON). The monitor ROM allows complete testing of the MCU through a single-wire interface with a host computer.

## 12.3 Features

Features of the monitor ROM include:

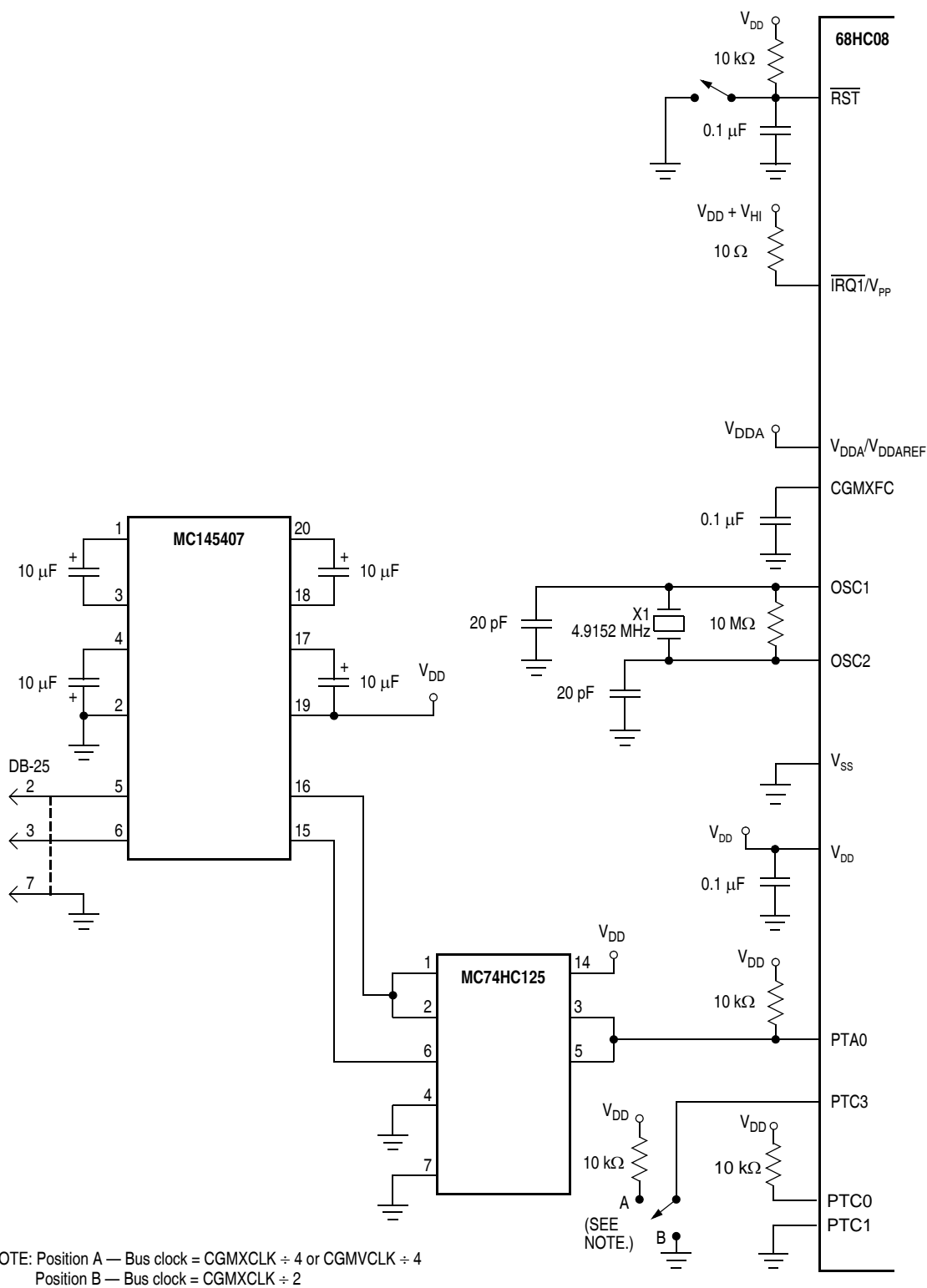
- Normal User-Mode Pin Functionality
- One Pin Dedicated to Serial Communication between Monitor ROM and Host Computer
- Standard Mark/Space Non-Return-to-Zero (NRZ) Communication with Host Computer
- 4800 Baud–28.8 kBaud Communication with Host Computer
- Execution of Code in RAM or ROM

## 12.4 Functional Description

Monitor ROM receives and executes commands from a host computer. [Figure 12-1](#) shows a sample circuit used to enter monitor mode and communicate with a host computer via a standard RS-232 interface.

While simple monitor commands can access any memory address, the MC68HC908AT32 has a FLASH security feature to prevent external viewing of the contents of FLASH. Proper procedures must be followed to verify FLASH content. Access to the FLASH is denied to unauthorized users of customer specified software.

In monitor mode, the MCU can execute host-computer code in RAM while all MCU pins except PTA0 retain normal operating mode functions. All communication between the host computer and the MCU is through the PTA0 pin. A level-shifting and multiplexing interface is required between PTA0 and the host computer. PTA0 is used in a wired-OR configuration and requires a pullup resistor.


**Figure 12-1. Monitor Mode Circuit**

## 12.4.1 Entering Monitor Mode

**Table 12-1** shows the pin conditions for entering monitor mode.

**Table 12-1. Mode Selection**

IRQ Pin	PTC0 Pin	PTC1 Pin	PTA0 Pin	PTC3 Pin	Mode	CGMOUT	Bus Frequency
$V_{DD} + V_{HI}^1$	1	0	1	1	Monitor	$\frac{CGMXCLK}{2}$ or $\frac{CGMVCLK}{2}$	$\frac{CGMOUT}{2}$
$V_{DD} + V_{HI}^{(1)}$	1	0	1	0	Monitor	CGMXCLK	$\frac{CGMOUT}{2}$

1. For  $V_{HI}$ , see [29.5 5.0 Volt DC Electrical Characteristics](#) and [29.2 Maximum Ratings](#).

Enter monitor mode by either

- Executing a software interrupt instruction (SWI) or
- Applying a logic 0 and then a logic 1 to the  $\overline{RST}$  pin.

The MCU sends a break signal (10 consecutive logic 0s) to the host computer, indicating that it is ready to receive a command. The break signal also provides a timing reference to allow the host to determine the necessary baud rate.

Monitor mode uses alternate vectors for reset, SWI, and break interrupt. The alternate vectors are in the \$FE page instead of the \$FF page and allow code execution from the internal monitor firmware instead of user code. The COP module is disabled in monitor mode as long as  $V_{DD} + V_{HI}$  (see [29.5 5.0 Volt DC Electrical Characteristics](#)) is applied to either the  $\overline{IRQ}$  pin or the  $V_{DD}$  pin. (See [Section 7. System Integration Module \(SIM\)](#) for more information on modes of operation.)

**NOTE:** *Holding the PTC3 pin low when entering monitor mode causes a bypass of a divide-by-two stage at the oscillator. The CGMOUT frequency is equal to the CGMXCLK frequency, and the OSC1 input directly generates internal bus clocks. In this case, the OSC1 signal must have a 50% duty cycle at maximum bus frequency.*

**Table 12-2** is a summary of the differences between user mode and monitor mode.

**Table 12-2. Mode Differences**

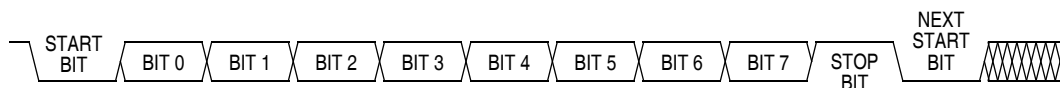
Modes	Functions						
	COP	Reset Vector High	Reset Vector Low	Break Vector High	Break Vector Low	SWI Vector High	SWI Vector Low
User	Enabled	\$FFFE	\$FFFF	\$FFFC	\$FFFD	\$FFFC	\$FFFD
Monitor	Disabled <sup>(1)</sup>	\$FEFE	\$FEFF	\$FEFC	\$FEFD	\$FEFC	\$FEFD

1. If the high voltage ( $V_{DD} + V_{HI}$ ) is removed from the  $\overline{IRQ1}/V_{PP}$  pin while in monitor mode, the SIM asserts its COP enable output. The COP is a mask option enabled or disabled by the COPD bit in the configuration register. (See [29.5 5.0 Volt DC Electrical Characteristics](#).)

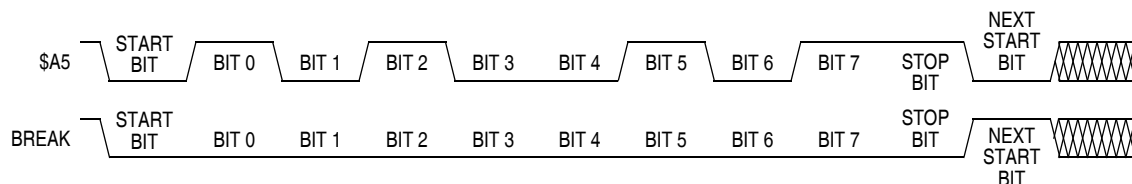
## 12.4.2 Data Format

Communication with the monitor ROM is in standard non-return-to-zero (NRZ) mark/space data format. (See [Figure 12-2](#) and [Figure 12-3](#).)

The data transmit and receive rate can be anywhere from 4800 baud to 28.8 kBaud. Transmit and receive baud rates must be identical.



**Figure 12-2. Monitor Data Format**

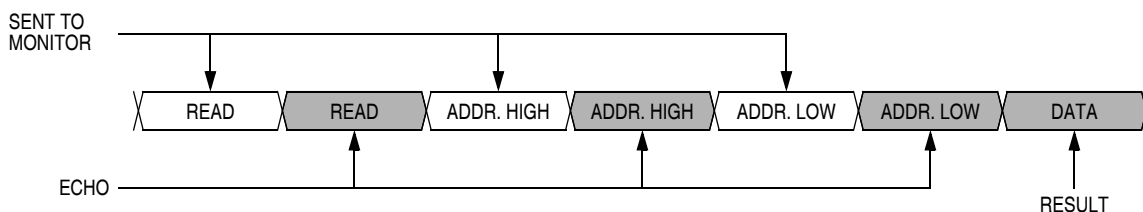


**Figure 12-3. Sample Monitor Waveforms**

## 12.4.3 Echoing

As shown in [Figure 12-4](#), the monitor ROM immediately echoes each received byte back to the PTA0 pin for error checking.

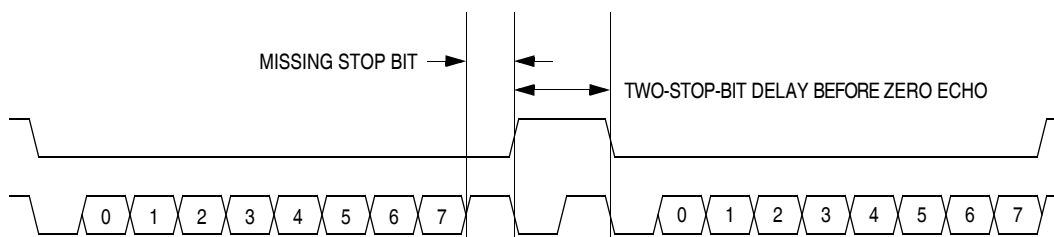
Any result of a command appears after the echo of the last byte of the command.



**Figure 12-4. Read Transaction**

## 12.4.4 Break Signal

A start bit followed by nine low bits is a break signal. (See [Figure 12-5](#).) When the monitor receives a break signal, it drives the PTA0 pin high for the duration of two bits before echoing the break signal.



**Figure 12-5. Break Transaction**

## 12.4.5 Commands

The monitor ROM uses these commands:

- READ, read memory
- WRITE, write memory
- IREAD, indexed read
- IWRITE, indexed write
- READSP, read stack pointer
- RUN, run user program

A sequence of IREAD or IWRITE commands can access a block of memory sequentially over the full 64-Kbyte memory map.

**Table 12-3. READ (Read Memory) Command**

Description	Read byte from memory
Operand	Specifies 2-byte address in high byte:low byte order
Data Returned	Returns contents of specified address
Opcode	\$4A
Command Sequence	
<pre> graph LR     subgraph Sequence [Command Sequence]         direction LR         B1[READ] --- B2[READ] --- B3[ADDR. HIGH] --- B4[ADDR. HIGH] --- B5[ADDR. LOW] --- B6[ADDR. LOW] --- B7[DATA]     end     SM[SENT TO MONITOR] --&gt; B1     SM --&gt; B2     SM --&gt; B3     E[ECHO] --&gt; B2     E --&gt; B3     E --&gt; B4     E --&gt; B5     R[RESULT] --&gt; B7                 </pre>	





**Table 12-4. WRITE (Write Memory) Command**

Description	Write byte to memory
Operand	Specifies 2-byte address in high byte:low byte order; low byte followed by data byte
Data Returned	None
Opcode	\$49
Command Sequence	

**Table 12-5. IREAD (Indexed Read) Command**

Description	Read next 2 bytes in memory from last address accessed
Operand	Specifies 2-byte address in high byte:low byte order
Data Returned	Returns contents of next two addresses
Opcode	\$1A
Command Sequence	

**Table 12-6. IWRITE (Indexed Write) Command**

Description	Write to last address accessed + 1
Operand	Specifies single data byte
Data Returned	None
Opcode	\$19
<p>Command Sequence</p> <p>The diagram shows a sequence of four data bytes: IWRITE, IWRITE, DATA, and DATA. The first IWRITE and the first DATA are labeled 'SENT TO MONITOR' with arrows pointing to them from above. The second IWRITE and the second DATA are labeled 'ECHO' with arrows pointing to them from below.</p>	

**Table 12-7. READSP (Read Stack Pointer) Command**

Description	Reads stack pointer
Operand	None
Data Returned	Returns stack pointer in high byte:low byte order
Opcode	\$0C
<p>Command Sequence</p> <p>The diagram shows a sequence of four data bytes: READSP, READSP, SP HIGH, and SP LOW. The first READSP is labeled 'SENT TO MONITOR' with an arrow pointing to it from above. The second READSP is labeled 'ECHO' with an arrow pointing to it from below. The SP HIGH and SP LOW bytes are labeled 'RESULT' with arrows pointing to them from below.</p>	



**Table 12-8. RUN (Run User Program) Command**

Description	Executes RTI instruction
Operand	None
Data Returned	None
Opcode	\$28
Command Sequence	

## 12.4.6 Baud Rate

With a 4.9152-MHz crystal and the PTC3 pin at logic 1 during reset, data is transferred between the monitor and host at 4800 baud. If the PTC3 pin is at logic 0 during reset, the monitor baud rate is 9600. When the CGM output, CGMOUT, is driven by the PLL, the baud rate is determined by the MUL[7:4] bits in the PLL programming register (PPG). (See [Section 8. Clock Generator Module \(CGM\)](#).)

**Table 12-9. Monitor Baud Rate Selection**

Monitor Baud Rate	VCO Frequency Multiplier (N)					
	1	2	3	4	5	6
4.9152 MHz	4800	9600	14,400	19,200	24,000	28,800
4.194 MHz	4096	8192	12,288	16,384	20,480	24,576

## Section 13. Computer Operating Properly Module (COP)

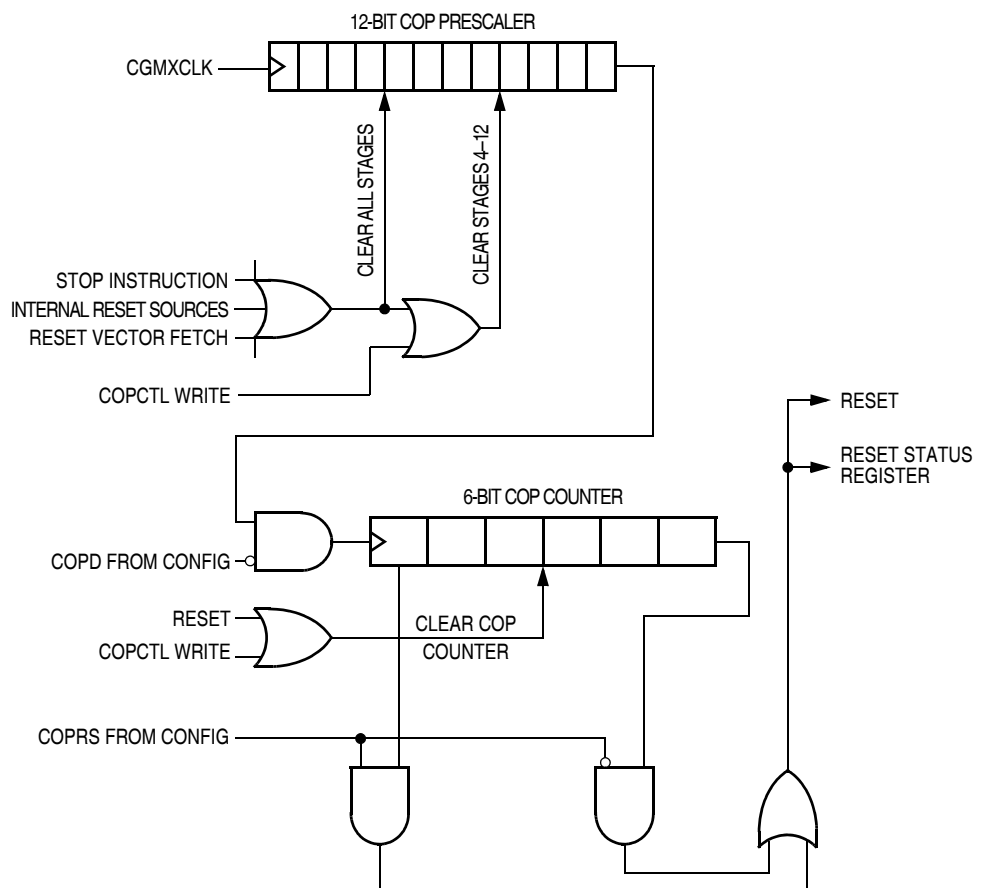
### 13.1 Contents

13.2	Introduction	192
13.3	Functional Description	192
13.4	I/O Signals	194
13.4.1	CGMXCLK	194
13.4.2	STOP Instruction	194
13.4.3	COPCTL Write	194
13.4.4	Power-On Reset	194
13.4.5	Internal Reset	194
13.4.6	Reset Vector Fetch	194
13.4.7	COPD	195
13.4.8	COPRS	195
13.5	COPRS Control Register	195
13.6	Interrupts	195
13.7	Monitor Mode	196
13.8	Low-Power Modes	196
13.8.1	Wait Mode	196
13.8.2	Stop Mode	196
13.9	COP Module During Break Interrupts	196

## 13.2 Introduction

The COP module contains a free-running counter that generates a reset if allowed to overflow. The COP module helps software recover from runaway code. Prevent a COP reset by periodically clearing the COP counter.

## 13.3 Functional Description



**Figure 13-1. COP Block Diagram**

The COP counter is a free-running 6-bit counter preceded by the 12-bit system integration module (SIM) counter. COP timeouts are determined strictly by the CGM crystal oscillator clock signal (CGMXCLK), not the CGMOUT signal (see [Figure 13-1](#)).

If not cleared by software, the COP counter overflows and generates an asynchronous reset after 8,176 or 262,128 CGMXCLK cycles divided by the crystal frequency, depending upon COPRS bit in the configuration register (\$001F). (See [Section 9. Configuration Register \(CONFIG-1\)](#).)

$$\text{COP timeout period} = 8,176 \text{ or } 262,128 / f_{\text{osc}}$$

When COPRS = 0, a 4.9152-MHz crystal gives a COP timeout period of 53.3 ms. Writing any value to location \$FFFF before an overflow occurs prevents a COP reset by clearing the COP counter and stages 4–12 of the SIM counter.

**NOTE:** *Service the COP immediately after reset and before entering or after exiting stop mode to guarantee the maximum time before the first COP counter overflow.*

A COP reset pulls the  $\overline{\text{RST}}$  pin low for 32 CGMXCLK cycles and sets the COP bit in the reset status register (RSR).

In monitor mode, the COP is disabled if the  $\overline{\text{RST}}$  pin or the  $\overline{\text{IRQ}}$  pin is held at  $V_{\text{DD}} + V_{\text{Hi}}$ . During the break state,  $V_{\text{DD}} + V_{\text{Hi}}$  on the  $\overline{\text{RST}}$  pin disables the COP.

**NOTE:** *Place COP clearing instructions in the main program and not in an interrupt subroutine. Such an interrupt subroutine could keep the COP from generating a reset even while the main program is not working properly.*

## 13.4 I/O Signals

The following paragraphs describe the signals shown in [Figure 13-1](#).

### 13.4.1 CGMXCLK

CGMXCLK is the crystal oscillator output signal. CGMXCLK frequency is equal to the crystal frequency.

### 13.4.2 STOP Instruction

The STOP instruction clears the COP prescaler.

### 13.4.3 COPCTL Write

Writing any value to the COP control register (COPCTL) (see [13.5 COP Control Register](#)) clears the COP counter and clears stages 12 through 4 of the COP prescaler. Reading the COP control register returns the reset vector.

### 13.4.4 Power-On Reset

The power-on reset (POR) circuit clears the COP prescaler 4096 CGMXCLK cycles after power-up.

### 13.4.5 Internal Reset

An internal reset clears the COP prescaler and the COP counter.

### 13.4.6 Reset Vector Fetch

A reset vector fetch occurs when the vector address appears on the data bus. A reset vector fetch clears the COP prescaler.



### 13.4.7 COPD

The COPD signal reflects the state of the COP disable bit (COPD) in the configuration register. (See [Section 10. Configuration Register \(CONFIG-2\)](#).)

### 13.4.8 COPRS

The COPRS bit selects the state of the COP rate select timeout bit (COPRS) in the configuration register (\$001F). Timeout periods can be 262,128 or 8,176 CGMXCLK cycles. (See [Section 10. Configuration Register \(CONFIG-2\)](#).)

## 13.5 COP Control Register

The COP control register is located at address \$FFFF and overlaps the reset vector. Writing any value to \$FFFF clears the COP counter and starts a new timeout period. Reading location \$FFFF returns the low byte of the reset vector.

Address:	\$FFFF
	Bit 7      6      5      4      3      2      1      Bit 0
Read:	Low Byte of Reset Vector
Write:	Clear COP Counter
Reset:	Unaffected by Reset

**Figure 13-2. COP Control Register (COPCTL)**

## 13.6 Interrupts

The COP does not generate CPU interrupt requests or DMA service requests.

## 13.7 Monitor Mode

The COP is disabled in monitor mode when  $V_{DD} + V_{Hi}$  is present on the  $\overline{IRQ1/V_{PP}}$  pin or on the  $\overline{RST}$  pin.

## 13.8 Low-Power Modes

The WAIT and STOP instructions put the MCU in low-power standby modes.

### 13.8.1 Wait Mode

The COP remains active in wait mode. To prevent a COP reset during wait mode, periodically clear the COP counter in a CPU interrupt routine or a DMA service routine.

### 13.8.2 Stop Mode

Stop mode turns off the CGMXCLK input to the COP and clears the COP prescaler. Service the COP immediately before entering or after exiting stop mode to ensure a full COP timeout period after entering or exiting stop mode.

The STOP bit in the configuration register (CONFIG) enables the STOP instruction. To prevent inadvertently turning off the COP with a STOP instruction, disable the STOP instruction by clearing the STOP bit.

## 13.9 COP Module During Break Interrupts

The COP is disabled during a break interrupt when  $V_{DD} + V_{Hi}$  is present on the  $\overline{RST}$  pin.

## Section 14. Low-Voltage Inhibit (LVI)

### 14.1 Contents

14.2	Introduction .....	197
14.3	Features .....	198
14.4	Functional Description .....	198
14.4.1	Polled LVI Operation .....	199
14.4.2	Forced Reset Operation .....	199
14.4.3	False Reset Protection .....	200
14.5	LVI Status Register .....	200
14.6	LVI Interrupts .....	201
14.7	Wait Mode .....	201
14.8	Stop Mode .....	201

### 14.2 Introduction

This section describes the low-voltage inhibit module (LVI47, Version A), which monitors the voltage on the  $V_{DD}$  pin and can force a reset when the  $V_{DD}$  voltage falls to the LVI trip voltage.

## 14.3 Features

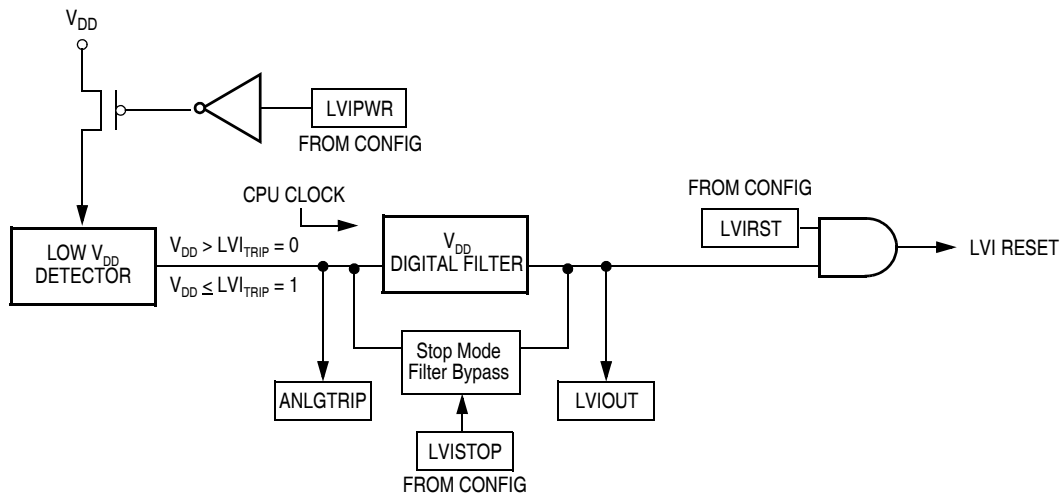
Features of the LVI module include:

- Programmable LVI Reset
- Programmable Power Consumption
- Digital Filtering of  $V_{DD}$  Pin Level

## 14.4 Functional Description

**Figure 14-1** shows the structure of the LVI module. The LVI is enabled out of reset. The LVI module contains a bandgap reference circuit and comparator. The LVI power bit, LVIPWR, enables the LVI to monitor  $V_{DD}$  voltage. The LVI reset bit, LVIRST, enables the LVI module to generate a reset when  $V_{DD}$  falls below a voltage,  $LVI_{TRIPF}$ , and remains at or below that level for nine or more consecutive CPU cycles. LVISTOP, enables the LVI module during stop mode. This will ensure when the STOP instruction is implemented, the LVI will continue to monitor the voltage level on  $V_{DD}$ . LVIPWR, LVISTOP, and LVIRST are in the configuration register (CONFIGA). (See [Section 9. Configuration Register \(CONFIG-1\)](#).) Once an LVI reset occurs, the MCU remains in reset until  $V_{DD}$  rises above a voltage,  $LVI_{TRIPR}$ .  $V_{DD}$  must be above  $LVI_{TRIPR}$  for only one CPU cycle to bring the MCU out of reset. (See [14.4.2 Forced Reset Operation](#).) The output of the comparator controls the state of the LVIOUT flag in the LVI status register (LVISR).

An LVI reset also drives the  $\overline{RST}$  pin low to provide low-voltage protection to external peripheral devices.


**Figure 14-1. LVI Module Block Diagram**
**Table 14-1. LVI I/O Register Summary**

Addr.	Register Name	Bit 7	6	5	4	3	2	1	Bit 0	
\$FE0F	LVI Status Register (LVISR)	Read:	LVIOUT	0	0	0	0	0	0	0
		Write:								
		Reset:	0	0	0	0	0	0	0	0

= Unimplemented

### 14.4.1 Polled LVI Operation

In applications that can operate at  $V_{DD}$  levels below the  $LVI_{TRIPF}$  level, software can monitor  $V_{DD}$  by polling the LVIOUT bit. In the configuration register, the LVIPWR bit must be at logic 0 to enable the LVI module, and the LVIRST bit must be at logic 1 to disable LVI resets.

### 14.4.2 Forced Reset Operation

In applications that require  $V_{DD}$  to remain above the  $LVI_{TRIPF}$  level, enabling LVI resets allows the LVI module to reset the MCU when  $V_{DD}$  falls to the  $LVI_{TRIPF}$  level and remains at or below that level for nine or more consecutive CPU cycles. In the configuration register, the LVIPWR and LVIRST bits must be at logic 0 to enable the LVI module and to enable LVI resets.

## 14.4.3 False Reset Protection

The  $V_{DD}$  pin level is digitally filtered to reduce false resets due to power supply noise. In order for the LVI module to reset the MCU,  $V_{DD}$  must remain at or below the  $LVI_{TRIPF}$  level for nine or more consecutive CPU cycles.  $V_{DD}$  must be above  $LVI_{TRIPR}$  for only one CPU cycle to bring the MCU out of reset.

## 14.5 LVI Status Register

The LVI status register flags  $V_{DD}$  voltages below the  $LVI_{TRIPF}$  level.

Address: \$FE0F

	Bit 7	6	5	4	3	2	1	Bit 0
Read:	LVIOUT	0	0	0	0	0	0	0
Write:								
Reset:	0	0	0	0	0	0	0	0

= Unimplemented

**Figure 14-2. LVI Status Register (LVISR)**

### LVIOUT — LVI Output Bit

This read-only flag becomes set when the  $V_{DD}$  voltage falls below the  $LVI_{TRIPF}$  voltage for 32 to 40 CGMXCLK cycles. (See [Table 14-2.](#)) Reset clears the LVIOUT bit.

**Table 14-2. LVIOUT Bit Indication**

$V_{DD}$		LVIOUT
At Level:	For Number of CGMXCLK Cycles:	
$V_{DD} > LVI_{TRIPR}$	Any	0
$V_{DD} < LVI_{TRIPF}$	< 32 CGMXCLK Cycles	0
$V_{DD} < LVI_{TRIPF}$	Between 32 and 40 CGMXCLK Cycles	0 or 1
$V_{DD} < LVI_{TRIPF}$	> 40 CGMXCLK Cycles	1
$LVI_{TRIPF} < V_{DD} < LVI_{TRIPR}$	Any	Previous Value

## 14.6 LVI Interrupts

The LVI module does not generate interrupt requests.

## 14.7 Wait Mode

The WAIT instruction puts the MCU in low power-consumption standby mode.

With the LVIPWR bit in the configuration register programmed to logic 0, the LVI module is active after a WAIT instruction.

With the LVIRST bit in the configuration register programmed to logic 0, the LVI module can generate a reset and bring the MCU out of wait mode.

## 14.8 Stop Mode

The STOP instruction puts the MCU in low-power mode.

With the LVISTOP and LVIPWR bits in the configuration register programmed to a logic 0, the LVI module will be active after a STOP instruction. Because CPU clocks are disabled during stop mode, the LVI trip must bypass the digital filter to generate a reset and bring the MCU out of stop.

With the LVIPWR bit in the configuration register programmed to logic 0 and the LVISTOP bit at a logic 1, the LVI module will be inactive after a STOP instruction.



## Low-Voltage Inhibit (LVI)



## Section 15. External Interrupt (IRQ)

### 15.1 Contents

15.2	Introduction . . . . .	203
15.3	Features . . . . .	203
15.4	Functional Description . . . . .	204
15.5	IRQ Pin . . . . .	207
15.6	IRQ Module During Break Interrupts . . . . .	208
15.7	IRQ Status and Control Register . . . . .	208

### 15.2 Introduction

This section describes the nonmaskable external interrupt (IRQ) input.

### 15.3 Features

Features include:

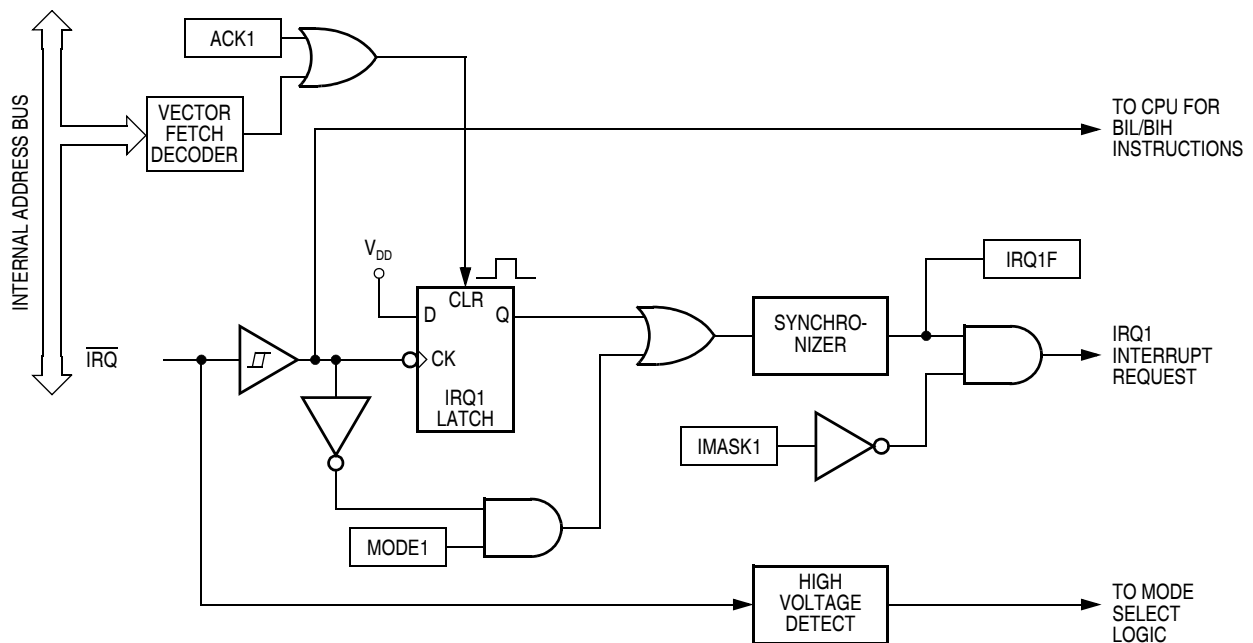
- Dedicated External Interrupt Pin ( $\overline{\text{IRQ}}$ )
- Hysteresis Buffer
- Programmable Edge-Only or Edge- and Level-Interrupt Sensitivity
- Automatic Interrupt Acknowledge

## 15.4 Functional Description

A logic 0 applied to the external interrupt pin can latch a CPU interrupt request. **Figure 15-1** shows the structure of the IRQ module.

Interrupt signals on the  $\overline{\text{IRQ}}$  pin are latched into the IRQ1 latch. An interrupt latch remains set until one of the following actions occurs:

- Vector fetch — A vector fetch automatically generates an interrupt acknowledge signal that clears the latch that caused the vector fetch.
- Software clear — Software can clear an interrupt latch by writing to the appropriate acknowledge bit in the interrupt status and control register (ISCR). Writing a logic 1 to the ACK1 bit clears the IRQ1 latch.
- Reset — A reset automatically clears both interrupt latches.



**Figure 15-1. IRQ Block Diagram**

**Table 15-1. IRQ I/O Register Summary**

Addr.	Register Name	Bit 7	6	5	4	3	2	1	Bit 0	
\$001A	IRQ Status/Control Register (ISCR)	Read:	0	0	0	0	IRQF1	0	IMASK1	MODE1
		Write:	R	R	R	R	R	ACK1		
		Reset:	0	0	0	0	0	0	0	0

R = Reserved

The external interrupt pin is falling-edge triggered and is software-configurable to be both falling-edge and low-level triggered. The MODE1 bit in the ISCR controls the triggering sensitivity of the  $\overline{\text{IRQ}}$  pin.

When an interrupt pin is edge-triggered only, the interrupt latch remains set until a vector fetch, software clear, or reset occurs.

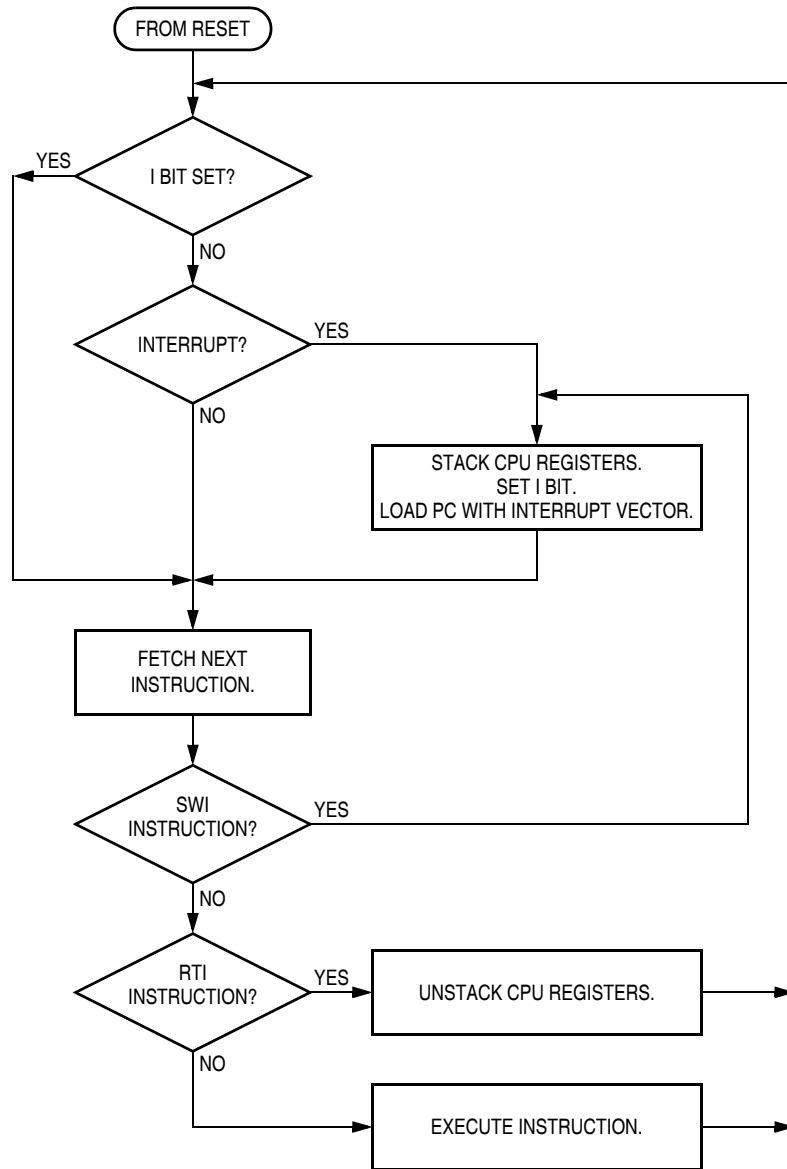
When an interrupt pin is both falling-edge and low-level-triggered, the interrupt latch remains set until both of the following occur:

- Vector fetch or software clear
- Return of the interrupt pin to logic 1

The vector fetch or software clear may occur before or after the interrupt pin returns to logic 1. As long as the pin is low, the interrupt request remains pending. A reset will clear the latch and the MODE1 control bit, thereby clearing the interrupt even if the pin stays low.

When set, the IMASK1 bit in the ISCR masks all external interrupt requests. A latched interrupt request is not presented to the interrupt priority logic unless the corresponding IMASK bit is clear.

**NOTE:** *The interrupt mask (I) in the condition code register (CCR) masks all interrupt requests, including external interrupt requests. (See [Figure 15-2](#).)*



**Figure 15-2. IRQ Interrupt Flowchart**

## 15.5 $\overline{\text{IRQ}}$ Pin

A logic 0 on the  $\overline{\text{IRQ}}$  pin can latch an interrupt request into the IRQ1 latch. A vector fetch, software clear, or reset clears the IRQ1 latch.

If the MODE1 bit is set, the  $\overline{\text{IRQ}}$  pin is both falling-edge sensitive and low-level sensitive. With MODE1 set, both of the following actions must occur to clear the IRQ1 latch:

- Vector fetch or software clear — A vector fetch generates an interrupt acknowledge signal to clear the latch. Software may generate the interrupt acknowledge signal by writing a logic 1 to the ACK1 bit in the interrupt status and control register (ISCR). The ACK1 bit is useful in applications that poll the  $\overline{\text{IRQ}}$  pin and require software to clear the IRQ1 latch. Writing to the ACK1 bit can also prevent spurious interrupts due to noise. Setting ACK1 does not affect subsequent transitions on the  $\overline{\text{IRQ}}$  pin. A falling edge on  $\overline{\text{IRQ}}/V_{PP}$  that occurs after writing to the ACK1 bit latches another interrupt request. If the IRQ1 mask bit, IMASK1, is clear, the CPU loads the program counter with the vector address at locations \$FFFA and \$FFFB.
- Return of the  $\overline{\text{IRQ}}$  pin to logic 1 — As long as the  $\overline{\text{IRQ}}$  pin is at logic 0, the IRQ1 latch remains set.

The vector fetch or software clear and the return of the  $\overline{\text{IRQ}}$  pin to logic 1 can occur in any order. The interrupt request remains pending as long as the  $\overline{\text{IRQ}}$  pin is at logic 0. A reset will clear the latch and the MODE1 control bit, thereby clearing the interrupt even if the pin stays low.

If the MODE1 bit is clear, the  $\overline{\text{IRQ}}$  pin is falling-edge sensitive only. With MODE1 clear, a vector fetch or software clear immediately clears the IRQ1 latch.

The IRQF1 bit in the ISCR register can be used to check for pending interrupts. The IRQF1 bit is not affected by the IMASK1 bit, which makes it useful in applications where polling is preferred.

Use the BIH or BIL instruction to read the logic level on the  $\overline{\text{IRQ}}$  pin.

**NOTE:** *When using the level-sensitive interrupt trigger, avoid false interrupts by masking interrupt requests in the interrupt routine.*

## 15.6 IRQ Module During Break Interrupts

The system integration module (SIM) controls whether the IRQ1 interrupt latch can be cleared during the break state. The BCFE bit in the SIM break flag control register (SBFCR) enables software to clear the latches during the break state. (See [7.8.3 SIM Break Flag Control Register](#).)

To allow software to clear the IRQ1 latch during a break interrupt, write a logic 1 to the BCFE bit. If a latch is cleared during the break state, it remains cleared when the MCU exits the break state.

To protect the latch during the break state, write a logic 0 to the BCFE bit. With BCFE at logic 0 (its default state), writing to the ACK1 bit in the IRQ status and control register during the break state has no effect on the IRQ latch.

## 15.7 IRQ Status and Control Register

The IRQ status and control register (ISCR) controls and monitors operation of the IRQ module. The ISCR has these functions:

- Shows the state of the IRQ1 interrupt flag
- Clears the IRQ1 interrupt latch
- Masks IRQ1 interrupt request
- Controls triggering sensitivity of the  $\overline{\text{IRQ}}$  interrupt pin

Address: \$001A

	Bit 7	6	5	4	3	2	1	Bit 0
Read:	0	0	0	0	IRQF1	0	IMASK1	MODE1
Write:	R	R	R	R	R	ACK1		
Reset:	0	0	0	0	0	0	0	0

R = Reserved

**Figure 15-3. IRQ Status and Control Register (ISCR)**

#### IRQ1F — IRQ1 Flag Bit

This read-only status bit is high when the IRQ1 interrupt is pending.

1 =  $\overline{\text{IRQ1}}$  interrupt pending

0 =  $\overline{\text{IRQ1}}$  interrupt not pending

#### ACK1 — IRQ1 Interrupt Request Acknowledge Bit

Writing a logic 1 to this write-only bit clears the IRQ1 latch. ACK1 always reads as logic 0. Reset clears ACK1.

#### IMASK1 — IRQ1 Interrupt Mask Bit

Writing a logic 1 to this read/write bit disables IRQ1 interrupt requests. Reset clears IMASK1.

1 = IRQ1 interrupt requests disabled

0 = IRQ1 interrupt requests enabled

#### MODE1 — IRQ1 Edge/Level Select Bit

This read/write bit controls the triggering sensitivity of the  $\overline{\text{IRQ}}$  pin. Reset clears MODE1.

1 =  $\overline{\text{IRQ}}$  interrupt requests on falling edges and low levels

0 =  $\overline{\text{IRQ}}$  interrupt requests on falling edges only



## External Interrupt (IRQ)



## Section 16. Serial Communications Interface Module (SCI)

### 16.1 Contents

16.2	Introduction .....	212
16.3	Features .....	212
16.4	Pin Name Conventions .....	213
16.5	Functional Description .....	213
16.5.1	Data Format .....	216
16.5.2	Transmitter .....	216
16.5.2.1	Character Length .....	216
16.5.2.2	Character Transmission .....	217
16.5.2.3	Break Characters .....	220
16.5.2.4	Idle Characters .....	220
16.5.2.5	Inversion of Transmitted Output .....	221
16.5.2.6	Transmitter Interrupts .....	221
16.5.3	Receiver .....	221
16.5.3.1	Character Length .....	224
16.5.3.2	Character Reception .....	224
16.5.3.3	Data Sampling .....	224
16.5.3.4	Framing Errors .....	227
16.5.3.5	Baud Rate Tolerance .....	227
16.5.3.6	Receiver Wakeup .....	230
16.5.3.7	Receiver Interrupts .....	231
16.5.3.8	Error Interrupts .....	231
16.6	Low-Power Modes .....	232
16.6.1	Wait Mode .....	232
16.6.2	Stop Mode .....	232
16.7	SCI During Break Module Interrupts .....	233
16.8	I/O Signals .....	233
16.8.1	PTE0/SCTxD (Transmit Data) .....	233
16.8.2	PTE1/SCRxD (Receive Data) .....	234

16.9	I/O Registers . . . . .	234
16.9.1	SCI Control Register 1 . . . . .	234
16.9.2	SCI Control Register 2 . . . . .	237
16.9.3	SCI Control Register 3 . . . . .	241
16.9.4	SCI Status Register 1 . . . . .	243
16.9.5	SCI Status Register 2 . . . . .	247
16.9.6	SCI Data Register . . . . .	248
16.9.7	SCI Baud Rate Register . . . . .	249

## 16.2 Introduction

The SCI allows asynchronous communications with peripheral devices and other MCUs.

## 16.3 Features

The SCI module's features include:

- Full Duplex Operation
- Standard Mark/Space Non-Return-to-Zero (NRZ) Format
- 32 Programmable Baud Rates
- Programmable 8-Bit or 9-Bit Character Length
- Separately Enabled Transmitter and Receiver
- Separate Receiver and Transmitter CPU Interrupt Requests
- Programmable Transmitter Output Polarity
- Two Receiver Wakeup Methods:
  - Idle Line Wakeup
  - Address Mark Wakeup
- Interrupt-Driven Operation with Eight Interrupt Flags:
  - Transmitter Empty
  - Transmission Complete
  - Receiver Full
  - Idle Receiver Input

- Receiver Overrun
- Noise Error
- Framing Error
- Parity Error
- Receiver Framing Error Detection
- Hardware Parity Checking
- 1/16 Bit-Time Noise Detection

## 16.4 Pin Name Conventions

The generic names of the SCI input/output (I/O) pins are:

- RxD (receive data)
- TxD (transmit data)

SCI I/O lines are implemented by sharing parallel I/O port pins. The full name of an SCI input or output reflects the name of the shared port pin.

**Table 16-1** shows the full names and the generic names of the SCI I/O pins. The generic pin names appear in the text of this section.

**Table 16-1. Pin Name Conventions**

<b>Generic Pin Names</b>	RxD	TxD
<b>Full Pin Names</b>	PTE1/SCRxD	PTE0/SCTxD

## 16.5 Functional Description

**Figure 16-1** shows the structure of the SCI module. The SCI allows full-duplex, asynchronous, NRZ serial communication between the MCU and remote devices, including other MCUs. The transmitter and receiver of the SCI operate independently, although they use the same baud rate generator. During normal operation, the CPU monitors the status of the SCI, writes the data to be transmitted, and processes received data.

# Serial Communications Interface Module (SCI)

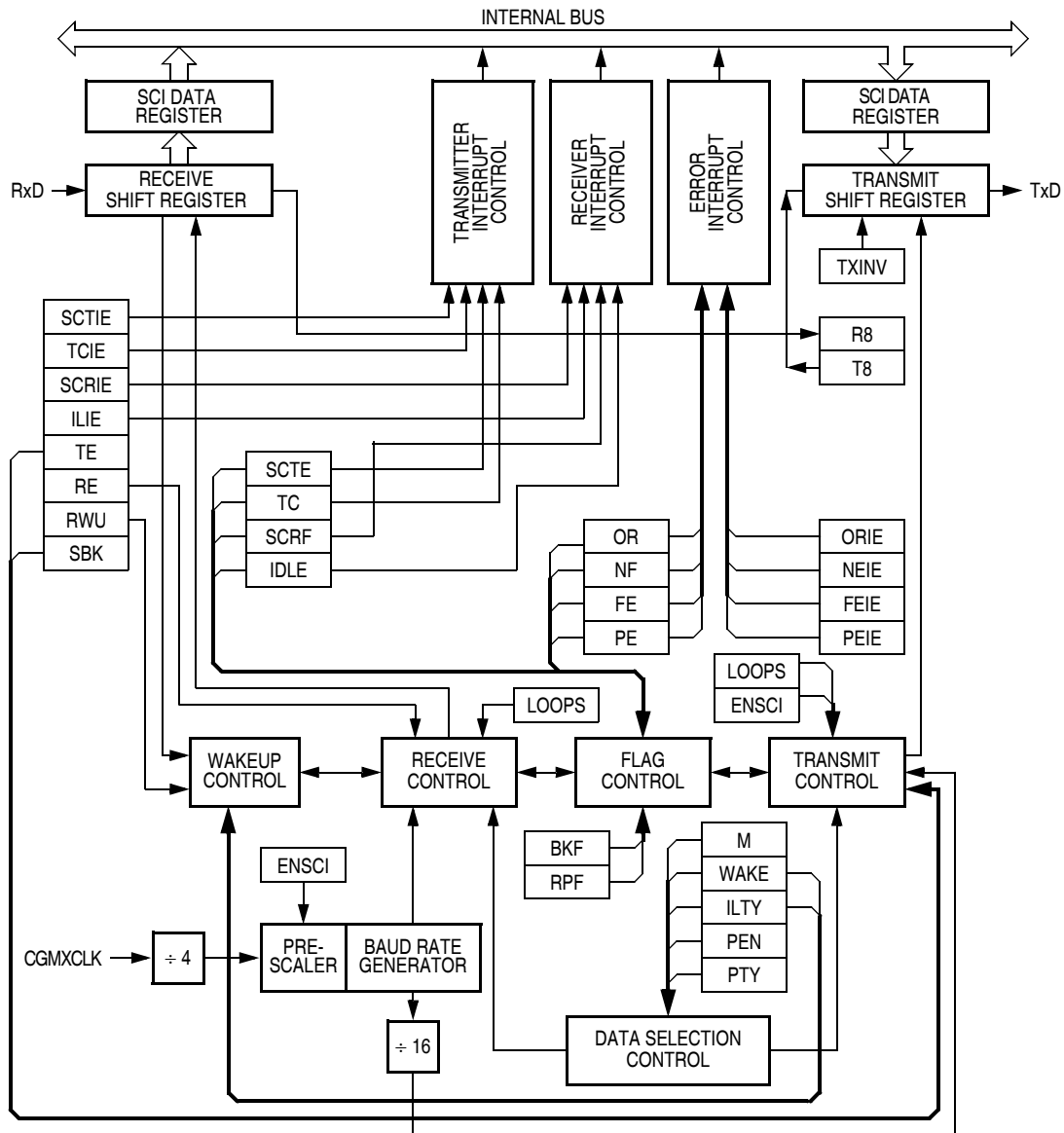


Figure 16-1. SCI Module Block Diagram



**Table 16-2. SCI I/O Register Summary**

Register Name	Bit 7	6	5	4	3	2	1	Bit 0
SCI Control Register 1 (SCC1)	Read:	LOOPS	ENSCI	TXINV	M	WAKE	ILTY	PTY
	Write:							
	Reset:	0	0	0	0	0	0	0
SCI Control Register 2 (SCC2)	Read:	SCTIE	TCIE	SCRIE	ILIE	TE	RE	RWU
	Write:							SBK
	Reset:	0	0	0	0	0	0	0
SCI Control Register 3 (SCC3)	Read:	R8	T8	R	R	ORIE	NEIE	FEIE
	Write:							PEIE
	Reset:	U	U	0	0	0	0	0
SCI Status Register 1 (SCS1)	Read:	SCTE	TC	SCRIF	IDLE	OR	NF	FE
	Write:							PE
	Reset:	1	1	0	0	0	0	0
SCI Status Register 2 (SCS2)	Read:						BKF	RPF
	Write:							
	Reset:	0	0	0	0	0	0	0
SCI Data Register (SCDR)	Read:	R7	R6	R5	R4	R3	R2	R1
	Write:	T7	T6	T5	T4	T3	T2	T1
	Reset:	Unaffected by Reset						
SCI Baud Rate Register (SCBR)	Read:			SCP1	SCP0	R	SCR2	SCR1
	Write:						SCR0	SCR0
	Reset:	0	0	0	0	0	0	0

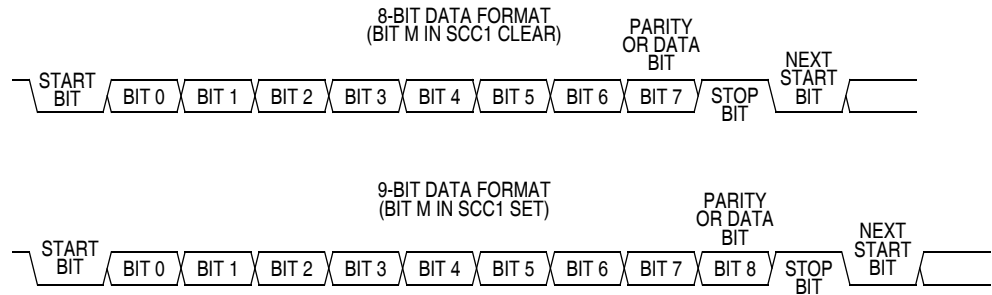
= Unimplemented     
 U = Unaffected     
 R = Reserved

**Table 16-3. SCI I/O Register Address Summary**

<b>Register</b>	SCC1	SCC2	SCC3	SCS1	SCS2	SCDR	SCBR
<b>Address</b>	\$0013	\$0014	\$0015	\$0016	\$0017	\$0018	\$0019

## 16.5.1 Data Format

The SCI uses the standard non-return-to-zero mark/space data format illustrated in [Figure 16-2](#).



**Figure 16-2. SCI Data Formats**

## 16.5.2 Transmitter

[Figure 16-3](#) shows the structure of the SCI transmitter.

### 16.5.2.1 Character Length

The transmitter can accommodate either 8-bit or 9-bit data. The state of the M bit in SCI control register 1 (SCC1) determines character length. When transmitting 9-bit data, bit T8 in SCI control register 3 (SCC3) is the ninth bit (bit 8).

### 16.5.2.2 Character Transmission

During an SCI transmission, the transmit shift register shifts a character out to the TxD pin. The SCI data register (SCDR) is the write-only buffer between the internal data bus and the transmit shift register. To initiate an SCI transmission:

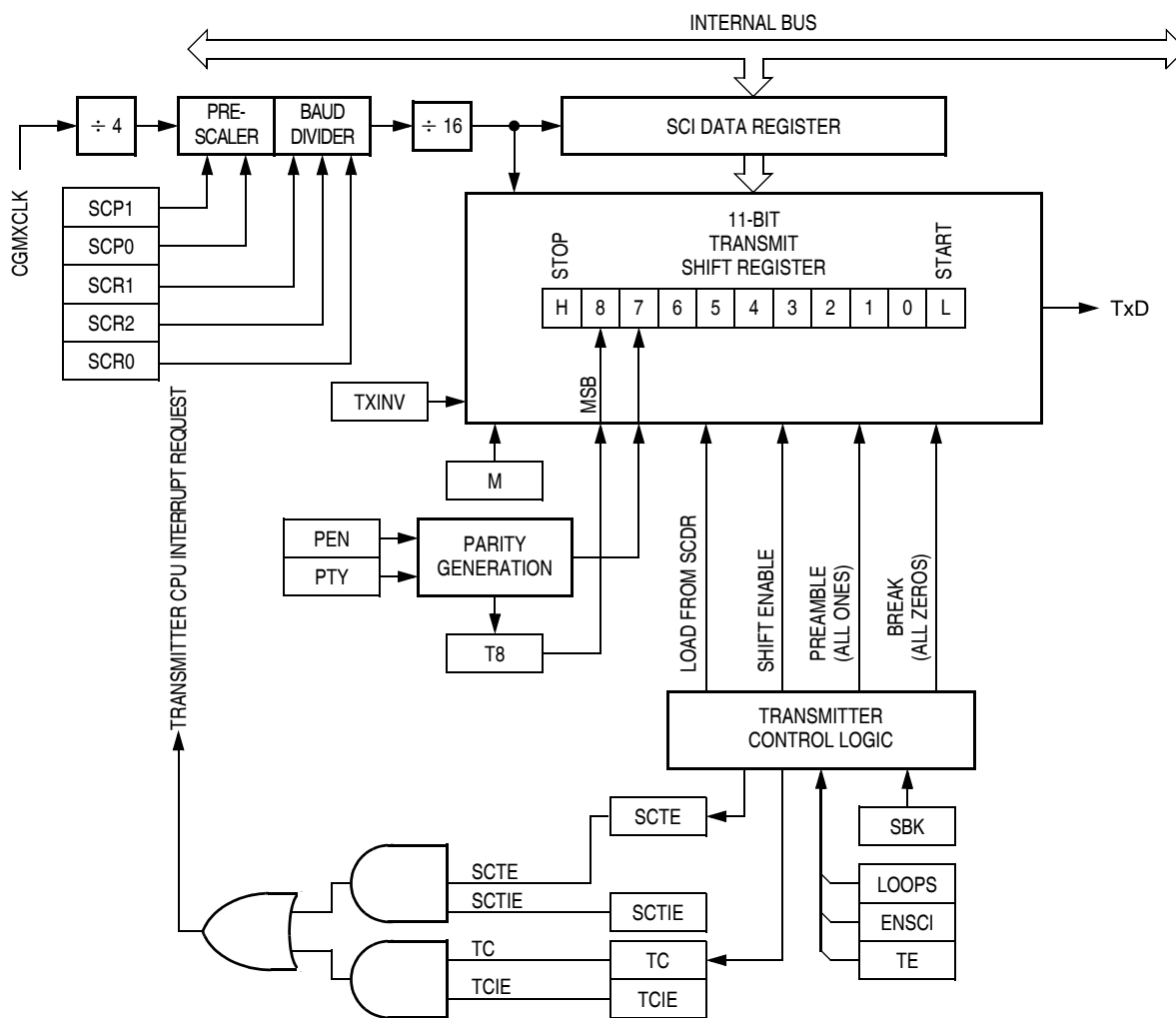
1. Enable the SCI by writing a logic 1 to the enable SCI bit (ENSCI) in SCI control register 1 (SCC1).
2. Enable the transmitter by writing a logic 1 to the transmitter enable bit (TE) in SCI control register 2 (SCC2).
3. Clear the SCI transmitter empty bit (SCTE) by first reading SCI status register 1 (SCS1) and then writing to the SCDR.
4. Repeat step 3 for each subsequent transmission.

At the start of a transmission, transmitter control logic automatically loads the transmit shift register with a preamble of logic 1s. After the preamble shifts out, control logic transfers the SCDR data into the transmit shift register. A logic 0 start bit automatically goes into the least significant bit position of the transmit shift register. A logic 1 stop bit goes into the most significant bit position.

The SCI transmitter empty bit, SCTE, in SCS1 becomes set when the SCDR transfers a byte to the transmit shift register. The SCTE bit indicates that the SCDR can accept new data from the internal data bus. If the SCI transmit interrupt enable bit, SCTIE, in SCC2 is also set, the SCTE bit generates a transmitter CPU interrupt request.

When the transmit shift register is not transmitting a character, the TxD pin goes to the idle condition, logic 1. If at any time software clears the ENSCI bit in SCI control register 1 (SCC1), the transmitter and receiver relinquish control of the port E pins.





**Figure 16-3. SCI Transmitter**



# Serial Communications Interface Module (SCI)

**Table 16-4. SCI Transmitter I/O Register Summary**

Register Name	Bit 7	6	5	4	3	2	1	Bit 0
SCI Control Register 1 (SCC1)	Read:	LOOPS	ENSCI	TXINV	M	WAKE	ILTY	PTY
	Write:							
	Reset:	0	0	0	0	0	0	0
SCI Control Register 2 (SCC2)	Read:	SCTIE	TCIE	SCRIE	ILIE	TE	RE	RWU
	Write:							SBK
	Reset:	0	0	0	0	0	0	0
SCI Control Register 3 (SCC3)	Read:	R8	T8	R	R	ORIE	NEIE	FEIE
	Write:							PEIE
	Reset:	U	U	0	0	0	0	0
SCI Status Register 1 (SCS1)	Read:	SCTE	TC	SCRf	IDLE	OR	NF	FE
	Write:							PE
	Reset:	1	1	0	0	0	0	0
SCI Status Register 2 (SCS2)	Read:						BKF	RPF
	Write:							
	Reset:	0	0	0	0	0	0	0
SCI Data Register (SCDR)	Read:	R7	R6	R5	R4	R3	R2	R1
	Write:	T7	T6	T5	T4	T3	T2	T1
	Reset:	Unaffected by Reset						
SCI Baud Rate Register (SCBR)	Read:			SCP1	SCP0	R	SCR2	SCR1
	Write:						SCR0	SCR0
	Reset:	0	0	0	0	0	0	0

= Unimplemented   
 U = Unaffected   
 R = Reserved

**Table 16-5. SCI Transmitter I/O Address Summary**

Register	SCC1	SCC2	SCC3	SCS1	SCDR	SCBR
Address	\$0013	\$0014	\$0015	\$0016	\$0018	\$0019

### 16.5.2.3 Break Characters

Writing a logic 1 to the send break bit, SBK, in SCC2 loads the transmit shift register with a break character. A break character contains all logic 0s and has no start, stop, or parity bit. Break character length depends on the M bit in SCC1. As long as SBK is at logic 1, transmitter logic continuously loads break characters into the transmit shift register. After software clears the SBK bit, the shift register finishes transmitting the last break character and then transmits at least one logic 1. The automatic logic 1 at the end of a break character guarantees the recognition of the start bit of the next character.

The SCI recognizes a break character when a start bit is followed by eight or nine logic 0 data bits and a logic 0 where the stop bit should be. Receiving a break character has the following effects on SCI registers:

- Sets the framing error bit (FE) in SCS1
- Sets the SCI receiver full bit (SCRF) in SCS1
- Clears the SCI data register (SCDR)
- Clears the R8 bit in SCC3
- Sets the break flag bit (BKF) in SCS2
- May set the overrun (OR), noise flag (NF), parity error (PE), or reception in progress flag (RPF) bits

### 16.5.2.4 Idle Characters

An idle character contains all logic 1s and has no start, stop, or parity bit. Idle character length depends on the M bit in SCC1. The preamble is a synchronizing idle character that begins every transmission.

If the TE bit is cleared during a transmission, the TxD pin becomes idle after completion of the transmission in progress. Clearing and then setting the TE bit during a transmission queues an idle character to be sent after the character currently being transmitted.

**NOTE:** *When queueing an idle character, return the TE bit to logic 1 before the stop bit of the current character shifts out to the TxD pin. Setting TE after the stop bit appears on TxD causes data previously written to the SCDR to be lost.*

*A good time to toggle the TE bit for a queued idle character is when the SCTE bit becomes set and just before writing the next byte to the SCDR.*

#### 16.5.2.5 Inversion of Transmitted Output

The transmit inversion bit (TXINV) in SCI control register 1 (SCC1) reverses the polarity of transmitted data. All transmitted values, including idle, break, start, and stop bits, are inverted when TXINV is at logic 1. (See [16.9.1 SCI Control Register 1](#).)

#### 16.5.2.6 Transmitter Interrupts

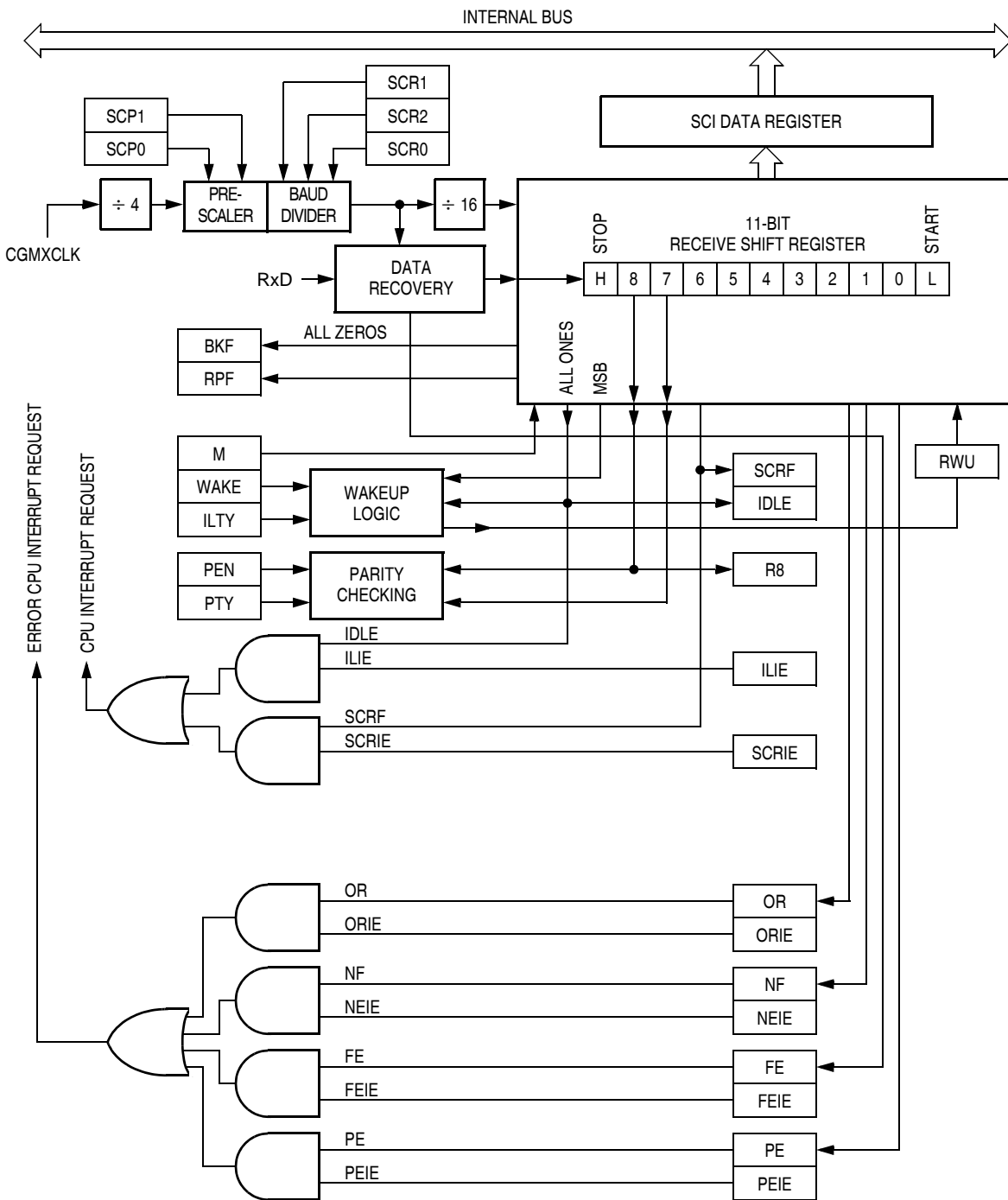
The following conditions can generate CPU interrupt requests from the SCI transmitter:

- SCI transmitter empty (SCTE) — The SCTE bit in SCS1 indicates that the SCDR has transferred a character to the transmit shift register. SCTE can generate a transmitter CPU interrupt request. Setting the SCI transmit interrupt enable bit, SCTIE, in SCC2 enables the SCTE bit to generate transmitter CPU interrupt requests.
- Transmission complete (TC) — The TC bit in SCS1 indicates that the transmit shift register and the SCDR are empty and that no break or idle character has been generated. The transmission complete interrupt enable bit, TCIE, in SCC2 enables the TC bit to generate transmitter CPU interrupt requests.

### 16.5.3 Receiver

[Figure 16-4](#) shows the structure of the SCI receiver.

# Serial Communications Interface Module (SCI)



**Figure 16-4. SCI Receiver Block Diagram**



**Table 16-6. SCI Receiver I/O Register Summary**

Register Name	Bit 7	6	5	4	3	2	1	Bit 0
SCI Control Register 1 (SCC1)	Read:	LOOPS	ENSCI	TXINV	M	WAKE	ILTY	PTY
	Write:							
	Reset:	0	0	0	0	0	0	0
SCI Control Register 2 (SCC2)	Read:	SCTIE	TCIE	SCRIE	ILIE	TE	RE	RWU
	Write:							SBK
	Reset:	0	0	0	0	0	0	0
SCI Control Register 3 (SCC3)	Read:	R8	T8	R	R	ORIE	NEIE	FEIE
	Write:							PEIE
	Reset:	U	U	0	0	0	0	0
SCI Status Register 1 (SCS1)	Read:	SCTE	TC	SCRf	IDLE	OR	NF	FE
	Write:							PE
	Reset:	1	1	0	0	0	0	0
SCI Status Register 2 (SCS2)	Read:						BKF	RPF
	Write:							
	Reset:	0	0	0	0	0	0	0
SCI Data Register (SCDR)	Read:	R7	R6	R5	R4	R3	R2	R1
	Write:	T7	T6	T5	T4	T3	T2	T1
	Reset:	Unaffected by Reset						
SCI Baud Rate Register (SCBR)	Read:			SCP1	SCP0	R	SCR2	SCR1
	Write:						SCR0	SCR0
	Reset:	0	0	0	0	0	0	0

= Unimplemented   
 U = Unaffected   
 R = Reserved

**Table 16-7. SCI Receiver I/O Address Summary**

Register	SCC1	SCC2	SCC3	SCS1	SCS2	SCDR	SCBR
Address	\$0013	\$0014	\$0015	\$0016	\$0017	\$0018	\$0019



### 16.5.3.1 Character Length

The receiver can accommodate either 8-bit or 9-bit data. The state of the M bit in SCI control register 1 (SCC1) determines character length. When receiving 9-bit data, bit R8 in SCI control register 2 (SCC2) is the ninth bit (bit 8). When receiving 8-bit data, bit R8 is a copy of the eighth bit (bit 7).

### 16.5.3.2 Character Reception

During an SCI reception, the receive shift register shifts characters in from the RxD pin. The SCI data register (SCDR) is the read-only buffer between the internal data bus and the receive shift register.

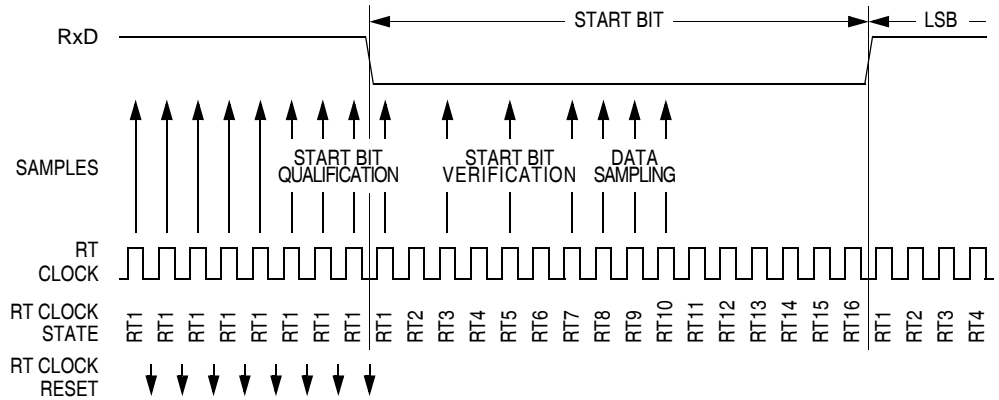
After a complete character shifts into the receive shift register, the data portion of the character transfers to the SCDR. The SCI receiver full bit, SCRF, in SCI status register 1 (SCS1) becomes set, indicating that the received byte can be read. If the SCI receive interrupt enable bit, SCRIE, in SCC2 is also set, the SCRF bit generates a receiver CPU interrupt request.

### 16.5.3.3 Data Sampling

The receiver samples the RxD pin at the RT clock rate. The RT clock is an internal signal with a frequency 16 times the baud rate. To adjust for baud rate mismatch, the RT clock is resynchronized at the following times (see [Figure 16-5](#)):

- After every start bit
- After the receiver detects a data bit change from logic 1 to logic 0 (after the majority of data bit samples at RT8, RT9, and RT10 returns a valid logic 1 and the majority of the next RT8, RT9, and RT10 samples returns a valid logic 0)

To locate the start bit, data recovery logic does an asynchronous search for a logic 0 preceded by three logic 1s. When the falling edge of a possible start bit occurs, the RT clock begins to count to 16.



**Figure 16-5. Receiver Data Sampling**

To verify the start bit and to detect noise, data recovery logic takes samples at RT3, RT5, and RT7. [Table 16-8](#) summarizes the results of the start bit verification samples.

**Table 16-8. Start Bit Verification**

RT3, RT5, and RT7 Samples	Start Bit Verification	Noise Flag
000	Yes	0
001	Yes	1
010	Yes	1
011	No	0
100	Yes	1
101	No	0
110	No	0
111	No	0

If start bit verification is not successful, the RT clock is reset and a new search for a start bit begins.

To determine the value of a data bit and to detect noise, recovery logic takes samples at RT8, RT9, and RT10. [Table 16-9](#) summarizes the results of the data bit samples.

**Table 16-9. Data Bit Recovery**

RT8, RT9, and RT10 Samples	Data Bit Determination	Noise Flag
000	0	0
001	0	1
010	0	1
011	1	1
100	0	1
101	1	1
110	1	1
111	1	0

**NOTE:** *The RT8, RT9, and RT10 samples do not affect start bit verification. If any or all of the RT8, RT9, and RT10 start bit samples are logic 1s following a successful start bit verification, the noise flag (NF) is set and the receiver assumes that the bit is a start bit.*

To verify a stop bit and to detect noise, recovery logic takes samples at RT8, RT9, and RT10. [Table 16-10](#) summarizes the results of the stop bit samples.

**Table 16-10. Stop Bit Recovery**

RT8, RT9, and RT10 Samples	Framing Error Flag	Noise Flag
000	1	0
001	1	1
010	1	1
011	0	1
100	1	1
101	0	1
110	0	1
111	0	0

## 16.5.3.4 Framing Errors

If the data recovery logic does not detect a logic 1 where the stop bit should be in an incoming character, it sets the framing error bit, FE, in SCS1. A break character also sets the FE bit because a break character has no stop bit. The FE bit is set at the same time that the SCRF bit is set.

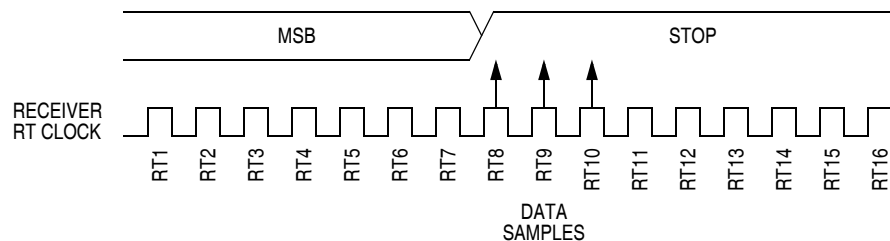
## 16.5.3.5 Baud Rate Tolerance

A transmitting device may be operating at a baud rate below or above the receiver baud rate. Accumulated bit time misalignment can cause one of the three stop bit data samples to fall outside the actual stop bit. Then a noise error occurs. If more than one of the samples is outside the stop bit, a framing error occurs. In most applications, the baud rate tolerance is much more than the degree of misalignment that is likely to occur.

As the receiver samples an incoming character, it resynchronizes the RT clock on any valid falling edge within the character. Resynchronization within characters corrects misalignments between transmitter bit times and receiver bit times.

### Slow Data Tolerance

**Figure 16-6** shows how much a slow received character can be misaligned without causing a noise error or a framing error. The slow stop bit begins at RT8 instead of RT1 but arrives in time for the stop bit data samples at RT8, RT9, and RT10.



**Figure 16-6. Slow Data**

For an 8-bit character, data sampling of the stop bit takes the receiver 9 bit times  $\times$  16 RT cycles + 10 RT cycles = 154 RT cycles.

With the misaligned character shown in [Figure 16-6](#), the receiver counts 154 RT cycles at the point when the count of the transmitting device is 9 bit times  $\times$  16 RT cycles + 3 RT cycles = 147 RT cycles.

The maximum percent difference between the receiver count and the transmitter count of a slow 8-bit character with no errors is

$$\left| \frac{154 - 147}{154} \right| \times 100 = 4.54\%$$

For a 9-bit character, data sampling of the stop bit takes the receiver 10 bit times  $\times$  16 RT cycles + 10 RT cycles = 170 RT cycles.

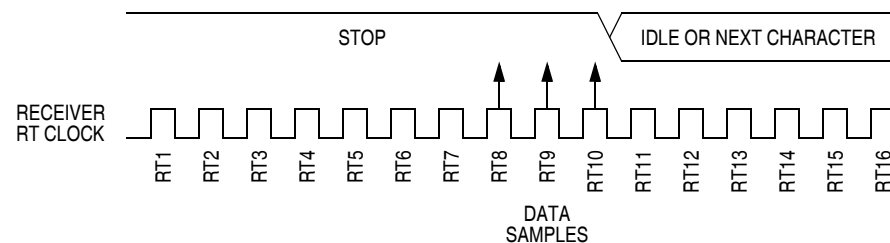
With the misaligned character shown in [Figure 16-6](#), the receiver counts 170 RT cycles at the point when the count of the transmitting device is 10 bit times  $\times$  16 RT cycles + 3 RT cycles = 163 RT cycles.

The maximum percent difference between the receiver count and the transmitter count of a slow 9-bit character with no errors is

$$\left| \frac{170 - 163}{170} \right| \times 100 = 4.12\%$$

### Fast Data Tolerance

[Figure 16-7](#) shows how much a fast received character can be misaligned without causing a noise error or a framing error. The fast stop bit ends at RT10 instead of RT16 but is still there for the stop bit data samples at RT8, RT9, and RT10.



**Figure 16-7. Fast Data**

For an 8-bit character, data sampling of the stop bit takes the receiver 9 bit times  $\times$  16 RT cycles + 10 RT cycles = 154 RT cycles.

With the misaligned character shown in [Figure 16-7](#), the receiver counts 154 RT cycles at the point when the count of the transmitting device is 10 bit times  $\times$  16 RT cycles = 160 RT cycles.

The maximum percent difference between the receiver count and the transmitter count of a fast 8-bit character with no errors is

$$\left| \frac{154 - 160}{154} \right| \times 100 = 3.90\%.$$

For a 9-bit character, data sampling of the stop bit takes the receiver 10 bit times  $\times$  16 RT cycles + 10 RT cycles = 170 RT cycles.

With the misaligned character shown in [Figure 16-7](#), the receiver counts 170 RT cycles at the point when the count of the transmitting device is 11 bit times  $\times$  16 RT cycles = 176 RT cycles.

The maximum percent difference between the receiver count and the transmitter count of a fast 9-bit character with no errors is

$$\left| \frac{170 - 176}{170} \right| \times 100 = 3.53\%.$$

### 16.5.3.6 Receiver Wakeup

So that the MCU can ignore transmissions intended only for other receivers in multiple-receiver systems, the receiver can be put into a standby state. Setting the receiver wakeup bit, RWU, in SCC2 puts the receiver into a standby state during which receiver interrupts are disabled.

Depending on the state of the WAKE bit in SCC1, either of two conditions on the RxD pin can bring the receiver out of the standby state:

- Address mark — An address mark is a logic 1 in the most significant bit position of a received character. When the WAKE bit is set, an address mark wakes the receiver from the standby state by clearing the RWU bit. The address mark also sets the SCI receiver full bit, SCRF. Software can then compare the character containing the address mark to the user-defined address of the receiver. If they are the same, the receiver remains awake and processes the characters that follow. If they are not the same, software can set the RWU bit and put the receiver back into the standby state.
- Idle input line condition — When the WAKE bit is clear, an idle character on the RxD pin wakes the receiver from the standby state by clearing the RWU bit. The idle character that wakes the receiver does not set the receiver idle bit, IDLE, or the SCI receiver full bit, SCRF. The idle line type bit, ILTY, determines whether the receiver begins counting logic 1s as idle character bits after the start bit or after the stop bit.

**NOTE:** *With the WAKE bit clear, setting the RWU bit after the RxD pin has been idle may cause the receiver to wake up immediately.*

### 16.5.3.7 Receiver Interrupts

The following sources can generate CPU interrupt requests from the SCI receiver:

- SCI receiver full (SCRF) — The SCRF bit in SCS1 indicates that the receive shift register has transferred a character to the SCDR. SCRF can generate a receiver CPU interrupt request. Setting the SCI receive interrupt enable bit, SCRIE, in SCC2 enables the SCRF bit to generate receiver CPU interrupts.
- Idle input (IDLE) — The IDLE bit in SCS1 indicates that 10 or 11 consecutive logic 1s shifted in from the RxD pin. The idle line interrupt enable bit, ILIE, in SCC2 enables the IDLE bit to generate CPU interrupt requests.

### 16.5.3.8 Error Interrupts

The following receiver error flags in SCS1 can generate CPU interrupt requests:

- Receiver overrun (OR) — The OR bit indicates that the receive shift register shifted in a new character before the previous character was read from the SCDR. The previous character remains in the SCDR, and the new character is lost. The overrun interrupt enable bit, ORIE, in SCC3 enables OR to generate SCI error CPU interrupt requests.
- Noise flag (NF) — The NF bit is set when the SCI detects noise on incoming data or break characters, including start, data, and stop bits. The noise error interrupt enable bit, NEIE, in SCC3 enables NF to generate SCI error CPU interrupt requests.
- Framing error (FE) — The FE bit in SCS1 is set when a logic 0 occurs where the receiver expects a stop bit. The framing error interrupt enable bit, FEIE, in SCC3 enables FE to generate SCI error CPU interrupt requests.
- Parity error (PE) — The PE bit in SCS1 is set when the SCI detects a parity error in incoming data. The parity error interrupt enable bit, PEIE, in SCC3 enables PE to generate SCI error CPU interrupt requests.



## 16.6 Low-Power Modes

The WAIT and STOP instructions put the MCU in low-power standby modes.

### 16.6.1 Wait Mode

The SCI module remains active in wait mode. Any enabled CPU interrupt request from the SCI module can bring the MCU out of wait mode.

If SCI module functions are not required during wait mode, reduce power consumption by disabling the module before executing the WAIT instruction.

### 16.6.2 Stop Mode

The SCI module is inactive in stop mode. The STOP instruction does not affect SCI register states. SCI module operation resumes after the MCU exits stop mode.

Because the internal clock is inactive during stop mode, entering stop mode during an SCI transmission or reception results in invalid data.

## 16.7 SCI During Break Module Interrupts

The BCFE bit in the break flag control register (BFCR) enables software to clear status bits during the break state. (See [Section 11. Break Module \(BRK\)](#).)

To allow software to clear status bits during a break interrupt, write a logic 1 to the BCFE bit. If a status bit is cleared during the break state, it remains cleared when the MCU exits the break state.

To protect status bits during the break state, write a logic 0 to the BCFE bit. With BCFE at logic 0 (its default state), software can read and write I/O registers during the break state without affecting status bits. Some status bits have a two-step read/write clearing procedure. If software does the first step on such a bit before the break, the bit cannot change during the break state as long as BCFE is at logic 0. After the break, doing the second step clears the status bit.

## 16.8 I/O Signals

Port E shares two of its pins with the SCI module. The two SCI I/O pins are:

- PTE0/SCTxD — Transmit data
- PTE1/SCRxD — Receive data

### 16.8.1 PTE0/SCTxD (Transmit Data)

The PTE0/SCTxD pin is the serial data output from the SCI transmitter. The SCI shares the PTE0/SCTxD pin with port E. When the SCI is enabled, the PTE0/SCTxD pin is an output regardless of the state of the DDRE2 bit in data direction register E (DDRE).

### 16.8.2 PTE1/SCRxD (Receive Data)

The PTE1/SCRxD pin is the serial data input to the SCI receiver. The SCI shares the PTE1/SCRxD pin with port E. When the SCI is enabled, the PTE1/SCRxD pin is an input regardless of the state of the DDRE1 bit in data direction register E (DDRE).

## 16.9 I/O Registers

The following I/O registers control and monitor SCI operation:

- SCI control register 1 (SCC1)
- SCI control register 2 (SCC2)
- SCI control register 3 (SCC3)
- SCI status register 1 (SCS1)
- SCI status register 2 (SCS2)
- SCI data register (SCDR)
- SCI baud rate register (SCBR)

### 16.9.1 SCI Control Register 1

SCI control register 1:

- Enables loop mode operation
- Enables the SCI
- Controls output polarity
- Controls character length
- Controls SCI wakeup method
- Controls idle character detection
- Enables parity function
- Controls parity type

Address: \$0013

	Bit 7	6	5	4	3	2	1	Bit 0
Read:	LOOPS	ENSCI	TXINV	M	WAKE	ILTY	PEN	PTY
Write:								
Reset:	0	0	0	0	0	0	0	0

**Figure 16-8. SCI Control Register 1 (SCC1)**

### LOOPS — Loop Mode Select Bit

This read/write bit enables loop mode operation. In loop mode the RxD pin is disconnected from the SCI, and the transmitter output goes into the receiver input. Both the transmitter and the receiver must be enabled to use loop mode. Reset clears the LOOPS bit.

- 1 = Loop mode enabled
- 0 = Normal operation enabled

### ENSCI — Enable SCI Bit

This read/write bit enables the SCI and the SCI baud rate generator. Clearing ENSCI sets the SCTE and TC bits in SCI status register 1 and disables transmitter interrupts. Reset clears the ENSCI bit.

- 1 = SCI enabled
- 0 = SCI disabled

### TXINV — Transmit Inversion Bit

This read/write bit reverses the polarity of transmitted data. Reset clears the TXINV bit.

- 1 = Transmitter output inverted
- 0 = Transmitter output not inverted

**NOTE:** *Setting the TXINV bit inverts all transmitted values, including idle, break, start, and stop bits.*

### M — Mode (Character Length) Bit

This read/write bit determines whether SCI characters are eight or nine bits long. (See [Table 16-11](#).) The ninth bit can serve as an extra stop bit, as a receiver wakeup signal, or as a parity bit. Reset clears the M bit.

- 1 = 9-bit SCI characters
- 0 = 8-bit SCI characters

### WAKE — Wakeup Condition Bit

This read/write bit determines which condition wakes up the SCI: a logic 1 (address mark) in the most significant bit position of a received character or an idle condition on the RxD pin. Reset clears the WAKE bit.

- 1 = Address mark wakeup
- 0 = Idle line wakeup

### ILTY — Idle Line Type Bit

This read/write bit determines when the SCI starts counting logic 1s as idle character bits. The counting begins either after the start bit or after the stop bit. If the count begins after the start bit, then a string of logic 1s preceding the stop bit may cause false recognition of an idle character. Beginning the count after the stop bit avoids false idle character recognition, but requires properly synchronized transmissions. Reset clears the ILTY bit.

- 1 = Idle character bit count begins after stop bit
- 0 = Idle character bit count begins after start bit

### PEN — Parity Enable Bit

This read/write bit enables the SCI parity function. (See [Table 16-11](#).) When enabled, the parity function inserts a parity bit in the most significant bit position. (See [Figure 16-2](#).) Reset clears the PEN bit.

- 1 = Parity function enabled
- 0 = Parity function disabled

## PTY — Parity Bit

This read/write bit determines whether the SCI generates and checks for odd parity or even parity. (See [Table 16-11](#).) Reset clears the PTY bit.

- 1 = Odd parity
- 0 = Even parity

**NOTE:** *Changing the PTY bit in the middle of a transmission or reception can generate a parity error.*

**Table 16-11. Character Format Selection**

Control Bits		Character Format				
M	PEN:PTY	Start Bits	Data Bits	Parity	Stop Bits	Character Length
0	0X	1	8	None	1	10 Bits
1	0X	1	9	None	1	11 Bits
0	10	1	7	Even	1	10 Bits
0	11	1	7	Odd	1	10 Bits
1	10	1	8	Even	1	11 Bits
1	11	1	8	Odd	1	11 Bits

## 16.9.2 SCI Control Register 2

SCI control register 2:

- Enables the following CPU interrupt requests:
  - Enables the SCTE bit to generate transmitter CPU interrupt requests
  - Enables the TC bit to generate transmitter CPU interrupt requests
  - Enables the SCRF bit to generate receiver CPU interrupt requests
  - Enables the IDLE bit to generate receiver CPU interrupt requests

- Enables the transmitter
- Enables the receiver
- Enables SCI wakeup
- Transmits SCI break characters

Address: \$0014

	Bit 7	6	5	4	3	2	1	Bit 0
Read:	SCTIE	TCIE	SCRIE	ILIE	TE	RE	RWU	SBK
Write:								
Reset:	0	0	0	0	0	0	0	0

**Figure 16-9. SCI Control Register 2 (SCC2)**

#### SCTIE — SCI Transmit Interrupt Enable Bit

This read/write bit enables the SCTE bit to generate SCI transmitter CPU interrupt requests. Setting the SCTIE bit in SCC3 enables the SCTE bit to generate CPU interrupt requests. Reset clears the SCTIE bit.

- 1 = SCTE enabled to generate CPU interrupt
- 0 = SCTE not enabled to generate CPU interrupt

#### TCIE — Transmission Complete Interrupt Enable Bit

This read/write bit enables the TC bit to generate SCI transmitter CPU interrupt requests. Reset clears the TCIE bit.

- 1 = TC enabled to generate CPU interrupt requests
- 0 = TC not enabled to generate CPU interrupt requests

## SCRIE — SCI Receive Interrupt Enable Bit

This read/write bit enables the SCRF bit to generate SCI receiver CPU interrupt requests. Setting the SCRIE bit in SCC3 enables the SCRF bit to generate CPU interrupt requests. Reset clears the SCRIE bit.

- 1 = SCRF enabled to generate CPU interrupt
- 0 = SCRF not enabled to generate CPU interrupt

## ILIE — Idle Line Interrupt Enable Bit

This read/write bit enables the IDLE bit to generate SCI receiver CPU interrupt requests. Reset clears the ILIE bit.

- 1 = IDLE enabled to generate CPU interrupt requests
- 0 = IDLE not enabled to generate CPU interrupt requests

## TE — Transmitter Enable Bit

Setting this read/write bit begins the transmission by sending a preamble of 10 or 11 logic 1s from the transmit shift register to the TxD pin. If software clears the TE bit, the transmitter completes any transmission in progress before the TxD returns to the idle condition (logic 1). Clearing and then setting TE during a transmission queues an idle character to be sent after the character currently being transmitted. Reset clears the TE bit.

- 1 = Transmitter enabled
- 0 = Transmitter disabled

**NOTE:** *Writing to the TE bit is not allowed when the enable SCI bit (ENSCI) is clear. ENSCI is in SCI control register 1.*



#### RE — Receiver Enable Bit

Setting this read/write bit enables the receiver. Clearing the RE bit disables the receiver but does not affect receiver interrupt flag bits.

Reset clears the RE bit.

1 = Receiver enabled

0 = Receiver disabled

**NOTE:** *Writing to the RE bit is not allowed when the enable SCI bit (ENSCI) is clear. ENSCI is in SCI control register 1.*

#### RWU — Receiver Wakeup Bit

This read/write bit puts the receiver in a standby state during which receiver interrupts are disabled. The WAKE bit in SCC1 determines whether an idle input or an address mark brings the receiver out of the standby state and clears the RWU bit. Reset clears the RWU bit.

1 = Standby state

0 = Normal operation

#### SBK — Send Break Bit

Setting and then clearing this read/write bit transmits a break character followed by a logic 1. The logic 1 after the break character guarantees recognition of a valid start bit. If SBK remains set, the transmitter continuously transmits break characters with no logic 1s between them. Reset clears the SBK bit.

1 = Transmit break characters

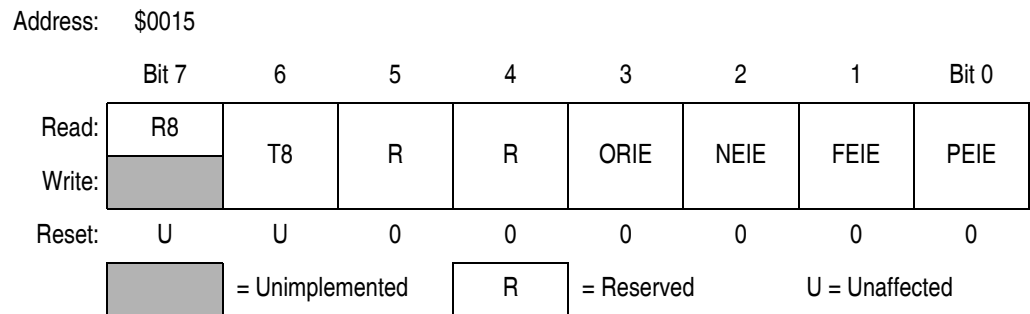
0 = No break characters being transmitted

**NOTE:** *Do not toggle the SBK bit immediately after setting the SCTE bit. Toggling SBK before the preamble begins causes the SCI to send a break character instead of a preamble.*

## 16.9.3 SCI Control Register 3

SCI control register 3:

- Stores the ninth SCI data bit received and the ninth SCI data bit to be transmitted.
- Enables the following interrupts:
  - Receiver overrun interrupts
  - Noise error interrupts
  - Framing error interrupts
  - Parity error interrupts



**Figure 16-10. SCI Control Register 3 (SCC3)**

### R8 — Received Bit 8

When the SCI is receiving 9-bit characters, R8 is the read-only ninth bit (bit 8) of the received character. R8 is received at the same time that the SCDR receives the other 8 bits.

When the SCI is receiving 8-bit characters, R8 is a copy of the eighth bit (bit 7). Reset has no effect on the R8 bit.

### T8 — Transmitted Bit 8

When the SCI is transmitting 9-bit characters, T8 is the read/write ninth bit (bit 8) of the transmitted character. T8 is loaded into the transmit shift register at the same time that the SCDR is loaded into the transmit shift register. Reset has no effect on the T8 bit.

**ORIE — Receiver Overrun Interrupt Enable Bit**

This read/write bit enables SCI error CPU interrupt requests generated by the receiver overrun bit, OR.

- 1 = SCI error CPU interrupt requests from OR bit enabled
- 0 = SCI error CPU interrupt requests from OR bit disabled

**NEIE — Receiver Noise Error Interrupt Enable Bit**

This read/write bit enables SCI error CPU interrupt requests generated by the noise error bit, NE. Reset clears NEIE.

- 1 = SCI error CPU interrupt requests from NE bit enabled
- 0 = SCI error CPU interrupt requests from NE bit disabled

**FEIE — Receiver Framing Error Interrupt Enable Bit**

This read/write bit enables SCI error CPU interrupt requests generated by the framing error bit, FE. Reset clears FEIE.

- 1 = SCI error CPU interrupt requests from FE bit enabled
- 0 = SCI error CPU interrupt requests from FE bit disabled

**PEIE — Receiver Parity Error Interrupt Enable Bit**

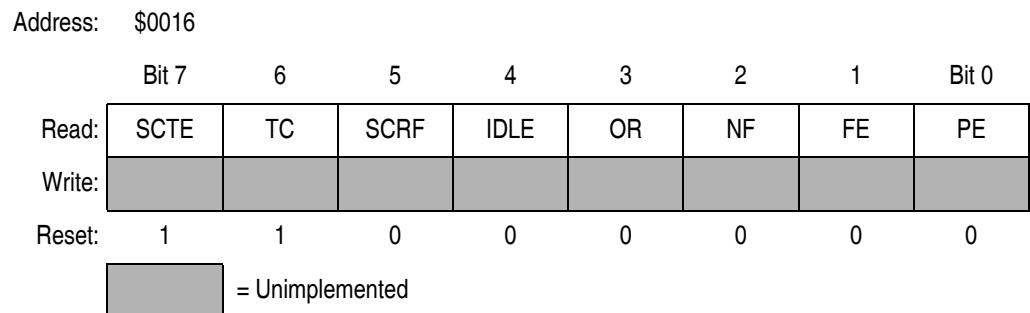
This read/write bit enables SCI receiver CPU interrupt requests generated by the parity error bit, PE. Reset clears PEIE.

- 1 = SCI error CPU interrupt requests from PE bit enabled
- 0 = SCI error CPU interrupt requests from PE bit disabled

## 16.9.4 SCI Status Register 1

SCI status register 1 contains flags to signal the following conditions:

- Transfer of SCDR data to transmit shift register complete
- Transmission complete
- Transfer of receive shift register data to SCDR complete
- Receiver input idle
- Receiver overrun
- Noisy data
- Framing error
- Parity error



**Figure 16-11. SCI Status Register 1 (SCS1)**

### SCTE — SCI Transmitter Empty Bit

This clearable, read-only bit is set when the SCDR transfers a character to the transmit shift register. SCTE can generate an SCI transmitter CPU interrupt request. When the SCTIE bit in SCC2 is set, SCTE generates an SCI transmitter CPU interrupt request. In normal operation, clear the SCTE bit by reading SCS1 with SCTE set and then writing to SCDR. Reset sets the SCTE bit.

- 1 = SCDR data transferred to transmit shift register
- 0 = SCDR data not transferred to transmit shift register

### TC — Transmission Complete Bit

This read-only bit is set when the SCTE bit is set, and no data, preamble, or break character is being transmitted. TC generates an SCI transmitter CPU interrupt request if the TCIE bit in SCC2 is also set. TC is cleared automatically when data, preamble, or break is queued and ready to be sent. There may be up to 1.5 transmitter clocks of latency between queueing data, preamble, and break and the transmission actually starting. Reset sets the TC bit.

1 = No transmission in progress

0 = Transmission in progress

### SCRF — SCI Receiver Full Bit

This clearable, read-only bit is set when the data in the receive shift register transfers to the SCI data register. SCRF can generate an SCI receiver CPU interrupt request. When the SCRIE bit in SCC2 is set the SCRF generates a CPU interrupt request. In normal operation, clear the SCRF bit by reading SCS1 with SCRF set and then reading the SCDR. Reset clears SCRF.

1 = Received data available in SCDR

0 = Data not available in SCDR

### IDLE — Receiver Idle Bit

This clearable, read-only bit is set when 10 or 11 consecutive logic 1s appear on the receiver input. IDLE generates an SCI error CPU interrupt request if the ILIE bit in SCC2 is also set. Clear the IDLE bit by reading SCS1 with IDLE set and then reading the SCDR. After the receiver is enabled, it must receive a valid character that sets the SCRF bit before an idle condition can set the IDLE bit. Also, after the IDLE bit has been cleared, a valid character must again set the SCRF bit before an idle condition can set the IDLE bit. Reset clears the IDLE bit.

1 = Receiver input idle

0 = Receiver input active (or idle since the IDLE bit was cleared)

### OR — Receiver Overrun Bit

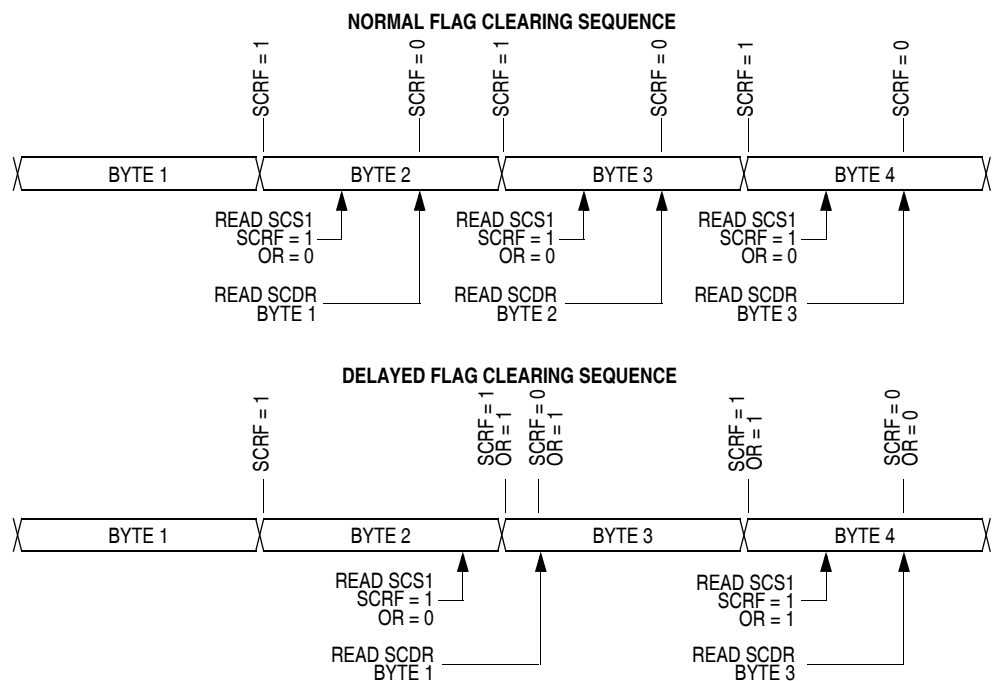
This clearable, read-only bit is set when software fails to read the SCDR before the receive shift register receives the next character. The OR bit generates an SCI error CPU interrupt request if the ORIE

bit in SCC3 is also set. The data in the shift register is lost, but the data already in the SCDR is not affected. Clear the OR bit by reading SCS1 with OR set and then reading the SCDR. Reset clears the OR bit.

- 1 = Receive shift register full and SCRF = 1
- 0 = No receiver overrun

Software latency may allow an overrun to occur between reads of SCS1 and SCDR in the flag-clearing sequence. **Figure 16-12** shows the normal flag-clearing sequence and an example of an overrun caused by a delayed flag-clearing sequence. The delayed read of SCDR does not clear the OR bit because OR was not set when SCS1 was read. Byte 2 caused the overrun and is lost. The next flag-clearing sequence reads byte 3 in the SCDR instead of byte 2.

In applications that are subject to software latency or in which it is important to know which byte is lost due to an overrun, the flag-clearing routine can check the OR bit in a second read of SCS1 after reading the data register.



**Figure 16-12. Flag Clearing Sequence**

#### NF — Receiver Noise Flag Bit

This clearable, read-only bit is set when the SCI detects noise on the RxD pin. NF generates an NF CPU interrupt request if the NEIE bit in SCC3 is also set. Clear the NF bit by reading SCS1 and then reading the SCDR. Reset clears the NF bit.

1 = Noise detected

0 = No noise detected

#### FE — Receiver Framing Error Bit

This clearable, read-only bit is set when a logic 0 is accepted as the stop bit. FE generates an SCI error CPU interrupt request if the FEIE bit in SCC3 also is set. Clear the FE bit by reading SCS1 with FE set and then reading the SCDR. Reset clears the FE bit.

1 = Framing error detected

0 = No framing error detected

#### PE — Receiver Parity Error Bit

This clearable, read-only bit is set when the SCI detects a parity error in incoming data. PE generates a PE CPU interrupt request if the PEIE bit in SCC3 is also set. Clear the PE bit by reading SCS1 with PE set and then reading the SCDR. Reset clears the PE bit.

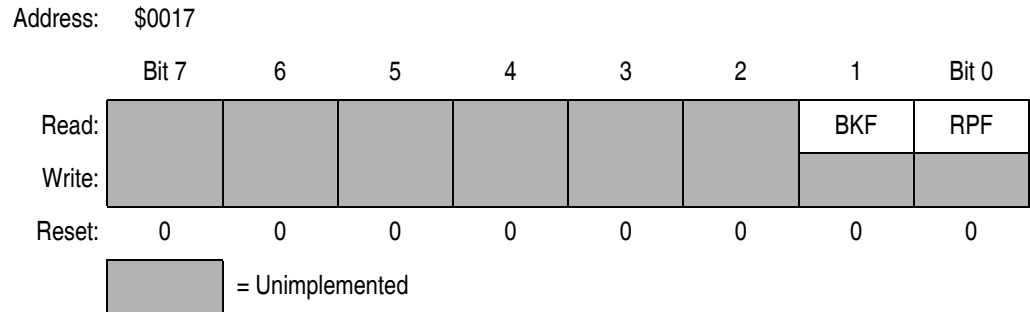
1 = Parity error detected

0 = No parity error detected

## 16.9.5 SCI Status Register 2

SCI status register 2 contains flags to signal the following conditions:

- Break character detected
- Incoming data



**Figure 16-13. SCI Status Register 2 (SCS2)**

### BKF — Break Flag Bit

This clearable, read-only bit is set when the SCI detects a break character on the RxD pin. In SCS1, the FE and SCRF bits are also set. In 9-bit character transmissions, the R8 bit in SCC3 is cleared. BKF does not generate a CPU interrupt request. Clear BKF by reading SCS2 with BKF set and then reading the SCDR. Once cleared, BKF can become set again only after logic 1s again appear on the RxD pin followed by another break character. Reset clears the BKF bit.

- 1 = Break character detected
- 0 = No break character detected

### RPF — Reception in Progress Flag Bit

This read-only bit is set when the receiver detects a logic 0 during the RT1 time period of the start bit search. RPF does not generate an interrupt request. RPF is reset after the receiver detects false start bits (usually from noise or a baud rate mismatch), or when the receiver detects an idle character. Polling RPF before disabling the SCI module or entering stop mode can show whether a reception is in progress.

- 1 = Reception in progress
- 0 = No reception in progress



### 16.9.6 SCI Data Register

The SCI data register is the buffer between the internal data bus and the receive and transmit shift registers. Reset has no effect on data in the SCI data register.

Address: \$0018

	Bit 7	6	5	4	3	2	1	Bit 0
Read:	R7	R6	R5	R4	R3	R2	R1	R0
Write:	T7	T6	T5	T4	T3	T2	T1	T0

Reset: Unaffected by Reset

**Figure 16-14. SCI Data Register (SCDR)**

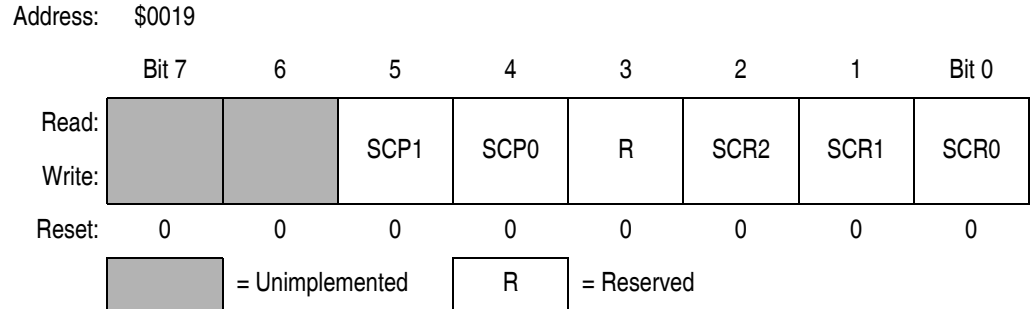
#### R7/T7:R0/T0 — Receive/Transmit Data Bits

Reading address \$0018 accesses the read-only received data bits, R7:R0. Writing to address \$0018 writes the data to be transmitted, T7:T0. Reset has no effect on the SCI data register.

**NOTE:** Do not use read-modify-write instructions on the SCI data register.

## 16.9.7 SCI Baud Rate Register

The baud rate register selects the baud rate for both the receiver and the transmitter.



**Figure 16-15. SCI Baud Rate Register (SCBR)**

### SCP1 and SCP0 — SCI Baud Rate Prescaler Bits

These read/write bits select the baud rate prescaler divisor as shown in [Table 16-12](#). Reset clears SCP1 and SCP0.

**Table 16-12. SCI Baud Rate Prescaling**

SCP[1:0]	Prescaler Divisor (PD)
00	1
01	3
10	4
11	13

**SCR2 – SCR0 — SCI Baud Rate Select Bits**

These read/write bits select the SCI baud rate divisor as shown in [Table 16-13](#). Reset clears SCR2–SCR0.

**Table 16-13. SCI Baud Rate Selection**

SCR[2:1:0]	Baud Rate Divisor (BD)
000	1
001	2
010	4
011	8
100	16
101	32
110	64
111	128

Use the following formula to calculate the SCI baud rate:

$$\text{Baud rate} = \frac{f_{\text{Crystal}}}{64 \times \text{PD} \times \text{BD}}$$

where:

$f_{\text{Crystal}}$  = crystal frequency

PD = prescaler divisor

BD = baud rate divisor

[Table 16-14](#) shows the SCI baud rates that can be generated with a 4.194-MHz crystal.

**Table 16-14. SCI Baud Rate Selection Examples**

SCP[1:0]	Prescaler Divisor (PD)	SCR[2:1:0]	Baud Rate Divisor (BD)	Baud Rate (f <sub>Crystal</sub> = 4.9152 MHz)
00	1	000	1	76,800
00	1	001	2	38,400
00	1	010	4	19,200
00	1	011	8	9600
00	1	100	16	4800
00	1	101	32	2400
00	1	110	64	1200
00	1	111	128	600
01	3	000	1	25,600
01	3	001	2	12,800
01	3	010	4	6400
01	3	011	8	3200
01	3	100	16	1600
01	3	101	32	800
01	3	110	64	400
01	3	111	128	200
10	4	000	1	19,200
10	4	001	2	9600
10	4	010	4	4800
10	4	011	8	2400
10	4	100	16	1200
10	4	101	32	600
10	4	110	64	300
10	4	111	128	150
11	13	000	1	5908
11	13	001	2	2954
11	13	010	4	1477
11	13	011	8	739
11	13	100	16	369
11	13	101	32	185
11	13	110	64	92
11	13	111	128	46

## Section 17. Serial Peripheral Interface (SPI)

### 17.1 Contents

17.2	Introduction . . . . .	254
17.3	Features . . . . .	254
17.4	Pin Name and Register Name Conventions . . . . .	255
17.5	Functional Description . . . . .	256
17.5.1	Master Mode . . . . .	258
17.5.2	Slave Mode . . . . .	259
17.6	Transmission Formats . . . . .	260
17.6.1	Clock Phase and Polarity Controls . . . . .	260
17.6.2	Transmission Format When CPHA = 0 . . . . .	261
17.6.3	Transmission Format When CPHA = 1 . . . . .	262
17.6.4	Transmission Initiation Latency . . . . .	263
17.7	Error Conditions . . . . .	265
17.7.1	Overflow Error . . . . .	265
17.7.2	Mode Fault Error . . . . .	267
17.8	Interrupts . . . . .	269
17.9	Queuing Transmission Data . . . . .	270
17.10	Resetting the SPI . . . . .	272
17.11	Low-Power Modes . . . . .	273
17.11.1	Wait Mode . . . . .	273
17.11.2	Stop Mode . . . . .	273
17.12	SPI During Break Interrupts . . . . .	274
17.13	I/O Signals . . . . .	275
17.13.1	MISO (Master In/Slave Out) . . . . .	275
17.13.2	MOSI (Master Out/Slave In) . . . . .	276

17.13.3	SPSCK (Serial Clock) .....	276
17.13.4	SS (Slave Select) .....	277
17.13.5	VSS (Clock Ground) .....	278
17.14	I/O Registers .....	278
17.14.1	SPI Control Register .....	279
17.14.2	SPI Status and Control Register .....	281
17.14.3	SPI Data Register .....	285

## 17.2 Introduction

This section describes the serial peripheral interface (SPI) module, which allows full-duplex, synchronous, serial communications with peripheral devices.

## 17.3 Features

Features of the SPI module include:

- Full-Duplex Operation
- Master and Slave Modes
- Double-Buffered Operation with Separate Transmit and Receive Registers
- Four Master Mode Frequencies (Maximum = Bus Frequency  $\div$  2)
- Maximum Slave Mode Frequency = Bus Frequency
- Serial Clock with Programmable Polarity and Phase
- Two Separately Enabled Interrupts with CPU Service:
  - SPRF (SPI Receiver Full)
  - SPTE (SPI Transmitter Empty)
- Mode Fault Error Flag with CPU Interrupt Capability
- Overflow Error Flag with CPU Interrupt Capability
- Programmable Wired-OR Mode
- I<sup>2</sup>C (Inter-Integrated Circuit) Compatibility

## 17.4 Pin Name and Register Name Conventions

The generic names of the SPI input/output (I/O) pins are:

- $\overline{SS}$  (slave select)
- SPSCCK (SPI serial clock)
- MOSI (master out slave in)
- MISO (master in slave out)

The SPI shares four I/O pins with a parallel I/O port. The full name of an SPI pin reflects the name of the shared port pin. [Table 17-1](#) shows the full names of the SPI I/O pins. The generic pin names appear in the text that follows.

**Table 17-1. Pin Name Conventions**

<b>SPI Generic Pin Name</b>	<b>MISO</b>	<b>MOSI</b>	<b><math>\overline{SS}</math></b>	<b>SPSCCK</b>
<b>Full SPI Pin Name</b>	PTE5/MISO	PTE6/MOSI	PTE4/ $\overline{SS}$	PTE7/SPSCCK

The generic names of the SPI I/O registers are:

- SPI control register (SPCR)
- SPI status and control register (SPSCR)
- SPI data register (SPDR)

[Table 17-2](#) shows the names and the addresses of the SPI I/O registers.

**Table 17-2. I/O Register Addresses**

<b>Register Name</b>	<b>Address</b>
SPI Control Register (SPCR)	\$0010
SPI Status and Control Register (SPSCR)	\$0011
SPI Data Register (SPDR)	\$0012

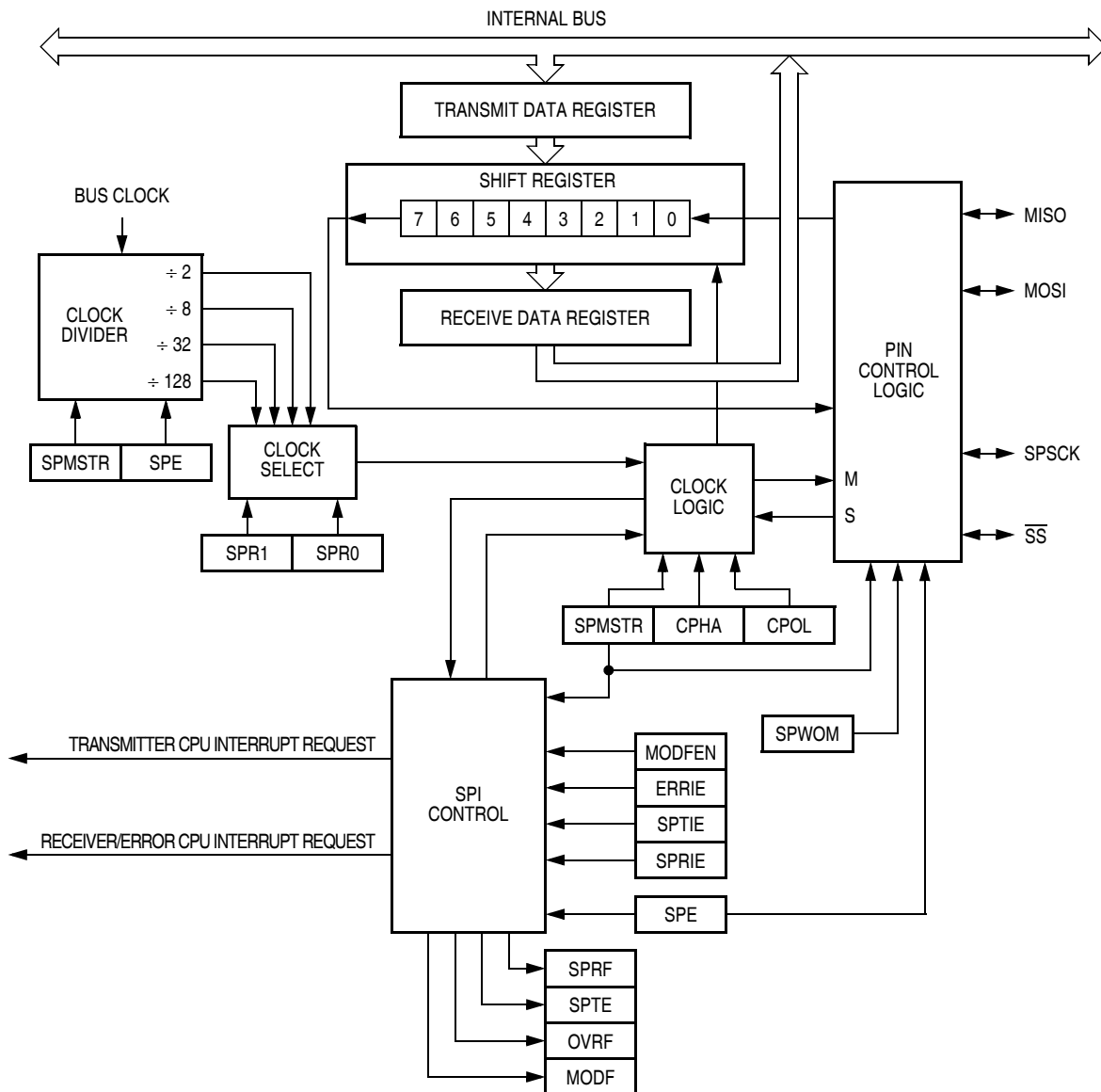
## 17.5 Functional Description

**Table 17-3** summarizes the SPI I/O registers and **Figure 17-1** shows the structure of the SPI module.

**Table 17-3. SPI I/O Register Summary**

Addr.	Register Name		Bit 7	6	5	4	3	2	1	Bit 0
\$0010	SPI Control Register (SPCR)	Read:	SPRIE	R	SPMSTR	CPOL	CPHA	SPWOM	SPE	SPTIE
		Write:								
		Reset:	0	0	1	0	1	0	0	0
\$0011	SPI Status and Control Register (SPSCR)	Read:	SPRF	ERRIE	OVRF	MODF	SPTIE	MODFEN	SPR1	SPR0
		Write:	R		R	R	R			
		Reset:	0	0	0	0	1	0	0	0
\$0012	SPI Data Register (SPDR)	Read:	R7	R6	R5	R4	R3	R2	R1	R0
		Write:	T7	T6	T5	T4	T3	T2	T1	T0
		Reset:	Unaffected by Reset							
			R	= Reserved						





**Figure 17-1. SPI Module Block Diagram**

The SPI module allows full-duplex, synchronous, serial communication between the MCU and peripheral devices, including other MCUs. Software can poll the SPI status flags or SPI operation can be interrupt driven. All SPI interrupts can be serviced by the CPU.

The following paragraphs describe the operation of the SPI module.

# Serial Peripheral Interface (SPI)

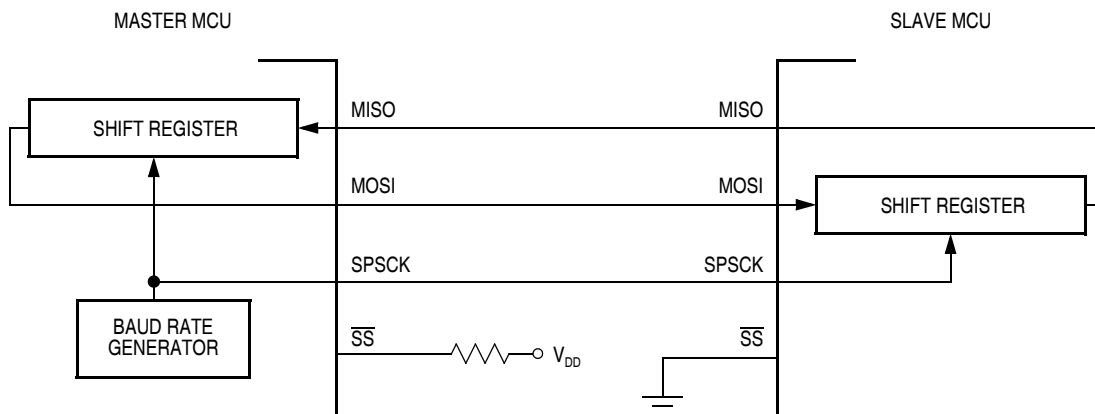
## 17.5.1 Master Mode

The SPI operates in master mode when the SPI master bit, SPMSTR (SPCR \$0010), is set.

**NOTE:** *Configure the SPI modules as master and slave before enabling them. Enable the master SPI before enabling the slave SPI. Disable the slave SPI before disabling the master SPI. (See [17.14.1 SPI Control Register](#).)*

Only a master SPI module can initiate transmissions. Software begins the transmission from a master SPI module by writing to the SPI data register. If the shift register is empty, the byte immediately transfers to the shift register, setting the SPI transmitter empty bit, SPTE (SPSCR \$0011). The byte begins shifting out on the MOSI pin under the control of the serial clock. (See [Figure 17-2](#).)

The SPR1 and SPR0 bits control the baud rate generator and determine the speed of the shift register. (See [17.14.2 SPI Status and Control Register](#).) Through the SPSCCK pin, the baud rate generator of the master also controls the shift register of the slave peripheral.



**Figure 17-2. Full-Duplex Master-Slave Connections**

As the byte shifts out on the MOSI pin of the master, another byte shifts in from the slave on the master's MISO pin. The transmission ends when the receiver full bit, SPRF (SPSCR), becomes set. At the same time that SPRF becomes set, the byte from the slave transfers to the receive data register. In normal operation, SPRF signals the end of a transmission. Software clears SPRF by reading the SPI status and control register and then reading the SPI data register. Writing to the SPI data register clears the SPTIE bit.

### 17.5.2 Slave Mode

The SPI operates in slave mode when the SPMSTR bit (SPCR, \$0010) is clear. In slave mode the SPSCCK pin is the input for the serial clock from the master MCU. Before a data transmission occurs, the  $\overline{SS}$  pin of the slave MCU must be at logic 0.  $\overline{SS}$  must remain low until the transmission is complete. (See [17.7.2 Mode Fault Error](#).)

In a slave SPI module, data enters the shift register under the control of the serial clock from the master SPI module. After a byte enters the shift register of a slave SPI, it is transferred to the receive data register, and the SPRF bit (SPSCR) is set. To prevent an overflow condition, slave software then must read the SPI data register before another byte enters the shift register.

The maximum frequency of the SPSCCK for an SPI configured as a slave is the bus clock speed, which is twice as fast as the fastest master SPSCCK clock that can be generated. The frequency of the SPSCCK for an SPI configured as a slave does not have to correspond to any SPI baud rate. The baud rate only controls the speed of the SPSCCK generated by an SPI configured as a master. Therefore, the frequency of the SPSCCK for an SPI configured as a slave can be any frequency less than or equal to the bus speed.

When the master SPI starts a transmission, the data in the slave shift register begins shifting out on the MISO pin. The slave can load its shift register with a new byte for the next transmission by writing to its transmit data register. The slave must write to its transmit data register at least one bus cycle before the master starts the next transmission. Otherwise the byte already in the slave shift register shifts out on the MISO pin.

Data written to the slave shift register during a transmission remains in a buffer until the end of the transmission.

When the clock phase bit (CPHA) is set, the first edge of SPSCCK starts a transmission. When CPHA is clear, the falling edge of  $\overline{SS}$  starts a transmission. (See [17.6 Transmission Formats](#).)

If the write to the data register is late, the SPI transmits the data already in the shift register from the previous transmission.

**NOTE:** *To prevent SPSCCK from appearing as a clock edge, SPSCCK must be in the proper idle state before the slave is enabled.*

## 17.6 Transmission Formats

During an SPI transmission, data is simultaneously transmitted (shifted out serially) and received (shifted in serially). A serial clock line synchronizes shifting and sampling on the two serial data lines. A slave select line allows individual selection of a slave SPI device; slave devices that are not selected do not interfere with SPI bus activities. On a master SPI device, the slave select line can be used optionally to indicate a multiple-master bus contention.

### 17.6.1 Clock Phase and Polarity Controls

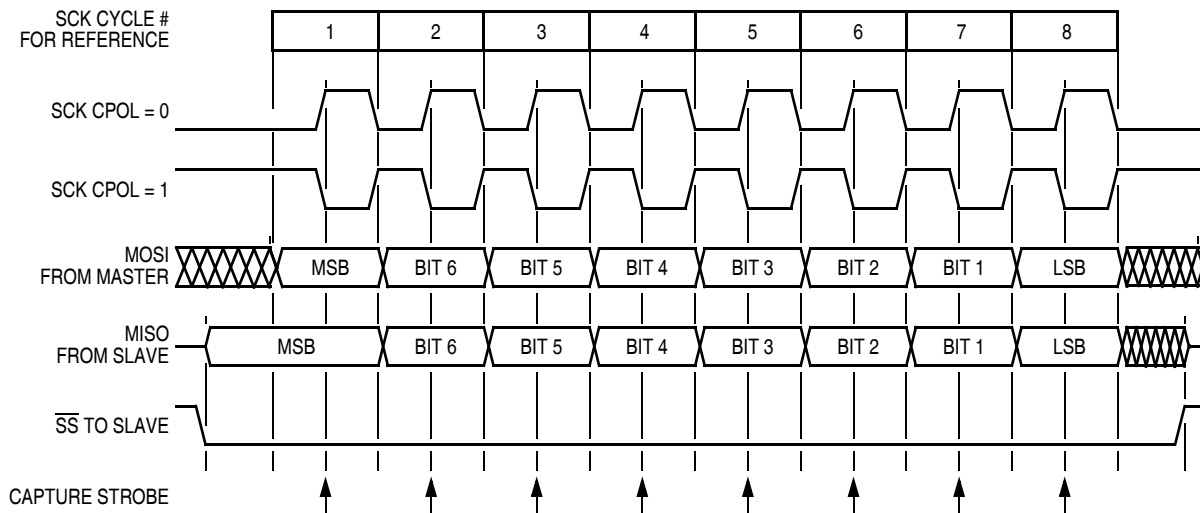
Software can select any of four combinations of serial clock (SCK) phase and polarity using two bits in the SPI control register (SPCR). The clock polarity is specified by the CPOL control bit, which selects an active high or low clock and has no significant effect on the transmission format.

The clock phase (CPHA) control bit (SPCR) selects one of two fundamentally different transmission formats. The clock phase and polarity should be identical for the master SPI device and the communicating slave device. In some cases, the phase and polarity are changed between transmissions to allow a master device to communicate with peripheral slaves having different requirements.

**NOTE:** *Before writing to the CPOL bit or the CPHA bit (SPCR), disable the SPI by clearing the SPI enable bit (SPE).*

## 17.6.2 Transmission Format When CPHA = 0

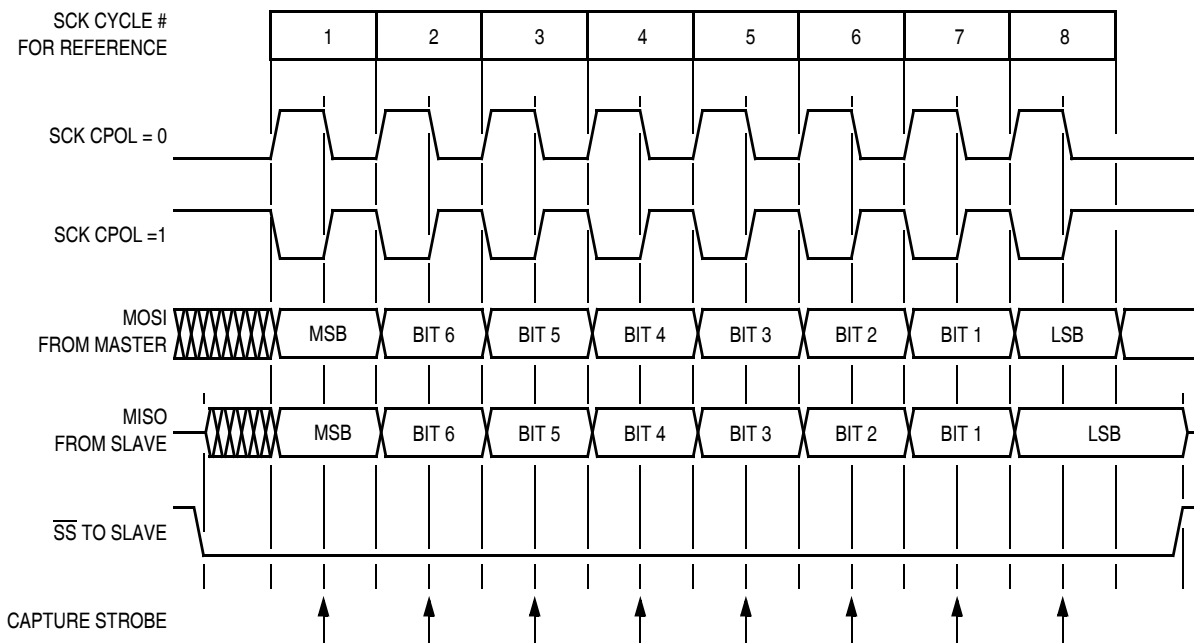
**Figure 17-3** shows an SPI transmission in which CPHA (SPCR) is logic 0. The figure should not be used as a replacement for data sheet parametric information. Two waveforms are shown for SCK: one for CPOL = 0 and another for CPOL = 1. The diagram may be interpreted as a master or slave timing diagram since the serial clock (SCK), master in/slave out (MISO), and master out/slave in (MOSI) pins are directly connected between the master and the slave. The MISO signal is the output from the slave, and the MOSI signal is the output from the master. The  $\overline{SS}$  line is the slave select input to the slave. The slave SPI drives its MISO output only when its slave select input ( $\overline{SS}$ ) is at logic 0, so that only the selected slave drives to the master. The  $\overline{SS}$  pin of the master is not shown but is assumed to be inactive. The  $\overline{SS}$  pin of the master must be high or must be reconfigured as general-purpose I/O not affecting the SPI. (See **17.7.2 Mode Fault Error**.) When CPHA = 0, the first SPSCCK edge is the MSB capture strobe. Therefore, the slave must begin driving its data before the first SPSCCK edge, and a falling edge on the  $\overline{SS}$  pin is used to start the transmission. The  $\overline{SS}$  pin must be toggled high and then low again between each byte transmitted.



**Figure 17-3. Transmission Format (CPHA = 0)**

## 17.6.3 Transmission Format When CPHA = 1

**Figure 17-4** shows an SPI transmission in which CPHA (SPCR) is logic 1. The figure should not be used as a replacement for data sheet parametric information. Two waveforms are shown for SCK: one for CPOL = 0 and another for CPOL = 1. The diagram may be interpreted as a master or slave timing diagram since the serial clock (SCK), master in/slave out (MISO), and master out/slave in (MOSI) pins are directly connected between the master and the slave. The MISO signal is the output from the slave, and the MOSI signal is the output from the master. The  $\overline{SS}$  line is the slave select input to the slave. The slave SPI drives its MISO output only when its slave select input ( $\overline{SS}$ ) is at logic 0, so that only the selected slave drives to the master. The  $\overline{SS}$  pin of the master is not shown but is assumed to be inactive. The  $\overline{SS}$  pin of the master must be high or must be reconfigured as general-purpose I/O not affecting the SPI. (See **17.7.2 Mode Fault Error**.) When CPHA = 1, the master begins driving its MOSI pin on the first SPSCK edge. Therefore, the slave uses the first SPSCK edge as a start transmission signal. The  $\overline{SS}$  pin can remain low between transmissions. This format may be preferable in systems having only one master and only one slave driving the MISO data line.

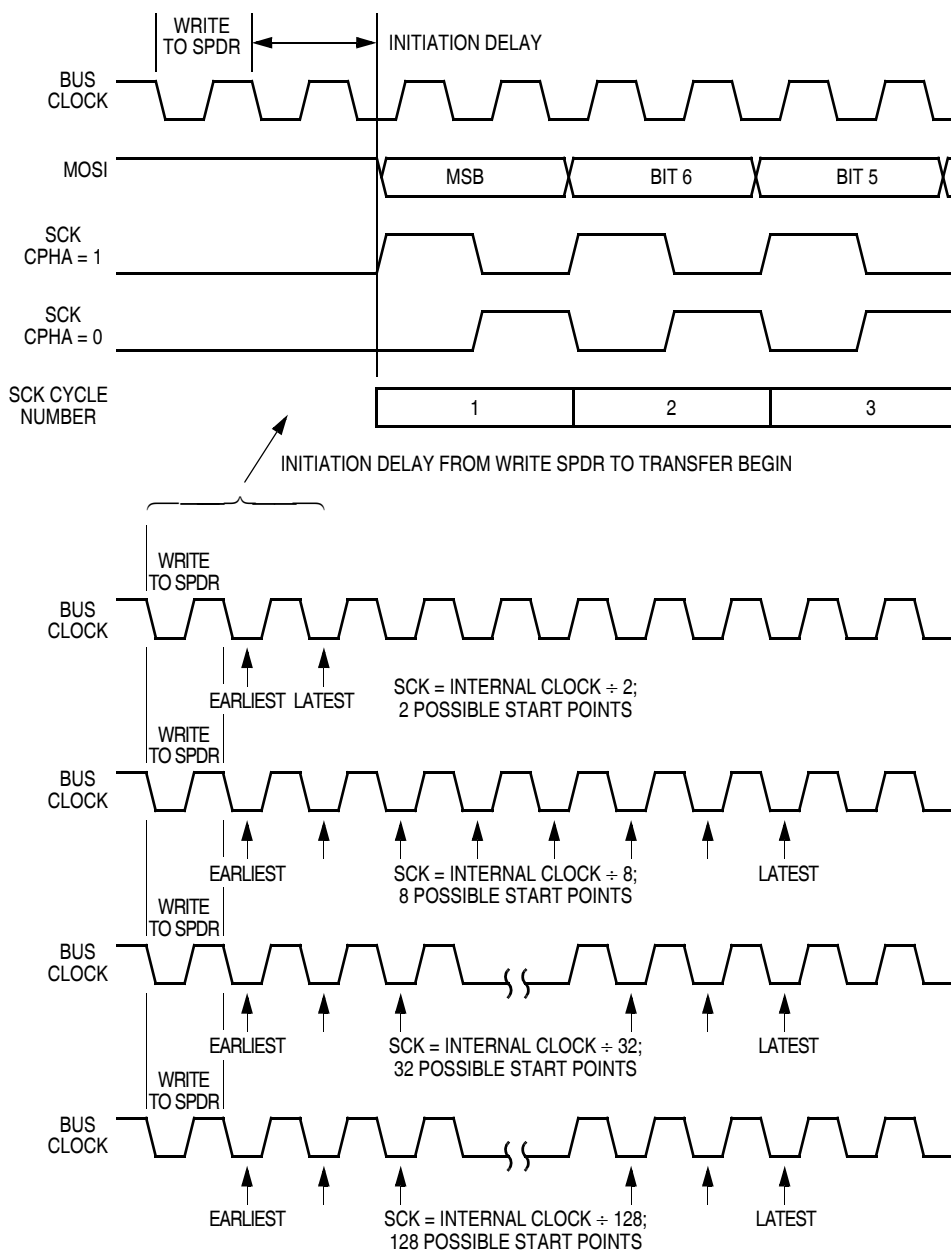


**Figure 17-4. Transmission Format (CPHA = 1)**

### 17.6.4 Transmission Initiation Latency

When the SPI is configured as a master ( $SPMSTR = 1$ ), transmissions are started by a software write to the SPDR (0012). CPHA has no effect on the delay to the start of the transmission, but it does affect the initial state of the SCK signal. When  $CPHA = 0$ , the SCK signal remains inactive for the first half of the first SCK cycle. When  $CPHA = 1$ , the first SCK cycle begins with an edge on the SCK line from its inactive to its active level. The SPI clock rate (selected by  $SPR1$ – $SPR0$ ) affects the delay from the write to SPDR and the start of the SPI transmission. (See [Figure 17-5](#).) The internal SPI clock in the master is a free-running derivative of the internal MCU clock. It is only enabled when both the SPE and SPMSTR bits (SPCR) are set to conserve power. SCK edges occur half way through the low time of the internal MCU clock. Since the SPI clock is free-running, it is uncertain where the write to the SPDR will occur relative to the slower SCK. This uncertainty causes the variation in the initiation delay shown in [Figure 17-5](#). This delay will be no longer than a single SPI bit time. That is, the maximum delay between the write to SPDR and the start of the SPI transmission is two MCU bus cycles for DIV2, eight MCU bus cycles for DIV8, 32 MCU bus cycles for DIV32, and 128 MCU bus cycles for DIV128.

# Serial Peripheral Interface (SPI)



**Figure 17-5. Transmission Start Delay (Master)**



## 17.7 Error Conditions

Two flags signal SPI error conditions:

1. Overflow (OVRFin SPSCR) — Failing to read the SPI data register before the next byte enters the shift register sets the OVRF bit. The new byte does not transfer to the receive data register, and the unread byte still can be read by accessing the SPI data register. OVRF is in the SPI status and control register.
2. Mode fault error (MODF in SPSCR) — The MODF bit indicates that the voltage on the slave select pin ( $\overline{SS}$ ) is inconsistent with the mode of the SPI. MODF is in the SPI status and control register.

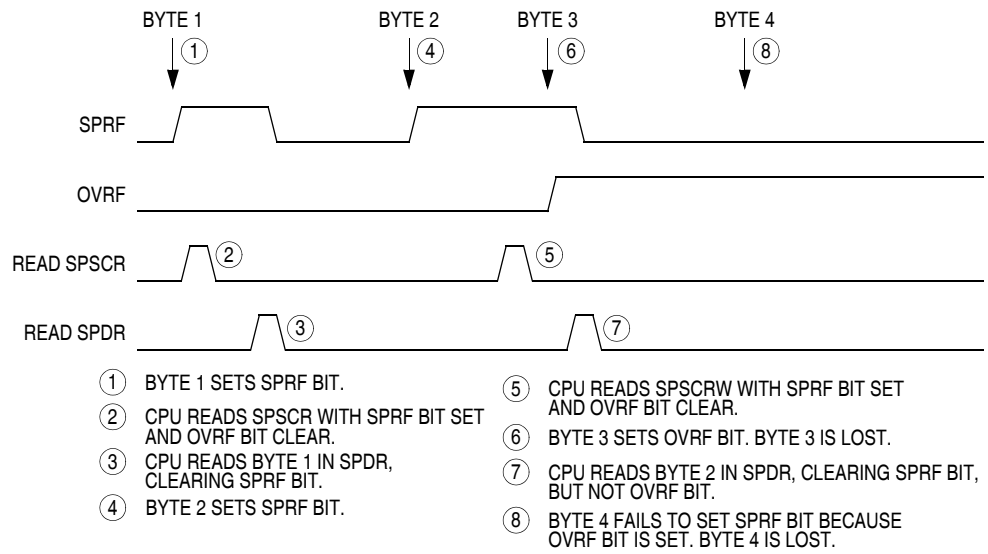
### 17.7.1 Overflow Error

The overflow flag (OVRF in SPSCR) becomes set if the SPI receive data register still has unread data from a previous transmission when the capture strobe of bit 1 of the next transmission occurs. (See [Figure 17-3](#) and [Figure 17-4](#).) If an overflow occurs, the data being received is not transferred to the receive data register so that the unread data can still be read. Therefore, an overflow error always indicates the loss of data.

OVRF generates a receiver/error CPU interrupt request if the error interrupt enable bit (ERRIE in SPSCR) is also set. MODF and OVRF can generate a receiver/error CPU interrupt request. (See [Figure 17-8](#).) It is not possible to enable only MODF or OVRF to generate a receiver/error CPU interrupt request. However, leaving MODFEN low prevents MODF from being set.

If an end-of-block transmission interrupt was meant to pull the MCU out of wait, having an overflow condition without overflow interrupts enabled causes the MCU to hang in wait mode. If the OVRF is enabled to generate an interrupt, it can pull the MCU out of wait mode instead.

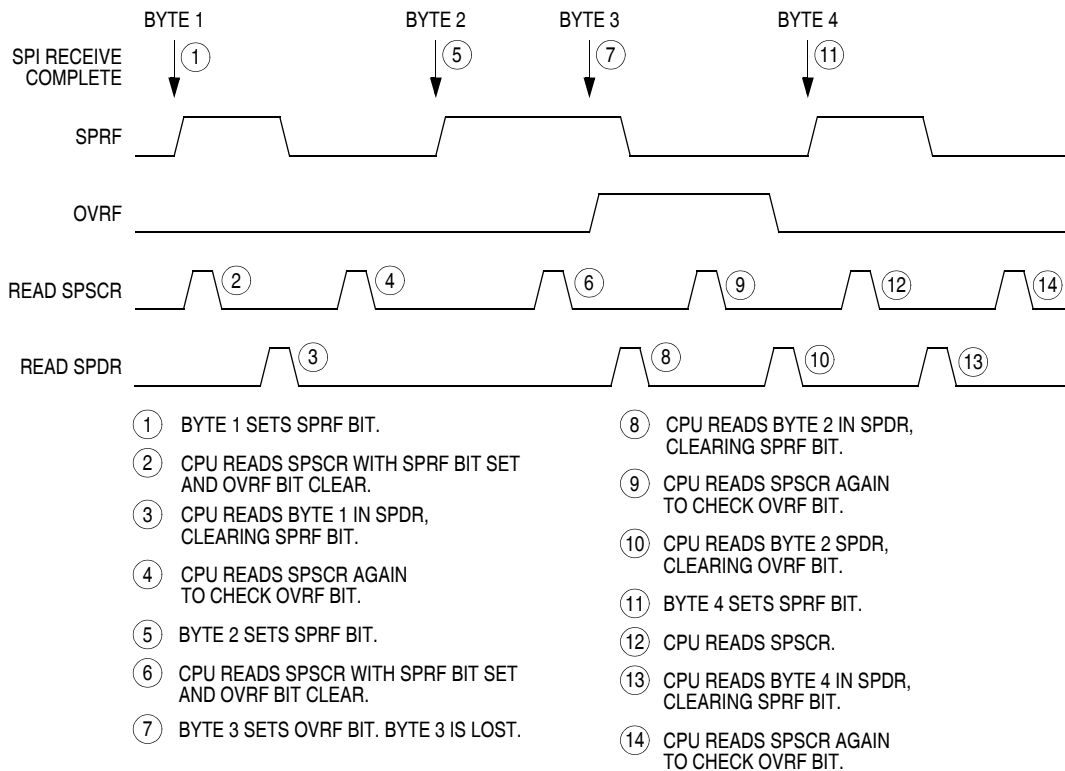
If the CPU SPRF interrupt is enabled and the OVRF interrupt is not, watch for an overflow condition. [Figure 17-6](#) shows how it is possible to miss an overflow.



**Figure 17-6. Missed Read of Overflow Condition**

The first part of [Figure 17-6](#) shows how to read the SPSCR and SPDR to clear the SPRF without problems. However, as illustrated by the second transmission example, the OVRF flag can be set in between the time that SPSCR and SPDR are read.

In this case, an overflow can be easily missed. Since no more SPRF interrupts can be generated until this OVRF is serviced, it will not be obvious that bytes are being lost as more transmissions are completed. To prevent this, either enable the OVRF interrupt or do another read of the SPSCR after the read of the SPDR. This ensures that the OVRF was not set before the SPRF was cleared and that future transmissions will complete with an SPRF interrupt. [Figure 17-7](#) illustrates this process. Generally, to avoid this second SPSCR read, enable the OVRF to the CPU by setting the ERRIE bit (SPSCR).



**Figure 17-7. Clearing SPRF When OVRF Interrupt Is Not Enabled**

### 17.7.2 Mode Fault Error

For the MODF flag (in SPSCR) to be set, the mode fault error enable bit (MODFEN in SPSCR) must be set. Clearing the MODFEN bit does not clear the MODF flag but does prevent MODF from being set again after MODF is cleared.

MODF generates a receiver/error CPU interrupt request if the error interrupt enable bit (ERRIE in SPSCR) is also set. The SPRF, MODF, and OVRF interrupts share the same CPU interrupt vector. MODF and OVRF can generate a receiver/error CPU interrupt request. (See [Figure 17-8](#).) It is not possible to enable only MODF or OVRF to generate a receiver/error CPU interrupt request. However, leaving MODFEN low prevents MODF from being set.

In a master SPI with the mode fault enable bit (MODFEN) set, the mode fault flag (MODF) is set if  $\overline{SS}$  goes to logic 0. A mode fault in a master SPI causes the following events to occur:

- If ERRIE = 1, the SPI generates an SPI receiver/error CPU interrupt request.
- The SPE bit is cleared.
- The SPTE bit is set.
- The SPI state counter is cleared.
- The data direction register of the shared I/O port regains control of port drivers.

**NOTE:** *To prevent bus contention with another master SPI after a mode fault error, clear all data direction register (DDR) bits associated with the SPI shared port pins.*

**NOTE:** *Setting the MODF flag (SPSCR) does not clear the SPMSTR bit. Reading SPMSTR when MODF = 1 will indicate a MODE fault error occurred in either master mode or slave mode.*

When configured as a slave (SPMSTR = 0), the MODF flag is set if  $\overline{SS}$  goes high during a transmission. When CPHA = 0, a transmission begins when  $\overline{SS}$  goes low and ends once the incoming SPSCCK returns to its idle level after the shift of the eighth data bit. When CPHA = 1, the transmission begins when the SPSCCK leaves its idle level and  $\overline{SS}$  is already low. The transmission continues until the SPSCCK returns to its IDLE level after the shift of the last data bit. (See [17.6 Transmission Formats](#).)

**NOTE:** *When CPHA = 0, a MODF occurs if a slave is selected ( $\overline{SS}$  is at logic 0) and later unselected ( $\overline{SS}$  is at logic 1) even if no SPSCCK is sent to that slave. This happens because  $\overline{SS}$  at logic 0 indicates the start of the transmission (MISO driven out with the value of MSB) for CPHA = 0. When CPHA = 1, a slave can be selected and then later unselected with no transmission occurring. Therefore, MODF does not occur since a transmission was never begun.*

In a slave SPI (MSTR = 0), the MODF bit generates an SPI receiver/error CPU interrupt request if the ERRIE bit is set. The MODF

bit does not clear the SPE bit or reset the SPI in any way. Software can abort the SPI transmission by toggling the SPE bit of the slave.

**NOTE:** *A logic 1 voltage on the  $\overline{SS}$  pin of a slave SPI puts the MISO pin in a high impedance state. Also, the slave SPI ignores all incoming SPSCCK clocks, even if a transmission has begun.*

To clear the MODF flag, read the SPSCR and then write to the SPCR register. This entire clearing procedure must occur with no MODF condition existing or else the flag will not be cleared.

## 17.8 Interrupts

Four SPI status flags can be enabled to generate CPU interrupt requests:

**Table 17-4. SPI Interrupts**

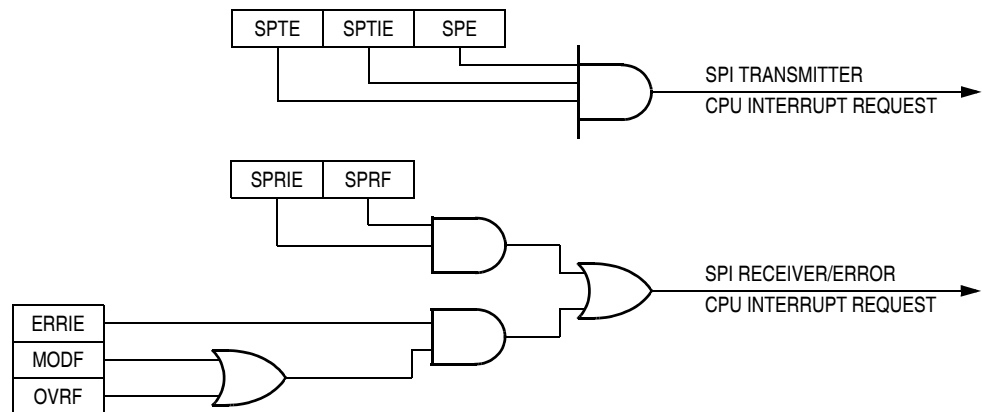
Flag	Request
SPTIE (Transmitter Empty)	SPI Transmitter CPU Interrupt Request (SPTIE = 1)
SPRF (Receiver Full)	SPI Receiver CPU Interrupt Request (SPRIE = 1)
OVRF (Overflow)	SPI Receiver/Error Interrupt Request (SPRIE = 1, ERRIE = 1)
MODF (Mode Fault)	SPI Receiver/Error Interrupt Request (SPRIE = 1, ERRIE = 1, MODFEN = 1)

The SPI transmitter interrupt enable bit (SPTIE) enables the SPTIE flag to generate transmitter CPU interrupt requests.

The SPI receiver interrupt enable bit (SPRIE) enables the SPRF bit to generate receiver CPU interrupt, provided that the SPI is enabled (SPE = 1).

The error interrupt enable bit (ERRIE) enables both the MODF and OVRF flags to generate a receiver/error CPU interrupt request.

The mode fault enable bit (MODFEN) can prevent the MODF flag from being set so that only the OVRF flag is enabled to generate receiver/error CPU interrupt requests.



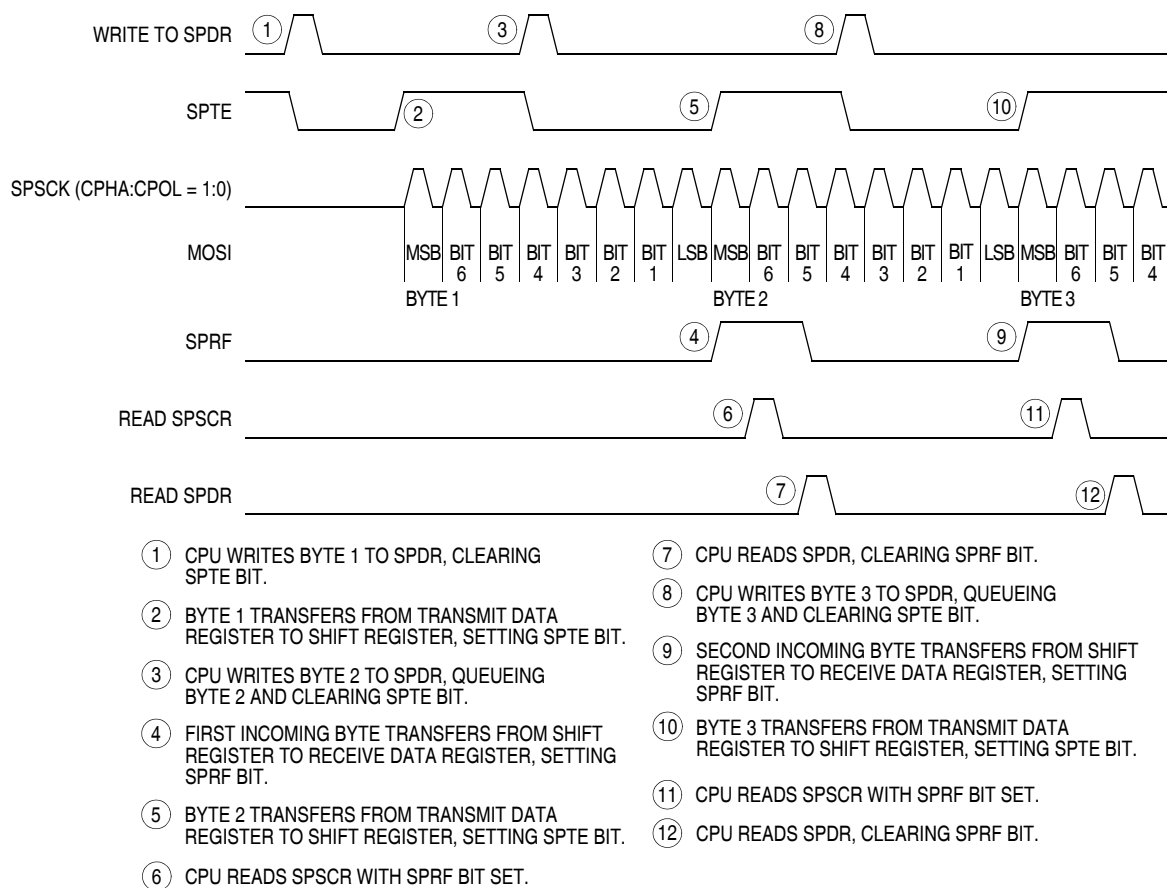
**Figure 17-8. SPI Interrupt Request Generation**

Two sources in the SPI status and control register can generate CPU interrupt requests:

1. SPI receiver full bit (SPRF) — The SPRF bit becomes set every time a byte transfers from the shift register to the receive data register. If the SPI receiver interrupt enable bit, SPRIE, is also set, SPRF can generate an SPI receiver/error CPU interrupt request.
2. SPI transmitter empty (SPTE) — The SPTE bit becomes set every time a byte transfers from the transmit data register to the shift register. If the SPI transmit interrupt enable bit, SPTIE, is also set, SPTE can generate an SPTE CPU interrupt request.

## 17.9 Queuing Transmission Data

The double-buffered transmit data register allows a data byte to be queued and transmitted. For an SPI configured as a master, a queued data byte is transmitted immediately after the previous transmission has completed. The SPI transmitter empty flag (SPTE in SPSCR) indicates when the transmit data buffer is ready to accept new data. Write to the SPI data register only when the SPTE bit is high. [Figure 17-9](#) shows the timing associated with doing back-to-back transmissions with the SPI (SPSCK has CPHA:CPOL = 1:0).



**Figure 17-9. SPRF/SPTe CPU Interrupt Timing**

For a slave, the transmit data buffer allows back-to-back transmissions to occur without the slave having to time the write of its data between the transmissions. Also, if no new data is written to the data buffer, the last value contained in the shift register will be the next data word transmitted.

## 17.10 Resetting the SPI

Any system reset completely resets the SPI. Partial resets occur whenever the SPI enable bit (SPE) is low. Whenever SPE is low, the following occurs:

- The SPTE flag is set.
- Any transmission currently in progress is aborted.
- The shift register is cleared.
- The SPI state counter is cleared, making it ready for a new complete transmission.
- All the SPI port logic is defaulted back to being general-purpose I/O.

The following additional items are reset only by a system reset:

- All control bits in the SPCR register
- All control bits in the SPSCR register (MODFEN, ERRIE, SPR1, and SPR0)
- The status flags SPRF, OVRF, and MODF

By not resetting the control bits when SPE is low, the user can clear SPE between transmissions without having to reset all control bits when SPE is set back to high for the next transmission.

By not resetting the SPRF, OVRF, and MODF flags, the user can still service these interrupts after the SPI has been disabled. The user can disable the SPI by writing 0 to the SPE bit. The SPI also can be disabled by a mode fault occurring in an SPI that was configured as a master with the MODFEN bit set.



## 17.11 Low-Power Modes

The WAIT and STOP instructions put the MCU in low-power standby modes.

### 17.11.1 Wait Mode

The SPI module remains active after the execution of a WAIT instruction. In wait mode, the SPI module registers are not accessible by the CPU. Any enabled CPU interrupt request from the SPI module can bring the MCU out of wait mode.

If SPI module functions are not required during wait mode, reduce power consumption by disabling the SPI module before executing the WAIT instruction.

To exit wait mode when an overflow condition occurs, enable the OVRF bit to generate CPU interrupt requests by setting the error interrupt enable bit (ERRIE). (See [17.8 Interrupts](#).)

### 17.11.2 Stop Mode

The SPI module is inactive after the execution of a STOP instruction. The STOP instruction does not affect register conditions. SPI operation resumes after the MCU exits stop mode. If stop mode is exited by reset, any transfer in progress is aborted and the SPI is reset.

## 17.12 SPI During Break Interrupts

The system integration module (SIM) controls whether status bits in other modules can be cleared during the break state. The BCFE bit in the SIM break flag control register (SBFCR, \$FE03) enables software to clear status bits during the break state. (See [7.8.3 SIM Break Flag Control Register](#).)

To allow software to clear status bits during a break interrupt, write a logic 1 to the BCFE bit. If a status bit is cleared during the break state, it remains cleared when the MCU exits the break state.

To protect status bits during the break state, write a logic 0 to the BCFE bit. With BCFE at logic 0 (its default state), software can read and write I/O registers during the break state without affecting status bits. Some status bits have a two-step read/write clearing procedure. If software does the first step on such a bit before the break, the bit cannot change during the break state as long as BCFE is at logic 0. After the break, doing the second step clears the status bit.

Since the SPTE bit cannot be cleared during a break with the BCFE bit cleared, a write to the data register in break mode will not initiate a transmission nor will this data be transferred into the shift register. Therefore, a write to the SPDR in break mode with the BCFE bit cleared has no effect.

## 17.13 I/O Signals

The SPI module has four I/O pins and shares three of them with a parallel I/O port.

- MISO — Data received
- MOSI — Data transmitted
- SPSCK — Serial clock
- $\overline{SS}$  — Slave select
- $V_{SS}$  — Clock ground

The SPI has limited inter-integrated circuit (I<sup>2</sup>C) capability (requiring software support) as a master in a single-master environment. To communicate with I<sup>2</sup>C peripherals, MOSI becomes an open-drain output when the SPWOM bit in the SPI control register is set. In I<sup>2</sup>C communication, the MOSI and MISO pins are connected to a bidirectional pin from the I<sup>2</sup>C peripheral and through a pullup resistor to  $V_{DD}$ .

### 17.13.1 MISO (Master In/Slave Out)

MISO is one of the two SPI module pins that transmit serial data. In full duplex operation, the MISO pin of the master SPI module is connected to the MISO pin of the slave SPI module. The master SPI simultaneously receives data on its MISO pin and transmits data from its MOSI pin.

Slave output data on the MISO pin is enabled only when the SPI is configured as a slave. The SPI is configured as a slave when its SPMSTR bit is logic 0 and its  $\overline{SS}$  pin is at logic 0. To support a multiple-slave system, a logic 1 on the  $\overline{SS}$  pin puts the MISO pin in a high-impedance state.

When enabled, the SPI controls data direction of the MISO pin regardless of the state of the data direction register of the shared I/O port.

### 17.13.2 MOSI (Master Out/Slave In)

MOSI is one of the two SPI module pins that transmit serial data. In full duplex operation, the MOSI pin of the master SPI module is connected to the MOSI pin of the slave SPI module. The master SPI simultaneously transmits data from its MOSI pin and receives data on its MISO pin.

When enabled, the SPI controls data direction of the MOSI pin regardless of the state of the data direction register of the shared I/O port.

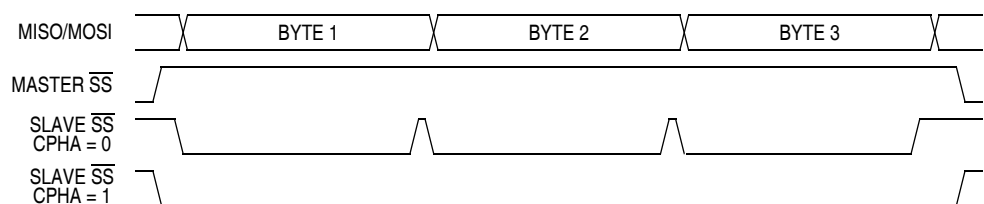
### 17.13.3 SPSCCK (Serial Clock)

The serial clock synchronizes data transmission between master and slave devices. In a master MCU, the SPSCCK pin is the clock output. In a slave MCU, the SPSCCK pin is the clock input. In full duplex operation, the master and slave MCUs exchange a byte of data in eight serial clock cycles.

When enabled, the SPI controls data direction of the SPSCCK pin regardless of the state of the data direction register of the shared I/O port.

### 17.13.4 $\overline{SS}$ (Slave Select)

The  $\overline{SS}$  pin has various functions depending on the current state of the SPI. For an SPI configured as a slave, the  $\overline{SS}$  is used to select a slave. For  $CPHA = 0$ , the  $\overline{SS}$  is used to define the start of a transmission. (See [17.6 Transmission Formats](#).) Since it is used to indicate the start of a transmission, the  $\overline{SS}$  must be toggled high and low between each byte transmitted for the  $CPHA = 0$  format. However, it can remain low throughout the transmission for the  $CPHA = 1$  format. See [Figure 17-10](#).



**Figure 17-10. CPHA/ $\overline{SS}$  Timing**

When an SPI is configured as a slave, the  $\overline{SS}$  pin is always configured as an input. It cannot be used as a general-purpose I/O regardless of the state of the MODFEN control bit. However, the MODFEN bit can still prevent the state of the  $\overline{SS}$  from creating a MODF error. (See [17.14.2 SPI Status and Control Register](#).)

**NOTE:** *A logic 1 voltage on the  $\overline{SS}$  pin of a slave SPI puts the MISO pin in a high-impedance state. The slave SPI ignores all incoming SPSCK clocks, even if a transmission already has begun.*

When an SPI is configured as a master, the  $\overline{SS}$  input can be used in conjunction with the MODF flag to prevent multiple masters from driving MOSI and SPSCK. (See [17.7.2 Mode Fault Error](#).) For the state of the  $\overline{SS}$  pin to set the MODF flag, the MODFEN bit in the SPSCK register must be set. If the MODFEN bit is low for an SPI master, the  $\overline{SS}$  pin can be used as a general-purpose I/O under the control of the data direction register of the shared I/O port. With MODFEN high, it is an input-only pin to the SPI regardless of the state of the data direction register of the shared I/O port.

The CPU can always read the state of the  $\overline{SS}$  pin by configuring the appropriate pin as an input and reading the data register. (See [Table 17-5](#).)

**Table 17-5. SPI Configuration**

SPE	SPMSTR	MODFEN	SPI Configuration	State of $\overline{SS}$ Logic
0	X	X	Not Enabled	General-Purpose I/O; $\overline{SS}$ Ignored by SPI
1	0	X	Slave	Input-Only to SPI
1	1	0	Master without MODF	General-Purpose I/O; $\overline{SS}$ Ignored by SPI
1	1	1	Master with MODF	Input-Only to SPI

X = don't care

### 17.13.5 $V_{SS}$ (Clock Ground)

$V_{SS}$  is the ground return for the serial clock pin, SPSCCK, and the ground for the port output buffers. To reduce the ground return path loop and minimize radio frequency (RF) emissions, connect the ground pin of the slave to the  $V_{SS}$  pin.

### 17.14 I/O Registers

Three registers control and monitor SPI operation:

- SPI control register (SPCR \$0010)
- SPI status and control register (SPSCR \$0011)
- SPI data register (SPDR \$0012)

### 17.14.1 SPI Control Register

The SPI control register:

- Enables SPI module interrupt requests
- Selects CPU interrupt requests
- Configures the SPI module as master or slave
- Selects serial clock polarity and phase
- Configures the SPSCK, MOSI, and MISO pins as open-drain outputs
- Enables the SPI module

Address: \$0010

	Bit 7	6	5	4	3	2	1	Bit 0
Read:	SPRIE	R	SPMSTR	CPOL	CPHA	SPWOM	SPE	SPTIE
Write:								
Reset:	0	0	1	0	1	0	0	0

R = Reserved

**Figure 17-11. SPI Control Register (SPCR)**

#### SPRIE — SPI Receiver Interrupt Enable Bit

This read/write bit enables CPU interrupt requests generated by the SPRF bit. The SPRF bit is set when a byte transfers from the shift register to the receive data register. Reset clears the SPRIE bit.

- 1 = SPRF CPU interrupt requests enabled
- 0 = SPRF CPU interrupt requests disabled

#### SPMSTR — SPI Master Bit

This read/write bit selects master mode operation or slave mode operation. Reset sets the SPMSTR bit.

- 1 = Master mode
- 0 = Slave mode

**CPOL — Clock Polarity Bit**

This read/write bit determines the logic state of the SPSCCK pin between transmissions. (See [Figure 17-3](#) and [Figure 17-4](#).) To transmit data between SPI modules, the SPI modules must have identical CPOL bits. Reset clears the CPOL bit.

**CPHA — Clock Phase Bit**

This read/write bit controls the timing relationship between the serial clock and SPI data. (See [Figure 17-3](#) and [Figure 17-4](#).) To transmit data between SPI modules, the SPI modules must have identical CPHA bits. When CPHA = 0, the  $\overline{SS}$  pin of the slave SPI module must be set to logic 1 between bytes. (See [Figure 17-10](#).) Reset sets the CPHA bit.

When CPHA = 0 for a slave, the falling edge of  $\overline{SS}$  indicates the beginning of the transmission. This causes the SPI to leave its idle state and begin driving the MISO pin with the MSB of its data. Once the transmission begins, no new data is allowed into the shift register from the data register. Therefore, the slave data register must be loaded with the desired transmit data before the falling edge of  $\overline{SS}$ . Any data written after the falling edge is stored in the data register and transferred to the shift register at the current transmission.

When CPHA = 1 for a slave, the first edge of the SPSCCK indicates the beginning of the transmission. The same applies when  $\overline{SS}$  is high for a slave. The MISO pin is held in a high-impedance state, and the incoming SPSCCK is ignored. In certain cases, it may also cause the MODF flag to be set. (See [17.7.2 Mode Fault Error](#).) A logic 1 on the  $\overline{SS}$  pin does not in any way affect the state of the SPI state machine.

**SPWOM — SPI Wired-OR Mode Bit**

This read/write bit disables the pullup devices on pins SPSCCK, MOSI, and MISO so that those pins become open-drain outputs.

1 = Wired-OR SPSCCK, MOSI, and MISO pins

0 = Normal push-pull SPSCCK, MOSI, and MISO pins



#### SPE — SPI Enable Bit

This read/write bit enables the SPI module. Clearing SPE causes a partial reset of the SPI. (See [17.10 Resetting the SPI](#).) Reset clears the SPE bit.

- 1 = SPI module enabled
- 0 = SPI module disabled

#### SPTIE — SPI Transmit Interrupt Enable Bit

This read/write bit enables CPU interrupt requests generated by the SPTE bit. SPTE is set when a byte transfers from the transmit data register to the shift register. Reset clears the SPTIE bit.

- 1 = SPTE CPU interrupt requests enabled
- 0 = SPTE CPU interrupt requests disabled

### 17.14.2 SPI Status and Control Register

The SPI status and control register contains flags to signal the following conditions:

- Receive data register full
- Failure to clear SPRF bit before next byte is received (overflow error)
- Inconsistent logic level on  $\overline{SS}$  pin (mode fault error)
- Transmit data register empty

The SPI status and control register also contains bits that perform these functions:

- Enable error interrupts
- Enable mode fault error detection
- Select master SPI baud rate

Address: \$0011

	Bit 7	6	5	4	3	2	1	Bit 0
Read:	SPRF	ERRIE	OVRF	MODF	SPTF	MODFEN	SPR1	SPR0
Write:	R		R	R	R			
Reset:	0	0	0	0	1	0	0	0

R = Reserved

**Figure 17-12. SPI Status and Control Register (SPSCR)**

### SPRF — SPI Receiver Full Bit

This clearable, read-only flag is set each time a byte transfers from the shift register to the receive data register. SPRF generates a CPU interrupt request if the SPRIE bit in the SPI control register is set also. During an SPRF CPU interrupt, the CPU clears SPRF by reading the SPI status and control register with SPRF set and then reading the SPI data register. Any read of the SPI data register clears the SPRF bit.

Reset clears the SPRF bit.

- 1 = Receive data register full
- 0 = Receive data register not full

### ERRIE — Error Interrupt Enable Bit

This read-only bit enables the MODF and OVRF flags to generate CPU interrupt requests. Reset clears the ERRIE bit.

- 1 = MODF and OVRF can generate CPU interrupt requests
- 0 = MODF and OVRF cannot generate CPU interrupt requests

### OVRF — Overflow Bit

This clearable, read-only flag is set if software does not read the byte in the receive data register before the next byte enters the shift register. In an overflow condition, the byte already in the receive data register is unaffected, and the byte that shifted in last is lost. Clear the OVRF bit by reading the SPI status and control register with OVRF set and then reading the SPI data register. Reset clears the OVRF flag.

- 1 = Overflow
- 0 = No overflow

### MODF — Mode Fault Bit

This clearable, read-only flag is set in a slave SPI if the  $\overline{SS}$  pin goes high during a transmission. In a master SPI, the MODF flag is set if the  $\overline{SS}$  pin goes low at any time. Clear the MODF bit by reading the SPI status and control register with MODF set and then writing to the SPI data register. Reset clears the MODF bit.

1 =  $\overline{SS}$  pin at inappropriate logic level

0 =  $\overline{SS}$  pin at appropriate logic level

### SPTE — SPI Transmitter Empty Bit

This clearable, read-only flag is set each time the transmit data register transfers a byte into the shift register. SPTE generates an SPTE CPU interrupt request if the SPTIE bit in the SPI control register is set also.

**NOTE:** *Do not write to the SPI data register unless the SPTE bit is high.*

For an idle master or idle slave that has no data loaded into its transmit buffer, the SPTE will be set again within two bus cycles since the transmit buffer empties into the shift register. This allows the user to queue up a 16-bit value to send. For an already active slave, the load of the shift register cannot occur until the transmission is completed. This implies that a back-to-back write to the transmit data register is not possible. The SPTE indicates when the next write can occur.

Reset sets the SPTE bit.

1 = Transmit data register empty

0 = Transmit data register not empty

### MODFEN — Mode Fault Enable Bit

This read/write bit, when set to 1, allows the MODF flag to be set. If the MODF flag is set, clearing the MODFEN does not clear the MODF flag. If the SPI is enabled as a master and the MODFEN bit is low, then the  $\overline{SS}$  pin is available as a general-purpose I/O.

If the MODFEN bit is set, then this pin is not available as a general purpose I/O. When the SPI is enabled as a slave, the  $\overline{SS}$  pin is not available as a general-purpose I/O regardless of the value of MODFEN. (See [17.13.4 SS \(Slave Select\)](#).)

If the MODFEN bit is low, the level of the  $\overline{SS}$  pin does not affect the operation of an enabled SPI configured as a master. For an enabled SPI configured as a slave, having MODFEN low only prevents the MODF flag from being set. It does not affect any other part of SPI operation. (See [17.7.2 Mode Fault Error](#).)

### SPR1 and SPR0 — SPI Baud Rate Select Bits

In master mode, these read/write bits select one of four baud rates as shown in [Table 17-6](#). SPR1 and SPR0 have no effect in slave mode. Reset clears SPR1 and SPR0.

**Table 17-6. SPI Master Baud Rate Selection**

SPR1:SPR0	Baud Rate Divisor (BD)
00	2
01	8
10	32
11	128

Use this formula to calculate the SPI baud rate:

$$\text{Baud rate} = \frac{\text{CGMOUT}}{2 \times \text{BD}} = \frac{\text{Bus clock}}{\text{BD}}$$

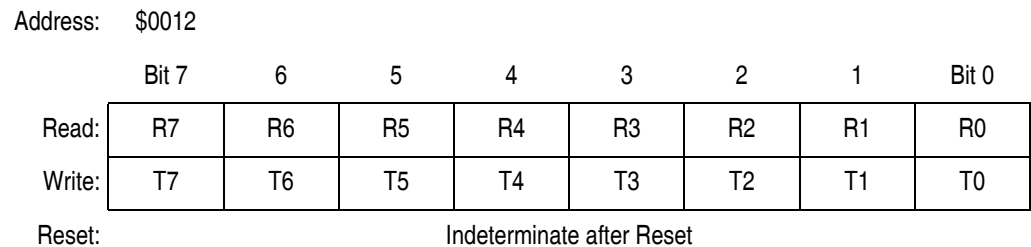
where:

CGMOUT = base clock output of the clock generator module (CGM), see [Section 8. Clock Generator Module \(CGM\)](#).

BD = baud rate divisor

### 17.14.3 SPI Data Register

The SPI data register is the read/write buffer for the receive data register and the transmit data register. Writing to the SPI data register writes data into the transmit data register. Reading the SPI data register reads data from the receive data register. The transmit data and receive data registers are separate buffers that can contain different values. See [Figure 17-1](#).



**Figure 17-13. SPI Data Register (SPDR)**

R7–R0/T7–T0 — Receive/Transmit Data Bits

**NOTE:** Do not use read-modify-write instructions on the SPI data register since the buffer read is not the same as the buffer written.



## Serial Peripheral Interface (SPI)

## Controller Area Network (CAN) 64-Pin Quad Flat Pack

*The following section of modules is MC68HC08AZ32 Emulator (64-Pin QFP) protocol specific. References to an earlier section are provided for those modules that are common to both the MC68HC08AZ32 Emulator (64-Pin QFP) protocol and the MC68HC08AS20 Emulator (52-Pin PLCC) protocol.*



# Controller Area Network (CAN) 64-Pin Quad Flat Pack



## Section 18. Timer Interface (TIMA-4)

**NOTE:** This timer is for the *MC68HC08AZ32 emulator* protocol only.

### 18.1 Contents

18.2	Introduction .....	290
18.3	Features .....	290
18.4	Functional Description .....	294
18.4.1	TIMA Counter Prescaler .....	294
18.4.2	Input Capture .....	294
18.4.3	Output Compare .....	296
18.4.3.1	Unbuffered Output Compare .....	296
18.4.3.2	Buffered Output Compare .....	297
18.4.4	Pulse Width Modulation (PWM) .....	298
18.4.4.1	Unbuffered PWM Signal Generation .....	299
18.4.4.2	Buffered PWM Signal Generation .....	300
18.4.4.3	PWM Initialization .....	301
18.5	Interrupts .....	302
18.6	Low-Power Modes .....	303
18.6.1	Wait Mode .....	303
18.6.2	Stop Mode .....	303
18.7	TIMA During Break Interrupts .....	303
18.8	I/O Signals .....	304
18.8.1	TIMA Clock Pin (PTD6/ATD14/TCLK) .....	304
18.8.2	TIMA Channel I/O Pins (PTF1/TACH3–PTF0/TACH2 and PTE3/TACH1–PTE2/TACH0) .....	305
18.9	I/O Registers .....	305
18.9.1	TIMA Status and Control Register .....	305

18.9.2	TIMA Counter Registers . . . . .	308
18.9.3	TIMA Counter Modulo Registers . . . . .	309
18.9.4	TIMA Channel Status and Control Registers . . . . .	310
18.9.5	TIMA Channel Registers . . . . .	315

## 18.2 Introduction

This section describes the timer interface module (TIMA-4). The TIMA is a 4-channel timer that provides a timing reference with input capture, output compare, and pulse width modulation functions. **Figure 18-1** is a block diagram of the TIMA.

## 18.3 Features

Features of the TIMA include:

- Four Input Capture/Output Compare Channels
  - Rising-Edge, Falling-Edge, or Any-Edge Input Capture Trigger
  - Set, Clear, or Toggle Output Compare Action
- Buffered and Unbuffered Pulse Width Modulation (PWM) Signal Generation
- Programmable TIMA Clock Input
  - 7-Frequency Internal Bus Clock Prescaler Selection
  - External TIMA Clock Input (4-MHz Maximum Frequency)
- Free-Running or Modulo Up-Count Operation
- Toggle Any Channel Pin on Overflow
- TIMA Counter Stop and Reset Bits

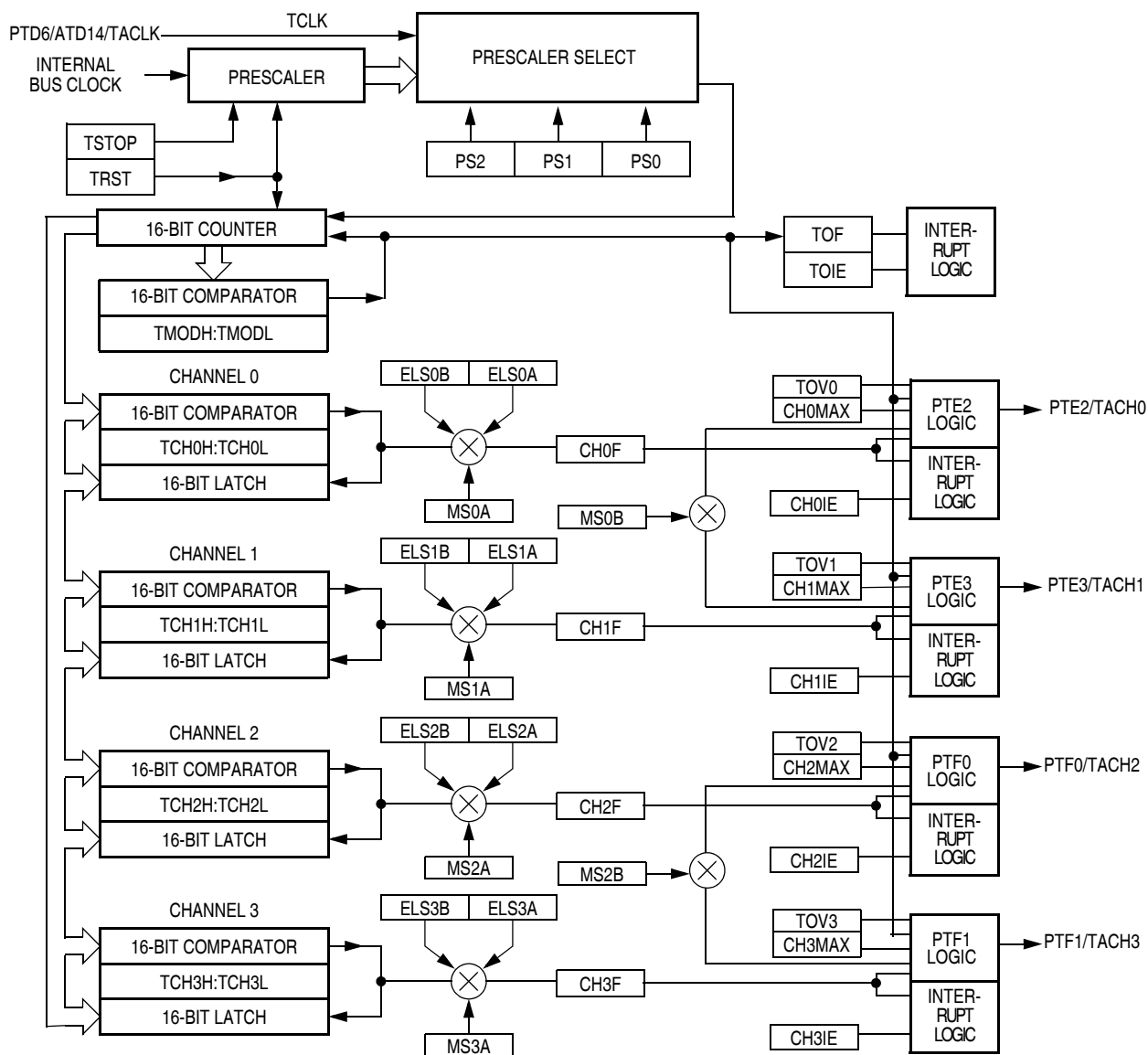


Figure 18-1. TIMA Block Diagram

### Table 18-1. TIM I/O Register Summary

Addr.	Register Name	Bit 7	6	5	4	3	2	1	Bit 0	
\$0020	Timer A Status and Control Register (TASC)	Read:	TOF	TOIE	TSTOP	0	0	PS2	PS1	PS0
		Write:	0			TRST	R			
		Reset:	0	0	1	0	0	0	0	0
\$0021	Keyboard Interrupt Control Register (KBIER)	Read:	0	0	0	KBIE4	KBIE3	KBIE2	KBIE1	KBIE0
		Write:								
		Reset:	0	0	0	0	0	0	0	0
\$0022	Timer A Counter Register High (TACNTH)	Read:	Bit 15	14	13	12	11	10	9	Bit 8
		Write:	R	R	R	R	R	R	R	R
		Reset:	0	0	0	0	0	0	0	0
\$0023	Timer A Counter Register Low (TACNTL)	Read:	Bit 7	6	5	4	3	2	1	Bit 0
		Write:	R	R	R	R	R	R	R	R
		Reset:	0	0	0	0	0	0	0	0
\$0024	Timer A Modulo Register High (TAMODH)	Read:	Bit 15	14	13	12	11	10	9	Bit 8
		Write:								
		Reset:	1	1	1	1	1	1	1	1
\$0025	Timer A Modulo Register Low (TAMODL)	Read:	Bit 7	6	5	4	3	2	1	Bit 0
		Write:								
		Reset:	1	1	1	1	1	1	1	1
\$0026	Timer A Channel 0 Status and Control Register (TASC0)	Read:	CH0F	CH0IE	MS0B	MS0A	ELS0B	ELS0A	TOV0	CH0MAX
		Write:	0							
		Reset:	0	0	0	0	0	0	0	0
\$0027	Timer A Channel 0 Register High (TACH0H)	Read:	Bit 15	14	13	12	11	10	9	Bit 8
		Write:								
		Reset:	Indeterminate after Reset							
\$0028	Timer A Channel 0 Register Low (TACH0L)	Read:	Bit 7	6	5	4	3	2	1	Bit 0
		Write:								
		Reset:	Indeterminate after Reset							
\$0029	Timer A Channel 1 Status and Control Register (TASC1)	Read:	CH1F	CH1IE	0	MS1A	ELS1B	ELS1A	TOV1	CH1MAX
		Write:	0		R					
		Reset:	0	0	0	0	0	0	0	0

= Unimplemented    
R = Reserved

**Table 18-1. TIM I/O Register Summary**

\$002A	Timer A Channel 1 Register High (TACH1H)	Read:	Bit 15	14	13	12	11	10	9	Bit 8
		Write:								
		Reset:	Indeterminate after Reset							
\$002B	Timer A Channel 1 Register Low (TACH1L)	Read:	Bit 7	6	5	4	3	2	1	Bit 0
		Write:								
		Reset:	Indeterminate after Reset							
\$002C	Timer A Channel 2 Status and Control Register (TASC2)	Read:	CH2F	CH2IE	MS2B	MS2A	ELS2B	ELS2A	TOV2	CH2MAX
		Write:	0							
		Reset:	0	0	0	0	0	0	0	0
\$002D	Timer A Channel 2 Register High (TACH2H)	Read:	Bit 15	14	13	12	11	10	9	Bit 8
		Write:								
		Reset:	Indeterminate after Reset							
\$002E	Timer A Channel 2 Register Low (TACH2L)	Read:	Bit 7	6	5	4	3	2	1	Bit 0
		Write:								
		Reset:	Indeterminate after Reset							
\$002F	Timer A Channel 3 Status and Control Register (TASC3)	Read:	CH3F	CH3IE	0	MS3A	ELS3B	ELS3A	TOV3	CH3MAX
		Write:	0		R					
		Reset:	0	0	0	0	0	0	0	0
\$0030	Timer A Channel 3 Register High (TACH3H)	Read:	Bit 15	14	13	12	11	10	9	Bit 8
		Write:								
		Reset:	Indeterminate after Reset							
\$0031	Timer A Channel 3 Register Low (TACH3L)	Read:	Bit 7	6	5	4	3	2	1	Bit 0
		Write:								
		Reset:	Indeterminate after Reset							

= Unimplemented    
 R = Reserved

## 18.4 Functional Description

**Figure 18-1** shows the TIMA structure. The central component of the TIMA is the 16-bit TIMA counter that can operate as a free-running counter or a modulo up-counter. The TIMA counter provides the timing reference for the input capture and output compare functions. The TIMA counter modulo registers, TAMODH–TAMODL, control the modulo value of the TIMA counter. Software can read the TIMA counter value at any time without affecting the counting sequence.

The four TIMA channels are programmable independently as input capture or output compare channels.

### 18.4.1 TIMA Counter Prescaler

The TIMA clock source can be one of the seven prescaler outputs or the TIMA clock pin, PTD6/ATD14/TACLK. The prescaler generates seven clock rates from the internal bus clock. The prescaler select bits, PS[2:0], in the TIMA status and control register select the TIMA clock source.

### 18.4.2 Input Capture

An input capture function has three basic parts: edge select logic, an input capture latch, and a 16-bit counter. Two 8-bit registers, which make up the 16-bit input capture register, are used to latch the value of the free-running counter after the corresponding input capture edge detector senses a defined transition. The polarity of the active edge is programmable. The level transition which triggers the counter transfer is defined by the corresponding input edge bits (ELSxB and ELSxA in TASC0 through TASC3 control registers with x referring to the active channel number). When an active edge occurs on the pin of an input capture channel, the TIMA latches the contents of the TIMA counter into the TIMA channel registers, TACHxH–TACHxL. Input captures can generate TIMA CPU interrupt requests. Software can determine that an input capture event has occurred by enabling input capture interrupts or by polling the status flag bit.

The result obtained by an input capture will be two more than the value of the free-running counter on the rising edge of the internal bus clock preceding the external transition. This delay is required for internal synchronization.

The free-running counter contents are transferred to the TIMA channel status and control register (TACHxH–TACHxL, see [18.9.5 TIMA Channel Registers](#)) on each proper signal transition regardless of whether the TIMA channel flag (CH0F–CH5F in TASC0–TASC5 registers) is set or clear. When the status flag is set, a CPU interrupt is generated if enabled. The value of the count latched or “captured” is the time of the event. Because this value is stored in the input capture register 2 bus cycles after the actual event occurs, user software can respond to this event at a later time and determine the actual time of the event. However, this must be done prior to another input capture on the same pin; otherwise, the previous time value will be lost.

By recording the times for successive edges on an incoming signal, software can determine the period and/or pulse width of the signal. To measure a period, two successive edges of the same polarity are captured. To measure a pulse width, two alternate polarity edges are captured. Software should track the overflows at the 16-bit module counter to extend its range.

Another use for the input capture function is to establish a time reference. In this case, an input capture function is used in conjunction with an output compare function. For example, to activate an output signal a specified number of clock cycles after detecting an input event (edge), use the input capture function to record the time at which the edge occurred. A number corresponding to the desired delay is added to this captured value and stored to an output compare register (see [18.9.5 TIMA Channel Registers](#)). Because both input captures and output compares are referenced to the same 16-bit modulo counter, the delay can be controlled to the resolution of the counter independent of software latencies.

Reset does not affect the contents of the input capture channel registers.

### 18.4.3 Output Compare

With the output compare function, the TIMA can generate a periodic pulse with a programmable polarity, duration, and frequency. When the counter reaches the value in the registers of an output compare channel, the TIMA can set, clear, or toggle the channel pin. Output compares can generate TIMA CPU interrupt requests.

#### 18.4.3.1 Unbuffered Output Compare

Any output compare channel can generate unbuffered output compare pulses as described in [18.4.3 Output Compare](#). The pulses are unbuffered because changing the output compare value requires writing the new value over the old value currently in the TIMA channel registers.

An unsynchronized write to the TIMA channel registers to change an output compare value could cause incorrect operation for up to two counter overflow periods. For example, writing a new value before the counter reaches the old value but after the counter reaches the new value prevents any compare during that counter overflow period. Also, using a TIMA overflow interrupt routine to write a new, smaller output compare value may cause the compare to be missed. The TIMA may pass the new value before it is written.

Use the following methods to synchronize unbuffered changes in the output compare value on channel x:

- When changing to a smaller value, enable channel x output compare interrupts and write the new value in the output compare interrupt routine. The output compare interrupt occurs at the end of the current output compare pulse. The interrupt routine has until the end of the counter overflow period to write the new value.
- When changing to a larger output compare value, enable channel x TIMA overflow interrupts and write the new value in the TIMA overflow interrupt routine. The TIMA overflow interrupt occurs at the end of the current counter overflow period. Writing a larger value in an output compare interrupt routine (at the end of the current pulse) could cause two output compares to occur in the same counter overflow period.



### 18.4.3.2 Buffered Output Compare

Channels 0 and 1 can be linked to form a buffered output compare channel whose output appears on the PTE2/TACH0 pin. The TIMA channel registers of the linked pair alternately control the output.

Setting the MS0B bit in TIMA channel 0 status and control register (TASC0) links channel 0 and channel 1. The output compare value in the TIMA channel 0 registers initially controls the output on the PTE2/TACH0 pin. Writing to the TIMA channel 1 registers enables the TIMA channel 1 registers to synchronously control the output after the TIMA overflows. At each subsequent overflow, the TIMA channel registers (0 or 1) that control the output are the ones written to last. TASC0 controls and monitors the buffered output compare function, and TIMA channel 1 status and control register (TASC1) is unused. While the MS0B bit is set, the channel 1 pin, PTE3/TACH1, is available as a general-purpose I/O pin.

Channels 2 and 3 can be linked to form a buffered output compare channel whose output appears on the PTF0/TACH2 pin. The TIMA channel registers of the linked pair alternately control the output.

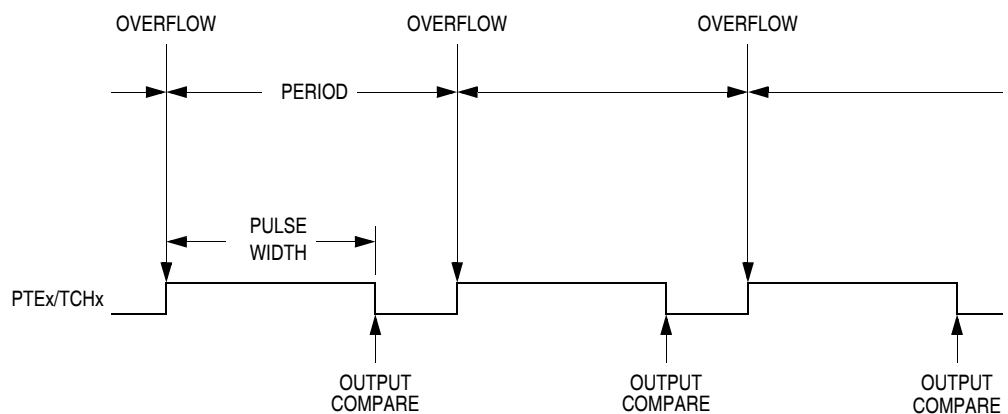
Setting the MS2B bit in TIMA channel 2 status and control register (TASC2) links channel 2 and channel 3. The output compare value in the TIMA channel 2 registers initially controls the output on the PTF0/TACH2 pin. Writing to the TIMA channel 3 registers enables the TIMA channel 3 registers to synchronously control the output after the TIMA overflows. At each subsequent overflow, the TIMA channel registers (2 or 3) that control the output are the ones written to last. TASC2 controls and monitors the buffered output compare function, and TIMA channel 3 status and control register (TASC3) is unused. While the MS2B bit is set, the channel 3 pin, PTF1/TACH3, is available as a general-purpose I/O pin.

**NOTE:** *In buffered output compare operation, do not write new output compare values to the currently active channel registers. Writing to the active channel registers is the same as generating unbuffered output compares.*

## 18.4.4 Pulse Width Modulation (PWM)

By using the toggle-on-overflow feature with an output compare channel, the TIMA can generate a PWM signal. The value in the TIMA counter modulo registers determines the period of the PWM signal. The channel pin toggles when the counter reaches the value in the TIMA counter modulo registers. The time between overflows is the period of the PWM signal.

As [Figure 18-2](#) shows, the output compare value in the TIMA channel registers determines the pulse width of the PWM signal. The time between overflow and output compare is the pulse width. Program the TIMA to clear the channel pin on output compare if the state of the PWM pulse is logic 1. Program the TIMA to set the pin if the state of the PWM pulse is logic 0.



**Figure 18-2. PWM Period and Pulse Width**

The value in the TIMA counter modulo registers and the selected prescaler output determines the frequency of the PWM output. The frequency of an 8-bit PWM signal is variable in 256 increments. Writing \$00FF (255) to the TIMA counter modulo registers produces a PWM period of 256 times the internal bus clock period if the prescaler select value is \$000 (see [18.9.1 TIMA Status and Control Register](#)).

The value in the TIMA channel registers determines the pulse width of the PWM output. The pulse width of an 8-bit PWM signal is variable in 256 increments. Writing \$0080 (128) to the TIMA channel registers produces a duty cycle of 128/256 or 50%.

### 18.4.4.1 Unbuffered PWM Signal Generation

Any output compare channel can generate unbuffered PWM pulses as described in [18.4.4 Pulse Width Modulation \(PWM\)](#). The pulses are unbuffered because changing the pulse width requires writing the new pulse width value over the value currently in the TIMA channel registers.

An unsynchronized write to the TIMA channel registers to change a pulse width value could cause incorrect operation for up to two PWM periods. For example, writing a new value before the counter reaches the old value but after the counter reaches the new value prevents any compare during that PWM period. Also, using a TIMA overflow interrupt routine to write a new, smaller pulse width value may cause the compare to be missed. The TIMA may pass the new value before it is written to the TIMA channel registers.

Use the following methods to synchronize unbuffered changes in the PWM pulse width on channel x:

- When changing to a shorter pulse width, enable channel x output compare interrupts and write the new value in the output compare interrupt routine. The output compare interrupt occurs at the end of the current pulse. The interrupt routine has until the end of the PWM period to write the new value.
- When changing to a longer pulse width, enable channel x TIMA overflow interrupts and write the new value in the TIMA overflow interrupt routine. The TIMA overflow interrupt occurs at the end of the current PWM period. Writing a larger value in an output compare interrupt routine (at the end of the current pulse) could cause two output compares to occur in the same PWM period.

**NOTE:** *In PWM signal generation, do not program the PWM channel to toggle on output compare. Toggling on output compare prevents reliable 0% duty cycle generation and removes the ability of the channel to self-correct in the event of software error or noise. Toggling on output compare also can cause incorrect PWM signal generation when changing the PWM pulse width to a new, much larger value.*

#### 18.4.4.2 Buffered PWM Signal Generation

Channels 0 and 1 can be linked to form a buffered PWM channel whose output appears on the PTE2/TACH0 pin. The TIMA channel registers of the linked pair alternately control the pulse width of the output.

Setting the MS0B bit in TIMA channel 0 status and control register (TASC0) links channel 0 and channel 1. The TIMA channel 0 registers initially control the pulse width on the PTE2/TACH0 pin. Writing to the TIMA channel 1 registers enables the TIMA channel 1 registers to synchronously control the pulse width at the beginning of the next PWM period. At each subsequent overflow, the TIMA channel registers (0 or 1) that control the pulse width are the ones written to last. TASC0 controls and monitors the buffered PWM function, and TIMA channel 1 status and control register (TASC1) is unused. While the MS0B bit is set, the channel 1 pin, PTE3/TACH1, is available as a general-purpose I/O pin.

Channels 2 and 3 can be linked to form a buffered PWM channel whose output appears on the PTF0/TACH2 pin. The TIMA channel registers of the linked pair alternately control the pulse width of the output.

Setting the MS2B bit in TIMA channel 2 status and control register (TASC2) links channel 2 and channel 3. The TIMA channel 2 registers initially control the pulse width on the PTF0/TACH2 pin. Writing to the TIMA channel 3 registers enables the TIMA channel 3 registers to synchronously control the pulse width at the beginning of the next PWM period. At each subsequent overflow, the TIMA channel registers (2 or 3) that control the pulse width are the ones written to last. TASC2 controls and monitors the buffered PWM function, and TIMA channel 3 status and control register (TASC3) is unused. While the MS2B bit is set, the channel 3 pin, PTF1/TACH3, is available as a general-purpose I/O pin.

**NOTE:** *In buffered PWM signal generation, do not write new pulse width values to the currently active channel registers. Writing to the active channel registers is the same as generating unbuffered PWM signals.*

### 18.4.4.3 PWM Initialization

To ensure correct operation when generating unbuffered or buffered PWM signals, use the following initialization procedure:

1. In the TIMA status and control register (TASC):
  - a. Stop the TIMA counter by setting the TIMA stop bit, TSTOP.
  - b. Reset the TIMA counter by setting the TIMA reset bit, TRST.
2. In the TIMA counter modulo registers (TAMODH–TAMODL), write the value for the required PWM period.
3. In the TIMA channel x registers (TACHxH–TACHxL), write the value for the required pulse width.
4. In TIMA channel x status and control register (TSCx):
  - a. Write 0:1 (for unbuffered output compare or PWM signals) or 1:0 (for buffered output compare or PWM signals) to the mode select bits, MSxB–MSxA. (See [Table 18-3](#).)
  - b. Write 1 to the toggle-on-overflow bit, TOVx.
  - c. Write 1:0 (to clear output on compare) or 1:1 (to set output on compare) to the edge/level select bits, ELSxB–ELSxA. The output action on compare must force the output to the complement of the pulse width level. (See [Table 18-3](#).)

**NOTE:** *In PWM signal generation, do not program the PWM channel to toggle on output compare. Toggling on output compare prevents reliable 0% duty cycle generation and removes the ability of the channel to self-correct in the event of software error or noise. Toggling on output compare can also cause incorrect PWM signal generation when changing the PWM pulse width to a new, much larger value.*

5. In the TIMA status control register (TASC), clear the TIMA stop bit, TSTOP.

Setting MS0B links channels 0 and 1 and configures them for buffered PWM operation. The TIMA channel 0 registers (TACH0H–TACH0L) initially control the buffered PWM output. TIMA status control register 0 (TASC0) controls and monitors the PWM signal from the linked channels. MS0B takes priority over MS0A.

Setting MS2B links channels 2 and 3 and configures them for buffered PWM operation. The TIMA channel 2 registers (TACH2H–TACH2L) initially control the PWM output. TIMA status control register 2 (TASC2) controls and monitors the PWM signal from the linked channels. MS2B takes priority over MS2A.

Clearing the toggle-on-overflow bit, TOVx, inhibits output toggles on TIMA overflows. Subsequent output compares try to force the output to a state it is already in and have no effect. The result is a 0% duty cycle output.

Setting the channel x maximum duty cycle bit (CHxMAX) and clearing the TOVx bit generates a 100% duty cycle output. (See [18.9.4 TIMA Channel Status and Control Registers](#).)

## 18.5 Interrupts

The following TIMA sources can generate interrupt requests:

- TIMA overflow flag (TOF) — The TOF bit is set when the TIMA counter value rolls over to \$0000 after matching the value in the TIMA counter modulo registers. The TIMA overflow interrupt enable bit, TOIE, enables TIMA overflow CPU interrupt requests. TOF and TOIE are in the TIMA status and control register.
- TIMA channel flags (CH3F–CH0F) — The CHxF bit is set when an input capture or output compare occurs on channel x. Channel x TIMA CPU interrupt requests are controlled by the channel x interrupt enable bit, CHxIE.

## 18.6 Low-Power Modes

The WAIT and STOP instructions put the MCU in low-power standby modes.

### 18.6.1 Wait Mode

The TIMA remains active after the execution of a WAIT instruction. In wait mode, the TIMA registers are not accessible by the CPU. Any enabled CPU interrupt request from the TIMA can bring the MCU out of wait mode.

If TIMA functions are not required during wait mode, reduce power consumption by stopping the TIMA before executing the WAIT instruction.

### 18.6.2 Stop Mode

The TIMA is inactive after the execution of a STOP instruction. The STOP instruction does not affect register conditions or the state of the TIMA counter. TIMA operation resumes when the MCU exits stop mode.

## 18.7 TIMA During Break Interrupts

A break interrupt stops the TIMA counter and inhibits input captures.

The system integration module (SIM) controls whether status bits in other modules can be cleared during the break state. The BCFE bit in the SIM break flag control register (SBFCR) enables software to clear status bits during the break state. (See [7.8.3 SIM Break Flag Control Register](#).)

To allow software to clear status bits during a break interrupt, write a logic 1 to the BCFE bit. If a status bit is cleared during the break state, it remains cleared when the MCU exits the break state.

To protect status bits during the break state, write a logic 0 to the BCFE bit. With BCFE at logic 0 (its default state), software can read and write

I/O registers during the break state without affecting status bits. Some status bits have a 2-step read/write clearing procedure. If software does the first step on such a bit before the break, the bit cannot change during the break state as long as BCFE is at logic 0. After the break, doing the second step clears the status bit.

## 18.8 I/O Signals

Port D shares one of its pins with the TIMA. Port E shares two of its pins with the TIMA and port F shares two of its pins with the TIMA. PTD6/ATD14/TACLK is an external clock input to the TIMA prescaler. The four TIMA channel I/O pins are PTE2/TACH0, PTE3/TACH1, PTF0/TACH2, and PTF1/TACH3.

### 18.8.1 TIMA Clock Pin (PTD6/ATD14/TCLK)

PTD6/ATD14/TACLK is an external clock input that can be the clock source for the TIMA counter instead of the prescaled internal bus clock. Select the PTD6/ATD14/TACLK input by writing logic 1s to the three prescaler select bits, PS[2:0]. (See [18.9.1 TIMA Status and Control Register](#).) The minimum TCLK pulse width,  $TCLK_{LMIN}$  or  $TCLK_{HMIN}$ , is:

$$\frac{1}{\text{bus frequency}} + t_{SU}$$

The maximum TCLK frequency is the least: 4 MHz or bus frequency  $\div$  2.

PTD6/ATD14/TACLK is available as a general-purpose I/O pin or ADC channel when not used as the TIMA clock input. When the PTD6/ATD14/TACLK pin is the TIMA clock input, it is an input regardless of the state of the DDRD6 bit in data direction register D.



### 18.8.2 TIMA Channel I/O Pins (PTF1/TACH3–PTF0/TACH2 and PTE3/TACH1–PTE2/TACH0)

Each channel I/O pin is programmable independently as an input capture pin or an output compare pin. PTE2/TACH0 and PTF0/TACH2 can be configured as buffered output compare or buffered PWM pins.

## 18.9 I/O Registers

These I/O registers control and monitor TIMA operation:

- TIMA status and control register (TASC)
- TIMA control registers (TACNTH–TACNTL)
- TIMA counter modulo registers (TAMODH–TAMODL)
- TIMA channel status and control registers (TASC0, TASC1, TASC2, and TASC3)
- TIMA channel registers (TACH0H–TACH0L, TACH1H–TACH1L, TACH2H–TACH2L, and TACH3H–TACH3L)

### 18.9.1 TIMA Status and Control Register

The TIMA status and control register:

- Enables TIMA overflow interrupts
- Flags TIMA overflows
- Stops the TIMA counter
- Resets the TIMA counter
- Prescales the TIMA counter clock

Address: \$0020

	Bit 7	6	5	4	3	2	1	Bit 0
Read:	TOF	TOIE	TSTOP	0	0	PS2	PS1	PS0
Write:	0			TRST	R			
Reset:	0	0	1	0	0	0	0	0

R = Reserved

**Figure 18-3. TIMA Status and Control Register (TASC)**

### TOF — TIMA Overflow Flag Bit

This read/write flag is set when the TIMA counter resets to \$0000 after reaching the modulo value programmed in the TIMA counter modulo registers. Clear TOF by reading the TIMA status and control register when TOF is set and then writing a logic 0 to TOF. If another TIMA overflow occurs before the clearing sequence is complete, then writing logic 0 to TOF has no effect. Therefore, a TOF interrupt request cannot be lost due to inadvertent clearing of TOF. Reset clears the TOF bit. Writing a logic 1 to TOF has no effect.

- 1 = TIMA counter has reached modulo value
- 0 = TIMA counter has not reached modulo value

### TOIE — TIMA Overflow Interrupt Enable Bit

This read/write bit enables TIMA overflow interrupts when the TOF bit becomes set. Reset clears the TOIE bit.

- 1 = TIMA overflow interrupts enabled
- 0 = TIMA overflow interrupts disabled

### TSTOP — TIMA Stop Bit

This read/write bit stops the TIMA counter. Counting resumes when TSTOP is cleared. Reset sets the TSTOP bit, stopping the TIMA counter until software clears the TSTOP bit.

- 1 = TIMA counter stopped
- 0 = TIMA counter active

**NOTE:** *Do not set the TSTOP bit before entering wait mode if the TIMA is required to exit wait mode. Also when the TSTOP bit is set and the timer is configured for input capture operation, input captures are inhibited until the TSTOP bit is cleared.*

### TRST — TIMA Reset Bit

Setting this write-only bit resets the TIMA counter and the TIMA prescaler. Setting TRST has no effect on any other registers. Counting resumes from \$0000. TRST is cleared automatically after the TIMA counter is reset and always reads as logic 0. Reset clears the TRST bit.

- 1 = Prescaler and TIMA counter cleared
- 0 = No effect

**NOTE:** *Setting the TSTOP and TRST bits simultaneously stops the TIMA counter at a value of \$0000.*

### PS[2:0] — Prescaler Select Bits

These read/write bits select either the PTD6/ATD14/TACLK pin or one of the seven prescaler outputs as the input to the TIMA counter as [Table 18-2](#) shows. Reset clears the PS[2:0] bits.

**Table 18-2. Prescaler Selection**

PS[2:0]	TIMA Clock Source
000	Internal Bus Clock ÷ 1
001	Internal Bus Clock ÷ 2
010	Internal Bus Clock ÷ 4
011	Internal Bus Clock ÷ 8
100	Internal Bus Clock ÷ 16
101	Internal Bus Clock ÷ 32
110	Internal Bus Clock ÷ 64
111	PTD6/ATD14/TACLK

## 18.9.2 TIMA Counter Registers

The two read-only TIMA counter registers contain the high and low bytes of the value in the TIMA counter. Reading the high byte (TACNTH) latches the contents of the low byte (TACNTL) into a buffer. Subsequent reads of TACNTH do not affect the latched TACNTL value until TACNTL is read. Reset clears the TIMA counter registers. Setting the TIMA reset bit (TRST) also clears the TIMA counter registers.

**NOTE:** *If TACNTH is read during a break interrupt, be sure to unlatch TACNTL by reading TACNTL before exiting the break interrupt. Otherwise, TACNTL retains the value latched during the break.*

Register Name and Address: TACNTH — \$0022

	Bit 7	6	5	4	3	2	1	Bit 0
Read:	BIT 15	BIT 14	BIT 13	BIT 12	BIT 11	BIT 10	BIT 9	BIT 8
Write:	R	R	R	R	R	R	R	R
Reset:	0	0	0	0	0	0	0	0

Register Name and Address: TACNTL — \$0023

	Bit 7	6	5	4	3	2	1	Bit 0
Read:	BIT 7	BIT 6	BIT 5	BIT 4	BIT 3	BIT 2	BIT 1	BIT 0
Write:	R	R	R	R	R	R	R	R
Reset:	0	0	0	0	0	0	0	0

R
---

 = Reserved

**Figure 18-4. TIMA Counter Registers (TACNTH and TACNTL)**

### 18.9.3 TIMA Counter Modulo Registers

The read/write TIMA modulo registers contain the modulo value for the TIMA counter. When the TIMA counter reaches the modulo value, the overflow flag (TOF) becomes set, and the TIMA counter resumes counting from \$0000 at the next clock. Writing to the high byte (TAMODH) inhibits the TOF bit and overflow interrupts until the low byte (TAMODL) is written. Reset sets the TIMA counter modulo registers.

Register Name and Address: TAMODH — \$0024

	Bit 7	6	5	4	3	2	1	Bit 0
Read:	BIT 15	BIT 14	BIT 13	BIT 12	BIT 11	BIT 10	BIT 9	BIT 8
Write:								
Reset:	1	1	1	1	1	1	1	1

Register Name and Address: TAMODL — \$0025

	Bit 7	6	5	4	3	2	1	Bit 0
Read:	BIT 7	BIT 6	BIT 5	BIT 4	BIT 3	BIT 2	BIT 1	BIT 0
Write:								
Reset:	1	1	1	1	1	1	1	1

**Figure 18-5. TIMA Counter Modulo Registers (TAMODH and TAMODL)**

**NOTE:** *Reset the TIMA counter before writing to the TIMA counter modulo registers.*

## 18.9.4 TIMA Channel Status and Control Registers

Each of the TIMA channel status and control registers:

- Flags input captures and output compares
- Enables input capture and output compare interrupts
- Selects input capture, output compare, or PWM operation
- Selects high, low, or toggling output on output compare
- Selects rising edge, falling edge, or any edge as the active input capture trigger
- Selects output toggling on TIMA overflow
- Selects 100% PWM duty cycle
- Selects buffered or unbuffered output compare/PWM operation

Register Name and Address: TASC0 — \$0026

	Bit 7	6	5	4	3	2	1	Bit 0
Read:	CH0F	CH0IE	MS0B	MS0A	ELS0B	ELS0A	TOV0	CH0MAX
Write:	0							
Reset:	0	0	0	0	0	0	0	0

Register Name and Address: TASC1 — \$0029

	Bit 7	6	5	4	3	2	1	Bit 0
Read:	CH1F	CH1IE	0	MS1A	ELS1B	ELS1A	TOV1	CH1MAX
Write:	0		R					
Reset:	0	0	0	0	0	0	0	0

R = Reserved

**Figure 18-6. TIMA Channel Status and Control Registers (TASC0–TASC3)**

Register Name and Address: TASC2 — \$002C

	Bit 7	6	5	4	3	2	1	Bit 0
Read:	CH2F	CH2IE	MS2B	MS2A	ELS2B	ELS2A	TOV2	CH2MAX
Write:	0							
Reset:	0	0	0	0	0	0	0	0

Register Name and Address: TASC3 — \$002F

	Bit 7	6	5	4	3	2	1	Bit 0
Read:	CH3F	CH3IE	0	MS3A	ELS3B	ELS3A	TOV3	CH3MAX
Write:	0		R					
Reset:	0	0	0	0	0	0	0	0

R	= Reserved
---	------------

**Figure 18-6. TIMA Channel Status and Control Registers (TASC0–TASC3) (Continued)**

**CHxF — Channel x Flag Bit**

When channel x is an input capture channel, this read/write bit is set when an active edge occurs on the channel x pin. When channel x is an output compare channel, CHxF is set when the value in the TIMA counter registers matches the value in the TIMA channel x registers.

When CHxIE = 0, clear CHxF by reading TIMA channel x status and control register with CHxF set, and then writing a logic 0 to CHxF. If another interrupt request occurs before the clearing sequence is complete, then writing logic 0 to CHxF has no effect. Therefore, an interrupt request cannot be lost due to inadvertent clearing of CHxF.

Reset clears the CHxF bit. Writing a logic 1 to CHxF has no effect.

1 = Input capture or output compare on channel x

0 = No input capture or output compare on channel x

**CHxIE — Channel x Interrupt Enable Bit**

This read/write bit enables TIMA CPU interrupts on channel x.

Reset clears the CHxIE bit.

1 = Channel x CPU interrupt requests enabled

0 = Channel x CPU interrupt requests disabled

**MSxB — Mode Select Bit B**

This read/write bit selects buffered output compare/PWM operation. MSxB exists only in the TIMA channel 0 and TIMA channel 2 status and control registers.

Setting MS0B disables the channel 1 status and control register and reverts TACH1 pin to general-purpose I/O.

Setting MS2B disables the channel 3 status and control register and reverts TACH3 pin to general-purpose I/O.

Reset clears the MSxB bit.

1 = Buffered output compare/PWM operation enabled

0 = Buffered output compare/PWM operation disabled



### MSxA — Mode Select Bit A

When ELSxB:A  $\neq$  00, this read/write bit selects either input capture operation or unbuffered output compare/PWM operation. (See [Table 18-3](#).)

- 1 = Unbuffered output compare/PWM operation
- 0 = Input capture operation

When ELSxB:A = 00, this read/write bit selects the initial output level of the TCHx pin once PWM, input capture, or output compare operation is enabled. (See [Table 18-3](#).) Reset clears the MSxA bit.

- 1 = Initial output level low
- 0 = Initial output level high

**NOTE:** *Before changing a channel function by writing to the MSxB or MSxA bit, set the TSTOP and TRST bits in the TIMA status and control register (TASC).*

### ELSxB and ELSxA — Edge/Level Select Bits

When channel x is an input capture channel, these read/write bits control the active edge-sensing logic on channel x.

When channel x is an output compare channel, ELSxB and ELSxA control the channel x output behavior when an output compare occurs.

When ELSxB and ELSxA are both clear, channel x is not connected to port E or port F, and pin PTE<sub>x</sub>/TACH<sub>x</sub> or pin PTF<sub>x</sub>/TACH<sub>x</sub> is available as a general-purpose I/O pin. However, channel x is at a state determined by these bits and becomes transparent to the respective pin when PWM, input capture, or output compare mode is enabled. [Table 18-3](#) shows how ELSxB and ELSxA work. Reset clears the ELSxB and ELSxA bits.

**Table 18-3. Mode, Edge, and Level Selection**

MSxB:MSxA	ELSxB:ELSxA	Mode	Configuration
X0	00	Output Preset	Pin under Port Control; Initialize Timer Output Level High
X1	00		Pin under Port Control; Initialize Timer Output Level Low
00	01	Input Capture	Capture on Rising Edge Only
00	10		Capture on Falling Edge Only
00	11		Capture on Rising or Falling Edge
01	01	Output Compare or PWM	Toggle Output on Compare
01	10		Clear Output on Compare
01	11		Set Output on Compare
1X	01	Buffered Output Compare or Buffered PWM	Toggle Output on Compare
1X	10		Clear Output on Compare
1X	11		Set Output on Compare

**NOTE:** Before enabling a TIMA channel register for input capture operation, make sure that the PTE<sub>x</sub>/TACH<sub>x</sub> pin or PTF<sub>x</sub>/TACH<sub>x</sub> pin is stable for at least two bus clocks.

### TOV<sub>x</sub> — Toggle-On-Overflow Bit

When channel x is an output compare channel, this read/write bit controls the behavior of the channel x output when the TIMA counter overflows. When channel x is an input capture channel, TOV<sub>x</sub> has no effect. Reset clears the TOV<sub>x</sub> bit.

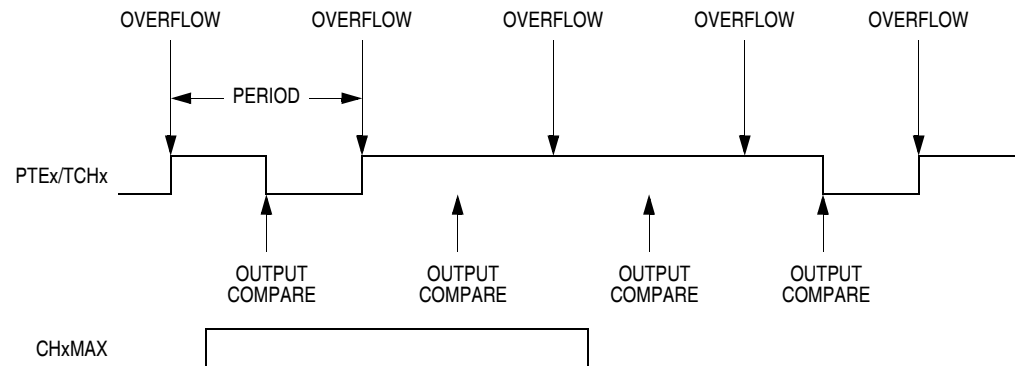
1 = Channel x pin toggles on TIMA counter overflow.

0 = Channel x pin does not toggle on TIMA counter overflow.

**NOTE:** When TOV<sub>x</sub> is set, a TIMA counter overflow takes precedence over a channel x output compare if both occur at the same time.

### CHxMAX — Channel x Maximum Duty Cycle Bit

When the TOVx bit is at logic 0, setting the CHxMAX bit forces the duty cycle of buffered and unbuffered PWM signals to 100%. As [Figure 18-7](#) shows, the CHxMAX bit takes effect in the cycle after it is set or cleared. The output stays at the 100% duty cycle level until the cycle after CHxMAX is cleared.



**Figure 18-7. CHxMAX Latency**

### 18.9.5 TIMA Channel Registers

These read/write registers contain the captured TIMA counter value of the input capture function or the output compare value of the output compare function. The state of the TIMA channel registers after reset is unknown.

In input capture mode ( $MSxB:MSxA = 0:0$ ), reading the high byte of the TIMA channel x registers (TACHxH) inhibits input captures until the low byte (TACHxL) is read.

In output compare mode ( $MSxB:MSxA \neq 0:0$ ), writing to the high byte of the TIMA channel x registers (TACHxH) inhibits output compares until the low byte (TACHxL) is written.

# Timer Interface (TIMA-4)

Register Name and Address: TACH0H — \$0027

	Bit 7	6	5	4	3	2	1	Bit 0
Read:	Bit 15	Bit 14	Bit 13	Bit 12	Bit 11	Bit 10	Bit 9	Bit 8
Write:	Bit 15	Bit 14	Bit 13	Bit 12	Bit 11	Bit 10	Bit 9	Bit 8
Reset:	Indeterminate after Reset							

Register Name and Address: TACH0L — \$0028

	Bit 7	6	5	4	3	2	1	Bit 0
Read:	Bit 7	Bit 6	Bit 5	Bit 4	Bit 3	Bit 2	Bit 1	Bit 0
Write:	Bit 7	Bit 6	Bit 5	Bit 4	Bit 3	Bit 2	Bit 1	Bit 0
Reset:	Indeterminate after Reset							

Register Name and Address: TACH1H — \$002A

	Bit 7	6	5	4	3	2	1	Bit 0
Read:	Bit 15	Bit 14	Bit 13	Bit 12	Bit 11	Bit 10	Bit 9	Bit 8
Write:	Bit 15	Bit 14	Bit 13	Bit 12	Bit 11	Bit 10	Bit 9	Bit 8
Reset:	Indeterminate after Reset							

Register Name and Address: TACH1L — \$002B

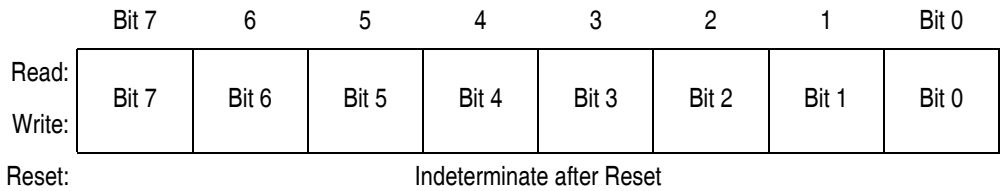
	Bit 7	6	5	4	3	2	1	Bit 0
Read:	Bit 7	Bit 6	Bit 5	Bit 4	Bit 3	Bit 2	Bit 1	Bit 0
Write:	Bit 7	Bit 6	Bit 5	Bit 4	Bit 3	Bit 2	Bit 1	Bit 0
Reset:	Indeterminate after Reset							

Register Name and Address: TACH2H — \$002D

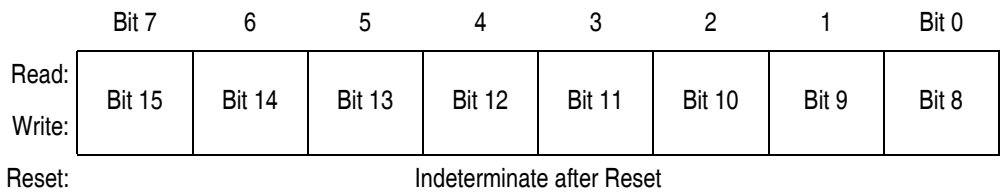
	Bit 7	6	5	4	3	2	1	Bit 0
Read:	Bit 15	Bit 14	Bit 13	Bit 12	Bit 11	Bit 10	Bit 9	Bit 8
Write:	Bit 15	Bit 14	Bit 13	Bit 12	Bit 11	Bit 10	Bit 9	Bit 8
Reset:	Indeterminate after Reset							

**Figure 18-8. TIMA Channel Registers (TACH0H/L–TACH3H/L) (Sheet 1 of 2)**

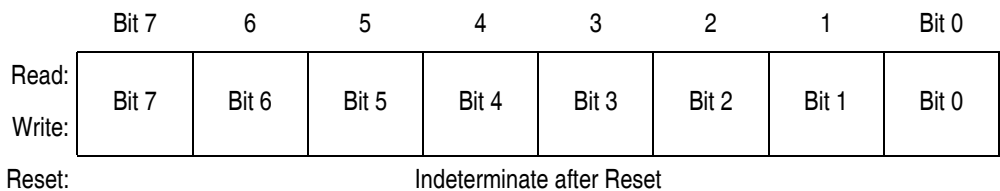
Register Name and Address: TACH2L — \$002E



Register Name and Address: TACH3H — \$0030



Register Name and Address: TACH3L — \$0031



**Figure 18-8. TIMA Channel Registers (TACH0H/L–TACH3H/L) (Sheet 2 of 2)**



## Timer Interface (TIMA-4)

## Section 19. Timer Interface (TIMB)

**NOTE:** This timer is for the *MC68HC08AZ32 emulator* protocol only.

### 19.1 Contents

19.2	Introduction . . . . .	320
19.3	Features . . . . .	320
19.4	Functional Description . . . . .	323
19.4.1	TIMB Counter Prescaler . . . . .	323
19.4.2	Input Capture . . . . .	323
19.4.3	Output Compare . . . . .	325
19.4.3.1	Unbuffered Output Compare . . . . .	325
19.4.3.2	Buffered Output Compare . . . . .	326
19.4.4	Pulse Width Modulation (PWM) . . . . .	326
19.4.4.1	Unbuffered PWM Signal Generation . . . . .	327
19.4.4.2	Buffered PWM Signal Generation . . . . .	328
19.4.4.3	PWM Initialization . . . . .	329
19.5	Interrupts . . . . .	330
19.6	Low-Power Modes . . . . .	331
19.6.1	Wait Mode . . . . .	331
19.6.2	Stop Mode . . . . .	331
19.7	TIMB During Break Interrupts . . . . .	331
19.8	I/O Signals . . . . .	332
19.8.1	TIMB Clock Pin (PTD4/ATD12/TBCLK) . . . . .	332
19.8.2	TIMB Channel I/O Pins (PTF5/TBCH1–PTF4/TBCH0) . . . . .	332
19.9	I/O Registers . . . . .	333
19.9.1	TIMB Status and Control Register . . . . .	333
19.9.2	TIMB Counter Registers . . . . .	336

19.9.3	TIMB Counter Modulo Registers . . . . .	337
19.9.4	TIMB Channel Status and Control Registers . . . . .	338
19.9.5	TIMB Channel Registers . . . . .	342

## 19.2 Introduction

This section describes the timer interface module (TIMB). The TIMB is a 2-channel timer that provides a timing reference with input capture, output compare, and pulse width modulation functions. **Figure 19-1** is a block diagram of the TIMB.

## 19.3 Features

Features of the TIMB include:

- Two Input Capture/Output Compare Channels
  - Rising-Edge, Falling-Edge, or Any-Edge Input Capture Trigger
  - Set, Clear, or Toggle Output Compare Action
- Buffered and Unbuffered Pulse Width Modulation (PWM) Signal Generation
- Programmable TIMB Clock Input
  - 7-Frequency Internal Bus Clock Prescaler Selection
  - External TIMB Clock Input (4-MHz Maximum Frequency)
- Free-Running or Modulo Up-Count Operation
- Toggle Any Channel Pin on Overflow
- TIMB Counter Stop and Reset Bits



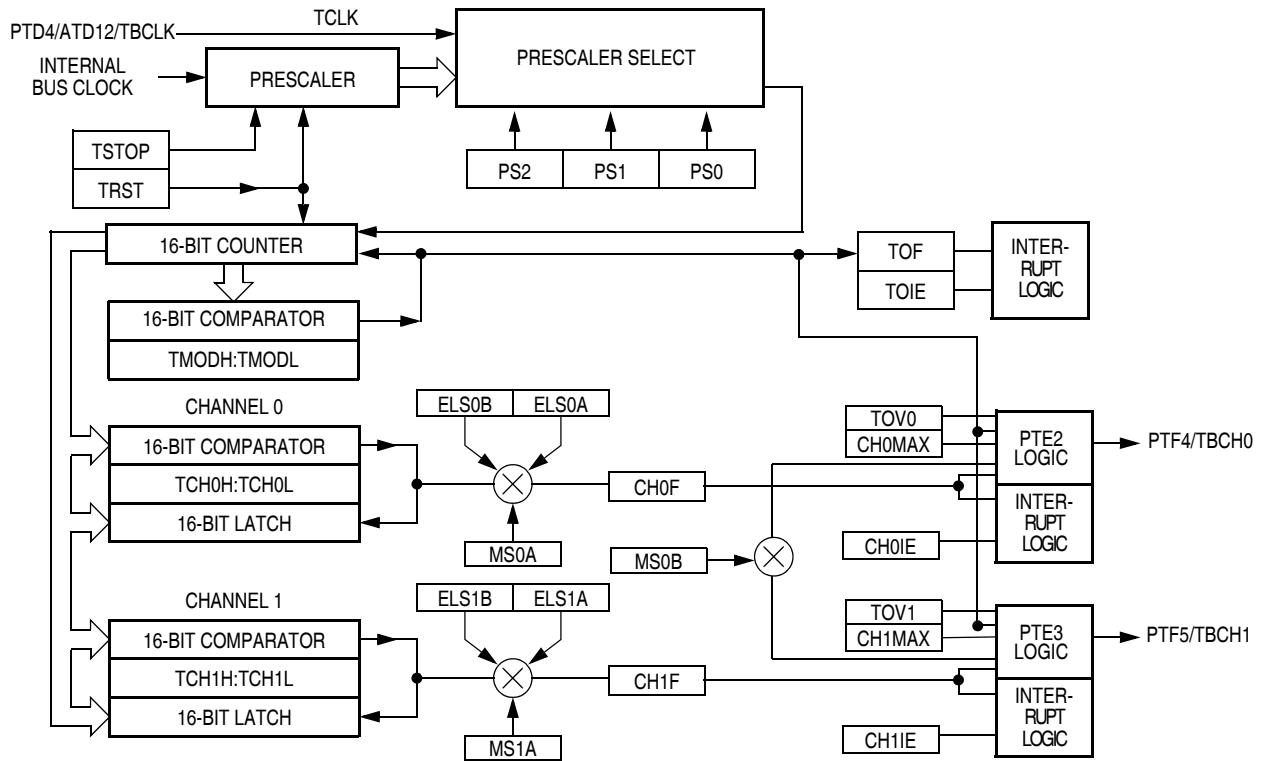


Figure 19-1. TIMB Block Diagram

**Table 19-1. TIMB I/O Register Summary**

Addr.	Register Name	Bit 7	6	5	4	3	2	1	Bit 0	
\$0040	Timer B Status and Control Register (TBSCR)	Read:	TOF	TOIE	TSTOP	0	0	PS2	PS1	PS0
		Write:	0			TRST	R			
		Reset:	0	0	1	0	0	0	0	0
\$0041	Timer B Counter Register High (TBCNTH)	Read:	Bit 15	14	13	12	11	10	9	Bit 8
		Write:	R	R	R	R	R	R	R	R
		Reset:	0	0	0	0	0	0	0	0
\$0042	Timer B Counter Register Low (TBCNTL)	Read:	Bit 7	6	5	4	3	2	1	Bit 0
		Write:	R	R	R	R	R	R	R	R
		Reset:	0	0	0	0	0	0	0	0
\$0043	Timer B Modulo Register High (TBMODH)	Read:	Bit 15	14	13	12	11	10	9	Bit 8
		Write:								
		Reset:	1	1	1	1	1	1	1	1
\$0044	Timer B Modulo Register Low (TBMODL)	Read:	Bit 7	6	5	4	3	2	1	Bit 0
		Write:								
		Reset:	1	1	1	1	1	1	1	1
\$0045	Timer B CH0 Status and Control Register (TBSC0)	Read:	CH0F	CH0IE	MS0B	MS0A	ELS0B	ELS0A	TOV0	CH0MAX
		Write:	0							
		Reset:	0	0	0	0	0	0	0	0
\$0046	Timer B CH0 Register High (TBCH0H)	Read:	Bit 15	14	13	12	11	10	9	Bit 8
		Write:								
		Reset:	Indeterminate after Reset							
\$0047	Timer B CH0 Register Low (TBCH0L)	Read:	Bit 7	6	5	4	3	2	1	Bit 0
		Write:								
		Reset:	Indeterminate after Reset							
\$0048	Timer B CH1 Status and Control Register (TBSC1)	Read:	CH1F	CH1IE	0	MS1A	ELS1B	ELS1A	TOV1	CH1MAX
		Write:	0		R					
		Reset:	0	0	0	0	0	0	0	0
\$0049	Timer B CH1 Register High (TBCH1H)	Read:	Bit 15	14	13	12	11	10	9	Bit 8
		Write:								
		Reset:	Indeterminate after Reset							
\$004A	Timer B CH1 Register Low (TBCH1L)	Read:	Bit 7	6	5	4	3	2	1	Bit 0
		Write:								
		Reset:	Indeterminate after Reset							

## 19.4 Functional Description

**Figure 19-1** shows the TIMB structure. The central component of the TIMB is the 16-bit TIMB counter that can operate as a free-running counter or a modulo up-counter. The TIMB counter provides the timing reference for the input capture and output compare functions. The TIMB counter modulo registers, TBMODH–TBMODL, control the modulo value of the TIMB counter. Software can read the TIMB counter value at any time without affecting the counting sequence.

The two TIMB channels are programmable independently as input capture or output compare channels.

### 19.4.1 TIMB Counter Prescaler

The TIMB clock source can be one of the seven prescaler outputs or the TIMB clock pin, PTD4/ATD12/TBCLK. The prescaler generates seven clock rates from the internal bus clock. The prescaler select bits, PS[2:0], in the TIMB status and control register select the TIMB clock source.

### 19.4.2 Input Capture

An input capture function has three basic parts: edge select logic, an input capture latch, and a 16-bit counter. Two 8-bit registers, which make up the 16-bit input capture register, are used to latch the value of the free-running counter after the corresponding input capture edge detector senses a defined transition. The polarity of the active edge is programmable. The level transition which triggers the counter transfer is defined by the corresponding input edge bits (ELSxB and ELSxA in TBSC0 through TBSC1 control registers with x referring to the active channel number). When an active edge occurs on the pin of an input capture channel, the TIMB latches the contents of the TIMB counter into the TIMB channel registers, TCHxH–TCHxL. Input captures can generate TIMB CPU interrupt requests. Software can determine that an input capture event has occurred by enabling input capture interrupts or by polling the status flag bit.

The result obtained by an input capture will be two more than the value of the free-running counter on the rising edge of the internal bus clock preceding the external transition. This delay is required for internal synchronization.

The free-running counter contents are transferred to the TIMB channel status and control register (TBCHxH–TBCHxL, see [19.9.5 TIMB Channel Registers](#)) on each proper signal transition regardless of whether the TIMB channel flag (CH0F–CH1F in TBSC0–TBSC1 registers) is set or clear. When the status flag is set, a CPU interrupt is generated if enabled. The value of the count latched or “captured” is the time of the event. Because this value is stored in the input capture register 2 bus cycles after the actual event occurs, user software can respond to this event at a later time and determine the actual time of the event. However, this must be done prior to another input capture on the same pin; otherwise, the previous time value will be lost.

By recording the times for successive edges on an incoming signal, software can determine the period and/or pulse width of the signal. To measure a period, two successive edges of the same polarity are captured. To measure a pulse width, two alternate polarity edges are captured. Software should track the overflows at the 16-bit module counter to extend its range.

Another use for the input capture function is to establish a time reference. In this case, an input capture function is used in conjunction with an output compare function. For example, to activate an output signal a specified number of clock cycles after detecting an input event (edge), use the input capture function to record the time at which the edge occurred. A number corresponding to the desired delay is added to this captured value and stored to an output compare register (see [19.9.5 TIMB Channel Registers](#)). Because both input captures and output compares are referenced to the same 16-bit modulo counter, the delay can be controlled to the resolution of the counter independent of software latencies.

Reset does not affect the contents of the input capture channel register (TBCHxH–TBCHxL).

### 19.4.3 Output Compare

With the output compare function, the TIMB can generate a periodic pulse with a programmable polarity, duration, and frequency. When the counter reaches the value in the registers of an output compare channel, the TIMB can set, clear, or toggle the channel pin. Output compares can generate TIMB CPU interrupt requests.

#### 19.4.3.1 Unbuffered Output Compare

Any output compare channel can generate unbuffered output compare pulses as described in [19.4.3 Output Compare](#). The pulses are unbuffered because changing the output compare value requires writing the new value over the old value currently in the TIMB channel registers.

An unsynchronized write to the TIMB channel registers to change an output compare value could cause incorrect operation for up to two counter overflow periods. For example, writing a new value before the counter reaches the old value but after the counter reaches the new value prevents any compare during that counter overflow period. Also, using a TIMB overflow interrupt routine to write a new, smaller output compare value may cause the compare to be missed. The TIMB may pass the new value before it is written.

Use the following methods to synchronize unbuffered changes in the output compare value on channel x:

- When changing to a smaller value, enable channel x output compare interrupts and write the new value in the output compare interrupt routine. The output compare interrupt occurs at the end of the current output compare pulse. The interrupt routine has until the end of the counter overflow period to write the new value.
- When changing to a larger output compare value, enable channel x TIMB overflow interrupts and write the new value in the TIMB overflow interrupt routine. The TIMB overflow interrupt occurs at the end of the current counter overflow period. Writing a larger value in an output compare interrupt routine (at the end of the current pulse) could cause two output compares to occur in the same counter overflow period.

### 19.4.3.2 Buffered Output Compare

Channels 0 and 1 can be linked to form a buffered output compare channel whose output appears on the PTF5/TBCH1 pin. The TIMB channel registers of the linked pair alternately control the output.

Setting the MS0B bit in TIMB channel 0 status and control register (TBSC0) links channel 0 and channel 1. The output compare value in the TIMB channel 0 registers initially controls the output on the PTE2/TACH0 pin. Writing to the TIMB channel 1 registers enables the TIMB channel 1 registers to synchronously control the output after the TIMB overflows. At each subsequent overflow, the TIMB channel registers (0 or 1) that control the output are the ones written to last. TSC0 controls and monitors the buffered output compare function, and TIMB channel 1 status and control register (TBSC1) is unused. While the MS0B bit is set, the channel 1 pin, PTF4/TBCH0, is available as a general-purpose I/O pin.

**NOTE:** *Channels 2 and 3 and channels 4 and 5 can be linked to operate as specified above.*

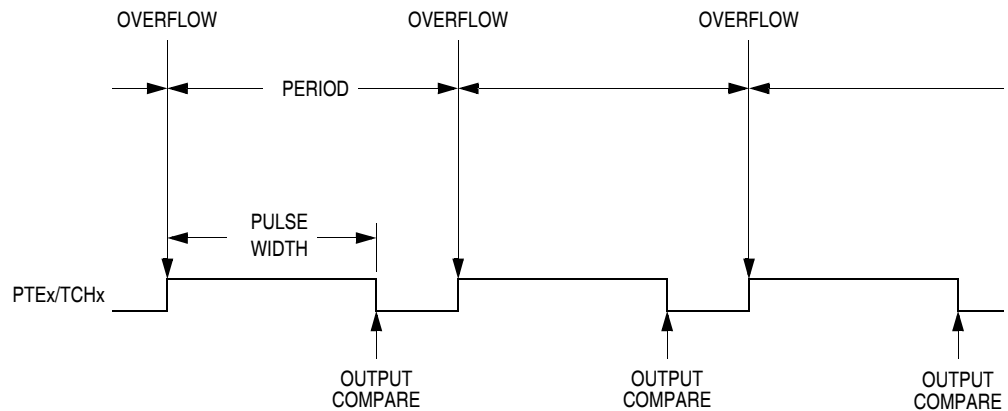
*In buffered output compare operation, do not write new output compare values to the currently active channel registers. Writing to the active channel registers is the same as generating unbuffered output compares.*

### 19.4.4 Pulse Width Modulation (PWM)

By using the toggle-on-overflow feature with an output compare channel, the TIMB can generate a PWM signal. The value in the TIMB counter modulo registers determines the period of the PWM signal. The channel pin toggles when the counter reaches the value in the TIMB counter modulo registers. The time between overflows is the period of the PWM signal.

As **Figure 19-2** shows, the output compare value in the TIMB channel registers determines the pulse width of the PWM signal. The time between overflow and output compare is the pulse width. Program the TIMB to clear the channel pin on output compare if the state of the PWM

pulse is logic 1. Program the TIMB to set the pin if the state of the PWM pulse is logic 0.



**Figure 19-2. PWM Period and Pulse Width**

The value in the TIMB counter modulo registers and the selected prescaler output determines the frequency of the PWM output. The frequency of an 8-bit PWM signal is variable in 256 increments. Writing \$00FF (255) to the TIMB counter modulo registers produces a PWM period of 256 times the internal bus clock period if the prescaler select value is \$000 (see [19.9.1 TIMB Status and Control Register](#)).

The value in the TIMB channel registers determines the pulse width of the PWM output. The pulse width of an 8-bit PWM signal is variable in 256 increments. Writing \$0080 (128) to the TIMB channel registers produces a duty cycle of 128/256 or 50%.

#### 19.4.4.1 Unbuffered PWM Signal Generation

Any output compare channel can generate unbuffered PWM pulses as described in [19.4.4 Pulse Width Modulation \(PWM\)](#). The pulses are unbuffered because changing the pulse width requires writing the new pulse width value over the value currently in the TIMB channel registers.

An unsynchronized write to the TIMB channel registers to change a pulse width value could cause incorrect operation for up to two PWM periods. For example, writing a new value before the counter reaches the old value but after the counter reaches the new value prevents any compare during that PWM period. Also, using a TIMB overflow interrupt

routine to write a new, smaller pulse width value may cause the compare to be missed. The TIMB may pass the new value before it is written to the TIMB channel registers.

Use the following methods to synchronize unbuffered changes in the PWM pulse width on channel x:

- When changing to a shorter pulse width, enable channel x output compare interrupts and write the new value in the output compare interrupt routine. The output compare interrupt occurs at the end of the current pulse. The interrupt routine has until the end of the PWM period to write the new value.
- When changing to a longer pulse width, enable channel x TIMB overflow interrupts and write the new value in the TIMB overflow interrupt routine. The TIMB overflow interrupt occurs at the end of the current PWM period. Writing a larger value in an output compare interrupt routine (at the end of the current pulse) could cause two output compares to occur in the same PWM period.

**NOTE:** *In PWM signal generation, do not program the PWM channel to toggle on output compare. Toggling on output compare prevents reliable 0% duty cycle generation and removes the ability of the channel to self-correct in the event of software error or noise. Toggling on output compare also can cause incorrect PWM signal generation when changing the PWM pulse width to a new, much larger value.*

#### 19.4.4.2 Buffered PWM Signal Generation

Channels 0 and 1 can be linked to form a buffered PWM channel whose output appears on the PTF4/TBCH0 pin. The TIMB channel registers of the linked pair alternately control the pulse width of the output.

Setting the MS0B bit in TIMB channel 0 status and control register (TBSC0) links channel 0 and channel 1. The TIMB channel 0 registers initially control the pulse width on the PTF4/TBCH0 pin. Writing to the TIMB channel 1 registers enables the TIMB channel 1 registers to synchronously control the pulse width at the beginning of the next PWM period. At each subsequent overflow, the TIMB channel registers (0 or 1) that control the pulse width are the ones written to last. TBSC0



controls and monitors the buffered PWM function, and TIMB channel 1 status and control register (TBSC1) is unused. While the MS0B bit is set, the channel 1 pin, PTF5/TBCH1, is available as a general-purpose I/O pin.

**NOTE:** *In buffered PWM signal generation, do not write new pulse width values to the currently active channel registers. Writing to the active channel registers is the same as generating unbuffered PWM signals.*

#### 19.4.4.3 PWM Initialization

To ensure correct operation when generating unbuffered or buffered PWM signals, use the following initialization procedure:

1. In the TIMB status and control register (TBSC):
  - a. Stop the TIMB counter by setting the TIMB stop bit, TSTOP.
  - b. Reset the TIMB counter by setting the TIMB reset bit, TRST.
2. In the TIMB counter modulo registers (TBMODH–TBMODL), write the value for the required PWM period.
3. In the TIMB channel x registers (TBCHxH–TBCHxL), write the value for the required pulse width.
4. In TIMB channel x status and control register (TBSCx):
  - a. Write 0:1 (for unbuffered output compare or PWM signals) or 1:0 (for buffered output compare or PWM signals) to the mode select bits, MSxB–MSxA. (See [Table 19-3](#).)
  - b. Write 1 to the toggle-on-overflow bit, TOVx.
  - c. Write 1:0 (to clear output on compare) or 1:1 (to set output on compare) to the edge/level select bits, ELSxB–ELSxA. The output action on compare must force the output to the complement of the pulse width level. (See [Table 19-3](#).)

**NOTE:** *In PWM signal generation, do not program the PWM channel to toggle on output compare. Toggling on output compare prevents reliable 0% duty cycle generation and removes the ability of the channel to self-correct in the event of software error or noise. Toggling on output*

*compare can also cause incorrect PWM signal generation when changing the PWM pulse width to a new, much larger value.*

5. In the TIMB status control register (TBSC), clear the TIMB stop bit, TSTOP.

Setting MS0B links channels 0 and 1 and configures them for buffered PWM operation. The TIMB channel 0 registers (TBCH0H–TBCH0L) initially control the buffered PWM output. TIMB status control register 0 (TBSC0) controls and monitors the PWM signal from the linked channels. MS0B takes priority over MS0A.

Clearing the toggle-on-overflow bit, TOVx, inhibits output toggles on TIMB overflows. Subsequent output compares try to force the output to a state it is already in and have no effect. The result is a 0% duty cycle output.

Setting the channel x maximum duty cycle bit (CHxMAX) and clearing the TOVx bit generates a 100% duty cycle output. (See [19.9.4 TIMB Channel Status and Control Registers.](#))

## 19.5 Interrupts

The following TIMB sources can generate interrupt requests:

- TIMB overflow flag (TOF) — The TOF bit is set when the TIMB counter value rolls over to \$0000 after matching the value in the TIMB counter modulo registers. The TIMB overflow interrupt enable bit, TOIE, enables TIMB overflow CPU interrupt requests. TOF and TOIE are in the TIMB status and control register.
- TIMB channel flags (CH1F–CH0F) — The CHxF bit is set when an input capture or output compare occurs on channel x. Channel x TIMB CPU interrupt requests are controlled by the channel x interrupt enable bit, CHxIE.

## 19.6 Low-Power Modes

The WAIT and STOP instructions put the MCU in low-power standby modes.

### 19.6.1 Wait Mode

The TIMB remains active after the execution of a WAIT instruction. In wait mode, the TIMB registers are not accessible by the CPU. Any enabled CPU interrupt request from the TIMB can bring the MCU out of wait mode.

If TIMB functions are not required during wait mode, reduce power consumption by stopping the TIMB before executing the WAIT instruction.

### 19.6.2 Stop Mode

The TIMB is inactive after the execution of a STOP instruction. The STOP instruction does not affect register conditions or the state of the TIMB counter. TIMB operation resumes when the MCU exits stop mode.

## 19.7 TIMB During Break Interrupts

A break interrupt stops the TIMB counter and inhibits input captures.

The system integration module (SIM) controls whether status bits in other modules can be cleared during the break state. The BCFE bit in the SIM break flag control register (SBFCR) enables software to clear status bits during the break state. (See [7.8.3 SIM Break Flag Control Register](#).)

To allow software to clear status bits during a break interrupt, write a logic 1 to the BCFE bit. If a status bit is cleared during the break state, it remains cleared when the MCU exits the break state.

To protect status bits during the break state, write a logic 0 to the BCFE bit. With BCFE at logic 0 (its default state), software can read and write

I/O registers during the break state without affecting status bits. Some status bits have a 2-step read/write clearing procedure. If software does the first step on such a bit before the break, the bit cannot change during the break state as long as BCFE is at logic 0. After the break, doing the second step clears the status bit.

### 19.8 I/O Signals

Port D shares one of its pins with the TIMB. Port F shares two of its pins with the TIMB. PTD4/ATD12/TBCLK is an external clock input to the TIMB prescaler. The two TIMB channel I/O pins are PTF4/TBCH0 and PTF5/TBCH1.

#### 19.8.1 TIMB Clock Pin (PTD4/ATD12/TBCLK)

PTD4/ATD12/TBCLK is an external clock input that can be the clock source for the TIMB counter instead of the prescaled internal bus clock. Select the PTD4/ATD12/TBCLK input by writing logic 1s to the three prescaler select bits, PS[2:0]. (See [19.9.1 TIMB Status and Control Register](#).) The minimum TCLK pulse width,  $TCLK_{LMIN}$  or  $TCLK_{HMIN}$ , is:

$$\frac{1}{\text{bus frequency}} + t_{SU}$$

The maximum TCLK frequency is the least: 4 MHz or bus frequency  $\div$  2.

PTD4/ATD12/TBCLK is available as a general-purpose I/O pin or ADC channel when not used as the TIMB clock input. When the PTD6/ATD14/TACLK pin is the TIMB clock input, it is an input regardless of the state of the DDRD6 bit in data direction register D.

#### 19.8.2 TIMB Channel I/O Pins (PTF5/TBCH1–PTF4/TBCH0)

Each channel I/O pin is programmable independently as an input capture pin or an output compare pin. PTF4/TBCH0 and PTF5/TBCH1 can be configured as buffered output compare or buffered PWM pins.

## 19.9 I/O Registers

These I/O registers control and monitor TIMB operation:

- TIMB status and control register (TBSC)
- TIMB control registers (TBCNTH–TBCNTL)
- TIMB counter modulo registers (TBMODH–TBMODL)
- TIMB channel status and control registers (TBSC0 and TBSC1)
- TIMB channel registers (TBCH0H–TBCH0L, TBCH1H–TBCH1L)

### 19.9.1 TIMB Status and Control Register

The TIMB status and control register:

- Enables TIMB overflow interrupts
- Flags TIMB overflows
- Stops the TIMB counter
- Resets the TIMB counter
- Prescales the TIMB counter clock

Address: \$0040

	Bit 7	6	5	4	3	2	1	Bit 0
Read:	TOF	TOIE	TSTOP	0	0	PS2	PS1	PS0
Write:	0			TRST	R			
Reset:	0	0	1	0	0	0	0	0

R = Reserved

**Figure 19-3. TIMB Status and Control Register (TBSC)**

### TOF — TIMB Overflow Flag Bit

This read/write flag is set when the TIMB counter resets to \$0000 after reaching the modulo value programmed in the TIMB counter modulo registers. Clear TOF by reading the TIMB status and control register when TOF is set and then writing a logic 0 to TOF. If another TIMB overflow occurs before the clearing sequence is complete, then writing logic 0 to TOF has no effect. Therefore, a TOF interrupt request cannot be lost due to inadvertent clearing of TOF. Reset clears the TOF bit. Writing a logic 1 to TOF has no effect.

- 1 = TIMB counter has reached modulo value
- 0 = TIMB counter has not reached modulo value

### TOIE — TIMB Overflow Interrupt Enable Bit

This read/write bit enables TIMB overflow interrupts when the TOF bit becomes set. Reset clears the TOIE bit.

- 1 = TIMB overflow interrupts enabled
- 0 = TIMB overflow interrupts disabled

### TSTOP — TIMB Stop Bit

This read/write bit stops the TIMB counter. Counting resumes when TSTOP is cleared. Reset sets the TSTOP bit, stopping the TIMB counter until software clears the TSTOP bit.

- 1 = TIMB counter stopped
- 0 = TIMB counter active

**NOTE:** Do not set the TSTOP bit before entering wait mode if the TIMB is required to exit wait mode. Also, when the TSTOP bit is set and the timer is configured for input capture operation, input captures are inhibited until TSTOP is cleared.

**TRST — TIMB Reset Bit**

Setting this write-only bit resets the TIMB counter and the TIMB prescaler. Setting TRST has no effect on any other registers. Counting resumes from \$0000. TRST is cleared automatically after the TIMB counter is reset and always reads as logic 0. Reset clears the TRST bit.

- 1 = Prescaler and TIMB counter cleared
- 0 = No effect

**NOTE:** *Setting the TSTOP and TRST bits simultaneously stops the TIMB counter at a value of \$0000.*

**PS[2:0] — Prescaler Select Bits**

These read/write bits select either the PTD4/ATD12/TBCLK pin or one of the seven prescaler outputs as the input to the TIMB counter as [Table 19-2](#) shows. Reset clears the PS[2:0] bits.

**Table 19-2. Prescaler Selection**

PS[2:0]	TIMB Clock Source
000	Internal Bus Clock ÷ 1
001	Internal Bus Clock ÷ 2
010	Internal Bus Clock ÷ 4
011	Internal Bus Clock ÷ 8
100	Internal Bus Clock ÷ 16
101	Internal Bus Clock ÷ 32
110	Internal Bus Clock ÷ 64
111	PTD6/ATD14/TACLK

## 19.9.2 TIMB Counter Registers

The two read-only TIMB counter registers contain the high and low bytes of the value in the TIMB counter. Reading the high byte (TBCNTH) latches the contents of the low byte (TBCNTL) into a buffer. Subsequent reads of TBCNTH do not affect the latched TBCNTL value until TBCNTL is read. Reset clears the TIMB counter registers. Setting the TIMB reset bit (TRST) also clears the TIMB counter registers.

**NOTE:** *If TBCNTH is read during a break interrupt, be sure to unlatch TBCNTL by reading TBCNTL before exiting the break interrupt. Otherwise, TBCNTL retains the value latched during the break.*

Register Name and Address: TBCNTH — \$0041

	Bit 7	6	5	4	3	2	1	Bit 0
Read:	BIT 15	BIT 14	BIT 13	BIT 12	BIT 11	BIT 10	BIT 9	BIT 8
Write:	R	R	R	R	R	R	R	R
Reset:	0	0	0	0	0	0	0	0

Register Name and Address: TBCNTL — \$0042

	Bit 7	6	5	4	3	2	1	Bit 0
Read:	BIT 7	BIT 6	BIT 5	BIT 4	BIT 3	BIT 2	BIT 1	BIT 0
Write:	R	R	R	R	R	R	R	R
Reset:	0	0	0	0	0	0	0	0

R
---

 = Reserved

**Figure 19-4. TIMB Counter Registers (TBCNTH and TBCNTL)**



19.9.3 TIMB Counter Modulo Registers

The read/write TIMB modulo registers contain the modulo value for the TIMB counter. When the TIMB counter reaches the modulo value, the overflow flag (TOF) becomes set, and the TIMB counter resumes counting from \$0000 at the next clock. Writing to the high byte (TMODH) inhibits the TOF bit and overflow interrupts until the low byte (TMODL) is written. Reset sets the TIMB counter modulo registers.

Register Name and Address: TBMODH — \$0043

	Bit 7	6	5	4	3	2	1	Bit 0
Read:	BIT 15	BIT 14	BIT 13	BIT 12	BIT 11	BIT 10	BIT 9	BIT 8
Write:								
Reset:	1	1	1	1	1	1	1	1

Register Name and Address: TBMODL — \$0044

	Bit 7	6	5	4	3	2	1	Bit 0
Read:	BIT 7	BIT 6	BIT 5	BIT 4	BIT 3	BIT 2	BIT 1	BIT 0
Write:								
Reset:	1	1	1	1	1	1	1	1

Figure 19-5. TIMB Counter Modulo Registers (TMODH and TMODL)

**NOTE:** *Reset the TIMB counter before writing to the TIMB counter modulo registers.*

## 19.9.4 TIMB Channel Status and Control Registers

Each of the TIMB channel status and control registers:

- Flags input captures and output compares
- Enables input capture and output compare interrupts
- Selects input capture, output compare, or PWM operation
- Selects high, low, or toggling output on output compare
- Selects rising edge, falling edge, or any edge as the active input capture trigger
- Selects output toggling on TIMB overflow
- Selects 100% PWM duty cycle
- Selects buffered or unbuffered output compare/PWM operation

Register Name and Address: TBSC0 — \$0045

	Bit 7	6	5	4	3	2	1	Bit 0
Read:	CH0F	CH0IE	MS0B	MS0A	ELS0B	ELS0A	TOV0	CH0MAX
Write:	0							
Reset:	0	0	0	0	0	0	0	0

Register Name and Address: TBSC1 — \$0048

	Bit 7	6	5	4	3	2	1	Bit 0
Read:	CH1F	CH1IE	0	MS1A	ELS1B	ELS1A	TOV1	CH1MAX
Write:	0		R					
Reset:	0	0	0	0	0	0	0	0

R = Reserved

**Figure 19-6. TIMB Channel Status and Control Registers (TBSC0–TBSC1)**

### CHxF — Channel x Flag Bit

When channel x is an input capture channel, this read/write bit is set when an active edge occurs on the channel x pin. When channel x is an output compare channel, CHxF is set when the value in the TIMB counter registers matches the value in the TIMB channel x registers.

When CHxIE = 0, clear CHxF by reading TIMB channel x status and control register with CHxF set, and then writing a logic 0 to CHxF. If another interrupt request occurs before the clearing sequence is complete, then writing logic 0 to CHxF has no effect. Therefore, an interrupt request cannot be lost due to inadvertent clearing of CHxF.

Reset clears the CHxF bit. Writing a logic 1 to CHxF has no effect.

1 = Input capture or output compare on channel x

0 = No input capture or output compare on channel x

### CHxIE — Channel x Interrupt Enable Bit

This read/write bit enables TIMB CPU interrupts on channel x.

Reset clears the CHxIE bit.

1 = Channel x CPU interrupt requests enabled

0 = Channel x CPU interrupt requests disabled

### MSxB — Mode Select Bit B

This read/write bit selects buffered output compare/PWM operation. MSxB exists only in the TIMB channel 0.

Setting MS0B disables the channel 1 status and control register and reverts TBCH1 to general-purpose I/O.

Reset clears the MSxB bit.

1 = Buffered output compare/PWM operation enabled

0 = Buffered output compare/PWM operation disabled

## MSxA — Mode Select Bit A

When ELSxB:A  $\neq$  00, this read/write bit selects either input capture operation or unbuffered output compare/PWM operation. (See [Table 19-3](#).)

- 1 = Unbuffered output compare/PWM operation
- 0 = Input capture operation

When ELSxB:A = 00, this read/write bit selects the initial output level of the TCHx pin once PWM, input capture, or output compare operation is enabled. (See [Table 19-3](#).) Reset clears the MSxA bit.

- 1 = Initial output level low
- 0 = Initial output level high

**NOTE:** *Before changing a channel function by writing to the MSxB or MSxA bit, set the TSTOP and TRST bits in the TIMB status and control register (TBSC).*

## ELSxB and ELSxA — Edge/Level Select Bits

When channel x is an input capture channel, these read/write bits control the active edge-sensing logic on channel x.

When channel x is an output compare channel, ELSxB and ELSxA control the channel x output behavior when an output compare occurs.

When ELSxB and ELSxA are both clear, channel x is not connected to port E or port F, and pin PTE<sub>x</sub>/TBCH<sub>x</sub> or pin PTF<sub>x</sub>/TBCH<sub>x</sub> is available as a general-purpose I/O pin. However, channel x is at a state determined by these bits and becomes transparent to the respective pin when PWM, input capture, or output compare mode is enabled. [Table 19-3](#) shows how ELSxB and ELSxA work. Reset clears the ELSxB and ELSxA bits.

**Table 19-3. Mode, Edge, and Level Selection**

MSxB:MSxA	ELSxB:ELSxA	Mode	Configuration
X0	00	Output Preset	Pin under Port Control; Initialize Timer Output Level High
X1	00		Pin under Port Control; Initialize Timer Output Level Low
00	01	Input Capture	Capture on Rising Edge Only
00	10		Capture on Falling Edge Only
00	11		Capture on Rising or Falling Edge
01	01	Output Compare or PWM	Toggle Output on Compare
01	10		Clear Output on Compare
01	11		Set Output on Compare
1X	01	Buffered Output Compare or Buffered PWM	Toggle Output on Compare
1X	10		Clear Output on Compare
1X	11		Set Output on Compare

**NOTE:** Before enabling a TIMB channel register for input capture operation, make sure that the PTE<sub>x</sub>/TBCH<sub>x</sub> pin or PTF<sub>x</sub>/TBCH<sub>x</sub> pin is stable for at least two bus clocks.

#### TOV<sub>x</sub> — Toggle-On-Overflow Bit

When channel x is an output compare channel, this read/write bit controls the behavior of the channel x output when the TIMB counter overflows. When channel x is an input capture channel, TOV<sub>x</sub> has no effect. Reset clears the TOV<sub>x</sub> bit.

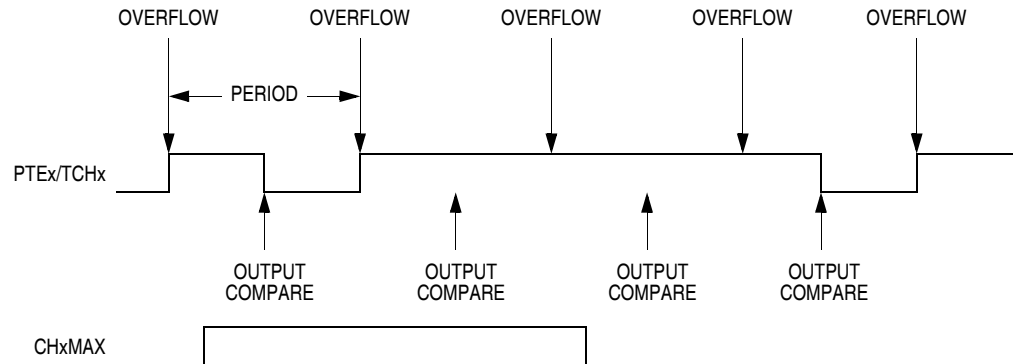
1 = Channel x pin toggles on TIMB counter overflow.

0 = Channel x pin does not toggle on TIMB counter overflow.

**NOTE:** When TOV<sub>x</sub> is set, a TIMB counter overflow takes precedence over a channel x output compare if both occur at the same time.

## CHxMAX — Channel x Maximum Duty Cycle Bit

When the TOVx bit is at logic 0, setting the CHxMAX bit forces the duty cycle of buffered and unbuffered PWM signals to 100%. As **Figure 19-7** shows, the CHxMAX bit takes effect in the cycle after it is set or cleared. The output stays at the 100% duty cycle level until the cycle after CHxMAX is cleared.



**Figure 19-7. CHxMAX Latency**

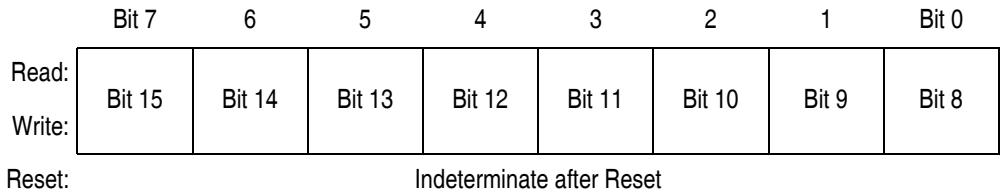
### 19.9.5 TIMB Channel Registers

These read/write registers contain the captured TIMB counter value of the input capture function or the output compare value of the output compare function. The state of the TIMB channel registers after reset is unknown.

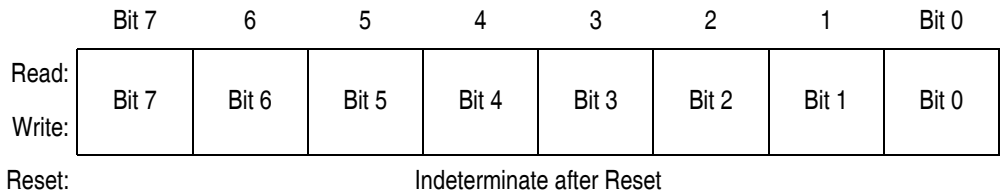
In input capture mode ( $MSxB-MSxA = 0:0$ ), reading the high byte of the TIMB channel x registers (TBCHxH) inhibits input captures until the low byte (TBCHxL) is read.

In output compare mode ( $MSxB-MSxA \neq 0:0$ ), writing to the high byte of the TIMB channel x registers (TBCHxH) inhibits output compares until the low byte (TBCHxL) is written.

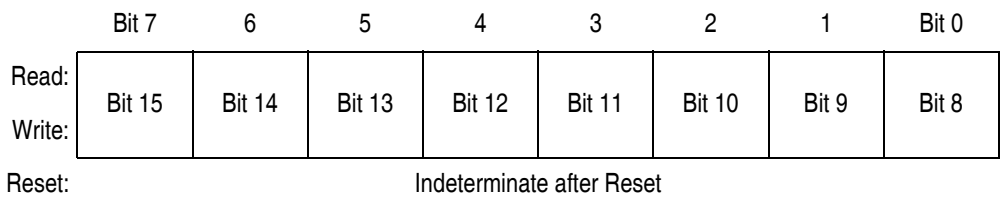
Register Name and Address: TBCH0H — \$0046



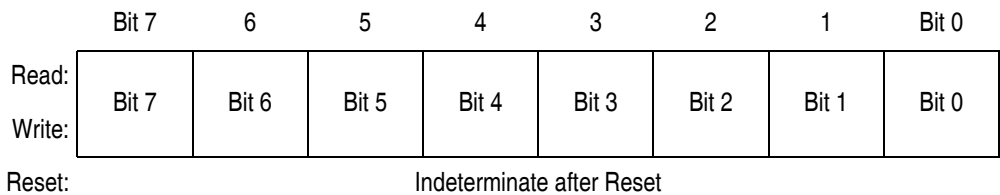
Register Name and Address: TBCH0L — \$0047



Register Name and Address: TBCH1H — \$0049



Register Name and Address: TBCH1L — \$004A



**Figure 19-8. TIMB Channel Registers (TBCH0H/L–TBCH1H/L)**





## Section 20. Modulo Timer (TIM)

### 20.1 Contents

20.2	Introduction . . . . .	345
20.3	Features . . . . .	346
20.4	Functional Description . . . . .	346
20.5	TIM Counter Prescaler . . . . .	348
20.6	Low-Power Modes . . . . .	348
20.6.1	Wait Mode . . . . .	348
20.6.2	Stop Mode . . . . .	348
20.7	TIM During Break Interrupts . . . . .	349
20.8	I/O Registers . . . . .	349
20.8.1	TIM Status and Control Register . . . . .	350
20.8.2	TIM Counter Registers . . . . .	352
20.8.3	TIM Counter Modulo Registers . . . . .	353

### 20.2 Introduction

This section describes the modulo timer which is a periodic interrupt timer whose counter is clocked internally via software programmable options. **Figure 20-1** is a block diagram of the TIM.

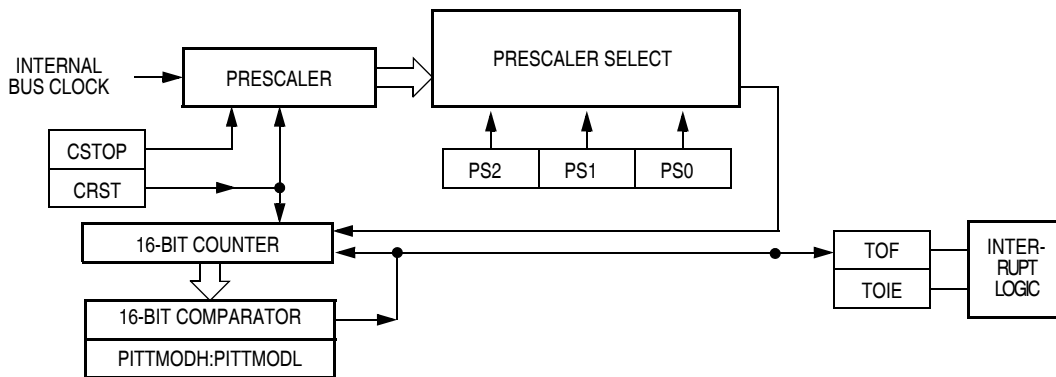
## 20.3 Features

Features of the TIM include:

- Programmable TIM Clock Input
- Free-Running or Modulo Up-Count Operation
- TIM Counter Stop and Reset Bits

## 20.4 Functional Description

**Figure 20-1** shows the structure of the TIM. The central component of the TIM is the 16-bit TIM counter that can operate as a free-running counter or a modulo up-counter. The counter provides the timing reference for the interrupt. The TIM counter modulo registers, TMODH–TMODL, control the modulo value of the counter. Software can read the counter value at any time without affecting the counting sequence.


**Figure 20-1. TIM Block Diagram**
**Table 20-1. TIM I/O Register Summary**

Register Name	Bit 7	6	5	4	3	2	1	Bit 0
TIM Status and Control Register (TSC)	Read:	TOF			0	0		
	Write:	0	TOIE	TSTOP	TRST		PS2	PS1
	Reset:	0	0	1	0	0	0	0
TIM Counter Register High (TCNTH)	Read:	Bit 15	14	13	12	11	10	9
	Write:							
	Reset:	0	0	0	0	0	0	0
TIM Counter Register Low (TCNTL)	Read:	Bit 7	6	5	4	3	2	1
	Write:							
	Reset:	0	0	0	0	0	0	0
TIM Counter Modulo Register High (TMODH)	Read:	Bit 15	14	13	12	11	10	9
	Write:							
	Reset:	1	1	1	1	1	1	1
TIM Counter Modulo Register Low (TMODL)	Read:	Bit 7	6	5	4	3	2	1
	Write:							
	Reset:	1	1	1	1	1	1	1

=Unimplemented

**Table 20-2. TIM I/O Register Address Summary**

Register	TSC	TCNTH	TCNTL	TMODH	TMODL
Address	\$004B	\$004C	\$004D	\$004E	\$004F

## 20.5 TIM Counter Prescaler

The clock source can be one of the seven prescaler outputs. The prescaler generates seven clock rates from the internal bus clock. The prescaler select bits, PS[2:0], in the status and control register select the TIM clock source.

The value in the TIM counter modulo registers and the selected prescaler output determines the frequency of the periodic interrupt. The TIM overflow flag (TOF) is set when the TIM counter value rolls over to \$0000 after matching the value in the TIM counter modulo registers. The TIM interrupt enable bit, TOIE, enables TIM overflow CPU interrupt requests. TOF and TOIE are in the TIM status and control register.

## 20.6 Low-Power Modes

The WAIT and STOP instructions put the MCU in low-power standby modes.

### 20.6.1 Wait Mode

The TIM remains active after the execution of a WAIT instruction. In wait mode the TIM registers are not accessible by the CPU. Any enabled CPU interrupt request from the TIM can bring the MCU out of wait mode.

If TIM functions are not required during wait mode, reduce power consumption by stopping the TIM before executing the WAIT instruction.

### 20.6.2 Stop Mode

The TIM is inactive after the execution of a STOP instruction. The STOP instruction does not affect register conditions or the state of the TIM counter. TIM operation resumes when the MCU exits stop mode after an external interrupt.

## 20.7 TIM During Break Interrupts

A break interrupt stops the TIM counter.

The system integration module (SIM) controls whether status bits in other modules can be cleared during the break state. The BCFE bit in the SIM break flag control register (SBFCR) enables software to clear status bits during the break state. (See [7.8.3 SIM Break Flag Control Register](#).)

To allow software to clear status bits during a break interrupt, write a logic 1 to the BCFE bit. If a status bit is cleared during the break state, it remains cleared when the MCU exits the break state.

To protect status bits during the break state, write a logic 0 to the BCFE bit. With BCFE at logic 0 (its default state), software can read and write I/O registers during the break state without affecting status bits. Some status bits have a 2-step read/write clearing procedure. If software does the first step on such a bit before the break, the bit cannot change during the break state as long as BCFE is at logic 0. After the break, doing the second step clears the status bit.

## 20.8 I/O Registers

The following I/O registers control and monitor operation of the TIM:

- TIM status and control register (TSC)
- TIM counter registers (TCNTH–TCNTL)
- TIM counter modulo registers (TMODH–TMODL)


## 20.8.1 TIM Status and Control Register

The TIM status and control register:

- Enables TIM interrupt
- Flags TIM overflows
- Stops the TIM counter
- Resets the TIM counter
- Prescales the TIM counter clock

Address: \$004B

	Bit 7	6	5	4	3	2	1	Bit 0
Read:	TOF	TOIE	TSTOP	0	0	PS2	PS1	PS0
Write:	0			TRST				
Reset:	0	0	1	0	0	0	0	0

 = Unimplemented

**Figure 20-2. TIM Status and Control Register (TSC)**

### TOF — TIM Overflow Flag Bit

This read/write flag is set when the TIM counter resets to \$0000 after reaching the modulo value programmed in the TIM counter modulo registers. Clear TOF by reading the TIM status and control register when TOF is set and then writing a logic 0 to TOF. If another TIM overflow occurs before the clearing sequence is complete, then writing logic 0 to TOF has no effect. Therefore, a TOF interrupt request cannot be lost due to inadvertent clearing of TOF. Reset clears the TOF bit. Writing a logic 1 to TOF has no effect.

1 = TIM counter has reached modulo value

0 = TIM counter has not reached modulo value

### TOIE — TIM Overflow Interrupt Enable Bit

This read/write bit enables TIM overflow interrupts when the TOF bit becomes set. Reset clears the TOIE bit.

1 = TIM overflow interrupts enabled

0 = TIM overflow interrupts disabled

### TSTOP — TIM Stop Bit

This read/write bit stops the TIM counter. Counting resumes when TSTOP is cleared. Reset sets the TSTOP bit, stopping the TIM counter until software clears the TSTOP bit.

- 1 = TIM counter stopped
- 0 = TIM counter active

**NOTE:** *Do not set the TSTOP bit before entering wait mode if the TIM is required to exit wait mode.*

### TRST — TIM Reset Bit

Setting this write-only bit resets the TIM counter and the TIM prescaler. Setting TRST has no effect on any other registers. Counting resumes from \$0000. TRST is cleared automatically after the TIM counter is reset and always reads as logic zero. Reset clears the TRST bit.

- 1 = Prescaler and TIM counter cleared
- 0 = No effect

**NOTE:** *Setting the TSTOP and TRST bits simultaneously stops the TIM counter at a value of \$0000.*

### PS[2:0] — Prescaler Select Bits

These read/write bits select one of the seven prescaler outputs as the input to the TIM counter as [Table 20-3](#) shows. Reset clears the PS[2:0] bits.

**Table 20-3. Prescaler Selection**

PS[2:0]	TIM Clock Source
000	Internal Bus Clock ÷ 1
001	Internal Bus Clock ÷ 2
010	Internal Bus Clock ÷ 4
011	Internal Bus Clock ÷ 8
100	Internal Bus Clock ÷ 16
101	Internal Bus Clock ÷ 32
110	Internal Bus Clock ÷ 64
111	Internal Bus Clock ÷ 64

## 20.8.2 TIM Counter Registers

The two read-only TIM counter registers contain the high and low bytes of the value in the TIM counter. Reading the high byte (TCNTH) latches the contents of the low byte (TCNTL) into a buffer. Subsequent reads of TCNTH do not affect the latched TCNTL value until TCNTL is read. Reset clears the TIM counter registers. Setting the TIM reset bit (TRST) also clears the TIM counter registers.


**NOTE:** *If you read TCNTH during a break interrupt, be sure to unlatch TCNTL by reading TCNTL before exiting the break interrupt. Otherwise, TCNTL retains the value latched during the break.*

Address: \$004C

	Bit 7	6	5	4	3	2	1	Bit 0
Read:	Bit 15	14	13	12	11	10	9	Bit 8
Write:								
Reset:	0	0	0	0	0	0	0	0

Address: \$004D

	Bit 7	6	5	4	3	2	1	Bit 0
Read:	Bit 15	14	13	12	11	10	9	Bit 8
Write:								
Reset:	0	0	0	0	0	0	0	0

 = Unimplemented

**Figure 20-3. TIM Counter Registers (TCNTH–TCNTL)**



### 20.8.3 TIM Counter Modulo Registers

The read/write TIM modulo registers contain the modulo value for the TIM counter. When the TIM counter reaches the modulo value, the overflow flag (TOF) becomes set, and the TIM counter resumes counting from \$0000 at the next clock. Writing to the high byte (TMODH) inhibits the TOF bit and overflow interrupts until the low byte (TMODL) is written. Reset sets the TIM counter modulo registers.

Register and Address: TMODH — \$004E

	Bit 7	6	5	4	3	2	1	Bit 0
Read:	Bit 15	14	13	12	11	10	9	Bit 8
Write:								
Reset:	1	1	1	1	1	1	1	1

Register and Address: TMODL — \$004F

	Bit 7	6	5	4	3	2	1	Bit 0
Read:	Bit 7	6	5	4	3	2	1	Bit 0
Write:								
Reset:	1	1	1	1	1	1	1	1

**Figure 20-4. TIM Counter Modulo Registers (TMODH–TMODL)**

**NOTE:** Reset the TIM counter before writing to the TIM counter modulo registers.



## Section 21. Analog-to-Digital Converter (ADC-8)

**NOTE:** *This analog-to-digital converter is for the **CAN (64-pin QFP)** protocol only.*

### 21.1 Contents

21.2	Introduction . . . . .	356
21.3	Features . . . . .	356
21.4	Functional Description . . . . .	356
21.4.1	ADC Port I/O Pins . . . . .	358
21.4.2	Voltage Conversion . . . . .	358
21.4.3	Conversion Time . . . . .	359
21.4.4	Continuous Conversion . . . . .	359
21.4.5	Accuracy and Precision . . . . .	359
21.5	Interrupts . . . . .	360
21.6	Low-Power Modes . . . . .	360
21.6.1	Wait Mode . . . . .	360
21.6.2	Stop Mode . . . . .	360
21.7	I/O Signals . . . . .	361
21.7.1	ADC Analog Power Pin ( $V_{DDAREF}$ )/ADC Voltage Reference Pin ( $V_{REFH}$ ) . . . . .	361
21.7.2	ADC Analog Ground Pin ( $AV_{SS}$ )/ADC Voltage Reference Low Pin ( $V_{REFL}$ ) . . . . .	361
21.7.3	ADC Voltage In ( $ADCV_{IN}$ ) . . . . .	361
21.8	I/O Registers . . . . .	362
21.8.1	ADC Status and Control Register . . . . .	362
21.8.2	ADC Data Register . . . . .	365
21.8.3	ADC Input Clock Register . . . . .	365

## 21.2 Introduction

This section describes the analog-to-digital converter (ADC-8). The ADC is an 8-bit analog-to-digital converter.

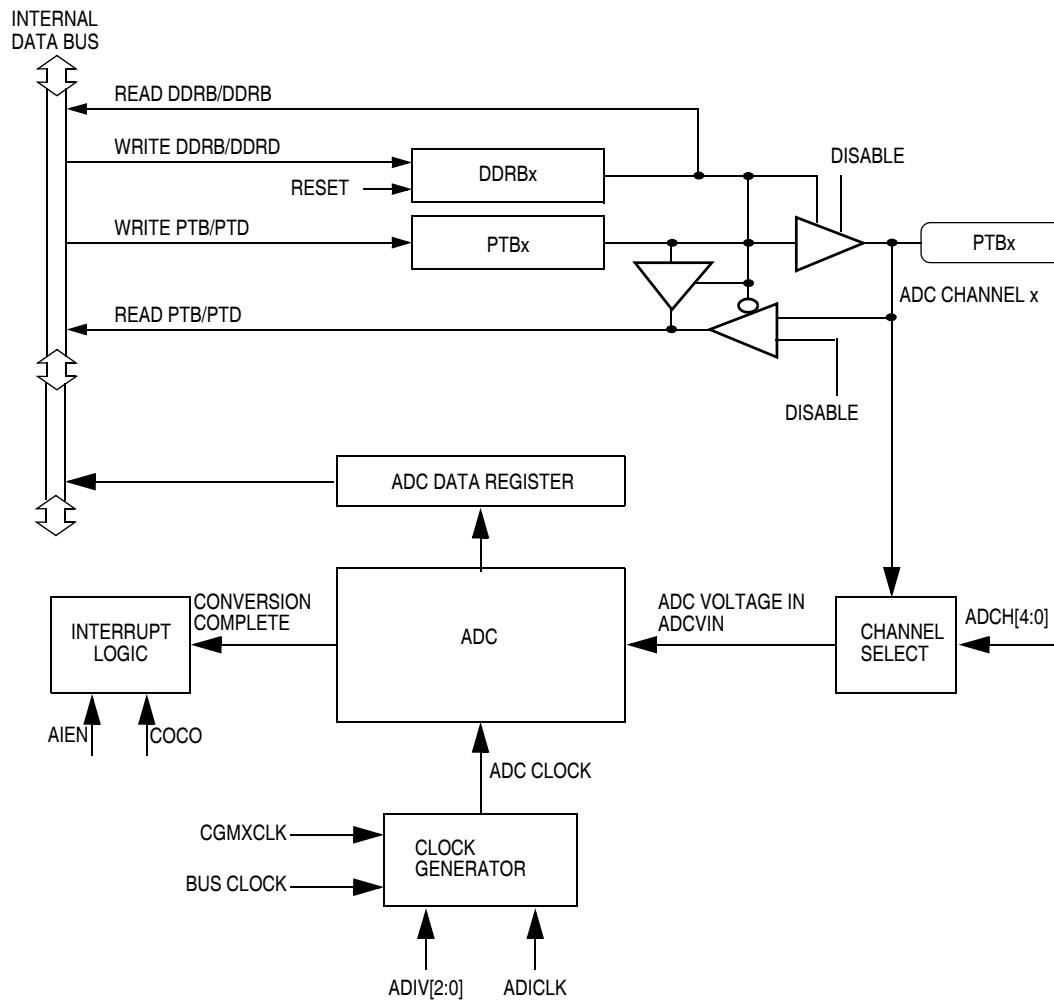
## 21.3 Features

Features of the ADC module include:

- Eight Channels with Multiplexed Input
- Linear Successive Approximation
- 8-Bit Resolution
- Single or Continuous Conversion
- Conversion Complete Flag or Conversion Complete Interrupt
- Selectable ADC Clock

## 21.4 Functional Description

Eight ADC channels are available for sampling external sources at pins PTB7/ATD7–PTB0/ATD0. An analog multiplexer allows the single ADC converter to select one of eight ADC channels as ADC voltage in (ADCVIN). ADCVIN is converted by the successive approximation register-based counters. When the conversion is completed, the ADC places the result in the ADC data register and sets a flag or generates an interrupt. (See [Figure 21-1](#).)



**Figure 21-1. ADC Block Diagram**

### 21.4.1 ADC Port I/O Pins

PTB7/ATD7–PTB0/ATD0 are general-purpose I/O pins that are shared with the ADC channels.

The channel select bits define which ADC channel/port pin will be used as the input signal. The ADC overrides the port I/O logic by forcing that pin as input to the ADC. The remaining ADC channels/port pins are controlled by the port I/O logic and can be used as general-purpose I/O. Writes to the port register or DDR will not have any affect on the port pin that is selected by the ADC. Read of a port pin which is in use by the ADC will return a logic 0 if the corresponding DDR bit is at logic 0. If the DDR bit is at logic 1, the value in the port data latch is read.

### 21.4.2 Voltage Conversion

When the input voltage to the ADC equals  $V_{REFH}$  (see [29.7 ADC Characteristics](#)), the ADC converts the signal to \$FF (full scale). If the input voltage equals  $V_{SSA}$ , the ADC converts it to \$00. Input voltages between  $V_{REFH}$  and  $V_{SSA}$  are a straight-line linear conversion. All other input voltages will result in \$FF if greater than  $V_{REFH}$  and \$00 if less than  $V_{SSA}$ .

**NOTE:** *Input voltage should not exceed the analog supply voltages.*

### 21.4.3 Conversion Time

Conversion starts after a write to the ADSCR (ADC status control register, \$0038) and requires between 16 and 17 ADC clock cycles to complete. Conversion time in terms of the number of bus cycles is a function of ADICLK select, CGMXCLK frequency, bus frequency, and ADIV prescaler bits. For example, with a CGMXCLK frequency of 4 MHz, bus frequency of 8 MHz, and fixed ADC clock frequency of 1 MHz, one conversion will take between 16 and 17  $\mu$ s and there will be between 128 and 136 bus cycles between each conversion. Sample rate is approximately 60 kHz.

Refer to [29.7 ADC Characteristics](#).

$$\text{Conversion Time} = \frac{16 \text{ to } 17 \text{ ADC Clock Cycles}}{\text{ADC Clock Frequency}}$$

$$\text{Number of Bus Cycles} = \text{Conversion Time} \times \text{Bus Frequency}$$

### 21.4.4 Continuous Conversion

In the continuous conversion mode, the ADC data register will be filled with new data after each conversion. Data from the previous conversion will be overwritten whether that data has been read or not. Conversions will continue until the ADCO bit (ADC status control register, \$0038) is cleared. The COCO bit is set after the first conversion and will stay set for the next several conversions until the next write of the ADC status and control register or the next read of the ADC data register.

### 21.4.5 Accuracy and Precision

The conversion process is monotonic and has no missing codes. See [29.7 ADC Characteristics](#) for accuracy information.

## 21.5 Interrupts

When the AIEN bit is set, the ADC module is capable of generating a CPU interrupt after each ADC conversion. A CPU interrupt is generated if the COCO bit (ADC status control register, \$0038) is at logic 0. If the COCO bit is set, an interrupt is generated. The COCO bit is not used as a conversion complete flag when interrupts are enabled.

## 21.6 Low-Power Modes

The following subsections describe the low-power modes.

### 21.6.1 Wait Mode

The ADC continues normal operation during wait mode. Any enabled CPU interrupt request from the ADC can bring the MCU out of wait mode. If the ADC is not required to bring the MCU out of wait mode, power down the ADC by setting the ADCH[4:0] bits in the ADC status and control register before executing the WAIT instruction.

### 21.6.2 Stop Mode

The ADC module is inactive after the execution of a STOP instruction. Any pending conversion is aborted. ADC conversions resume when the MCU exits stop mode. Allow one conversion cycle to stabilize the analog circuitry before attempting a new ADC conversion after exiting stop mode.



## 21.7 I/O Signals

The ADC module has eight channels that are shared with I/O ports B. Refer to [29.7 ADC Characteristics](#) for voltages referenced below.

### 21.7.1 ADC Analog Power Pin ( $V_{DDAREF}$ )/ADC Voltage Reference Pin ( $V_{REFH}$ )

The ADC analog portion uses  $V_{DDAREF}$  as its power pin. Connect the  $A_{VDD}/V_{DDAREF}$  pin to the same voltage potential as  $V_{DD}$ . External filtering may be necessary to ensure clean  $V_{DDAREF}$  for good results.

$V_{REFH}$  is the high reference voltage for all analog-to-digital conversions. Connect the  $V_{REFH}$  pin to a voltage potential between 1.5 volts and  $V_{DDAREF}/A_{VDD}$  depending on the desired upper conversion boundary.

**NOTE:** Route  $V_{DDAREF}$  carefully for maximum noise immunity and place bypass capacitors as close as possible to the package.

### 21.7.2 ADC Analog Ground Pin ( $A_{VSS}$ )/ADC Voltage Reference Low Pin ( $V_{REFL}$ )

The ADC analog portion uses  $A_{VSS}$  as its ground pin. Connect the  $A_{VSS}$  pin to the same voltage potential as  $V_{SS}$ .

$V_{REFL}$  is the lower reference supply for the ADC.

### 21.7.3 ADC Voltage In (ADCVIN)

ADCVIN is the input voltage signal from one of the eight ADC channels to the ADC module.

## 21.8 I/O Registers

These I/O registers control and monitor ADC operation:

- ADC status and control register (ADSCR)
- ADC data register (ADR)
- ADC clock register (ADICLK)

### 21.8.1 ADC Status and Control Register

The following paragraphs describe the function of the ADC status and control register.

Address: \$0038

	Bit 7	6	5	4	3	2	1	Bit 0
Read:	COCO	AIEN	ADCO	ADCH4	ADCH3	ADCH2	ADCH1	ADCH0
Write:	R							
Reset:	0	0	0	1	1	1	1	1

R = Reserved

**Figure 21-2. ADC Status and Control Register (ADSCR)**

#### COCO — Conversions Complete Bit

When the AIEN bit is a logic 0, the COCO is a read-only bit which is set each time a conversion is completed. This bit is cleared whenever the ADC status and control register is written or whenever the ADC data register is read.

If the AIEN bit is a logic 1, the COCO is a read/write bit which selects the CPU to service the ADC interrupt request. Reset clears this bit.

1 = Conversion completed (AIEN = 0)

0 = Conversion not completed (AIEN = 0)

or

1 = DMA interrupt enabled (AIEN = 1)

0 = CPU interrupt enabled (AIEN = 1)

#### AIEN — ADC Interrupt Enable Bit

When this bit is set, an interrupt is generated at the end of an ADC conversion. The interrupt signal is cleared when the data register is read or the status/control register is written. Reset clears the AIEN bit.

- 1 = ADC interrupt enabled
- 0 = ADC interrupt disabled

#### ADCO — ADC Continuous Conversion Bit

When set, the ADC will convert samples continuously and update the ADR register at the end of each conversion. Only one conversion is allowed when this bit is cleared. Reset clears the ADCO bit.

- 1 = Continuous ADC conversion
- 0 = One ADC conversion

#### ADCH[4:0] — ADC Channel Select Bits

ADCH4, ADCH3, ADCH2, ADCH1, and ADCH0 form a 5-bit field which is used to select one of eight ADC channels. The six channels are detailed in [Table 21-1](#). Care should be taken when using a port pin as both an analog and a digital input simultaneously to prevent switching noise from corrupting the analog signal.

The ADC subsystem is turned off when the channel select bits are all set to one. This feature allows for reduced power consumption for the MCU when the ADC is not used. Reset sets these bits.

**NOTE:** *Recovery from the disabled state requires one conversion cycle to stabilize.*

**Table 21-1. Mux Channel Select**

ADCH4	ADCH3	ADCH2	ADCH1	ADCH0	Input Select
0	0	0	0	0	PTB0/ATD0
0	0	0	0	1	PTB1/ATD1
0	0	0	1	0	PTB2/ATD2
0	0	0	1	1	PTB3/ATD3
0	0	1	0	0	PTB4/ATD4
0	0	1	0	1	PTB5/ATD5
0	0	1	1	0	PTB6/ATD6
0	0	1	1	1	PTB7/ATD7
0	1	0	0	0	Unused (see Note 1)
0	1	0	0	1	Unused (see Note 1)
0	1	0	1	0	Unused (see Note 1)
0	1	0	1	1	Unused (see Note 1)
0	1	1	0	0	Unused (see Note 1)
0	1	1	0	1	Unused (see Note 1)
0	1	1	1	0	Unused (see Note 1)
Range 01111 (\$0F) to 11010 (\$1A)					Unused (see Note 1)
					Unused (see Note 1)
1	1	0	1	1	Reserved
1	1	1	0	0	V <sub>DDAREF</sub> (see Note 2)
1	1	1	0	1	V <sub>REFH</sub> (see Note 2)
1	1	1	1	0	AV <sub>SS</sub> /V <sub>REFL</sub> (see Note 2)
1	1	1	1	1	ADC power off

**NOTES:**

1. If any unused channels are selected, the resulting ADC conversion will be unknown.
2. The voltage levels supplied from internal reference nodes as specified in the table are used to verify the operation of the ADC converter both in production test and for user applications.

### 21.8.2 ADC Data Register

One 8-bit result register is provided. This register is updated each time an ADC conversion completes.

Address: \$0039

	Bit 7	6	5	4	3	2	1	Bit 0
Read:	AD7	AD6	AD5	AD4	AD3	AD2	AD1	AD0
Write:	R	R	R	R	R	R	R	R
Reset:	Indeterminate after Reset							

R = Reserved

**Figure 21-3. ADC Data Register (ADR)**

### 21.8.3 ADC Input Clock Register

This register selects the clock frequency for the ADC.

Address: \$003A

	Bit 7	6	5	4	3	2	1	Bit 0
Read:	ADIV2	ADIV1	ADIV0	ADICLK	0	0	0	0
Write:					R	R	R	R
Reset:	0	0	0	0	0	0	0	0

R = Reserved

**Figure 21-4. ADC Input Clock Register (ADICLK)**

#### ADIV2–ADIV0 — ADC Clock Prescaler Bits

ADIV2, ADIV1, and ADIV0 form a 3-bit field which selects the divide ratio used by the ADC to generate the internal ADC clock. [Table 21-2](#) shows the available clock configurations. The ADC clock should be set to approximately 1 MHz.

**Table 21-2. ADC Clock Divide Ratio**

ADIV2	ADIV1	ADIV0	ADC Clock Rate
0	0	0	ADC Input Clock ÷ 1
0	0	1	ADC Input Clock ÷ 2
0	1	0	ADC Input Clock ÷ 4
0	1	1	ADC Input Clock ÷ 8
1	X	X	ADC Input Clock ÷ 16

X = don't care

### ADICLK — ADC Input Clock Register Bit

ADICLK selects either bus clock or CGMXCLK as the input clock source to generate the internal ADC clock. Reset selects CGMXCLK as the ADC clock source.

If the external clock (CGMXCLK) is equal to or greater than 1 MHz, CGMXCLK can be used as the clock source for the ADC. If CGMXCLK is less than 1 MHz, use the PLL-generated bus clock as the clock source. As long as the internal ADC clock is at approximately 1 MHz, correct operation can be guaranteed. (See [29.7 ADC Characteristics](#).)

1 = Internal bus clock

0 = External clock (CGMXCLK)

$$1 \text{ MHz} = \frac{f_{\text{CLK or Bus Frequency}}}{\text{ADIV}[2:0]}$$

**NOTE:** *During the conversion process, changing the ADC clock will result in an incorrect conversion.*

## Section 22. MC68HC08AZ32 Emulator Input/Output Ports

**NOTE:** This input/output (I/O) description is for **MC68HC08AZ32 emulator** only.

### 22.1 Contents

22.2	Introduction .....	368
22.3	Port A .....	370
22.3.1	Port A Data Register .....	370
22.3.2	Data Direction Register A .....	371
22.4	Port B .....	373
22.4.1	Port B Data Register .....	373
22.4.2	Data Direction Register B .....	374
22.5	Port C .....	376
22.5.1	Port C Data Register .....	376
22.5.2	Data Direction Register C .....	377
22.6	Port D .....	379
22.6.1	Port D Data Register .....	379
22.6.2	Data Direction Register D .....	380
22.7	Port E .....	382
22.7.1	Port E Data Register .....	382
22.7.2	Data Direction Register E .....	384
22.8	Port F .....	386
22.8.1	Port F Data Register .....	386
22.8.2	Data Direction Register F .....	387
22.9	Port G .....	389
22.9.1	Port G Data Register .....	389
22.9.2	Data Direction Register G .....	390
22.10	Port H .....	392

22.10.1 Port H Data Register . . . . . 392  
 22.10.2 Data Direction Register H . . . . . 393

## 22.2 Introduction

Fifty bidirectional input/output (I/O) form seven parallel ports. All I/O pins are programmable as inputs or outputs.

**NOTE:** Connect any unused I/O pins to an appropriate logic level, either  $V_{DD}$  or  $V_{SS}$ . Although the I/O ports do not require termination for proper operation, termination reduces excess current consumption and the possibility of electrostatic damage.

**Table 22-1. MC68HC08AZ32 Emulator I/O Port Register Summary**

Addr.	Register Name	Bit 7	6	5	4	3	2	1	Bit 0	
\$0000	Port A Data Register (PTA)	Read:	PTA7	PTA6	PTA5	PTA4	PTA3	PTA2	PTA1	PTA0
		Write:								
		Reset:	Unaffected by Reset							
\$0001	Port B Data Register (PTB)	Read:	PTB7	PTB6	PTB5	PTB4	PTB3	PTB2	PTB1	PTB0
		Write:								
		Reset:	Unaffected by Reset							
\$0002	Port C Data Register (PTC)	Read:	0	0	PTC5	PTC4	PTC3	PTC2	PTC1	PTC0
		Write:	R	R						
		Reset:	Unaffected by Reset							
\$0003	Port D Data Register (PTD)	Read:	PTD7	PTD6	PTD5	PTD4	PTD3	PTD2	PTD1	PTD0
		Write:								
		Reset:	Unaffected by Reset							
\$0004	Data Direction Register A (DDRA)	Read:	DDRA7	DDRA6	DDRA5	DDRA4	DDRA3	DDRA2	DDRA1	DDRA0
		Write:								
		Reset:	0	0	0	0	0	0	0	0
\$0005	Data Direction Register B (DDRB)	Read:	DDRB7	DDRB6	DDRB5	DDRB4	DDRB3	DDRB2	DDRB1	DDRB0
		Write:								
		Reset:	0	0	0	0	0	0	0	0
\$0006	Data Direction Register C (DDRC)	Read:	MCLKEN	0	DDRC5	DDRC4	DDRC3	DDRC2	DDRC1	DDRC0
		Write:		R						
		Reset:	0	0	0	0	0	0	0	0



**Table 22-1. MC68HC08AZ32 Emulator I/O Port Register Summary**

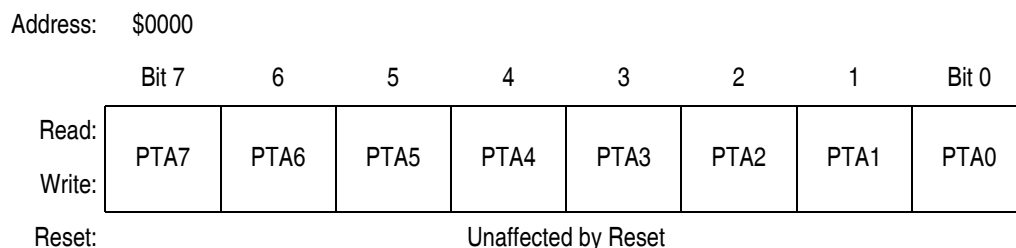
\$0007	Data Direction Register D (DDR)	Read:	<b>DDR7</b>	DDR6	DDR5	DDR4	DDR3	DDR2	DDR1	DDR0
		Write:								
		Reset:	0	0	0	0	0	0	0	0
\$0008	Port E Data Register (PTE)	Read:	PTE7	PTE6	PTE5	PTE4	PTE3	PTE2	PTE1	PTE0
		Write:								
		Reset:	Unaffected by Reset							
\$0009	Port F Data Register (PTF)	Read:	0	<b>PTF6</b>	<b>PTF5</b>	<b>PTF4</b>	PTF3	PTF2	PTF1	PTF0
		Write:	R							
		Reset:	Unaffected by Reset							
\$000A	Port G Data Register (PTG)	Read:	0	0	0	0	0	<b>PTG2</b>	<b>PTG1</b>	<b>PTG0</b>
		Write:	R	R	R	R	R			
		Reset:	Unaffected by Reset							
\$000B	Port H Data Register (PTH)	Read:	0	0	0	0	0	0	<b>PTH1</b>	<b>PTH0</b>
		Write:	R	R	R	R	R	R		
		Reset:	Unaffected by Reset							
\$000C	Data Direction Register E (DDE)	Read:	DDRE7	DDRE6	DDRE5	DDRE4	DDRE3	DDRE2	DDRE1	DDRE0
		Write:								
		Reset:	0	0	0	0	0	0	0	0
\$000D	Data Direction Register F (DDRF)	Read:	0	<b>DDRF6</b>	<b>DDRF5</b>	<b>DDRF4</b>	DDRF3	DDRF2	DDRF1	DDRF0
		Write:	R							
		Reset:	0	0	0	0	0	0	0	0
\$000E	Data Direction Register G (DDRG)	Read:	0	0	0	0	0	<b>DDRG2</b>	<b>DDRG1</b>	<b>DDRG0</b>
		Write:	R	R	R	R	R			
		Reset:	0	0	0	0	0	0	0	0
\$000F	Data Direction Register H (DDRH)	Read:	0	0	0	0	0	0	<b>DDRH1</b>	<b>DDRH0</b>
		Write:	R	R	R	R	R	R		
		Reset:	0	0	0	0	0	0	0	0

## 22.3 Port A

Port A is an 8-bit general-purpose bidirectional I/O port.

### 22.3.1 Port A Data Register

The port A data register contains a data latch for each of the eight port A pins.



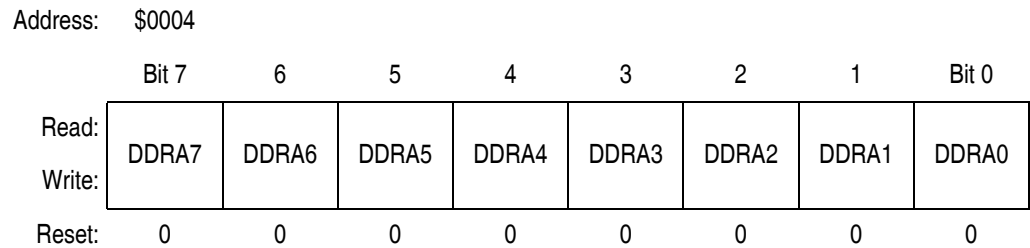
**Figure 22-1. Port A Data Register (PTA)**

#### PTA[7:0] — Port A Data Bits

These read/write bits are software programmable. Data direction of each port A pin is under the control of the corresponding bit in data direction register A. Reset has no effect on port A data.

### 22.3.2 Data Direction Register A

Data direction register A determines whether each port A pin is an input or an output. Writing a logic 1 to a DDRA bit enables the output buffer for the corresponding port A pin; a logic 0 disables the output buffer.



**Figure 22-2. Data Direction Register A (DDRA)**

#### DDRA[7:0] — Data Direction Register A Bits

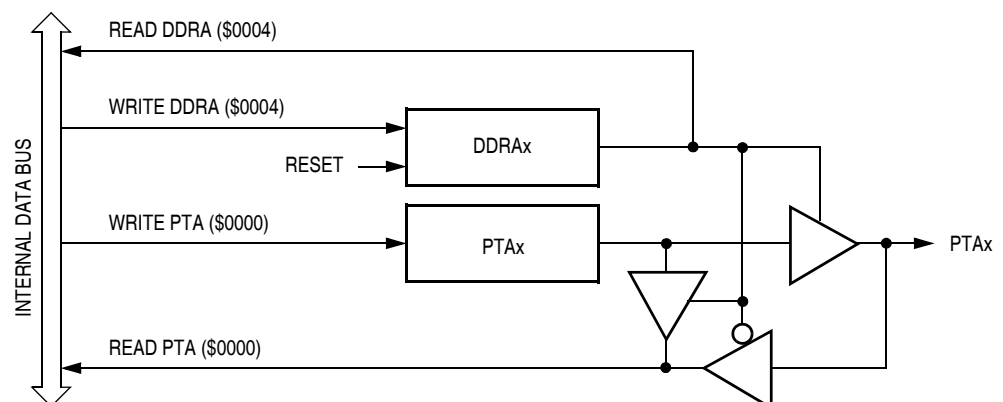
These read/write bits control port A data direction. Reset clears DDRA[7:0], configuring all port A pins as inputs.

1 = Corresponding port A pin configured as output

0 = Corresponding port A pin configured as input

**NOTE:** Avoid glitches on port A pins by writing to the port A data register before changing data direction register A bits from 0 to 1.

Figure 22-3 shows the port A I/O logic.



**Figure 22-3. Port A I/O Circuit**

When bit DDRA<sub>x</sub> is a logic 1, reading address \$0000 reads the PTA<sub>x</sub> data latch. When bit DDRA<sub>x</sub> is a logic 0, reading address \$0000 reads the voltage level on the pin. The data latch can always be written, regardless of the state of its data direction bit. [Table 22-2](#) summarizes the operation of the port A pins.

**Table 22-2. Port A Pin Functions**

DDRA Bit	PTA Bit	I/O Pin Mode	Accesses to DDRA	Accesses to PTA	
			Read/Write	Read	Write
0	X	Input, Hi-Z	DDRA[7:0]	Pin	PTA[7:0] <sup>(1)</sup>
1	X	Output	DDRA[7:0]	PTA[7:0]	PTA[7:0]

X = don't care

Hi-Z = high impedance

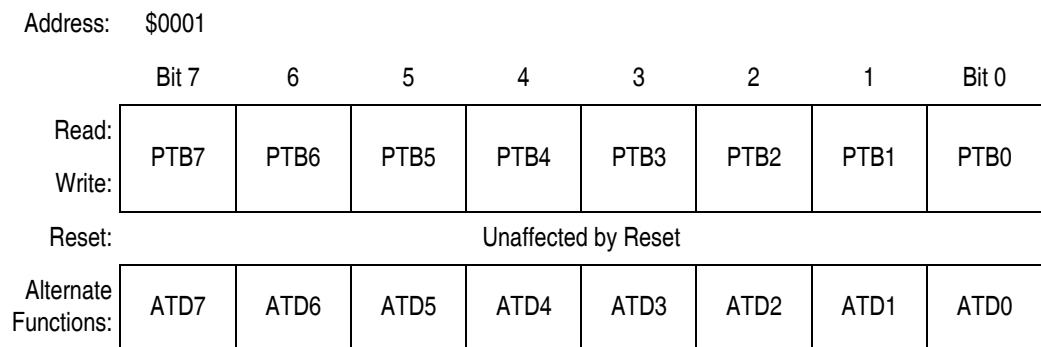
1. Writing affects data register, but does not affect input.

## 22.4 Port B

Port B is an 8-bit special function port that shares all of its pins with the analog-to-digital converter.

### 22.4.1 Port B Data Register

The port B data register contains a data latch for each of the eight port B pins.



**Figure 22-4. Port B Data Register (PTB)**

#### PTB[7:0] — Port B Data Bits

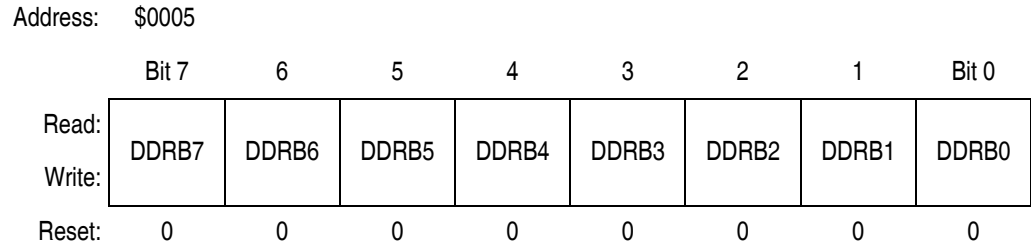
These read/write bits are software programmable. Data direction of each port B pin is under the control of the corresponding bit in data direction register B. Reset has no effect on port B data.

#### ATD[7:0] — ADC Channels

PTB7/ATD7–PTB0/ATD0 are eight of the analog-to-digital converter channels. The ADC channel select bits, CH[4:0], determine whether the PTB7/ATD7–PTB0/ATD0 pins are ADC channels or general-purpose I/O pins. If an ADC channel is selected and a read of this corresponding bit in the port B data register occurs, the data will be 0 if the data direction for this bit is programmed as an input. Otherwise, the data will reflect the value in the data latch. (See [Section 21. Analog-to-Digital Converter \(ADC-8\)](#).) Data direction register B (DDRB) does not affect the data direction of port B pins that are being used by the ADC. However, the DDRB bits always determine whether reading port B returns to the states of the latches or logic 0.

## 22.4.2 Data Direction Register B

Data direction register B determines whether each port B pin is an input or an output. Writing a logic 1 to a DDRB bit enables the output buffer for the corresponding port B pin; a logic 0 disables the output buffer.



**Figure 22-5. Data Direction Register B (DDRB)**

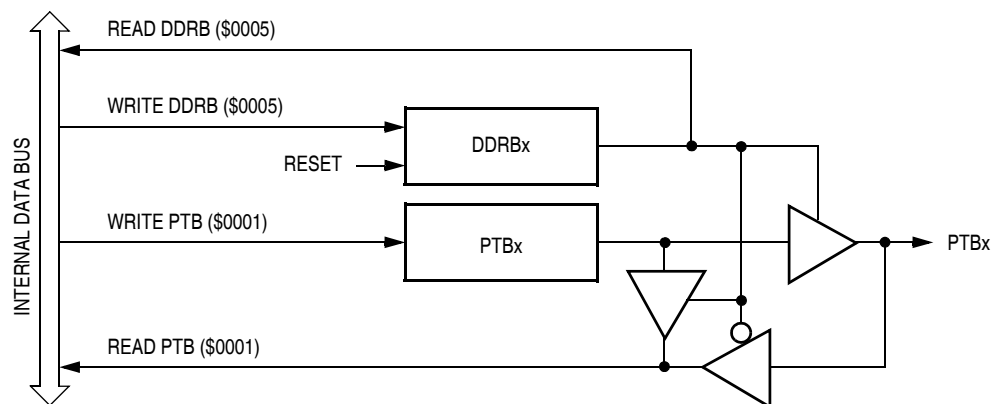
### DDRB[7:0] — Data Direction Register B Bits

These read/write bits control port B data direction. Reset clears DDRB[7:0], configuring all port B pins as inputs.

- 1 = Corresponding port B pin configured as output
- 0 = Corresponding port B pin configured as input

**NOTE:** Avoid glitches on port B pins by writing to the port B data register before changing data direction register B bits from 0 to 1.

Figure 22-6 shows the port B I/O logic.



**Figure 22-6. Port B I/O Circuit**

When bit DDRBx is a logic 1, reading address \$0001 reads the PTBx data latch. When bit DDRBx is a logic 0, reading address \$0001 reads the voltage level on the pin. The data latch can always be written, regardless of the state of its data direction bit. [Table 22-3](#) summarizes the operation of the port B pins.

**Table 22-3. Port B Pin Functions**

DDR B Bit	PTB Bit	I/O Pin Mode	Accesses to DDRB	Accesses to PTB	
			Read/Write	Read	Write
0	X	Input, Hi-Z	DDR B[7:0]	Pin	PTB[7:0] <sup>(1)</sup>
1	X	Output	DDR B[7:0]	PTB[7:0]	PTB[7:0]

X = don't care

Hi-Z = high impedance

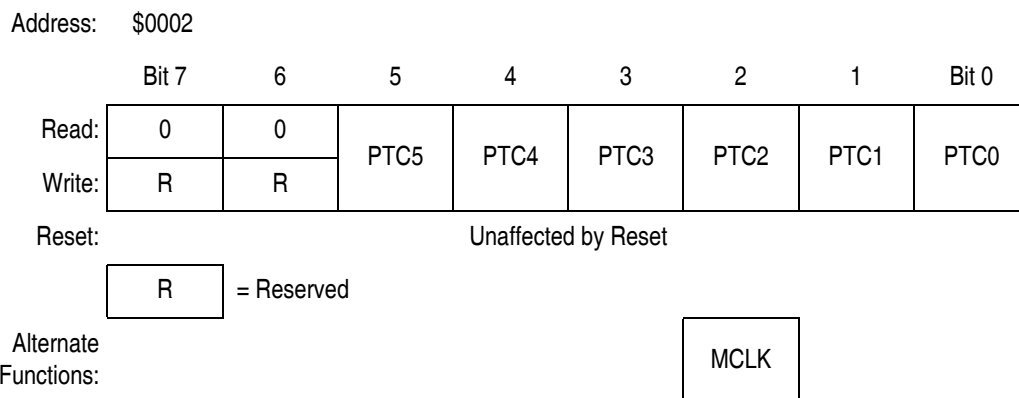
1. Writing affects data register, but does not affect input.

## 22.5 Port C

Port C is an 6-bit general-purpose bidirectional I/O port.

### 22.5.1 Port C Data Register

The port C data register contains a data latch for each of the six port C pins.



**Figure 22-7. Port C Data Register (PTC)**

#### PTC[5:0] — Port C Data Bits

These read/write bits are software-programmable. Data direction of each port C pin is under the control of the corresponding bit in data direction register C. Reset has no effect on port C data (5:0).

#### MCLK — T12 System Clock Bit

The system clock is driven out of PTC2 when enabled by MCLKEN bit in PTCDDR7.



## 22.5.2 Data Direction Register C

Data direction register C determines whether each port C pin is an input or an output. Writing a logic 1 to a DDRC bit enables the output buffer for the corresponding port C pin; a logic 0 disables the output buffer.

Address: \$0006

	Bit 7	6	5	4	3	2	1	Bit 0
Read:	MCLKEN	0	DDRC5	DDRC4	DDRC3	DDRC2	DDRC1	DDRC0
Write:	MCLKEN	R	DDRC5	DDRC4	DDRC3	DDRC2	DDRC1	DDRC0
Reset:	0	0	0	0	0	0	0	0

R = Reserved

**Figure 22-8. Data Direction Register C (DDRC)**

### MCLKEN — MCLK Enable Bit

This read/write bit enables MCLK to be an output signal on PTC2. If MCLK is enabled, DDRC2 has no effect. Reset clears this bit.

- 1 = MCLK output enabled
- 0 = MCLK output disabled

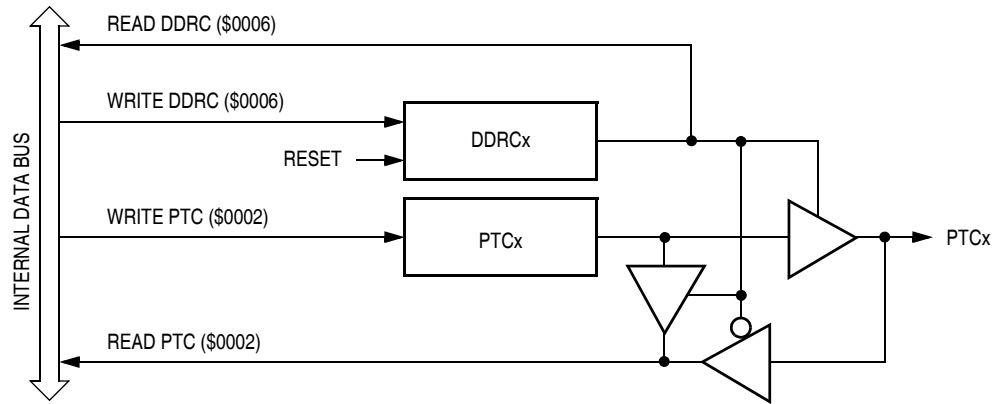
### DDRC[5:0] — Data Direction Register C Bits

These read/write bits control port C data direction. Reset clears DDRC[7:0], configuring all port C pins as inputs.

- 1 = Corresponding port C pin configured as output
- 0 = Corresponding port C pin configured as input

**NOTE:** *Avoid glitches on port C pins by writing to the port C data register before changing data direction register C bits from 0 to 1.*

**Figure 22-9** shows the port C I/O logic.



**Figure 22-9. Port C I/O Circuit**

When bit DDRCx is a logic 1, reading address \$0002 reads the PTCx data latch. When bit DDRCx is a logic 0, reading address \$0002 reads the voltage level on the pin. The data latch can always be written, regardless of the state of its data direction bit. [Table 22-4](#) summarizes the operation of the port C pins.

**Table 22-4. Port C Pin Functions**

Bit Value	PTC Bit	I/O Pin Mode	Accesses to DDRC	Accesses to PTC	
			Read/Write	Read	Write
0	2	Input, Hi-Z	DDRC[2]	Pin	PTC2
1	2	Output	DDRC[2]	0	—
0	X	Input, Hi-Z	DDRC[5:0]	Pin	PTC[5:0] <sup>(1)</sup>
1	X	Output	DDRC[5:0]	PTC[5:0]	PTC[5:0]

X = don't care

Hi-Z = high impedance

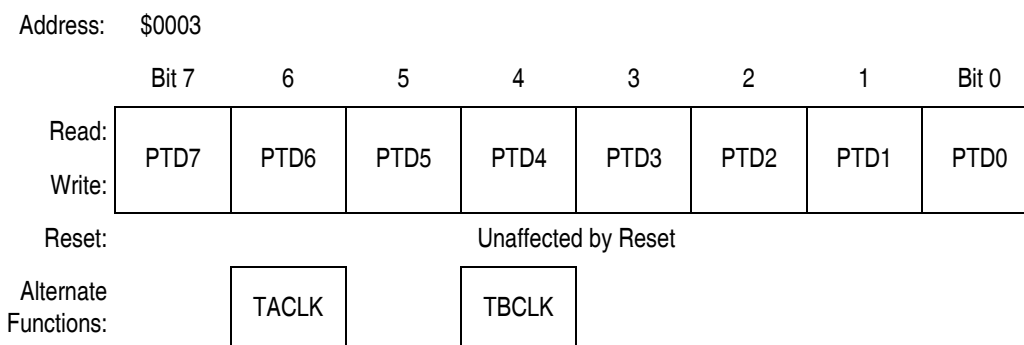
1. Writing affects data register, but does not affect input.

## 22.6 Port D

Port D is an 8-bit general-purpose I/O port.

### 22.6.1 Port D Data Register

Port D is a 8-bit special function port that shares two of its pins with the timer interface modules.



**Figure 22-10. Port D Data Register (PTD)**

#### PTD[7:0] — Port D Data Bits

PTD[7:0] are read/write, software programmable bits. Data direction of PTD[7:0] pins are under the control of the corresponding bit in data direction register D.

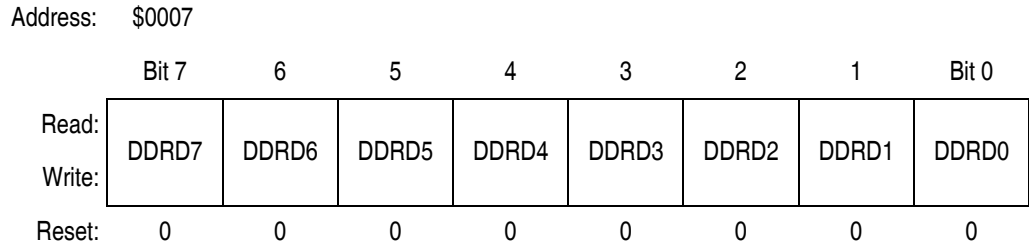
**NOTE:** *Data direction register D (DDRD) does not affect the data direction of port D pins that are being used by the TIMA or TIMB. However, the DDRD bits always determine whether reading port D returns the states of the latches or logic 0.*

#### TACLK/TBCLK — Timer Clock Input Bit

The PTD6/TACLK pin is the external clock input for the TIMA. The PTD4/TBCLK pin is the external clock input for the TIMB. The prescaler select bits, PS[2:0], select PTD6/TACLK or PTD4/TBCLK as the TIM clock input. (See [18.9.4 TIMA Channel Status and Control Registers](#) and [19.9.1 TIMB Status and Control Register](#).) When not selected as the TIM clock, PTD6/TACLK and PTD4/TBCLK are available for general-purpose I/O. While TACLK/TBCLK are selected corresponding DDRD bits have no effect.

## 22.6.2 Data Direction Register D

Data direction register D determines whether each port D pin is an input or an output. Writing a logic 1 to a DDRD bit enables the output buffer for the corresponding port D pin; a logic 0 disables the output buffer.



**Figure 22-11. Data Direction Register D (DDRD)**

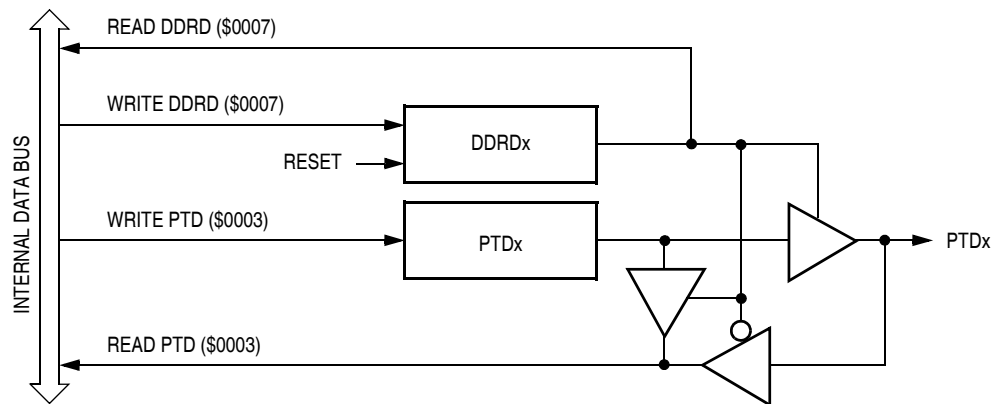
### DDRD[7:0] — Data Direction Register D Bits

These read/write bits control port D data direction. Reset clears DDRD[7:0], configuring all port D pins as inputs.

- 1 = Corresponding port D pin configured as output
- 0 = Corresponding port D pin configured as input

**NOTE:** *Avoid glitches on port D pins by writing to the port D data register before changing data direction register D bits from 0 to 1.*

Figure 22-12 shows the port D I/O logic.



**Figure 22-12. Port D I/O Circuit**

When bit DDRDx is a logic 1, reading address \$0003 reads the PTDx data latch. When bit DDRDx is a logic 0, reading address \$0003 reads the voltage level on the pin. The data latch can always be written, regardless of the state of its data direction bit. [Table 22-5](#) summarizes the operation of the port D pins.

**Table 22-5. Port D Pin Functions**

DDRD Bit	PTD Bit	I/O Pin Mode	Accesses to DDRD	Accesses to PTD	
			Read/Write	Read	Write
0	X	Input, Hi-Z	DDRD[7:0]	Pin	PTD[7:0] <sup>(1)</sup>
1	X	Output	DDRD[7:0]	PTD[7:0]	PTD[7:0]

X = don't care

Hi-Z = high impedance

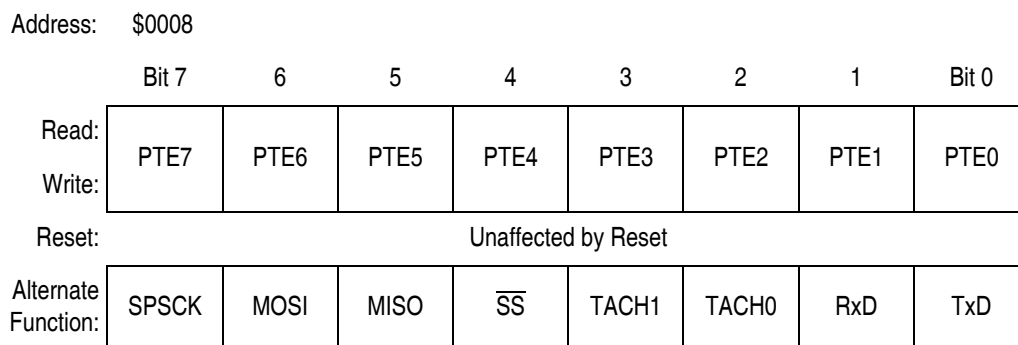
1. Writing affects data register, but does not affect input.

## 22.7 Port E

Port E is an 8-bit special function port that shares two of its pins with the timer interface module (TIMA), two of its pins with the serial communications interface module (SCI), and four of its pins with the serial peripheral interface module (SPI).

### 22.7.1 Port E Data Register

The port E data register contains a data latch for each of the eight port E pins.



**Figure 22-13. Port E Data Register (PTE)**

#### PTE[7:0] — Port E Data Bits

PTE[7:0] are read/write, software programmable bits. Data direction of each port E pin is under the control of the corresponding bit in data direction register E.

#### SPSCK — SPI Serial Clock Bit

The PTE7/SPSCK pin is the serial clock input of an SPI slave module and serial clock output of an SPI master module. When the SPE bit is clear, the PTE7/SPSCK pin is available for general-purpose I/O. (See [17.14.1 SPI Control Register](#).)

#### MOSI — Master Out/Slave In Bit

The PTE6/MOSI pin is the master out/slave in terminal of the SPI module. When the SPE bit is clear, the PTE6/MOSI pin is available for general-purpose I/O.

### MISO — Master In/Slave Out Bit

The PTE5/MISO pin is the master in/slave out terminal of the SPI module. When the SPI enable bit, SPE, is clear, the SPI module is disabled, and the PTE5/MISO pin is available for general-purpose I/O. (See [17.14.1 SPI Control Register](#).)

### $\overline{SS}$ — Slave Select Bit

The PTE4/ $\overline{SS}$  pin is the slave select input of the SPI module. When the SPE bit is clear, or when the SPI master bit, SPMSTR, is set and MODFEN bit is low, the PTE4/ $\overline{SS}$  pin is available for general-purpose I/O. (See [17.13.4 SS \(Slave Select\)](#).) When the SPI is enabled as a slave, the DDRF0 bit in data direction register E (DDRE) has no effect on the PTE4/ $\overline{SS}$  pin.

**NOTE:** *Data direction register E (DDRE) does not affect the data direction of port E pins that are being used by the SPI module. However, the DDRE bits always determine whether reading port E returns the states of the latches or the states of the pins. (See [Table 22-6](#).)*

### TACH[1:0] — Timer Channel I/O Bits

The PTE3/TACH1–PTE2/TACH0 pins are the TIM input capture/output compare pins. The edge/level select bits, ELSxB:ELSxA, determine whether the PTE3/TACH1–PTE2/TACH0 pins are timer channel I/O pins or general-purpose I/O pins. (See [18.9.4 TIMA Channel Status and Control Registers](#).)

**NOTE:** *Data direction register E (DDRE) does not affect the data direction of port E pins that are being used by the TIM. However, the DDRE bits always determine whether reading port E returns the states of the latches or the states of the pins. (See [Table 22-6](#).)*

### RxD — SCI Receive Data Input Bit

The PTE1/RxD pin is the receive data input for the SCI module. When the enable SCI bit, ENSCI, is clear, the SCI module is disabled, and the PTE1/RxD pin is available for general-purpose I/O. (See [16.9.1 SCI Control Register 1](#).)

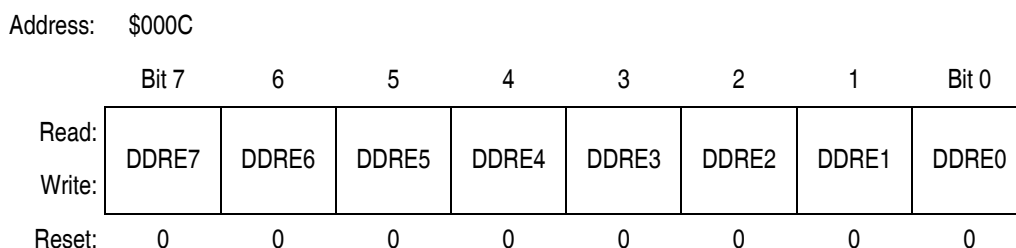
## TxD — SCI Transmit Data Output

The PTE0/TxD pin is the transmit data output for the SCI module. When the enable SCI bit, ENSCI, is clear, the SCI module is disabled, and the PTE0/TxD pin is available for general-purpose I/O. (See [16.9.1 SCI Control Register 1](#).)

**NOTE:** *Data direction register E (DDRE) does not affect the data direction of port E pins that are being used by the SCI module. However, the DDRE bits always determine whether reading port E returns the states of the latches or the states of the pins. (See [Table 22-6](#).)*

## 22.7.2 Data Direction Register E

Data direction register E determines whether each port E pin is an input or an output. Writing a logic 1 to a DDRE bit enables the output buffer for the corresponding port E pin; a logic 0 disables the output buffer.



**Figure 22-14. Data Direction Register E (DDRE)**

### DDRE[7:0] — Data Direction Register E Bits

These read/write bits control port E data direction. Reset clears DDRE[7:0], configuring all port E pins as inputs.

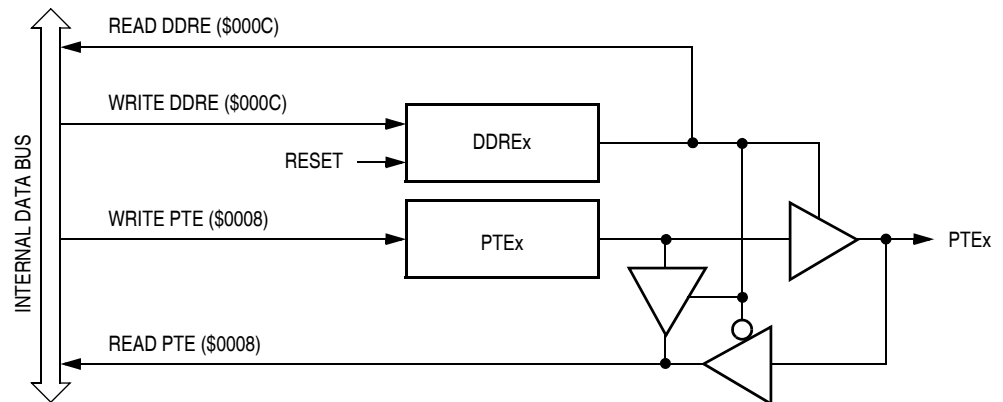
1 = Corresponding port E pin configured as output

0 = Corresponding port E pin configured as input

**NOTE:** *Avoid glitches on port E pins by writing to the port E data register before changing data direction register E bits from 0 to 1.*

[Figure 22-15](#) shows the port E I/O logic.




**Figure 22-15. Port E I/O Circuit**

When bit DDREx is a logic 1, reading address \$0008 reads the PTEx data latch. When bit DDREx is a logic 0, reading address \$0008 reads the voltage level on the pin. The data latch can always be written, regardless of the state of its data direction bit. [Table 22-6](#) summarizes the operation of the port E pins.

**Table 22-6. Port E Pin Functions**

DDRE Bit	PTE Bit	I/O Pin Mode	Accesses to DDRE	Accesses to PTE	
			Read/Write	Read	Write
0	X	Input, Hi-Z	DDRE[7:0]	Pin	PTE[7:0] <sup>(1)</sup>
1	X	Output	DDRE[7:0]	PTE[7:0]	PTE[7:0]

X = don't care

Hi-Z = high impedance

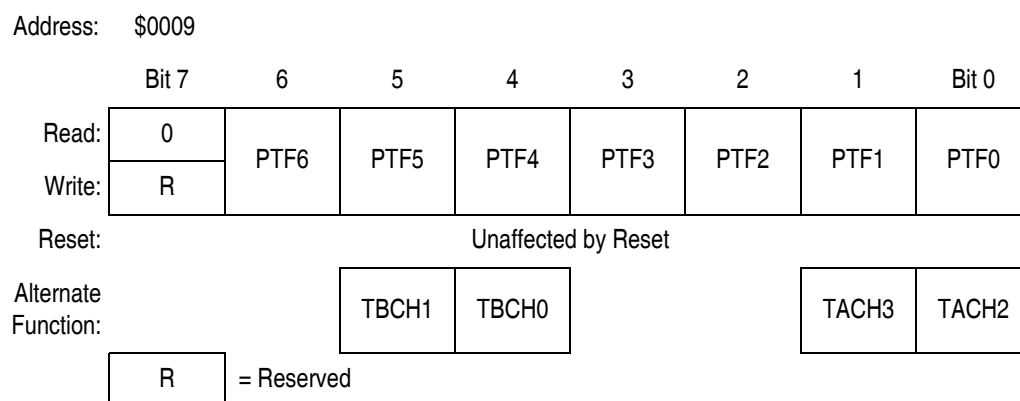
1. Writing affects data register, but does not affect input.

## 22.8 Port F

Port F is a 7-bit special function port that shares two of its pins with the timer interface module (TIMA-4) and two of its pins with the timer interface module (TIMB).

### 22.8.1 Port F Data Register

The port F data register contains a data latch for each of the seven port F pins.



**Figure 22-16. Port F Data Register (PTF)**

#### PTF[6:0] — Port F Data Bits

These read/write bits are software programmable. Data direction of each port F pin is under the control of the corresponding bit in data direction register F. Reset has no effect on PTF[6:0].

#### TACH[3:2] — Timer A Channel I/O Bits

The PTF1/TACH3–PTF0/TACH2 pins are the TIM input capture/output compare pins. The edge/level select bits, ELSxB:ELSxA, determine whether the PTF1/TACH3–PTF0/TACH2 pins are timer channel I/O pins or general-purpose I/O pins. (See [18.9.1 TIMA Status and Control Register](#).)

### TBCH[1:0] — Timer B Channel I/O Bits

The PTF5/TBCH1–PTF4/TBCH0 pins are the TIMB input capture/output compare pins. The edge/level select bits, ELSxB:ELSxA, determine whether the PTF5/TBCH1–PTF4/TBCH0 pins are timer channel I/O pins or general-purpose I/O pins. (See [19.9.1 TIMB Status and Control Register](#).)

**NOTE:** *Data direction register F (DDRF) does not affect the data direction of port F pins that are being used by the TIM. However, the DDRF bits always determine whether reading port F returns the states of the latches or the states of the pins. (See [Table 22-7](#).)*

## 22.8.2 Data Direction Register F

Data direction register F determines whether each port F pin is an input or an output. Writing a logic 1 to a DDRF bit enables the output buffer for the corresponding port F pin; a logic 0 disables the output buffer.

Address: \$000D

	Bit 7	6	5	4	3	2	1	Bit 0
Read:	0	DDRF6	DDRF5	DDRF4	DDRF3	DDRF2	DDRF1	DDRF0
Write:	R							
Reset:	0	0	0	0	0	0	0	0

R = Reserved

**Figure 22-17. Data Direction Register F (DDRF)**

### DDRF[6:0] — Data Direction Register F Bits

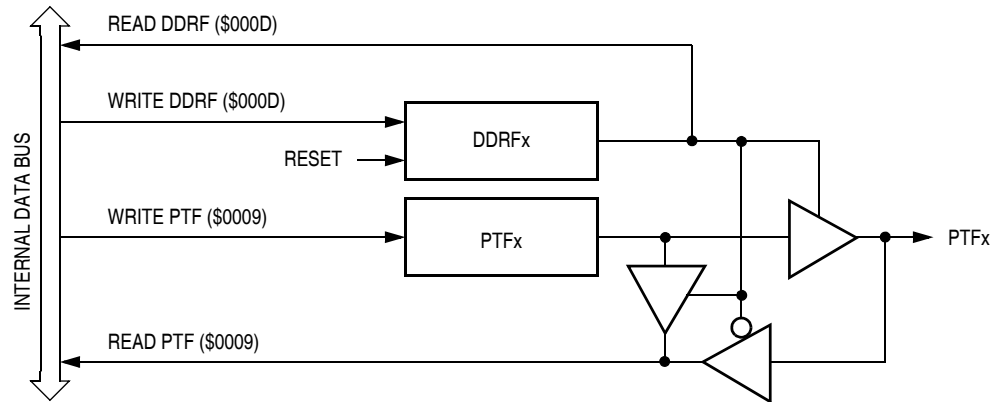
These read/write bits control port F data direction. Reset clears DDRF[6:0], configuring all port F pins as inputs.

1 = Corresponding port F pin configured as output

0 = Corresponding port F pin configured as input

**NOTE:** *Avoid glitches on port F pins by writing to the port F data register before changing data direction register F bits from 0 to 1.*

[Figure 22-18](#) shows the port F I/O logic.



**Figure 22-18. Port F I/O Circuit**

When bit DDRFx is a logic 1, reading address \$0009 reads the PTFx data latch. When bit DDRFx is a logic 0, reading address \$0009 reads the voltage level on the pin. The data latch can always be written, regardless of the state of its data direction bit. [Table 22-7](#) summarizes the operation of the port F pins.

**Table 22-7. Port F Pin Functions**

DDRF Bit	PTF Bit	I/O Pin Mode	Accesses to DDRF	Accesses to PTF	
			Read/Write	Read	Write
0	X	Input, Hi-Z	DDRF[6:0]	Pin	PTF[6:0] <sup>(1)</sup>
1	X	Output	DDRF[6:0]	PTF[6:0]	PTF[6:0]

X = don't care

Hi-Z = high impedance

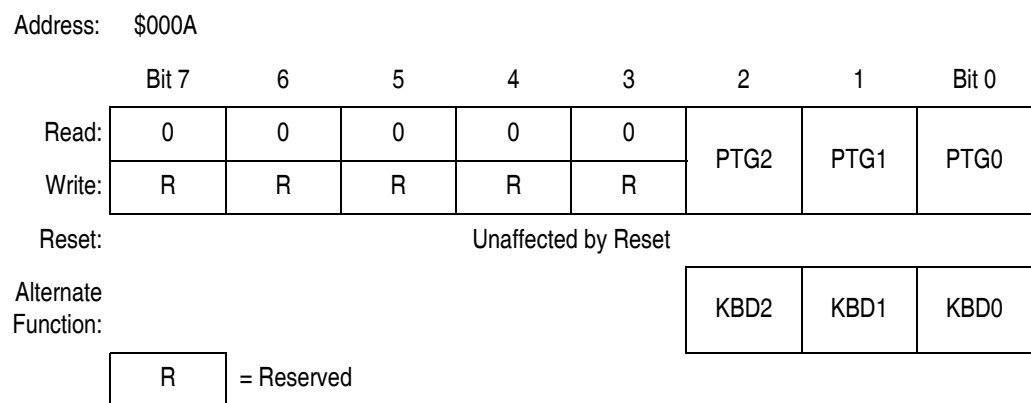
1. Writing affects data register, but does not affect input.

## 22.9 Port G

Port G is a 3-bit special function port that shares all of its pins with the keyboard interrupt module (KBD).

### 22.9.1 Port G Data Register

The port G data register contains a data latch for each of the three port G pins.



**Figure 22-19. Port G Data Register (PTG)**

#### PTG[2:0] — Port G Data Bits

These read/write bits are software programmable. Data direction of each port G pin is under the control of the corresponding bit in data direction register G. Reset has no effect on PTG[2:0].

#### KBD[2:0] — Keyboard Wakeup pins

The keyboard interrupt enable bits, KBIE[2:0], in the keyboard interrupt control register, enable the port G pins as external interrupt pins (See [Section 24. Keyboard Interrupt Module \(KBD\)](#).) Enabling an external interrupt pin will override the corresponding DDRGx.

## 22.9.2 Data Direction Register G

Data direction register G determines whether each port G pin is an input or an output. Writing a logic 1 to a DDRG bit enables the output buffer for the corresponding port G pin; a logic 0 disables the output buffer.

Address: \$000E

	Bit 7	6	5	4	3	2	1	Bit 0
Read:	0	0	0	0	0	DDRG2	DDRG1	DDRG0
Write:	R	R	R	R	R			
Reset:	0	0	0	0	0	0	0	0

R = Reserved

**Figure 22-20. Data Direction Register G (DDRG)**

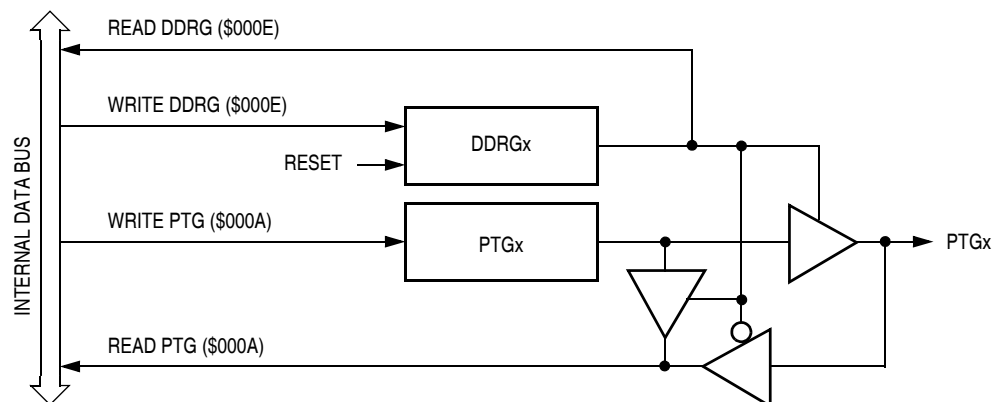
### DDRG[2:0] — Data Direction Register G Bits

These read/write bits control port G data direction. Reset clears DDRG[2:0], configuring all port G pins as inputs.

- 1 = Corresponding port G pin configured as output
- 0 = Corresponding port G pin configured as input

**NOTE:** Avoid glitches on port G pins by writing to the port G data register before changing data direction register G bits from 0 to 1.

Figure 22-18 shows the port G I/O logic.



**Figure 22-21. Port G I/O Circuit**

When bit DDRGx is a logic 1, reading address \$000A reads the PTGx data latch. When bit DDRGx is a logic 0, reading address \$000A reads the voltage level on the pin. The data latch can always be written, regardless of the state of its data direction bit. [Table 22-8](#) summarizes the operation of the port G pins.

**Table 22-8. Port G Pin Functions**

DDRG Bit	PTG Bit	I/O Pin Mode	Accesses to DDRG	Accesses to PTG	
			Read/Write	Read	Write
0	X	Input, Hi-Z	DDRG[2:0]	Pin	PTG[2:0] <sup>(1)</sup>
1	X	Output	DDRG[2:0]	PTG[2:0]	PTG[2:0]

X = don't care

Hi-Z = high impedance

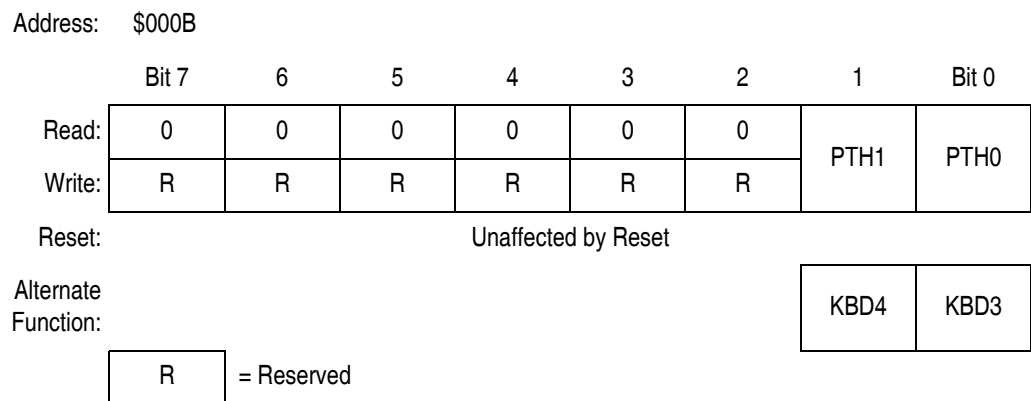
1. Writing affects data register, but does not affect input.

## 22.10 Port H

Port H is a 2-bit special function port that shares all of its pins with the keyboard interrupt module (KBD).

### 22.10.1 Port H Data Register

The port H data register contains a data latch for each of the two port H pins.



**Figure 22-22. Port H Data Register (PTH)**

#### PTH[1:0] — Port H Data Bits

These read/write bits are software programmable. Data direction of each port H pin is under the control of the corresponding bit in data direction register H. Reset has no effect on PTH[1:0].

#### KBD[4:3] — Keyboard Wake-up pins

The keyboard interrupt enable bits, KBIE[4:3], in the keyboard interrupt control register, enable the port H pins as external interrupt pins (See [Section 24. Keyboard Interrupt Module \(KBD\)](#).)



## 22.10.2 Data Direction Register H

Data direction register H determines whether each port H pin is an input or an output. Writing a logic 1 to a DDRH bit enables the output buffer for the corresponding port H pin; a logic 0 disables the output buffer.

Address: \$000F

	Bit 7	6	5	4	3	2	1	Bit 0
Read:	0	0	0	0	0	0	DDRH1	DDRH0
Write:	R	R	R	R	R	R		
Reset:	0	0	0	0	0	0	0	0

R = Reserved

**Figure 22-23. Data Direction Register H (DDRH)**

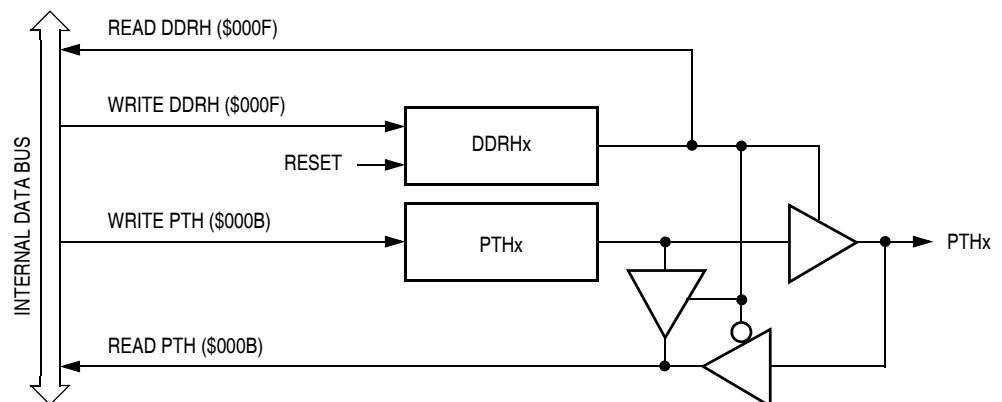
### DDRH[1:0] — Data Direction Register H Bits

These read/write bits control port H data direction. Reset clears DDRG[1:0], configuring all port H pins as inputs.

- 1 = Corresponding port H pin configured as output
- 0 = Corresponding port H pin configured as input

**NOTE:** Avoid glitches on port H pins by writing to the port H data register before changing data direction register H bits from 0 to 1.

Figure 22-24 shows the port H I/O logic.



**Figure 22-24. Port H I/O Circuit**

When bit DDRHx is a logic 1, reading address \$000B reads the PTHx data latch. When bit DDRHx is a logic 0, reading address \$000B reads the voltage level on the pin. The data latch can always be written, regardless of the state of its data direction bit. [Table 22-9](#) summarizes the operation of the port H pins.

**Table 22-9. Port H Pin Functions**

DDRH Bit	PTH Bit	I/O Pin Mode	Accesses to DDRH	Accesses to PTH	
			Read/Write	Read	Write
0	X	Input, Hi-Z	DDRH[1:0]	Pin	PTH[1:0] <sup>(1)</sup>
1	X	Output	DDRH[1:0]	PTH[1:0]	PTH[1:0]

X = don't care

Hi-Z = high impedance

1. Writing affects data register, but does not affect input.

## Section 23. MSCAN Controller

### 23.1 Contents

23.2	Introduction . . . . .	396
23.3	Features . . . . .	397
23.4	External Pins. . . . .	398
23.5	Message Storage . . . . .	399
23.5.1	Background . . . . .	399
23.5.2	Receive Structures . . . . .	400
23.5.3	Transmit Structures . . . . .	403
23.6	Identifier Acceptance Filter . . . . .	404
23.7	Interrupts . . . . .	407
23.7.1	Interrupt Acknowledge . . . . .	408
23.7.2	Interrupt Vectors . . . . .	408
23.8	Protocol Violation Protection . . . . .	409
23.9	Low-Power Modes . . . . .	409
23.9.1	MSCAN08 Internal Sleep Mode . . . . .	409
23.9.2	CPU Wait Mode . . . . .	411
23.9.3	CPU Stop Mode . . . . .	411
23.9.4	Programmable Wakeup Function . . . . .	411
23.10	Timer Link . . . . .	411
23.11	Clock System . . . . .	412
23.12	Memory Map . . . . .	415
23.13	Programmer’s Model of Message Storage . . . . .	415
23.13.1	Message Buffer Outline . . . . .	416
23.13.2	Identifier Registers . . . . .	417
23.13.3	Data Length Register (DLR) . . . . .	420

23.13.4	Data Segment Registers (DSRn) . . . . .	420
23.13.5	Transmit Buffer Priority Registers . . . . .	421
23.14	Programmer's Model of Control Registers . . . . .	422
23.14.1	MSCAN08 Module Control Register . . . . .	424
23.14.2	MSCAN08 Module Control Register . . . . .	426
23.14.3	MSCAN08 Bus Timing Register 0 . . . . .	427
23.14.4	MSCAN08 Bus Timing Register 1 . . . . .	428
23.14.5	MSCAN08 Receiver Flag Register (CRFLG) . . . . .	430
23.14.6	MSCAN08 Receiver Interrupt Enable Register . . . . .	432
23.14.7	MSCAN08 Transmitter Flag Register . . . . .	433
23.14.8	MSCAN08 Transmitter Control Register . . . . .	435
23.14.9	MSCAN08 Identifier Acceptance Control Register (CIDAC) . . . . .	436
23.14.10	MSCAN08 Receive Error Counter . . . . .	437
23.14.11	MSCAN08 Transmit Error Counter . . . . .	438
23.14.12	MSCAN08 Identifier Acceptance Registers . . . . .	438
23.14.13	MSCAN08 Identifier Mask Registers (CIDMR0-3) . . . . .	440

## 23.2 Introduction

The MSCAN08 is the specific implementation of the scalable controller area network (MSCAN) concept targeted for the Freescale M68HC08 Microcontroller Family.

The module is a communication controller implementing the CAN 2.0 A/B protocol as defined in the BOSCH specification dated September 1991.

The CAN protocol was primarily, but not exclusively, designed to be used as a vehicle serial data bus, meeting the specific requirements of this field: real-time processing, reliable operation in the electromagnetic interference (EMI) environment of a vehicle, cost-effectiveness and required bandwidth.

MSCAN08 utilizes an advanced buffer arrangement, resulting in a predictable real-time behavior, and simplifies the application software.

## 23.3 Features

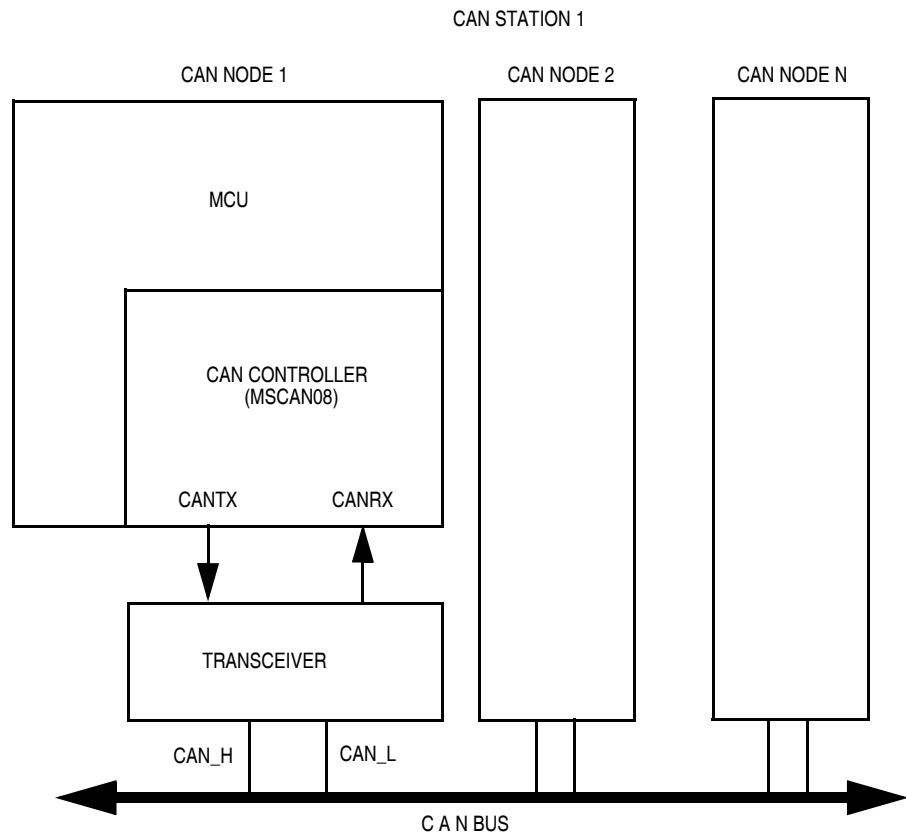
Basic features of the MSCAN08 are:

- Modular Architecture
- Implementation of the CAN Protocol — Version 2.0A/B
  - Standard and Extended Data Frames.
  - 0–8 Bytes Data Length.
  - Programmable Bit Rate up to 1 Mbps Depending on the Actual Bit Timing and the Clock Jitter of the PLL
- Support for Remote Frames
- Double-Buffered Receive Storage Scheme
- Triple-Buffered Transmit Storage Scheme with Internal Prioritisation Using a “Local Priority” Concept
- Flexible Maskable Identifier Filter Supports Alternatively One Full Size Extended Identifier Filter or Two 16-Bit Filters or Four 8-Bit Filters
- Programmable Wakeup Functionality with Integrated Low-Pass Filter
- Programmable Loop-Back Mode Supports Self-Test Operation
- Separate Signalling and Interrupt Capabilities for All CAN Receiver and Transmitter Error States (Warning, Error Passive, Bus Off)
- Programmable MSCAN08 Clock Source Either CPU Bus Clock or Crystal Oscillator Output
- Programmable Link to On-Chip Timer Interface Module (TIMB) for Time-Stamping and Network Synchronization
- Low-Power Sleep Mode

## 23.4 External Pins

The MSCAN08 uses two external pins, one input (CANRx) and one output (CANTx). The CANTx output pin represents the logic level on the CAN: 0 is for a dominant state, and 1 is for a recessive state.

A typical CAN system with MSCAN08 is shown in [Figure 23-1](#).



**Figure 23-1. The CAN System**

Each CAN station is connected physically to the CAN bus lines through a transceiver chip. The transceiver is capable of driving the large current needed for the CAN and has current protection against defected CAN or defected stations.

## 23.5 Message Storage

MSCAN08 facilitates a sophisticated message storage system which addresses the requirements of a broad range of network applications.

### 23.5.1 Background

Modern application layer software is built under two fundamental assumptions:

1. Any CAN node is able to send out a stream of scheduled messages without releasing the bus between two messages. Such nodes will arbitrate for the bus right after sending the previous message and will only release the bus in case of lost arbitration.
2. The internal message queue within any CAN node is organized as such that the highest priority message will be sent out first if more than one message is ready to be sent.

Above behavior cannot be achieved with a single transmit buffer. That buffer must be reloaded right after the previous message has been sent. This loading process lasts a definite amount of time and has to be completed within the inter-frame sequence (IFS) to be able to send an uninterrupted stream of messages. Even if this is feasible for limited CAN bus speeds, it requires that the CPU reacts with short latencies to the transmit interrupt.

A double buffer scheme would de-couple the re-loading of the transmit buffers from the actual message being sent and as such reduces the reactivity requirements on the CPU. Problems may arise if the sending of a message would be finished just while the CPU re-loads the second buffer. In that case, no buffer would then be ready for transmission and the bus would be released.

Under all circumstances, at least three transmit buffers are required to meet the first of the above requirements. The MSCAN08 has three transmit buffers.

The second requirement calls for some sort of internal prioritisation which the MSCAN08 implements with the “local priority” concept described in [23.5.2 Receive Structures](#).

### 23.5.2 Receive Structures

The received messages are stored in a 2-stage input first in first out (FIFO). The two message buffers are mapped using a Ping Pong arrangement into a single memory area (see [Figure 23-2](#)). While the background receive buffer (RxBG) is exclusively associated to the MSCAN08, the foreground receive buffer (RxFG) is addressable by the CPU08. This scheme simplifies the handler software, because only one address area is applicable for the receive process.

Each buffer has 13 bytes to store the CAN control bits, the identifier (standard or extended), and the data content (for details, see [See 23.13 Programmer’s Model of Message Storage](#)).

The receiver full flag (RXF) in the MSCAN08 receiver flag register (CRFLG) (see [23.14.5 MSCAN08 Receiver Flag Register](#)) signals the status of the foreground receive buffer. When the buffer contains a correctly received message with matching identifier, this flag is set.

After the MSCAN08 successfully receives a message into the background buffer, it copies the content of RxBG into RxFG<sup>1</sup>, sets the RXF flag, and emits a receive interrupt to the CPU<sup>2</sup>. A new message, which may follow immediately after the IFS field of the CAN frame, will be received into RxBG.

The user’s receive handler has to read the received message from RxFG and to reset the RXF flag to acknowledge the interrupt and to release the foreground buffer.

---

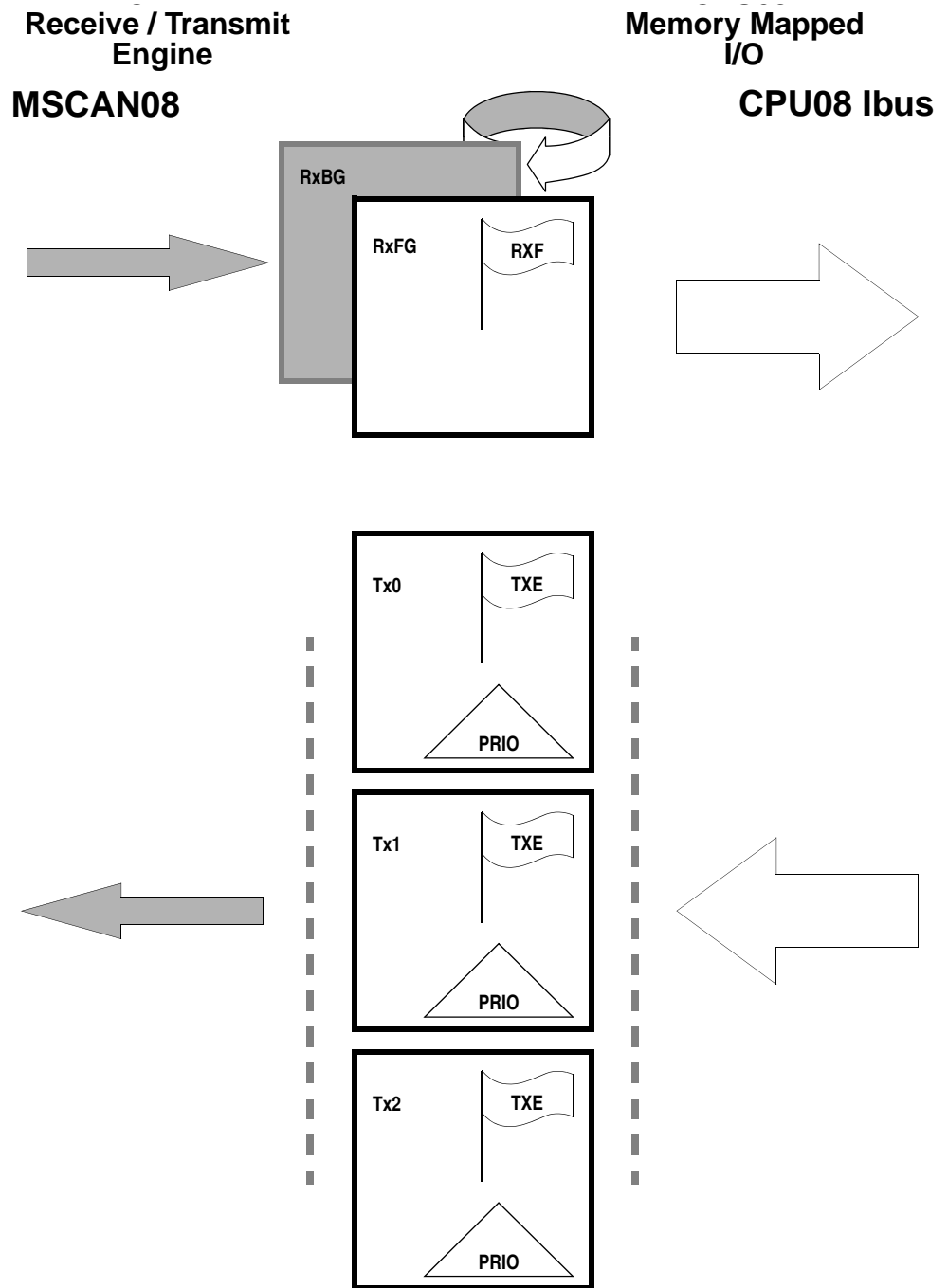
1. Only if the RXF flag is not set.

2. The receive interrupt will occur only if not masked. A polling scheme can be applied on RXF also.



An overrun condition occurs when both the foreground and the background receive message buffers that are filled with correctly received messages and another message is being received from the bus. The latter message will be discarded and an error interrupt with overrun indication will occur if enabled. The over-writing of the background buffer is independent of the identifier filter function. In the overrun situation, the MSCAN08 will stay synchronized to the CAN bus. While it is able to transmit messages, all incoming messages will be discarded.

**NOTE:** *MSCAN08 will receive its own messages into the background receive buffer RxBG but will not overwrite RxFG and will NOT emit a receive interrupt. It also will not acknowledge (ACK) its own messages on the CAN bus. The only exception to this rule is in loop-back mode when MSCAN08 will treat its own messages exactly like all other incoming messages.*



**Figure 23-2. User Model for Message Buffer Organization**

### 23.5.3 Transmit Structures

The MSCAN08 has a triple transmit buffer scheme to allow multiple messages to be set up in advance and to achieve an optimized real-time performance. The three buffers are arranged as shown in [Figure 23-2](#).

All three buffers have a 13-byte data structure similar to the outline of the receive buffers (see [23.13 Programmer's Model of Message Storage](#)). An additional transmit buffer priority register (TBPR) contains an 8-bit “local priority” field (PRIO) (see [23.13.5 Transmit Buffer Priority Registers](#)).

To transmit a message, the CPU08 has to identify an available transmit buffer which is indicated by a set transmit buffer empty (TXE) flag in the MSCAN08 transmitter flag register (CTFLG) (see [23.14.7 MSCAN08 Transmitter Flag Register](#)).

The CPU08 then stores the identifier, the control bits and the data content into one of the transmit buffers. Finally, the buffer has to be flagged ready for transmission by clearing the TXE flag.

The MSCAN08 then will schedule the message for transmission and will signal the successful transmission of the buffer by setting the TXE flag. A transmit interrupt will be emitted<sup>1</sup> when TXE is set and can be used to drive the application software to re-load the buffer.

In case more than one buffer is scheduled for transmission when the CAN bus becomes available for arbitration, the MSCAN08 uses the local priority setting of the three buffers for prioritization. For this purpose, every transmit buffer has an 8-bit local priority field (PRIO). The application software sets this field when the message is set up. The local priority reflects the priority of this particular message relative to the set of messages being emitted from this node. The lowest binary value of the PRIO field is defined as the highest priority.

---

1. The transmit interrupt will occur only if not masked. A polling scheme can be applied on TXE also.

The internal scheduling process takes place whenever the MSCAN08 arbitrates for the bus. This is also the case after the occurrence of a transmission error.

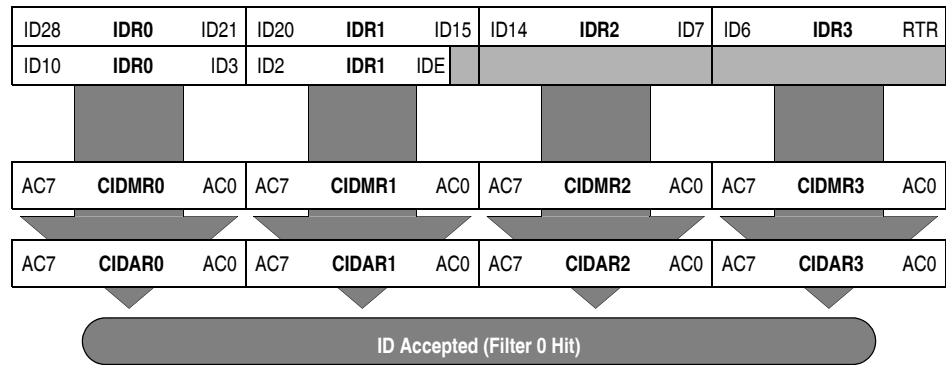
When a high priority message is scheduled by the application software, it may become necessary to abort a lower priority message being set up in one of the three transmit buffers. Because messages that are already under transmission cannot be aborted, the user has to request the abort by setting the corresponding abort request flag (ABTRQ) in the transmission control register (CTCR). The MSCAN08 will then grant the request, if possible, by setting the corresponding abort request acknowledge (ABTAK) and the TXE flag to release the buffer and by emitting a transmit interrupt. The transmit interrupt handler software can tell from the setting of the ABTAK flag whether the message was actually aborted (ABTAK = 1) or sent (ABTAK = 0).

## 23.6 Identifier Acceptance Filter

A flexible, programmable generic identifier acceptance filter has been introduced to reduce the CPU interrupt loading. The filter is programmable to operate in three different modes:

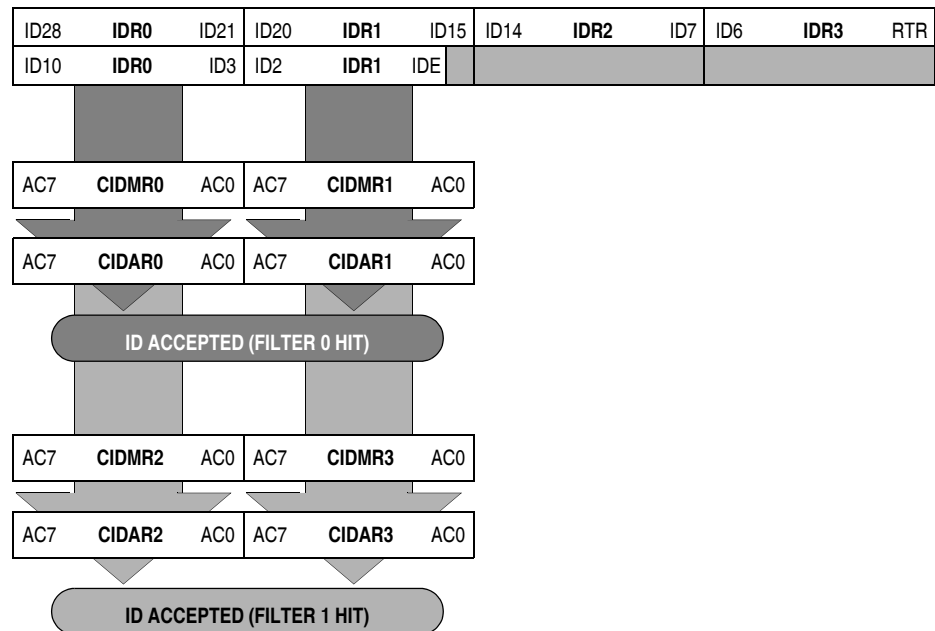
- Single identifier acceptance filter to be applied to the full 29 bits of the identifier and to these bits of the CAN frame: RTR, IDE, and SRR. This mode implements a single filter for a full length CAN 2.0B compliant extended identifier.
- Double identifier acceptance filter to be applied to
  - the 11 bits of the identifier and the RTR bit of CAN 2.0A messages or
  - the 14 most significant bits of the identifier of CAN 2.0B messages
- Quadruple identifier acceptance filter to be applied to the first eight bits of the identifier. This mode implements four independent filters for the first eight bits of a CAN 2.0A compliant standard identifier.

The identifier acceptance registers (CIAR) define the acceptable pattern of the standard or extended identifier (ID10–ID0 or ID28–ID0). Any of these bits can be marked don't care in the identifier mask register (CIMR).



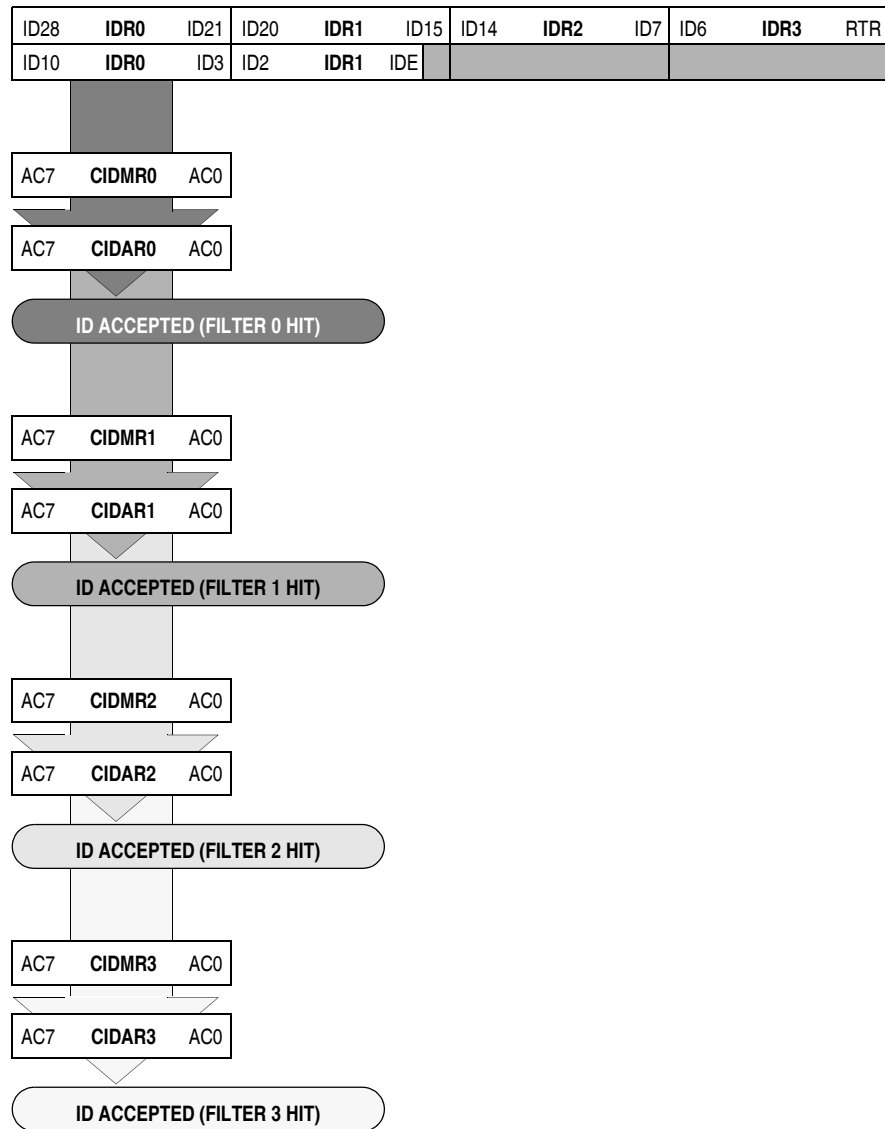
**Figure 23-3. Single 32-Bit Maskable Identifier Acceptance Filter**

The background buffer, RxBG, will be copied into the foreground buffer, RxFG, and the RxF flag will be set only in case of an accepted identifier (an identifier acceptance filter hit). A hit also will cause a receiver interrupt if enabled.



**Figure 23-4. Dual 16-Bit Maskable Acceptance Filters**

A filter hit is indicated to the application software by a set RXF (receiver buffer full flag, see [23.14.5 MSCAN08 Receiver Flag Register](#)) and two bits in the identifier acceptance control register (see [23.14.9 MSCAN08 Identifier Acceptance Control Register \(CIDAC\)](#)). These identifier hit flags (IDHIT1–IDHIT0) clearly identify the filter section that caused the acceptance. They simplify the application software’s task to identify the cause of the receiver interrupt. When more than one hit occurs (two or more filters match), the lower hit has priority.



**Figure 23-5. Quadruple 8-Bit Maskable Acceptance Filters**

## 23.7 Interrupts

The MSCAN08 supports four interrupt vectors mapped onto eleven different interrupt sources, any of which can be individually masked (for details see [23.14.5 MSCAN08 Receiver Flag Register](#) to [23.14.8 MSCAN08 Transmitter Control Register](#)).

- *Transmit Interrupt*: At least one of the three transmit buffers is empty (not scheduled) and can be loaded to schedule a message for transmission. The TXE flags of the empty message buffers are set.
- *Receive Interrupt*: A message has been received successfully and loaded into the foreground receive buffer. This interrupt will be emitted immediately after receiving the EOF symbol. The RXF flag is set.
- *Wakeup Interrupt*: An activity on the CAN bus occurred during MSCAN08 internal sleep mode.
- *Error Interrupt*: An overrun, error, or warning condition occurred. The receiver flag register (CRFLG) will indicate one of the following conditions:
  - *Overrun*: An overrun condition as described in [23.5.2 Receive Structures](#) has occurred.
  - *Receiver Warning*: The receive error counter has reached the CPU Warning limit of 96.
  - *Transmitter Warning*: The transmit error counter has reached the CPU Warning limit of 96.
  - *Receiver Error Passive*: The receive error counter has exceeded the error passive limit of 127 and MSCAN08 has gone to error passive state.
  - *Transmitter Error Passive*: The transmit error counter has exceeded the error passive limit of 127 and MSCAN08 has gone to error passive state.
  - *Bus Off*: The transmit error counter has exceeded 255 and MSCAN08 has gone to bus off state.

## 23.7.1 Interrupt Acknowledge

Interrupts are directly associated with one or more status flags in either the MSCAN08 receiver flag register (CRFLG) or the MSCAN08 transmitter control register (CTCR). Interrupts are pending as long as one of the corresponding flags is set. The flags in the above registers must be reset within the interrupt handler in order to handshake the interrupt. The flags are reset through writing a 1 to the corresponding bit position. A flag cannot be cleared if the respective condition still prevails.

**NOTE:** *Bit manipulation instructions (BSET) shall not be used to clear interrupt flags. The "OR" instruction is the appropriate way to clear selected flags.*

## 23.7.2 Interrupt Vectors

The MSCAN08 supports four interrupt vectors as shown in [Table 23-1](#). The vector addresses are dependent on the chip integration and to be defined. The relative interrupt priority is also integration dependent and to be defined.

**Table 23-1. MSCAN08 Interrupt Vector Addresses**

Function	Source	Local Mask	Global Mask
Wakeup	WUPIF	WUPIE	I Bit
Error Interrupts	RWRNIF	RWRNIE	
	TWRNIF	TWRNIE	
	RERRIF	RERRIE	
	TERRIF	TERRIE	
	BOFFIF	BOFFIE	
	OVRIF	OVRIE	
Receive	RXF	RXFIE	
Transmit	TXE0	TXEIE0	
	TXE1	TXEIE1	
	TXE2	TXEIE2	



## 23.8 Protocol Violation Protection

The MSCAN08 will protect the user from accidentally violating the CAN protocol through programming errors. The protection logic implements these features:

- The receive and transmit error counters cannot be written or otherwise manipulated.
- All registers which control the configuration of the MSCAN08 can not be modified while the MSCAN08 is on-line. The SFTRES bit in the MSCAN08 module control register (see [23.14.1 MSCAN08 Module Control Register](#)) serves as a lock to protect the following registers:
  - MSCAN08 module control register 1 (CMCR1)
  - MSCAN08 bus timing register 0 and 1 (CBTR0 and CBTR1)
  - MSCAN08 identifier acceptance control register (CIDAC)
  - MSCAN08 identifier acceptance registers (CIDAR0–CIDAR3)
  - MSCAN08 identifier mask registers (CIDMR0–CIDMR3)
- The TxCAN pin is forced to recessive if the CPU goes into stop mode.

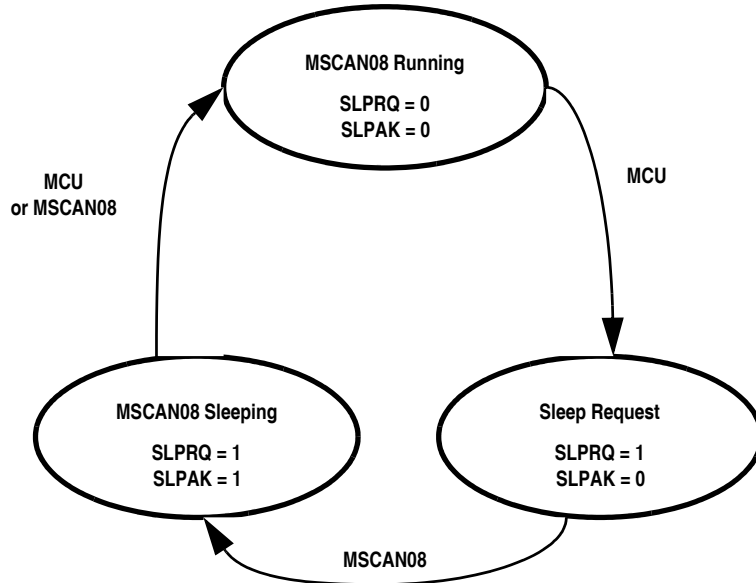
## 23.9 Low-Power Modes

The WAIT and STOP instructions put the MCU in low-power stand-by mode.

### 23.9.1 MSCAN08 Internal Sleep Mode

The CPU can request the MSCAN08 to enter the low-power mode by asserting the SLPRQ bit in the module configuration register (see [Figure 23-6](#)). This causes the MSCAN08 module internal clock to stop unless the module is active (such as receiving a message). The SLPK bit indicates whether the MSCAN08 successfully went into sleep mode. The application software should use this flag as a handshake indication for the request to go into sleep mode. If not set after the request, the

MSCAN08 is active and has not yet entered sleep mode. No wakeup interrupt will occur in that case.



**Figure 23-6. Sleep Request/Acknowledge Cycle**

When in sleep mode, the MSCAN08 stops its own clocks, leaving the MCU in normal run mode.

The MSCAN08 will leave sleep mode (wakeup) when bus activity occurs or when the MCU clears the SLPRQ bit.

The TxCAN pin will stay in a recessive state while the MSCAN08 is in internal sleep mode.

**NOTE:** *The MCU cannot clear the SLPRQ bit before the MSCAN08 is in sleep mode (SLPAK = 1).*

### 23.9.2 CPU Wait Mode

The MSCAN08 module remains active during CPU wait mode. The MSCAN08 will stay synchronized to the CAN bus and will generate enabled transmit, receive, and error interrupts to the CPU. Any such interrupt will bring the MCU out of wait mode.

### 23.9.3 CPU Stop Mode

A CPU STOP instruction will stop the crystal oscillator, thus shutting down all system clocks. The user is responsible for ensuring that the MSCAN08 is not active when the CPU goes into stop mode. To protect the CAN bus system from fatal consequences of violations to this rule, the MSCAN08 will drive the TxCAN pin into a recessive state.

The recommended procedure is to bring the MSCAN08 into sleep mode before the CPU STOP instruction is executed.

### 23.9.4 Programmable Wakeup Function

The MSCAN08 can be programmed to apply a low-pass filter function to the RxCAN input line while in internal sleep mode (see information on control bit WUPM in [23.14.1 MSCAN08 Module Control Register](#)). This feature can be used to protect the MSCAN08 from wakeup due to short glitches on the CAN bus lines. Such glitches can result from electromagnetic interference within noisy environments.

## 23.10 Timer Link

The MSCAN08 will generate a timer signal whenever a valid frame has been received. Because the CAN specification defines a frame to be valid if no errors occurred before the EOF field has been transmitted successfully, the timer signal will be generated right after the EOF. A pulse of one bit time is generated. As the MSCAN08 receiver engine also receives the frames being sent by itself, a timer signal also will be generated after a successful transmission.

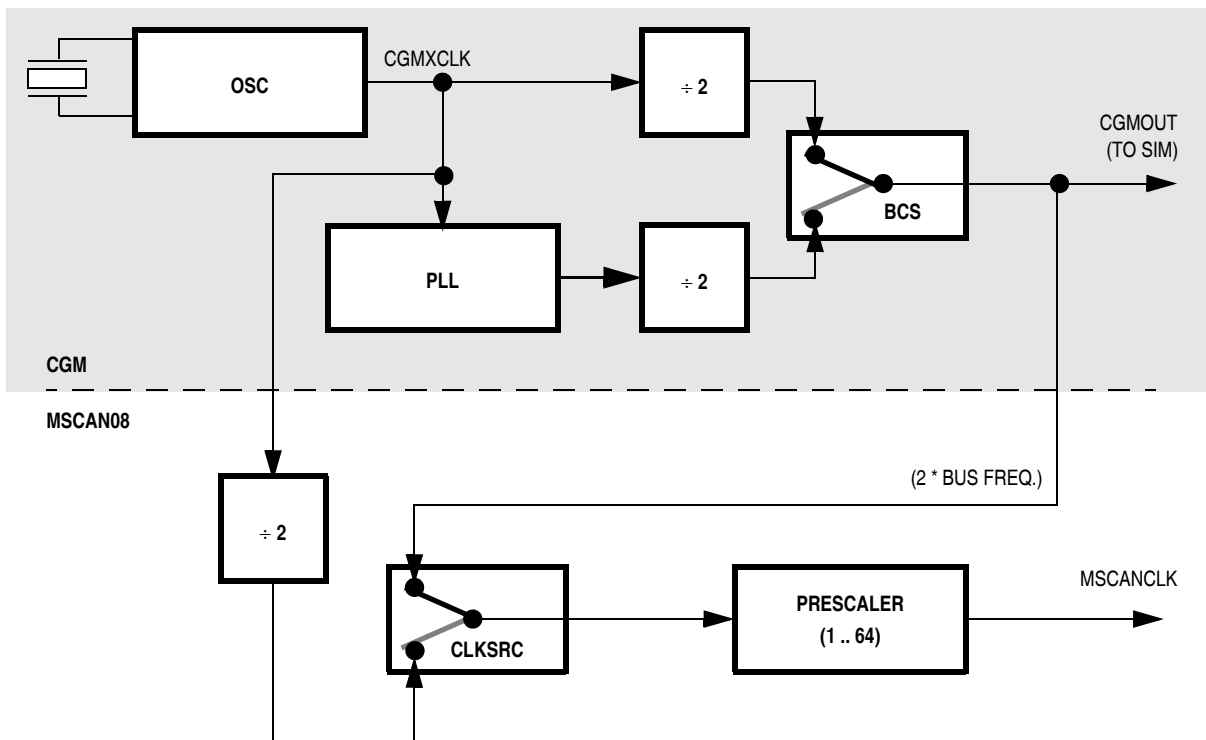
The previously described timer signal can be routed into the on-chip timer interface module (TIM). Under the control of the timer link enable (TLNKEN) bit in the CMCR0 will this signal be connected to the timer n channel m input.

**NOTE:** *The timer channel being used for the timer link is integration dependent.*

After timer n has been programmed to capture rising edge events, it can be used to generate 16-bit time stamps which can be stored under software control with the received message.

## 23.11 Clock System

**Figure 23-7** shows the structure of the MSCAN08 clock generation circuitry and its interaction with the clock generation module (CGM). With this flexible clocking scheme the MSCAN08 is able to handle CAN bus rates ranging from 10 kbps up to 1 Mbps.



**Figure 23-7. Clocking Scheme**

The clock source flag (CLKSRC) in the MSCAN08 module control register (CMCR1) (see [23.14.1 MSCAN08 Module Control Register](#)) defines whether the MSCAN08 is connected to the output of the crystal oscillator or to the PLL output.

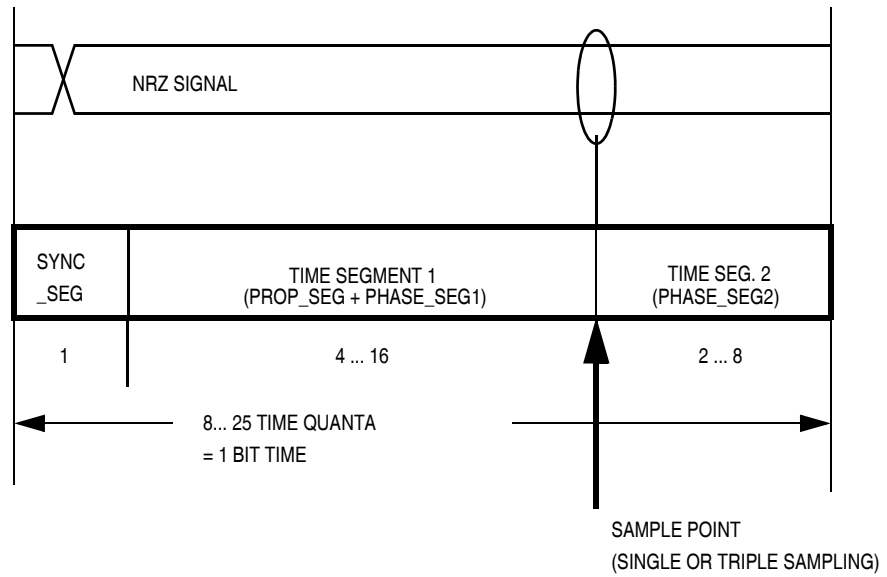
The MSCAN08 clock is used to generate the atomic unit of time handled by the MSCAN08: the time quantum. A bit time is subdivided into three segments defined here. For further explanation of the underlying concepts please refer to ISO/DIS 11519-1, Section 10.3.

- SYNC\_SEG: This segment has a fixed length of one time quantum. Signal edges are expected to happen within this section.
- Time segment 1: This segment includes the PROP\_SEG and the PHASE\_SEG1 of the CAN standard. It can be programmed by setting the parameter TSEG1 to consist of 4 to 16 time quanta.
- Time segment 2: This segment represents PHASE\_SEG2 of the CAN standard. It can be programmed by setting the TSEG2 parameter to be 2 to 8 time quanta long.

The synchronization jump width (SJW) can be programmed in a range of 1 to 4 time quanta by setting the SJW parameter.

The above parameters can be set by programming the bus timing registers, CBTR0–CBTR1 (see [23.14.3 MSCAN08 Bus Timing Register 0](#) and [23.14.4 MSCAN08 Bus Timing Register 1](#)).

The user is responsible for making sure that the bit time settings comply with the CAN standard. [Table 23-2](#) gives an overview on the CAN conforming segment settings and the related parameter values.



**Figure 23-8. Segments within the Bit Time**

**Table 23-2. CAN Standard Compliant Bit Time Segment Settings**

Time Segment 1	TSEG1	Time Segment 2	TSEG2	Synchron. Jump Width	SJW
5 .. 10	4 .. 9	2	1	1 .. 2	0 .. 1
4 .. 11	3 .. 10	3	2	1 .. 3	0 .. 2
5 .. 12	4 .. 11	4	3	1 .. 4	0 .. 3
6 .. 13	5 .. 12	5	4	1 .. 4	0 .. 3
7 .. 14	6 .. 13	6	5	1 .. 4	0 .. 3
8 .. 15	7 .. 14	7	6	1 .. 4	0 .. 3
9 .. 16	8 .. 15	8	7	1 .. 4	0 .. 3

## 23.12 Memory Map

The MSCAN08 occupies 128 bytes in the CPU08 memory space. The absolute mapping is implementation dependent with the base address being a multiple of 128. The background receive buffer can be read in only test mode.

Addr	Register Name
_____	

**Figure 23-9. MSCAN08 Memory Map**

**NOTE:** *Due to design requirements, the absolute addresses and bit locations may change with later revisions of this specification.*

## 23.13 Programmer's Model of Message Storage

This section details the organization of the receive and transmit message buffers and the associated control registers. For reasons of programmer interface simplification, the receive and transmit message buffers have the same outline. Each message buffer allocates 16 bytes

in the memory map containing a 13-byte data structure. An additional transmit buffer priority register (TBPR) is defined for the transmit buffers.

Addr	Register Name
\$05b0	IDENTIFIER REGISTER 0
\$05b1	IDENTIFIER REGISTER 1
\$05b2	IDENTIFIER REGISTER 2
\$05b3	IDENTIFIER REGISTER 3
\$05b4	DATA SEGMENT REGISTER 0
\$05b5	DATA SEGMENT REGISTER 1
\$05b6	DATA SEGMENT REGISTER 2
\$05b7	DATA SEGMENT REGISTER 3
\$05b8	DATA SEGMENT REGISTER 4
\$05b9	DATA SEGMENT REGISTER 5
\$05bA	DATA SEGMENT REGISTER 6
\$05bB	DATA SEGMENT REGISTER 7
\$05bC	DATA LENGTH REGISTER
\$05bD	TRANSMIT BUFFER PRIORITY REGISTER <sup>(1)</sup>
\$05bE	UNUSED
\$05bF	UNUSED

1. Not applicable for receive buffers

**Figure 23-10. Message Buffer Organization**

### 23.13.1 Message Buffer Outline

**Figure 23-11** shows the common 13-byte data structure of receive and transmit buffers for extended identifiers. The mapping of standard identifiers into the IDR registers is shown in **Figure 23-12**. All bits of the 13-byte data structure are undefined out of reset.




### 23.13.2 Identifier Registers

The identifiers consist of either 11 bits (ID10–ID0) for the standard, or 29 bits (ID28–ID0) for the extended format. ID10/28 is the most significant bit and is transmitted first on the bus during the arbitration procedure. The highest priority of an identifier is defined as the smallest binary number.

SRR — Substitute Remote Request

This fixed recessive bit is used only in extended format. It must be set to 1 by the user for transmission buffers and will be stored as received on the CAN bus for receive buffers.


Addr.	Register		Bit 7	6	5	4	3	2	1	Bit 0
\$05b0	IDR0	Read:	ID28	ID27	ID26	ID25	ID24	ID23	ID22	ID21
		Write:								
\$05b1	IDR1	Read:	ID20	ID19	ID18	SRR (1)	IDE (1)	ID17	ID16	ID15
		Write:								
\$05b2	IDR2	Read:	ID14	ID13	ID12	ID11	ID10	ID9	ID8	ID7
		Write:								
\$05b3	IDR3	Read:	ID6	ID5	ID4	ID3	ID2	ID1	ID0	RTR
		Write:								
\$05b4	DSR0	Read:	DB7	DB6	DB5	DB4	DB3	DB2	DB1	DB0
		Write:								
\$05b5	DSR1	Read:	DB7	DB6	DB5	DB4	DB3	DB2	DB1	DB0
		Write:								
\$05b6	DSR2	Read:	DB7	DB6	DB5	DB4	DB3	DB2	DB1	DB0
		Write:								
\$05b7	DSR3	Read:	DB7	DB6	DB5	DB4	DB3	DB2	DB1	DB0
		Write:								
\$05b8	DSR4	Read:	DB7	DB6	DB5	DB4	DB3	DB2	DB1	DB0
		Write:								
\$05b9	DSR5	Read:	DB7	DB6	DB5	DB4	DB3	DB2	DB1	DB0
		Write:								
\$05bA	DSR6	Read:	DB7	DB6	DB5	DB4	DB3	DB2	DB1	DB0
		Write:								
\$05bB	DSR7	Read:	DB7	DB6	DB5	DB4	DB3	DB2	DB1	DB0
		Write:								
\$05bC	DLR	Read:					DLC3	DLC2	DLC1	DLC0
		Write:								

 = Unimplemented

**Figure 23-11. Receive/Transmit Message Buffer Extended Identifier (IDRn)**



Addr.	Register		Bit 7	6	5	4	3	2	1	Bit 0
\$05b0	IDR0	Read:	ID10	ID9	ID8	ID7	ID6	ID5	ID4	ID3
		Write:								
\$05b1	IDR1	Read:	ID2	ID1	ID0	RTR	IDE(0)			
		Write:								
\$05b2	IDR2	Read:								
		Write:								
\$05b3	IDR3	Read:								
		Write:								

 = Unimplemented

**Figure 23-12. Standard Identifier Mapping**

#### IDE — ID Extended

This flag indicates whether the extended or standard identifier format is applied in this buffer. In case of a receive buffer, the flag is set as being received and indicates to the CPU how to process the buffer identifier registers. In case of a transmit buffer, the flag indicates to the MSCAN08 what type of identifier to send.

- 1 = Extended format, 29 bits
- 0 = Standard format, 11 bits

#### RTR — Remote Transmission Request

This flag reflects the status of the remote transmission request bit in the CAN frame. In case of a receive buffer, it indicates the status of the received frame and allows the transmission of an answering frame in software to be supported. In case of a transmit buffer, this flag defines the setting of the RTR bit to be sent.

- 1 = Remote frame
- 0 = Data frame

## 23.13.3 Data Length Register (DLR)

This register keeps the data length field of the CAN frame.

### DLC3–DLC0 — Data Length Code Bits

The data length code contains the number of bytes (data byte count) of the respective message. At transmission of a remote frame, the data length code is transmitted as programmed while the number of transmitted bytes is always 0. The data byte count ranges from 0 to 8 for a data frame. [Table 23-3](#) shows the effect of setting the DLC bits.

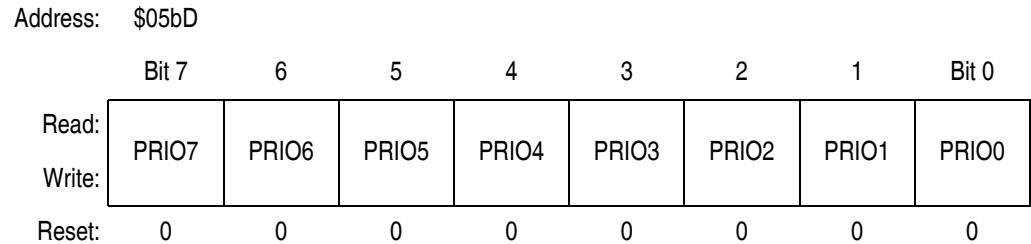
**Table 23-3. Data Length Codes**

Data Length Code				Data Byte Count
DLC3	DLC2	DLC1	DLC0	
0	0	0	0	0
0	0	0	1	1
0	0	1	0	2
0	0	1	1	3
0	1	0	0	4
0	1	0	1	5
0	1	1	0	6
0	1	1	1	7
1	0	0	0	8

## 23.13.4 Data Segment Registers (DSRn)

The eight data segment registers contain the data to be transmitted or received. The number of bytes to be transmitted or being received is determined by the data length code in the corresponding DLR.

### 23.13.5 Transmit Buffer Priority Registers



**Figure 23-13. Transmit Buffer Priority Register (TBPR)**

#### PRI07–PRI00 — Local Priority

This field defines the local priority of the associated message buffer. The local priority is used for the internal prioritization process of the MSCAN08 and is defined to be highest for the smallest binary number. The MSCAN08 implements the following internal prioritization mechanism:

- All transmission buffers with a cleared TXE flag participate in the prioritization right before the SOF is sent.
- The transmission buffer with the lowest local priority field wins the prioritization.
- In case more than one buffer has the same lowest priority, the message buffer with the lower index number wins.

**NOTE:** *To ensure data integrity, no registers of the transmit buffers shall be written while the associated TXE flag is cleared.*

*To ensure data integrity, no registers of the receive buffer shall be read while the RXF flag is cleared.*

## 23.14 Programmer's Model of Control Registers

The programmer's model has been laid out for maximum simplicity and efficiency. **Figure 23-14** gives an overview on the control register block of the MSCAN08.

Addr	Register	Bit 7	6	5	4	3	2	1	Bit 0	
\$0500	CMCR0	Read:	0	0	0	SYNCH	TLNKEN	SLPAK	SLPRQ	SFTRES
		Write:								
		Reset:	0	0	0	0	0	0	0	1
\$0501	CMCR1	Read:	0	0	0	0	0	LOOPB	WUPM	CLKSRC
		Write:								
		Reset:	0	0	0	0	0	0	0	0
\$0502	CBTR0	Read:	SJW1	SJW0	BRP5	BRP4	BRP3	BRP2	BRP1	BRP0
		Write:								
		Reset:	0	0	0	0	0	0	0	0
\$0503	CBTR1	Read:	SAMP	TSEG22	TSEG21	TSEG20	TSEG13	TSEG12	TSEG11	TSEG10
		Write:								
		Reset:	0	0	0	0	0	0	0	0
\$0504	CRFLG	Read:	WUPIF	RWRNIF	TWRNIF	RERRIF	TERRIF	BOFFIF	OVRIF	RXF
		Write:								
		Reset:	0	0	0	0	0	0	0	0
\$0505	CRIER	Read:	WUPIE	RWRNIE	TWRNIE	RERRIE	TERRIE	BOFFIE	OVRIE	RXFIE
		Write:								
		Reset:	0	0	0	0	0	0	0	0
\$0506	CTFLG	Read:	0	ABTAK2	ABTAK1	ABTAK0	0	TXE2	TXE1	TXE0
		Write:								
		Reset:	0	0	0	0	0	1	1	1
\$0507	CTCR	Read:	0	ABTRQ2	ABTRQ1	ABTRQ0	0	TXEIE2	TXEIE1	TXEIE0
		Write:								
		Reset:	0	0	0	0	0	0	0	0

= Unimplemented
 R = Reserved

**Figure 23-14. MSCAN08 Control Register Structure**



Addr	Register	Bit 7	6	5	4	3	2	1	Bit 0	
\$0508	CIDAC	Read:	0	0	IDAM1	IDAM0	0	0	IDHIT1	IDHIT0
		Write:								
		Reset:	0	0	0	0	0	0	0	0
\$0509	Reserved	Read:	R	R	R	R	R	R	R	
\$050E	CRXERR	Read:	RXERR7	RXERR6	RXERR5	RXERR4	RXERR3	RXERR2	RXERR1	RXERR0
		Write:								
		Reset:	0	0	0	0	0	0	0	0
\$050F	CTXERR	Read:	TXERR7	TXERR6	TXERR5	TXERR4	TXERR3	TXERR2	TXERR1	TXERR0
		Write:								
		Reset:	0	0	0	0	0	0	0	0
\$0510	CIDAR0	Read:	AC7	AC6	AC5	AC4	AC3	AC2	AC1	AC0
		Write:								
		Reset:	Unaffected by Reset							
\$0511	CIDAR1	Read:	AC7	AC6	AC5	AC4	AC3	AC2	AC1	AC0
		Write:								
		Reset:	Unaffected by Reset							
\$0512	CIDAR2	Read:	AC7	AC6	AC5	AC4	AC3	AC2	AC1	AC0
		Write:								
		Reset:	Unaffected by Reset							
\$0513	CIDAR3	Read:	AC7	AC6	AC5	AC4	AC3	AC2	AC1	AC0
		Write:								
		Reset:	Unaffected by Reset							
\$0514	CIDMR0	Read:	AM7	AM6	AM5	AM4	AM3	AM2	AM1	AM0
		Write:								
		Reset:	Unaffected by Reset							
\$0515	CIDMR1	Read:	AM7	AM6	AM5	AM4	AM3	AM2	AM1	AM0
		Write:								
		Reset:	Unaffected by Reset							

= Unimplemented
 R = Reserved

**Figure 23-14. MSCAN08 Control Register Structure (Continued)**

Addr	Register	Bit 7	6	5	4	3	2	1	Bit 0	
\$0516	CIDMR2	Read:	AM7	AM6	AM5	AM4	AM3	AM2	AM1	AM0
		Write:	AM7	AM6	AM5	AM4	AM3	AM2	AM1	AM0
		Reset:	Unaffected by Reset							
\$0517	CIDMR3	Read:	AM7	AM6	AM5	AM4	AM3	AM2	AM1	AM0
		Write:	AM7	AM6	AM5	AM4	AM3	AM2	AM1	AM0
		Reset:	Unaffected by Reset							

= Unimplemented     
 R = Reserved

**Figure 23-14. MSCAN08 Control Register Structure (Continued)**

### 23.14.1 MSCAN08 Module Control Register

Address: \$0500

	Bit 7	6	5	4	3	2	1	Bit 0
Read:	0	0	0	SYNCH	TLNKEN	SLPAK	SLPRQ	SFTRES
Write:					TLNKEN		SLPRQ	SFTRES
Reset:	0	0	0	0	0	0	0	1

= Unimplemented

**Figure 23-15. Module Control Register 0 (CMCR0)**

#### SYNCH — Synchronized Status

This bit indicates whether the MSCAN08 is synchronized to the CAN bus and as such can participate in the communication process.

- 1 = MSCAN08 synchronized to the CAN bus
- 0 = MSCAN08 not synchronized to the CAN bus

#### TLNKEN — Timer Enable

This flag is used to establish a link between the MSCAN08 and the on-chip timer (see [23.10 Timer Link](#)).

- 1 = The MSCAN08 timer signal output is connected to the timer.
- 0 = No connection

#### SLPAK — Sleep Mode Acknowledge

This flag indicates whether the MSCAN08 is in module internal sleep mode. It shall be used as a handshake for the sleep mode request (see [23.9.1 MSCAN08 Internal Sleep Mode](#)).

- 1 = Sleep – MSCAN08 in internal sleep mode
- 0 = Wakeup – MSCAN08 will function normally

#### SLPRQ — Sleep Request, Go to Internal Sleep Mode

This flag allows a request for the MSCAN08 to go into an internal power-saving mode (see [23.9.1 MSCAN08 Internal Sleep Mode](#)).

- 1 = Sleep — The MSCAN08 will go into internal sleep mode if and as long as there is no activity on the bus.
- 0 = Wakeup — The MSCAN08 will function normally. If SLPAK is cleared by the CPU, then the MSCAN08 will wake up, but will not issue a wakeup interrupt.

#### SFTRES — Soft Reset

When this bit is set by the CPU, the MSCAN08 immediately enters the soft reset state. Any ongoing transmission or reception is aborted and synchronization to the bus is lost.

These registers will go into the same state as out of hard reset: CMCR0, CRFLG, CRIER, CTFLG, and CTCR.

The registers CMCR1, CBTR0, CBTR1, CIDAC, CIDAR0–CIDAR3, and CIDMR0–CIDMR3 can only be written by the CPU when the MSCAN08 is in soft reset state. The values of the error counters are not affected by soft reset.

When this bit is cleared by the CPU, the MSCAN08 will try to synchronize to the CAN bus. If the MSCAN08 is not in bus-off state, it will be synchronized after 11 recessive bits on the bus; if the MSCAN08 is in bus-off state, it continues to wait for 128 occurrences of 11 recessive bits.

- 1 = MSCAN08 in soft reset state
- 0 = Normal operation

## 23.14.2 MSCAN08 Module Control Register

Address: \$0501

	Bit 7	6	5	4	3	2	1	Bit 0
Read:	0	0	0	0	0	LOOPB	WUPM	CLKSRC
Write:								
Reset:	0	0	0	0	0	0	0	0

= Unimplemented

**Figure 23-16. Module Control Register (CMCR1)**

### LOOPB — Loop Back Self-Test Mode

When this bit is set, the MSCAN08 performs an internal loop back which can be used for self-test operation and the bit stream output of the transmitter is fed back to the receiver. The RxCAN input pin is ignored and the TxCAN output goes to the recessive state (1). Note that in this state, the MSCAN08 ignores the ACK bit to ensure proper reception of its own message and will treat messages being received while in transmission as received messages from remote nodes.

- 1 = Activate loop back self-test mode
- 0 = Normal operation

### WUPM — Wakeup Mode

This flag defines whether the integrated low-pass filter is applied to protect the MSCAN08 from spurious wakeups (see [23.9.4 Programmable Wakeup Function](#)).

- 1 = MSCAN08 will wake up the CPU only in cases of a dominant pulse on the bus which has a length of at least  $t_{wup}$ .
- 0 = MSCAN08 will wake up the CPU after any recessive to dominant edge on the CAN bus.

### CLKSRC — Clock Source

This flag defines which clock source the MSCAN08 module is driven from (see [23.11 Clock System](#)).

- 1 = The MSCAN08 clock source is CGMOUT (see [Figure 23-7](#)).
- 0 = The MSCAN08 clock source is CGMXCLK/2 (see [Figure 23-7](#)).

**NOTE:** *The CMCR1 register can be written only if the SFTRES bit in the MSCAN08 module control register is set.*

### 23.14.3 MSCAN08 Bus Timing Register 0

Address: \$0502

	Bit 7	6	5	4	3	2	1	Bit 0
Read:	SJW1	SJW0	BRP5	BRP4	BRP3	BRP2	BRP1	BRP0
Write:								
Reset:	0	0	0	0	0	0	0	0

**Figure 23-17. Bus Timing Register 0 (CBTR0)**

#### SJW1 and SJW0 — Synchronization Jump Width

The synchronization jump width (SJW) defines the maximum number of system clock ( $t_{SCL}$ ) cycles by which a bit may be shortened, or lengthened, to achieve resynchronization on data transitions on the bus (see [Table 23-4](#)).

**Table 23-4. Synchronization Jump Width**

SJW1	SJW0	Synchronization Jump Width
0	0	1 $t_{SCL}$ cycle
0	1	2 $t_{SCL}$ cycles
1	0	3 $t_{SCL}$ cycles
1	1	4 $t_{SCL}$ cycles

#### BRP5–BRP0 — Baud Rate Prescaler

These bits determine the MSCAN08 system clock cycle time ( $t_{SCL}$ ), which is used to build up the individual bit timing, according to [Table 23-5](#).

**Table 23-5. Baud Rate Prescaler**

BRP5	BRP4	BRP3	BRP2	BRP1	BRP0	Prescaler Value (P)
0	0	0	0	0	0	1
0	0	0	0	0	1	2
0	0	0	0	1	0	3
0	0	0	0	1	1	4
:	:	:	:	:	:	:
:	:	:	:	:	:	:
1	1	1	1	1	1	64

**NOTE:** *The CBTR0 register can be written only if the SFTRES bit in the MSCAN08 module control register is set.*

## 23.14.4 MSCAN08 Bus Timing Register 1

Address: \$0503

	Bit 7	6	5	4	3	2	1	Bit 0
Read:	SAMP	TSEG22	TSEG21	TSEG20	TSEG13	TSEG12	TSEG11	TSEG10
Write:								
Reset:	0	0	0	0	0	0	0	0

**Figure 23-18. Bus Timing Register 1 (CBTR1)**

### SAMP — Sampling

This bit determines the number of serial bus samples to be taken per bit time. If set, three samples per bit are taken, the regular one (sample point) and two preceding samples, using a majority rule. For higher bit rates, SAMP should be cleared, which means that only one sample will be taken per bit.

1 = Three samples per bit

0 = One sample per bit

### TSEG22–TSEG10 — Time Segment

Time segments within the bit time fix the number of clock cycles per bit time and the location of the sample point.

**Table 23-6. Time Segment Syntax**

Time Segment	Action
SYNC_SEG	System expects transitions to occur on the bus during this period.
Transmit point	A node in transmit mode will transfer a new value to the CAN bus at this point.
Sample point	A node in receive mode will sample the bus at this point. If the three samples per bit option is selected then this point marks the position of the third sample.

Time segment 1 (TSEG1) and time segment 2 (TSEG2) are programmable as shown in [Table 23-7](#).

**Table 23-7. Time Segment Values**

TSEG13	TSEG12	TSEG11	TSEG10	Time Segment 1	TSEG22	TSEG21	TSEG20	Time Segment 2
0	0	0	0	1 $t_{SCL}$ Cycle	0	0	0	1 $t_{SCL}$ Cycle
0	0	0	1	2 $t_{SCL}$ Cycles	0	0	1	2 $t_{SCL}$ Cycles
0	0	1	0	3 $t_{SCL}$ Cycles	.	.	.	.
0	0	1	1	4 $t_{SCL}$ Cycles	.	.	.	.
.	.	.	.	.	1	1	1	8 $t_{SCL}$ Cycles
.	.	.	.	.				
1	1	1	1	16 $t_{SCL}$ Cycles				

The bit time is determined by the oscillator frequency, the baud rate prescaler, and the number of bus clock cycles ( $t_{SCL}$ ) per bit as shown in [Table 23-7](#).

**NOTE:** *The CBTR1 register can be written only if the SFTRES bit in the MSCAN08 module control register is set.*

## 23.14.5 MSCAN08 Receiver Flag Register

All bits of this register are read and clear only. A flag can be cleared by writing a 1 to the corresponding bit position. A flag can be cleared only when the condition which caused the setting is valid no more. Writing a 0 has no effect on the flag setting. Every flag has an associated interrupt enable flag in the CRIER register. A hard or soft reset will clear the register.

Address: \$0504

	Bit 7	6	5	4	3	2	1	Bit 0
Read:	WUPIF	RWRNIF	TWRNIF	RERRIF	TERRIF	BOFFIF	OVRIF	RXF
Write:								
Reset:	0	0	0	0	0	0	0	0

**Figure 23-19. Receiver Flag Register (CRFLG)**

### WUPIF — Wakeup Interrupt Flag

If the MSCAN08 detects bus activity while it is asleep, it clears the SLPKSLPAK bit in the CMCR0 register; the WUPIF bit will then be set. If not masked, a wakeup interrupt is pending while this flag is set.

1 = MSCAN08 has detected activity on the bus and requested wakeup.

0 = No wakeup interrupt has occurred.

### RWRNIF — Receiver Warning Interrupt Flag

This bit will be set when the MSCAN08 went into warning status because the receive error counter was in the range of 96 to 127. If not masked, an error interrupt is pending while this flag is set.

1 = MSCAN08 went into warning status.

0 = No warning interrupt has occurred.

### TWRNIF — Transmitter Warning Interrupt Flag

This bit will be set when the MSCAN08 went into warning status because the transmit error counter was in the range of 96 to 127. If not masked, an error interrupt is pending while this flag is set.

1 = MSCAN08 went into warning status.

0 = No warning interrupt has occurred.



#### RERRIF — Receiver Error Passive Interrupt Flag

This bit will be set when the MSCAN08 went into error passive status because the receive error counter exceeded 127. If not masked, an Error interrupt is pending while this flag is set.

- 1 = MSCAN08 went into error passive status.
- 0 = No warning interrupt has occurred.

#### TERRIF — Transmitter Error Passive Interrupt Flag

This bit will be set when the MSCAN08 went into error passive status due to the Transmit Error counter exceeded 127. If not masked, an Error interrupt is pending while this flag is set.

- 1 = MSCAN08 went into error passive status.
- 0 = No warning interrupt has occurred.

#### BOFFIF — Bus-Off Interrupt Flag

This bit will be set when the MSCAN08 went into bus-off status, because the transmit error counter exceeded 255. If not masked, an Error interrupt is pending while this flag is set.

- 1 = MSCAN08 went into warning status.
- 0 = No warning interrupt has occurred.

#### OVRIF — Overrun Interrupt Flag

This bit will be set when a data overrun condition occurred. If not masked, an error interrupt is pending while this flag is set.

- 1 = A data overrun has been detected.
- 0 = No data overrun has occurred.

#### RXF — Receive Buffer Full

The RXF flag is set by the MSCAN08 when a new message is available in the foreground receive buffer. This flag indicates whether the buffer is loaded with a correctly received message. After the CPU has read that message from the receive buffer the RXF flag must be handshaked to release the buffer. A set RXF flag prohibits the exchange of the background receive buffer into the foreground buffer. In that case the MSCAN08 will signal an overload condition. If not masked, a receive interrupt is pending while this flag is set.

- 1 = The receive buffer is full. A new message is available.
- 0 = The receive buffer is released (not full).

## 23.14.6 MSCAN08 Receiver Interrupt Enable Register

Address: \$0505

	Bit 7	6	5	4	3	2	1	Bit 0
Read:	WUPIE	RWRNIE	TWRNIE	RERRIE	TERRIE	BOFFIE	OVRIE	RXFIE
Write:								
Reset:	0	0	0	0	0	0	0	0

**Figure 23-20. Receiver Interrupt Enable Register (CRIER)**

**WUPIE** — Wakeup Interrupt Enable

1 = A wakeup event will result in a wakeup interrupt.

0 = No interrupt will be generated from this event.

**RWRNIE** — Receiver Warning Interrupt Enable

1 = A receiver warning status event will result in an error interrupt.

0 = No interrupt will be generated from this event.

**TWRNIE** — Transmitter Warning Interrupt Enable

1 = A transmitter warning status event will result in an error interrupt.

0 = No interrupt will be generated from this event.

**RERRIE** — Receiver Error Passive Interrupt Enable

1 = A receiver error passive status event will result in an error interrupt.

0 = No interrupt will be generated from this event.

**TERRIE** — Transmitter Error Passive Interrupt Enable

1 = A transmitter error passive status event will result in an error interrupt.

0 = No interrupt will be generated from this event.

**BOFFIE** — Bus-Off Interrupt Enable

1 = A bus-off event will result in an error interrupt.

0 = No interrupt will be generated from this event.

**OVRIE — Overrun Interrupt Enable**

- 1 = An overrun event will result in an error interrupt.
- 0 = No interrupt will be generated from this event.

**RXFIE — Receiver Full Interrupt Enable**

- 1 = A receive buffer full (successful message reception) event will result in a receive interrupt.
- 0 = No interrupt will be generated from this event.

**23.14.7 MSCAN08 Transmitter Flag Register**

All bits of this register are read and clear only. A flag can be cleared by writing a 1 to the corresponding bit position. Writing a 0 has no effect on the flag setting. Every flag has an associated interrupt enable flag in the CTCR register. A hard or soft reset will clear the register.

Address: \$0506 5

	Bit 7	6	5	4	3	2	1	Bit 0
Read:	0	ABTAK2	ABTAK1	ABTAK0	0	TXE2	TXE1	TXE0
Write:								
Reset:	0	0	0	0	0	1	1	1

= Unimplemented

**Figure 23-21. Transmitter Flag Register (CTFLG)**

**ABTAK2–ABTAK0 — Abort Acknowledge**

This flag acknowledges that a message has been aborted due to a pending abort request from the CPU. After a particular message buffer has been flagged empty, this flag can be used by the application software to identify whether the message has been aborted successfully or has been sent. The flag is reset implicitly whenever the associated TXE flag is set to 0.

- 1 = The message has been aborted.
- 0 = The message has not been aborted, thus has been sent out.

## TXE2–TXE0 — Transmitter Empty

This flag indicates that the associated transmit message buffer is empty, thus not scheduled for transmission. The CPU must handshake (clear) the flag after a message has been set up in the transmit buffer and is due for transmission. The MSCAN08 will set the flag after the message has been sent successfully. The flag also will be set by the MSCAN08 when the transmission request was successfully aborted due to a pending abort request (see [23.13.5 Transmit Buffer Priority Registers](#)). If not masked, a receive interrupt is pending while this flag is set.

A reset of this flag also will reset the abort acknowledge (ABTAK) and the abort request (ABTRQ, (see [23.14.8 MSCAN08 Transmitter Control Register](#)) flags of the particular buffer.

- 1 = The associated message buffer is empty (not scheduled).
- 0 = The associated message buffer is full (loaded with a message due for transmission).

### 23.14.8 MSCAN08 Transmitter Control Register

Address: \$0507

	Bit 7	6	5	4	3	2	1	Bit 0
Read:	0	ABTRQ2	ABTRQ1	ABTRQ0	0	TXEIE2	TXEIE1	TXEIE0
Write:								
Reset:	0	0	0	0	0	0	0	0

= Unimplemented

**Figure 23-22. Transmitter Control Register (CTCR)**

#### ABTRQ2–ABTRQ0 — Abort Request

The CPU sets this flag to request that an already scheduled message buffer (TXE = 0) be aborted. The MSCAN08 will grant the request when the message is not already under transmission. When a message is aborted the associated TXE and the abort acknowledge flag (ABTAK) (see [23.14.7 MSCAN08 Transmitter Flag Register](#)) will be set and an TXE interrupt will occur if enabled. The CPU cannot reset this flag. The flag is reset implicitly whenever the associated TXE flag is set.

1 = Abort request pending

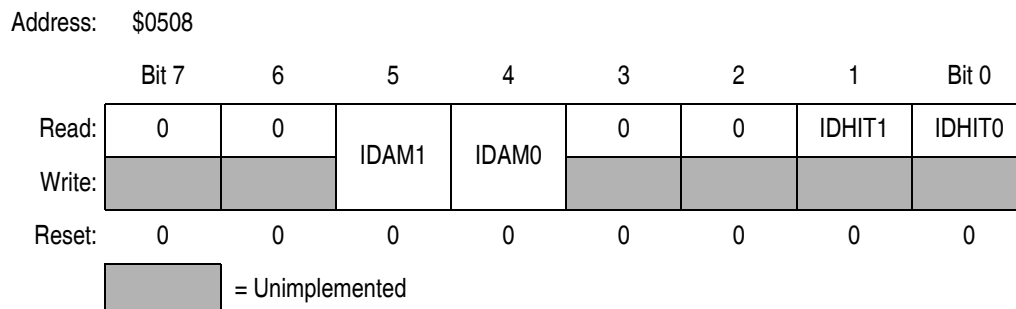
0 = No abort request

#### TXEIE2–TXEIE0 — Transmitter Empty Interrupt Enable

1 = A transmitter empty (transmit buffer available for transmission) event will result in a transmitter empty interrupt.

0 = No interrupt will be generated from this event.

## 23.14.9 MSCAN08 Identifier Acceptance Control Register (CIDAC)



**Figure 23-23. Identifier Acceptance Control Register (CIDAC)**

### IDAM1–IDAM0— Identifier Acceptance Mode

The CPU sets these flags to define the identifier acceptance filter organization (see [23.6 Identifier Acceptance Filter](#)). [Table 23-7](#) summarizes the different settings. In “filter closed” mode no messages will be accepted so that the foreground buffer will never be reloaded.

**Table 23-8. Identifier Acceptance Mode Settings**

IDAM1	IDAM0	Identifier Acceptance Mode
0	0	Single 32-Bit Acceptance Filter
0	1	Two 16-Bit Acceptance Filter
1	0	Four 8-Bit Acceptance Filters
1	1	Filter Closed

IDHIT1–IDHIT0— Identifier Acceptance Hit Indicator

The MSCAN08 sets these flags to indicate an identifier acceptance hit (see **23.6 Identifier Acceptance Filter**). **Table 23-7** summarizes the different settings.

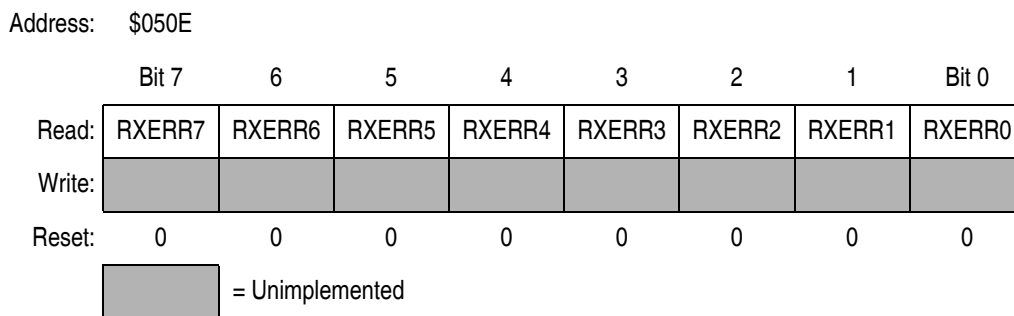
**Table 23-9. Identifier Acceptance Hit Indication**

IDHIT1	IDHIT0	Identifier Acceptance Hit
0	0	Filter 0 Hit
0	1	Filter 1 Hit
1	0	Filter 2 Hit
1	1	Filter 3 Hit

The IDHIT indicators are always related to the message in the foreground buffer. When a message gets copied from the background to the foreground buffer, the indicators are updated as well.

**NOTE:** *The CIDAC register can be written only if the SFTRES bit in the MSCAN08 module control register is set.*

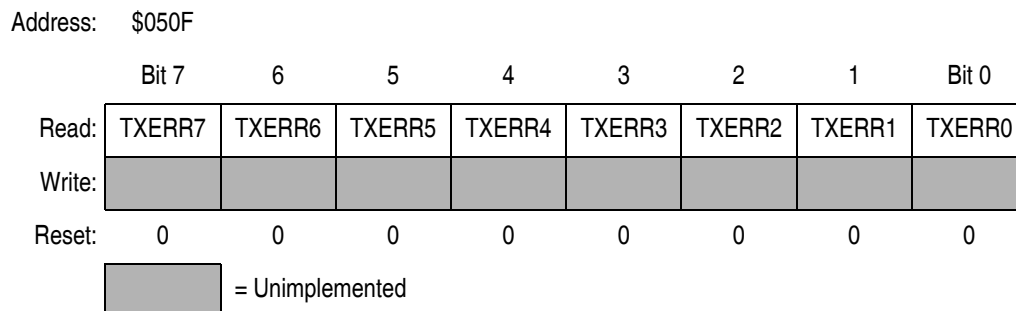
**23.14.10 MSCAN08 Receive Error Counter**



**Figure 23-24. Receiver Error Counter (CRXERR)**

This register reflects the status of the MSCAN08 receive error counter. The register is read only.

## 23.14.11 MSCAN08 Transmit Error Counter



**Figure 23-25. Transmit Error Counter (CTXERR)**

This register reflects the status of the MSCAN08 transmit error counter. The register is read only.

**NOTE:** *For both error counters, there is no hardware synchronization between the write accesses to those registers from the MSCAN08 side and the read accesses by the CPU. It is the user's responsibility to verify that a stable value has been read by executing a second validation read and comparing the two values.*

## 23.14.12 MSCAN08 Identifier Acceptance Registers

On reception each message is written into the background receive buffer. The CPU is only signalled to read the message, however, if it passes the criteria in the identifier acceptance and identifier mask registers (accepted); otherwise, the message will be overwritten by the next message (dropped).

The acceptance registers of the MSCAN08 are applied on the IDR0 to IDR3 registers of incoming messages in a bit by bit manner.

For extended identifiers, all four acceptance and mask registers are applied. For standard identifiers only the first two (IDAR0 and IDAR1) are applied. In the latter case, the mask register, CIDMR1, the three last bits (AC2–AC0) must be programmed to don't care.



Register Name and Address: CIDAR0 — \$0510

	Bit 7	6	5	4	3	2	1	Bit 0
Read:								
Write:	AC7	AC6	AC5	AC4	AC3	AC2	AC1	AC0
Reset:	Unaffected by Reset							

Register Name and Address: CIDAR1 — \$0511

	Bit 7	6	5	4	3	2	1	Bit 0
Read:								
Write:	AC7	AC6	AC5	AC4	AC3	AC2	AC1	AC0
Reset:	Unaffected by Reset							

Register Name and Address: CIDAR2 — \$0512

	Bit 7	6	5	4	3	2	1	Bit 0
Read:								
Write:	AC7	AC6	AC5	AC4	AC3	AC2	AC1	AC0
Reset:	Unaffected by Reset							

Register Name and Address: CIDAR3 — \$0513

	Bit 7	6	5	4	3	2	1	Bit 0
Read:								
Write:	AC7	AC6	AC5	AC4	AC3	AC2	AC1	AC0
Reset:	Unaffected by Reset							

**Figure 23-26. Identifier Acceptance Registers (CIDAR0–CIDAR3)**

#### AC7–AC0 — Acceptance Code Bits

AC7–AC0 comprise a user-defined sequence of bits with which the corresponding bits of the related identifier register (IDR<sub>n</sub>) of the receive message buffer are compared. The result of this comparison is then masked with the corresponding identifier mask register.

**NOTE:** *The CIDAR0–CIDAR3 registers can be written only if the SFTRES bit in the MSCAN08 module control register is set*

## 23.14.13 MSCAN08 Identifier Mask Registers (CIDMR0-3)

The identifier mask registers specify which of the corresponding bits in the identifier acceptance register are relevant for acceptance filtering.

Register Name and Address: CIDAR0 — \$0510

	Bit 7	6	5	4	3	2	1	Bit 0
Read:	AM7	AM6	AM5	AM4	AM3	AM2	AM1	AM0
Write:								
Reset:	Unaffected by Reset							

Register Name and Address: CIDAR1 — \$0511

	Bit 7	6	5	4	3	2	1	Bit 0
Read:	AM7	AM6	AM5	AM4	AM3	AM2	AM1	AM0
Write:								
Reset:	Unaffected by Reset							

Register Name and Address: CIDAR2 — \$0512

	Bit 7	6	5	4	3	2	1	Bit 0
Read:	AM7	AM6	AM5	AM4	AM3	AM2	AM1	AM0
Write:								
Reset:	Unaffected by Reset							

Register Name and Address: CIDAR3 — \$0513

	Bit 7	6	5	4	3	2	1	Bit 0
Read:	AM7	AM6	AM5	AM4	AM3	AM2	AM1	AM0
Write:								
Reset:	Unaffected by Reset							

**Figure 23-27. Identifier Mask Registers (CIDMR0–CIDMR3)**

### AM7–AM0 — Acceptance Mask Bits

If a particular bit in this register is cleared, this indicates that the corresponding bit in the identifier acceptance register must be the same as its identifier bit before a match will be detected. The message will be accepted if all such bits match. If a bit is set, it

indicates that the state of the corresponding bit in the identifier acceptance register will not affect whether or not the message is accepted.

1 = Ignore corresponding acceptance code register bit.

0 = Match corresponding acceptance code register and identifier bits.

**NOTE:** *The CIDMR0–CIDMR3 registers can be written only if the SFTRES bit in the MSCAN08 module control register is set.*





## Section 24. Keyboard Interrupt Module (KBD)

**NOTE:** This keyboard module is for the **MC68HC08AZ32 emulator** only.

### 24.1 Contents

24.2	Introduction . . . . .	444
24.3	Features . . . . .	444
24.4	Functional Description . . . . .	444
24.5	Keyboard Initialization . . . . .	447
24.6	Low-Power Modes . . . . .	448
24.6.1	Wait Mode . . . . .	448
24.6.2	Stop Mode . . . . .	448
24.7	Keyboard Module During Break Interrupts . . . . .	448
24.8	I/O Registers . . . . .	449
24.8.1	Keyboard Status and Control Register . . . . .	449
24.8.2	Keyboard Interrupt Enable Register . . . . .	450

## 24.2 Introduction

The keyboard interrupt module (KBD) provides five independently maskable external interrupt pins.

## 24.3 Features

KBD features include:

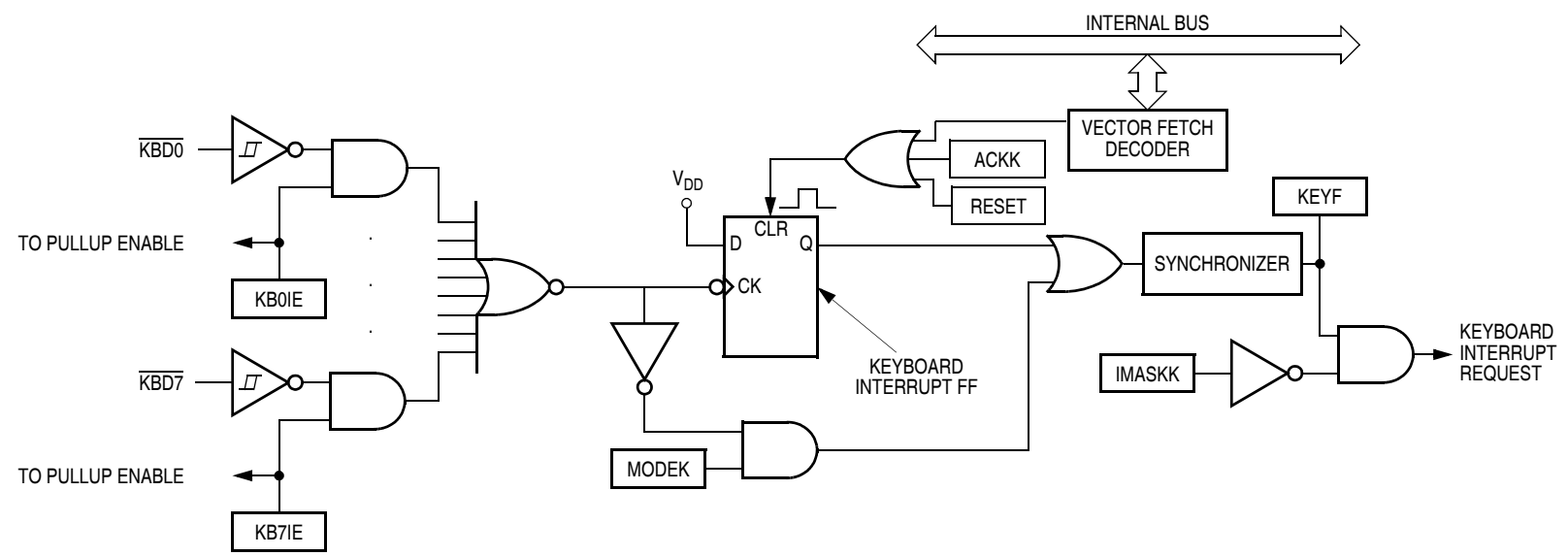
- Five Keyboard Interrupt Pins with Separate Keyboard Interrupt Enable Bits and One Keyboard Interrupt Mask
- Hysteresis Buffers
- Programmable Edge-Only or Edge- and Level- Interrupt Sensitivity
- Automatic Interrupt Acknowledge
- Exit from Low-Power Modes

## 24.4 Functional Description

Writing to the KBIE4–KBIE0 bits in the keyboard interrupt enable register independently enables or disables each port G or port H pin as a keyboard interrupt pin. Enabling a keyboard interrupt pin also enables its internal pullup device. A logic 0 applied to an enabled keyboard interrupt pin latches a keyboard interrupt request.

A keyboard interrupt is latched when one or more keyboard pins goes low after all were high. The MODEK bit in the keyboard status and control register controls the triggering mode of the keyboard interrupt.

- If the keyboard interrupt is edge-sensitive only, a falling edge on a keyboard pin does not latch an interrupt request if another keyboard pin is already low. To prevent losing an interrupt request on one pin because another pin is still low, software can disable the latter pin while it is low.
- If the keyboard interrupt is falling edge- and low level-sensitive, an interrupt request is present as long as any keyboard pin is low.



**Figure 24-1. Keyboard Module Block Diagram**

**Table 24-1. I/O Register Summary**

Register Name	Bit 7	6	5	4	3	2	1	Bit 0
Keyboard Status and Control Register (KBSCR)	Read:	0	0	0	0	KEYF	0	IMASKK
	Write:	[Unimplemented]						
	Reset:	0	0	0	0	0	0	0
Keyboard Interrupt Enable Register (KBIER)	Read:	0	0	0	KBIE4	KBIE3	KBIE2	KBIE1
	Write:	[Unimplemented]						
	Reset:	0	0	0	0	0	0	0

[Grey Box] = Unimplemented

**Table 24-2. I/O Register Address Summary**

Register	KBSCR	KBIER
Address	\$001B	\$0021

If the MODEK bit is set, the keyboard interrupt pins are both falling edge- and low level-sensitive, and both of the following actions must occur to clear a keyboard interrupt request:

- Vector fetch or software clear — A vector fetch generates an interrupt acknowledge signal to clear the interrupt request. Software may generate the interrupt acknowledge signal by writing a logic 1 to the ACKK bit in the keyboard status and control register (KBSCR). The ACKK bit is useful in applications that poll the keyboard interrupt pins and require software to clear the keyboard interrupt request. Writing to the ACKK bit prior to leaving an interrupt service routine also can prevent spurious interrupts due to noise. Setting ACKK does not affect subsequent transitions on the keyboard interrupt pins. A falling edge that occurs after writing to the ACKK bit latches another interrupt request. If the keyboard interrupt mask bit, IMASKK, is clear, the CPU loads the program counter with the vector address at locations \$FFDE and \$FFDF.
- Return of all enabled keyboard interrupt pins to logic 1. As long as any enabled keyboard interrupt pin is at logic 0, the keyboard interrupt remains set.

The vector fetch or software clear and the return of all enabled keyboard interrupt pins to logic 1 may occur in any order.

If the MODEK bit is clear, the keyboard interrupt pin is falling edge-sensitive only. With MODEK clear, a vector fetch or software clear immediately clears the keyboard interrupt request.

Reset clears the keyboard interrupt request and the MODEK bit, clearing the interrupt request even if a keyboard interrupt pin stays at logic 0.

The keyboard flag bit (KEYF) in the keyboard status and control register can be used to see if a pending interrupt exists. The KEYF bit is not affected by the keyboard interrupt mask bit (IMASKK) which makes it useful in applications where polling is preferred.

To determine the logic level on a keyboard interrupt pin, use the data direction register to configure the pin as an input and read the data register.



**NOTE:** *Setting a keyboard interrupt enable bit (KBIE<sub>x</sub>) forces the corresponding keyboard interrupt pin to be an input, overriding the data direction register. However, the data direction register bit must be a logic 0 for software to read the pin.*

## 24.5 Keyboard Initialization

When a keyboard interrupt pin is enabled, it takes time for the internal pullup to reach a logic 1. Therefore, a false interrupt can occur as soon as the pin is enabled.

To prevent a false interrupt on keyboard initialization:

1. Mask keyboard interrupts by setting the IMASKK bit in the keyboard status and control register
2. Enable the KBI pins by setting the appropriate KBIE<sub>x</sub> bits in the keyboard interrupt enable register
3. Write to the ACKK bit in the keyboard status and control register to clear any false interrupts
4. Clear the IMASKK bit.

An interrupt signal on an edge-triggered pin can be acknowledged immediately after enabling the pin. An interrupt signal on an edge- and level-triggered interrupt pin must be acknowledged after a delay that depends on the external load.

Another way to avoid a false interrupt:

1. Configure the keyboard pins as outputs by setting the appropriate DDRG bits in data direction register G.
2. Configure the keyboard pins as outputs by setting the appropriate DDRH bits in data direction register H.
3. Write logic 1s to the appropriate port G and port H data register bits.
4. Enable the KBI pins by setting the appropriate KBIE<sub>x</sub> bits in the keyboard interrupt enable register.

## 24.6 Low-Power Modes

The WAIT and STOP instructions put the MCU in low-power standby modes.

### 24.6.1 Wait Mode

The keyboard module remains active in wait mode. Clearing the IMASKK bit in the keyboard status and control register enables keyboard interrupt requests to bring the MCU out of wait mode.

### 24.6.2 Stop Mode

The keyboard module remains active in stop mode. Clearing the IMASKK bit in the keyboard status and control register enables keyboard interrupt requests to bring the MCU out of stop mode.

## 24.7 Keyboard Module During Break Interrupts

The BCFE bit in the break flag control register (BFCR) enables software to clear status bits during the break state. (See [Section 11. Break Module \(BRK\)](#).)

To allow software to clear the KEYF bit during a break interrupt, write a logic 1 to the BCFE bit. If KEYF is cleared during the break state, it remains cleared when the MCU exits the break state.

To protect the KEYF bit during the break state, write a logic 0 to the BCFE bit. With BCFE at logic 0, writing to the keyboard acknowledge bit (ACKK) in the keyboard status and control register during the break state has no effect. (See [24.8.1 Keyboard Status and Control Register](#).)

## 24.8 I/O Registers

The following registers control and monitor operation of the keyboard module:

- Keyboard status and control register (KBSCR)
- Keyboard interrupt enable register (KBIER)


### 24.8.1 Keyboard Status and Control Register

The keyboard status and control register:

- Flags keyboard interrupt requests
- Acknowledges keyboard interrupt requests
- Masks keyboard interrupt requests
- Controls keyboard interrupt triggering sensitivity

Address: \$001B

	Bit 7	6	5	4	3	2	1	Bit 0
Read:	0	0	0	0	KEYF	0	IMASKK	MODEK
Write:						ACKK		
Reset:	0	0	0	0	0	0	0	0

 = Unimplemented

**Figure 24-2. Keyboard Status and Control Register (KBSCR)**

Bits 7–4 — Not used

These read-only bits always read as logic 0s.

KEYF — Keyboard Flag Bit

This read-only bit is set when a keyboard interrupt is pending. Reset clears the KEYF bit.

1 = Keyboard interrupt pending

0 = No keyboard interrupt pending

### ACKK — Keyboard Acknowledge Bit

Writing a logic 1 to this write-only bit clears the keyboard interrupt request. ACKK always reads as logic 0. Reset clears ACKK.

### IMASKK — Keyboard Interrupt Mask Bit

Writing a logic 1 to this read/write bit prevents the output of the keyboard interrupt mask from generating interrupt requests. Reset clears the IMASKK bit.

- 1 = Keyboard interrupt requests masked
- 0 = Keyboard interrupt requests not masked

### MODEK — Keyboard Triggering Sensitivity Bit

This read/write bit controls the triggering sensitivity of the keyboard interrupt pins. Reset clears MODEK.

- 1 = Keyboard interrupt requests on falling edges and low levels
- 0 = Keyboard interrupt requests on falling edges only

## 24.8.2 Keyboard Interrupt Enable Register

The keyboard interrupt enable register enables or disables each port G and each port H pin to operate as a keyboard interrupt pin.

Address: \$0021

	Bit 7	6	5	4	3	2	1	Bit 0
Read:	0	0	0	KBIE4	KBIE3	KBIE2	KBIE1	KBIE0
Write:								
Reset:	0	0	0	0	0	0	0	0

= Unimplemented

**Figure 24-3. Keyboard Interrupt Enable Register (KBIER)**

### KBIE4–KBIE0 — Keyboard Interrupt Enable Bits

Each of these read/write bits enables the corresponding keyboard interrupt pin to latch interrupt requests. Reset clears the keyboard interrupt enable register.

- 1 = PDx pin enabled as keyboard interrupt pin
- 0 = PDx pin not enabled as keyboard interrupt pin

## Section 25. Timer Interface (TIMA-6)

**NOTE:** This timer is for the **J1850 (52-pin PLCC)** protocol only.

### 25.1 Contents

25.2	Introduction .....	452
25.3	Features .....	452
25.4	Functional Description .....	456
25.4.1	TIMA Counter Prescaler .....	456
25.4.2	Input Capture .....	456
25.4.3	Output Compare .....	458
25.4.3.1	Unbuffered Output Compare .....	458
25.4.3.2	Buffered Output Compare .....	459
25.4.4	Pulse Width Modulation (PWM) .....	460
25.4.4.1	Unbuffered PWM Signal Generation .....	462
25.4.4.2	Buffered PWM Signal Generation .....	463
25.4.4.3	PWM Initialization .....	464
25.5	Interrupts .....	466
25.6	Low-Power Modes .....	466
25.6.1	Wait Mode .....	466
25.6.2	Stop Mode .....	466
25.7	TIMA During Break Interrupts .....	467
25.8	I/O Signals .....	467
25.8.1	TIMA Clock Pin (PTD6/ATD14/TCLK) .....	467
25.8.2	TIMA Channel I/O Pins (PTF3/TACH5–PTF0/TACH2 and PTE3/TACH1–PTE2/TACH0) .....	468

25.9	I/O Registers . . . . .	468
25.9.1	TIMA Status and Control Register . . . . .	469
25.9.2	TIMA Counter Registers . . . . .	471
25.9.3	TIMA Counter Modulo Registers . . . . .	472
25.9.4	TIMA Channel Status and Control Registers . . . . .	473
25.9.5	TIMA Channel Registers . . . . .	478

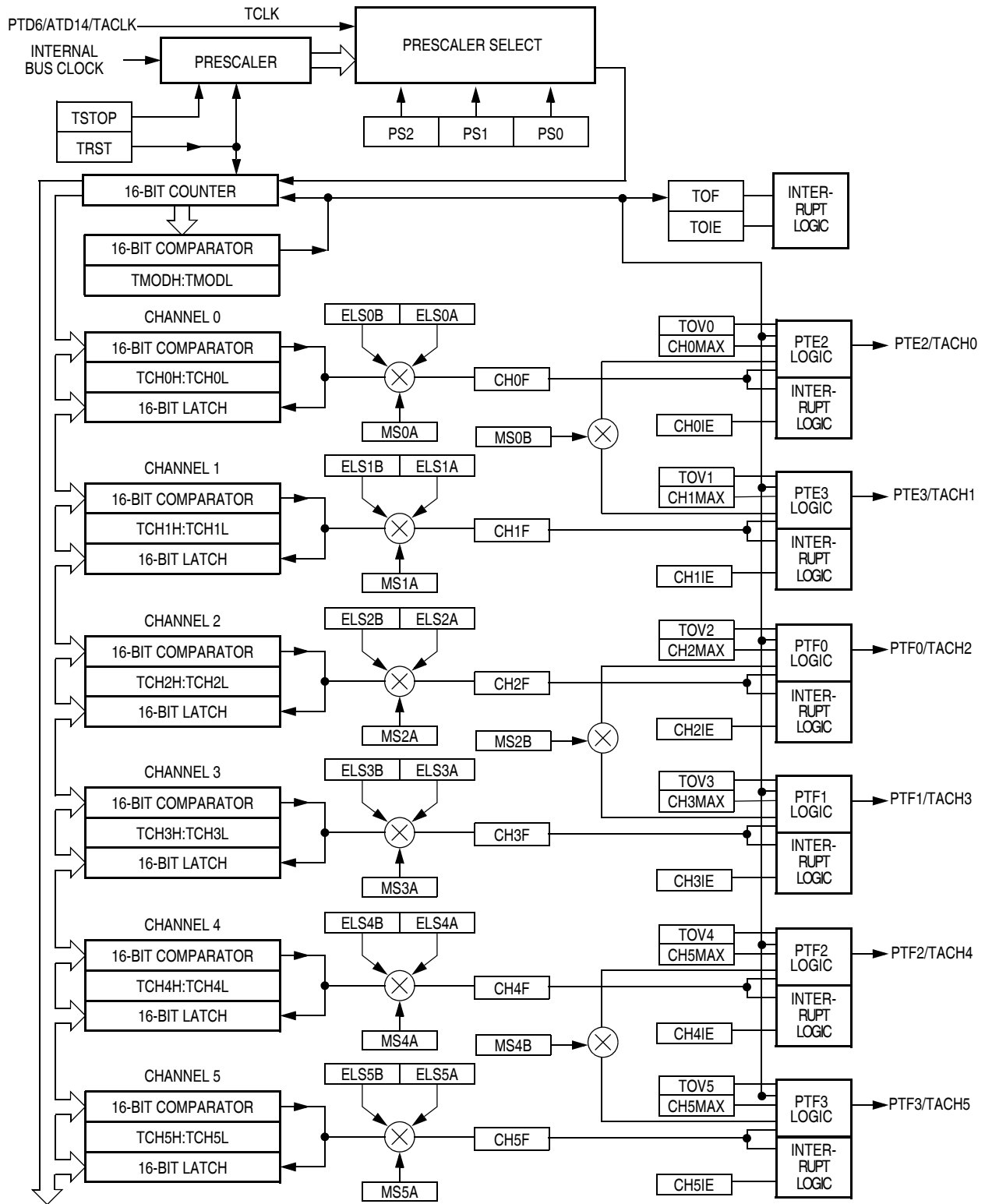
## 25.2 Introduction

This section describes the timer interface module (TIMA). The TIMA is a 6-channel timer that provides a timing reference with input capture, output compare, and pulse-width-modulation functions. **Figure 25-1** is a block diagram of the TIMA.

## 25.3 Features

Features of the TIMA include:

- Six Input Capture/Output Compare Channels
  - Rising-Edge, Falling-Edge, or Any-Edge Input Capture Trigger
  - Set, Clear, or Toggle Output Compare Action
- Buffered and Unbuffered Pulse Width Modulation (PWM) Signal Generation
- Programmable TIMA Clock Input
  - 7-Frequency Internal Bus Clock Prescaler Selection
  - External TIMA Clock Input (4-MHz Maximum Frequency)
- Free-Running or Modulo Up-Count Operation
- Toggle Any Channel Pin on Overflow
- TIMA Counter Stop and Reset Bits



**Figure 25-1. TIMA Block Diagram**

**Table 25-1. TIMA I/O Register Summary**

Addr.	Register Name	Bit 7	6	5	4	3	2	1	Bit 0	
\$0020	Timer A Status and Control Register (TASC)	Read:	TOF	TOIE	TSTOP	0	0	PS2	PS1	PS0
		Write:	0			TRST	R			
		Reset:	0	0	1	0	0	0	0	0
\$0021	Keyboard Interrupt Control Register (KBIER)	Read:	0	0	0	KBIE4	KBIE3	KBIE2	KBIE1	KBIE0
		Write:								
		Reset:	0	0	0	0	0	0	0	0
\$0022	Timer A Counter Register High (TACNTH)	Read:	Bit 15	14	13	12	11	10	9	Bit 8
		Write:	R	R	R	R	R	R	R	R
		Reset:	0	0	0	0	0	0	0	0
\$0023	Timer A Counter Register Low (TACNTL)	Read:	Bit 7	6	5	4	3	2	1	Bit 0
		Write:	R	R	R	R	R	R	R	R
		Reset:	0	0	0	0	0	0	0	0
\$0024	Timer A Modulo Register High (TAMODH)	Read:	Bit 15	14	13	12	11	10	9	Bit 8
		Write:								
		Reset:	1	1	1	1	1	1	1	1
\$0025	Timer A Modulo Register Low (TAMODL)	Read:	Bit 7	6	5	4	3	2	1	Bit 0
		Write:								
		Reset:	1	1	1	1	1	1	1	1
\$0026	Timer A Channel 0 Status and Control Register (TASC0)	Read:	CH0F	CH0IE	MS0B	MS0A	ELS0B	ELS0A	TOV0	CH0MAX
		Write:	0							
		Reset:	0	0	0	0	0	0	0	0
\$0027	Timer A Channel 0 Register High (TACH0H)	Read:	Bit 15	14	13	12	11	10	9	Bit 8
		Write:								
		Reset:	Indeterminate after Reset							
\$0028	Timer A Channel 0 Register Low (TACH0L)	Read:	Bit 7	6	5	4	3	2	1	Bit 0
		Write:								
		Reset:	Indeterminate after Reset							
\$0029	Timer A Channel 1 Status and Control Register (TASC1)	Read:	CH1F	CH1IE	0	MS1A	ELS1B	ELS1A	TOV1	CH1MAX
		Write:	0		R					
		Reset:	0	0	0	0	0	0	0	0

*Italic Type* = MC68HC08AS20 Specific

**Boldface Type** = MC68HC08AZ32 Specific

= Unimplemented    R = Reserved



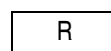
**Table 25-1. TIMA I/O Register Summary (Continued)**

Addr.	Register Name	Bit 7	6	5	4	3	2	1	Bit 0	
\$002A	Timer A Channel 1 Register High (TACH1H)	Read:	Bit 15	14	13	12	11	10	9	Bit 8
		Write:								
		Reset:	Indeterminate after Reset							
\$002B	Timer A Channel 1 Register Low (TACH1L)	Read:	Bit 7	6	5	4	3	2	1	Bit 0
		Write:								
		Reset:	Indeterminate after Reset							
\$002C	Timer A Channel 2 Status and Control Register (TASC2)	Read:	CH2F	CH2IE	MS2B	MS2A	ELS2B	ELS2A	TOV2	CH2MAX
		Write:	0							
		Reset:	0	0	0	0	0	0	0	0
\$002D	Timer A Channel 2 Register High (TACH2H)	Read:	Bit 15	14	13	12	11	10	9	Bit 8
		Write:								
		Reset:	Indeterminate after Reset							
\$002E	Timer A Channel 2 Register Low (TACH2L)	Read:	Bit 7	6	5	4	3	2	1	Bit 0
		Write:								
		Reset:	Indeterminate after Reset							
\$002F	Timer A Channel 3 Status and Control Register (TASC3)	Read:	CH3F	CH3IE	0	MS3A	ELS3B	ELS3A	TOV3	CH3MAX
		Write:	0		R					
		Reset:	0	0	0	0	0	0	0	0
\$0030	Timer A Channel 3 Register High (TACH3H)	Read:	Bit 15	14	13	12	11	10	9	Bit 8
		Write:								
		Reset:	Indeterminate after Reset							
\$0031	Timer A Channel 3 Register Low (TACH3L)	Read:	Bit 7	6	5	4	3	2	1	Bit 0
		Write:								
		Reset:	Indeterminate after Reset							
\$0032	Timer A Channel 4 Status and Control Register (TASC4)	Read:	CH4F	CH4IE	MS4B	MS4A	ELS4B	ELS4A	TOV4	CH4MAX
		Write:	0							
		Reset:	0	0	0	0	0	0	0	0
\$0033	Timer A Channel 4 Register High (TACH4H)	Read:	Bit 15	14	13	12	11	10	9	Bit 8
		Write:								
		Reset:	Indeterminate after Reset							
\$0034	Timer A Channel 4 Register Low (TACH4L)	Read:	Bit 7	6	5	4	3	2	1	Bit 0
		Write:								
		Reset:	Indeterminate after Reset							

*Italic Type* = MC68HC08AS20 Specific

**Boldface Type** = MC68HC08AZ32 Specific


= Unimplemented



= Reserved

**Table 25-1. TIMA I/O Register Summary (Continued)**

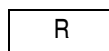
Addr.	Register Name	Bit 7	6	5	4	3	2	1	Bit 0		
\$0035	<i>Timer A Channel 5 Status and Control Register (TASC5)</i>	Read:	CH5F	CH5IE	0	MS5A	ELS5B	ELS5A	TOV5	CH5MAX	
		Write:	0		R						
		Reset:	0	0	0	0	0	0	0	0	
\$0036	<i>Timer A Channel 5 Register High (TACH5H)</i>	Read:	Bit 15	14	13	12	11	10	9	Bit 8	
		Write:									
		Reset:	Indeterminate after Reset								
\$0037	<i>Timer A Channel 5 Register Low (TACH5L)</i>	Read:	Bit 7	6	5	4	3	2	1	Bit 0	
		Write:									
		Reset:	Indeterminate after Reset								

*Italic Type* = MC68HC08AS20 Specific

**Boldface Type** = MC68HC08AZ32 Specific



= Unimplemented



= Reserved

## 25.4 Functional Description

**Figure 25-1** shows the TIMA structure. The central component of the TIMA is the 16-bit TIMA counter that can operate as a free-running counter or a modulo up-counter. The TIMA counter provides the timing reference for the input capture and output compare functions. The TIMA counter modulo registers, TAMODH–TAMODL, control the modulo value of the TIMA counter. Software can read the TIMA counter value at any time without affecting the counting sequence.

The six TIMA channels are programmable independently as input capture or output compare channels.

### 25.4.1 TIMA Counter Prescaler

The TIMA clock source can be one of the seven prescaler outputs or the TIMA clock pin, PTD6/ATD14/TACLK. The prescaler generates seven clock rates from the internal bus clock. The prescaler select bits, PS[2:0], in the TIMA status and control register select the TIMA clock source.

### 25.4.2 Input Capture

An input capture function has three basic parts: edge select logic, an input capture latch, and a 16-bit counter. Two 8-bit registers, which make

up the 16-bit input capture register, are used to latch the value of the free-running counter after the corresponding input capture edge detector senses a defined transition. The polarity of the active edge is programmable. The level transition which triggers the counter transfer is defined by the corresponding input edge bits (ELSxB and ELSxA in TASC0 through TASC5 control registers with x referring to the active channel number). When an active edge occurs on the pin of an input capture channel, the TIMA latches the contents of the TIMA counter into the TIMA channel registers, TACHxH–TACHxL. Input captures can generate TIMA CPU interrupt requests. Software can determine that an input capture event has occurred by enabling input capture interrupts or by polling the status flag bit.

The result obtained by an input capture will be two more than the value of the free-running counter on the rising edge of the internal bus clock preceding the external transition. This delay is required for internal synchronization.

The free-running counter contents are transferred to the TIMA channel status and control register (TACHxH–TACHxL, see [25.9.5 TIMA Channel Registers](#)) on each proper signal transition regardless of whether the TIMA channel flag (CH0F–CH5F in TASC0–TASC5 registers) is set or clear. When the status flag is set, a CPU interrupt is generated if enabled. The value of the count latched or “captured” is the time of the event. Because this value is stored in the input capture register 2 bus cycles after the actual event occurs, user software can respond to this event at a later time and determine the actual time of the event. However, this must be done prior to another input capture on the same pin; otherwise, the previous time value will be lost.

By recording the times for successive edges on an incoming signal, software can determine the period and/or pulse width of the signal. To measure a period, two successive edges of the same polarity are captured. To measure a pulse width, two alternate polarity edges are captured. Software should track the overflows at the 16-bit module counter to extend its range.

Another use for the input capture function is to establish a time reference. In this case, an input capture function is used in conjunction with an output compare function. For example, to activate an output

signal a specified number of clock cycles after detecting an input event (edge), use the input capture function to record the time at which the edge occurred. A number corresponding to the desired delay is added to this captured value and stored to an output compare register (see [25.9.5 TIMA Channel Registers](#)). Because both input captures and output compares are referenced to the same 16-bit modulo counter, the delay can be controlled to the resolution of the counter independent of software latencies.

Reset does not affect the contents of the input capture channel register (TACHxH–TACHxL).

### 25.4.3 Output Compare

With the output compare function, the TIMA can generate a periodic pulse with a programmable polarity, duration, and frequency. When the counter reaches the value in the registers of an output compare channel, the TIMA can set, clear, or toggle the channel pin. Output compares can generate TIMA CPU interrupt requests.

#### 25.4.3.1 Unbuffered Output Compare

Any output compare channel can generate unbuffered output compare pulses as described in [25.4.3 Output Compare](#). The pulses are unbuffered because changing the output compare value requires writing the new value over the old value currently in the TIMA channel registers.

An unsynchronized write to the TIMA channel registers to change an output compare value could cause incorrect operation for up to two counter overflow periods. For example, writing a new value before the counter reaches the old value but after the counter reaches the new value prevents any compare during that counter overflow period. Also, using a TIMA overflow interrupt routine to write a new, smaller output compare value may cause the compare to be missed. The TIMA may pass the new value before it is written.

Use the following methods to synchronize unbuffered changes in the output compare value on channel x:

- When changing to a smaller value, enable channel x output compare interrupts and write the new value in the output compare interrupt routine. The output compare interrupt occurs at the end of the current output compare pulse. The interrupt routine has until the end of the counter overflow period to write the new value.
- When changing to a larger output compare value, enable channel x TIMA overflow interrupts and write the new value in the TIMA overflow interrupt routine. The TIMA overflow interrupt occurs at the end of the current counter overflow period. Writing a larger value in an output compare interrupt routine (at the end of the current pulse) could cause two output compares to occur in the same counter overflow period.

### 25.4.3.2 Buffered Output Compare

Channels 0 and 1 can be linked to form a buffered output compare channel whose output appears on the PTE2/TACH0 pin. The TIMA channel registers of the linked pair alternately control the output.

Setting the MS0B bit in TIMA channel 0 status and control register (TASC0) links channel 0 and channel 1. The output compare value in the TIMA channel 0 registers initially controls the output on the PTE2/TACH0 pin. Writing to the TIMA channel 1 registers enables the TIMA channel 1 registers to synchronously control the output after the TIMA overflows. At each subsequent overflow, the TIMA channel registers (0 or 1) that control the output are the ones written to last. TASC0 controls and monitors the buffered output compare function, and TIMA channel 1 status and control register (TASC1) is unused. While the MS0B bit is set, the channel 1 pin, PTE3/TACH1, is available as a general-purpose I/O pin.

Channels 2 and 3 can be linked to form a buffered output compare channel whose output appears on the PTF0/TACH2 pin. The TIMA channel registers of the linked pair alternately control the output.

Setting the MS2B bit in TIMA channel 2 status and control register (TASC2) links channel 2 and channel 3. The output compare value in the TIMA channel 2 registers initially controls the output on the PTF0/TACH2 pin. Writing to the TIMA channel 3 registers enables the

TIMA channel 3 registers to synchronously control the output after the TIMA overflows. At each subsequent overflow, the TIMA channel registers (2 or 3) that control the output are the ones written to last. TASC2 controls and monitors the buffered output compare function, and TIMA channel 3 status and control register (TASC3) is unused. While the MS2B bit is set, the channel 3 pin, PTF1/TACH3, is available as a general-purpose I/O pin.

Channels 4 and 5 can be linked to form a buffered output compare channel whose output appears on the PTF2/TACH4 pin. The TIMA channel registers of the linked pair alternately control the output.

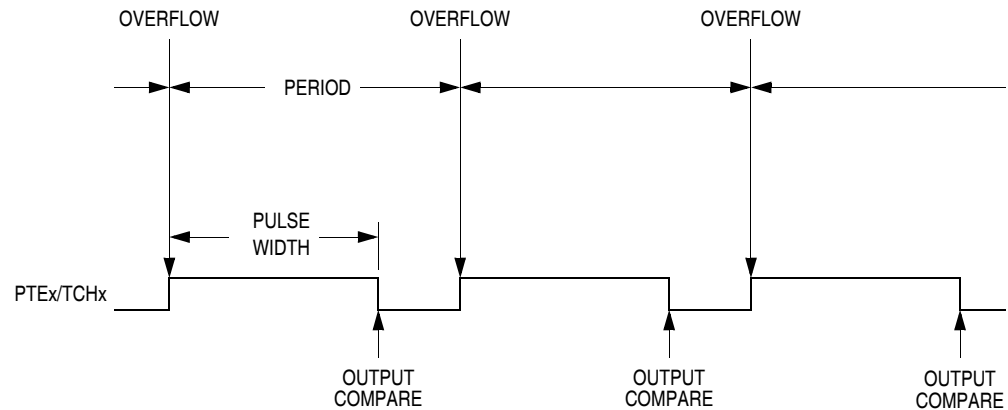
Setting the MS4B bit in TIMA channel 4 status and control register (TSC4) links channel 4 and channel 5. The output compare value in the TIMA channel 4 registers initially controls the output on the PTF2/TACH4 pin. Writing to the TIMA channel 5 registers enables the TIMA channel 5 registers to synchronously control the output after the TIMA overflows. At each subsequent overflow, the TIMA channel registers (4 or 5) that control the output are the ones written to last. TASC4 controls and monitors the buffered output compare function, and TIMA channel 5 status and control register (TASC5) is unused. While the MS4B bit is set, the channel 5 pin, PTF3/TACH5, is available as a general-purpose I/O pin.

**NOTE:** *In buffered output compare operation, do not write new output compare values to the currently active channel registers. Writing to the active channel registers is the same as generating unbuffered output compares.*

#### 25.4.4 Pulse Width Modulation (PWM)

By using the toggle-on-overflow feature with an output compare channel, the TIMA can generate a PWM signal. The value in the TIMA counter modulo registers determines the period of the PWM signal. The channel pin toggles when the counter reaches the value in the TIMA counter modulo registers. The time between overflows is the period of the PWM signal.

As [Figure 25-2](#) shows, the output compare value in the TIMA channel registers determines the pulse width of the PWM signal. The time between overflow and output compare is the pulse width. Program the TIMA to clear the channel pin on output compare if the state of the PWM pulse is logic 1. Program the TIMA to set the pin if the state of the PWM pulse is logic 0.



**Figure 25-2. PWM Period and Pulse Width**

The value in the TIMA counter modulo registers and the selected prescaler output determines the frequency of the PWM output. The frequency of an 8-bit PWM signal is variable in 256 increments. Writing \$00FF (255) to the TIMA counter modulo registers produces a PWM period of 256 times the internal bus clock period if the prescaler select value is \$000 (see [25.9.1 TIMA Status and Control Register](#)).

The value in the TIMA channel registers determines the pulse width of the PWM output. The pulse width of an 8-bit PWM signal is variable in 256 increments. Writing \$0080 (128) to the TIMA channel registers produces a duty cycle of 128/256 or 50%.

#### 25.4.4.1 Unbuffered PWM Signal Generation

Any output compare channel can generate unbuffered PWM pulses as described in [25.4.4 Pulse Width Modulation \(PWM\)](#). The pulses are unbuffered because changing the pulse width requires writing the new pulse width value over the value currently in the TIMA channel registers.

An unsynchronized write to the TIMA channel registers to change a pulse width value could cause incorrect operation for up to two PWM periods. For example, writing a new value before the counter reaches the old value but after the counter reaches the new value prevents any compare during that PWM period. Also, using a TIMA overflow interrupt routine to write a new, smaller pulse width value may cause the compare to be missed. The TIMA may pass the new value before it is written to the TIMA channel registers.

Use the following methods to synchronize unbuffered changes in the PWM pulse width on channel x:

- When changing to a shorter pulse width, enable channel x output compare interrupts and write the new value in the output compare interrupt routine. The output compare interrupt occurs at the end of the current pulse. The interrupt routine has until the end of the PWM period to write the new value.
- When changing to a longer pulse width, enable channel x TIMA overflow interrupts and write the new value in the TIMA overflow interrupt routine. The TIMA overflow interrupt occurs at the end of the current PWM period. Writing a larger value in an output compare interrupt routine (at the end of the current pulse) could cause two output compares to occur in the same PWM period.

**NOTE:** *In PWM signal generation, do not program the PWM channel to toggle on output compare. Toggling on output compare prevents reliable 0% duty cycle generation and removes the ability of the channel to self-correct in the event of software error or noise. Toggling on output compare also can cause incorrect PWM signal generation when changing the PWM pulse width to a new, much larger value.*



#### 25.4.4.2 Buffered PWM Signal Generation

Channels 0 and 1 can be linked to form a buffered PWM channel whose output appears on the PTE2/TACH0 pin. The TIMA channel registers of the linked pair alternately control the pulse width of the output.

Setting the MS0B bit in TIMA channel 0 status and control register (TASC0) links channel 0 and channel 1. The TIMA channel 0 registers initially control the pulse width on the PTE2/TACH0 pin. Writing to the TIMA channel 1 registers enables the TIMA channel 1 registers to synchronously control the pulse width at the beginning of the next PWM period. At each subsequent overflow, the TIMA channel registers (0 or 1) that control the pulse width are the ones written to last. TASC0 controls and monitors the buffered PWM function, and TIMA channel 1 status and control register (TASC1) is unused. While the MS0B bit is set, the channel 1 pin, PTE3/TACH1, is available as a general-purpose I/O pin.

Channels 2 and 3 can be linked to form a buffered PWM channel whose output appears on the PTF0/TACH2 pin. The TIMA channel registers of the linked pair alternately control the pulse width of the output.

Setting the MS2B bit in TIMA channel 2 status and control register (TASC2) links channel 2 and channel 3. The TIMA channel 2 registers initially control the pulse width on the PTF0/TACH2 pin. Writing to the TIMA channel 3 registers enables the TIMA channel 3 registers to synchronously control the pulse width at the beginning of the next PWM period. At each subsequent overflow, the TIMA channel registers (2 or 3) that control the pulse width are the ones written to last. TASC2 controls and monitors the buffered PWM function, and TIMA channel 3 status and control register (TASC3) is unused. While the MS2B bit is set, the channel 3 pin, PTF1/TACH3, is available as a general-purpose I/O pin.

Channels 4 and 5 can be linked to form a buffered PWM channel whose output appears on the PTF2/TACH4 pin. The TIMA channel registers of the linked pair alternately control the pulse width of the output.

Setting the MS4B bit in TIMA channel 4 status and control register (TASC4) links channel 4 and channel 5. The TIMA channel 4 registers

initially control the pulse width on the PTF2/TACH4 pin. Writing to the TIMA channel 5 registers enables the TIMA channel 5 registers to synchronously control the pulse width at the beginning of the next PWM period. At each subsequent overflow, the TIMA channel registers (4 or 5) that control the pulse width are the ones written to last. TASC4 controls and monitors the buffered PWM function, and TIMA channel 5 status and control register (TASC5) is unused. While the MS4B bit is set, the channel 5 pin, PTF3/TACH5, is available as a general-purpose I/O pin.

**NOTE:** *In buffered PWM signal generation, do not write new pulse width values to the currently active channel registers. Writing to the active channel registers is the same as generating unbuffered PWM signals.*

#### 25.4.4.3 PWM Initialization

To ensure correct operation when generating unbuffered or buffered PWM signals, use the following initialization procedure:

1. In the TIMA status and control register (TASC):
  - a. Stop the TIMA counter by setting the TIMA stop bit, TSTOP.
  - b. Reset the TIMA counter by setting the TIMA reset bit, TRST.
2. In the TIMA counter modulo registers (TAMODH–TAMODL), write the value for the required PWM period.
3. In the TIMA channel x registers (TACHxH–TACHxL), write the value for the required pulse width.
4. In TIMA channel x status and control register (TSCx):
  - a. Write 0:1 (for unbuffered output compare or PWM signals) or 1:0 (for buffered output compare or PWM signals) to the mode select bits, MSxB–MSxA. (See [Table 25-3](#).)
  - b. Write 1 to the toggle-on-overflow bit, TOVx.
  - c. Write 1:0 (to clear output on compare) or 1:1 (to set output on compare) to the edge/level select bits, ELSxB–ELSxA. The output action on compare must force the output to the complement of the pulse width level. (See [Table 25-3](#).)

**NOTE:** *In PWM signal generation, do not program the PWM channel to toggle on output compare. Toggling on output compare prevents reliable 0% duty cycle generation and removes the ability of the channel to self-correct in the event of software error or noise. Toggling on output compare can also cause incorrect PWM signal generation when changing the PWM pulse width to a new, much larger value.*

5. In the TIMA status control register (TASC), clear the TIMA stop bit, TSTOP.

Setting MS0B links channels 0 and 1 and configures them for buffered PWM operation. The TIMA channel 0 registers (TACH0H–TACH0L) initially control the buffered PWM output. TIMA status control register 0 (TASC0) controls and monitors the PWM signal from the linked channels. MS0B takes priority over MS0A.

Setting MS2B links channels 2 and 3 and configures them for buffered PWM operation. The TIMA channel 2 registers (TACH2H–TACH2L) initially control the PWM output. TIMA status control register 2 (TASC2) controls and monitors the PWM signal from the linked channels. MS2B takes priority over MS2A.

Setting MS4B links channels 4 and 5 and configures them for buffered PWM operation. The TIMA channel 4 registers (TACH4H–TACH4L) initially control the PWM output. TIMA status control register 4 (TASC4) controls and monitors the PWM signal from the linked channels. MS4B takes priority over MS4A.

Clearing the toggle-on-overflow bit, TOVx, inhibits output toggles on TIMA overflows. Subsequent output compares try to force the output to a state it is already in and have no effect. The result is a 0% duty cycle output.

Setting the channel x maximum duty cycle bit (CHxMAX) and clearing the TOVx bit generates a 100% duty cycle output. (See [25.9.4 TIMA Channel Status and Control Registers](#).)

## 25.5 Interrupts

The following TIMA sources can generate interrupt requests:

- TIMA overflow flag (TOF) — The TOF bit is set when the TIMA counter value rolls over to \$0000 after matching the value in the TIMA counter modulo registers. The TIMA overflow interrupt enable bit, TOIE, enables TIMA overflow CPU interrupt requests. TOF and TOIE are in the TIMA status and control register.
- TIMA channel flags (CH5F–CH0F) — The CHxF bit is set when an input capture or output compare occurs on channel x. Channel x TIMA CPU interrupt requests are controlled by the channel x interrupt enable bit, CHxIE.

## 25.6 Low-Power Modes

The WAIT and STOP instructions put the MCU in low-power standby modes.

### 25.6.1 Wait Mode

The TIMA remains active after the execution of a WAIT instruction. In wait mode, the TIMA registers are not accessible by the CPU. Any enabled CPU interrupt request from the TIMA can bring the MCU out of wait mode.

If TIMA functions are not required during wait mode, reduce power consumption by stopping the TIMA before executing the WAIT instruction.

### 25.6.2 Stop Mode

The TIMA is inactive after the execution of a STOP instruction. The STOP instruction does not affect register conditions or the state of the TIMA counter. TIMA operation resumes when the MCU exits stop mode.

## 25.7 TIMA During Break Interrupts

A break interrupt stops the TIMA counter and inhibits input captures.

The system integration module (SIM) controls whether status bits in other modules can be cleared during the break state. The BCFE bit in the SIM break flag control register (SBFCR) enables software to clear status bits during the break state. (See [7.8.3 SIM Break Flag Control Register](#).)

To allow software to clear status bits during a break interrupt, write a logic 1 to the BCFE bit. If a status bit is cleared during the break state, it remains cleared when the MCU exits the break state.

To protect status bits during the break state, write a logic 0 to the BCFE bit. With BCFE at logic 0 (its default state), software can read and write I/O registers during the break state without affecting status bits. Some status bits have a 2-step read/write clearing procedure. If software does the first step on such a bit before the break, the bit cannot change during the break state as long as BCFE is at logic 0. After the break, doing the second step clears the status bit.

## 25.8 I/O Signals

Port D shares one of its pins with the TIMA. Port E shares two of its pins with the TIMA and port F shares four of its pins with the TIMA.

PTD6/ATD14/TACLK is an external clock input to the TIMA prescaler.

The six TIMA channel I/O pins are PTE2/TACH0, PTE3/TACH1, PTF0/TACH2, PTF1/TACH3, PTF2/TACH4, and PTF3/TACH5.

### 25.8.1 TIMA Clock Pin (PTD6/ATD14/TCLK)

PTD6/ATD14/TACLK is an external clock input that can be the clock source for the TIMA counter instead of the prescaled internal bus clock. Select the PTD6/ATD14/TACLK input by writing logic 1s to the three

prescaler select bits, PS[2:0]. (See [25.9.1 TIMA Status and Control Register](#).) The minimum TCLK pulse width,  $TCLK_{L\text{MIN}}$  or  $TCLK_{H\text{MIN}}$ , is:

$$\frac{1}{\text{bus frequency}} + t_{\text{SU}}$$

The maximum TCLK frequency is the least: 4 MHz or bus frequency  $\div 2$ .

PTD6/ATD14/TACLK is available as a general-purpose I/O pin or ADC channel when not used as the TIMA clock input. When the PTD6/ATD14/TACLK pin is the TIMA clock input, it is an input regardless of the state of the DDRD6 bit in data direction register D.

### 25.8.2 TIMA Channel I/O Pins (PTF3/TACH5–PTF0/TACH2 and PTE3/TACH1–PTE2/TACH0)

Each channel I/O pin is programmable independently as an input capture pin or an output compare pin. PTE2/TACH0, PTE6/TACH2, and PTF2/TACH4 can be configured as buffered output compare or buffered PWM pins.

## 25.9 I/O Registers

These I/O registers control and monitor TIMA operation:

- TIMA status and control register (TASC)
- TIMA control registers (TACNTH–TACNTL)
- TIMA counter modulo registers (TAMODH–TAMODL)
- TIMA channel status and control registers (TASC0, TASC1, TASC2, TASC3, TASC4, and TSAC5)
- TIMA channel registers (TACH0H–TACH0L, TACH1H–TACH1L, TACH2H–TACH2L, TACH3H–TACH3L, TACH4H–TACH4L, and TACH5H–TACH5L)

### 25.9.1 TIMA Status and Control Register

The TIMA status and control register:

- Enables TIMA overflow interrupts
- Flags TIMA overflows
- Stops the TIMA counter
- Resets the TIMA counter
- Prescales the TIMA counter clock

Address: \$0020

	Bit 7	6	5	4	3	2	1	Bit 0
Read:	TOF	TOIE	TSTOP	0	0	PS2	PS1	PS0
Write:	0			TRST	R			
Reset:	0	0	1	0	0	0	0	0

R = Reserved

**Figure 25-3. TIMA Status and Control Register (TASC)**

#### TOF — TIMA Overflow Flag Bit

This read/write flag is set when the TIMA counter resets to \$0000 after reaching the modulo value programmed in the TIMA counter modulo registers. Clear TOF by reading the TIMA status and control register when TOF is set and then writing a logic 0 to TOF. If another TIMA overflow occurs before the clearing sequence is complete, then writing logic 0 to TOF has no effect. Therefore, a TOF interrupt request cannot be lost due to inadvertent clearing of TOF. Reset clears the TOF bit. Writing a logic 1 to TOF has no effect.

1 = TIMA counter has reached modulo value.

0 = TIMA counter has not reached modulo value.

#### TOIE — TIMA Overflow Interrupt Enable Bit

This read/write bit enables TIMA overflow interrupts when the TOF bit becomes set. Reset clears the TOIE bit.

1 = TIMA overflow interrupts enabled

0 = TIMA overflow interrupts disabled

## TSTOP — TIMA Stop Bit

This read/write bit stops the TIMA counter. Counting resumes when TSTOP is cleared. Reset sets the TSTOP bit, stopping the TIMA counter until software clears the TSTOP bit.

1 = TIMA counter stopped

0 = TIMA counter active

**NOTE:** *Do not set the TSTOP bit before entering wait mode if the TIMA is required to exit wait mode. Also, when the TSTOP bit is set and input capture mode is enabled, input captures are inhibited until TSTOP is cleared.*

## TRST — TIMA Reset Bit

Setting this write-only bit resets the TIMA counter and the TIMA prescaler. Setting TRST has no effect on any other registers. Counting resumes from \$0000. TRST is cleared automatically after the TIMA counter is reset and always reads as logic 0. Reset clears the TRST bit.

1 = Prescaler and TIMA counter cleared

0 = No effect

**NOTE:** *Setting the TSTOP and TRST bits simultaneously stops the TIMA counter at a value of \$0000.*

## PS[2:0] — Prescaler Select Bits

These read/write bits select either the PTD6/ATD14/TACLK pin or one of the seven prescaler outputs as the input to the TIMA counter as [Table 25-2](#) shows. Reset clears the PS[2:0] bits.

**Table 25-2. Prescaler Selection**

PS[2:0]	TIMA Clock Source
000	Internal Bus Clock ÷ 1
001	Internal Bus Clock ÷ 2
010	Internal Bus Clock ÷ 4
011	Internal Bus Clock ÷ 8
100	Internal Bus Clock ÷ 16
101	Internal Bus Clock ÷ 32
110	Internal Bus Clock ÷ 64
111	PTD6/ATD14/TACLK



## 25.9.2 TIMA Counter Registers

The two read-only TIMA counter registers contain the high and low bytes of the value in the TIMA counter. Reading the high byte (TACNTH) latches the contents of the low byte (TACNTL) into a buffer. Subsequent reads of TACNTH do not affect the latched TACNTL value until TACNTL is read. Reset clears the TIMA counter registers. Setting the TIMA reset bit (TRST) also clears the TIMA counter registers.

**NOTE:** *If TACNTH is read during a break interrupt, be sure to unlatch TACNTL by reading TACNTL before exiting the break interrupt. Otherwise, TACNTL retains the value latched during the break.*

Register Name and Address: TCNTH — \$0022

	Bit 7	6	5	4	3	2	1	Bit 0
Read:	BIT 15	BIT 14	BIT 13	BIT 12	BIT 11	BIT 10	BIT 9	BIT 8
Write:	R	R	R	R	R	R	R	R
Reset:	0	0	0	0	0	0	0	0

Register Name and Address: TCNTL — \$0023

	Bit 7	6	5	4	3	2	1	Bit 0
Read:	BIT 7	BIT 6	BIT 5	BIT 4	BIT 3	BIT 2	BIT 1	BIT 0
Write:	R	R	R	R	R	R	R	R
Reset:	0	0	0	0	0	0	0	0

R
---

 = Reserved

**Figure 25-4. TIMA Counter Registers (TCNTH and TCNTL)**

## 25.9.3 TIMA Counter Modulo Registers

The read/write TIMA modulo registers contain the modulo value for the TIMA counter. When the TIMA counter reaches the modulo value, the overflow flag (TOF) becomes set, and the TIMA counter resumes counting from \$0000 at the next clock. Writing to the high byte (TAMODH) inhibits the TOF bit and overflow interrupts until the low byte (TAMODL) is written. Reset sets the TIMA counter modulo registers.

Register Name and Address: TAMODH — \$0024

	Bit 7	6	5	4	3	2	1	Bit 0
Read:	BIT 15	BIT 14	BIT 13	BIT 12	BIT 11	BIT 10	BIT 9	BIT 8
Write:								
Reset:	1	1	1	1	1	1	1	1

Register Name and Address: TAMODL — \$0025

	Bit 7	6	5	4	3	2	1	Bit 0
Read:	BIT 7	BIT 6	BIT 5	BIT 4	BIT 3	BIT 2	BIT 1	BIT 0
Write:								
Reset:	1	1	1	1	1	1	1	1

**Figure 25-5. TIMA Counter Modulo Registers (TAMODH and TAMODL)**

**NOTE:** *Reset the TIMA counter before writing to the TIMA counter modulo registers.*

### 25.9.4 TIMA Channel Status and Control Registers

Each of the TIMA channel status and control registers:

- Flags input captures and output compares
- Enables input capture and output compare interrupts
- Selects input capture, output compare, or PWM operation
- Selects high, low, or toggling output on output compare
- Selects rising edge, falling edge, or any edge as the active input capture trigger
- Selects output toggling on TIMA overflow
- Selects 100% PWM duty cycle
- Selects buffered or unbuffered output compare/PWM operation

Register Name and Address: TASC0 — \$0026

	Bit 7	6	5	4	3	2	1	Bit 0
Read:	CH0F	CH0IE	MS0B	MS0A	ELS0B	ELS0A	TOV0	CH0MAX
Write:	0							
Reset:	0	0	0	0	0	0	0	0

Register Name and Address: TASC1 — \$0029

	Bit 7	6	5	4	3	2	1	Bit 0
Read:	CH1F	CH1IE	0	MS1A	ELS1B	ELS1A	TOV1	CH1MAX
Write:	0		R					
Reset:	0	0	0	0	0	0	0	0

R = Reserved

**Figure 25-6. TIMA Channel Status and Control Registers (TACC0–TASC5)**

# Timer Interface (TIMA-6)

Register Name and Address: TASC2 — \$002C

	Bit 7	6	5	4	3	2	1	Bit 0
Read:	CH2F	CH2IE	MS2B	MS2A	ELS2B	ELS2A	TOV2	CH2MAX
Write:	0							
Reset:	0	0	0	0	0	0	0	0

Register Name and Address: TASC3 — \$002F

	Bit 7	6	5	4	3	2	1	Bit 0
Read:	CH3F	CH3IE	0	MS3A	ELS3B	ELS3A	TOV3	CH3MAX
Write:	0		R					
Reset:	0	0	0	0	0	0	0	0

Register Name and Address: TASC4 — \$0032

	Bit 7	6	5	4	3	2	1	Bit 0
Read:	CH4F	CH4IE	MS4B	MS4A	ELS4B	ELS4A	TOV4	CH4MAX
Write:	0							
Reset:	0	0	0	0	0	0	0	0

Register Name and Address: TASC5 — \$0035

	Bit 7	6	5	4	3	2	1	Bit 0
Read:	CH5F	CH5IE	0	MS5A	ELS5B	ELS5A	TOV5	CH5MAX
Write:	0		R					
Reset:	0	0	0	0	0	0	0	0

R
---

 = Reserved

**Figure 25-6. TIMA Channel Status and Control Registers (TACC0–TASC5) (Continued)**

### CHxF — Channel x Flag Bit

When channel x is an input capture channel, this read/write bit is set when an active edge occurs on the channel x pin. When channel x is an output compare channel, CHxF is set when the value in the TIMA counter registers matches the value in the TIMA channel x registers.

When CHxIE = 0, clear CHxF by reading TIMA channel x status and control register with CHxF set, and then writing a logic 0 to CHxF. If another interrupt request occurs before the clearing sequence is complete, then writing logic 0 to CHxF has no effect. Therefore, an interrupt request cannot be lost due to inadvertent clearing of CHxF.

Reset clears the CHxF bit. Writing a logic 1 to CHxF has no effect.

1 = Input capture or output compare on channel x

0 = No input capture or output compare on channel x

### CHxIE — Channel x Interrupt Enable Bit

This read/write bit enables TIMA CPU interrupts on channel x.

Reset clears the CHxIE bit.

1 = Channel x CPU interrupt requests enabled

0 = Channel x CPU interrupt requests disabled

### MSxB — Mode Select Bit B

This read/write bit selects buffered output compare/PWM operation. MSxB exists only in the TIMA channel 0, TIMA channel 2, and TIMA channel 4 status and control registers.

Setting MS0B disables the channel 1 status and control register and reverts TACH1 pin to general-purpose I/O.

Setting MS2B disables the channel 3 status and control register and reverts TACH3 pin to general-purpose I/O.

Setting MS4B disables the channel 5 status and control register and reverts TACH5 pin to general-purpose I/O.

Reset clears the MSxB bit.

1 = Buffered output compare/PWM operation enabled

0 = Buffered output compare/PWM operation disabled

**MSxA — Mode Select Bit A**

When ELSxB:A  $\neq$  00, this read/write bit selects either input capture operation or unbuffered output compare/PWM operation. (See [Table 25-3](#).)

1 = Unbuffered output compare/PWM operation

0 = Input capture operation

When ELSxB:A = 00, this read/write bit selects the initial output level of the TCHx pin once PWM, output compare mode, or input capture mode is enabled. (See [Table 25-3](#).) Reset clears the MSxA bit.

1 = Initial output level low

0 = Initial output level high

**NOTE:** *Before changing a channel function by writing to the MSxB or MSxA bit, set the TSTOP and TRST bits in the TIMA status and control register (TSC).*

**ELSxB and ELSxA — Edge/Level Select Bits**

When channel x is an input capture channel, these read/write bits control the active edge-sensing logic on channel x.

When channel x is an output compare channel, ELSxB and ELSxA control the channel x output behavior when an output compare occurs.

When ELSxB and ELSxA are both clear, channel x is not connected to port E or port F, and pin PTE<sub>x</sub>/TACH<sub>x</sub> or pin PTF<sub>x</sub>/TACH<sub>x</sub> is available as a general-purpose I/O pin. However, channel x is at a state determined by these bits and becomes transparent to the respective pin when PWM, input capture mode, or output compare operation mode is enabled. [Table 25-3](#) shows how ELSxB and ELSxA work. Reset clears the ELSxB and ELSxA bits.

**Table 25-3. Mode, Edge, and Level Selection**

MSxB:MSxA	ELSxB:ELSxA	Mode	Configuration
X0	00	Output Preset	Pin under Port Control; Initialize Timer Output Level High
X1	00		Pin under Port Control; Initialize Timer Output Level Low
00	01	Input Capture	Capture on Rising Edge Only
00	10		Capture on Falling Edge Only
00	11		Capture on Rising or Falling Edge
01	01	Output Compare or PWM	Toggle Output on Compare
01	10		Clear Output on Compare
01	11		Set Output on Compare
1X	01	Buffered Output Compare or Buffered PWM	Toggle Output on Compare
1X	10		Clear Output on Compare
1X	11		Set Output on Compare

**NOTE:** Before enabling a TIMA channel register for input capture operation, make sure that the PTE<sub>x</sub>/TACH<sub>x</sub> pin or PTF<sub>x</sub>/TACH<sub>x</sub> pin is stable for at least two bus clocks.

#### TOV<sub>x</sub> — Toggle-On-Overflow Bit

When channel x is an output compare channel, this read/write bit controls the behavior of the channel x output when the TIMA counter overflows. When channel x is an input capture channel, TOV<sub>x</sub> has no effect. Reset clears the TOV<sub>x</sub> bit.

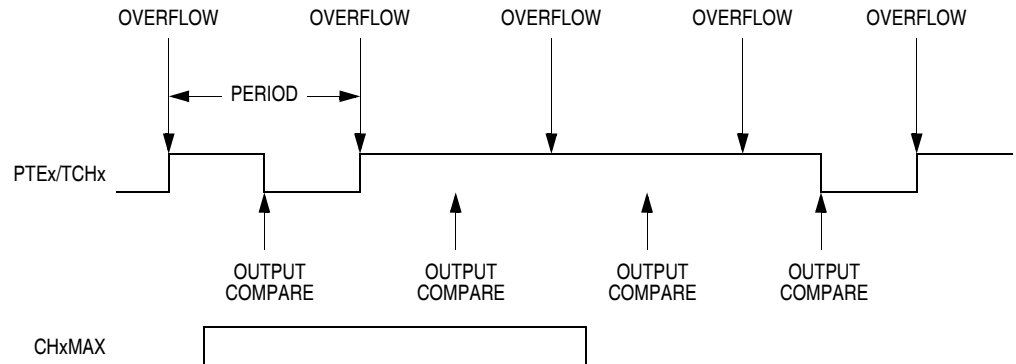
1 = Channel x pin toggles on TIMA counter overflow.

0 = Channel x pin does not toggle on TIMA counter overflow.

**NOTE:** When TOV<sub>x</sub> is set, a TIMA counter overflow takes precedence over a channel x output compare if both occur at the same time.

## CHxMAX — Channel x Maximum Duty Cycle Bit

When the TOVx bit is at logic 0, setting the CHxMAX bit forces the duty cycle of buffered and unbuffered PWM signals to 100%. As [Figure 25-7](#) shows, the CHxMAX bit takes effect in the cycle after it is set or cleared. The output stays at the 100% duty cycle level until the cycle after CHxMAX is cleared.



**Figure 25-7. CHxMAX Latency**

### 25.9.5 TIMA Channel Registers

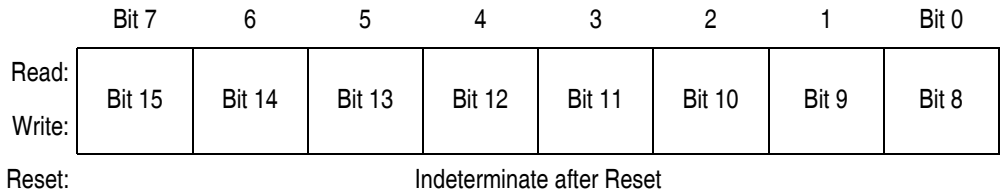
These read/write registers contain the captured TIMA counter value of the input capture function or the output compare value of the output compare function. The state of the TIMA channel registers after reset is unknown.

In input capture mode ( $MSxB-MSxA = 0:0$ ), reading the high byte of the TIMA channel x registers (TCHxH) inhibits input captures until the low byte (TCHxL) is read.

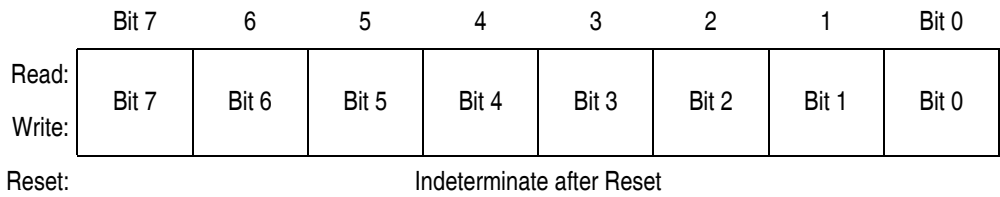
In output compare mode ( $MSxB-MSxA \neq 0:0$ ), writing to the high byte of the TIMA channel x registers (TCHxH) inhibits output compares until the low byte (TCHxL) is written.



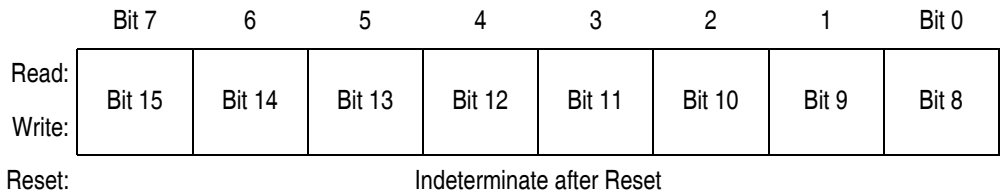
Register Name and Address: TACH0H — \$0027



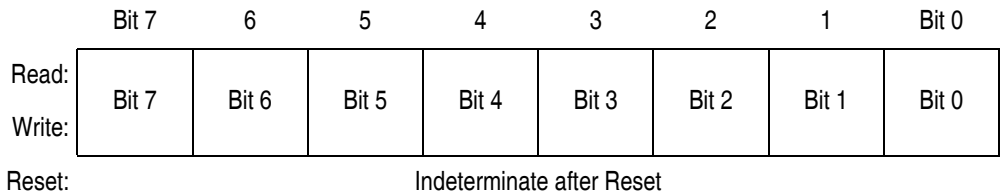
Register Name and Address: TACH0L — \$0028



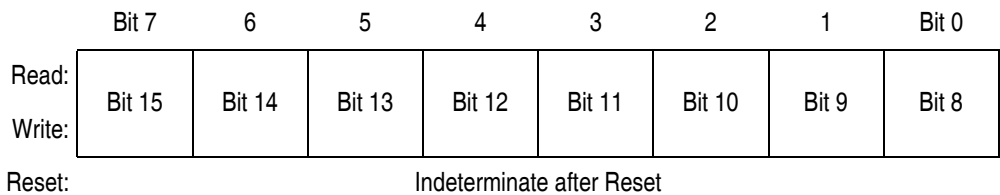
Register Name and Address: TACH1H — \$002A



Register Name and Address: TACH1L — \$002B



Register Name and Address: TACH2H — \$002D



**Figure 25-8. TIMA Channel Registers  
(TACH0H/L–TACH3H/L) (Sheet 1 of 3)**

Register Name and Address: TACH2L — \$002E

	Bit 7	6	5	4	3	2	1	Bit 0
Read:	Bit 7	Bit 6	Bit 5	Bit 4	Bit 3	Bit 2	Bit 1	Bit 0
Write:	Bit 7	Bit 6	Bit 5	Bit 4	Bit 3	Bit 2	Bit 1	Bit 0
Reset:	Indeterminate after Reset							

Register Name and Address: TACH3H — \$0030

	Bit 7	6	5	4	3	2	1	Bit 0
Read:	Bit 15	Bit 14	Bit 13	Bit 12	Bit 11	Bit 10	Bit 9	Bit 8
Write:	Bit 15	Bit 14	Bit 13	Bit 12	Bit 11	Bit 10	Bit 9	Bit 8
Reset:	Indeterminate after Reset							

Register Name and Address: TACH3L — \$0031

	Bit 7	6	5	4	3	2	1	Bit 0
Read:	Bit 7	Bit 6	Bit 5	Bit 4	Bit 3	Bit 2	Bit 1	Bit 0
Write:	Bit 7	Bit 6	Bit 5	Bit 4	Bit 3	Bit 2	Bit 1	Bit 0
Reset:	Indeterminate after Reset							

Register Name and Address: TACH4H — \$0033

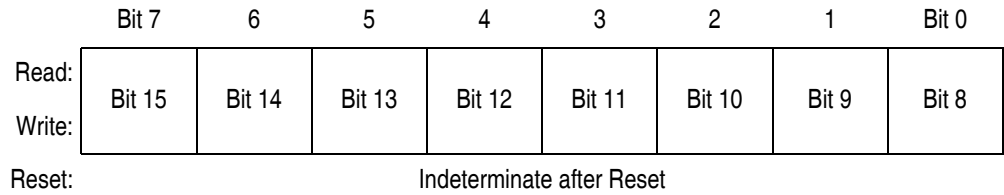
	Bit 7	6	5	4	3	2	1	Bit 0
Read:	Bit 15	Bit 14	Bit 13	Bit 12	Bit 11	Bit 10	Bit 9	Bit 8
Write:	Bit 15	Bit 14	Bit 13	Bit 12	Bit 11	Bit 10	Bit 9	Bit 8
Reset:	Indeterminate after Reset							

Register Name and Address: TACH4L — \$0034

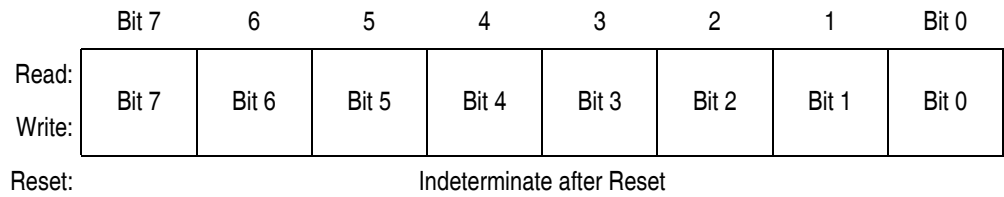
	Bit 7	6	5	4	3	2	1	Bit 0
Read:	Bit 7	Bit 6	Bit 5	Bit 4	Bit 3	Bit 2	Bit 1	Bit 0
Write:	Bit 7	Bit 6	Bit 5	Bit 4	Bit 3	Bit 2	Bit 1	Bit 0
Reset:	Indeterminate after Reset							

**Figure 25-8. TIMA Channel Registers (TACH0H/L–TACH3H/L) (Sheet 2 of 3)**

Register Name and Address: TACH5H — \$0036



Register Name and Address: TACH5L — \$0037



**Figure 25-8. TIMA Channel Registers (TACH0H/L–TACH3H/L) (Sheet 3 of 3)**



## Timer Interface (TIMA-6)

## Section 26. Analog-to-Digital Converter (ADC-15)

**NOTE:** *This analog-to-digital converter (ADC) is for the J1850 (52-pin PLCC) protocol only.*

### 26.1 Contents

26.2	Introduction . . . . .	484
26.3	Features . . . . .	484
26.4	Functional Description . . . . .	484
26.4.1	ADC Port I/O Pins . . . . .	485
26.4.2	Voltage Conversion . . . . .	486
26.4.3	Conversion Time . . . . .	486
26.4.4	Continuous Conversion . . . . .	487
26.4.5	Accuracy and Precision . . . . .	487
26.5	Interrupts . . . . .	487
26.6	Low-Power Modes . . . . .	487
26.6.1	Wait Mode . . . . .	487
26.6.2	Stop Mode . . . . .	488
26.7	I/O Signals . . . . .	488
26.7.1	ADC Analog Power Pin ( $V_{DDAREF}$ )/ADC Voltage Reference Pin ( $V_{REFH}$ ) . . . . .	488
26.7.2	ADC Analog Ground Pin ( $V_{SSA}$ )/ADC Voltage Reference Low Pin ( $V_{REFL}$ ) . . . . .	488
26.7.3	ADC Voltage In (ADCVIN) . . . . .	488
26.8	I/O Registers . . . . .	489
26.8.1	ADC Status and Control Register . . . . .	489
26.8.2	ADC Data Register . . . . .	492
26.8.3	ADC Input Clock Register . . . . .	492

This section describes the analog-to-digital converter (ADC-15). The ADC is an 8-bit analog-to-digital converter.

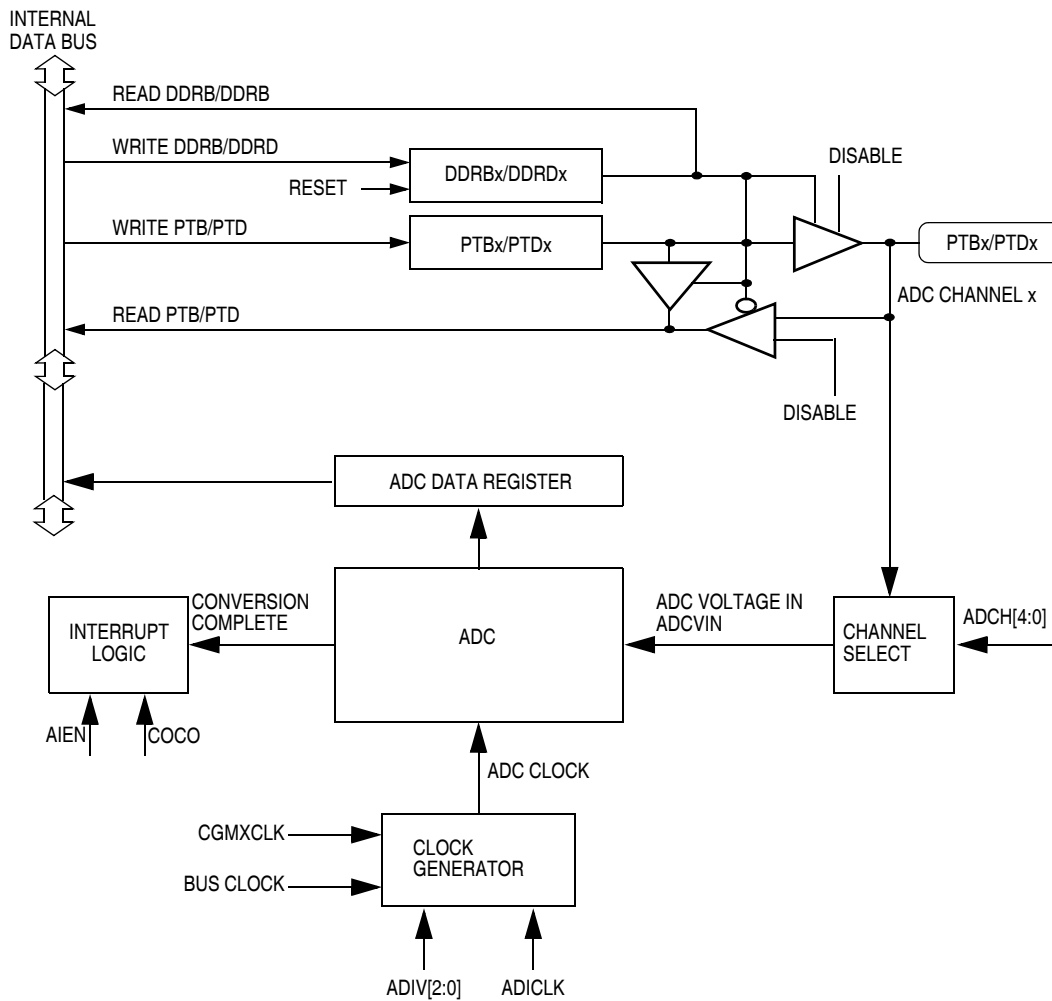
## 26.2 Features

Features of the ADC module include:

- 15 Channels with Multiplexed Input
- Linear Successive Approximation
- 8-Bit Resolution
- Single or Continuous Conversion
- Conversion Complete Flag or Conversion Complete Interrupt
- Selectable ADC Clock

## 26.3 Functional Description

Fifteen ADC channels are available for sampling external sources at pins PTD6/ATD14/TACLK–PTD0/ATD8 and PTB7/ATD7–PTB0/ATD0. An analog multiplexer allows the single ADC converter to select one of 15 ADC channels as ADC voltage in (ADCVIN). ADCVIN is converted by the successive approximation register-based counters. When the conversion is completed, ADC places the result in the ADC data register and sets a flag or generates an interrupt. (See [Figure 26-1](#).)



**Figure 26-1. ADC Block Diagram**

### 26.3.1 ADC Port I/O Pins

PTD6/ATD14/TACLK-PTD0/ATD8 and PTB7/ATD7-PTB0/ATD0 are general-purpose I/O pins that share with the ADC channels.

The channel select bits define which ADC channel/port pin will be used as the input signal. The ADC overrides the port I/O logic by forcing that pin as input to the ADC. The remaining ADC channels/port pins are controlled by the port I/O logic and can be used as general-purpose I/O. Writes to the port register or DDR will not have any effect on the port pin that is selected by the ADC. Read of a port pin which is in use by the

ADC will return a logic 0 if the corresponding DDR bit is at logic 0. If the DDR bit is at logic 1, the value in the port data latch is read.

**NOTE:** Do not use ADC channel ATD14 when using the PTD6/ATD14/TACLK pin as the clock input for the TIM.

## 26.3.2 Voltage Conversion

When the input voltage to the ADC equals  $V_{REFH}$  (see [29.7 ADC Characteristics](#)), the ADC converts the signal to \$FF (full scale). If the input voltage equals  $V_{SSA}$ , the ADC converts it to \$00. Input voltages between  $V_{REFH}$  and  $V_{SSA}$  are a straight-line linear conversion. All other input voltages will result in \$FF if greater than  $V_{REFH}$  and \$00 if less than  $V_{SSA}$ .

**NOTE:** Input voltage should not exceed the analog supply voltages.

## 26.3.3 Conversion Time

Conversion starts after a write to the ADSCR (ADC status control register, \$0038), and requires between 16 and 17 ADC clock cycles to complete. Conversion time in terms of the number of bus cycles is a function of ADICLK select, CGMXCLK frequency, bus frequency, and ADIV prescaler bits. For example, with a CGMXCLK frequency of 4 MHz, bus frequency of 8 MHz, and fixed ADC clock frequency of 1 MHz, one conversion will take between 16 and 17  $\mu$ s and there will be between 128 bus cycles between each conversion. Sample rate is approximately 60 kHz.

Refer to [29.7 ADC Characteristics](#).

$$\text{Conversion Time} = \frac{16 \text{ to } 17 \text{ ADC Clock Cycles}}{\text{ADC Clock Frequency}}$$

$$\text{Number of Bus Cycles} = \text{Conversion Time} \times \text{Bus Frequency}$$



### 26.3.4 Continuous Conversion

In the continuous conversion mode, the ADC data register will be filled with new data after each conversion. Data from the previous conversion will be overwritten whether that data has been read or not. Conversions will continue until the ADCO bit (ADC status control register, \$0038) is cleared. The COCO bit is set after the first conversion and will stay set for the next several conversions until the next write of the ADC status and control register or the next read of the ADC data register.

### 26.3.5 Accuracy and Precision

The conversion process is monotonic and has no missing codes. See [29.7 ADC Characteristics](#) for accuracy information.

## 26.4 Interrupts

When the AIEN bit is set, the ADC module is capable of generating a CPU interrupt after each ADC conversion. A CPU interrupt is generated if the COCO bit (ADC status control register, \$0038) is at logic 0. If the COCO bit is set, an interrupt is generated. The COCO bit is not used as a conversion complete flag when interrupts are enabled.

## 26.5 Low-Power Modes

The following subsections describe the low-power modes.

### 26.5.1 Wait Mode

The ADC continues normal operation during wait mode. Any enabled CPU interrupt request from the ADC can bring the MCU out of wait mode. If the ADC is not required to bring the MCU out of wait mode, power down the ADC by setting the ADCH[4:0] bits in the ADC status and control register before executing the WAIT instruction.

### 26.5.2 Stop Mode

The ADC module is inactive after the execution of a STOP instruction. Any pending conversion is aborted. ADC conversions resume when the MCU exits stop mode. Allow one conversion cycle to stabilize the analog circuitry before attempting a new ADC conversion after exiting stop mode.

## 26.6 I/O Signals

The ADC module has 15 channels that are shared with I/O ports B and D and one channel with an input-only port bit on port D. Refer to [29.7 ADC Characteristics](#) for voltages referenced below.

### 26.6.1 ADC Analog Power Pin ( $V_{DDAREF}$ )/ADC Voltage Reference Pin ( $V_{REFH}$ )

The ADC analog portion uses  $V_{DDAREF}$  as its power pin. Connect the  $V_{DDA}/V_{DDAREF}$  pin to the same voltage potential as  $V_{DD}$ . External filtering may be necessary to ensure clean  $V_{DDAREF}$  for good results.

$V_{REFH}$  is the high reference voltage for all analog-to-digital conversions. Connect the  $V_{REFH}$  pin to a voltage potential between 1.5 volts and  $V_{DDAREF}/V_{DDA}$  depending on the desired upper conversion boundary.

**NOTE:** Route  $V_{DDAREF}$  carefully for maximum noise immunity and place bypass capacitors as close as possible to the package.

### 26.6.2 ADC Analog Ground Pin ( $V_{SSA}$ )/ADC Voltage Reference Low Pin ( $V_{REFL}$ )

The ADC analog portion uses  $V_{SSA}$  as its ground pin. Connect the  $V_{SSA}$  pin to the same voltage potential as  $V_{SS}$ .

$V_{REFL}$  is the lower reference supply for the ADC.

### 26.6.3 ADC Voltage In (ADCVIN)

ADCVIN is the input voltage signal from one of the 15 ADC channels to the ADC module.

## 26.7 I/O Registers

These I/O registers control and monitor ADC operation:

- ADC status and control register (ADSCR)
- ADC data register (ADR)
- ADC clock register (ADICLK)

### 26.7.1 ADC Status and Control Register

The following paragraphs describe the function of the ADC status and control register.

Address: \$0038

	Bit 7	6	5	4	3	2	1	Bit 0
Read:	COCO	AIEN	ADCO	ADCH4	ADCH3	ADCH2	ADCH1	ADCH0
Write:	R							
Reset:	0	0	0	1	1	1	1	1

R = Reserved

**Figure 26-2. ADC Status and Control Register (ADSCR)**

#### COCO — Conversions Complete Bit

When the AIEN bit is a logic 0, the COCO is a read-only bit which is set each time a conversion is completed. This bit is cleared whenever the ADC status and control register is written or whenever the ADC data register is read.

If the AIEN bit is a logic 1, the COCO is a read/write bit which selects the CPU to service the ADC interrupt request. Reset clears this bit.

1 = Conversion completed (AIEN = 0)

0 = Conversion not completed (AIEN = 0)

or

1 = DMA interrupt enabled (AIEN = 1)

0 = CPU interrupt enabled (AIEN = 1)

### AIEN — ADC Interrupt Enable Bit

When this bit is set, an interrupt is generated at the end of an ADC conversion. The interrupt signal is cleared when the data register is read or the status/control register is written. Reset clears the AIEN bit.

- 1 = ADC interrupt enabled
- 0 = ADC interrupt disabled

### ADCO — ADC Continuous Conversion Bit

When set, the ADC will convert samples continuously and update the ADR register at the end of each conversion. Only one conversion is allowed when this bit is cleared. Reset clears the ADCO bit.

- 1 = Continuous ADC conversion
- 0 = One ADC conversion

### ADCH[4:0] — ADC Channel Select Bits

ADCH4, ADCH3, ADCH2, ADCH1, and ADCH0 form a 5-bit field which is used to select one of 15 ADC channels. The six channels are detailed in the following table. Care should be taken when using a port pin as both an analog and a digital input simultaneously to prevent switching noise from corrupting the analog signal. (See [Table 26-1](#).)

The ADC subsystem is turned off when the channel select bits are all set to one. This feature allows for reduced power consumption for the MCU when the ADC is not used. Reset sets these bits.

**NOTE:** *Recovery from the disabled state requires one conversion cycle to stabilize.*

**Table 26-1. Mux Channel Select**

ADCH4	ADCH3	ADCH2	ADCH1	ADCH0	Input Select
0	0	0	0	0	PTB0/ATD0
0	0	0	0	1	PTB1/ATD1
0	0	0	1	0	PTB2/ATD2
0	0	0	1	1	PTB3/ATD3
0	0	1	0	0	PTB4/ATD4
0	0	1	0	1	PTB5/ATD5
0	0	1	1	0	PTB6/ATD6
0	0	1	1	1	PTB7/ATD7
0	1	0	0	0	PTD0/ATD8
0	1	0	0	1	PTD1/ATD9
0	1	0	1	0	PTD2/ATD10
0	1	0	1	1	PTD3/ATD11
0	1	1	0	0	PTD4/ATD12/TBCLK
0	1	1	0	1	PTD5/ATD13
0	1	1	1	0	PTD6/ATD14/TACLK
Range 01111 (\$0F) to 11010 (\$1A)					Unused (see Note 1)
					Unused (see Note 1)
1	1	0	1	1	Reserved
1	1	1	0	0	$V_{DDA}/V_{DDAREF}$ (see Note 2)
1	1	1	0	1	$V_{REFH}$ (see Note 2)
1	1	1	1	0	$V_{SSA}/V_{REFL}$ (see Note 2)
1	1	1	1	1	[ADC power off]

**NOTES:**

1. If any unused channels are selected, the resulting ADC conversion will be unknown.
2. The voltage levels supplied from internal reference nodes as specified in the table are used to verify the operation of the ADC converter both in production test and for user applications.

## 26.7.2 ADC Data Register

One 8-bit result register is provided. This register is updated each time an ADC conversion completes.

Address: \$0039

	Bit 7	6	5	4	3	2	1	Bit 0
Read:	AD7	AD6	AD5	AD4	AD3	AD2	AD1	AD0
Write:	R	R	R	R	R	R	R	R
Reset:	Indeterminate after Reset							

R = Reserved

**Figure 26-3. ADC Data Register (ADR)**

## 26.7.3 ADC Input Clock Register

This register selects the clock frequency for the ADC.

Address: \$003A

	Bit 7	6	5	4	3	2	1	Bit 0
Read:	ADIV2	ADIV1	ADIV0	ADICLK	0	0	0	0
Write:					R	R	R	R
Reset:	0	0	0	0	0	0	0	0

R = Reserved

**Figure 26-4. ADC Input Clock Register (ADICLK)**

### ADIV2–ADIV0 — ADC Clock Prescaler Bits

ADIV2, ADIV1, and ADIV0 form a 3-bit field which selects the divide ratio used by the ADC to generate the internal ADC clock. [Table 26-2](#) shows the available clock configurations. The ADC clock should be set to approximately 1 MHz.

**Table 26-2. ADC Clock Divide Ratio**

ADIV2	ADIV1	ADIV0	ADC Clock Rate
0	0	0	ADC Input Clock / 1
0	0	1	ADC Input Clock / 2
0	1	0	ADC Input Clock / 4
0	1	1	ADC Input Clock / 8
1	X	X	ADC Input Clock / 16

X = don't care

#### ADICLK — ADC Input Clock Register Bit

ADICLK selects either bus clock or CGMXCLK as the input clock source to generate the internal ADC clock. Reset selects CGMXCLK as the ADC clock source.

If the external clock (CGMXCLK) is equal to or greater than 1 MHz, CGMXCLK can be used as the clock source for the ADC. If CGMXCLK is less than 1 MHz, use the PLL-generated bus clock as the clock source. As long as the internal ADC clock is at approximately 1 MHz, correct operation can be guaranteed. (See [29.7 ADC Characteristics](#).)

1 = Internal bus clock

0 = External clock (CGMXCLK)

$$1 \text{ MHz} = \frac{f_{\text{XCLK or Bus Frequency}}}{\text{ADIV}[2:0]}$$

**NOTE:** *During the conversion process, changing the ADC clock will result in an incorrect conversion.*



## Analog-to-Digital Converter (ADC-15)



## Section 27. MC68HC08AS20 Emulator Input/Output Ports

### 27.1 Contents

27.2	Introduction .....	496
27.3	Port A .....	498
27.3.1	Port A Data Register .....	498
27.3.2	Data Direction Register A .....	499
27.4	Port B .....	501
27.4.1	Port B Data Register .....	501
27.4.2	Data Direction Register B .....	502
27.5	Port C .....	504
27.5.1	Port C Data Register .....	504
27.5.2	Data Direction Register C .....	505
27.6	Port D .....	507
27.6.1	Port D Data Register .....	507
27.6.2	Data Direction Register D .....	508
27.7	Port E .....	510
27.7.1	Port E Data Register .....	510
27.7.2	Data Direction Register E .....	512
27.8	Port F .....	514
27.8.1	Port F Data Register .....	514
27.8.2	Data Direction Register F .....	515

## 27.2 Introduction

Forty bidirectional input/output (I/O) form six parallel ports. All I/O pins are programmable as inputs or outputs.

**NOTE:** Connect any unused I/O pins to an appropriate logic level, either  $V_{DD}$  or  $V_{SS}$ . Although the I/O ports do not require termination for proper operation, termination reduces excess current consumption and the possibility of electrostatic damage.

**Table 27-1. MC68HC08AS20 Emulator I/O Port Register Summary**

Addr.	Register Name	Bit 7	6	5	4	3	2	1	Bit 0	
\$0000	Port A Data Register (PTA)	Read:	PTA7	PTA6	PTA5	PTA4	PTA3	PTA2	PTA1	PTA0
		Write:								
		Reset:	Unaffected by Reset							
\$0001	Port B Data Register (PTB)	Read:	PTB7	PTB6	PTB5	PTB4	PTB3	PTB2	PTB1	PTB0
		Write:								
		Reset:	Unaffected by Reset							
\$0002	Port C Data Register (PTC)	Read:	0	0	<b>PTC5</b>	PTC4	PTC3	PTC2	PTC1	PTC0
		Write:	R	R						
		Reset:	Unaffected by Reset							
\$0003	Port D Data Register (PTD)	Read:	<b>PTD7</b>	PTD6	PTD5	PTD4	PTD3	PTD2	PTD1	PTD0
		Write:								
		Reset:	Unaffected by Reset							
\$0004	Data Direction Register A (DDRA)	Read:	DDRA7	DDRA6	DDRA5	DDRA4	DDRA3	DDRA2	DDRA1	DDRA0
		Write:								
		Reset:	0	0	0	0	0	0	0	0
\$0005	Data Direction Register B (DDRB)	Read:	DDRB7	DDRB6	DDRB5	DDRB4	DDRB3	DDRB2	DDRB1	DDRB0
		Write:								
		Reset:	0	0	0	0	0	0	0	0
\$0006	Data Direction Register C (DDRC)	Read:	MCLKEN	0	<b>DDRC5</b>	DDRC4	DDRC3	DDRC2	DDRC1	DDRC0
		Write:		R						
		Reset:	0	0	0	0	0	0	0	0

**Boldface Type** = MC68HC08AZ32 Specific

**Table 27-1. MC68HC08AS20 Emulator I/O Port Register Summary (Continued)**

Addr.	Register Name	Bit 7	6	5	4	3	2	1	Bit 0	
\$0007	Data Direction Register D (DDR D)	Read:	DDR D7	DDR D6	DDR D5	DDR D4	DDR D3	DDR D2	DDR D1	DDR D0
		Write:								
		Reset:	0	0	0	0	0	0	0	0
\$0008	Port E Data Register (PTE)	Read:	PTE7	PTE6	PTE5	PTE4	PTE3	PTE2	PTE1	PTE0
		Write:								
		Reset:	Unaffected by Reset							
\$0009	Port F Data Register (PTF)	Read:	0	PTF6	PTF5	PTF4	PTF3	PTF2	PTF1	PTF0
		Write:	R							
		Reset:	Unaffected by Reset							
\$000A	Port G Data Register (PTG)	Read:	0	0	0	0	0	PTG2	PTG1	PTG0
		Write:	R	R	R	R	R			
		Reset:	Unaffected by Reset							
\$000B	Port H Data Register (PTH)	Read:	0	0	0	0	0	PTH1	PTH0	
		Write:	R	R	R	R	R			
		Reset:	Unaffected by Reset							
\$000C	Data Direction Register E (DDRE)	Read:	DDRE7	DDRE6	DDRE5	DDRE4	DDRE3	DDRE2	DDRE1	DDRE0
		Write:								
		Reset:	0	0	0	0	0	0	0	0
\$000D	Data Direction Register F (DDRF)	Read:	0	DDRF6	DDRF5	DDRF4	DDRF3	DDRF2	DDRF1	DDRF0
		Write:	R							
		Reset:	0	0	0	0	0	0	0	0

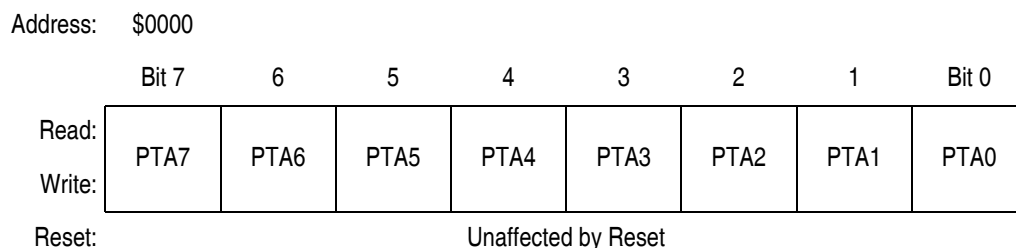
**Boldface Type = MC68HC08AZ32 Specific**

## 27.3 Port A

Port A is an 8-bit general-purpose bidirectional I/O port.

### 27.3.1 Port A Data Register

The port A data register contains a data latch for each of the eight port A pins.



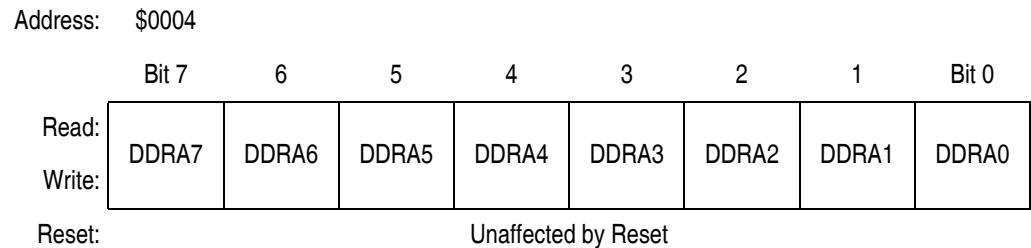
**Figure 27-1. Port A Data Register (PTA)**

#### PTA[7:0] — Port A Data Bits

These read/write bits are software programmable. Data direction of each port A pin is under the control of the corresponding bit in data direction register A. Reset has no effect on port A data.

### 27.3.2 Data Direction Register A

Data direction register A determines whether each port A pin is an input or an output. Writing a logic 1 to a DDRA bit enables the output buffer for the corresponding port A pin; a logic 0 disables the output buffer.



**Figure 27-2. Data Direction Register A (DDRA)**

#### DDRA[7:0] — Data Direction Register A Bits

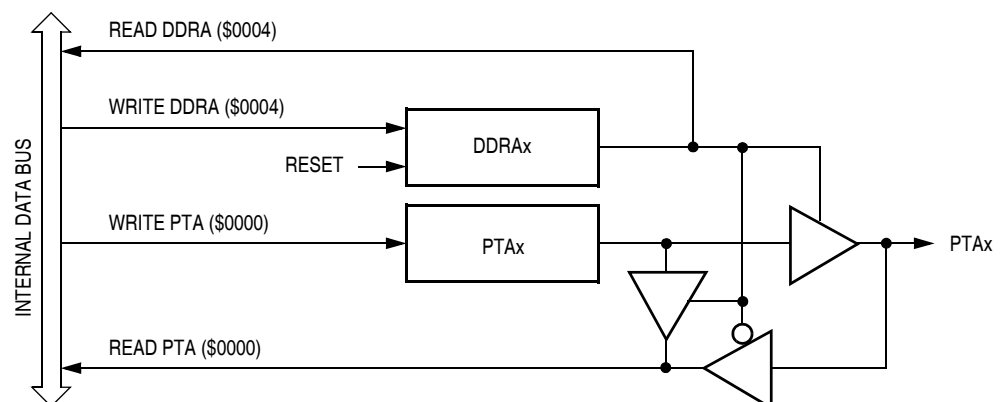
These read/write bits control port A data direction. Reset clears DDRA[7:0], configuring all port A pins as inputs.

1 = Corresponding port A pin configured as output

0 = Corresponding port A pin configured as input

**NOTE:** Avoid glitches on port A pins by writing to the port A data register before changing data direction register A bits from 0 to 1.

Figure 27-3 shows the port A I/O logic.



**Figure 27-3. Port A I/O Circuit**

When bit DDRAx is a logic 1, reading address \$0000 reads the PTAx data latch. When bit DDRAx is a logic 0, reading address \$0000 reads the voltage level on the pin. The data latch can always be written, regardless of the state of its data direction bit. [Table 27-2](#) summarizes the operation of the port A pins.

**Table 27-2. Port A Pin Functions**

DDRA Bit	PTA Bit	I/O Pin Mode	Accesses to DDRA	Accesses to PTA	
			Read/Write	Read	Write
0	X	Input, Hi-Z	DDRA[7:0]	Pin	PTA[7:0] <sup>(1)</sup>
1	X	Output	DDRA[7:0]	PTA[7:0]	PTA[7:0]

X = don't care

Hi-Z = high impedance

1. Writing affects data register, but does not affect input.

## 27.4 Port B

Port B is an 8-bit special-function port that shares all of its pins with the analog-to-digital converter.

### 27.4.1 Port B Data Register

The port B data register contains a data latch for each of the eight port B pins.

Address: \$0001

	Bit 7	6	5	4	3	2	1	Bit 0
Read:	PTB7	PTB6	PTB5	PTB4	PTB3	PTB2	PTB1	PTB0
Write:	PTB7	PTB6	PTB5	PTB4	PTB3	PTB2	PTB1	PTB0
Reset:	Unaffected by Reset							
Alternate Functions:	ATD7	ATD6	ATD5	ATD4	ATD3	ATD2	ATD1	ATD0

**Figure 27-4. Port B Data Register (PTB)**

#### PTB[7:0] — Port B Data Bits

These read/write bits are software programmable. Data direction of each port B pin is under the control of the corresponding bit in data direction register B. Reset has no effect on port B data.

#### ATD[7:0] — ADC Channels

PTB7/ATD7–PTB0/ATD0 are eight of the 15 analog-to-digital converter channels. The ADC channel select bits, CH[4:0], determine whether the PTB7/ATD7–PTB0/ATD0 pins are ADC channels or general-purpose I/O pins. If an ADC channel is selected and a read of this corresponding bit in the port B data register occurs, the data will be 0 if the data direction for this bit is programmed as an input. Otherwise, the data will reflect the value in the data latch. (See [Section 26. Analog-to-Digital Converter \(ADC-15\)](#).) Data direction register B (DDRB) does not affect the data direction of port B pins that are being used by the ADC. However, the DDRB bits always determine whether reading port B returns to the states of the latches or logic 0.

## 27.4.2 Data Direction Register B

Data direction register B determines whether each port B pin is an input or an output. Writing a logic 1 to a DDRB bit enables the output buffer for the corresponding port B pin; a logic 0 disables the output buffer.

Address: \$0005

	Bit 7	6	5	4	3	2	1	Bit 0
Read:	DDRB7	DDRB6	DDRB5	DDRB4	DDRB3	DDRB2	DDRB1	DDRB0
Write:								
Reset:	0	0	0	0	0	0	0	0

**Figure 27-5. Data Direction Register B (DDRB)**

### DDRB[7:0] — Data Direction Register B Bits

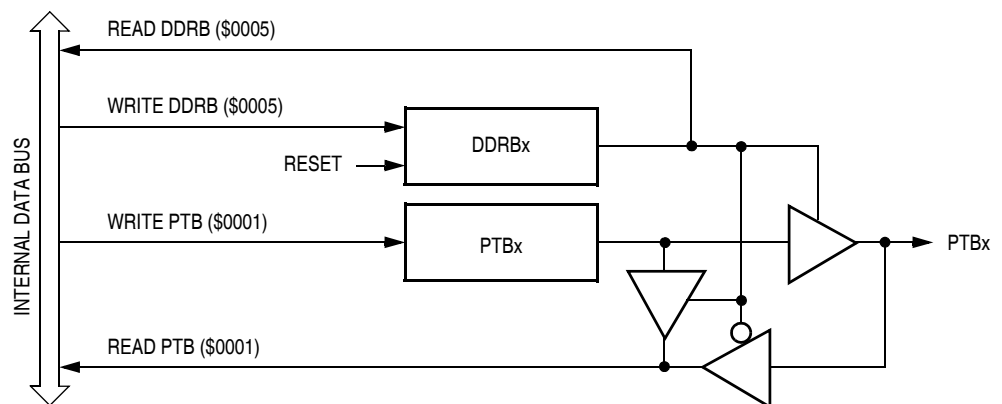
These read/write bits control port B data direction. Reset clears DDRB[7:0], configuring all port B pins as inputs.

1 = Corresponding port B pin configured as output

0 = Corresponding port B pin configured as input

**NOTE:** *Avoid glitches on port B pins by writing to the port B data register before changing data direction register B bits from 0 to 1.*

Figure 27-6 shows the port B I/O logic.



**Figure 27-6. Port B I/O Circuit**



When bit DDRBx is a logic 1, reading address \$0001 reads the PTBx data latch. When bit DDRBx is a logic 0, reading address \$0001 reads the voltage level on the pin. The data latch can always be written, regardless of the state of its data direction bit. **Table 27-3** summarizes the operation of the port B pins.

**Table 27-3. Port B Pin Functions**

DDR B Bit	PTB Bit	I/O Pin Mode	Accesses to DDRB	Accesses to PTB	
			Read/Write	Read	Write
0	X	Input, Hi-Z	DDR B[7:0]	Pin	PTB[7:0] <sup>(1)</sup>
1	X	Output	DDR B[7:0]	PTB[7:0]	PTB[7:0]

X = don't care

Hi-Z = high impedance

1. Writing affects data register, but does not affect input.

## 27.5 Port C

Port C is an 5-bit general-purpose bidirectional I/O port.

### 27.5.1 Port C Data Register

The port C data register contains a data latch for each of the five port C pins.

Address: \$0002

	Bit 7	6	5	4	3	2	1	Bit 0
Read:	0	0	0	PTC4	PTC3	PTC2	PTC1	PTC0
Write:	R	R	R					
Reset:	Unaffected by Reset							
	R		= Reserved					
Alternate Functions:	R	R	R	R	R	MCLK	R	R

**Figure 27-7. Port C Data Register (PTC)**

#### PTC[4:0] — Port C Data Bits

These read/write bits are software-programmable. Data direction of each port C pin is under the control of the corresponding bit in data direction register C. Reset has no effect on port C data.

#### MCLK — T12 System Clock Bit

The system clock is driven out of PTC2 when enabled by MCLKEN bit in PTCDDR7.

## 27.5.2 Data Direction Register C

Data direction register C determines whether each port C pin is an input or an output. Writing a logic 1 to a DDRC bit enables the output buffer for the corresponding port C pin; a logic 0 disables the output buffer.

Address: \$0006

	Bit 7	6	5	4	3	2	1	Bit 0
Read:	MCLKEN	0	0	DDRC4	DDRC3	DDRC2	DDRC1	DDRC0
Write:	MCLKEN	R	R	DDRC4	DDRC3	DDRC2	DDRC1	DDRC0
Reset:	0	0	0	0	0	0	0	0

R = Reserved

**Figure 27-8. Data Direction Register C (DDRC)**

### MCLKEN — MCLK Enable Bit

This read/write bit enables MCLK to be an output signal on PTC2. If MCLK is enabled, PTC2 is under the control of MCLKEN. Reset clears this bit.

- 1 = MCLK output enabled
- 0 = MCLK output disabled

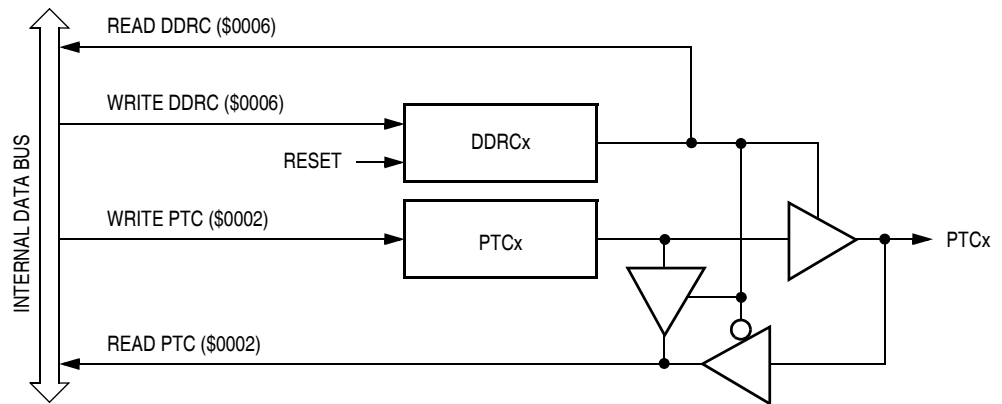
### DDRC[4:0] — Data Direction Register C Bits

These read/write bits control port C data direction. Reset clears DDRC[7:0], configuring all port C pins as inputs.

- 1 = Corresponding port C pin configured as output
- 0 = Corresponding port C pin configured as input

**NOTE:** *Avoid glitches on port C pins by writing to the port C data register before changing data direction register C bits from 0 to 1.*

**Figure 27-9** shows the port C I/O logic.



**Figure 27-9. Port C I/O Circuit**

When bit DDRCx is a logic 1, reading address \$0002 reads the PTCx data latch. When bit DDRCx is a logic 0, reading address \$0002 reads the voltage level on the pin. The data latch can always be written, regardless of the state of its data direction bit. [Table 27-4](#) summarizes the operation of the port C pins.

**Table 27-4. Port C Pin Functions**

DDRC Bit	PTC Bit	I/O Pin Mode	Accesses to DDRC	Accesses to PTC	
			Read/Write	Read	Write
0	2	Input, Hi-Z	DDRC[7]	Pin	PTC2
1	2	Output	DDRC[7]	0	—
0	X	Input, Hi-Z	DDRC[4:0]	Pin	PTC[4:0] <sup>(1)</sup>
1	X	Output	DDRC[4:0]	PTC[4:0]	PTC[4:0]

X = don't care

Hi-Z = high impedance

1. Writing affects data register, but does not affect input.

## 27.6 Port D

Port D is an 8-bit general-purpose I/O port.

### 27.6.1 Port D Data Register

Port D is a 7-bit special function port that shares all of its pins with the analog-to-digital converter and one of its pins with the aaf.

Address: \$0003

	Bit 7	6	5	4	3	2	1	Bit 0
Read:	0	PTD6	PTD5	PTD4	PTD3	PTD2	PTD1	PTD0
Write:	R							
Reset:	Unaffected by Reset							
Alternate Functions:	R	ATD14/TACLK	ATD13	ATD12	ATD11	ATD10	ATD9	ATD8

R
---

 = Reserved

**Figure 27-10. Port D Data Register (PTD)**

#### PTD[6:0] — Port D Data Bits

PTD[6:0] are read/write, software programmable bits. Data direction of PTD[6:0] pins are under the control of the corresponding bit in data direction register D.

#### ATD[14:8] — ADC Channel Status Bits

PTD6/ATD14/TACLK–PTD0/ATD8 are seven of the 15 analog-to-digital converter channels. The ADC channel select bits, CH[4:0], determine whether the PTD6/ATD14/TACLK–PTD0/ATD8 pins are ADC channels or general-purpose I/O pins. If an ADC channel is selected and a read of this corresponding bit in the port B data register occurs, the data will be 0 if the data direction for this bit is programmed as an input. Otherwise, the data will reflect the value in the data latch. (See [Section 26. Analog-to-Digital Converter \(ADC-15\)](#).)

**NOTE:** Data direction register D (DDRD) does not affect the data direction of port D pins that are being used by the ADC. However, the DDRD bits always determine whether reading port D returns the states of the latches or logic 0.

### TACLK — Timer Clock Input Bit

The PTD6/ATD14/TACLK pin is the external clock input for the TIMA. The prescaler select bits, PS[2:0], select PTD6/ATD14/TACLK as the TIMA clock input. (See [25.9.1 TIMA Status and Control Register](#).) When not selected as the TIMA clock, PTD6/ATD14/TACLK is available for general-purpose I/O or as an ADC channel.

**NOTE:** Do not use ADC channel ATD14 when using the PTD6/ATD14/TACLK pin as the clock input for the TIMA.

## 27.6.2 Data Direction Register D

Data direction register D determines whether each port D pin is an input or an output. Writing a logic 1 to a DDRD bit enables the output buffer for the corresponding port D pin; a logic 0 disables the output buffer.

Address: \$0007

	Bit 7	6	5	4	3	2	1	Bit 0
Read:	0	DDRD6	DDRD5	DDRD4	DDRD3	DDRD2	DDRD1	DDRD0
Write:	0							
Reset:	0	0	0	0	0	0	0	0

**Figure 27-11. Data Direction Register D (DDRD)**

### DDRD[6:0] — Data Direction Register D Bits

These read/write bits control port D data direction. Reset clears DDRD[6:0], configuring all port D pins as inputs.

1 = Corresponding port D pin configured as output

0 = Corresponding port D pin configured as input

**NOTE:** Avoid glitches on port D pins by writing to the port D data register before changing data direction register D bits from 0 to 1.

Figure 27-12 shows the port D I/O logic.

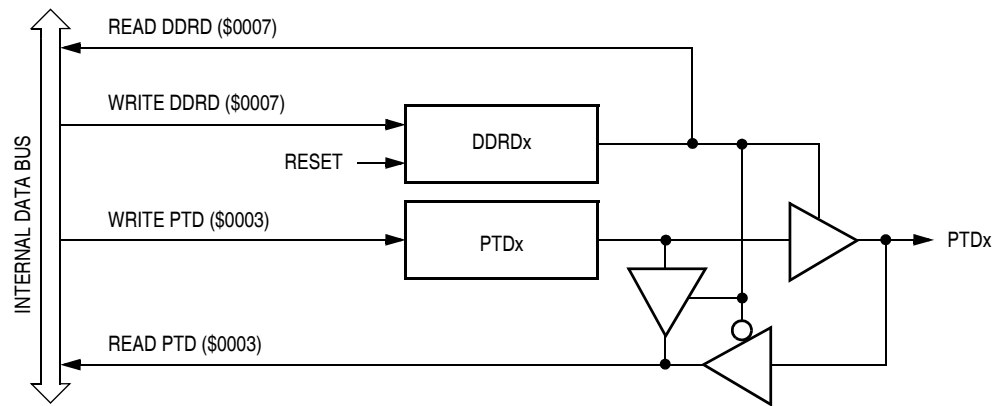


Figure 27-12. Port D I/O Circuit

When bit DDRDx is a logic 1, reading address \$0003 reads the PTDx data latch. When bit DDRDx is a logic 0, reading address \$0003 reads the voltage level on the pin. The data latch can always be written, regardless of the state of its data direction bit. Table 27-5 summarizes the operation of the port D pins.

Table 27-5. Port D Pin Functions

DDRD Bit	PTD Bit	I/O Pin Mode	Accesses to DDRD	Accesses to PTD	
			Read/Write	Read	Write
0	X	Input, Hi-Z	DDRD[6:0]	Pin	PTD[6:0] <sup>(1)</sup>
1	X	Output	DDRD[6:0]	PTD[6:0]	PTD[6:0]

X = don't care

Hi-Z = high impedance

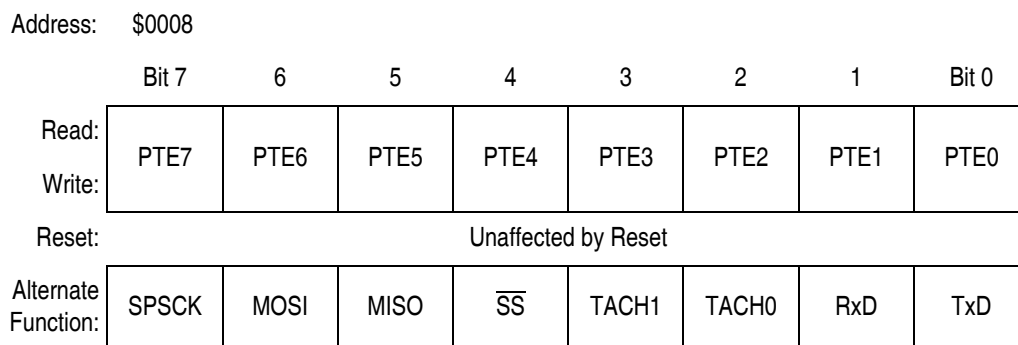
1. Writing affects data register, but does not affect input.

## 27.7 Port E

Port E is an 8-bit special function port that shares two of its pins with the timer interface module (TIMA), two of its pins with the serial communications interface module (SCI), and four of its pins with the serial peripheral interface module (SPI).

### 27.7.1 Port E Data Register

The port E data register contains a data latch for each of the eight port E pins.



**Figure 27-13. Port E Data Register (PTE)**

#### PTE[7:0] — Port E Data Bits

PTE[7:0] are read/write, software programmable bits. Data direction of each port E pin is under the control of the corresponding bit in data direction register E.

#### SPSCK — SPI Serial Clock Bit

The PTE7/SPSCK pin is the serial clock input of an SPI slave module and serial clock output of an SPI master module. When the SPE bit is clear, the PTE7/SPSCK pin is available for general-purpose I/O.

#### MOSI — Master Out/Slave In Bit

The PTE6/MOSI pin is the master out/slave in terminal of the SPI module. When the SPE bit is clear, the PTE6/MOSI pin is available for general-purpose I/O. (See [17.14.1 SPI Control Register](#).)



### MISO — Master In/Slave Out Bit

The PTE5/MISO pin is the master in/slave out terminal of the SPI module. When the SPI enable bit, SPE, is clear, the SPI module is disabled, and the PTE5/MISO pin is available for general-purpose I/O. (See [17.14.1 SPI Control Register](#).)

### $\overline{SS}$ — Slave Select Bit

The PTE4/ $\overline{SS}$  pin is the slave select input of the SPI module. When the SPE bit is clear, or when the SPI master bit, SPMSTR, is set and MODFEN bit is low, the PTE4/ $\overline{SS}$  pin is available for general-purpose I/O. (See [17.13.4 SS \(Slave Select\)](#).) When the SPI is enabled as a slave, the DDRF4 bit in data direction register E (DDRE) has no effect on the PTE4/ $\overline{SS}$  pin.

**NOTE:** *Data direction register E (DDRE) does not affect the data direction of port E pins that are being used by the SPI module. However, the DDRE bits always determine whether reading port E returns the states of the latches or the states of the pins. (See [Table 27-6](#).)*

### TACH[1:0] — Timer Channel I/O Bits

The PTE3/TACH1–PTE2/TACH0 pins are the TIMA input capture/output compare pins. The edge/level select bits, ELSxB–ELSxA, determine whether the PTE3/TACH1–PTE2/TACH0 pins are timer channel I/O pins or general-purpose I/O pins. (See [25.9.4 TIMA Channel Status and Control Registers](#).)

**NOTE:** *Data direction register E (DDRE) does not affect the data direction of port E pins that are being used by the TIMA. However, the DDRE bits always determine whether reading port E returns the states of the latches or the states of the pins. (See [Table 27-6](#).)*

### RxD — SCI Receive Data Input Bit

The PTE1/RxD pin is the receive data input for the SCI module. When the enable SCI bit, ENSCI, is clear, the SCI module is disabled, and the PTE1/RxD pin is available for general-purpose I/O. (See [16.9.1 SCI Control Register 1](#).)

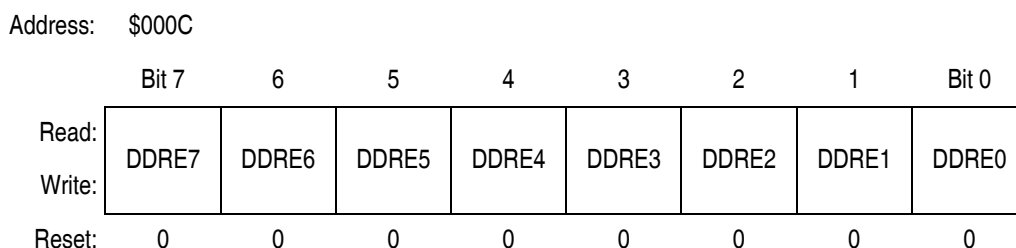
## TxD — SCI Transmit Data Output

The PTE0/TxD pin is the transmit data output for the SCI module. When the enable SCI bit, ENSCI, is clear, the SCI module is disabled, and the PTE0/TxD pin is available for general-purpose I/O. (See [16.9.1 SCI Control Register 1](#).)

**NOTE:** *Data direction register E (DDRE) does not affect the data direction of port E pins that are being used by the SCI module. However, the DDRE bits always determine whether reading port E returns the states of the latches or the states of the pins. (See [Table 27-6](#).)*

## 27.7.2 Data Direction Register E

Data direction register E determines whether each port E pin is an input or an output. Writing a logic 1 to a DDRE bit enables the output buffer for the corresponding port E pin; a logic 0 disables the output buffer.



**Figure 27-14. Data Direction Register E (DDRE)**

### DDRE[7:0] — Data Direction Register E Bits

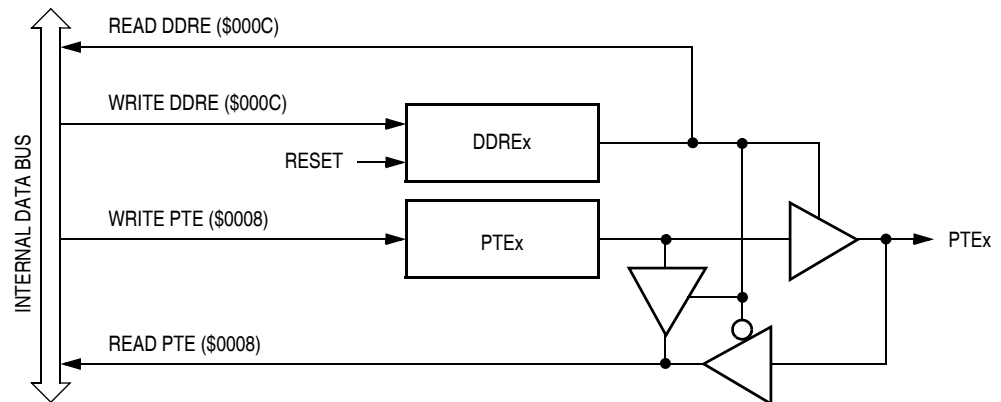
These read/write bits control port E data direction. Reset clears DDRE[7:0], configuring all port E pins as inputs.

1 = Corresponding port E pin configured as output

0 = Corresponding port E pin configured as input

**NOTE:** *Avoid glitches on port E pins by writing to the port E data register before changing data direction register E bits from 0 to 1.*

[Figure 27-15](#) shows the port E I/O logic.



**Figure 27-15. Port E I/O Circuit**

When bit DDREx is a logic 1, reading address \$0008 reads the PTE<sub>x</sub> data latch. When bit DDREx is a logic 0, reading address \$0008 reads the voltage level on the pin. The data latch can always be written, regardless of the state of its data direction bit. [Table 27-6](#) summarizes the operation of the port E pins.

**Table 27-6. Port E Pin Functions**

DDRE Bit	PTE Bit	I/O Pin Mode	Accesses to DDRE	Accesses to PTE	
			Read/Write	Read	Write
0	X	Input, Hi-Z	DDRE[7:0]	Pin	PTE[7:0] <sup>(1)</sup>
1	X	Output	DDRE[7:0]	PTE[7:0]	PTE[7:0]

X = don't care

Hi-Z = high impedance

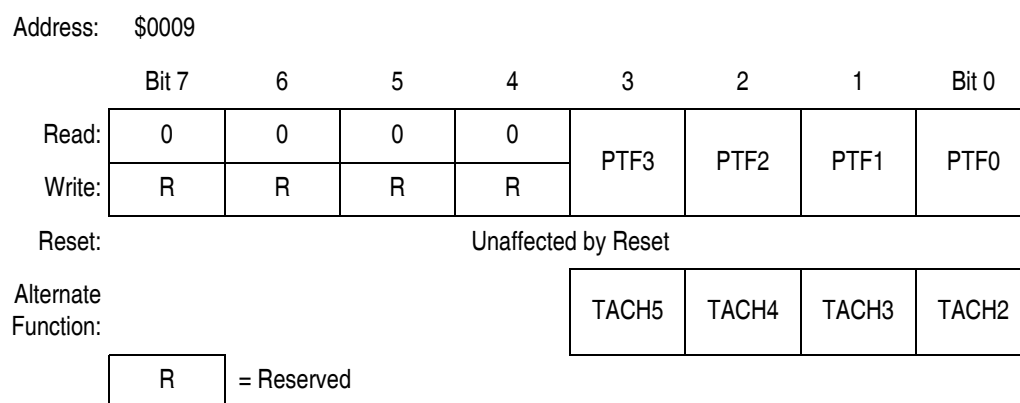
1. Writing affects data register, but does not affect input.

## 27.8 Port F

Port F is a 4-bit special function port that shares four of its pins with the timer interface module (TIMA).

### 27.8.1 Port F Data Register

The port F data register contains a data latch for each of the six port F pins.



**Figure 27-16. Data Direction Register E (DDRE)**

#### PTF[3:0] — Port F Data Bits

These read/write bits are software programmable. Data direction of each port F pin is under the control of the corresponding bit in data direction register F. Reset has no effect on PTF[3:0].

#### TACH[5:2] — Timer Channel I/O Bits

The PTF3/TACH5–PTF0/TACH2 pins are the TIMA input capture/output compare pins. The edge/level select bits, ELSxB–ELSxA, determine whether the PTF3/TACH5–PTF0/TACH2 pins are timer channel I/O pins or general-purpose I/O pins. (See [25.9.4 TIMA Channel Status and Control Registers.](#))

**NOTE:** *Data direction register F (DDRF) does not affect the data direction of port F pins that are being used by the TIMA. However, the DDRF bits always determine whether reading port F returns the states of the latches or the states of the pins. (See [Table 27-7.](#))*

## 27.8.2 Data Direction Register F

Data direction register F determines whether each port F pin is an input or an output. Writing a logic 1 to a DDRF bit enables the output buffer for the corresponding port F pin; a logic 0 disables the output buffer.

Address: \$000D

	Bit 7	6	5	4	3	2	1	Bit 0
Read:	0	0	0	0	DDRF3	DDRF2	DDRF1	DDRF0
Write:	R	R	R	R				
Reset:	0	0	0	0	0	0	0	0

R = Reserved

**Figure 27-17. Data Direction Register F (DDRF)**

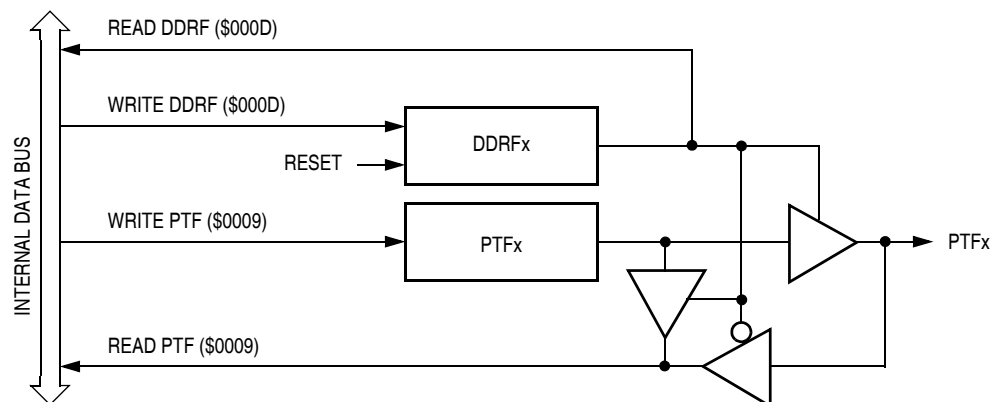
### DDRF[3:0] — Data Direction Register F Bits

These read/write bits control port F data direction. Reset clears DDRF[3:0], configuring all port F pins as inputs.

- 1 = Corresponding port F pin configured as output
- 0 = Corresponding port F pin configured as input

**NOTE:** Avoid glitches on port F pins by writing to the port F data register before changing data direction register F bits from 0 to 1.

Figure 27-18 shows the port F I/O logic.



**Figure 27-18. Port F I/O Circuit**

When bit DDRF<sub>x</sub> is a logic 1, reading address \$0009 reads the PTF<sub>x</sub> data latch. When bit DDRF<sub>x</sub> is a logic 0, reading address \$0009 reads the voltage level on the pin. The data latch can always be written, regardless of the state of its data direction bit. [Table 27-7](#) summarizes the operation of the port F pins.

**Table 27-7. Port F Pin Functions**

DDRF Bit	PTF Bit	I/O Pin Mode	Accesses to DDRF	Accesses to PTF	
			Read/Write	Read	Write
0	X	Input, Hi-Z	DDRF[3:0]	Pin	PTF[3:0] <sup>(1)</sup>
1	X	Output	DDRF[3:0]	PTF[3:0]	PTF[3:0]

X = don't care

Hi-Z = high impedance

1. Writing affects data register, but does not affect input.

## Section 28. Byte Data Link Controller–Digital (BDLC–D)

### 28.1 Contents

20.2	Introduction . . . . .	519
20.3	Features . . . . .	519
20.4	Functional Description . . . . .	520
20.4.1	BDLC Operating Modes . . . . .	522
20.4.1.1	Power Off Mode . . . . .	522
20.4.1.2	Reset Mode . . . . .	523
20.4.1.3	Run Mode . . . . .	523
20.4.1.4	BDLC Wait Mode . . . . .	523
20.4.1.5	BDLC Stop Mode . . . . .	524
20.4.1.6	Digital Loopback Mode . . . . .	524
20.4.1.7	Analog Loopback Mode . . . . .	524
20.5	BDLC MUX Interface . . . . .	525
20.5.1	Rx Digital Filter . . . . .	526
20.5.1.1	Operation . . . . .	526
20.5.1.2	Performance . . . . .	527
20.5.2	J1850 Frame Format . . . . .	528
20.5.3	J1850 VPW Symbols . . . . .	531
20.5.4	J1850 VPW Valid/Invalid Bits and Symbols . . . . .	534
20.5.5	Message Arbitration . . . . .	538
20.6	BDLC Protocol Handler . . . . .	540
20.6.1	Protocol Architecture . . . . .	541
20.6.2	Rx and Tx Shift Registers . . . . .	541
20.6.3	Rx and Tx Shadow Registers . . . . .	542
20.6.4	Digital Loopback Multiplexer . . . . .	542
20.6.5	State Machine . . . . .	542
20.6.5.1	4X Mode . . . . .	542
20.6.5.2	Receiving a Message in Block Mode . . . . .	543
20.6.5.3	Transmitting a Message in Block Mode . . . . .	543



## Byte Data Link Controller–Digital (BDLC–D)

20.6.5.4	J1850 Bus Errors . . . . .	543
20.6.5.5	Summary . . . . .	545
20.7	BDLC CPU Interface . . . . .	546
20.7.1	BDLC Analog and Roundtrip Delay . . . . .	546
20.7.2	BDLC Control Register 1 . . . . .	548
20.7.3	BDLC Control Register 2 . . . . .	551
20.7.4	BDLC State Vector Register . . . . .	558
20.7.5	BDLC Data Register . . . . .	561
20.8	Low-Power Modes . . . . .	562
20.8.1	Wait Mode . . . . .	562
20.8.2	Stop Mode . . . . .	562



## 28.2 Introduction

The byte data link controller (BDLC) provides access to an external serial communication multiplex bus, operating according to the SAE J1850 protocol.

## 28.3 Features

Features of the BDLC module include:

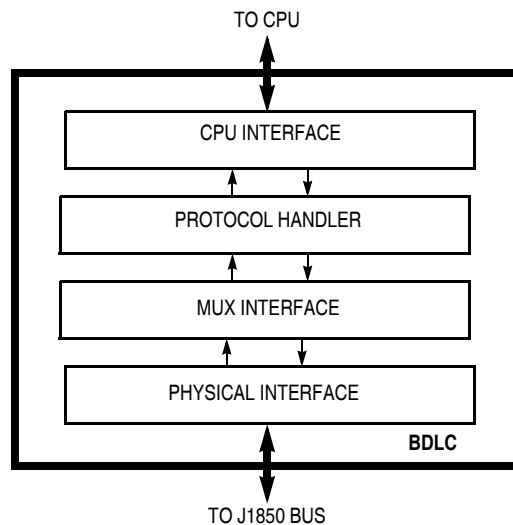
- *SAE J1850 Class B Data Communications Network Interface* Compatible and ISO Compatible for Low-Speed ( $\leq 125$  kbps) Serial Data Communications in Automotive Applications
- 10.4 kbps Variable Pulse Width (VPW) Bit Format
- Digital Noise Filter
- Collision Detection
- Hardware Cyclical Redundancy Check (CRC) Generation and Checking
- Two Power-Saving Modes with Automatic Wakeup on Network Activity
- Polling or CPU Interrupts
- Block Mode Receive and Transmit Supported
- 4X Receive Mode, 41.6 kbps, Supported
- Digital Loopback Mode
- Analog Loopback Mode
- In-Frame Response (IFR) Types 0, 1, 2, and 3 Supported

## 28.4 Functional Description

**Figure 28-1** shows the organization of the BDLC module. The CPU interface contains the software addressable registers and provides the link between the CPU and the buffers. The buffers provide storage for data received and data to be transmitted onto the J1850 bus. The protocol handler is responsible for the encoding and decoding of data bits and special message symbols during transmission and reception. The MUX interface provides the link between the BDLC digital section and the analog physical interface. The wave shaping, driving, and digitizing of data is performed by the physical interface.

Use of the BDLC module in message networking fully implements the *SAE Standard J1850 Class B Data Communication Network Interface* specification.

**NOTE:** *It is recommended that the reader be familiar with the SAE J1850 document and ISO Serial Communication document prior to proceeding with this section of the MC68HC08AS20 specification.*



**Figure 28-1. BDLC Block Diagram**

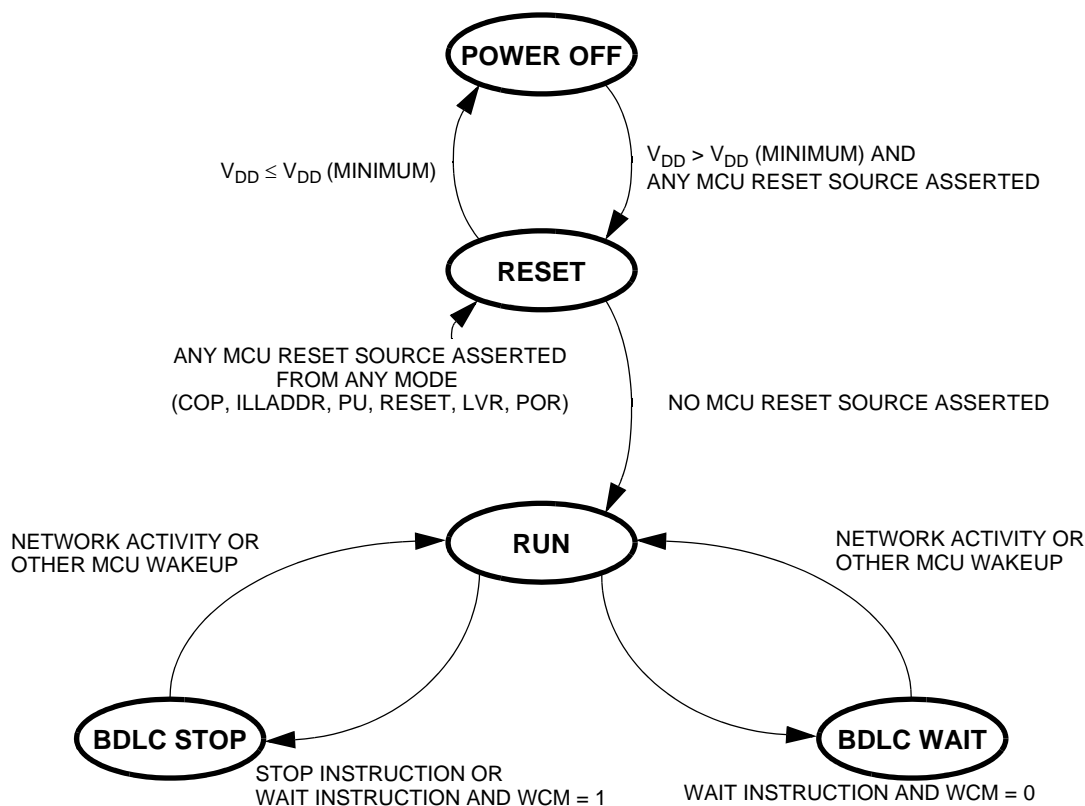
**Table 28-1. BDLC Input/Output (I/O) Register Summary**

Addr.	Name		Bit 7	6	5	4	3	2	1	Bit 0
\$003B	BDLC Analog and Roundtrip Delay Register (BARD)	Read:			0	0				
		Write:	ATE	RXPOL			BO3	BO2	BO1	BO0
		Reset:	1	1	0	0	0	1	1	1
\$003C	BDLC Control Register 1 (BCR1)	Read:	IMSG	CLKS	R1	R0	0	0	IE	WCM
		Write:					R	R		
		Reset:	1	1	1	0	0	0	0	0
\$003D	BDLC Control Register 2 (BCR2)	Read:	ALOOP	DLOOP	RX4XE	NBFS	TEOD	TSIFR	TMIFR1	TMIFR0
		Write:								
		Reset:	1	1	0	0	0	0	0	0
\$003E	BDLC State Vector Register (BSVR)	Read:	0	0	I3	I2	I1	I0	0	0
		Write:								
		Reset:	0	0	0	0	0	0	0	0
\$003F	BDLC Data Register (BDR)	Read:	BD7	BD6	BD5	BD4	BD3	BD2	BD1	BD0
		Write:								
		Reset:	Indeterminate after Reset							

= Unimplemented    
 R = Reserved

## 28.4.1 BDLC Operating Modes

The BDLC has five main modes of operation which interact with the power supplies, pins, and rest of the MCU as shown in [Figure 28-2](#).



**Figure 28-2. BDLC Operating Modes State Diagram**

### 28.4.1.1 Power Off Mode

For the BDLC to guarantee operation, this mode is entered from reset mode whenever the BDLC supply voltage,  $V_{DD}$ , drops below its minimum specified value. The BDLC will be placed in reset mode by low-voltage reset (LVR) before being powered down. In power off mode, the pin input and output specifications are not guaranteed.

### 28.4.1.2 Reset Mode

This mode is entered from power off mode whenever the BDLC supply voltage,  $V_{DD}$ , rises above its minimum specified value ( $V_{DD} - 10\%$ ) and some MCU reset source is asserted. The internal MCU reset must be asserted while powering up the BDLC or an unknown state will be entered and correct operation cannot be guaranteed. Reset mode is also entered from any other mode as soon as one of the MCU's possible reset sources (such as LVR, POR, COP watchdog, reset pin, etc.) is asserted.

In reset mode, the internal BDLC voltage references are operative,  $V_{DD}$  is supplied to the internal circuits which are held in their reset state, and the internal BDLC system clock is running. Registers will assume their reset condition. Because outputs are held in their programmed reset state, inputs and network activity are ignored.

### 28.4.1.3 Run Mode

This mode is entered from reset mode after all MCU reset sources are no longer asserted. Run mode is entered from the BDLC wait mode whenever activity is sensed on the J1850 bus.

Run mode is entered from the BDLC stop mode whenever network activity is sensed, although messages will not be received properly until the clocks have stabilized and the CPU is also in run mode.

In this mode, normal network operation takes place. The user should ensure that all BDLC transmissions have ceased before exiting this mode.

### 28.4.1.4 BDLC Wait Mode

This power-conserving mode is entered automatically from run mode whenever the CPU executes a WAIT instruction and if the WCM bit in the BCR1 register is cleared previously.

In this mode, the BDLC internal clocks continue to run. The first passive-to-active transition of the bus generates a CPU interrupt request from the BDLC, which wakes up the BDLC and the CPU. In addition, if the BDLC

receives a valid end-of-frame (EOF) symbol while operating in wait mode, then the BDLC also will generate a CPU interrupt request, which wakes up the BDLC and the CPU. See [28.8.1 Wait Mode](#).

#### 28.4.1.5 BDLC Stop Mode

This power-conserving mode is entered automatically from run mode whenever the CPU executes a STOP instruction or if the CPU executes a WAIT instruction and the WCM bit in the BCR1 is set previously.

In this mode, the BDLC internal clocks are stopped but the physical interface circuitry is placed in a low-power mode and awaits network activity. If network activity is sensed, then a CPU interrupt request will be generated, restarting the BDLC internal clocks. See [28.8.2 Stop Mode](#).

#### 28.4.1.6 Digital Loopback Mode

When a bus fault has been detected, the digital loopback mode is used to determine if the fault condition is caused by failure in the node's internal circuits or elsewhere in the network, including the node's analog physical interface. In this mode, the transmit digital output pin (BDTxD) and the receive digital input pin (BDRxD) of the digital interface are disconnected from the analog physical interface and tied together to allow the digital portion of the BDLC to transmit and receive its own messages without driving the J1850 bus.

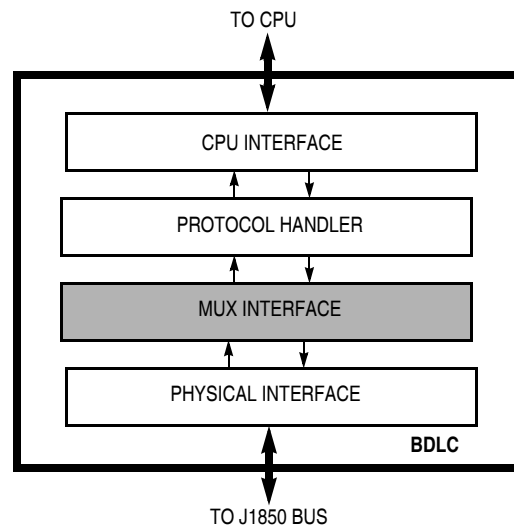
#### 28.4.1.7 Analog Loopback Mode

Analog loopback mode is used to determine if a bus fault has been caused by a failure in the node's off-chip analog transceiver or elsewhere in the network. The BDLC analog loopback mode does not modify the digital transmit or receive functions of the BDLC. It does, however, ensure that once analog loopback mode is exited, the BDLC will wait for an idle bus condition before participation in network communication resumes. If the off-chip analog transceiver has a loopback mode, it usually causes the input to the output drive stage to be looped back into the receiver, allowing the node to receive messages it has transmitted without driving the J1850 bus. In this mode, the output to the J1850 bus typically is high impedance. This allows the

communication path through the analog transceiver to be tested without interfering with network activity. Using the BDLC analog loopback mode in conjunction with the analog transceiver’s loopback mode ensures that, once the off-chip analog transceiver has exited loopback mode, the BCLD will not begin communicating before a known condition exists on the J1850 bus.

## 28.5 BDLC MUX Interface

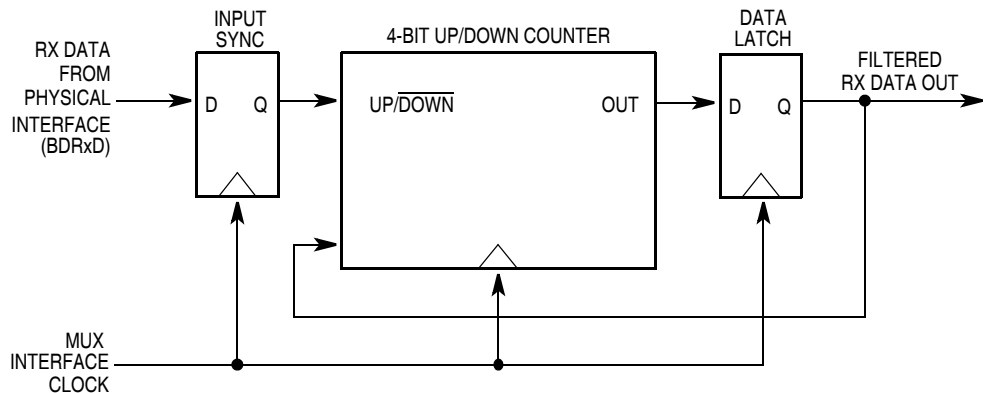
The MUX interface is responsible for bit encoding/decoding and digital noise filtering between the protocol handler and the physical interface.



**Figure 28-3. BDLC Block Diagram**

## 28.5.1 Rx Digital Filter

The receiver section of the BDLC includes a digital low pass filter to remove narrow noise pulses from the incoming message. An outline of the digital filter is shown in [Figure 28-4](#).



**Figure 28-4. BDLC Rx Digital Filter Block Diagram**

### 28.5.1.1 Operation

The clock for the digital filter is provided by the MUX interface clock (see  $f_{\text{BDLC}}$  parameter in [Table 28-4](#)). At each positive edge of the clock signal, the current state of the receiver physical interface (BDRxD) signal is sampled. The BDRxD signal state is used to determine whether the counter should increment or decrement at the next negative edge of the clock signal.

The counter will increment if the input data sample is high but decrement if the input sample is low. Therefore, the counter will thus progress either up toward 15 if, on average, the BDRxD signal remains high or progress down toward 0 if, on average, the BDRxD signal remains low.

When the counter eventually reaches the value 15, the digital filter decides that the condition of the BDRxD signal is at a stable logic level 1 and the data latch is set, causing the filtered Rx data signal to become a logic level 1. Furthermore, the counter is prevented from overflowing and can be decremented only from this state.



Alternatively, should the counter eventually reach the value 0, the digital filter decides that the condition of the BDRxD signal is at a stable logic level 0 and the data latch is reset, causing the filtered Rx data signal to become a logic level 0. Furthermore, the counter is prevented from underflowing and can only be incremented from this state.

The data latch will retain its value until the counter next reaches the opposite end point, signifying a definite transition of the signal.

### 28.5.1.2 Performance

The performance of the digital filter is best described in the time domain rather than the frequency domain.

If the signal on the BDRxD signal transitions, then there will be a delay before that transition appears at the filtered Rx data output signal. This delay will be between 15 and 16 clock periods, depending on where the transition occurs with respect to the sampling points. This filter delay must be taken into account when performing message arbitration.

For example, if the frequency of the MUX interface clock ( $f_{\text{BDLC}}$ ) is 1.0486 MHz, then the period ( $t_{\text{BDLC}}$ ) is 954 ns and the maximum filter delay in the absence of noise will be 15.259  $\mu\text{s}$ .

The effect of random noise on the BDRxD signal depends on the characteristics of the noise itself. Narrow noise pulses on the BDRxD signal will be ignored completely if they are shorter than the filter delay. This provides a degree of low pass filtering.

If noise occurs during a symbol transition, the detection of that transition can be delayed by an amount equal to the length of the noise burst. This is just a reflection of the uncertainty of where the transition is truly occurring within the noise.

Noise pulses that are wider than the filter delay, but narrower than the shortest allowable symbol length, will be detected by the next stage of the BDLC's receiver as an invalid symbol.

Noise pulses that are longer than the shortest allowable symbol length will be detected normally as an invalid symbol or as invalid data when the frame's CRC is checked.

## 28.5.2 J1850 Frame Format

All messages transmitted on the J1850 bus are structured using the format shown in [Figure 28-5](#).

J1850 states that each message has a maximum length of 101 PWM bit times or 12 VPW bytes, excluding SOF, EOD, NB, and EOF, with each byte transmitted most significant bit (MSB) first.

All VPW symbol lengths in the following descriptions are typical values at a 10.4-kbps bit rate.

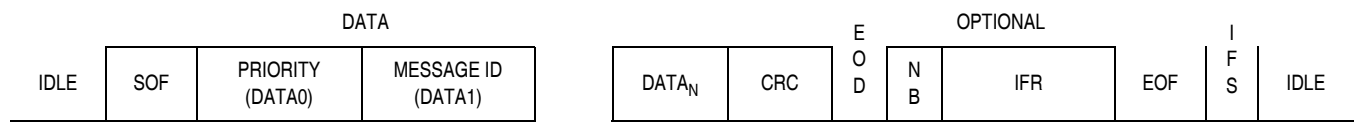
### SOF — Start-of-Frame Symbol

All messages transmitted onto the J1850 bus must begin with a long-active 200  $\mu$ s period SOF symbol. This indicates the start of a new message transmission. The SOF symbol is not used in the CRC calculation.

### Data — In-Message Data Bytes

The data bytes contained in the message include the message priority/type, message ID byte (typically the physical address of the responder), and any actual data being transmitted to the receiving node. The message format used by the BDLC is similar to the 3-byte consolidated header message format outlined by the SAE J1850 document. See *SAE J1850 Class B Data Communications Network Interface* for more information about 1- and 3-byte headers.

Messages transmitted by the BDLC onto the J1850 bus must contain at least one data byte, and, therefore, can be as short as one data byte and one CRC byte. Each data byte in the message is eight bits in length and is transmitted MSB to LSB (least significant bit).



**Figure 28-5. J1850 Bus Message Format (VPW)**

### CRC — Cyclical Redundancy Check Byte

This byte is used by the receiver(s) of each message to determine if any errors have occurred during the transmission of the message. The BDLC calculates the CRC byte and appends it onto any messages transmitted onto the J1850 bus. It also performs CRC detection on any messages it receives from the J1850 bus.

CRC generation uses the divisor polynomial  $X^8 + X^4 + X^3 + X^2 + 1$ . The remainder polynomial initially is set to all ones. Each byte in the message after the start-of-frame (SOF) symbol is processed serially through the CRC generation circuitry. The one's complement of the remainder then becomes the 8-bit CRC byte, which is appended to the message after the data bytes, in MSB-to-LSB order.

When receiving a message, the BDLC uses the same divisor polynomial. All data bytes, excluding the SOF and end of data symbols (EOD) but including the CRC byte, are used to check the CRC. If the message is error free, the remainder polynomial will equal  $X^7 + X^6 + X^2 = \$C4$ , regardless of the data contained in the message. If the calculated CRC does not equal  $\$C4$ , the BDLC will recognize this as a CRC error and set the CRC error flag in the BSVR.

### EOD — End-of-Data Symbol

The EOD symbol is a long 200- $\mu$ s passive period on the J1850 bus used to signify to any recipients of a message that the transmission by the originator has completed. No flag is set upon reception of the EOD symbol.

### IFR — In-Frame Response Bytes

The IFR section of the J1850 message format is optional. Users desiring further definition of in-frame response should review the *SAE J1850 Class B Data Communications Network Interface* specification.

### EOF — End-of-Frame Symbol

This symbol is a long 280- $\mu$ s passive period on the J1850 bus and is longer than an end-of-data (EOD) symbol, which signifies the end of a message. Since an EOF symbol is longer than a 200- $\mu$ s EOD

symbol, if no response is transmitted after an EOD symbol, it becomes an EOF, and the message is assumed to be completed. The EOF flag is set upon receiving the EOF symbol.

#### IFS — Inter-Frame Separation Symbol

The IFS symbol is a 20- $\mu$ s passive period on the J1850 bus which allows proper synchronization between nodes during continuous message transmission. The IFS symbol is transmitted by a node after the completion of the end-of-frame (EOF) period and, therefore is seen as a 300- $\mu$ s passive period.

When the last byte of a message has been transmitted onto the J1850 bus and the EOF symbol time has expired, all nodes then must wait for the IFS symbol time to expire before transmitting a start-of-frame (SOF) symbol, marking the beginning of another message.

However, if the BDLC is waiting for the IFS period to expire before beginning a transmission and a rising edge is detected before the IFS time has expired, it will synchronize internally to that edge.

A rising edge may occur during the IFS period because of varying clock tolerances and loading of the J1850 bus, causing different nodes to observe the completion of the IFS period at different times. To allow for individual clock tolerances, receivers must synchronize to any SOF occurring during an IFS period.

#### BREAK — Break

The BDLC cannot transmit a BREAK symbol.

If the BDLC is transmitting at the time a BREAK is detected, it treats the BREAK as if a transmission error had occurred and halts transmission.

If the BDLC detects a BREAK symbol while receiving a message, it treats the BREAK as a reception error and sets the invalid symbol flag in the BSVR, also ignoring the frame it was receiving. If while receiving a message in 4X mode, the BDLC detects a BREAK symbol, it treats the BREAK as a reception error, sets the invalid symbol flag, and exits 4X mode (for example, the RX4XE bit in BCR2 is cleared automatically). If bus control is required after the BREAK symbol is received and the IFS time has elapsed, the programmer must resend the transmission byte using highest priority.

**NOTE:** *The J1850 protocol BREAK symbol is not related to the HC08 Break Module (See [Section 11. Break Module \(BRK\)](#).)*

#### IDLE — Idle Bus

An idle condition exists on the bus during any passive period after expiration of the IFS period (for example, > 300  $\mu$ s). Any node sensing an idle bus condition can begin transmission immediately.

### 28.5.3 J1850 VPW Symbols

Huntsinger’s variable pulse width modulation (VPW) is an encoding technique in which each bit is defined by the time between successive transitions and by the level of the bus between transitions, (for instance, active or passive). Active and passive bits are used alternately. This encoding technique is used to reduce the number of bus transitions for a given bit rate.

Each logic 1 or logic 0 contains a single transition and can be at either the active or passive level and one of two lengths, either 64  $\mu$ s or 128  $\mu$ s ( $t_{\text{NOM}}$  at 10.4 kbps baud rate), depending upon the encoding of the previous bit. The start-of-frame (SOF), end-of-data (EOD), end-of-frame (EOF), and inter-frame separation (IFS) symbols always will be encoded at an assigned level and length. See [Figure 28-6](#).

Each message will begin with an SOF symbol, an active symbol, and, therefore, each data byte (including the CRC byte) will begin with a passive bit, regardless of whether it is a logic 1 or a logic 0.

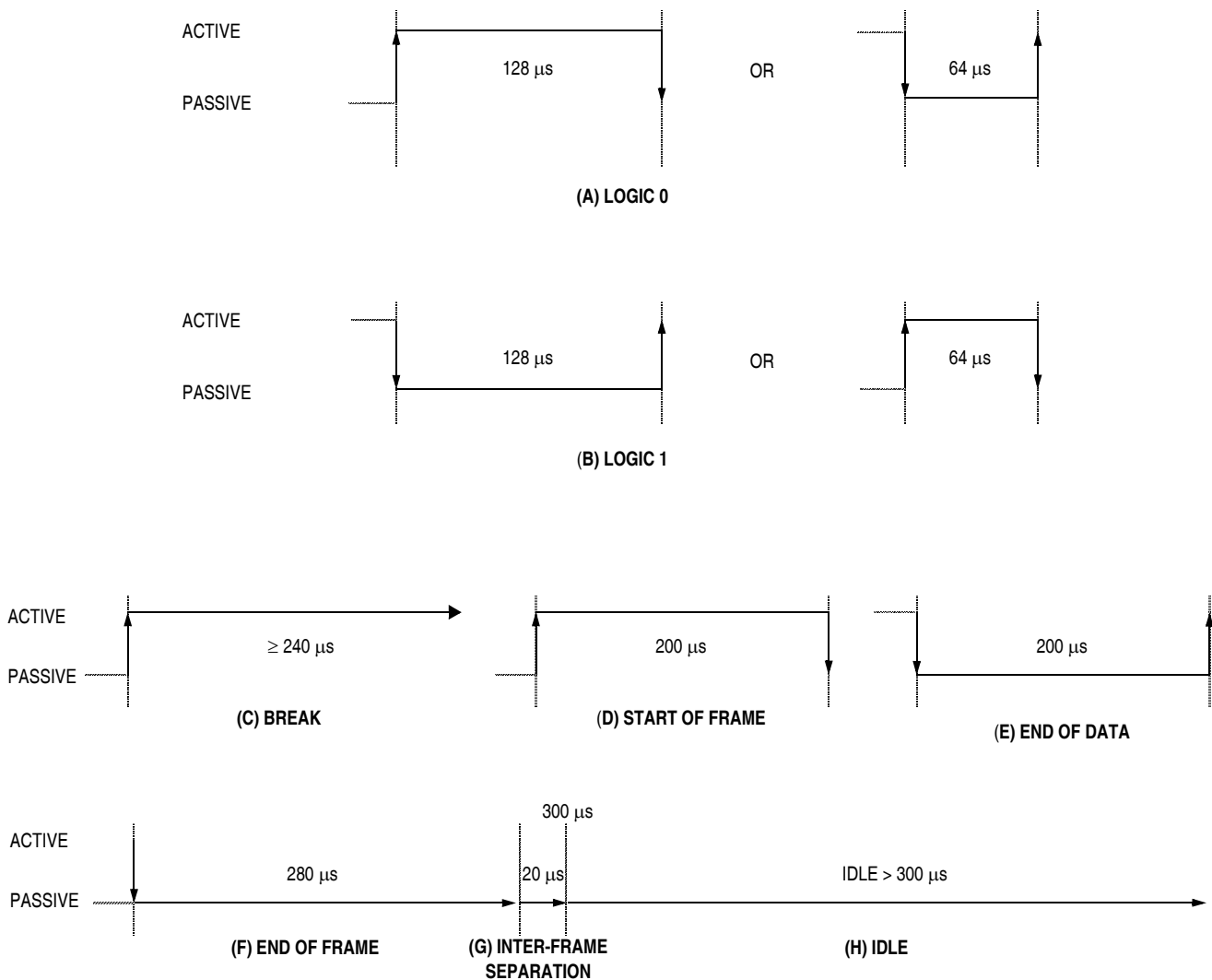
All VPW bit lengths stated in the following descriptions are typical values at a 10.4-kbps bit rate. EOF, EOD, IFS, and IDLE, however, are not driven J1850 bus states. They are passive bus periods observed by each node’s CPU.

## Logic 0

A logic 0 is defined as either:

- An active-to-passive transition followed by a passive period 64  $\mu\text{s}$  in length, or
- A passive-to-active transition followed by an active period 128  $\mu\text{s}$  in length

See [Figure 28-6\(a\)](#).



**Figure 28-6. J1850 VPW Symbols with Nominal Symbol Times**

### Logic 1

A logic 1 is defined as either:

- An active-to-passive transition followed by a passive period 128  $\mu\text{s}$  in length, or
- A passive-to-active transition followed by an active period 64  $\mu\text{s}$  in length

See [Figure 28-6\(b\)](#).

### Normalization Bit (NB)

The NB symbol has the same property as a logic 1 or a logic 0. It is only used in IFR message responses.

### Break Signal (BREAK)

The BREAK signal is defined as a passive-to-active transition followed by an active period of at least 240  $\mu\text{s}$  (see [Figure 28-6\(c\)](#)).

### Start-of-Frame Symbol (SOF)

The SOF symbol is defined as passive-to-active transition followed by an active period 200  $\mu\text{s}$  in length (see [Figure 28-6\(d\)](#)). This allows the data bytes which follow the SOF symbol to begin with a passive bit, regardless of whether it is a logic 1 or a logic 0.

### End-of-Data Symbol (EOD)

The EOD symbol is defined as an active-to-passive transition followed by a passive period 200  $\mu\text{s}$  in length (see [Figure 28-6\(e\)](#)).

### End-of-Frame Symbol (EOF)

The EOF symbol is defined as an active-to-passive transition followed by a passive period 280  $\mu\text{s}$  in length (see [Figure 28-6\(f\)](#)). If no IFR byte is transmitted after an EOD symbol is transmitted, after another 80  $\mu\text{s}$  the EOD becomes an EOF, indicating completion of the message.

### Inter-Frame Separation Symbol (IFS)

The IFS symbol is defined as a passive period 300  $\mu\text{s}$  in length. The 20- $\mu\text{s}$  IFS symbol contains no transition, since when it is used it always appends to a 280- $\mu\text{s}$  EOF symbol (see [Figure 28-6\(g\)](#)).

### Idle

An idle is defined as a passive period greater than 300  $\mu$ s in length.

#### 28.5.4 J1850 VPW Valid/Invalid Bits and Symbols

The timing tolerances for **receiving** data bits and symbols from the J1850 bus have been defined to allow for variations in oscillator frequencies. In many cases, the maximum time allowed to define a data bit or symbol is equal to the minimum time allowed to define another data bit or symbol.

Since the minimum resolution of the BDLC for determining what symbol is being received is equal to a single period of the MUX interface clock ( $t_{BDLC}$ ), an apparent separation in these maximum time/minimum time concurrences equals one cycle of  $t_{BDLC}$ .

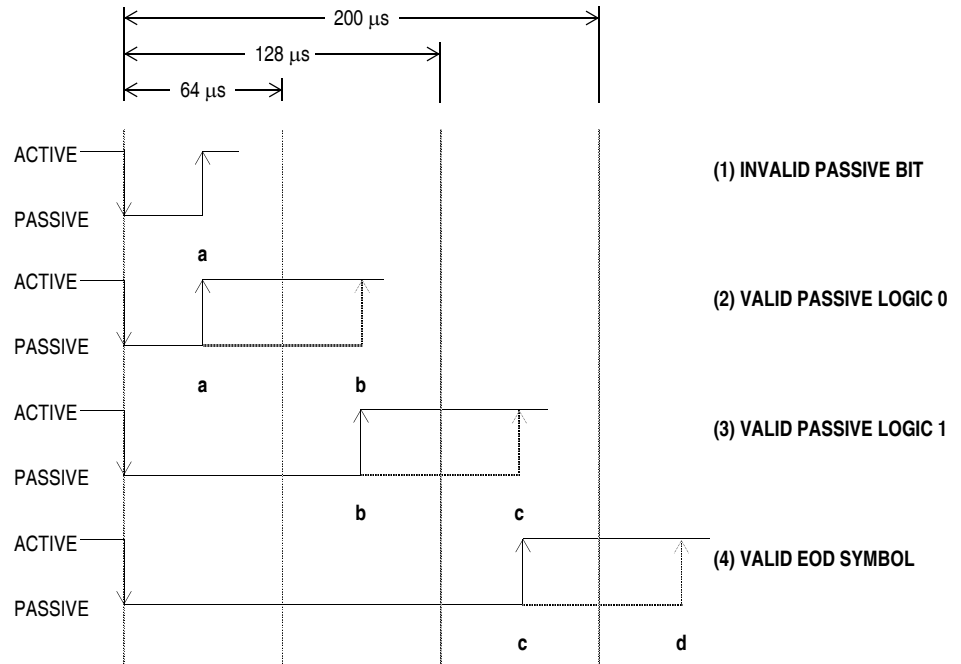
This one clock resolution allows the BDLC to differentiate properly between the different bits and symbols. This is done without reducing the valid window for receiving bits and symbols from transmitters onto the J1850 bus, which has varying oscillator frequencies.

In Huntsinger's variable pulse width (VPW) modulation bit encoding, the tolerances for both the passive and active data bits received and the symbols received are defined with no gaps between definitions. For example, the maximum length of a passive logic 0 is equal to the minimum length of a passive logic 1, and the maximum length of an active logic 0 is equal to the minimum length of a valid SOF symbol.

#### Invalid Passive Bit

See [Figure 28-7\(1\)](#). If the passive-to-active received transition beginning the next data bit or symbol occurs between the active-to-passive transition beginning the current data bit (or symbol) and **a**, the current bit would be invalid.





**Figure 28-7. J1850 VPW Received Passive Symbol Times**

### Valid Passive Logic 0

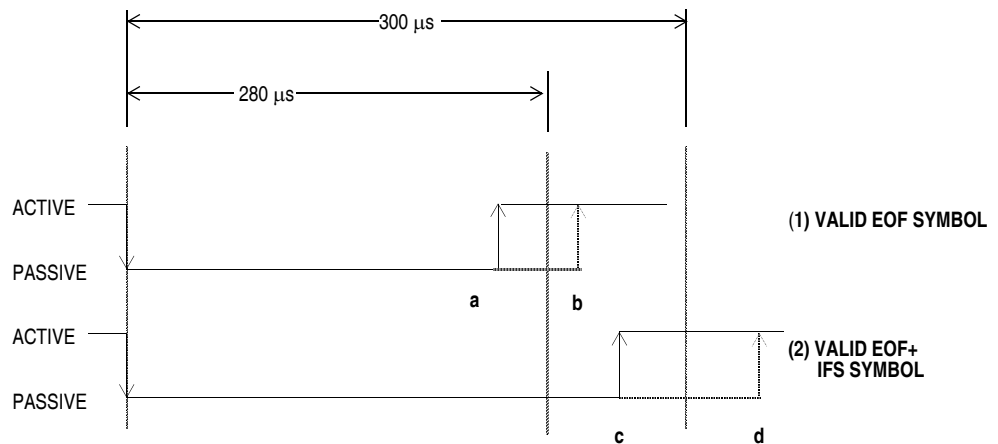
See [Figure 28-7\(2\)](#). If the passive-to-active received transition beginning the next data bit (or symbol) occurs between **a** and **b**, the current bit would be considered a logic 0.

### Valid Passive Logic 1

See [Figure 28-7\(3\)](#). If the passive-to-active received transition beginning the next data bit (or symbol) occurs between **b** and **c**, the current bit would be considered a logic 1.

### Valid EOD Symbol

See [Figure 28-7\(4\)](#). If the passive-to-active received transition beginning the next data bit (or symbol) occurs between **c** and **d**, the current symbol would be considered a valid end-of-data symbol (EOD).



**Figure 28-8. J1850 VPW Received Passive EOF and IFS Symbol Times**

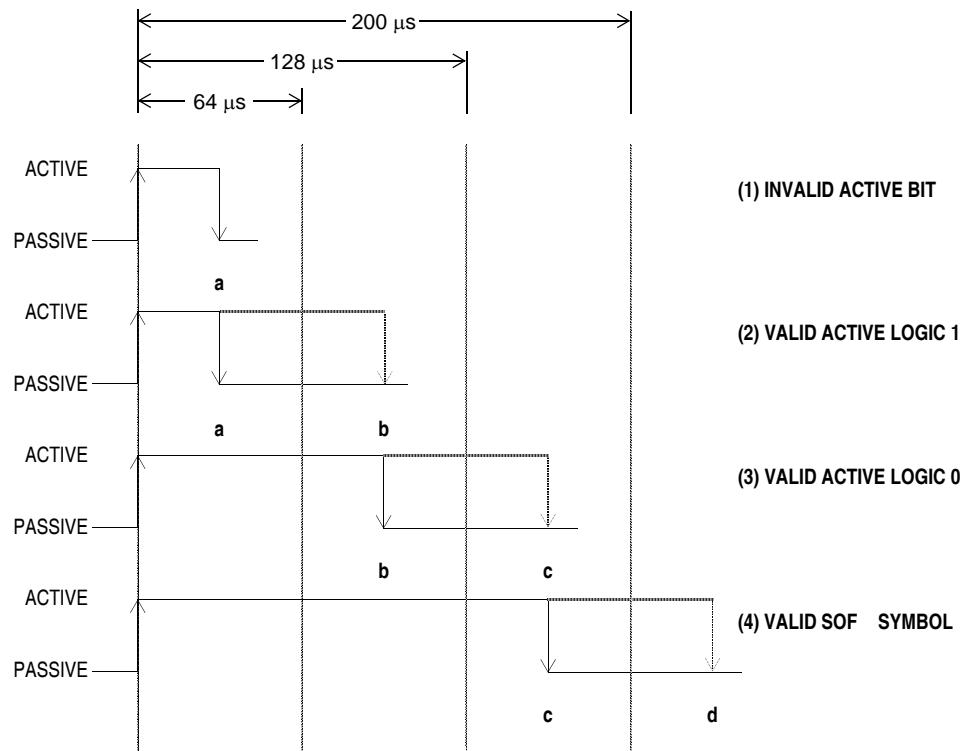
### Valid EOF and IFS Symbols

In [Figure 28-8\(1\)](#), if the passive-to-active received transition beginning the SOF symbol of the next message occurs between **a** and **b**, the current symbol will be considered a valid end-of-frame (EOF) symbol.

See [Figure 28-8\(2\)](#). If the passive-to-active received transition beginning the SOF symbol of the next message occurs between **c** and **d**, the current symbol will be considered a valid EOF symbol followed by a valid inter-frame separation symbol (IFS). All nodes must wait until a valid IFS symbol time has expired before beginning transmission. However, due to variations in clock frequencies and bus loading, some nodes may recognize a valid IFS symbol before others and immediately begin transmitting. Therefore, any time a node waiting to transmit detects a passive-to-active transition once a valid EOF has been detected, it should immediately begin transmission, initiating the arbitration process.

### Idle Bus

In [Figure 28-8\(2\)](#), if the passive-to-active received transition beginning the start-of-frame (SOF) symbol of the next message does not occur before **d**, the bus is considered to be idle, and any node wishing to transmit a message may do so immediately.



**Figure 28-9. J1850 VPW Received Active Symbol Times**

### Invalid Active Bit

In [Figure 28-9\(1\)](#), if the active-to-passive received transition beginning the next data bit (or symbol) occurs between the passive-to-active transition beginning the current data bit (or symbol) and **a**, the current bit would be invalid.

### Valid Active Logic 1

In [Figure 28-9\(2\)](#), if the active-to-passive received transition beginning the next data bit (or symbol) occurs between **a** and **b**, the current bit would be considered a logic 1.

### Valid Active Logic 0

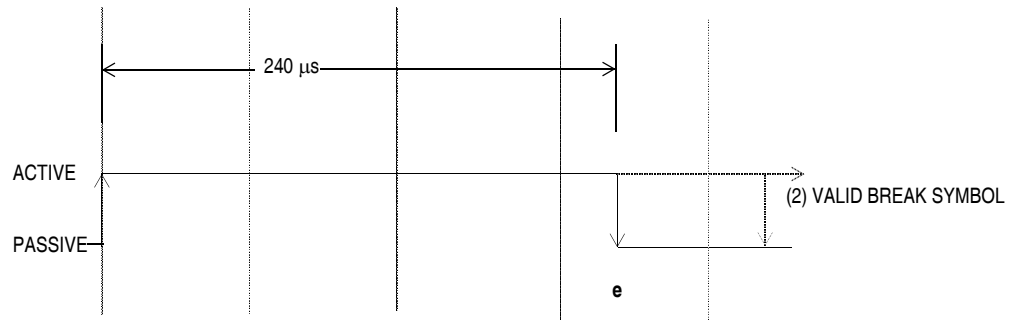
In [Figure 28-9\(3\)](#), if the active-to-passive received transition beginning the next data bit (or symbol) occurs between **b** and **c**, the current bit would be considered a logic 0.

## Valid SOF Symbol

In [Figure 28-9\(4\)](#), if the active-to-passive received transition beginning the next data bit (or symbol) occurs between **c** and **d**, the current symbol would be considered a valid SOF symbol.

## Valid BREAK Symbol

In [Figure 28-10](#), if the next active-to-passive received transition does not occur until after **e**, the current symbol will be considered a valid BREAK symbol. A BREAK symbol should be followed by a start-of-frame (SOF) symbol beginning the next message to be transmitted onto the J1850 bus. See [28.5.2 J1850 Frame Format](#) for BDLC response to BREAK symbols.



**Figure 28-10. J1850 VPW Received BREAK Symbol Times**

## 28.5.5 Message Arbitration

Message arbitration on the J1850 bus is accomplished in a non-destructive manner, allowing the message with the highest priority to be transmitted, while any transmitters which lose arbitration simply stop transmitting and wait for an idle bus to begin transmitting again.

If the BDLC wants to transmit onto the J1850 bus, but detects that another message is in progress, it waits until the bus is idle. However, if multiple nodes begin to transmit in the same synchronization window, message arbitration will occur beginning with the first bit after the SOF symbol and continue with each bit thereafter. If a write to the BDR (for instance, to initiate transmission) occurred on or before  $104 \cdot t_{BDLC}$  from the received rising edge, then the BDLC will transmit

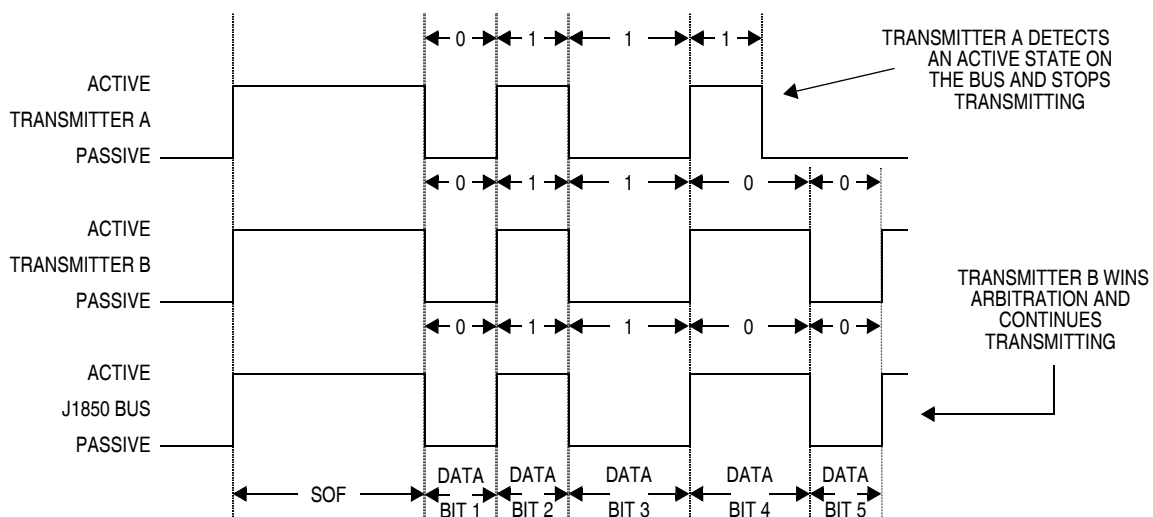
and arbitrate for the bus. If a CPU write to the BDR occurred after  $104 \cdot t_{BDLC}$  from the detection of the rising edge, then the BDLC will not transmit, but will wait for the next IFS period to expire before attempting to transmit the byte.

The variable pulse width modulation (VPW) symbols and J1850 bus electrical characteristics are chosen carefully so that a logic 0 (active or passive type) will always dominate over a logic 1 (active or passive type) simultaneously transmitted. Hence, logic 0s are said to be dominant and logic 1s are said to be recessive.

Whenever a node detects a dominant bit on BDRxD when it transmitted a recessive bit, it loses arbitration and immediately stops transmitting. This is known as bitwise arbitration.

Since a logic 0 dominates a logic 1, the message with the lowest value will have the highest priority and will always win arbitration. For instance, a message with priority 000 will win arbitration over a message with priority 011.

This method of arbitration will work no matter how many bits of priority encoding are contained in the message.



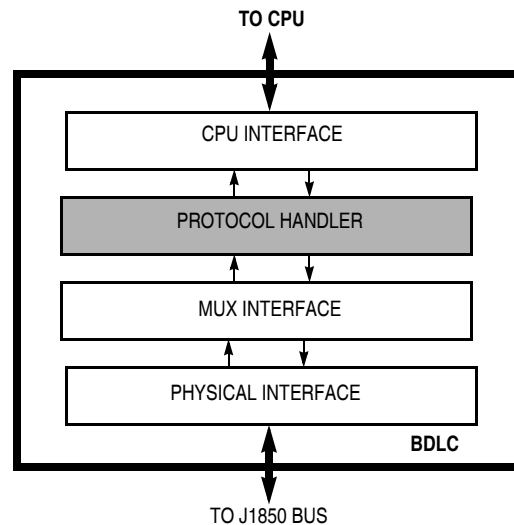
**Figure 28-11. J1850 VPW Bitwise Arbitrations**

During arbitration, or even throughout the transmitting message, when an opposite bit is detected, transmission is stopped immediately unless it occurs on the 8th bit of a byte. In this case, the BDLC automatically will append up to two extra logic 1 bits and then stop transmitting. These two extra bits will be arbitrated normally and thus will not interfere with another message. The second logic 1 bit will not be sent if the first loses arbitration. If the BDLC has lost arbitration to another valid message, then the two extra logic 1s will not corrupt the current message. However, if the BDLC has lost arbitration due to noise on the bus, then the two extra logic 1s will ensure that the current message will be detected and ignored as a noise-corrupted message.

## 28.6 BDLC Protocol Handler

The protocol handler is responsible for framing, arbitration, CRC generation/checking, and error detection. The protocol handler conforms to *SAE J1850 Class B Data Communications Network Interface*.

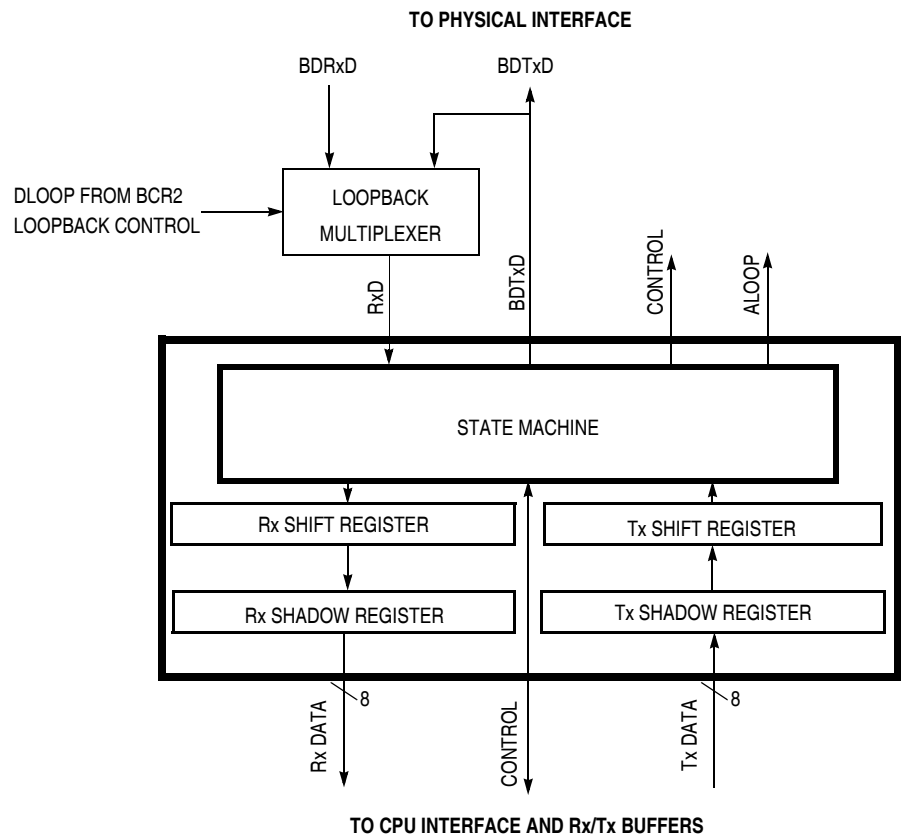
**NOTE:** *Freescale assumes that the reader is familiar with the J1850 specification before reading this protocol handler description.*



**Figure 28-12. BDLC Block Diagram**

### 28.6.1 Protocol Architecture

The protocol handler contains the state machine, Rx shadow register, Tx shadow register, Rx shift register, Tx shift register, and loopback multiplexer as shown in **Figure 28-13**.



**Figure 28-13. BDLC Protocol Handler Outline**

### 28.6.2 Rx and Tx Shift Registers

The Rx shift register gathers received serial data bits from the J1850 bus and makes them available in parallel form to the Rx shadow register. The Tx shift register takes data, in parallel form, from the Tx shadow register and presents it serially to the state machine so that it can be transmitted onto the J1850 bus.

### 28.6.3 Rx and Tx Shadow Registers

Immediately after the Rx shift register has completed shifting in a byte of data, this data is transferred to the Rx shadow register and RDRF or RXIFR is set (see [28.7.4 BDLC State Vector Register](#)). An interrupt is generated if the interrupt enable bit (IE) in BCR1 is set. After the transfer takes place, this new data byte in the Rx shadow register is available to the CPU interface, and the Rx shift register is ready to shift in the next byte of data. Data in the Rx shadow register must be retrieved by the CPU before it is overwritten by new data from the Rx shift register.

Once the Tx shift register has completed its shifting operation for the current byte, the data byte in the Tx shadow register is loaded into the Tx shift register. After this transfer takes place, the Tx shadow register is ready to accept new data from the CPU when the TDRE flag in the BSVR is set.

### 28.6.4 Digital Loopback Multiplexer

The digital loopback multiplexer connects RxD to either BDTxD or BDRxD, depending on the state of the DLOOP bit in the BCR2 (See [28.7.3 BDLC Control Register 2](#)).

### 28.6.5 State Machine

All functions associated with performing the protocol are executed or controlled by the state machine. The state machine is responsible for framing, collision detection, arbitration, CRC generation/checking, and error detection. The following sections describe the BDLC's actions in a variety of situations.

#### 28.6.5.1 4X Mode

The BDLC can exist on the same J1850 bus as modules which use a special 4X (41.6 kbps) mode of J1850 variable pulse width modulation (VPW) operation. The BDLC cannot transmit in 4X mode, but it can receive messages in 4X mode, if the RX4X bit is set in BCR2. If the



RX4X bit is not set in the BCR2, any 4X message on the J1850 bus is treated as noise by the BDLC and is ignored.

#### 28.6.5.2 Receiving a Message in Block Mode

Although not a part of the SAE J1850 protocol, the BDLC does allow for a special block mode of operation of the receiver. As far as the BDLC is concerned, a block mode message is simply a long J1850 frame that contains an indefinite number of data bytes. All other features of the frame remain the same, including the SOF, CRC, and EOD symbols.

Another node wishing to send a block mode transmission must first inform all other nodes on the network that this is about to happen. This is usually accomplished by sending a special predefined message.

#### 28.6.5.3 Transmitting a Message in Block Mode

A block mode message is transmitted inherently by simply loading the bytes one by one into the BDR until the message is complete. The programmer should wait until the TDRE flag (see [28.7.4 BDLC State Vector Register](#)) is set prior to writing a new byte of data into the BDR. The BDLC does not contain any predefined maximum J1850 message length requirement.

#### 28.6.5.4 J1850 Bus Errors

The BDLC detects several types of transmit and receive errors which can occur during the transmission of a message onto the J1850 bus.

##### **Transmission Error**

If the message transmitted by the BDLC contains invalid bits or framing symbols on non-byte boundaries, this constitutes a transmission error. When a transmission error is detected, the BDLC immediately will cease transmitting. The error condition is reflected in the BSVR (see [Table 28-6](#)). If the interrupt enable bit (IE in BCR1) is set, a CPU interrupt request from the BDLC is generated.

### CRC Error

A cyclical redundancy check (CRC) error is detected when the data bytes and CRC byte of a received message are processed and the CRC calculation result is not equal. The CRC code will detect any single and 2-bit errors, as well as all 8-bit burst errors and almost all other types of errors. The CRC error flag (in BSVR) is set when a CRC error is detected. (See [28.7.4 BDLC State Vector Register](#).)

### Symbol Error

A symbol error is detected when an abnormal (invalid) symbol is detected in a message being received from the J1850 bus. The invalid symbol is set when a symbol error is detected. (See [28.7.4 BDLC State Vector Register](#).)

### Framing Error

A framing error is detected if an EOD or EOF symbol is detected on a non-byte boundary from the J1850 bus. A framing error also is detected if the BDLC is transmitting the EOD and instead receives an active symbol. The symbol invalid, or the out-of-range flag, is set when a framing error is detected. (See [28.7.4 BDLC State Vector Register](#).)

### Bus Fault

If a bus fault occurs, the response of the BDLC will depend upon the type of bus fault.

If the bus is shorted to battery, the BDLC will wait for the bus to fall to a passive state before it will attempt to transmit a message. As long as the short remains, the BDLC will never attempt to transmit a message onto the J1850 bus.

If the bus is shorted to ground, the BDLC will see an idle bus, begin to transmit the message, and then detect a transmission error (in BSVR), since the short to ground would not allow the bus to be driven to the active (dominant) SOF state. The BDLC will abort that transmission and wait for the next CPU command to transmit.

In any case, if the bus fault is temporary, as soon as the fault is cleared, the BDLC will resume normal operation. If the bus fault is permanent, it may result in permanent loss of communication on the J1850 bus. (See [28.7.4 BDLC State Vector Register](#).)

### BREAK — Break

If a BREAK symbol is received while the BDLC is transmitting or receiving, an invalid symbol (in BSVR) interrupt will be generated. Reading the BSVR (see [28.7.4 BDLC State Vector Register](#)) will clear this interrupt condition. The BDLC will wait for the bus to idle, then wait for a start-of-frame (SOF) symbol.

The BDLC cannot transmit a BREAK symbol. It only can receive a BREAK symbol from the J1850 bus.

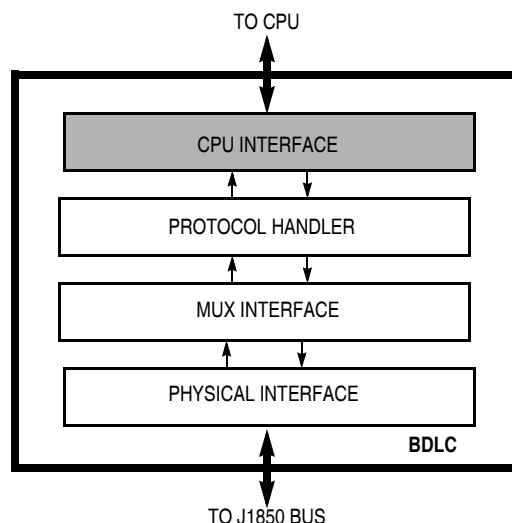
#### 28.6.5.5 Summary

**Table 28-2. BDLC J1850 Bus Error Summary**

Error Condition	BDLC Function
Transmission Error	For invalid bits or framing symbols on non-byte boundaries, invalid symbol interrupt will be generated. BDLC stops transmission.
Cyclical Redundancy Check (CRC) Error	CRC error interrupt will be generated. The BDLC will wait for EOF.
Invalid Symbol: BDLC transmits, but Receives Invalid Bits (Noise)	The BDLC will abort transmission immediately. Invalid symbol interrupt will be generated.
Framing Error	Invalid symbol interrupt will be generated. The BDLC will wait for end of frame (EOF).
Bus Short to $V_{DD}$	The BDLC will not transmit until the bus is idle. Invalid symbol interrupt will be generated. EOF interrupt also must be seen before another transmission attempt. Depending on length of the short, LOA flag also may be set.
Bus Short to GND	Thermal overload will shut down physical interface. Fault condition is seen as invalid symbol flag. EOF interrupt must also be seen before another transmission attempt.
BDLC Receives BREAK Symbol	Invalid symbol interrupt will be generated. The BDLC will wait for the next valid SOF.

## 28.7 BDLC CPU Interface

The CPU interface provides the interface between the CPU and the BDLC and consists of five user registers.



**Figure 28-14. BDLC Block Diagram**

### 28.7.1 BDLC Analog and Roundtrip Delay

This register programs the BDLC to compensate for various delays of different external transceivers. The default delay value is 16  $\mu$ s. Timing adjustments from 9  $\mu$ s to 24  $\mu$ s in steps of 1  $\mu$ s are available. The BARD register can be written only once after each reset, after which they become read-only bits. The register may be read at any time.

Address: \$003B

	Bit 7	6	5	4	3	2	1	Bit 0
Read:	ATE	RXPOL	0	0	BO3	BO2	BO1	BO0
Write:								
Reset:	1	1	0	0	0	1	1	1

= Unimplemented

**Figure 28-15. BDLC Analog and Roundtrip Delay Register (BARD)**

ATE — Analog Transceiver Enable Bit

The analog transceiver enable (ATE) bit is used to select either the on-board or an off-chip analog transceiver.

- 1 = Select on-board analog transceiver
- 0 = Select off-chip analog transceiver

**NOTE:** *This device does not contain an on-board transceiver. This bit should be programmed to a logic 0 for proper operation.*

#### RXPOL — Receive Pin Polarity Bit

The receive pin polarity (RXPOL) bit is used to select the polarity of an incoming signal on the receive pin. Some external analog transceivers invert the receive signal from the J1850 bus before feeding it back to the digital receive pin.

- 1 = Select normal/true polarity; true non-inverted signal from the J1850 bus; for example, the external transceiver does not invert the receive signal
- 0 = Select inverted polarity, where an external transceiver inverts the receive signal from the J1850 bus

#### BO3–BO0 — BARD Offset Bits

**Table 28-3** shows the expected transceiver delay with respect to BARD offset values.

**Table 28-3. BDLC Transceiver Delay**

BARD Offset Bits BO[3:0]	Corresponding Expected Transceiver's Delays ( $\mu$ s)
0000	9
0001	10
0010	11
0011	12
0100	13
0101	14
0110	15
0111	16
1000	17
1001	18
1010	19
1011	20
1100	21
1101	22
1110	23
1111	24

### 28.7.2 BDLC Control Register 1

This register is used to configure and control the BDLC.

Address: \$003C

	Bit 7	6	5	4	3	2	1	Bit 0
Read:	IMSG	CLKS	R1	R0	0	0	IE	WCM
Write:					R	R		
Reset:	1	1	1	0	0	0	0	0

R = Reserved

**Figure 28-16. BDLC Control Register 1 (BCR1)**

**IMSG — Ignore Message Bit**

This bit is used to disable the receiver until a new start-of-frame (SOF) is detected.

1 = Disable receiver. When set, all BDLC interrupt requests will be masked (except \$20 in BSVR) and the status bits will be held in their reset state. If this bit is set while the BDLC is receiving a message, the rest of the incoming message will be ignored.

0 = Enable receiver. This bit is cleared automatically by the reception of an SOF symbol or a BREAK symbol. It will then generate interrupt requests and will allow changes of the status register to occur. However, these interrupts may still be masked by the interrupt enable (IE) bit.

**CLKS — Clock Bit**

For J1850 bus communications to take place, the nominal BDLC operating frequency ( $f_{\text{BDLC}}$ ) must always be 1.048576 MHz or 1 MHz. The CLKS register bit allows the user to select the frequency (1.048576 MHz or 1 MHz) used to automatically adjust symbol timing.

1 = Binary frequency (1.048576 MHz) selected for  $f_{\text{BDLC}}$

0 = Integer frequency (1 MHz) selected for  $f_{\text{BDLC}}$

**R1 and R0 — Rate Select Bits**

These bits determine the amount by which the frequency of the MCU CGMXCLK signal is divided to form the MUX interface clock ( $f_{\text{BDLC}}$ ) which defines the basic timing resolution of the MUX interface. They may be written only once after reset, after which they become read-only bits.

The nominal frequency of  $f_{\text{BDLC}}$  must always be 1.048576 MHz or 1.0 MHz for J1850 bus communications to take place. Hence, the value programmed into these bits is dependent on the chosen MCU system clock frequency per [Table 28-4](#).



**Table 28-4. BDLC Rate Selection**

$f_{XCLK}$ Frequency	R1	R0	Division	$f_{BDLC}$
1.049 MHz	0	0	1	1.049 MHz
2.097 MHz	0	1	2	1.049 MHz
4.194 MHz	1	0	4	1.049 MHz
8.389 MHz	1	1	8	1.049 MHz
1.000 MHz	0	0	1	1.00 MHz
2.000 MHz	0	1	2	1.00 MHz
4.000 MHz	1	0	4	1.00 MHz
8.000 MHz	1	1	8	1.00 MHz

#### IE— Interrupt Enable Bit

This bit determines whether the BDLC will generate CPU interrupt requests in run mode. It does not affect CPU interrupt requests when exiting the BDLC stop or BDLC wait modes. Interrupt requests will be maintained until all of the interrupt request sources are cleared by performing the specified actions upon the BDLC's registers. Interrupts that were pending at the time that this bit is cleared may be lost.

1 = Enable interrupt requests from BDLC

0 = Disable interrupt requests from BDLC

If the programmer does not wish to use the interrupt capability of the BDLC, the BDLC state vector register (BSVR) can be polled periodically by the programmer to determine BDLC states. See [28.7.4 BDLC State Vector Register](#) for a description of the BSVR.

#### WCM — Wait Clock Mode Bit

This bit determines the operation of the BDLC during CPU wait mode. See [28.8.2 Stop Mode](#) and [28.8.1 Wait Mode](#) for more details on its use.

1 = Stop BDLC internal clocks during CPU wait mode

0 = Run BDLC internal clocks during CPU wait mode

## 28.7.3 BDLC Control Register 2

This register controls transmitter operations of the BDLC. It is recommended that BSET and BCLR instructions be used to manipulate data in this register to ensure that the register’s content does not change inadvertently.

Address: \$003D

	Bit 7	6	5	4	3	2	1	Bit 0
Read:	ALOOP	DLOOP	RX4XE	NBFS	TEOD	TSIFR	TMIFR1	TMIFR0
Write:								
Reset:	1	1	0	0	0	0	0	0

**Figure 28-17. BDLC Control Register 2 (BCR2)**

### ALOOP — Analog Loopback Mode Bit

This bit determines whether the J1850 bus will be driven by the analog physical interface’s final drive stage. The programmer can use this bit to reset the BDLC state machine to a known state after the off-chip analog transceiver is placed in loopback mode. When the user clears ALOOP, to indicate that the off-chip analog transceiver is no longer in loopback mode, the BDLC waits for an EOF symbol before attempting to transmit. Most transceivers have the ALOOP feature available.

- 1 = Input to the analog physical interface’s final drive stage is looped back to the BDLC receiver. The J1850 bus is not driven.
- 0 = The J1850 bus will be driven by the BDLC. After the bit is cleared, the BDLC requires the bus to be idle for a minimum of end-of-frame symbol time ( $t_{TRV4}$ ) before message reception or a minimum of inter-frame symbol time ( $t_{TRV6}$ ) before message transmission. (See [29.15 BDLC Receiver VPW Symbol Timings](#).)

### DLOOP — Digital Loopback Mode Bit

This bit determines the source to which the digital receive input (BDRxD) is connected and can be used to isolate bus fault conditions (see [Figure 28-13](#)). If a fault condition has been detected on the bus, this control bit allows the programmer to connect the digital transmit output to the digital receive input. In this configuration, data sent from the transmit buffer will be reflected back into the receive buffer. If no faults exist in the BDLC, the fault is in the physical interface block or elsewhere on the J1850 bus.

1 = When set, BDRxD is connected to BDTxD. The BDLC is now in digital loopback mode.

0 = When cleared, BDTxD is not connected to BDRxD. The BDLC is taken out of digital loopback mode and can now drive or receive the J1850 bus normally (given ALOOP is not set). After writing DLOOP to 0, the BDLC requires the bus to be idle for a minimum of end-of-frame symbol ( $t_{tv4}$ ) time before allowing a reception of a message. The BDLC requires the bus to be idle for a minimum of inter-frame separator symbol ( $t_{tv6}$ ) time before allowing any message to be transmitted.

### RX4XE — Receive 4X Enable Bit

This bit determines if the BDLC operates at normal transmit and receive speed (10.4 kbps) or receive only at 41.6 kbps. This feature is useful for fast downloading of data into a J1850 node for diagnostic or factory programming of the node.

1 = When set, the BDLC is put in 4X receive-only operation.

0 = When cleared, the BDLC transmits and receives at 10.4 kbps.

Reception of a BREAK symbol automatically clears this bit and sets BDLC state vector register (BSVR) to \$001C.

### NBFS — Normalization Bit Format Select Bit

This bit controls the format of the normalization bit (NB). (See [Figure 28-18](#).) SAE J1850 strongly encourages using an active long (logic 0) for in-frame responses containing cyclical redundancy check (CRC) and an active short (logic 1) for in-frame responses without CRC.

1 = NB that is received or transmitted is a 0 when the response part of an in-frame response (IFR) ends with a CRC byte. NB that is received or transmitted is a 1 when the response part of an in-frame response (IFR) does not end with a CRC byte.

0 = NB that is received or transmitted is a 1 when the response part of an in-frame response (IFR) ends with a CRC byte. NB that is received or transmitted is a 0 when the response part of an in-frame response (IFR) does not end with a CRC byte.

## TEOD — Transmit End-of-Data Bit

This bit is set by the programmer to indicate the end of a message is being sent by the BDLC. It will append an 8-bit CRC after completing transmission of the current byte. This bit also is used to end an in-frame response (IFR). If the transmit shadow register is full when TEOD is set, the CRC byte will be transmitted after the current byte in the Tx shift register and the byte in the Tx shadow register have been transmitted. (See [28.6.3 Rx and Tx Shadow Registers](#) for a description of the transmit shadow register.) Once TEOD is set, the transmit data register empty flag (TDRE) in the BDLC state vector register (BSVR) is cleared to allow lower priority interrupts to occur. (See [28.7.4 BDLC State Vector Register](#).)

1 = Transmit end-of-data (EOD) symbol

0 = The TEOD bit will be cleared automatically at the rising edge of the first CRC bit that is sent or if an error is detected. When TEOD is used to end an IFR transmission, TEOD is cleared when the BDLC receives back a valid EOD symbol or an error condition occurs.

## TSIFR, TMIFR1, and TMIFR0 — Transmit In-Frame Response Control Bits

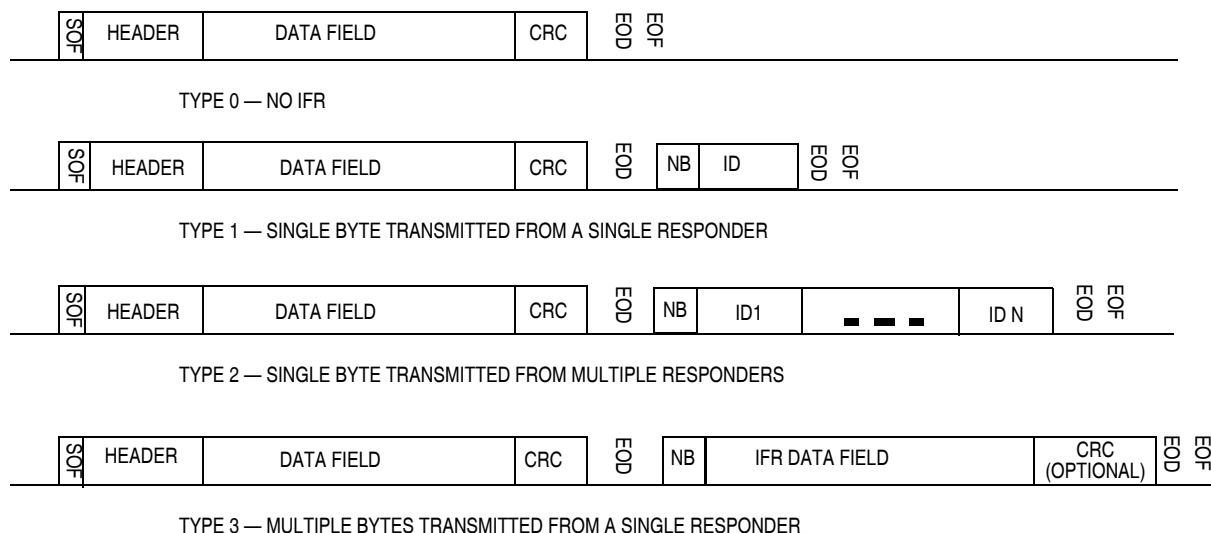
These three bits control the type of in-frame response being sent. The programmer should not set more than one of these control bits to a 1 at any given time. However, if more than one of these three control bits are set to 1, the priority encoding logic will force these register bits to a known value as shown in [Table 28-5](#). For example, if 011 is

written to TSIFR, TMIFR1, and TMIFR0, then internally they will be encoded as 010. However, when these bits are read back, they will read 011.

**Table 28-5. BDLC Transmit In-Frame Response Control Bit Priority Encoding**

Write/Read TSIFR	Write/Read TMIFR1	Write/Read TMIFR0	Actual TSIFR	Actual TMIFR1	Actual TMIFR0
0	0	0	0	0	0
1	X	X	1	0	0
0	1	X	0	1	0
0	0	1	0	0	1

The BDLC supports the in-frame response (IFR) feature of J1850 by setting these bits correctly. The four types of J1850 IFR are shown in the following figure. The purpose of the in-frame response modes is to allow multiple nodes to acknowledge receipt of the data by responding with their personal ID or physical address in a concatenated manner after they have seen the EOD symbol. If transmission arbitration is lost by a node while sending its response, it continues to transmit its ID/address until observing its unique byte in the response stream. For VPW modulation, the first bit of the IFR is always passive; therefore, an active normalization bit must be generated by the responder and sent prior to its ID/address byte. When there are multiple responders on the J1850 bus, only one normalization bit is sent which assists all other transmitting nodes to sync their responses.



NB = Normalization Bit  
 ID = Identifier, usually the physical address of the responder(s)

**Figure 28-18. Types of In-Frame Response (IFR)**

### TSIFR — Transmit Single Byte IFR with No CRC (Type 1 or 2) Bit

The TSIFR bit is used to request the BDLC to transmit the byte in the BDLC data register (BDR) as a single byte IFR with no CRC.

Typically, the byte transmitted is a unique identifier or address of the transmitting (responding) node. See [Figure 28-18](#).

- 1 = If this bit is set prior to a valid EOD being received with no CRC error, once the EOD symbol has been received the BDLC will attempt to transmit the appropriate normalization bit followed by the byte in the BDR.
- 0 = The TSIFR bit will be cleared automatically, once the BDLC has successfully transmitted the byte in the BDR onto the bus, or TEOD is set, or an error is detected on the bus.

If the programmer attempts to set the TSIFR bit immediately after the EOD symbol has been received from the bus, the TSIFR bit will remain in the reset state and no attempt will be made to transmit the IFR byte.

If a loss of arbitration occurs when the BDLC attempts to transmit and after the IFR byte winning arbitration completes transmission, the BDLC

will again attempt to transmit the BDR (with no normalization bit). The BDLC will continue transmission attempts until an error is detected on the bus, or TEOD is set, or the BDLC transmission is successful.

If loss of arbitration occurs in the last two bits of the IFR byte, two additional 1 bits **will not** be sent out because the BDLC will attempt to retransmit the byte in the transmit shift register after the IRF byte winning arbitration completes transmission.

#### TMIFR1 — Transmit Multiple Byte IFR with CRC (Type 3) Bit

The TMIFR1 bit requests the BDLC to transmit the byte in the BDLC data register (BDR) as the first byte of a multiple byte IFR with CRC or as a single byte IFR with CRC. Response IFR bytes are still subject to J1850 message length maximums (see [28.5.2 J1850 Frame Format](#)). See [Figure 28-18](#)

- 1 = If this bit is set prior to a valid EOD being received with no CRC error, once the EOD symbol has been received, the BDLC will attempt to transmit the appropriate normalization bit followed by IFR bytes. The programmer should set TEOD after the last IFR byte has been written into the BDR. After TEOD has been set and the last IFR byte has been transmitted, the CRC byte is transmitted.
- 0 = The TMIFR1 bit will be cleared automatically, once the BDLC has successfully transmitted the CRC byte and EOD symbol, by the detection of an error on the multiplex bus or by a transmitter underrun caused when the programmer does not write another byte to the BDR after the TDRE interrupt.

If the TMIFR1 bit is set, the BDLC will attempt to transmit the normalization symbol followed by the byte in the BDR. After the byte in the BDR has been loaded into the transmit shift register, a TDRE interrupt (see [28.7.4 BDLC State Vector Register](#)) will occur similar to the main message transmit sequence. The programmer should then load the next byte of the IFR into the BDR for transmission. When the last byte of the IFR has been loaded into the BDR, the programmer should set the TEOD bit in the BDLC control register 2 (BCR2). This will instruct the BDLC to transmit a CRC byte once the byte in the BDR is transmitted, and then transmit an EOD symbol, indicating the end of the IFR portion of the message frame.

However, if the programmer wishes to transmit a single byte followed by a CRC byte, the programmer should load the byte into the BDR before the EOD symbol has been received, and then set the TMIFR1 bit. Once the TDRE interrupt occurs, the programmer should then set the TEOD bit in the BCR2. This will result in the byte in the BDR being the only byte transmitted before the IFR CRC byte, and no TDRE interrupt will be generated.

If the programmer attempts to set the TMIFR1 bit immediately after the EOD symbol has been received from the bus, the TMIFR1 bit will remain in the reset state, and no attempt will be made to transmit an IFR byte.

If a loss of arbitration occurs when the BDLC is transmitting any byte of a multiple byte IFR, the BDLC will go to the loss of arbitration state, set the appropriate flag, and cease transmission.

If the BDLC loses arbitration during the IFR, the TMIFR1 bit will be cleared and **no attempt** will be made to retransmit the byte in the BDR. If loss of arbitration occurs in the last two bits of the IFR byte, two additional 1 bits will be sent out.

**NOTE:** *The extra logic 1s are an enhancement to the J1850 protocol which forces a byte boundary condition fault. This is helpful in preventing noise on the J1850 bus from corrupting a message.*

#### TMIFR0 — Transmit Multiple Byte IFR without CRC (Type 3) Bit

The TMIFR0 bit is used to request the BDLC to transmit the byte in the BDLC data register (BDR) as the first byte of a multiple byte IFR without CRC. Response IFR bytes are still subject to J1850 message length maximums (see [28.5.2 J1850 Frame Format](#)). See [Figure 28-18](#).

1 = If this bit is set prior to a valid EOD being received with no CRC error, once the EOD symbol has been received, the BDLC will attempt to transmit the appropriate normalization bit followed by IFR bytes. The programmer should set TEOD after the last IFR byte has been written into the BDR. After TEOD has been set, the last IFR byte to be transmitted will be the last byte which was written into the BDR.



0 = The TMIFR0 bit will be cleared automatically, once the BDLC has successfully transmitted the EOD symbol, by the detection of an error on the multiplex bus or by a transmitter underrun caused when the programmer does not write another byte to the BDR after the TDRE interrupt.

If the TMIFR0 bit is set, the BDLC will attempt to transmit the normalization symbol followed by the byte in the BDR. After the byte in the BDR has been loaded into the transmit shift register, a TDRE interrupt (see [28.7.4 BDLC State Vector Register](#)) will occur similar to the main message transmit sequence. The programmer should then load the next byte of the IFR into the BDR for transmission. When the last byte of the IFR has been loaded into the BDR, the programmer should set the TEOD bit in the BCR2. This will instruct the BDLC to transmit an EOD symbol once the byte in the BDR is transmitted, indicating the end of the IFR portion of the message frame. The BDLC will not append a CRC when the TMIFR0 is set.

If the programmer attempts to set the TMIFR0 bit after the EOD symbol has been received from the bus, the TMIFR0 bit will remain in the reset state, and no attempt will be made to transmit an IFR byte.

If a loss of arbitration occurs when the BDLC is transmitting, the TMIFR0 bit will be cleared, and **no attempt** will be made to retransmit the byte in the BDR. If loss of arbitration occurs in the last two bits of the IFR byte, two additional 1 bits (active short bits) will be sent out.

**NOTE:** *The extra logic 1s are an enhancement to the J1850 protocol which forces a byte boundary condition fault. This is helpful in preventing noise on to the J1850 bus from a corrupted message.*


#### 28.7.4 BDLC State Vector Register

This register is provided to substantially decrease the CPU overhead associated with servicing interrupts while under operation of a multiplex protocol. It provides an index offset that is directly related to the BDLC's current state, which can be used with a user-supplied jump table to

rapidly enter an interrupt service routine. This eliminates the need for the user to maintain a duplicate state machine in software.

Address: \$003E

	Bit 7	6	5	4	3	2	1	Bit 0
Read:	0	0	I3	I2	I1	I0	0	0
Write:								
Reset:	0	0	0	0	0	0	0	0

 = Unimplemented

**Figure 28-19. BDLC State Vector Register (BSVR)**

### I0, I1, I2, and I3 — Interrupt Source Bits

These bits indicate the source of the interrupt request that currently is pending. The encoding of these bits are listed in [Table 28-6](#).

**Table 28-6. BDLC Interrupt Sources**

BSVR	I3	I2	I1	I0	Interrupt Source	Priority
\$00	0	0	0	0	No Interrupts Pending	0 (Lowest)
\$04	0	0	0	1	Received EOF	1
\$08	0	0	1	0	Received IFR Byte (RXIFR)	2
\$0C	0	0	1	1	BDLC Rx Data Register Full (RDRF)	3
\$10	0	1	0	0	BDLC Tx Data Register Empty (TDRE)	4
\$14	0	1	0	1	Loss of Arbitration	5
\$18	0	1	1	0	Cyclical Redundancy Check (CRC) Error	6
\$1C	0	1	1	1	Symbol Invalid or Out of Range	7
\$20	1	0	0	0	Wakeup	8 (Highest)

Bits I0, I1, I2, and I3 are cleared by a read of the BSVR except when the BDLC data register needs servicing (RDRF, RXIFR, or TDRE conditions). RXIFR and RDRF can be cleared only by a read of the BSVR followed by a read of the BDLC data register (BDR). TDRE can either be cleared by a read of the BSVR followed by a write to the BDLC BDR or by setting the TEOD bit in BCR2.

Upon receiving a BDLC interrupt, the user can read the value within the BSVR, transferring it to the CPU's index register. The value can then be used to index into a jump table, with entries four bytes apart, to quickly enter the appropriate service routine. For example:

```

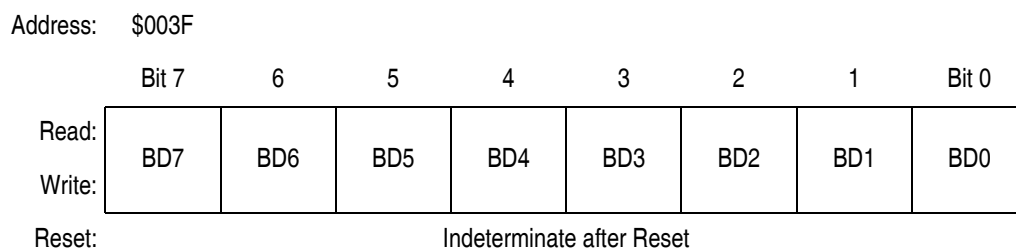
Service      LDX   BSVR      Fetch State Vector Number
              JMP   JMPTAB,X   Enter service routine,
*              (must end in RTI)
*
JMPTAB       JMP   SERVE0     Service condition #0
              NOP
              JMP   SERVE1     Service condition #1
              NOP
              JMP   SERVE2     Service condition #2
              NOP
*
              JMP   SERVE8     Service condition #8
              END
    
```

**NOTE:** *The NOPs are used only to align the JMPs onto 4-byte boundaries so that the value in the BSVR can be used intact. Each of the service routines must end with an RTI instruction to guarantee correct continued operation of the device. Note also that the first entry can be omitted since it corresponds to no interrupt occurring.*

The service routines should clear all of the sources that are causing the pending interrupts. Note that the clearing of a high priority interrupt may still leave a lower priority interrupt pending, in which case bits I0, I1, and I2 of the BSVR will then reflect the source of the remaining interrupt request.

If fewer states are used or if a different software approach is taken, the jump table can be made smaller or omitted altogether.

## 28.7.5 BDLC Data Register



**Figure 28-20. BDLC Data Register (BDR)**

This register is used to pass the data to be transmitted to the J1850 bus from the CPU to the BDLC. It is also used to pass data received from the J1850 bus to the CPU. Each data byte (after the first one) should be written only after a Tx data register empty (TDRE) state is indicated in the BSVR.

Data read from this register will be the last data byte received from the J1850 bus. This received data should only be read after an Rx data register full (RDRF) interrupt has occurred. (See [28.7.4 BDLC State Vector Register](#).)

The BDR is double buffered via a transmit shadow register and a receive shadow register. After the byte in the transmit shift register has been transmitted, the byte currently stored in the transmit shadow register is loaded into the transmit shift register. Once the transmit shift register has shifted the first bit out, the TDRE flag is set, and the shadow register is ready to accept the next data byte. The receive shadow register works similarly. Once a complete byte has been received, the receive shift register stores the newly received byte into the receive shadow register. The RDRF flag is set to indicate that a new byte of data has been received. The programmer has one BDLC byte reception time to read the shadow register and clear the RDRF flag before the shadow register is overwritten by the newly received byte.

To abort an in-progress transmission, the programmer should stop loading data into the BDR. This will cause a transmitter underrun error and the BDLC automatically will disable the transmitter on the next non-byte boundary. This means that the earliest a transmission can be halted

is after at least one byte plus two extra logic 1s have been transmitted. The receiver will pick this up as an error and relay it in the state vector register as an invalid symbol error.

**NOTE:** *The extra logic 1s are an enhancement to the J1850 protocol which forces a byte boundary condition fault. This is helpful in preventing noise on the J1850 bus from corrupting a message.*

## 28.8 Low-Power Modes

The following information concerns wait mode and stop mode.

### 28.8.1 Wait Mode

This power-conserving mode is entered automatically from run mode whenever the CPU executes a WAIT instruction and the WCM bit in BDLC control register 1 (BCR1) is previously clear. In BDLC wait mode, the BDLC cannot drive any data.

A subsequent successfully received message, including one that is in progress at the time that this mode is entered, will cause the BDLC to wake up and generate a CPU interrupt request if the interrupt enable (IE) bit in the BDLC control register 1 (BCR1) is previously set (see [28.7.2 BDLC Control Register 1](#) for a better understanding of IE). This results in less of a power saving, but the BDLC is guaranteed to receive correctly the message which woke it up, since the BDLC internal operating clocks are kept running.

**NOTE:** *Ensuring that all transmissions are complete or aborted before putting the BDLC into wait mode is important.*

### 28.8.2 Stop Mode

This power-conserving mode is entered automatically from run mode whenever the CPU executes a STOP instruction or if the CPU executes a WAIT instruction and the WCM bit in the BDLC control register 1 (BCR1) is previously set. This is the lowest power mode that the BDLC can enter.

A subsequent passive-to-active transition on the J1850 bus will cause the BDLC to wake up and generate a non-maskable CPU interrupt request. When a STOP instruction is used to put the BDLC in stop mode, the BDLC is not guaranteed to correctly receive the message which woke it up, since it may take some time for the BDLC internal operating clocks to restart and stabilize. If a WAIT instruction is used to put the BDLC in stop mode, the BDLC is guaranteed to correctly receive the byte which woke it up, if and only if an end-of-frame (EOF) has been detected prior to issuing the WAIT instruction by the CPU. Otherwise, the BDLC will not correctly receive the byte that woke it up.

If this mode is entered while the BDLC is receiving a message, the first subsequent received edge will cause the BDLC to wake up immediately, generate a CPU interrupt request, and wait for the BDLC internal operating clocks to restart and stabilize before normal communications can resume. Therefore, the BDLC is not guaranteed to receive that message correctly.

**NOTE:** *It is important to ensure all transmissions are complete or aborted prior to putting the BDLC into stop mode.*

## Section 29. Electrical Specifications

### 29.1 Contents

29.2	Maximum Ratings . . . . .	566
29.3	Functional Operating Range . . . . .	567
29.4	Thermal Characteristics . . . . .	567
29.5	5.0 Volt DC Electrical Characteristics . . . . .	568
29.6	Control Timing . . . . .	569
29.7	ADC Characteristics . . . . .	570
29.8	5.0 Vdc $\pm$ 10% Serial Peripheral Interface (SPI) Timing . . . . .	571
29.9	CGM Operating Conditions . . . . .	574
29.10	CGM Component Information . . . . .	574
29.11	CGM Acquisition/Lock Time Information . . . . .	575
29.12	Timer Module Characteristics . . . . .	576
29.13	Memory Characteristics . . . . .	576
29.14	BDLC Transmitter VPW Symbol Timings . . . . .	577
29.15	BDLC Receiver VPW Symbol Timings . . . . .	577

## 29.2 Maximum Ratings

Maximum ratings are the extreme limits to which the MCU can be exposed without permanently damaging it.

**NOTE:** *This device is not guaranteed to operate properly at the maximum ratings. Refer to [29.5 5.0 Volt DC Electrical Characteristics](#) for guaranteed operating conditions.*

Rating	Symbol	Value	Unit
Supply Voltage	$V_{DD}$	-0.3 to +6.0	V
Input Voltage	$V_{IN}$	$V_{SS} - 0.3$ to $V_{DD} + 0.3$	V
Maximum Current Per Pin Excluding $V_{DD}$ and $V_{SS}$	I	$\pm 25$	mA
Storage Temperature	$T_{STG}$	-55 to +150	°C
Maximum Current out of $V_{SS}$	$I_{MVSS}$	100	mA
Maximum Current into $V_{DD}$	$I_{MVDD}$	100	mA
Reset $\overline{IRQ}$ Input Voltage	$V_{HI}$	$V_{DD}$ to $V_{DD} + 2$	V

NOTE: Voltages are referenced to  $V_{SS}$ .

**NOTE:** *This device contains circuitry to protect the inputs against damage due to high static voltages or electric fields; however, it is advised that normal precautions be taken to avoid application of any voltage higher than maximum-rated voltages to this high-impedance circuit. For proper operation, it is recommended that  $V_{IN}$  and  $V_{OUT}$  be constrained to the range  $V_{SS} \leq (V_{IN} \text{ or } V_{OUT}) \leq V_{DD}$ . Reliability of operation is enhanced if unused inputs are connected to an appropriate logic voltage level (for example, either  $V_{SS}$  or  $V_{DD}$ ).*



### 29.3 Functional Operating Range

Rating	Symbol	Value	Unit
Operating Temperature Range	$T_A$	-40 to 125	°C
Operating Voltage Range	$V_{DD}$	$5.0 \pm 10\%$	V

### 29.4 Thermal Characteristics

Characteristic	Symbol	Value	Unit
Thermal Resistance QFP (64 Pins)	$\theta_{JA}$	70	°C/W
Thermal Resistance PLCC (52 Pins)	$\theta_{JA}$	50	°C/W
I/O Pin Power Dissipation	$P_{I/O}$	User Determined	W
Power Dissipation (see Note 1)	$P_D$	$P_D = (I_{DD} \times V_{DD}) +$ $P_{I/O} = K/(T_J + 273 \text{ °C})$	W
Constant (see Note 2)	K	$P_D \times (T_A + 273 \text{ °C})$ $+ (P_D^2 \times \theta_{JA})$	W/°C
Average Junction Temperature	$T_J$	$T_A = P_D \times \theta_{JA}$	°C
Maximum Junction Temperature	$T_{JM}$	125	°C

NOTES:

1. Power dissipation is a function of temperature.
2. K is a constant unique to the device. K can be determined from a known  $T_A$  and measured  $P_D$ . With this value of K,  $P_D$  and  $T_J$  can be determined for any value of  $T_A$ .

## 29.5 5.0 Volt DC Electrical Characteristics

Characteristic	Symbol	Min	Typ	Max	Unit
Output High Voltage ( $I_{Load} = -2.0$ mA) All Ports	$V_{OH}$	$V_{DD} - 0.8$	—	—	V
Output Low Voltage ( $I_{Load} = 1.6$ mA) All Ports	$V_{OL}$	—	—	0.4	V
Input High Voltage All Ports, $\overline{IRQS}$ , RESET, OSC1	$V_{IH}$	$0.7 \times V_{DD}$	—	$V_{DD}$	V
Input Low Voltage All Ports, $\overline{IRQS}$ , RESET, OSC1	$V_{IL}$	$V_{SS}$	—	$0.3 \times V_{DD}$	V
$V_{DD} + V_{DDA}$ Supply Current Run (see Note 3) Wait (see Note 4) Stop (see Note 5) 25 °C -40 °C to +125 °C 25 °C with LVI Enabled -40 °C to +125 °C with LVI Enabled	$I_{DD}$	— — — — — —	— — — — — —	30 15 5 50 400 500	mA mA $\mu$ A $\mu$ A $\mu$ A $\mu$ A
I/O Ports Hi-Z Leakage Current	$I_L$	—	—	$\pm 1$	$\mu$ A
Input Current	$I_{IN}$	—	—	$\pm 1$	$\mu$ A
Capacitance Ports (As Input or Output)	$C_{OUT}$ $C_{IN}$	— —	— —	12 8	pF
Low-Voltage Reset Inhibit	$V_{LVII}$	—	4.2	—	V
Low-Voltage Reset Inhibit/Recover Hysteresis	$H_{LVI}$	—	200	—	mV
POR ReArm Voltage (see Note 6)	$V_{POR}$	0	—	200	mV
POR Reset Voltage (see Note 7)	$V_{PORRST}$	0	—	800	mV
POR Rise Time Ramp Rate (see Note 8)	$R_{POR}$	0.02	—	—	V/ms
High COP Disable Voltage (see Note 9)	$V_{HI}$	$V_{DD}$		$V_{DD} + 2$	V

### NOTES:

- $V_{DD} = 5.0$  Vdc  $\pm 10\%$ ,  $V_{SS} = 0$  Vdc,  $T_A = -40$  °C to +125 °C, unless otherwise noted.
- Typical values reflect average measurements at midpoint of voltage range, 25 °C only.
- Run (Operating)  $I_{DD}$  measured using external square wave clock source ( $f_{OP} = 8.4$  MHz). All inputs 0.2 V from rail. No dc loads. Less than 100 pF on all outputs.  $C_L = 20$  pF on OSC2. All ports configured as inputs. OSC2 capacitance linearly affects run  $I_{DD}$ . Measured with all modules enabled.
- Wait  $I_{DD}$  measured using external square wave clock source ( $f_{OP} = 8.4$  MHz). All inputs 0.2 Vdc from rail. No dc loads. Less than 100 pF on all outputs.  $C_L = 20$  pF on OSC2. All ports configured as inputs. OSC2 capacitance linearly affects wait  $I_{DD}$ . Measured with all modules enabled.
- Stop  $I_{DD}$  measured with OSC1 =  $V_{SS}$ .
- Maximum is highest voltage that POR is guaranteed.
- Maximum is highest voltage that POR is possible.
- If minimum  $V_{DD}$  is not reached before the internal POR reset is released, RST must be driven low externally until minimum  $V_{DD}$  is reached.
- See [13.9 COP Module During Break Interrupts](#).

## 29.6 Control Timing

Characteristic	Symbol	Min	Max	Unit
Bus Operating Frequency (4.5–5.5 V — $V_{DD}$ Only)	$f_{BUS}$	—	8.4 M	Hz
$\overline{RESET}$ Pulse Width Low	$t_{RL}$	1.5	—	$t_{cyc}$
$\overline{IRQ}$ Interrupt Pulse Width Low (Edge-Triggered)	$t_{ILHI}$	1.5	—	$t_{cyc}$
$\overline{IRQ}$ Interrupt Pulse Period	$t_{ILIL}$	Note 3	—	$t_{cyc}$
EEPROM Programming Time per Byte	$t_{EEPGM}$	10	—	ms
EEPROM Erasing Time per Byte	$t_{EByte}$	10	—	ms
EEPROM Erasing Time per Block	$t_{EBLOCK}$	10	—	ms
EEPROM Erasing Time per Bulk	$t_{EBULK}$	10	—	ms
EEPROM Programming Voltage Discharge Period	$t_{EEFPV}$	100	—	$\mu s$
16-Bit Timer (see Note 2) Input Capture Pulse Width (see Note 3) Input Capture Period	$t_{TH}, t_{TL}$ $t_{TLTL}$	2 Note 4	— —	$t_{cyc}$

### NOTES:

1.  $V_{DD} = 5.0 \text{ Vdc} \pm 10\%$ ,  $V_{SS} = 0 \text{ Vdc}$ ,  $T_A = -40 \text{ }^\circ\text{C}$  to  $+105 \text{ }^\circ\text{C}$ , unless otherwise noted.
2. The 2-bit timer prescaler is the limiting factor in determining timer resolution.
3. Refer to [Table 18-3. Mode, Edge, and Level Selection](#) and supporting note.
4. The minimum period  $t_{TLTL}$  or  $t_{ILIL}$  should not be less than the number of cycles it takes to execute the capture interrupt service routine plus TBD  $t_{cyc}$ .

## 29.7 ADC Characteristics

Characteristic	Min	Max	Unit	Comments
Resolution	8	8	Bits	
Absolute Accuracy ( $V_{REFL} = 0\text{ V}$ , $V_{DDA} = V_{REFH} = 5\text{ V} \pm 10\%$ )	-1	+1	LSB	Includes Quantization
Conversion Range (see Note 1)	$V_{REFL}$	$V_{REFH}$	V	$V_{REFL} = V_{SSA}$
Power-Up Time	16	17	$\mu\text{s}$	Conversion Time Period
Input Leakage (see Note 3) Ports B and D	—	$\pm 1$	$\mu\text{A}$	
Conversion Time	16	17	ADC Clock Cycles	Includes Sampling Time
Monotonicity	Inherent within Total Error			
Zero Input Reading	00	01	Hex	$V_{IN} = V_{REFL}$
Full-Scale Reading	FE	FF	Hex	$V_{IN} = V_{REFH}$
Sample Time (see Note 2)	5	—	ADC Clock Cycles	
Input Capacitance	—	8	pF	Not Tested
ADC Internal Clock	500 k	1.048 M	Hz	Tested Only at 1 MHz
Analog Input Voltage	$V_{REFL}$	$V_{REFH}$	V	

**NOTES:**

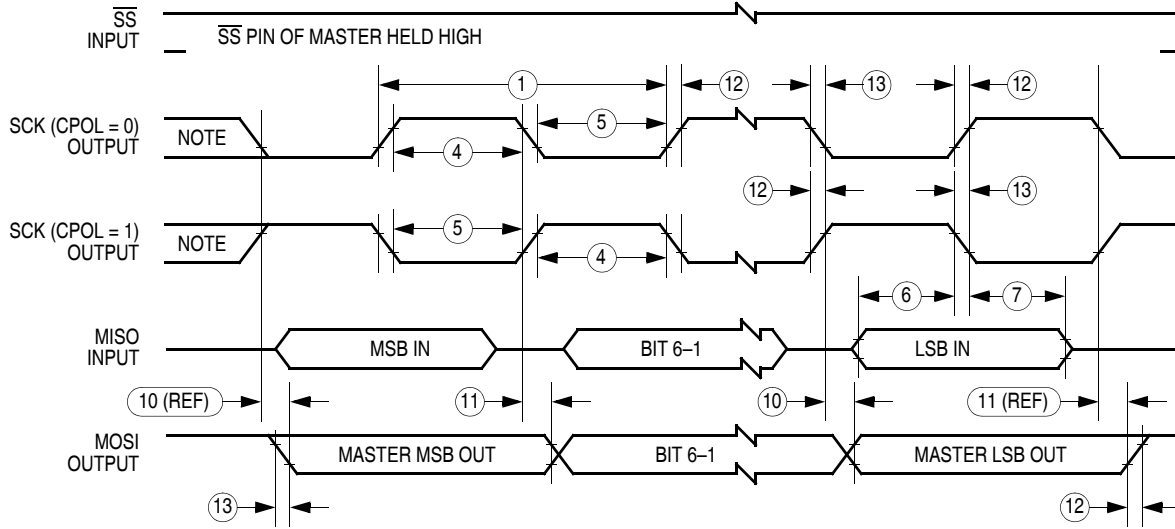
- $V_{DD} = 5.0\text{ Vdc} \pm 10\%$ ,  $V_{SS} = 0\text{ Vdc}$ ,  $V_{DDA}/V_{DDAREF} = 5.0\text{ Vdc} \pm 10\%$ ,  $V_{SSA} = 0\text{ Vdc}$ ,  $V_{REFH} = 5.0\text{ Vdc} \pm 10\%$
- Source impedances greater than  $10\text{ k}\Omega$  adversely affect internal RC charging time during input sampling.
- The external system error caused by input leakage current is approximately equal to the product of R source and input current.

## 29.8 5.0 Vdc ± 10% Serial Peripheral Interface (SPI) Timing

Num	Characteristic	Symbol	Min	Max	Unit
	Operating Frequency (see Note 3) Master Slave	$f_{BUS(M)}$ $f_{BUS(S)}$	$f_{BUS}/128$ dc	$f_{BUS}/2$ $f_{BUS}$	MHz
1	Cycle Time Master Slave	$t_{cyc(M)}$ $t_{cyc(S)}$	2 1	128 —	$t_{cyc}$
2	Enable Lead Time	$t_{Lead}$	15	—	ns
3	Enable Lag Time	$t_{Lag}$	15	—	ns
4	Clock (SCK) High Time Master Slave	$t_{W(SCKH)M}$ $t_{W(SCKH)S}$	100 50	— —	ns
5	Clock (SCK) Low Time Master Slave	$t_{W(SCKL)M}$ $t_{W(SCKL)S}$	100 50	— —	ns
6	Data Setup Time (Inputs) Master Slave	$t_{SU(M)}$ $t_{SU(S)}$	45 5	— —	ns
7	Data Hold Time (Inputs) Master Slave	$t_{H(M)}$ $t_{H(S)}$	0 15	— —	ns
8	Access Time, Slave (see Note 4) CPHA = 0 CPHA = 1	$t_{A(CP0)}$ $t_{A(CP1)}$	0 0	40 20	ns
9	Slave Disable Time (Hold Time to High-Impedance State) (see Note 5)	$t_{DIS}$	—	25	ns
10	Data Valid Time after Enable Edge (see Note 6) Master Slave	$t_{V(M)}$ $t_{V(S)}$	— —	10 40	ns
11	Data Hold Time (Outputs, after Enable Edge) Master Slave	$t_{HO(M)}$ $t_{HO(S)}$	0 5	— —	ns

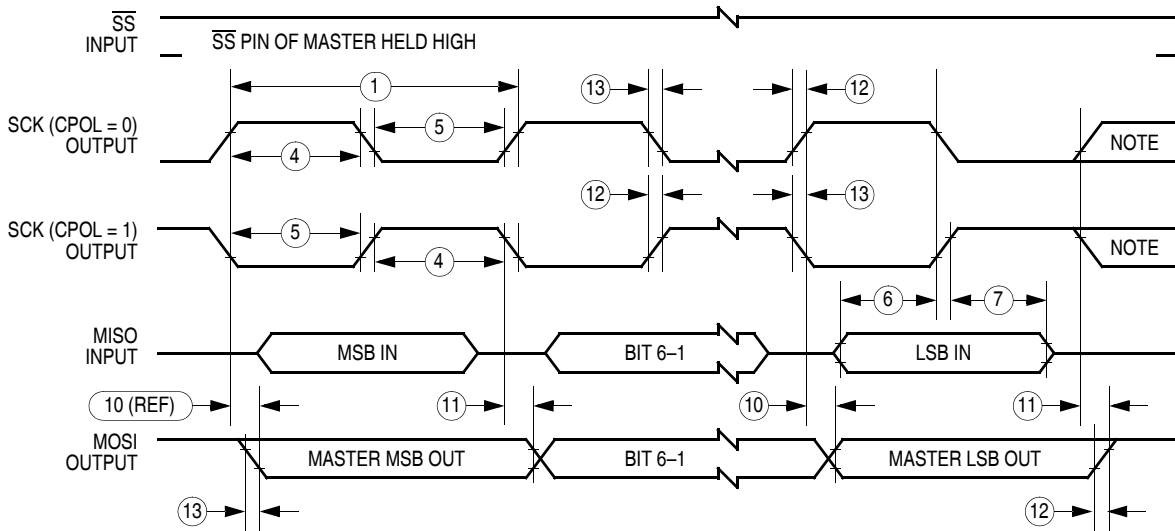
**NOTES:**

- All timing is shown with respect to 30%  $V_{DD}$  and 70%  $V_{DD}$ , unless otherwise noted; assumes 100 pF load on all SPI pins.
- Item numbers refer to dimensions in [Figure 29-1](#) and [Figure 29-2](#).
- $f_{BUS}$  = the currently active bus frequency for the microcontroller.
- Time to data active from high-impedance state.
- Hold time to high-impedance state.
- With 100 pF on all SPI pins



NOTE: This first clock edge is generated internally, but is not seen at the SCK pin.

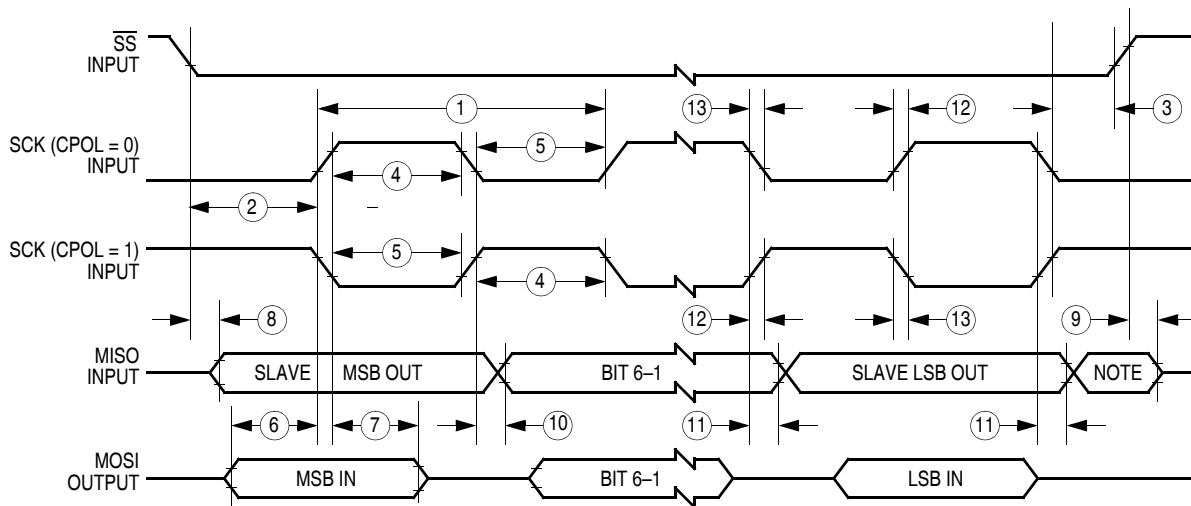
### a) SPI Master Timing (CPHA = 0)



NOTE: This last clock edge is generated internally, but is not seen at the SCK pin.

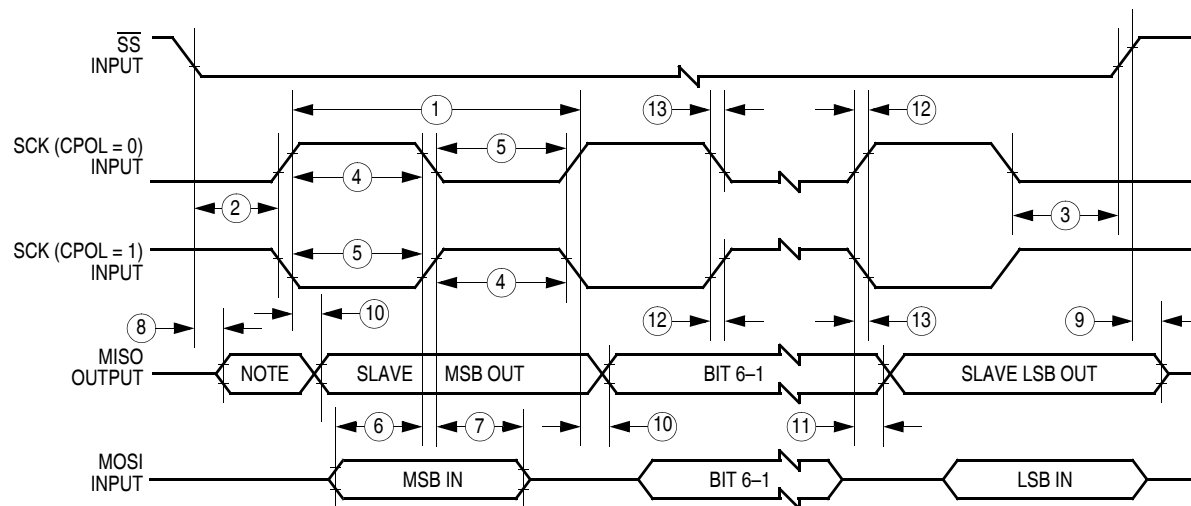
### b) SPI Master Timing (CPHA = 1)

**Figure 29-1. SPI Master Timing Diagram**



NOTE: Not defined but normally MSB of character just received.

### a) SPI Slave Timing (CPHA = 0)



NOTE: Not defined but normally LSB of character previously transmitted.

### a) SPI Slave Timing (CPHA = 1)

**Figure 29-2. SPI Slave Timing Diagram**

## 29.9 CGM Operating Conditions

Characteristic	Symbol	Min	Typ	Max	Comments
Operating Voltage	$V_{DD}$	4.5 V	—	5.5 V	
Crystal Reference Frequency	$f_{RCLK}$	1	—	8.4	
Module Crystal Reference Frequency	$f_{XCLK}$	—	4.9152 MHz	—	Same Frequency as $f_{RCLK}$
Range Nom. Multiplier (MHz)	$f_{NOM}$	—	4.9152	—	4.5–5.5 V, $V_{DD}$ only
VCO Center-of-Range Frequency (MHz)	$f_{VRS}$	4.9152	—	32.0	4.5–5.5 V, $V_{DD}$ only
VCO Operating Frequency (MHz)	$f_{VCLK}$	4.9152	—	32.0	

## 29.10 CGM Component Information

Description	Symbol	Min	Typ	Max	Comments
Crystal Load Capacitance	$C_L$	—	—	—	Consult Crystal Manufacturer's Data
Crystal Fixed Capacitance	$C_1$	—	2 x $C_L$	—	Consult Crystal Manufacturer's Data
Crystal Tuning Capacitance	$C_2$	—	2 x $C_L$	—	Consult Crystal Manufacturer's Data
Filter Capacitor Multiply Factor	$C_{Fact}$	—	0.0154	—	F/s V
Filter Capacitor	$C_F$	—	$C_{Fact} \times (V_{DDA} / f_{XCLK})$	—	See <a href="#">8.5.3 External Filter Capacitor Pin (CGMXFC)</a>
Bypass Capacitor	CBYP	—	0.1 $\mu$ F	—	CBYP must provide low AC impedance from $f = f_{XCLK}/100$ to $100 \times f_{VCLK}$ , so series resistance must be considered.



## 29.11 CGM Acquisition/Lock Time Information

Description	Symbol	Min	Typ	Max	Notes
Manual Mode Time to Stable	$t_{ACQ}$	—	$(8 \times V_{DDA}) / (f_{XCLK} \times K_{ACQ})$	—	If $C_F$ Chosen Correctly
Manual Stable to Lock Time	$t_{AL}$	—	$(4 \times V_{DDA}) / (f_{XCLK} \times K_{TRK})$	—	If $C_F$ Chosen Correctly
Manual Acquisition Time	$t_{Lock}$	—	$t_{ACQ} + t_{AL}$	—	
Tracking Mode Entry Frequency Tolerance	$D_{TRK}$	0	—	$\pm 3.6\%$	
Acquisition Mode Entry Frequency Tolerance	$D_{UNT}$	$\pm 6.3\%$	—	$\pm 7.2\%$	
LOCK Entry Freq. Tolerance	$D_{LOCK}$	0	—	$\pm 0.9\%$	
LOCK Exit Freq. Tolerance	$D_{UNL}$	$\pm 0.9\%$	—	$\pm 1.8\%$	
Reference Cycles per Acquisition Mode Measurement	$n_{ACQ}$	—	32	—	
Reference Cycles per Tracking Mode Measurement	$n_{TRK}$	—	128	—	
Automatic Mode Time to Stable	$t_{ACQ}$	$n_{ACQ} / f_{XCLK}$	$(8 \times V_{DDA}) / (f_{XCLK} \times K_{ACQ})$	—	If $C_F$ Chosen Correctly
Automatic Stable to Lock Time	$t_{AL}$	$n_{TRK} / f_{XCLK}$	$(4 \times V_{DDA}) / (f_{XCLK} \times K_{TRK})$	—	If $C_F$ Chosen Correctly
Automatic Lock Time	$t_{Lock}$	—	$t_{ACQ} + t_{AL}$	—	
PLL Jitter, Deviation of Average Bus Frequency over 2 ms		0	—	$\pm (f_{CRYS}) \times (.025\%) \times (N/4)$	N = VCO Freq. Mult. (GBNT)

**NOTES:**

1. GBNT guaranteed but not tested
2.  $V_{DD} = 5.0 \text{ Vdc} \pm 10\%$ ,  $V_{SS} = 0 \text{ Vdc}$ ,  $T_A = -40 \text{ }^\circ\text{C}$  to  $+125 \text{ }^\circ\text{C}$ , unless otherwise noted.

## 29.12 Timer Module Characteristics

Characteristic	Symbol	Min	Max	Unit
Input Capture Pulse Width	$t_{TIH}, t_{TIL}$	125	—	ns
Input Clock Pulse Width	$t_{TCH}, t_{TCL}$	$(1/f_{OP}) + 5$	—	ns

## 29.13 Memory Characteristics

Characteristic	Symbol	Min	Max	Unit
RAM Data Retention Voltage	$V_{RDR}$	0.7	—	V
EEPROM Write/Erase Cycles @ 10 ms Write Time + 85 °C		10,000	—	Cycles
EEPROM Data Retention After 10,000 Write/Erase Cycles		10	—	Years
FLASH Bus Clock Period	$t_{cyc}$	250		ns
FLASH Erase Time	$t_{Erase}$	500		ms
FLASH High-Voltage Kill Time	$t_{Kill}$	200		$\mu$ s
FLASH Return to Read Time	$t_{HVD}$	50		$\mu$ s
FLASH Program Time, $t_{PROG}$	$t_{Prog}$	1	100	ms
FLASH HVEN Low to VERT High Time, $t_{HVTV}$	$t_{HVTV}$	50		$\mu$ s
FLASH VERIFY high to PGM Low Time, $t_{VTP}$	$t_{VTP}$	150		$\mu$ s
FLASH Endurance	Erase/Program cycles		1000	Cycles
FLASH Block Endurance	Erase/Program cycles for a block while maintaining data in the rest of the array		100	Cycles

## 29.14 BDLC Transmitter VPW Symbol Timings

Characteristic	Number	Symbol	Min	Typ	Max	Unit
Passive Logic 0	10	$t_{TVP1}$	62	64	66	$\mu\text{s}$
Passive Logic 1	11	$t_{TVP2}$	126	128	130	$\mu\text{s}$
Active Logic 0	12	$t_{TVA1}$	126	128	130	$\mu\text{s}$
Active Logic 1	13	$t_{TVA2}$	62	64	66	$\mu\text{s}$
Start of Frame (SOF)	14	$t_{TVA3}$	198	200	202	$\mu\text{s}$
End of Data (EOD)	15	$t_{TVP3}$	198	200	202	$\mu\text{s}$
End of Frame (EOF)	16	$t_{TV4}$	278	280	282	$\mu\text{s}$
Inter-Frame Separator (IFS)	17	$t_{TV6}$	298	300	302	$\mu\text{s}$

NOTES:

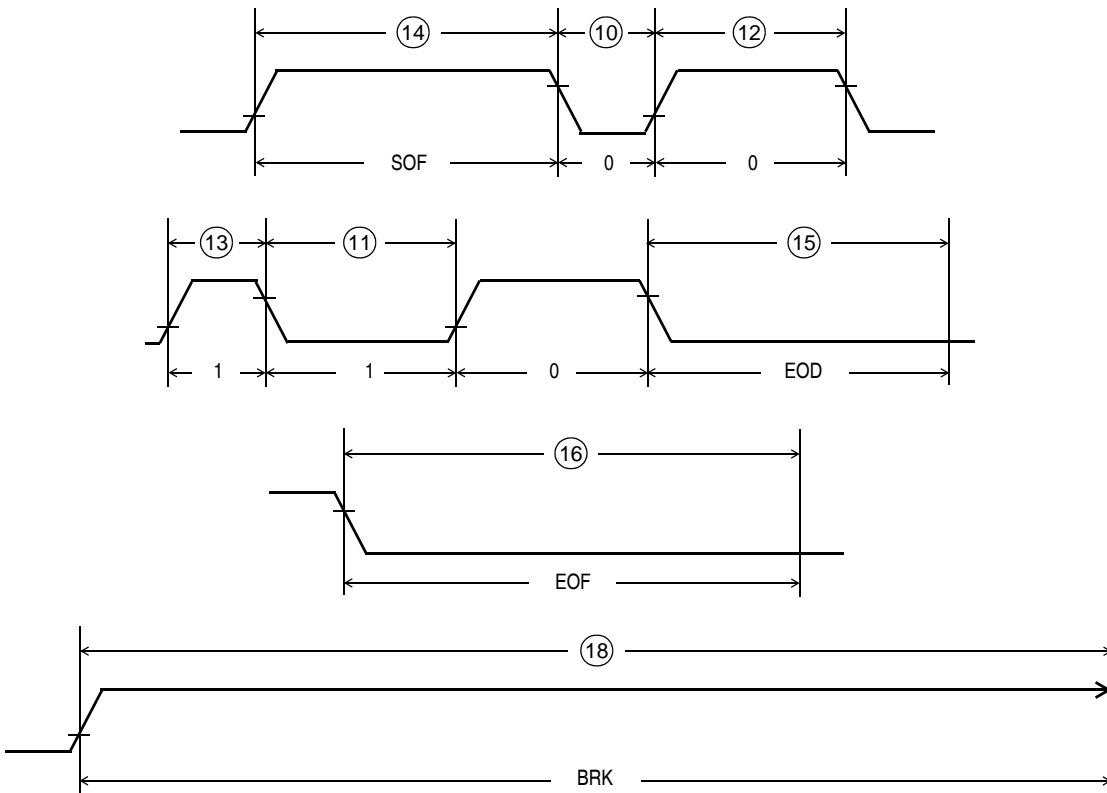
- $f_{\text{BDLC}} = 1.048576$  or  $1.0$  MHz,  $V_{\text{DD}} = 5.0 \text{ V} \pm 10\%$ ,  $V_{\text{SS}} = 0 \text{ V}$ .
- The receiver symbol timing boundaries are subject to an uncertainty of  $1 t_{\text{BDLC}} \mu\text{s}$  due to sampling considerations.

## 29.15 BDLC Receiver VPW Symbol Timings

Characteristic	Number	Symbol	Min	Typ	Max	Unit
Passive Logic 0	10	$t_{\text{TRVP1}}$	34	64	96	$\mu\text{s}$
Passive Logic 1	11	$t_{\text{TRVP2}}$	96	128	163	$\mu\text{s}$
Active Logic 0	12	$t_{\text{TRVA1}}$	96	128	163	$\mu\text{s}$
Active Logic 1	13	$t_{\text{TRVA2}}$	34	64	96	$\mu\text{s}$
Start of Frame (SOF)	14	$t_{\text{TRVA3}}$	163	200	239	$\mu\text{s}$
End of Data (EOD)	15	$t_{\text{TRVP3}}$	163	200	239	$\mu\text{s}$
End of Frame (EOF)	16	$t_{\text{TRV4}}$	239	280	320	$\mu\text{s}$
Break	18	$t_{\text{TRV6}}$	280	—	—	$\mu\text{s}$

NOTES:

- $f_{\text{BDLC}} = 1.048576$  or  $1.0$  MHz,  $V_{\text{DD}} = 5.0 \text{ V} \pm 10\%$ ,  $V_{\text{SS}} = 0 \text{ V}$ .
- The receiver symbol timing boundaries are subject to an uncertainty of  $1 t_{\text{BDLC}} \mu\text{s}$  due to sampling considerations.



**Figure 29-3. BDLC Variable Pulse Width Modulation (VPW) Symbol Timing**

## Section 30. Mechanical Data

### 30.1 Contents

30.2	Introduction . . . . .	579
30.3	52-Pin Plastic Leaded Chip Carrier Package (Case 778) . . . .	580
30.4	64-Pin Quad Flat Pack (QFP) . . . . .	581

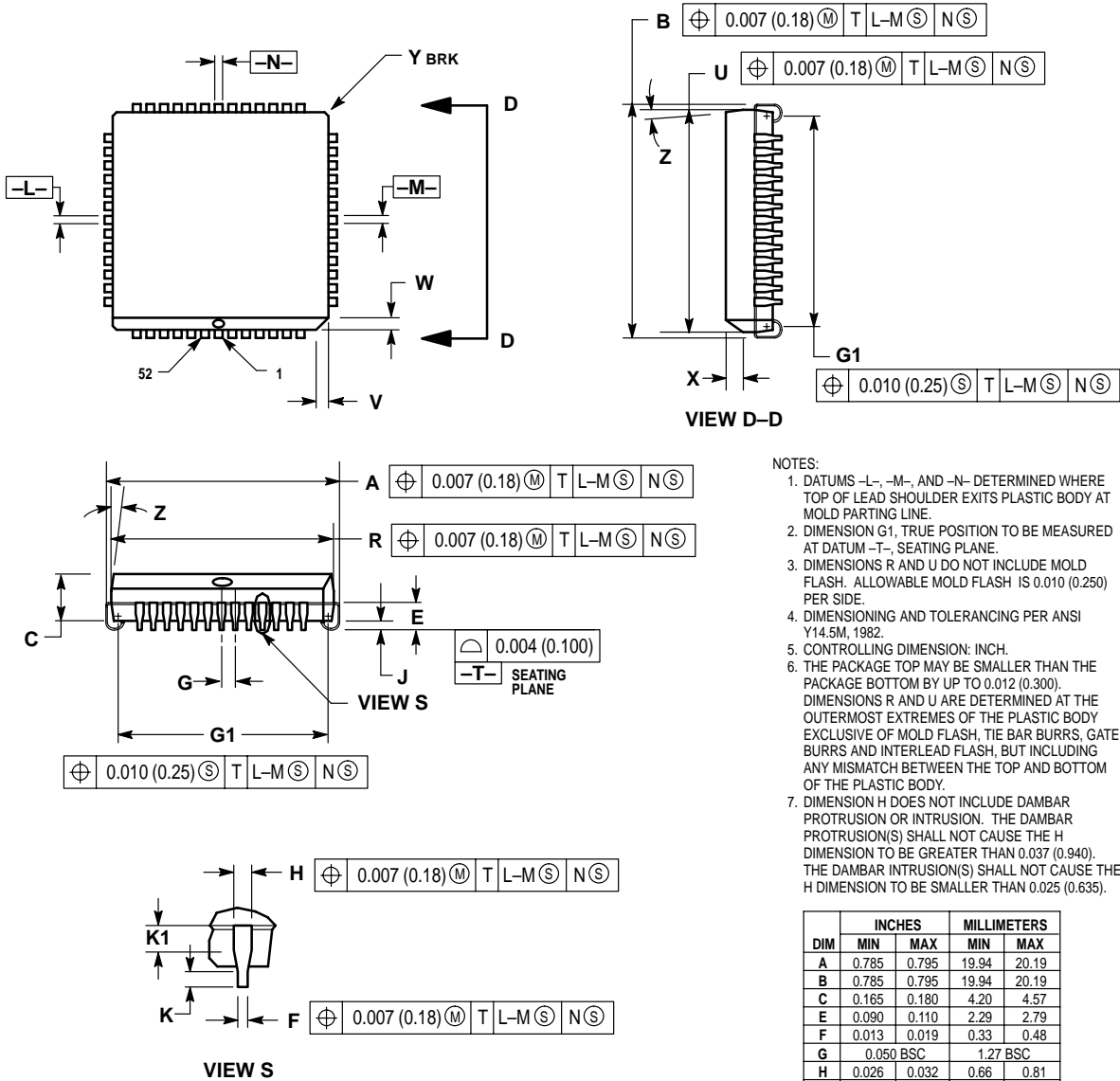
### 30.2 Introduction

This section provides package dimensions for:

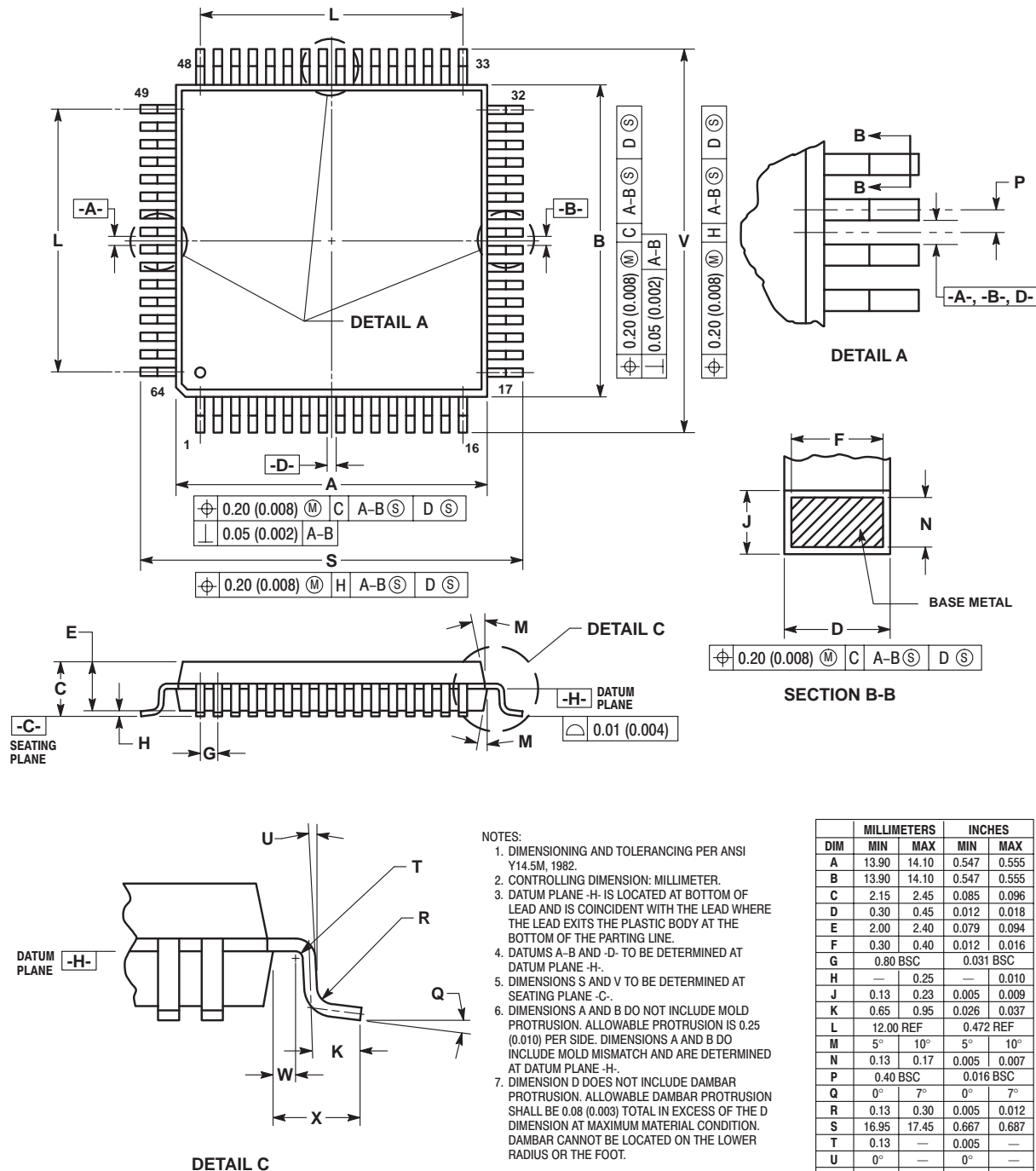
- MC68HC08AS20 emulator packaged in a 52-pin plastic leaded chip carrier (PLCC)
- MC68HC08AZ32 emulator packaged in a 64-pin quad flat pack (QFP)

The following figure shows the latest package at the time of this publication. To make sure that you have the latest package specifications, please visit the Freescale website at <http://freescale.com>. Follow the on-line instructions to retrieve the current mechanical specifications.

## 30.3 52-Pin Plastic Leaded Chip Carrier Package (Case 778)



### 30.4 64-Pin Quad Flat Pack (QFP)



DIM	MILLIMETERS		INCHES	
	MIN	MAX	MIN	MAX
A	13.90	14.10	0.547	0.555
B	13.90	14.10	0.547	0.555
C	2.15	2.45	0.085	0.096
D	0.30	0.45	0.012	0.018
E	2.00	2.40	0.079	0.094
F	0.30	0.40	0.012	0.016
G	0.80 BSC		0.031 BSC	
H	— 0.25		— 0.010	
J	0.13	0.23	0.005	0.009
K	0.65	0.95	0.026	0.037
L	12.00 REF		0.472 REF	
M	5°	10°	5°	10°
N	0.13	0.17	0.005	0.007
P	0.40 BSC		0.016 BSC	
Q	0° 7°		0° 7°	
R	0.13	0.30	0.005	0.012
T	0.13		— 0.005	
U	0°		— 0°	
V	16.95	17.45	0.667	0.687
W	0.35	0.45	0.014	0.018
X	1.6 REF		0.063 REF	



## Mechanical Data



## Section 31. Ordering Information

### 31.1 Contents

31.2	Introduction . . . . .	583
31.3	MC Order Numbers . . . . .	583

### 31.2 Introduction

This section contains instructions for ordering the MC68HC908AT32.

### 31.3 MC Order Numbers

**Table 31-1. MC Order Numbers**

MC Order Number	Operating Temperature Range
MC68HC908AT32FN <sup>(1)</sup> MC68HC908AT32CFN MC68HC908AT32VFN MC68HC908AT32MFN	0 °C to + 70 °C – 40 °C to + 85 °C – 40 °C to + 105 °C – 40 °C to + 125 °C
MC68HC908AT32FU <sup>(2)</sup> MC68HC908AT32CFU MC68HC908AT32VFU MC68HC908AT32MFU	0 °C to + 70 °C – 40 °C to + 85 °C – 40 °C to + 105 °C – 40 °C to + 125 °C

1. FN = plastic leaded chip carrier — MC68HC08AS20 emulator
2. FU = quad flat pack — MC68HC08AZ32 emulator



## Ordering Information



## How to Reach Us:

**Home Page:**  
[www.freescale.com](http://www.freescale.com)

**E-mail:**  
[support@freescale.com](mailto:support@freescale.com)

**USA/Europe or Locations Not Listed:**  
Freescale Semiconductor  
Technical Information Center, CH370  
1300 N. Alma School Road  
Chandler, Arizona 85224  
+1-800-521-6274 or +1-480-768-2130  
[support@freescale.com](mailto:support@freescale.com)

**Europe, Middle East, and Africa:**  
Freescale Halbleiter Deutschland GmbH  
Technical Information Center  
Schatzbogen 7  
81829 Muenchen, Germany  
+44 1296 380 456 (English)  
+46 8 52200080 (English)  
+49 89 92103 559 (German)  
+33 1 69 35 48 48 (French)  
[support@freescale.com](mailto:support@freescale.com)

**Japan:**  
Freescale Semiconductor Japan Ltd.  
Headquarters  
ARCO Tower 15F  
1-8-1, Shimo-Meguro, Meguro-ku,  
Tokyo 153-0064  
Japan  
0120 191014 or +81 3 5437 9125  
[support.japan@freescale.com](mailto:support.japan@freescale.com)

**Asia/Pacific:**  
Freescale Semiconductor Hong Kong Ltd.  
Technical Information Center  
2 Dai King Street  
Tai Po Industrial Estate  
Tai Po, N.T., Hong Kong  
+800 2666 8080  
[support.asia@freescale.com](mailto:support.asia@freescale.com)

**For Literature Requests Only:**  
Freescale Semiconductor Literature Distribution Center  
P.O. Box 5405  
Denver, Colorado 80217  
1-800-441-2447 or 303-675-2140  
Fax: 303-675-2150  
[LDCForFreescaleSemiconductor@hibbertgroup.com](mailto:LDCForFreescaleSemiconductor@hibbertgroup.com)

Rev. 2.1  
HC908AT32GRS/D  
July 29, 2005

RoHS-compliant and/or Pb- free versions of Freescale products have the functionality and electrical characteristics of their non-RoHS-compliant and/or non-Pb- free counterparts. For further information, see <http://www.freescale.com> or contact your Freescale sales representative.

For information on Freescale's Environmental Products program, go to <http://www.freescale.com/epp>.

Information in this document is provided solely to enable system and software implementers to use Freescale Semiconductor products. There are no express or implied copyright licenses granted hereunder to design or fabricate any integrated circuits or integrated circuits based on the information in this document.

Freescale Semiconductor reserves the right to make changes without further notice to any products herein. Freescale Semiconductor makes no warranty, representation or guarantee regarding the suitability of its products for any particular purpose, nor does Freescale Semiconductor assume any liability arising out of the application or use of any product or circuit, and specifically disclaims any and all liability, including without limitation consequential or incidental damages. "Typical" parameters that may be provided in Freescale Semiconductor data sheets and/or specifications can and do vary in different applications and actual performance may vary over time. All operating parameters, including "Typicals", must be validated for each customer application by customer's technical experts. Freescale Semiconductor does not convey any license under its patent rights nor the rights of others. Freescale Semiconductor products are not designed, intended, or authorized for use as components in systems intended for surgical implant into the body, or other applications intended to support or sustain life, or for any other application in which the failure of the Freescale Semiconductor product could create a situation where personal injury or death may occur. Should Buyer purchase or use Freescale Semiconductor products for any such unintended or unauthorized application, Buyer shall indemnify and hold Freescale Semiconductor and its officers, employees, subsidiaries, affiliates, and distributors harmless against all claims, costs, damages, and expenses, and reasonable attorney fees arising out of, directly or indirectly, any claim of personal injury or death associated with such unintended or unauthorized use, even if such claim alleges that Freescale Semiconductor was negligent regarding the design or manufacture of the part.

Freescale™ and the Freescale logo are trademarks of Freescale Semiconductor, Inc. All other product or service names are the property of their respective owners. The ARM POWERED logo is a registered trademark of ARM Limited. ARM7TDMI-S is a trademark of ARM Limited. Java and all other Java-based marks are trademarks or registered trademarks of Sun Microsystems, Inc. in the U.S. and other countries. The Bluetooth trademarks are owned by their proprietor and used by Freescale Semiconductor, Inc. under license.

© Freescale Semiconductor, Inc. 2005. All rights reserved.